

This report is one in a series of volumes published by the U.S. Environmental Protection Agency (EPA) to provide information of general interest regarding environmental issues associated with specific industrial sectors. The documents were developed under contract by Abt Associates (Cambridge, MA), and Booz-Allen & Hamilton, Inc. (McLean, VA). This publication may be **purchased** from the Superintendent of Documents, U.S. Government Printing Office. A listing of available Sector Notebooks and document numbers is included at the end of this document.

**All telephone orders should be directed to:**

Superintendent of Documents  
U.S. Government Printing Office  
Washington, DC 20402  
(202) 512-1800  
FAX (202) 512-2250  
9:00 a.m. to 4:30 p.m., ET, M-F

**Using the form provided at the end of this document, all mail orders should be directed to:**

U.S. Government Printing Office  
P.O. Box 371954  
Pittsburgh, PA 15250-7954

**Complimentary** volumes are available to certain groups or subscribers, such as public and academic libraries, Federal, State, local, and foreign governments, and the media. For further information and for answers to questions pertaining to these documents, please refer to the contact names and numbers provided within this volume.

**Electronic** versions of all Sector Notebooks are available free of charge at the following web address: **[www.epa.gov/oeca/sector](http://www.epa.gov/oeca/sector)**. Direct technical questions to the "Feedback" button at the bottom of the web page.

Cover photograph by Steve Delaney, EPA.

EPA/310-R-95-013

**EPA Office of Compliance Sector Notebook Project**  
**Profile of the Petroleum Refining Industry**

**September 1995**

Office of Compliance  
Office of Enforcement and Compliance Assurance  
U.S. Environmental Protection Agency  
401 M St., SW (MC 2221-A)  
Washington, DC 20460

## Sector Notebook Contacts

The Sector Notebooks were developed by the EPA's Office of Compliance. Questions relating to the Sector Notebook Project can be directed to:

Seth Heminway, Coordinator, Sector Notebook Project  
 US EPA Office of Compliance  
 401 M St., SW (2223-A)  
 Washington, DC 20460  
 (202) 564-7017

Questions and comments regarding the individual documents can be directed to the appropriate specialists listed below.

Document Number	Industry	Contact	Phone (202)
EPA/310-R-95-001.	Dry Cleaning Industry	Joyce Chandler	564-7073
EPA/310-R-95-002.	Electronics and Computer Industry*	Steve Hoover	564-7007
EPA/310-R-95-003.	Wood Furniture and Fixtures Industry	Bob Marshall	564-7021
EPA/310-R-95-004.	Inorganic Chemical Industry*	Walter DeRieux	564-7067
EPA/310-R-95-005.	Iron and Steel Industry	Maria Malave	564-7027
EPA/310-R-95-006.	Lumber and Wood Products Industry	Seth Heminway	564-7017
EPA/310-R-95-007.	Fabricated Metal Products Industry*	Scott Throwe	564-7013
EPA/310-R-95-008.	Metal Mining Industry	Jane Engert	564-5021
EPA/310-R-95-009.	Motor Vehicle Assembly Industry	Anthony Raia	564-6045
EPA/310-R-95-010.	Nonferrous Metals Industry	Jane Engert	564-5021
EPA/310-R-95-011.	Non-Fuel, Non-Metal Mining Industry	Rob Lischinsky	564-2628
EPA/310-R-95-012.	Organic Chemical Industry*	Walter DeRieux	564-7067
EPA/310-R-95-013.	Petroleum Refining Industry	Tom Ripp	564-7003
EPA/310-R-95-014.	Printing Industry	Ginger Gotliffe	564-7072
EPA/310-R-95-015.	Pulp and Paper Industry	Seth Heminway	564-7017
EPA/310-R-95-016.	Rubber and Plastic Industry	Maria Malave	564-7027
EPA/310-R-95-017.	Stone, Clay, Glass, and Concrete Industry	Scott Throwe	564-7013
EPA/310-R-95-018.	Transportation Equipment Cleaning Ind.	Virginia Lathrop	564-7057
EPA/310-R-97-001.	Air Transportation Industry	Virginia Lathrop	564-7057
EPA/310-R-97-002.	Ground Transportation Industry	Virginia Lathrop	564-7057
EPA/310-R-97-003.	Water Transportation Industry	Virginia Lathrop	564-7057
EPA/310-R-97-004.	Metal Casting Industry	Jane Engert	564-5021
EPA/310-R-97-005.	Pharmaceuticals Industry	Emily Chow	564-7071
EPA/310-R-97-006.	Plastic Resin and Man-made Fiber Ind.	Sally Sasnett	564-7074
EPA/310-R-97-007.	Fossil Fuel Electric Power Generation Ind.	Rafael Sanchez	564-7028
EPA/310-R-97-008.	Shipbuilding and Repair Industry	Anthony Raia	564-6045
EPA/310-R-97-009.	Textile Industry	Belinda Breidenbach	564-7022
EPA/310-R-97-010.	Sector Notebook Data Refresh-1997	Seth Heminway	564-7017
EPA/310-R-98-001.	Aerospace Industry	Anthony Raia	564-6045
EPA/310-R-98-002.	Agricultural Chemical, Pesticide, and Fertilizer Industry	Amy Porter	564-4149
EPA/310-R-98-003.	Agricultural Crop Production Industry	Ginah Mortensen	(913)551-7864
EPA/310-R-98-004.	Agricultural Livestock Production Ind.	Ginah Mortensen	(913)551-7864
EPA/310-R-98-005.	Oil and Gas Exploration and Production Industry	Dan Chadwick	564-7054
EPA/310-R-98-008.	Local Government Operations	John Dombrowski	564-7036

\*Spanish Translations Available

## Industry Sector Notebook Contents: Petroleum Refining

List of Exhibits .....	iii
List of Acronyms .....	iv
<b>I. INTRODUCTION TO THE SECTOR NOTEBOOK PROJECT .....</b>	<b>1</b>
A. Summary of the Sector Notebook Project .....	1
B. Additional Information .....	2
<b>II. INTRODUCTION TO THE PETROLEUM REFINING INDUSTRY .....</b>	<b>3</b>
A. Introduction, Background, and Scope of the Notebook .....	3
B. Characterization of the Petroleum Refining Industry .....	4
1. Product Characterization .....	4
2. Industry Size and Geographic Distribution .....	6
3. Economic Trends .....	10
<b>III. INDUSTRIAL PROCESS DESCRIPTION .....</b>	<b>13</b>
A. Industrial Processes in the Petroleum Refining Industry .....	13
1. Crude Oil Distillation and Desalting .....	15
2. Downstream Processing .....	18
3. Supporting Operations .....	30
B. Raw Material Inputs and Pollution Outputs in the Production Line .....	38
C. Management of Chemicals in Wastestream .....	42
<b>IV. CHEMICAL RELEASE AND TRANSFER PROFILE .....</b>	<b>45</b>
A. EPA Toxic Release Inventory for the Petroleum Refining Industry .....	48
B. Summary of Selected Chemicals Released .....	55
C. Other Data Sources .....	61
D. Comparison of Toxic Release Inventory Between Selected Industries .....	63
<b>V. POLLUTION PREVENTION OPPORTUNITIES .....</b>	<b>67</b>
<b>VI. SUMMARY OF APPLICABLE FEDERAL STATUTES AND REGULATIONS .....</b>	<b>77</b>
A. General Description of Major Statutes .....	77
B. Industry Specific Requirements .....	88
C. Pending and Proposed Regulatory Requirements .....	99

VII. COMPLIANCE AND ENFORCEMENT HISTORY ..... 103

- A. Petroleum Refining Compliance History ..... 107
- B. Comparison of Enforcement Activity Between Selected Industries ..... 109
- C. Review of Major Legal Actions ..... 114

VIII. COMPLIANCE ASSURANCE ACTIVITIES AND INITIATIVES ..... 117

- A. Sector-Related Environmental Programs and Activities ..... 117
- B. EPA Voluntary Programs ..... 118
- C. Trade Association/Industry Sponsored Activity ..... 122
  - 1. Environmental Programs ..... 122
  - 2. Summary of Trade Associations ..... 124

IX. CONTACTS/ACKNOWLEDGMENTS/RESOURCE MATERIALS/BIBLIOGRAPHY .. 127

END NOTES

### List of Exhibits

Exhibit 1: U.S. Refinery Products and Yields . . . . .	5
Exhibit 2: Large Facilities Dominate Petroleum Refining Industry . . . . .	7
Exhibit 3: Crude Oil Distillation Capacity Located Primarily Along Coasts . . . . .	8
Exhibit 4: U.S. Petroleum Refinery Distribution . . . . .	9
Exhibit 5: Top U.S. Companies with Petroleum Refining Operations . . . . .	10
Exhibit 6: Simplified Process Flow Diagram of Typical Refinery . . . . .	13
Exhibit 7: Crude Oil Distillation . . . . .	17
Exhibit 8: Simplified Thermal Cracker Flow Diagram . . . . .	18
Exhibit 9: Simplified Coker Flow Diagram . . . . .	20
Exhibit 10: Simplified Catalytic Cracking Flow Diagram . . . . .	22
Exhibit 11: Simplified Two-Stage Hydrocracker Flow Diagram . . . . .	24
Exhibit 12: Simplified Hydrotreater Flow Diagram . . . . .	26
Exhibit 13: Typical Refinery Wastewater Treatment System . . . . .	33
Exhibit 14: Simplified Claus Sulfur Recovery Flow Diagram . . . . .	34
Exhibit 15: Typical Material Outputs from Selected Petroleum Refining Processes . . . . .	40
Exhibit 16: Source Reduction and Recycling Activity for Petroleum Industry (SIC 2911) as Reported within TRI . . . . .	43
Exhibit 17: 1993 Releases for Petroleum Refining Facilities in TRI, by Number of Facilities Reporting . . . . .	50
Exhibit 18: 1993 Transfers for Petroleum Refining Facilities in TRI, by Number of Facilities Reporting . . . . .	52
Exhibit 19: Top 10 TRI Releasing Petroleum Refineries . . . . .	54
Exhibit 20: Top 10 TRI Releasing Facilities Reporting Petroleum Refining SIC Codes to TRI . . . . .	55
Exhibit 21: Pollutant Releases (short tons/year) . . . . .	61
Exhibit 22: Summary of 1993 TRI Releases and Transfers by Industry . . . . .	64
Exhibit 23: Toxics Release Inventory Data for Selected Industries . . . . .	65
Exhibit 24: Five-Year Enforcement and Compliance Summary for Petroleum Refining . . . . .	108
Exhibit 25: Five-Year Enforcement and Compliance Summary for Selected Industries . . . . .	110
Exhibit 26: One-Year Inspection and Enforcement Summary for Selected Industries . . . . .	111
Exhibit 27: Five-Year Inspection and Enforcement Summary by Statute for Selected Industries . . . . .	112
Exhibit 28: One-Year Inspection and Enforcement Summary by Statute for Selected Industries . . . . .	113
Exhibit 29: FY-1993,1994 Supplemental Environmental Projects Overview: Petroleum Refining . . . . .	116
Exhibit 30: 33/50 Program Participants Reporting SIC 2911 (Petroleum Refining) . . . . .	119

**List of Acronyms**

AFS -	AIRS Facility Subsystem (CAA database)
AIRS -	Aerometric Information Retrieval System (CAA database)
BIFs -	Boilers and Industrial Furnaces (RCRA)
BOD -	Biochemical Oxygen Demand
CAA -	Clean Air Act
CAAA -	Clean Air Act Amendments of 1990
CERCLA -	Comprehensive Environmental Response, Compensation and Liability Act
CERCLIS -	CERCLA Information System
CFCs -	Chlorofluorocarbons
CO -	Carbon Monoxide
COD -	Chemical Oxygen Demand
CSI -	Common Sense Initiative
CWA -	Clean Water Act
D&B -	Dun and Bradstreet Marketing Index
ELP -	Environmental Leadership Program
EPA -	United States Environmental Protection Agency
EPCRA -	Emergency Planning and Community Right-to-Know Act
FIFRA -	Federal Insecticide, Fungicide, and Rodenticide Act
FINDS -	Facility Indexing System
HAPs -	Hazardous Air Pollutants (CAA)
HSDB -	Hazardous Substances Data Bank
IDEA -	Integrated Data for Enforcement Analysis
LDR -	Land Disposal Restrictions (RCRA)
LEPCs -	Local Emergency Planning Committees
MACT -	Maximum Achievable Control Technology (CAA)
MCLGs -	Maximum Contaminant Level Goals
MCLs -	Maximum Contaminant Levels
MEK -	Methyl Ethyl Ketone
MSDSs -	Material Safety Data Sheets
NAAQS -	National Ambient Air Quality Standards (CAA)
NAFTA -	North American Free Trade Agreement
NCDB -	National Compliance Database (for TSCA, FIFRA, EPCRA)
NCP -	National Oil and Hazardous Substances Pollution Contingency Plan
NEIC -	National Enforcement Investigation Center
NESHAP -	National Emission Standards for Hazardous Air Pollutants
NO <sub>2</sub> -	Nitrogen Dioxide
NOV -	Notice of Violation
NO <sub>x</sub> -	Nitrogen Oxides
NPDES -	National Pollution Discharge Elimination System (CWA)

NPL -	National Priorities List
NRC -	National Response Center
NSPS -	New Source Performance Standards (CAA)
OAR -	Office of Air and Radiation
OECA -	Office of Enforcement and Compliance Assurance
OPA -	Oil Pollution Act
OPPTS -	Office of Prevention, Pesticides, and Toxic Substances
OSHA -	Occupational Safety and Health Administration
OSW -	Office of Solid Waste
OSWER -	Office of Solid Waste and Emergency Response
OW -	Office of Water
P2 -	Pollution Prevention
PCS -	Permit Compliance System (CWA Database)
POTW -	Publicly Owned Treatments Works
RCRA -	Resource Conservation and Recovery Act
RCRIS -	RCRA Information System
SARA -	Superfund Amendments and Reauthorization Act
SDWA -	Safe Drinking Water Act
SEPs -	Supplementary Environmental Projects
SERCs -	State Emergency Response Commissions
SIC -	Standard Industrial Classification
SO <sub>2</sub> -	Sulfur Dioxide
SO <sub>x</sub> -	Sulfur Oxides
TOC -	Total Organic Carbon
TRI -	Toxic Release Inventory
TRIS -	Toxic Release Inventory System
TCRIS -	Toxic Chemical Release Inventory System
TSCA -	Toxic Substances Control Act
TSS -	Total Suspended Solids
UIC -	Underground Injection Control (SDWA)
UST -	Underground Storage Tanks (RCRA)
VOCs -	Volatile Organic Compounds

**Message from the Administrator**



## I. INTRODUCTION TO THE SECTOR NOTEBOOK PROJECT

### I.A. Summary of the Sector Notebook Project

Environmental policies based upon comprehensive analysis of air, water and land pollution are an inevitable and logical supplement to traditional single-media approaches to environmental protection. Environmental regulatory agencies are beginning to embrace comprehensive, multi-statute solutions to facility permitting, enforcement and compliance assurance, education/outreach, research, and regulatory development issues. The central concepts driving the new policy direction are that pollutant releases to each environmental medium (air, water and land) affect every other, and that environmental strategies must actively identify and address these inter-relationships by designing policies for the "whole" facility. One way to achieve a whole facility focus is to design environmental policies for similar industrial facilities. By doing so, environmental concerns that are common to the manufacturing of similar products can be addressed in a comprehensive manner. Recognition of the need to develop the industrial "sector-based" approach within the EPA Office of Compliance led to the creation of this document.

The Sector Notebook Project was initiated by the Office of Compliance within the Office of Enforcement and Compliance Assurance (OECA) to provide its staff and managers with summary information for eighteen specific industrial sectors. As other EPA offices, states, the regulated community, environmental groups, and the public became interested in this project, the scope of the original project was expanded. The ability to design comprehensive, common sense environmental protection measures for specific industries is dependent on knowledge of several inter-related topics. For the purposes of this project, the key elements chosen for inclusion are: general industry information (economic and geographic); a description of industrial processes; pollution outputs; pollution prevention opportunities; Federal statutory and regulatory framework; compliance history; and a description of partnerships that have been formed between regulatory agencies, the regulated community and the public.

For any given industry, each topic listed above could alone be the subject of a lengthy volume. However, in order to produce a manageable document, this project focuses on providing summary information for each topic. This format provides the reader with a synopsis of each issue, and references where more in-depth information is available. Text within each profile was researched from a variety of sources, and was usually condensed from more detailed sources pertaining to specific topics. This approach allows for a wide coverage of activities that can be further explored based upon the citations

and references listed at the end of this profile. As a check on the information included, each notebook went through an external review process. The Office of Compliance appreciates the efforts of all those that participated in this process and enabled us to develop more complete, accurate and up-to-date summaries. Many of those who reviewed this notebook are listed as contacts in Section IX and may be sources of additional information. The individuals and groups on the list do not necessarily concur with all statements within this notebook.

## **I.B. Additional Information**

### **Providing Comments**

OECA's Office of Compliance plans to periodically review and update the notebooks and will make these updates available both in hard copy and electronically. If you have any comments on the existing notebook, or if you would like to provide additional information, please send a hard copy and computer disk to the EPA Office of Compliance, Sector Notebook Project, 401 M St., SW (2223-A), Washington, DC 20460. Comments can also be uploaded to the Enviro\$en\$e Bulletin Board or the Enviro\$en\$e World Wide Web for general access to all users of the system. Follow instructions in Appendix A for accessing these data systems. Once you have logged in, procedures for uploading text are available from the on-line Enviro\$en\$e Help System.

### **Adapting Notebooks to Particular Needs**

The scope of the existing notebooks reflect an approximation of the relative national occurrence of facility types that occur within each sector. In many instances, industries within specific geographic regions or states may have unique characteristics that are not fully captured in these profiles. For this reason, the Office of Compliance encourages state and local environmental agencies and other groups to supplement or re-package the information included in this notebook to include more specific industrial and regulatory information that may be available. Additionally, interested states may want to supplement the "Summary of Applicable Federal Statutes and Regulations" section with state and local requirements. Compliance or technical assistance providers may also want to develop the "Pollution Prevention" section in more detail. Please contact the appropriate specialist listed on the opening page of this notebook if your office is interested in assisting us in the further development of the information or policies addressed within this volume.

If you are interested in assisting in the development of new notebooks for sectors not covered in the original eighteen, please contact the Office of Compliance at 202-564-2395.

## II. INTRODUCTION TO THE PETROLEUM REFINING INDUSTRY

This section provides background information on the size, geographic distribution, employment, production, sales, and economic condition of the petroleum refining industry. The type of facilities described within the document are also described in terms of their Standard Industrial Classification (SIC) codes. Additionally, this section contains a list of the largest companies in terms of sales.

### II.A. Introduction, Background, and Scope of the Notebook

Petroleum refining is one of the leading manufacturing industries in the United States in terms of its share of the total value of shipments of the U.S. economy. In relation to its economic importance, however, the industry is comprised of relatively few companies and facilities. The number of refineries operating in the U.S. can vary significantly depending on the information source. For example, in 1992, the Census Bureau counted 232 facilities and the Department of Energy reported 199 facilities. In addition, EPA's Toxic Release Inventory for 1993 identified 159 refineries. The differences lie in each organization's definition of a refinery. The Census Bureau's definition is based on the type of product that a facility produces and includes a number of very small operations producing a specific petroleum product, such as lubricating oils, from other refined petroleum products. These small facilities often employ fewer than 10 people and account for only one to two of the petroleum refining industry's total value of shipments.<sup>1</sup> In comparison to the typically much more complex, larger and more numerous crude oil processing refineries, these facilities with their smaller and relatively simple operations do not warrant the same level of attention from an economic and environmental compliance standpoint. Refineries recognized by the Department of Energy tend to be only the larger facilities which process crude oil into refined petroleum products.<sup>a</sup>

Whenever possible, the facility level data used in this notebook are based on those refineries identified by the Department of Energy's Energy Information Administration. Since the Energy and Information Administration does not collect economic, employment and environmental release information on

---

<sup>a</sup> Variations in facility counts occur across data sources due to many factors including, reporting and definitional differences. This notebook does not attempt to reconcile these differences, but rather reports the data as they are maintained by each source.

refineries, other facility level data sources were used. Thus, employment and sales data are based on information collected through the Bureau of Census' Census of Manufacturers for 1992 and environmental release information was obtained from EPA's Toxic Release Inventory.

## II.B. Characterization of the Petroleum Refining Industry

### II.B.1. Product Characterization

Petroleum refining is the physical, thermal and chemical separation of crude oil into its major distillation fractions which are then further processed through a series of separation and conversion steps into finished petroleum products. The primary products of the industry fall into three major categories: fuels (motor gasoline, diesel and distillate fuel oil, liquefied petroleum gas, jet fuel, residual fuel oil, kerosene, and coke); finished nonfuel products (solvents, lubricating oils, greases, petroleum wax, petroleum jelly, asphalt, and coke); and chemical industry feedstocks (naphtha, ethane, propane, butane, ethylene, propylene, butylenes, butadiene, benzene, toluene, and xylene). These petroleum products comprise about 40 percent of the total energy consumed in the U.S.<sup>2</sup> (based on BTUs consumed) and are used as primary input to a vast number of products, including: fertilizers, pesticides, paints, waxes, thinners, solvents, cleaning fluids, detergents, refrigerants, anti-freeze, resins, sealants, insulations, latex, rubber compounds, hard plastics, plastic sheeting, plastic foam and synthetic fibers.<sup>3</sup> About 90 percent of the petroleum products used in the U.S. are fuels with motor gasoline accounting for about 43 percent of the total<sup>4</sup> (Exhibit 1).

The Standard Industrial Classification (SIC) code established by the Bureau of Census to track the flow of goods and services within the economy is 29 for the Petroleum Refining and Related Industries. The petroleum refining industry is classified as SIC 2911, which includes the production of petroleum products through distillation and fractionation of crude oil, redistillation of unfinished petroleum derivatives, cracking, or other processes. The related industries under SIC 29 are: 2951, Asphalt Paving Mixtures and Blocks; 2952, Asphalt Felts and Coatings; 2992, Lubricating Oils and Greases; and 2999, Petroleum and Coal Products, Not Elsewhere Classified. Certain products that are produced by the petroleum refining industry are also produced by other industries, including: 2865, Cyclic Organic Crudes and Intermediates, and Organic Dyes and Pigments; 2869, Industrial Organic Chemicals; 2819, Industrial Inorganic Chemicals, Not Elsewhere Classified; 2821, Plastic Materials, Synthetic Resins, Nonvulcanizable Elastomers; 2873, Nitrogenous Fertilizers; 4613, Refined Petroleum Pipelines; and 5171, Petroleum Bulk Stations and Terminals.<sup>5</sup>

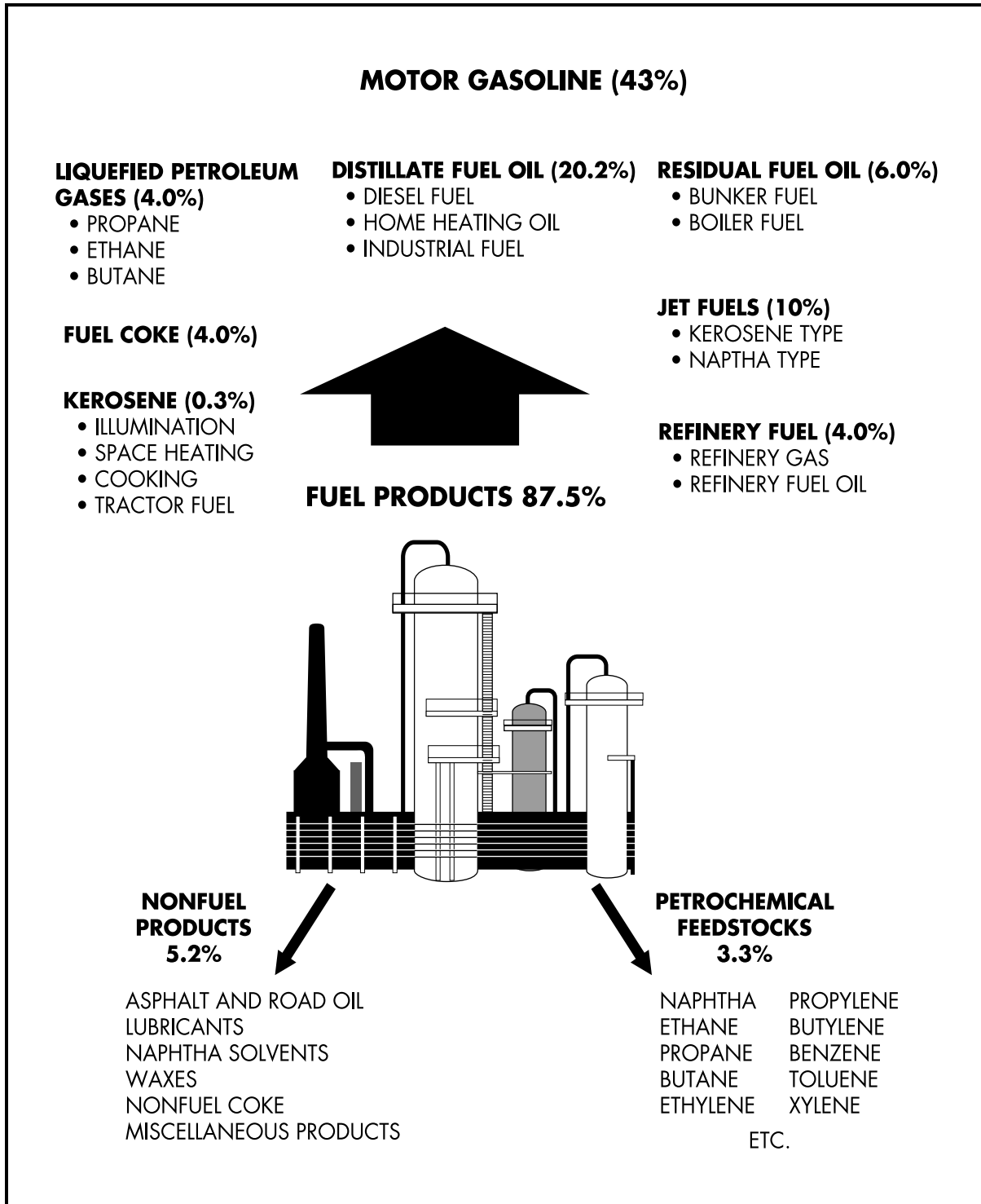

(Source: Based on Energy Information Administration, *The U.S. Petroleum Industry: Past as Prologue 1970-1992*, September 1993.)

**Exhibit 1: U.S. Refinery Products and Yields**

## II.B.2. Industry Size and Geographic Distribution

Generally, the petroleum refining industry can be characterized by a relatively small number of large facilities. The Department of Energy reported 176 operating petroleum refineries in 1994 with a total crude oil distillation capacity of approximately 15 million barrels per day. Most U.S. crude oil distillation capacity is owned by large, integrated companies with multiple high capacity refining facilities. Small refineries with capacities below 50,000 barrels per day, however, do play a significant role in the industry, making up about half of all facilities, but only 14 percent of the total crude distillation capacity.<sup>6</sup>

A relatively small number of people are employed by the petroleum refining industry in relation to its economic importance. The Bureau of the Census estimates that 75,000 people were directly employed by the industry in 1992.<sup>7</sup> However, the industry also indirectly employs a significant number of outside contractors for many refinery operations, both routine and non-routine. The value of product shipments sold by refining establishments was estimated to be \$136 billion in 1992. This accounts for about 4 percent of the value of shipments for the entire U.S. manufacturing sector.<sup>8</sup> Based on the number of people directly employed by refineries, the industry has a high value of shipments per employee of \$1.8 million. In comparison, the value of shipments per employee for the steel manufacturing industry was \$245,000 for the same year.<sup>9</sup>

The Bureau of Census employment data for 1992 (the most recent facility-based employment data available) indicated that 60 percent of petroleum refineries had over 100 employees<sup>10</sup> (Exhibit 2).

<b>Exhibit 2: Large Facilities Dominate Petroleum Refining Industry</b>		
Employees per Facility	Number of Facilities	Percentage of Facilities
1-4	17	7%
5-9	7	3%
10-19	11	5%
20-49	35	15%
50-99	22	10%
100-249	45	19%
250-499	49	21%
500-999	26	11%
1000-2499	20	9%
Total	232	100%
Source: Census of Manufacturers, 1992.		

For reasons of efficiency in transporting crude oil feed stocks and finished products, petroleum refineries typically were sited near crude oil sources (onshore petroleum terminals, oil and gas extraction areas) or consumers (heavily industrialized areas). Consequently, the distribution of facilities is more concentrated along the Gulf Coast and near the heavily industrialized areas of both east and west coasts (Exhibits 3 and 4). Based on Department of Energy data for 1994, 78 percent of the U.S. crude oil distillation capacity (which is indicative of the amount of crude oil processed) is located in just ten states<sup>11</sup> (Exhibit 3).

<b>Exhibit 3: Crude Oil Distillation Capacity Located Primarily Along Coasts</b>			
State	Number of Operable Refineries	Crude Distillation Capacity (thousand barrels per day)	Percent of U.S. Total Distillation Capacity
Texas	30	3,764	25%
Louisiana	19	2,360	16%
California	25	1,882	12%
Illinois	7	956	6%
Pennsylvania	8	655	4%
Washington	6	524	3%
Ohio	4	430	3%
New Jersey	4	462	3%
Indiana	2	421	3%
Oklahoma	7	404	3%
Subtotal	112	11,858	78%
Other States (also includes Virgin Islands and Puerto Rico)	64	3,355	22%
U.S. Total	176	15,213	100%
Source: U.S. Department of Energy/Energy Information Administration, 1994.			

### Exhibit 4

## U.S. Petroleum Refinery Distribution

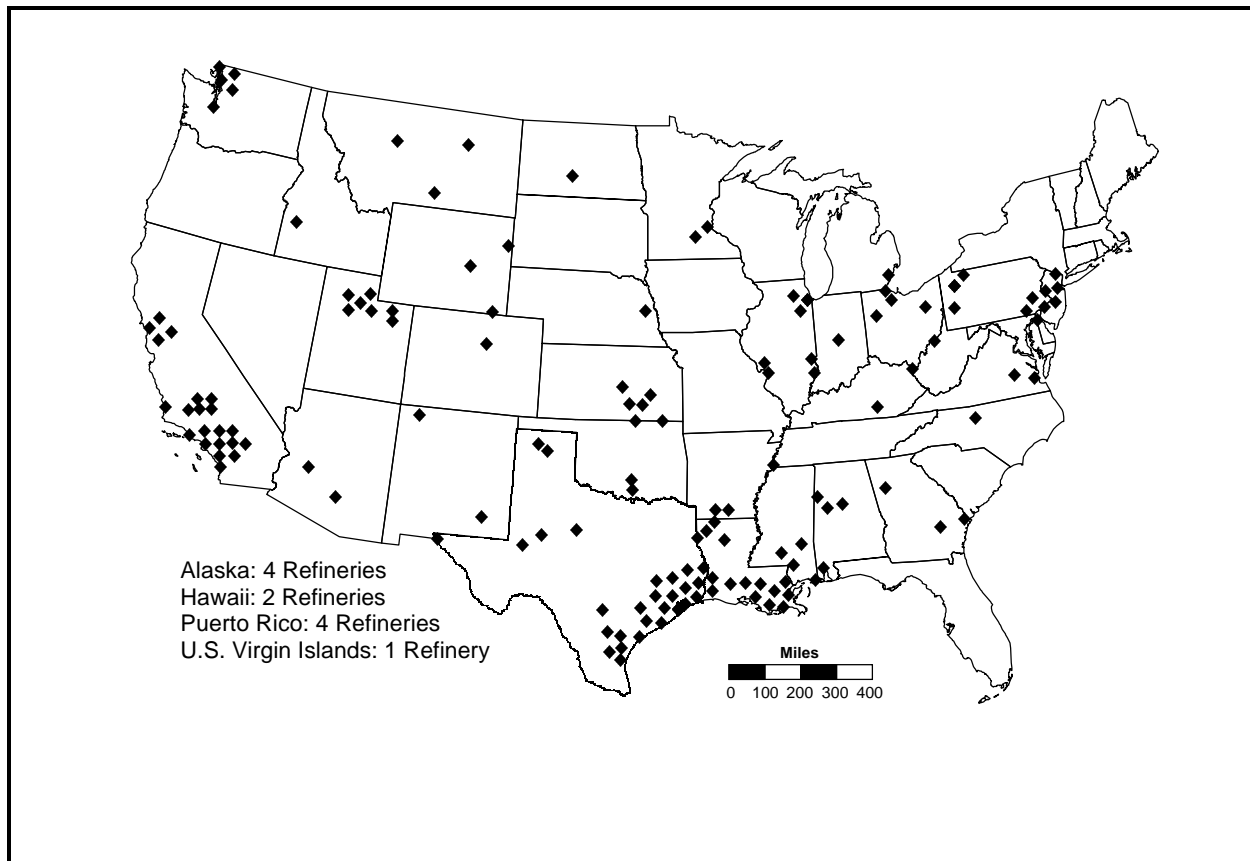

(Source: U.S. EPA Toxic Release Inventory Database, 1993.)

*Ward's Business Directory of U.S. Private and Public Companies*, produced by Gale Research Inc., compiles financial data on U.S. companies including those operating within the petroleum refining industry. Ward's ranks U.S. companies, whether they are a parent company, subsidiary or division, by sales volume within the 4-digit SIC codes that they have been assigned as their primary activity. Readers should note that: 1) companies are assigned a 4-digit SIC that most closely resembles their principal industry; and 2) sales figures include total company sales, including sales derived from subsidiaries and operations not related to petroleum refining. Additional sources of company specific financial information include Standard & Poor's *Stock Report Services*, Dun & Bradstreet's *Million Dollar Directory*, Moody's Manuals, and annual reports.

<b>Exhibit 5: Top U.S. Companies with Petroleum Refining Operations</b>		
<b>Rank<sup>a</sup></b>	<b>Company<sup>b</sup></b>	<b>1993 Sales (millions of dollars)</b>
1	Exxon Corporation - Irving TX	102,847
2	Mobil Corporation - Fairfax, VA	56,910
3	El du Pont de Nemours and Co. (Conoco Inc., Subsidiary) - Wilmington, DE	38,031
4	Texaco Inc. - White Plains, NY	37,271
5	Chevron Corporation - San Francisco, CA	35,523
6	Amoco Oil Corporation - Chicago, IL	22,320
7	Shell Oil Company - Houston, TX	22,201
8	Atlantic Richfield Company - Los Angeles, CA	18,922
9	BP America Incorporated - Cleveland, OH	16,200
10	Caltex Petroleum Corporation - Dallas, TX	15,100

Note: <sup>a</sup> When Ward's Business Directory listed both a parent and subsidiary in the top ten, only the parent company is presented above to avoid double counting sales volumes. Not all sales can be attributed to the companies' petroleum refining operations.  
<sup>b</sup> Companies shown listed SIC 2911 as primary activity.

Source: Ward's Business Directory of U.S. Private and Public Companies - 1993.

### II.B.3. Economic Trends

The United States is a net importer of crude oil and petroleum products. In 1994, imports accounted for more than 50 percent of the crude oil used in the U.S. and about 10 percent of finished petroleum products.<sup>12</sup> The imported share of crude oil is expected to increase as U.S. demand for petroleum products increases and the domestic production of crude oil declines. Imported finished petroleum products serve specific market niches arising from logistical considerations, regional shortages, and long-term trade relations between suppliers and refiners. Exports of refined petroleum products, which primarily consist of petroleum coke, residual fuel oil, and distillate fuel oil, account for about four percent of the U.S. refinery output. Exports of crude oil produced in the U.S. account for about one percent of the total U.S. crude oil produced and imported.<sup>13</sup>

The petroleum refining industry in the U.S. has felt considerable economic pressures in the past decade arising from a number of factors including: increased costs of labor; compliance with new safety and environmental regulations; and the elimination of government subsidies through the Crude Oil Entitlements Program which had encouraged smaller refineries to add capacity throughout the 1970s.<sup>14</sup> A rationalization period began after crude oil pricing and entitlements were decontrolled in early 1981. The market determined that there was surplus capacity and the margins dropped to encourage the closure of the least efficient capacity. Reflecting these pressures, numerous facilities have closed in recent years.<sup>15</sup> Between 1982 and 1994, the number of U.S. refineries as determined by the Department of Energy dropped from 301 to 176. Most of these closures have involved small facilities refining less than 50,000 barrels of crude oil per day. Some larger facilities, however, have also closed in response to economic pressures.<sup>16</sup> Industry representatives cited complying with the increasing environmental regulations, particularly, the requirements of the Clean Air Act Amendments of 1990, as the most important factor affecting petroleum refining in the 1990s.<sup>17</sup> Despite the closing of refineries in recent years, total refinery output of finished products has remained relatively steady with slight increases in the past two years. Increases in refinery outputs are attributable to higher utilization rates of refinery capacity, and to incremental additions to the refining capacity at existing facilities as opposed to construction of new refineries.<sup>18</sup>

Demand for refined petroleum products is expected to increase slowly through 1998 with the growth of the U.S. economy. The rate of increase will average about 1.5 percent per year, which is slower than the expected growth of the economy. This slower rate of increase of demand will be due to increasing prices of petroleum products as a result of conservation, the development of substitutes for petroleum products, and rising costs of compliance with environmental and safety requirements.<sup>19</sup>

Recent and future environmental and safety regulatory changes are expected to force the petroleum refining industry to make substantial investments in upgrading certain refinery processes to reduce emissions and alter product compositions. For example, industry estimates of the capital costs to comply with the 1990 Clean Air Act Amendments, which mandates specific product compositions are about \$35 to \$40 billion.<sup>20</sup> There is concern that in some cases it may be more economical for some refineries to close down partially or entirely rather than upgrade facilities to meet the new standards. In fact, the U.S. Departments of Energy and Commerce expect refinery shutdowns to continue through the 1990s; however, total crude oil distillation capacity is expected to remain relatively stable as a result of increased capacity and

utilization rates at existing facilities. Increases in demand for finished petroleum products will be filled by increased imports.

### III. INDUSTRIAL PROCESS DESCRIPTION

This section describes the major industrial processes within the petroleum refining industry, including the materials and equipment used, and the processes employed. The section is designed for those interested in gaining a general understanding of the industry, and for those interested in the inter-relationship between the industrial process and the topics described in subsequent sections of this profile -- pollutant outputs, pollution prevention opportunities, and Federal regulations. This section does not attempt to replicate published engineering information that is available for this industry. Refer to Section IX for a list of reference documents that are available.

This section specifically contains a description of commonly used production processes, associated raw materials, the byproducts produced or released, and the materials either recycled or transferred off-site. This discussion, coupled with schematic drawings of the identified processes, provide a concise description of where wastes may be produced in the process. This section also describes the potential fate (via air, water, and soil pathways) of these waste products.

#### III.A. Industrial Processes in the Petroleum Refining Industry

Crude oil is a mixture of many different hydrocarbons and small amounts of impurities. The composition of crude oil can vary significantly depending on its source. Petroleum refineries are a complex system of multiple operations and the operations used at a given refinery depend upon the properties of the crude oil to be refined and the desired products. For these reasons, no two refineries are alike. Portions of the outputs from some processes are re-fed back into the same process, fed to new processes, fed back to a previous process, or blended with other outputs to form finished products (Exhibit 6). The major unit operations typically involved at petroleum refineries are described briefly below. In addition to those listed below, there are also many special purpose processes that cannot be described here and which may play an important role in a facility's efforts to comply with pollutant discharge and product specification requirements.

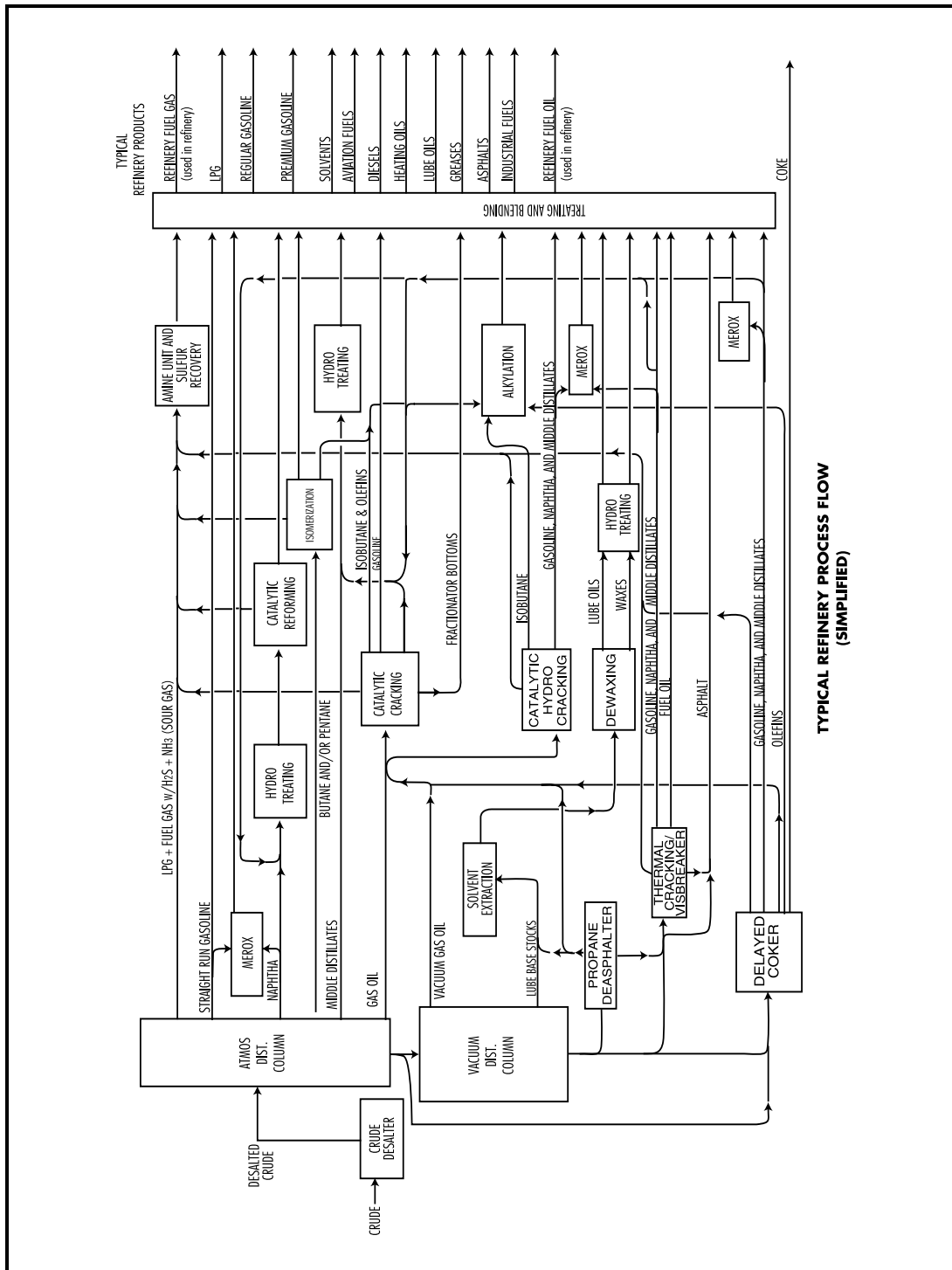

(Source: Based on Gary & Handwerk, *Petroleum Refining Technology and Economics*, 3rd Edition, Marcel & Dekker, Inc., New York, NY, 1994.)

**Exhibit 6: Simplified Process Flow Diagram of Typical Refinery**

Refining crude oil into useful petroleum products can be separated into two phases and a number of supporting operations. The first phase is desalting of crude oil and the subsequent distillation into its various components or "fractions" (Section III.A.1). The second phase is made up of three different types of "downstream" processes: combining, breaking, and reshaping (Section III.A.2). Downstream processes convert some of the distillation fractions into petroleum products (residual fuel oil, gasoline, kerosene, etc.) through any combination of different cracking, coking, reforming, and alkylation processes. Supporting operations may include wastewater treatment, sulfur recovery, additive production, heat exchanger cleaning, blowdown systems, blending of products, and storage of products (Section III.A.3). Refinery pollutant outputs are discussed in more detail in Section III.B.

### III.A.1. Crude Oil Distillation and Desalting

One of the most important operations in a refinery is the initial distillation of the crude oil into its various boiling point fractions. Distillation involves the heating, vaporization, fractionation, condensation, and cooling of feedstocks. This section discusses the atmospheric and vacuum distillation processes which when used in sequence result in lower costs and higher efficiencies. This section also discusses the important first step of desalting the crude oil prior to distillation.

#### *Desalting*

Before separation into fractions, crude oil usually must first be treated to remove corrosive salts. The desalting process also removes some of the metals and suspended solids which cause catalyst deactivation. Desalting involves the mixing of heated crude oil with water (about three to 10 percent of the crude oil volume) so that the salts are dissolved in the water.<sup>21</sup> The water must then be separated from the crude oil in a separating vessel by adding demulsifier chemicals to assist in breaking the emulsion and/or, more commonly, by applying a high potential electric field across the settling vessel to coalesce the polar salt water droplets. The desalting process creates an oily desalter sludge and a high temperature salt water waste stream which is typically added to other process wastewaters for treatment in the refinery wastewater treatment facilities. The water used in crude desalting is often untreated or partially treated water from other refining process water sources.<sup>22</sup>

#### *Atmospheric Distillation*

The desalted crude oil is then heated in a heat exchanger and furnace to about 750 degrees (F) and fed to a vertical, distillation column at atmospheric pressure where most of the feed is vaporized and separated into its various fractions by condensing on 30 to 50 fractionation trays, each corresponding to a different condensation temperature. The lighter fractions condense and are collected towards the top of the column. Heavier fractions, which may not vaporize in the column, are further separated later by vacuum distillation. Within each atmospheric distillation tower, a number of side streams (at least four) of low-boiling point components are removed from the tower from different trays. These low-boiling point mixtures are in equilibrium with heavier components which must be removed. The side streams are each sent to a different small stripping tower containing four to 10 trays with steam injected under the bottom tray. The steam strips the light-end components from the heavier components and both the steam and light-ends are fed back to the atmospheric distillation tower above the corresponding side stream draw tray.<sup>23</sup> Fractions obtained from atmospheric distillation include naphtha, gasoline, kerosene, light fuel oil, diesel oils, gas oil, lube distillate, and heavy bottoms. Most of these can be sold as finished products, or blended with products from downstream processes. Another product produced in atmospheric distillation, as well as many other refinery processes, is the light, noncondensable refinery fuel gas (mainly methane and ethane). Typically this gas also contains hydrogen sulfide and ammonia gases. The mixture of these gases is known as "sour gas" or "acid gas." The sour gas is sent to the refinery sour gas treatment system which separates the fuel gas so that it can be used as fuel in the refinery heating furnaces. Air emissions during atmospheric distillation arise from the combustion of fuels in the furnaces to heat the crude oil, process vents and fugitive emissions. Oily sour water (condensed steam containing hydrogen sulfate and ammonia) and oil is also generated in the fractionators<sup>24</sup> (Exhibit 7).

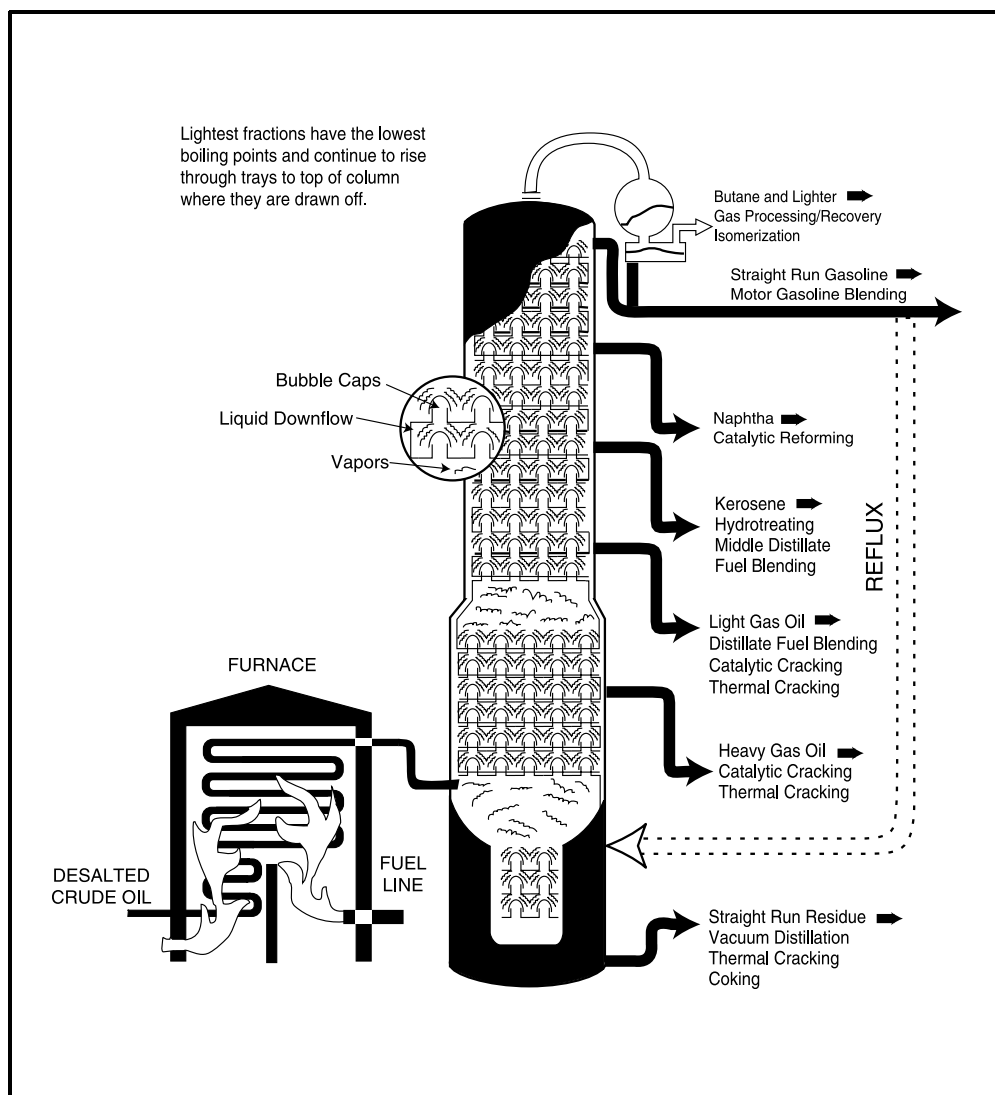

(Source: Based on Energy Information Administration, *The U.S. Petroleum Industry: Past as Prologue 1970-1992*, September 1993.)

## Exhibit 7: Crude Oil Distillation

### *Vacuum Distillation*

Heavier fractions from the atmospheric distillation unit that cannot be distilled without cracking under its pressure and temperature conditions are vacuum distilled. Vacuum distillation is simply the distillation of petroleum fractions at a very low pressure (0.2 to 0.7 psia) to increase volatilization and separation. In most systems, the vacuum inside the fractionator is maintained with steam ejectors and vacuum pumps, barometric condensers or surface

condensers. The injection of superheated steam at the base of the vacuum fractionator column further reduces the partial pressure of the hydrocarbons in the tower, facilitating vaporization and separation. The heavier fractions from the vacuum distillation column are processed downstream into more valuable products through either cracking or coking operations (See Section III.A.2.).<sup>25</sup>

A potential source of emissions from distillation of crude oil are the combustion of fuels in the furnace and some light gases leaving the top of the condensers on the vacuum distillation column. A certain amount of noncondensable light hydrocarbons and hydrogen sulfide pass through the condenser to a hot well, and then are discharged to the refinery sour fuel system or are vented to a process heater, flare or another control device to destroy hydrogen sulfide. The quantity of these emissions depends on the size of the unit, the type of feedstock, and the cooling water temperature.<sup>26</sup> If barometric condensers are used in vacuum distillation, significant amounts of oily wastewater can be generated. Vacuum pumps and surface condensers have largely replaced barometric condensers in many refineries to eliminate this oily wastewater stream. Oily sour water is also generated in the fractionators.<sup>27</sup>

### III.A.2. Downstream Processing

Certain fractions from the distillation of crude oil are further refined in thermal cracking (visbreaking), coking, catalytic cracking, catalytic hydrocracking, hydrotreating, alkylation, isomerization, polymerization, catalytic reforming, solvent extraction, merox, dewaxing, propane deasphalting and other operations. These downstream processes change the molecular structure of hydrocarbon molecules either by breaking them into smaller molecules, joining them to form larger molecules, or reshaping them into higher quality molecules. For many of the operations discussed below, a number of different techniques are used in the industry. While the major techniques used for each process are described, it was not possible to discuss all of the different processes currently in use.

#### *Thermal Cracking/Visbreaking*

Thermal cracking, or visbreaking, uses heat and pressure to break large hydrocarbon molecules into smaller, lighter molecules. The process has been largely replaced by catalytic cracking and some refineries no longer employ thermal cracking. Both processes reduce the production of less valuable products such as heavy fuel oil and cutter stock and increase the feed stock to the catalytic cracker and gasoline yields. In thermal cracking, heavy gas oils and residue from the vacuum distillation process are typically the feed

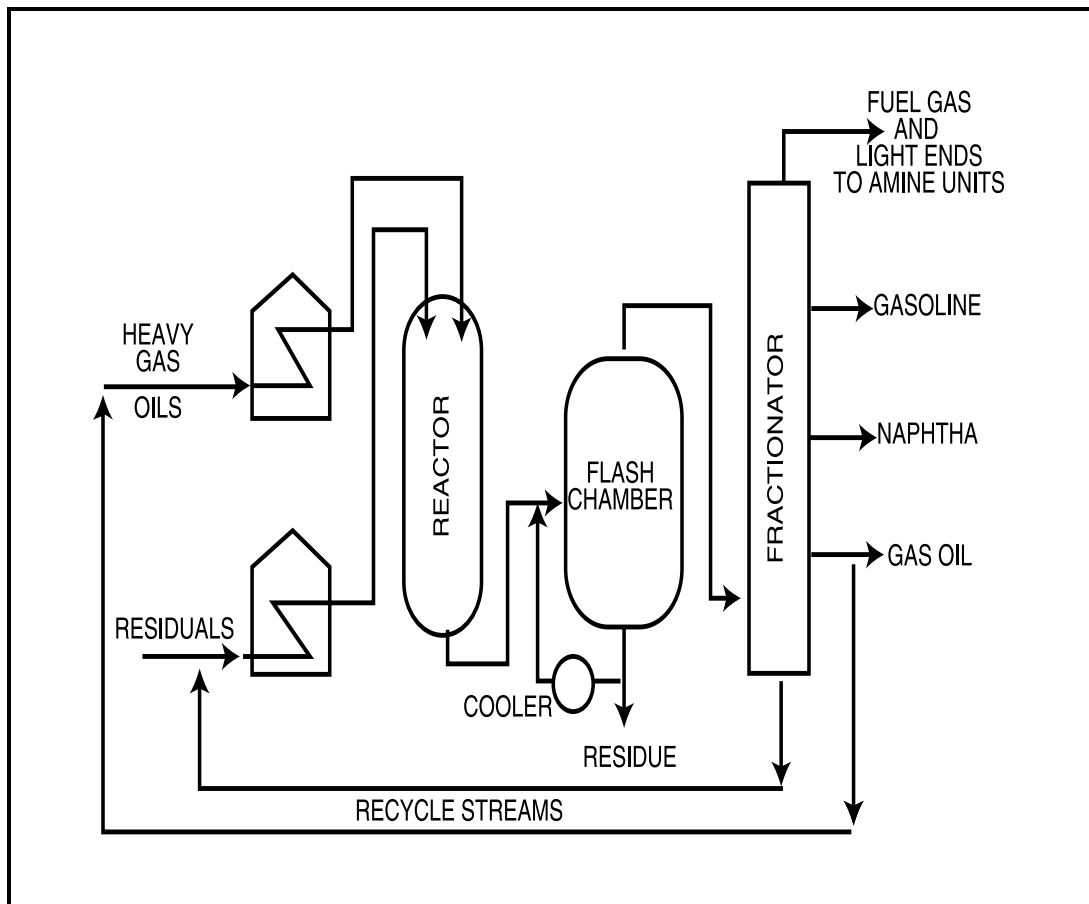

(Source: Based on Gary & Handwerk, *Petroleum Refining Technology and Economics*, 3rd Edition, Marcel Dekker, Inc., New York, NY, 1994, and U.S. EPA Office of General Enforcement, *Petroleum Refinery Enforcement Manual*, 1990.)

### Exhibit 8: Simplified Thermal Cracker Flow Diagram

stocks. The feed stock is heated in a furnace or other thermal unit to up to 1,000 degrees (F) and then fed to a reaction chamber which is kept at a pressure of about 140 psig. Following the reactor step, the process stream is mixed with a cooler recycle stream, which stops the cracking reactions. The product is then fed to a flasher chamber, where pressure is reduced and lighter products vaporize and are drawn off. The lighter products are fed to a fractionating tower where the various fractions are separated. The "bottoms" consist of heavy residue, part of which is recycled to cool the process stream leaving the reaction chamber; the remaining bottoms are usually blended into residual fuel (Exhibit 8).<sup>28</sup>

Air emissions from thermal cracking include emissions from the combustion of fuels in the process heater, vents, and fugitive emissions.<sup>29</sup> A sour water stream is generated in the fractionator.<sup>30</sup>

*Coking*

Coking is a cracking process used primarily to reduce refinery production of low-value residual fuel oils to transportation fuels, such as gasoline and diesel. As part of the upgrading process, coking also produces petroleum coke, which is essentially solid carbon with varying amounts of impurities, and is used as a fuel for power plants if the sulfur content is low enough. Coke also has nonfuel applications as a raw material for many carbon and graphite products including anodes for the production of aluminum, and furnace electrodes for the production of elemental phosphorus, titanium dioxide, calcium carbide and silicon carbide.<sup>31</sup> A number of different processes are used to produce coke; "delayed coking" is the most widely used today, but "fluid coking" is expected to be an important process in the future. Fluid coking produces a higher grade of coke which is increasingly in demand. In delayed coking operations, the same basic process as thermal cracking is used except feed streams are allowed to react longer without being cooled. The delayed coking feed stream of residual oils from various upstream processes is first introduced to a fractionating tower where residual lighter materials are drawn off and the heavy ends are condensed. The heavy ends are removed and heated in a furnace to about 900 - 1,000 degrees (F) and then fed to an insulated vessel called a coke drum where the coke is formed. When the coke drum is filled with product, the feed is switched to an empty parallel drum. Hot vapors from the coke drums, containing cracked lighter hydrocarbon products, hydrogen sulfide, and ammonia, are fed back to the fractionator where they can be treated in the sour gas treatment system or drawn off as intermediate products. Steam is then injected into the full coke drum to remove hydrocarbon vapors, water is injected to cool the coke, and the coke is removed. Typically, high pressure water jets are used to cut the coke from the drum (Exhibit 9).<sup>32</sup>

Air emissions from coking operations include the process heater flue gas emissions, fugitive emissions and emissions that may arise from the removal of the coke from the coke drum. The injected steam is condensed and the remaining vapors are typically flared. Wastewater is generated from the coke removal and cooling operations and from the steam injection. In addition, the removal of coke from the drum can release particulate emissions and any remaining hydrocarbons to the atmosphere.

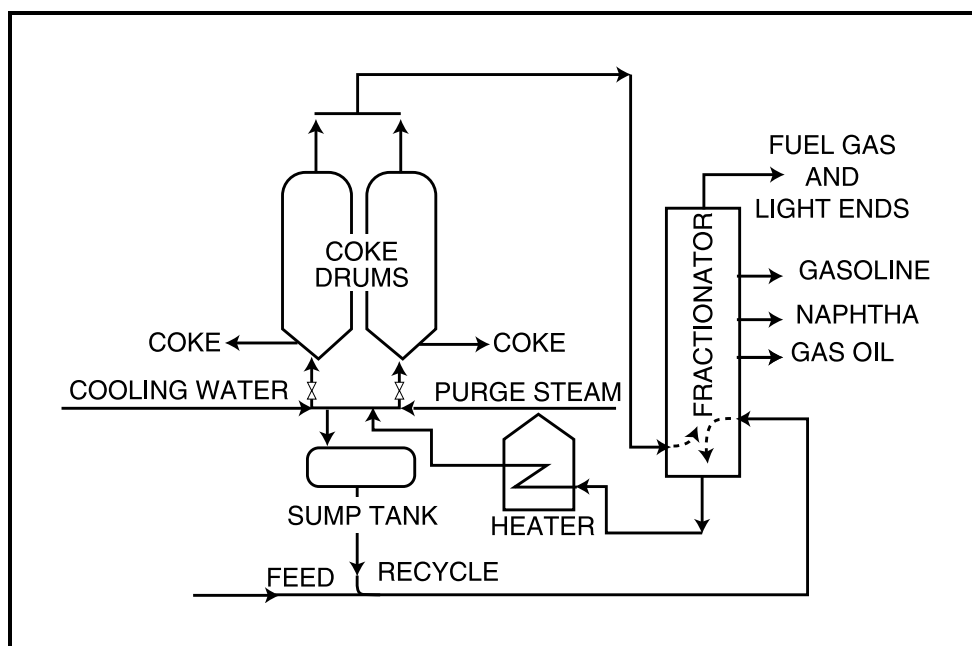

(Source: Based on U.S. EPA Office of General Enforcement, *Petroleum Refinery Enforcement Manual*, 1980.)

### Exhibit 9: Simplified Coker Flow Diagram

#### *Catalytic Cracking*

Catalytic cracking uses heat, pressure and a catalyst to break larger hydrocarbon molecules into smaller, lighter molecules. Catalytic cracking has largely replaced thermal cracking because it is able to produce more gasoline with a higher octane and less heavy fuel oils and light gases. Feed stocks are light and heavy oils from the crude oil distillation unit which are processed primarily into gasoline as well as some fuel oil and light gases. Most catalysts used in catalytic cracking consist of mixtures of crystalline synthetic silica-alumina, termed "zeolites," and amorphous synthetic silica-alumina. The catalytic cracking processes, as well as most other refinery catalytic processes, produce coke which collects on the catalyst surface and diminishes its catalytic properties. The catalyst, therefore, needs to be regenerated continuously or periodically essentially by burning the coke off the catalyst at high temperatures. The method and frequency in which catalysts are regenerated are a major factor in the design of catalytic cracking units. A number of different catalytic cracking designs are currently in use in the U.S., including fixed-bed reactors, moving-bed reactors, fluidized-bed reactors, and once-through units. The fluidized- and moving-bed reactors are by far the most prevalent.<sup>33</sup>

Fluidized-bed catalytic cracking units (FCCUs) are by far the most common catalytic cracking units. In the fluidized-bed process, oil and oil vapor preheated to 500 to 800 degrees (F) is contacted with hot catalyst at about 1,300 (F) either in the reactor itself or in the feed line (riser) to the reactor. The catalyst is in a fine, granular form which, when mixed with the vapor, has many of the properties of a fluid. The fluidized catalyst and the reacted hydrocarbon vapor separate mechanically in the reactor and any oil remaining on the catalyst is removed by steam stripping. The cracked oil vapors are then fed to a fractionation tower where the various desired fractions are separated and collected. The catalyst flows into a separate vessel(s) for either single- or two-stage regeneration by burning off the coke deposits with air (Exhibit 10).<sup>34</sup>

In the moving-bed process, oil is heated to up to 1,300 degrees (F) and is passed under pressure through the reactor where it comes into contact with a catalyst flow in the form of beads or pellets. The cracked products then flow to a fractionating tower where the various compounds are separated and collected. The catalyst is regenerated in a continuous process where deposits of coke on the catalyst are burned off. Some units also use steam to strip remaining hydrocarbons and oxygen from the catalyst before being fed back to the oil stream. In recent years moving-bed reactors have largely been replaced by fluidized-bed reactors.<sup>35</sup>

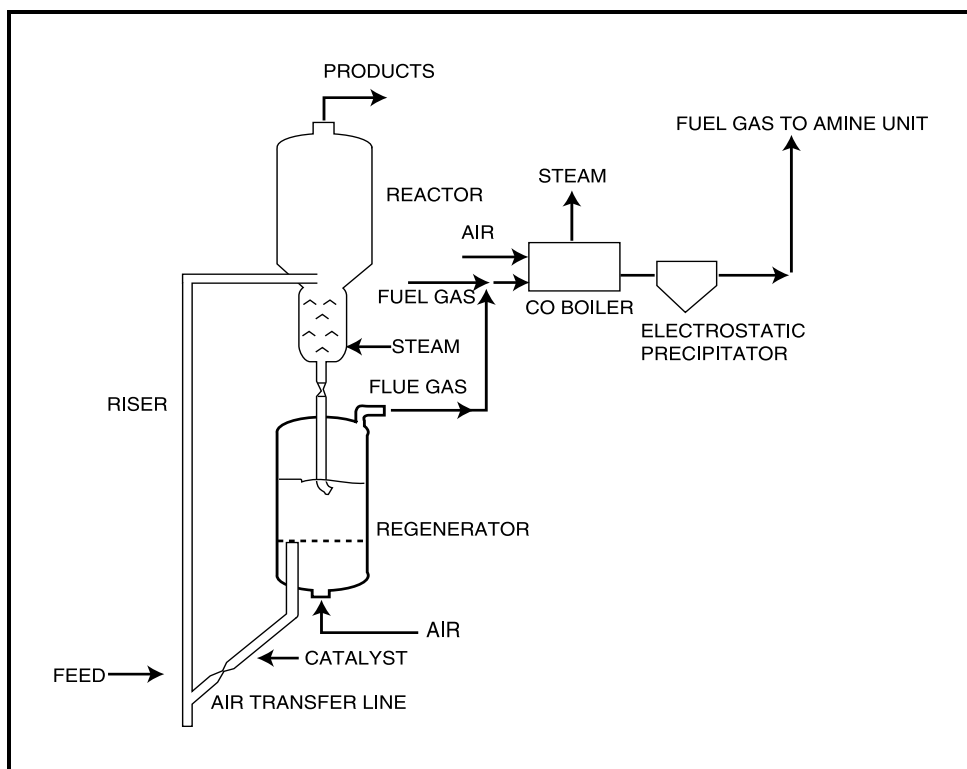

(Source: Based on U.S. EPA Office of General Enforcement, *Petroleum Refinery Enforcement Manual*, 1980.)

### Exhibit 10: Simplified Catalytic Cracking Flow Diagram

Catalytic cracking is one of the most significant sources of air pollutants at refineries. Air emissions from catalytic cracking operations include: the process heater flue gas emissions, fugitive emissions, and emissions generated during regeneration of the catalyst. Relatively high concentrations of carbon monoxide can be produced during regeneration of the catalyst which is typically converted to carbon dioxide either in the regenerator or further downstream in a carbon monoxide waste heat boiler.<sup>36</sup> In addition, a significant amount of fine catalyst dust is produced in FCCUs as a result of the constant movement of the catalyst grains against each other. Much of this dust, consisting primarily of alumina and relatively small amounts of nickel, is carried with the carbon monoxide stream to the carbon monoxide burner. The catalyst dust is then separated from the resulting carbon dioxide stream via cyclones and/or electrostatic precipitators and is sent off-site for disposal or treatment.<sup>37</sup> Generated wastewater is typically sour water from the fractionator containing some oil and phenols. Wastewater containing metal

impurities from the feed oil can also be generated from the steam used to purge and regenerate catalysts.<sup>38</sup>

### *Catalytic Hydrocracking*

Catalytic hydrocracking normally utilizes a fixed-bed catalytic cracking reactor with cracking occurring under substantial pressure (1,200 to 2,000 psig) in the presence of hydrogen. Feedstocks to hydrocracking units are often those fractions that are the most difficult to crack and cannot be cracked effectively in catalytic cracking units. These include: middle distillates, cycle oils, residual fuel oils and reduced crudes. The hydrogen suppresses the formation of heavy residual material and increases the yield of gasoline by reacting with the cracked products. However, this process also breaks the heavy, sulfur and nitrogen bearing hydrocarbons and releases these impurities to where they could potentially foul the catalyst. For this reason, the feedstock is often first hydrotreated to remove impurities before being sent to the catalytic hydrocracker. Sometimes hydrotreating is accomplished by using the first reactor of the hydrocracking process to remove impurities. Water also has a detrimental effect on some hydrocracking catalysts and must be removed before being fed to the reactor. The water is removed by passing the feed stream through a silica gel or molecular sieve dryer. Depending on the products desired and the size of the unit, catalytic hydrocracking is conducted in either single stage or multi-stage reactor processes. Most catalysts consist of a crystalline mixture of silica-alumina with small amounts of rare earth metals (Exhibit 11).<sup>39</sup>

Hydrocracking feedstocks are usually first hydrotreated to remove the hydrogen sulfide and ammonia that will poison the catalyst. Sour gas and sour water streams are produced at the fractionator, however, if the hydrocracking feedstocks are first hydrotreated to remove impurities, both streams will contain relatively low levels of hydrogen sulfide and ammonia. Hydrocracking catalysts are typically regenerated off-site after two to four years of operation. Therefore, little or no emissions are generated from the regeneration processes. Air emissions arise from the process heater, vents, and fugitive emissions.<sup>40,41</sup>

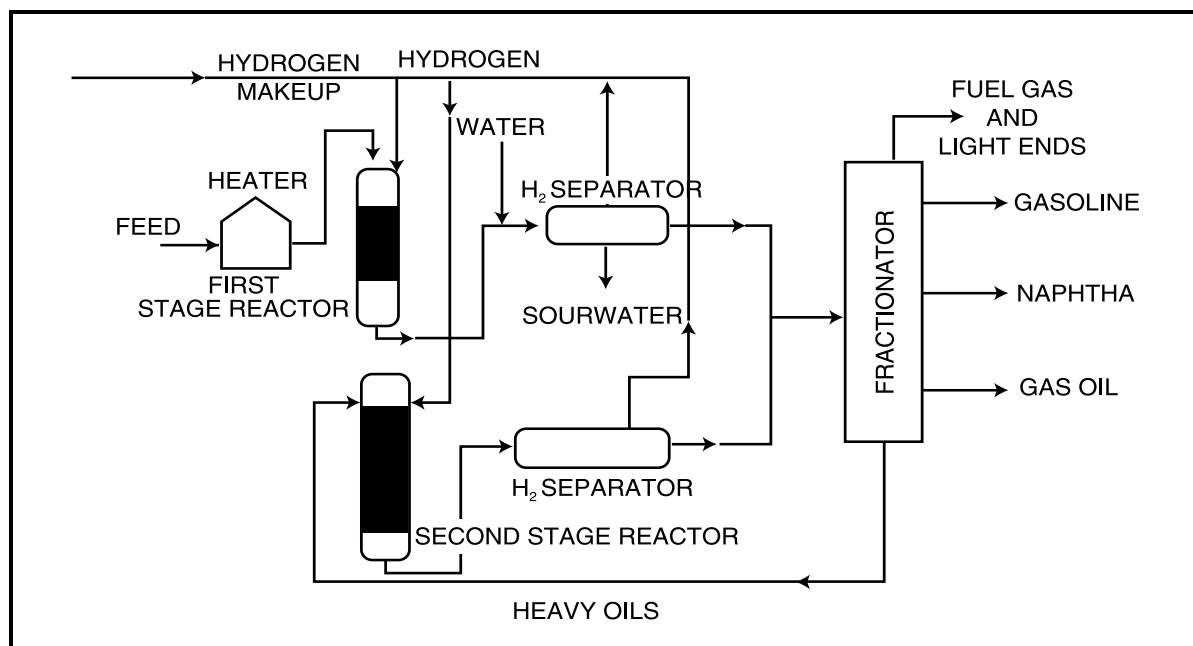

(Source: Based on U.S. EPA Office of General Enforcement, *Petroleum Refinery Enforcement Manual*, 1980.)

### Exhibit 11: Simplified Two-Stage Hydrocracker Flow Diagram

#### *Hydrotreating/Hydroprocessing*

Hydrotreating and hydroprocessing are similar processes used to remove impurities such as sulfur, nitrogen, oxygen, halides and trace metal impurities that may deactivate process catalysts. Hydrotreating also upgrades the quality of fractions by converting olefins and diolefins to paraffins for the purpose of reducing gum formation in fuels. Hydroprocessing, which typically uses residuals from the crude distillation units, also cracks these heavier molecules to lighter more saleable products. Both hydrotreating and hydroprocessing units are usually placed upstream of those processes in which sulfur and nitrogen could have adverse effects on the catalyst, such as catalytic reforming and hydrocracking units. The processes utilize catalysts in the presence of substantial amounts of hydrogen under high pressure and temperature to react the feedstocks and impurities with hydrogen. The reactors are nearly all fixed-bed with catalyst replacement or regeneration done after months or years of operation often at an off-site facility.<sup>42</sup> In addition to the treated products, the process produces a stream of light fuel gases, hydrogen sulfide, and ammonia. The treated product and hydrogen-rich gas are cooled after they leave the reactor before being separated. The hydrogen is recycled to the reactor.

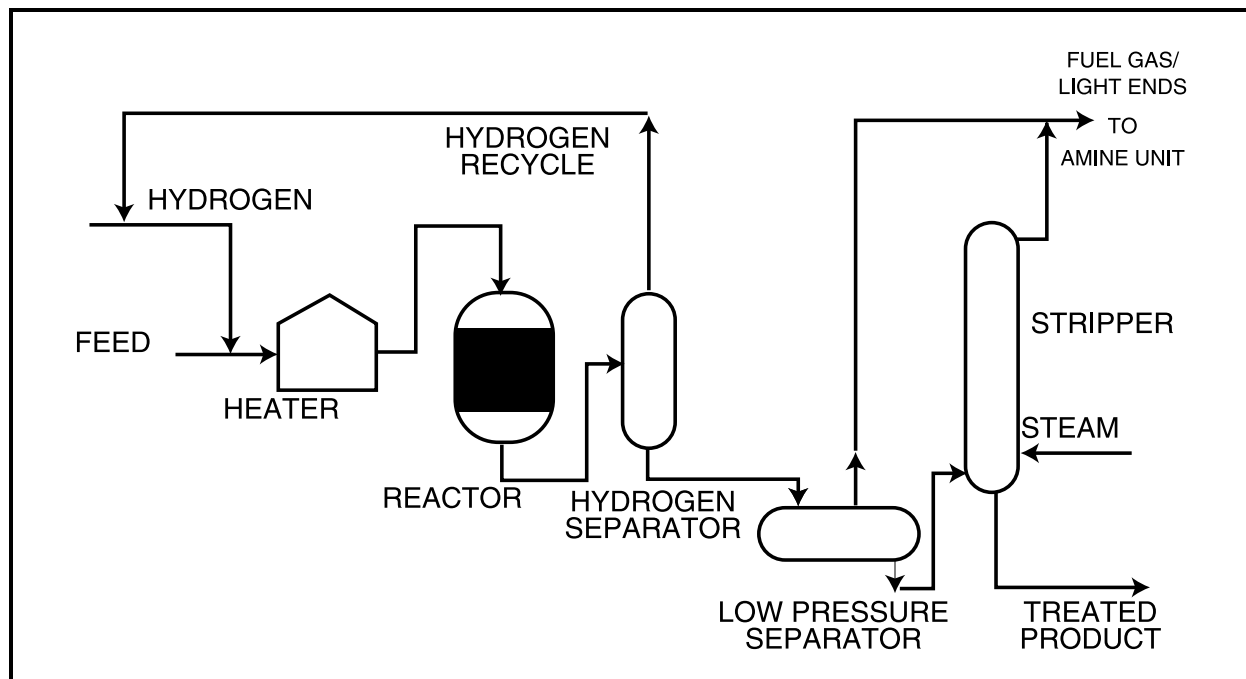

(Source: U.S. EPA Office of General Enforcement, *Petroleum Refinery Enforcement Manual*, 1980.)

### Exhibit 12: Simplified Hydrotreater Flow Diagram

The off-gas stream may be very rich in hydrogen sulfide and light fuel gas. The fuel gas and hydrogen sulfide are typically sent to the sour gas treatment unit and sulfur recovery unit. Catalysts are typically cobalt or molybdenum oxides on alumina, but can also contain nickel and tungsten. Air emissions from hydrotreating may arise from process heater flue gas, vents, and fugitive emissions (Exhibit 12).<sup>43</sup>

#### *Alkylation*

Alkylation is used to produce a high octane gasoline blending stock from the isobutane formed primarily during catalytic cracking and coking operations, but also from catalytic reforming, crude distillation and natural gas processing. Alkylation joins an olefin and an isoparaffin compound using either a sulfuric acid or hydrofluoric acid catalyst. The products are alkylates including propane and butane liquids. When the concentration of acid becomes less than 88 percent, some of the acid must be removed and replaced with stronger acid. In the hydrofluoric acid process, the slip stream of acid is redistilled. Dissolved polymerization products are removed from the acid as a thick dark oil. The concentrated hydrofluoric acid is recycled and the net consumption is about 0.3 pounds per barrel of alkylates produced. Hydrofluoric acid alkylation units require special engineering design, operator

training and safety equipment precautions to protect operators from accidental contact with hydrofluoric acid which is an extremely hazardous substance. In the sulfuric acid process, the sulfuric acid removed must be regenerated in a sulfuric acid plant which is generally not a part of the alkylation unit and may be located off-site. Spent sulfuric acid generation is substantial; typically in the range of 13 to 30 pounds per barrel of alkylate.<sup>44</sup> Air emissions from the alkylation process may arise from process vents and fugitive emissions.

### *Isomerization*

Isomerization is used to alter the arrangement of a molecule without adding or removing anything from the original molecule. Typically, paraffins (butane or pentane from the crude distillation unit) are converted to isoparaffins having a much higher octane. Isomerization reactions take place at temperatures in the range of 200 to 400 degrees (F) in the presence of a catalyst that usually consists of platinum on a base material. Two types of catalysts are currently in use. One requires the continuous addition of small amounts of organic chlorides which are converted to hydrogen chloride in the reactor. In such a reactor, the feed must be free of oxygen sources including water to avoid deactivation and corrosion problems. The other type of catalyst uses a molecular sieve base and does not require a dry and oxygen free feed. Both types of isomerization catalysts require an atmosphere of hydrogen to minimize coke deposits; however, the consumption of hydrogen is negligible. Catalysts typically need to be replaced about every two to three years or longer.<sup>45</sup> Platinum is then recovered from the used catalyst off-site. Light ends are stripped from the product stream leaving the reactor and are then sent to the sour gas treatment unit. Some isomerization units utilize caustic treating of the light fuel gas stream to neutralize any entrained hydrochloric acid. This will result in a calcium chloride (or other salts) waste stream. Air emissions may arise from the process heater, vents and fugitive emissions.<sup>46</sup> Wastewater streams include caustic wash and sour water.<sup>47</sup>

### *Polymerization*

Polymerization is occasionally used to convert propene and butene to high octane gasoline blending components. The process is similar to alkylation in its feed and products, but is often used as a less expensive alternative to alkylation. The reactions typically take place under high pressure in the presence of a phosphoric acid catalyst. The feed must be free of sulfur, which poisons the catalyst; basic materials, which neutralize the catalyst; and oxygen, which affects the reactions. The propene and butene feed is washed first with caustic to remove mercaptans (molecules containing sulfur), then with an amine solution to remove hydrogen sulfide, then with water to remove caustics and amines, and finally dried by passing through a silica gel or

molecular sieve dryer.<sup>48</sup> Air emissions of sulfur dioxide may arise during the caustic washing operation. Spent catalyst, which typically is not regenerated, is occasionally disposed as a solid waste.<sup>49</sup> Wastewater streams will contain caustic wash and sour water with amines and mercaptans.<sup>50</sup>

### *Catalytic Reforming*

Catalytic reforming uses catalytic reactions to process primarily low octane heavy straight run (from the crude distillation unit) gasolines and naphthas into high octane aromatics (including benzene). There are four major types of reactions which occur during reforming processes: 1) dehydrogenation of naphthenes to aromatics; 2) dehydrocyclization of paraffins to aromatics; 3) isomerization; and 4) hydrocracking. The dehydrogenation reactions are very endothermic, requiring that the hydrocarbon stream be heated between each catalyst bed. All but the hydrocracking reaction release hydrogen which can be used in the hydrotreating or hydrocracking processes. Fixed-bed or moving bed processes are utilized in a series of three to six reactors. Feedstocks to catalytic reforming processes are usually hydrotreated first to remove sulfur, nitrogen and metallic contaminants. In continuous reforming processes, catalysts can be regenerated one reactor at a time, once or twice per day, without disrupting the operation of the unit. In semi regenerative units, regeneration of all reactors can be carried out simultaneously after three to 24 months of operation by first shutting down the process.<sup>51</sup> Because the recent reformulated gasoline rules have limited the allowable amount of benzene in gasoline (Section VI.B), catalytic reforming is being used less as an octane enhancer than in past years.

Air emissions from catalytic reforming arise from the process heater gas and fugitive emissions. The catalysts used in catalytic reforming processes are usually very expensive and extra precautions are taken to ensure that catalyst is not lost. When the catalyst has lost its activity and can no longer be regenerated, the catalyst is usually sent off-site for recovery of the metals.<sup>52</sup> Subsequent air emissions from catalyst regeneration is, therefore, relatively low. Relatively small volumes of wastewater containing sulfides, ammonia, and mercaptans may be generated from the stripping tower used to remove light ends from the reactor effluent.<sup>53</sup>

### *Solvent Extraction*

Solvent extraction uses solvents to dissolve and remove aromatics from lube oil feed stocks, improving viscosity, oxidation resistance, color and gum formation. A number of different solvents are used with the two most common being furfural and phenol. Typically, feed lube stocks are contacted with the solvent in a packed tower or rotating disc contactor. Each solvent

has a different solvent-to-oil ratio and recycle ratio within the tower. Solvents are recovered from the oil stream through distillation and steam stripping in a fractionator. The stream extracted from the solvent will likely contain high concentrations of hydrogen sulfide, aromatics, naphthenes and other hydrocarbons, and is often fed to the hydrocracking unit. The water stream leaving the fractionator will likely contain some oil and solvents.<sup>54</sup>

### *Chemical Treating*

In petroleum refining, chemical treating is used to remove or change the undesirable properties associated with sulfur, nitrogen, or oxygen compound contaminants in petroleum products. Chemical treating is accomplished by either extraction or oxidation (also known as sweetening), depending upon the product. Extraction is used to remove sulfur from the very light petroleum fractions, such as propane/propylene (PP) and butane/butylene (BB). Sweetening, though, is more effective on gasoline and middle distillate products.

A typical extraction process is "Merox" extraction. Merox extraction is used to remove mercaptans (organic sulfur compounds) from PP and BB streams. PP streams may undergo amine treating before the Merox extraction to remove excess H<sub>2</sub>S which tends to fractionate with PP and interferes with the Merox process. A caustic prewash of the PP and BB removes any remaining trace H<sub>2</sub>S prior to Merox extraction.

The PP and BB streams are passed up through the trays of an extraction tower. Caustic solution flowing down the extraction tower absorbs mercaptan from the PP and BB streams. The rich caustic is then regenerated by oxidizing the mercaptans to disulfide in the presence of aqueous Merox catalyst and the lean caustic recirculated to the extraction tower. The disulfide is insoluble in the caustic and can be separated.

Oxidation or "sweetening" is used on gasoline and distillate fractions. A common oxidation process is also a Merox process that uses a solid catalyst bed. Air and a minimum amount of alkaline caustic ("mini-alky" operation) is injected into the hydrocarbon stream. As the hydrocarbon passes through the Merox catalyst bed, sulfur mercaptans are oxidized to disulfide. In the sweetening Merox process, the caustic is not regenerated. The disulfide can remain with the gasoline product, since it does not possess the objectionable odor properties of mercaptans; hence, the product has been "sweetened."<sup>55</sup>

In the extraction process, a waste oily disulfide stream leaves the separator. Air emissions arise from fugitive hydrocarbons and the process vents on the separator which may contain disulfides.<sup>56</sup>

*Dewaxing*

Dewaxing of lubricating oil base stocks is necessary to ensure that the oil will have the proper viscosity at lower ambient temperatures. Two types of dewaxing processes are used: selective hydrocracking and solvent dewaxing. In selective hydrocracking, one or two zeolite catalysts are used to selectively crack the wax paraffins. Solvent dewaxing is more prevalent. In solvent dewaxing, the oil feed is diluted with solvent to lower the viscosity, chilled until the wax is crystallized, and then filtered to remove the wax. Solvents used for the process include propane and mixtures of methyl ethyl ketone (MEK) with methyl isobutyl ketone (MIBK) or MEK with toluene. Solvent is recovered from the oil and wax through heating, two-stage flashing, followed by steam stripping. The solvent recovery stage results in solvent contaminated water which typically is sent to the wastewater treatment plant. The wax is either used as feed to the catalytic cracker or is deoiled and sold as industrial wax. Air emissions may arise from fugitive emissions of the solvents.<sup>57</sup>

*Propane Deasphalting*

Propane deasphalting produces lubricating oil base stocks by extracting asphaltenes and resins from the residuals of the vacuum distillation unit. Propane is usually used to remove asphaltenes due to its unique solvent properties. At lower temperatures (100 to 140 degrees F), paraffins are very soluble in propane and at higher temperatures (about 200 degrees F) all hydrocarbons are almost insoluble in propane. The propane deasphalting process is similar to solvent extraction in that a packed or baffled extraction tower or rotating disc contactor is used to mix the oil feed stocks with the solvent. In the tower method, four to eight volumes of propane are fed to the bottom of the tower for every volume of feed flowing down from the top of the tower. The oil, which is more soluble in the propane dissolves and flows to the top. The asphaltene and resins flow to the bottom of the tower where they are removed in a propane mix. Propane is recovered from the two streams through two-stage flash systems followed by steam stripping in which propane is condensed and removed by cooling at high pressure in the first stage and at low pressure in the second stage. The asphalt recovered can be blended with other asphalts or heavy fuels, or can be used as feed to the coker. The propane recovery stage results in propane contaminated water which typically is sent to the wastewater treatment plant. Air emissions may arise from fugitive propane emissions and process vents.<sup>58</sup>

### III.A.3. Supporting Operations

Many important refinery operations are not directly involved in the production of hydrocarbon fuels but serve in a supporting role. Some of the major supporting processes are discussed below.

#### *Wastewater Treatment*

Relatively large volumes of water are used by the petroleum refining industry. Four types of wastewater are produced: surface water runoff, cooling water, process water, and sanitary wastewater. Surface water runoff is intermittent and will contain constituents from spills to the surface, leaks in equipment and any materials that may have collected in drains. Runoff surface water also includes water coming from crude and product storage tank roof drains.

A large portion of water used in petroleum refining is used for cooling. Cooling water typically does not come into direct contact with process oil streams and therefore contains less contaminants than process wastewater. Most cooling water is recycled over and over with a bleed or blowdown stream to the wastewater treatment unit to control the concentration of contaminants and the solids content in the water. Cooling towers within the recycle loop cool the water using ambient air. (See *Storage Tanks and Cooling Towers*) Some cooling water, termed “once through,” is passed through a process unit once and is then discharged directly without treatment in the wastewater treatment plant. The water used for cooling often contains chemical additives such as chromates, phosphates, and antifouling biocides to prevent scaling of pipes and biological growth. (It should be noted, however, that many refineries no longer use chromates in cooling water as anti-fouling agents.) Although cooling water usually does not come into direct contact with oil process streams, it also may contain some oil contamination due to leaks in the process equipment.<sup>59</sup>

Water used in processing operations also accounts for a significant portion of the total wastewater. Process wastewater arises from desalting crude oil, steam stripping operations, pump gland cooling, product fractionator reflux drum drains and boiler blowdown. Because process water often comes into direct contact with oil, it is usually highly contaminated.<sup>60</sup>

Petroleum refineries typically utilize primary and secondary wastewater treatment. Primary wastewater treatment consists of the separation of oil, water and solids in two stages. During the first stage, an API separator, a corrugated plate interceptor, or other separator design is used. Wastewater moves very slowly through the separator allowing free oil to float to the surface and be skimmed off, and solids to settle to the bottom and be scraped

off to a sludge collecting hopper. The second stage utilizes physical or chemical methods to separate emulsified oils from the wastewater. Physical methods may include the use of a series of settling ponds with a long retention time, or the use of dissolved air flotation (DAF). In DAF, air is bubbled through the wastewater, and both oil and suspended solids are skimmed off the top. Chemicals, such as ferric hydroxide or aluminum hydroxide, can be used to coagulate impurities into a froth or sludge which can be more easily skimmed off the top. Some wastes associated with the primary treatment of wastewater at petroleum refineries may be considered hazardous and include: API separator sludge, primary treatment sludge, sludges from other gravitational separation techniques, float from DAF units, and wastes from settling ponds (Exhibit 13).<sup>61</sup>

After primary treatment, the wastewater can be discharged to a publicly owned treatment works or undergo secondary treatment before being discharged directly to surface waters under a National Pollution Discharge Elimination System (NPDES) permit. In secondary treatment, dissolved oil and other organic pollutants may be consumed biologically by microorganisms. Biological treatment may require the addition of oxygen through a number of different techniques, including activated sludge units, trickling filters, and rotating biological contactors. Secondary treatment generates bio-mass waste which is typically treated anaerobically, and then dewatered.<sup>62</sup>

Some refineries employ an additional stage of wastewater treatment called polishing to meet discharge limits. The polishing step can involve the use of activated carbon, anthracite coal, or sand to filter out any remaining impurities, such as biomass, silt, trace metals and other inorganic chemicals, as well as any remaining organic chemicals.<sup>63,64</sup>

Certain refinery wastewater streams are treated separately, prior to the wastewater treatment plant, to remove contaminants that would not easily be treated after mixing with other wastewater. One such waste stream is the sour water drained from distillation reflux drums. Sour water contains dissolved hydrogen sulfide and other organic sulfur compounds and ammonia which are stripped in a tower with gas or steam before being discharged to the wastewater treatment plant.<sup>65</sup>

Wastewater treatment plants are a significant source of refinery air emissions and solid wastes. Air releases arise from fugitive emissions from the numerous tanks, ponds and sewer system drains. Solid wastes are generated in the form of sludges from a number of the treatment units.

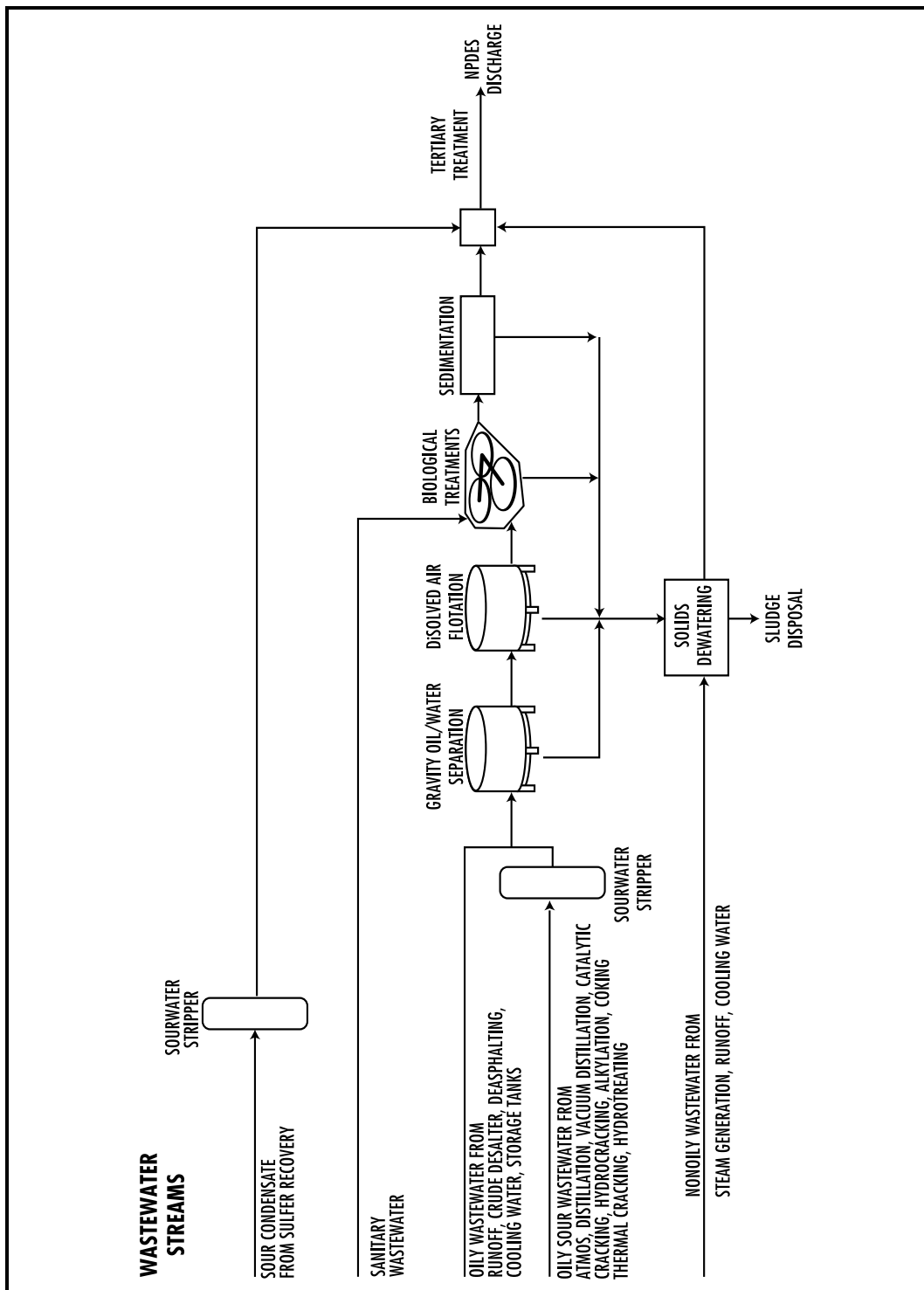

(Source: Based on U.S. EPA Office of General Enforcement, *Petroleum Refinery Enforcement Manual*, 1980.)

**Exhibit 13: Typical Refinery Wastewater Treatment System**

*Gas Treatment and Sulfur Recovery*

Sulfur is removed from a number of refinery process off-gas streams (sour gas) in order to meet the  $\text{SO}_x$  emissions limits of the CAA and to recover saleable elemental sulfur. Process off-gas streams, or sour gas, from the coker, catalytic cracking unit, hydrotreating units and hydroprocessing units can contain high concentrations of hydrogen sulfide mixed with light refinery fuel gases. Before elemental sulfur can be recovered, the fuel gases (primarily methane and ethane) need to be separated from the hydrogen sulfide. This is typically accomplished by dissolving the hydrogen sulfide in a chemical solvent. Solvents most commonly used are amines, such as diethanolamine (DEA). Dry adsorbents such as molecular sieves, activated carbon, iron sponge and zinc oxide are also used. In the amine solvent processes, DEA solution or another amine solvent is pumped to an absorption tower where the gases are contacted and hydrogen sulfide is dissolved in the solution. The fuel gases are removed for use as fuel in process furnaces in other refinery operations. The amine-hydrogen sulfide solution is then heated and steam stripped to remove the hydrogen sulfide gas.<sup>66</sup>

Current methods for removing sulfur from the hydrogen sulfide gas streams are typically a combination of two processes: the Claus Process followed by the Beaven Process, Scot Process, or the Wellman-Land Process. The Claus process consists of partial combustion of the hydrogen sulfide-rich gas stream (with one-third the stoichiometric quantity of air) and then reacting the resulting sulfur dioxide and unburned hydrogen sulfide in the presence of a bauxite catalyst to produce elemental sulfur (Exhibit 14).

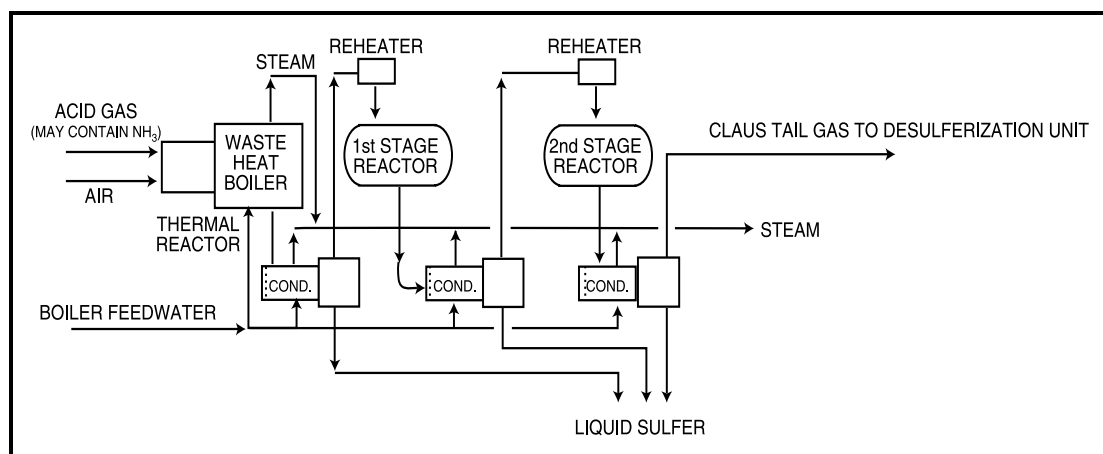

(Source: Based on U.S. EPA Office of General Enforcement, *Petroleum Refinery Enforcement Manual*, 1980.)

### Exhibit 14: Simplified Claus Sulfur Recovery Flow Diagram

Since the Claus process by itself removes only about 90 percent of the hydrogen sulfide in the gas stream, the Beaven, SCOT, or Wellman-Lord processes are often used to further recover sulfur. In the Beaven process, the hydrogen sulfide in the relatively low concentration gas stream from the Claus process can be almost completely removed by absorption in a quinone solution. The dissolved hydrogen sulfide is oxidized to form a mixture of elemental sulfur and hydro-quinone. The solution is injected with air or oxygen to oxidize the hydro-quinone back to quinone. The solution is then filtered or centrifuged to remove the sulfur and the quinone is then reused. The Beaven process is also effective in removing small amounts of sulfur dioxide, carbonyl sulfide, and carbon disulfide that are not affected by the Claus process. These compounds are first converted to hydrogen sulfide at elevated temperatures in a cobalt molybdate catalyst prior to being fed to the Beaven unit.<sup>67,68</sup> Air emissions from sulfur recovery units will consist of hydrogen sulfide, SO<sub>x</sub> and NO<sub>x</sub> in the process tail gas as well as fugitive emissions and releases from vents.

The SCOT process is also widely used for removing sulfur from the Claus tail gas. The sulphur compounds in the Claus tail gas are converted to hydrogen sulfide by heating and passing it through a cobalt-molybdenum catalyst with the addition of a reducing gas. The gas is then cooled and contacted with a solution of di-isopropanolamine (DIPA) which removes all but trace amounts of hydrogen sulfide. The sulfide-rich DIPA is sent to a stripper where hydrogen sulfide gas is removed and sent to the Claus plant. The DIPA is returned to the absorption column.

### *Additive Production*

A number of chemicals (mostly alcohols and ethers) are added to motor fuels to either improve performance or meet federal and state environmental requirements. Since the 1970s, alcohols (methanol and ethanol) and ethers have been added to gasoline to increase octane levels and reduce carbon monoxide generation in place of the lead additives which were being phased out as required by the 1970 Clean Air Act. In 1990, the more stringent Clean Air Act Amendments (see Section V.B) established minimum and maximum amounts of chemically combined oxygen in motor fuels as well as an upper limit on vapor pressure. As a result, alcohol additives have been increasingly supplemented or replaced with a number of different ethers which are better able to meet both the new oxygen requirements and the vapor pressure limits.

The most common ethers being used as additives are methyl tertiary butyl ether (MTBE), and tertiary amyl methyl ether (TAME). Many of the larger refineries manufacture their own supplies of MTBE and TAME by reacting isobutylene and/or isoamylene with methanol. Smaller refineries usually buy

their supplies from chemical manufacturers or the larger refineries. Isobutylene is obtained from a number of refinery sources including: the light naphtha from the FCCU and coking units, the by-product from steam cracking of naphtha or light hydrocarbons during the production of ethylene and propylene, catalytic dehydrogenation of isobutane, and conversion of tertiary butyl alcohol recovered as a by-product in the manufacture of propylene oxides. Several different processes are currently in use to produce MTBE and TAME from isobutylene and methanol. Most processes use a two-stage acidic ion exchange resin catalyst. The reaction is exothermic and cooling to the proper reaction temperature is critical in obtaining the optimal conversion efficiency. The process usually produces an MTBE or TAME stream and a relatively small stream of unreacted hydrocarbons and methanol. The methanol is extracted in a water wash and the resulting methanol-water mixture is distilled to recover the methanol for recycling.

### *Heat Exchanger Cleaning*

Heat exchangers are used throughout petroleum refineries to heat or cool petroleum process streams. The heat exchangers consist of bundles of pipes, tubes, plate coils, or steam coils enclosing heating or cooling water, steam, or oil to transfer heat indirectly to or from the oil process stream. The bundles are cleaned periodically to remove accumulations of scales, sludge and any oily residues. Because chromium has almost been eliminated as a cooling water additive, wastes generated from the cleaning of heat exchanger bundles no longer account for a significant portion of the hazardous wastes generated at refining facilities. The sludge generated may contain lead or chromium, although some refineries which do not produce leaded gasoline and which use non-chrome corrosion inhibitors typically do not generate sludge that contains these constituents. Oily wastewater is also generated during heat exchanger cleaning.<sup>69</sup>

### *Blowdown System*

Most refinery process units and equipment are manifolded into a collection unit, called the blowdown system. Blowdown systems provide for the safe handling and disposal of liquid and gases that are either automatically vented from the process units through pressure relief valves, or that are manually drawn from units. Recirculated process streams and cooling water streams are often manually purged to prevent the continued build up of contaminants in the stream. Part or all of the contents of equipment can also be purged to the blowdown system prior to shutdown before normal or emergency shutdowns. Blowdown systems utilize a series of flash drums and condensers to separate the blowdown into its vapor and liquid components. The liquid is typically composed of mixtures of water and hydrocarbons containing

sulfides, ammonia, and other contaminants, which are sent to the wastewater treatment plant. The gaseous component typically contains hydrocarbons, hydrogen sulfide, ammonia, mercaptans, solvents, and other constituents, and is either discharged directly to the atmosphere or is combusted in a flare. The major air emissions from blowdown systems are hydrocarbons in the case of direct discharge to the atmosphere and sulfur oxides when flared.

### *Blending*

Blending is the final operation in petroleum refining. It consists of mixing the products in various proportions to meet specifications such as vapor pressure, specific gravity, sulfur content, viscosity, octane number, cetane index, initial boiling point, and pour point. Blending can be carried out in-line or in batch blending tanks. Air emissions from blending are fugitive VOCs from blending tanks, valves, pumps and mixing operations.<sup>70</sup>

### *Storage Tanks*

Storage tanks are used throughout the refining process to store crude oil and intermediate process feeds for cooling and further processing. Finished petroleum products are also kept in storage tanks before transport off site. Storage tank bottoms are mixtures of iron rust from corrosion, sand, water, and emulsified oil and wax, which accumulate at the bottom of tanks. Liquid tank bottoms (primarily water and oil emulsions) are periodically drawn off to prevent their continued build up. Tank bottom liquids and sludge are also removed during periodic cleaning of tanks for inspection. Tank bottoms may contain amounts of tetraethyl or tetramethyl lead (although this is increasingly rare due to the phaseout of leaded products), other metals, and phenols. Solids generated from leaded gasoline storage tank bottoms are listed as a RCRA hazardous waste.<sup>71,72</sup>

Even if equipped with floating tops, storage tanks account for considerable VOC emissions at petroleum refineries. A study of petroleum refinery emissions found that the majority of tank losses occurred through tank seals on gasoline storage tanks.<sup>73</sup>

### *Cooling Towers*

Cooling towers cool heated water by circulating the water through a tower with a predetermined flow of ambient air pushed with large fans. A certain amount of water exits the system through evaporation, mist droplets and as bleed or blowdown to the wastewater treatment system. Therefore, make-up water in the range of about five percent of the circulation rate is required.<sup>74</sup>

### III.B. Raw Material Inputs and Pollution Outputs in the Production Line

Raw material input to petroleum refineries is primarily crude oil; however, petroleum refineries use and generate an enormous number of chemicals, many of which leave the facilities as discharges of air emissions, wastewater, or solid waste. Pollutants generated typically include VOCs, carbon monoxide (CO), sulfur oxides (SO<sub>x</sub>), nitrogen oxides (NO<sub>x</sub>), particulates, ammonia (NH<sub>3</sub>), hydrogen sulfide (H<sub>2</sub>S), metals, spent acids, and numerous toxic organic compounds. Exhibit 15 summarizes the main pollutant outputs for each major refinery process.

When discussing material outputs of the petroleum refining industry, it is important to note the relationship between the outputs of the industry itself and the outputs resulting from the use of refinery products. Petroleum refineries play an important role in the U.S. economy, supplying approximately 40 percent of the total energy used in the U.S. and virtually all of the energy consumed in the transportation sector. The pollutant outputs from the refining facilities, however, are modest in comparison to the pollutant outputs realized from the consumption of petroleum products by the transportation sector, electric utilities, chemical manufacturers and other industrial and commercial users.

#### *Air Emissions*

Air emissions from refineries include fugitive emissions of the volatile constituents in crude oil and its fractions, emissions from the burning of fuels in process heaters, and emissions from the various refinery processes themselves. Fugitive emissions occur throughout refineries and arise from the thousands of potential fugitive emission sources such as valves, pumps, tanks, pressure relief valves, flanges, etc. While individual leaks are typically small, the sum of all fugitive leaks at a refinery can be one of its largest emission sources. Fugitive emissions can be reduced through a number of techniques, including improved leak resistant equipment, reducing the number of tanks and other potential sources and, perhaps the most effective method, an ongoing Leak Detection and Repair (LDAR) program.

The numerous process heaters used in refineries to heat process streams or to generate steam (boilers) for heating or steam stripping, can be potential sources of SO<sub>x</sub>, NO<sub>x</sub>, CO, particulates and hydrocarbons emissions. When operating properly and when burning cleaner fuels such as refinery fuel gas, fuel oil or natural gas, these emissions are relatively low. If, however, combustion is not complete, or heaters are fired with refinery fuel pitch or residuals, emissions can be significant.<sup>75</sup>

The majority of gas streams exiting each refinery process contain varying amounts of refinery fuel gas, hydrogen sulfide and ammonia. These streams are collected and sent to the gas treatment and sulfur recovery units to recover the refinery fuel gas and sulfur. Emissions from the sulfur recovery unit typically contains some H<sub>2</sub>S, SO<sub>x</sub> and NO<sub>x</sub>. Other emissions sources from refinery processes arise from periodic regeneration of catalysts. These processes generate streams that may contain relatively high levels of carbon monoxide, particulates and VOCs. Before being discharged to the atmosphere, such off-gas streams may be treated first through a carbon monoxide boiler to burn carbon monoxide and any VOCs, and then through an electrostatic precipitator or cyclone separator to remove particulates.<sup>76</sup>

### *Wastewater*

Wastewaters consist of cooling water, process water, sanitary sewage water, and storm water. Wastewaters are treated in onsite wastewater treatment facilities and then discharged to POTWs or discharged to surface waters under NPDES permits. In addition, some facilities use underground injection of some wastewater streams. (See Wastewater Treatment in Section III.A.)

Many refineries unintentionally release, or have unintentionally released in the past, liquid hydrocarbons to ground water and surface waters. At some refineries contaminated ground water has migrate off-site and resulted in continuous “seeps” to surface waters. While the actual volume of hydrocarbons released in such a manner are relatively small, there is the potential to contaminate large volumes of ground water and surface water possibly posing a substantial risk to human health and the environment.

### *Other Wastes*

Other wastes are generated from many of the refining processes, petroleum handling operations, as well as wastewater treatment. Both hazardous and non-hazardous wastes are generated, treated and disposed. Residual refinery wastes are typically in the form of sludges, spent process catalysts, filter clay, and incinerator ash. Treatment of these wastes includes incineration, land treating off-site, land filling onsite, land filling off-site, chemical fixation, neutralization, and other treatment methods.

A significant portion of the non-petroleum product outputs of refineries is transported off-site and sold as byproducts. These outputs include sulfur, acetic acid, phosphoric acid, and recovered metals. Metals from catalysts and from the crude oil that have deposited on the catalyst during the production often are recovered by third party recovery facilities.

<b>Exhibit 15: Typical Material Outputs from Selected Petroleum Refining Processes</b>			
<b>Process</b>	<b>Air Emissions</b>	<b>Process Waste Water</b>	<b>Residual Wastes Generated</b>
Crude oil desalting	Heater stack gas (CO, SO <sub>x</sub> , NO <sub>x</sub> , hydrocarbons and particulates), fugitive emissions (hydrocarbons)	Flow=2.1 Gal/Bbl Oil, H <sub>2</sub> S, NH <sub>3</sub> , phenol, high levels of suspended solids, dissolved solids, high BOD, high temperature.	Crude oil/desalter sludge (iron rust, clay, sand, water, emulsified oil and wax, metals)
Atmospheric distillation  Vacuum Distillation	Heater stack gas (CO, SO <sub>x</sub> , NO <sub>x</sub> , hydrocarbons and particulates), vents and fugitive emissions (hydrocarbons) Steam ejector emissions (hydrocarbons), heater stack gas (CO, SO <sub>x</sub> , NO <sub>x</sub> , hydrocarbons and particulates), vents and fugitive emissions (hydrocarbons)	Flow=26.0 Gal/Bbl Oil, H <sub>2</sub> S, NH <sub>3</sub> , suspended solids, chlorides, mercaptans, phenol, elevated pH.	Typically, little or no residual waste generated.
Thermal Cracking/ Visbreaking	Heater stack gas (CO, SO <sub>x</sub> , NO <sub>x</sub> , hydrocarbons and particulates), vents and fugitive emissions (hydrocarbons).	Flow=2.0 Gal/Bbl Oil, H <sub>2</sub> S, NH <sub>3</sub> , phenol, suspended solids, high pH, BOD <sub>5</sub> , COD.	Typically, little or no residual waste generated.
Coking	Heater stack gas (CO, SO <sub>x</sub> , NO <sub>x</sub> , hydrocarbons and particulates), vents and fugitive emissions (hydrocarbons) and decoking emissions (hydrocarbons and particulates).	Flow=1.0 Gal/Bbl High pH, H <sub>2</sub> S, NH <sub>3</sub> , suspended solids, COD.	Coke dust (carbon particles and hydrocarbons)
Catalytic Cracking	Heater stack gas (CO, SO <sub>x</sub> , NO <sub>x</sub> , hydrocarbons and particulates), fugitive emissions (hydrocarbons) and catalyst regeneration (CO, NO <sub>x</sub> , SO <sub>x</sub> , and particulates)	Flow=15.0 Gal/Bbl High levels of oil, suspended solids, phenols, cyanides, H <sub>2</sub> S, NH <sub>3</sub> , high pH, BOD, COD.	Spent catalysts (metals from crude oil and hydrocarbons), spent catalyst fines from electrostatic precipitators (aluminum silicate and metals)
Catalytic Hydro-cracking	Heater stack gas (CO, SO <sub>x</sub> , NO <sub>x</sub> , hydrocarbons and particulates), fugitive emissions (hydrocarbons) and catalyst regeneration (CO, NO <sub>x</sub> , SO <sub>x</sub> , and catalyst dust).	Flow=2.0 Gal/Bbl High COD, suspended solids, H <sub>2</sub> S, relatively low levels of BOD.	Spent catalysts fines (metals from crude oil, and hydrocarbons)

Process	Air Emissions	Process Waste Water	Residual Wastes Generated
Hydrotreating/ Hydroprocessing	Heater stack gas (CO, SO <sub>x</sub> , NO <sub>x</sub> , hydrocarbons and particulates), vents and fugitive emissions (hydrocarbons) and catalyst regeneration (CO, NO <sub>x</sub> , SO <sub>x</sub> )	Flow=1.0 Gal/Bbl H <sub>2</sub> S, NH <sub>3</sub> , High pH, phenols suspended solids, BOD, COD.	Spent catalyst fines (aluminum silicate and metals).
Alkylation	Heater stack gas (CO, SO <sub>x</sub> , NO <sub>x</sub> , hydrocarbons and particulates), vents and fugitive emissions (hydrocarbons)	Low pH, suspended solids, dissolved solids, COD, H <sub>2</sub> S, spent sulfuric acid.	Neutralized alkylation sludge (sulfuric acid or calcium fluoride, hydrocarbons).
Isomerization	Heater stack gas (CO, SO <sub>x</sub> , NO <sub>x</sub> , hydrocarbons and particulates), HCl (potentially in light ends), vents and fugitive emissions (hydrocarbons)	Low pH, chloride salts, caustic wash, relatively low H <sub>2</sub> S and NH <sub>3</sub> .	Calcium chloride sludge from neutralized HCl gas.
Polymerization	H <sub>2</sub> S from caustic washing	H <sub>2</sub> S, NH <sub>3</sub> , caustic wash, mercaptans and ammonia, high pH.	Spent catalyst containing phosphoric acid.
Catalytic Reforming	Heater stack gas (CO, SO <sub>x</sub> , NO <sub>x</sub> , hydrocarbons and particulates), fugitive emissions (hydrocarbons) and catalyst regeneration (CO, NO <sub>x</sub> , SO <sub>x</sub> )	Flow=6.0 Gal/Bbl High levels oil, suspended solids, COD. Relatively low H <sub>2</sub> S.	Spent catalyst fines from electrostatic precipitators (alumina silicate and metals).
Solvent Extraction	Fugitive solvents	Oil and solvents	Little or no residual wastes generated.
Dewaxing	Fugitive solvents, heaters	Oil and solvents	Little or no residual wastes generated.
Propane Deasphalting	Heater stack gas (CO, SO <sub>x</sub> , NO <sub>x</sub> , hydrocarbons and particulates), fugitive propane	Oil and propane	Little or no residual wastes generated.
Merox treating	Vents and fugitive emissions (hydrocarbons and disulfides).	Little or no wastewater generated.	Spent Merox caustic solution, waste oil-disulfide mixture.
Wastewater treatment	Fugitive emissions (H <sub>2</sub> S, NH <sub>3</sub> , and hydrocarbons)	Not Applicable	API separator sludge (phenols, metals and oil), chemical precipitation sludge (chemical coagulants, oil), DAF floats, biological sludges (metals, oil, suspended solids), spent lime.

Process	Air Emissions	Process Waste Water	Residual Wastes Generated
Gas Treatment and Sulfur Recovery	SO <sub>x</sub> , NO <sub>x</sub> , and H <sub>2</sub> S from vent and tail gas emissions.	H <sub>2</sub> S, NH <sub>3</sub> , amines, Stretford solution.	Spent catalyst.
Blending	Fugitive emissions (hydrocarbons)	Little or no wastewater generated	Little or no residual waste generated.
Heat exchanger cleaning	Periodic fugitive emissions (hydrocarbons)	Oily wastewater generated	Heat exchanger sludge (oil, metals, and suspended solids)
Storage Tanks	Fugitive emissions (hydrocarbons)	Water drained from tanks contaminated with tank product	Tank bottom sludge (iron rust, clay, sand, water, emulsified oil and wax, metals)
Blowdown and flare	Combustion products (CO, SO <sub>x</sub> , NO <sub>x</sub> and hydrocarbons) from flares, fugitive emissions	Little or no wastewater generated	Little or no residual waste generated.

Sources: *Assessment of Atmospheric Emissions from Petroleum Refining*, Radian Corp., 1980; *Petroleum Refining Hazardous Waste Generation*, U.S. EPA, Office of Solid Waste, 1994.

### III.C. Management of Chemicals in Wastestream

The Pollution Prevention Act of 1990 (PPA) requires facilities to report information about the management of TRI chemicals in waste and efforts made to eliminate or reduce those quantities. These data have been collected annually in Section 8 of the TRI reporting Form R beginning with the 1991 reporting year. The data summarized below cover the years 1992-1995 and is meant to provide a basic understanding of the quantities of waste handled by the industry, the methods typically used to manage this waste, and recent trends in these methods. TRI waste management data can be used to assess trends in source reduction within individual industries and facilities, and for specific TRI chemicals. This information could then be used as a tool in identifying opportunities for pollution prevention compliance assistance activities.

From the yearly data presented below it is apparent that the portion of TRI wastes reported as recycled on-site has increased and the portions treated or managed through energy recovery on-site have decreased between 1992 and 1995 (projected). While the quantities reported for 1992 and 1993 are estimates of quantities already managed, the quantities reported for 1994 and 1995 are projections only. The PPA requires these projections to encourage

facilities to consider future waste generation and source reduction of those quantities as well as movement up the waste management hierarchy. Future-year estimates are not commitments that facilities reporting under TRI are required to meet.

Exhibit 16 shows that the petroleum refining industry managed about 1.6 billion pounds of production-related waste (total quantity of TRI chemicals in the waste from routine production operations) in 1993 (column B). Column C reveals that of this production-related waste, 30 percent was either transferred off-site or released to the environment. Column C is calculated by dividing the total TRI transfers and releases by the total quantity of production-related waste. In other words, about 70 percent of the industry's TRI wastes were managed on-site through recycling, energy recovery, or treatment as shown in columns E, F and G, respectively. The majority of waste that is released or transferred off-site can be divided into portions that are recycled off-site, recovered for energy off-site, or treated off-site as shown in columns H, I and J, respectively. The remaining portion of the production related wastes (4 percent), shown in column D, is either released to the environment through direct discharges to air, land, water, and underground injection, or it is disposed of off-site.

<b>Exhibit 16: Source Reduction and Recycling Activity for Petroleum Industry (SIC 2911) as Reported within TRI</b>									
A	B	C	D	On-Site			Off-Site		
Year	Quantity of Production-Related Waste (10 <sup>6</sup> lbs.) <sup>a</sup>	% Released and Transferred	% Released and Disposed <sup>c</sup> Off-site	E	F	G	H	I	J
				% Recycled	% Energy Recovery	% Treated	% Recycled	% Energy Recovery	% Treated
1992	1,476	24%	3%	10%	37%	22%	27%	<1%	<1%
1993	1,600	30%	4%	14%	36%	20%	26%	<1%	<1%
1994	1,867	---	4%	19%	37%	15%	25%	<1%	<1%
1995	1,717	---	4%	21%	32%	17%	27%	<1%	<1%

<sup>a</sup> Within this industry sector, non-production related waste < 1 percent of production related wastes for 1993.  
<sup>b</sup> Total TRI transfers and releases as reported in Sections 5 and 6 of Form R as a percentage of production related wastes.  
<sup>c</sup> Percentage of production related waste released to the environment and transferred off-site for disposal.

#### IV. CHEMICAL RELEASE AND TRANSFER PROFILE

This section is designed to provide background information on the pollutant releases that are reported by this industry. The best source of comparative pollutant release information is the Toxic Release Inventory System (TRI). Pursuant to the Emergency Planning and Community Right-to-Know Act, TRI includes self-reported facility release and transfer data for over 600 toxic chemicals. Facilities within SIC Codes 20 through 39 (manufacturing industries) that have more than 10 employees, and that are above weight-based reporting thresholds are required to report TRI on-site releases and off-site transfers. The information presented within the sector notebooks is derived from the most recently available (1993) TRI reporting year, and focuses primarily on the on-site releases reported by each sector. Because TRI requires consistent reporting regardless of sector, it is an excellent tool for drawing comparisons across industries.

Although this sector notebook does not present historical information regarding TRI chemical releases over time, please note that in general, toxic chemical releases have been declining. In fact, according to the 1993 Toxic Release Inventory Data Book, reported releases dropped by 42.7 percent between 1988 and 1993. Although on-site releases have decreased, the total amount of reported toxic waste has not declined because the amount of toxic chemicals transferred off-site has increased. Transfers have increased from 3.7 billion pounds in 1991 to 4.7 billion pounds in 1993. Better management practices have led to increases in off-site transfers of toxic chemicals for recycling. More detailed information can be obtained from EPA's annual Toxics Release Inventory Public Data Release book (which is available through the EPCRA Hotline at 800-535-0202), or directly from the Toxic Release Inventory System database (for user support call 202-260-1531).

Wherever possible, the sector notebooks present TRI data as the primary indicator of chemical release within each industrial category. TRI data provide the type, amount and media receptor of each chemical released or transferred. When other sources of pollutant release data have been obtained, these data have been included to augment the TRI information.

#### TRI Data Limitations

The reader should keep in mind the following limitations regarding TRI data. Within some sectors, the majority of facilities are not subject to TRI reporting because they are not considered manufacturing industries, or because they are below TRI reporting thresholds. Examples are the mining, dry cleaning, printing, and transportation equipment cleaning sectors. For these sectors, release information from other sources has been included.

The reader should also be aware that TRI "pounds released" data presented within the notebooks is not equivalent to a "risk" ranking for each industry. Weighting each pound of release equally does not factor in the relative toxicity of each chemical that is released. The Agency is in the process of developing an approach to assign toxicological weightings to each chemical released so that one can differentiate between pollutants with significant differences in toxicity. As a preliminary indicator of the environmental impact of the industry's most commonly released chemicals, the notebook briefly summarizes the toxicological properties of the top chemicals (by weight) reported by each industry.

## Definitions Associated with Section IV Data Tables

### General Definitions

**SIC Code** -- is the Standard Industrial Classification (SIC) is a statistical classification standard used for all establishment-based Federal economic statistics. The SIC codes facilitate comparisons between facility and industry data.

**TRI Facilities** -- are manufacturing facilities that have 10 or more full-time employees and are above established chemical throughput thresholds. Manufacturing facilities are defined as facilities in Standard Industrial Classification primary codes 20 to 39. Facilities must submit estimates for all chemicals that are on the EPA's defined list and are above throughput thresholds.

### Data Table Column Heading Definitions

The following definitions are based upon standard definitions developed by EPA's Toxic Release Inventory Program. The categories below represent the possible pollutant destinations that can be reported.

**RELEASES** -- are an on-site discharge of a toxic chemical to the environment. This includes emissions to the air, discharges to bodies of water, releases at the facility to land, as well as contained disposal into underground injection wells.

**Releases to Air (Point and Fugitive Air Emissions)** -- Include all air emissions from industry activity. Point emission occur through confined air streams as found in stacks, ducts, or pipes. Fugitive emissions include losses from equipment leaks, or evaporative losses from impoundments, spills, or leaks.

**Releases to Water (Surface Water Discharges)** -- encompass any releases going directly to streams, rivers, lakes, oceans, or other bodies of water. Any estimates for stormwater runoff and non-point losses must also be included.

**Releases to Land** -- includes disposal of toxic chemicals in waste to on-site landfills, land treated or incorporation into soil, surface impoundments, spills, leaks, or waste piles. These activities must occur within the facility's boundaries for inclusion in this category.

**Underground Injection** -- is a contained release of a fluid into a subsurface well for the purpose of waste disposal.

**TRANSFERS** -- is a transfer of toxic chemicals in wastes to a facility that is geographically or physically separate from the facility reporting under TRI. The quantities reported represent a movement of the chemical away from the reporting facility. Except for off-site transfers for disposal, these quantities do not necessarily represent entry of the chemical into the environment.

**Transfers to POTWs** -- are wastewaters transferred through pipes or sewers to a publicly owned treatments works (POTW). Treatment and chemical removal depend on the chemical's nature and treatment methods used. Chemicals not treated or destroyed by the POTW are generally released to surface waters or land filled within the sludge.

**Transfers to Recycling** -- are sent off-site for the purposes of regenerating or recovering still valuable materials. Once these chemicals have been recycled, they may be returned to the originating facility or sold commercially.

**Transfers to Energy Recovery** -- are wastes combusted off-site in industrial furnaces for energy recovery. Treatment of a chemical by incineration is not considered to be energy recovery.

**Transfers to Treatment** -- are wastes moved off-site for either neutralization, incineration, biological destruction, or physical separation. In some cases, the chemicals are not destroyed but prepared for further waste management.

**Transfers to Disposal** -- are wastes taken to another facility for disposal generally as a release to land or as an injection underground.

#### IV.A. EPA Toxic Release Inventory for the Petroleum Refining Industry

The amount of TRI chemicals generated by the petroleum refining industry provides a gross profile of the types and relative amounts of toxic chemical outputs from refining processes. Additional information, which can be related back to possible compliance requirements, is available from the distribution of chemical releases across specific media within the environment. The TRI data requires filers to list releases to air, water, and land separately. The distribution across media can also be compared to the profile of other industry sectors.

The petroleum refining industry releases 75 percent of its total TRI poundage to the air, 24 percent to the water (including 20 percent to underground injection and 4 percent to surface waters), and 1 percent to the land. This release profile differs from other TRI industries which average approximately 59 percent to air, 30 percent to water, and 10 percent to land. Examining the petroleum refining industry's TRI reported toxic chemical releases highlights the likely origins of the large air releases for the industry (Exhibit 16).

According to TRI data, in 1993 the petroleum refining industry released (discharged to the air, water, or land without treatment) and transferred (shipped off-site) a total of 482 million pounds of pollutants, made up of 103 different chemicals. This represents about 11 percent of the total pounds of TRI chemicals released and transferred by all manufacturers that year. In comparison, the chemical industry (SIC 28) produced 2.5 billion pounds that year, accounting for 33 percent of all releases and transfers.

Overall, the petroleum refining industry's releases declined between 1988 and 1993. Between 1991 and 1993 the decrease in releases was 6.7 percent compared to the average for all industries of 18 percent. In the same period, however, transfers were reported to increase 65 percent which is higher than the average increase in transfers of 25 percent for all manufacturing industries. A large portion of the increases were in the form of transfers to recycling. Spent sulfuric acid generated in the alkylation process makes up about half of all transfers of TRI listed chemicals off-site. At the facility level, the industry reported a level of pollution prevention activities of 42 percent of all refineries which is slightly higher than the overall average of about 35 percent of TRI reporting facilities.

Comparisons of the reported pounds released or transferred per facility demonstrate that the petroleum refining industry is far above average in its pollutant releases and transfers per facility when compared to other TRI industries. Of the twenty manufacturing SIC codes listed in the TRI database, the mean amount of pollutant release per facility (including petroleum

refining) was approximately 120,000 pounds. The TRI releases of the average petroleum refining facility (SIC 2911) were 404,000 pounds, making the industry 3.4 times higher in per facility releases than for other industries. For transfers, the mean of petroleum refining facilities was about 13 times as much that of all TRI manufacturing facilities (202,000 pounds transferred off-site per facility compared to 2,626,000 per refinery). These high releases and transfers per facility reflect the large volumes of material processed at a relatively small number of facilities.

Of the top ten most frequently reported toxic chemicals on the TRI list, the prevalence of volatile chemicals explains the air intensive toxic chemical loading of the refining industry. Nine of the ten most commonly reported toxic chemicals are highly volatile. Seven of the ten are aromatic hydrocarbons (benzene, toluene, ethylbenzene, xylene, cyclohexane, 1,2,4-trimethylbenzene and ethylbenze). Aromatic hydrocarbons are highly volatile compounds and make up a portion of both crude oil and many finished petroleum products. Ammonia, the ninth most commonly reported toxic chemical, is also released and transferred from petroleum refineries in large quantities. Ammonia may be found in high concentrations in process water streams from steam distillation processes and in refinery sour gas. The primary means of release to the environment is through underground injection of wastewater and emissions to air. Gasoline blending additives (i.e., methanol, ethanol, and MTBE) and chemical feedstocks (propylene, ethylene and naphthalene) are also commonly reported to TRI. Additives and chemical feedstocks are, for the most part, released as air emissions due to their high volatility. A significant portion of the remaining chemicals of the reported TRI toxic chemicals are metals compounds, which are typically transferred off-site for recovery or as a component of hazardous wastes. Although it is not the most frequently reported toxic chemical released or transferred, sulfuric acid is, by far, generated in the largest quantities. Spent sulfuric acid is primarily generated during the alkylation process. The acid is typically transferred off-site for regeneration.

**Exhibit 17: 1993 Releases for Petroleum Refining Facilities in TRI, by Number of Facilities Reporting**  
**(Releases reported in pounds/year)**

CHEMICAL NAME	# REPORTING CHEMICAL	FUGITIVE AIR	POINT AIR	WATER DISCHARGES	UNDERGROUND INJECTION	LAND DISPOSAL	TOTAL RELEASES	AVG. RELEASES PER FACILITY
BENZENE	153	3,033,472	1,216,081	7,888	66,782	19,639	4,343,862	28,391
TOLUENE	146	6,447,238	2,525,056	5,106	24,233	48,271	9,049,904	61,986
ETHYLBENZENE	139	945,272	418,624	2,582	453	19,175	1,386,106	9,972
XYLENE (MIXED ISOMERS)	136	3,631,186	1,454,332	5,917	7,163	79,188	5,177,786	38,072
CYCLOHEXANE	125	973,249	478,215	3,447	297	3,587	1,458,795	11,670
1,2,4-TRIMETHYLBENZENE	116	641,879	238,163	2,164	989	5,821	889,016	7,664
SULFURIC ACID	108	5,729	1,143,906	0	0	7,586	1,157,221	10,715
PROPYLENE	106	3,508,496	1,139,819	4,615	0	0	4,652,930	43,896
AMMONIA	103	1,856,861	4,858,416	2,321,031	12,385,400	90,393	21,512,101	208,855
ETHYLENE	91	1,182,544	453,633	4,504	0	0	1,640,681	18,029
NAPHTHALENE	76	349,850	49,857	7,401	0	9,611	416,719	5,483
CHLORINE	68	43,986	97,543	8,227	0	1,180	150,936	2,220
METHYL TERT-BUTYLETHER	66	475,499	1,837,776	59,032	634	152	2,373,093	35,956
1,3-BUTADIENE	57	192,147	102,785	4,547	0	10	299,489	5,254
METHANOL	56	329,073	210,415	33,400	21,319	275	594,482	10,616
HYDROGEN FLUORIDE	52	134,710	337,003	0	0	46	471,759	9,072
CUMENE	48	478,463	66,099	244	62	282	545,150	11,357
PHENOL	48	13,312	131,318	13,748	260,000	916	419,294	8,735
DIETHANOLAMINE	44	58,746	280	58,617	284	301	118,228	2,687
PHOSPHORIC ACID	44	1,091	10	0	0	100,250	101,351	2,303
MOLYBDENUM TRIOXIDE	43	212	358	191	0	67	828	19
1,1,1-TRICHLOROETHANE	38	164,200	513	271	0	250	165,234	4,348
NICKEL COMPOUNDS	33	1,361	10,984	4,593	0	17,010	33,948	1,029
HYDROCHLORIC ACID	29	6,430	140,367	0	0	5,479	152,276	5,251
ZINC COMPOUNDS	28	4,656	8,332	20,298	0	17,992	51,278	1,831
LEAD COMPOUNDS	25	1,627	4,466	2,060	115	4,862	13,130	525
CRESOL (MIXED ISOMERS)	21	17,333	5,160	410	110,000	245	133,148	6,340
COBALT COMPOUNDS	19	26	159	1,230	0	2,164	3,579	188
CHROMIUM COMPOUNDS	18	15,331	14,055	5,046	0	91,538	125,970	6,998
ETHYLENE GLYCOL	17	6,340	21,451	192	12,137	242	40,362	2,374
CARBON TETRACHLORIDE	16	20,175	468	90	0	0	20,733	1,296
O-XYLENE	16	224,674	98,181	423	5	1,023	324,306	20,269
P-XYLENE	16	244,792	282,361	392	5	563	528,113	33,007
TETRACHLOROETHYLENE	16	21,122	303	0	0	0	21,425	1,339
METHYL ETHYL KETONE	15	4,349,330	250,384	2,782	36,000	485	4,638,981	309,265
M-XYLENE	14	297,605	55,255	566	5	1,180	354,611	25,329
NICKEL	14	315	2,724	5,690	0	3,477	12,206	872
1,2-DICHLOROETHANE	13	11,416	42	5	16	2	11,481	883
MANGANESE COMPOUNDS	12	1	2,805	6,207	0	63,000	72,013	6,001
CHROMIUM	11	2,926	12,971	2,622	0	16,847	35,366	3,215
LEAD	11	122	273	200	0	9,901	10,496	954
ANTHRACENE	10	5,590	235	147	0	1,530	7,502	750
COPPER COMPOUNDS	10	63	1,750	925	0	2,515	5,253	525
GLYCOL ETHERS	10	752	57	5	0	254	1,068	107
2-METHOXYETHANOL	10	3,073	499	0	0	0	3,572	357
BIPHENYL	8	14,005	240	157	0	0	14,402	1,800
ANTIMONY COMPOUNDS	7	145	5,264	8,667	0	4,020	18,096	2,585
1,2-DIBROMOETHANE	7	282	16	0	16	4	318	45
ACETONE	6	3,897	2,946	1,400	0	4	8,247	1,375
BARIUM	6	5	5	0	0	1,966	1,976	329
COPPER	6	12	1,305	402	0	0	1,719	287

September 1995

51

SIC 2911

Sector Notebook Project

Petroleum Refining

**Exhibit 17 (cont.): 1993 Releases for Petroleum Refining Facilities in TRI, by Number of Facilities Reporting  
(Releases reported in pounds/year)**

CHEMICAL NAME	# REPORTING CHEMICAL	FUGITIVE AIR	POINT AIR	WATER DISCHARGES	UNDERGROUN D INJECTION	LAND DISPOSAL	TOTAL RELEASES	AVG. RELEASES PER FACILITY
DICHLORODIFLUOROMETHANE	6	195,100	0	0	0	0	195,100	32,517
STYRENE	6	150,906	3,780	270	0	0	154,956	25,826
COBALT	5	7	0	0	0	443	450	90
TERT-BUTYL ALCOHOL	5	20,176	68,344	10	557	0	89,087	17,817
ARSENIC	4	5	5	0	0	319	329	82
BARIUM COMPOUNDS	4	0	1,700	1,300	0	8,700	11,700	2,925
CARBON DISULFIDE	4	5	0	0	0	3	8	2
AMMONIUM SULFATE	3	16	250	2	0	4	272	91
ASBESTOS (FRIABLE)	3	0	0	0	0	250	250	83
CADMIUM	3	4	27	0	0	33	64	21
CHLOROENZENE	3	225	17	0	0	0	242	81
DICHLOROMETHANE	3	4,099	0	34	0	0	4,133	1,378
HYDROGEN CYANIDE	3	0	74,812	260	0	0	75,072	25,024
MANGANESE	3	0	1,798	15,000	0	0	16,798	5,599
METHYL ISOBUTYL KETONE	3	16,544	5	0	0	0	16,549	5,516
N-BUTYL ALCOHOL	3	10	0	0	0	0	10	3
ZINC (FUMEOR DUST)	3	0	94	0	0	0	94	31
2,4-DIMETHYLPHENOL	3	47	0	2	0	0	49	16
ALUMINUM OXIDE	2	0	0	0	0	0	0	0
ANTIMONY	2	0	0	0	0	37	37	19
ARSENIC COMPOUNDS	2	0	8	0	0	0	8	4
BERYLLIUM	2	2	0	0	0	87	89	45
BUTYL BENZYL PHTHALATE	2	0	0	0	0	0	0	0
MERCURY COMPOUNDS	2	5	279	0	0	0	284	142
SELENIUM	2	0	0	0	0	256	256	128
SILVER	2	1,800	0	0	0	750	2,550	1,275
1,2-DICHLOROPROPANE	2	610	0	210	0	5	825	413
AMMONIUM NITRATE	1	0	0	0	0	0	0	0
BENZIDINE	1	16	0	0	0	0	16	16
BERYLLIUM COMPOUNDS	1	0	1	0	0	0	1	1
BROMOCHLORODIFLUOROMETH	1	0	0	0	0	0	0	0
BROMOTRIFLUOROMETHANE	1	0	0	0	0	0	0	0
CADMIUM COMPOUNDS	1	0	0	0	0	0	0	0
CARBONYL SULFIDE	1	0	0	0	0	0	0	0
CHLORINE DIOXIDE	1	0	0	0	0	0	0	0
CHLOROFORM	1	0	0	0	0	0	0	0
DIBENZOFURAN	1	0	0	0	0	0	0	0
ETHYLENE OXIDE	1	150,000	400	0	0	0	150,400	150,400
FORMALDEHYDE	1	0	12,080	0	0	0	12,080	12,080
HYDRAZINE	1	14	0	0	0	0	14	14
ISOPROPYL ALCOHOL	1	0	0	0	0	0	0	0
MERCURY	1	0	0	0	0	5	5	5
METHYL METHACRYLATE	1	0	0	0	0	0	0	0
NITRIC ACID	1	140	230	0	0	0	370	370
PHOSPHORUS	1	0	0	0	0	0	0	0
SELENIUM COMPOUNDS	1	0	41	0	0	0	41	41
SILVER COMPOUNDS	1	0	0	730	0	0	730	730
TOLUENE-2,4-	1	0	0	0	0	0	0	0
VANADIUM (FUMEOR DUST)	1	0	0	0	0	14,000	14,000	14,000
VINYL ACETATE	1	250	0	0	0	0	250	250
1,1,2-TRICHLOROETHANE	1	3	1	0	0	0	4	4
<b>TOTAL</b>	<b>159</b>	<b>30,260,605</b>	<b>17,847,132</b>	<b>2,625,259</b>	<b>12,926,472</b>	<b>658,195</b>	<b>64,317,663</b>	<b>404,514</b>

September 1995

52

SIC 2911

Sector Notebook Project

Petroleum Refining

**Exhibit 18: 1993 Transfers for Petroleum Refining Facilities in TRI, by Number of Facilities Reporting  
(Transfers reported in pounds/year)**

CHEMICAL NAME	# REPORTING CHEMICAL	POTW DISCHARGES	DISPOSAL	RECYCLING	TREATMENT	ENERGY RECOVERY	TOTAL TRANSFERS	AVG. TRANSFERS PER FACILITY
BENZENE	153	250,617	14,112	5,994	37,509	5,557	313,789	1,638
TOLUENE	146	257,200	40,349	18,287	32,206	64,853	412,895	2,828
ETHYLBENZENE	139	33,348	21,755	2,558	7,905	15,534	81,100	583
XYLENE (MIXED ISOMERS)	136	208,988	47,665	7,478	38,529	78,314	380,974	2,801
CYCLOHEXANE	125	5,611	2,758	1,978	2,239	2,237	14,823	119
1,2,4-TRIMETHYLBENZENE	116	4,398	12,421	684	5,911	25,040	48,454	418
SULFURIC ACID	108	0	15,295	405,530,710	188	10	405,546,203	3,755,057
PROPYLENE	106	0	479	0	3	0	482	5
AMMONIA	103	1,641,533	42,827	37	561	259	1,685,217	16,361
ETHYLENE	91	0	28	0	2	0	30	0
NAPHTHALENE	76	2,637	18,083	416	4,677	6,540	32,353	426
CHLORINE	68	382	0	0	0	0	382	6
METHYL TERT-BUTYL	66	89,724	130	450	45	281	90,630	1,373
1,3-BUTADIENE	57	0	14	0	2	0	16	0
METHANOL	56	486,343	442	84	673	422	487,964	8,714
HYDROGEN FLUORIDE	52	0	1,260	0	2,576	0	3,836	74
CUMENE	48	219	2,391	21	2,242	461	5,334	111
PHENOL	48	928,168	26,548	30,740	606	23	986,085	20,543
DIETHANOLAMINE	44	248,408	300	220,092	4	0	468,804	10,655
PHOSPHORIC ACID	44	0	742,510	48,000	76,034	0	866,544	19,694
MOLYBDENUM TRIOXIDE	43	0	267,672	1,906,057	23,541	0	2,197,270	51,099
1,1,1-TRICHLOROETHANE	38	250	4	48,429	1,210	7,300	57,193	1,505
NICKEL COMPOUNDS	33	1,049	340,304	750,224	13,636	136	1,105,349	33,495
HYDROCHLORIC ACID	29	0	0	0	0	0	0	0
ZINC COMPOUNDS	28	27,635	62,076	178,276	16,327	592	284,906	10,175
LEAD COMPOUNDS	25	1,105	27,074	6,184	18,123	481	52,967	2,119
CRESOL (MIXED ISOMERS)	21	44,831	18,066	130,054	1,403	117	194,471	9,261
COBALT COMPOUNDS	19	0	61,066	334,690	7,510	1	403,267	21,225
CHROMIUM COMPOUNDS	18	6,070	46,559	13,085	8,421	124	74,259	4,126
ETHYLENE GLYCOL	17	58,000	0	120,230	3,806	19	182,055	10,709
CARBON TETRACHLORIDE	16	0	3	14	27	6	50	3
O-XYLENE	16	3,502	3,084	939	85	1,000	8,610	538
P-XYLENE	16	1,365	3,006	889	331	360	5,951	372
TETRACHLOROETHYLENE	16	0	0	494	0	0	494	31
METHYL ETHYL KETONE	15	39	375	1,760	6,643	5,300	14,117	941
M-XYLENE	14	3,013	4,547	301	358	310	8,529	609
NICKEL	14	340	32,758	89,963	3,904	45	127,010	9,072
1,2-DICHLOROETHANE	13	1	253	0	0	0	254	20
MANGANESE COMPOUNDS	12	0	8,210	15,234	31,000	74	54,518	4,543
CHROMIUM	11	7,302	4,729	53,149	15,234	46	80,460	7,315
LEAD	11	397	17,265	2,524	895	83	21,164	1,924
ANTHRACENE	10	0	2,883	242	405	193	3,723	372
COPPER COMPOUNDS	10	3,004	5,531	117,219	2,025	25	127,804	12,780
GLYCOL ETHERS	10	0	0	4,104	0	0	4,104	410
2-METHOXYETHANOL	10	0	0	0	0	0	0	0
BIPHENYL	8	0	216	0	157	966	1,339	167
ANTIMONY COMPOUNDS	7	780	15,129	4,805	10,807	0	31,521	4,503
1,2-DIBROMOETHANE	7	0	0	0	5	5	10	1
ACETONE	6	120,229	0	0	0	0	120,229	20,038
BARIUM	6	2,136	26,610	3,778	256	90	32,870	5,478
COPPER	6	21	70,214	7,123	1,364	0	78,722	13,120
DICHLORODIFLUOROMETHANE	6	0	0	65	0	0	65	11
STYRENE	6	0	11	0	1	1	13	2

September 1995

53

SIC 2911

Sector Notebook Project

Petroleum Refining

**Exhibit 18 (cont.): 1993 Transfers for Petroleum Refining Facilities in TRI, by Number of Facilities Reporting  
(Transfers reported in pounds/year)**

CHEMICAL NAME	# REPORTING CHEMICAL	POTW DISCHARGES	DISPOSAL	RECYCLING	TREATMENT	ENERGY RECOVERY	TOTAL TRANSFERS	AVG. TRANSFERS PER FACILITY
COBALT	5	0	624	4,949	61	0	5,634	1,127
TERT-BUTYL ALCOHOL	5	0	0	0	0	22	22	4
ARSENIC	4	1	383	0	252	3	639	160
BARIUM COMPOUNDS	4	0	1,325	102	2,547	0	3,974	994
CARBON DISULFIDE	4	0	0	0	0	0	0	0
AMMONIUM SULFATE (SOLUTION)	3	99,000	2	0	0	0	99,002	33,001
ASBESTOS (FRIABLE)	3	0	278,521	0	0	0	278,521	92,840
CADMIUM	3	0	37	0	1	0	38	13
CHLOROBENZENE	3	0	0	0	0	0	0	0
DICHLOROMETHANE	3	0	0	0	0	0	0	0
HYDROGEN CYANIDE	3	0	0	0	0	0	0	0
MANGANESE	3	610	0	19,000	0	0	19,610	6,537
METHYL ISOBUTYL KETONE	3	0	299	750	0	0	1,049	350
N-BUTYL ALCOHOL	3	1,600	0	0	0	0	1,600	533
ZINC (FUME OR DUST)	3	0	13,794	0	1,756	0	15,550	5,183
2,4-DIMETHYLPHENOL	3	5,445	0	18,411	4	1	23,861	7,954
ALUMINUM OXIDE(FIBROUSFORM)	2	0	340,174	93,503	0	0	433,677	216,839
ANTIMONY	2	0	4,087	0	3	8	4,098	2,049
ARSENIC COMPOUNDS	2	0	11	2	0	0	13	7
BERYLLIUM	2	0	9	0	0	0	9	5
BUTYL BENZYL PHTHALATE	2	0	0	0	0	0	0	0
MERCURY COMPOUNDS	2	0	39	0	7	0	46	23
SELENIUM	2	0	83	0	274	0	357	179
SILVER	2	0	752	0	54	0	806	403
1,2-DICHLOROPROPANE	2	2	0	0	1	0	3	2
AMMONIUM NITRATE(SOLUTION)	1	0	0	0	0	0	0	0
BENZIDINE	1	0	0	0	0	0	0	0
BERYLLIUM COMPOUNDS	1	0	0	0	0	0	0	0
BROMOCHLORODIFLUOROMETHANE	1	0	0	0	0	0	0	0
BROMOTRIFLUOROMETHANE	1	0	0	0	0	0	0	0
CADMIUM COMPOUNDS	1	0	4	0	0	0	4	4
CARBONYL SULFIDE	1	0	0	0	0	0	0	0
CHLORINE DIOXIDE	1	0	0	0	0	0	0	0
CHLOROFORM	1	0	0	0	0	0	0	0
DIBENZOFURAN	1	0	0	0	0	0	0	0
ETHYLENE OXIDE	1	0	0	0	0	0	0	0
FORMALDEHYDE	1	0	0	0	0	0	0	0
HYDRAZINE	1	0	0	0	0	0	0	0
ISOPROPYL	1	0	0	0	0	0	0	0
MERCURY	1	0	5	0	0	0	5	5
METHYL METHACRYLATE	1	0	0	0	0	0	0	0
NITRIC ACID	1	0	0	0	0	0	0	0
PHOSPHORUS (YELLOWORWHITE)	1	0	361	0	0	0	361	361
SELENIUM COMPOUNDS	1	0	7	0	0	0	7	7
SILVER COMPOUNDS	1	0	0	0	0	0	0	0
TOLUENE-2,4-DIISOCYANATE	1	0	0	0	0	0	0	0
VANADIUM (FUME OR DUST)	1	0	6,400	0	1,080	0	7,480	7,480
VINYL ACETATE	1	0	0	0	0	0	0	0
1,1,2-TRICHLOROETHANE	1	0	0	0	0	0	0	0
<b>TOTAL</b>	<b>159</b>	<b>4,482,131</b>	<b>2,653,929</b>	<b>40,979,407</b>	<b>385,426</b>	<b>216,839</b>	<b>417,532,403</b>	<b>2,625,990</b>

September 1995

54

SIC 2911

Sector Notebook Project

Petroleum Refining

The TRI database contains a detailed compilation of self-reported, facility-specific chemical releases. The top reporting facilities for this sector are listed below (Exhibit 19). Facilities that have reported only the SIC codes covered under this notebook appear on the first list. Exhibit 20 contains additional facilities that have reported the SIC code covered within this report, and one or more SIC codes that are not within the scope of this notebook. Therefore, the second list includes facilities that conduct multiple operations -- some that are under the scope of this notebook, and some that are not. Currently, the facility-level data do not allow pollutant releases to be broken apart by industrial process.

<b>Exhibit 19: Top 10 TRI Releasing Petroleum Refineries<sup>b</sup></b>		
<b>Rank</b>	<b>Facility</b>	<b>Total TRI Releases in Pounds</b>
1	Amoco Oil Co. - Texas City, TX	13,196,734
2	Mobil Oil - Beaumont, TX	4,312,079
3	Chevron - Port Arthur, TX	2,513,247
4	BP Oil Co. Alliance Refinery - Belle Chasse, LA	1,992,942
5	Coastal Refining - Corpus Christi TX	1,827,682
6	Phillips P. R. Core Inc. - Guayama PR	1,806,163
7	Hess Oil St. Croix Refinery - Kingshill VI	1,720,814
8	Sun Refining & Marketing Co. - Tulsa, OK	1,555,245
9	Koch Refining Co. - Rosemount, MN	1,395,612
10	Koch Refining Co. - Corpus Christi TX	1,329,136
Source: U.S. EPA, Toxics Release Inventory Database, 1993.		

---

<sup>b</sup> Being included in this list does not mean that the release is associated with non-compliance with environmental laws.

---

**Exhibit 20: Top 10 TRI Releasing Facilities Reporting Petroleum Refining  
SIC Codes to TRI<sup>c</sup>**

<b>Rank</b>	<b>SIC Codes Reported in TRI</b>	<b>Facility</b>	<b>Total TRI Releases in Pounds</b>
1	2911	Amoco Oil Co. Texas City Refinery - Texas City, TX	13,196,734
2	2911, 2869, 2865, 2821	Shell Oil Co., - Deer Park, TX	4,542,726
3	2911	Mobil Oil Beaumont Refinery - Beaumont, TX	4,312,079
4	2911	Chevron USA Products, Port Arthur Refinery - Port Arthur, TX	2,513,247
5	2911, 2869, 2992	Lyondell-Citgo Refining Co. Ltd. - Houston, TX	2,340,426
6	2911, 2819, 2869	Citgo Petroleum Corp. - Lake Charles, LA	2,116,136
7	2911	BP Oil Co. Alliance Refinery - Belle Chasse, LA	1,992,942
8	2911, 2869, 2873	Chevron Products Do. Pascagoula Refinery - Pascagoula, MS	1,922,457
9	2911	Coastal Refining & Marketing Inc. - Corpus Christi, TX	1,827,682
10	2911	Phillips P.R. Core Inc. Phillipa Paraxylene Inc. - Guayama, PR	1,806,163

Source: U.S. EPA, Toxics Release Inventory Database, 1993.

#### IV.B. Summary of Selected Chemicals Released

The following is a synopsis of current scientific toxicity and fate information for the top chemicals (by weight) that facilities within this sector self-reported as released to the environment based upon 1993 TRI data. Because this section is based upon self-reported release data, it does not attempt to provide information on management practices employed by the sector to reduce the release of these chemicals. Information regarding pollutant release reductions over time may be available from EPA's TRI and 33/50 programs, or directly from the industrial trade associations that are listed in Section IX of this document. Since these descriptions are cursory, please consult the sources referenced below for a more detailed description of both the chemicals described in this section, and the chemicals that appear on the full list of TRI chemicals appearing in Section IV.A.

The brief descriptions provided below were taken from the *1993 Toxics Release Inventory Public Data Release* (EPA, 1994), the Hazardous Substances Data Bank (HSDB), and the Integrated Risk Information System

---

<sup>c</sup> Being included on this list does not mean that the release is associated with non-compliance with environmental laws.

---

(IRIS), both accessed via TOXNET<sup>d</sup>. The information contained below is based upon exposure assumptions that have been conducted using standard scientific procedures. The effects listed below must be taken in context of these exposure assumptions that are more fully explained within the full chemical profiles in HSDB.

Ammonia (CAS: 7664-41-7)

**Sources.** Ammonia is formed from the nitrogen bearing components of crude oil and can be found throughout petroleum refineries in both the gaseous and aqueous forms. Gaseous ammonia often leaves distillation, cracking and treating processes mixed with the sour gas or acid gas along with refinery fuel gases and hydrogen sulfide. Aqueous ammonia is present in the sourwater generated in the vacuum distillation unit and steam strippers or fractionators. Some release sources include, fugitive emissions, sour gas stripper, sulfur unit and wastewater discharges.

**Toxicity.** Anhydrous ammonia is irritating to the skin, eyes, nose, throat, and upper respiratory system.

Ecologically, ammonia is a source of nitrogen (an essential element for aquatic plant growth), and may therefore contribute to eutrophication of standing or slow-moving surface water, particularly in nitrogen-limited waters such as the Chesapeake Bay. In addition, aqueous ammonia is moderately toxic to aquatic organisms.

**Carcinogenicity.** There is currently no evidence to suggest that this chemical is carcinogenic.

**Environmental Fate.** Ammonia combines with sulfate ions in the atmosphere and is washed out by rainfall, resulting in rapid return of ammonia to the soil and surface waters. Ammonia is a central compound in the

---

<sup>d</sup> TOXNET is a computer system run by the National Library of Medicine that includes a number of toxicological databases managed by EPA, National Cancer Institute, and the National Institute for Occupational Safety and Health. For more information on TOXNET, contact the TOXNET help line at 800-231-3766. Databases included in TOXNET are: CCRIS (Chemical Carcinogenesis Research Information System), DART (Developmental and Reproductive Toxicity Database), DBIR (Directory of Biotechnology Information Resources), EMICBACK (Environmental Mutagen Information Center Backfile), GENE-TOX (Genetic Toxicology), HSDB (Hazardous Substances Data Bank), IRIS (Integrated Risk Information System), RTECS (Registry of Toxic Effects of Chemical Substances), and TRI (Toxic Chemical Release Inventory). HSDB contains chemical-specific information on manufacturing and use, chemical and physical properties, safety and handling, toxicity and biomedical effects, pharmacology, environmental fate and exposure potential, exposure standards and regulations, monitoring and analysis methods, and additional references.

---

environmental cycling of nitrogen. Ammonia in lakes, rivers, and streams is converted to nitrate.

**Physical Properties.** Ammonia is a corrosive and severely irritating gas with a pungent odor.

Toluene (CAS: 108-88-3)

**Sources.** Toluene is a component of crude oil and is therefore present in many refining operations. Toluene is also produced during catalytic reforming and is sold as one of the large volume aromatics used as feedstocks in chemical manufacturing. Its volatile nature makes fugitive emissions its largest release source. Point air sources may arise during the process of separating toluene from other aromatics and from solvent dewaxing operations where toluene is often used as the solvent..

**Toxicity.** Inhalation or ingestion of toluene can cause headaches, confusion, weakness, and memory loss. Toluene may also affect the way the kidneys and liver function.

Reactions of toluene (see environmental fate) in the atmosphere contribute to the formation of ozone in the lower atmosphere. Ozone can affect the respiratory system, especially in sensitive individuals such as asthma or allergy sufferers.

Some studies have shown that unborn animals were harmed when high levels of toluene were inhaled by their mothers, although the same effects were not seen when the mothers were fed large quantities of toluene. Note that these results may reflect similar difficulties in humans.

**Carcinogenicity.** There is currently no evidence to suggest that this chemical is carcinogenic.

**Environmental Fate.** A portion of releases of toluene to land and water will evaporate. Toluene may also be degraded by microorganisms. Once volatilized, toluene in the lower atmosphere will react with other atmospheric components contributing to the formation of ground-level ozone and other air pollutants.

**Physical Properties.** Toluene is a volatile organic chemical.

Xylenes (Mixed Isomers) (CAS: 1330-20-7)

**Sources.** Xylene isomers are a component of crude oil and are therefore present in many refining operations. Xylenes are also produced during catalytic reforming and are sold as one of the large volume aromatics used as feedstocks in chemical manufacturing. Xylene's volatile nature makes fugitive emissions the largest release source. Point air sources may arise during the process of separating xylene from other aromatics.

**Toxicity.** Xylenes are rapidly absorbed into the body after inhalation, ingestion, or skin contact. Short-term exposure of humans to high levels of xylene can cause irritation of the skin, eyes, nose, and throat, difficulty in breathing, impaired lung function, impaired memory, and possible changes in the liver and kidneys. Both short- and long-term exposure to high concentrations can cause effects such as headaches, dizziness, confusion, and lack of muscle coordination. Reactions of xylene (see environmental fate) in the atmosphere contribute to the formation of ozone in the lower atmosphere. Ozone can affect the respiratory system, especially in sensitive individuals such as asthma or allergy sufferers.

**Carcinogenicity.** There is currently no evidence to suggest that this chemical is carcinogenic.

**Environmental Fate.** A portion of releases to land and water will quickly evaporate, although some degradation by microorganisms will occur.

Xylenes are moderately mobile in soils and may leach into groundwater, where they may persist for several years.

Xylenes are volatile organic chemicals. As such, xylene in the lower atmosphere will react with other atmospheric components, contributing to the formation of ground-level ozone and other air pollutants.

Methyl Ethyl Ketone (CAS: 78-93-3)

**Sources.** Methyl ethyl ketone (MEK) is used in some refineries as a solvent in lube oil dewaxing. Its extremely volatile characteristic makes fugitive emissions its primary source of releases to the environment.

**Toxicity.** Breathing moderate amounts of methyl ethyl ketone (MEK) for short periods of time can cause adverse effects on the nervous system ranging from headaches, dizziness, nausea, and numbness in the fingers and toes to unconsciousness. Its vapors are irritating to the skin, eyes, nose, and throat

and can damage the eyes. Repeated exposure to moderate to high amounts may cause liver and kidney effects.

**Carcinogenicity.** No agreement exists over the carcinogenicity of MEK. One source believes MEK is a possible carcinogen in humans based on limited animal evidence. Other sources believe that there is insufficient evidence to make any statements about possible carcinogenicity.

**Environmental Fate.** Most of the MEK released to the environment will end up in the atmosphere. MEK can contribute to the formation of air pollutants in the lower atmosphere. It can be degraded by microorganisms living in water and soil.

**Physical Properties.** Methyl ethyl ketone is a flammable liquid.

Propylene (CAS: 115-07-1)

**Sources.** Propylene (propene) is one of the light ends formed during catalytic and thermal cracking and coking operations. It is usually collected and used as a feedstock to the alkylation unit. Propylene is volatile and soluble in water making releases to both air and water significant.

**Toxicity.** At low concentrations, inhalation of propylene causes mild intoxication, a tingling sensation, and an inability to concentrate. At higher concentrations, unconsciousness, vomiting, severe vertigo, reduced blood pressure, and disordered heart rhythms may occur. Skin or eye contact with propylene causes freezing burns.

Reaction of propylene (see environmental fate) in the atmosphere contributes to the formation of ozone in the lower atmosphere. Ozone can affect the respiratory system, especially in sensitive individuals such as asthma or allergy sufferers.

Ecologically, similar to ethylene, propylene has a stimulating effect on plant growth at low concentrations, but inhibits plant growth at high levels.

**Carcinogenicity.** There is currently no evidence to suggest that this chemical is carcinogenic.

**Environmental Fate.** Propylene is degraded principally by hydroxyl ions in the atmosphere. Propylene released to soil and water is removed primarily through volatilization. Hydrolysis, bioconcentration, and soil adsorption are not expected to be significant fate processes of propylene in soil or aquatic

ecosystems. Propylene is readily biodegraded by microorganisms in surface water.

**Physical Properties.** Propylene is a volatile organic chemical.

Benzene (CAS: 71-43-2)

**Sources.** Benzene is a component of crude oil and is therefore present in many refining operations. Benzene is also produced during catalytic reforming and is sold as one of the large volume aromatics used as feedstocks in chemical manufacturing. Benzene's volatile nature makes fugitive emissions the largest release source. Point air sources may arise during the process of separating benzene from other aromatics.

**Toxicity.** Short-term inhalation of benzene primarily affects the central nervous system and respiratory system. Chronic exposure to benzene causes bone marrow toxicity in animals and humans, causing suppression of the immune system and development of leukemia. Ingestion of benzene is rare.

Reactions of benzene (see environmental fate) in the atmosphere contributes to the formation of ozone in the lower atmosphere (troposphere). Ozone can affect the respiratory system, especially in sensitive individuals such as asthma or allergy sufferers.

**Carcinogenicity.** Benzene is a known human carcinogen, based on both oral and inhalation exposures.

**Environmental Fate.** A portion of benzene releases to soil and surface waters evaporate rapidly. Benzene is highly mobile in the soil and may leach to groundwater. Once in groundwater, it is likely biodegraded by microorganisms only in the presence of oxygen.

Benzene is not expected to significantly adsorb to sediments, bioconcentrate in aquatic organisms or break down in water. Atmospheric benzene is broken down through reacting with chemical ions in the air; this process is greatly accelerated in the presence of other air pollutants such as nitrogen oxides or sulfur dioxide. Benzene is fairly soluble in water and is removed from the atmosphere in rain.

As a volatile chemical, benzene in the lower atmosphere will react with other atmospheric components, contributing to the formation of ground-level ozone and other air pollutants, which can contribute to respiratory illnesses in both the general and highly susceptible populations, such as asthmatics and allergy-sufferers.

#### IV.C. Other Data Sources

In addition to chemicals covered under TRI, many other chemicals are released. For example, the EPA Office of Air Quality Planning and Standards has compiled air pollutant emission factors for determining the total air emissions of priority pollutants (e.g., VOCs, SO<sub>x</sub>, NO<sub>x</sub>, CO, particulates, etc.) from many refinery sources.<sup>77</sup>

The EPA Office of Air's Aerometric Information Retrieval System (AIRS) contains a wide range of information related to stationary sources of air pollution, including the emissions of a number of air pollutants which may be of concern within a particular industry. With the exception of volatile organic compounds (VOCs), there is little overlap with the TRI chemicals reported above. Exhibit 18 summarizes annual releases of carbon monoxide (CO), nitrogen dioxide (NO<sub>2</sub>), particulate matter of 10 microns or less (PM10), total particulates (PT), sulfur dioxide (SO<sub>2</sub>), and volatile organic compounds (VOCs).

<b>Exhibit 21: Pollutant Releases (short tons/year)</b>						
<b>Industry Sector</b>	<b>CO</b>	<b>NO<sub>2</sub></b>	<b>PM<sub>10</sub></b>	<b>PT</b>	<b>SO<sub>2</sub></b>	<b>VOC</b>
Metal Mining	5,391	28,583	39,359	140,052	84,222	1,283
Nonmetal Mining	4,525	28,804	59,305	167,948	24,129	1,736
Lumber and Wood Production	123,756	42,658	14,135	63,761	9,419	41,423
Furniture and Fixtures	2,069	2,981	2,165	3,178	1,606	59,426
Pulp and Paper	624,291	394,448	35,579	113,571	541,002	96,875
Printing	8,463	4,915	399	1,031	1,728	101,537
Inorganic Chemicals	166,147	103,575	4,107	39,062	182,189	52,091
Organic Chemicals	146,947	236,826	26,493	44,860	132,459	201,888
Petroleum Refining	419,311	380,641	18,787	36,877	648,155	369,058
Rubber and Misc. Plastics	2,090	11,914	2,407	5,355	29,364	140,741
Stone, Clay and Concrete	58,043	338,482	74,623	171,853	339,216	30,262
Iron and Steel	1,518,642	138,985	42,368	83,017	238,268	82,292
Nonferrous Metals	448,758	55,658	20,074	22,490	373,007	27,375
Fabricated Metals	3,851	16,424	1,185	3,136	4,019	102,186
Computer and Office Equipment	24	0	0	0	0	0
Electronics and Other Electrical Equipment and Components	367	1,129	207	293	453	4,854
Motor Vehicles, Bodies, Parts and Accessories	35,303	23,725	2,406	12,853	25,462	101,275
Dry Cleaning	101	179	3	28	152	7,310
Source: U.S. EPA Office of Air and Radiation, AIRS Database, May 1995.						

#### IV.D. Comparison of Toxic Release Inventory Between Selected Industries

The following information is presented as a comparison of pollutant release and transfer data across industrial categories. It is provided to give a general sense as to the relative scale of releases and transfers within each sector profiled under this project. Please note that the following figure and table do not contain releases and transfers for industrial categories that are not included in this project, and thus cannot be used to draw conclusions regarding the total release and transfer amounts that are reported to TRI. Similar information is available within the annual TRI Public Data Release Book.

Exhibit 22 is a graphical representation of a summary of the 1993 TRI data for the petroleum refining industry and the other sectors profiled in separate notebooks. The bar graph presents the total TRI releases and total transfers on the left axis and the triangle points show the average releases per facility on the right axis. Industry sectors are presented in the order of increasing total TRI releases. The graph is based on the data shown in Exhibit 23 and is meant to facilitate comparisons between the relative amounts of releases, transfers, and releases per facility both within and between these sectors. The reader should note, however, that differences in the proportion of facilities captured by TRI exist between industry sectors. This can be a factor of poor SIC matching and relative differences in the number of facilities reporting to TRI from the various sectors. In the case of petroleum refining, the 1993 TRI data presented here covers 159 facilities. These facilities listed SIC 2911 (petroleum refining) as a primary SIC code.

**Exhibit 22: Summary of 1993 TRI Data:  
Releases and Transfers by Industry**

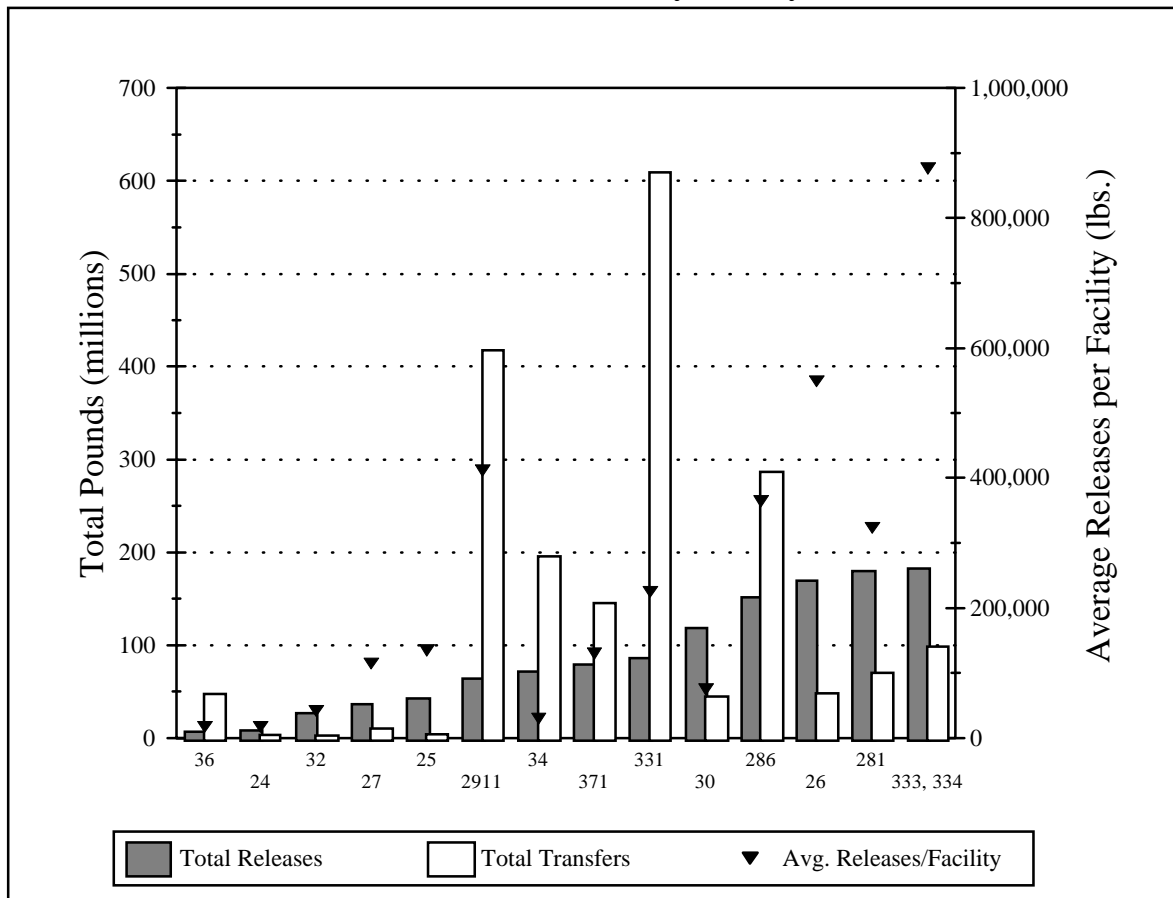

SIC Range	Industry Sector	SIC Range	Industry Sector	SIC Range	Industry Sector
36	Electronic Equipment and Components	2911	Petroleum Refining	286	Organic Chemical Mfg.
24	Lumber and Wood Products	34	Fabricated Metals	26	Pulp and Paper
32	Stone, Clay, and Concrete	371	Motor Vehicles, Bodies, Parts, and Accessories	281	Inorganic Chemical Mfg.
27	Printing	331	Iron and Steel	333,334	Nonferrous Metals
25	Wood Furniture and Fixtures	30	Rubber and Misc. Plastics		

**Exhibit 23: Toxics Release Inventory Data for Selected Industries**

Industry Sector	SIC Range	# TRI Facilities	1993 TRI Releases		1993 TRI Transfers		Total Releases + Transfers (million lbs.)	Average Releases + Transfers per Facility (pounds)	
			Total Releases (million lbs.)	Average Releases per Facility (pounds)	Total Transfers (million lbs.)	Average Transfers per Facility (pounds)			
Stone, Clay, and Concrete	32	634	26.6	42,000	2.2	4,000	28.8	46,000	
Lumber and Wood Products	24	491	8.4	17,000	3.5	7,000	11.9	24,000	
Furniture and Fixtures	25	313	42.2	135,000	4.2	13,000	46.4	148,000	
Printing	27	318	36.5	115,000	10.2	32,000	46.7	147,000	
Electronic Equip. and Components	36	406	6.7	17,000	47.1	116,000	53.7	133,000	
Rubber and Misc. Plastics	30	1,579	118.4	75,000	45	29,000	163.4	104,000	
Motor Vehicles, Bodies, Parts, and Accessories	371	609	79.3	130,000	145.5	239,000	224.8	369,000	
Pulp and Paper	2611-2631	309	169.7	549,000	48.4	157,000	218.1	706,000	
Inorganic Chem. Mfg.	281	555	179.6	324,000	70	126,000	249.7	450,000	
<b>Petroleum Refining</b>	<b>2911</b>	<b>159</b>	<b>64.3</b>	<b>404,000</b>	<b>417.5</b>	<b>2,625,000</b>	<b>481.9</b>	<b>3,088,000</b>	
Fabricated Metals	34	2,363	72	30,000	195.7	83,000	267.7	123,000	
Iron and Steel	331	381	85.8	225,000	609.5	1,600,000	695.3	1,825,000	
Nonferrous Metals	333, 334	208	182.5	877,000	98.2	472,000	280.7	1,349,000	
Organic Chemical Mfg.	286	417	151.6	364,000	286.7	688,000	438.4	1,052,000	
Metal Mining	10	Industry sector not subject to TRI reporting.							
Nonmetal Mining	14	Industry sector not subject to TRI reporting.							
Dry Cleaning	7216	Industry sector not subject to TRI reporting.							
Source: U.S. EPA, Toxics Release Inventory Database, 1993.									

## V. POLLUTION PREVENTION OPPORTUNITIES

The best way to reduce pollution is to prevent it in the first place. Some companies have creatively implemented pollution prevention techniques that improve efficiency and increase profits while at the same time minimizing environmental impacts. This can be done in many ways such as reducing material inputs, re-engineering processes to reuse by-products, improving management practices, and employing substitution of toxic chemicals. Some smaller facilities are able to actually get below regulatory thresholds just by reducing pollutant releases through aggressive pollution prevention policies.

In order to encourage these approaches, this section provides both general and company-specific descriptions of some pollution prevention advances that have been implemented within the petroleum refining industry. While the list is not exhaustive, it does provide core information that can be used as the starting point for facilities interested in beginning their own pollution prevention projects. When possible, this section provides information from real activities that can be, or are being, implemented by this sector -- including a discussion of associated costs, time frames, and expected rates of return. This section provides summary information from activities that may be, or are being implemented by this sector. When possible, information is provided that gives the context in which the technique can be effectively used. Please note that the activities described in this section do not necessarily apply to all facilities that fall within this sector. Facility-specific conditions must be carefully considered when pollution prevention options are evaluated, and the full impacts of the change must examine how each option affects air, land and water pollutant releases.

### *Drivers and Barriers to Pollution Prevention in the Petroleum Refining Industry*

Pollution prevention in the petroleum refining industry is expected to become increasingly important as federal, state and municipal regulations become more stringent and as waste disposal costs rise. According to the American Petroleum Institute, the industry currently spends a significant amount of money every year on environmental quality and protection<sup>78</sup>. This provides the industry with a strong incentive to find ways to reduce the generation of waste and to lessen the burden of environmental compliance investments. For the petroleum refining industry, pollution prevention will primarily be realized through improved operating procedures, increased recycling, and process modifications.

A cooperative effort of the Amoco Corporation and EPA to study pollution prevention at an operating oil refinery identified a number of cost effective pollution prevention techniques for the refinery that could also be adopted by other refineries. In addition, the American Petroleum Institute (API) has

assembled a compendium of waste minimization practices for the petroleum industry based on a survey of its members. Brief descriptions of some of the more widespread pollution prevention techniques found to be effective at petroleum refineries are provided below. For more detail on the pollution prevention options listed below and for descriptions of facility- and process-specific options refer to the above mentioned documents and other pollution prevention/waste minimization documents listed in Section IX - Resource Materials.

Although numerous cases have been documented where petroleum refineries have simultaneously reduced pollution outputs and operating costs through pollution prevention techniques, there are often barriers to their implementation. The primary barrier to most pollution prevention projects is cost. Many pollution prevention options simply do not pay for themselves. Corporate investments typically must earn an adequate return on invested capital for the shareholders and some pollution prevention options at some facilities may not meet the requirements set by the companies. In addition, the equipment used in the petroleum refining industry are very capital intensive and have very long lifetimes. This reduces the incentive to make process modifications to (expensive) installed equipment that is still useful. It should be noted that pollution prevention techniques are, nevertheless, often more cost-effective than pollution reduction through end-of-pipe treatment. A case study based on the Amoco/EPA joint study claimed that the same pollution reduction currently realized through end-of-pipe regulatory requirements at the Amoco facility could be achieved at 15 percent the current costs using pollution prevention techniques.

A number of regulatory disincentives to voluntary reductions of emissions from petroleum refineries also exist. Many environmental statutes define a baseline period and measure progress in pollution reductions from that baseline. Any reduction in emissions before it is required could lower a facility's baseline emissions. Consequently, future regulations requiring a specified reduction from the baseline could be more costly to achieve because the most cost-effective reductions would already have been made. With no credit given for voluntary reductions, those facilities that do the minimum may be in fact be rewarded when emissions reductions are required.

The 1990 Clean Air Act Amendments aimed to encourage voluntary reductions above the regulatory requirements by allowing facilities to obtain emission credits for voluntary reductions in emissions. These credits would serve as offsets against any potential future facility modifications resulting in an increase in emissions. Other regulations established by the amendments, however, will require the construction of major new units within existing refineries to produce reformulated fuels. These new operations will require emission offsets in order to be permitted. This will consume many of the

credits available for existing facility modifications. A shortage of credits for facility modifications will make it difficult to receive credits for emission reductions through pollution prevention projects.

Under the Clean Water Act, discharge of water-borne pollutants is limited by NPDES permits. Refineries that easily meet their permit requirements will often have their permit limits changed to lower values. Because occasional system upsets do occur resulting in significant excursions above the normal performance values, refineries feel they must maintain a large operating margin below the permit limits to ensure continuous compliance. Those refineries that can significantly reduce water-borne emissions through pollution prevention techniques may find the risk of having their permit limits lowered to be a substantial disincentive.

Wastes failing a Toxicity Characteristic (TC) test are considered hazardous under RCRA. There is less incentive for a refinery to attempt to reduce the toxicity of such waste below the TC levels because, even though such toxicity reductions may render the waste non-hazardous, it may still have to comply with new Land Disposal treatment standards under subtitle C of RCRA before being land disposed. Similarly, there is little positive incentive to reduce the toxicity of listed refinery hazardous wastes because, once listed, the waste is subject to subtitle C regulations without regard to how much the toxicity levels are reduced.

#### Examples of Process or Equipment Modifications Options

**Place secondary seals on storage tanks** - One of the largest sources of fugitive emissions from refineries is storage tanks containing gasoline and other volatile products. These losses can be significantly reduced by installing secondary seals on storage tanks. The Amoco/EPA joint study estimated that VOC losses from storage tanks could be reduced 75 to 93 percent. Equipping an average tank with a secondary seal system was estimated to cost about \$20,000.

**Establish leak detection and repair program** - Fugitive emissions are one of the largest sources of refinery hydrocarbon emissions. A leak detection and repair (LDAR) program consists of using a portable VOC detecting instrument to detect leaks during regularly scheduled inspections of valves, flanges, and pump seals. Leaks are then repaired immediately or are scheduled for repair as quickly as possible. A LDAR program could reduce fugitive emissions 40 to 64 percent, depending on the frequency of inspections.<sup>79</sup>

**Regenerate or eliminate filtration clay** - Clay from refinery filters must periodically be replaced. Spent clay often contains significant amounts of

entrained hydrocarbons and, therefore, must be designated as hazardous waste. Back washing spent clay with water or steam can reduce the hydrocarbon content to levels so that it can be reused or handled as a nonhazardous waste. Another method used to regenerate clay is to wash the clay with naphtha, dry it by steam heating and then feed it to a burning kiln for regeneration. In some cases clay filtration can be replaced entirely with hydrotreating.

**Reduce the generation of tank bottoms** - Tank bottoms from crude oil storage tanks constitute a large percentage of refinery solid waste and pose a particularly difficult disposal problem due to the presence of heavy metals. Tank bottoms are comprised of heavy hydrocarbons, solids, water, rust and scale. Minimization of tank bottoms is carried out most cost effectively through careful separation of the oil and water remaining in the tank bottom. Filters and centrifuges can also be used to recover the oil for recycling.

**Minimize solids leaving the desalter** - Solids entering the crude distillation unit are likely to eventually attract more oil and produce additional emulsions and sludges. The amount of solids removed from the desalting unit should, therefore, be maximized. A number of techniques can be used such as: using low shear mixing devices to mix desalter wash water and crude oil; using lower pressure water in the desalter to avoid turbulence; and replacing the water jets used in some refineries with mud rakes which add less turbulence when removing settled solids.

**Minimize cooling tower blowdown** - The dissolved solids concentration in the recirculating cooling water is controlled by purging or blowing down a portion of the cooling water stream to the wastewater treatment system. Solids in the blowdown eventually create additional sludge in the wastewater treatment plant. However, the amount of cooling tower blowdown can be lowered by minimizing the dissolved solids content of the cooling water. A significant portion of the total dissolved solids in the cooling water can originate in the cooling water makeup stream in the form of naturally occurring calcium carbonates. Such solids can be controlled either by selecting a source of cooling tower makeup water with less dissolved solids or by removing the dissolved solids from the makeup water stream. Common treatment methods include: cold lime softening, reverse osmosis, or electrodialysis.

**Install vapor recovery for barge loading** - Although barge loading is not a factor for all refineries, it is an important emissions source for many facilities. One of the largest sources of VOC emissions identified during the Amoco/EPA study was fugitive emissions from loading of tanker barges. It was estimated that these emissions could be reduced 98 percent by installing

a marine vapor loss control system. Such systems could consist of vapor recovery or VOC destruction in a flare.

**Minimize FCCU decant oil sludge** - Decant oil sludge from the fluidized bed catalytic cracking unit (FCCU) can contain significant concentrations of catalyst fines. These fines often prevent the use of decant oil as a feedstock or require treatment which generates an oily catalyst sludge. Catalysts in the decant oil can be minimized by using a decant oil catalyst removal system. One system incorporates high voltage electric fields to polarize and capture catalyst particles in the oil. The amount of catalyst fines reaching the decant oil can be minimized by installing high efficiency cyclones in the reactor to shift catalyst fines losses from the decant oil to the regenerator where they can be collected in the electrostatic precipitator.

**Control of heat exchanger cleaning solids** - In many refineries, using high pressure water to clean heat exchanger bundles generates and releases water and entrained solids to the refinery wastewater treatment system. Exchanger solids may then attract oil as they move through the sewer system and may also produce finer solids and stabilized emulsions that are more difficult to remove. Solids can be removed at the heat exchanger cleaning pad by installing concrete overflow weirs around the surface drains or by covering drains with a screen. Other ways to reduce solids generation are by using anti-foulants on the heat exchanger bundles to prevent scaling and by cleaning with reusable cleaning chemicals that also allow for the easy removal of oil.

**Control of surfactants in wastewater** - Surfactants entering the refinery wastewater streams will increase the amount of emulsions and sludges generated. Surfactants can enter the system from a number of sources including: washing unit pads with detergents; treating gasolines with an end point over 400 degrees (F) thereby producing spent caustics; cleaning tank truck tank interiors; and using soaps and cleaners for miscellaneous tasks. In addition, the overuse and mixing of the organic polymers used to separate oil, water and solids in the wastewater treatment plant can actually stabilize emulsions. The use of surfactants should be minimized by educating operators, routing surfactant sources to a point downstream of the DAF unit and by using dry cleaning, high pressure water or steam to clean oil surfaces of oil and dirt.

**Thermal treatment of applicable sludges** - The toxicity and volume of some deoiled and dewatered sludges can be further reduced through thermal treatment. Thermal sludge treatment units use heat to vaporize the water and volatile components in the feed and leave behind a dry solid residue. The vapors are condensed for separation into the hydrocarbon and water components. Non-condensable vapors are either flared or sent to the refinery amine unit for treatment and use as refinery fuel gas.

**Eliminate use of open ponds** - Open ponds used to cool, settle out solids and store process water can be a significant source of VOC emissions. Wastewater from coke cooling and coke VOC removal is occasionally cooled in open ponds where VOCs easily escape to the atmosphere. In many cases, open ponds can be replaced with closed storage tanks.

**Remove unnecessary storage tanks from service** - Since storage tanks are one of the largest sources of VOC emissions, a reduction in the number of these tanks can have a significant impact. The need for certain tanks can often be eliminated through improved production planning and more continuous operations. By minimizing the number of storage tanks, tank bottom solids and decanted wastewater may also be reduced.

**Replace old boilers** - Older refinery boilers can be a significant source of SO<sub>x</sub>, NO<sub>x</sub> and particulate emissions. It is possible to replace a large number of old boilers with a single new cogeneration plant with emissions controls.

**Modify the FCCU to allow the use of catalyst fines** - Some FCCUs can be modified to recycle some of the catalyst fines generated.

**Reduce the use of 55-gallon drums** - Replacing 55-gallon drums with bulk storage can minimize the chances of leaks and spills.

**Install rupture discs and plugs** - Rupture discs on pressure relieve valves and plugs in open ended valves can reduce fugitive emissions.

**Install high pressure power washer** - Chlorinated solvent vapor degreasers can be replaced with high pressure power washers which do not generate spent solvent hazardous wastes.

**Refurbish or eliminate underground piping** - Underground piping can be a source of undetected releases to the soil and groundwater. Inspecting, repairing or replacing underground piping with surface piping can reduce or eliminate these potential sources.

#### Examples of Potential Waste Segregation and Separation Options

**Segregate process waste streams** - A significant portion of refinery waste arises from oily sludges found in combined process/storm sewers. Segregation of the relatively clean rainwater runoff from the process streams can reduce the quantity of oily sludges generated. Furthermore, there is a much higher potential for recovery of oil from smaller, more concentrated process streams.

**Control solids entering sewers** - Solids released to the wastewater sewer system can account for a large portion of a refinery's oily sludges. Solids entering the sewer system (primarily soil particles) become coated with oil and are deposited as oily sludges in the API oil/water separator. Because a typical sludge has a solids content of 5 to 30 percent by weight, preventing one pound of solids from entering the sewer system can eliminate 3 to 20 pounds of oily sludge. The Amoco/EPA study estimated that at the Yorktown facility 1,000 tons of solids per year enter the refinery sewer system. Methods used to control solids include: using a street sweeper on paved areas, paving unpaved areas, planting ground cover on unpaved areas, re-lining sewers, cleaning solids from ditches and catch basins, and reducing heat exchanger bundle cleaning solids by using antifoulants in cooling water.

**Improve recovery of oils from oily sludges** - Because oily sludges make up a large portion of refinery solid wastes, any improvement in the recovery of oil from the sludges can significantly reduce the volume of waste. There are a number of technologies currently in use to mechanically separate oil, water and solids, including: belt filter presses, recessed chamber pressure filters, rotary vacuum filters, scroll centrifuges, disc centrifuges, shakers, thermal driers and centrifuge-drier combinations.

**Identify benzene sources and install upstream water treatment** - Benzene in wastewater can often be treated more easily and effectively at the point it is generated rather than at the wastewater treatment plant after it is mixed with other wastewater.

#### Examples of Recycling Options

**Recycle and regenerate spent caustics** - Caustics used to absorb and remove hydrogen sulfide and phenol contaminants from intermediate and final product streams can often be recycled. Spent caustics may be saleable to chemical recovery companies if concentrations of phenol or hydrogen sulfide are high enough. Process changes in the refinery may be needed to raise the concentration of phenols in the caustic to make recovery of the contaminants economical. Caustics containing phenols can also be recycled on-site by reducing the pH of the caustic until the phenols become insoluble thereby allowing physical separation. The caustic can then be treated in the refinery wastewater system.

**Use oily sludges as feedstock** - Many oily sludges can be sent to a coking unit or the crude distillation unit where it becomes part of the refinery products. Sludge sent to the coker can be injected into the coke drum with the quench water, injected directly into the delayed coker, or injected into the coker blowdown contactor used in separating the quenching products. Use of sludge as a feedstock has increased significantly in recent years and is

currently carried out by most refineries. The quantity of sludge that can be sent to the coker is restricted by coke quality specifications which may limit the amount of sludge solids in the coke. Coking operations can be upgraded, however, to increase the amount of sludge that they can handle.

**Control and reuse FCCU and coke fines** - Significant quantities of catalyst fines are often present around the FCCU catalyst hoppers and reactor and regeneration vessels. Coke fines are often present around the coker unit and coke storage areas. The fines can be collected and recycled before being washed to the sewers or migrating off-site via the wind. Collection techniques include dry sweeping the catalyst and coke fines and sending the solids to be recycled or disposed of as non-hazardous waste. Coke fines can also be recycled for fuel use. Another collection technique involves the use of vacuum ducts in dusty areas (and vacuum hoses for manual collection) which run to a small baghouse for collection.

**Recycle lab samples** - Lab samples can be recycled to the oil recovery system.

#### Examples of Training and Supervision

**Train personnel to reduce solids in sewers** - A facility training program which emphasizes the importance of keeping solids out of the sewer systems will help reduce that portion of wastewater treatment plant sludge arising from the everyday activities of refinery personnel.

**Train personnel to prevent soil contamination** - Contaminated soil can be reduced by educating personnel on how to avoid leaks and spills.

#### **Examples of Potential Material Substitution**

**Use non-hazardous degreasers** - Spent conventional degreaser solvents can be reduced or eliminated through substitution with less toxic and/or biodegradable products.

**Eliminate chromates as an anti-corrosive** - Chromate containing wastes can be reduced or eliminated in cooling tower and heat exchanger sludges by replacing chromates with less toxic alternatives such as phosphates.

**Use high quality catalysts** - By using catalysts of a higher quality, process efficiencies can be increased while the required frequency of catalyst replacement can be reduced.

**Replace ceramic catalyst support with activated alumina supports** - Activated alumina supports can be recycled with spent alumina catalyst.

## VI. SUMMARY OF APPLICABLE FEDERAL STATUTES AND REGULATIONS

This section discusses the Federal regulations that may apply to this sector. The purpose of this section is to highlight and briefly describe the applicable Federal requirements, and to provide citations for more detailed information. The three following sections are included:

- Section VI.A contains a general overview of major statutes
- Section VI.B contains a list of regulations specific to this industry
- Section VI.C contains a list of pending and proposed regulations

The descriptions within Section VI are intended solely for general information. Depending upon the nature or scope of the activities at a particular facility, these summaries may or may not necessarily describe all applicable environmental requirements. Moreover, they do not constitute formal interpretations or clarifications of the statutes and regulations. For further information, readers should consult the Code of Federal Regulations and other state or local regulatory agencies. EPA Hotline contacts are also provided for each major statute.

### VI.A. General Description of Major Statutes

#### *Resource Conservation and Recovery Act (RCRA)*

The Resource Conservation And Recovery Act (RCRA) of 1976, which amended the Solid Waste Disposal Act, addresses solid (Subtitle D) and hazardous (Subtitle C) waste management activities. The Hazardous and Solid Waste Amendments (HSWA) of 1984 strengthened RCRA's hazardous waste management provisions and added Subtitle I, which governs underground storage tanks (USTs).

Regulations promulgated pursuant to Subtitle C of RCRA (40 CFR Parts 260-299) establish a "cradle-to-grave" system governing hazardous waste from the point of generation to disposal. RCRA hazardous wastes include the specific materials listed in the regulations (commercial chemical products, designated with the code "P" or "U"; hazardous wastes from specific industries/sources, designated with the code "K"; or hazardous wastes from non-specific sources, designated with the code "F") and materials which exhibit a hazardous waste characteristic (ignitability, corrosivity, reactivity, or toxicity and designated with the code "D").

Regulated entities that generate hazardous waste are subject to waste accumulation, manifesting, and record keeping standards. Facilities that treat, store, or dispose of hazardous waste must obtain a permit, either from EPA or from a State agency which EPA has authorized to implement the permitting

program. Subtitle C permits contain general facility standards such as contingency plans, emergency procedures, record keeping and reporting requirements, financial assurance mechanisms, and unit-specific standards. RCRA also contains provisions (40 CFR Part 264, Subpart S and §264.10) for conducting corrective actions which govern the cleanup of releases of hazardous waste or constituents from solid waste management units at RCRA-regulated facilities.

Although RCRA is a Federal statute, many States implement the RCRA program. Currently, EPA has delegated its authority to implement various provisions of RCRA to 46 of the 50 States.

Most RCRA requirements are not industry specific but apply to any company that transports, treats, stores, or disposes of hazardous waste. Here are some important RCRA regulatory requirements:

- **Identification of Hazardous Wastes** (40 CFR Part 261) lays out the procedure every generator should follow to determine whether the material created is considered a hazardous waste, solid waste, or is exempted from regulation.
- **Standards for Generators of Hazardous Waste** (40 CFR Part 262) establishes the responsibilities of hazardous waste generators including obtaining an ID number, preparing a manifest, ensuring proper packaging and labeling, meeting standards for waste accumulation units, and record keeping and reporting requirements. Generators can accumulate hazardous waste for up to 90 days (or 180 days depending on the amount of waste generated) without obtaining a permit.
- **Land Disposal Restrictions (LDRs)** are regulations prohibiting the disposal of hazardous waste on land without prior treatment. Under the LDRs (40 CFR Part 268), materials must meet land disposal restriction (LDR) treatment standards prior to placement in a RCRA land disposal unit (landfill, land treatment unit, waste pile, or surface impoundment). Wastes subject to the LDRs include solvents, electroplating wastes, heavy metals, and acids. Generators of waste subject to the LDRs must provide notification of such to the designated TSD facility to ensure proper treatment prior to disposal.
- **Used Oil Management Standards** (40 CFR Part 279) impose management requirements affecting the storage, transportation, burning, processing, and re-refining of the used oil. For parties that merely generate used oil, regulations establish storage standards. For a party considered a used oil marketer (one who generates and sells

off-specification used oil directly to a used oil burner), additional tracking and paperwork requirements must be satisfied.

- **Tanks and Containers** used to store hazardous waste with a high volatile organic concentration must meet emission standards under RCRA. Regulations (40 CFR Part 264-265, Subpart CC) require generators to test the waste to determine the concentration of the waste, to satisfy tank and container emissions standards, and to inspect and monitor regulated units. These regulations apply to all facilities who store such waste, including generators operating under the 90-day accumulation rule.
- **Underground Storage Tanks (USTs)** containing petroleum and CERCLA hazardous substance are regulated under Subtitle I of RCRA. Subtitle I regulations (40 CFR Part 280) contain tank design and release detection requirements, as well as financial responsibility and corrective action standards for USTs. The UST program also establishes increasingly stringent standards, including upgrade requirements for existing tanks, that must be met by 1998.
- **Boilers and Industrial Furnaces (BIFs)** that use or burn fuel containing hazardous waste must comply with strict design and operating standards. BIF regulations (40 CFR Part 266, Subpart H) address unit design, provide performance standards, require emissions monitoring, and restrict the type of waste that may be burned.

*EPA's RCRA/Superfund/UST Hotline, at (800) 424-9346, responds to questions and distributes guidance regarding all RCRA regulations. The RCRA Hotline operates weekdays from 8:30 a.m. to 7:30 p.m., ET, excluding Federal holidays.*

#### *Comprehensive Environmental Response, Compensation, And Liability Act (CERCLA)*

CERCLA, a 1980 law commonly known as Superfund, authorizes EPA to respond to releases, or threatened releases, of hazardous substances that may present an imminent and substantial endangerment to public health, welfare, or the environment. CERCLA also enables EPA to force parties responsible for environmental contamination to clean it up or to reimburse the Superfund for response costs incurred by EPA. The Superfund Amendments and Reauthorization Act (SARA) of 1986 revised various sections of CERCLA, extended the taxing authority for the Superfund, and created a free-standing law, SARA Title III, also known as the Emergency Planning and Community Right-to-Know Act (EPCRA).

The CERCLA **hazardous substance release reporting regulations** (40 CFR Part 302) direct the person in charge of a facility to report to the National Response Center (NRC) any environmental release of a hazardous substance which exceeds a reportable quantity. Reportable quantities are defined and listed in 40 CFR §302.4. A release report may trigger a response by EPA or by one or more Federal or State emergency response authorities.

EPA implements **hazardous substance responses** according to procedures outlined in the National Oil and Hazardous Substances Pollution Contingency Plan (NCP) (40 CFR Part 300). The NCP includes provisions for permanent cleanups, known as remedial actions, and other cleanups referred to as "removals." EPA generally takes remedial actions only at sites on the National Priorities List (NPL), which currently includes approximately 1,300 sites. Both EPA and states can act at other sites; however, EPA provides responsible parties the opportunity to conduct removal and remedial actions and encourages community involvement throughout the Superfund response process.

*EPA's RCRA/Superfund/UST Hotline, at (800) 424-9346, answers questions and references guidance pertaining to the Superfund program. The CERCLA Hotline operates weekdays from 8:30 a.m. to 7:30 p.m., ET, excluding Federal holidays.*

#### *Emergency Planning And Community Right-To-Know Act (EPCRA)*

The Superfund Amendments and Reauthorization Act (SARA) of 1986 created EPCRA, also known as SARA Title III, a statute designed to improve community access to information about chemical hazards and to facilitate the development of chemical emergency response plans by State and local governments. EPCRA required the establishment of State emergency response commissions (SERCs), responsible for coordinating certain emergency response activities and for appointing local emergency planning committees (LEPCs).

EPCRA and the EPCRA regulations (40 CFR Parts 350-372) establish four types of reporting obligations for facilities which store or manage specified chemicals:

- **EPCRA §302** requires facilities to notify the SERC and LEPC of the presence of any "extremely hazardous substance" (the list of such substances is in 40 CFR Part 355, Appendices A and B) if it has such substance in excess of the substance's threshold planning quantity, and directs the facility to appoint an emergency response coordinator.

- **EPCRA §304** requires the facility to notify the SERC and the LEPC in the event of a non-exempt release exceeding the reportable quantity of a CERCLA hazardous substance or an EPCRA extremely hazardous substance.
- **EPCRA §311 and §312** require a facility at which a hazardous chemical, as defined by the Occupational Safety and Health Act, is present in an amount exceeding a specified threshold of chemical use to submit to the SERC, LEPC and local fire department material safety data sheets (MSDSs) or lists of MSDS's and hazardous chemical inventory forms (also known as Tier I and II forms). This information helps the local government respond in the event of a spill or release of the chemical.
- **EPCRA §313** requires manufacturing facilities included in SIC codes 20 through 39, which have ten or more employees, and which manufacture, process, or use specified chemicals in amounts greater than threshold quantities, to submit an annual toxic chemical release report. This report, commonly known as the Form R, covers releases and transfers of toxic chemicals to various facilities and environmental media, and allows EPA to compile the national Toxic Release Inventory (TRI) database.

All information submitted pursuant to EPCRA regulations is publicly accessible, unless protected by a trade secret claim.

*EPA's EPCRA Hotline, at (800) 535-0202, answers questions and distributes guidance regarding the emergency planning and community right-to-know regulations. The EPCRA Hotline operates weekdays from 8:30 a.m. to 7:30 p.m., ET, excluding Federal holidays.*

### *Clean Water Act (CWA)*

The primary objective of the Federal Water Pollution Control Act, commonly referred to as the CWA, is to restore and maintain the chemical, physical, and biological integrity of the nation's surface waters. Pollutants regulated under the CWA include "priority" pollutants, including various toxic pollutants; "conventional" pollutants, such as biochemical oxygen demand (BOD), total suspended solids (TSS), fecal coliform, oil and grease, and pH; and "non-conventional" pollutants, including any pollutant not identified as either conventional or priority.

The CWA regulates both direct and indirect discharges. The **National Pollutant Discharge Elimination System (NPDES)** program (CWA §402) controls direct discharges into navigable waters. Direct discharges or "point

source" discharges are from sources such as pipes and sewers. NPDES permits, issued by either EPA or an authorized State (EPA has presently authorized forty States to administer the NPDES program), contain industry-specific, technology-based and/or water quality-based limits, and establish pollutant monitoring reporting requirements. A facility that intends to discharge into the nation's waters must obtain a permit prior to initiating a discharge. A permit applicant must provide quantitative analytical data identifying the types of pollutants present in the facility's effluent. The permit will then set forth the conditions and effluent limitations under which a facility may make a discharge.

A NPDES permit may also include discharge limits based on Federal or State water quality criteria or standards, that were designed to protect designated uses of surface waters, such as supporting aquatic life or recreation. These standards, unlike the technological standards, generally do not take into account technological feasibility or costs. Water quality criteria and standards vary from State to State, and site to site, depending on the use classification of the receiving body of water. Most States follow EPA guidelines which propose aquatic life and human health criteria for many of the 126 priority pollutants.

#### Storm Water Discharges

In 1987 the CWA was amended to require EPA to establish a program to address **storm water discharges**. In response, EPA promulgated the NPDES storm water permit application regulations. Stormwater discharge associated with industrial activity means the discharge from any conveyance which is used for collecting and conveying stormwater and which is directly related to manufacturing, processing or raw material storage areas at an industrial plant (40 CFR 122.26(b)(14)). These regulations require that facilities with the following storm water discharges apply for an NPDES permit: (1) a discharge associated with industrial activity; (2) a discharge from a large or medium municipal storm sewer system; or (3) a discharge which EPA or the State determines to contribute to a violation of a water quality standard or is a significant contributor of pollutants to waters of the United States.

The term "storm water discharge associated with industrial activity" means a storm water discharge from one of 11 categories of industrial activity defined at 40 CFR 122.26. Six of the categories are defined by SIC codes while the other five are identified through narrative descriptions of the regulated industrial activity. If the primary SIC code of the facility is one of those identified in the regulations, the facility is subject to the storm water permit application requirements. If any activity at a facility is covered by one of the five narrative categories, storm water discharges from those areas where the

activities occur are subject to storm water discharge permit application requirements.

Those facilities/activities that are subject to storm water discharge permit application requirements are identified below. To determine whether a particular facility falls within one of these categories, the regulation should be consulted.

**Category i:** Facilities subject to storm water effluent guidelines, new source performance standards, or toxic pollutant effluent standards.

**Category ii:** Facilities classified as SIC 24-lumber and wood products (except wood kitchen cabinets); SIC 26-paper and allied products (except paperboard containers and products); SIC 28-chemicals and allied products (except drugs and paints); SIC 291-petroleum refining; and SIC 311-leather tanning and finishing.

**Category iii:** Facilities classified as SIC 10-metal mining; SIC 12-coal mining; SIC 13-oil and gas extraction; and SIC 14-nonmetallic mineral mining.

**Category iv:** Hazardous waste treatment, storage, or disposal facilities.

**Category v:** Landfills, land application sites, and open dumps that receive or have received industrial wastes.

**Category vi:** Facilities classified as SIC 5015-used motor vehicle parts; and SIC 5093-automotive scrap and waste material recycling facilities.

**Category vii:** Steam electric power generating facilities.

**Category viii:** Facilities classified as SIC 40-railroad transportation; SIC 41-local passenger transportation; SIC 42-trucking and warehousing (except public warehousing and storage); SIC 43-U.S. Postal Service; SIC 44-water transportation; SIC 45-transportation by air; and SIC 5171-petroleum bulk storage stations and terminals.

**Category ix:** Sewage treatment works.

**Category x:** Construction activities except operations that result in the disturbance of less than five acres of total land area.

**Category xi:** Facilities classified as SIC 20-food and kindred products; SIC 21-tobacco products; SIC 22-textile mill products; SIC 23-apparel related products; SIC 2434-wood kitchen cabinets manufacturing; SIC 25-furniture

and fixtures; SIC 265-paperboard containers and boxes; SIC 267-converted paper and paperboard products; SIC 27-printing, publishing, and allied industries; SIC 283-drugs; SIC 285-paints, varnishes, lacquer, enamels, and allied products; SIC 30-rubber and plastics; SIC 31-leather and leather products (except leather and tanning and finishing); SIC 323-glass products; SIC 34-fabricated metal products (except fabricated structural metal); SIC 35-industrial and commercial machinery and computer equipment; SIC 36-electronic and other electrical equipment and components; SIC 37-transportation equipment (except ship and boat building and repairing); SIC 38-measuring, analyzing, and controlling instruments; SIC 39-miscellaneous manufacturing industries; and SIC 4221-4225-public warehousing and storage.

### Pretreatment Program

Another type of discharge that is regulated by the CWA is one that goes to a publicly-owned treatment works (POTWs). The national **pretreatment program** (CWA §307(b)) controls the indirect discharge of pollutants to POTWs by "industrial users." Facilities regulated under §307(b) must meet certain pretreatment standards. The goal of the pretreatment program is to protect municipal wastewater treatment plants from damage that may occur when hazardous, toxic, or other wastes are discharged into a sewer system and to protect the toxicity characteristics of sludge generated by these plants. Discharges to a POTW are regulated primarily by the POTW itself, rather than the State or EPA.

EPA has developed general pretreatment standards and technology-based standards for industrial users of POTWs in many industrial categories. Different standards may apply to existing and new sources within each category. "Categorical" pretreatment standards applicable to an industry on a nationwide basis are developed by EPA. In addition, another kind of pretreatment standard, "local limits," are developed by the POTW in order to assist the POTW in achieving the effluent limitations in its NPDES permit.

Regardless of whether a State is authorized to implement either the NPDES or the pretreatment program, if it develops its own program, it may enforce requirements more stringent than Federal standards.

*EPA's Office of Water, at (202) 260-5700, will direct callers with questions about the CWA to the appropriate EPA office. EPA also maintains a bibliographic database of Office of Water publications which can be accessed through the Ground Water and Drinking Water resource center, at (202) 260-7786.*

*Safe Drinking Water Act (SDWA)*

The SDWA mandates that EPA establish regulations to protect human health from contaminants in drinking water. The law authorizes EPA to develop national drinking water standards and to create a joint Federal-State system to ensure compliance with these standards. The SDWA also directs EPA to protect underground sources of drinking water through the control of underground injection of liquid wastes.

EPA has developed primary and secondary drinking water standards under its SDWA authority. EPA and authorized States enforce the primary drinking water standards, which are, contaminant-specific concentration limits that apply to certain public drinking water supplies. Primary drinking water standards consist of maximum contaminant level goals (MCLGs), which are non-enforceable health-based goals, and maximum contaminant levels (MCLs), which are enforceable limits set as close to MCLGs as possible, considering cost and feasibility of attainment.

The SDWA **Underground Injection Control** (UIC) program (40 CFR Parts 144-148) is a permit program which protects underground sources of drinking water by regulating five classes of injection wells. UIC permits include design, operating, inspection, and monitoring requirements. Wells used to inject hazardous wastes must also comply with RCRA corrective action standards in order to be granted a RCRA permit, and must meet applicable RCRA land disposal restrictions standards. The UIC permit program is primarily State-enforced, since EPA has authorized all but a few States to administer the program.

The SDWA also provides for a Federally-implemented Sole Source Aquifer program, which prohibits Federal funds from being expended on projects that may contaminate the sole or principal source of drinking water for a given area, and for a State-implemented Wellhead Protection program, designed to protect drinking water wells and drinking water recharge areas.

*EPA's Safe Drinking Water Hotline, at (800) 426-4791, answers questions and distributes guidance pertaining to SDWA standards. The Hotline operates from 9:00 a.m. through 5:30 p.m., ET, excluding Federal holidays.*

*Toxic Substances Control Act (TSCA)*

TSCA granted EPA authority to create a regulatory framework to collect data on chemicals in order to evaluate, assess, mitigate, and control risks which may be posed by their manufacture, processing, and use. TSCA provides a variety of control methods to prevent chemicals from posing unreasonable risk.

TSCA standards may apply at any point during a chemical's life cycle. Under TSCA §5, EPA has established an inventory of chemical substances. If a chemical is not already on the inventory, and has not been excluded by TSCA, a premanufacture notice (PMN) must be submitted to EPA prior to manufacture or import. The PMN must identify the chemical and provide available information on health and environmental effects. If available data are not sufficient to evaluate the chemicals effects, EPA can impose restrictions pending the development of information on its health and environmental effects. EPA can also restrict significant new uses of chemicals based upon factors such as the projected volume and use of the chemical.

Under TSCA §6, EPA can ban the manufacture or distribution in commerce, limit the use, require labeling, or place other restrictions on chemicals that pose unreasonable risks. Among the chemicals EPA regulates under §6 authority are asbestos, chlorofluorocarbons (CFCs), and polychlorinated biphenyls (PCBs).

*EPA's TSCA Assistance Information Service, at (202) 554-1404, answers questions and distributes guidance pertaining to Toxic Substances Control Act standards. The Service operates from 8:30 a.m. through 4:30 p.m., ET, excluding Federal holidays.*

### *Clean Air Act (CAA)*

The CAA and its amendments, including the Clean Air Act Amendments (CAAA) of 1990, are designed to "protect and enhance the nation's air resources so as to promote the public health and welfare and the productive capacity of the population." The CAA consists of six sections, known as Titles, which direct EPA to establish national standards for ambient air quality and for EPA and the States to implement, maintain, and enforce these standards through a variety of mechanisms. Under the CAAA, many facilities will be required to obtain permits for the first time. State and local governments oversee, manage, and enforce many of the requirements of the CAAA. CAA regulations appear at 40 CFR Parts 50-99.

Pursuant to Title I of the CAA, EPA has established national ambient air quality standards (NAAQSs) to limit levels of "criteria pollutants," including carbon monoxide, lead, nitrogen dioxide, particulate matter, ozone, and sulfur dioxide. Geographic areas that meet NAAQSs for a given pollutant are classified as attainment areas; those that do not meet NAAQSs are classified as non-attainment areas. Under §110 of the CAA, each State must develop a State Implementation Plan (SIP) to identify sources of air pollution and to determine what reductions are required to meet Federal air quality standards.

Title I also authorizes EPA to establish New Source Performance Standards (NSPSs), which are nationally uniform emission standards for new stationary sources falling within particular industrial categories. NSPSs are based on the pollution control technology available to that category of industrial source but allow the affected industries the flexibility to devise a cost-effective means of reducing emissions.

Under Title I, EPA establishes and enforces National Emission Standards for Hazardous Air Pollutants (NESHAPs), nationally uniform standards oriented towards controlling particular hazardous air pollutants (HAPs). Title III of the CAAA further directed EPA to develop a list of sources that emit any of 189 HAPs, and to develop regulations for these categories of sources. To date EPA has listed 174 categories and developed a schedule for the establishment of emission standards. The emission standards are being developed for both new and existing sources based on "maximum achievable control technology (MACT)." The MACT is defined as the control technology achieving the maximum degree of reduction in the emission of the HAPs, taking into account cost and other factors.

Title II of the CAA pertains to mobile sources, such as cars, trucks, buses, and planes. Reformulated gasoline, automobile pollution control devices, and vapor recovery nozzles on gas pumps are a few of the mechanisms EPA uses to regulate mobile air emission sources.

Title IV establishes a sulfur dioxide emissions program designed to reduce the formation of acid rain. Reduction of sulfur dioxide releases will be obtained by granting to certain sources limited emissions allowances, which, beginning in 1995, will be set below previous levels of sulfur dioxide releases.

Title V of the CAAA of 1990 created an operating permit program for all "major sources" (and certain other sources) regulated under the CAA. One purpose of the operating permit is to include in a single document all air emissions requirements that apply to a given facility. States are developing the permit programs in accordance with guidance and regulations from EPA. Once a State program is approved by EPA, permits will be issued and monitored by that State.

Title VI is intended to protect stratospheric ozone by phasing out the manufacture of ozone-depleting chemicals and restricting their use and distribution. Production of Class I substances, including 15 kinds of chlorofluorocarbons (CFCs), will be phased out entirely by the year 2000, while certain hydrochlorofluorocarbons (HCFCs) will be phased out by 2030.

*EPA's Control Technology Center, at (919) 541-0800, provides general assistance and information on CAA standards. The Stratospheric Ozone*

*Information Hotline, at (800) 296-1996, provides general information about regulations promulgated under Title VI of the CAA, and EPA's EPCRA Hotline, at (800) 535-0202, answers questions about accidental release prevention under CAA §112(r). In addition, the Technology Transfer Network Bulletin Board System (modem access (919) 541-5742)) includes recent CAA rules, EPA guidance documents, and updates of EPA activities.*

## VI.B. Industry Specific Requirements

The petroleum refining industry is unique in that the environmental requirements aimed at the industry are of two basic types: (1) requirements mandating specific product qualities for the purpose of reducing the environmental impacts associated with the downstream use of the product; and (2) requirements directed at reducing the environmental impacts of the refineries themselves. Presently, some of the most significant environmental statutes affecting refineries economically are geared toward altering the product formulation with the aim of reducing pollutant releases from use of the finished products (primarily fuels). Since 1970, various product quality regulations have been promulgated affecting specific formulations of gasoline and other fuels. These formulations often require significant process changes and capital investments at petroleum refineries. Environmental requirements aimed at reducing the pollution outputs from refinery operations themselves also require significant investments to change the processes and equipment. These requirements aimed at reformulating refinery products and reducing emissions from refinery operations make petroleum refining one of the most heavily regulated industries.

### *Clean Air Act of 1970 (CAA)*

Of the various environmental statutes affecting the industry, the CAA of 1970 and the CAAA of 1990 have had, and will continue to have, the most significant impact on the petroleum refining industry.

The 1970 CAA authorized EPA to establish, in 1971, the National Ambient Air Quality Standards (NAAQS) which set standards for sulfur dioxide, nitrous oxides, carbon monoxide, ozone, non-methane hydrocarbons, opacity and total suspended particulates in the ambient air. The Act also established a schedule for the reduction and eventual elimination of lead in gasoline. In 1978, a national ambient air standard for lead was established. More complex refining techniques such as incorporating more downstream conversion units, catalytic processes, octane boosting additives, and lubricating additives, were developed to make up for the properties lost as a result of reducing lead anti-knock additives. Another provision of the Act limited the sulfur content in residual and distillate fuel oils used by electric utilities and industrial plants.

To meet the demand for low-sulfur fuels, desulfurization processing units were developed.<sup>80</sup>

### *Clean Air Act Amendments of 1990 (CAAA)*

Despite a major reduction in automobile emissions after the 1970 CAA, many areas of the U.S. were not in compliance with the NAAQS. These areas, termed "nonattainment areas," became an important subject of the 1990 amendments to the 1970 CAA. The CAAA of 1990 provide much more stringent requirements than the original CAA. The Act is organized into nine titles: Urban Air Quality, Mobile Sources, Toxic Air Pollutants, Acid Rain Control, Permits, Stratospheric Ozone Depletion, Enforcement, General Provisions, and Research. The major requirements altering product formulations to reduce emissions from mobile sources are contained in four programs: the Oxygenated Fuels Program, the Highway Diesel Fuel Program, the Reformulated Fuels Program, and the Leaded Gasoline Removal Program. Additional programs aimed at reducing air emissions from the refineries themselves and which have significant impacts on refineries include: New Source Review (NSR), New Source Performance Standards (NSPS), and National Emission Standards for Hazardous Air Pollutants (NESHAP).<sup>81</sup>

#### Oxygenated Fuels Program

The Oxygenated Fuels Program required that by November 1992, all gasoline sold in the 39 carbon monoxide nonattainment areas must have a minimum of 2.7 percent oxygen (by weight) for at least four winter months. The higher oxygen content lowers the levels of carbon monoxide produced during combustion. In California's carbon monoxide nonattainment areas, the winter fuel oxygen content is set at 1.8 to 2.2 percent because it is expected that higher oxygen levels increase nitrogen oxide emissions to unacceptable levels (for which the area is also in nonattainment).

In response to the program, the domestic capacity to produce oxygenates for oxygenated fuels has increased 59 percent from 1991 to 1993. This required significant investments in oxygenate production facilities at both refineries and at nonrefinery stand-alone facilities that produce ethanol from grain, methyl tertiary butyl ether (MTBE) from oil field butane streams, and methanol from natural gas.<sup>82</sup> The mandatory use of ethanol as an oxygenate, however, was overturned by a court in May of 1995.

#### Highway Diesel Fuel Program

The Highway Diesel Fuel Program required that the sulfur content of all highway diesel fuel be reduced from 0.5 percent to 0.05 percent (by weight) by October 1, 1993. Small refineries (below 18,250 thousand barrels of crude oil throughput per year) were given the option of using tradeable credits on sulfur reduction as a means of compliance until December 31, 1999. The program also requires that the cetane index, which measures the self-ignition quality of diesel fuel, must be maintained at a minimum of 40.

Increased construction of desulfurization downstream units, such as catalytic hydrocracking and hydrotreating units is underway to comply with these new requirements. Small refineries not wanting to invest in new downstream units may have the option of producing only distillate fuel oil for non-highway use. Diesel fuel and distillate fuel oils can be interchanged; however, as of October 1, 1993, distillate fuel oil and diesel fuel with high sulfur content were marked with a dye to prevent sale for highway use. Industry estimates a capital cost of \$3.3 billion to comply with the Highway Diesel Fuel Program.<sup>83</sup>

#### Reformulated Fuels Program

The Reformulated Fuels Program, or Reformulated Gasoline (RFG) Program, requires the use of reformulated gasoline by January 1, 1995 in nine U.S. metropolitan areas (more than 250,000 people) with the worst ground level ozone problems. Other nonattainment areas can "opt in" to the program as a way of reducing ozone levels. EPA can delay a request to opt-in for up to three years if the supply of reformulated gasoline is not large enough. Such reformulated gasoline must have a minimum oxygen content of two percent by weight, a maximum benzene content of one percent by volume, and no lead or manganese. In addition, the year round average of nitrogen oxide emissions may not exceed that of a 1990 summertime baseline gasoline; the 1990 baseline tailpipe emissions of volatile organic compounds and toxic air pollutants (TAPs) must be reduced by 15 percent; and benzene must be below 1 percent. By 1998, a new "complex" formula for reformulated gasoline will replace the original "simple" formula. By 2000, TAPs emissions are to be reduced by at least 20 percent, VOC emissions reduced by at least 25 percent, and NO<sub>x</sub> emissions reduced by at least 5 percent in the summertime.<sup>84</sup>

Of the four highway fuels programs, complying with the reformulated gasoline rules will require the largest process changes. Gasoline formulation will need to be upgraded to reduce the aromatic and VOC emissions from motor vehicles. The catalytic reforming process is expected to be used less, thereby lowering the levels of benzene and other aromatics produced. Hydrotreating units will be utilized more in order to meet the lower sulfur specifications. It is uncertain how many nonattainment areas will eventually opt-in to the program, which could have a significant effect on the capacity

needs for the various downstream processes. As of June 1995, 18 areas have opted-in.

#### Leaded Gasoline Removal Program

The fourth program to limit emissions from mobile sources prohibits the sale of leaded gasoline for use in motor vehicles after 1995. The CAA 1970 has already reduced lead content substantially and the elimination of leaded gas is not expected to create significant changes in the industry.<sup>85</sup>

#### Reid Vapor Pressure Regulations of 1989 and 1992

The Reid Vapor Pressure (RVP) regulations were implemented by the EPA to reduce emissions of VOCs and other ozone precursors. The regulations set standards for the volatility of summertime motor gasoline in some U.S. urban areas. The program was implemented in two phases with the first beginning in the spring of 1989 and the second in 1992. The Phase I summer volatility standards limited the average Reid Vapor Pressure (a measure of the volatility of motor gasoline) to a maximum of 10.5 psi and 9.0 psi in certain areas of the country. The Phase II summer volatility standards set a nationwide maximum RVP of 9.0 psi and, in some ozone nonattainment cities in the south, the standard was set at 7.8 psi. Phase II will stay in effect through the summer of 1994 in the nine RFG areas. In 1995, the VOC standards of the 1990 CAAA Reformulated Gasoline Program will take the place of the RVP regulations.

The Phase I standards were met by reducing the amount of butane blended into gasoline. In addition to having a high RVP, butane is also high octane. To compensate for the resulting loss in octane and volume both crude oil inputs and the use of catalytic cracking and alkylation units have increased. The Phase II standards were met by increasing downstream processing and the blending with high-octane, lower RVP components. To meet the RVP regulations, large capital investments were made in facilities to produce these blending components.<sup>86</sup>

#### New Source Review and New Source Performance Standards

The 1990 CAA New Source Review (NSR) requirements apply to new facilities, expansions of existing facilities, or process modifications. New sources of the NAAQS "criteria" pollutants in excess of "major" levels defined by EPA are subject to NSR requirements (40 CFR §52.21(b)(1)(i)(a)-(b)). NSRs are typically conducted by the state agency under standards set by EPA and adopted by the state as part of its state implementation plan (SIP). There are two types of NSRs: Prevention of Significant Deterioration (PSD) reviews for those areas that are meeting the NAAQS; and

nonattainment (NA) reviews for areas that are violating the NAAQS. Permits are required to construct or operate the new source for PSD and NA areas. For NA areas, permits require the new source to meet lowest achievable emission rate (LAER) standards and the operator of the new source must procure reductions in emissions of the same pollutants from other sources in the NA area in equal or greater amounts to the new source. These "emission offsets" may be banked and traded through state agencies. For PSD areas, permits require the best available control technology (BACT), and the operator or owner of the new source must conduct continuous on-site air quality monitoring for one year prior to the new source addition to determine the effects that the new emissions may have on air quality. EPA sets the minimum standards for LAER and BACT for petroleum refinery NSRs in its new source performance standards (NSPS), 40 CFR Part 60:

Subpart J	Standards of Performance for Petroleum Refineries
Subpart K,K,K	Standards of Performance for Volatile Organic Liquid Storage Vessels
Subpart GG	Standards of Performance for Stationary Gas Turbines
Subpart GGG	Standards of Performance for Equipment Leaks of VOC in Petroleum Refineries
Subpart NNN	Standards of Performance for VOC Emissions from SOCFI Distillation Operations (manufacturing of organic chemicals e.g., MTBE)
Subpart QQQ	Standards of Performance for VOC Emissions from Petroleum Wastewater Systems <sup>87,88</sup>

#### National Emission Standards for Hazardous Air Pollutants (NESHAP)

Under Title III of the 1990 CAAA, EPA is required to develop national emission standards for 189 hazardous air pollutants (NESHAP) including benzene and approximately 20 other chemicals typically emitted at petroleum refineries. The development of the NESHAP regulations are taking place in two phases. In the first phase, EPA is developing maximum achievable control technology (MACT) standards for all new and existing sources (James Durham, U.S. EPA, Office of Air, (919) 541-5672). EPA can give a six year extension of NESHAP requirements in exchange for an enforceable commitment to an early reduction of emissions by 90 percent. At the time this document went to print EPA estimated that the MACT standards for petroleum refineries would be finalized by the end of July 1995. The second phase of the NESHAP regulations is to be implemented in 2000 and requires

assessing whether or not remaining risk after the MACT standards have been implemented is acceptable.<sup>89</sup> For petroleum refineries, the following NESHAPs apply, 40 CFR Part 61:

Subpart J	National Emission Standards for Equipment Leaks of Benzene
Subpart M	National Emission Standards for Asbestos (Demolition and Renovation)
Subpart V	National Emission Standards for Equipment Leaks (Fugitive Emission Sources)
Subpart Y	National Emission Standards for Benzene Emissions from Benzene Storage Tanks
Subpart BB	National Emission Standards for Benzene Emissions from Benzene Transfer Operations
Subpart FF	National Emission Standards for Benzene Waste Operations

In addition, Subpart E (National Emission Standards for Mercury) will apply if the refinery has a wastewater treatment plant sludge incinerator.<sup>90</sup>

#### *Resource Conservation and Recovery Act (RCRA)*

RCRA gives EPA the authority to establish a list of solid and hazardous wastes, and to establish standards and regulations for handling and disposing of these wastes. Although the costs of complying with RCRA requirements may not be as great as that of the 1990 CAAA, there are significant capital and operational costs as well as administrative costs related to permitting, technical studies and analytical requirements.

The majority of solid wastes generated at refineries are non-hazardous residuals. Most of these wastes are typically recycled within the refinery or are landfilled or incinerated onsite as non-hazardous wastes. Some of these wastes are sent off-site for treatment, land disposal or land treatment (land farming). A number of wastes commonly generated at refineries, however, are hazardous under RCRA. The largest number of different RCRA hazardous wastes are generated during wastewater treatment prior to discharge. These could include: API separator sludge (K051); slop oil emulsion solids (K049); other primary oil-water separator sludge, barscreen debris (F037); characteristic wastes containing chromium (D007) or lead (D008); dissolved air flotation floats (K048); and all other sludge, floats and used filter bags (F038). Other potential refinery wastes regulated under RCRA include those generated from cleaning of heat exchanger bundles

(K050), desalter mud (F037), laboratory wastes (F003, F005, D001, etc.), spent alkylation sulfuric acid (D002; except when used to produce virgin sulfuric acid, 40 CFR §261.4(a)(7)) and leaded tank bottom corrosion solids (K052), waste paint materials (D001), and wastes containing benzene (D018).<sup>91</sup> Spent process catalysts are occasionally RCRA characteristic hazardous wastes for reactivity due to benzene (D018) or for toxicity due to sulfur on the catalyst surface (D003).<sup>92</sup>

Some of the handling and treating requirements for RCRA hazardous waste generators are covered under 40 CFR Part 262 and involve: determining what constitutes a RCRA hazardous waste (Subpart A); manifesting (Subpart B); packaging, labeling and accumulation time limits (Subpart C); and record keeping and reporting (Subpart D).<sup>93</sup>

Many refineries store some hazardous wastes at the facility for more than 90 days and, therefore, are a storage facility under RCRA and must have a RCRA treatment, storage and disposal facility (TSDF) permit (40 CFR §262.34). Some of the specific requirements that may apply to refineries that are TSD facilities are covered under 40 CFR Part 264, and include: contingency plans and emergency procedures (40 CFR Part 264 Subpart D); manifesting, record keeping and reporting (Subpart E); use and management of containers (Subpart I); tank systems (Subpart J); surface impoundments (Subpart K); land treatment (Subpart M); incinerators (Subpart O), although few refineries incinerate hazardous wastes onsite; corrective action of hazardous waste releases (Subpart S); air emissions standards for process vents of processes that process or generate hazardous wastes (Subpart AA); emissions standards for leaks in hazardous waste handling equipment (Subpart BB); and emissions standards for containers, tanks, and surface impoundments that contain hazardous wastes (Subpart CC).

The 1984 Hazardous and Solid Waste Amendments (HSWA) to RCRA require that any area at a facility where solid wastes have been routinely and systematically released at a treatment, storage, or disposal facility are required to carry out “corrective actions.” Corrective action requirements are decided by EPA or the states on a facility-by-facility basis and can extend to remediation beyond the facility boundary. Since most refineries have filed for RCRA permits and because it is common for refineries to have released wastes to the environment, it is expected that most refineries will eventually undergo a RCRA corrective action. The costs of remediating contamination that has occurred over the life of a refinery could potentially be one of the most costly items facing a facility.<sup>94</sup>

A number of RCRA wastes have been prohibited from land disposal unless treated to meet specific standards under the RCRA Land Disposal Restriction (LDR) program. The wastes covered by the RCRA LDRs are listed in 40

CFR Part 268, Subpart C and include a number of wastes commonly generated at petroleum refineries. Restrictions on common refinery wastes include toxicity characteristic wastes, which include those containing greater than 0.5 ppm benzene (D018) and sludges from refinery process wastewater treatment systems (F037). Restrictions on D018 wastes are expected to further reduce the amount of refinery wastes that are treated by landfarming off-site which has already been reduced significantly in recent years for both hazardous and non-hazardous wastes.<sup>95</sup> To meet the LDRs, these wastes are typically treated through incineration. In addition to the land disposal restrictions, standards for the treatment and storage of restricted wastes are also described in Subparts D and E, respectively.<sup>96</sup>

### *Clean Water Act (CWA)*

Petroleum refinery wastewater released to surface waters is regulated under the CWA. National Pollutant Discharge Elimination System (NPDES) permits must be obtained to discharge wastewater into navigable waters (40 Part 122). Effluent limitation guidelines for wastewater discharged from petroleum refineries were promulgated in 1985 and are currently being reviewed for updating in 1995 (Ronald Kirby, U.S. EPA Office of Water, (202)-260-7168). The effluent guidelines for the Petroleum Refining Point Source Category are listed under 40 CFR Part 419 and are divided into subparts according to the processes used by the refinery:

- |           |                                                                                                        |
|-----------|--------------------------------------------------------------------------------------------------------|
| Subpart A | Applies to facilities using topping (distillation) and catalytic reforming                             |
| Subpart B | Applies to facilities using topping and cracking                                                       |
| Subpart C | Applies to facilities using topping, cracking and petrochemical operations                             |
| Subpart D | Applies to facilities using topping, cracking and lube oil manufacturing                               |
| Subpart E | Applies to facilities that use topping, cracking, lube oil manufacturing and petrochemical operations. |

In addition to the effluent guidelines, facilities that discharge to a POTW may be required to meet National Pretreatment Standards for some contaminants. General pretreatment standards applying to most industries discharging to a POTW are described in 40 CFR Part 403. Pretreatment standards applying specifically to the Petroleum Refining Category are listed in the subparts of 40 CFR Part 419 (as shown above).<sup>97</sup>

The term "storm water discharge associated with industrial activity" means a storm water discharge from one of 11 categories of industrial activity defined at 40 CFR 122.26. If the primary SIC code of the facility is one of those identified in the regulations, the facility is subject to the storm water permit application requirements. If any activity at a facility is covered by one of the five narrative categories, storm water discharges from those areas where the activities occur are subject to storm water discharge permit application requirements.

Those facilities/activities that are subject to storm water discharge permit application requirements are identified below. To determine whether a particular facility falls within one of these categories, the regulation should be consulted.

**Category i:** Facilities subject to storm water effluent guidelines, new source performance standards, or toxic pollutant effluent standards.

**Category ii:** Facilities classified as SIC 24-lumber and wood products (except wood kitchen cabinets); SIC 26-paper and allied products (except paperboard containers and products); SIC 28-chemicals and allied products (except drugs and paints); SIC 291-petroleum refining; and SIC 311-leather tanning and finishing.

The recent storm water rules require certain facilities with storm water discharge from any one of 11 categories of industrial activity defined at 40 CFR 122.26 be subject to the storm water permit application requirements (see Section VI.A). Petroleum refineries are covered in Category ii by virtue of SIC code. The Storm Water Rule (40 CFR §122.26(b)(14) subparts (i, ii)) requires the capture and treatment of stormwater at all facilities falling under SIC code 291, including petroleum refineries. Required treatment of storm water flows are expected to remove a large fraction of both conventional pollutants, such as suspended solids and biological oxygen demand (BOD), as well as toxic pollutants, such as certain metals and organic compounds.<sup>98</sup>

#### *Safe Drinking Water Act (SDWA)*

Those refineries that dispose of wastewater in underground injection wells are subject to the underground injection control (UIC) program of the Safe Drinking Water Act. The UIC program is aimed at protecting usable aquifers from contaminants migrating from injection wells. The program requires a permit for the placement of fluids into a well. Injection wells are also subject to substantive standards and criteria that may require a study of the potential of the well to contaminate the groundwater (40 CFR Parts 143-147). An injection well is classified in one of five categories (Class I-V) which reflect the relative risk of contaminating usable aquifers based on the proximity to

drinking water supplies and the hydrogeological conditions in the area. Regulations vary for each well class. The UIC program is closely related to the RCRA program. Injection wells into which hazardous waste is injected constitute a land disposal facility under RCRA and, therefore, also require a RCRA permit. Under the RCRA regulations, injection wells with permits under the UIC program and which meet certain additional RCRA requirements, are considered to have a RCRA permit (40 CFR §270.60(b)).<sup>99</sup>

#### *Comprehensive Environmental Response, Compensation and Liability Act (CERCLA)*

Petroleum and crude oil are specifically exempt from listing in CERCLA. Wastes generated during the refining process and refined petroleum products containing CERCLA hazardous substances above specific levels are covered under CERCLA. Therefore, past releases of hazardous substances from a refinery are likely to require remedial clean-up actions under Superfund.<sup>100</sup>

#### *Emergency Planning and Community Right-to-Know Act (EPCRA)*

Refineries are also covered by the reporting requirements of the Emergency Planning and Community Right-to-Know Act (EPCRA). The Community Right-to-Know provisions require that facilities with ten or more employees that manufactured, processed, or otherwise used a listed toxic chemical in excess of the "established threshold" must annually file a Toxic Chemical Release form with EPA and the state (EPCRA §313; 40 CFR Part 372). Facilities must submit material safety data sheets or the equivalent and Tier I/Tier II annual inventory report forms to the appropriate local emergency planning commission and emergency response and fire departments (EPCRA §§ 311-312; 40 CFR Part 370). Those handling "extremely hazardous substances" are also required to submit a one-time notice to the state emergency response commission (EPCRA §302(A); 40 CFR Part 355). Unintentional releases of a reportable quantity of a CERCLA hazardous substance or an extremely hazardous substance must be reported to the state emergency planning commission and the local emergency planning commission (40 CFR Part 304).<sup>101</sup> Petroleum refineries are likely to use or produce a number of the chemicals listed, including ammonia, chlorine, hydrogen sulfide, methyl mercaptan, sulfur dioxide and sulfuric acid.

#### *1990 Oil Pollution Act and Spill Prevention Control and Countermeasure Plans*

The 1990 Oil Pollution Act establishes strict, joint and several liability against onshore and offshore facilities that discharge oil or pose a substantial threat of discharging oil to navigable waterways. The act requires that facilities posing a substantial threat of harm to the environment prepare and implement more rigorous Spill Prevention Control and Countermeasure Plan required under the CWA (40 CFR §112.7). Standards have been set for tank

equipment, spill prevention control plans, and vessels. An important requirement affecting refining facilities is oil response plans for above ground storage tank facilities. There are also criminal and civil penalties for deliberate or negligent spills of oil. Regulations covering response to oil discharges and contingency plans (40 CFR Part 300), and facility response plans to oil discharges (40 CFR Part 112) are being revised and finalized in 1995.<sup>102</sup>

#### *OSHA Health Standards and Process Safety Management Rules*

The Occupational Safety and Health Administration (OSHA) limits benzene exposure in the workplace at petroleum refineries (29 CFR §1910.1028). Benzene is a common emission of petroleum refining operations. Control strategies may involve substantial process changes and equipment modifications. OSHA has also developed safety management rules requiring refineries to conduct a detailed review of all operational processes to determine workplace risk and injury potential to workers and to define courses of action in the case of emergencies (29 CFR §1910). Industry reports that this regulation may prove to be relatively costly due to the numerous and complex process units at petroleum refineries.<sup>103</sup>

#### *State Statutes*

Some of the most important state regulations affecting the petroleum refining industry are those of the California Air Resource Board (CARB). The CARB Phase II regulations for reformulated gasoline sold in California are more stringent than the federal CAAA. The South Coast Air Quality Management District (SCAQMD) in southern California has an Air Quality Maintenance Plan which aims to reduce emissions of sulfur oxides, nitrogen oxides, particulates and VOCs from stationary sources. For refineries, one of the most important requirements will be an 8 percent reduction in emissions of NO<sub>x</sub> by 1996.<sup>104</sup> Refineries must also carry out a comprehensive leak identification, maintenance, and inspection program. VOC emissions from sumps, wastewater systems and sewers are also limited, and any emission increases must be offset by emission decreases within the facility. Certain refineries must conduct analyses for carcinogenic risks to neighboring populations, and new units or facility modifications cannot exceed specified limits for increased specified cancer risk to individuals in the surrounding community. Industry representatives reported that substantial emission controls and changes in facility operations would be needed to meet the SCAQMD requirements.<sup>105</sup>

Refineries are also affected by some state statutes that designate waste oils as hazardous waste. In some states, such as California, any oily waste or waste

oil generated in a refinery process must be handled as a RCRA hazardous waste.

### VI.C. Pending and Proposed Regulatory Requirements

#### *Energy Policy Act of 1992*

The Energy Policy Act of 1992 provided for a number of programs aimed at reducing the U.S. dependence on foreign oil through increased domestic oil production, the use of alternative fuels, and increases in energy efficiency. Some programs established by the Energy Policy Act may have significant effects on the petroleum refining industry in the long term.

The Energy Policy Act mandates the phase-in of alternative fuels in government and private automobile and truck fleets. A national goal for 2010 has been set for 30 percent of the light-duty vehicle market to be powered by natural gas, electricity, methanol, ethanol, or coal-derived liquid fuels. The Act also requires that efficiency standards be set for all new federal buildings, buildings with federally backed mortgages, and commercial and industrial equipment. Research and development programs are being sponsored for high-efficiency engines and superconducting electric power systems. The effects of these programs will ultimately reduce the growth rate of demand for refined petroleum products in the U.S.<sup>106</sup>

#### *Clean Water Act (CWA)*

Effluent limitations guidelines for wastewater discharge from petroleum refineries are currently being reviewed by the Office of Water for possible updating in 1995 (Ronald Kirby, U.S. EPA Office of Water, (202)-260-7168). Specifically, the Office of Water is evaluating the need to reduce selenium releases which, in the past, have exceeded water quality standards. Selenium releases are usually only found in facilities processing California crude oil. Effluent guidelines for selenium will, therefore, probably only affect these facilities.<sup>107</sup>

*Clean Air Act Amendments 1990 (CAAA)*

Most of the programs of the CAAA are being phased-in over a period of ten years between 1990 and 2000. Some of the requirements of the CAAA have not yet been set and, as mentioned above, there is a great deal of uncertainty as to the effects that these unspecified standards will have on the industry. The Reformulated Gasoline Program and the NESHAP standards may have the most significant future requirements on the industry. Under the Reformulated Gasoline Program, a "complex" formula for reformulated gasoline is scheduled to go into effect in 1998. The standards for this formula were not yet finalized as of June 1995. It is not known how many other nonattainment areas will eventually "opt in," thereby creating more demand for reformulated gasoline. Several nonattainment areas have already sought to "opt out" of the program.<sup>108</sup>

The NESHAP standards are scheduled to be promulgated by EPA by late July 1995 (James Durham, U.S. EPA, Office of Air, (919) 541-5672). The standards required will be in the form of MACT standards. The NESHAP standards will likely be similar to those developed for the chemical industry and will cover air emissions from many refinery processes including, but not limited to, most catalytic processes, industrial boilers, process heaters, storage tanks and equipment, process vents, and wastewater treatment facilities. The standards for the control of benzene emissions will require significant capital investments.<sup>109</sup>

Under Title V of the CAAA 1990 (40 CFR Parts 70-72) all of the applicable requirements of the Amendments are integrated into one federal renewable operating permit. Facilities defined as "major sources" under the Act must apply for permits within one year from when EPA approves the state permit programs. Since most state programs were not approved until after November 1994, Title V permits will, for the most part, begin to be due in late 1995. A facility is designated as a major source if it includes sources subject to the NSPS acid rain provisions or NESHAPS, or if it releases a certain amount of any one of the CAAA regulated pollutants (SO<sub>x</sub>, NO<sub>x</sub>, CO, VOC, PM<sub>10</sub>, hazardous air pollutants, extremely hazardous substances, ozone depleting substances, and pollutants covered by NSPSs) depending on the region's air quality category. Although revisions to the definition of what constitutes a major source were being negotiated at the time that this document went to press (August 1995), it is important to note that major source determination will likely be based on a facility's potential emissions and not its actual emissions. These revisions to the Title V rules were expected to be published in late August 1995. Title V permits may set limits on the amounts of pollutant emissions; require emissions monitoring, and record keeping and reporting. Under a separate rule, the Continuous Air Monitoring Rule (CAM) being developed, continuous monitoring of certain emissions

from certain facilities may be required (Peter Westlin, U.S. EPA, Office of Air, (919) 541-1058). Facilities are required to pay a fee for filing for a permit and are required to pay an annual fee based on the magnitude of the facility's potential emissions.<sup>110</sup>

*Resource Conservation and Recovery Act (RCRA)*

EPA is studying fourteen refinery theoretical waste streams for potential additions to the RCRA hazardous waste lists under a settlement agreement with the Environmental Defense Fund (Maximo Diaz, Jr., Office of Solid Waste and Emergency Response, (202)-260-4786). A decision is to be made on each stream by October 31, 1996. Treatment standards under the Land Disposal Restrictions program will be developed for any wastes listed. Alternatives to listing are also being considered, including management standards based on pollution prevention, recycling, reclamation, or feedstock to other manufacturing processes.<sup>111</sup>

In 1994, a Refinery Workgroup comprised of representatives from OSWER, Office of Water, and Office of Regulatory Council reviewed the issues surrounding a RCRA/CWA interface pertaining to contaminated ground water seeps to surface water from petroleum refineries. The legal authorities over seeps still remains unclear. In a report completed in September 1994, the Workgroup recommended that the legal authority pertaining to seeps to surface waters should be made on a case-by-case basis. The report also discussed the various authorities and circumstances in which they should be utilized.

## VII. COMPLIANCE AND ENFORCEMENT HISTORY

### Background

To date, EPA has focused much of its attention on measuring compliance with specific environmental statutes. This approach allows the Agency to track compliance with the Clean Air Act, the Resource Conservation and Recovery Act, the Clean Water Act, and other environmental statutes. Within the last several years, the Agency has begun to supplement single-media compliance indicators with facility-specific, multimedia indicators of compliance. In doing so, EPA is in a better position to track compliance with all statutes at the facility level, and within specific industrial sectors.

A major step in building the capacity to compile multimedia data for industrial sectors was the creation of EPA's Integrated Data for Enforcement Analysis (IDEA) system. IDEA has the capacity to "read into" the Agency's single-media databases, extract compliance records, and match the records to individual facilities. The IDEA system can match Air, Water, Waste, Toxics/Pesticides/EPCRA, TRI, and Enforcement Docket records for a given facility, and generate a list of historical permit, inspection, and enforcement activity. IDEA also has the capability to analyze data by geographic area and corporate holder. As the capacity to generate multimedia compliance data improves, EPA will make available more in-depth compliance and enforcement information. Additionally, sector-specific measures of success for compliance assistance efforts are under development.

### Compliance and Enforcement Profile Description

Using inspection, violation and enforcement data from the IDEA system, this section provides information regarding the historical compliance and enforcement activity of this sector. In order to mirror the facility universe reported in the Toxic Chemical Profile, the data reported within this section consists of records only from the TRI reporting universe. With this decision, the selection criteria are consistent across sectors with certain exceptions. For the sectors that do not normally report to the TRI program, data have been provided from EPA's Facility Indexing System (FINDS) which tracks facilities in all media databases. Please note, in this section, EPA does not attempt to define the actual number of facilities that fall within each sector. Instead, the section portrays the records of a subset of facilities within the sector that are well defined within EPA databases.

As a check on the relative size of the full sector universe, most notebooks contain an estimated number of facilities within the sector according to the Bureau of Census (See Section II). With sectors dominated by small businesses, such as metal finishers and printers, the reporting universe within

the EPA databases may be small in comparison to Census data. However, the group selected for inclusion in this data analysis section should be consistent with this sector's general make-up.

Following this introduction is a list defining each data column presented within this section. These values represent a retrospective summary of inspections or enforcement actions, and solely reflect EPA, state and local compliance assurance activity that have been entered into EPA databases. To identify any changes in trends, the EPA ran two data queries, one for the past five calendar years (August 10, 1990 to August 9, 1995) and the other for the most recent twelve-month period (August 10, 1994 to August 9, 1995). The five-year analysis gives an average level of activity for that period for comparison to the more recent activity.

Because most inspections focus on single-media requirements, the data queries presented in this section are taken from single media databases. These databases do not provide data on whether inspections are state/local or EPA-led. However, the table breaking down the universe of violations does give the reader a crude measurement of the EPA's and states' efforts within each media program. The presented data illustrate the variations across regions for certain sectors.<sup>c</sup> This variation may be attributable to state/local data entry variations, specific geographic concentrations, proximity to population centers, sensitive ecosystems, highly toxic chemicals used in production, or historical noncompliance. Hence, the exhibited data do not rank regional performance or necessarily reflect which regions may have the most compliance problems.

## Compliance and Enforcement Data Definitions

### General Definitions

**Facility Indexing System (FINDS)** -- this system assigns a common facility number to EPA single-media permit records. The FINDS identification number allows EPA to compile and review all permit, compliance, enforcement and pollutant release data for any given regulated facility.

**Integrated Data for Enforcement Analysis (IDEA)** -- is a data integration system that can retrieve information from the major EPA program office databases. IDEA uses the FINDS identification number to "glue together"

---

<sup>c</sup> EPA Regions include the following states: I (CT, MA, ME, RI, NH, VT); II (NJ, NY, PR, VI); III (DC, DE, MD, PA, VA, WV); IV (AL, FL, GA, KY, MS, NC, SC, TN); V (IL, IN, MI, MN, OH, WI); VI (AR, LA, NM, OK, TX); VII (IA, KS, MO, NE); VIII (CO, MT, ND, SD, UT, WY); IX (AZ, CA, HI, NV, Pacific Trust Territories); X (AK, ID, OR, WA).

separate data records from EPA's databases. This is done to create a "master list" of data records for any given facility. Some of the data systems accessible through IDEA are: AIRS (Air Facility Indexing and Retrieval System, Office of Air and Radiation), PCS (Permit Compliance System, Office of Water), RCRIS (Resource Conservation and Recovery Information System, Office of Solid Waste), NCDB (National Compliance Data Base, Office of Prevention, Pesticides, and Toxic Substances), CERCLIS (Comprehensive Environmental and Liability Information System, Superfund), and TRIS (Toxic Release Inventory System). IDEA also contains information from outside sources such as Dun and Bradstreet and the Occupational Safety and Health Administration (OSHA). Most data queries displayed in notebook sections IV and VII were conducted using IDEA.

### Data Table Column Heading Definitions

**Facilities in Search** -- are based on the universe of TRI reporters within the listed SIC code range. For industries not covered under TRI reporting requirements, the notebook uses the FINDS universe for executing data queries. The SIC code range selected for each search is defined by each notebook's selected SIC code coverage described in Section II.

**Facilities Inspected** -- indicates the level of EPA and state agency facility inspections for the facilities in this data search. These values show what percentage of the facility universe is inspected in a 12 or 60 month period. This column does not count non-inspectional compliance activities such as the review of facility-reported discharge reports.

**Number of Inspections** -- measures the total number of inspections conducted in this sector. An inspection event is counted each time it is entered into a single media database.

**Average Time Between Inspections** -- provides an average length of time, expressed in months, that a compliance inspection occurs at a facility within the defined universe.

**Facilities with One or More Enforcement Actions** -- expresses the number of facilities that were party to at least one enforcement action within the defined time period. This category is broken down further into federal and state actions. Data are obtained for administrative, civil/judicial, and criminal enforcement actions. Administrative actions include Notices of Violation (NOVs). A facility with multiple enforcement actions is only counted once in this column (facility with three enforcement actions counts as one). All percentages that appear are referenced to the number of facilities inspected.

**Total Enforcement Actions** -- describes the total number of enforcement actions identified for an industrial sector across all environmental statutes. A facility with multiple enforcement actions is counted multiple times (a facility with three enforcement actions counts as three).

**State Lead Actions** -- shows what percentage of the total enforcement actions are taken by state and local environmental agencies. Varying levels of use by states of EPA data systems may limit the volume of actions accorded state enforcement activity. Some states extensively report enforcement activities into EPA data systems, while other states may use their own data systems.

**Federal Lead Actions** -- shows what percentage of the total enforcement actions are taken by the United States Environmental Protection Agency. This value includes referrals from state agencies. Many of these actions result from coordinated or joint state/federal efforts.

**Enforcement to Inspection Rate** -- expresses how often enforcement actions result from inspections. This value is a ratio of enforcement actions to inspections and is presented for comparative purposes only. This measure is a rough indicator of the relationship between inspections and enforcement. This measure simply indicates historically how many enforcement actions can be attributed to inspection activity. Reported inspections and enforcement actions under the Clean Water Act (CWA), the Clean Air Act (CAA) and the Resource Conservation and Recovery Act (RCRA) are included in this ratio. Inspections and actions from the TSCA/FIFRA/EPCRA database are not factored into this ratio because most of the actions taken under these programs are not the result of facility inspections. This ratio does not account for enforcement actions arising from non-inspection compliance monitoring activities (e.g., self-reported water discharges) that can result in enforcement action within the CAA, CWA and RCRA.

**Facilities with One or More Violations Identified** -- indicates the number and percentage of inspected facilities having a violation identified in one of the following data categories: In Violation or Significant Violation Status (CAA); Reportable Noncompliance, Current Year Noncompliance, Significant Noncompliance (CWA); Noncompliance and Significant Noncompliance (FIFRA, TSCA, and EPCRA); Unresolved Violation and Unresolved High Priority Violation (RCRA). The values presented for this column reflect the extent of noncompliance within the measured time frame, but do not distinguish between the severity of the noncompliance. Percentages within this column can exceed 100 percent because facilities can be in violation status without being inspected. Violation status may be a precursor to an enforcement action, but does not necessarily indicate that an enforcement action will occur.

**Media Breakdown of Enforcement Actions and Inspections** -- four columns identify the proportion of total inspections and enforcement actions within EPA Air, Water, Waste, and TSCA/FIFRA/EPCRA databases. Each column is a percentage of either the "Total Inspections," or the "Total Actions" column.

### VII.A. Petroleum Refining Compliance History

Exhibit 24 provides an overview of the reported compliance and enforcement data for the refining industry over the past five years (August 1990 to August 1995). These data are also broken out by EPA Region thereby permitting geographical comparisons. A few points evident from the data are listed below.

- Almost all of the facilities identified in the database search were inspected in the past five years. These facilities were inspected on average every three months.
- The ratio of enforcement actions to inspections varied widely between Regions over the past five years with little or no direct correlation to the number of facilities in the Region or the proportion of state lead versus federal lead actions.
- Those facilities with one or more enforcement actions had, on average, over the five year period, almost eight enforcement actions brought against them.

<b>Exhibit 24: Five-Year Enforcement and Compliance Summary for Petroleum Refining</b>									
<b>A</b>	<b>B</b>	<b>C</b>	<b>D</b>	<b>E</b>	<b>F</b>	<b>G</b>	<b>H</b>	<b>I</b>	<b>J</b>
<b>Region</b>	<b>Facilities in Search</b>	<b>Facilities Inspected</b>	<b>Number of Inspections</b>	<b>Average Months Between Inspections</b>	<b>Facilities with 1 or More Enforcement Actions</b>	<b>Total Enforcement Actions</b>	<b>Percent State Lead Actions</b>	<b>Percent Federal Lead Actions</b>	<b>Enforcement to Inspection Rate</b>
I	0	0	0	--	0	0	--	--	--
II	8	8	242	2	8	71	55%	45%	0.29
III	12	12	422	2	10	101	85%	15%	0.24
IV	14	13	242	3	4	32	77%	23%	0.09
V	17	17	353	3	10	46	67%	33%	0.13
VI	45	42	869	3	36	269	69%	31%	0.31
VII	5	5	172	2	5	26	8%	92%	0.15
VIII	16	15	535	2	13	118	73%	27%	0.22
IX	28	23	286	6	19	116	55%	45%	0.41
X	11	10	116	6	5	28	64%	36%	0.24
<b>TOTAL</b>	<b>156</b>	<b>145</b>	<b>3,257</b>	<b>3</b>	<b>110</b>	<b>797</b>	<b>66%</b>	<b>34%</b>	<b>0.25</b>

**VII.B. Comparison of Enforcement Activity Between Selected Industries**

Exhibits 25 and 26 allow the compliance history of the petroleum refining sector to be compared to the other industries covered by the industry sector notebooks. Comparisons between Exhibits 25 and 26 permit the identification of trends in compliance and enforcement records of the industry by comparing data covering the last five years to that of the past year. Some points evident from the data are listed below.

- Of those sectors listed, the petroleum refining industry has been the most frequently inspected industry over the past five years.
- The industry has a relatively large proportion of facilities with violations and enforcement actions, in comparison to the other sectors.
- The rate of enforcement actions per inspection for the industry is relatively high, and has changed little over the past year.

Exhibits 27 and 28 provide a more in-depth comparison between petroleum refining industry and other sectors by breaking out the compliance and enforcement data by environmental statute. As in the previous Exhibits (Exhibits 25 and 26), the data cover the last five years (Exhibit 27) and the last one year (Exhibit 28) to facilitate the identification of recent trends. A few points evident from the data are listed below.

- The number of inspections carried out under each environmental statute as a percent of the total has changed little between the average of the past five years and that of the past year. Inspections under CAA appear to be slightly more frequent while inspections under RCRA appear to be slightly less frequent.
- The distribution of enforcement actions between statutes has also changed very little between the past five years and one year. Enforcement actions under RCRA decreased slightly while enforcement actions under CWA have increased slightly.

### Exhibit 25: Five-Year Enforcement and Compliance Summary for Selected Industries

A	B	C	D	E	F	G	H	I	J
Industry Sector	Facilities in Search	Facilities Inspected	Number of Inspections	Average Months Between Inspections	Facilities with 1 or More Enforcement Actions	Total Enforcement Actions	Percent State Lead Actions	Percent Federal Lead Actions	Enforcement to Inspection Rate
Pulp and Paper	306	265	3,766	5	115	502	78%	22%	0.13
Printing	4,106	1,035	4,723	52	176	514	85%	15%	0.11
Inorganic Chemicals	548	298	3,034	11	99	402	76%	24%	0.13
Organic Chemicals	412	316	3,864	6	152	726	66%	34%	0.19
<b>Petroleum Refining</b>	<b>156</b>	<b>145</b>	<b>3,257</b>	<b>3</b>	<b>110</b>	<b>797</b>	<b>66%</b>	<b>34%</b>	<b>0.25</b>
Iron and Steel	374	275	3,555	6	115	499	72%	28%	0.14
Dry Cleaning	933	245	633	88	29	103	99%	1%	0.16
Metal Mining	873	339	1,519	34	67	155	47%	53%	0.10
Non-Metallic Mineral Mining	1,143	631	3,422	20	84	192	76%	24%	0.06
Lumber and Wood	464	301	1,891	15	78	232	79%	21%	0.12
Furniture	293	213	1,534	11	34	91	91%	9%	0.06
Rubber and Plastic	1,665	739	3,386	30	146	391	78%	22%	0.12
Stone, Clay, and Glass	468	268	2,475	11	73	301	70%	30%	0.12
Fabricated Metal	2,346	1,340	5,509	26	280	840	80%	20%	0.15
Nonferrous Metal	844	474	3,097	16	145	470	76%	24%	0.15
Electronics	405	222	777	31	68	212	79%	21%	0.27
Automobiles	598	390	2,216	16	81	240	80%	20%	0.11

### Exhibit 26: One-Year Inspection and Enforcement Summary for Selected Industries

A Industry Sector	B Facilities in Search	C Facilities Inspected	D Number of Inspections	E Facilities with 1 or More Violations		F Facilities with 1 or more Enforcement Actions		G Total Enforcement Actions	H Enforcement to Inspection Rate
				Number	Percent*	Number	Percent*		
Pulp and Paper	306	189	576	162	86%	28	15%	88	0.15
Printing	4,106	397	676	251	63%	25	6%	72	0.11
Inorganic Chemicals	548	158	427	167	106%	19	12%	49	0.12
Organic Chemicals	412	195	545	197	101%	39	20%	118	0.22
<b>Petroleum Refining</b>	<b>156</b>	<b>109</b>	<b>437</b>	<b>109</b>	<b>100%</b>	<b>39</b>	<b>36%</b>	<b>114</b>	<b>0.26</b>
Iron and Steel	374	167	488	165	99%	20	12%	46	0.09
Dry Cleaning	933	80	111	21	26%	5	6%	11	0.10
Metal Mining	873	114	194	82	72%	16	14%	24	0.13
Non-metallic Mineral Mining	1,143	253	425	75	30%	28	11%	54	0.13
Lumber and Wood	464	142	268	109	77%	18	13%	42	0.58
Furniture	293	160	113	66	41%	3	2%	5	0.55
Rubber and Plastic	1,665	271	435	289	107%	19	7%	59	0.14
Stone, Clay, and Glass	468	146	330	116	79%	20	14%	66	0.20
Nonferrous Metals	844	202	402	282	140%	22	11%	72	0.18
Fabricated Metal	2,346	477	746	525	110%	46	10%	114	0.15
Electronics	405	60	87	80	133%	8	13%	21	0.24
Automobiles	598	169	284	162	96%	14	8%	28	0.10

\* Percentages in Columns E and F are based on the number of facilities inspected (Column C). Percentages can exceed 100% because violations and actions can occur without a facility inspection.

### Exhibit 27: Five-Year Inspection and Enforcement Summary by Statute for Selected Industries

Industry Sector	Facilities Inspected	Total Inspections	Total Enforcement Actions	Clean Air Act		Clean Water Act		Resource Conservation and Recovery Act		FIFRA/TSCA/EPCRA/Other	
				% of Total Inspections	% of Total Actions	% of Total Inspections	% of Total Actions	% of Total Inspections	% of Total Actions	% of Total Inspections	% of Total Actions
Pulp and Paper	265	3,766	502	51%	48%	38%	30%	9%	18%	2%	3%
Printing	1,035	4,723	514	49%	31%	6%	3%	43%	62%	2%	4%
Inorganic Chemicals	298	3,034	402	29%	26%	29%	17%	39%	53%	3%	4%
Organic Chemicals	316	3,864	726	33%	30%	16%	21%	46%	44%	5%	5%
<b>Petroleum Refining</b>	<b>145</b>	<b>3,237</b>	<b>797</b>	<b>44%</b>	<b>32%</b>	<b>19%</b>	<b>12%</b>	<b>35%</b>	<b>52%</b>	<b>2%</b>	<b>5%</b>
Iron and Steel	275	3,555	499	32%	20%	30%	18%	37%	58%	2%	5%
Dry Cleaning	245	633	103	15%	1%	3%	4%	83%	93%	0%	1%
Metal Mining	339	1,519	155	35%	17%	57%	60%	6%	14%	1%	9%
Non-metallic Mineral Mining	631	3,422	192	65%	46%	31%	24%	3%	27%	0%	4%
Lumber and Wood	301	1,891	232	31%	21%	8%	7%	59%	67%	2%	5%
Furniture	293	1,534	91	52%	27%	1%	1%	45%	64%	1%	8%
Rubber and Plastic	739	3,386	391	39%	15%	13%	7%	44%	68%	3%	10%
Stone, Clay, and Glass	268	2,475	301	45%	39%	15%	5%	39%	51%	2%	5%
Nonferrous Metals	474	3,097	470	36%	22%	22%	13%	38%	54%	4%	10%
Fabricated Metal	1,340	5,509	840	25%	11%	15%	6%	56%	76%	4%	7%
Electronics	222	777	212	16%	2%	14%	3%	66%	90%	3%	5%
Automobiles	390	2,216	240	35%	15%	9%	4%	54%	75%	2%	6%

**Exhibit 28: One-Year Inspection and Enforcement Summary by Statute for Selected Industries**

Industry Sector	Facilities Inspected	Total Inspections	Total Enforcement Actions	Clean Air Act		Clean Water Act		Resource Conservation and Recovery Act		FIFRA/TSCA/EPCRA/Other	
				% of Total Inspections	% of Total Actions	% of Total Inspections	% of Total Actions	% of Total Inspections	% of Total Actions	% of Total Inspections	% of Total Actions
Pulp and Paper	189	576	88	56%	69%	35%	21%	10%	7%	0%	3%
Printing	397	676	72	50%	27%	5%	3%	44%	66%	0%	4%
Inorganic Chemicals	158	427	49	26%	38%	29%	21%	45%	36%	0%	6%
Organic Chemicals	195	545	118	36%	34%	13%	16%	50%	49%	1%	1%
<b>Petroleum Refining</b>	<b>109</b>	<b>437</b>	<b>114</b>	<b>50%</b>	<b>31%</b>	<b>19%</b>	<b>16%</b>	<b>30%</b>	<b>47%</b>	<b>1%</b>	<b>6%</b>
Iron and Steel	167	488	46	29%	18%	35%	26%	36%	50%	0%	6%
Dry Cleaning	80	111	11	21%	4%	1%	22%	78%	67%	0%	7%
Metal Mining	114	194	24	47%	42%	43%	34%	10%	6%	0%	19%
Non-metallic Mineral Mining	253	425	54	69%	58%	26%	16%	5%	16%	0%	11%
Lumber and Wood	142	268	42	29%	20%	8%	13%	63%	61%	0%	6%
Furniture	293	160	5	58%	67%	1%	10%	41%	10%	0%	13%
Rubber and Plastic	271	435	59	39%	14%	14%	4%	46%	71%	1%	11%
Stone, Clay, and Glass	146	330	66	45%	52%	18%	8%	38%	37%	0%	3%
Nonferrous Metals	202	402	72	33%	24%	21%	3%	44%	69%	1%	4%
Fabricated Metal	477	746	114	25%	14%	14%	8%	61%	77%	0%	2%
Electronics	60	87	21	17%	2%	14%	7%	69%	87%	0%	4%
Automobiles	169	284	28	34%	16%	10%	9%	56%	69%	1%	6%

## VII.C. Review of Major Legal Actions

### Major Cases/Supplemental Environmental Projects

This section provides summary information about major cases that have affected this sector, and a list of Supplementary Environmental Projects (SEPs). SEPs are compliance agreements that reduce a facility's stipulated penalty in return for an environmental project that exceeds the value of the reduction. Often, these projects fund pollution prevention activities that can significantly reduce the future pollutant loadings of a facility.

#### VII.C.1. Review of Major Cases

Historically, OECA's Enforcement Capacity and Outreach Office does not regularly compile information related to major cases and pending litigation within an industry sector. The staff are willing to pass along such information to Agency staff as requests are made. (Office of Enforcement Capacity and Outreach 202-260-4140) In addition, summaries of completed enforcement actions are published each fiscal year in the Enforcement Accomplishments Report. To date, these summaries are not organized by industry sector. (Contact: Robert Banks, 202-260-8296)

#### VII.C.2. Supplementary Environmental Projects

Supplemental environmental projects (SEPs) are an enforcement option that requires the non-compliant facility to complete specific projects. Regional summaries of SEPs undertaken in the 1993 and 1994 federal fiscal years were reviewed. Eleven projects were undertaken that involved petroleum refineries, as shown in the following table.

In the petroleum refinery sector, no single statute engendered the majority of SEPs. Due to differences in regional descriptions, the specifics of the original violations are not known. Overall, Clean Air Act (CAA) violations were the most common amongst petroleum refineries; even so, only three out of the ten projects were due to CAA violations.

The SEPs in the petroleum refinery sector can be grouped into four categories:

- **Process change.** Two SEPs involved the discontinuation of particular crude oil units that generated regulated waste streams. Costs to companies were \$3,200,000 and \$2,000,000, respectively, the most costly of all petroleum refinery SEPs.

- **Leak prevention.** Facilities improved leak detection and prevention technologies in piping or tanks as the result of four projects. Original violations for these SEPs were RCRA, CAA, and the Oil Pollution Act (OPA). Cost to company ranged from \$265,000 to \$800,000.
- **Control technology improvement/installation.** The three CAA related original violations all had control technology improvements or installations as projects. Sulfuric air emissions ( $H_2S$ ,  $SO_2$ ) were reduced in two cases (a reduction of 274 tons/year of  $SO_2$ ) and opacity monitoring was initiated in the third case. Cost to company ranged from \$85,000 to \$270,000.
- **Non-process related projects.** Some SEPs involved projects that were not directly related to the petroleum refining process. In one case, PCB-containing transformers were removed as the result of a TSCA violation. Other cases involved equipment donations to Local Emergency Planning Commissions due to CERCLA non-reporting violations. Cost to company ranged from \$9,000 to \$19,000.

## Exhibit 29: FY-1993,1994 Supplemental Environmental Projects Overview: Petroleum Refining

General SEP Information			Violation Information					Pollutant Reduction		Project Description
FY	Company Name	State/Region	Type	Initial Penalty	Final Penalty	SEP Credit	SEP Cost to Company	Pollutant Concern	Pollutant Reduction	
93	Union Oil Company of California	AK	TSCA	\$11,000	\$9,350	\$4,675	>\$10,000	PCB	N/A	Early disposal of PCB transformers and/or PCB-contaminated transformers
93	UNOCAL	CA	N/A	\$689,000	\$200,000	\$25,000	\$2,000,000	N/A	N/A	Shut down crude unit that generated the regulated waste stream
93	Hawaiian Independent Refinery Inc.	HA	RCRA 3008(a)	\$621,200	\$500,000	\$200,000	N/A	Benzene	100%	Installed double-lining in three crude oil storage tanks and installed leak detection systems to protect groundwater from benzene leachate
93	Marathon Oil Co.	IN	CAA/NSPS Subpart J	N/A	N/A	N/A	\$265,000	Oil leakage, hydrogen sulfide	N/A	Repiping of refinery fuel gas lines, increased monitoring requirements, installation of hydrogen sulfide emission scrubber
93	Fina Oil	TX	CERCLA 103(a)	\$25,000	\$2,000	N/A	\$19,000	N/A	N/A	Donation of emergency and/or computer equipment to LEPC for response/planning for chemical emergencies, agreed to participate in LEPC activities, and to provide technical assistance
93	Amoco Oil	TX	CERCLA 103(a)	\$25,000	\$8,000	N/A	\$9,000	N/A	N/A	Donated emergency and/or computer equipment to LEPC for response/planning for chemical emergencies, participation in LEPC activities, and technical assistance
93	Indiana Refining Ltd.	Reg. V	CAA-SIP	N/A	N/A	N/A	\$85,067	Opacity	N/A	Installed opacity monitors and began compliance report submission
93	U.S. Oil & Refining	WA	OPA	N/A	\$470,000	N/A	\$800,000	Oil spill	N/A	Purchase and installation of state of the art computerized leak detection system
93	Texaco Refining and Marketing, Inc.	WA	OPA	N/A	\$500,000	N/A	\$800,000	Oil spill	N/A	Purchase and installation of state of the art computerized leak detection system
93	Sinclair Oil Corp.	WY	CAA, Sec. 113 (d)	N/A	\$105,000	\$70,000	\$270,000	SO <sub>2</sub>	274 tons/yr	SO <sub>2</sub> removal efficiency of the SRU upgraded from 88.5% to 93.5%
94	UNOCAL	CA	RCRA	N/A	N/A	\$25,000	\$3,200,000	Benzene	N/A	Decommissioning of a crude processing unit responsible for generating most of the facility's benzene contaminated wastewater

### Violation Information Terms

Initial penalty: Initial proposed cash penalty for violation

Final penalty: Total penalty after SEP negotiation

SEP credit: Cash credit given for SEP so that, Final penalty - SEP credit = Final cash penalty

SEP cost to company: Actual cost to company of SEP implementation

NOTE: Due to differences in terminology and level of detail between regional SEP information, in some cases the figure listed as Final penalty may be the Final cash penalty after deduction for SEP credit

N/A: Information not available at time of printing.

## VIII. COMPLIANCE ASSURANCE ACTIVITIES AND INITIATIVES

This section highlights the activities undertaken by this industry sector and public agencies to voluntarily improve the sector's environmental performance. These activities include those independently initiated by industrial trade associations. In this section, the notebook also contains a listing and description of national and regional trade associations.

### VIII.A. Sector-Related Environmental Programs and Activities

#### *Common Sense Initiative*

The EPA's Common Sense Initiative (CSI) was announced in November of 1993 to encourage pollution prevention in a few pilot industrial sectors including: iron and steel, electronics, metal plating and finishing, automobiles, printing, and petroleum refining. The program shifts regulatory focus from concentrating on individual pollutants and media, to industry-wide approaches to environmental problems. An EPA team has been assigned to each industry and a strategic plan will be drawn up to identify opportunities to coordinate rulemaking and to streamline record-keeping and permitting requirements. The teams are working with industry to identify innovative approaches in pollution prevention and environmental technology. Co-chairs for the Petroleum Refining Committee are Elliot Laws, Assistant Administrator for the Office of Solid Waste and Emergency Response; and Jane Saginaw, Regional Administrator - Region VI. Starting in November of 1994, meetings of most stakeholders including EPA and other government officials, industry representatives, and environmental groups, have been held to explain the Initiative and its goals as well as to exchange ideas on how to best prevent pollution in the petroleum refining industry. (Contact: Petroleum Refining Team Leaders, Meg Kelly, Office of Solid Waste and Emergency Response, 703-308-8800; Gerald Fontenot, Region VI - Air Branch, 214-665-7205; and OECA staff lead, Tom Ripp, 202-564-7003.)

#### *EPA Regional Compliance and Enforcement Activities*

A number of regions have focused on enforcement and compliance activities that affect the petroleum refining sector. Region V is currently carrying out a geographic enforcement initiative which includes the petroleum refining industry (Contact: Reg Pallesen, 312-886-0555). In addition, the EPCRA program of Region V conducts a minimum of six outreach training sessions annually, one in each state, which cover all industries. In Region VIII the NPDES Branch began an enforcement initiative aimed at petroleum refineries in FY94. The initiative addresses surface water and groundwater contamination by focusing on the prevention and elimination of future discharges. The RCRA branch of Region VIII is developing a program for FY95 that includes forming a Multi-Media Refinery Workgroup that will

integrate its activities with the Common Sense Initiative Workgroup. One of the issues to be examined by the workgroup are integrated permits for watersheds. Region IX is working with the National Enforcement Investigation Center on a multi-media petroleum refining enforcement initiative.

### VIII.B. EPA Voluntary Programs

#### *33/50 Program*

The "33/50 Program" is EPA's voluntary program to reduce toxic chemical releases and transfers of seventeen chemicals from manufacturing facilities. Participating companies pledge to reduce their toxic chemical releases and transfers by 33 percent as of 1992 and by 50 percent as of 1995 from the 1988 baseline year. Certificates of Appreciation have been given out to participants meeting their 1992 goals. The list of chemicals includes seventeen high-use chemicals reported in the Toxics Release Inventory. Exhibit 30 lists those companies participating in the 33/50 program that reported the SIC code 2911 to TRI. Many of the companies shown listed multiple SIC codes and, therefore, are likely to carry out operations in addition to petroleum refining. The SIC codes reported by each company are listed in no particular order. In addition, the number of facilities within each company that are participating in the 33/50 program and that report SIC 2911 to TRI are shown. Finally, each company's total 1993 releases and transfers of 33/50 chemicals and the percent reduction in these chemicals since 1988 are presented.

The petroleum refining industry as a whole used, generated or processed all seventeen target TRI chemicals. Of the target chemicals, benzene, toluene, xylene and methyl ethyl ketone are released and transferred most frequently and in similar quantities. These four toxic chemicals account for about 5 percent of TRI releases and transfers from petroleum refining facilities. Twenty six companies listed under SIC 2911 are currently participating in the 33/50 program. They account for 29 percent of the 91 companies carrying out petroleum refining operations, which is significantly higher than the average for all industries of 14 percent participation. Exhibit 30 also shows that within these 26 companies, 99 facilities reporting SIC 2911 are participating in the 33/50 program. This comprises about 62 percent of the petroleum refining facilities reporting to TRI. (For more information, contact: Mike Burns, 202-260-6394 or the 33/50 Program 202-260-6907)

<b>Exhibit 30: 33/50 Program Participants Reporting SIC 2911 (Petroleum Refining)</b>					
<b>Parent Company</b>	<b>City, State</b>	<b>SIC Codes Reported</b>	<b>Number of Participating Facilities</b>	<b>1993 Releases and Transfers (lbs)</b>	<b>% Reduction 1988 to 1993</b>
Amerada Hess Corporation	New York, NY	2911, 5171	4	1,286,125	50
American Petrofina Holding Co.	Dallas, TX	2911	2	747,799	40
Amoco Corporation	Chicago, IL	2911, 2951, 2992	7	4,632,163	50
Ashland Oil Inc.	Russell, KY	2911	3	723,562	50
Atlantic Richfield Company	Los Angeles, CA	2911	3	2,435,248	2
BHP Holdings (USA) Inc.	San Francisco, CA	2911	1	64,365	***
BP America Inc.	Cleveland, OH	2911	5	1,597,404	24
Chevron Corporation	San Francisco, CA	2911	11	2,794,502	50
Cibro Petroleum Bronx Inc.	Bronx, NY	2911, 5171	1	4,025	***
Citgo Petroleum Corporation	Tulsa, OK	2911	2	1,164,354	20
Clark USA Inc.	Saint Louis, MO	2911	2	33,982	***
E. I. Du Pont De Nemours & Co	Wilmington, DE	2911	4	11,740,853	50
Exxon Corporation	Irving, TX	2911, 5171	5	2,469,930	50
Kerr-McGee Corporation	Oklahoma City, OK	2911	3	374,098	35
Mobil Corporation	Fairfax, VA	2911, 2869	6	4,263,284	50
New Street Capital Corporation	Atlanta, GA	2911	1	2,544	50
Pennzoil Company	Houston, TX	2911	3	2,594,107	30
Phillips Petroleum Company	Bartlesville, OK	2911, 2819	4	2,367,877	50
Quaker State Corporation	Oil City, PA	2911, 2992	1	292,587	6
Shell Petroleum Inc.	Houston, TX	2911, 2869	6	3,240,716	55
Star Enterprise	Houston, TX	2911	5	601,640	50
Sun Company Inc.	Radnor, PA	2911	5	2,826,737	50
Texaco Inc.	White Plains, NY	2911	5	514,803	50
Unocal Corporation	Los Angeles, CA	2911	4	238,520	50
USX Corporation	Pittsburgh, PA	2911	5	1,510,772	25
Witco Corporation	New York, NY	2911	1	327,611	50
* = not quantifiable against 1988 data.					
** = use reduction goal only.					
*** = no numerical goal.					
Source: U.S. EPA, Toxics Release Inventory, 1993.					

### *Environmental Leadership Program*

The Environmental Leadership Program (ELP) is a national initiative piloted by EPA and state agencies in which facilities have volunteered to demonstrate innovative approaches to environmental management and compliance. EPA has selected 12 pilot projects at industrial facilities and federal installations which will demonstrate the principles of the ELP

program. These principles include: environmental management systems, multimedia compliance assurance, third-party verification of compliance, public measures of accountability, community involvement, and mentoring programs. In return for participating, pilot participants receive public recognition and are given a period of time to correct any violations discovered during these experimental projects. At present, no petroleum refineries are carrying out ELP pilot projects. (Contact: Tai-ming Chang, ELP Director 202-564-5081 or Robert Fentress 202-564-7023)

### *Project XL*

Project XL was initiated in March 1995 as a part of President Clinton's *Reinventing Environmental Regulation* initiative. The projects seek to achieve cost effective environmental benefits by allowing participants to replace or modify existing regulatory requirements on the condition that they produce greater environmental benefits. EPA and program participants will negotiate and sign a Final Project Agreement, detailing specific objectives that the regulated entity shall satisfy. In exchange, EPA will allow the participant a certain degree of regulatory flexibility and may seek changes in underlying regulations or statutes. Participants are encouraged to seek stakeholder support from local governments, businesses, and environmental groups. EPA hopes to implement fifty pilot projects in four categories including facilities, sectors, communities, and government agencies regulated by EPA. Applications will be accepted on a rolling basis and projects will move to implementation within six months of their selection. For additional information regarding XL Projects, including application procedures and criteria, see the May 23, 1995 Federal Register Notice. (Contact Jon Kessler at EPA's Office of Policy Analysis 202-260-4034)

### *Green Lights Program*

EPA's Green Lights program was initiated in 1991 and has the goal of preventing pollution by encouraging U.S. institutions to use energy-efficient lighting technologies. The program has over 1,500 participants which include major corporations; small and medium sized businesses; federal, state and local governments; non-profit groups; schools; universities; and health care facilities. Each participant is required to survey their facilities and upgrade lighting wherever it is profitable. EPA provides technical assistance to the participants through a decision support software package, workshops and manuals, and a financing registry. EPA's Office of Air and Radiation is responsible for operating the Green Lights Program. (Contact: Maria Tikoff at 202-233-9178 or the Green Light/Energy Star Hotline at 202-775-6650)

*WasteWi\$e Program*

The WasteWi\$e Program was started in 1994 by EPA's Office of Solid Waste and Emergency Response. The program is aimed at reducing municipal solid wastes by promoting waste minimization, recycling collection and the manufacturing and purchase of recycled products. As of 1994, the program had about 300 companies as members, including a number of major corporations. Members agree to identify and implement actions to reduce their solid wastes and must provide EPA with their waste reduction goals along with yearly progress reports. EPA in turn provides technical assistance to member companies and allows the use of the WasteWi\$e logo for promotional purposes. (Contact: Lynda Wynn 202-260-0700 or the WasteWi\$e Hotline at 800-372-9473)

*Climate Wise Recognition Program*

The Climate Change Action Plan was initiated in response to the U.S. commitment to reduce greenhouse gas emissions in accordance with the Climate Change Convention of the 1990 Earth Summit. As part of the Climate Change Action Plan, the Climate Wise Recognition Program is a partnership initiative run jointly by EPA and the Department of Energy. The program is designed to reduce greenhouse gas emissions by encouraging reductions across all sectors of the economy, encouraging participation in the full range of Climate Change Action Plan initiatives, and fostering innovation. Participants in the program are required to identify and commit to actions that reduce greenhouse gas emissions. The program, in turn, gives organizations early recognition for their reduction commitments; provides technical assistance through consulting services, workshops, and guides; and provides access to the program's centralized information system. At EPA, the program is operated by the Air and Energy Policy Division within the Office of Policy Planning and Evaluation. (Contact: Pamela Herman 202-260-4407)

*NICE<sup>3</sup>*

The U.S. Department of Energy and EPA's Office of Pollution Prevention are jointly administering a grant program called The National Industrial Competitiveness through Energy, Environment, and Economics (NICE<sup>3</sup>). By providing grants of up to 50 percent of the total project cost, the program encourages industry to reduce industrial waste at its source and become more energy-efficient and cost-competitive through waste minimization efforts. Grants are used by industry to design, test, demonstrate, and assess the feasibility of new processes and/or equipment with the potential to reduce pollution and increase energy efficiency. The program is open to all industries; however, priority is given to proposals from participants in the

pulp and paper, chemicals, primary metals, and petroleum and coal products sectors. The program has worked with the petroleum industry to evaluate the feasibility of using a closed-loop solvent extraction system to recover organic material from solid wastes normally disposed of off-site. (Contact: DOE's Golden Field Office 303-275-4729)

### VIII.C. Trade Association/Industry Sponsored Activity

#### VIII.C.1. Environmental Programs

##### *Global Environmental Management Initiative*

The Global Environmental Management Initiative (GEMI) is made up of group of leading companies dedicated to fostering environmental excellence by business. GEMI promotes a worldwide business ethic for environmental management and sustainable development, to improve the environmental performance of business through example and leadership. In 1994, GEMI's membership consisted of about 30 major corporations including Amoco Corporation.

##### *Amoco - U.S. EPA Pollution Prevention Project*

The Amoco - U.S. EPA Pollution Prevention Project was a voluntary joint project to study pollution prevention opportunities at an industrial facility. The Amoco Oil Company's refinery at Yorktown, Virginia was used to conduct a multi-media assessment of releases to the environment, then to develop and evaluate options to reduce these releases. The project identified pollutant release points and cost effective pollution prevention techniques. In addition, a number of important observations were made relating to: differences in TRI estimated releases and actual releases, regulatory obstacles to implementing pollution prevention programs, and incentives for pollution prevention. A project summary report was issued in January 1992.<sup>112</sup>

##### *API Residual Management Survey*

The American Petroleum Institute (API) has conducted yearly surveys of residual materials generation and residual management practices at refineries. The survey collects data on about 30 different waste streams, their management techniques and pollution prevention activities of API members. A yearly report is issued titled, "Generation and Management of Residual Materials." This report is available from the American Petroleum Institute.

*API Groundwater Research Program*

API conducts research to assist the petroleum industry in dealing with its groundwater contamination problems. The research is aimed at the problems faced by the petroleum industry, including petroleum refineries, but is made available to those outside the industry as well. Research studies evaluate techniques and develop new methods to detect, monitor and cleanup groundwater contamination. Numerous manuals and reports have been published and periodic conferences and workshops on groundwater monitoring and cleanup techniques are sponsored.

*Compendium of Waste Minimization Practices*

The American Petroleum Institute sponsored a waste minimization practices compendium in the Summer of 1990 to summarize waste minimization techniques for oil and gas exploration and production, refining and marketing industries. The compendium contains a literature survey and case studies.

*Petroleum Environmental Research Forum*

The Petroleum Environmental Research Forum is an industry group that shares research costs and findings that relate particularly to the petroleum industry. The Forum has funded research on pollution prevention in the industry.

*API STEP Program*

The STEP (Strategies for Today's Environmental Partnership) program was developed by API member companies to address public environmental concerns by improving the industry's environmental, health, and safety performance; documenting performance improvements; and communicating them to the public. The foundation for STEP is the API Environmental Mission and the API Guiding Environmental Principles. The program also includes a series of environmental strategic plans; a review and revision of existing industry standards; documentation of industry environmental, health, and safety performance; and mechanisms for obtaining public input. In 1992, API endorsed, as part of STEP, adoption of management practices as an API recommended practice. The management practices contain the following elements: pollution prevention, operating and process safety, community awareness, crisis readiness, product stewardship, proactive government interaction, and resource conservation. The management practices are an outline of actions to help companies incorporate environmental health and safety concerns into their planning and decision making. Each company will make its own decisions on how and whether to

change its operations. API has developed a compilation of resources that provide recommendations and guidance on various operational areas of the oil industry to assist API members with their implementation of the management practices. (Contact: Walter Retzch, API, 202-682-8598)

### VIII.C.2. Summary of Trade Associations

The trade and professional organizations serving the petroleum refining industry are either specific to petroleum refining or to the petroleum production, refining and distribution as a whole. Further differences in membership are based on company size and ownership. More specifically, the large, multinational oil companies are members of industry-wide trade groups and the small, independent petroleum refiners are members of both industry-wide and small, independent trade groups. The major trade organizations are discussed below.

#### American Petroleum Institute

1220 L St. NW  
Washington, DC 20005  
Phone: (202) 682-8000  
Fax: (202) 682-8030

Members: 300  
Staff: 400  
Contact: Alison Kerester

The American Petroleum Institute (API) is the largest trade group for the petroleum refining industry, with the largest membership and budget. API represents the major oil companies, and independent oil producers, refiners, marketers, and transporters of crude oil, lubricating oil, gasoline, and natural gas. API conducts and promotes research in the petroleum industry and collects data and publishes statistical reports on oil production and refining. Numerous manuals, booklets, and other materials are published on petroleum refining to assist members in environmental compliance.

#### National Petroleum Refiners Association

1899 L St. NW 1000  
Washington, DC 20036  
Phone: (202) 457-0480  
Fax: (202) 457-0486

Members: 370  
Staff: 28  
Contact: Norbert Dee, Ph.D.

The National Petroleum Refiners Association (NPRA) was founded in 1902 and represents virtually all domestic refiners and petrochemical manufacturers using processes similar to refineries. NPRA's membership includes both large companies and many small and independent companies.

Mid-Continent Oil and Gas Association  
801 Pennsylvania Ave. NW  
Suite 840  
Washington, DC 20004  
Phone: (202) 638-4400  
Fax: (202) 638-5967

Members: 7500  
Staff: 6  
Contact: Mr. Modiano

The Mid-Continent Oil and Gas Association was founded in 1917 and represents oil and gas producers, royalty owners, refiners, gasoline manufacturers, transporters, drilling contractors, supply and equipment dealers and wholesalers, bankers, and other individuals interested in oil business.

American Independent  
Refiners Association/  
Western Independent  
Refiners Association  
801 S. Grand Ave., 10th Fl.  
Los Angeles, CA 90017  
Phone: (213) 624-8407

Members: AIRA: 27, WIRA: 9  
Contact: Craig Moyer

The American Independent Refiners Association (AIRA) was founded in 1983 and represents independent oil refiners and companies that supply services to the independent refining industry. The Western Independent Refiners Association (WIRA) was founded later to address the specific needs of refiners on the west coast. The associations are separate, but closely affiliated with many of the members of WIRA also members of AIRA. Neither organization has a full-time staff. Much of the associations' activities are carried out by members and outside consultants. Through the associations' cooperative environmental services, members are each responsible for a federal or state agency and/or office, monitoring the environmental issues, and reporting to members. Outside consultants are hired to look at safety and environmental compliance issues.

Western States Petroleum Association  
505 N. Brand Blvd., Ste. 1400  
Glendale, CA 91203  
Phone: (818) 545-4105

Members: 60

The Western States Petroleum Association was founded in 1917 and represents oil and gas producers, royalty owners, refiners, gasoline manufacturers, transporters, drilling contractors, supply and equipment dealers and wholesalers, bankers, and other individuals interested in the oil business.

IX. CONTACTS/ACKNOWLEDGMENTS/RESOURCE MATERIALS/BIBLIOGRAPHY<sup>f</sup>

For further information on selected topics within the petroleum refining industry a list of contacts and publications are provided below:

**Contacts**

Name	Organization	Telephone	Subject
Tom Ripp	EPA/OECA	(202) 564-7003	Regulatory requirements and compliance assistance
Ken Garing	EPA/NEIC	(303) 236-3636	Industrial processes and regulatory requirements (Air)
Linda Tekrony	EPA/NEIC	(303) 236-3636	Industrial processes and regulatory requirements (RCRA)
Jim Durham	EPA/OAR	(919) 546-5672	Regulatory requirements (Air)
Ron Kirby	EPA/OW	(202) 260-7168	Regulatory requirements (Water)
Max Diaz	EPA/OSWER	(202) 260-4786	Regulatory requirements (Solid waste)
Meg Kelly	EPA/OSWER	(703) 308-8748	CSI lead - Source reduction
Katherine Keith	EPA/Region V	(312) 353-6956	Inspections, regulatory requirements (Air), and enforcement
Ken Cooper	EPA/Region VI	(713) 983-2148	Inspections and regulatory requirements (Water, RCRA and TSCA)
John Kim	EPA/Region IX	(415) 744-1263	Inspections and regulatory requirements (Air)
Paul Boys	EPA/Region X	(206) 553-1567	Inspections and regulatory requirements (Air)
Gregory Filas	DOE/EIA	(202) 586-1347	Industry financial information
Nancy Johnson	DOE/OFE	(202) 586-6458	Environmental issues
Alison Kerester	API	(202) 682-8346	Federal environmental requirements
Norbert Dee, Ph.D.	NPRA	(202) 457-0480	Federal environmental requirements

OECA: Office of Enforcement and Compliance Assistance

NEIC: National Enforcement Investigations Center

OAR: Office of Air and Radiation

OW: Office of Water

OSWER: Office of Solid Waste and Emergency Response

EIA: Energy Information Administration

OFE: Office of Fossil Energy

API: American Petroleum Institute

NPRA: National Petroleum Refiners Association

<sup>f</sup> Many of the contacts listed above have provided valuable background information and comments during the development of this document. EPA appreciates this support and acknowledges that the individuals listed do not necessarily endorse all statements made within this notebook.

---

**General Profile**

---

*The U.S. Petroleum Industry: Past as Prologue, 1970-1992*, Energy Information Administration, September, 1993. (DOE/EIA-0572)

*Petroleum: An Energy Profile*, Energy Information Administration, August, 1991. (DOE/EIA-0545(91))

*U.S. Industrial Outlook 1994*, Department of Commerce.

*1992 Census of Manufacturers Preliminary Report Industry Series: Petroleum and Coal Products*, Bureau of the Census, June 1994. (MC92-1-29A(P))

---

**Process Descriptions**

---

*Petroleum Refining - Technology & Economics*, Gary & Handwerk, 3rd Edition, Marcel Dekker, Inc., New York, N.Y., 1994.

*Petroleum Refining for the Non-Technical Person*, 2nd ed., William L. Leffler, PennWell Publishing Company, Tulsa, Oklahoma, 1985.

*Handbook of Petroleum Refining Processes*, Meyers, R.A., McGraw-Hill Book Company, New York, 1986.

*Petroleum Refining Distillation*, Watkins, R.N., Gulf Publishing, Inc., Houston, TX, 1979.

*Petroleum Refinery Enforcement Manual*, U.S. EPA Office of Enforcement, by PEDCo Environmental Inc., Arlington, Texas, March 1980. EPA-340/1-80-008.

---

**Release Profiles**

---

*Compilation of Air Pollutant Emission Factors*, 3rd ed., Ch. 9, William M. Vatauvuk, August 1977.

*Assessment of Atmospheric Emissions from Petroleum Refining*, R.G. Wetherold, Radian Corporation, Austin, Texas and U.S. EPA, Office of Research and Development, Washington, DC, April, 1980. (EPA-600/2-80-075e)

*Petroleum Industry Environmental Performance, Third Annual Report*, American Petroleum Institute, Washington, DC, 1995.

*Petroleum Refinery Enforcement Manual*, U.S. EPA Office of Enforcement, by PEDCo Environmental Inc., Arlington, Texas, March 1980. EPA-340/1-80-008.

*Hazardous Waste Generation: 1. Petroleum Refining*, U.S. EPA, Office of Solid Waste, January 1994.

*Amoco - U.S. EPA Pollution Prevention Project, Yorktown, Virginia, Project Summary*, U.S. EPA, January 1992.

*The Generation and Management of Wastes and Secondary Materials in the Petroleum Refining Industry: 1987-1988*, American Petroleum Institute, February 1991. (API Pub. no. 4530)

*Generation and Management of Wastes and Secondary Materials: Petroleum Refining Performance, 1989 Survey*, American Petroleum Institute, June 1992. (API Pub. no. 303)

*Generation and Management of Wastes and Secondary Materials: Petroleum Refining Performance, 1990 Survey*, American Petroleum Institute, August 1993. (API Pub. no. 324)

*Generation and Management of Wastes and Secondary Materials: Petroleum Refining Performance, 1991 Survey*, American Petroleum Institute, May 1994. (API Pub. no. 329)

*Toxics Release Inventory, Public Data Release, 1992*, U.S. EPA, Office of Pollution Prevention and Toxics, April, 1994. (EPA 745-R-94-001)

*Dioxin and Furans - A Primer: What They Are and How to Measure Them*, American Petroleum Institute, Washington, DC, March 1990.

*Refinery Wastewater Priority Pollutant Study - Sample Analysis and Evaluation of Data*, American Petroleum Institute, Washington, DC, December 1981.

*Environmental Design Considerations for Petroleum Refining Crude Processing Units*, American Petroleum Institute, February 1993. (API Pub. no. 311)

### **Pollution Prevention**

---

*Hazardous Waste Minimization: Part V Waste Minimization in the Petroleum Industry*, Leeman, J.E., JAPCA 38, no. 6, June 1988.

*Waste Minimization in the Petroleum Industry a Compendium of Practices*, American Petroleum Institute, November 1991. (API Pub. no. 3020)

*Amoco - U.S. EPA Pollution Prevention Project, Yorktown, Virginia, Project Summary*, U.S. EPA, January 1992.

*Case Study: Identifying Pollution Prevention Options For a Petroleum Refinery*, Balik, J.A., and Koraido, S.M., Pollution Prevention Review, Summer 1991.

*New Catalyst Designs Meet Environmental Challenges of the 1990's*, Corbgett, R.E., Oil & Gas Journal, October 1, 1990.

*Dry Scrubber Reduces SO<sub>2</sub> in Calciner Flue Gas*, Brown, G.W., Roderick, D., and Nastri, A., Oil & Gas Journal, February 18, 1991.

*Innovative Improvements Highlight FCC's Past and Future*, Avidan, A.A., Edwards, M., Owen, H., Oil & Gas Journal, January 8, 1990.

*Pollution Prevention: Strategies for Petroleum Refining* (Fact Sheet), Center for Hazardous Materials Research (CHMR), Pittsburgh, PA.

*Pollution Prevention Opportunities in Petroleum Refining* (Fact Sheet), U.S. EPA Region III, Philadelphia, PA, October, 1990.

*Pollution Prevention Opportunities Checklists*, County Sanitation Districts of Los Angeles County, January 1991.

### **Regulatory Profile**

---

*Sustainable Environmental Law*, Environmental Law Institute, West Publishing Co., St. Paul, Minn., 1993.

*Issues Affecting the Refining Sector of the Petroleum Industry, Hearings Before the Committee on Energy and Natural Resources, United States Senate, Washington, DC, May 19, 1992, Cheyenne, WY, May 28, 1992*, U.S. GPO, Washington, DC, 1992.

*Costs to the Petroleum Industry of Major New and Future Federal Government Environmental Requirements*, American Petroleum Institute, Washington, DC, October 1993. (API Discussion Paper #070R)

*U.S. Petroleum Refining: Meeting Requirements for Cleaner Fuels and Refineries, Volumes I-VI*, National Petroleum Council Committee on Refining, U.S. Department of Energy, August 1993.

*U.S. Petroleum Strategies in the Decade of the Environment*, Williams, Bob, Penn Well Books, Tulsa, OK, 1991.

*Environmental Related Issues Taking Their Turn in Restructuring Industry*, Williams, Bob, Oil & Gas Journal, January 22, 1990.

*Clean Air Act Complicates Refinery Planning*, Scherr, R.C., Smalley, G.A., and Norman, M.E., Oil & Gas Journal, May 27, 1991.

*Clean Air Amendments Put Big Burden on Refinery Planners*, Scherr, R.C., Smalley, G.A., and Norman, M.E., Oil & Gas Journal, June 10, 1991.

*U.S. Regs Cause Refiners to Rethink Wastewater Systems*, Norman, M.E., Kapoor, S., Smalley, G.A., and Daniel, B.M., Oil & Gas Journal, June 1, 1992.

*U.S. Refiners Choosing Variety of Routes to Produce Clean Fuels*, Ragsdale, R., Oil & Gas Journal, March 21, 1994.

GPO Document Ordering Form (insert blank page)

Inside Back Cover (insert blank page)

Back cover will be provided by EPA

Please note: endnotes print at end of document. They need to be manually inserted before Appendices.

## END NOTES

1. *1992 Census of Manufacturers Preliminary Report Industry Series: Petroleum and Coal Products*, Bureau of the Census, June 1994. (MC92-I-29A(P))
2. *Petroleum: An Energy Profile*, Energy Information Administration, August, 1991. (DOE/EIA-0545(91), p. 5.
3. *Petroleum Refining for the Non-Technical Person*, 2nd ed., William L. Leffler, PennWell Publishing Company, Tulsa, Oklahoma, 1985.
4. *Petroleum: An Energy Profile*, Energy Information Administration, August, 1991. (DOE/EIA-0545(91))
5. Standard Industrial Classification Manual.
6. *United States Refining Capacity*. Washington, D.C.: National Petroleum Refinery Association, January 1, 1994.
7. *1992 Census of Manufacturers Industry Series: Petroleum and Coal Products*, Bureau of the Census, June 1994. (MC92-I-29A)
8. Ibid.
9. *1992 Census of Manufacturers Industry Series: Blast Furnaces, Steel Works, and Rolling and Finishing Mills*. Bureau of the Census, May 1994. (MC92-I-29A)
10. *1992 Census of Manufacturers Industry Series: Petroleum and Coal Products*. Bureau of Census, 1987 (MC92-I-29A).
11. *United States Refinery Capacity*. Washington, D.C.: National Petroleum Refinery Association, January 1, 1994.
12. *The U.S. Petroleum Industry: Past as Prologue, 1970-1992*, Energy Information Administration, September, 1993. (DOE/EIA-0572)
13. *U.S. Industrial Outlook 1994*, Department of Commerce.
14. Ibid.
15. API comments on draft document.
16. Statement of the American Petroleum Institute.
17. Statement of the American Petroleum Institute, Issues Affecting the Refining Sector of the Petroleum Industry, Hearings Before the Committee on Energy and Natural Resources, United States Senate, Washington, DC, May 19 and 28, 1992, U.S. Government Printing Office,

Washington, DC: 1992.

18. *U.S. Industrial Outlook 1994*, Department of Commerce.
19. *U.S. Industrial Outlook 1994*, Department of Commerce.
20. Lichtblau, John H., Petroleum Industry Research Foundation, Inc., New York, NY. Prepared statement for the Hearings before the Committee on Energy and Natural Resources, United States Senate, One Hundred Second Congress, Second Session, on the Issues Affecting the Refining Sector of the Petroleum Industry, Washington, DC, May 19, 1992. U.S. Government Printing Office, Washington: 1992. ISBN 0-16-039466-X.
21. *Petroleum Refining - Technology & Economics*, Gary & Handwerk, 3rd Edition, Marcel Dekker, Inc., New York, N.Y., 1994.
22. Ibid.
23. Ibid.
24. U.S. EPA. *Development Document for Effluent Limitation Guidelines: New Source Performance Standards and Pretreatment Standards for the Petroleum Refining Point Source Category*. Ruddy, D., Project Officer, Office of Water Regulations and Standards, Washington, D.C.: U.S. EPA, October 1982.
25. *Petroleum Refining - Technology & Economics*, Gary & Handwerk, 3rd Edition, Marcel Dekker, Inc., New York, N.Y., 1994.
26. *Assessment of Atmospheric Emissions from Petroleum Refining*, R.G. Wetherold, Radian Corporation, Austin, Texas and U.S. EPA, Office of Research and Development, Washington, DC, April, 1980. (EPA-600/2-80-075e)
27. U.S. EPA. *Development Document for Effluent Limitation Guidelines: New Source Performance Standards and Pretreatment Standards for the Petroleum Refining Point Source Category*. Ruddy, D., Project Officer, Office of Water Regulations and Standards, Washington, D.C.: U.S. EPA, October 1982.
28. *Petroleum Refining for the Non-Technical Person*, 2nd ed., William L. Leffler, PennWell Publishing Company, Tulsa, Oklahoma, 1985.
29. *Assessment of Atmospheric Emissions from Petroleum Refining*, R.G. Wetherold, Radian Corporation, Austin, Texas and U.S. EPA, Office of Research and Development, Washington, DC, April, 1980. (EPA-600/2-80-075e)
30. U.S. EPA. *Development Document for Effluent Limitation Guidelines: New Source Performance Standards and Pretreatment Standards for the Petroleum Refining Point Source Category*. Ruddy, D., Project Officer, Office of Water Regulations and Standards, Washington,

D.C.: U.S. EPA, October 1982.

31. *Petroleum Refining - Technology & Economics*, Gary & Handwerk, 3rd Edition, Marcel Dekker, Inc., New York, N.Y., 1994.

32. *Petroleum Refining for the Non-Technical Person*, 2nd ed., William L. Leffler, PennWell Publishing Company, Tulsa, Oklahoma, 1985.

33. *Petroleum Refining - Technology & Economics*, Gary & Handwerk, 3rd Edition, Marcel Dekker, Inc., New York, N.Y., 1994.

34. Ibid.

35. Ibid.

36. *Petroleum Refinery Enforcement Manual*, U.S. EPA Office of Enforcement, by PEDCo Environmental Inc., Arlington, Texas, March 1980. EPA-340/1-80-008.

37. *Petroleum Refining - Technology & Economics*, Gary & Handwerk, 3rd Edition, Marcel Dekker, Inc., New York, N.Y., 1994.

38. U.S. EPA. *Development Document for Effluent Limitation Guidelines: New Source Performance Standards and Pretreatment Standards for the Petroleum Refining Point Source Category*. Ruddy, D., Project Officer, Office of Water Regulations and Standards, Washington, D.C.: U.S. EPA, October 1982.

39. *Petroleum Refining - Technology & Economics*, Gary & Handwerk, 3rd Edition, Marcel Dekker, Inc., New York, N.Y., 1994.

40. Ibid.

41. *Petroleum Refinery Enforcement Manual*, U.S. EPA Office of Enforcement, by PEDCo Environmental Inc., Arlington, Texas, March 1980. EPA-340/1-80-008.

42. *Petroleum Refining - Technology & Economics*, Gary & Handwerk, 3rd Edition, Marcel Dekker, Inc., New York, N.Y., 1994.

43. *Petroleum Refinery Enforcement Manual*, U.S. EPA Office of Enforcement, by PEDCo Environmental Inc., Arlington, Texas, March 1980. EPA-340/1-80-008.

44. *Petroleum Refining - Technology & Economics*, Gary & Handwerk, 3rd Edition, Marcel Dekker, Inc., New York, N.Y., 1994.

45. Ibid.

46. *Petroleum Refinery Enforcement Manual*, U.S. EPA Office of Enforcement, by PEDCo Environmental Inc., Arlington, Texas, March 1980. EPA-340/1-80-008.

47. U.S. EPA. *Development Document for Effluent Limitation Guidelines: New Source Performance Standards and Pretreatment Standards for the Petroleum Refining Point Source Category*. Ruddy, D., Project Officer, Office of Water Regulations and Standards, Washington, D.C.: U.S. EPA, October 1982.
48. *Petroleum Refining - Technology & Economics*, Gary & Handwerk, 3rd Edition, Marcel Dekker, Inc., New York, N.Y., 1994.
49. *Petroleum Refinery Enforcement Manual*, U.S. EPA Office of Enforcement, by PEDCo Environmental Inc., Arlington, Texas, March 1980. EPA-340/1-80-008.
50. U.S. EPA. *Development Document for Effluent Limitation Guidelines: New Source Performance Standards and Pretreatment Standards for the Petroleum Refining Point Source Category*. Ruddy, D., Project Officer, Office of Water Regulations and Standards, Washington, D.C.: U.S. EPA, October 1982.
51. *Petroleum Refining - Technology & Economics*, Gary & Handwerk, 3rd Edition, Marcel Dekker, Inc., New York, N.Y., 1994.
52. Personal interviews with EPA staff and comments on draft document by API.
53. U.S. EPA. *Development Document for Effluent Limitation Guidelines: New Source Performance Standards and Pretreatment Standards for the Petroleum Refining Point Source Category*. Ruddy, D., Project Officer, Office of Water Regulations and Standards, Washington, D.C.: U.S. EPA, October 1982.
54. *Petroleum Refinery Enforcement Manual*, U.S. EPA Office of Enforcement, by PEDCo Environmental Inc., Arlington, Texas, March 1980. EPA-340/1-80-008.
55. Provided by Carole L. Engelder, PhD, PE, Amoco Corporation, Permitting and Operating Services, Texas City, Texas, May 1995.
56. Ibid.
57. *Petroleum Refining - Technology & Economics*, Gary & Handwerk, 3rd Edition, Marcel Dekker, Inc., New York, N.Y., 1994.
58. Ibid.
59. *Petroleum Refining for the Non-Technical Person*, 2nd ed., William L. Leffler, PennWell Publishing Company, Tulsa, Oklahoma, 1985.
60. Ibid.
61. *Petroleum Refinery Enforcement Manual*, U.S. EPA Office of Enforcement, by PEDCo Environmental Inc., Arlington, Texas, March 1980. EPA-340/1-80-008.

62. Ibid.
63. *Petroleum Refining - Technology & Economics*, Gary & Handwerk, 3rd Edition, Marcel Dekker, Inc., New York, N.Y., 1994.
64. *Petroleum Refinery Enforcement Manual*, U.S. EPA Office of Enforcement, by PEDCo Environmental Inc., Arlington, Texas, March 1980. EPA-340/1-80-008.
65. Ibid.
66. *Petroleum Refining - Technology & Economics*, Gary & Handwerk, 3rd Edition, Marcel Dekker, Inc., New York, N.Y., 1994.
67. Ibid.
68. *Petroleum Refinery Enforcement Manual*, U.S. EPA Office of Enforcement, by PEDCo Environmental Inc., Arlington, Texas, March 1980. EPA-340/1-80-008.
69. *Handbook of Petroleum Refining Processes*, Meyers, R.A., McGraw-Hill Book Company, New York, 1986.
70. *Petroleum Refining for the Non-Technical Person*, 2nd ed., William L. Leffler, PennWell Publishing Company, Tulsa, Oklahoma, 1985.
71. Personal interviews with EPA staff.
72. *Assessment of Atmospheric Emissions from Petroleum Refining*, R.G. Wetherold, Radian Corporation, Austin, Texas and U.S. EPA, Office of Research and Development, Washington, DC, April, 1980. (EPA-600/2-80-075e)
73. Wetherold, R.G., Radian Corporation. *Assessment of Atmospheric Emissions from Petroleum Refining: Volume 5. Appendix F*. U.S. Environmental Protection Agency, Washington, DC, 1980. EPA-600/2-80-075e.
74. *Petroleum Refining - Technology & Economics*, Gary & Handwerk, 3rd Edition, Marcel Dekker, Inc., New York, N.Y., 1994.
75. *Petroleum Refinery Enforcement Manual*, U.S. EPA Office of Enforcement, by PEDCo Environmental Inc., Arlington, Texas, March 1980. EPA-340/1-80-008.
76. *Petroleum Refining - Technology & Economics*, Gary & Handwerk, 3rd Edition, Marcel Dekker, Inc., New York, N.Y., 1994.
77. *Compilation of Air Pollutant Emission Factors, Volume I: Stationary Point and Area Sources, Chapter 9, Petroleum Industry*. U.S. EPA, Office of Air and Radiation, Office of Air Quality Planning and Standards, Research Triangle Park, North Carolina, U.S. Government Printing Office, Washington, D.C., September 1985.

78. *Costs to the Petroleum Industry of Major New and Future Federal Government Environmental Requirements*. American Petroleum Institute, Washington, D.C., October 1993.
79. Amoco - U.S. EPA Pollution Prevention Project, Yorktown, Virginia, Project Summary, January 1992.
80. *The U.S. Petroleum Industry: Past as Prologue, 1970-1992*, Energy Information Administration, September, 1993. (DOE/EIA-0572)
81. Ibid.
82. Ibid.
83. Ibid.
84. Ibid.
85. Ibid.
86. Ibid.
87. *Sustainable Environmental Law*, Environmental Law Institute, West Publishing Co., St. Paul, Minn., 1993.
88. 40 CFR Part 60.
89. *Sustainable Environmental Law*, Environmental Law Institute, West Publishing Co., St. Paul, Minn., 1993.
90. 40 CFR Part 61.
91. 40 CFR Part 262.
92. Telephone interviews with EPA staff.
93. 40 CFR Part 262.
94. *Sustainable Environmental Law*, Environmental Law Institute, West Publishing Co., St. Paul, Minn., 1993.
95. Telephone interviews with EPA staff.
96. 40 CFR Part 268.
97. 40 CFR Parts 403 and 419.
98. Telephone interviews with EPA staff.

99. *Sustainable Environmental Law*, Environmental Law Institute, West Publishing Co., St. Paul, Minn., 1993.
100. Ibid.
101. 40 CFR Parts 313, 302, and 304.
102. *Sustainable Environmental Law*, Environmental Law Institute, West Publishing Co., St. Paul, Minn., 1993.
103. Ibid.
104. Telephone interview with CARB staff.
105. *Issues Affecting the Refining Sector of the Petroleum Industry, Hearings Before the Committee on Energy and Natural Resources, United States Senate, Washington, DC, May 19, 1992, Cheyenne, WY, May 28, 1992*, U.S. GPO, Washington, DC, 1992.
106. *Sustainable Environmental Law*, Environmental Law Institute, West Publishing Co., St. Paul, Minn., 1993.
107. Telephone interview with EPA staff.
108. *The U.S. Petroleum Industry: Past as Prologue, 1970-1992*, Energy Information Administration, September, 1993. (DOE/EIA-0572)
109. Telephone interview with EPA staff.
110. *The Clean Air Act Amendments: Strategies for the 1990s*. Hale and Dorr, Counsellors and Law and TRC Environmental Consultants, Inc.
111. Telephone interview with EPA staff.
112. Amoco - U.S. EPA Pollution Prevention Project, Yorktown, Virginia, Project Summary, January 1992.