

# Lessons Learned



## From Natural Gas STAR Partners

### REPLACING GAS-ASSISTED GLYCOL PUMPS WITH ELECTRIC PUMPS

#### Executive Summary

Approximately 36,000 glycol dehydrators in the natural gas production sector are used to remove water from the gas. Most glycol dehydration systems use triethylene glycol (TEG) as the absorbent fluid and rely on pumps to circulate TEG through the dehydrator. Operators use two types of circulation pumps: gas-assisted glycol pumps, also referred to as “energy-exchange pumps,” and electric pumps.

Gas-assisted pumps are the most common circulation pumps in remote areas that do not have an electrical power supply. They are basically pneumatic gas driven pumps, specially designed to take advantage of the energy of high-pressure natural gas entrained in the rich (wet) TEG leaving the gas contactor. Additional high-pressure wet production gas is necessary for mechanical advantage, and therefore more methane rich gas is carried to the TEG regenerator, where it is vented with water boiled off of the rich TEG. The mechanical design of these pumps places wet, high-pressure TEG opposed to dry, low pressure TEG, separated only by rubber seals. Worn seals result in contamination of the lean (dry) TEG making it less efficient in dehydrating the gas, requiring higher glycol circulation rates. Typical methane emissions are about 1,000 cubic feet (Mcf) for each million cubic feet (MMcf) of gas treated.

Replacing gas-assisted pumps with electric pumps increases system efficiency and significantly reduces emissions. For example, a 10 MMcf per day dehydrator could save up to 3,000 Mcf of gas a year, worth \$21,000.

Method for Reducing Methane Emissions	Volume of Natural Gas Saved (Mcf/yr)	Value of Natural Gas Savings (\$/yr)	Cost of Implementation (\$)	Payback
Replace gas-assisted pumps on glycol dehydrators with electric pumps	360 - 36,000 per dehydration system <sup>1</sup>	\$2,520 - \$252,000 <sup>2</sup>	\$2,700 - \$15,100	< 1 month to several years

<sup>1</sup> Depending on TEG circulation rate and inlet gas temperature and pressure, as reported by Natural Gas STAR partners.

<sup>2</sup> At gas price of \$7.00 per Mcf.

## Technology Background

Most natural gas producers use triethylene glycol (TEG) gas dehydrators to remove water from the natural gas stream to meet pipeline quality standards. TEG is circulated through the dehydration system using pumps powered either by an electric motor or by a gas expansion piston or turbine driver. The latter is called a “gas-assisted” or “energy-exchange” pump. In some operations, a combination gas-assist/electric pump system may be used.

The gas dehydration process includes the following elements:

- ★ Wet natural gas is fed into a glycol contactor, where it bubbles up counter-current through “lean TEG” (triethylene glycol without absorbed water) in the contactor tower trays.
- ★ Lean TEG absorbs water and under pressure, some methane from the natural gas stream-becoming “rich TEG.”
- ★ Dry gas goes to the sales pipeline.
- ★ A reboiler operating at atmospheric pressure regenerates the rich TEG by heating the glycol to drive off water, absorbed methane and other contaminants, which are vented to the atmosphere.
- ★ The regenerated (lean) TEG is pumped back up to contactor pressure and injected at the top of the contactor tower.

Exhibit 1 is a diagram of a typical glycol dehydrator system. The atmospheric vent stack on the glycol reboiler/regenerator is the main source of methane emissions. Reduction of methane emissions is achieved by reducing the amount of wet gas bypassed to supplement the rich TEG that is regenerated in the reboiler. There are three ways to reduce the methane content of the rich TEG stream:

- ★ Reducing the TEG circulation rate.
- ★ Installing a flash tank separator in the dehydration loop.
- ★ Replacing gas-assisted pumps with electric pumps.

Replacing gas-assisted pumps with electric pumps is the subject of this Lessons Learned paper. The other methane emission reduction options are discussed in EPA’s *Lessons Learned: Optimize Glycol Circulation and Install Flash Tank Separators in Glycol Dehydrators*.

### **Gas-Assisted Pumps**

The most common circulation pump used in dehydrator systems is the gas-assisted glycol pump. An example of a popular piston type is shown in Exhibit 2. These mechanical pumps are specially designed to use rich TEG and natural gas at high pressure for power. By design, gas-assisted glycol

## Exhibit 1: Dehydrator Schematic

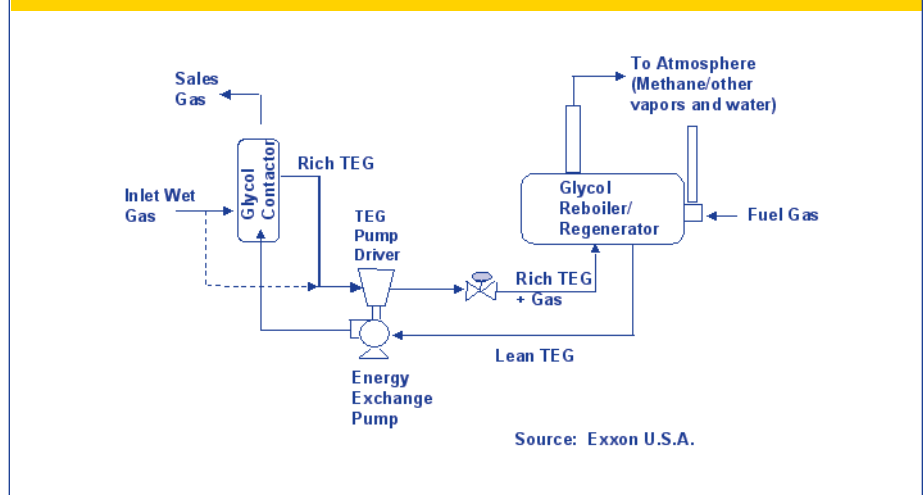

pumps increase emissions from dehydrator systems by passing the pneumatic driver gas entrained with rich TEG to the reboiler. A basic overview of the pump's operation is described below:

- ★ The high-pressure natural gas entrained in rich TEG from the contactor (plus additional wet, high pressure gas) expands from contactor pressure (200 to 800 psig) down to reboiler pressure (zero psig), pushing against the driver side of the main cylinder piston.
- ★ The other side of that piston pushes a cylinder full of low-pressure lean TEG out to the contactor at high-pressure.
- ★ The driving piston is connected to a mirror-image piston, which simultaneously expels low-pressure rich TEG to the regenerator, while sucking in low-pressure lean TEG from the regenerator.
- ★ At the end of the stroke, slide valves switch the position of the pilot piston, redirecting high-pressure rich TEG to the opposite drive cylinder. Check valves on the suction and discharge from the lean TEG cylinders prevent back-flow.
- ★ The pistons are then driven back in the other direction, one expanding gas in the rich TEG while pressuring lean TEG to the contactor, the other expelling the now low-pressure rich TEG to the regenerator while filling the other side with low-pressure lean TEG from the regenerator.
- ★ The driver-side rich TEG mixture with low-pressure natural gas passes to the reboiler where the entrained gas separates and water is boiled out of solution with the TEG.

- ★ The water vapor and separated gas mixture of methane and other hydrocarbon gas contaminants (VOCs and HAPs) are vented to the atmosphere.
- ★ At the end of each stroke, the flow paths are switched, and high-pressure rich TEG pushes the pistons back.

This type pump has an inherent design requirement that extra high-pressure gas be added to supplement the gas absorbed in the rich TEG from the contactor (about two volumes for one) to provide mechanical advantage on the driver side. This means that a gas-assisted pump passes about three times as much gas to the regenerator as an electric motor driven pump would. Furthermore, gas-assisted pumps place high-pressure wet TEG opposite low-pressure dry TEG in four locations with rings on the two pistons and “O-rings” on the central piston connecting rod separating them. As the piston rings becomes worn, grooved, or the O-rings wear, rich TEG leaks past, contaminating the lean TEG. This contamination decreases the dehydrator’s capacity to absorb water and reduces system efficiency. Eventually, the contamination becomes sufficient to prevent the gas from meeting pipeline specifications (commonly 4 to 7 lb of water per MMcf).

As little as 0.5 percent contamination of the lean TEG stream can double the circulation rate required to maintain the same effective water removal. In some cases, operators can over circulate the TEG as the dehydrator loses efficiency, which in turn, can lead to even greater emissions.

## Economic and Environmental Benefits

### Electric Pumps

In contrast to gas-assisted pumps, electric motor driven pumps have less design-inherent emissions and no pathway for contamination of lean TEG by the rich stream. Electric pumps only move the lean TEG stream; the rich TEG flows by pressure drop directly to the regenerator, and contains only dissolved methane and hydrocarbons. Exhibit 2 shows an example of an electric glycol pump assembly.

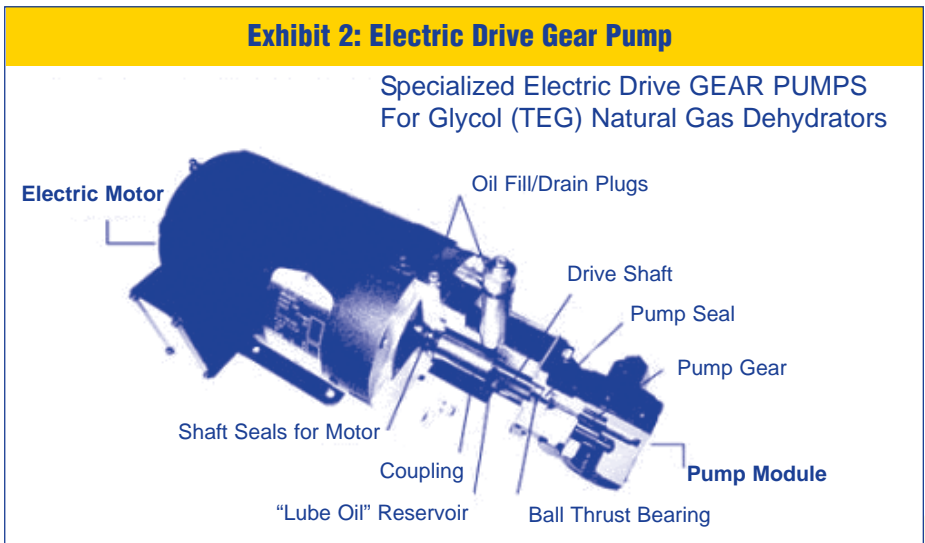

Source: Kimray, Inc.

Using electric pumps as alternatives to gas-assisted pumps can yield significant economic and environmental benefits, including:

- ★ **Financial return on investment through reduced gas losses.** Using gas-assisted glycol pumps reduces methane emissions by a third or more. All of the wet production gas remains in the system to be dehydrated and sold as product. In many cases, the cost of implementation can be recovered in less than 1 year.
- ★ **Increased operational efficiency.** Worn O-rings in gas-assisted glycol pumps can cause contamination of the lean TEG stream in the dehydrator, reducing system efficiency and requiring an increase in glycol circulation rate, compounding the methane emissions. The design of electric pumps eliminates the potential for this contamination to occur and thereby increases the operational efficiency of the system.
- ★ **Reduced maintenance costs. Replacing gas-assisted glycol pumps often results in lower annual maintenance costs.** The floating piston O-rings in gas-assisted pumps must be replaced when they begin to leak, typically every 3 to 6 months. The need for this replacement is eliminated when electric pumps are employed.

## Decision Process

- ★ **Reduced regulatory compliance costs.** The cost of complying with federal regulations of hazardous air pollutants (HAPs) can be reduced through the use of electric pumps. Dehydrator HAP emissions, including volatile organic compounds such as benzene, toluene, ethyl benzene, and xylene (BTEX), are significantly lower in units powered by electric pumps.

A five-step process can be used to evaluate replacement of gas-assisted glycol pumps with electric pumps. Each step requires field data to accurately reflect conditions at the site being evaluated.

**Step 1: Determine whether an electricity source is available.** Electricity to power an electric pump can be purchased from a local grid or generated onsite using lease or casing head gas that might otherwise be flared. If a source of electricity is available or can be obtained cost-effectively, the operator should proceed to Step 2. When no electricity source is available, a gas-assisted glycol pump might be the only option. Combination hydraulic-electric pumps should also be considered for field situations where only single-phase power is available, purchased power costs are high, or there is insufficient electrical service for a large electric motor. A combination pump uses high-pressure, wet glycol to drive a hydraulic rotary gear motor/pump; a small single-phase electric motor is added for mechanical advantage, in place of the bypassed wet gas in the gas-assisted pump. In either case, using a properly sized, well-maintained, efficient pump maintained at the correct circulation rate can minimize gas loss.

**Step 2: Determine the appropriate size of the electric pump.** A variety of electric pumps are available to meet site-specific operational requirements. Electric TEG pumps can be powered by AC or DC, single phase or 3-phase, 60 Hz or 50 Hz. They are available with a choice of variable or constant operating speeds. Pump capacities range from 10 to 10,000 gallons per hour (GPH).

### Five Steps to Evaluate the Use of Electric Pumps

1. Determine whether an electricity source is available.
2. Determine the appropriate size of the electric pump.
3. Estimate the capital, operation, and maintenance costs.
4. Estimate the quantity and value of gas savings.
5. Calculate the net economic benefit of replacement.

The correct pump size for a dehydrator system should be calculated based on the circulation rate and the operating pressure of the system. Exhibit 3 illustrates how to calculate the horsepower needed (in Brake Horsepower or BHP) for an electric pump using typical system information.

### Exhibit 3: Sizing the Pump

**Given:**

Q = Circulation rate (in gallons per minute) = 5 gal/min

P = Pressure (in psig) = 800 psig

E = Efficiency = 0.85

**Calculate:**

BHP =  $(Q \times P / 1,714) \times (1/E)$

=  $(5 \times 800 / 1,714) \times (1/0.85)$

BHP = 2.75

In the example shown in Exhibit 3, an operator would need at least a 2.75 horsepower pump, and would therefore round up to the next available size (i.e., a 3.0 BHP pump).

Operators might wish to obtain a pump one size larger than called for by the formula above. A larger pump provides additional capability to increase the glycol circulation rate, if needed, to accommodate input gas with higher water content, or to meet more stringent output specifications. Variable speed electric pumps are also available. Although larger pumps or variable speed pumps can cost slightly more to operate, a larger size provides an additional measure of safety and flexibility to cover contingencies.

### Nelson Price Indexes

In order to account for inflation in equipment and operating & maintenance costs, Nelson-Farrar Quarterly Cost Indexes (available in the first issue of each quarter in the *Oil and Gas Journal*) are used to update costs in the Lessons Learned documents.

The “Refinery Operation Index” is used to revise operating costs while the “Machinery: Oilfield Itemized Refining Cost Index” is used to update equipment costs.

To use these indexes in the future, simply look up the most current Nelson-Farrar index number, divide that by the February 2006 Nelson-Farrar index number, and, finally, multiply by the appropriate costs in the Lessons Learned.

#### Exhibit 4: Capital Cost of Electric Pumps

Pump Motor Size (BHP)	.25	.50	.75	1.0	1.5	2.0	3.0	5.0	7.5	10
Pump and Motor Cost (\$)	1,420	1,485	1,550	1,630	1,680	1,770	1,845	3,795	3,995	4,205

Source: Kimray, Inc., updated to 2006 equipment costs

**Step 3: Estimate the capital, operation, and maintenance costs.** Costs associated with electric pumps include capital to purchase the equipment, installation, and ongoing operation and maintenance.

#### (a) Capital and installation costs

Electric pumps can cost from \$1,425 to nearly \$12,953, depending on the horsepower of the unit. Exhibit 4 presents a range of sample capital costs for electric pumps of different sizes typically used for glycol dehydrators. Operators should also consider installation costs when evaluating the overall economics of electric pumps. Estimate 10 percent of capital costs for installation. Coordinating replacements with planned maintenance shutdowns can minimize installation costs.

#### (b) Operation and maintenance costs

The primary operational cost of an electric pump is the electricity needed to power the unit. In general, the kilowatt (kW) requirement to run a pump is nearly the same as BHP. For example, a 3.0 BHP pump would require approximately 3.0 kW to operate.

In 2006, the average cost of purchased electricity in the commercial and industrial sectors ranged from \$0.061 to \$0.094 per kilowatt-hour (kWh) nationally; site-generated electricity cost approximately \$0.02 per kWh. If electricity costs are assumed to be approximately \$0.075 per kWh, the estimated cost for purchased power for the 3.0 BHP pump identified above would be \$1,971 per year (3.0 kW x 8,760 hrs/yr x \$0.075/kWh). The cost for site-generated electricity would be about \$525 per year (3.0 kW x 8,760 hrs/yr x \$0.02/kWh).

Typical maintenance costs for gas-assisted glycol pumps range from \$270 to \$530 annually. Maintenance cost is primarily associated with internal O-ring replacements and related labor costs. Normally, these replacements are necessary once every three to six months.

Electric pumps are usually gear-driven. They have no reciprocating pump parts and do not depend on elastomeric parts, slides, pistons, check valves, or internal O-rings, which are all subject to wear, deterioration, and replacement. As a result, maintenance costs for electric pumps are generally less

than maintenance costs for gas-assisted glycol pumps. Annual costs for electric pumps can be expected to be about \$263 per year for labor, consumables (lubrication and seals), and inspection.

**Step 4: Estimate the quantity and value of gas savings.** Because electric pumps emit no methane, emissions savings from an electric pump installation are equal to the emissions from the gas-assisted pump being replaced. The quantity of avoided emissions can then be multiplied by the market price of gas to determine the total value of gas savings. Note: if the glycol

### Exhibit 5: Estimate Methane Emissions from Glycol Dehydrators<sup>1</sup>

#### Step 1: Calculate Emissions Factor

**Given:**

EF = Emission Factor (scf natural gas emitted/MMcf gas processed)

PGU = Pump Gas Usage (scf natural gas emitted/gallon of TEG)<sup>2</sup>

G = Glycol-to-Water Ratio (gallons of TEG/lb water removed)<sup>3</sup>

WR = Water Removed Rate (lb water removed/MMcf gas processed)

OC = Over Circulation Ratio

**Calculate:**

EF = PGU x G x WR x OC

#### Step 2: Calculate Total Emissions

**Given:**

TE = Total Emissions

AF = Activity Factor (MMcf gas processed annually)

**Calculate:**

TE = EF x AF

<sup>1</sup> Calculation methods and standard values are presented in EPA's *Lessons Learned: Optimize Glycol Circulation and Install Flash Tank Separators in Glycol Dehydrators*.

<sup>2</sup> Industry Rule-of-Thumb: 3 cubic-ft/gal for gas-assisted pump, 1 cubic-ft/gal for electric pump; the difference being 2 cubic-ft/gal.

<sup>3</sup> Industry accepted Rule-of-Thumb: 3 gal TEG/lb water.

dehydration unit has a flash tank separator, and a beneficial use for all gas recovered, then the gas savings might not, by itself, provide enough justification for installing an electric pump.

#### (a) Estimate methane emissions from the gas-assisted pump

Estimating emissions is a two-step process, which consists of calculating an emissions factor for the unit's operational characteristics (pressure, temperature, moisture specs) and then multiplying the unit emissions factor by an activity factor (amount of gas processed annually). Exhibit 5 presents formulas for estimating the potential methane emissions from a gas-assisted

pump and, consequently, the potential methane savings from replacing the gas-assisted pump with an electric pump.

Field operators often know or can calculate the pump gas usage and the glycol-to-water ratio. To determine the quantity of water that needs to be removed (WR), refer to Appendix A, which presents a set of empirically derived curves. Using the gas inlet temperature and system pressure, the saturated water content can be determined by reading the corresponding value where the psig curve intersects the temperature. Subtract 4 lb/MMcf to 7 lb/MMcf of water from the water content value to determine WR. The 4 lb/MMcf to 7 lb/MMcf water content limitation is based on typical pipeline specifications for water content in the gas stream.

To estimate the over circulation ratio, use a 1:1 ratio ( $OC = 1$ ) if there is no over circulation and a 2.1:1 ratio ( $OC = 2.1$ ) if over circulation is an issue. These ratios are based on the average of measured ratios from 10 field units reported by the Gas Research Institute.

Two examples of determining water removal (WR), emission factor (EF), and total emissions (TE) are provided on the pages that follow. Each example shows a range of savings based upon the two different inlet assumptions. Example 1 presents a high-pressure gas stream, and Example 2 presents a low-pressure stream.

#### **Example 1: High-Pressure Gas Stream:**

This example dehydration system has an inlet pressure of 800 psig, a temperature of 94° F, and a glycol-to-water ratio of 3.0 gallons of TEG per lb water recovered. Using Appendix A, the saturated water content for the gas stream is estimated by reading the corresponding value where the 800-psig curve intersects the 95° F line. In this example, the water content is about 60 lb per MMcf. Subtracting the pipeline requirement of 7 lb/MMcf, results in 53 lb of water, which must be removed from the gas stream and absorbed by the TEG. The pump gas usage is 2 scf of natural gas per gallon of TEG.

Applying these data to the emissions factor formula results in a range of 318 to 668 scf gas emitted for every MMcf gas processed. Assuming the dehydrator processes 10 MMcf of wet gas daily, the additional volume of the gas recovered would be 1,160 to 2,440 Mcf per year. Exhibit 6 summarizes this example.

### Exhibit 6. Example 1: Estimated Methane Emissions from a Glycol Dehydrator with High Pressure (800 psig) Inlet Gas

**Where:**

EF = Emission Factor (scf natural gas emitted/MMcf gas processed)

PGU = Pump Gas Usage (scf natural gas emitted/gallon of TEG)

G = Glycol-to-Water Ratio (gallons of TEG/lb of water removed)

WR = Water Removed Rate (lb of water removed/MMcf gas processed)

OC = Over circulation Ratio

TE = Total Emissions

AF = Activity Factor (MMcfd gas processed)

**Given:**

PGU = 2 scf natural gas emitted/gallon TEG

G = 3.0 gallons of TEG/lb of water removed

WR = 53 lb of water removed/MMcf gas processed

OC = 1:1 to 2.1:1

AF = 10 MMcfd gas processed

**Calculate:**

$$\begin{aligned} \text{EF} &= \text{PGU} \times \text{G} \times \text{WR} \times \text{OC} \\ &= 2 \times 3.0 \times 53 \times (\text{Range: } 1 \text{ to } 2.1) \\ &= 318 \text{ to } 668 \text{ scf/MMcf} \end{aligned}$$

$$\begin{aligned} \text{TE} &= \text{EF} \times \text{AF} \\ &= (318 \text{ to } 668) \times 10 \\ &= (3,180 \text{ to } 6,680) \text{ scfd} \times 365 \text{ days/year} \div 1,000 \text{ scf/Mcf} \\ &= 1,160 \text{ to } 2,440 \text{ Mcf/year} \end{aligned}$$

#### Example 2: Low-Pressure Gas Stream:

The system uses an inlet pressure of 300 psig and a temperature of 94° F, and a glycol-to-water ratio of 3.0 gallons of TEG per lb water recovered. Again referring to the Smith Industries' curves (Appendix A), the water content is about 130 lb per MMcf. Therefore, 123 lb of water must be removed from the natural gas stream and absorbed by the TEG to meet the pipeline standards. In this example, the pump size is 3.0 BHP, and the pump gas usage is 2.8 scf of natural gas emitted per gallon of TEG. Using the formula, an Emissions Factor (EF) of 1.03 to 2.17 Mcf/MMcf is estimated. Assuming the dehydrator processes 10 MMcf of wet gas daily, the additional volume of the gas recovered would be 3,760 to 7,921 Mcf per year. Exhibit 7 summarizes this example.

### Exhibit 7: Example 2: Estimated Methane Emissions from a Glycol Dehydrator with Low Pressure (300 psig) Inlet Gas

#### Where:

EF = Emission Factor (scf natural gas emitted/MMcf gas processed)

PGU = Pump Gas Usage (scf) natural gas emitted/gallon of TEG)

G = Glycol-to-water Ratio (gallons of TEG/lb of water removed)

WR = Water Removed Rate (lb of water removed/MMcf gas processed)

OC = Over circulation Ratio

TE = Total Emissions

AF = Activity Factor (MMcfd gas processed)

#### Given:

PGU = 2.8 scf natural gas emitted/gallon TEG

G = 3.0 gallons of TEG/lb of water removed

WR = 123 lb of water removed/MMcf gas processed

OC = 1:1 to 2.1:1

AF = 10 MMcfd gas processed

#### Calculate:

EF = PGU x G x WR x OC = 2.8 x 3.0 x 123 x (Range: 1 to 2.1) = 1,030 to 2,170 scf/MMcf

TE = EF x AF = (1030 to 2170) x 10 = 10,300 to 21,700 scfd x 365 days/year ÷ 1000 scf/Mcf = 3,760 to 7,921 Mcf/year

#### (b) Calculate the value of the methane savings

To determine the total value of the methane savings, simply multiply the total emissions reduction by the price of gas. Assuming a value of \$7.00 per Mcf, both the high- and low-pressure examples presented above yield significant annual savings. Increased gas sales from the high-pressure system will range from \$8,120 to \$17,080 per year, while the low-pressure system will yield savings from \$26,320 to \$55,447 per year.

**Step 5: Calculate the net economic benefit of replacement.** To estimate the net economic benefit of replacing a gas-assisted glycol pump with an electric pump, compare the value of the gas saved to the initial cost of the electric pump, plus the electricity and the operation and maintenance costs.

As a general rule, if the cost of electricity exceeds the value of recovered methane and avoided operation and maintenance costs, replacing the gas-assisted glycol pump cannot be justified on a cost-only basis. Even in such cases, however, other factors, such as lower cross contamination rates and environmental benefits (e.g., reduced VOC and HAP emissions) might still make the electric pumps an attractive option at certain sites.

### Methane Content of Natural Gas

Non-associated natural gas found in the production sector contains approximately 78.8% methane. Methane emission reductions can be approximated by applying the methane content of produced natural gas to the natural gas savings calculated in this document.

The following exhibit uses the low-pressure example from Step 4 to demonstrate the possible savings available to operators who purchase electricity.

<b>Exhibit 8: Economic Benefit of Replacing Gas-Assisted Glycol Pump with an Electric Pump—Low Pressure Inlet Gas Example</b>						
Gas Volume Saved per Year (Mcf)	Value of Gas Saved per Year <sup>1</sup>	3.0 BHP Electric-Pump Cost <sup>2</sup>	Electricity Cost per Year	Electric Pump Maintenance (\$/Year)	Gas-Assisted Pump Maintenance (\$/Year)	Payback in months
3,760 - 7,921	\$26,320 - \$55,447	\$2,400	\$1,971	\$263	\$530	1- 2
<sup>1</sup> Gas valued at \$7.00 per Mcf. <sup>2</sup> Including capital cost and installation cost, which is assumed to be 30 percent of the capital cost for this example.						

It is important to note that larger pump sizes require a larger up-front investment, and higher electricity costs might result in longer payback periods. It is therefore important to correctly calculate the pump size required and to circulate the TEG at the optimal rate.

In addition, as part of looking at the overall replacement economics, operators should consider the timing of any replacements. Older gas-assisted glycol pumps, at the end of their useful lives, are typically good candidates for replacement with an electric pump. Gas-assisted pumps that might not be at the end of their useful life, but that have started to need more frequent maintenance as a result of increased contamination, might also be good candidates for replacement.

**Partner Reported Savings**

One Natural Gas STAR Partner reported recovering an average of 15,000 Mcf/year of methane by replacing four gas-assisted glycol pumps with electric pumps. At \$7.00 per Mcf, this amounted to an average of \$105,000 in additional product sales.

When assessing options for glycol pumps and dehydrators, natural gas price may influence the decision making process. Exhibit 9 shows an economic analysis of installing an electric pump on a low pressure glycol dehydrator at different natural gas prices.

<b>Exhibit 9: Gas Price Impact on Economic Analysis</b>					
	<b>\$3/Mcf</b>	<b>\$5/Mcf</b>	<b>\$7/Mcf</b>	<b>\$8/Mcf</b>	<b>\$10/Mcf</b>
<b>Value of Gas Saved</b>	\$11,280	\$18,800	\$26,320	\$30,080	\$37,600
<b>Payback Period (Months)</b>	3	2	2	2	1
<b>Internal Rate of Return (IRR)</b>	415%	729%	1042%	1199%	1512%
<b>Net Present Value (i=10%)</b>	\$35,384	\$63,891	\$92,397	\$106,651	\$135,157

## Lessons Learned

Installing electric pumps to replace gas-assisted glycol pumps can offer significant operational, environmental, and economic advantages. Natural Gas STAR partners offer the following lessons learned:

- ★ Gas-assisted glycol pumps can often be cost-effectively replaced with electric pumps if there is a readily available source of electricity.
- ★ Electric pumps are available with varying capabilities and efficiencies. Operators are encouraged to work with various pump manufacturers to find the most appropriate type.
- ★ In sizing an electric pump, operators might wish to obtain a pump that is one size larger than normal. This will allow for additional circulation capacity that can prove useful if the water content increases as the field matures or “waters out.”
- ★ Glycol pumps, whether gas-assisted or electric, represent only one element of a dehydration system. Operators should consider the dehydration process as a whole, including glycol composition, circulation rates, contactor temperature and pressure, inlet gas composition, dew point requirements, and reboiler temperatures.
- ★ Partners considering replacing gas-assisted pumps with electric pumps should review the other opportunities for reducing methane emissions from dehydration systems. See EPA’s *Lessons Learned: Optimize Glycol Circulation And Install Flash Tank Separators In Glycol Dehydrators*.
- ★ Glycol dehydrators with flash tank separators might not be good candidates for replacing the gas-assisted pump, because most of the excess gas is recovered and put to beneficial use or recycled.

- ★ Include reduction in methane emissions from replacing gas-assisted glycol pumps with electric pumps in annual reports submitted as part of the Natural Gas STAR Program.

---

## References

- American Petroleum Institute. Specifications for Glycol-Type Dehydration Units (Spec 12 GDU). July 1993.
- American Petroleum Institute. Glycol Dehydration. PROFIT Training Series, 1979.
- Ballard, Don. How to Improve Glycol Dehydration. Coastal Chemical Company.
- Collie, J., M. Hlavinka, and A. Ashworth. An Analysis of BTEX Emissions from Amine Sweetening and Glycol Dehydration Facilities. 1998 Laurance Reid Gas Conditioning Conference Proceedings, Norman, OK.
- Garrett, Richard. Making Choices—A Look at Traditional and Alternative Glycol Pump Technology.
- Gas Research Institute. Technical Reference Manual for GRI-GLYCalc TM Version 3.0 (GRI-96/0091).
- Gas Research Institute and U.S. Environmental Protection Agency. Methane Emissions from Gas-Assisted Glycol Pumps. January 1996.
- The Hanover Compressor Company. Personal Contact.
- Kimray, Inc. Personal Contact.
- Radian International LLC, “Methane Emissions from the Natural Gas Industry. Volume 15: Gas-Assisted Glycol Pumps” Draft Final report, Gas Research Institute and U.S. Environmental Protection Agency, April 1996
- Rotor-Tech, Inc. Personal Contact.
- Tannehill, C.C., L. Echterhoff, and D. Leppin. “Production Variables Dictate Glycol Dehydration Costs.” American Oil and Gas Reporter, March 1994.
- Tingley, Kevin. U.S. EPA Natural Gas STAR Program. Personal Contact.
- U.S. Environmental Protection Agency. National Emission Standards for Hazardous Air Pollutants for Source Categories: Oil and Natural Gas Production and Natural Gas Transmission and Storage-Background Information for Pro-posed Standards (EPA-453/R-94-079a, April 1997).
- U.S. Environmental Protection Agency. Lessons Learned: Reducing the Glycol Circulation Rates in Dehydrators (EPA430-B-97-014, May 1997).
- U.S. Environmental Protection Agency. Lessons Learned: Installation of Flash Tank Separators (EPA430-B-97-008, October 1997).
- U.S. Environmental Protection Agency. “Methods for Estimating Methane Emissions from National Gas and Oil Systems”. Emissions Inventory Improvement Program, Vol. III, Chapter 3, October 1999

# APPENDIX A

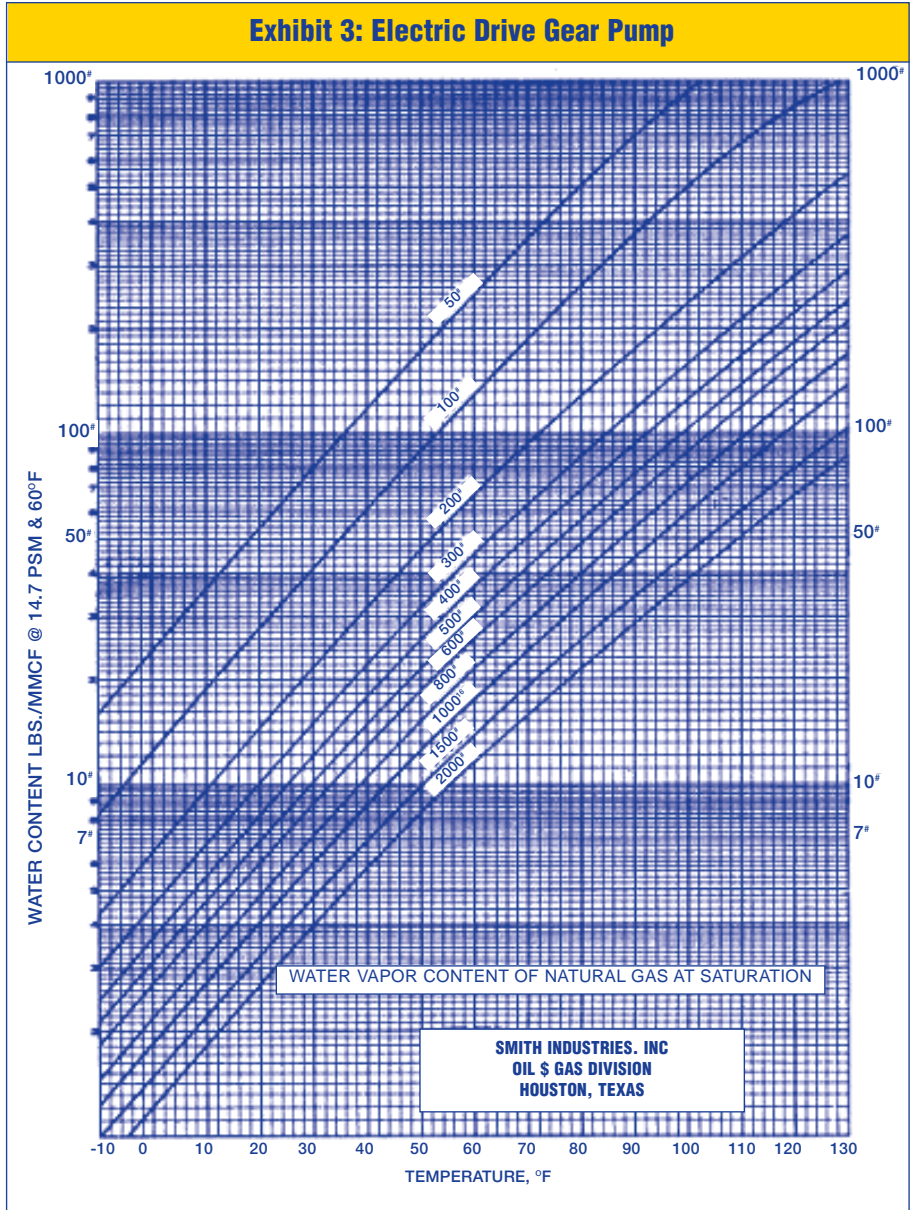

Source: Kimray, Inc.



United States  
Environmental Protection Agency  
Air and Radiation (6202J)  
1200 Pennsylvania Ave., NW  
Washington, DC 20460

October 2006