

Lessons Learned



From Natural Gas STAR Partners

REDUCING METHANE EMISSIONS FROM COMPRESSOR ROD PACKING SYSTEMS

Executive Summary

More than 51,000 reciprocating compressors are operating in the U.S. natural gas industry, each with an average of four cylinders, representing over 200,000 piston rod packing systems in service. These systems contribute over 72.4 Bcf per year of methane emissions to the atmosphere, one of the largest sources of emissions at natural gas compressor stations.

All packing systems leak under normal conditions, the amount of which depends on cylinder pressure, fitting and alignment of the packing parts, and amount of wear on the rings and rod shaft. A new packing system, properly aligned and fitted, may lose approximately 11 to 12 standard cubic feet per hour (scfh). As the system ages, however, leak rates will increase from wear on the packing rings and piston rod. One Natural Gas STAR partner reported measuring emissions of 900 scfh on one compressor rod.

By using company-specific financial objectives and monitoring data, partners can determine emission levels at which it is cost-effective to replace rings and rods. Benefits of calculating and utilizing this “economic replacement threshold” include methane emission reductions and cost savings. Using this approach, one Natural Gas STAR partner achieves savings of over \$233,000 annually at 2006 gas prices. An economic replacement threshold approach also results in operational benefits, including a longer life for existing equipment, improvements in operating efficiencies, and long-term savings.

Method for Reducing Methane Emissions	Volume of Natural Gas Savings (Mcf)	Value of Natural Gas Savings (\$/yr)	Cost of Implementation (\$)	Payback (months)
Economic replacement of rings and rods in compressor rod packing	865 ¹	\$6,055 ²	\$540 ³	2

¹ Pipeline Research Committee International (1999).

² Gas valued at \$7.00 per Mcf.

³ \$1,620 cost of ring replacement every three years rather than four years (industry average).

Technology Background

Reciprocating compressors in the natural gas industry leak natural gas during normal operation. Areas of high leak frequency include flanges, valves, and fittings located on compressors. The highest volume of gas loss, however, is associated with piston rod packing systems.

Packing systems are used to maintain a tight seal around the piston rod, preventing the gas compressed to high pressure in the compressor cylinder from leaking, while allowing the rod to move freely. Exhibit 1 shows a typical compressor rod packing system.

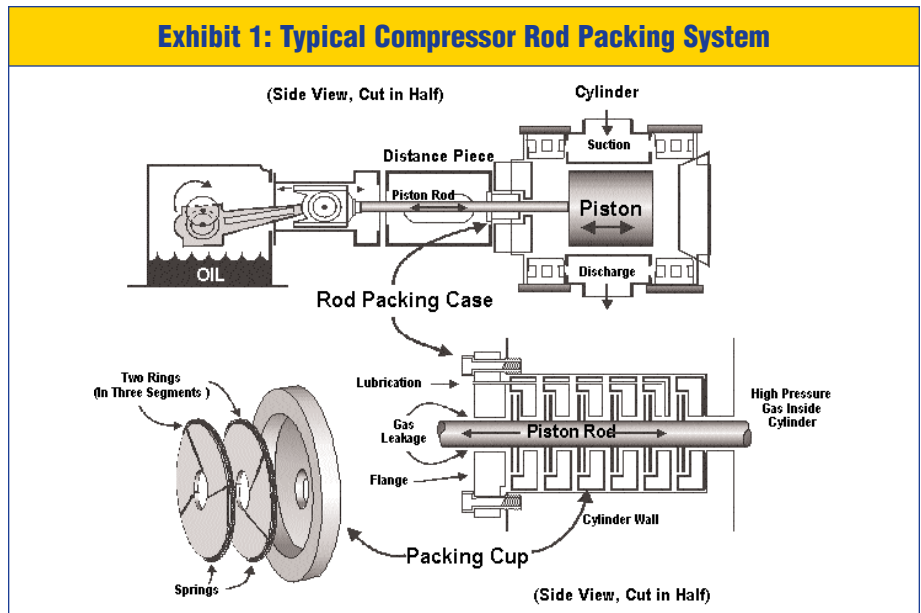

Compressor rod packing consists of a series of flexible rings that fit around the shaft to create a seal against leakage. The packing rings are lubricated with circulating oil to reduce wear, help seal the unit, and draw off heat. Other cooling methods include air cooling, water jacketing, and circulating coolants inside the packing box. Packing rings are held in place by a set of packing cups, normally one for each pair of rings, and kept tight against the shaft by a surrounding spring. The number of cups and rings will vary depending on the compression chamber pressures. A “nose gasket” on the end of the packing case prevents leaks around the packing cups.

Under the best conditions, new packing systems properly installed on a smooth, well-aligned shaft can be expected to leak a minimum of 11.5 scfh. Higher leak rates are a consequence of fit, alignment of the packing parts, and wear. Leakage typically occurs from four areas:

- ★ Around the packing case through the nose gasket.
- ★ Between the packing cups, which are typically mounted metal-to-metal against each other.
- ★ Around the rings from slight movement in the cup groove as the rod moves back and forth.
- ★ Between the rings and shaft.

Leaking gases are vented to the atmosphere through packing vents on the flange. Leakage can be reduced through proper monitoring and a cost-effective schedule for replacing packing rings and piston rods. New ring materials and new designs for packing cases are emerging that should reduce emissions in the future.

Economic and Environmental Benefits

Monitoring and replacing compressor rod packing systems on a regular basis can greatly reduce methane emissions to the atmosphere and save money. For instance, conventional bronze-metallic packing rings wear out and need to be replaced every three to five years. However, as packing deteriorates, leak rates can increase to the level at which replacing packing rings more frequently can be economically justified. In addition, more frequent ring replacement might actually extend the life of the compressor rod. Partners who institute a program of monitoring and cost-effective replacement are able to achieve several benefits:

- ★ Reduced methane emissions.
- ★ Gas savings from lower leakage rates.
- ★ Extended service life of compressor rods.

Decision Process

Companies can determine a cost-effective replacement schedule by following five simple steps.

Step 1: Monitor and record baseline packing leakage and piston rod wear. Establishing baseline leakage rates and monitoring piston rod wear allows Natural Gas STAR partners to track increases in leakage and evaluate the economics of replacing packing rings and piston rods.

The vent port on the packing case flange provides a means for gas leakage to escape to the atmosphere. However, gas can also flow along the rod and/or from the gasket at the end of the packing case, thus bypassing the packing cup vent and entering the distance piece. Consequently, where possible, measurements should encompass emissions from both the packing cup vent and distance piece. Some systems vent the packing cup into the distance piece, while others have separate vents.

Gas leakage can be measured with either a hand held or an installed measuring device.

Before measurements are initiated, a check of the packing vent system should be undertaken. Failure to account for emissions escaping into the distance piece may result in an underestimation of packing related emissions by up to 40 percent, which could impact the economics of the decision process.

It is important to take measurements immediately after installing new seals (or new rods and seals). This measurement becomes the baseline for the new packing and can serve as a suitable default baseline for other cylinders and compressors of similar type, size, pressure, and age of rods. After installation of rings, partners should routinely monitor and record leakage rates and related operating conditions (pressure, lubrication, temperatures) over the entire life of the packing rings, usually on a monthly or quarterly basis.

Rods can be monitored periodically during ring replacements by documenting shaft dimensions and surface roughness where the rod contacts the packing rings. Piston rods wear more slowly than packing rings, having a life of about 10 years. Rods wear “out-of-round” or taper when poorly aligned, which affects the fit of packing rings against the shaft (and therefore the tightness of the seal) and the rate of ring wear. An out-of-round shaft not only seals poorly, allowing more leakage, but also causes uneven wear on the seals, thereby shortening the life of the piston rod and the packing seal. The leakage attributable to rod wear is determined by the change in the baseline leakage rate after each successive ring replacement (assuming same operating conditions and ring type). This increase in baseline leakage can be used to establish an economic threshold for replacing the piston rod (see Step 4).

Step 2: Compare current leak rate to initial leak rate to determine leak reduction expected. Using the monitoring data obtained in Step 1, the baseline emission measurement should be compared to the current leak rate to determine whether the current leak signals a need for packing or rod replacement. Exhibit 2 demonstrates how a comparison can be made.

Five Steps to Economic Packing and Piston Rod Replacement:

1. Monitor and record baseline packing leakage and piston rod wear;
2. Compare current leak rate to initial leak rate to determine leak reduction expected;
3. Assess costs of replacements;
4. Determine economic replacement threshold; and
5. Replace packing and rods when cost-effective.

Exhibit 2: Comparing Current versus Initial Leak Rates

Given:

IL = Initial leak rate at the last packing ring rod replacement

CL = Current leak rate

LRE = Leak reduction expected

Calculate:

$LRE = CL - IL$

For example, if the leak rate of a packing ring is currently measured at 100 standard cubic feet per hour (scfh), and the same component was measured at 11.5 scfh after the last replacement, then the leak reduction that can be expected is:

$LRE = 100 \text{ scfh} - 11.5 \text{ scfh}$

$LRE = 88.5 \text{ scfh}$

For accurate analysis, partners should calculate the “leak reduction expected” (LRE), which is the savings that will occur from installing new equipment separately for packing seals and piston rods. When determining the LRE for the installation of new rings only, assume all of the leakage increase since the last ring replacement is attributable to ring wear. When determining the LRE for replacing the piston rod and rings (note that new rings are always installed with a new rod), use the initial leakage measured immediately after the last rod replacement on this compressor. Where historical data may not be available on individual compressors, data from other similar compressors with similar operating conditions can be used to establish baseline (initial leak) values.

Methane Content of Natural Gas

Pipeline quality natural gas found in the transmission sector contains approximately 93% methane. Methane emission reductions can be approximated by applying the methane content of pipeline quality gas to the natural gas savings calculated in this document.

Step 3: Assess costs of replacements. Costs of replacing packing rings and piston rods vary between compressors. For packing ring replacements, variables include the number of compressor cylinders and the type of replacement ring. A Natural Gas STAR partner reported that costs for a typical Teflon or moly-based, 8 to 10 cup ring set for a three-inch rod will range from \$135 to \$170 per cup, or about \$1,350 to \$1,700 total. Another source stated that a set of rings may vary between \$675 and \$1,080, or \$2,025 to \$3,375 if the cups and cases are included. Factors affecting equipment costs for rod replacements include rod dimension and type of rod. Estimates of the costs of rods can range from \$2,430 to \$4,725. Special coatings, such as ceramic, tungsten carbide, or chromium, can increase costs by \$1,350 or more—the cost of some rods may be as high as \$12,150 to \$13,500.

Nelson Price Indexes

In order to account for inflation in equipment and operating & maintenance costs, Nelson-Farrar Quarterly Cost Indexes (available in the first issue of each quarter in the *Oil and Gas Journal*) are used to update costs in the Lessons Learned documents.

The “Refinery Operation Index” is used to revise operating costs while the “Machinery: Oilfield Itemized Refining Cost Index” is used to update equipment costs.

To use these indexes in the future, simply look up the most current Nelson-Farrar index number, divide that by the February 2006 Nelson-Farrar index number, and, finally, multiply by the appropriate costs in the Lessons Learned.

Installation costs vary as well, depending on site location and difficulties encountered during replacement. Both partners and manufacturers estimate that installation costs are roughly equal to equipment costs. One partner spent an average of \$1,420 per packing ring set for purchase and installation. Partners have found that monitoring and leak measurement costs are insignificant on a per-packing basis relative to the labor costs to install rings or rods.

Step 4: Determine economic replacement threshold. With the information obtained from Steps 1 through 3, partners can develop an “economic replacement threshold” that defines the specific point at which it is cost-effective to replace rings and rods. Partners have identified several methods for calculating this threshold, relying on company investment evaluation criteria and site-specific characteristics.

A simple approach is to use discounted cash flow principles to calculate an economic replacement threshold. Partners can calculate their economic replacement threshold for both packing seals and rods by using the following equation:

$$\text{Economic Replacement Threshold (scfh)} = \frac{CR * DF * 1,000}{(H * GP)}$$

Where:

CR = Cost of replacement (\$)

DF = Discount factor (%)

H = Hours of compressor operation per year

GP = Gas price (\$/Mcf)

The discount factor is the term used for capital recovery for equal annual revenues and is calculated from the following formula:

$$DF = \frac{i(1+i)^n}{(1+i)^n - 1}$$

Where i equals the discount rate or company hurdle rate expressed as a decimal and n equals the payback period selected. Using this formula, a 10 percent discount rate (i = 0.10) and a one-year payback (n = 1) yield a discount factor of 1.10; for a two-year payback (n = 2), the discount factor is 0.576, etc.

Exhibit 3 presents an example for discounted payback. This table was constructed to show the LRE necessary to pay back the investment in a new ring packing set in one year, two years, and so on. Exhibit 3 shows that the \$1,620 cost for packing ring replacement can be paid back in one year with a leak reduction of 55 scfh, in two years with a leak reduction of 29 scfh; etc. (with future leak savings discounted at 10 percent). Thus, if a partner's internal investment criterion is a two-year payback, the partner should establish an economic replacement threshold for ring replacement at 29 scfh. In other words, when the LRE of a ring replacement reaches 29 scfh, the partner should replace ring packing.

Exhibit 3: Economic Replacement Threshold for Packing Rings	
Leak Reduction Expected (scfh)	Payback Period¹ (months)
55	7
29	12
20	18
16	22
13	27

¹Assumes packing ring replacement costs of \$1,620, \$7.00/Mcf gas and 8,000 operating hours/year.

Similar to rings, economic replacement threshold can be determined for rod replacement by establishing the leak reduction needed in order to justify the investment in a new rod assembly. Follow the same steps above, but substitute rod capital costs for cost of replacement (CR) to determine the economic replacement threshold.

After determining the economic replacement threshold, partners should determine the amount of methane emissions attributable to the replacement. Current leakage (CL) measurements do not distinguish between contribution from worn rings and rod wear. However, over time, the initial leakage (IL) measurements will show a gradual increase in the baseline leak rate,

indicating rod wear. Partners should measure and track the change in IL to determine the amount of emissions attributable to the aging rod. Partners need to establish a baseline by which to compare piston rod-related leakage. This can be accomplished by taking measurements when the rod is first installed or by comparing measurements from similar facilities that have new rods and packing. Once this baseline is established, partners can conduct a discounted cash flow to determine the amount of rod-related leakage that signals the need for replacement.

Exhibit 4 uses the same approach as Exhibit 3 to provide the LRE economic replacement thresholds for replacing rings and rods. This example is based on a cost of \$11,701 to replace both the rod and packing rings. The table shows that companies desiring a payback of one year require a LRE of 376 scfh, while a company satisfied with a three-year payback should replace rods and seals when the LRE is 137 scfh (with future savings discounted at 10 percent).

Exhibit 4: Economic Replacement Threshold for Rods & Rings	
Leak Reduction Expected (scfh)	Payback Period¹ (months)
376	7
197	13
137	18
108	22
90	27

¹Assumes packing ring replacement costs of \$1,620, rod replacement costs of \$9,451, \$7.00/Mcf gas and 8,000 operating hours/year.

One note of caution: a poorly aligned rod or poorly fitted rings can result in a high current leakage measurement, and hence a high LRE, that might not indicate the need to replace the rod, but rather a need to refit rings or realign the rod. Monitoring rod dimensions (i.e., tapering, out-of-round, scratches, and surface roughness) is necessary in determining that the increase in IL over the baseline is in fact attributable to general rod wear.

Step 5: Replace packing and rods when cost-effective. Monitoring emissions and replacing worn rods and packing rings at the economic replacement threshold will result in an immediate reduction in emissions and compressor fuel costs. Partners should compare compressor station data to the replacement thresholds. Partners should replace packing rings and rods when actual LREs are equal to or exceed the economic replacement thresholds. Partners are also encouraged to select economic replacement thresholds that maximize the methane reduction.

One Partner's Experience

Consumers Energy replaced worn compressor rod packing rings on 15 compressor units with total estimated savings from reduced gas leakage of \$49,000 (based on leakage reductions of 7,000 Mcf per year, and assuming a gas price of \$7 per Mcf). The costs of replacing all the packing rings, including materials and labor, was \$23,000, resulting in a payback period of six months at 2006 costs.

Additional Options

Partners in the Natural Gas STAR Program have not reached a consensus on standard emission reductions that can be achieved by changing compressor rod packing. Many variables are cited as affecting potential savings, including cylinder pressure, fit and alignment of packing parts, and amount of wear on the rings and rod shaft, as well as company-internal decision criteria. However, partners agree that identifying a replacement threshold for replacing packing rings and piston rods is a practical method to reduce methane emissions from reciprocating compressors.

New materials can improve the life and performance of certain equipment and provide partners with additional savings through reducing leakage and repair and replacement costs.

- ★ **Options for rings.** Carbon-impregnated Teflon is gradually replacing bronze metallic rings. One vendor claims that the price is about the same, with Teflon expected to last about one year longer than the conventional bronze rings. However, other factors—including proper installation, cooling, and lubrication—might play a greater role in the service life of a ring.
- ★ **Upgraded piston rods.** New or existing compressor rods coated with tungsten carbide have proven to increase service life for rods by reducing wear, as well as making them effective for “static-seal” installations (see Lessons Learned study, “*Reducing Emissions When Taking Compressors Off-Line*”). Coating each piston rod with tungsten carbide would cost an additional \$1,350 to \$2,700. Chrome coating is also used to reduce wear.
- ★ **Three-ring rod packing.** A three-ring rod packing system shown in Exhibit 5 is becoming more widespread. The rings are typically installed in one of the last two cups. The primary benefit of this arrangement is that this design can usually be installed without any replacement or modification of the packing case cup.

Exhibit 5: Three-Ring Fugitive Emission Rod Packing Assembly

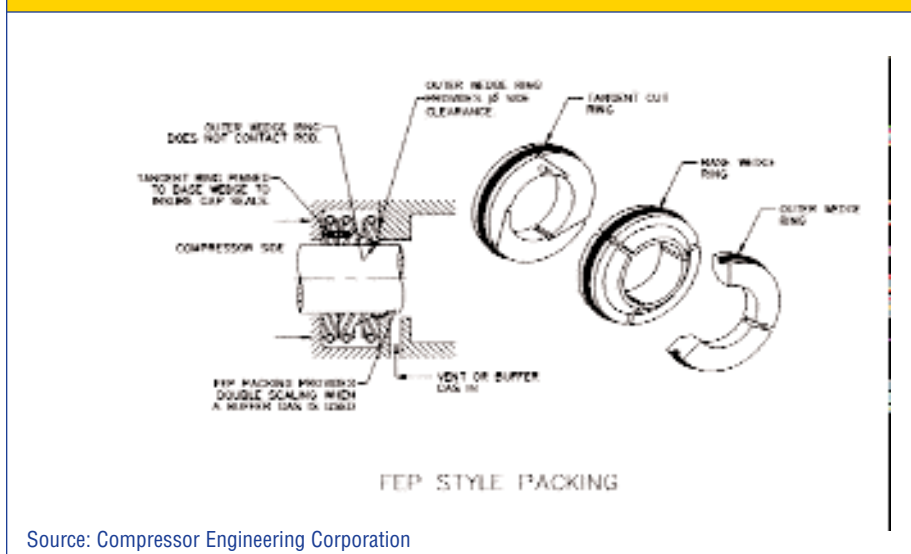

Lessons Learned

Partners have found that providing compressor station personnel with simple guidelines for economic replacement of reciprocating compressor piston rods and rod packing will greatly reduce methane emissions. This natural gas savings pays back the costs for more frequent replacements. The principal lessons learned are:

- ★ Develop a system for regularly measuring and monitoring leakage from piston rod packing cases. Regularly monitor lubrication and cooling to help reduce wear on packing rings. Poor heat conductivity at very high operating temperatures can be a significant factor in ring deterioration.
- ★ Establish baseline initial leakage (IL) rates for new rods and new packing rings, categorized by operating conditions and compressor types and sizes.
- ★ Share baseline initial leakage rate data with other stations to provide substitute data where specific data may not be available for all stations.
- ★ Establish a company-specific emission threshold for each compressor to serve as a useful tool for knowing when to replace packing rings and piston rods economically.
- ★ Upgrade piston rods where economically justified. The upgrades will result in fewer emissions over the life of the rod.
- ★ New packing ring materials, types, and entirely new packing systems are available and becoming more common where product values or environmental factors offset the higher costs.

References

- ★ For additional information, consult the Lessons Learned study entitled *Reducing Emissions When Taking Compressors Off-Line*.
- ★ When changing out packing rings and rods, record methane emissions reductions in Natural Gas STAR Program annual reports.

Alastair J. Campbell, Bently Nevada Corporation, Houston, Texas. *Optical Alignment of Reciprocating Compressors*.

Borders, Robert, C. Lee Cook, Louisville, Kentucky, personal contact.

France Compressor Products. *Mechanical Packing—Design and Theory of Operation, Bulletin 691*.

Miniot, Joe, Compressor Engineering Corporation, Houston, Texas, personal contact.

Parr, Robert, TF Hudgins, Houston, Texas, personal contact.

Pipeline & Gas Journal, “Compressor Shutdown Leakage,” December 1985.

Pipeline Research Committee International, *Cost-Effective Leak Mitigation at Natural Gas Transmission Compressor Stations*, PR-246-9526, August 1999.

Schroeder, David M., France Compressor Products, Newtown, Pennsylvania, personal contact.

Tingley, Kevin, U.S. EPA Natural Gas STAR Program, personal contact.



1EPA

United States
Environmental Protection Agency
Air and Radiation (6202J)
1200 Pennsylvania Ave., NW
Washington, DC 20460

EPAxxx
xxx 2006