

Lessons Learned

From Natural Gas STAR Partners



REPLACING WET SEALS WITH DRY SEALS IN CENTRIFUGAL COMPRESSORS

Executive Summary

Centrifugal compressors are widely used in production and transmission of natural gas. Seals on the rotating shafts prevent the high-pressure natural gas from escaping the compressor casing. Traditionally, these seals used high-pressure oil as a barrier against escaping gas. Natural Gas STAR partners have found that replacing these “wet” (oil) seals with dry seals significantly reduces operating costs and methane emissions.

Methane emissions from wet seals typically range from 40 to 200 standard cubic feet per minute (scfm). Most of these emissions occur when the circulating oil is stripped of the gas it absorbs at the high-pressure seal face. Dry seals, which use high-pressure gas to seal the compressor, emit less natural gas (up to 6 scfm), have lower power requirements, improve compressor and pipeline operating efficiency and performance, enhance compressor reliability, and require significantly less maintenance.

Although dry seal conversions might not be possible on some compressors because of housing design or operational requirements, partners should select dry seals over wet seals whenever they replace or install centrifugal compressors where possible. A dry seal can save about \$315,000 per year and pay for itself in as little as 11 months. One Natural Gas STAR partner who installed a dry seal on an existing compressor, for example, reduced emissions by 97 percent, from 75 to 2 Mcf per day, saving almost \$187,000 per year in gas alone.

Method for Reducing Methane Emissions	Volume of Natural Gas Savings (Mcf/yr)	Value of Natural Gas Savings (\$/yr)	Cost of Implementation (\$)	Payback (months)
Replacing wet oil seals with dry seals in centrifugal compressors	45,120 ¹	\$315,840	\$324,000 ²	10 ³

¹ Based on the difference between typical vent rates of wet and dry seals (i.e., 100 scfm versus 6 scfm) on a “beam” type compressor operating 8,000 hrs/yr.

² Value of gas = \$7.00/Mcf.

³ Based on replacement of a fully functioning wet seal with additional \$102,400 in O&M cost reductions.

Wet Seals

Centrifugal compressors require seals around the rotating shaft to prevent gases from escaping where the shaft exits the compressor casing. The more common “beam” type compressors have two seals, one on each end of the compressor, while “over-hung” compressors have a seal on only the “inboard” (motor) side. As shown in Exhibit 1, these seals use oil, which is circulated under high pressure between three rings around the compressor shaft, forming a barrier against the compressed gas leakage. The center ring is attached to the rotating shaft, while the two rings on each side are stationary in the seal housing, pressed against a thin film of oil flowing between the rings to both lubricate and act as a leak barrier. “O-ring” rubber seals prevent leakage around the stationary rings. Very little gas escapes through the oil barrier; considerably more gas is absorbed by the oil under the high pressures at the “inboard” (compressor side) seal oil/gas interface, thus contaminating the seal oil. Seal oil is purged of the absorbed gas (using heaters, flash tanks, and degassing techniques) and recirculated. The recovered methane is commonly vented to the atmosphere.

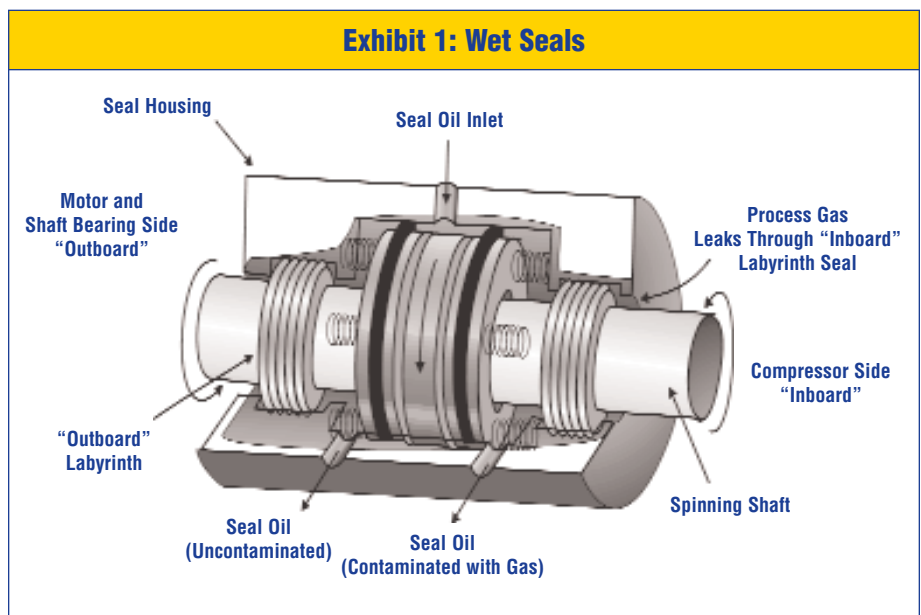

Dry Seals

An alternative to the traditional wet (oil) seal system is the mechanical dry seal system. This seal system does not use any circulating seal oil. Dry seals operate mechanically under the opposing force created by hydrodynamic grooves and static pressure.

As shown in Exhibits 2a and 2b, hydrodynamic grooves are etched into the surface of the rotating ring affixed to the compressor shaft. When the compressor is not rotating, the stationary ring in the seal housing is pressed against the rotating ring by springs. When the compressor shaft rotates at high speed, compressed gas has only one pathway to leak down the shaft, and that is between the rotating and stationary rings. This gas is pumped between the rings by grooves in the rotating ring.

The opposing force of high-pressure gas pumped between the rings and springs trying to push the rings together creates a very thin gap between the rings through which little gas can leak. While the compressor is operating, the rings are not in contact with each other, and therefore, do not wear or need lubrication. O-rings seal the stationary rings in the seal case.

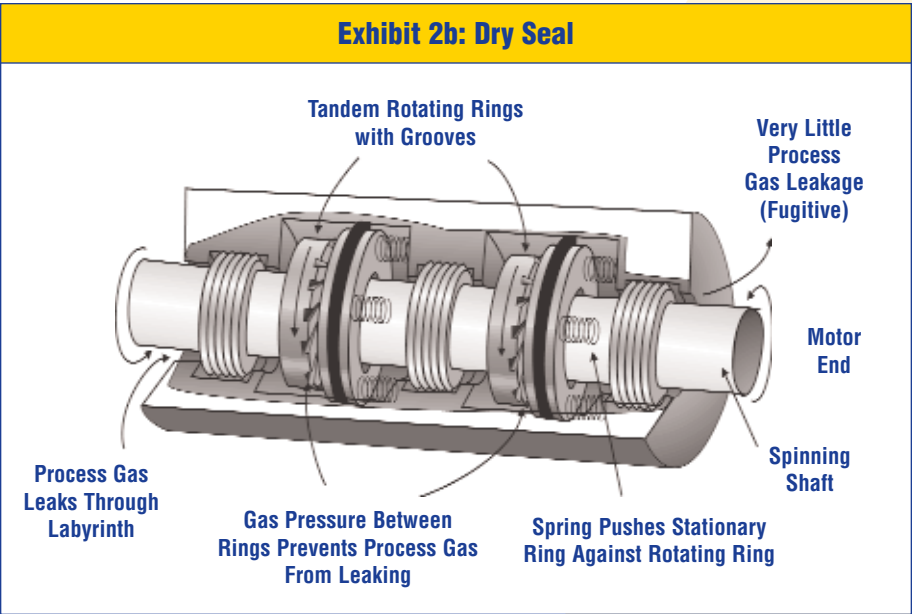
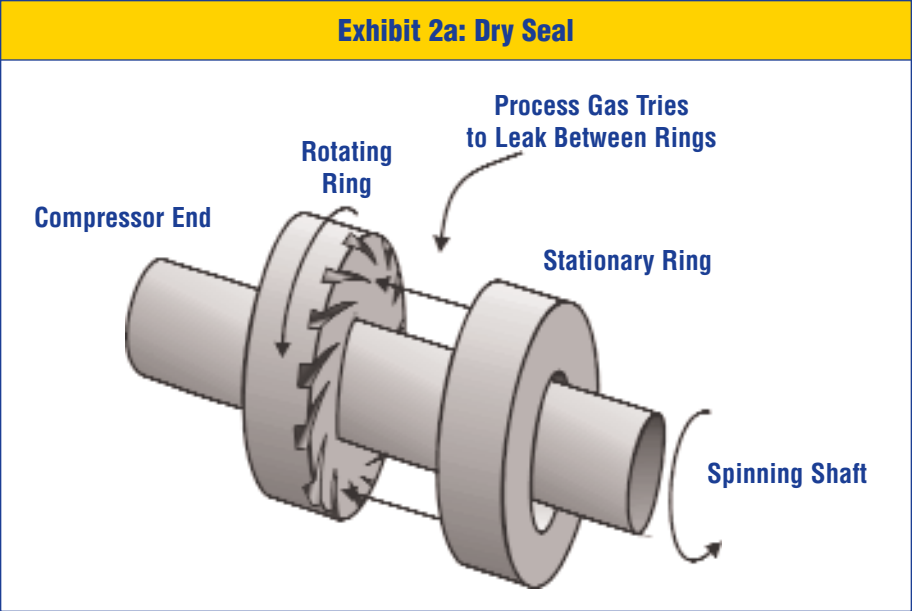

Economic and Environmental Benefits

Putting two or more of these dry seals together in series, as shown in Exhibit 2b, is called “tandem dry seals,” and is very effective in reducing gas leakage. This type of seal has less than one percent of the leakage of a wet seal system vented into the atmosphere and costs considerably less to operate.

Dry gas seals substantially reduce methane emissions. At the same time, they significantly reduce operating costs and enhance compressor efficiency. Economic and environmental benefits of dry seals include:

- ★ **Gas Leak Rates.** During normal operation, dry seals leak at a rate of 0.5 to 3 scfm across each seal, depending on the size of the seal and operating pressure. While this is equivalent to a wet seal’s leakage rate at the seal face, wet seals generate additional emissions during degassing of the circulating oil. Gas from the oil is usually vented to the atmosphere, bringing the total leakage rate for dual wet seals to between 40 and 200 scfm, depending on the size and pressure of the compressor.
- ★ **Mechanically Simpler.** Dry seal systems do not require elaborate oil circulation components and treatment facilities.
- ★ **Reduced Power Consumption.** Because dry seals have no accessory oil circulation pumps and systems, they avoid “parasitic” equipment power losses. Wet systems require 50 to 100 kW per hour, while dry seal systems need about 5 kW of power per hour.
- ★ **Improved Reliability.** The highest percentage of downtime for a compressor using wet seals is due to seal system problems. Dry seals have fewer ancillary components, which translates into higher overall reliability and less compressor downtime.
- ★ **Lower Maintenance.** Dry seal systems have lower maintenance costs than wet seals because they do not have moving parts associated with oil circulation (e.g., pumps, control valves, relief valves).
- ★ **Elimination of Oil Leakage from Wet Seals.** Substituting dry seals for wet seals eliminates seal oil leakage into the pipeline, thus avoiding contamination of the gas and degradation of the pipeline.

Decision Process

Partners usually face one of three situations when considering installation of dry seals: they are replacing an entire compressor; they are replacing a worn-out wet seal at an existing compressor; or they are replacing a fully functioning wet seal at an existing compressor. About 90 percent of all new compressors come with dry seals. When purchasing a new compressor, partners should be sure that it includes a dry seal.

The analysis for replacing a wet seal on an existing compressor should consider the methane emissions savings along with capital and operational costs and benefits. The economics for replacing operating wet seals are compelling, and wherever possible, partners should undertake such replacements. The decision process below is a guideline for determining candidates, benefits, and costs for replacing wet seals with dry seals in compressors.

Four Steps for Converting to Dry Seals:

1. Identify candidates for wet seal replacement.
2. Estimate the savings of a dry seal retrofit.
3. Determine the costs for conversion to dry seals.
4. Compare costs to savings.

Step 1: Identify candidates for wet seal replacement. Operators should make a comprehensive inventory and technical evaluation of their existing compressors. Factors to consider include compressor type, age, hardware, and operating conditions. All wet seal compressors should be identified and evaluated for dry seals. When deciding which compressors are candidates for replacement of the wet seal, consider the following:

- ★ Dry seals can be used for compressors up to 3,000 psi safely; applications of 1,500 psi are routine. Dry seals, however, might not be safe for higher pressures. Further, dry seals are not appropriate for applications with temperatures above 300 to 400 degrees Fahrenheit (due to O-ring material limitations)¹. Some compressor designs prohibit the retrofit of dry seals.
- ★ Some older compressors might be at the end of their economic life and, thus, are candidates for complete replacement rather than a seal replacement. This is usually determined while planning a major overhaul, when operating and maintenance (O&M) costs for the old compressor are projected to increase to a level much greater than O&M costs for a new unit. Some clues that this stage might have been reached include sudden increases in the frequency and magnitude of unscheduled maintenance and the unavailability of replacement parts or lack of technical support.

Centrifugal compressors that meet the Step 1 criteria should be evaluated further as follows.

Step 2: Estimate the savings of a dry seal retrofit. In general, the majority of savings from replacing a wet seal with a dry seal are attributable to reductions in methane gas loss. To estimate these savings, partners can measure the majority of methane loss from their wet seal compressors at the vent from the seal oil degassing unit by bagging or using a high flow sampler. Some gas also escapes at the seal face, but this is more difficult to measure

¹John Stahley, Dresser-Rand Co.

and amounts to less than 10 percent of emissions from the seal oil degassing unit. Typical wet gas seal leakage ranges from 40 to 200 scfm for a beam type compressor.

Methane Content of Natural Gas

Pipeline quality natural gas found in the transmission sector contains approximately 93% methane. Methane emission reductions can be approximated by applying the methane content of pipeline quality gas to the natural gas savings calculated in this document.

By comparison, expected losses from dry seals can be seen in Exhibit 3, a performance chart provided by a dry seal vendor. This chart shows an example of one type of tandem seal with leak rates ranging between 0.5 to 3 scfm for 1.5 to 10 inch compressor shafts, for compressors operating at 580 to 1,300 psig pressure. Replacing the wet seal with two tandem dry seals can reduce emissions between 34 to 194 scfm. This is equivalent to 16,320 to 93,120 Mcf per 8,000-hour year, with total annual savings of \$114,240 to \$651,840.

This process is applicable to all compressor designs. The less common overhung compressors have a single seal, and switching from wet to dry seals would yield half the savings of doing the same for a beam type compressor.

Exhibit 3: Dry Seal Performance Chart

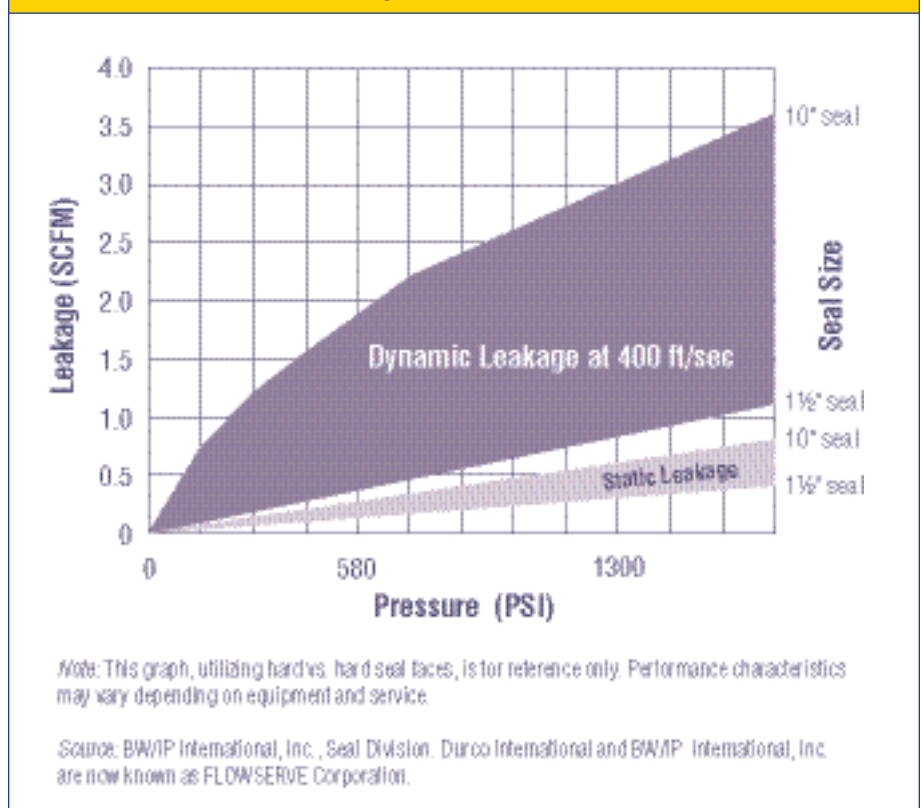

Beyond gas savings, dry seals also yield significant operational and maintenance savings compared with wet seals. Annual O&M costs for dry seals range widely, between \$8,400 and \$14,000 per year. Wet seal O&M costs can reach up to \$140,000 per year. Detailed calculations of the differences in O&M costs between dry and wet seals are well documented (see Uptigrove et al., 1987). Exhibit 4 summarizes these estimates for a compressor with a 7.5-inch shaft diameter, operating 8,000 hours per year.

Exhibit 4: Dry Seal Annual O&M Costs Savings per Compressor¹	
1. Reduced seal power losses =	\$19,500
2. Reduced oil pump/fan losses=	\$5,600
3. Increased pipeline flow efficiency =	\$37,300
4. Reduced oil losses =	\$4,900
5. Reduced O&M, downtime =	\$21,000
TOTAL SAVINGS = \$88,300	
¹ S.O. Uptigrove et al., adjusted to 2006 operating and maintenance costs.	

Site specific factors used in the calculations include: (1) wet and dry seal drag losses, (2) seal oil pump and cooling fan horsepower, (3) compressor horsepower, (4) seal oil consumption, and (5) annual emergency and scheduled maintenance costs.

Step 3: Determine the costs for conversion to dry seals. The cost for a dry seal system will depend on compressor operating pressure, shaft size, rotation speed, and other installation-specific factors. Costs for the seal typically range between \$6,750 and \$8,100 per inch of shaft diameter for wet seals and \$10,800 to \$13,500 per inch for tandem dry seals. These costs will double for beam type compressors (two seals).

Nelson Price Indexes

In order to account for inflation in equipment and operating & maintenance costs, Nelson-Farrar Quarterly Cost Indexes (available in the first issue of each quarter in the *Oil and Gas Journal*) are used to update costs in the Lessons Learned documents.

The “Refinery Operation Index” is used to revise operating costs while the “Machinery: Oilfield Itemized Refining Cost Index” is used to update equipment costs.

To use these indexes in the future, simply look up the most current Nelson-Farrar index number, divide that by the February 2006 Nelson-Farrar index number, and, finally, multiply by the appropriate costs in the Lessons Learned.

Other costs include engineering, installation and ancillary equipment. Dry seals require a gas console, filtration unit, controls, and monitoring instruments, while wet seals require the seal oil pumps, fan coolers, degassing unit,

and controls. Depending on location, type of equipment, number of controls, and availability of components, costs range from \$40,500 to \$135,000 for dry seals, and up to \$270,000 for wet seals. These ancillary facility costs are the same for both the single and dual seal compressor types.

Step 4: Compare costs to savings. A simple cost comparison between converting a compressor to dry seals and replacing existing wet seals with new components will show substantial savings over a five-year period. Exhibit 5 shows an example for a beam type compressor with a 6-inch shaft operating for 8,000 hours per year using the costs from Steps 2 and 3.

In this example, implementation costs for a conversion to dry seals include the cost of both the seals and the dry gas conditioning, monitoring, and control console. For wet seals, the seal oil circulation, degassing, and cooling ancillary facilities are reused, so only seal replacement costs are incurred.

Exhibit 5: Cost Comparison for 6-Inch Shaft Beam Type Compressor Seal Replacement		
Cost Category	Dry Seal (\$)	Wet Seal (\$)
Implementation Costs¹		
Seal costs (2 dry @ \$13,000/shaft-inch, w/testing)	162,000	
Seal costs (2 wet @ \$6,750/shaft-inch)		81,000
Other costs (engineering, equipment installation)	162,000	0 ²
Total Implementation Costs	324,000	81,000
Annual O&M ³	14,100	102,400
Annual methane emissions ⁴ (@ \$7.00/Mcf; 8,000 hrs/yr)		
2 dry seals at a total of 6 scfm	20,160	
2 wet seals at total 100 scfm		336,000
Total Costs Over 5-Year Period (\$):	495,300	2,273,000
Total Dry Seal Savings Over 5 Years:		
Savings (\$)	1,777,700	
Methane Emissions Reductions (Mcf) (at 45,120 Mcf/yr)	225,600	
¹ Flowserve Corporation, adjusted to 2006 equipment costs. ² Re-use existing seal oil circulation, degassing, and control equipment. ³ From Exhibit 4; assumes same O&M cost as 7.5-inch shaft. ⁴ Based on typical vent rates.		

Estimated Savings

Another way of illustrating the economics of this practice is through a five year cash flow table. This analysis considers capital costs, methane emissions savings, operating and maintenance costs, and assigns a salvage value to the wet seal system. It is important to note that all analyses will be highly site-specific, but the economics of a dry seal retrofit are so attractive that companies should consider replacing all wet seals, regardless of age. Exhibit 6A presents the economics of replacing a fully functional wet seal system with a dry seal system.

Exhibit 6A: Economics of Replacing a Fully Functional Wet Seal System with a New Dry Seal System						
Retrofit of dry gas seals on a “beam” type compressor, 6-inch shaft, operating 8,000 hours per year, with fully functional wet seals.						
Costs and Savings (\$)	Year 0	Year 1	Year 2	Year 3	Year 4	Year 5
Dry seal capital & installation costs	(324,000)					
Annual natural gas savings ¹		315,840	315,840	315,840	315,840	315,840
Dry seal annual O&M Costs		(14,100)	(14,100)	(14,100)	(14,100)	(14,100)
Wet seal salvage value	20,000					
Avoided wet seal O&M Cost		102,400	102,400	102,400	102,400	102,400
Annual Totals	(304,000)	404,140	404,140	404,140	404,140	404,140
NPV (Net Present Value)² = \$1,228,009 IRR (Internal Rate of Return) = 131% Payback Period³ = 10 months						
¹ Annual savings represent the difference of natural gas loss between new dry seals and replaced wet seals, at \$7.00/Mcf. ² Net present value based on 10% discount over five years. ³ Payback period ranges between 3 and 12 months for wet seal leakage rates between 200 and 40 scfm.						

Exhibit 6B shows the economics for replacing an old wet seal nearing the end of its useful life: salvage value is zero and annual O&M costs for the wet seal system increase (in this example, to \$140,000 per year). These two examples demonstrate that replacing a wet seal with a dry seal can be cost effective regardless of the age or condition of the wet seal system.

Exhibit 6B: Economics of Replacing an Aging Wet Seal System with a New Dry Seal System						
Retrofit of dry gas seals on a “beam” type compressor, 6-inch shaft, operating 8,000 hours per year, with wet seals needing replacement.						
Costs and Savings (\$)	Year 0	Year 1	Year 2	Year 3	Year 4	Year 5
Dry seal capital & installation costs	(324,000)					
Annual natural gas savings ¹		315,840	315,840	315,840	315,840	315,840
Dry seal annual O&M Costs		(14,100)	(14,100)	(14,100)	(14,100)	(14,100)
Wet seal salvage value	0					
Avoided wet seal O&M Cost		140,000	140,000	140,000	140,000	140,000
Annual Totals	(324,000)	441,740	441,740	441,740	441,740	441,740
NPV (Net Present Value)² = \$1,350,542						
IRR (Internal Rate of Return) = 134%						
Payback Period³ = 9 months						
<small>1. Annual savings represent the difference of natural gas loss between new dry seals and replaced wet seals, at \$7.00/Mcf. 2. Net present value based on 10% discount over five years.</small>						

When assessing options for replacing wet seals with dry seals in centrifugal compressors, natural gas price may influence the decision making process. Exhibit 7 shows an economic analysis of early replacement of wet seals in a centrifugal compressor with dry seals at different natural gas prices.

Exhibit 7: Gas Price Impact on Economic Analysis					
	\$3/Mcf	\$5/Mcf	\$7/Mcf	\$8/Mcf	\$10/Mcf
Value of Gas Saved	\$135,360	\$225,600	\$315,840	\$360,960	\$451,200
Payback Period (Months)	17	12	10	9	7
Internal Rate of Return (IRR)	68%	100%	131%	146%	176%
Net Present Value (i=10%)	\$543,847	\$885,928	\$1,228,009	\$1,399,049	\$1,741,129

Lessons Learned

Partners can achieve significant cost savings and emissions reductions by converting to dry seal technology. Partners offer the following lessons learned when changing to dry seals:

- ★ Dry seals are considered safer to operate than wet seals, because they eliminate the need for a high pressure oil system.
- ★ To make the switch to dry seals most efficiently, schedule the conversion for a normal downtime period to avoid disrupting operations.
- ★ When determining the benefits of a seal replacement, partners should take into account that properly installed and maintained dry seals can last more than twice as long as wet seals.
- ★ If the wet seal is near the end of its useful life, a straightforward cost analysis between new seal systems will favor the dry seal. Even if the existing wet seal has substantial remaining useful life, the operational characteristics of dry seals will provide significant savings and could justify early replacement.
- ★ Given the clear economic advantages of dry seals, they should be installed wherever it is technically feasible.
- ★ Ninety percent of all new compressors now have dry gas seal systems. Dry seals should be the technology of choice for all new compressors.
- ★ After replacing wet seals with dry seals, record emissions reductions in annual reports submitted as part of the Natural Gas STAR Program.

References

Canadian Association of Petroleum Producers. *Options for Reducing Methane and VOC Emissions from Upstream Oil and Gas Operations*. December 1993.

Henderson, Carolyn. U.S. EPA Natural Gas STAR Program. Personal contact.

Hesje, R.C. and R.A. Peterson. *Mechanical Dry Seal Applied to Pipeline (Natural Gas) Centrifugal Compressors*. American Society of Mechanical Engineering. Gas Turbine Conference and Exhibition. June 1984.

Kennedy, J.L. *Oil and Gas Pipeline Fundamentals*, Second Edition. PennWell Books. 1993.

Klosek, Marty. Flowserve Corporation. Bridgeport, New Jersey. Personal contact.

Ronsky, N. Daryl; Harris, T.A.; Conquergood, C. Peter; and Davies, I. *An Effective System for Sealing Toxic Gases in Centrifugal Compressors*. American Society of Mechanical Engineers Gas Turbine Conference and Exhibition. June 1987.

Sears, John. Personal contact.

Stahley, John. Dresser-Rand Company. Olean, New York. Personal contact.

Tingley, Kevin. U.S. EPA Natural Gas STAR Program. Personal contact.

Uptigrove, S.O.; Harris, T.A.; and Holzner, D.O. *Economic Justification of Magnetic Bearings and Mechanical Dry Seals for Centrifugal Compressors*. American Society of Mechanical Engineers Gas Turbine Conference and Exhibition. June 1987.

1EPA

United States
Environmental Protection Agency
Air and Radiation (6202J)
1200 Pennsylvania Ave., NW
Washington, DC 20460

EPA xxx
xxx 2006