

EPA/600/R-09/123
September 2009
09/32/WQPC-SWP

Environmental Technology Verification Report

UV Disinfection for Secondary Effluent and Reuse Applications

Siemens Water Technologies Corp.
Barrier Sunlight H-4XE-HO Open
Channel UV System

Prepared by



NSF International

Under a Cooperative Agreement with

 U.S. Environmental Protection Agency

ET ✓ ET ✓ ET ✓

Environmental Technology Verification Report

Verification of Ultraviolet (UV) Disinfection for Secondary Effluent and Reuse Applications

Siemens Water Technologies H-4XE-HO (2W-1B-1C) Open Channel UV System

Prepared for

NSF International
Ann Arbor, MI 48105

Prepared by

HydroQual, Inc.
Mahwah, NJ 07430

Under a cooperative agreement with the U.S. Environmental Protection Agency

Raymond Frederick, Project Officer
ETV Source Water Protection Pilot
National Risk Management Research Laboratory
Water Supply and Water Resources Division
U.S. Environmental Protection Agency
Edison, New Jersey 08837

September 2009

NOTICE

The U.S. Environmental Protection Agency (USEPA) through its Office of Research and Development has financially supported and collaborated with NSF International (NSF) under a Cooperative Agreement. The Water Quality Protection Center, Source Water Protection area, operating under the Environmental Technology Verification (ETV) Program, supported this verification effort. This document has been peer reviewed and reviewed by NSF and USEPA and recommended for public release.

FOREWORD

The U.S. Environmental Protection Agency (EPA) is charged by Congress with protecting the Nation's land, air, and water resources. Under a mandate of national environmental laws, the Agency strives to formulate and implement actions leading to a compatible balance between human activities and the ability of natural systems to support and nurture life. To meet this mandate, EPA's research program is providing data and technical support for solving environmental problems today and building a science knowledge base necessary to manage our ecological resources wisely, understand how pollutants affect our health, and prevent or reduce environmental risks in the future.

The National Risk Management Research Laboratory (NRMRL) is the Agency's center for investigation of technological and management approaches for preventing and reducing risks from pollution that threaten human health and the environment. The focus of the Laboratory's research program is on methods and their cost-effectiveness for prevention and control of pollution to air, land, water, and subsurface resources; protection of water quality in public water systems; remediation of contaminated sites, sediments and ground water; prevention and control of indoor air pollution; and restoration of ecosystems. NRMRL collaborates with both public and private sector partners to foster technologies that reduce the cost of compliance and to anticipate emerging problems. NRMRL's research provides solutions to environmental problems by: developing and promoting technologies that protect and improve the environment; advancing scientific and engineering information to support regulatory and policy decisions; and providing the technical support and information transfer to ensure implementation of environmental regulations and strategies at the national, state, and community levels.

This publication has been produced as part of the Laboratory's strategic long-term research plan. It is published and made available by EPA's Office of Research and Development to assist the user community and to link researchers with their clients.

The following is the final report on an Environmental Technology Verification (ETV) test performed for NSF International (NSF) and the United States Environmental Protection Agency (USEPA) by HydroQual, Inc. The verification test for the Siemens Water Technologies H-4XE-HO (2W-1B-1C) Open Channel UV Disinfection System was conducted from 9/05/08 to 10/07/08 at the Gloversville Johnstown Waste Water Treatment Facility (GJWWTF) located in Johnstown, New York.

CONTENTS

NOTICE.....	i
FOREWORD.....	ii
FIGURES.....	vi
APPENDICES.....	ix
GLOSSARY AND DEFINITIONS.....	x
ABBREVIATIONS AND ACRONYMS.....	xii
EXECUTIVE SUMMARY.....	1
1 INTRODUCTION AND BACKGROUND.....	1-1
1.1 THE ETV PROGRAM.....	1-1
1.1.1 Concept of the ETV Program.....	1-1
1.1.2 The ETV Program for Water Reuse and Secondary Effluent Disinfection.....	1-1
1.1.3 The Siemens Water Technologies ETV.....	1-2
1.2 MECHANISM OF UV DISINFECTION.....	1-2
1.2.1 Practical Application of UV Disinfection.....	1-2
1.2.2 A Comparison of UV and Chemical Disinfection.....	1-3
1.2.3 Determining Dose Delivery.....	1-4
1.2.4 Summary of the Biosimetric Method to Measure Dose.....	1-5
2 ROLES AND RESPONSIBILITIES OF PARTICIPANTS IN THE VERIFICATION TESTING.....	2-1
2.1 NSF INTERNATIONAL (NSF).....	2-1
2.2 U.S. ENVIRONMENTAL PROTECTION AGENCY (USEPA).....	2-2
2.3 Field TESTING ORGANIZATION (FTO), HYDROQUAL, INC.....	2-2
2.4 Validation test facility.....	2-3
2.5 UV TECHNOLOGY VENDOR – Siemens water technologies.....	2-6
3 TECHNOLOGY DESCRIPTION.....	3-1
3.1 Siemens water technologies open channel UV DISINFECTION SYSTEM.....	3-1
3.1.1 Lamps and Sleeves.....	3-2
3.1.2 Lamp Output Attenuation by Aging and Sleeve Fouling.....	3-2
3.1.3 Sleeve Cleaning System.....	3-2
3.1.4 Electrical Controls.....	3-2
3.1.5 UV Detectors.....	3-2
3.1.6 Design Operational Envelope.....	3-3
3.2 UV TEST STAND SPECIFICATIONS.....	3-3
3.2.1 Test Channel.....	3-3
3.3 VERIFICATION TEST CLAIMS.....	3-5
4 PROCEDURES AND METHODS USED DURING VERIFICATION TESTING.....	4-1
4.1 General Technical Approach.....	4-1
4.1.1 Site Preparation.....	4-1
4.1.2 Water Source.....	4-2
4.1.3 Challenge Water and Discharge Tanks.....	4-3
4.1.4 Feed Pumps.....	4-3
4.1.5 Flow Meter.....	4-3
4.2 DISINFECTION UNIT STARTUP AND CHARACTERIZATION.....	4-3
4.2.1 100 Hour Lamp Burn-In.....	4-3

4.2.2	Power Consumption and Flow Characterization.....	4-3
4.3	BActeriophage PRODUCTION AND CALIBRATION.....	4-5
4.3.1	Bacteriophage Propagation.....	4-5
4.3.2	Dose-Response Determination.....	4-6
4.4	BIODOSIMETRIC FIELD TESTS.....	4-8
4.4.1	Lamp Sleeve Preparation.....	4-8
4.4.2	Challenge Water Batch Preparation.....	4-9
4.4.3	Biodosimetric Flow Tests.....	4-9
4.4.4	Transmittance Measurement.....	4-9
4.4.5	Bacteriophage Enumeration.....	4-9
4.4.6	Dose Determination.....	4-10
4.5	EXPERIMENTAL TEST MATRIX.....	4-10
5	RESULTS AND DISCUSSION.....	5-12
5.1	DISINFECTION UNIT STARTUP AND CHARACTERIZATION.....	5-12
5.1.1	Power Consumption.....	5-12
5.1.2	Headloss Measurements.....	5-12
5.1.3	Intensity Sensor Characterization.....	5-13
5.1.4	Velocity Profile Measurements.....	5-16
5.2	Bacteriophage DOSE-RESPONSE CALIBRATION CURVES.....	5-18
5.2.1	Dose-Response Results.....	5-18
5.2.2	Dose-Response Calibration Curve.....	5-18
5.2.3	Collimated Beam Uncertainty.....	5-26
5.3	DOSE-FLOW ASSAYS.....	5-27
5.3.1	Intensity Attenuation Factor.....	5-27
5.3.2	Flow Test Data and Results Summary.....	5-28
5.3.3	Biodosimetric Data Analysis – RED Algorithm.....	5-31
5.3.4	Sensor Model.....	5-33
6	QUALITY ASSURANCE/QUALITY CONTROL.....	6-1
6.1	CALIBRATIONS.....	6-1
6.1.1	Flow Meter Calibration.....	6-1
6.1.2	Spectrophotometer Calibration.....	6-2
6.1.3	UV Intensity Sensors.....	6-5
6.1.4	Radiometer Calibration.....	6-5
6.2	QA/QC OF MICROBIAL SAMPLES.....	6-5
6.2.1	Reactor Controls.....	6-5
6.2.2	Reactor Blanks.....	6-7
6.2.3	Trip Controls.....	6-8
6.2.4	Flow Test Sample Replicates.....	6-8
6.2.5	Transmittance Replicates.....	6-9
6.2.6	Method Blanks.....	6-10
6.2.7	Stability Samples.....	6-10
6.2.8	Collimated-Beam Apparatus.....	6-11
6.3	DOSE-RESPONSE DATA.....	6-12
6.3.1	Excluded Data.....	6-12
6.3.2	MS2 Compliance with QC Boundaries.....	6-12
6.3.3	Uncertainty in Dose Response.....	6-13

7	CALCULATION OF THE VALIDATION FACTOR FOR RED AND LOG-INACTIVATION DESIGN SIZING	7-1
	7.1 DISINFECTION CREDIT IN ACCORDANCE WITH CURRENT PROTOCOLS.....	7-1
	7.1.1 Validated Dose (D_v) and Targeted Disinfection.....	7-1
	7.2 DETERMINATION OF THE VALIDATION FACTOR ELEMENTS	7-2
	7.2.1 RED Bias (B_{RED})	7-2
	7.2.2 Polychromatic Bias (B_{POLY})	7-3
	7.2.3 Validation Uncertainty (U_{val}).....	7-3
	7.2.4 Calculation of the Validation Uncertainty (U_{val}).....	7-5
	7.3 CALCULATION OF THE VALIDATION FACTOR.....	7-5
	7.3.1 Validation Factor (VF).....	7-5
	7.4 VALIDATED RED AND LOG INACTIVATION.....	7-7
8	EXAMPLE CALCULATIONS FOR SIZING The Siemens H-4XE-HO (2W-1B-1C)	8-1
	8.1 DESIGN CONDITIONS FOR EXAMPLE APPLICATIONS	8-1
	8.1.1 Application 1	8-1
	8.1.2 Application 2	8-4
9	REFERENCES	9-1

FIGURES

<u>Figure</u>	<u>Page</u>
Figure E-1. MS2, T1 and Q β RED as a Function of UVT and Flow/Lamp	E-4
Figure E-2. Sensor Model Prediction as a Function of UVT	E-5
Figure E-3. Algorithm Calculated RED versus Observed RED	E-7
Figure E-4. Example Solutions for Validation Factor at Fixed Operating Conditions and a Range of UV Sensitivities.....	E-8
Figure E-5. Credited RED at 50% UVT Across a Range of UV Sensitivities.....	E-9
Figure E-6. Example Fecal Coliforms Dose-Responsive Curve.....	E-12
Figure E-7. Example Calculation of RED as a Function of Flow (55% UVT) for a H-4XE-HO (2W-1B-1C) Reactor in a Low-Dose Application.....	E-13
Figure E-8. Example Calculation of RED as a Function of Flow (55% UVT) for a H-4XE-HO (2W-1B-1C) Reactor in a Reuse Application	E-14
Figure 2-1. Project Organization Chart	2-1
Figure 2-2. Aerial View of the Gloversville-Johnstown Joint Wastewater Treatment Facility and the UV Center	2-4
Figure 2-3. Aerial View of the UV Center Tanks	2-4
Figure 2-4. General Schematic of the UV Test Facility Showing Major Test Stands (Tank 4 not shown).....	2-5
Figure 3-1. Plan and Elevation Schematic of H-4XE-HO (2W-1B-1C) Reactor and Channel Assembly.....	3-1
Figure 3-2. Influent (Top) and Effluent (Bottom) Piping Configuration for the H-4XE-HO (2W-1B-1C) Test Unit Channel.....	3-4
Figure 3-3. Influent Stilling Plate and Effluent Weir Gate for the Siemens H-4XE-HO (2W-1B-1C) UV Unit Test Channel	3-6
Figure 3-4. Photos of H-4XE-HO (2W-1B-1C) Reactor Installed in Channel.....	3-7
Figure 3-5. Photo of Unit Power Panel.....	3-8
Figure 4-1. Process Flow Diagram for the H-4XE-HO (2W-1B-1C) UV System Validation Test Stand.....	4-2
Figure 4-2. Velocity Profile Measurement Matrix	4-5
Figure 4-3. HydroQual Collimating Apparatus for Conducting Dose Response Tests.....	4-7
Figure 5-1. Headloss Through a Single H-4XE-HO (2W-1B-1C) Reactor as a Function of Flow Rate	5-13
Figure 5-2. Relationship of Sensor Output (mA) and PLC Sensor Reading (%).....	5-14
Figure 5-3. Sensor Reading (mA) as a Function of UVT	5-15
Figure 5-4. Velocity Profile at 0.2 mgd.....	5-17
Figure 5-5. Velocity Profile at 0.8 mgd.....	5-17
Figure 5-6. An Example of N ₀ determination (09/25/08 Dose-Response Data).....	5-22
Figure 5-7. An Example of a Dose-Response Regression Analysis for MS2	5-22
Figure 5-8. MS2 Dose-Response Calibration Curves.....	5-23
Figure 5-9. T1 Dose-Response Calibration Curves	5-24
Figure 5-10. Q β Dose-Response Calibration Curves	5-24
Figure 5-11. Example of Dose-Response Curve-Fit Residuals Analysis	5-25
Figure 5-12. Dose-Response Curve-Fit Uncertainty (UDR)	5-27
Figure 5-13. MS2, T1 and Q β RED as a Function of UVT and Flow.....	5-30
Figure 5-14. MS2, T1 and Q β RED as a Function of UVT and Flow/Lamp	5-31
Figure 5-15. Algorithm-Calculated RED versus Observed RED.....	5-33
Figure 5-16. Sensor Model Prediction as a Function of UVT	5-34

Figure 6-1.	12-in. Flow Meter Calibration Data and Correction Formula	6-2
Figure 6-2.	Dose-Response Data and NWRI QA/QC Boundary Lines.....	6-13
Figure 7-1.	UVal Decision Tree for Calculated Dose Approach.....	7-3
Figure 7-2.	Example Solutions for Validation Factor at Fixed Operating Conditions and a Range of UV Sensitivity	7-6
Figure 7-3.	Credited RED at 50% UVT Across a Range of UV Sensitivities.....	7-8
Figure 8-1.	Example Fecal Coliforms Dose-Response Curve.....	8-2
Figure 8-2.	Example Calculation of RED as a Function of Flow (55% UVT)	8-4
Figure 8-3.	Example Calculation of RED as a Function of Flow (55% UVT) for a H-4XE-HO (2W-1B-1C) Reactor Module in a Reuse Application.....	8-5

TABLES

<u>Table</u>		<u>Page</u>
Table E-1.	H-4XE-HO (2W-1B-1C) Dose-Algorithm Regression Constants.....	E-6
Table E-2.	Credited RED Solutions.....	E-10
Table 4-1	Validation Conditions for Siemens H-4XE-HO (2W-1B-1C) UV System	4-11
Table 5-1.	Depth Measurements to Compute Headloss	5-12
Table 5-2.	Sensor Intercomparison Variance Analysis	5-16
Table 5-3.	Dose-Response Data	5-19
Table 5-4.	Summary of Dose-Response Curve Regression Parameters	5-25
Table 5-5.	MS2 Biodosimetry Tests: Delivered RED and Operations Data.....	5-29
Table 5-6.	T1 Biodosimetry Tests: Delivered RED and Operations Data	5-29
Table 5-7.	Q β Biodosimetry Tests: Delivered RED and Operations Data	5-30
Table 5-8.	H-4XE-HO (2W-1B-1C) Dose-Algorithm Regression Constants.....	5-32
Table 6-1.	12-in. Flow Meter Calibration	6-1
Table 6-2.	Wavelength and Absorbance Checks.....	6-3
Table 6-3.	Comparison of Dual Radiometer Readings for Collimated Beam Measurements	6-6
Table 6-4.	Reactor Control Sample Summary	6-7
Table 6-5.	Similarity between Replicate Flow Test Samples	6-7
Table 6-6.	Summary of Reactor Blank and Trip Control Sample Analyses	6-7
Table 6-7.	Results from Flow Test Replicates	6-9
Table 6-8.	Relative Percent Difference for %T Replicates	6-10
Table 6-9.	Phage Stability Sample Summary.....	6-10
Table 7-1.	Credited RED Solutions.....	Error! Bookmark not defined.

APPENDICES

- APPENDIX A Verification Test Plan for the Siemens Water Technologies V-40R-A150 H and H-4XE-HO (2W-1B-1C) Open Channel UV Systems for Reuse and Secondary Effluent Applications, V 2.1.
- APPENDIX B Operation and Maintenance Manual for the Siemens Water Technologies H-4XE-HO (2W-1B-1C) Open Channel UV System.
- APPENDIX C Master Data -- Siemens Water Technologies H-4XE-HO (2W-1B-1C) Reuse and Secondary Effluent Testing Program.

GLOSSARY AND DEFINITIONS

Accuracy - A measure of the closeness of an individual measurement or the average of a number of measurements to the true value and includes random error and systematic error.

Bacteriophage – A virus that has a bacterium as its host organism.

Dose – A total amount of germicidal energy deposited into a solution to be disinfected. Units are usually mJ/cm^2 (millijoules per square centimeter).

Effective disinfection zone - The zone in a disinfection lamp assembly where the UV intensity deposits a disinfecting dose into the solution. This zone is exclusive of mounting hardware on the end of the lamp sleeves and the submerged ballasts.

End-of-lamp-life (EOLL) - The UV output condition (i.e. intensity) that is present after the manufacturers recommended maximum life span for the lamps and the maximum fouling on the quartz sleeves.

Environmental Technology Verification (ETV) - A program initiated by the USEPA to use objective, third-party tests to quantitatively verify the function or claims of environmental technology.

Monochromatic – A light output spectrum that consists solely or dominantly of a single specific wavelength of light.

pfu - Plaque forming units. A single plaque-forming unit is assumed to represent one viable MS2 bacteriophage organism.

Polychromatic – A light output spectrum containing many specific wavelengths of light or a continuous spectrum in a range of wavelengths.

Precision - A measure of the agreement between replicate measurements of the same property made under similar conditions.

Representativeness - A measure of the degree to which data accurately and precisely represent a characteristic of a population parameter at a sampling point or for a process conditions or environmental condition.

Survival Ratio - The \log_{10} of the ratio of bacteriophage concentration in a UV dosed solution to an undosed solution. The values are typically negative numbers because the UV dosing reduces the number of the viable bacteriophage present in the solution.

Test Element – A series of tests designed by the ETV program to validate a group of related operational characteristics for a specific technology.

Titer – The specific number of viable organisms (e.g., bacteria or bacteriophage) in a given volume of solution.

Field Testing Organization (FTO) - An organization qualified to conduct studies and testing of UV disinfection equipment in accordance with the Verification Protocol.

UV Demand - UV energy that does not contribute to disinfection because of absorption by the chemicals in water.

UV or Ultraviolet Radiation - Light energy with a shorter wavelength than that of visible light in the range of 190nm to 400 nm.

Vendor - A business that assembles or sells UV Disinfection Technology.

Verification - To establish the evidence on the range of performance of equipment and/or device under specific conditions following an established protocol(s) and test plan(s).

Verification Protocol - A generic written document that clearly states the objectives, goals, and scope of the testing under the ETV Program and that establishes the minimum requirements for verification testing and for the development of a verification test plan. A protocol shall be used for reference during Manufacturer participation in the verification testing program.

Verification Report - A written document that summarizes a final report reviewed and approved by NSF on behalf of USEPA or directly by the USEPA.

Verification Test Plan (VTP) - A written document that establishes the detailed test procedures for verifying the performance of a specific technology. It also defines the roles of the specific parties involved in the testing and contains instructions for sample and data collection, sample handling and preservation, and quality assurance and quality control requirements relevant to a given test site.

ABBREVIATIONS AND ACRONYMS

ANSI	American National Standards Institute
AWWARF	American Water works Research Foundation (now WRF)
°C	Degrees Celsius
CFD	Computational Fluid Dynamics
cm	Centimeter (10^{-2} meters)
DVGW	German Technical and Scientific Association for Gas and Water
Eff	Effluent
EOLL	End-of-lamp-life
USEPA	United States Environmental Protection Agency
ETV	Environmental Technology Verification
ft	Feet
FTO	Field Testing Organization
GAC	Granular Activated Carbon
G-JJWWTF	Gloversville-Johnstown Joint Wastewater Treatment Facility
gal	gallons
gpm	gallons per minute
hr	Hour(s)
I	Intensity
in.	Inch
Inf	Influent
ISO	International Standards Organization
kW	Kilowatt
LI	Log Inactivation
L/min	Liters per minute
log	Base 10 logarithm
LPHO	Low-Pressure, High-Output (type of mercury lamp)
LRCM	Lamp Rack Controller Module
LSA	Lignon Sulfonic Acid (Lignon sulfonate)
m	Meters
mm	Millimeter (10^{-3} meters)
µm	Micrometer (10^{-6} meters)
mA	MilliAmp
mgd	Million gallons per day
mg/L	Milligrams per liter
mJ	MilliJoule
mL	Milliliters
mW	MilliWatt
nm	Nanometers (10^{-9} meters)
NIST	National Institute of Standards and Technology
NRML	National Risk Management Research Laboratory
NSF	NSF International
NTU	Nephelometric Turbidity Units
NYSERDA	New York State Energy Research and Development Authority
NWRI	National Water Research Institute

ABBREVIATIONS AND ACRONYMS (continued)

O&M	Operation and Maintenance
ORD	Office of Research and Development, USEPA
OSHA	Occupational Safety and Health Administration
PDC	Power Distribution Center
pfu	Plaque forming units
pfu/mL	Plaque forming units per milliliter
PLC	Programmable Logic Center
ppm	Parts per million
Q	Flow rate
QA	Quality Assurance
QAPP	Quality Assurance Project Plan
QC	Quality Control
QMP	Quality Management Plan
RED	Reduction Equivalent Dose
RPD	Relative Percent Difference
SAG	Stakeholders Advisory Group
SOP	Standard Operating Procedure
SWP	Source Water Protection Area, Water Quality Protection Center
TYBG	Tryptone Yeast Extract Glucose Broth
%T	Transmittance
UV	Ultraviolet
UVC	Ultraviolet Radiation in the range of 230nm to 280 nm
UVDGM	Ultraviolet Disinfection Guidance Manual
UVS	UV Sensitivity in units of dose per log inactivation
UVT	UV Transmittance
V	Volt
VF	Validation Factor
VO	Verification Organization
VR	Verification Report
VTP	Verification Test Plan
W	Watts
WQPC	Water Quality Protection Center
WRF	Water Research Foundation
WW Protocol	Wastewater Validation Protocol

EXECUTIVE SUMMARY

E.1 VALIDATION PROGRAM

E.1.1 Validation Protocols for Reuse Water Disinfection

This report documents the testing, data reduction and analysis in conformance with the recently developed test protocol, “Validation of UV Reactors for Application to the Disinfection of Treated Wastewaters” (2008, hereafter, referred to as the WW Protocol), which combines and updates the objectives and methods found in established UV disinfection guidance documents. The “Ultraviolet Disinfection Guidelines for Drinking Water and Water Reuse” by the National Water Research Institute and the American Water Works Association Research Foundation (NWRI/AwwaRF) (2003) was used as an important guidance for this validation report. The United States Environmental Protection Agency (USEPA) “UV Disinfection Guidance Manual” (UVDGM, November 2006), and the “Verification Protocol for Secondary Effluent and Water Reuse Disinfection Applications” by NSF International and the USEPA under the Environmental Technology Verification Program (ETV, 2000) were also important references.

E.1.2 Barrier Sunlight H-4XE-HO (2W-1B-1C) UV Disinfection System

The Barrier Sunlight H-4XE-HO (2W-1B-1C) UV disinfection system (H-4XE-HO (2W-1B-1C)) was tested at full-scale in a 21-ft long channel, including a power supply center and a main control panel. A perforated baffle plate was positioned downstream of the inlet to simulate reactor inlet flow conditions that are representative of commercial channel design. An adjustable weir was installed downstream of the reactor to maintain a constant, prescribed water depth inside the channel. The reactor contains 16, low-pressure, high-output (LPHO) lamps oriented horizontally and arranged in symmetrical array four lamps across and four lamps deep. Each lamp is rated for 171 W total power input. The lamps have an arc length of 59 in., and are enclosed in 28 mm outer diameter quartz sleeves, 70 in. long. The validation was conducted at full power input, and the UVT was adjusted to simulate a combined fouling and lamp aging attenuation of 80%. The reactor was equipped with one duty UV intensity sensor (PW-254), located 2 cm from the quartz surface of the nearest top lamp. The operating strategy for the H-4XE-HO (2W-1B-1C) uses lamp banks in series and parallel that are brought into service on demand, based on flow and water quality (UVT).

E.1.3 Validation Test Stand

The Barrier Sunlight H-4XE-HO (2W-1B-1C) UV disinfection unit was installed in a test channel at the UV Validation and Research Center of New York (UV Center), located in Johnstown, NY. The test channel was fed through the facility’s 12-in. feed pipe test stands, serviced by up to eight diesel-powered, centrifugal pumps. Flow direction valves, up- and downstream in-line static mixers, electromagnetic flow meter, and air-relief valves comprise key elements of the test stand, in conformance with current validation protocols. A pre-mix injection

system was connected to the test stream to facilitate the addition of challenge microorganisms and water modifiers.

E.1.4 Verification Test Claims and Objectives

The overall objective of this ETV was to validate the performance of the Siemens Water Technologies H-4XE-HO (2W-1B-1C) open channel UV disinfection system at water quality (UVT) and dose (RED) conditions reflective of secondary effluent and reuse applications. The total attenuation factor of 80% was selected by Siemens as a combined effect of 90% sleeve fouling factor and 90% of end-of-lamp-life factor. This attenuation was mimicked by lowering the test water transmittance. Within this goal, specific objectives were fulfilled. Discussions and presentation of the results that meet these objectives are presented in this Executive Summary, and detailed in the Verification Report:

- 1) Verified the performance difference between power turndown and UVT turndown at the same operating conditions to mimic the total attenuation factor.
- 2) Verified the flow-dose relationship for the system at nominal UV transmittances of 50%, 65% and 80% for a dose range of 5 to 25 mJ/cm² using a biological surrogate with a relatively high sensitivity to UV (T1 coliphage).
- 3) Verified the flow-dose relationship for the system at a nominal UV transmittance of 50%, 65% and 80% for a dose range of 10 to 40 mJ/cm² using a biological surrogate with medium sensitivity to UV (Qβ coliphage).
- 4) Verified the flow-dose relationship for the system at a nominal UV transmittance of 50%, 65% and 80% for a dose range of 20 to 80mJ/cm² using a biological surrogate with relatively low sensitivity to UV (MS2 coliphage).
- 5) Adjusted the observed RED performance results by a validation factor in order to account for uncertainties associated with the verification tests.
- 6) Verified the power consumption of the unit.
- 7) Developed a dose-algorithm to control dose-delivery on a real-time basis, based on the systems primary operating variables.

E.2 VALIDATION TEST RESULTS

Biodosimetric tests were conducted at a simulated total attenuation factor of 80%, representing the combined effects of the end-of-lamp-life (EOLL) factor and the fouling factor. The total attenuation factor for the Siemens H-4XE-HO (2W-1B-1C) system was simulated by lowering the water transmittance. For the three nominal UVT values tested for this validation,

80%, 65%, and 50%, the actual UVT levels that were needed to include simulation of the 80% sensor attenuation were 74.5%, 60.4% and 45.8%, respectively.

E.2.1. Bidosimetric Assay Results

A total of 31 acceptable flow tests were conducted for this ETV. Three different coliphage were used as the challenge organisms: MS2, Q β and T1. The reported reduction equivalent dose (RED) is based upon the dose-response curve for the collimated beam data from the same day. The bidosimetric RED data are presented as a function of flow per lamp in Figure E-1 for each challenge phage at their respective nominal UVT levels. The bounds described by these data represent the validated operating envelope for the UV system:

Flow: 134 to 866 gpm

Flow/lamp 8.37 to 54.14 gpm/lamp

UVT: 50 to 80%

Power: 100 at PLC, or 100% input (2.75 kW/16 lamps, or 171 W/lamp)

E.2.2 Technical Test Results

E.2.2.1 Power Consumption

The power consumption of the Siemens H-4XE-HO (2W-1B-1C) system was continuously logged when operating. The mean total power input was 2.75 kW, or 171 W/lamp.

E.2.2.2 Headloss

Headloss estimates were derived from the hydraulic profile data. Two sample locations (immediately before and after the unit) were used at eight different flow rates. The influent depth was held constant by adjusting the downstream weir height. The headloss for the unit can be estimated from the expression:

$$\text{Headloss (in. of water)} = 3.160 (\text{flow, mgd})^2 - 0.938 (\text{flow, mgd}) + 0.148$$

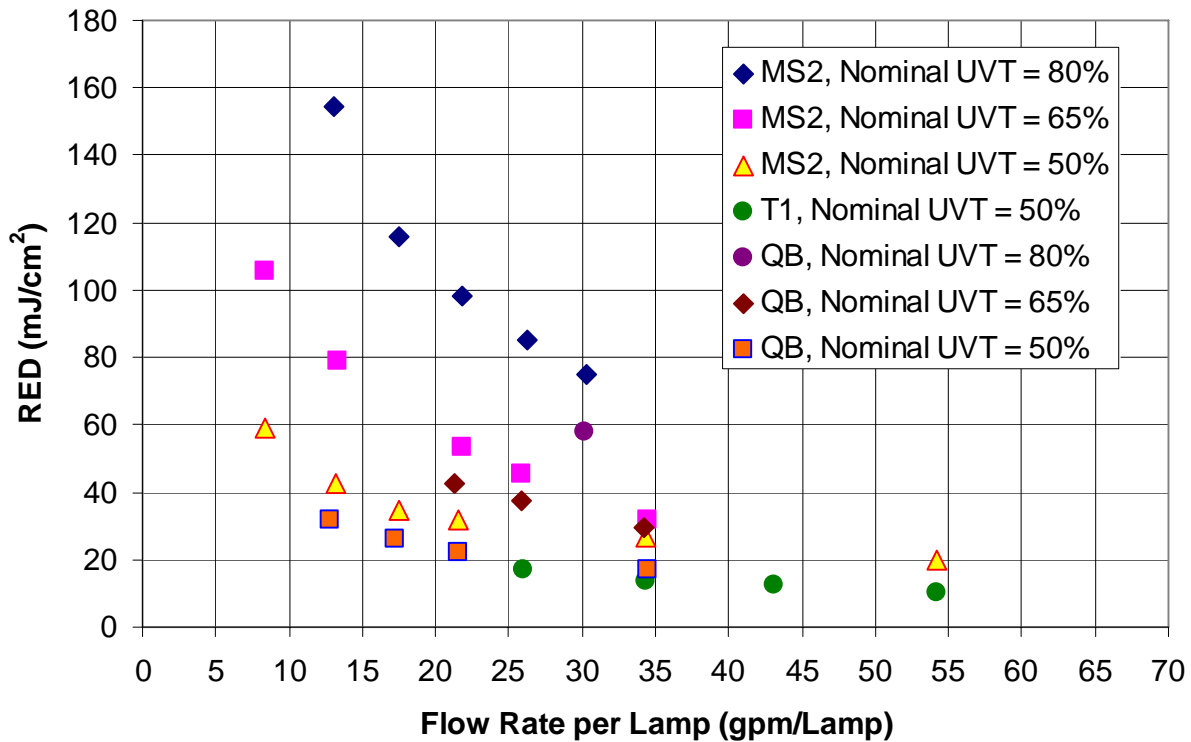

Figure E-1. MS2, T1 and QB RED as a function of UVT and Flow/Lamp.

E.2.2.3 Velocity Profiles

Cross-sectional velocity measurements were taken at 0.2 (138 gpm) and 0.8 mgd (561 gpm). This maximum is less than the maximum flow tested biosimetrically, and in some cases may establish the maximum flow rate/lamp. This will depend on guidance relevant to certain applications (such as in reuse, based on NWRI guidance). Per guidance in the NWRI/AWWARF Ultraviolet Disinfection Guidelines for Drinking Water and Water Reuse (2003), the mean velocity at any measured cross-sectional point of a commissioned system should not vary by more than 20% from the theoretical average velocity (i.e., flow divided by the cross-sectional area). Further, the commissioned system should exhibit velocity profiles that are equivalent or better than those exhibited by the validated test unit. This is particularly important if there is scale-up from the test unit.

The full record of velocity measurements is compiled in Appendix C. Overall, a general observation is that the velocity profiles were variable at 0.8 mgd. The effluent measurements tended to be outside the targeted range. The influent measurements at 0.8 mgd were fairly stable, less variable than the effluent. At 0.2 mgd, velocity profiles were more stable, although the influent was outside of the variability guideline at the surface. A key observation that can be

made from these data is that the hydraulic conditions represent a ‘worse’ case when compared to minimum full-scale commissioning requirements. As such, the biosimetry performance data can be considered conservative.

E.2.2.4 Sensor Model

When commissioned, it is necessary to assure that the same sensor position is maintained and the same readings are obtained at given operating conditions. To assist with this objective, sensor measurements were analyzed and a sensor model developed to allow prediction of the sensor reading in a commissioned system:

$$S = 0.000082645 (\text{UVT}_{254})^{3.169}$$

Where:

S = Sensor reading (%)

UVT₂₅₄ = UV transmittance at 254nm (%/cm)

Figure E-2 presents the model predictions as a function of the UVT. These data are at a power setting, P, of 100, which is the normal operating condition for the H-4XE-HO (2W-1B-1C). As shown, there is good agreement, providing a tool to assess the sensor position and function for a commissioned system.

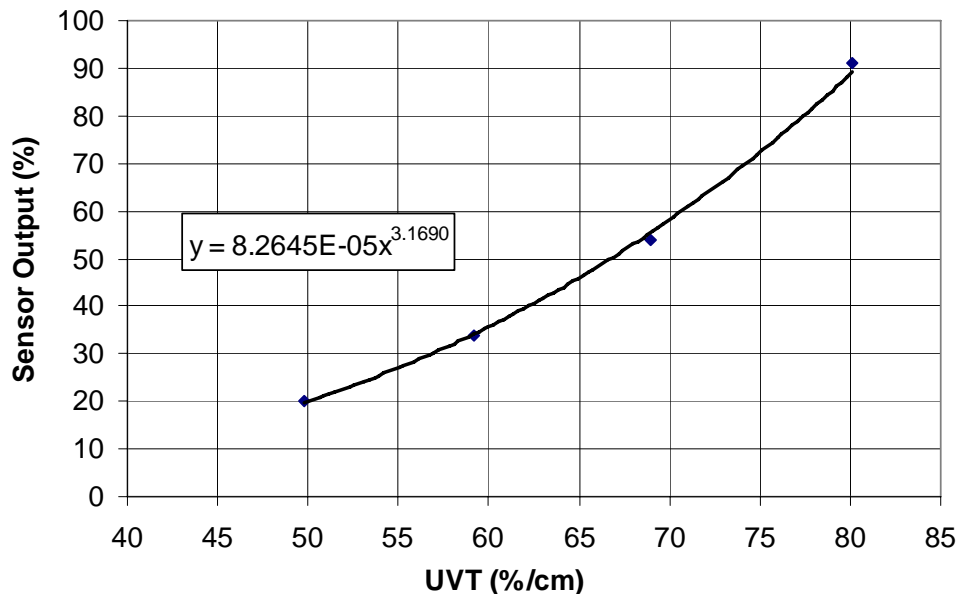

Figure E-2. Sensor model prediction as a function of UVT.

E.3 CREDITED DOSE-DELIVERY PERFORMANCE

E.3.1 RED Performance Algorithm

A dose algorithm was developed to correlate the observed MS2, T1 and Qβ RED data with the reactor's primary operating variables. These are the flow rate per lamp, Q/L, and sensor reading, S (a function of the lamp output and the UVT). These variables are known on a real-time basis by the PLC and can be programmed into software to monitor and control the UV system. Because multiple surrogates were used to test the system, the test results can be combined to incorporate the sensitivity of each to differentiate their individual reactions at the specified operating conditions. The commissioned system can then incorporate the sensitivity of the targeted pathogen (e.g., total or fecal coliform, enterococcus, etc.) when calculating the RED delivered by the system. The dose algorithm to estimate the RED is:

$$RED = 10^a \cdot (Q / L)^b \cdot S^c \cdot UVS^d$$

Where;

Q = Flow rate, gpm

L = Number of lamps

S = Sensor Reading (%)

UVS = UV Sensitivity (mJ/cm²/Log Inactivation)

a, b, c, d = Equation coefficients

The same sensors and their installed conditions, such as model type, position relative to the lamp, sleeve clarity, etc., must be used to apply this algorithm. Based on a multiple linear regression analysis in the form of this RED equation, the coefficients were determined and are summarized in Table E-1. The algorithm-calculated REDs versus the observed MS2, T1 and Qβ REDs are plotted in Figure E-3; good agreement is observed between the predicted and observed RED.

Table E-1. H-4XE-HO (2W-1B-1C) Dose-Algorithm Regression Constants

<u>Coefficient</u>	<u>Value</u>
a	0.950550
b	-0.609884
c	0.683241
d	0.398391

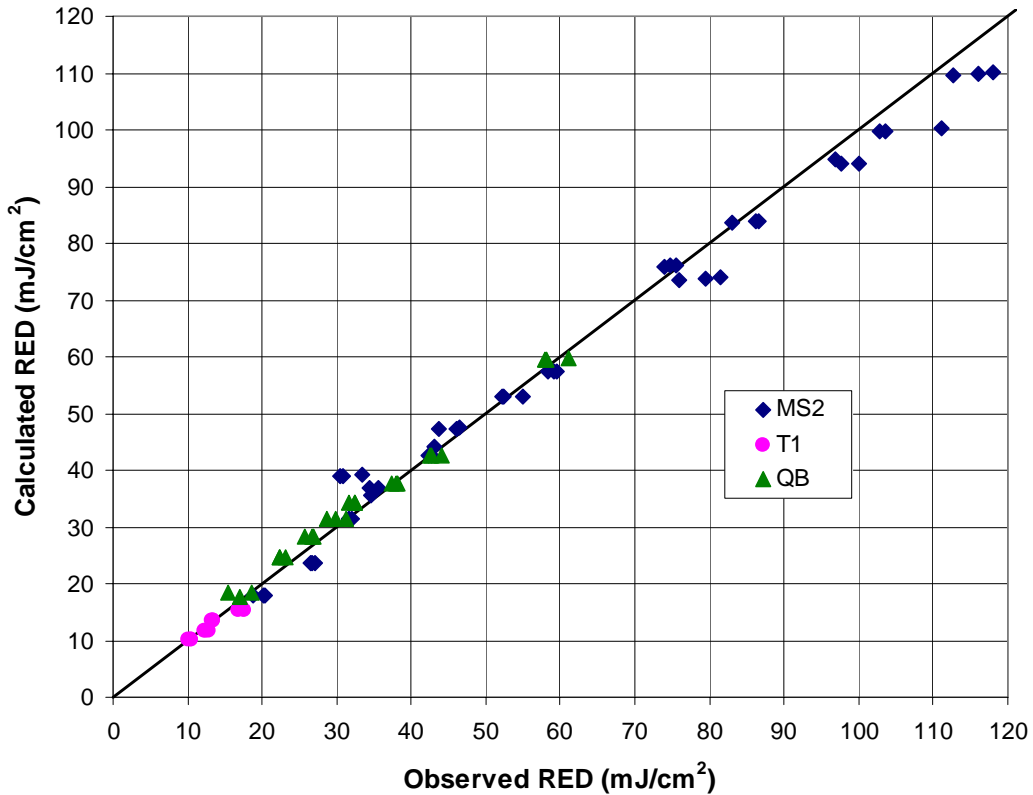

Figure E-3. Algorithm Calculated RED versus Observed RED.

E.3.2 Validation Factor

The VF components B_{RED} , B_{POLY} and U_{Val} were assessed. The RED bias, B_{RED} , can be set at 1.0 as long as the sensitivity of the targeted pathogen or pathogen indicator is within the range of 5 and 20 mJ/cm²/LI, and the sensitivity used in the RED algorithm is equal to or less than the sensitivity of the targeted microbe. B_{POLY} is set to 1.0 because the system uses low-pressure monochromatic lamps.

Within the uncertainty of validation, U_{Val} , the uncertainties associated with the sensors (U_S) and the collimated beam tests (U_{DR}) can be ignored because QA criteria were met, leaving only the uncertainty of interpolation, U_{IN} . With its specific elements assessed and defined, the validation factor for the Barrier Sunlight H-4XE-HO (2W-1B-1C) can be expressed as a function of the U_{IN} , which reduces to the following expression as a function of the calculated RED:

$$VF = 1 + (6.017/RED_{Calc})$$

Figure E-4 presents a series of solutions for VF at a UVT of 50% and sensitivities ranging between five and 20 mJ/cm²/LI. VF is shown as a function of flow/lamp under these specific and fixed operating conditions. Similar calculations can be made at alternate operating conditions. These calculations are appropriate only when the UVS of the targeted pathogen is equal to or greater than the sensitivity chosen for the calculations. Thus, if the sensitivity of the organism of concern is 10 mJ/cm²/LI, then UVS must be 10 or less when conducting the calculations for the VF. If this is not the case, then an RED bias term, similar to that described by the UVDGM, would have to be incorporated into the validation factor.

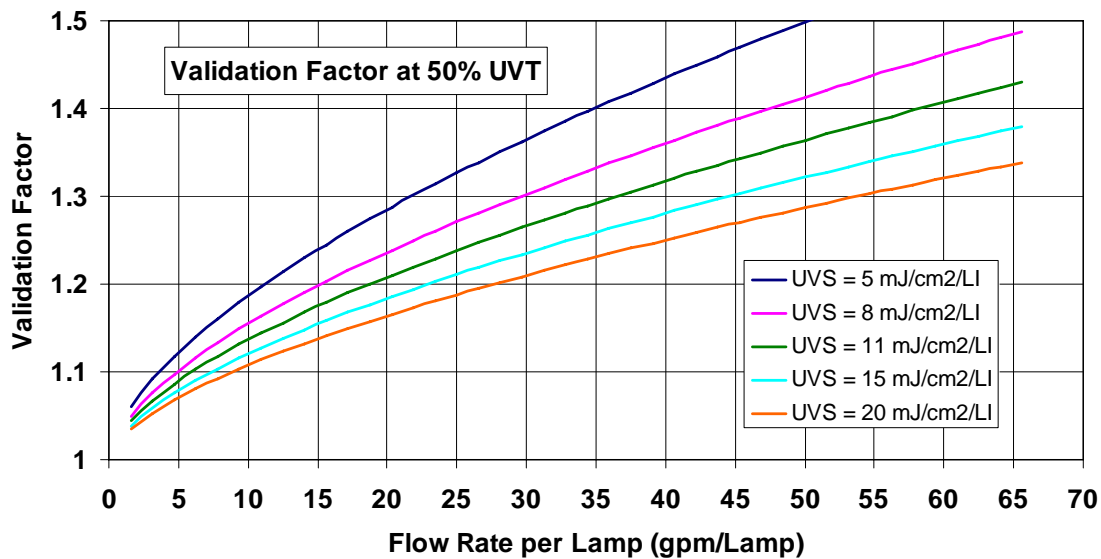

Figure E-4. Example solutions for Validation Factor at fixed operating conditions and a range of UV sensitivities.

E.3.3 Credited RED Calculation

Given the validation RED results and the estimate of uncertainty associated with the experimental effort, one can determine the RED that can be applied, or credited, to the system at prescribed operating conditions. This credited, or validated RED (RED_{val}), is calculated as:

$$RED_{val} = \frac{RED_{calc}}{VF}$$

Figure E-5 presents solutions for the H-4XE-HO (2W-1B-1C) at a UVT of 50%, across the same range of UV sensitivities. It is important to note that this assumes the system sensors have been confirmed to have the same output as in the validation. The solutions for validated, or credited, RED (RED_{val}), such as those shown on Figure E-5, would be reported at the PLC of the Barrier Sunlight H-4XE-HO (2W-1B-1C), based on monitored real-time operating conditions.

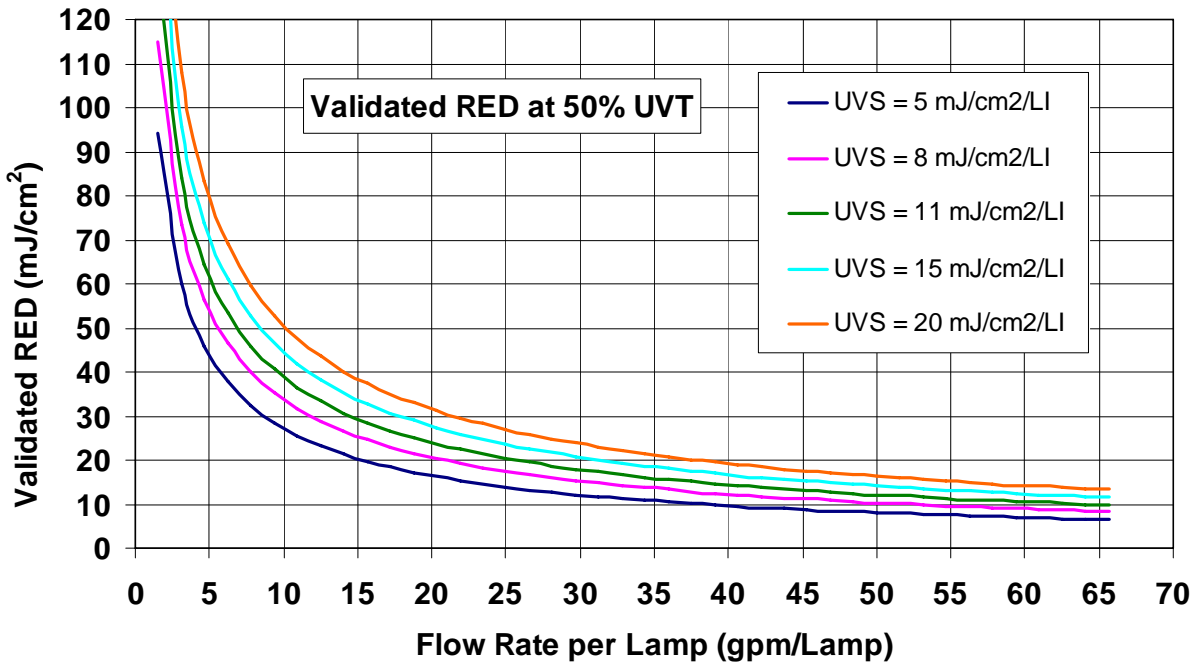

Figure E-5. Credited RED at 50% UVT Across a Range of UV Sensitivities

Table E-2 provides credited RED solutions across a broad range of operating conditions for the H-4XE-HO (2W-1B-1C) at sensitivities between 5 and 20 mJ/cm²/LI. Figure E-5 displayed those calculations pertinent to the 50% UVT conditions; similar graphical plots can be generated by the user at alternate conditions.

Table E-2. Credited RED Solutions

UVT (%T)	S (%)	Q/L (gpm/L)	Credited RED (mJ/cm ²) at UVS (mJ/cm ² /LI)				
			5	8	11	15	20
50	20.0	8.4	30.7	37.9	43.7	50.1	56.8
50	20.0	10.0	27.2	33.7	38.8	44.6	50.5
50	20.0	14.0	21.4	26.6	30.8	35.4	40.3
50	20.0	18.0	17.8	22.2	25.8	29.7	33.9
50	20.0	25.0	13.9	17.5	20.4	23.6	27.0
50	20.0	30.0	12.1	15.3	17.8	20.7	23.7
50	20.0	35.0	10.7	13.6	15.9	18.5	21.2
50	20.0	40.0	9.6	12.3	14.4	16.7	19.2
50	20.0	45.0	8.8	11.2	13.1	15.3	17.6
50	20.0	50.0	8.1	10.3	12.1	14.2	16.3
50	20.0	54.0	7.6	9.7	11.4	13.3	15.4
55	27.1	8.4	38.8	47.7	54.8	62.7	71.0
55	27.1	10.0	34.4	42.4	48.8	55.9	63.3
55	27.1	14.0	27.2	33.7	38.9	44.6	50.6
55	27.1	18.0	22.7	28.3	32.7	37.6	42.7
55	27.1	25.0	17.9	22.4	26.0	30.0	34.1
55	27.1	30.0	15.6	19.6	22.8	26.3	30.1
55	27.1	35.0	13.9	17.5	20.4	23.6	27.0
55	27.1	40.0	12.6	15.9	18.5	21.4	24.5
55	27.1	45.0	11.5	14.5	17.0	19.7	22.6
55	27.1	50.0	10.6	13.4	15.7	18.2	20.9
55	27.1	54.0	9.9	12.6	14.8	17.2	19.8
60	35.7	8.4	47.8	58.6	67.3	76.8	86.8
60	35.7	10.0	42.5	52.2	60.0	68.5	77.5
60	35.7	14.0	33.7	41.6	47.9	54.9	62.1
60	35.7	18.0	28.3	35.1	40.4	46.4	52.6
60	35.7	25.0	22.4	27.9	32.3	37.1	42.2
60	35.7	30.0	19.6	24.5	28.4	32.7	37.2
60	35.7	35.0	17.5	21.9	25.5	29.4	33.5
60	35.7	40.0	15.9	19.9	23.2	26.7	30.5
60	35.7	45.0	14.5	18.3	21.3	24.6	28.1
60	35.7	50.0	13.4	16.9	19.7	22.8	26.1
60	35.7	54.0	12.6	16.0	18.6	21.6	24.7
65	46.0	8.4	57.8	70.7	81.0	92.3	104.2
65	46.0	10.0	51.4	63.1	72.3	82.5	93.1
65	46.0	14.0	41.0	50.4	57.9	66.2	74.9
65	46.0	18.0	34.5	42.6	49.0	56.1	63.5
65	46.0	25.0	27.4	34.0	39.2	45.0	51.1
65	46.0	30.0	24.1	30.0	34.6	39.8	45.2
65	46.0	35.0	21.6	26.9	31.1	35.8	40.7
65	46.0	40.0	19.6	24.5	28.3	32.6	37.2
65	46.0	45.0	18.0	22.5	26.1	30.1	34.3
65	46.0	50.0	16.6	20.8	24.2	27.9	31.8
65	46.0	54.0	15.7	19.7	22.9	26.4	30.2

Table E-2. Credited RED Solutions (Continued)

UVT (%T)	S (%)	Q/L (gpm/L)	Credited RED (mJ/cm ²) at UVS (mJ/cm ² /LI)				
			5	8	11	15	20
70	58.1	8.4	68.7	83.9	96.0	109.3	123.3
70	58.1	10	61.3	74.9	85.8	97.8	110.3
70	58.1	14	49.0	60.1	68.9	78.6	88.8
70	58.1	18	41.3	50.8	58.4	66.7	75.5
70	58.1	25	33.0	40.7	46.9	53.7	60.8
70	58.1	30	29.1	36.0	41.4	47.5	53.9
70	58.1	35	26.1	32.3	37.3	42.8	48.6
70	58.1	40	23.7	29.4	34.0	39.1	44.4
70	58.1	45	21.8	27.1	31.4	36.1	41.0
70	58.1	50	20.2	25.2	29.1	33.6	38.2
70	58.1	54	19.1	23.8	27.6	31.8	36.2
75	72.3	8.4	80.6	98.3	112.3	127.8	144.0
75	72.3	10	71.9	87.8	100.4	114.4	128.9
75	72.3	14	57.7	70.6	80.8	92.2	104.0
75	72.3	18	48.8	59.8	68.6	78.3	88.5
75	72.3	25	39.0	48.1	55.2	63.2	71.4
75	72.3	30	34.4	42.5	48.9	56.0	63.4
75	72.3	35	31.0	38.3	44.1	50.5	57.2
75	72.3	40	28.2	34.9	40.3	46.2	52.4
75	72.3	45	25.9	32.2	37.1	42.6	48.4
75	72.3	50	24.1	29.9	34.5	39.7	45.1
75	72.3	54	22.8	28.3	32.8	37.7	42.8
80	88.7	8.4	93.5	113.9	130.0	147.8	166.5
80	88.7	10	83.5	101.8	116.3	132.3	149.1
80	88.7	14	67.1	81.9	93.7	106.8	120.4
80	88.7	18	56.8	69.6	79.7	90.8	102.5
80	88.7	25	45.6	56.0	64.3	73.4	82.9
80	88.7	30	40.3	49.6	57.0	65.1	73.7
80	88.7	35	36.3	44.7	51.4	58.8	66.6
80	88.7	40	33.1	40.8	47.0	53.8	61.0
80	88.7	45	30.5	37.7	43.4	49.8	56.4
80	88.7	50	28.3	35.1	40.4	46.4	52.6
80	88.7	54	26.8	33.2	38.4	44.0	50.0

E.4 EXAMPLE CALCULATIONS FOR SIZING THE SIEMENS H-4XE-HO (2W-1B-1C)

An example is given to illustrate the calculations that can be conducted to evaluate the sizing of the Siemens H-4XE-HO (2W-1B-1C). Consider the following design condition:

Flow Rate: 6000 gpm (8.64 mgd)

UVT: 55%

Performance Requirement with two reactors in series:

Application 1: Secondary Effluent, Fecal Coliform < 200 cfu/100 mL (2.3 Log)

Application 2: Reuse, MS2 Dose > 80 mJ/cm²

E.4.1 Application 1

This is a “low-dose” application, directed at typical secondary effluents discharged from wastewater treatment plants. In such cases, collimated-beam measurements would be made to develop a dose-response (DR) relationship, based on fecal coliform. An example of such data is provided in Figure E-6, showing the tailing effect due to particulates. Taking the non-aggregated, linear portion of the curve, the UV sensitivity is estimated to be 6.9 mJ/cm²/LI. From the DR data, one can observe that the maximum effective dose is in the vicinity of 25 mJ/cm², beyond which the particulate coliform control and little apparent disinfection occurs. In order to meet the specification, a lower (than the permit maximum) target fecal coliform is considered; and the dose is set at 25 mJ/cm².

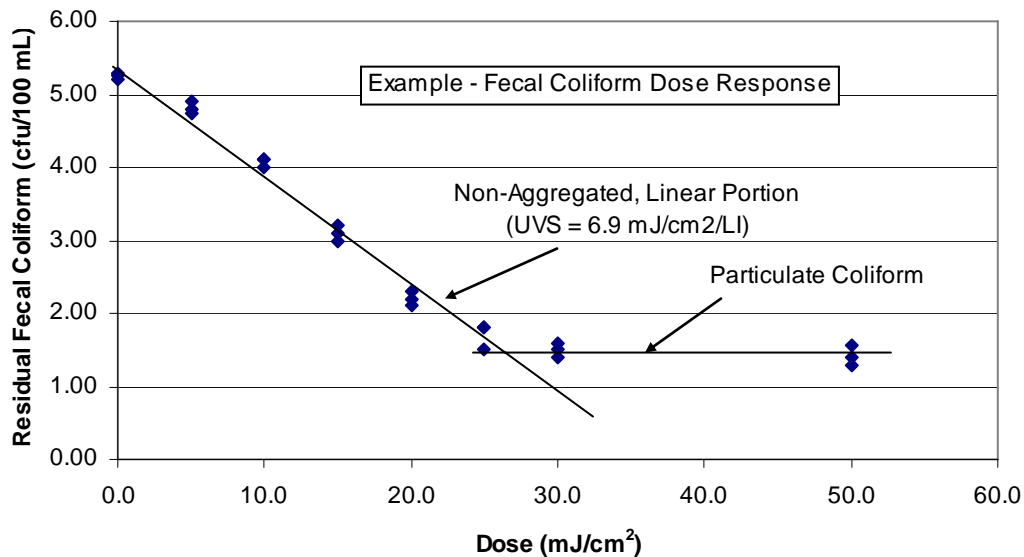

Figure E-6. Example Fecal Coliform Dose-Response curve.

As noted, sizing should consider having two reactors in series to meet this targeted dose. Since dose is additive, each reactor would need to deliver at least 12.5 mJ/cm² at the design flow and UVT. Using the dose algorithm, compute the RED_{calc} as a function of flow/lamp. S is determined at 27.07 (Table E-2), reflecting the same placement of the sensor as in the validation

unit. The UVS in this case is $6.9 \text{ mJ/cm}^2/\text{LI}$, as shown on Figure E-6 for the site-specific fecal coliform. The flow/lamp input can be varied to evaluate RED_{calc} as a function of hydraulic loading.

Figure E-7 presents solutions for RED_{calc} as a function of flow/lamp. These must then be adjusted for the Validation Factor (VF), yielding the validated, or credited, RED. Solutions for validated RED are also shown on Figure E-7. As shown, a hydraulic loading equal to or less than 49.7 gpm/lamp will yield an RED of at least 12.5 mJ/cm^2 in a single reactor; two would be placed in series for a credited RED of 25 mJ/cm^2 . At the design flow of 6000 gpm , each bank would require $6000/49.7 = 120$ lamps. Note that this analysis is simplified as an example, and does not address redundancy or other design considerations.

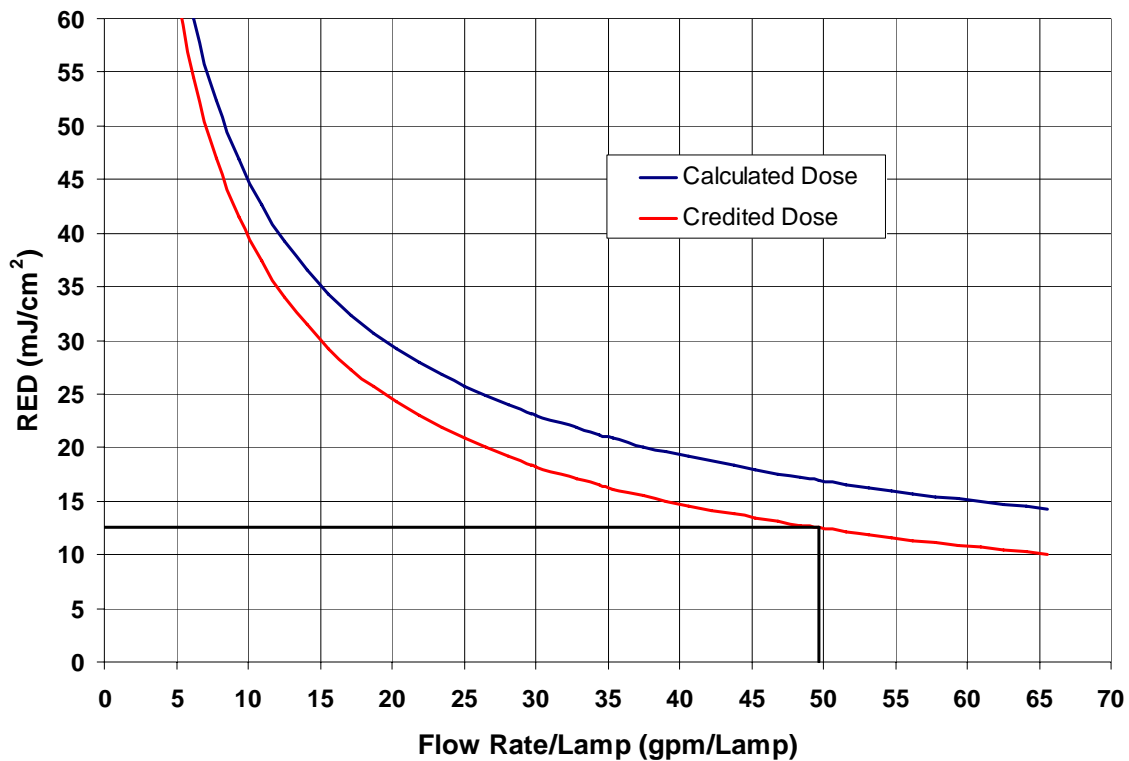

Figure E-7. Example calculation of RED as a function of flow (55% UVT) for an H-4XE-HO (2W-1B-1C) reactor in a low-dose application.

E.4.2 Application 2

In the second application, the performance requirement is to meet an MS2 RED of 80 mJ/cm^2 , a criterion typically found with reuse applications after membrane-filtered secondary treatment. The approach is the same as discussed above for the “low-dose” application, except that an MS2 UV sensitivity value is used. This is $20 \text{ mJ/cm}^2/\text{LI}$. Solutions for calculated and

credited RED are provided in Figure E-8. In this case, two reactors are placed in series, with a hydraulic loading of 19.85 gpm/lamp. To meet the design flow of 6000 gpm, approximately 303 lamps are needed for each reactor. This would likely be divided to 2 or three parallel channels. Note that this is provided as a simplified example; other design aspects such as redundancy are not considered.

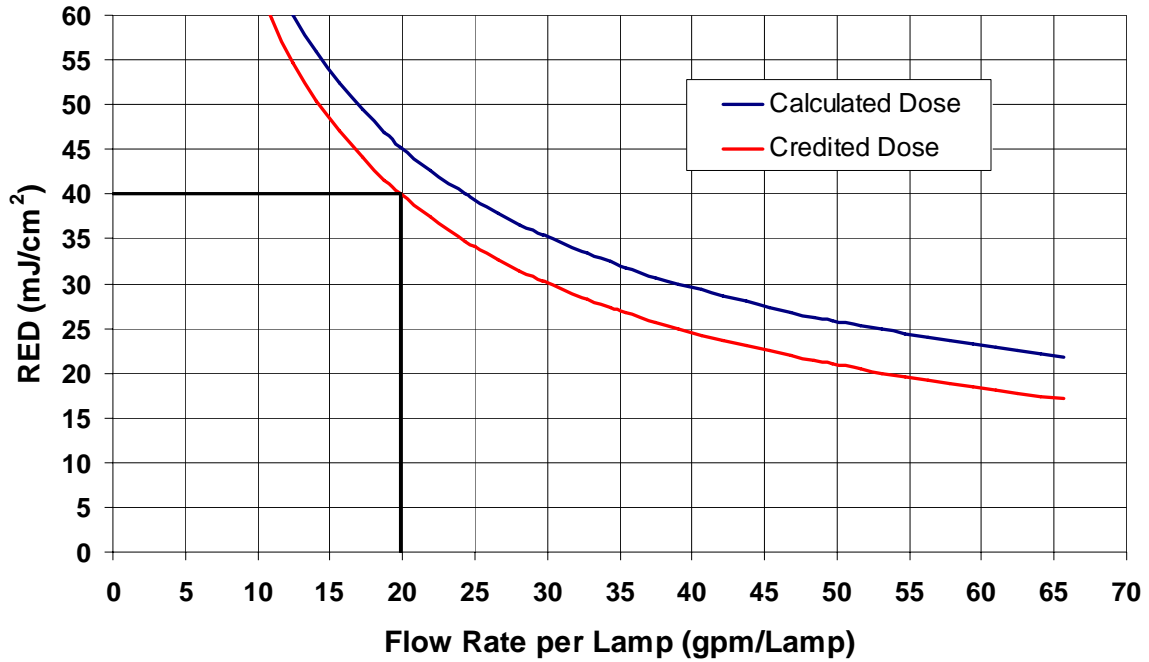

Figure E-8. Example calculation of RED as a function of flow (55% UVT) for a H-4XE-HO (2W-1B-1C) reactor in a reuse application.

SECTION 1

INTRODUCTION AND BACKGROUND

1.1 THE ETV PROGRAM

1.1.1 Concept of the ETV Program

The Environmental Technology Verification (ETV) program was created to accelerate the development and commercialization of environmental technologies through third party verification and reporting of performance. The goal of the ETV program is to verify performance characteristics of commercial-ready environmental technologies through the evaluation of objective and quality assured data so that potential buyers and regulators are provided with an independent and credible assessment of the technology that they are buying or permitting.

1.1.2 The ETV Program for Water Reuse and Secondary Effluent Disinfection

This report documents the testing, data reduction and analysis in conformance with the recently developed test protocol, “Validation of UV Reactors for Application to the Disinfection of Treated Wastewaters” (2008, hereafter, referred to as the WW Protocol), which combines and updates the objectives and methods found in established UV disinfection guidance documents. The “Ultraviolet Disinfection Guidelines for Drinking Water and Water Reuse” by the National Water Research Institute and the American Water Works Association Research Foundation (NWRI/AwwaRF) (2003) was used as an important guidance for this validation report. The United States Environmental Protection Agency (USEPA) “UV Disinfection Guidance Manual” (UVDGM, November 2006), and the “Verification Protocol for Secondary Effluent and Water Reuse Disinfection Applications” by NSF International and the USEPA under the Environmental Technology Verification Program (ETV, 2000) were also important references.

The WW Protocol provides general guidance on the validation of the performance of commercial UV systems, but is not application-specific, such as for reuse, secondary effluent, or wet weather flows, as categorized in previously used verification protocols. Instead, a vendor chooses to conduct validations covering a range of operating conditions (i.e., operating “envelope”) and dose levels to meet their marketing expectations regarding the application of their respective UV systems.

1.1.3 The Siemens Water Technologies ETV

This ETV of the Siemens Water Technologies H-4XE-HO (2W-1B-1C) UV disinfection unit focused on dose-delivery verification at water UV transmittances between 50% and 80%. The total intensity attenuation factor was 80%, as set by Siemens based on the combined effects of a sleeve-fouling factor of 90% and lamp aging-factor (end-of-lamp-life factor, or EOLL) of 90%. The unit was operated at full power input under all conditions, and the flow ranged between 134 and 866 gpm. Biosimetric testing was accomplished with three test organisms: coliphages MS2, T1 and QB.

1.2 MECHANISM OF UV DISINFECTION

Ultraviolet (UV) light radiation is a widely accepted method for accomplishing disinfection of treated wastewaters. Its germicidal action is attributed to its ability to photochemically damage links in the DNA molecules of a cell, which prevents the future replication of the cell, effectively “inactivating” the microorganism. UV radiation is most effective in the region of the electromagnetic spectrum between 230 and 290 nm (referred to as the UVC range); this corresponds to the UV absorbance spectrum of nucleic acids. The optimum germicidal wavelengths are in the range of 255 to 265 nm.

1.2.1 Practical Application of UV Disinfection

The dominant commercial source of UV light for germicidal applications is the mercury vapor, electric discharge lamp. These are commercially available in “low-pressure” and “medium-pressure” configurations. The conventional low-pressure lamp operates at 0.007 mm Hg, and is typically supplied in long lengths (0.75 to 1.5 m), with diameters between 1.5 and 2 cm. The major advantages of the low-pressure lamp are that its UV output is essentially monochromatic at a wavelength of 254 nm, and it is energy efficient, converting approximately 35 to 38 percent of its input energy to UV light at the 254 nm wavelength. The UV power output of a conventional low-pressure lamp is relatively low, typically about 25 W at 254 nm for a 70 to 75 W, 1.47-m long lamp. Low-pressure, high-output (LPHO) lamps (~0.76 mm of Hg) have also been developed using mercury in the form of an amalgam and/or higher current discharges. LPHO lamps are very similar in appearance to the conventional low-pressure lamps, but have power outputs 1.5 to five times higher, reducing the required number of lamps for a given application. LPHO lamps have approximately the same efficiency of conventional low-pressure lamps.

Medium-pressure lamps operate between 300 to 30,000 mm of Hg, and can have many times the total UVC output of a low-pressure lamp. Such medium-pressure lamps emit

polychromatic light, and convert between 10 to 20 percent of the input energy to germicidal UV radiation, resulting in lower efficiency. However, the sum of all the spectral lines in the UVC region for a medium-pressure lamp results in three to four times the germicidal output when compared to low-pressure lamps. Because of the very high UV output rates, fewer medium-pressure lamps are needed for a given application when compared to low-pressure lamps.

Both low- and medium-pressure germicidal lamps are sheathed in quartz sleeves, configured in geometric arrays, and placed directly in the wastewater stream. The lamp systems are typically modular in design, oriented horizontally or vertically, mounted parallel or perpendicular to flow, and assembled in single or multiple channels and/or reactors.

The key design consideration is directed to efficient delivery of the germicidal UV energy to the wastewater and to the organisms. The total germicidal effectiveness is quantified as the “UV dose,” or the product of the UV radiation intensity (I , Watts/cm²) and the exposure time (t , seconds) experienced by a population of organisms. The effective intensity of the radiation is a function of the lamp output, and of the factors that attenuate the energy as it is deposited into the water. Such attenuating factors include simple geometric dispersion of the energy as it moves away from the source, absorbance of the energy by the quartz sleeve housing the lamp, and the UV absorbance, or UV demand, of the energy by constituents in the wastewater.

1.2.2 A Comparison of UV and Chemical Disinfection

UV disinfection uses electromagnetic energy as the germicidal agent, differing considerably from chemical disinfection agents such as chlorine or ozone. The lethal effect of UV radiation is manifested by the organism’s inability to replicate, whereas chemical disinfection physically destroys the integrity of the organism via oxidation processes. Germicidal UV radiation does not produce significant residuals, whereas chemical disinfection results in residuals that may exist long after the required disinfection is complete. Chemical residuals, such as chlorine or chloramines, may then have a detrimental effect on organisms in the natural water system to which the effluent is released. An additional, subsequent process, such as dechlorination, usually ameliorates this detrimental result. This residual effect does not exist for UV disinfection processes.

Chemical disinfection involves shipping, handling, and storing potentially dangerous chemicals. In contrast, dangers associated with UV disinfection are minimal. A UV disinfection system produces high-intensity UVC radiation, which can cause eye damage and skin burns upon exposure; however, these dangers are easily prevented with protective clothing and goggles, and by properly enclosing or shielding the UV system. A minor hazard exists because the lamps

contain very small amounts of liquid or amalgamated mercury requiring that lamps be disposed of properly. The primary cost associated with operating UV disinfection systems is the continuous use of significant amounts of electrical power, and routine maintenance, whereas chemical generation and use is the primary operating expense for chemical disinfection systems.

1.2.3 Determining Dose Delivery

In theory, the delivery of UV radiation to a wastewater can be computed mathematically if the geometry and hydraulic behavior of the system are well characterized. Ideally, all elements entering the reactor should be exposed to all levels of radiation for the same amount of time, a condition described as turbulent, ideal plug flow. In fact, non-ideal conditions exist; there is a distribution of residence times in the reactor due to advective dispersion and to mixing in the reactor. The degree to which the reactor strays from ideal plug flow will directly impact the efficiency of dose delivery in the system. Similarly, the intensity field in the reactor is variable, a function of the lamp output and spacing, and the UV absorbance of the liquid. Together, these aspects of UV reactor behavior dictate that some particles (microorganisms) will receive small UV doses, while other particles will receive larger doses. More generally, it can be asserted that all UV reactors that are used for water and wastewater treatment in practical applications are characterized by a UV dose distribution for any given operating condition.

Accurate predictions of UV reactor performance can be developed by integrating the UV dose distribution with the intrinsic kinetics of the reaction(s) of interest (*aka*, UV dose-response behavior). However, the validity of any such prediction relies on the validity of the dose distribution estimate, as well as the validity of the dose-response information. Purely numerical simulations were a natural evolution of this modeling approach. These simulations involve combined applications of computational fluid dynamics (CFD) with intensity field (I) models. Indeed, CFD-I models have evolved to the point where, in some cases, they now form the basis for design of new reactors. Manufacturers of UV systems have found that numerical prototyping is less expensive than physical prototyping, particularly as a means of optimizing reactor performance for a given application.

While numerical models, such as CFD-I, represent important tools for analysis of UV reactors, they have not evolved to the point where they can be used for reactor validation. Several issues can be identified that prevent the application of CFD-I models for validation: there is no uniform standard for their application; one can expect considerable uncertainty in the values of some important input variables (*e.g.*, lamp output power); and the models themselves may ignore or incompletely account for some relevant physical behavior (*e.g.*, reflection and

refraction of UV radiation). Collectively, these and other factors mean that CFD-I models are developing, but still need a basis for verification.

Lagrangian actinometry (LA) using dyed microspheres was developed as a method for direct measurement of the UV dose distribution delivered by a UV reactor for a given set of operating conditions. Microspheres coated with a photosensitive dye are pass through a reactor, with each particle fluorescing in proportion to the dose received in its individual trajectory. In other words, the method allows for dose measurement at the level of an individual particle. This is an emerging tool that will likely be available for direct validation of a reactor's log inactivation performance for any pathogen of known dose-response behavior.

1.2.4 Summary of the Biodosimetric Method to Measure Dose

Current practice uses biodosimetric techniques to assess the dose-delivery performance of UV reactors, whereby the inactivation of a surrogate challenge organism through a reactor is measured and compared to its dose-response behavior. This results in an estimate of the reduction equivalent dose (RED) delivered by the UV reactor. The UVDGM presents these biodosimetric techniques as current state-of-the-art, but recognizes the uncertainties associated with the selection and analysis of microbiological surrogates, and the potential for widely divergent dose-distribution characteristics. In order to mitigate the potential impact of such uncertainties, significant adjustments relating to these uncertainties are made to the observed RED before a credited inactivation is awarded to a specific reactor installation.

Biodosimetry is a method for determining the germicidal dose delivery to a wastewater by using an actual calibrated test organism. Put simply, the survival ratio of the organism is calibrated to a well-controlled UV dose in the laboratory with a dose-response procedure. The same organisms are then used to field test the actual disinfection system under specified conditions. Such field tests generate a survival ratio of the organism under specified test conditions, which can then be converted into an effective delivered dose through the dose-response calibration curve. This is termed the reduction equivalent dose, or RED, with units of mJ/cm^2 . For the tests in this ETV, the bacteriophages MS2, T1, and Q β were used.

The advantages to the biodosimetric method are that the organism records the actual germicidal dose, the organism can be produced in such large quantities that every milliliter of test solution contains a statistically significant number of organisms, and there are no assumptions about the hydraulic behavior or intensity field of the reactor. It is important to remember that this method is not used to determine the effective germicidal UV dose for any specific pathogen, it is a method to quantify germicidal dose delivery for a specific microbe.

SECTION 2

ROLES AND RESPONSIBILITIES OF PARTICIPANTS IN THE VERIFICATION TESTING

2.1 NSF INTERNATIONAL (NSF)

The Project Organization Chart is provided in Figure 2-1. The ETV Water Quality Protection Center (WQPC) is administered through a cooperative agreement between the USEPA and NSF International (NSF). NSF administers the program through the WQPC and selected a qualified Field Testing Organization (FTO). HydroQual, Inc. (HydroQual) developed and implemented the Verification Test Plan (VTP) for this ETV. NSF's project responsibilities included review and approval of the VTP, QA oversight, peer reviews, report approval and preparation and dissemination of the verification statement.

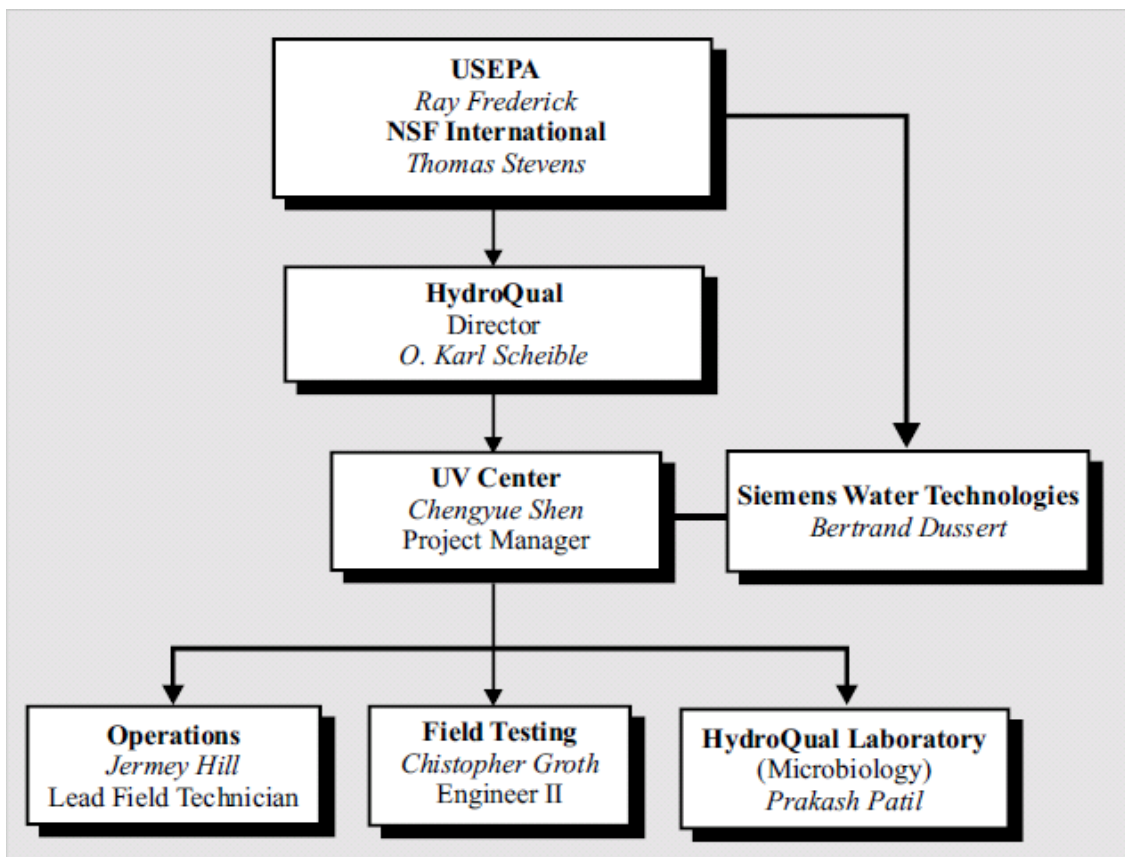

Figure 2-1. Project organization chart.

The key contact at NSF relating to this report is:

Mr. Thomas Stevens, Center Manager
NSF International
789 Dixboro Road
Ann Arbor, MI 48113
(734) 769-5347
stevenst@nsf.org

2.2 U.S. ENVIRONMENTAL PROTECTION AGENCY (USEPA)

The USEPA's National Risk Management Research Laboratory provides administrative, technical and quality assurance guidance and oversight on all WQPC activities. The USEPA has review and approval responsibilities through various phases of the verification project. The key USEPA contact is:

Mr. Ray Frederick
USEPA – NRML Urban Watershed Management Branch
2890 Woodbridge Avenue (MS-104)
Edison, NJ 08837-3679
(732) 321-6627
(732) 321-6640 (fax)
Frederick.ray@epa.gov

2.3 FIELD TESTING ORGANIZATION (FTO), HYDROQUAL, INC.

The selected FTO was HydroQual, Inc, which has a well-established expertise in the area of ultraviolet disinfection technologies. Mr. O. Karl Scheible, Project Director, provided overall technical guidance for the verification test program. Dr. Chengyue Shen, PE served as the Project Manager, responsible for day-to-day operations and technical analysis. Dr. Prakash Patil was the project microbiologist, responsible for all bacteriophage stock preparation and sample analyses, including collimated beam testing. HydroQual also provided additional in-house staff as required. HydroQual's responsibilities included development of the VTP, management of the testing effort, compilation and analysis of the data, and preparation of the verification report. HydroQual's main office is located in Mahwah, New Jersey and has a staff of over 110. The mailing address is:

HydroQual, Inc.
1200 MacArthur Blvd
Mahwah, New Jersey 07430
(201) 529-5151

(201) 529-5728 (fax)

<http://www.hydroqual.com>

Dr. Shen was the primary technical contact person at HydroQual:

Telephone extension: 7191, or

Cell phone: (201) 538-6820, or

Email: cshen@hydroqual.com

Mr. Scheible can be reached at extension 7178 or

Email: kscheible@hydroqual.com

2.4 VALIDATION TEST FACILITY

The ETV tests were conducted at the UV Validation and Research Center of New York (UV Center), Johnstown, NY, which is operated exclusively by HydroQual. The UV Center was installed at the wastewater treatment plant site with the support of the New York State Energy Research and Development Authority (NYSERDA), with direct participation by a number of manufacturers, including Siemens Water Technologies Corp. Active testing at the validation facility has been underway since June 2003. The UV Center address is:

HydroQual, Inc.

c/o Gloversville-Johnstown Joint Wastewater Treatment Facility

191 Union Ave Extension

Johnstown, New York 12095

HydroQual On-Site Contact: William Pearson, (646) 235-0382

Figure 2-2 is an aerial view of the Gloversville-Johnstown Joint Wastewater Treatment Facility. The location of the Test Facility within the plant is circled. Figure 2-3 shows an aerial view of the tanks and pumps at the UV Center. Up to eight 5500-gpm diesel-powered centrifugal pumps are available to feed the test systems. The accumulated effluent is slowly pumped (at rates up to 1500 gpm) back into the wastewater treatment plant for final disposal. Filtered, high-quality potable water from a surface water supply (90 to 97% UVT at 254 nm) is provided via a local hydrant. The water is dechlorinated with sodium sulfite. In cases when higher transmittance waters are needed, the UV Center has granular activated carbon (GAC) units to polish (and dechlorinate) the water. The UV Center also has access to treated secondary effluent, which is filtered through 20-micron cloth cartridge filters when filling the source water tanks.

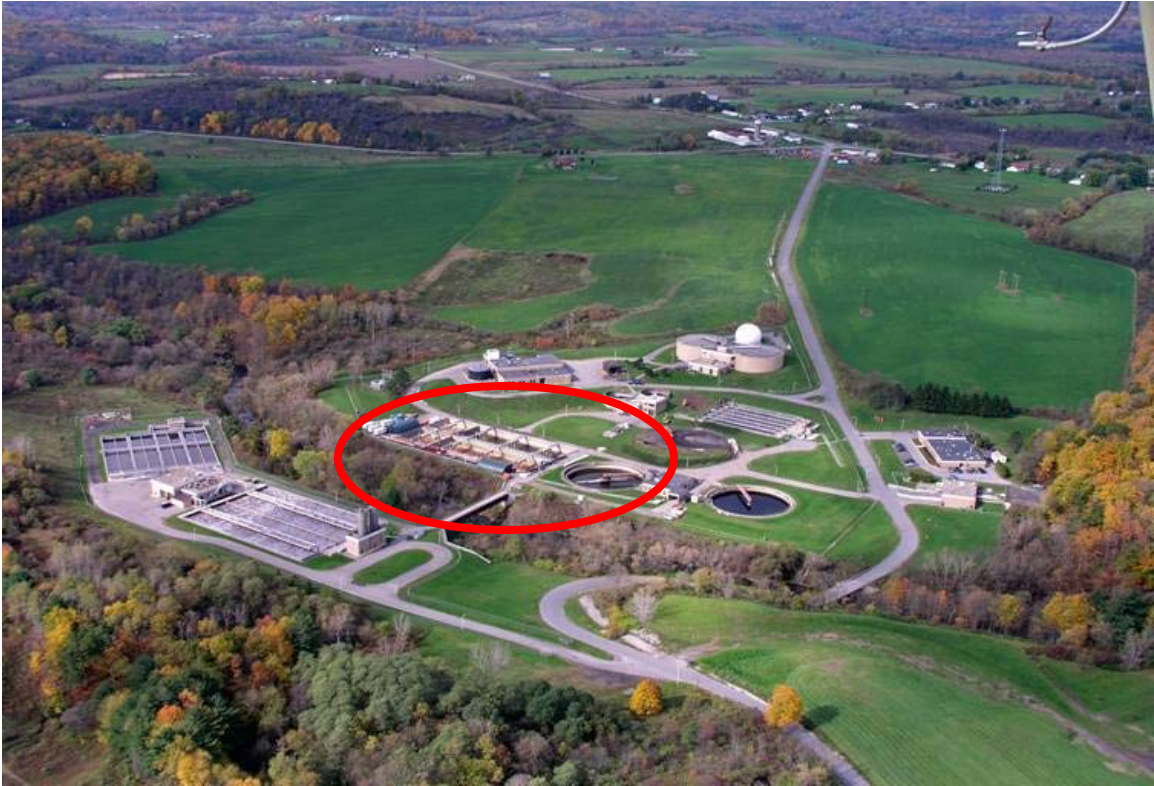

Figure 2-2. Aerial view of the Gloversville-Johnstown Joint Wastewater Treatment Facility and the UV Center.

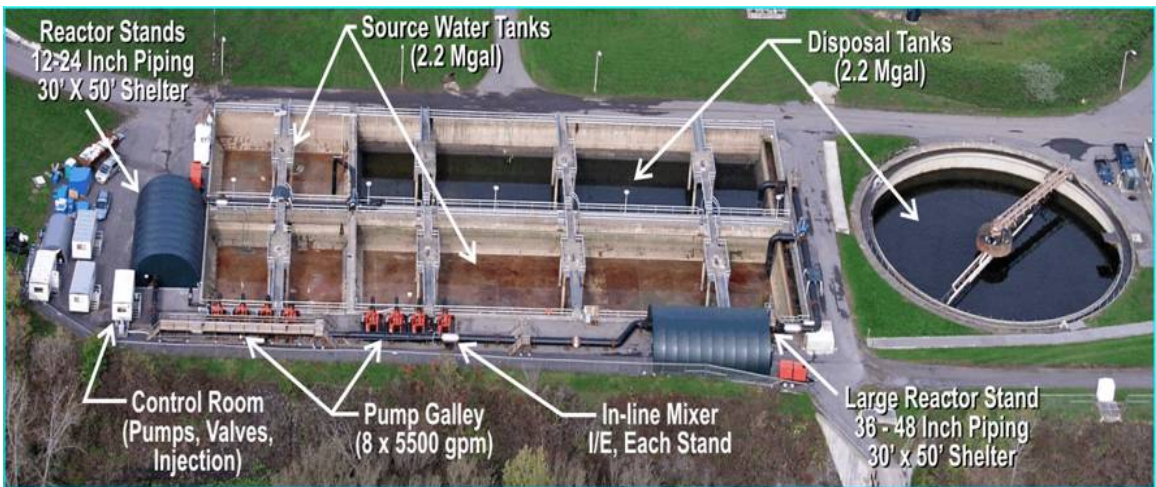

Figure 2-3. Aerial view of the UV Center tanks.

Figure 2-4 is a general schematic of the test facility. A number of test stands are available within the facility, ranging from 2-in. to 48-in. diameter feed piping. Typically, test stands are assembled from these piping systems to accommodate the reactor and preferred inlet/outlet piping configurations. Flow rate capacities range from five to 45000 gpm. The facility employs several large concrete tanks that are used to prepare source water for challenge testing, or to accept testing effluent. The general placement of the two Siemens test units is shown in Figure 2-4.

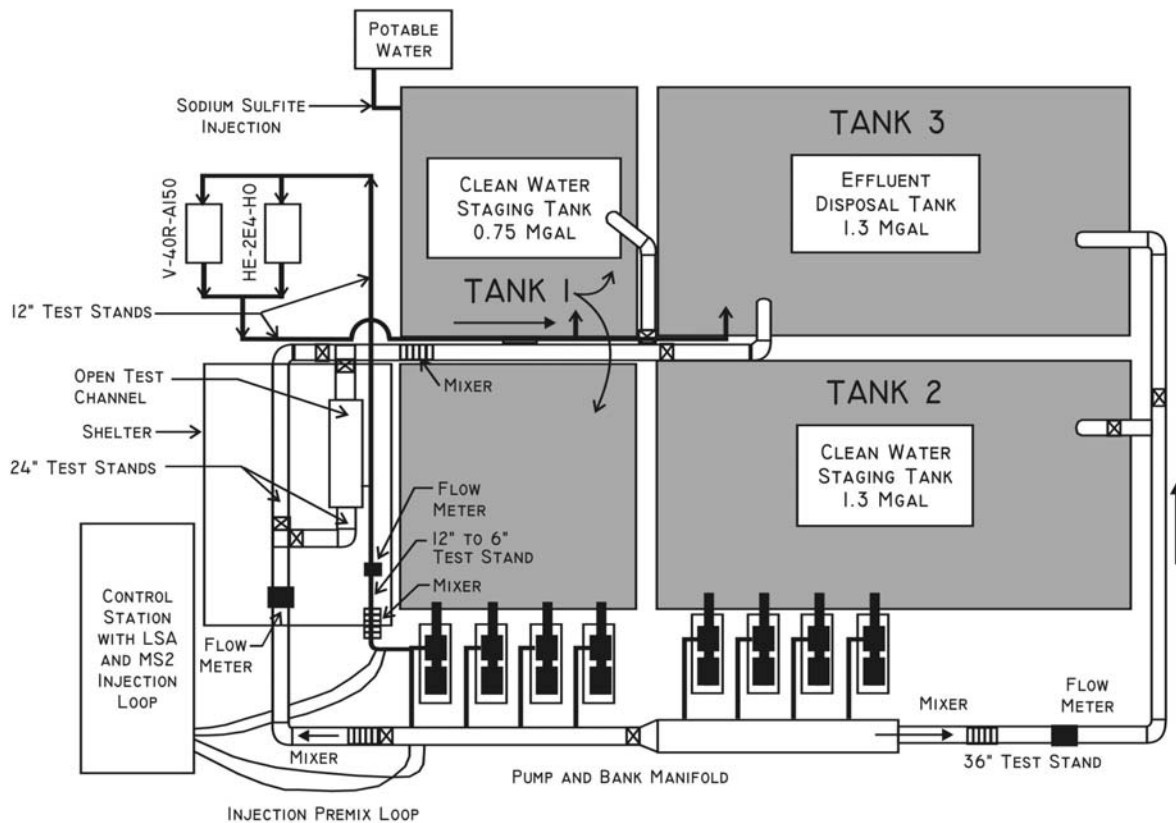

Figure 2-4. General schematic of the UV Test Facility showing major test stands (Tank 4 not shown).

A laboratory-grade GenTech Model 1901 Double Beam UV/Vis spectrophotometer is located at the UV Center. In addition, the UV Center provides for pH, turbidity, total chlorine, and temperature measurements. A diesel-fired generator is used on-site exclusively to power the UV test units. This allows power conditioning specific to the targeted unit. Other, low-power electrical requirements are tapped off a local service. Power logging on the input to the UV unit

power panel is always practiced. Multi-channel data-logging capabilities are available and are used as needed to record relevant electrical signals, such as flow meter and intensity sensor outputs.

2.5 UV TECHNOLOGY VENDOR – SIEMENS WATER TECHNOLOGIES

The UV unit was provided by Siemens Water Technologies and represented a commercial version of their H-4XE-HO (2W-1B-1C) open channel UV disinfection system. Siemens Water Technologies also provided documentation and calculations necessary to demonstrate the system's conformity to commercial systems, hydraulic scalability and test protocol requirements. Siemens Water Technologies UV production operations are located in New Jersey. Dr. Bertrand Dussert is the primary contact for Siemens. He can be reached at:

Siemens Water Technologies Corp.
1901 West Garden Road
Vineland, NJ 08360
Bertrand Dussert
Bertrand.Dussert@siemens.com
(856) 507-4144

SECTION 3

TECHNOLOGY DESCRIPTION

3.1 SIEMENS WATER TECHNOLOGIES OPEN CHANNEL UV DISINFECTION SYSTEM

The O&M manual for the H-4XE-HO (2W-1B-1C) open channel UV disinfection system is provided as Appendix B. Figure 3-1 provides schematics of the horizontal lamp reactor and its placement in the channel. Refer to Section 3.2 for a description of the test stand and photos of the system components and installation.

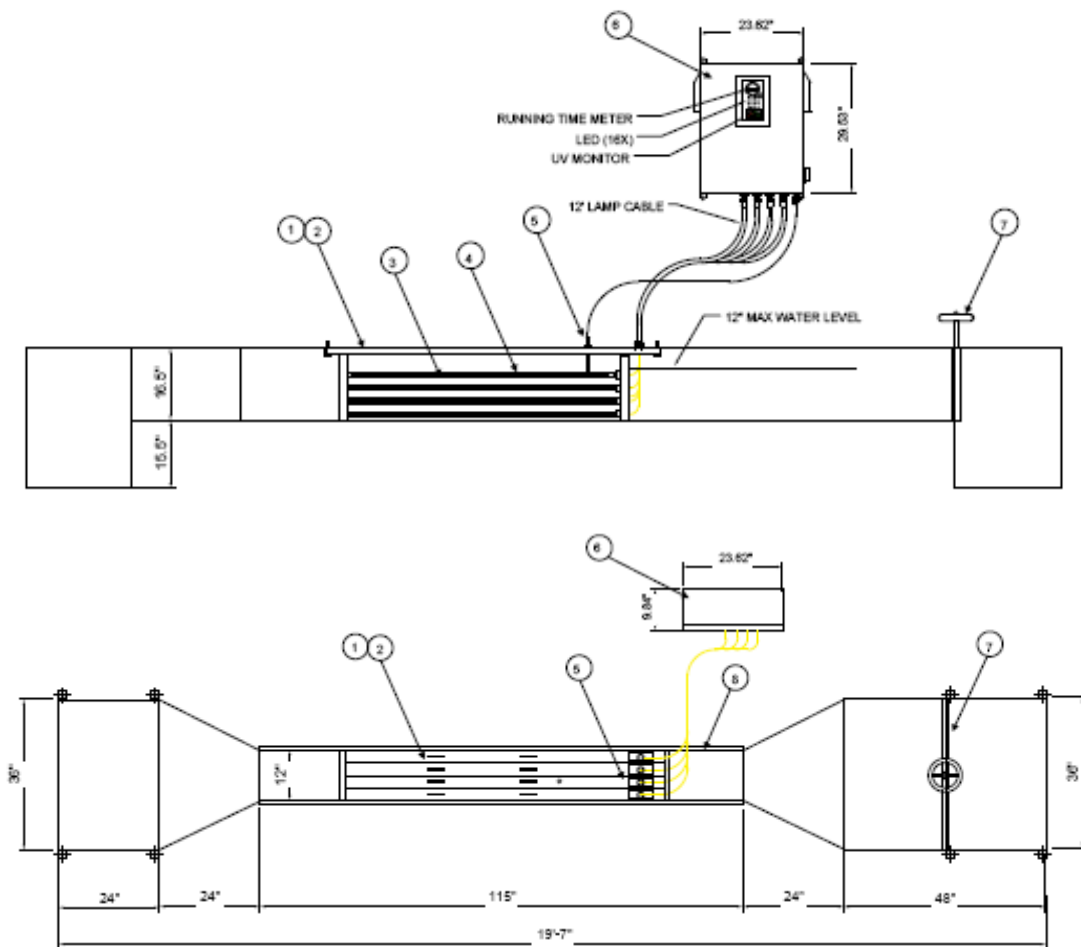

Figure 3-1. Plan and elevation schematic of H-4XE-HO (2W-1B-1C) reactor and channel assembly.

3.1.1 Lamps and Sleeves

The H-4XE-HO (2W-1B-1C) UV unit supplied by Siemens utilizes 16 high-output, low-pressure lamps, oriented horizontally and parallel to the direction of flow (Figure 3-1). The lamps are housed in two modules, each containing eight lamps. Each lamp has a UV output of approximately 60 Watts at 254 nm and a total power draw of approximately 170 Watts. The lamps are approximately 60 in. long and each lamp is housed in a clear fused quartz sleeve to isolate and protect the lamp from the wastewater. The sleeves have only one open end, which are sealed with the lamp power cable plug. These quartz sleeves are 70 in. long, have an outer diameter of 28 mm, a wall thickness of 1.5 mm and a UV transmittance of 91%.

3.1.2 Lamp Output Attenuation by Aging and Sleeve Fouling

The total intensity attenuation factor was set by Siemens at 80%, based on the combined effects of a sleeve-fouling factor of 90% and a lamp-aging factor (EOLL factor) of 90%. This aging factor is set at a minimum of 12,000 operating hr.

3.1.3 Sleeve Cleaning System

The H-4XE-HO (2W-1B-1C) UV disinfection system provided by Siemens is equipped with automatic sleeve wiping systems. The performance of the wipers was not evaluated as part of this dose-delivery verification. However, the wipers were used to clean the sleeves at the beginning of each validation test day.

3.1.4 Electrical Controls

The lamps in the H-4XE-HO (2W-1B-1C) unit are powered from electronic ballasts mounted vertically in a remotely located enclosure. Each ballast powers two lamps in parallel so that one lamp failure does not cause the peer lamp to turn off. The ballast controls are located in the control cabinet. The ballast/control panel for the unit allows for lamp power dimming. This function was used in the verification test in order to simulate the combined attenuation factor, but dimming the lamps is not usually a control strategy for this commercial unit. The control cabinet supplied for this ETV validation was powered via an onsite generator that supplied 230V delta power.

3.1.5 UV Detectors

The disinfection system used for this verification was equipped with a SLS SiC004 UV intensity sensor certified to DVGW Standards. One sensor was installed on the top cover of the lamp rack, approximately 2 cm from a lamp sleeve in the top row. The sensor includes a remote,

dedicated amplifier that operates on a 4-20 mA signal. The sensor has a wavelength selectivity of 96% between 200 nm and 300 nm and a linear (1%) working range of 0.01 to 20 mW/cm². The stability of the sensor is 5% over 10 hr and a range of temperatures from 2 to 30°C.

3.1.6 Design Operational Envelope

The H-4XE-HO (2W-1B-1C) system verified in this ETV was designed to operate at flow rates up to 868 gpm (1.25 mgd). The intensity monitor can be set for an appropriate reading depending on the application, and the intensity alarm can be set to activate when a low dose condition exists. Three common factors can contribute to a low dose condition: attenuation of UV output by excessive lamp aging, quartz sleeve fouling, or low water transmittance conditions. The exact setting depends on the specific application requirements. In terms of intensity reduction due to lamp aging and quartz fouling, the suggested operational protocols comply with the conditions in this ETV. Quartz fouling of 90% and lamp age intensity reduction of 90% (at 12000 hr) were simulated during this ETV.

The commercial unit is typically designed to operate at 100% input power (no dimming). The primary operating variables are the water UVT and flow rate. Within the scope of this ETV, dose-delivery performance was verified at nominal UVT levels between 50% and 80% transmittance at 254 nm. The flow rates were varied to yield reduction equivalent doses (REDs) between approximately 10 and 100 mJ/cm². In conformance with the WW Protocol and ETV protocol (2002), a single bank was tested. The single bank is considered additive if placed in series. The test unit is a 16-lamp version of the H-4XE-HO (2W-1B-1C). Scale-up is limited to a factor up to 10 times this number of lamps (160) in a single bank (while maintaining the same liquid velocity). Scale-down (less than 16 lamps/bank) is not considered appropriate.

3.2 UV TEST STAND SPECIFICATIONS

3.2.1 Test Channel

The reactor was housed in an open stainless steel channel, 21 ft-7 in. long, with lamps oriented horizontally and parallel to the flow direction. The flow from the 12-in. influent pipe first entered a 24-in. long, 36-in. wide by 32-in. deep influent box (Figure 3-1). From the influent box, the flow entered a 12-in. wide channel, with a liquid depth of 12-in. The test reactor was located at the midpoint of this 115-in. long section. At the end of this test section, an expansion section was provided, discharging to an effluent box equivalent to the influent box. Flow exited the channel through a 12-in. pipe to the dump tank. Figure 3-2 presents photos of the influent and effluent piping arrangements. The horizontal-lamp unit channel was the smaller of the two shown in either photo.



Figure 3-2. Influent (top) and effluent (bottom) piping configuration for the H-4XE-HO (2W-1B-1C) test unit channel.

The test channel had a stilling plate installed at the junction of the influent box and test section to provide good flow distribution upstream of the test unit. An adjustable weir gate was installed at the effluent end so that the water level inside the channel could be controlled. Photographs of the stilling plate and adjustable weir are provided in Figure 3-3. Figure 3-4 shows the reactor installed in the channel. The lamps and quartz sleeves are oriented horizontally (top photo). Service to the lamps is through cables to the control panel (bottom photo). The power/control panel is shown in Figure 3-5.

3.3 VERIFICATION TEST CLAIMS

The overall objective of this ETV was to validate the performance of the Siemens Water Technologies H-4XE-HO (2W-1B-1C) open channel UV disinfection system at water quality (UVT) and dose (RED) conditions reflective of secondary effluent and reuse applications. The total attenuation factor of 80% was selected by Siemens as a combined effect of 90% sleeve fouling factor and 90% of end-of-lamp-life factor. This attenuation was mimicked by lowering the test water transmittance. Within this goal, seven specific objectives were fulfilled:

1. Verified the performance difference between power turndown and UVT turndown at the same operating conditions to mimic the total attenuation factor.
2. Verified the flow-dose relationship for the system at nominal UV transmittances of 50%, 65% and 80% for a dose range of 5 to 25 mJ/cm² using a biological surrogate with a relatively high sensitivity to UV (T1 coliphage).
3. Verified the flow-dose relationship for the system at a nominal UV transmittance of 50%, 65% and 80% for a dose range of 10 to 40 mJ/cm² using a biological surrogate with medium sensitivity to UV (Qβ coliphage).
4. Verified the flow-dose relationship for the system at a nominal UV transmittance of 50%, 65% and 80% for a dose range of 20 to 80mJ/cm² using a biological surrogate with relatively low sensitivity to UV (MS2 coliphage).
5. Adjusted the observed RED performance results by a validation factor in order to account for uncertainties associated with the verification tests.
6. Verified the power consumption and headloss of the unit.
7. Developed a dose-algorithm to control dose-delivery on a real-time basis, based on the system's primary operating variables.



Figure 3-3. Influent stilling plate and effluent weir gate for the Siemens H-4XE-HO (2W-1B-1C) UV unit test channel.

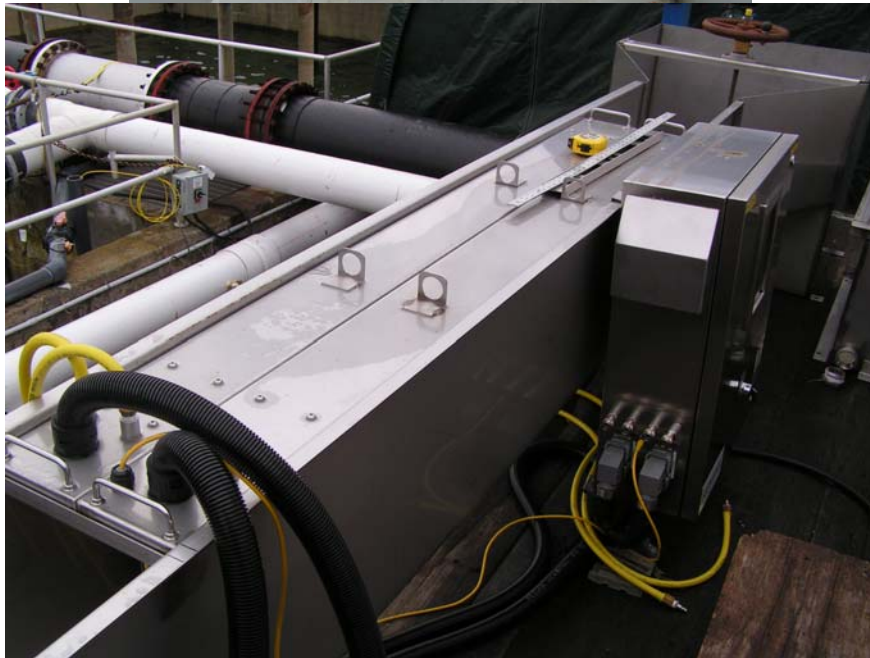

Figure 3-4. Photos of H-4XE-HO (2W-1B-1C) reactor installed in channel.



Figure 3-5. Photo of unit power panel.

SECTION 4

PROCEDURES AND METHODS USED DURING VERIFICATION TESTING

4.1 GENERAL TECHNICAL APPROACH

By its nature, the effectiveness of UV is dependent on the upstream processes used for pretreatment, particularly for solids, oil/grease and organics removal. The UV design basis typically developed for a UV system application incorporates the characteristics of the wastewater to be treated, established to reflect a planned level of pretreatment, and the expected variability in quality and quantity. Finally, the dose required to meet specific target levels is determined, typically established from direct testing (e.g., collimated-beam dose-response methods) of the wastewaters or similar wastewaters. Once this “design basis” is established, independent of the UV equipment, the next step is to select equipment that can meet these specific dose requirements under the expected wastewater characteristics.

The ETV technical objective is met by demonstrating, or verifying, the ability of a specific system to deliver an effective dose. This is the Reduction Equivalent Dose (RED) actually received by the microbes in the wastewater. Direct biosimetric procedures are used to estimate the RED for specific reactor configurations, typically as a function of the hydraulic loading rate and the water UVT. Biosimetry is a viable and accepted method per current protocols and has been used successfully for many years, whereby the results are often applied to qualification requirements in bid documents for wastewater treatment applications.

Biosimetry uses a known microorganism that is cultured and harvested in the laboratory and then subjected to a range of discrete UV doses. These doses are applied with a laboratory-scale, collimated beam apparatus, which can deliver a known, accurately measured, dose. Measuring the response to these doses (log survival ratio), a dose-response relationship is developed for the specific organism. A culture of the same organism is then injected into the large-scale UV test unit, which is operated over a range of hydraulic loadings (thus yielding a range of exposure times). The response of the organism can then be used to infer, from the laboratory-based dose response relationship, the reduction equivalent dose that was delivered by the UV unit.

4.1.1 Site Preparation

The testing for this ETV validation was conducted at the UV Validation and Research Center of New York (UV Center – refer to Figures 2-2, 2-3 and 2-4). Figure 4-1 presents the test stand process flow diagram for conducting the dose delivery verification assays, including

sampling locations. Supporting instrumentation included a flow meter, UV/Vis spectrophotometer, radiometer with an appropriate UV sensor, turbidity meter, power meter, powerlogger and dataloggers for other operational parameters.

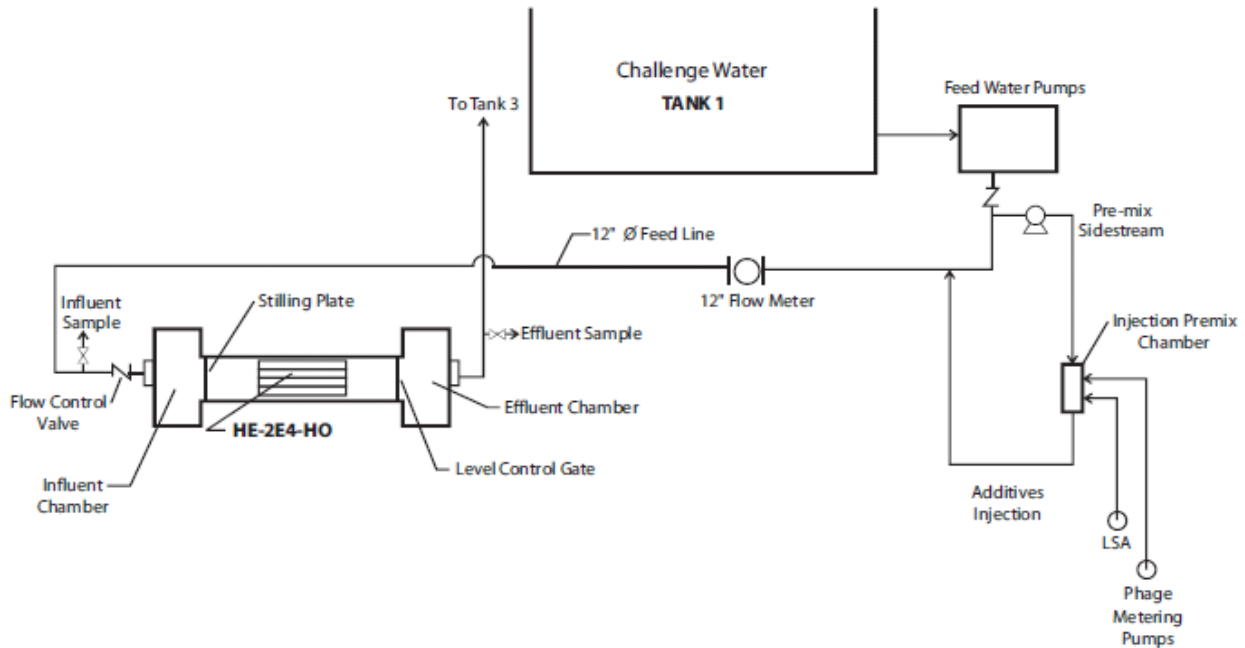

Figure 4-1. Process flow diagram for the H-4XE-HO (2W-1B-1C) UV System validation test stand.

The UV output of the system at 254 nm was measured by a single duty sensor. This was a SLS SiC004 UV intensity sensor certified to DVGW Standards, connected to a remote, dedicated amplifier operating on a 4-20 mA signal. The UV transmittance of the test water is also critical. A laboratory-grade GenTech Model 1901 Double Beam UV/Vis spectrophotometer was maintained at the UV Center for measuring the UV transmittance of samples. Transmittance was also verified at the microbiology laboratory with a second GenTech 1901 spectrophotometer.

4.1.2 Water Source

Water for cleaning and test purposes was drawn from a local fire hydrant, which is piped to the source-water tanks. Lignin sulfonate (LSA) was used to adjust the UVT of the challenge water.

4.1.3 Challenge Water and Discharge Tanks

The UV Center uses two large concrete storage tanks for the challenge water and two additional concrete tanks for effluent water storage prior to final discharge to the treatment plant (Figure 2-3). For this test, challenge water was stored in Tank 1 (0.75 million gallons). Effluent water was stored in Tank 3 (1.3 million gallons).

4.1.4 Feed Pumps

The challenge waters were pumped to the test unit, or recirculated to the challenge water tank, with one of eight Godwin centrifugal pumps. Each pump is diesel-powered to provide flow rates up to 5500 gal/min. The pumps are permanently mounted alongside Tank 1 and Tank 2, as shown in Figure 2-4.

4.1.5 Flow Meter

Flow to the system was metered using a 12-in. Krone magnetic flow meter, installed in a 12-in. pipeline with a straight run of ten pipe diameters before and five pipe diameters after the flow meter to reduce turbulence that could impact meter performance. The flow meter calibration was regularly checked before testing using a timed volume drawdown method (Section 6.1.1).

4.2 DISINFECTION UNIT STARTUP AND CHARACTERIZATION

4.2.1 100 Hour Lamp Burn-In

Before dose delivery verification testing began, the lamps were aged for 100 hr to allow the lamp intensity to stabilize. The lamps were turned on at 100% power with water recirculating through the channel at a rate of approximately 900 gpm to prevent the lamps from overheating. The burn-in period spanned five days. Log sheets are provided in Appendix C.2.1. The powerlogger was not functional during the burn-in period, but manual power measurements were made to monitor the period.

4.2.2 Power Consumption and Flow Characterization

4.2.2.1 Power Consumption Measurement

For the purposes of this test program, the total system real power consumption was recorded during the actual bioassay testing and during technical tests that required the unit to be on. A Mitchell Instruments powerlogger was connected to the control panel to record the power draw (230V delta phase) from the onsite generator.

4.2.2.2 Headloss Measurements

Measurements of headloss were conducted by attaching staff gauges to the inside of the reactor channel. The channel was leveled within 0.5 cm before the start of the testing. The zero-level installation of the staff gauges was established with stationary water in the channel. The vertical datum was the bottom of the channel under the UV unit, so the measurements represent the depth of water in the channel

For this verification, the water level was measured at two positions and eight different flow rates. The flow rates used for measuring the headloss were the minimum and maximum flow rates used for validation and several intermediate flow rates. The measurement positions were located approximately 6 in. upstream and 6 in. downstream of the lamp bank.

4.2.2.3 Velocity Profile Measurement

The NWRI/AwwaRF *Ultraviolet Disinfection Guidelines for Drinking Water and Water Reuse* (2003) recommends that commissioned systems should have velocity profiles that are equivalent or better than demonstrated by the validation test unit. The guidance protocol states that the velocity measurement points should be 6 to 12 cm apart; for reactors larger than 25-cm wide or diameter, a minimum of nine points should be used for establishing the velocity profile. As such, a 3 × 3 measurement matrix was designed for the cross-section of the Siemens H-4XE-HO (2W-1B-1C) UV system channel, as illustrated in Figure 4-2. These measurements were conducted at flow rates 0.2 and 0.8 mgd. A specially designed frame was used to position the velocity meter at the desired location inside the channel. At each location, three readings of flow velocity were recorded. The velocity meter was a Marsh-McBirney Flow-Mate Model 2000. Each reading was an integrated average recorded by the meter over a period of 7 seconds.

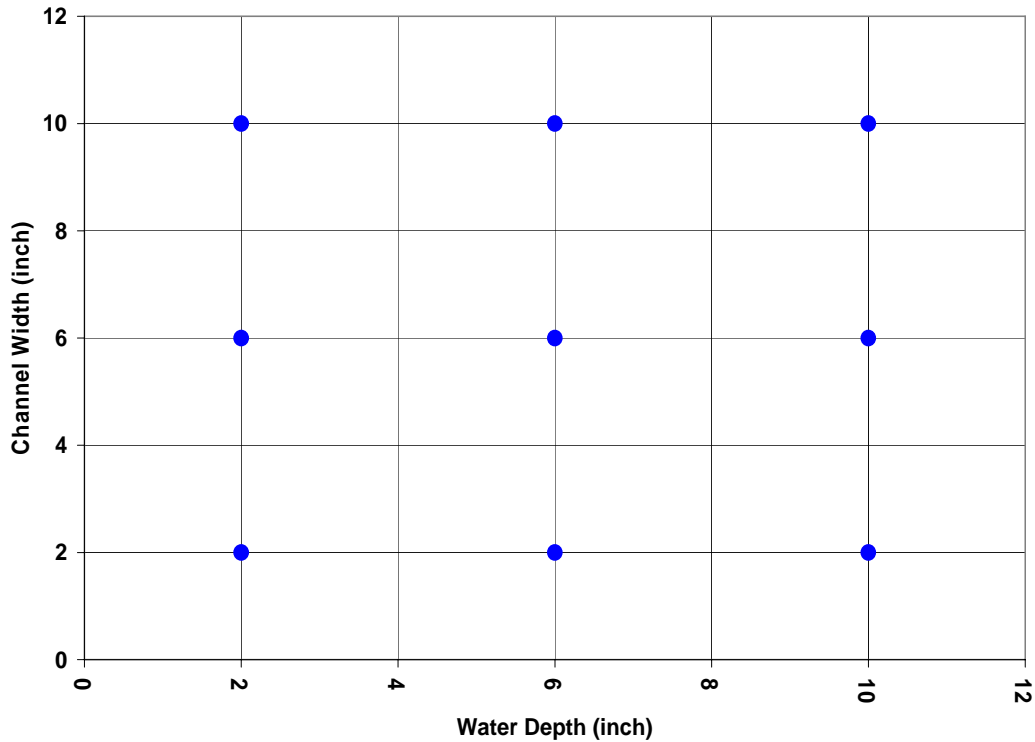

Figure 4-2. Velocity profile measurement matrix.

4.2.2.4 Shakedown Flows

Two shakedown flow tests were conducted. This allowed an initial calibration run to determine if power turndown or UVT adjustment would be used to simulate the total intensity attenuation factor. This also allowed a “test run” to familiarize the technicians with the equipment operation and sampling scheme. These flow tests were conducted using the methodology described in Section 4.4.

4.3 BACTERIOPHAGE PRODUCTION AND CALIBRATION

4.3.1 Bacteriophage Propagation

Three different bacteriophages were used for validation testing of the H-4XE-HO (2W-1B-1C) unit: MS2, T1 and Q β . All three of the microorganisms are F-specific RNA bacteriophages. The MS2 and Q β were ATCC 15597-B1 and ATCC 23631-B1, respectively, and the host *E. coli* strain was ATCC 23631. T1 originates from an isolate by GAP Enviromicrobial Services (London, Ontario) Canada. T1 is assayed with *E. coli* CN13 ATCC 700609 as the host organism.

The propagation procedure was based on ISO 10705-1 (1995), which was refined to produce the large volumes needed for biosimetry. For cultures of all three bacteriophages, the host strain (*E. coli*) was grown at 37°C in Trypticase yeast-extract glucose broth until the log-growth phase was reached. This time was determined by previously completing three growth curves of the same host-strain working culture. When the optimum log-growth phase was reached, the stock solutions were pipetted into the bacterial growth cultures to start the infection, which was allowed to continue overnight. During the following day, the culture media was filtered through 0.45 and 0.22 µm filters to remove cell lysate, and to remove any other bacteria that may be present. The stock solution was stored over chloroform at 4°C.

4.3.2 Dose-Response Determination

The dose-response behavior of the bacteriophage stocks and seeded influent samples were determined using a collimated beam apparatus residing in HydroQual's laboratory (Figure 4-3). The lamp housing is a horizontal tube, constructed of an opaque and non-reflective material, ventilated continuously via a blower for ozone removal and for temperature control. The collimating tube, also constructed of an opaque non-reflective material, extends downward from the center of the lamp housing. The housing contains two conventional G64T5L low-pressure mercury discharge lamps, which emit almost all of their energy at 254 nm. The lamp temperature was monitored continuously via a digital thermometer with a thermocouple mounted on the lamp skin. A Petri dish was used to hold the sample for exposure and used a magnetic mixing system to gently stir the microbial suspension. Typical irradiances were 0.2 mW/cm² at the surface of the liquid. The Petri factor was approximately 0.96. A manually operated shutter was present at the bottom of the collimating tube.

The irradiance or intensity of the collimated beam apparatus was measured using an International Light IL-1700 radiometer with an SED 240 detector and a NS254 filter. The radiometers and detectors were calibrated on a regular basis by International Light and are accompanied by NIST traceable certifications. The calibration interval is approximately three months, and is usually selected to bracket specific validation work. Per UVDGM guidance and the WW protocol, a second detector was used to check the duty detector when collimated beam testing was conducted. The two readings must, and did, agree within 5% of their mean reading.

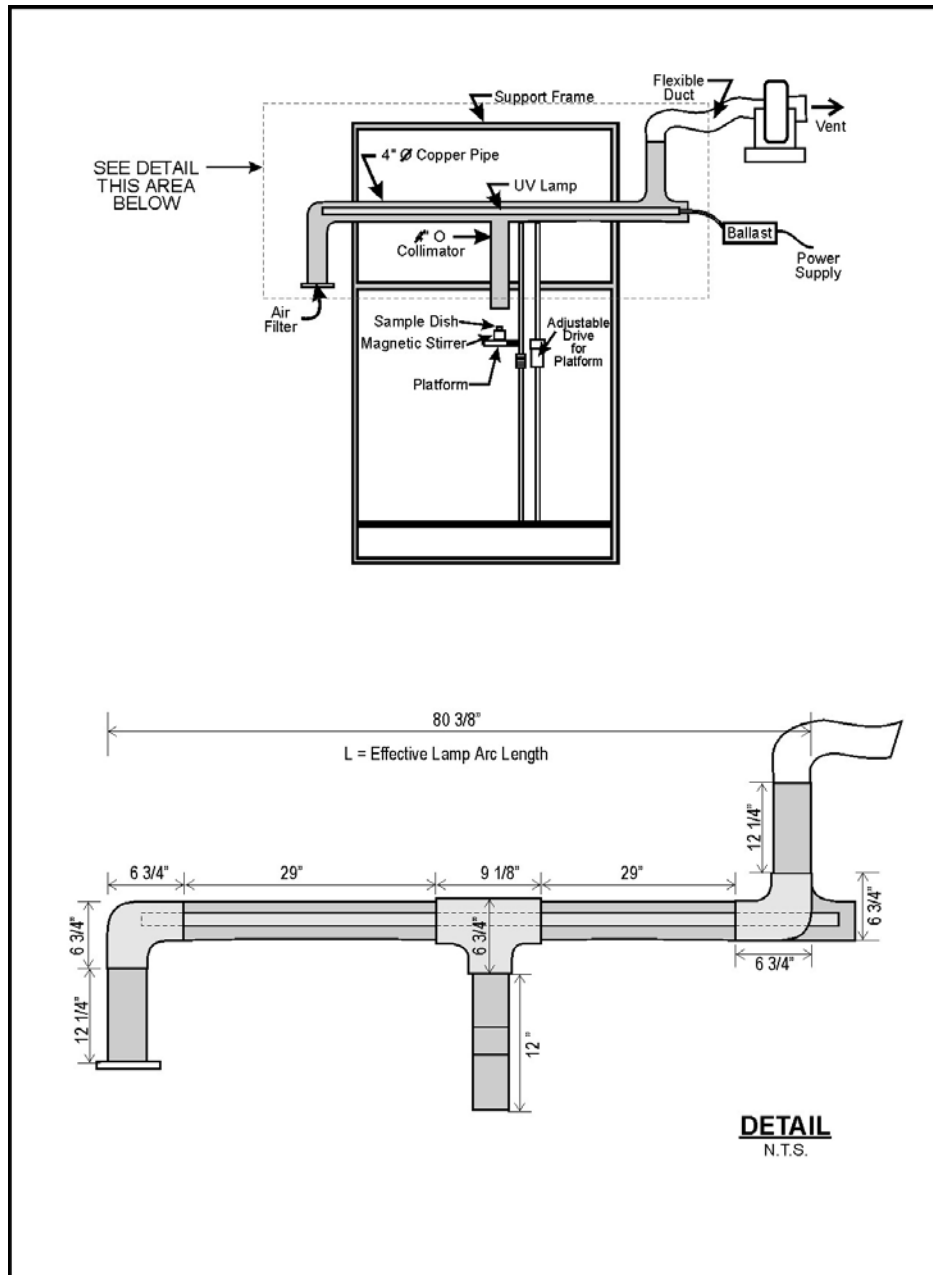

Figure 4-3. HydroQual collimating apparatus for conducting Dose Response tests.

All microbiological samples were exposed in a Petri-type dish, with straight sides and a flat bottom. The outer perimeter of the sample container was always within the diameter of the collimator. The intensity was measured at the beginning and at the end of the dose response series. The dose-delivery calculations were based upon the methods stated in the UVDGM (USEPA, 2006), Appendix C. The irradiance field of the collimated beam was wide enough to completely contain the sample dish with an inside diameter of 87 mm. The reflectance of the

sample surface was 2.5%, and the sample depth was 1.3 cm. In brief, the dose is calculated using:

$$D_{CB} = E_s P_f (1 - R) \frac{L}{(d + L)} \frac{(1 - e^{-\ln(\%T)d})}{\ln(\%T)d} t$$

Where:

- D_{CB} = UV dose (mJ/cm²)
- E_s = Average incident UV intensity (before and after irradiation) (mW/cm²)
- P_f = Petri Factor (unitless)
- R = Reflectance at the air-water interface at 254 nm (unitless)
- L = Distance from lamp centerline to suspension surface (cm)
- d = Depth of the suspension (cm)
- $\%T$ = UV transmittance at 254 nm (cm⁻¹)
- t = Exposure time (s)

For this ETV, a total of 24 dose-response runs were conducted, 12 for MS2, 6 for T1, and 6 for Q β . All dose response runs were conducted with seeded challenge waters at UVTs ranging from 43.5% to 80.0 % transmittance. A single dose-response series consisted of a minimum six doses to achieve a range of inactivation values. For MS2, these doses were typically 0, 10, 20, 40, 60, 80, and 100 mJ/cm²; for Q β , the doses were typically 0, 5, 10, 20, 30, 40, and 60 mJ/cm²; and for T1, 5, 10, 15, 20 and 25 mJ/cm². Extrapolations were not made beyond the minimum and maximum dose levels actually tested, so in certain instances, higher doses may also have been analyzed, if necessary.

At least one seeded influent sample was collected from the influent sample port for each day of flow testing and used for the collimated-beam, dose-response analysis. These were conducted on the same day that the flow-test samples were enumerated (within 24 hours of collection). The influent dose-response tests were typically conducted at the minimum UVT tested on that day. Additionally, one dose-response series was conducted for each challenge organism with the source water at the highest UVT, unadjusted with lignin sulfonate.

4.4 BIODOSIMETRIC FIELD TESTS

4.4.1 Lamp Sleeve Preparation

Before each flow test series, the lamp sleeves were scrubbed with sponges and an acidic cleaning solution (e.g., Lime Away). The sleeves were then thoroughly rinsed to remove the cleaning solution.

4.4.2 Challenge Water Batch Preparation

Before the start of a series of biosimetric flow tests, the test stand was prepared. The source water staging tank (Tank 1) was filled with an adequate amount of dechlorinated (using sodium sulfite) water, and characterized for pH, temperature, turbidity, and UVT. Samples were tested to assure that total chlorine was non-detectable at the 0.05 mg/L level. Depending on the test matrix planned for the day, the UVT of the tank contents were either adjusted on a batch basis, or “on-the-fly” as each flow test was performed. UVT adjustments were made with a lignin sulfonate (LSA) solution injected into the test stream. The UVT measurements, made with the Gentech Model TU-1901 spectrophotometer, are reported with observed REDs. Tests were conducted with water turbidities consistently less than 2 NTU.

4.4.3 Biosimetric Flow Tests

Biosimetric flow tests were conducted by pumping the test water, with the appropriate injection of coliphage and lignin sulfonate, through the channel at the specified flow rate. Enough time was allowed for at least five volume changeovers in the lamp assembly, the flow rate was checked again and sampling commenced. Water that had passed through the test unit was wasted to Tank 3.

Grab samples were collected in sterile, 120-mL single-use specimen cups. Influent samples were collected at a sample port located two 90° bends prior to the influent box. Effluent samples were collected from the sample port located after the effluent box and one 90° bend. Influent and effluent samples were collected simultaneously and in triplicate, resulting in six samples for each flow test. The samples were placed in separate influent and effluent closed (dark) coolers with ice, and transported to the lab the same day. Samples were analyzed the next day.

4.4.4 Transmittance Measurement

The transmittance of the challenge waters was measured on every influent sample and on the seeded influent samples used for dose-response analysis. The transmittance was measured in the field and in the laboratory at 254 nm in a quartz cell with a path-length of 1 cm, using a GenTech 1901 spectrophotometer at each location. The zero reference was laboratory deionized reagent water. The instruments were checked periodically with NIST-traceable holmium oxide and potassium dichromate standards.

4.4.5 Bacteriophage Enumeration

The density or concentration of viable bacteriophage in the flow test and dose-response samples was determined using ISO 10705-1 and USEPA UVDGM (Appendix C) methods.

Briefly, samples containing MS2, T1 or Q β bacteriophage were serially diluted in peptone-saline dilution tubes to a dilution determined to be appropriate from experience or from screening runs. Then, 1 mL of this diluted sample was mixed with 1 mL of host *E. coli*, and 2.5 mL semi-solid growth medium. This mixture was plated onto an agar plate and allowed to grow overnight (~16 hours) at 37°C. This double-plating approach employed trypticase yeast-extract glucose broth (TYGB) as the growth medium. Each sample was plated at two dilutions in duplicate, resulting in four plates for each sample. Only plates with 30-300 pfu were deemed valid for analysis. The acceptable data was then averaged geometrically and corrected for the dilution to determine the bacteriophage concentration (pfu/mL) in the test solution.

4.4.6 Dose Determination

When reducing the dose-response data, the N_0 used for computing inactivation was estimated by regressing the log of the titers of all dosed and undosed samples versus applied dose, and taking the y-intercept predicted by a second-order regression equation (UVDGM, November 2006). This results in a N_0 value for each dose-response series. Then the inactivation for each dosed sample was calculated with:

$$\text{Log Inactivation} = \log(N_0) - \log(N)$$

Where :

Inactivation = Coliphage inactivation in log units.

N_0 = Titer of undosed sample from y - intercept.

N = Coliphage titer (pfu/mL) in dosed sample.

The dose-response calibration for each bacteriophage was quantified by fitting a second-order polynomial to the validation dose-response data, thereby generating a relationship where dose is a function of survival ratio (Section 5.2). All flow test survival ratios were then converted to Reduction Equivalent Dose (RED) with the use of this relationship (Section 5.3).

4.5 EXPERIMENTAL TEST MATRIX

For reference, the proposed VTP validation matrix for the H-4XE-HO (2W-1B-1C) is presented in Table 4-1. This was constructed with HydroQual's simplified model. Once data were collected for the system, the final matrix was modified to assure that the boundary limits and interpolation points were properly covered.

Table 4-1. Validation Conditions for Siemens H-4XE-HO (2W-1B-1C) UV System

Lamps	UVT (%/cm)	Flow (mgd)	Predicted RED (mJ/cm ²)	T1	MS2	QB
16	80	0.30	85.96		1	
16	80	0.40	70.41		1	
16	80	0.50	60.32		1	
16	80	0.80	43.54		1	
16	80	1.00	37.30		1	1
16	80	1.25	31.96		1	
16	80	1.50	28.16			1
16	80	2.00	23.07	1	1	1
16	80	3.00	17.41	1		
16	65	0.20	72.84		1	
16	65	0.30	54.99		1	
16	65	0.50	38.59		1	1
16	65	0.80	27.86		1	
16	65	1.00	23.86		1	1
16	65	1.25	20.44	1	1	1
16	65	1.50	18.01			
16	65	2.00	14.76	1		1
16	65	3.00	11.14	1		
16	50	0.20	52.73		1	
16	50	0.30	39.81		1	1
16	50	0.40	32.61		1	
16	50	0.50	27.94		1	1
16	50	0.60	24.62		1	
16	50	0.80	20.17	1	1	1
16	50	1.00	17.28	1	1	
16	50	1.40	13.68	1		
16	50	1.60	12.47	1		
16	50	2.00	10.68			1
16	50	3.00	8.07	1		
16 (OFF)	80	2.00	0.00		1	
16 (OFF)	80	2.00	0.00	1		
16 (OFF)	80	2.00	0.00			1

SECTION 5

RESULTS AND DISCUSSION

5.1 DISINFECTION UNIT STARTUP AND CHARACTERIZATION

5.1.1 Power Consumption

The power consumption of the Siemens H-4XE-HO (2W-1B-1C) system was continuously logged when operating. The total attenuation condition was simulated through UVT adjustment, not power turn-down. This allowed for direct monitoring of total real power consumption by the H-4XE-HO (2W-1B-1C) unit at the power level (at the PLC) of 100. Siemens states that this power level is considered the nominal input power rating for this system. At a PLC setting of 100, the mean total power input was 2.74 kW, or 171 W/lamp.

5.1.2 Headloss Measurements

Headloss estimates were derived from the hydraulic profile data shown in Table 5-1, and are presented graphically in Figure 5-1. Two sample locations (immediately before and after the unit) were used at eight different flow rates. Note that the influent depth was held constant by adjusting the downstream weir height.

Table 5-1. Depth Measurements to Compute Headloss

Flow Rate (mgd)	Water Depth (in)		Headloss (in)	
	Influent	Effluent	Differential	1 Module
0.20	12	12.0	0.03	0.03
0.30	12	11.9	0.13	0.13
0.40	12	11.7	0.31	0.31
0.50	12	11.4	0.56	0.56
0.61	12	11.1	0.88	0.88
0.81	12	10.8	1.25	1.25
1.00	12	9.6	2.38	2.38
1.26	12.5	8.5	4.00	4.00

For the H-4XE-HO (2W-1B-1C) system the headloss (in. of water) across one 16-lamp reactor is shown in Figure 5-2 as a function of flow (mgd). Headloss can be approximated by the relationship:

$$\text{Headloss (in. of water)} = 3.160 (\text{flow, mgd})^2 - 0.938 (\text{flow, mgd}) + 0.148$$

It is important to understand that the headloss was measured within the cited flow range and should be extrapolated for flow rates outside this range.

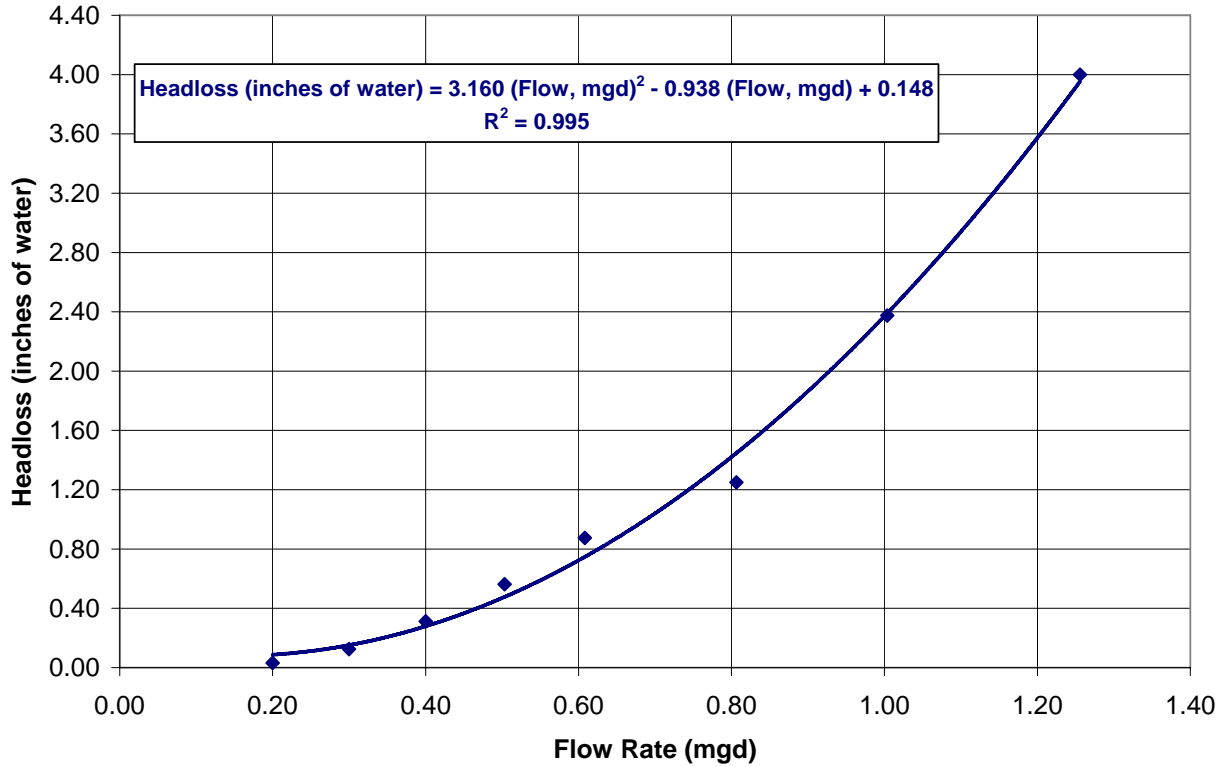

Figure 5-1. Headloss through a single H-4XE-HO (2W-1B-1C) reactor as a function of flow rate.

5.1.3 Intensity Sensor Characterization

The output of the duty sensor is a 4-20 mA signal, converted to a percentage at the PLC. The relationship of mA to Sensor (%) is shown in Figure 5-2, and can be expressed as:

$$\text{Sensor (\%)} = 6.25 \times (\text{Sensor, mA}) - 25$$

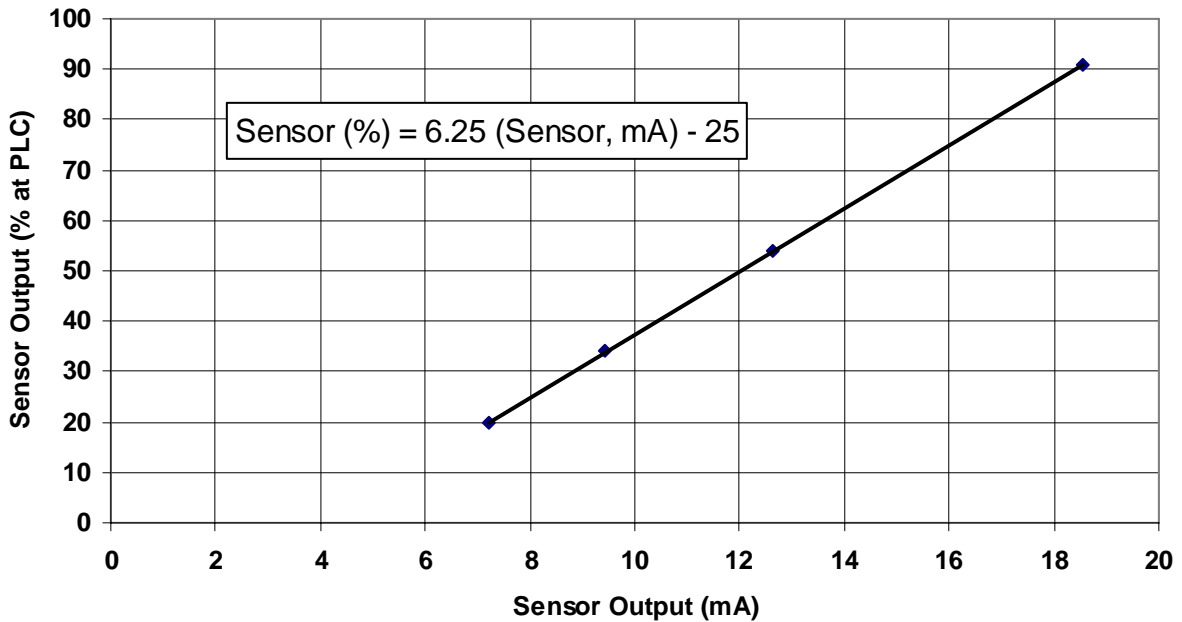

Figure 5-2. Relationship of sensor output (mA) and PLC sensor reading (%).

5.1.3.1 Sensor Output with UVT and Intensity Attenuation Power Setting

Sensor readings, expressed in mA, are plotted as a function of the UVT in Figure 5-3. Recall that the Siemens system's equivalent 100% input power is set at the PLC 100 power setting. At the highest UVT (80%), the mA reading at 100% input power was 18.56 mA. This is the nominal sensor reading, S_0 . As stated earlier, Siemens has set the combined intensity attenuation factor at 0.8. This is equivalent to the ratio of the intensity reading at the attenuated position (I) to the nominal intensity at full input power (I_0). Based on the sensor output as a 4 to 20 mA signal, the attenuated sensor reading can be determined:

$$I/I_0 = (S - 4) / (S_0 - 4)$$

Where S and S_0 are the sensor mA readings at the attenuated and full power outputs, respectively. From this relationship, the attenuated sensor output is calculated to be 15.9 mA. UVT turndown was selected as the method for simulating the attenuation factor when validating the Siemens H-4XE-HO (2W-1B-1C) system.

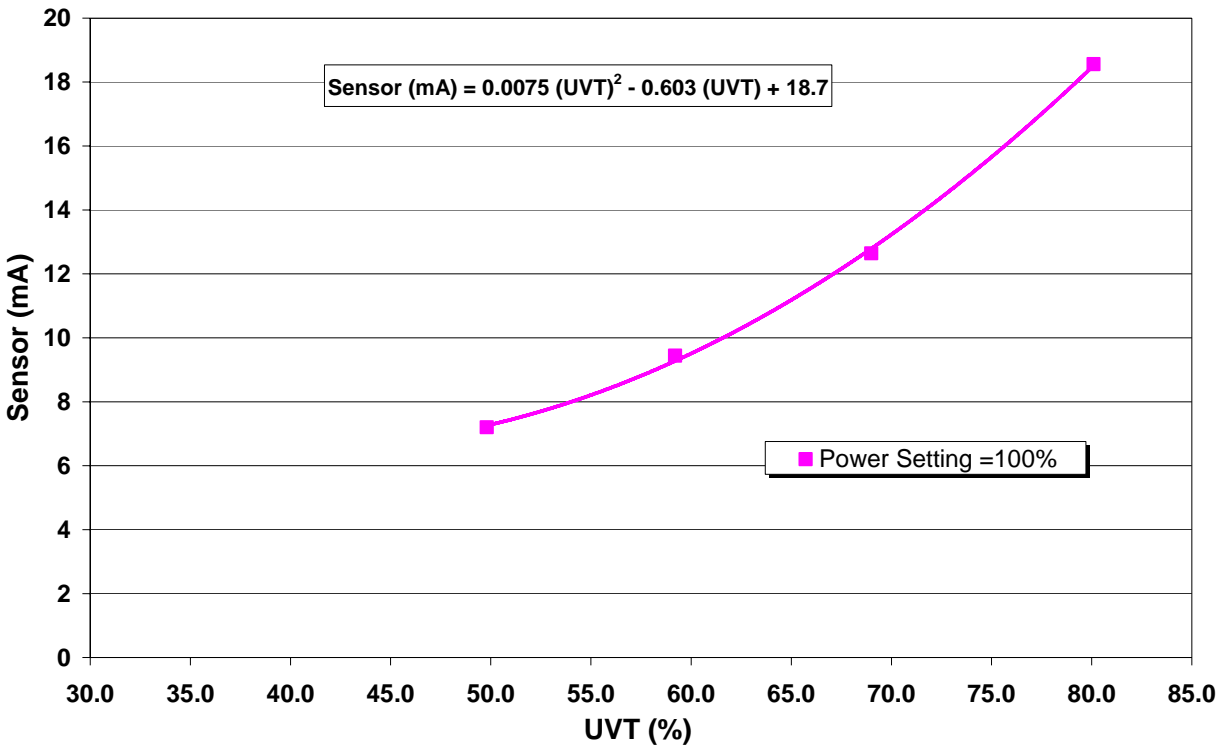

Figure 5-3. Sensor reading (mA) as a function of UVT.

5.1.3.2 Sensor Uncertainty QA Validation

Sensor uncertainty was characterized for the H-4XE-HO (2W-1B-1C) reactor following UVDGM protocols. The results of the comparisons at high and low UVT are presented in Table 5-2, where the individual sensor signals have been reduced to the appropriate averages for each test condition. Sensor readings, in mA, were used to calculate the variance between the duty and reference sensors. Table 5-2 shows that there was no variance observed when comparing the two reference sensors to the average reference sensor reading (0.0%), nor when comparing the duty sensor reading to the average reference sensor reading.

The QA requirements are (1) readings by each of two or three reference sensors should be within 10.0% of the average of the reference sensor readings, and (2) the duty sensor should be within 10.0% of the average reference sensor. Both of these criteria were met. As will be discussed in a later section, meeting these QA criteria allows one to ignore sensor uncertainty when developing the validation factor.

Table 5-2. Sensor Intercomparison Variance Analysis

Power (PLC%)	UVT (%T/cm)	Duty Sensor Reading		Reference Sensor ID	Reference Reading (% of 4- 20 mA)	Reference Reading	Duty from Avg Ref (mA)	Duty Sensor Pass/Fail	Ref from Avg Ref	Ref Sensor Pass/Fail
		(% of 4- 20 mA)	mA							
100	80.1	91.0	18.6	R1	93.0	18.6	0.0%	Pass	0.0%	Pass
				R2	95.0	18.6				
100	49.8	20.0	7.2	R1	21.0	7.2	0.0%	Pass	0.0%	Pass
				R2	20.0	7.2				

5.1.4 Velocity Profile Measurements

Cross-sectional velocity measurements were taken at 0.2 and 0.8 mgd. Per guidance in the NWRI/AWWARF *Ultraviolet Disinfection Guidelines for Drinking Water and Water Reuse* (2003), the mean velocity at any measured cross-sectional point of a commissioned system should not vary by more than 20% from the theoretical average velocity (i.e., flow divided by the cross-sectional area). Further, the commissioned system should exhibit velocity profiles that are equivalent or better than those exhibited by the validated test unit. This is particularly important if there is scale-up from the test unit.

The full record of velocity measurements is compiled in Appendix C. Overall, a general observation is that the velocity profiles were variable at 0.8 mgd. The effluent measurements tended to be outside the targeted range. The influent measurements at 0.8 mgd were fairly stable and less variable than the effluent. At 0.2 mgd, velocity profiles were more stable, although the influent was outside of the variability guideline at the surface. The velocity profiling data are illustrated in Figure 5-4 and Figure 5-5. These show the average of the horizontal measurements for each depth location (with the channel floor as the zero datum). The average profiles for the three measurement locations are shown, as is the mean theoretical velocity (flow/area) and the +/- 20% band about the theoretical velocity. A key observation that can be made from these data is that the hydraulic conditions represent a ‘worse’ case when compared to minimum full-scale commissioning requirements. As such, the biosimetry performance data can be considered conservative.

Note that the maximum flow tested for velocity profiling (561 gpm, or 0.8 mgd) was less than the maximum flow used for the biosimetric tests (866gpm, or 1.25 mgd). The biosimetric flow rate was imposed to test low T1 RED points that were needed for developing an RED algorithm. In some applications, protocols may not allow for designing at flows where

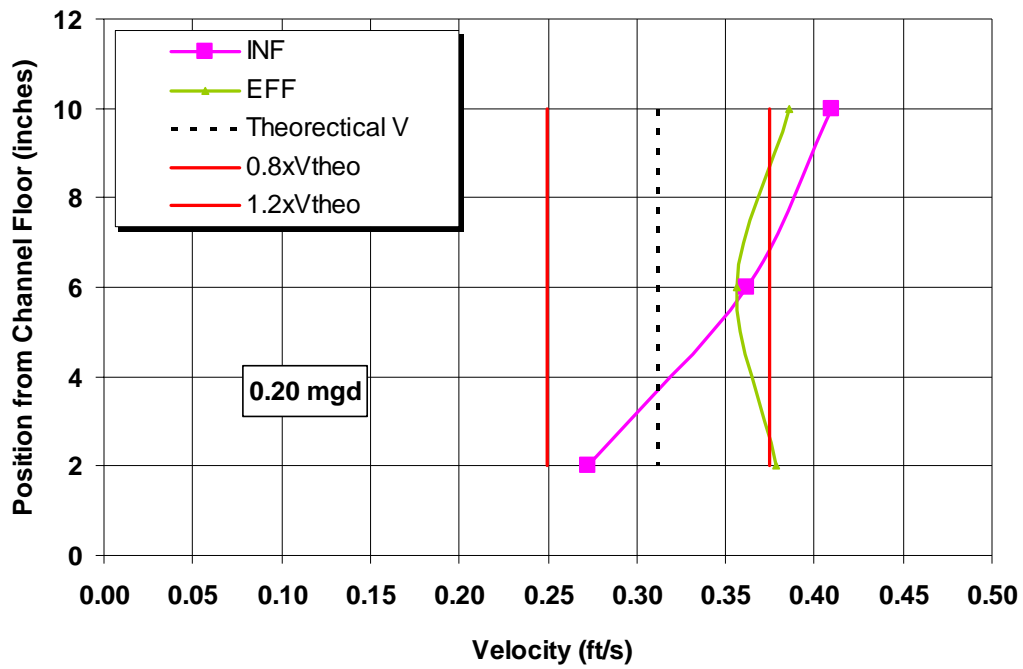

Figure 5-4. Velocity profile at 0.2 mgd.

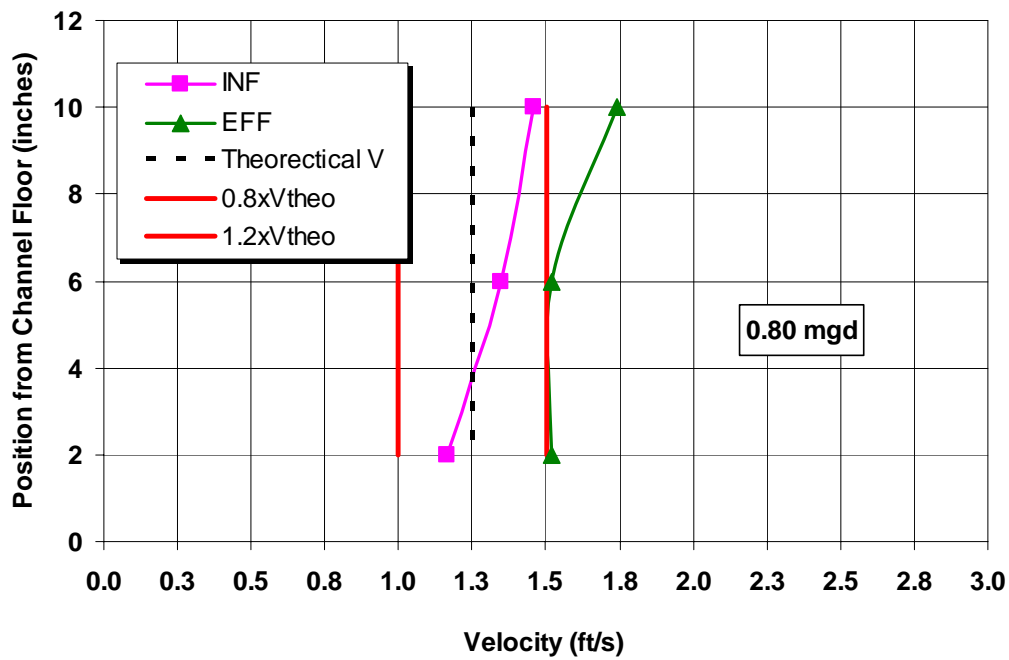

Figure 5-5. Velocity profile at 0.8 mgd.

the flow exceeds the maximum used for velocity profiles. In many cases, however, it is acceptable.

5.2 BACTERIOPHAGE DOSE-RESPONSE CALIBRATION CURVES

5.2.1 Dose-Response Results

Biodosimetric testing for the H-4XE-HO (2W-1B-1C) system was carried out on four different dates in the period September 2008 through October 2008. A seeded influent sample from each day was used to develop the dose-response relationship for samples collected that day. All dose-response tests conducted during this ETV were in compliance with the UVDGM and NWRI/AwwaRF protocols. Calculations follow UVDGM protocols. All raw data are included in Appendix C.

Data from the dose-response tests conducted on the three bacteriophages used during this ETV program are summarized in Table 5-3. The delivered doses presented in the table are calculated using the recommended equation in the UVDGM, as described in Section 4.3.2. The N_0 used for computing the inactivation was estimated by regression analysis of the log of the titers of all dosed and undosed samples versus applied dose, and taking the y-intercept predicted by a second-order regression equation (UVDGM, November 2006). This results in a N_0 value for each dose-response series. Figure 5-6 shows an example of the regression analysis used to determine N_0 ; in this case, MS2 dose-response data are used

5.2.2 Dose-Response Calibration Curve

Once the N_0 for each dose-response series was determined, and the associated log inactivation ($\log N_0/N$) at each dose, regression analyses were conducted in the form of a two-variable second-order equation to yield a dose-response curve in the form:

$$\text{UV Dose} = A \times \left(\log \frac{N_0}{N}\right)^2 + B \times \log\left(\frac{N_0}{N}\right)$$

Figure 5-7 presents the regression analysis for 9/25/08 as an example, based on the calculated N_0 and the observed $\log(N/N_0)$. The 95%-confidence interval is shown, as are the MS2 QA boundaries suggested by the UVDGM (November 2006). Each of the three MS2 collimated beam dose-response series are presented in Figure 5-8. As shown, all MS2 dose-response data generated during the validation test fell within these UVDGM QA bounds.

Table 5-3. Dose-Response Data

Dose Run	Dose (mJ/cm ²)	Log(N)	Inact ¹ Log(N ₀ /N)	Dose Run	Dose (mJ/cm ²)	Log(N)	Inact ¹ Log(N ₀ /N)
MS2							
N₀ = 6.12				N₀ = 6.63			
DR1 (09/11/08) 80.0 UVT	0.0 10.0 20.1	6.15 5.61 5.11	-0.03 0.51 1.01	DR1 (09/25/08) 45.1 UVT	0.0 10.0 20.2	6.63 6.11 5.60	-0.01 0.52 1.03
	30.0 40.0 60.0 80.4 101.2	4.77 4.18 3.25 2.53 1.75	1.36 1.94 2.88 3.59 4.38		30.4 40.5 60.3 81.0 103.8	5.12 4.73 3.81 2.80 2.09	1.50 1.90 2.81 3.82 4.54
DR2 (09/11/08) 80.0 UVT	0.0 10.0 19.9	6.13 5.57 5.08	-0.01 0.55 1.04	DR2 (09/25/08) 45.1 UVT	0.0 9.8 19.7	6.57 6.12 5.58	0.06 0.51 1.05
	30.0 40.0 59.8 80.0 100.7	4.71 4.22 3.46 2.50 1.87	1.41 1.90 2.67 3.62 4.25		29.8 39.6 58.9 79.3 101.6	5.13 4.71 4.02 3.07 2.07	1.50 1.92 2.61 3.56 4.55
DR3 (09/11/08) 80.0 UVT	0.0 10.0 20.1	6.16 5.69 5.09	-0.04 0.43 1.03	DR3 (09/25/08) 45.1 UVT	0.0 10.0 20.1	6.81 6.12 5.55	-0.18 0.50 1.08
	30.0 40.1 59.9 80.2 100.9	4.78 4.21 3.57 2.82 1.87	1.35 1.91 2.56 3.30 4.25		30.2 40.3 60.0 80.7 103.5	5.09 4.56 3.93 2.85 2.07	1.54 2.06 2.69 3.78 4.56
N₀ = 6.53							
DR1 (09/30/08) 58.7 UVT	0.0 9.9 20.0	6.54 5.95 5.52	0.00 0.58 1.01	DR1 (09/30/08) 58.7 UVT	0.0 10.0 20.0	6.54 5.96 5.47	0.00 0.58 1.06
	40.1 60.0 79.7 102.0 124.3	4.50 3.64 2.96 2.09 1.60	2.04 2.89 3.58 4.45 4.93		40.2 60.1 79.8 102.0 124.3	4.47 3.94 2.96 2.14 1.64	2.06 2.59 3.57 4.39 4.89
DR1 (09/30/08) 58.7 UVT	0.0 9.9 20.1	6.58 6.05 5.54	-0.05 0.48 1.00				
	40.1 60.1 79.7 101.9 124.2	4.59 3.95 2.89 2.14 1.57	1.95 2.58 3.64 4.40 4.96				

1. N₀ determined from regression of N and dose.

Table 5-3. Dose-Response Data (Continued)

Dose Run	Dose (mJ/cm²)	Log(N)	Inact¹ Log(N₀/N)	Dose Run	Dose (mJ/cm²)	Log(N)	Inact¹ Log(N₀/N)
T1							
N₀ = 6.61				N₀ = 6.84			
DR1	0.0	6.74	-0.12	DR1	0.0	6.65	-0.03
(09/25/08)	2.5	6.00	0.62	(09/25/08)	2.5	6.01	0.60
44.6 UVT	5.0	5.52	1.10	44.6 UVT	5.0	5.70	0.92
	10.0	4.54	2.08		10.0	4.70	1.91
	15.2	3.51	3.10		15.1	3.72	2.89
	20.0	2.63	3.98		20.0	2.65	3.96
	25.3	1.54	5.08		25.4	1.62	5.00
DR1	0.0	6.71	-0.09				
(09/25/08)	2.5	5.98	0.63				
44.6 UVT	5.0	5.50	1.12				
	9.9	4.57	2.04				
	14.9	3.61	3.01				
	19.8	2.49	4.12				
	24.9	1.58	5.04				

1. N₀ determined from regression of N and dose.

Table 5-3. Dose-Response Data (Continued)

Dose Run	Dose (mJ/cm ²)	Log(N)	Inact ¹ Log(N ₀ /N)	Dose Run	Dose (mJ/cm ²)	Log(N)	Inact ¹ Log(N ₀ /N)
Qβ							
N₀ = 6.11				N₀ = 6.17			
DR1	0.0	6.15	-0.04	DR1	0.0	6.09	0.07
(10/07/08)	4.9	5.61	0.49	(10/07/08)	5.0	5.63	0.54
45.5 UVT	10.1	5.12	0.99	73.4 UVT	10.0	5.16	1.01
	19.9	4.37	1.74		20.0	4.39	1.78
	30.1	3.51	2.60		30.1	3.49	2.67
	39.8	2.60	3.51		40.1	2.54	3.63
	61.0	1.22	4.89		60.6	1.11	5.06
DR2	0.0	6.15	-0.04	DR2	0.0	6.17	-0.01
(10/07/08)	5.1	5.52	0.59	(10/07/08)	4.9	5.60	0.56
45.5 UVT	10.1	5.18	0.92	73.4 UVT	9.9	5.22	0.95
	20.2	4.27	1.84		19.9	4.41	1.76
	30.4	3.49	2.62		29.9	3.51	2.66
	40.3	2.51	3.60		39.7	2.60	3.57
	61.8	1.20	4.90		60.2	1.27	4.90
DR3	0.0	6.11	0.00	DR3	0.0	6.17	0.00
(10/07/08)	4.9	5.57	0.54	(10/07/08)	5.0	5.79	0.38
45.5 UVT	10.0	5.17	0.93	73.4 UVT	10.1	5.27	0.90
	19.9	4.31	1.80		20.1	4.39	1.78
	29.9	3.49	2.61		30.3	3.52	2.65
	39.7	2.56	3.55		40.3	2.47	3.70
	60.9	1.13	4.98		61.0	1.34	4.83

1. N₀ determined from regression of N and dose.

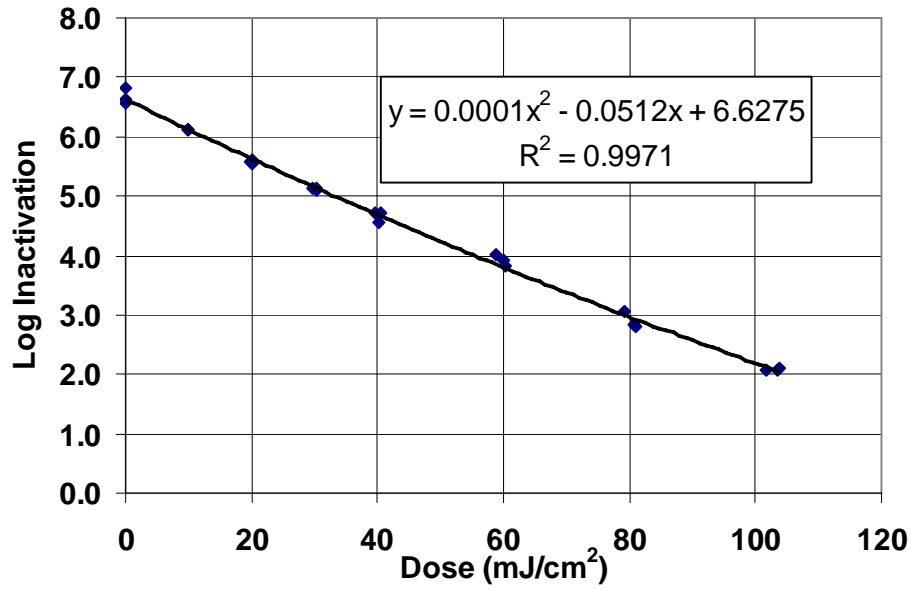

Figure 5-6. An Example of N_0 determination (09/25/08 Dose-Response Data)

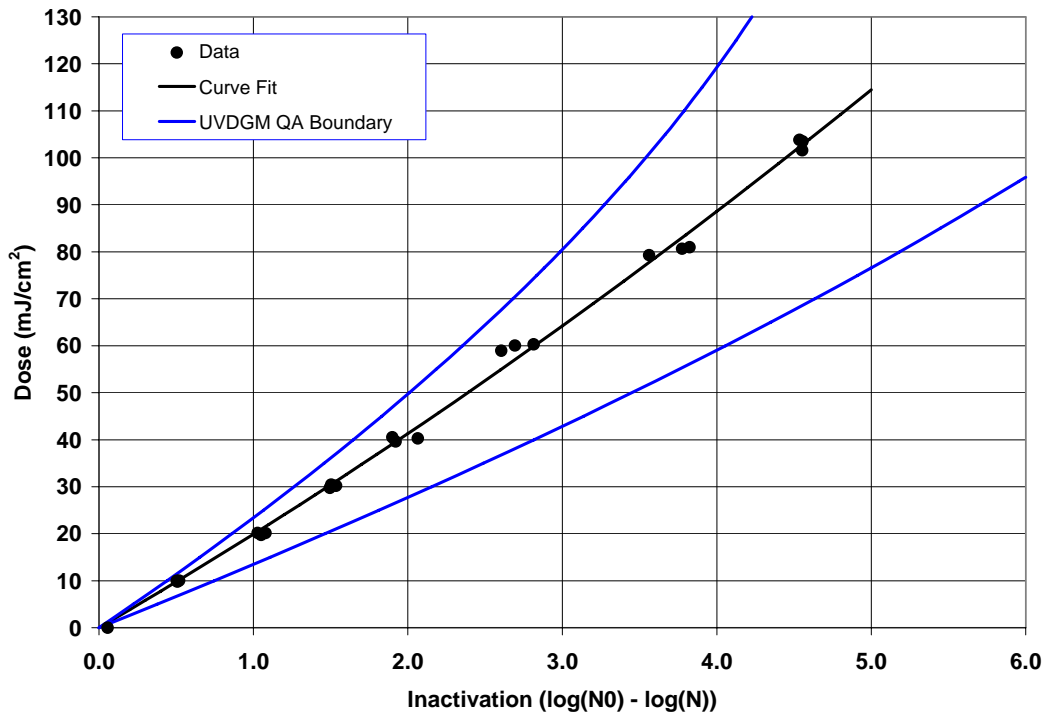

Figure 5-7. An example of a Dose-Response regression analysis for MS2 (09/25/08, UVT =45.1%).

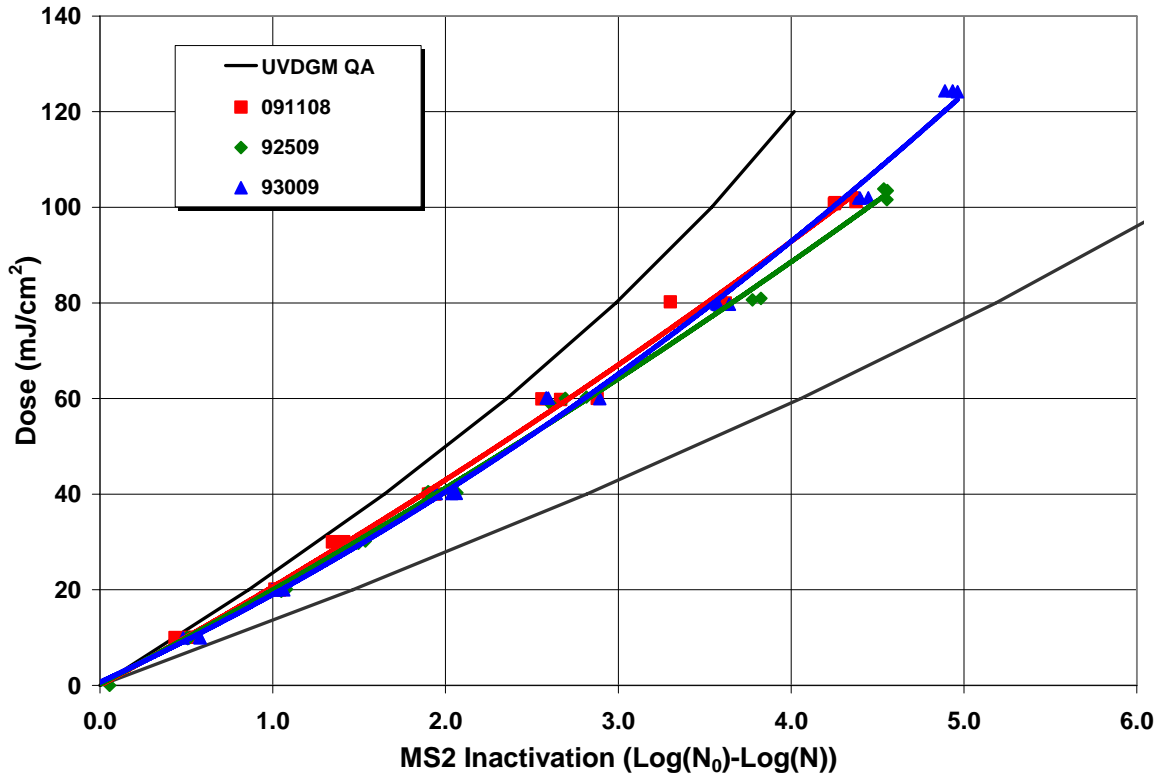

Figure 5-8. MS2 Dose-Response calibration curves.

Figure 5-9 and Figure 5-10 present the dose-response data developed for T1 and Q β coliphage. The UVDGM does not provide QA bounds for T1 or Q β , as it does for MS2. Instead, as described in the VTP, past dose-response data developed by HydroQual’s laboratory, outside of this ETV, were compiled and analyzed to define their 95%-confidence limits, which were then used to assess the data generated within the project. As shown in Figure 5-11, the behavior exhibited by the T1 coliphage was consistent with current practice. In the case of Q β , all but the highest dose data fell within the QA bounds (Figure 5-10). This may be because the phage stock used for this ETV contained less particulate, allowing for a more linear behavior at the higher dose levels. It may also be an artifact of the very limited data set used to develop the confidence bounds.

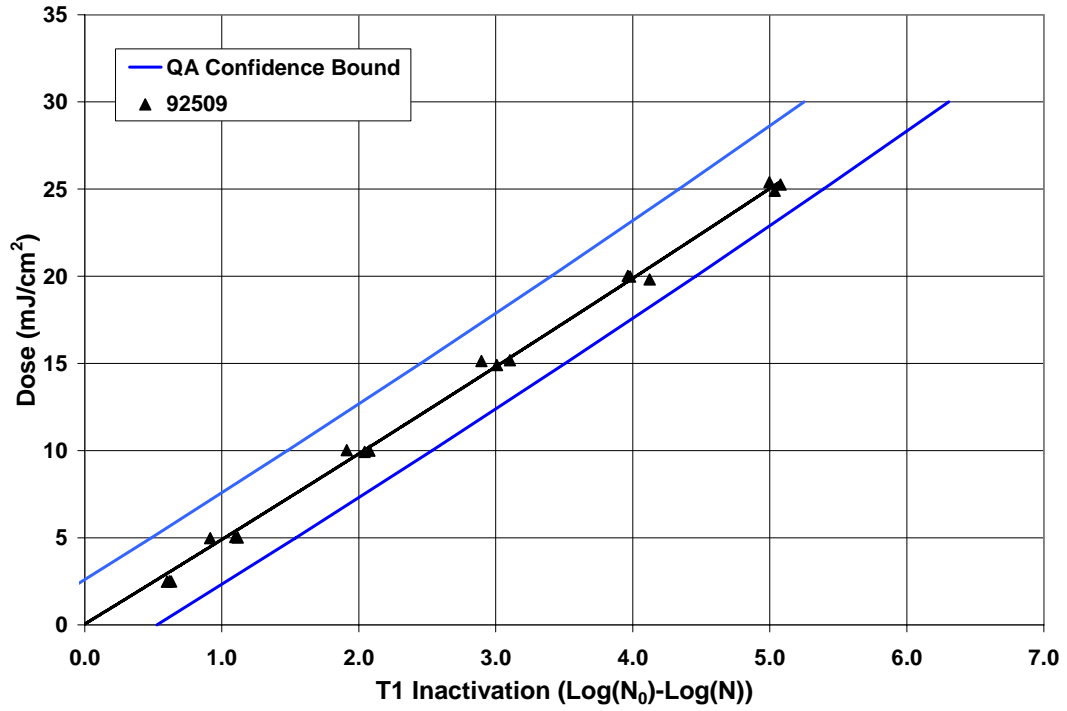

Figure 5-9. T1 Dose-Response calibration curves.

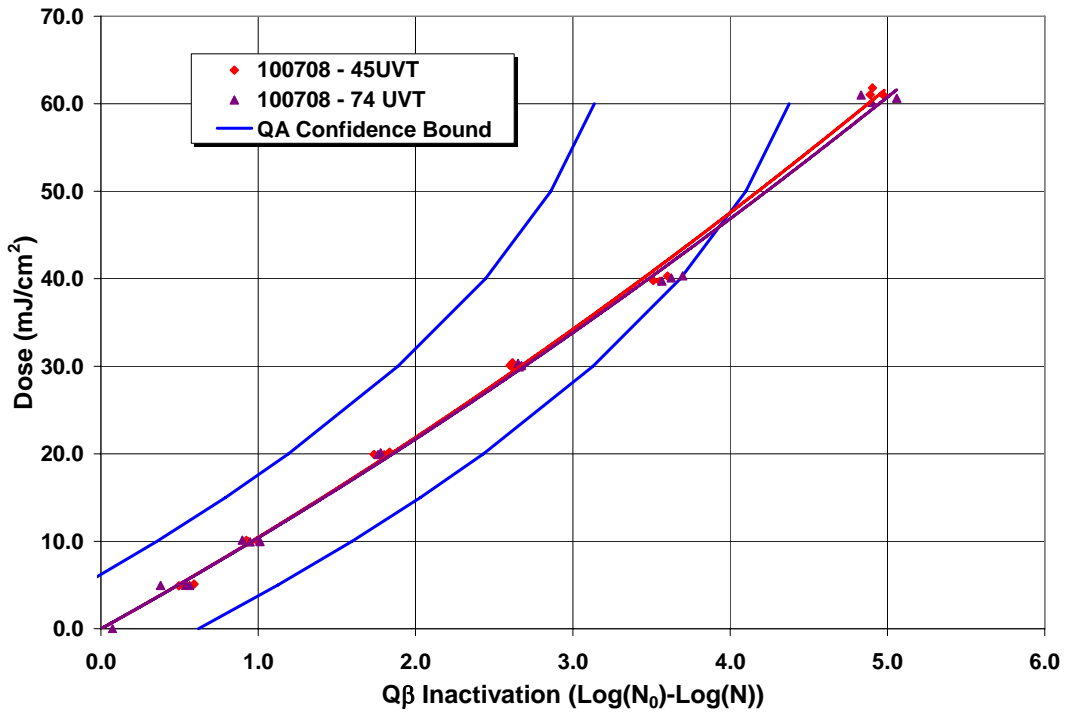

Figure 5-10. Qβ Dose-Response calibration curves.

The dose-response regression equation parameters for each day are summarized in Table 5-4. These equations were then used to compute the reduction equivalent dose (RED) for the field tests collected on their respective days. The residuals resulting from a comparison of the curve fit prediction with the actual data show no significant trend, supporting the validity of the curve fit model. An example of the residuals analysis, from the 9/25/08 MS2 data, is shown on Figure 5-11.

Table 5-4. Summary of Dose-Response Curve Regression Parameters

DR Date	Coliphage	A	B	R ²
09/11/08	MS2	0.8550	19.790	0.9962
09/25/08	MS2	0.7471	19.162	0.9972
09/25/08	T1	0.03143	4.847	0.9974
09/30/08	MS2	1.484	17.306	0.9965
10/07/08	Qβ-45UVT	0.4763	9.9807	0.9980
10/07/08	Qβ-74UVT	0.4374	9.9642	0.9968

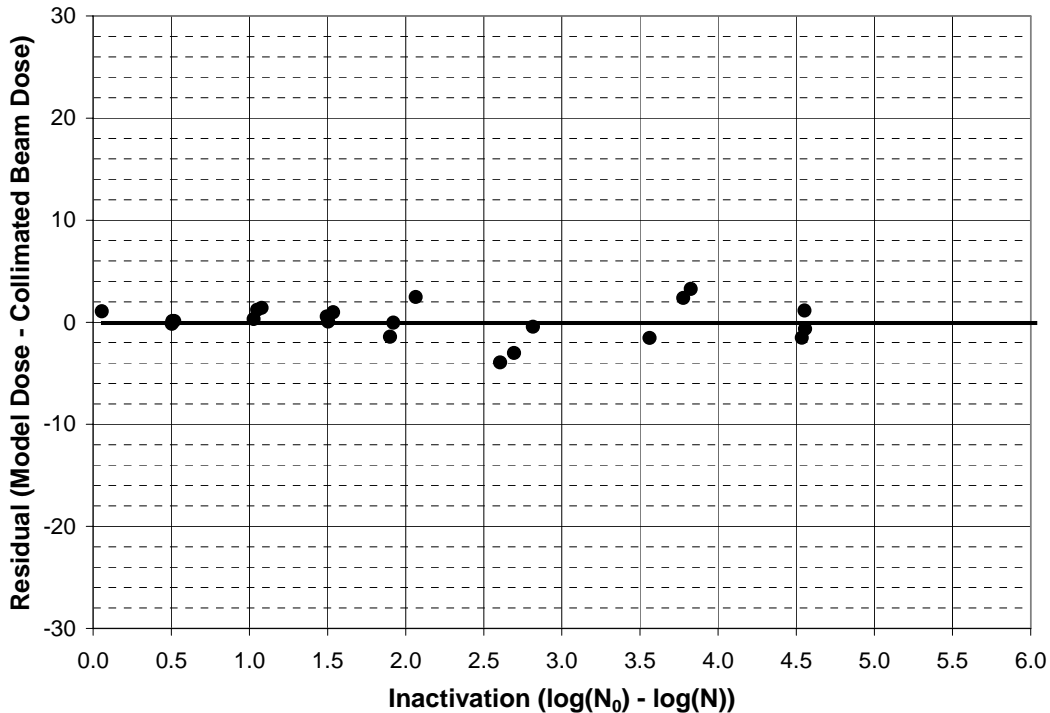

Figure 5-11. Example of Dose-Response curve-fit residuals analysis (09/25/08 MS2 data).

5.2.3 Collimated Beam Uncertainty

Specific QA guidance is provided in the protocols for the dose-response collimated beam tests. Its uncertainty is considered a component of the validation factor, as discussed in a later section. Using the guidance provided by the UVDGM, the uncertainty of the dose-response relationship, U_{DR} , is assessed. A standard statistical method described in Draper and Smith (1998) was followed to determine U_{DR} , expressed as a percentage of the dose response at a particular log inactivation:

$$U_{DR} = 100 \times \frac{t_{stat}}{Dose_{Calc-0}} \times \sqrt{\frac{1}{n} + \frac{[Log_Inact_0 - Mean(Log_Inact)]^2}{\sum_{i=1}^n [Log_Inact_i - Mean(Log_Inact)]^2}} \times \sqrt{\frac{\sum_{i=1}^n (Dose_{DR-i} - Dose_{Calc-i})^2}{n-2}}$$

Where:

- n = Number of dose-response data points, unitless
- Log_Inact_i = Biological log inactivation at each dose point, unitless
- Log_Inact₀ = Particular biological log inactivation rate, *e.g.*, 1.0, unitless
- Mean (LogInact) = Average of all dose-response “Log_Inact_i” values, unitless
- Dose_{DR-i} = Dose applied for each response point, mJ/cm²
- Dose_{Calc-i} = Calculated dose using dose-response curve for each inactivation point, mJ/cm²
- Dose_{Calc-0} = Calculated dose using dose-response curve for Log_Inact₀, mJ/cm²
- t_stat = The t statistic of the dose-response data population at 95% confidence level

The U_{DR} for all dose-response series in this validation is presented in Figure 5-12 as a function of the phage log-inactivation. Using guidance provided by accepted protocols, including the UVDGM, the U_{DR} , computed at the 95%-confidence level, should not exceed 15% at the UV dose corresponding to 1-Log inactivation. As shown in Figure 5-12, this criterion is met, which means that the U_{DR} does not have to be included in the validation factor.

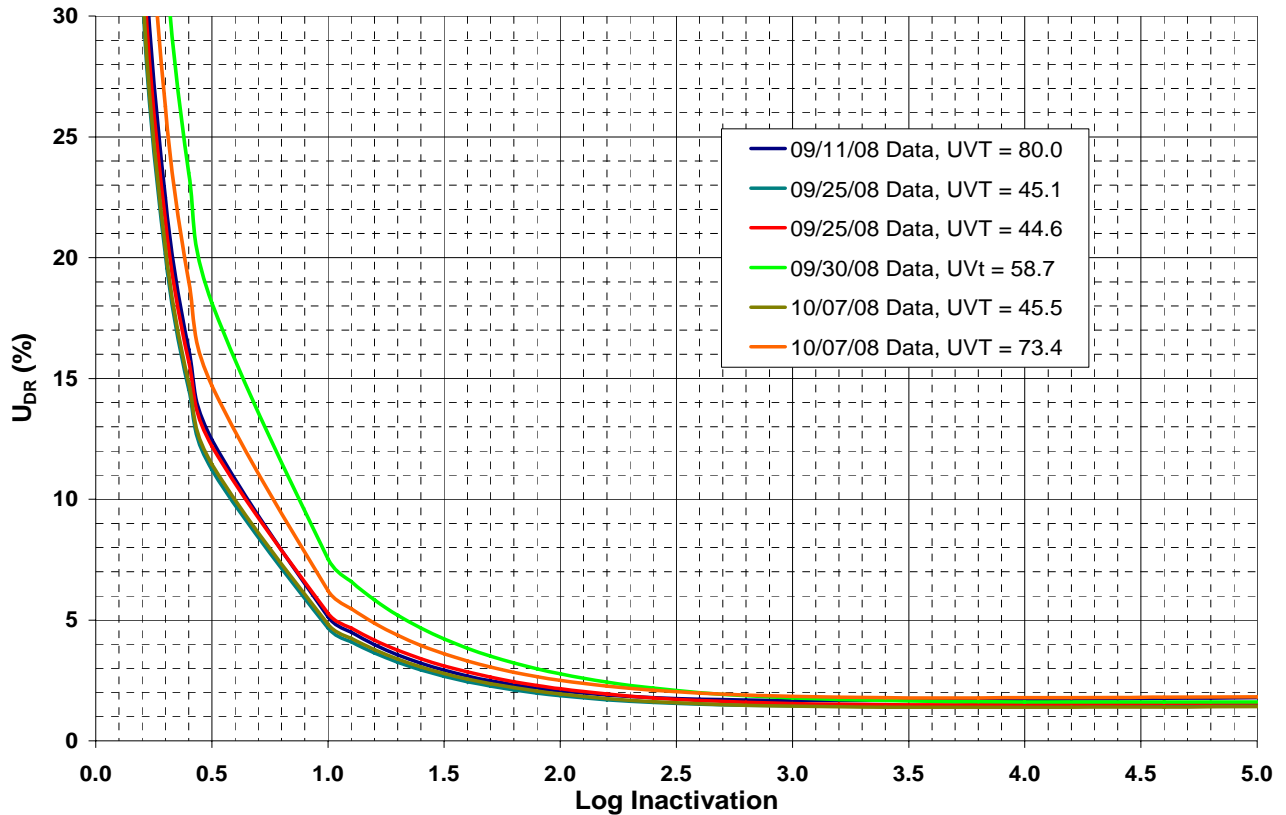

Figure 5-12. Dose-Response curve-fit uncertainty (U_{DR}).

5.3 DOSE-FLOW ASSAYS

5.3.1 Intensity Attenuation Factor

Biodosimetric tests were conducted at a simulated total attenuation factor of 80%, representing the combined effects of the end-of-lamp-life (EOLL) factor and the fouling factor. Siemens stated that the PLC power setting of 100 was considered the full or nominal operating input power for the H-4XE-HO (2W-1B-1C) system. As discussed in Section 5.1.3, the total attenuation factor for the Siemens H-4XE-HO (2W-1B-1C) system was simulated by lowering the water transmittance. For testing at the three nominal UVT values, 80%, 65%, and 50%, used for this validation, the actual UVT levels that were used to simulate 80% sensor attenuation were determined by direct measurements. These were determined to be 74.6%, 58.5% and 44.7%, respectively.

5.3.2 Flow Test Data and Results Summary

A total of 31 acceptable flow tests were conducted for this ETV. The results are summarized in Table 5-5, Table 5-6 and Table 5-7. Included are the no-dose flow tests that were conducted with each test organism (Section 6.3.2). All raw data and notes are included in Appendix C.

Water quality was checked for each day of sampling. Raw total residual chlorine was typically between 0.4 and 0.5 mg/L. Dechlorination was performed, yielding total residual chlorine levels always less than 0.05 mg/L (the minimum detection level). Through the full field test period, the turbidity was between 0.33 and 0.66 NTU; water temperatures ranged between 12.5 and 17.1 °C; and pH was between 6.95 and 7.23. These data are provided in Appendix C.3.4.

Tables 5-5 to 5-7 present the average values for the operational parameters and the analytical results for each field test condition (three influent and three effluent samples). The flow is an average of the flow rate during the sampling period. The reported UVT measurement is the average of all three influent samples, and the inactivation represents the log difference between the average of the influent samples and the average of the effluent samples. The reported reduction equivalent dose (RED) is based upon the dose-response curve for the collimated beam data from the same day, as presented in Section 5.2.

The biosimetric RED data are presented as a function of flow (gpm) in Figure 5-13 for each challenge phase at their respective nominal UVT levels. More specific to design sizing considerations, Figure 5-14 presents the same RED data as a function of the flow rate per lamp, which was computed as the observed flow divided by 16 lamps. The bounds described by Figure 5-13 and Figure 5-14 represent the validated operating envelope for the UV system:

Flow:	134 to 866 gpm
Flow/lamp:	8.37 to 54.14 gpm/lamp
UVT:	50 to 80%
Power:	100 at PLC, or 100% input (2.75 kW/16 lamps, or 171 W/lamp)

Table 5-5. MS2 Biosimetry Tests: Delivered RED and Operations Data

PLC Power	S (%)	Actual Power (kW)	%T Actual (%/cm)	Flow (mgd)	Flow (gpm)	Flow per Lamp (gpm/L)	MS2 Inact (N₀-N)	MS2 RED (mJ/cm²)
100	17.0	2.7	45.3	0.50	346	21.60	1.56	31.7
100	17.0	2.7	44.9	0.79	549	34.34	1.33	26.7
100	17.0	2.7	44.8	1.25	866	54.14	0.99	19.8
100	0.0	0	45.1	1.24	864	54.00	0.00	-0.1
100	36.0	2.7	59.1	0.19	134	8.39	4.43	105.9
100	17.0	2.7	45.4	0.19	134	8.37	2.76	59.0
100	78.7	2.7	74.9	0.30	208	13.02	5.92	154.5
100	36.0	2.7	58.8	0.31	212	13.26	3.51	79.0
100	17.3	2.7	45.4	0.30	212	13.23	2.09	42.7
100	79.0	2.7	74.9	0.40	281	17.53	4.75	115.6
100	17.7	2.7	45.9	0.40	280	17.49	1.75	34.8
100	78.3	2.7	74.8	0.50	349	21.81	4.18	98.2
100	36.0	2.7	58.6	0.50	350	21.85	2.53	53.2
100	79.0	2.7	74.8	0.60	420	26.22	3.73	85.2
100	36.0	2.7	58.3	0.60	414	25.88	2.20	45.4
100	79.0	2.7	74.8	0.70	484	30.28	3.35	74.7
100	36.0	2.7	58.5	0.80	552	34.52	1.60	31.6

Table 5-6. T1 Biosimetry Tests: Delivered RED and Operations Data

PLC Power	S1 (%)	Actual Power (kW)	%T Actual (%/cm)	Flow (mgd)	Flow (gpm)	Flow per Lamp (gpm/L)	T1 Inact (N₀-N)	T1 RED (mJ/cm²)
100	16.3	2.7	44.6	0.60	415	25.93	3.47	17.2
100	17.0	2.7	44.9	0.79	549	34.34	2.73	13.5
100	17.0	2.7	45.1	0.99	689	43.04	2.54	12.5
100	17.0	2.7	44.8	1.25	866	54.14	2.12	10.4
100	0.0	0.0	45.1	1.24	864	54.00	-0.01	0.0

Table 5-7. Q β Biosimetry Tests: Delivered RED and Operations Data

PLC Power	S1 (%)	Actual Power (kW)	%T Actual (%/cm)	Flow (mgd)	Flow (gpm)	Flow per Lamp (gpm/L)	Q β Inact (N ₀ -N)	Q β RED (mJ/cm ²)
100	17.0	2.8	44.0	0.30	205	12.84	2.84	31.8
100	17.0	2.8	44.6	0.40	277	17.30	2.37	26.1
100	17.0	2.8	43.7	0.50	344	21.48	2.06	22.4
100	36.0	2.8	57.8	0.49	340	21.27	3.68	42.6
100	36.0	2.8	57.8	0.60	414	25.85	3.28	37.3
100	78.0	2.8	73.8	0.70	483	30.18	4.81	58.0
100	36.0	2.8	57.5	0.79	548	34.24	2.67	29.7
100	16.7	2.8	43.6	0.79	551	34.45	1.58	16.9
100	0.0	0.0	74.3	0.79	547	34.19	-0.1	-0.1

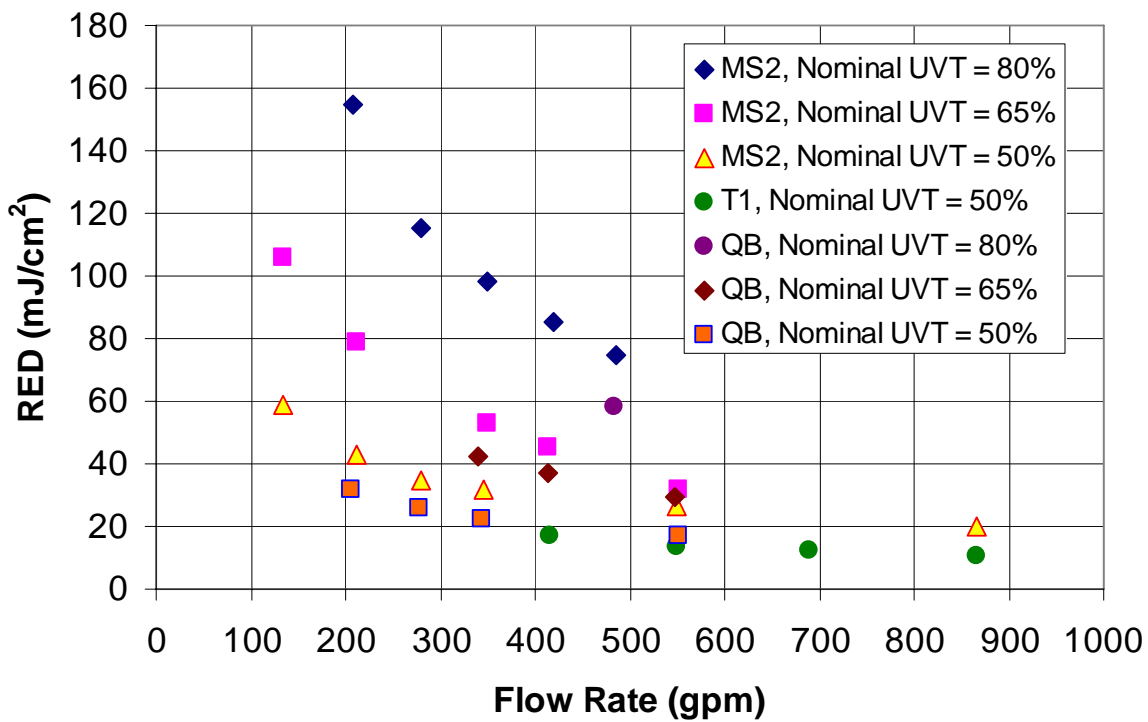

Figure 5-13. MS2, T1 and Q β RED as a function of UVT and flow.

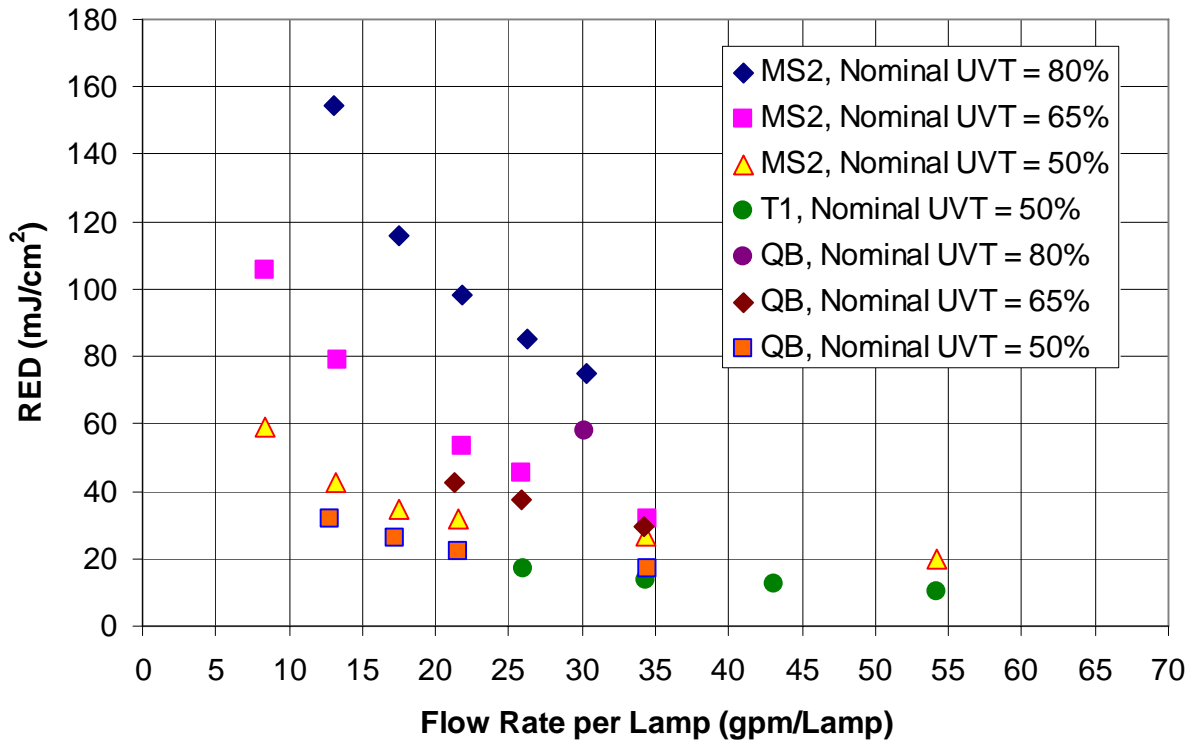

Figure 5-14. MS2, T1 and Qβ RED as a function of UVT and flow/lamp.

5.3.3 Biodosimetric Data Analysis – RED Algorithm

A dose algorithm was developed to correlate the observed MS2, T1 and Qβ RED data with the reactor’s primary operating variables. These are the hydraulic loading rate, as defined by the flow rate per lamp, Q/L, and sensor reading, S, which reflects the quality of the water (UVT) and the output of the lamp. These variables are known on a real-time basis by the PLC and can be programmed into software to monitor and control the UV system.

Because multiple surrogates were used to test the system, it is possible to combine the test results and incorporate the sensitivity of each in order to differentiate their individual reactions at the specified operating conditions. The commissioned system can then incorporate the sensitivity of the targeted pathogen (e.g., total or fecal coliform, enterococcus, etc.) when calculating the RED delivered by the system. In this context, it is important that the targeted pathogen (or pathogen indicator) have a UV sensitivity that is within the bounds of those tested.

The three replicates from each operating condition were treated as individual test points for the dose algorithm development. The dose algorithm to estimate the RED is expressed as:

$$RED = 10^a \cdot (Q / L)^b \cdot S^c \cdot UVS^d$$

Where:

Q = Flow rate, gpm

L = Number of lamps

S = Sensor Reading (%)

UVS = UV Sensitivity (mJ/cm²/Log Inactivation)

a, b, c, d = Equation coefficients

Note that the same sensor and its installed conditions, such as model type, position relative to the lamp, sleeve clarity, etc., must be used to apply this algorithm (see Section 5.3.4). This algorithm is valid if sensor readings are confirmed to meet the modeled results as a function of UVT and power setting.

Based on a multiple linear regression analysis in the form of this RED equation, the coefficients were determined and are summarized in Table 5-9. The algorithm-calculated REDs versus the observed MS2, T1 and Qβ REDs are plotted in Figure 5-15, wherein good agreement is noted between the predicted and observed RED. This comparison is used in Section 7 to assess the uncertainty associated with the experimental methods used to generate the RED data.

Table 5-8. H-4XE-HO (2W-1B-1C) Dose-Algorithm Regression Constants

Coefficient	Value
a	0.950550
b	-0.609884
c	0.683241
d	0.398391

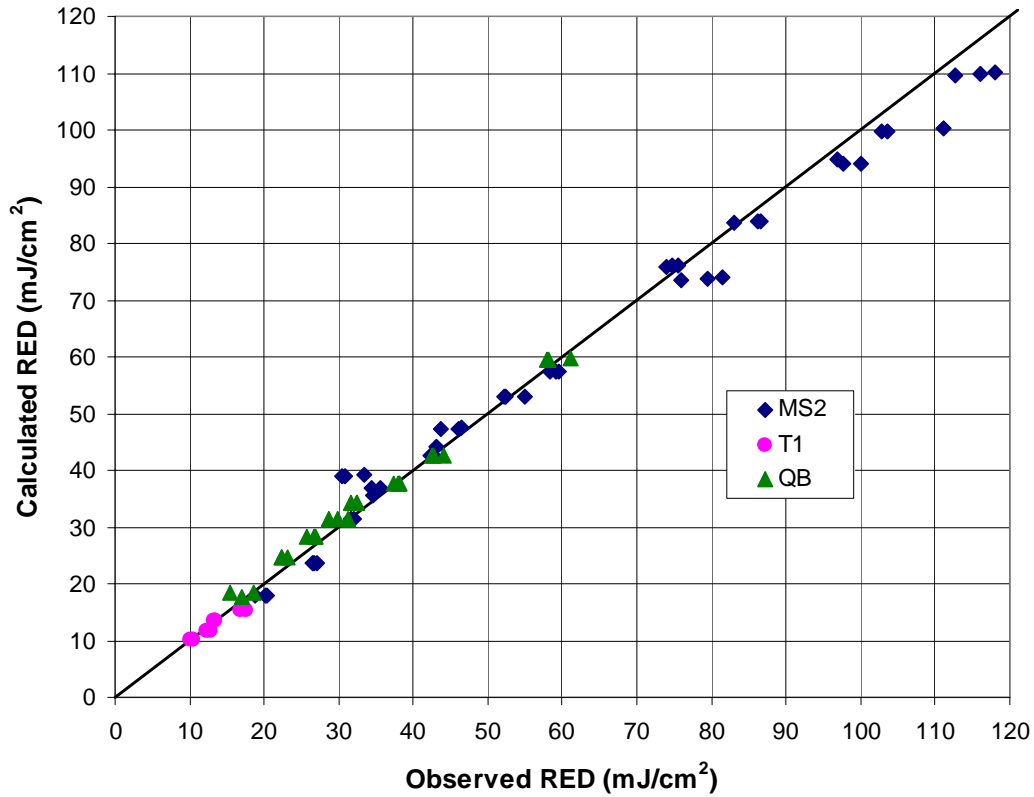

Figure 5-15. Algorithm-Calculated RED versus Observed RED.

5.3.4 Sensor Model

The calculated RED results displayed in Figure 5-14 are based on the actual sensor readings. When commissioned, it will be necessary to assure that the same sensor position is maintained and the same readings are obtained at given operating conditions. To assist with this objective, sensor measurements were analyzed and a sensor model developed to allow prediction of the sensor reading in a commissioned system. This is written:

$$S = 0.000082645 (\text{UVT254})^{3.169}$$

Where:

S = Sensor reading (%)

UVT254 = UV transmittance at 254nm (%/cm)

Figure 5-16 presents the model predictions as a function of the UVT. These data are at a power setting, P, of 100, which is the normal operating condition for the H-4XE-HO (2W-1B-1C). As shown, there is good agreement, providing a tool to assess the sensor position and function for a commissioned system.

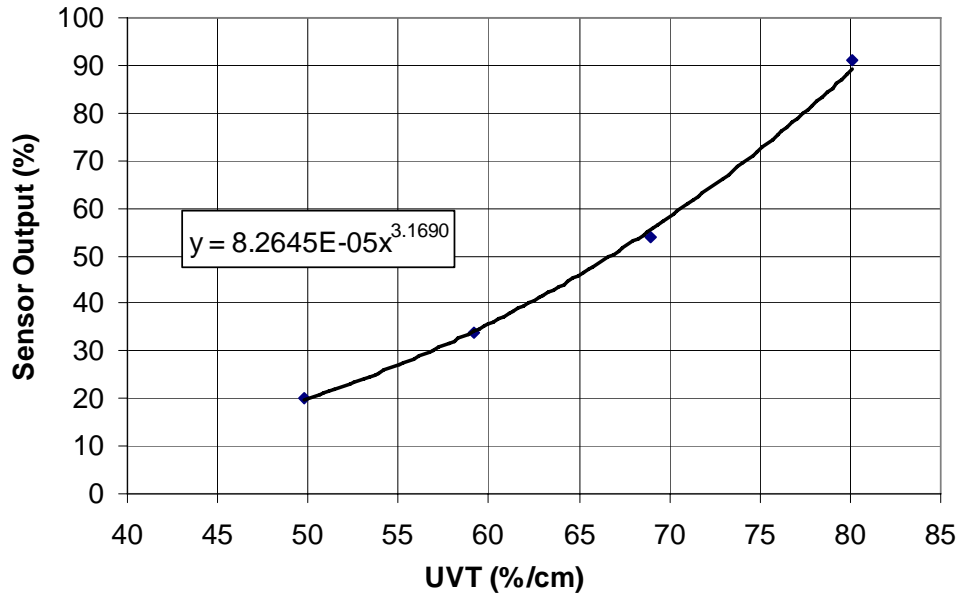

Figure 5-16. Sensor model prediction as a function of UVT.

SECTION 6

QUALITY ASSURANCE/QUALITY CONTROL

6.1 CALIBRATIONS

6.1.1 Flow Meter Calibration

The 12-in. flow meter installed at the UV Center is periodically checked for accuracy by measuring the change in level over time while pumping into an accurately measured tank, using a depth gauge with a resolution of 0.01 ft. The actual flow rate was determined by dividing the volume change in the tank by the change in time and then comparing it to the average meter flow reading recorded over the same interval. Several such calibration runs have been conducted spanning the range of flows normally applied on the 12-in. test stand, and are summarized in Table 6-1. There is good agreement between the flow meter reading and the flow rate calculated by water level change. Raw data are included in Appendix C.

Table 6-1. 12-in. Flow Meter Calibration

Date	Actual Flow Drawdown (gpm)	Flow meter Reading (gpm)	Corrected Flow (gpm)	Difference (%)
10/30/07	132	153	151	-12.6
10/30/07	724	706	700	3.8
10/30/07	1478	1401	1388	6.7
10/30/07	2739	2798	2771	-1.0
11/21/07	3540	3507	3474	2.1
11/21/07	5197	5295	5245	-0.7
04/01/08	499	512	507	-1.4
04/01/08	1384	1423	1410	-1.6
5/15/08	1217	1231	1219	0.0
5/15/08	830	848	840	-1.1
5/15/08	559	585	579	-3.3
5/15/08	293	296	293	0.3
5/15/08	101	105	103	-1.9
11/12/08	1577	1655	1636	-3.6
11/12/08	479	495	489	-2.2
11/12/08	51	50	49	4.0
Average Difference (%)				-0.77

Based upon these calibrations, small corrections were applied to the metered flow-rate data acquired during the validation work. Except where explicitly stated, all of the reported flow-rate data represent this calibrated flow rate. Table 6-1 shows the “curve-fit flow” that is predicted by the meter flow and the percent difference with the actual flow. The calibration data are plotted in Figure 6-1 with the linear correction formula shown in units of gpm. The mean residual is 0.8% for the meter across the range of flow rates.

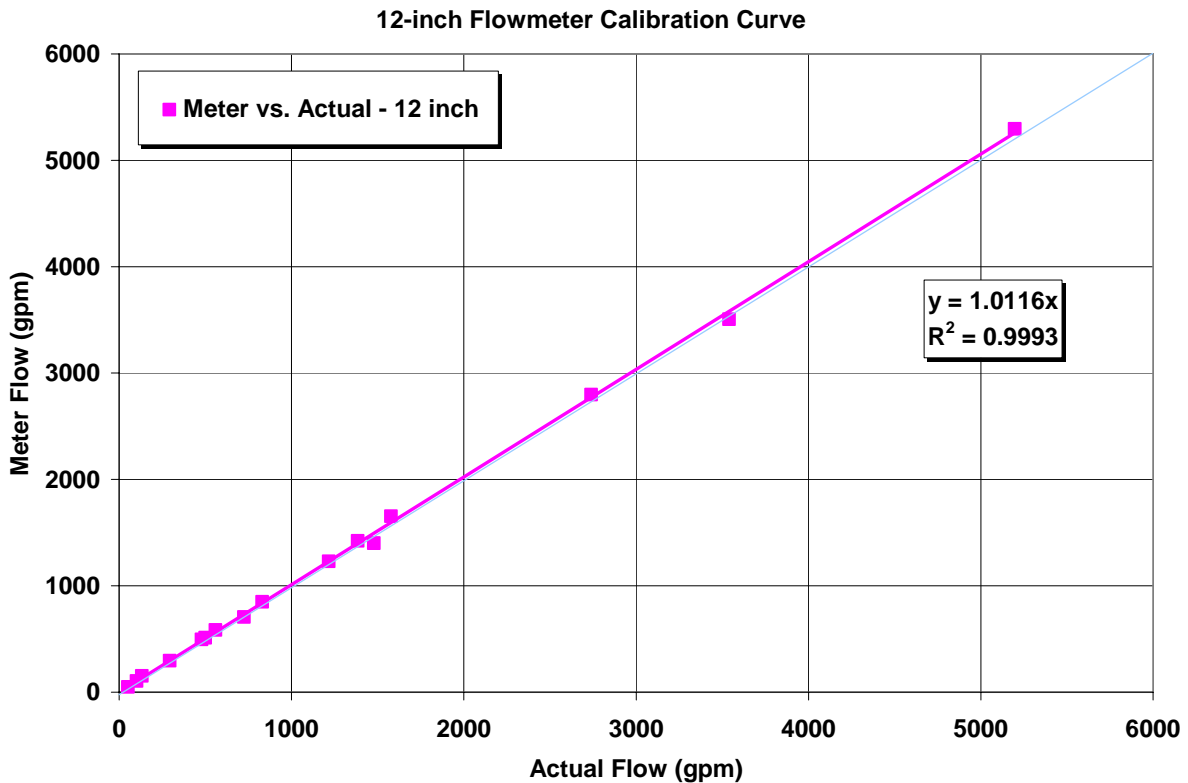

Figure 6-1. 12-in. flow meter calibration data and correction formula.

6.1.2 Spectrophotometer Calibration

Transmittance measurements were made with a GenTech Model 1901 Double Beam UV/Vis Spectrophotometer. Calibrations were conducted before and after validation testing, and periodically during testing with a NIST-traceable Holmium Oxide cell for wavelength calibration (RM-HL S/N 6143), and a NIST-traceable Potassium Dichromate cell with matched reference for transmittance calibration (RM-02 S/N 5925). One-centimeter path length quartz cells were used. Table 6-2 presents the NIST-traceable data generated during the validation period. In all cases, the calibration checks were well within the protocol guidance of 10% measurement uncertainty.

Table 6-2. Wavelength and Absorbance Checks

09/03/08			
Certified Wavelength		Measured Wavelength	
(nm)		(nm)	
287.66		287.50	
278.23		278.00	
250.16		250.90	
241.24		241.00	
Wavelength	Certified ABS	Measured ABS	Error
(nm)	(ABS/cm)	(ABS/cm)	(%)
235	0.236	0.234	-0.84
257	0.277	0.276	-0.36
313	0.093	0.092	-1.08
350	0.208	0.206	-0.96
09/15/08			
Certified Wavelength		Measured Wavelength	
(nm)		(nm)	
287.66		287.40	
278.23		278.00	
250.16		249.90	
241.24		241.00	
Wavelength	Certified ABS	Measured ABS	Error
(nm)	(ABS/cm)	(ABS/cm)	(%)
235	0.236	0.235	-0.42
257	0.277	0.276	-0.36
313	0.093	0.092	-1.08
350	0.208	0.206	-0.96
09/22/08			
Certified Wavelength		Measured Wavelength	
(nm)		(nm)	
287.66		287.40	
278.23		278.00	
250.16		250.00	
241.24		241.00	
Wavelength	Certified ABS	Measured ABS	Error
(nm)	(ABS/cm)	(ABS/cm)	(%)
235	0.236	0.237	0.42
257	0.277	0.277	0.00
313	0.093	0.093	0.00
350	0.208	0.207	0.48

Table 6-2. Wavelength and Absorbance Checks (Continued)

09/30/08			
Certified Wavelength (nm)		Measured Wavelength (nm)	
287.66		287.40	
278.23		278.00	
250.16		250.00	
241.24		241.00	
Wavelength (nm)	Certified ABS (ABS/cm)	Measured ABS (ABS/cm)	Error (%)
235	0.236	0.236	0.00
257	0.277	0.277	0.00
313	0.093	0.093	0.00
350	0.208	0.207	0.48
10/06/08			
Certified Wavelength (nm)		Measured Wavelength (nm)	
287.66		287.40	
278.23		278.00	
250.16		249.80	
241.24		241.00	
Wavelength (nm)	Certified ABS (ABS/cm)	Measured ABS (ABS/cm)	Error (%)
235	0.236	0.237	0.42
257	0.277	0.278	0.36
313	0.093	0.093	0.00
350	0.208	0.208	0.00
10/13/08			
Certified Wavelength (nm)		Measured Wavelength (nm)	
287.66		287.50	
278.23		278.00	
250.16		249.90	
241.24		241.10	
Wavelength (nm)	Certified ABS (ABS/cm)	Measured ABS (ABS/cm)	Error (%)
235	0.236	0.235	-0.42
257	0.277	0.276	-0.36
313	0.093	0.092	-1.08
350	0.208	0.207	-0.48

6.1.3 UV Intensity Sensors

For validation test purposes, accepted protocols require that the duty sensors are within 10% of the average of two reference sensors, and that the two reference sensors should be within 10% of their individual measurements. These data had been summarized in Table 5-2, and show that readings are within the 10% QA limits.

6.1.4 Radiometer Calibration

Dose-response data were generated using IL1700 radiometers with an SED240 detector and 254 filter. Per protocol guidance, the radiometers are regularly factory calibrated to within a measurement uncertainty less than 8%. Certifications are provided for the radiometers in Appendix C. Additionally, two radiometers were used for the collimated beam tests, with the second unit checking the readings of the primary unit. The radiometers should be within 5% of one another or corrective action is required. Table 6-3 summarizes the comparison of the two radiometers. The difference from Radiometer 1 to Radiometer 2 ranged between -0.90% and 0.45%, well within the guidance limits. Moreover, the irradiance measurement dose should not differ by more than 5% before and after UV exposure. According to Table 6-3, the maximum absolute difference is 3.67% before and after exposure. As such, no adjustments are necessary in interpreting the dose-response data within runs.

6.2 QA/QC OF MICROBIAL SAMPLES

QA guidance had been provided in the VTP. The field and laboratory measurements were found to be in general compliance with procedures and results, except as may be noted in the following discussions. One deviation from the VTP was the fact that duplicate plating was carried out for each dilution in each coliphage analysis, whereas triplicate plating was cited in the VTP. This method is accepted within lab standard operating protocols, and had inadvertently been carried forward for the ETV tests. Although a deviation, it is not believed to have any impact on the results of the tests, given the strong agreement observed between duplicate plates and replicate samples. If there was any additional uncertainty caused by having 2 instead of 3 plates, this is accounted for in the overall uncertainty expressed in the Validation Factor (VF). The VF is discussed in Section 7.

6.2.1 Reactor Controls

Influent and effluent samples were taken with the lamps off and with phage injection. The equivalent RED of the difference between the influent and effluent titers should be within the measurement error of the lowest measured RED (cited as less than 3%). Table 6-4 summarizes the results of the “no-dose” control for the H-4XE-HO (2W-1B-1C) system. The absolute difference between the influent and effluent control samples results in an RED of 0.03

mJ/cm² for MS2 phage, 0.01 mJ/cm² for T1 phage and 0.4 mJ/cm² for Q β corresponding to 0.16% and 0.11% and 4.5% of the minimum observed MS2, T1, and Q β RED value, respectively. The control sample for Q β is more than the suggested 3% of the minimum Q β RED; however, the equivalent RED of the Q β control sample corresponds to only -0.04 log in phage titer change. Such a small difference in phage titer is near the error limits of the test itself. With this caution, for purposes of this test series, the no-dose differences for each of the phages are considered within the measurement uncertainty of the phage analysis.

Table 6-3. Comparison of Dual Radiometer Readings for Collimated Beam Measurements

Date Plated	Run No.	Radiometer 1			Percent Difference Initial -- Final	Radiometer 2			Percent Difference Initial -- Final	Percent Difference 1 -- 2	
		Initial (mW/cm ²)	Final (mW/cm ²)	Average (mW/cm ²)		Initial (mW/cm ²)	Final (mW/cm ²)	Average (mW/cm ²)			
9/11/2008	DR1	0.2470	0.2480	0.2475	-0.40	0.2480	0.2490	0.2485	-0.40	-0.40	
UVT = 80.0%	DR2	0.2480	0.2470	0.2475	0.40	0.2490	0.2480	0.2485	0.40	-0.40	
	MS2	DR3	0.2470	0.2470	0.2470	0.00	0.2480	0.2480	0.2480	0.00	-0.40
9/25/2008	DR1	0.2170	0.2200	0.2185	-1.37	0.2200	0.2200	0.2200	0.00	-0.69	
UVT = 45.1%	DR2	0.2260	0.2190	0.2225	3.15	0.2280	0.2220	0.2250	2.67	-1.12	
	MS2	DR3	0.2190	0.2210	0.2220	-0.91	0.2220	0.2230	0.2225	-0.45	-1.14
9/25/2008	DR1	0.2210	0.2210	0.2210	0.00	0.2230	0.2260	0.2245	-1.34	-1.58	
UVT = 44.6%	DR2	0.2210	0.2170	0.2190	1.83	0.2260	0.2200	0.2230	2.69	-1.83	
	T1	DR3	0.2170	0.2200	0.2185	-1.37	0.2200	0.2220	0.2210	-0.90	-1.14
9/30/2008	DR1	0.2330	0.2320	0.2325	0.43	0.2320	0.2310	0.2315	0.43	0.43	
UVT = 58.7%	DR2	0.2320	0.2310	0.2315	0.43	0.2310	0.2300	0.2305	0.43	0.43	
	MS2	DR3	0.2310	0.2300	0.2305	0.43	0.2300	0.2300	0.00	0.22	
10/7/2008	DR1	0.2250	0.2240	0.2245	0.45	0.2250	0.2230	0.2240	0.89	0.22	
UVT = 45.5%	DR2	0.2240	0.2270	0.2255	-1.33	0.2230	0.2270	0.2250	-1.78	0.22	
	Qβ	DR3	0.2270	0.2240	0.2255	1.33	0.2270	0.2240	0.2255	1.33	0.00
10/7/2008	DR1	0.2240	0.2250	0.2245	-0.45	0.2240	0.2240	0.2240	0.00	0.22	
UVT = 73.4%	DR2	0.2250	0.2220	0.2235	1.34	0.2240	0.2220	0.2230	0.90	0.22	
	Qβ	DR3	0.2220	0.2250	0.2235	-1.34	0.2220	0.2250	0.2235	-1.34	0.00

Table 6-4. Reactor Control Sample Summary

Phage	Date	Control RED (mJ/cm ²)	Minimum RED (mJ/cm ²)	Percentage (%)
MS2	10/02/08	0.03	18.9	0.16%
T1	10/02/08	0.01	9.1	0.11%
Qβ	10/07/08	0.4	8.8	4.5%

For each reactor control the effluent samples were compared with the average of the three influent replicates. These data are shown in Table 6-5. The titer differences are well within the range of similarity for identical samples, reflecting that there are no extraneous effects on the survival ratios observed during flow tests.

Table 6-5. Similarity between Replicate Flow Test Samples

Date	Phage	Sample	Avg INF	EFF	Similarity
9/25/2008	MS2	A		6.26E+00	-0.02
		B	6.24E+00	6.26E+00	-0.02
		C		6.21E+00	0.03
9/25/2008	T1	A		6.00E+00	-0.03
		B	5.97E+00	5.98E+00	-0.01
		C		5.97E+00	0.00
10/7/2008	Qβ	A		5.64E+00	-0.07
		B	5.57E+00	5.59E+00	-0.02
		C		5.53E+00	0.04

6.2.2 Reactor Blanks

Reactor blanks are daily influent and effluent samples taken when there is no challenge microorganism injection. Their titer records are summarized in Table 6-6. Several of the blank samples were noted with measurable titers up to 3-log. This is likely due to the leakage of residual materials from the phage injection system, which was not completely disconnected/isolated from the system when the blanks were collected. However, when these levels are compared to the influent titers of 6-log and above, the titer in the blanks is less than 0.1% of the influent titer, and can be considered negligible.

Table 6-6. Summary of Reactor Blank and Trip Control Sample Analyses

Flow Day	Date (Phage)	Phage Trip Control	Est. Diluted Titer	Diff in Log Conc. (%)	Trip Blank (DI Water)	Influent Blank	Effluent Blank
1	09/11/08 (MS2)	1.0E+12	8.3E+11	0.7	0	1.1E+01	3.3E-01
2	09/16/08 (MS2)	1.0E+12	8.9E+11	0.4	0	1.0E+03	1.0E+03
3	9/18/2008 (MS2)	1.0E+12	6.9E+11	1.3	0	1.0E+03	1.0E+03
	9/18/2008 (T1)	1.20E+06	1.00E+06	1.3			
4	9/23/2008 (MS2)	5.0E+11	4.6E+11	0.3	0	7.2E+00	0.0E+00
	9/23/2008 (T1)	7.0E+10	5.7E+10	0.8	0	0.0E+00	0.0E+00
5	9/25/2008 (MS2)	5.0E+11	3.4E+11	1.4	0	1.0E+01	1.4E+01
	9/25/2008 (T1)	5.00E+10	5.58E+10	-0.4			
6	9/30/2008 (MS2)	7.0E+11	6.7E+11	0.1	0	3.3E+02	3.3E+02
7	10/2/2008 (MS2)	6.5E+11	4.4E+11	1.5	0	1.0E+03	1.0E+03
	10/2/2008 (T1)	5.0E+10	4.9E+10	0.1			
8	10/07/08 (Qβ)	1.2E+11	1.3E+11	-0.4	0	1.0E+03	1.4E+01

6.2.3 Trip Controls

Trip Controls are samples collected from the challenge phage stocks during the test days and shipped to the laboratory with the field samples. Any change in the log concentration of the phage stocks should be less than 3 to 5%. The titer of the stock was analyzed before shipment to the UV Center, the feed stock was sampled at the Center and returned to the laboratory. The comparison shown in Table 6-6 shows the measured feed stock measurement, and the initial feed stock measurement calculated with an equivalent dilution. As shown on Table 6-6, the differences range from -0.4% to 1.5%.

Additionally, trip blank controls (DI water) were collected on each testing day and traveled with the samples to assure no contamination happened during the sample shipment. Table 6-6 shows that this QA check is also satisfied.

6.2.4 Flow Test Sample Replicates

Generally, one influent and one effluent sample were plated in replicate on each test day for a total of 11 replicate platings. The similarity of these titers allows a quantitative evaluation of the plating procedure. The titers are compared by calculating the similarity:

$$Similarity = \log \left(\frac{Sample\ Titer\ 1\ (pfu/mL)}{Sample\ Titer\ 2\ (pfu/mL)} \right)$$

The targeted goal is that these samples should be within the analysis error of 0.2 log. Table 6-7 shows the results of the replicate similarity tests. For the 9 samples plated in replicate during this ETV validation, all were within the acceptable limit. The maximum difference was 0.078 log.

Table 6-7. Results from Flow Test Replicates

Date	Flow	Sample	Log Titer	Similarity
9/25/2008	868 gpm; 43% T; 100 P	Influent 1	6.06E+00	- 0.078
		Influent 2	6.14E+00	
	1042 gpm; 43% T; 100 P	Effluent 1	5.97E+00	-0.033
		Effluent 2	6.00E+00	
	347 gpm; 43% T; 100 P	Influent 1	6.07 E+00	-0.072
		Influent 2	6.14 E+00	
9/30/2008	417 gpm; 74% T; 100 P	Influent 1	6.41 E+00	0.012
		Influent 2	6.40 E+00	
	130 gpm; 45% T; 100 P	Influent 1	6.23 E+00	-0.019
		Influent 2	6.25 E+00	
	278 gpm; 74% T; 100 P	Influent 1	6.31 E+00	0.029
		Influent 2	6.29 E+00	
139 gpm; 60%T; 100 P	Effluent 1	1.75 E+00	-0.062	
	Effluent 2	1.81 E+00		
10/7/2008	347 gpm; 59%; 100 P	Influent 1	6.10 E+00	0.027
		Influent 2	6.07 E+00	
	347 gpm; 45.4%; 100 P	Effluent 1	4.07 E+00	0.026
		Effluent 2	4.05 E+00	

6.2.5 Transmittance Replicates

During the ETV each influent sample was analyzed for %T at 254 nm at the laboratory. In 11 cases a sample was analyzed in replicate to determine the repeatability of the transmittance measurement. The samples are compared using the relative percent difference (*RPD*):

$$RPD = \frac{Analysis\ 1 - Analysis\ 2}{Average(Analysis)} \times 100\%$$

Table 6-8 shows the *RPD* of nine transmittance measurements that were replicated. In all cases, the replicate measurements are in agreement within the 0.5% allowed by the test plan.

6.2.6 Method Blanks

Method blanks are used to check the sterilized reagents used for the challenge virus assay procedure. The challenge microorganism concentration in these blanks was always non-detectable, as shown in the bench records in Appendix C.

Table 6-8. Relative Percent Difference for %T Replicates

Date	Flow	UVT 1	UVT 2	RPD
9/11/2008	INF-4A	80.7	80.6	0.12
9/25/2008	INF-3A	45.3	45.3	0.00
9/25/2008	INF-6C	44.9	44.7	0.45
9/30/2008	INF-3C	75.0	74.9	0.13
9/30/2008	INF-7A	45.9	45.9	0.00
9/30/2008	INF-10B	74.9	74.8	0.13
9/30/2008	INF-13C	58.3	58.3	0.00
10/7/2008	INF-13C	43.5	43.5	0.00
10/7/2008	INF-17A	57.4	57.5	-0.17

6.2.7 Stability Samples

Phage stability was checked by comparing the phage concentrations of a sample plated at 24 hr and at 48 hr after collection. Phage log concentrations of these two estimates should not differ more than 5% from each other. Table 6-9 summarizes the stability check results for MS2, T1 and Q β phage. In all cases, the phage concentrations measured at 24 hr and 48 hr did not differ by more than 5%, meeting the criteria.

Table 6-9. Phage Stability Sample Summary

Date	Phage	Sample	UVT	24 hr	48 hr	Diff (%)
9/30/2008	MS2	A	59.1	6.38	6.33	0.74
		B	59.1	6.28	6.37	-1.35
		C	59.0	6.36	6.38	-0.22
10/2/2008	T1	A	96.0	5.74	5.65	1.59
		B	95.9	5.83	5.62	3.58

		C	95.8	5.77	5.61	2.93
10/07/2008	Qβ	A	73.8	6.20	6.26	1.12

6.2.8 Collimated-Beam Apparatus

The protocol addresses the collimated beam dose calculation and recommends an examination of the dose-calculation uncertainty. Uncertainty criteria are suggested for specific terms within the dose calculation. These are summarized in the following discussions, which present the dose term, the recommended criterion and the estimated uncertainty associated with the methods used by HydroQual. As shown, the collimating apparatus used by HydroQual is well within these guidelines:

Depth of Suspension (d): Protocol Requires < 10%

The same Petri dishes are used for holding the test sample, and a constant volume is added to the sample. This enables one to always achieve the same depth of suspension from test to test. The error is estimated to be 3.8%.

Average Incident Irradiance (E_s): Protocol Requires < 8%

This criterion is similar to that of the radiometer uncertainty and associated criteria. The radiometer used was periodically calibrated with an uncertainty <8%. Certifications for the radiometers used by HydroQual are provided in Appendix C.2.

The Protocol recommends that the irradiance measurement should not differ by more than 5% before and after UV exposure. Additionally, it is required that two radiometers are used for the collimated beam tests, with the second unit checking the readings of the primary unit. The radiometers should be within 5% of one another or corrective action is required. As discussed in Section 6.1.4, this criterion is met.

Petri Factor (P_f): Protocol Requires <5%

The Petri factor is established as the ratio of the average of intensity readings taken across the sample surface to the intensity at the center of the surface. The Petri factor is determined using a fixed apparatus, constant grid and dish geometry, and calibrated detectors. At HydroQual, the Petri factor was typically 0.95, with an error of approximately 2.2%.

L/(d+L): Protocol Requires < 1%

The uncertainty of this parameter relates to the measurement of L (distance from lamp centerline to suspension surface) and d (depth of the suspension). At HydroQual, the uncertainty was estimated to be approximately 0.12%.

Time (t): Protocol Requires <5%

A timer/stopwatch is used to measure the time of exposure. The minimum exposure allowed is 30 seconds, although the typical minimum exposure time is 60 seconds. The error estimated for the manually operated shutter at HydroQual is approximately 1.7%.

$(1-10^{-ad})/ad$: UVDGM requires <5%

This term accounts for the absorbance through the depth of the water sample. Absorbance is measured with an estimated uncertainty of 1% at 254 nm.

6.3 DOSE-RESPONSE DATA

All raw data for dose-response analyses are included in Appendix C.

6.3.1 Excluded Data

No dose-response series are excluded from the analysis of this ETV. All dose response series had plaque counts between the QC boundaries of 30 and 300 on the dosed samples.

6.3.2 MS2 Compliance with QC Boundaries

The QC criteria for the acceptance of the MS2 dose-response data is described in the NWRI Verification Protocol (2003) which defines linear boundaries for the data, and requires greater than 80% of the data to fall between the lines. These QC criteria are based on the statistical analysis of MS2 dose-response data from several independent labs. Figure 6-2 shows the linear QC boundaries and the dose-response data for this ETV. Of the 72 data points from the MS2 dose-responses series (one sample from each of 3 days, with triplicate exposures) within the bounds of 20 and 130 mJ/cm², all points (100%) lie within the specified QC boundary lines, meeting the NWRI criterion.

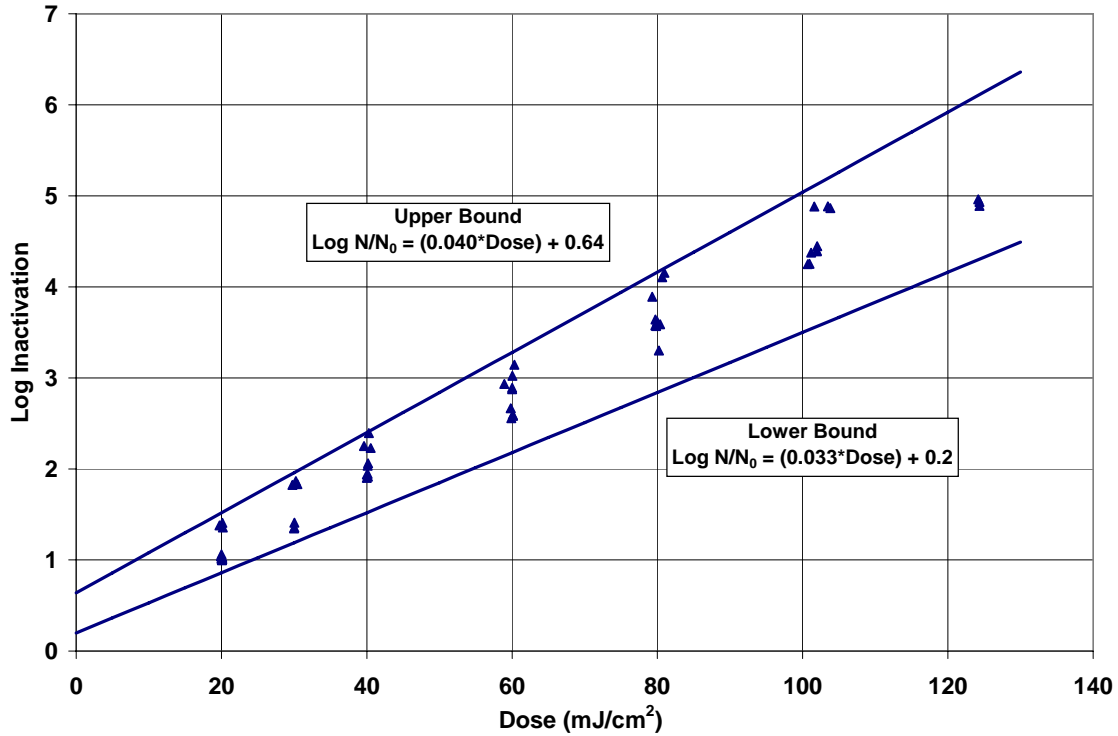

Figure 6-2. Dose-Response data and NWRI QA/QC boundary lines.

Similar bounds are not available from NWRI or other sources for Q β and T1. Refer to Section 5.2.2 for alternate presentations of confidence bounds for each of the three test phages.

6.3.3 Uncertainty in Dose Response

The UVDGM protocols assess the quality of the dose-response data by analyzing the uncertainties at specific applied dose levels. This analysis was presented in Section 5.2.3 and displayed in Figure 5-13. The uncertainties of the dose-response tests (U_{DR}) used to estimate MS2, T1 and Q β RED for the H-4XE-HO (2W-1B-1C) validation were always within the quality control criteria, in that the U_{DR} is less than 15% at 1-log of microbial reduction using standard statistical methods.

SECTION 7

CALCULATION OF THE VALIDATION FACTOR FOR RED AND LOG-INACTIVATION DESIGN SIZING

7.1 DISINFECTION CREDIT IN ACCORDANCE WITH CURRENT PROTOCOLS

The wastewater validation protocols set guidelines to account for potential biases and uncertainties associated with the validation process. Accounting for these uncertainties assures that the design sizing and operation of the installed system will deliver the targeted dose. In order to obtain inactivation credit for UV disinfection, the validated dose of the UV system (D_V) should be equal to or exceed the targeted dose (D_T) for a particular drinking water, wastewater or reuse application, or: $D_V \geq D_T$

7.1.1 Validated Dose (D_V) and Targeted Disinfection

The overall goal of this validation is to assure that dose and log-inactivation targets can be safely applied by the Siemens H-4XE-HO (2W-1B-1C) disinfection system in a manner that is consistent with good design practice. As such, the validation test results described in this report are decremented by specific experimental uncertainties and potential biases to assure that a minimum disinfection performance can be confidently maintained. This adjusted RED is considered the validated dose, which can then be used to determine sizing for specific performance goals.

The validated dose for a UV system, based on the data generated from full-scale field testing, is calculated as:

$$D_V = \frac{RED_{Calc}}{VF}$$

In which:

D_V = Validated dose, in units of mJ/cm^2

RED_{Calc} = Dose calculated using the appropriate RED equation (dose algorithm) and operating conditions. In the case of the H-4XE-HO (2W-1B-1C), the analysis is based on the combined MS2, T1 and Q β RED data.

VF = Validation factor, which quantitatively accounts for certain biases and experimental uncertainties to assure that a minimum disinfection performance level can be confidently maintained.

7.2 DETERMINATION OF THE VALIDATION FACTOR ELEMENTS

The validation factor for the H-4XE-HO (2W-1B-1C) reactor is calculated using the expression:

$$VF = B_{RED} \times B_{poly} \times \left(1 + \frac{U_{Val}}{100} \right)$$

Where:

VF = Validation factor.

B_{RED} = RED bias, a dimensionless correction factor that accounts for the difference between the UV sensitivity of the challenge organism used during the validation tests to a standardized value for any target organism. Evaluation of the B_{RED} is explained in Section 7.2.1 below.

B_{poly} = Polychromatic bias, a correction factor that relates to the UV sensor germicidal wavelength response. For the Siemens H-4XE-HO (2W-1B-1C) system, $B_{poly}=1.0$, as explained in Section 7.2.2 below.

U_{Val} = Experimental uncertainty associated with the validation test.

7.2.1 RED Bias (B_{RED})

The RED Bias relates to the uncertainty when using a challenge organism that is less sensitive to UV than the targeted organism. Reuse applications per current California Title 22 requirements, for example, are based on meeting specific MS2 inactivation and RED goals. These are correlated to targeted viruses. In the case of low-dose secondary effluent applications, total coliform, fecal coliform, enterococcus or *E. coli* are usually targeted. The sensitivities of these classes of microbes are typically similar to the sensitivities of the T1 and Q β used in the validation tests. It is important to note that this assumes use of the linear portion of dose-response curves developed from actual effluent samples. In the presence of particles (as measured by the suspended solids analysis), there is often a tailing effect, attributed to the occlusion of bacteria in the solids and unaffected by UV. One should develop the linear rate for inactivation in order to determine the log-inactivation or RED that can be accomplished by the UV system. The particulate bacterial levels would be considered additive to the residual non-aggregated bacterial densities.

Since this validation used MS2, T1 and Q β for application to a broad dose range, the test microbes can effectively be considered equal or lower in UV sensitivity value (mJ/cm²/LI)

associated with the targeted pathogens. As such, the B_{RED} does not factor into the calculation of the Validation Factor, and can be set to 1.0.

7.2.2 Polychromatic Bias (B_{POLY})

Since the Siemens H-4XE-HO (2W-1B-1C) system uses monochromatic low-pressure lamps, the potential bias associated with polychromatic UV sources is not a factor. B_{POLY} can be set to 1.0 under such conditions.

7.2.3 Validation Uncertainty (U_{Val})

The uncertainty of validation (U_{Val}) in the VF calculation accounts for experimental uncertainties associated with the major experimental variable. U_{Val} has between one and three input variables (described as U_S , U_{DR} and U_{IN} below) based on how well the validation test adhered to recommended QA/QC. The decision tree provided by the validation protocol in Figure 7-1 gives the associated notes for selection of the appropriate equations for calculating U_{Val} .

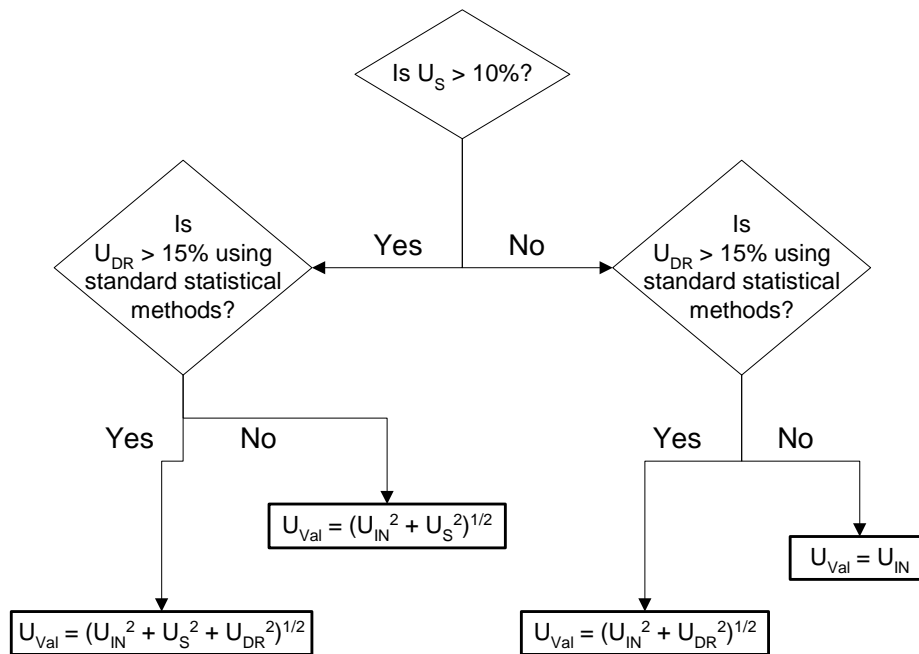

Figure 7-1. U_{Val} decision tree for calculated dose approach.

7.2.3.1 Sensor Measurement Uncertainty (U_S)

The uncertainties associated with the intensity sensor are presented in Table 5-2. The test results showed that the maximum variance observed when comparing the reference sensors to

the average reference sensor reading, and that the maximum variance observed when comparing the duty sensor reading to the average reference sensor reading were both less than 10%. The sensor variance criterion was met (Figure 7-1), and U_S can be ignored when calculating the validation factor.

7.2.3.2 Dose-Response Uncertainty (U_{DR})

With respect to the dose-response uncertainty, the criterion (Figure 7-1) is that the U_{DR} must be less than 15% at an RED level equivalent to 1-log inactivation. This analysis was conducted in Section 5 for all MS2, T1 and Q β dose-response curves generated during the validation. As shown in Figure 5-12, this criterion is met at the 95%-confidence level. As such, the U_{DR} does not have to be included in the validation factor.

7.2.3.3 RED Model Interpolation Uncertainty (U_{IN})

The uncertainty of interpolation, U_{IN} , is evaluated by the following equation:

$$U_{IN} = \left(\frac{t_{stat} \times SD}{RED_{Calc}} \right) \times 100\%$$

In which:

U_{IN} = Uncertainty of interpolation, expressed as a percentage

t_{stat} = t-statistic, retrieved from standard statistics tables (value dependent upon the number of validation data points)

SD = Standard deviation of the errors between model-calculated and observed REDs in the validation data set

RED_{Calc} = Model-calculated RED prediction for any given operation point

The dose-algorithm developed for this reactor is discussed in Section 5.3.5. Refer to Figure 5-14 for a comparison of the predicted MS2, T1 or Q β RED to the observed MS2, T1 or Q β RED. The residuals were determined by comparing the calculated RED (RED_{Calc}) against the observed RED. With 81 data points, t_{stat} is 1.99 and the standard deviation (SD) of the residuals was determined to be 3.024 mJ/cm².

The expression for U_{IN} for the Siemens H-4XE-HO (2W-1B-1C) becomes:

$$U_{IN} = \left(\frac{1.99 \times 3.024}{RED_{Calc}} \right) \times 100\% = \left(\frac{601.7}{RED_{Calc}} \right)$$

As noted by the above equation, U_{IN} depends upon the RED_{Calc} value determined for a specific operating condition. The RED_{Calc} , in turn, is dependent on the sensitivity value being used for a specific application. An example of the calculated U_{IN} can be shown as a function of the RED_{Calc} at a UVT of 50%. This can be done for sensitivities associated with T1 (5 mJ/cm²/LI), Qβ (11 mJ/cm²/LI) and MS2 (20 mJ/cm²/LI). From the dose algorithm and sensor model presented in Section 5.3.3 and 5.3.4, respectively, at UVT = 50% and flow = 300 gpm:

The RED_{Calc} at a sensitivity equivalent to T1 = 22.0 mJ/cm²

The RED_{Calc} at a sensitivity equivalent to Qβ = 30.1 mJ/cm²

The RED_{Calc} at a sensitivity equivalent to MS2 = 38.2 mJ/cm²

These RED_{Calc} values are then inserted into the U_{IN} expression:

$$U_{IN} (T1) = 601.7/22.0 = 27.4\%$$

$$U_{IN} (Q\beta) = 601.7/30.1 = 20.0\%$$

$$U_{IN} (MS2) = 601.7/38.2 = 15.8\%$$

This same calculation would be used at any sensitivity that is associated with a given microbe. These should fall within the range of sensitivity covered by the validation (5 to 20 mJ/cm²/LI)

7.2.4 Calculation of the Validation Uncertainty (U_{Val})

Based on Figure 7-1 and the results of the analyses for U_S , U_{DR} and U_{IN} , the value for U_{Val} simply becomes U_{IN} , expressed as a percentage:

$$U_{Val} = U_{IN}$$

7.3 CALCULATION OF THE VALIDATION FACTOR

7.3.1 Validation Factor (VF)

With its specific elements assessed and defined, as discussed in Section 7.2, the validation factor for the Siemens H-4XE-HO (2W-1B-1C) can be expressed as a function of the U_{IN} :

$$VF = 1 + (U_{IN}/100)$$

Substituting the function for U_{IN} ,

$$VF = 1 + (6.017/RED_{Calc})$$

If the above examples are carried through this step, the Validation Factors for the given conditions are computed as:

$$VF (T1) = 1 + (6.017/22.0) = 1.274$$

$$VF (Q\beta) = 1 + (6.017/30.1) = 1.20$$

$$VF (MS2) = 1 + (6.017/38.2) = 1.158$$

Figure 7-2 presents a series of solutions for VF at a UVT of 50% and sensitivities ranging between 5 and 20 mJ/cm²/LI. VF is shown as a function of flow/lamp under these specific and fixed operating conditions. Similar calculations can be made at alternate operating conditions. Note that as RED increases (flow decreases) the VF decreases. These calculations are appropriate only when the UVS of the targeted pathogen is equal to or greater than the sensitivity chosen for the calculations. Thus, if the sensitivity of the organism of concern is 10 mJ/cm²/LI, then UVS must be 10 or less when conducting the calculations for the VF.

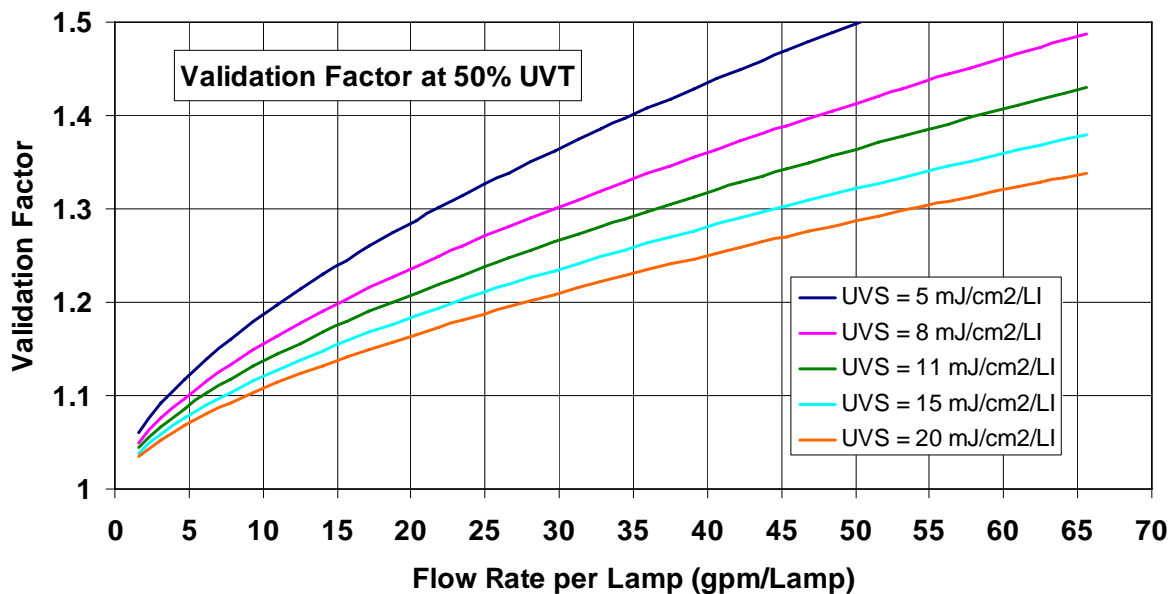

Figure 7-2. Example solutions for Validation Factor at fixed operating conditions and a range of UV sensitivity.

7.4 VALIDATED RED AND LOG INACTIVATION

As discussed earlier, the validated RED (RED_{val}), is calculated as:

$$RED_{val} = \frac{RED_{Calc}}{VF}$$

The calculation of VF was presented in Section 7.3. Thus, if the same examples are carried, the validated, or credited, RED can be determined:

At the lower UVS (5 mJ/cm²/LI):

$$RED_{val} = 20.2/1.274 = 15.9 \text{ mJ/cm}^2$$

At the middle UVS (11 mJ/cm²/LI):

$$RED_{val} = 30.1/1.20 = 25.1 \text{ mJ/cm}^2$$

At the upper UVS (20 mJ/cm²/LI):

$$RED_{val} = 38.2/1.158 = 33.0 \text{ mJ/cm}^2$$

Figure 7-3 presents solutions at a UVT of 50% across the same range of UV sensitivity. It is important to note that this assumes the system sensors have been confirmed to meet the sensor model described in Section 5.3.6. Hereto, it is important to note that the UVS used for the RED calculation is equal to or less than the UVS of the targeted pathogen. The solutions for validated RED (RED_v), such as those shown on Figure 7-3 as a function of flow/lamp, can be reported on the PLC of the H-4XE-HO (2W-1B-1C), based on monitored real-time operating conditions.

Table 7-1 provides credited RED solutions across a broad range of operating conditions for the unit (S, UVT and Q/L), at sensitivities between 5 and 20 mJ/cm²/LI. Figure 7-3 displayed those calculations pertinent to the 50% UVT conditions. Similar plots can be generated by the user at alternate conditions.

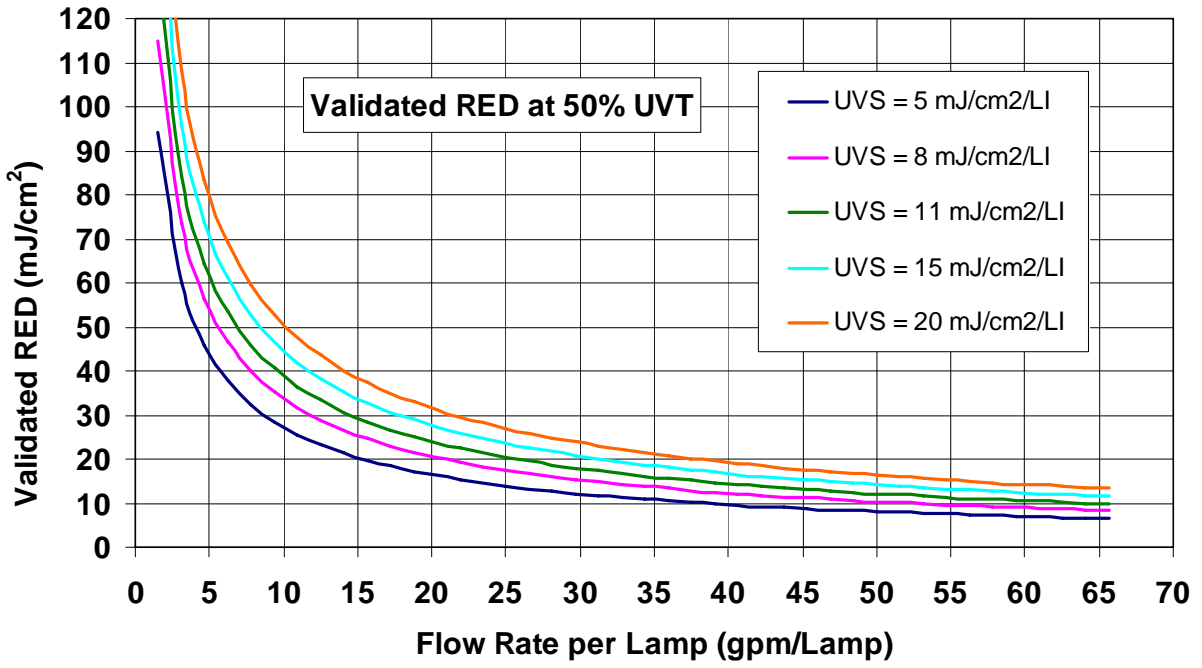

Figure 7-3. Credited RED at 50% UVT across a range of UV sensitivities.

Table 7-1. Credited RED Solutions

UVT (%T)	S (%)	Q/L (gpm/L)	Credited RED (mJ/cm ²) at UVS (mJ/cm ² /LI)				
			5	8	11	15	20
50	20.0	8.4	30.7	37.9	43.7	50.1	56.8
50	20.0	10.0	27.2	33.7	38.8	44.6	50.5
50	20.0	14.0	21.4	26.6	30.8	35.4	40.3
50	20.0	18.0	17.8	22.2	25.8	29.7	33.9
50	20.0	25.0	13.9	17.5	20.4	23.6	27.0
50	20.0	30.0	12.1	15.3	17.8	20.7	23.7
50	20.0	35.0	10.7	13.6	15.9	18.5	21.2
50	20.0	40.0	9.6	12.3	14.4	16.7	19.2
50	20.0	45.0	8.8	11.2	13.1	15.3	17.6
50	20.0	50.0	8.1	10.3	12.1	14.2	16.3
50	20.0	54.0	7.6	9.7	11.4	13.3	15.4
55	27.1	8.4	38.8	47.7	54.8	62.7	71.0
55	27.1	10.0	34.4	42.4	48.8	55.9	63.3
55	27.1	14.0	27.2	33.7	38.9	44.6	50.6
55	27.1	18.0	22.7	28.3	32.7	37.6	42.7
55	27.1	25.0	17.9	22.4	26.0	30.0	34.1
55	27.1	30.0	15.6	19.6	22.8	26.3	30.1
55	27.1	35.0	13.9	17.5	20.4	23.6	27.0
55	27.1	40.0	12.6	15.9	18.5	21.4	24.5
55	27.1	45.0	11.5	14.5	17.0	19.7	22.6
55	27.1	50.0	10.6	13.4	15.7	18.2	20.9
55	27.1	54.0	9.9	12.6	14.8	17.2	19.8
60	35.7	8.4	47.8	58.6	67.3	76.8	86.8
60	35.7	10.0	42.5	52.2	60.0	68.5	77.5
60	35.7	14.0	33.7	41.6	47.9	54.9	62.1
60	35.7	18.0	28.3	35.1	40.4	46.4	52.6
60	35.7	25.0	22.4	27.9	32.3	37.1	42.2
60	35.7	30.0	19.6	24.5	28.4	32.7	37.2
60	35.7	35.0	17.5	21.9	25.5	29.4	33.5
60	35.7	40.0	15.9	19.9	23.2	26.7	30.5
60	35.7	45.0	14.5	18.3	21.3	24.6	28.1
60	35.7	50.0	13.4	16.9	19.7	22.8	26.1
60	35.7	54.0	12.6	16.0	18.6	21.6	24.7
65	46.0	8.4	57.8	70.7	81.0	92.3	104.2
65	46.0	10.0	51.4	63.1	72.3	82.5	93.1
65	46.0	14.0	41.0	50.4	57.9	66.2	74.9
65	46.0	18.0	34.5	42.6	49.0	56.1	63.5
65	46.0	25.0	27.4	34.0	39.2	45.0	51.1
65	46.0	30.0	24.1	30.0	34.6	39.8	45.2
65	46.0	35.0	21.6	26.9	31.1	35.8	40.7
65	46.0	40.0	19.6	24.5	28.3	32.6	37.2
65	46.0	45.0	18.0	22.5	26.1	30.1	34.3
65	46.0	50.0	16.6	20.8	24.2	27.9	31.8
65	46.0	54.0	15.7	19.7	22.9	26.4	30.2

Table 7-1. Credited RED Solutions (Continued)

UVT (%T)	S (%)	Q/L (gpm/L)	Credited RED (mJ/cm ²) at UVS (mJ/cm ² /LI)				
			5	8	11	15	20
70	58.1	8.4	68.7	83.9	96.0	109.3	123.3
70	58.1	10	61.3	74.9	85.8	97.8	110.3
70	58.1	14	49.0	60.1	68.9	78.6	88.8
70	58.1	18	41.3	50.8	58.4	66.7	75.5
70	58.1	25	33.0	40.7	46.9	53.7	60.8
70	58.1	30	29.1	36.0	41.4	47.5	53.9
70	58.1	35	26.1	32.3	37.3	42.8	48.6
70	58.1	40	23.7	29.4	34.0	39.1	44.4
70	58.1	45	21.8	27.1	31.4	36.1	41.0
70	58.1	50	20.2	25.2	29.1	33.6	38.2
70	58.1	54	19.1	23.8	27.6	31.8	36.2
75	72.3	8.4	80.6	98.3	112.3	127.8	144.0
75	72.3	10	71.9	87.8	100.4	114.4	128.9
75	72.3	14	57.7	70.6	80.8	92.2	104.0
75	72.3	18	48.8	59.8	68.6	78.3	88.5
75	72.3	25	39.0	48.1	55.2	63.2	71.4
75	72.3	30	34.4	42.5	48.9	56.0	63.4
75	72.3	35	31.0	38.3	44.1	50.5	57.2
75	72.3	40	28.2	34.9	40.3	46.2	52.4
75	72.3	45	25.9	32.2	37.1	42.6	48.4
75	72.3	50	24.1	29.9	34.5	39.7	45.1
75	72.3	54	22.8	28.3	32.8	37.7	42.8
80	88.7	8.4	93.5	113.9	130.0	147.8	166.5
80	88.7	10	83.5	101.8	116.3	132.3	149.1
80	88.7	14	67.1	81.9	93.7	106.8	120.4
80	88.7	18	56.8	69.6	79.7	90.8	102.5
80	88.7	25	45.6	56.0	64.3	73.4	82.9
80	88.7	30	40.3	49.6	57.0	65.1	73.7
80	88.7	35	36.3	44.7	51.4	58.8	66.6
80	88.7	40	33.1	40.8	47.0	53.8	61.0
80	88.7	45	30.5	37.7	43.4	49.8	56.4
80	88.7	50	28.3	35.1	40.4	46.4	52.6
80	88.7	54	26.8	33.2	38.4	44.0	50.0

SECTION 8

EXAMPLE CALCULATIONS FOR SIZING THE SIEMENS H-4XE-HO (2W-1B-1C)

8.1 DESIGN CONDITIONS FOR EXAMPLE APPLICATIONS

An example is given to illustrate the calculations that can be conducted to evaluate the sizing of the Siemens H-4XE-HO (2W-1B-1C). Consider the following design condition:

Flow Rate: 6000 gpm (8.64 mgd)

UVT: 55%

Performance Requirement with two reactors in series:

Application 1: Secondary effluent, Fecal Coliform < 200 cfu/100 mL (2.3 Log)

Application 2: Reuse, MS2 dose > 80 mJ/cm²

8.1.1 Application 1

This is a “low-dose” application, directed at typical secondary effluents discharged from wastewater treatment plants. In such cases, collimated-beam measurements would be made to develop a dose-response (DR) relationship, based on fecal coliform. An example of such data is provided in Figure 8-1, showing the tailing effect due to particulates. Taking the non-aggregated, linear portion of the curve, the UV sensitivity is estimated to be 6.9 mJ/cm²/LI. From the DR data, one can observe that the maximum effective dose is in the vicinity of 25 mJ/cm², beyond which the particulate coliform control and little apparent disinfection occurs. In order to meet the specification, a lower target fecal coliform is considered; and the dose is set at 25 mJ/cm².

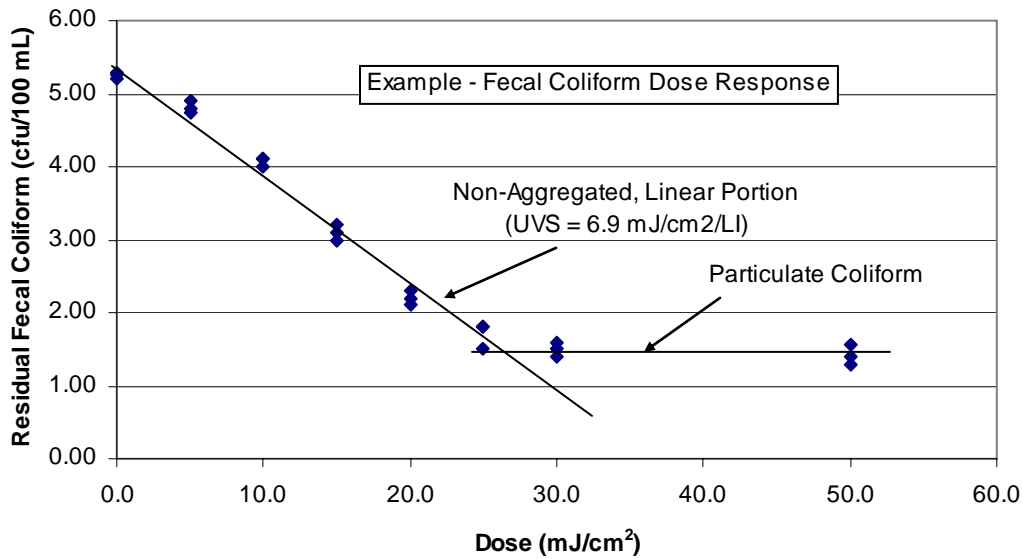

Figure 8-1. Example Fecal Coliform Dose-Response curve.

As noted, sizing should consider having two reactors in series to meet this targeted dose. Since dose is additive, each reactor would need to deliver at least 12.5 mJ/cm² at the design flow and UVT. From Table 7-1, at a UVT of 55%, the value of S is 27.07 (this uses the calculation shown in Section 5.3.4). Using the dose algorithm, compute the RED_{calc} as a function of flow/lamp.

From Section 5.3.3, the RED algorithm is:

$$RED = 10^a \cdot (Q/L)^b \cdot S^c \cdot UVS^d$$

Where:

Q = Flow rate, gpm

L = Number of lamps

S = Average Sensor Reading (%)

UVS = UV Sensitivity (mJ/cm²/Log Inactivation)

a, b, c, d = Equation coefficients

Coefficient	Value
a	0.950550
b	-0.609884
c	0.683241
d	0.398391

S has been determined at 27.07, reflecting the same placement of the sensor as in the validation unit. The UVS in this case is 6.9 mJ/cm²/LI, as shown on Figure 8-1 for the site-specific fecal coliform. The flow/lamp input can be varied to evaluate RED_{calc} as a function of hydraulic loading. For example, at 30 gpm/lamp, the RED_{calc} is:

$$RED = 10^{0.950550} \times (30)^{-0.609884} \times (27.07)^{0.683241} \times (6.9)^{0.398391}$$

$$RED = 18.3 \text{ mJ/cm}^2$$

Figure 8-2 presents solutions for RED_{calc} as a function of flow. These must then be adjusted for the Validation Factor (VF).

As discussed in Section 7.3, the VF is:

$$VF = 1 + (6.071/RED_{Calc})$$

Therefore, at 30 gpm/lamp, the credited RED is:

$$RED_{val} = 18.3 / (1 + (6.071/18.3)) = 13.74 \text{ mJ/cm}^2$$

Solutions for credited RED are also shown on Figure 8-2. As shown, a hydraulic loading equal to or less than 49.7 gpm/lamp will yield an RED of at least 12.5 mJ/cm² in a single reactor; two reactors would be placed in series for a credited RED of 25 mJ/cm². At the design flow of 6000 gpm, each bank would require 6000/49.7 = 120 lamps. This may be accommodated by two parallel channels, with at least 60 lamps per reactor. This analysis is simplified as an example and does not address redundancy or other design considerations.

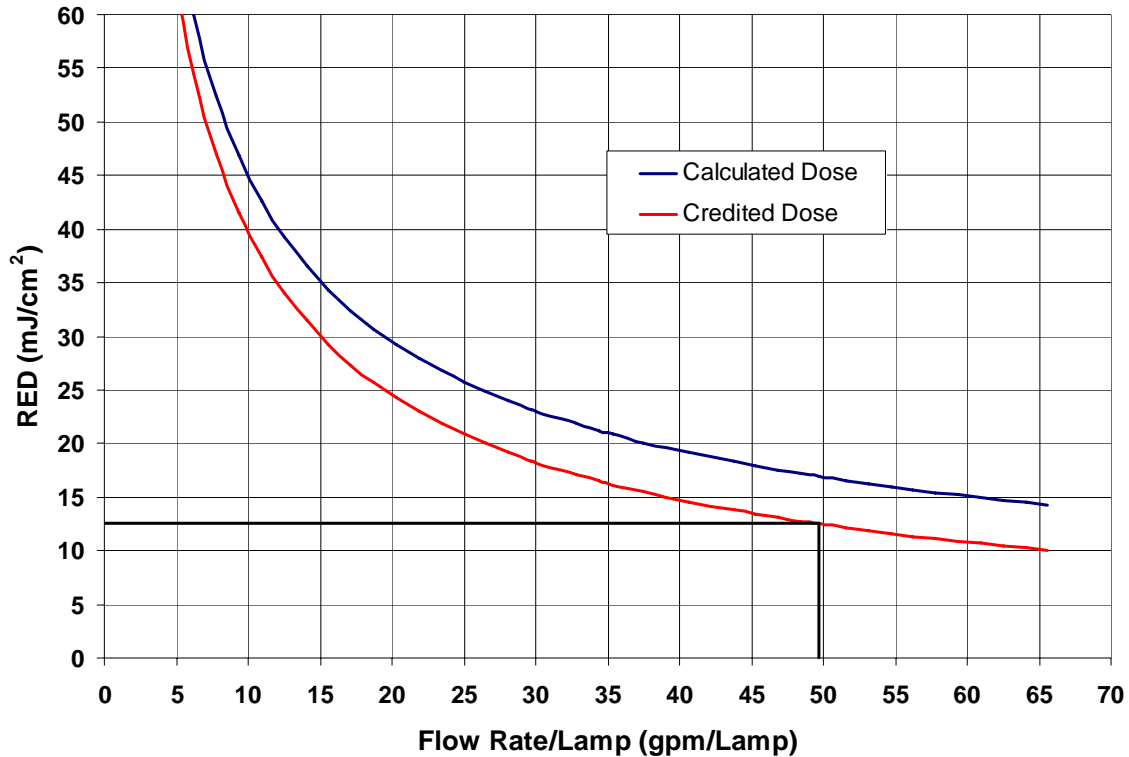

Figure 8-2. Example calculation of RED as a function of flow (55% UVT) for an H-4XE-HO (2W-1B-1C) Reactor module in a low-dose application.

8.1.2 Application 2

In the second application, the performance requirement is to meet an MS2 RED of 80 mJ/cm², a criterion typically found with reuse applications after membrane-filtered secondary treatment. The approach is the same as discussed above for the “low-dose” application, except that an MS2 UV sensitivity value is used. This is 20 mJ/cm²/LI. Solutions for calculated and credited RED are provided in Figure 8.3. In this case, two reactors are placed in series, with a hydraulic loading of 19.85 gpm/lamp. To meet the design flow of 6000 gpm, approximately 303 lamps are needed for each reactor. This would likely be divided to two or three parallel channels. Note that this is provided as a simplified example – other design aspects such as redundancy are not considered.

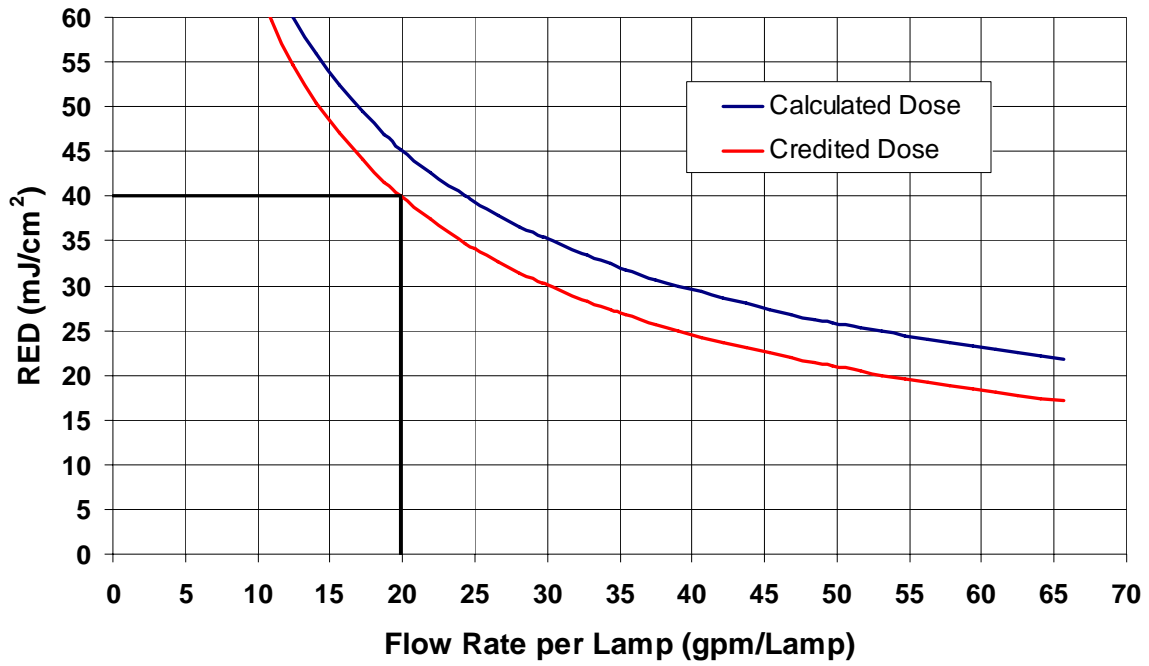

Figure 8-3. Example calculation of RED as a function of flow (55% UVT) for an H-4XE-HO (2W-1B-1C) Reactor module in a reuse application.

SECTION 9

REFERENCES

1. HydroQual, INC., (January 2002). “Generic Verification Protocol for Secondary Effluent and Water Reuse Disinfection Applications” version 3.4. Prepared for NSF International and the U.S. Environmental Protection Agency under the Environmental Technology Verification Program, Source Water Projection Pilot. Mahwah, NJ
2. ISO 10705-1: International Standards Organization (ISO). (1995). “Water Quality-Detection and Enumeration of Bacteriophage. Part I: Enumeration of F-Specific RNA Bacteriophage.” Switzerland: International Standards Organization
3. National Water Research Institute (NWRI)/AWWA Research Foundation (AwwaRF) *Ultraviolet Disinfection Guidelines for Drinking Water and Water Reuse*, Second Edition. Fountain Valley, CA, 2003.
4. USEPA – Environmental Technology Program, *Verification Protocol for Secondary Effluent and Water Reuse Disinfection Applications*, NSF International Water Quality Center, October 2002
5. USEPA *Ultraviolet Disinfection Guidance Manual for the Final Long Term 2 Enhanced Surface Water Treatment Rule*, United States Environmental Protection Agency, Office of Water, EPA-815-R-06-007, November, 2006