

Chapter V

Direct Push Technologies

Contents

Exhibits	V-v
Direct Push Technologies	V-1
Direct Push Rod Systems	V-4
Single-Rod Systems	V-4
Cased Systems	V-4
Discussion And Recommendations	V-4
Direct Push Sampling Tools	V-8
Soil Sampling Tools	V-8
Nonsealed Soil Samplers	V-8
Barrel Samplers	V-8
Split-Barrel Samplers	V-10
Thin-Wall Tube Samplers	V-10
Sealed Soil (Piston) Samplers	V-10
Discussion And Recommendations	V-11
Lithologic Description/Geotechnical Characterization	V-11
Chemical Analysis	V-11
Sample Contamination	V-13
Active Soil-Gas Sampling Tools	V-13
Expendable Tip Samplers	V-14
Retractable Tip Samplers	V-16
Exposed-Screen Samplers	V-16
Sampling With Cased Systems	V-16
Methods For Retrieving Active Soil-Gas Samples	V-17
Sampling Through Probe Rods	V-17
Sampling Through Tubing	V-17
Discussion And Recommendations	V-17
Groundwater Sampling Tools	V-18
Exposed-Screen Samplers	V-20
Sealed-Screen Samplers	V-26
Discussion And Recommendations	V-27
General Issues Concerning Groundwater Sampling	V-27
Loss Of VOCs	V-28
Stratification Of Contaminants	V-29
Conclusion	V-29
<i>In Situ</i> Measurements Using Specialized Direct Push Probes	V-30
Cone Penetrometer Testing	V-30

Three-Channel Cone	V-31
Piezocone	V-34
Geophysical And Geochemical Logging Probes	V-34
Conductivity Probes	V-34
Nuclear Logging Tools	V-36
Chemical Sensors	V-36
Discussion And Recommendations	V-37
Equipment For Advancing Direct Push Rods	V-39
Manual Hammers	V-39
Hand-Held Mechanical Hammers	V-39
Percussion Hammers And/Or Vibratory Heads Mounted	
On Small Vehicles	V-41
Small Hydraulic Presses Anchored To The Ground	V-41
Conventional Drilling Rigs	V-41
Trucks Equipped With Hydraulic Presses	V-42
Discussion And Recommendations	V-42
Methods For Sealing Direct Push Holes	V-44
Surface Pouring	V-45
Re-entry Grouting	V-45
Retraction Grouting	V-47
Grouting During Advancement	V-48
Discussion And Recommendations	V-48
Direct Push Equipment Manufacturers	V-52
References	V-57
Peer Reviewers	V-62

Exhibits

Number	Title	Page
V-1	Overview Of Direct Push Technologies	V-3
V-2	Schematic Drawing Of Single And Cased Direct Push Rod Systems	V-5
V-3	Comparison Of Single-Rod And Cased Systems	V-7
V-4	Types Of Nonsealed Direct Push Soil Sampling Tools	V-9
V-5	Using The Sealed Direct Push Soil Sampler (Piston Sampler)	V-12
V-6	Summary Of Sealed And Nonsealed Soil Sampler Applications	V-14
V-7	Types Of Direct Push Soil-Gas Sampling Tools	V-15
V-8	Summary Of Soil-Gas Sampling Tool Applications	V-19
V-9	Permanent Monitoring Well Installed With Pre-Packed Well Screens	V-21
V-10	Types Of Direct Push Groundwater Sampling Tools	V-22
V-11	Using The Check Valve Tubing Pump	V-24
V-12	Using A Drive-Point Profiler	V-25
V-13	Summary Of Groundwater Sampling Tool Applications	V-28
V-14	Components Of A CPT Piezocone	V-32
V-15	Example CPT Data	V-33
V-16	CPT Soil Behavior Types	V-33
V-17	Small-Diameter Direct Push Conductivity Probe	V-35

V-18	Summary Of <i>In Situ</i> Logging Equipment Used With Direct Push Technologies	V-38
V-19	Typical Equipment Used To Advance Direct Push Rods	V-40
V-20	Summary Of Equipment For Advancing Direct Push Rods	V-43
V-21	Methods For Sealing Direct Push Holes	V-46
V-22	Sealing Direct Push Holes With Cased Systems	V-49
V-23	Sealing Direct Push Holes By Grouting During Advancement	V-50
V-24	Summary Of Direct Push Hole Sealing Applications	V-51
V-25	Direct Push Equipment Manufacturers	V-52
V-26	Matrix Of Manufacturers And Equipment	V-54

Chapter V

Direct Push Technologies

Direct push (DP) technology (also known as “direct drive,” “drive point,” or “push” technology) refers to a growing family of tools used for performing subsurface investigations by driving, pushing, and/or vibrating small-diameter hollow steel rods into the ground. By attaching sampling tools to the end of the steel rods they can be used to collect soil, soil-gas, and groundwater samples. DP rods can also be equipped with probes that provide continuous *in situ* measurements of subsurface properties (e.g., stratigraphy, contaminant distribution). DP equipment can be advanced with various methods ranging from 30 pound manual hammers to trucks weighing 60 tons.

DP technology has developed in response to a growing need to assess contaminated sites more completely and more quickly than is possible with conventional methods. As explained in Chapter II, The Expedited Site Assessment Process, conventional assessments have relied heavily on traditional drilling methods, primarily hollow stem augers (HSA), to collect soil and groundwater samples and install permanent monitoring wells. Because installing permanent monitoring wells with HSA is a relatively slow process that provides a limited number of samples for analysis, the most economical use for the equipment is to perform site assessments in phases with rigid work plans and off-site analysis of samples.

With the development of DP technologies, large, permanent monitoring wells are no longer the only method for collecting groundwater samples or characterizing a site. Multiple soil, soil-gas, and groundwater samples can now be collected rapidly, allowing high data quality analytical methods to be used on-site, economically. As a result, DP technologies have played a major role in the development of expedited site assessments (ESAs).

DP technologies are most applicable in unconsolidated sediments, typically to depths less than 100 feet. In addition to being used to collect samples from various media, they can also be used to install small-diameter (*i.e.*, less than 2 inches) temporary or permanent monitoring wells and small-diameter piezometers (used for measuring groundwater gradients). They have also been used in the installation of remediation equipment such as soil vapor extraction wells and air sparging injection points. Penetration is limited in semiconsolidated sediments and is generally not possible in consolidated formations, although highly weathered bedrock (*i.e.*, saprolite) is an exception for some equipment. DP equipment may also be limited in unconsolidated sediments with high percentages of gravels and cobbles. As a result, other drilling methods are necessary in site assessment and remediation activities where geological conditions are unfavorable

for DP technologies or where larger diameter (*i.e.*, greater than 2 inches) wells are needed.

An additional benefit of DP technologies is that they produce a minimal amount of waste material because very little soil is removed as the probe rods advance and retract. Although this feature may result in some soil compaction that could reduce the hydraulic conductivity of silts and clays, methods exist for minimizing resulting problems.

In contrast, although most other drilling methods remove soil from the hole, resulting in less compaction, conventional drilling methods create a significant amount of contaminated cuttings and they also smear clay and silt across more permeable formations which can obscure their true nature. Moreover, these other drilling methods have the potential of causing a redistribution of contamination as residual and free product are brought to the surface.

Choosing a DP method (or combination of DP methods) appropriate for a specific site requires a clear understanding of data collection goals because many tools are designed for only one specific purpose (*e.g.*, collection of groundwater samples). This chapter contains descriptions of the operation of specific DP systems and tools, highlighting their main advantages and limitations; its purpose is to assist regulators in evaluating the appropriateness of these systems and tools.

This chapter does not contain discussions of specific tools manufactured by specific companies because equipment is evolving rapidly. Not only are unique tools being invented, but existing equipment is being used in creative ways to meet the needs of specific site conditions. As a result, the distinctions between types of DP equipment is becoming blurred and it is necessary to focus on component groups rather than entire DP systems. The four component groups discussed in this chapter include:

- Rod systems;
- Sampling tools;
- *In situ* measurements using specialized probes; and
- Equipment for advancing DP rods.

The chapter also includes a discussion of methods for sealing DP holes because of their importance in preventing the spread of contaminants and, therefore, in the selection of DP equipment. The cost of various DP equipment is not discussed in this chapter because cost estimates become quickly outdated due to rapid changes in the industry. An overview of the advantages and limitations of DP equipment and systems discussed in this chapter are presented in Exhibit V-1.

**Exhibit V-1
Overview Of Direct Push Technologies**

Direct Push Component	Example	Advantages	Limitations
Probing systems	Single-rod or cased	Minimizes the need for waste disposal or treatment	Compaction of sediments may decrease hydraulic conductivity
Soil, soil-gas, and groundwater sampling	Piston samplers, expendable tip samplers	Relatively rapid	Permanent monitoring wells are limited to 2 inch diameter or less
<i>In situ</i> measurement of subsurface conditions	Conductivity probes, laser induced fluorescence	Can be used to rapidly log site	Correlation with boring logs is necessary
Methods for advancing probe rods	Percussion hammers, hydraulic presses	Some methods are extremely portable	Very dense, consolidated formations are generally impenetrable
Sealing methods	Re-entry grouting, retraction grouting	Holes can be sealed so that contaminants cannot preferentially migrate through them	Appropriate sealing methods may limit sampling equipment options

Direct Push Rod Systems

DP systems use hollow steel rods to advance a probe or sampling tool. The rods are typically 3-feet long and have male threads on one end and female threads on the other. As the DP rods are pushed, hammered, and/or vibrated into the ground, new sections are added until the target depth has been reached, or until the equipment is unable to advance (*i.e.*, refusal). There are two types of rod systems, single-rod and cased. Both systems allow for the collection of soil, soil-gas, and groundwater samples. Exhibit V-2 presents a schematic drawing of single-rod and cased DP rod systems.

Single-Rod Systems

Single-rod systems are the most common types of rods used in DP equipment. They use only a single string (*i.e.*, sequence) of rods to connect the probe or sampling tool to the rig. Once a sample has been collected, the entire string of rods must usually be removed from the probe hole. Collection of samples at greater depths may require re-entering the probe hole with an empty sampler and repeating the process. The diameter of the rods is typically around 1 inch, but it can range from 0.5 to 2.125 inches.

Cased Systems

Cased systems, which are also called dual-tube systems, advance two sections--an outer tube, or casing, and a separate inner sampling rod. The outer casing can be advanced simultaneously with, or immediately after, the inner rods. Samples can, therefore, be collected without removing the entire string of rods from the ground. Because two tubes are advanced, outer tube diameters are relatively large, typically 2.4 inches, but they can range between 1.25 and 4.2 inches.

Discussion And Recommendations

Single-rod and cased systems have overlapping applications; they can be used in many of the same environments. However, when compared with cased systems, single-rod systems are easier to use and are capable of collecting soil, soil-gas, or groundwater samples more rapidly when only one sample is retrieved. They are particularly useful at sites where the stratigraphy is either relatively homogeneous or well delineated.

The primary advantage of cased DP systems is that the outer casing prevents the probe hole from collapsing and sloughing during sampling. This feature allows for the collection of continuous soil samples that do not contain any slough, thereby preventing sample contamination. Because only the inner sample barrel is removed, and not the entire rod string, cased systems are faster than single-rod systems for continuous sampling at depths below 10 feet. The collection of continuous samples is especially important at geologically heterogeneous sites where direct visual observation of lithology is necessary to ensure that small-scale features such as sand stringers in aquitards or thin zones of non-aqueous-phase liquids (NAPLs) are not missed.

Another advantage of cased systems is that they allow sampling of groundwater after the zone of saturation has been identified. This feature allows investigators to identify soils with relatively high hydraulic conductivities from which to take groundwater samples. If only soils with low hydraulic conductivity are present, investigators may choose to take a soil sample and/or install a monitoring well. With most single-rod systems, groundwater samples must be taken without prior knowledge of the type of soil present. (Some exposed-screen samplers used with single-rod systems as described in the *Groundwater Sampling Tools* section are an exception.)

A major drawback of single-rod systems is that they can be slow when multiple entries into the probe hole are necessary, such as when collecting continuous soil samples. In addition, in non-cohesive formations (*i.e.*, loose sands), sections of the probe hole may collapse, particularly in the zone of saturation, enabling contaminated soil present to reach depths that may be otherwise uncontaminated. Sloughing soils may, therefore, contaminate the sample. This contamination can be minimized through the use of sealed soil sampling tools (*i.e.*, piston samplers, which are discussed in more detail in the *Soil Sampling Tools* section that follows).

Multiple entries made with single-rod systems into the same hole should be avoided when NAPLs are present because contaminants could flow through the open hole after the probe rods have been removed; particularly if dense-non-aqueous phase liquids (DNAPLs) are present. In addition, multiple entries into the probe hole may result in the ineffective sealing of holes. (These issues are discussed in more detail in *Methods For Sealing Direct Push Holes* at the end of the chapter.) If samples need to be taken at different depths in zones of significant NAPL contamination, single-rod systems can be used, but new entries into soil should be made next to previous holes.

The major drawback of cased systems is that they are more complex and difficult to use than single-rod systems. In addition, because they require larger-diameter probe rods, cased systems require heavier DP rigs, larger percussion hammers, and/or vibratory systems for advancing the probe rod. Furthermore,

even with the additional equipment, penetration depths are often not as great as are possible with single-rod systems and sampling rates are slower when single, discrete samples are collected. Exhibit V-3 summarizes the comparison of single and cased systems.

**Exhibit V-3
Comparison Of Single-Rod And Cased Systems**

	Single-Rod	Cased
Allows collection of a single soil, soil-gas, or groundwater sample	✓ (faster)	✓
Allows collection of continuous soil samples	✓ ¹	✓ ² (faster)
Allows collection of groundwater sampling after determining ideal sampling zone³		✓
Lighter carrier vehicles can be used to advance rods	✓	
Greater penetration depths	✓	
Multiple soil samples can be collected when NAPLs are present		✓

¹ Sloughed soil may also be collected.

² Faster at depths below approximately 10 feet.

³ Some exposed-screen samplers, discussed in the groundwater sampling section, also have this ability.

Direct Push Sampling Tools

A large number of DP tools have been developed for sampling soil, soil-gas, and groundwater. Each of these tools was designed to meet a specific purpose; however, many of these tools also have overlapping capabilities. This section describes the commonly used tools currently available and clarifies their applications. All of the tools described in this section can be advanced by rigs designed specifically for DP. In addition, many of these tools can also be used with conventional drilling rigs.

Soil Sampling Tools

There are two types of soil samplers: Nonsealed and sealed. Nonsealed soil sampling tools remain open as they are pushed to the target depth; sealed soil samplers remain closed until they reach the sampling depth.

Nonsealed Soil Samplers

The three most commonly used nonsealed soil samplers are barrel, split-barrel, and thin-walled tube samplers. All three are modified from soil samplers used with conventional drilling rigs (*e.g.*, HSA). The primary difference is that DP soil samplers have smaller diameters. Nonsealed soil samplers should only be used in combination with single-rod systems when sampling in uncontaminated fine-grained, cohesive formations because multiple entries into the probe hole are required. When sloughing soils and cross-contamination are a significant concern, nonsealed soil samplers may be used with cased DP systems or more conventional sampling methods (*e.g.*, HSA). In addition, nonsealed samplers necessitate continuous soil coring because there is no other way to remove soil from the hole. All three types of nonsealed soil sampling tools are presented in Exhibit V-4.

Barrel Samplers

Barrel samplers, also referred to as solid-barrel or open-barrel samplers, consist of a head assembly, a barrel, and a drive shoe (Exhibit V-4a). The sampler is attached to the DP rods at the head assembly. A check valve, which allows air or water to escape as the barrel fills with soil, is located within the head assembly. The check valve improves the amount of soil recovered in each sample by allowing air to escape. With the use of liners, samples can be easily removed for volatile organic compound (VOC) analysis or for observation of soil structure.

Without the use of liners, soil cores must be physically extruded using a hydraulic ram which may damage fragile structures (*e.g.*, root holes, desiccation cracks).

Split-Barrel Samplers

Split-barrel samplers, also referred to as “split-spoon” samplers, are similar to barrel samplers except that the barrels are split longitudinally (Exhibit V-4b) so that the sampler can be easily opened. The primary advantage of split-barrel samplers is that they allow direct observation of soil cores without the use of liners and without physically extruding the soil core. As a result, split-barrel samplers are often used for geologic logging. Split-barrel samplers, however, may cause more soil compaction than barrel samplers because the tool wall thickness is often greater. In addition, although liners are not compatible with all split-barrel samplers, liners are necessary if samples are used for analysis of VOCs.

Thin-Wall Tube Samplers

Thin-wall tube samplers (larger diameter samplers are known as Shelby Tubes) are DP sampling tools used primarily for collecting undisturbed soil samples (Exhibit V-4c). The sampling tube is typically attached to the sampler head using recessed cap screws or rubber expanding bushings. The walls of the samplers are made of thin steel (*e.g.*, 1/16-inch thick). The thin walls of the sampler cause the least compaction of the soil, making it the DP tool of choice for geotechnical sample analysis (*e.g.*, laboratory measurement of hydraulic conductivity, moisture content, density, bearing strength).

Samples are typically preserved, inside the tube, for off-site geotechnical analysis. If the samples are intended for on-site chemical analysis, they can be extruded from the sampler using a hydraulic ram, or the tubes can be cut with a hacksaw or tubing cutter. Because of their fragile construction, thin-wall tube samplers can be used only in soft, fine-grained sediments. In addition, the sampler is usually pushed at a constant rate rather than driven with impact hammers. If samples are needed for off-site VOC analysis, the tube is used as the sample container which can be capped and preserved.

Sealed Soil (Piston) Samplers

Piston samplers are the only type of sealed soil sampler currently available. They are similar to barrel samplers, except that the opening of the sampler is sealed with a piston. Thus, while the sampler is re-inserted into an open probe hole, contaminated soil and water can be prevented from entering the

sampler. The probe displaces the soil as it is advanced. When the sampler has been pushed to the desired sampling depth, the piston is unlocked by releasing a retaining device, and subsequent pushing or driving forces soil into the sampler (Exhibit V-5).

Several types of piston samplers are currently available. Most use a rigid, pointed piston that displaces soil as it is advanced. Piston samplers are typically air- and water-tight; however, if o-ring seals are not maintained, leakage may occur. Piston samplers also have the advantage of increasing the recovery of unconsolidated sediments as a result of the relative vacuum that is created by the movement of the piston.

Discussion And Recommendations

Issues affecting the selection of soil samplers include the ability of the sampler to provide samples for lithological description, geotechnical characterization, or chemical analysis. In addition, the potential of a sample contamination with a specific sampler must be considered.

Lithologic Description/Geotechnical Characterization

All soil samplers can be used to some extent for lithologic description and geotechnical characterization but because the disturbance to the sample varies between tools, the preferred tool will vary depending on the application. Split-barrel samplers or barrel samplers used with split-liners are the best DP sampling methods for lithological description because they allow the investigator to directly inspect the soil without further disturbing the sample. Thin-walled tube samplers are best for collecting undisturbed samples needed for geotechnical analysis; barrel and piston samplers are the next best option. With single-rod systems, piston samplers are the only tools that can reliably be used for these same objectives because they produce discrete soil samples.

Chemical Analysis

All sealed or nonsealed soil samplers can be used for the collection of samples for VOC analysis. If samples are analyzed on-site, liners of various materials (*e.g.*, brass, stainless steel, clear acrylic, polyvinylchloride [PVC]) can be used as long as the soil is immediately subsampled and preserved. Soil samples intended for off-site analysis should be collected directly into brass or stainless steel liners within the DP soil sampling tool. Once the tool has been retrieved, the liners can be immediately capped, minimizing the loss of VOCs. Unfortunately, without extruding the soil core from the metal liners, detailed

logging of the soil core is not possible. Short liners (4 to 6 inches long) may be useful for providing a minimal amount of lithological information. The soil lithology can be roughly discerned by inspecting the ends of the soil-filled liners; specific liners can then be sealed and submitted for chemical analysis. Extruding soil cores directly into glass jars for chemical analysis should be avoided since up to 90 percent of the VOCs may be lost from the sample (Siegrist, 1990).

Sample Contamination

The potential for sample contamination will depend on both the type of soil sampler and the type of DP rod system. The major concern with nonsealed samplers is that the open bottom may, when used with single-rod systems, allow them to collect soil that has sloughed from an upper section of the probe hole; they, therefore, may collect samples that are not representative of the sampling zone. If the sloughed soil contains contaminants, an incorrect conclusion could be made regarding the presence of contaminants at the target interval. Alternatively, if the overlying soil is less contaminated than the soil in the targeted interval, erroneously low concentrations could be indicated. As a result, nonsealed samplers should not be used with single-rod DP systems where contaminated soils are present. In such cases, piston samplers are the only appropriate soil samplers.

Nonsealed samplers can be safely used with cased DP systems above the water table. When sampling below the water table, particularly through geological formations with a high hydraulic conductivity, nonsealed samplers should not be used because contaminated water can enter the drive casing. In this situation, water-tight piston samplers must be used in combination with cased DP systems. In many low permeability formations, water does not immediately enter the outer drive casing of cased DP systems, even when the casing is driven to depths well below the water table. In these settings the potential for sample contamination is greatly reduced, and nonsealed soil samplers can be lowered through the outer casing. A summary of sealed and nonsealed soil samplers is presented in Exhibit V-6.

Active Soil-Gas Sampling Tools

Chapter IV, Soil-Gas Surveys, discusses the methods, capabilities, and applicabilities of both active and passive soil-gas surveys. Because active soil-gas sampling is performed with DP equipment, the various DP tools used in the collection of active soil-gas samples are covered in this section.

Exhibit V-6
Summary Of Sealed And Nonsealed Soil Sampler Applications

		Single-Rod System		Cased System	
		Nonsealed	Sealed	Nonsealed	Sealed
Sampling Above Watertable	NAPLs Not Present	✓ ¹	✓	✓	✓
	NAPLs Present		✓	✓	✓
Sampling Below Watertable	NAPLs Not Present	✓ ¹	✓	✓	✓
	NAPLs Present		✓	✓ ²	✓

¹ Fine-grained (cohesive) formations where probe hole does not collapse.

² In low permeability soil where groundwater does not enter drive casing.

In active soil-gas sampling, a probe rod is pushed (either manually or mechanically) to a specified depth below the ground surface (bgs) into the vadose zone. A vacuum is applied to the rods (or tubing within the rods), and the sample is collected. The use of probe tips with larger diameters than the probe rods is a practice that should be discouraged when soil-gas sampling. Some DP practitioners use these large tips in order to reduce friction on advancing probe rods and therefore increase depth of penetration. This practice, however, will increase the likelihood of sampling atmospheric gases and diluting constituent concentrations.

There are four variations of soil-gas sampling tools and procedures: expendable tip samplers, retractable tip samplers, exposed samplers, and cased system sampling. Exhibit V-7 presents several soil-gas sampling tools.

Expendable Tip Samplers

Expendable cone-shaped tips, made of either steel or aluminum, are held in a tip holder as the DP rod advances (Exhibit V-7a₁). Once the desired depth has been reached, the DP rods are pulled back a few inches (Exhibit V-7a₂) and the tip can be separated from the tip holder, exposing the soil. Deeper samples can be collected in the same hole by withdrawing the probe and attaching another expendable tip. The previous tip can usually be pushed out of the way in most soils; however, some soils (*e.g.*, dense clays) may prevent the tip from moving and, therefore, prevent re-entry into the same hole.

The advantage of this method is that it allows retraction grouting (discussed in detail on page V-47). The major disadvantage of this method is that collection of deeper soil-gas samples in the same probe hole can be very time consuming because of the need to retract and re-insert the entire probe rod.

Retractable Tip Samplers

Retractable tips are similar to the expendable tips described above, except that the tip is physically attached to the tip holder by a small steel connecting tube (Exhibit V-7b). The connecting tube contains small holes, slots, or screens, and is held within the probe rod until the sampling depth is reached. As with the expendable tip sampler, the probe rod is withdrawn a few inches so that the tip can be dislodged, exposing the connecting tube.

Retractable tip samplers can be used to sample a single probe hole at multiple levels if the formation will not allow an expendable tip to be moved out of the way of the advancing probe rod. Generally, the probe rod should be withdrawn entirely from the probe hole in order to properly secure the tip. The probe rod should not be pushed back over the tip while in the hole because if the tip does not seat properly the assembly will be damaged. A disadvantage of this method is that it does not allow retraction grouting.

Exposed-Screen Samplers

Exposed screen samplers are probe rods that are fitted with slotted or screened terminal ends. They are similar to the exposed-screen samplers described in the groundwater sampling section which follows and which is depicted in Exhibit V-10a (page V-22). They may be made of steel or PVC and are exposed to the subsurface as they are driven to the sampling depth.

The major advantage of this tool is that it allows rapid sampling of multiple intervals within the same probe hole because the probe rod does not need to be retrieved before advancing to the next depth. The primary drawback is that if the slots are exposed to contaminants as the probe is pushed into the subsurface, sample contamination can result. In addition, the slots or screen may become clogged as the probe is pushed through fine grained soils, and retraction grouting can not be used with this method.

Sampling With Cased Systems

Soil-gas sampling can also be accomplished with cased DP systems. Once the sampling depth is reached, samples can be collected either directly through the

outer casing or through disposable tubing (Exhibit V-7c). The major advantages of this method are that it creates less compaction of soils and it enables multiple level sampling. The major disadvantage is that it can be slower than single-rod methods.

Methods For Retrieving Active Soil-Gas Samples

Active soil-gas samples can be retrieved by two methods: soil gas can be drawn directly through the probe rods, or soil gas can be drawn through tubing inside the probe rods. Both methods are available with all the above-mentioned sampling tools.

Sampling Through Probe Rods

Soil gas can be pumped to the surface directly through probe rods, whether single-rod or cased systems. The advantage of this method is that it is relatively simple and less equipment is needed than for sampling through tubing. The drawbacks, however, are significant. First, because the volume of air within the probe rods is large (compared with sampling through tubing), the amount of time needed to purge the rods and collect a representative sample of soil-gas is relatively long. The increased volume of soil gas also increases the chances that short circuiting will occur, resulting in the sampling of atmospheric gases. This issue is particularly a problem with cased systems because the inside diameter of the casing can be much larger than single-rod systems. Second, the joints of most DP rods are not air-tight, so when the rod string is placed under vacuum, soil gas may be drawn from intervals other than the targeted zone.

Sampling Through Tubing

Sampling through tubing (Exhibit V-7d) is a method used to overcome many of the problems associated with sampling directly through the probe rods. The tubing is commonly made of polyethylene (PE) or Teflon[®] (polytetrafluoroethylene [PTFE]). The advantages of this method are that air is not withdrawn from the joints between rod sections, and purge volumes and sampling times are reduced. The disadvantage is that the tubing makes the sampling equipment more complicated and adds an additional expense.

Discussion And Recommendations

In general, sampling soil-gas through PE or PTFE tubing is the preferred method. Sampling directly through the probe rods can be successfully

accomplished, but it requires longer sampling times and investigators must ensure that probe rod joints are completely sealed.

If a soil-gas survey requires multi-level sampling, retraction tip samplers are applicable; however, these samplers require multiple entries into the same probe hole. Exposed screen samplers and cased systems allow for rapid sampling without the problems associated with multiple entry (discussed previously in the *Direct Push Rod System* section). However, exposed samplers may also result in sample contamination if NAPLs are dragged down in the slots or screen.

If soil gas is to be sampled in fine-grained sediments, sampling through tubing should be used to minimize sample volumes and the rod string should be withdrawn a greater distance than normal in order to expose a larger sampling interval. Alternatively, expendable tip samplers and cased systems may be useful if macropores (*e.g.*, root holes, desiccation cracks) exist. These features may be sealed by the advancing probe rod. Expendable tip and cased systems may allow brushes to be inserted into the sampling zone to scour away compacted soil, thus restoring the original permeability. Exhibit V-8 provides a summary of the applicability of the soil-gas sampling tools discussed in this section.

Groundwater Sampling Tools

DP technologies can be used in various ways to collect groundwater samples. Groundwater can be collected during a one-time sampling event in which the sampling tool is withdrawn and the probe hole grouted after a single sample is collected; groundwater sampling tools can be left in the ground for extended periods of time (*e.g.*, days, weeks) to collect multiple samples; or, DP technologies can be used to construct monitoring wells that can be used to collect samples over months or even years.

In general, when the hydraulic conductivity of a formation reaches 10^{-4} cm/second (typical for silts), collection of groundwater samples through one-time sampling events is rarely economical. Instead, collection of groundwater samples requires the installation of monitoring devices that can be left in the ground for days, weeks, or months. In general, however, it is difficult to get an accurate groundwater sample in low permeability formations with any method (whether DP or rotary drilling) because the slow infiltration of groundwater into the sampling zone may cause a significant loss of VOCs. As a result, DP groundwater sampling is most appropriate for sampling in fine sands or coarser sediments.

As with soil-gas sampling, probe tips for one-time groundwater sampling events should not be larger than DP rods because they can create an open annulus

**Exhibit V-8
Summary Of Soil-Gas Sampling Tool Applications**

March 1997

	Sampling Through Probe Rods				Sampling Through Tubing			
	Expendable Tip	Retractable Tip	Exposed Sampler	Cased DP System	Expendable Tip	Retractable Tip	Exposed Sampler	Cased DP System
VOCs less likely to be lost					✓	✓	✓	✓
Sample contamination is less likely	✓	✓		✓	✓	✓		✓
Multi-level sampling	✓	✓	✓ ¹	✓ ¹	✓	✓	✓ ¹	✓ ¹
Minimizes purge volume/sampling time					✓	✓	✓	✓
Allows retraction grouting ²	✓			✓	✓			✓
Macropores may be re-opened in silts and clays	✓			✓	✓			✓

¹ Allows multi-level sampling without removing the tool each time.

² Refer to "Methods For Sealing Direct Push Holes" at the end of the chapter.

V-19

that could allow for contaminant migration. When installing long-term monitoring points, large tips can be used in conjunction with sealing methods that do not allow contaminant migration (*e.g.*, grouting to the surface).

Although most DP groundwater sampling equipment can also be used for determining groundwater gradients, using piezometers (*i.e.*, non-pumping, narrow, short-screened wells used to measure potentiometric pressures, such as the water table elevation) early in a site assessment is typically the best method. Piezometers are quick to install; they are inexpensive to purchase, and, because of their narrow diameter, they are quick to reach equilibrium. DP-installed monitoring wells may also be used for this purpose; however, they are more appropriate for determining groundwater contaminant concentrations once groundwater gradients and site geology have been characterized. Undertaking these activities first greatly simplifies the task of determining contaminant location, depth, and flow direction.

Methods now exist for installing permanent monitoring wells with both single-rod and cased DP systems (Exhibit V-9). These methods allow for the installation of annular seals that isolate the sampling zone. In addition, some methods allow for the installation of fine-grained sand filter packs that can provide samples with low turbidity (although the need for filter packs is an issue of debate among researchers). When samples are turbid, they should not be filtered prior to the constituent extraction process because organic constituents can sorb onto sediment particles. As a result, filtering samples prior to extraction may result in an analytical negative bias. For further information on the need for sediment filtration, refer to Nielsen, 1991.

The following text focuses on the tools used for single-event sampling. These tools can be divided into two groups--exposed-screen samplers and sealed-screen samplers. Exhibit V-10 presents examples of these two groups of groundwater samplers. Exhibit V-10a is a simple exposed-screen sampler; Exhibit V-10b is a common sealed-screen sampler; and Exhibit V-10c is a sealed-screen sampling method used with cased systems. Because new tools are continually being invented, and because of the great variety of equipment currently available, this *Guide* can not provide a detailed description and analysis of all available groundwater sampling tools. Instead, the advantages and limitations of general categories of samplers is discussed.

Exposed-Screen Samplers

Exposed-screen samplers are water sampling tools that have a short (*e.g.*, 6 inches to 3 feet) interval of exposed fine mesh screens, narrow slots, or small holes at the terminal end of the tool. The advantage of the exposed screen is

that it allows multi-level sampling in a single DP hole, without withdrawing the DP rods. The exposed screen, however, also causes some problems that should be recognized and resolved when sampling contaminants. These problems may include:

- Dragging down of NAPLs, contaminated soil, and/or contaminated groundwater in the screen;
- Clogging of exposed screen (by silts and clays) as it passes through sediments;
- The need for significant purging of sampler and/or the sampling zone because of drag down and clogging concerns; and
- Frigility of sampler because of the perforated open area.

There are several varieties of exposed-screen samplers. The simplest exposed-screen sampler is often referred to as a well point (Exhibit V-10a). As groundwater seeps into the well point, samples can be collected with bailers, check-valve pumps (Exhibit V-11), or peristaltic pumps. (Narrow-diameter bladder pumps may also soon be available for use with DP equipment.) Because well points are the simplest exposed-screen sampler, they are affected by all of the above mentioned limitations. As a result, they are more commonly used for water supply systems than groundwater sampling. They should not be used below NAPL or significant soil contamination.

The drive-point profiler is an innovative type of exposed-screen sampler that resolves many of the limitations of well points by pumping deionized water through exposed ports as the probe advances. This feature minimizes clogging of the sampling ports and drag down of contaminants and allows for collection of multiple level, depth-discrete groundwater samples. Once the desired sampling depth is reached, the flow of the pump is reversed, and groundwater samples are extracted. Purging of the system prior to sample collection is important because a small quantity of water is added to the formation. Purging is complete when the electrical conductivity of the extracted groundwater has stabilized. The data provided by these samples can then be used to form a vertical profile of contaminant distributions. Exhibit V-12 provides a schematic drawing of a drive-point profiler. Additional information about a drive-point profiling system is presented in Pitkin, 1994.

Another innovative exposed-screen sampler can be use in conjunction with cone penetrometer testing (CPT). This sampler allows for multi-level sampling by providing a mechanism for *in situ* clearing of clogged screens through the use of a pressurized gas and *in situ* decontamination of the sampling equipment with an inert gas and/or deionized water. Various CPT cones, which allow investigators to determine the soil conditions of the sampling zone, can be used simultaneously with this tool.

Sealed-Screen Samplers

Sealed-screened samplers are groundwater samplers that contain a well screen nested inside a water-tight sealed body. The screen is exposed by retracting the probe rods once the desired sampling depth has been reached. They can be used for collecting accurate, depth-discrete samples. A very common type of sealed-screen sampler is presented in Exhibit V-10b.

The design of sealed-screen samplers is extremely variable. Many are similar to expendable or retractable tip samplers used for soil gas sampling. Some samplers are designed only for a single sampling event; others are designed to be left in the ground for an extended period of time (many weeks or even beyond one year) so that changes in concentrations can be monitored.

The main advantage of this type of sampler is that the well screen is not exposed to soil while the tool is being pushed to the target depth. Thus, the screen cannot become plugged or damaged, and the potential for sample contamination is greatly reduced. O-rings are used to make the sampler water-tight while it is being pushed to the sampling depth. (In order to ensure a water-tight seal, o-rings should be replaced frequently; water tightness can be checked by placing the sealed sampler in a bucket of water.) Sealed-screen samplers are appropriate for the collection of depth-discrete groundwater samples beneath areas with soil contamination in the vadose zone. Because there is no drag-down of contaminants or clogging of the sampling screens, sealed-screen samplers do not require purging.

Some sealed-screen samplers allow sample collection with bailers, check-valve pumps, or peristaltic pumps. (Bladder pumps can also be used with wide diameter cased DP systems.) The quantity of groundwater provided by these samplers is limited only by the hydraulic conductivity of the formation. Other samplers collect groundwater in sealed chambers, *in situ*, which are then raised to the surface. Depending on their design, these samplers may be extremely limited in the quantity of groundwater that they can collect (*e.g.*, 250 ml per sampling event), and they may not collect free product above the water table. If the storage chamber is located above the screen intake, groundwater samples must be collected sufficiently below the water table to create enough hydrostatic pressure to fill the chamber. Only sampling chambers located below the screen intake are, therefore, useful for collecting groundwater or LNAPL samples at or above the water table.

Cased DP systems can also be used as sealed-screen groundwater samplers. After the target zone has been penetrated and the inner rods have been removed, well screen can be lowered through the outer casing to the bottom of the probe hole. The drive casing is then retracted (a few inches to a few feet) exposing the well screen (Exhibit V-10c). This method allows for the collection

of deeper samples by attaching a sealed-screen sampling tool that is pushed into the formation ahead of the tip of the drive casing.

Discussion And Recommendations

Exposed-screen samplers are most appropriate for multi-level sampling in coarse-grained formations (*i.e.*, sediments of fine-grained sands and coarser material). They are typically used in a single sampling event. The major concern with using exposed-screen samplers is that they can cause cross contamination if precautions are not taken (*e.g.*, pumping deionized water through sample collection ports). As a result of these concerns, significant purging of the sampling zone is required.

Sealed-screen samplers are most appropriate for single-depth samples. When they are used in a single sampling event, they are appropriate in formations of fine-grained sands or coarser material because these soils typically allow rapid collection of groundwater. When they are used as either temporary or long-term monitoring wells, they can also be used in formations composed of silts. In addition, because sealed-screen groundwater samplers do not require purging of groundwater, they allow more rapid sampling from a single depth than exposed-screen samplers. Multi-level sampling with sealed-screened samplers is possible with cased and single-rod systems; however, with single-rod systems, the entire rod string must be withdrawn after samples are collected from a given depth. This practice with single-rod systems may create some cross contamination concerns in permeable, contaminated aquifers because the hole remains open between sampling events, allowing migration.

In addition, DP groundwater sampling tools have several advantages over traditional monitoring wells. DP tools allow groundwater samples to be collected more rapidly, at a lower cost, and at depth-discrete intervals. As a result, many more samples can be collected in a short period of time, providing a detailed 3-dimensional characterization of a site. Exhibit V-13 provides a summary of DP sampling tool applications.

General Issues Concerning Groundwater Sampling

There are several issues concerning the collection, analysis and interpretation of groundwater samples that affect both DP equipment and more conventional monitoring wells. Two major issues are the loss of VOCs and the stratification of contaminants.

Exhibit V-13
Summary Of Groundwater Sampling Tool Applications

	Exposed-Screen	Sealed-Screen
Multi-level sampling	✓ ¹	✓ ²
Samples can be collected immediately, little or no purging required		✓ ³
Used to install long-term monitoring point	✓ ⁴	✓
Can be used in formations composed of silts		✓ ⁵
Appropriate below contaminated soil		✓

¹ Cross contamination may be an issue of concern, and purging is required.

² Multi-level sampling without withdrawing all DP rods is only possible with cased DP systems.

³ Collection of a single sample is more rapid with this method.

⁴ One type of exposed-screen sampler (*i.e.*, well points) has been used to install monitoring points, but this method is generally not recommended in zones of NAPL contamination. It may be appropriate at the leading edge of a contaminant groundwater plume.

⁵ Sampling in silts is generally only appropriate when temporary monitoring wells are installed. Significant VOC loss may occur if water flows into sampling point over days, weeks, or months.

Loss Of VOCs

The ability of DP groundwater sampling methods to collect samples equivalent to traditional monitoring wells is a topic of continued debate and research. Loss of VOCs is the most significant groundwater sampling issue. All groundwater sampling methods--including methods used with traditional monitoring wells--can affect VOC concentrations to some degree. The key to preventing the loss of VOCs is to minimize the disturbance of samples and exposure to the atmosphere. Several studies that have compared VOC concentrations of samples collected with DP methods with samples collected by traditional monitoring wells have shown that DP methods compare favorably (Smolley *et al.*, 1991; Zemo, *et al.*, 1994).

Stratification Of Contaminants

Being able to take multiple, depth-discrete groundwater samples with DP equipment is both an advantage and a necessity. At least one recent study has shown that the concentration of organic compounds dissolved in groundwater can vary by several orders of magnitude over vertical distances of just a few centimeters (Cherry, 1994). Because DP sampling tools collect samples from very small intervals (*e.g.*, 6 inches to 3 feet), they may sometimes fail to detect dissolved contamination if the tool is advanced to the wrong depth. Therefore, multiple depths should be sampled to minimize the chances of missing contaminants. At sites with heterogeneous geology, contamination may be particularly stratified. Because the distribution of the contaminants is controlled by the site geology and groundwater flow system, the hydrogeology of the site must be adequately defined before collecting groundwater samples for chemical analysis.

The stratification of contaminants may also result in artificially low analytical results from traditional monitoring wells. These wells are typically screened over many feet (*e.g.*, 5 to 15 feet), while high concentrations of contaminants may be limited to only a few inches (in the case of LNAPLs, typically the top of the aquifer). The process of sampling groundwater, however, may cause the water in the well to be mixed, resulting in a sample that represents an average for the entire screen length (*i.e.*, very high concentrations from a specific zone may be diluted). DP methods avoid this problem by collecting depth-discrete samples.

Conclusion

The practice of collecting groundwater samples both with DP systems and with traditional monitoring wells is a subject of continued research and debate. Both methods can provide high quality groundwater samples for regulatory decisions. Both methods may also provide misleading information if appropriate procedures are not followed and/or if the hydrogeology of a site is not well characterized. Investigators and regulators must be aware of the issues that affect groundwater sample quality and interpretation in order to make appropriate site assessment and corrective action decisions.

***In Situ* Measurements Using Specialized Direct Push Probes**

In addition to collecting samples of soil, soil-gas, and groundwater/NAPL samples, specialized DP probes are also available for collecting *in situ* geophysical, geochemical, and geotechnical measurements of subsurface conditions. Because these methods record vertical profiles, they are often called logging instruments. They provide objective information, but the interpretation of measurements may still be subjective, requiring correlation with actual samples. Information that can be collected with these tools includes stratigraphy, depth to groundwater, approximate hydraulic conductivity, and residual and free product location.

Cone penetrometer testing (CPT) is the most common method for collecting *in situ* measurements. In addition, several recent innovations have adapted some logging methods to other DP rigs. The following section discusses CPT and other logging tools currently available with DP rigs. The growth of this technology is very rapid; there are likely to be many new tools in the near future.

Cone Penetrometer Testing

CPT is a method for characterizing subsurface stratigraphy by testing the response of soil to the force of a penetrating cone. It was developed in the 1920s in Holland by the geotechnical industry and became commercially available in the United States in the early 1970s.

CPT is most commonly performed to depths ranging from 50 to 100 feet; however, depths as great as 300 feet are attainable under ideal conditions (*e.g.*, soft, unconsolidated sediments). Typically, 100 to 300 feet of CPT can be performed per day if the decontamination of probe rods (also referred to as cone rods when used with CPT) and the sealing of holes are necessary; productivity can be doubled when this is not necessary. Production rates can be significantly less if site access is limited or if significant soil, soil-gas, or groundwater sampling is performed.

Traditionally, CPT methods have been used less frequently at sites where investigation depths are less than 40 feet because CPT cones have been pushed with heavy, poorly-maneuverable rigs. Recently, lighter, more maneuverable DP rigs have become available to advance CPT cones. This innovation should make CPT more cost-effective for investigating sites that may have contamination located closer to the surface.

CPT uses sensors mounted in the tip or “cone” of the DP rods to measure the soil’s resistance to penetration. The cone, presented in Exhibit V-14, is pushed through the soil at a constant rate by a hydraulic press mounted in a heavy truck or other heavy weight.

Several types of sensors are commonly available with CPT cones. These include piezometric head transducers (piezocones), resistivity sleeves, nuclear logging tools, and pH indicators. Most recently, CPT cones have incorporated sensors to measure the type and location of petroleum hydrocarbons in the subsurface (*e.g.*, laser induced fluorescence, fuel fluorescence detector). The electronic signals from the sensors are transmitted through electrical cables which run inside the cone rods and to an on-board computer at the ground surface, where they are processed. CPT cones can often measure several parameters simultaneously. An example of a CPT log with multiple parameters is presented in Exhibit V- 15.

DP rigs that perform CPT can also be used to collect soil, soil-gas, and groundwater samples. In fact, some CPT cones allow the collection of soil-gas or groundwater samples without removing the cone from the hole. Collection of soil samples (and in many cases groundwater samples as well) with CPT, however, currently requires the attachment of DP sampling tools in place of the CPT cone. Because removing cone rods and inserting DP sampling tools is time consuming, most CPT contractors will first advance a CPT hole to define the stratigraphy, then advance another DP hole a few feet away to collect soil or groundwater samples.

The following text describes the cones that are available only with CPT and is followed by a section which describes *in situ* logging tools available for both CPT and other DP systems.

Three-Channel Cone

The most common type of CPT cone is referred to as a three-channel cone because it simultaneously measures the tip resistance, sleeve resistance, and inclination of the cone. The ratio of sleeve resistance to tip resistance, which is referred to as the friction ratio, is used to interpret the soil types encountered (Chiang *et al.*, 1992). In general, sandy soils have high tip resistance and low friction ratios, whereas clayey soils have low tip resistance and higher friction ratios. As a result, this information can also be used to estimate the hydraulic conductivity of sediments. With the use of the other CPT channels, stratigraphic layers as thin as 4 inches can be identified.

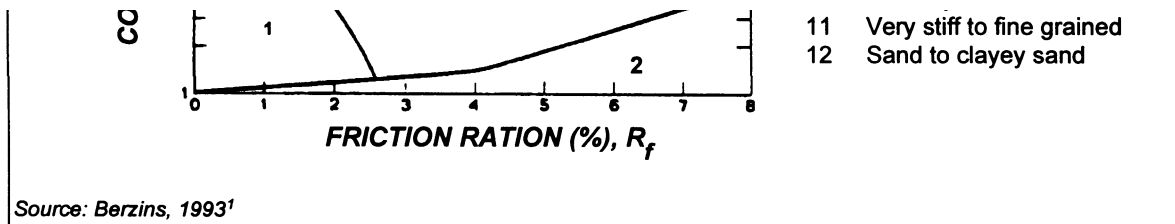

Source: Berzins, 1993¹

¹Reprinted by permission of the National Ground Water Association, Westerville, Ohio. Copyright 1993. All rights reserved.

Three-channel cones record soil behavior rather than actual soil type because in addition to grain size, the soil's degree of sorting, roundness, and mineralogy can also influence tip resistance. As a result, a boring log may help in the interpretation of CPT data for site-specific conditions. In general, soil behavior type correlates well with soil type. An empirically produced plot of friction ratios and soil behavior types is presented in Exhibit V-16.

The inclinometer mounted in the three-channel cone provides a measurement of the inclination of the cone from vertical. Rapid increases in inclination indicate that the rods are bending, allowing the CPT operator to terminate the sounding (*i.e.*, cone penetrometer test) before the cone and/or rods are damaged.

Piezocone

The piezocone is similar to the three-channel cone, described above, except that a pressure transducer is also mounted in the cone (previously presented in Exhibit V-14) in order to measure water pressure under dynamic and static conditions. Pore-pressure dissipation tests can be performed by temporarily halting advancement of the tool and letting the pore pressure reach equilibrium. The slope of a plot of pore pressure versus time is proportional to the permeability of the soil and can be used to estimate hydraulic conductivity and define the water table.

Geophysical And Geochemical Logging Probes

Logging probes are continually being developed for both CPT rigs and other DP probing equipment. The following section describes probes that are available for use with DP technologies in general. Information provided by these probes can be used to interpret site stratigraphy, moisture conditions, and in some cases, contaminant type and distribution.

Conductivity Probes

Conductivity probes measure the electrical conductivity of the subsurface sediments. Conductivity probes are available with CPT probes and, more recently, with small 1-inch diameter DP systems (Christy, 1994). Components of a small-diameter conductivity probe system are depicted in Exhibit V-17.

Because clay units commonly have a greater number of positively charged ions than sand units, clay layers can typically be defined by high conductivity and

Exhibit V-17
Small-Diameter Direct Push Conductivity Probe

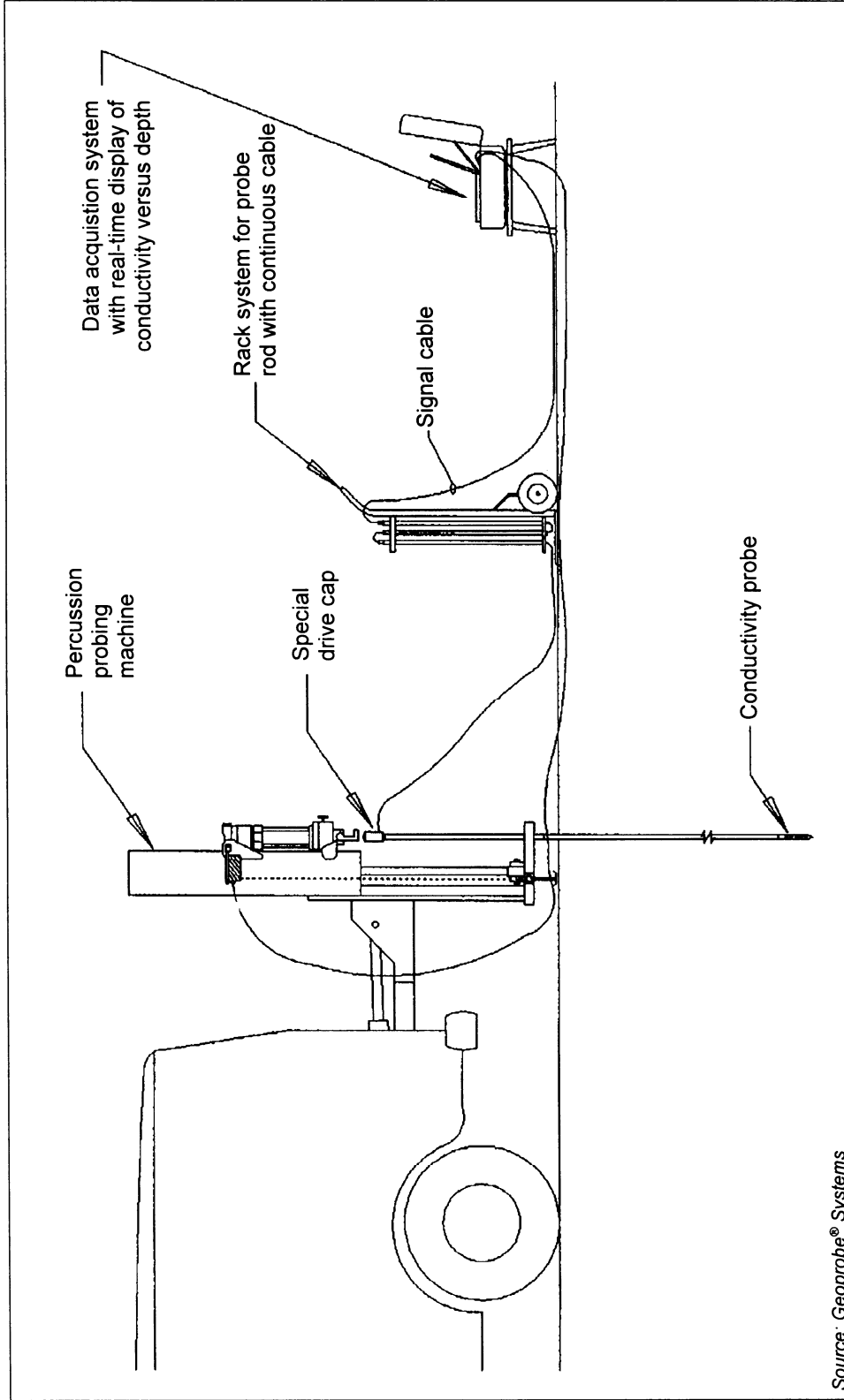

Source: Geoprobe® Systems

sand by low conductivity. These measurements, however, must be correlated with other logging information because conductivity may be the result of other conditions (*e.g.*, moisture content, soil density, mineral content, contaminants). Groundwater tends to increase the electrical conductivity of sediments. Consequently, the zone of saturation may be discernible in logging data if the water table is located in a known resistive layer (*e.g.*, sand) and the contrast is sharp. In a similar way, conductivity measurements may occasionally indicate hydrocarbon contamination if a significant quantity of residual or free product is located in a conductive layer (*e.g.*, clay) because hydrocarbons are resistive (*i.e.*, poorly conductive).

Nuclear Logging Tools

Nuclear logging tools are geophysical instruments that either detect natural radiation of a formation or emit radiation and measure the response of the formation. They have an advantage over other geophysical methods in being able to record usable data through metal casings. Nuclear logging tools can be advanced with DP probes to define the site stratigraphy, groundwater conditions, and, occasionally, subsurface contaminant distribution. They can be used with CPT cones, some small diameter probe rods, and inside of the outer drive casing of cased DP systems. There are primarily three nuclear methods--natural gamma, gamma-gamma, and neutron.

Natural gamma tools log the amount of natural gamma particles emitted by sediments. Because clays typically have a greater number of ions than sands, clays tend to have more radioactive isotopes that emit gamma radiation. By logging the change in gamma radiation, it is often possible to characterize the site stratigraphy. Gamma-gamma tools emit gamma radiation and measure the response of the formation. Because the response is related to the density of the soil, this method can also provide information about the stratigraphy as well as the porosity of soil. Neutron methods emit neutrons into a sediment and measure a response which is dependent on the moisture content. These methods can, therefore, be used to define the water table. In addition, if the stratigraphy and moisture conditions are defined with other methods, neutron logs can indicate the presence and thickness of free-phase petroleum hydrocarbons. A complete discussion of geophysical logging is presented in Keys (1989).

Chemical Sensors

Chemical sensors provide screening level analysis of petroleum hydrocarbons at a specific depth, without removing a soil or groundwater sample. When used over an extended area, they can rapidly provide a 3-dimensional characterization of the contaminant source area. There are several *in situ* chemical

sensors that have recently been developed for use with DP technologies, and more may be available in the near future. Currently available methods are laser-induced fluorescence (LIF), fuel fluorescence detectors (FFD), and semipermeable membrane sensors. These three methods are discussed in more detail in Chapter VI, Field Methods For The Analysis Of Petroleum Hydrocarbon.

Discussion And Recommendations

In situ logging methods are ideal for heterogeneous sites with complex geology because they can rapidly provide continuous profiles of the subsurface stratigraphy. In addition, unlike boring logs, these logging methods provide an independent, objective measurement of the site stratigraphy. When *in situ* logging methods are used in combination with boring logs, data can be used to extrapolate/interpolate geologic units across a site. If boring log information is not available, several *in situ* logging parameters collected simultaneously will often provide similar information.

Investigators should be aware that *in situ* logging methods should generally be calibrated by pushing a probe next to at least one boring that has been continuously cored. In addition, while geophysical logging methods for defining stratigraphy produce reliable information about the primary lithology of the strata, they provide very little data regarding secondary soil features like desiccation cracks, fractures, and root holes. In silts and clays, these secondary soil features (*i.e.*, macropores) may control the movement of contaminants into the subsurface and may greatly influence the options for active remediation. At interbedded sites where defining macropores is important, continuous soil coring may be a better alternative. Exhibit V-18 presents a summary of *in situ* logging equipment used with DP technologies.

Exhibit V-18
Summary Of *In Situ* Logging Equipment
Used With Direct Push Technologies

	DP Method	Application
Three-Channel Cone	CPT Only	Measures tip resistance, sleeve resistance, and inclination. It is used to determine soil behavior types which can be correlated with boring logs.
Piezococone	CPT Only	Measures the rate at which the water pressure returns to static conditions and can be used to estimate hydraulic conductivity and define the water table.
Conductivity Probe	DP	Measures the conductivity of stratigraphic layers and can be used in conjunction with other methods to determine soil type and, sometimes, contaminant location.
Natural Gamma	DP	Measures the natural gamma radiation emitted by a formation and can be used to determine stratigraphy
Gamma-Gamma	DP	Measures the response of a formation to gamma radiation and can be used to determine soil density/porosity.
Neutron Probes	DP	Measures the response of a formation to neutron bombardment and can be used to determine moisture content of soils.
Chemical Sensors	DP	Measures the presence of free or residual product and can be used to delineate source areas.

CPT = Available with cone penetrometer testing equipment only

DP = Available with CPT and other direct push equipment

Equipment For Advancing Direct Push Rods

A few years ago, small-diameter probes were advanced exclusively with manual hammers or rotohammers mounted in light-weight vans, and CPT rods were advanced using heavy (*e.g.*, 20-ton) trucks. Now, contractors mix and match DP rod systems and sampling tools depending on the objectives and scope of the investigation. It is not unusual to see DP rods, sampling tools, and CPT cones being advanced with a wide range of equipment, ranging from small portable rigs to heavy trucks. The following text describes some of the more common methods used to advance DP rods and sampling tools. Drawings of several types of equipment used for advancing DP rods are presented in Exhibit V-19.

Manual Hammers

Manual hammers allow a single operator to advance small-diameter DP rods to shallow depths (Exhibit V-19a). Other names for this type of hammer are “fence post driver” or “slam bar,” since it was adapted from hammers used to drive steel fence posts. Manual hammers are used mostly for driving 0.5- to 1-inch diameter soil-gas sampling tools and are best suited to advancing single DP rods to depths of 5 to 10 feet. The maximum attainable depth with this method is approximately 25 feet. These hammers are the smallest and lightest DP rod advancing equipment weighing between 30 to 60 pounds. As a result, manual hammers are the most portable method available, but they are capable of the least depth of penetration.

Hand-Held Mechanical Hammers

There are two types of hand-held mechanical hammers--jack hammers and rotohammers. Although rotohammers also rotate, they both apply high-frequency percussion to the DP rods, resulting in more rapid penetration and greater sampling depths than manual hammers can attain. Hand-held mechanical hammers are best suited to collecting soil, soil-gas, and groundwater samples using 0.5- to 1-inch diameter equipment. They may also be used to advance small-diameter cased DP rod systems. Typical attainable depth with this method is between 8 and 15 feet, while the maximum depth is approximately 40 feet. This equipment weighs between 30 and 90 pounds and is, therefore, extremely portable.

**Exhibit V-19
Typical Equipment Used To Advance Direct Push Rods**

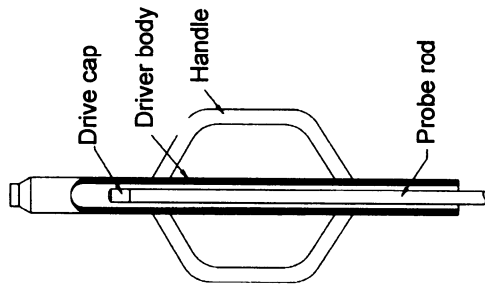

a) Hand held manual hammer

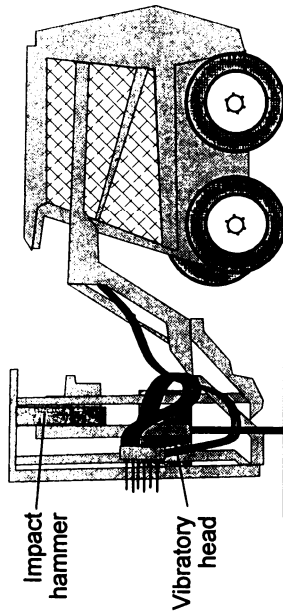

b) Impact hammer and vibratory head mounted on construction vehicle

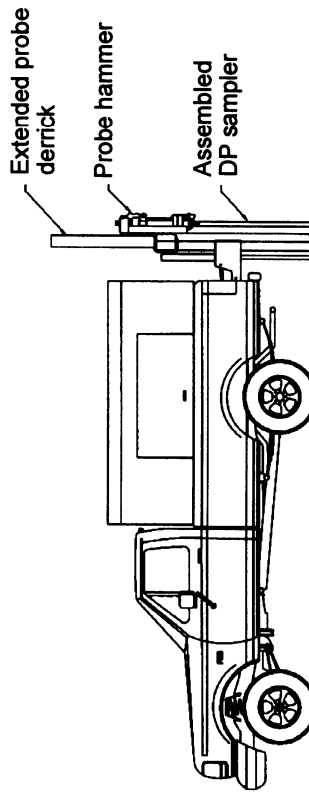

c) Impact hammer mounted on pickup truck

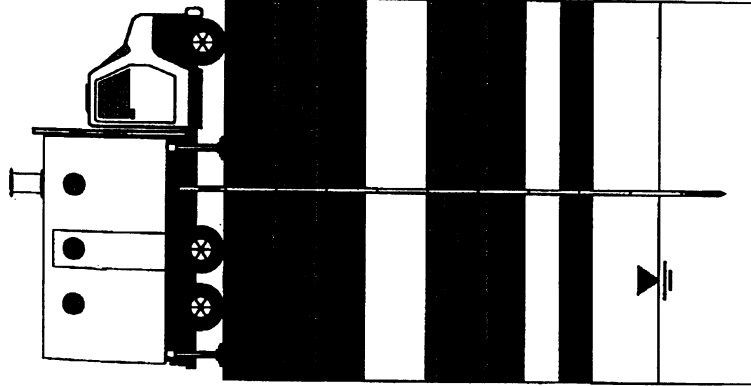

d) DP rods pushed with hydraulic cylinders mounted inside large truck.

Percussion Hammers And/Or Vibratory Heads Mounted On Small Vehicles

The most common methods for advancing DP rods are percussion hammers and vibratory heads mounted on small vehicles (Exhibit V-19b and 19c). Hydraulic cylinders press the rods into the ground with or without pounding or driving. The pounding/driving action is typically provided by hydraulic post-hole drivers or percussion hammers mounted on the vehicle. The hammers pound on a drive head attached to the uppermost DP rod. On some rigs, vibratory heads clamp onto the outside of the DP rods, applying high-frequency vibrations. The vibratory action reduces the side-wall friction, resulting in an increased rate of penetration and greater sampling depths. Some rigs are mounted on trucks, some on vans, yet others on the front of Bobcat[®]-like construction vehicles. These types of rigs can be used to advance single DP rods or cased DP systems. The reactive weight is typically between 5,000 and 17,000 pounds. Depths of 20 to 50 feet are generally attainable, and maximum depths of around 150 feet have been recorded. This equipment is as mobile as the vehicle on which it is mounted.

Small Hydraulic Presses Anchored To The Ground

Small hydraulic presses that are anchored to the ground are fairly light-weight units (200 to 300 pounds) and portable so they can be quickly disassembled and reassembled at new sampling locations. The reactive weight for these rigs is created by the weight of the rig and the pull-down pressure applied against the anchor. On concrete floors, the base plates of the rigs are anchored with concrete bolts or anchoring posts (referred to as “deadmen”) that can be set in pre-drilled holes. On asphalt or open ground, earth augers are spun into the ground to anchor the rigs. Reactive forces as great as 40,000 pounds can be applied with these rigs. Hydraulic cylinders press the DP rods into the ground, usually without percussion hammers. These types of rigs are most commonly used for advancing CPT cones in areas that are difficult to access, but they can also be used to advance other types of DP rods and sampling tools. They can generally attain depths between 20 and 100 feet with a maximum attainable depth of approximately 200 feet.

Conventional Drilling Rigs

Conventional drilling rigs are commonly used to advance soil, soil-gas, and groundwater sampling DP tools inside of hollow-stem augers. In fact, open-barrel and split-barrel samplers have been advanced inside of hollow stem augers to collect soil samples for geotechnical investigations for decades. In geotechnical investigations, the force for advancing these samplers is applied by

striking the DP rods with a 140-pound hammer dropped a distance of 30 inches as described in ASTM D1586 (American Society of Testing and Materials, 1984). In addition, many conventional drill rigs are now equipped with hydraulic percussion hammers to advance the DP sampling tools more rapidly. The reactive weight of conventional drill rigs is between 5,000 and 20,000 pounds. When they are used for DP sampling, they can generally attain depths of 20 to 80 feet with a maximum depth of approximately 200 feet. Because of their size, conventional drill rigs are less maneuverable than construction vehicles.

Trucks Equipped With Hydraulic Presses

Trucks equipped with hydraulic presses are commonly used to advance CPT cones (Exhibit V-19d). Because the force for advancing the rods comes from the weight of the truck, the maximum depth attainable with the DP rods depends on the weight of the truck. Generally, depths of 30 to 100 feet can be obtained; maximum penetration is about 300 feet. Most rigs weigh from 30,000 to 40,000 pounds. Although trucks weighing more than approximately 46,000 pounds are not allowed on public roads, CPT rigs as heavy as 120,000 pounds can be used if weight is added on site. Unlike other DP tools, the force applied to CPT cones is a static push; no pounding or vibration is applied to the rods which could damage the sensitive electrical components and circuitry in the cones.

Hydraulic cylinders mounted inside the trucks apply the static weight of the truck to the DP rods, pushing them into the ground. While designed for CPT applications, these large trucks are equally capable of advancing all other types of DP sampling tools using single-rod or cased DP systems. However, because the rigs were designed primarily for pushing CPT cones, few of them are equipped with hydraulic hammers or vibratory heads.

Discussion And Recommendations

The major differences among the kinds of equipment used to advance DP rods are their depth of penetration and their ability to access areas that are difficult to reach (*e.g.*, off-road, inside buildings). The depth of penetration is controlled primarily by the reactive weight of the equipment although other factors such as the type of hammer used (*e.g.*, vibratory, manual, percussion) can affect the attainable depth. Soil conditions generally affect all DP methods in a similar way. Ideal conditions for all equipment are unconsolidated sediments of clays, silts, and sands. Depending on their quantities and size, coarser sediments (*e.g.*, gravels, cobbles) may pose problems for DP methods. Semi-consolidated and consolidated sediments generally restrict or prevent penetration; however, saprolite (*i.e.*, weathered bedrock) is an exception.

The portability of equipment is controlled by its size and weight. For instance, 20-ton trucks with hydraulic presses would not be appropriate for rough terrain, and conventional drill rigs are often not capable of sampling below fuel dispenser canopies or below electrical power lines. On the other hand, manual hammers or hand-held mechanical hammers are capable of sampling in almost any location, including within buildings. Exhibit V-20 presents a summary of equipment for advancing DP rods.

Exhibit V-20
Summary Of Equipment For Advancing Direct Push Rods

	Reactive Weight (lbs)	Average Attainable Depth (ft)	Maximum Attainable Depth (ft)	Portability
Manual Hammers	30 to 60	5 to 10	25	Excellent
Hand-Held Mechanical Hammers	30 to 90	8 to 15	40	Excellent
Hammers Mounted On Vehicles	5,000 to 17,000	20 to 50	150	Good
Anchored Hydraulic Presses	200 to 40,000	20 to 100	200	Good
Conventional Drill Rig	5,000 to 20,000	20 to 80	200	Poor
Truck With Hydraulic Presses	30,000 to 120,000	30 to 100	300	Poor

Methods For Sealing Direct Push Holes

One of the most important issues to consider when selecting DP equipment is the method for sealing holes. Because any hole can act as a conduit for contaminant migration, proper sealing of holes is essential for ensuring that a site assessment does not contribute to the spread of contaminants. The issue of sealing holes and preventing cross-contamination is not an issue unique to DP technologies. Conventionally drilled holes must also be sealed; in fact, they may pose an even greater risk of cross-contamination because the larger diameter holes provide an even better conduit for contaminants. Many of the recommendations presented here apply to both DP and conventional drilling methods; however, because of the small diameter of DP holes, DP technologies provide some additional challenges.

The selection of appropriate sealing methods depends on site-specific conditions. For example, at sites underlain by homogeneous soil and shallow groundwater, light non-aqueous phase liquids (LNAPLs) released from an UST quickly penetrate the unsaturated soil and come to rest above the water table. Because the LNAPLs are lighter than water, the water table becomes a barrier to continued downward migration. In these settings, DP probe holes pose little risk to the spread of contaminants.

However, at other sites, improperly sealed DP holes can cause significant contaminant migration. For example, at UST sites where there are LNAPLs perched on clay layers in the unsaturated zone, intrusive sampling can facilitate deeper migration of contaminants. In addition, where interbedded formations create multiple aquifers, unsealed holes may allow for the vertical migration of dissolved contaminants into otherwise protected lower aquifers.

The presence of dense non-aqueous phase liquids (DNAPLs) poses an additional risk of cross-contamination. Because DNAPLs are denser than water and typically have low viscosities, they can quickly penetrate soil and migrate below the water table. Although DNAPLs are usually not the primary contaminant at UST sites, they may be present as a result of the use of chlorinated cleaning solvents (*e.g.*, trichloroethylene, methylene chloride). DNAPLs may also be present at refineries and other industrial sites where LUST investigations are performed.

The objective of hole sealing is to prevent preferential migration of contaminants through the probe hole. At a minimum, the vertical permeability of the sealed DP hole should not be any higher than the natural vertical permeability of the geologic formation. In some formations, preferential migration may be prevented without the use of sealants. For example, in heaving, homogeneous

sands, the hole will cave immediately as the probe is withdrawn, thus re-establishing the original permeability of the formation. Or, in some expansive clays, the hole may quickly seal itself. Unfortunately, it is usually impossible to verify that holes have sealed completely with these “natural” methods. As a result, more proactive methods of probe hole sealing are generally necessary.

DP holes are typically sealed with a grout made of a cement and/or bentonite slurry. Dry products (*e.g.*, bentonite granules, chips, pellets) may also be used, but they may pose problems because small granules are typically needed for the small DP holes. These granules absorb moisture quickly and expand, often before reaching the bottom of the hole, resulting in bridging and an incomplete seal. Recent technological innovations are aimed at keeping these granules dry until they reach the bottom of the hole and may help to make the use of dry sealing materials more common with DP holes.

There are four methods for sealing DP holes--surface pouring, re-entry grouting, retraction grouting, and grouting during advancement. The following text summarizes the advantages, limitations, and applicability of these methods. Additional information can be found in Lutenegeger and DeGroot (1995).

Surface Pouring

The simplest method for sealing holes is to pour grout or dry products through a funnel into the boring from the surface after DP rods have been withdrawn (Exhibit V-21a). This method is generally only effective if the hole is shallow (<10 feet), stays open, and does not intersect the water table. Usually, surface pouring should be avoided because the small DP holes commonly cause bridging of grout and dry bentonite products, leaving large open gaps in the hole.

Re-entry Grouting

Re-entry grouting is also a method in which the DP hole is sealed after the DP rods have been withdrawn from the ground. It is used to prevent the bridging of grout and to re-open sections of the hole that may have collapsed. One method is to place a flexible or rigid tube, called a tremie pipe, into the DP hole (Exhibit V-21a), and pump the grout (or pour the dry material) through the tremie pipe, directly into the bottom of the open hole. To ensure a complete seal by preventing bridging, the tremie pipe is kept below the surface of the slurry as the grout fills the hole. However, flexible or rigid tremie pipes may be difficult or impossible to use if the probe hole collapses. The flexible tremie pipe may not be able to penetrate the bridged soil and a rigid tremie may become plugged.

Exhibit V-21 Methods For Sealing Direct Push Holes

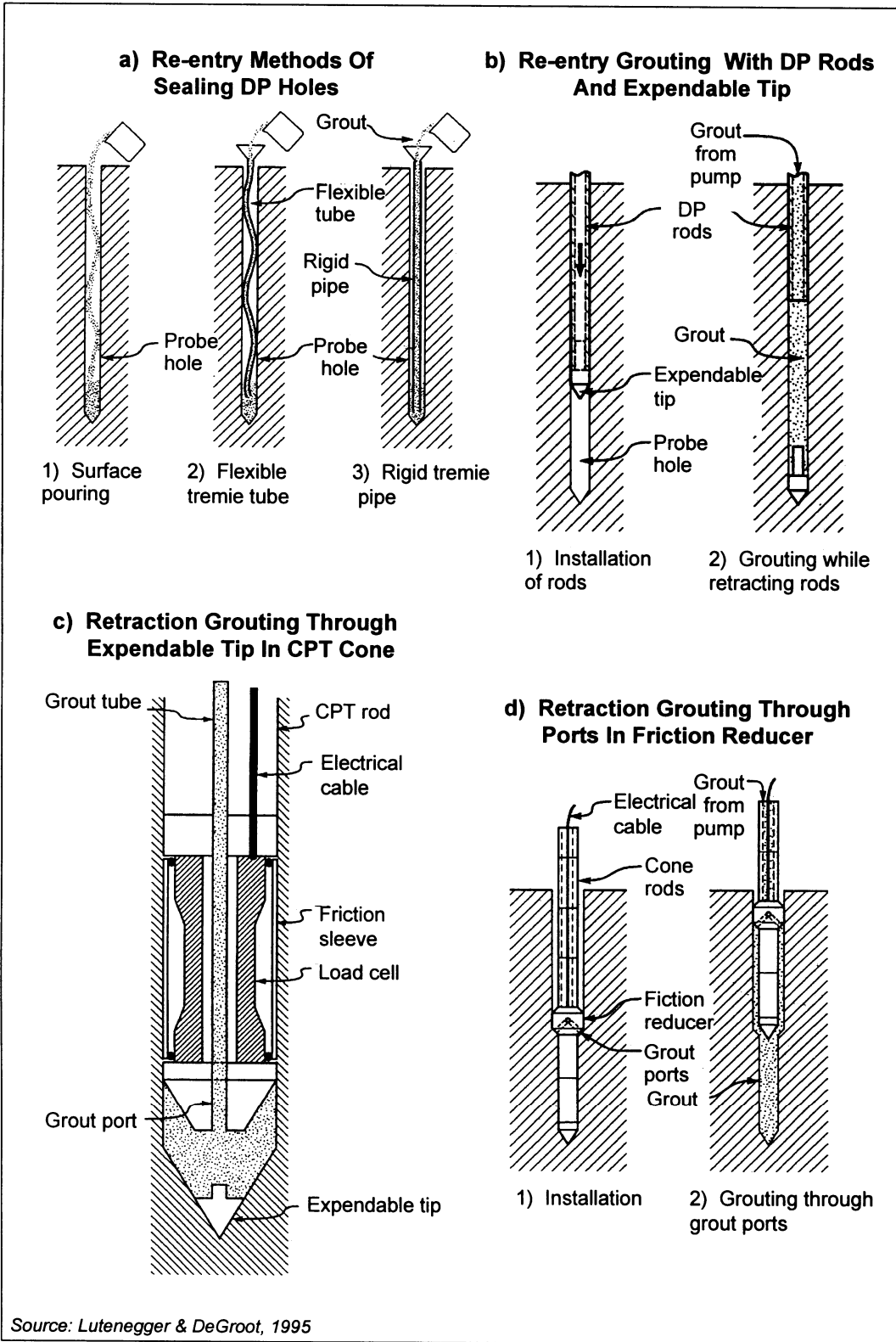

If tremie pipes are not appropriate for sealing DP holes, re-entry with probe rods and an expendable tip may be used (Exhibit V-21b). This method allows the rods to be pushed through soil bridges to the bottom of the probe hole. The probe rods are then withdrawn slightly, and the expendable tip is knocked out (by lowering a small diameter steel rod inside the DP rods) or blown off (by applying pressure with the grout pump). Grout is then pumped through the DP rods as they are withdrawn from the hole.

Re-entry grouting with DP rods and expendable tips usually results in adequate seals; however, this method is not always reliable because, on occasion, DP rods may not follow the original probe hole, but instead create a new hole adjacent to the original one. If this happens, sealing the original hole may be impossible. This situation is rare but may be a problem when sampling:

- Soft silts or clays that overlie a dense layer. In this situation, the clays provide little support and may not guide the rods back to the original hole.
- In cobbly or boulder-rich sediments overlying a clayey confining formation. Here the probe may be deflected, and the underlying clays may not guide the rods into the original hole.
- Loose homogenous sands that overlie a clayey formation. Here the sands may collapse as the rods are withdrawn. Without a hole to guide the rods, the underlying clay may be penetrated in a slightly different location. In these environments, the likelihood of new holes being created with re-entry grouting increases with smaller diameter probe rods and with deeper investigations.

Retraction Grouting

Retraction grouting is a method in which the DP hole is sealed as the DP rods are being withdrawn. The DP rods act as a tremie pipe for grout that is either poured or pumped down the hole, ensuring a complete seal of the probe hole. Retraction grouting can be used with single-rod systems; however, its application is limited by the sampling method. With cased systems, retraction grouting can be used in any situation.

There are two methods for using retraction grouting with single-rod systems. One method can be used when expendable tips or well screens are attached to the probe rod for soil-gas or groundwater sampling. Grouting with these sampling tools occurs as described in re-entry grouting with expendable tips except there is only a single entry, and the sampling tool is also used for grouting. With well screens, the screen must be expendable. With both tools, grout may be poured or pumped into the ground as the rods are retrieved. Other sampling tools

attached to single-rod systems do not allow retraction grouting because the end of the DP rods is sealed by the sampling tools.

Cone penetrometer testing (CPT) allows a second method of retraction grouting with single-rod systems through the use of a small-diameter grout tube that extends from the cone to the ground surface inside the CPT rods. One variation utilizes an expendable tip that is detached from the cone by the pressure of the grout being pumped through the tube (Exhibit V-21c). Another variation of this method consists of pumping the grout through ports in the friction reducer instead of the cone (Exhibit V-21d). Most CPT contractors perform re-entry grouting instead of retraction grouting because the grout tube is very small and subject to frequent plugging.

With cased systems, retraction grouting can be used regardless of the type of sampling tools employed because the outer casing can maintain the integrity of the hole after samples have been collected. As a result, proper use of cased systems can ensure complete sealing of DP holes. This feature is presented in Exhibit V-22.

Grouting During Advancement

Grouting during advancement is a method that utilizes expendable friction reducers (*i.e.*, detachable rings that are fitted onto the DP probe or cone). The space between the probe rod and the hole, created by the friction reducer, is filled with grout that is pumped from the ground surface as the probe rod advances (Exhibit V-23). When the probe rods are withdrawn, the weight of the overlying grout forces the expendable friction reducer to detach. Additional grout is added, while the rods are being withdrawn, to fill the space that was occupied by the rods.

Discussion And Recommendations

Surface pouring can be used in shallow holes (less than 10 feet bgs) that do not penetrate the water table and in which the formation is cohesive. This method is the least favorable and should only rarely be used because the small size of the DP holes increases the probability of grout or dry products bridging and not completely sealing.

Re-entry grouting is the next best alternative and is often adequate for providing a completely sealed hole. Re-entry grouting can be used if deflection of probe rods is not likely, if NAPLs are not present, or if NAPLs are present but do not pose a risk of immediately flowing down the open hole. Because DNAPLs

Exhibit V-22
Sealing Direct Push Holes With Cased Systems

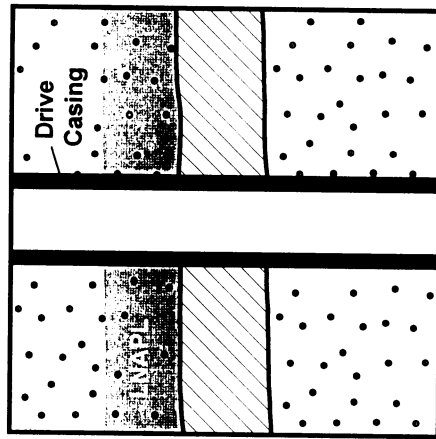

1) With cased systems, steel drive casing is advanced as sampling proceeds. The casing remains in the ground as soil and groundwater samples are retrieved thereby preventing cross-contamination of deeper zones.

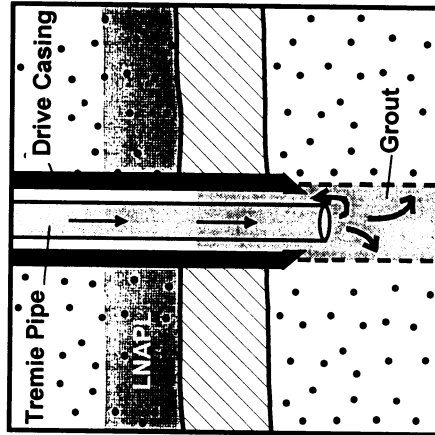

2) After the last sample has been collected, the drive casing is removed. Grout is pumped into the borehole as the casing is withdrawn.

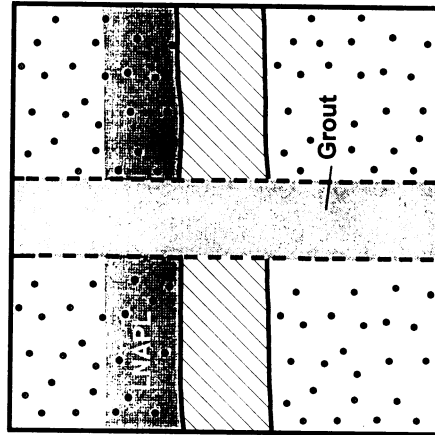

3) Pumping grout as the drive casing is withdrawn ensures that the borehole is properly sealed.

Exhibit V-23
Sealing Direct Push Holes By Grouting During Advancement

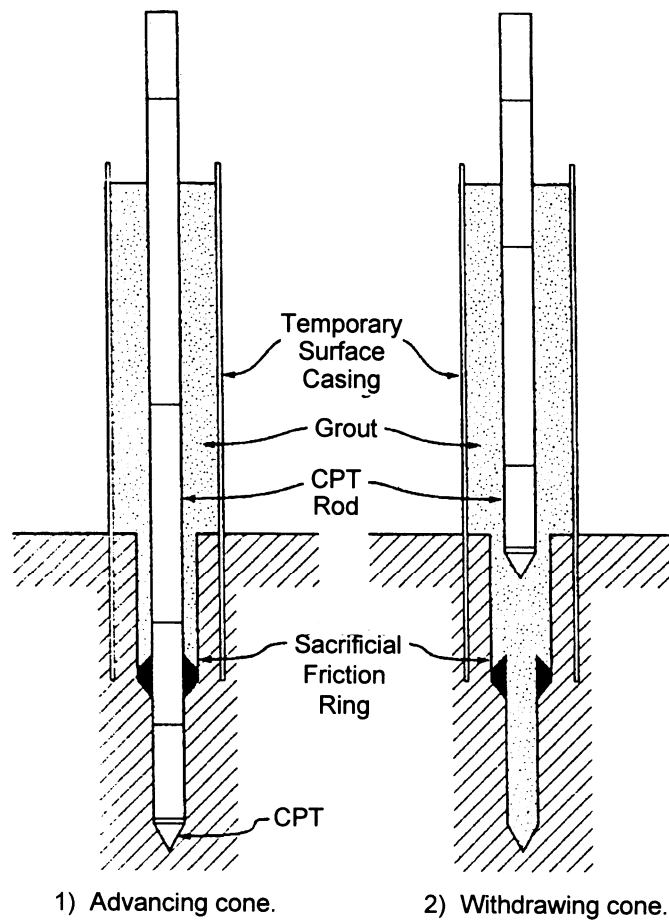

Source: Lutenege & DeGroot, 1995

are denser than water and tend to have low viscosities, they easily overcome the soil pore pressure and, therefore, require retraction grouting or grouting during advancement. If LNAPLs are present the risk of cross-contamination will depend on many other factors (*e.g.*, soil grain size, quantity of LNAPLs). Hence, while re-entry grouting may at times effectively prevent cross-contamination in source areas, it should be used judiciously.

Retraction grouting and grouting during advancement are the most effective sealing methods for preventing cross-contamination. They are required if:

- DNAPLs are present,
- Sufficient LNAPLs are present to rapidly flow down an open hole,
- A perched, contaminated water table is encountered, or
- Deflection of probe rods may occur.

A summary of DP hole sealing methods is presented in Exhibit V-24.

Exhibit V-24
Summary Of Direct Push Hole Sealing Applications

		Surface Pouring ¹	Re-entry Grouting	Retraction Grouting	Grouting During Advancement
NAPLs Not Present	Cohesive Formation	✓	✓	✓	✓
	Formation Collapses		✓	✓	✓
NAPLs Present	Cohesive Formation	✓ ²	✓ ²	✓	✓
	Formation Collapses		✓ ²	✓	✓
Deflection Of Probe Rod May Occur³				✓	✓

¹ This method should not be used if the DP hole intersects the water table.

² These methods may be used if there is not an immediate danger of NAPLs flowing down the open hole (*i.e.*, DNAPLs are not present or large quantities of LNAPLs are not perched on clay layers).

³ There are three conditions when this might occur: Sampling in soft silts or clays that overlie a denser layer; sampling in cobbly or boulder-rich sediments overlying a clayey confining formation; sampling in loose homogenous sands that overlie a confining formation. Note that these situations are not typical. The likelihood of probe deflection increases with depth and decreases with the increase in probe rod diameters.

Direct Push Equipment Manufacturers

A list of DP equipment manufactures is included in Exhibit V-25 and a matrix of equipment is presented in Exhibit V-26. The equipment has not been evaluated by the U.S. EPA and inclusion in this manual in no way constitutes an endorsement. Because of the rapidly changing nature of the DP industry, these tables may quickly become outdated; therefore, readers should not use the tables as their only source of available manufacturers. These vendors are listed solely for the convenience of the reader.

Exhibit V-25 Direct Push Equipment Manufacturers

Art's Manufacturing & Supply 105 Harrison American Falls, ID 83211 (800) 635-7330	Boart/Longyear Company 2340 W. 1700 S. Salt Lake City, UT 84127 (801) 972-1395
Checkwell, Inc. 12 Linden Street Hudson, MA 01749-2045 (508) 562-4300	Christensen Mining Products/Acker P.O. Box 30777 Salt Lake City, UT 84127 (800) 453-8418
Clements Associates Inc. R. R. #1 Box 186 Newton, IA 50208 (515) 792-8285	Concord Environmental Equipment R. R. 1 Box 78 Hawley, MN 56549 (218) 937-5100
Conetec Investigations, Limited 9113 Shaughnessy Vancouver, British Columbia V6P 6R9 Canada (604) 327-4311	Diamond Drilling Contracting Company P. O. Box 11307 Spokane, WA 99211 (800) 325-1563
Diedrich Drill, Inc. P. O. Box 1670 La Porte, IN 46352 (800) 348-8809	Direct Push Technologies, Inc. 605 Alamos Blvd. Seal Beach, CA (310) 430-3326
Foremost Drills/Mobile 1225 64th Ave., N.E. Calgary, Alberta T2E 8K6 Canada (403) 295-5800	Geolnsight 6200 Center St., Ste. 290 Clayton, CA 94517 (510) 672-0919

<p>Geoprobe Systems 601 N. Broadway Salina, KS 67401 (800) 436-7762</p>	<p>Hogentogler & Co., Inc. P. O. Box 2219 Columbia, MD 21045 (800) 638-8582</p>
<p>KVA Analytical Systems P. O. Box 574 Falmouth, MA 02541 (508) 540-0561</p>	<p>Mavrik Environmental & Exploration Products 104 S. Freya Street Suite 218, Lilac Bldg. Spokane, WA 99202 (800) 376-4135</p>
<p>MPI Drilling P. B. Box 2069 Picton, Ontario KOK 2TO Canada (613) 476-5741</p>	<p>Precision Sampling, Inc. 47 Louise Street San Rafael, CA 94901 (800) 671-4744</p>
<p>ProTerra 867 Boston Road Groton, MA 01450 (508) 448-9355</p>	<p>QED Environmental Systems, Inc. 6095 Jackson Road P. O. Box 3726 Ann Arbor, MI 48106 (800) 624-2026</p>
<p>SIMCO Drilling Products Division Box 448 Osceola, IA 50213 (800) 338-9925</p>	<p>SimulProbe Technologies, Inc. 150 Shoreline Highway Bldg. E. Mill Valley, CA 94941 (800) 553-1755</p>
<p>Solinst Canada, Ltd. 35 Todd Road Georgetown, Ontario L7G 4R8 Canada (800)661-2023</p>	<p>Universal Environmental Engineering, Inc. 740 North 9th Ave., Suite E Brighton, CO 80601 (303) 654-0288</p>
<p>Vertek 120A Waterman Road South Royalton, VT 05068 (800) 639-6315</p>	<p>Xitech Instruments, Inc. 300-C Industrial Park Loop Rio Ranch, NM 87124 (505) 867-0008</p>

**Exhibit V-26
Matrix Of Manufacturers And Equipment¹**

Manufacturer	Rod Systems		Sampling Tools			Specialized DP Probes			Equipment to Advance Rods
	Single	Cased	Soil	Soil Gas	Ground-water	CPT	Geophysical Probes	<i>In Situ</i> Chemical Sensors	
Art's Manufacturing & Supply		✓	✓	✓	✓				✓
Boart/Longyear Company			✓						
Checkwell, Inc.	✓		✓	✓	✓				✓
Christensen/Acker			✓						
Clements Associates Inc.	✓		✓						✓
Concord Environmental Equipment	✓		✓	✓	✓				✓
Conetec Investigations, Limited	✓					✓	✓	✓	✓
Diamond Drilling	✓		✓						

Manufacturer	Rod Systems		Sampling Tools			Specialized DP Probes			Equipment to Advance Rods
	Single	Cased	Soil	Soil Gas	Ground-water	CPT	Geophysical Probes	<i>In Situ</i> Chemical Sensors	
Diedrich Drill, Inc.		✓	✓	✓	✓				✓
Direct Push Technologies, Inc.	✓		✓	✓	✓				✓
Foremost Drills/Mobile	✓		✓						
GeoInsight	✓		✓	✓	✓				
Geoprobe Systems	✓		✓	✓	✓		✓	✓	✓
Hogentogler & Co., Inc.	✓		✓	✓	✓	✓	✓	✓	✓
KVA Analytical Systems	✓		✓	✓	✓				✓
Mavrik Environmental			✓	✓	✓				✓
MPI Drilling	✓		✓						✓

Manufacturer	Rod Systems		Sampling Tools			Specialized DP Probes			Equipment to Advance Rods
	Single	Cased	Soil	Soil Gas	Ground-water	CPT	Geophysical Probes	<i>In Situ</i> Chemical Sensors	
Precision Sampling, Inc.	✓	✓	✓	✓	✓				✓
ProTerra	✓		✓	✓	✓				✓
QED Environmental Systems, Inc.			✓	✓	✓	✓			
SIMCO	✓		✓						✓
SimulProbe Technologies, Inc.			✓	✓	✓				
Solinst	✓		✓		✓				
Universal Environmental	✓								✓
Vertek	✓	✓	✓	✓	✓	✓	✓	✓	✓
Xitech	✓			✓					✓

¹ This matrix presents only a general list of the equipment manufactured that is discussed in this chapter. These manufacturers may manufacture other geophysical equipment in addition to what is listed here. In addition, these manufacturers may only supply specialized equipment for the listed methods, and not necessarily all the equipment that is needed.

References

Aller, L., T.W. Bennett, G. Hackett, R. Petty, J. Lehr, H. Sedoris, and D.M. Nielsen. 1991. *Handbook of suggested practices for the design and installation of ground-water monitoring wells*. National Water Well Association, Columbus, OH.

American Petroleum Institute. 1983. *Groundwater monitoring and sample bias*. API Publication 4367. Washington, DC.

Archabal, S.R., J.R. Hicks, and M.C. Reimann. 1995. Application of cone penetrometer technology to subsurface investigation at a solvent-contaminated site. In *Proceedings of the 9th national outdoor action conference*. National Ground Water Association, Columbus, OH.

ASTM. 1984. *Standard test method for penetration test and split-barrel sampling of soil*, D-1586. Annual Book of Standards, Philadelphia.

ASTM. 1994. *Standard test method for deep, quasi-static, cone and friction-cone penetration tests of soil*, D-3441. Annual Book of Standards, Philadelphia.

ASTM. 1995. *Standard test method for performing electronic friction cone and piezocone penetration testing of soils*, D-5778. Annual Book of Standards, Philadelphia.

ASTM (in press). *Draft standard for direct push water sampling for geoenvironmental purposes*. D-6002 ASTM Task Group D-18.21.01, Philadelphia.

ASTM (in press). *Draft standard for direct push sampling in the vadose zone*. ASTM Task Group D-18.21.02, Philadelphia.

ASTM (in press). *Draft standard on cone penetrometer testing for environmental site characterization*. ASTM Task Group D-18.21.01, Philadelphia.

ASTM (in press). *Draft standard on direct push soil sampling*. ASTM Task Group D-18.21, Philadelphia.

Berzins, N.A. 1993. Use of the cone penetration test and BAT groundwater monitoring system to assess deficiencies in monitoring well data. In *Proceedings of the 6th national outdoor action conference*. National Ground Water Association, Columbus, OH.

Cherry, J.A. 1994. Ground water monitoring: some current deficiencies and alternative approaches. *Hazardous waste site investigations: Toward better decisions*. Lewis Publishers.

Chiang, C.Y., K.R. Loos, and R.A. Klopp. 1992. Field determination of geological/chemical properties of an aquifer by cone penetrometry and headspace analysis. *Gr. Water*, vol. 30, no.3: 428-36.

Christy, T.M. 1992. The use of small diameter probing equipment for contaminated site investigation. *Proceedings of the 6th national outdoor action conference*. National Ground Water Association, Columbus, OH.

Christy, C.D., T.M. Christy, and V. Wittig. 1994. A percussion probing tool for the direct sensing of soil conductivity. In *Proceedings of the 8th national outdoor action conference*. National Ground Water Association, Columbus, OH.

Cordry, K.E. 1986. Ground water sampling without wells. In *Proceedings of the sixth national symposium and exposition on aquifer restoration and ground water monitoring*. National Water Well Association, Columbus, OH.

Cordry, K.E., 1995. The powerpunch. In *Proceedings of the 9th national outdoor action conference*. National Ground Water Association, Columbus, OH.

Cronk, G.D., M.A. Vovk. 1993. Conjunctive use of cone penetrometer testing and hydropunch® sampling to evaluate migration of VOCs in groundwater. In *Proceedings of the 7th national outdoor action conference*. National Ground Water Association, Columbus, OH.

Edelman, S. and A. Holguin. 1995. Cone penetrometer testing for characterization and sampling of soil and groundwater. In *Proceedings of the symposium on sampling environmental media*, ASTM Committee D-34. Denver.

Edge, R.W. and K.E. Cordry. 1989. The hydropunch®: An *in situ* sampling tool for collecting ground water from unconsolidated sediments. *Gr. Mon. and Remed.*

Einarson, M.D. 1995. Enviro-Core® — A new vibratory direct-push technology for collecting continuous soil cores. In *Proceedings of the 9th national outdoor action conference*. National Ground Water Association, Columbus, OH.

Fierro, P. and J.E. Mizerany. 1993. Utilization of cone penetrometer technology as a rapid, cost-effective investigative technique. In *Proceedings of the 7th national outdoor action conference*. National Ground Water Association, Columbus, OH.

Keys, W.S. 1989. Borehole geophysics applied to ground-water investigations. In *Proceedings of the 3rd National Outdoor Action Conference*, National Water Well Association, Columbus, OH.

Kimball, C.E. and P. Tardona. 1993. A case history of the use of a cone penetrometer to assess a UST release that occurred on a property that is adjacent to a DNAPL release site. In *Proceedings of the 7th national outdoor action conference*. National Ground Water Association, Columbus, Ohio.

Lutenegger, A.J. and D.J. DeGroot. 1995. Techniques for sealing cone penetrometer holes. *Canadian Geotech. J.* October.

Michalak, P. 1995. A statistical comparison of mobile and fixed laboratory analysis of groundwater samples collected using Geoprobe® direct push sampling technology. In *Proceedings of the 9th national outdoor action conference*. National Ground Water Association, Columbus, OH.

Mines, B.S., J.L. Davidson, D. Bloomquist, and T.B. Stauffer. 1993. Sampling of VOCs with the BAT® ground water sampling system. *Gr. Water Mon. & Remed.*, vol. 13, number 1: 115-120.

Morley, D.P. 1995. Direct push: Proceed with caution. In *Proceeding of the 9th national outdoor action conference*. National Ground Water Association, Columbus, OH.

New Jersey Department of Environmental Protection. 1994. *Alternative ground water sampling techniques guide*. Trenton, 56 p.

Nielsen, D.M. 1991. *Practical handbook of ground water monitoring*. Lewis Publishers.

Pitkin, S., R.A. Ingleton, and J. A. Cherry. 1994. Use of a drive point sampling device for detailed characterization of a PCE plume in a sand aquifer at a dry cleaning facility. In *Proceedings of the 8th national outdoor action conference*. National Ground Water Association, Columbus, OH.

Robertson, P.K. and R.G. Campanella. 1989. *Guidelines for geotechnical design using the cone penetrometer test and CPT with pore pressure measurement*. Hogentogler & Company, Inc., Columbia, MD.

Siegrist, R.L. and P.D. Jenssen. 1990. Evaluation of sampling method effects on volatile organic compound measurements in contaminated soils, *Environ. Sci. and Tech.* vol. 24: 1387-92.

Smolley, M. and J.C. Kappmeyer. 1991. Cone penetrometer tests and hydropunch sampling: A screening technique for plume definition. *Gr. Water Mon. Rev.*, vol. 11, no. 3: 101-6.

Starr, R.C. and R.A. Ingleton. 1992. A new method for collecting core samples without a drill rig. *Gr. Water Mon. Rev.*, vol. 12, no.1: 91-5.

Torstensson, B. 1984. A new system for ground water monitoring. *Gr. Water Mon. Rev.*, vol. 4, no. 4: 131-38.

U.S. EPA. 1993a. *Subsurface characterization and monitoring techniques: A desk reference guide. Volume 1: Solids and groundwater*, EPA/625/R-93/003a. Office of Research and Development, Washington, DC.

U.S. EPA. 1993b. *Subsurface characterization and monitoring techniques: A desk reference guide. Volume 2: The vadose zone, field screening and analytical methods*, EPA/625/R-93/003b. Office of Research and Development, Washington, DC.

U.S. EPA. 1995a. *Rapid optical screen tool (ROST™): Innovative technology evaluation report. Superfund innovative technology evaluation*, EPA/540/R-95/519. Office of Research and Development, Washington, DC.

U.S. EPA. 1995b. *Site characterization analysis penetrometer system (SCAPS): Innovative technology evaluation report. Superfund innovative technology evaluation*, EPA/540/R-95/520. Office of Research and Development, Washington, DC.

U.S. EPA., 1995c. *Ground Water Sampling -- A Workshop Summary*, EPA/600/R-94/205. Office of Research and Development, Washington, DC.

Varljen, M.D. 1993. Combined soil gas and groundwater field screening using the hydropunch and portable gas chromatography. In *Proceedings of the 7th national outdoor action conference*. National Ground Water Association, Columbus, OH.

Zapico, M.M., S.E. Vales, and J.A. Cherry. 1987. A wireline piston core barrel for sampling cohesionless sand and gravel below the water table. *Gr. Water Mon. Rev.*, vol. 7, no. 3: 74-82.

Zemo, D.A., Y.G. Pierce, and J.D. Galinatti. 1994. Cone penetrometer testing and discrete-depth ground water sampling techniques: A cost effective method of site characterization in a multiple-aquifer setting. *Gr. Water Mon. and Remed.* vol. 14, no. 4: 176-82.

Zemo, D.A., T.A. Delfino, J.D. Galinatti, V.A. Baker, and L.R. Hilpert. 1995. Field comparison of analytical results from discrete depth groundwater sampling. *Gr. Water Mon. and Remed.* vol. 15, no. 1: 133-41.

Peer Reviewers

Gilberto Alvarez	U.S. EPA, Region 5
David Ariail	U.S. EPA, Region 4
Jay Auxt	Hogentogler & Company, Inc.
James Butler	Geotech Environmental Equipment, Inc.
Kent Cordry	GeoInsight
Thomas Christy	Geoprobe Systems
Jeffrey Farrar	U.S. Department of Interior, Bureau of Reclamation
John Gregg	Gregg In Situ, Inc.
Blayne Hartman	Transglobal Environmental Geochemistry
Bruce Kjartanson	Iowa State University
Eric Koglin	U.S. EPA, National Exposure Research Laboratory
Patricia Komor	Underground Tank Technology Update
William Kramer	Handex Corporation
Al Liguori	Exxon Research and Engineering Company
David Nielsen	The Nielsen Environmental Field School
Emil Onuschak, Jr.	Delaware Department of Natural Resources and Environment Control
Dan Rooney	Applied Research Associates, Inc. (Vertek)
Charlita Rosal	U.S. EPA, National Exposure Research Laboratory
Katrina Varner	U.S. EPA, National Exposure Research Laboratory