



***Analysis and Report on Sections 4.1 through 4.6 of the Comments of the  
Keweenaw Bay Indian Community (KBIC)—Final***

Prepared for the United States Environmental Protection Agency – Region 5

by The Cadmus Group, Inc. under contract # EP-C-08-015

Region 5 EPA (WU-16J)

September 2009

[www.epa.gov/region5/](http://www.epa.gov/region5/)

## Table of Contents

Table of Contents.....	1
1.0 Introduction.....	2
2.0 Monitoring Wells East and Northeast of the TWIS Area.....	2
3.0 Direction of Ground Water Flow in the TWIS Area.....	3
3.1 Interpretation of Ground Water Flow from Ground Water Elevation Data.....	3
3.2 The Validity of Using Water Levels for Determining Ground Water Flow Direction....	4
4.0 The Continuity of the Transitional Zone and Low Permeability Layers.....	5
4.1 Results from Boring Logs.....	5
4.2 The Nature of Glacial Sediments.....	8
5.0 Properties of Quaternary Deposits.....	8
5.1 Validity of Specific Capacity Test.....	9
5.2 Calculation of Hydraulic Conductivity by Grain Size Analysis.....	10
5.3 Use of Literature Values to Estimate Saturated Hydraulic Conductivity of Lower Permeability Layers in the Unsaturated Zone.....	11
6.0 Unsaturated Flow Modeling Review.....	12
6.1 Model Selection for Unsaturated Analysis.....	13
6.2 Site Characterization and Data Interpretation for Analysis.....	13
6.3 Verification of Numerical Simulations.....	13
6.4 Mass Balance.....	13
6.6 Estimation of the Limiting Hydraulic Conductivity in the Lower Permeability Sediments.....	16
7.0 Conclusions.....	17
References.....	19

## **1.0 Introduction**

The Keweenaw Bay Indian Community (KBIC) submitted a document entitled “Comments of the Keweenaw Bay Indian Community in Opposition to the Issuance of an Underground Injection Control Permit to Kennecott Eagle Minerals Company” (Stratus Consulting, 2009; hereafter referred to as the KBIC Comments) to the U.S. Environmental Protection Agency (EPA) in January, 2009. This report was prepared by KBIC’s consultants, Stratus Consulting Inc. and Integrated Hydro Systems. In light of the concerns raised by the KBIC Comments, EPA has requested that the Cadmus Group, Inc. (Cadmus) evaluate sections 4.1 through 4.6 of the KBIC Comments and re-evaluate the Supplemental Hydrogeologic Study for Groundwater Discharge (North Jackson Company, 2006a) associated with Kennecott Eagle Mineral Company’s (KEMC’s) application for a Treated Water Infiltration System (TWIS) permit. In performing this review, Cadmus has used additional data provided by KEMC to EPA on the geology and hydrogeology associated with the TWIS (KEMC, 2008; KEMC, 2009a; KEMC, 2009b; North Jackson Company, 2008).

For original maps and basic background information, the reader is referred to the Supplemental Hydrogeologic Study for Groundwater Discharge (North Jackson Company, 2006a). Newer maps and ground water level information can be found in the Monitoring Well Installation Report for Groundwater Discharge Permit (North Jackson Company, 2008).

## **2.0 Monitoring Wells East and Northeast of the TWIS Area**

Understanding ground water flow in and down-gradient from the TWIS area is helpful for ground water monitoring planning and for anticipating potential impacts of the TWIS on ground water. The KBIC Comments note that KEMC has not installed monitoring wells in the area down-gradient (northeast, east, and southeast) of the proposed TWIS. Although data from newer wells installed in 2008 (QAL050A, QAL051A/D, QAL052A, QAL053A, QAL055A, QAL056A, and QAL057A/D; see North Jackson Company, 2008, Figure 1 for a map of all wells) have helped to better characterize ground water flow in the immediate TWIS area, there is indeed uncertainty regarding ground water flow downgradient of the proposed TWIS area. To address this uncertainty, the addition of new monitoring wells (for monitoring groundwater level) several hundred feet to the northeast, east, and southeast of the proposed TWIS area will help to establish the details of ground water flow and allow KEMC to identify and respond to any problems as they arise.

The Proposed Monitoring Plan (Foth & Van Dyke, 2007) states that ground water quality sampling will take place at monitoring well QAL031D (in the TWIS area), at QAL026 A/D (upgradient), and at several newer compliance monitoring wells installed near the TWIS (QAL050A, QAL051A, QAL052A, and QAL053A). The newer wells comply with Michigan Department of Environmental Quality (MDEQ) requirements (R 323.2224(1)) in being no more

than 150 feet from the point of discharge of the treated water. Ground water quality sampling at additional monitoring wells, several hundred feet farther downgradient, would provide a more robust plan. Any new wells installed for delineation of ground water flow might be considered for use in routine monitoring of ground water quality as well. After a period of time following the initiation of TWIS operations, during which the initial flow from the WWTP could be expected to approach the perimeter of the TWIS, daily sampling in the monitoring wells could be conducted for one month, followed by monthly monitoring. When there are any indications of a potential problem in the wastewater treatment plant, it would be advisable to return to daily ground water quality monitoring around the perimeter of the TWIS and downgradient until, and for one month subsequent to, the resolution of the problems.

### **3.0 Direction of Ground Water Flow in the TWIS Area**

#### **3.1 Interpretation of Ground Water Flow from Ground Water Elevation Data**

An initial evaluation of the hydrogeologic study by Cadmus had found that available data were insufficient to rigorously characterize ground water flow in the project area (Cadmus, 2008). KEMC has since installed seven new monitoring wells in or very close to the proposed TWIS, for a total of 10 wells in and immediately surrounding the TWIS area (KEMC, 2008). Although these wells do not represent the downgradient area (as discussed above), potentiometric data from these wells have improved the understanding of ground water flow within the TWIS area. KEMC has provided updated groundwater elevation contours in their November 21, 2008 submission (KEMC, 2008).

KEMC's original interpretation of the ground water elevation data defined regional ground water flow toward the northeast (including the TWIS area) (North Jackson Company, 2006a). In contrast, the KBIC Comments interpreted the flow in the TWIS area to be toward the southeast based in part on a localized flow pattern within the TWIS area. The updated ground water head data provided in Figures 2 and 3 in KEMC (2008) are consistent with an overall east/northeast ground water flow direction. There is an area in the northernmost corner of the TWIS within the A (upper) zone that has a flow direction slightly to the southeast (KEMC, 2008). Similarly, the D (lower) zone map reveals a localized area where flow is oriented slightly to the southeast. However, on the whole, the ground water head data indicate an east/northeast flow direction. Additional ground water head data from new monitoring wells located to the east, northeast, and southeast of the TWIS would help to reduce any uncertainty associated with the ground water flow direction.

KEMC provided potentiometric maps in their November 21, 2008 submission (KEMC, 2008). To address concerns regarding ground water flow direction raised by KBIC's consultants, Cadmus conducted a more comprehensive analysis (summarized below) to evaluate KEMC's potentiometric maps. In parts of the TWIS area where no confining layer is present, the A and D

zones can be considered as a single unit. For this reason, wells screened in a single zone in areas with no confining layer would provide data that can be used for either zone. Specifically, wells QAL031D and QAL041D are screened in the D zone; whereas wells QAL050A, QAL052A, QAL053A, and QAL056A are all screened in the A Zone. Because there is no confining layer in the areas of these wells, the water levels measured in these wells apply to both the A and D zone maps. Incorporation of the additional ground water head data into the ground water contour maps further confirms an overall ground water flow direction to the east/northeast.

### **3.2 The Validity of Using Water Levels for Determining Ground Water Flow Direction**

KEMC correctly used water level data measured in monitoring wells to determine ground water flow direction. KBIC's consultants are critical of KEMC for not taking into account faults and dikes in the bedrock and Quaternary deposit thickness for determining ground water flow direction. Specifically, some of the KBIC Comments include the following:

- “KEMC shows bedrock contours extending just north-northeast of the TWIS (Foth & Van Dyke, 2006b, App. B-8, Figure 17). However, no attempt was made to investigate how far this critical structural feature extends north of the Yellow Dog Plains watershed and down into the Negaunee Moraine.” (KBIC Comments, pg. 4-9).
- “In sum, KEMC did not develop realistic alternative conceptual flow models to explain the observed changes in aquifer thickness and structural features in the TWIS area, and instead chose a northeastern groundwater flow direction that is not supported by the available data. More realistic alternative conceptual flow models are discussed in the following section.” (KBIC Comments, pg. 4-23.)

In general, conceptual flow models are used to characterize ground water flow, but they are not capable of addressing or incorporating changes in aquifer thickness or subsurface structural features. The intent of conceptual flow models is to provide an initial representation of ground water flow using general site knowledge. However, given the complexity of a highly heterogeneous subsurface within and immediately around the TWIS area, it is extremely difficult to determine ground water flow direction with any reasonable degree of precision by examining geologic features. Instead, hydrogeologic investigations using hydraulic measurements and mapping of ground water levels are needed to determine flow direction (i.e., to determine the hydraulic gradient based on hydraulic head data points on a “piezometric surface”). Ground water flows from areas of high hydraulic head to areas of low hydraulic head. Any effects of aquifer thickness or other secondary features such as bedrock faults, fractures, or structural elements on ground water levels and flow direction in an aquifer in unconsolidated sediments would already be reflected in the water levels measured in wells and in the resulting calculated flow direction. The measured and mapped ground water head data are the relevant empirical information used to characterize flow. (While useful, conceptual flow models are not as

relevant for defining specific ground water flow details as ground water flow maps based on empirical flow data collected from the site.)

#### **4.0 The Continuity of the Transitional Zone and Low Permeability Layers**

The most recent soil borings and well boring logs presented by KEMC (KEMC, 2009b), when combined with the original borings (North Jackson Company, 2006b), indicated that the clay layer at the TWIS site is discontinuous. This particular issue was discussed in the previous Cadmus report (Cadmus, 2009). A re-examination of both the older and the newer boring logs is conducted by Cadmus here to address a potential concern that either the transitional deposits (B zone) or lower permeability material in the sandy unsaturated zone sediments could cause sufficient mounding for treated wastewater to breach the surface. For mounding to occur, the deposits would have to be both laterally continuous and of sufficiently low hydraulic conductivity. In this section, a weight of evidence approach is used to examine lateral continuity of the lower permeability sediments

#### **4.1 Results from Boring Logs**

To address questions regarding the continuity of low-permeability sediments in the unsaturated zone underlying the TWIS, cross-sections were constructed using logs from soil borings and monitoring wells. These logs provide valuable information on the depth, thickness, and composition of the clay layer, the transitional deposit, and the lower permeability materials in the sandy sediments (e.g., those coded SM – silty sand). Using the program CrossView, stratigraphic data were projected from wells within a distance of 50 feet onto sections E-E' and F-F' (Figures 4-1 and 4-2) in the TWIS area.

Figures 4-1 and 4-2 show that the transitional layer, while present in most of the well and boring logs, does not occur at a consistent depth and is generally quite thin. Such an observation is consistent with the transitional deposit being present as discontinuous lenses and makes any argument for their continuity highly questionable. Silty sand layers (coded SM) in the unsaturated zone are similarly irregular (e.g., occurring at different depths in different logs, and appearing as one layer in some logs and two or three in others) in their appearance across boreholes. It is concluded that the lower permeability sediments are laterally discontinuous and significant mounding of treated wastewater that would breach the land surface is unlikely.

It should be pointed out that when evaluating the appearance of the lower permeability layers in the cross-sections, the subjectivity inherent in boring logs should be kept in mind. The transition between, for example, a sand layer and a silty sand layer may be gradual rather than sharp, and differentiation may be subtle depending on the difference in composition.

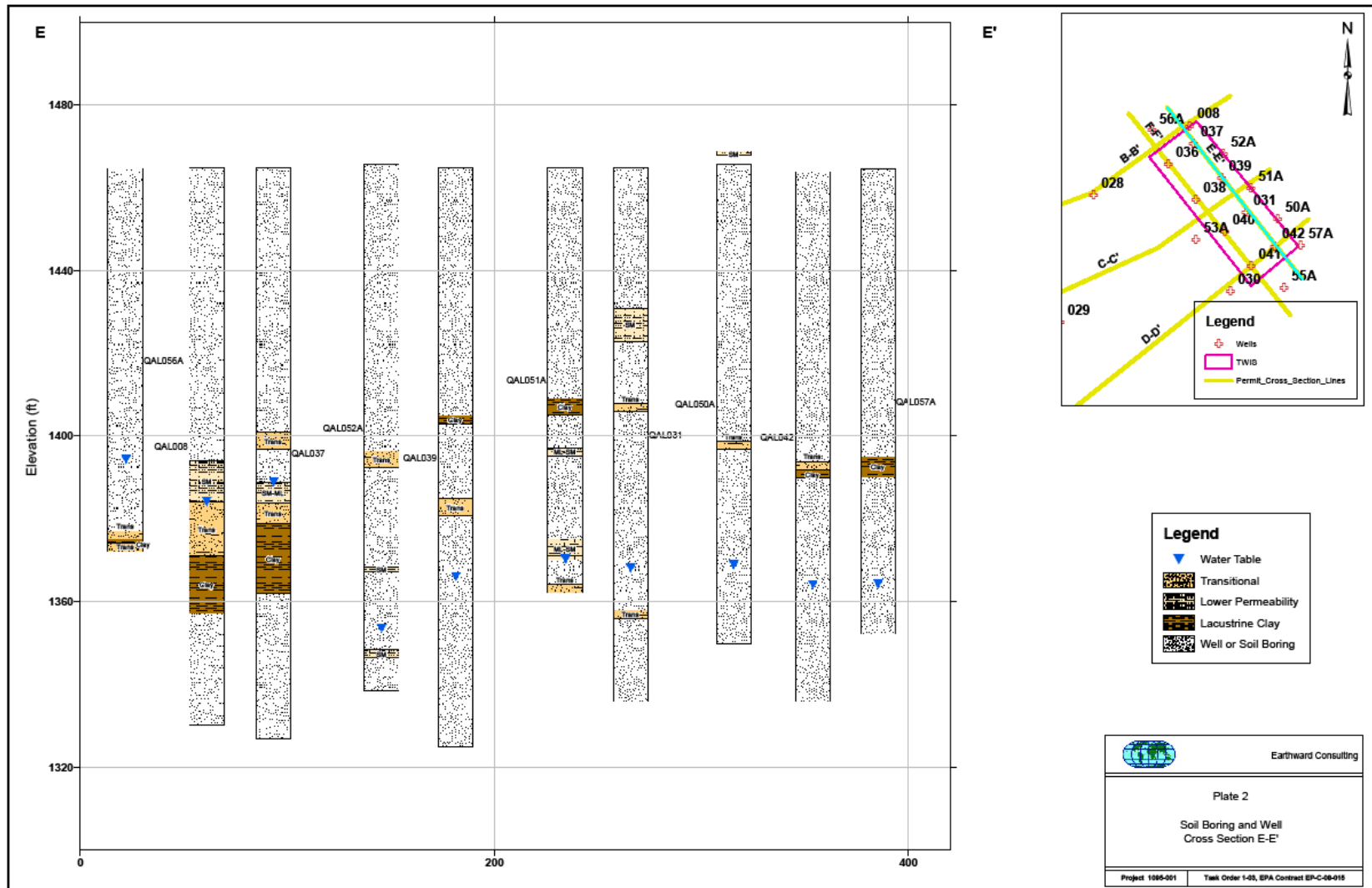

Figure 4-1. Cross section along transect E-E' through TWIS area.

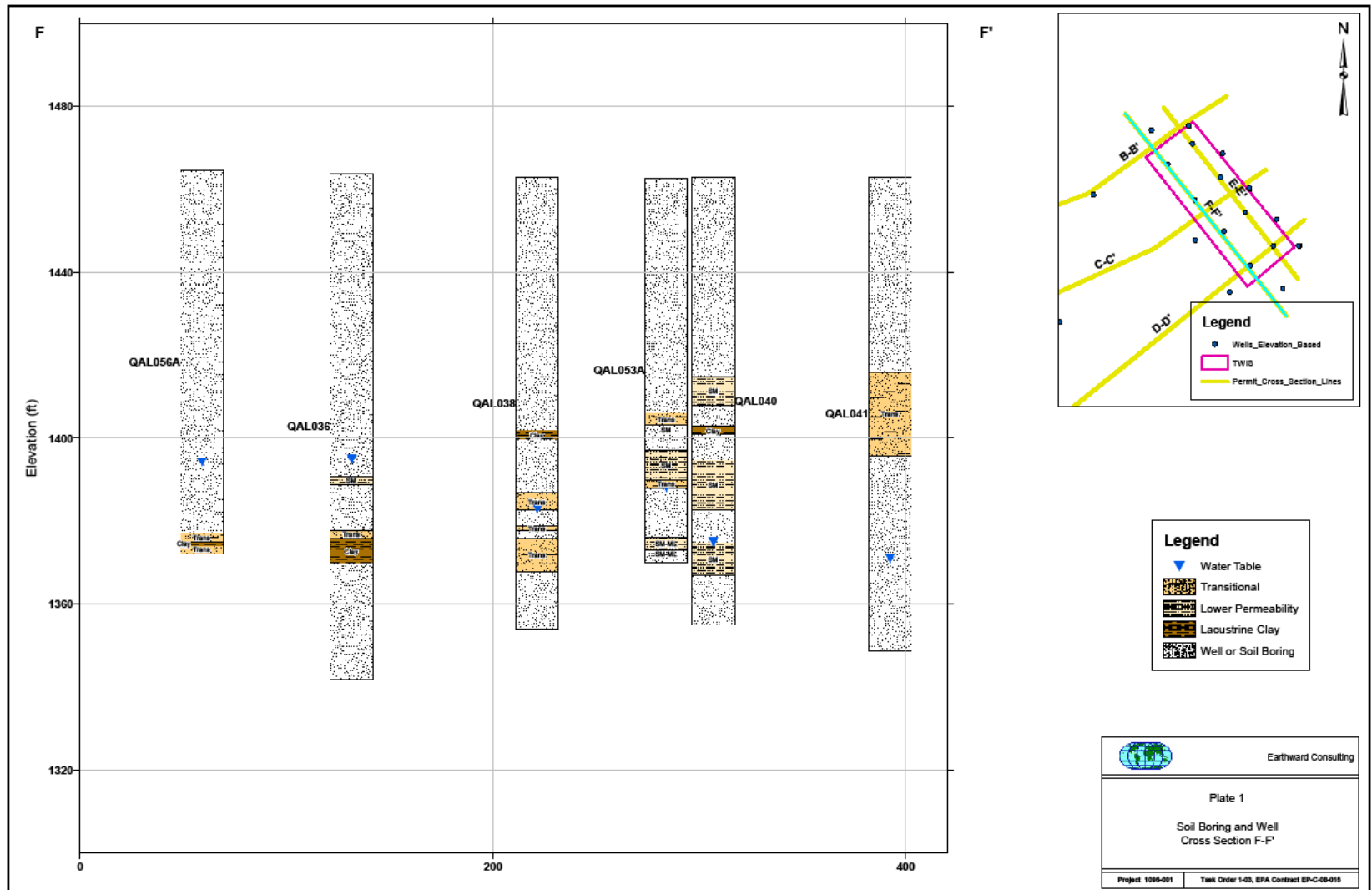

Figure 4-2. Cross section along transect F-F' through the TWIS area.

## **4.2 The Nature of Glacial Sediments**

The inferred depositional environment of the sediments (i.e., a glacial outwash fan) in the TWIS area provides further evidence of their lateral discontinuity. Glacial outwash fans typically have a number of depositional facies. The intermediate zone of an outwash fan, in particular, has a number of braided, shifting channels caused by fluctuating discharges from the glacier (Reading, 1996). The sediments resulting from such glaciofluvial environments are highly heterogeneous, both laterally and vertically, and low permeability sediments are juxtaposed over short distances with high permeability sediments (Webb and Anderson, 1990; Ritzi et al., 1994). The cross-sections for the TWIS area are certainly consistent with such a depositional environment, showing both high and low permeability materials interspersed at a variety of depths. It is unlikely for any low permeability stratum to be continuous over a wide enough area to be of concern with regard to mounding.

## **5.0 Properties of Quaternary Deposits**

A primary criticism by KBIC's consultants of the KEMC application materials is that the sediments in the unsaturated and saturated zones of the TWIS area are poorly characterized with respect to hydraulic properties. The saturated hydraulic conductivity of the sediments would be of a greater concern if there were a continuous low-permeability layer beneath the TWIS. As discussed in Section 4, however, the weight of evidence indicates that low-permeability materials are not continuous beneath the TWIS. Without such continuity, mounding of ground water underneath the TWIS is highly unlikely. Thus, knowledge of the hydraulic conductivity of specific units beneath the TWIS is not crucial to the arguments presented above. Nevertheless, because this issue is given significant attention in the KBIC Comments, several aspects of it are discussed below.

Note: Data are available on the hydraulic properties of the Quaternary deposits, but the data were not all specifically collected from within the TWIS area. A multiple well pumping test was performed on the A and D zones approximately 3,000 feet southwest of the TWIS area. According to North Jackson Company (2006c), the hydraulic conductivity of the B zone transitional deposits (i.e.,  $10^{-3}$  – 1 ft/day) was determined by slug tests, specific capacity tests, and grain size-based calculations, at a distance from the TWIS area (Figure 21 of North Jackson Company, 2006c). As the KBIC Comments note, only a single-well pump test was conducted in the TWIS area. Below is a discussion of the limitations of KEMC's use of the specific capacity test and grain size-based analysis, and on KBIC's consultants' use of literature values for hydraulic conductivity in their analysis.

## 5.1 Validity of Specific Capacity Test

KEMC performed a single-well pumping test in the TWIS area at well QAL031D and used the Cooper-Jacob method to calculate transmissivity. KBIC's consultants stated that the use of this method is inappropriate in the TWIS area because the associated site conditions violate the assumptions behind the Cooper-Jacob method.

The Cooper-Jacob method is based on the Theis (1935) nonequilibrium model of drawdown due to pumping. The Cooper-Jacob method (1946) is a graphical approach that gives an approximate solution to the Theis equation. For results of the Cooper-Jacob method to be valid, the measurements must be taken after the cone of depression has reached a steady state (Fletcher 1997). The pumping test must also comply with the assumptions used by Theis, which include:

- The aquifer is confined.
- The aquifer is homogeneous, isotropic, of uniform thickness, and of infinite areal extent.
- The potentiometric surface is horizontal before pumping.
- The pumping well is of infinitesimal diameter.
- The discharge from the well is constant.
- The aquifer flow conditions to the well are laminar, radial, and horizontal.
- The water pumped from the aquifer is derived from storage within the aquifer and is released instantaneously.

Some of these conditions cannot be or are rarely met in the field (Watson and Burnett, 1993). However, Watson and Burnett (1993) note that "in spite of the relatively substantial deviations from the assumptions listed, the results derived from the Theis equation are most often satisfactory for use in practice" (Watson and Burnett 1993, p. 340). The assumption most pertinent to the results of the test is that the aquifer is confined. Weight et al. (2008) cite a study in which simulations of single-well pumping tests were conducted to determine how Cooper-Jacob results compared with known transmissivities. The study found that the Cooper-Jacob results generally agreed with the known values in situations where the assumptions were not met as long as the aquifer was confined. When the test was carried out for unconfined aquifers, the Cooper-Jacob results consistently overestimated the known value by a factor of two or more. Watson and Burnett (1993) note that in some situations, the Theis method (and thus the Cooper-Jacob method) can be used to analyze unconfined aquifers. The methods can be used as long as pumping drawdown does not exceed 10 percent of the aquifer thickness. If the difference is 10 to 25 percent, a correction factor can be applied, but a difference of over 25 percent, the method cannot be used to analyze the unconfined aquifer.

For the pump test at well QAL031D, the drawdown was approximately 2.35 feet. Saturated aquifer thickness in QAL031D in the sandy sediments is less than 20 feet, resulting in the drawdown being greater than 12% of the saturated thickness (thus exceeding the 10% maximum by which drawdown can exceed aquifer thickness in an unconfined aquifer, for the Theis method

to be accurate). It is not known if a correction factor was applied. Thus, the single well pump test may not be reliable in this setting.

KEMC acknowledges that multiple-well tests are the more reliable method for determining aquifer hydraulic properties. They have attempted to account for this by comparing the results of the multiple-well pumping tests with data from a single-well test (referred to by KEMC as a “specific capacity test”). Data in Figure 32 of the Supplemental Hydrogeologic Study (North Jackson Company, 2006a) compares the hydraulic conductivity for well QAL004D obtained by the multiple-well pumping test with that obtained from a single-well test. The hydraulic conductivity from the single well test was roughly half of that from the multiple-well test. This is not a very large difference in hydraulic conductivity, as it often varies by many orders of magnitude at a single site. Furthermore, Figure 32 in the hydrogeologic study suggests that conductivity estimates for the A and D zones, obtained by different methods and over a large area, are within the same order of magnitude. This indicates general agreement in measured conductivity values at the site.

## **5.2 Calculation of Hydraulic Conductivity by Grain Size Analysis**

The largest number of hydraulic conductivity estimates provided by KEMC were obtained by grain size analysis, including estimates for the outwash sand (A and D zones), lacustrine clay (C zone), and transitional deposits (B zone). This method can be used where field tests are not practical, in situations where only small samples can be obtained, or where sample collection is difficult (Millham and Howes, 1995). The effective diameter (size of the sieve through which 10% of the material will pass) is the parameter most strongly correlated to hydraulic conductivity (Davis, 1989). A variety of methods have been developed, and it is not stated which method was used by KEMC.

Researchers have compared grain size analysis to field pumping tests. While the two methods yield comparable results for medium- to coarse-grained, high-permeability, well sorted sediments (Taylor et al., 1987), estimated hydraulic conductivity can vary by up to three orders of magnitude in situations involving heterogeneous environments, low-permeability, clay-rich sediments, or poorly sorted sediments (Campbell et al., 1990). The glacial deposits at the TWIS site are heterogeneous and contain fine, low-permeability sediments. Thus, the use of grain size-based analyses at this site is not very appropriate and should be approached with caution.

Across many comparative studies, a scale effect has also been reported: grain-size analysis and other laboratory or other small-scale methods consistently yield estimates for hydraulic conductivity that are orders of magnitude smaller than those determined from large-scale pumping tests (Campbell et al., 1990; Taylor et al., 1987). This is because sieving destroys both macro and micro scale structures, such as layering, which might act as preferential flow paths and produce higher hydraulic conductivities in the field. While this may not be important in well-sorted sediments, these features play a key role in determining the hydraulic conductivity of

very fine and poorly sorted sediments. This suggests that determinations of hydraulic conductivity based on grain size methods are especially likely to underestimate the true hydraulic conductivity in sediments that are heterogeneous or contain silt and clay fractions. KEMC's grain size-based estimates for the finer grained transitional deposits and lacustrine clay should be considered with particular caution.

### 5.3 Use of Literature Values to Estimate Saturated Hydraulic Conductivity of Lower Permeability Layers in the Unsaturated Zone.

Without values available for the hydraulic conductivity of the silty sand material underlying the TWIS area, KBIC's consultants selected a value from a hydrogeology textbook (Fetter, 2001) when they conducted their modeling. The value selected was at the lower end of a range of values. This choice was justified by stating that a study by Koltermann and Gorelick (1995) shows that "...only a few percent fines can cause hydraulic conductivity values to be up to five orders of magnitude lower compared to clean sand." Although exploring the conservative end of a range of values is a useful exercise, it is important to consider the entire range of possible values to provide a comprehensive analysis.

The KBIC Comments note that values in Freeze and Cherry (1979) show that silty sand may vary in hydraulic conductivity from sand by four orders of magnitude (Table 5-1). However, the ranges of hydraulic conductivity for sand and silty sand overlap by nearly three orders of magnitude; clean sand and silty sand may have hydraulic conductivities that are similar. Factors such as the percent of silt will affect how much a silty sand will differ from a clean sand.

**Table 5-1. Textbook values of hydraulic conductivity**

<b>Sediment Type</b>	<b>K (cm/s) (Freeze and Cherry, 1979)</b>	<b>K (cm/s) (Fetter, 2001)</b>
Clean sand	From $10^{-4}$ to 1	From $10^{-3}$ to $10^{-1}$
Silty sand	From $10^{-5}$ to about $10^{-1}$	From $10^{-5}$ to $10^{-3}$
Silt, loess	From about $10^{-7}$ to $10^{-3}$	From $10^{-6}$ to $10^{-4}$
Marine clay	From $10^{-10}$ to $10^{-7}$	From $10^{-9}$ to $10^{-6}$

According to the study by Koltermann and Gorelick (1995), the change in hydraulic conductivity predicted with a change in the percent of fines depends on the initial porosity of the coarser grained component, the packing of the grains, and whether the variation in percent fines crosses

a threshold value. The sizes of the coarse fraction (gravel vs. sand) and the fines (silt vs. clay) also affect the hydraulic conductivity. For a gravel or sand mixed with clay, an increase of a few percent fines can in fact decrease hydraulic conductivity by five orders of magnitude. For a fine sand mixed with silt, the difference may only be 0.5 to 2 orders of magnitude.

Table 2 in the Supplemental Hydrogeologic Study (North Jackson Company, 2006a) shows the grain size distributions for the Quaternary deposits. Sediments in both the saturated and unsaturated zones that were coded as SP (clean sand) were predominantly fine sand with 0.3 to 4.4 percent fines (silt + clay). Sediments coded as SM (silty sand) had silt contents up to about 50 percent. According to Koltermann and Gorelick's model (Figure 8 in Koltermann and Gorelick, 1995), a fine sand with about 50% silt would have a saturated hydraulic conductivity roughly one and a half orders of magnitude lower than a fine sand with no silt. This is a rough approximation based on the one study cited by KBIC's consultants. However, it illustrates that the difference in hydraulic conductivities is likely to be less dramatic than was assumed by KBIC's consultants. That is, the silty sand, which the KBIC Comments envision as a continuous low permeability layer that will restrict infiltration and lead to mounding of ground water, may be quite similar in hydraulic properties to the surrounding clean sand, and is thus unlikely to pose any limitations on infiltration capacity beneath the TWIS area. The effect of the assumed hydraulic conductivity of silty sand on the potential for mounding of ground water is evaluated in Section 6.0.

## **6.0 Unsaturated Flow Modeling Review**

This section focuses on the new ground water modeling analysis performed by KBIC's consultants using VS2DI, a two-dimensional numerical model that explicitly includes unsaturated flow characteristics and hypothesized heterogeneity. Unlike the previous, more simplified analysis (Foth and VanDyke, 2006), the numerical model can be used to evaluate the hypothesis that there is a zone of lower permeability soil above the water table. KBIC's consultants applied VS2DI to evaluate the possible implications of a hypothetical continuous clay layer in the unsaturated zone beneath the site, a concern motivated by the claim that the unsaturated zone was not adequately characterized.

As stated in Cadmus' previous review, there is most likely horizontal-to-vertical anisotropy at the site that was not included in the analytical model. It was assumed that the sole purpose of the analytical model was to provide guidance for later development of the more complex numerical model, although this was not explicitly stated. The height and extent of the ground water mound estimated by the analytical model are used to determine the aerial extent of the numerical model.

## **6.1 Model Selection for Unsaturated Analysis**

The VS2DI model (USGS, 2004) was selected by KBIC's consultants because it is freely available, developed and supported by the U.S. Geological Survey, and includes a user-friendly interface and postprocessing utility. The model software package also includes soil characteristic curves, facilitating easy input of typical soil types. This feature allows for simple selection among 17 soils types including the 12 listed by Carsel and Parrish (1988), which are often cited. VS2DI is an excellent choice to address the effects of a possible layer of lower-permeability sediment beneath the TWIS.

## **6.2 Site Characterization and Data Interpretation for Analysis**

Because KBIC's consultants claim that KEMC's hydrogeologic characterization is either inadequate or inaccurate, they have dealt with the uncertainty by approaching their analysis with considerable latitude in the selection of analytical parameters. This is a reasonable approach to selecting a range of inputs for a ground water model.

## **6.3 Verification of Numerical Simulations**

KBIC's consultants provided the results of their numerical simulations and also provided the two data sets used to generate those results. These data sets were used to re-run the simulation and verify the results. The graphics from the post processor shown below (Figure 6-1) match Figure 4.17 in the KBIC Comments. Note that there is a 2,000 day equilibration phase in the model before the 60 days of infiltration are simulated. This equilibration phase simulates the establishment of baseline conditions prior to infiltration.

## **6.4 Mass Balance**

Mass balance should ideally be less than 1%. Although not discussed by the KBIC Comments, these runs experienced mass balance errors of almost 5% (see Figure 6-1). The reason for higher error is most likely the time stepping or convergence control parameter selected. As is, the execution takes hours to run. Because of the strong hydraulic conductivity contrast (over two orders of magnitude), it is unlikely that revisions to achieve a lower mass balance would substantially change the overall model predictions.

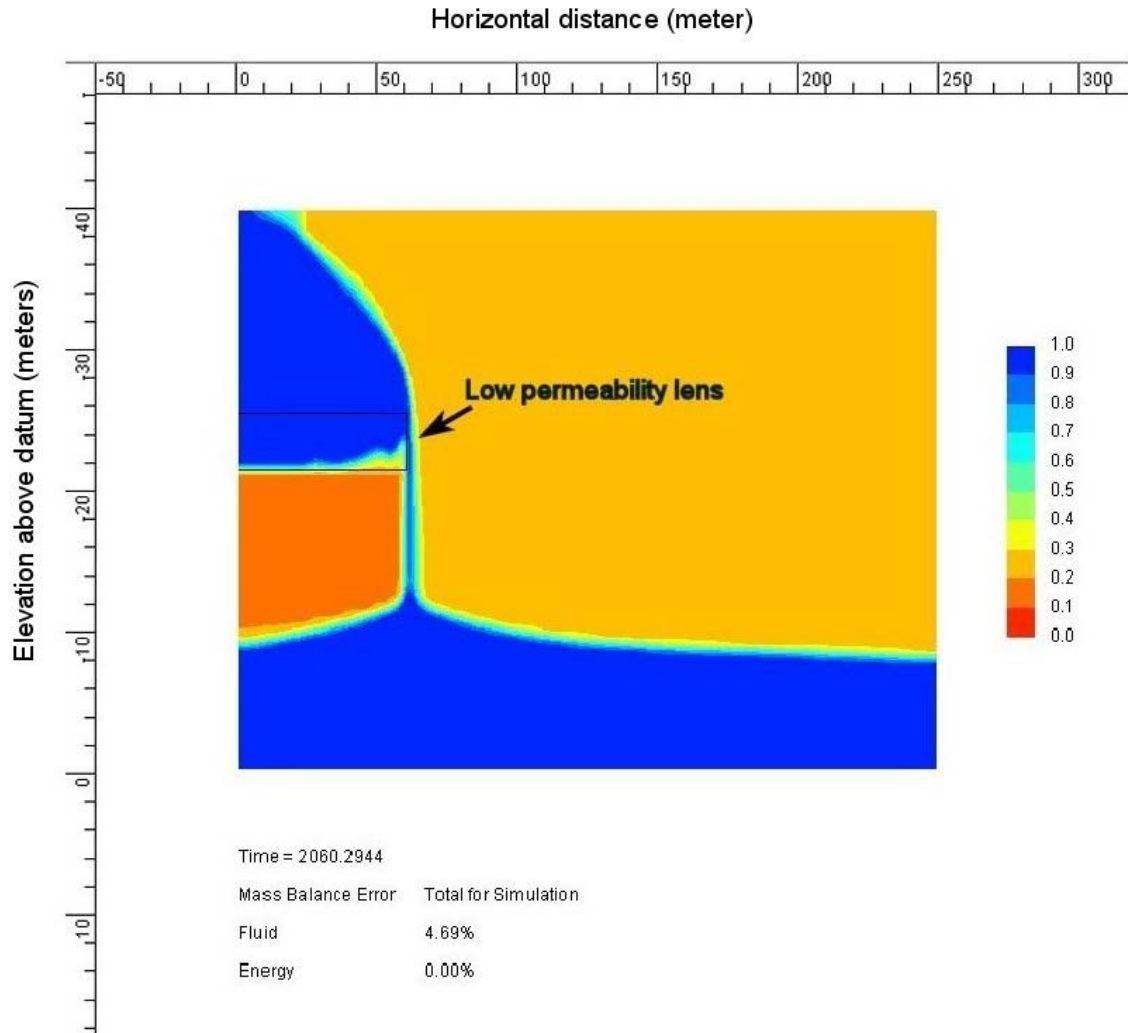

**Figure 6-1. Verification of Simulated Results from KBIC Comments.** Simulation presented here is 60 days of infiltration of TWIS discharge at 400 gpm into a fine sand matrix, with a 60-m long silty sand (SM) lens beneath the TWIS from 48 to 61 ft below ground surface (bgs) (similar to lithology reported in borehole QAL038 (North Jackson Company, 2006b)). Degree of saturation is shown on the colored/numbered scale on the right; darkest blue is fully saturated. Note that the fully saturated zone reaches the surface; that is, there is break-out.

### 6.5 Modification of Infiltration Model Parameter Assumption

The model used by KBIC’s consultants is highly dependent on the assumed saturated conductivity of the silty sand (SM) material as well as the location and thickness of this unit. To demonstrate this, the assumed hydraulic conductivity of the silty sand was changed for this review from 0.009 m/day to 0.225 m/day, a value still within a reasonable range. (The value selected by KBIC’s consultants is the lower limit (0.00864 m/day) as taken from Fetter (2001; Table 4.3 of the KBIC Comments); the upper limit from this same source is 0.864 m/day.) Using

this alternative assumed hydraulic conductivity changes the ratio of the hydraulic conductivities of sand and silty sand from 233 (=2.1/0.009) to 9.3 (=2.1/.225). In the model, this involved selecting a silty loam soil instead of “silt CP” for soil type.

The simulation was re-run with all other parameters unchanged. First, a 2,000 day equilibration period was simulated. Subsequently, infiltration was simulated using the same TWIS recharge rate for a period of 217 days, allowing conditions to stabilize. Unlike the case reported in the KBIC Comments, the results do not exhibit flooding near surface conditions (100% saturation), but rather a 50% saturation as show below (Figure 6-2).

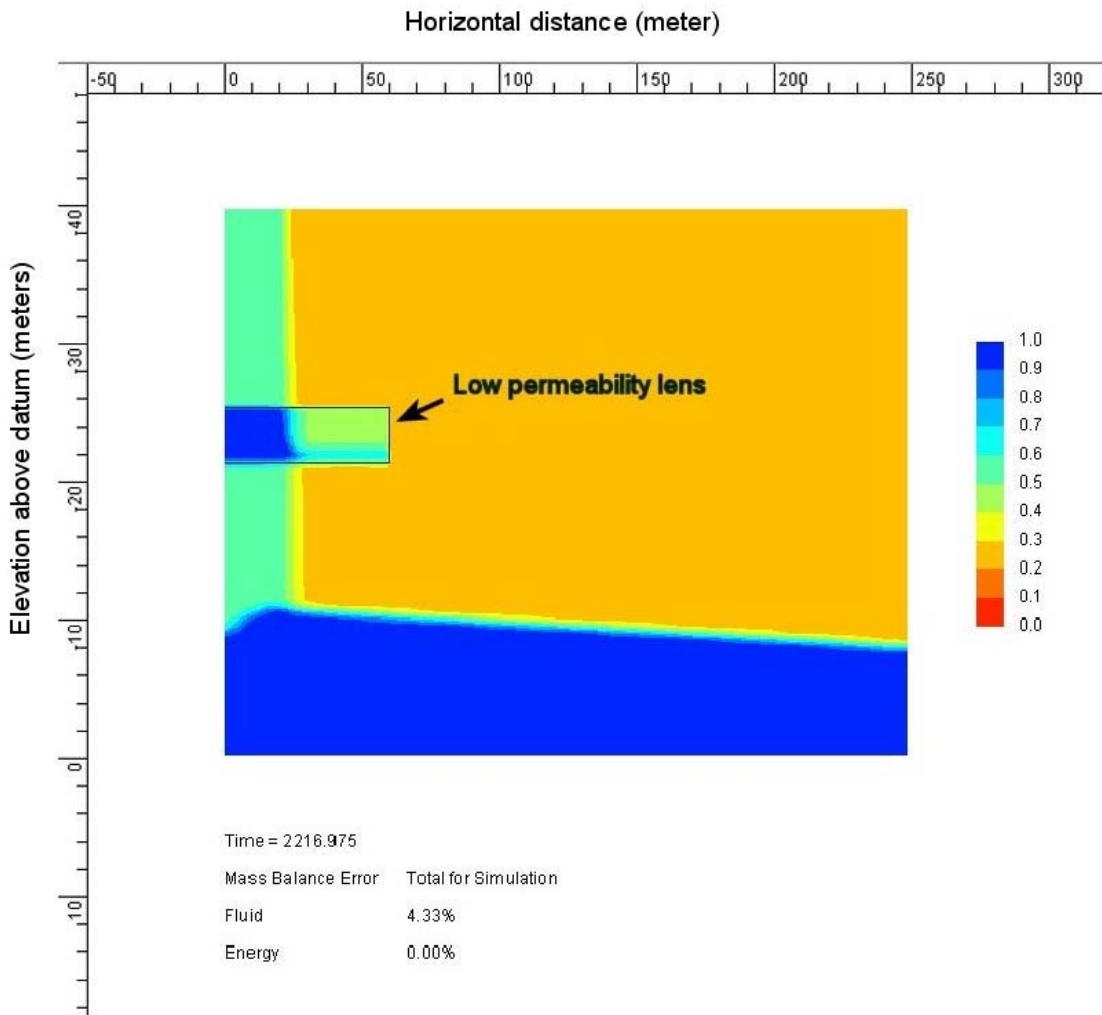

**Figure 6-2. Simulated Results Using Higher Hydraulic Conductivity Lens (Silty Loam).** Results after 217 days of infiltration of TWIS discharge at 400 gpm into a fine sand matrix, with a 60-m long silt loam lens beneath the TWIS from 48 to 61 ft bgs (similar to lithology reported in borehole QAL038). Degree of saturation is shown on colored/numbered scale on the right; darkest blue is fully saturated. Note that at the surface, saturation is only 50%; that is, there is no break-out.

## 6.6 Estimation of the Limiting Hydraulic Conductivity in the Lower Permeability Sediments

Assessment of the hydraulic conductivity value in the lower-permeability sediments that might lead to mounding to the surface can be done based on work by Bower (2002) (Figure 6-3):

$$L_p = i (L_r / K_r)$$

where  $L_p$  is the equilibrium height of a perched mound above the restricting layer,  $L_r$  is the thickness of the restricting layer,  $i$  is the infiltration rate and downward flux through soil and the lower-permeability layer, and  $K_r$  is the hydraulic conductivity of the restricting layer. (Note that the simplified equation here assumes  $i$  is considerably larger than  $K_r$ .)

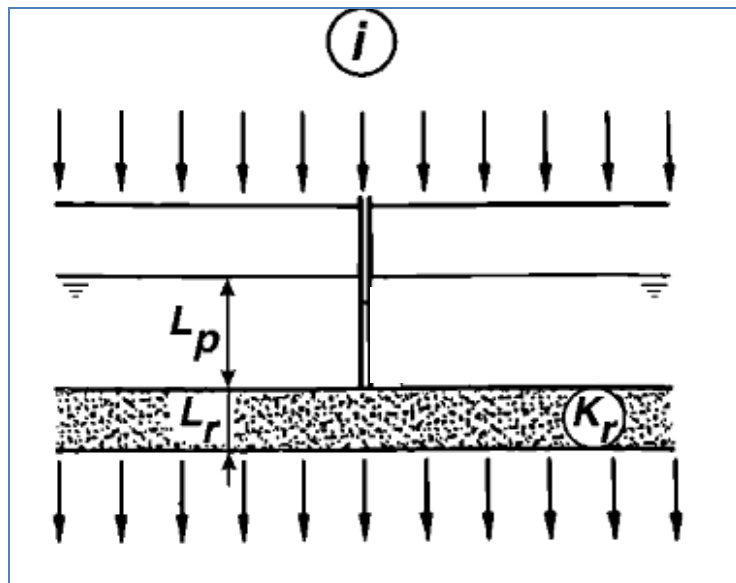

Figure 6-3. Taken from Bower (2002, Figure 10).

Using model parameters from the KBIC Comments and the equation from Bower (2002), the limiting hydraulic conductivity can be calculated (Table 6-1).

**Table 6-1. Parameters for calculation of limiting hydraulic conductivity.**

Parameter	Value	Units
Perched mound above lower permeability layer, $L_p$	45	ft
Thickness of lower-permeability layer, $L_r$	13	ft
Infiltration rate, $V_i$ <i>Assumes 400 gpm</i>	0.629	ft/day
Hydraulic conductivity of lower-permeability layer, $K_r$ <i>Assumes infiltration rate is smaller than <math>K_s</math> (2.1 m/day)</i>	0.182	ft/day

This calculation produces a limiting hydraulic conductivity of 0.18 ft/day. Assuming a 13-foot thick lower-permeability layer, there will only be flooding at the ground surface due to mounding if the hydraulic conductivity of the 13-foot layer is less than 0.18 ft/day (0.06 m/day). This value lies approximately half way between the upper and lower bounds for hydraulic conductivity for silty sand given by Fetter (2001) (Table 5-1), and towards the lower end of the range given by Freeze and Cherry (1979) (Table 5-1). As noted above, Kennecott’s consultants had used the lower bound of Fetter’s values in their modeling. The conclusion that a hydraulic conductivity of 0.18 ft/day could cause mounding to the ground surface also assumes, as stated above, that a lower conductivity layer is continuous. As discussed in previous sections, the genesis of the subsurface sediments at the site and the stratigraphy as described in the boring logs and cross sections strongly suggest that such a continuous layer does not exist in the TWIS area.

## 7.0 Conclusions

The KBIC Comments discussed the geology and hydrogeology at the TWIS site. A review of sections 4.1 through 4.6 of these comments as well as documents and data provided by KEMC indicates that there may be a need for a careful monitoring plan to account for any remaining uncertainty in the characterization of ground water flow direction at the site. Concerns about potential mounding due to a hypothetical continuous low permeability layer appear unwarranted. Specific conclusions are as follows:

- ***Monitoring wells downgradient of the TWIS area.*** A careful monitoring plan that includes areas to the northeast, east, and southeast of the TWIS area would help in the understanding of regional ground water flow and provide timely warning should any problems arise during TWIS operation.
- ***Ground water flow direction.*** There are now 10 monitoring wells within and immediately surrounding the TWIS area. Using ground water elevation data from the monitoring wells to produce potentiometric maps indicates an overall flow direction to the east/northeast.
- ***Lower permeability sediments in the unsaturated zone.*** Low permeability material does not correlate across boreholes, and it is unlikely that any lower permeability strata are continuous over a sufficiently large area to promote mounding of treated wastewater to breach the surface.
- ***Unsaturated zone modeling.*** Modeling of infiltration through the unsaturated zone by KBIC's consultants was done using the lower bound of a range of hydraulic conductivities for a hypothetical silty sand layer. Replication of this modeling using a value for hydraulic conductivity more than an order of magnitude higher (but still within a range of reasonable values) did not produce mounding to the surface. A critical hydraulic conductivity was calculated; a value less than 0.18 ft/day would be required for model-simulated mounding to reach the surface. This value lies approximately half way between the upper and lower bounds for hydraulic conductivity for silty sand given by Fetter (2001) (Table 5-1), and towards the lower end of the range given by Freeze and Cherry (1979) (Table 5-1). Even if a hypothetical silty sand layer with a hydraulic conductivity lower than this critical value were present at the site, for mounding to occur, it would be necessary for such a layer to be fairly thick and continuous. However, as discussed in previous sections, the weight of evidence strongly suggests that such a continuous layer does not exist.

## References

- Bower, 2002. "Artificial recharge of groundwater: hydrogeology and engineering", Hydrogeology Journal, v. 10, p. 121–142.
- Cadmus, 2008. Class V Treated Water Infiltration System Application Review. Submitted to EPA Region 5 on June 12, 2008. [http://www.epa.gov/region5/water/uic/kennecott/pdf/2008-06-12\\_cadmus\\_review.pdf](http://www.epa.gov/region5/water/uic/kennecott/pdf/2008-06-12_cadmus_review.pdf)
- Cadmus, 2009. Comments on Additional Information Related to Class V Treated Water Infiltration System Application. Submitted to EPA Region 5 on June 17, 2009. [http://www.epa.gov/region5/water/uic/kennecott/pdf/2009-06-17\\_cadmus\\_report.pdf](http://www.epa.gov/region5/water/uic/kennecott/pdf/2009-06-17_cadmus_report.pdf)
- Campbell, M.D., M.S. Starrett, J.D. Fowler, and J.J. Klein. 1990. Slug tests and hydraulic conductivity. Ground Water: Prevention, Detection, and Restoration (October 31 – November 2, 1990, Westin Galleria, Houston, Texas [Ground Water Management No. 4]), 85-99.
- Carsel and Parrish, 1988. "Developing joint probability distributions of soil water retention characteristics", Water Resources Research, v. 24, p. 755-769.
- Cooper, H.H., and C.E. Jacob. 1946. A generalized graphical method for evaluating formation constants and summarizing well field history. Transactions of the American Geophysical Union 27: 526-534.
- CrossView. Version 1.1 A-Prime Software; Adobe for ESRI ArcGis. 2008.
- Davis, S. N. 1989. Discussion of "Correlations of permeability and grain size" by Shepherd, R.G. September-October 1989, issue v. 27, no.5 pp, 633-638. Groundwater, 28(1), 116.
- Fetter, C.W., 2001. Applied Hydrogeology, fourth edition. Merrill Publishing Company, Columbus, Ohio.
- Fletcher, F.W. 1997. Basic hydrogeologic methods: A field and laboratory manual with microcomputer applications. Lancaster, Pennsylvania: Technomic Publishing Company, Inc., 310 pages.
- Foth and VanDyke, 2006. Appendix E: Groundwater Modeling of the Treated Water Infiltration System. Prepared for Kennecott Eagle Minerals Corporation. [http://www.epa.gov/r5water/uic/kennecott/pdf/22\\_groundwater\\_model1.pdf](http://www.epa.gov/r5water/uic/kennecott/pdf/22_groundwater_model1.pdf)
- Foth and Van Dyke. 2006b. Eagle Project Mining Permit Application. Prepared for Kennecott Eagle Minerals Company by Foth & Van Dyke and Associates, Inc. February. (Mine Permit Application.) Volumes 1 and 2. Available online at <http://www.deq.state.mi.us/documents/deq-ogs-land-mining-metallicmining-EagleAppWeb.pdf>. Accessed July 29, 2009.

Foth and VanDyke, 2007. Eagle Project Class V Permit Application. Prepared for Kennecott Eagle Minerals Corporation, Appendix F: Proposed Monitoring Plan.  
[http://www.epa.gov/r5water/uic/kennecott/pdf/25\\_monitoring\\_plan.pdf](http://www.epa.gov/r5water/uic/kennecott/pdf/25_monitoring_plan.pdf)

Freeze, R.A., and J.A. Cherry, 1979. Groundwater. Prentice Hall, Upper Saddle River, New Jersey.

KEMC, 2008. Letter to U.S. EPA. Response to EPA's Request for Additional Information, dated October 30, 2008 Kennecott Eagle Minerals Company (KEMC), UIC Permit Application Number MI-103-5W20-0002. [http://www.epa.gov/region5/water/uic/kennecott/pdf/2008-11-21\\_kemc\\_response\\_to\\_rai.pdf](http://www.epa.gov/region5/water/uic/kennecott/pdf/2008-11-21_kemc_response_to_rai.pdf)

KEMC, 2009a. Letter to U.S. EPA. Response to EPA's Request for Additional Information, Submitted on January 13, 2009, Kennecott Eagle Minerals Company (KEMC), UIC Permit Application Number MI-103-5W20-0002.  
[http://www.epa.gov/region5/water/uic/kennecott/pdf/2009-01-22\\_kemc\\_letter.pdf](http://www.epa.gov/region5/water/uic/kennecott/pdf/2009-01-22_kemc_letter.pdf)

KEMC, 2009b (Attachment 2, Appendix A) Soil Boring and Well Construction Report.  
[http://www.epa.gov/region5/water/uic/kennecott/pdf/2008\\_monitoring\\_well\\_installation\\_report\\_a.pdf](http://www.epa.gov/region5/water/uic/kennecott/pdf/2008_monitoring_well_installation_report_a.pdf)

Keweenaw Bay Indian Community (KBIC), Jan 15, 2009. "Comments of the Keweenaw Bay Indian Community in Opposition to the Issuance of an Underground Injection Control Permit to Kennecott Eagle Minerals Company (Application No. MI-103-5W20-0002) Hydrogeologic Modeling in Support of Class V Treated Water Infiltration System Application".

Koltermann, C.E., and S.M. Gorelick. 1995. Fractional packing model for hydraulic conductivity derived from sediment mixtures. Water Resources Research, 31(12), 3283-3297.

Millham, N.P., and B.L. Howes, 1995. A comparison of methods to determine K in a shallow coastal aquifer. Ground Water, 33(1), 49-57.

North Jackson Company, 2006a. Supplemental Hydrogeologic Study for Groundwater Discharge. Prepared for Kennecott Minerals Company. January 2006.  
[http://www.epa.gov/r5water/uic/kennecott/pdf/4\\_hydrogeologic\\_report.pdf](http://www.epa.gov/r5water/uic/kennecott/pdf/4_hydrogeologic_report.pdf).

North Jackson Company, 2006b. Appendix A to Supplemental Hydrogeologic Study for Groundwater Discharge: Monitoring Well Construction Summary and Boring Logs.  
[http://www.epa.gov/r5water/uic/kennecott/pdf/5\\_monitoring\\_well.pdf](http://www.epa.gov/r5water/uic/kennecott/pdf/5_monitoring_well.pdf)

North Jackson Company, 2006c. Comprehensive Summary of Hydrogeologic Reports. Prepared for Kennecott Eagle Minerals Company. February 2006.  
<http://www.deq.state.mi.us/documents/deq-ogs-land-mining-metallicmining-EagleAppWeb.pdf>

North Jackson Company, 2008. Monitoring Well Installation Report for Groundwater Discharge Permit GW1810161. Prepared for Kennecott Eagle Minerals Company, June 2008.

[http://www.epa.gov/region5/water/uic/kennecott/pdf/2008\\_monitoring\\_well\\_installation\\_report.pdf](http://www.epa.gov/region5/water/uic/kennecott/pdf/2008_monitoring_well_installation_report.pdf)

Reading, H.G. 1996. *Sedimentary Environments: Processes, Facies, and Stratigraphy*. Wiley-Blackwell.

Ritzi, R.W., D.F. Jayne, A.J. Zahradnik, A. A. Field, and G.E. Fogg. 1994. Geostatistical modeling of heterogeneity in glaciofluvial, buried-valley aquifers. *Ground Water* 32(4), 666-674.

Stratus Consulting, 2009. *Comments of the Keweenaw Bay Indian Community in Opposition to the Issuance of an Underground Injection Control Permit to Kennecott Eagle Minerals Company (Application No. MI-103-5W20-0002) Prepared for: Keweenaw Bay Indian Community, 16429 Bear Town Road, Baraga, MI 49908.*

Taylor, S.R., G.L. Molyaner, K.W.F. Howard, and R.W.D. Killey. 1987. A comparison of field and laboratory methods for determining contaminant flow parameters. *Ground Water*, 25(3), 321-330.

Theis, C.V. 1935. The relationship between the lowering of the piezometric surface and the rate and duration of discharge from a well using ground-water storage. *Transactions of the American Geophysical Union* 2: 519-524.

USGS, 2004. VS2DI – Version 1.2. A graphical software package for simulating fluid flow and solute or energy transport in variably saturated porous media. Available: [http://wwwbrr.cr.usgs.gov/projects/GW\\_Unsat/vs2di1.2/](http://wwwbrr.cr.usgs.gov/projects/GW_Unsat/vs2di1.2/).

Watson, I., and A.D. Burnett. 1993. *Hydrology: An environmental approach*. Boca Raton, Florida: CRC Press, LLC, 722 pages.

Webb, E.K. & M.P. Anderson. 1990. Using a Sedimentary Depositional Model to Simulate Heterogeneity in Glaciofluvial Sediments. *Proceedings of the Fifth Canadian/American Conference on Hydrogeology: Parameter Identification and Estimation from Aquifer and Reservoir Characterization*. September 18-20, 1990. Banff, Alberta, Canada: pp 23-41.

Weight, W.D. 2008. *Hydrogeology Field Manual*, 2<sup>nd</sup> Edition. New York, New York: McGraw-Hill Professional, 751 pages.