CHAPTER 3: Management Measures for Forestry

I. INTRODUCTION

A. What "Management Measures" Are

This chapter specifies management measures to protect coastal waters from silvicultural sources of nonpoint pollution. "Management measures" are defined in section 6217 of the Coastal Zone Act Reauthorization Amendments of 1990 (CZARA) as economically achievable measures to control the addition of pollutants to our coastal waters, which reflect the greatest degree of pollutant reduction achievable through the application of the best available nonpoint pollution control practices, technologies, processes, siting criteria, operating methods, or other alternatives.

These management measures will be incorporated by States into their coastal nonpoint programs, which under CZARA are to provide for the implementation of management measures that are "in conformity" with this guidance. Under CZARA, States are subject to a number of requirements as they develop and implement their Coastal Nonpoint Pollution Control Programs in conformity with this guidance and will have some flexibility in doing so. The application of these management measures by States to activities causing nonpoint pollution is described more fully in *Coastal Nonpoint Pollution Control Program: Program Development and Approval Guidance*, published jointly by the U.S. Environmental Protection Agency (EPA) and the National Oceanic and Atmospheric Administration (NOAA).

B. What "Management Practices" Are

In addition to specifying management *measures*, this chapter also lists and describes management *practices* for illustrative purposes only. While State programs are required to specify management *measures* in conformity with this guidance, States programs need not specify or require implementation of the particular management *practices* described in this document. However, as a practical matter, EPA anticipates that the management measures generally will be implemented by applying one or more management practices appropriate to the site, location, type of operation, and climate. The practices listed in this document have been found by EPA to be representative of the types of practices that can be applied successfully to achieve the management measures. EPA has also used some of these practices, or appropriate combinations of these practices, as a basis for estimating the effectiveness, costs, and economic impacts of achieving the management measures. (Economic impacts of the management measures are addressed in a separate document entitled *Economic Impacts of EPA Guidance Specifying Management Measures for Sources of Nonpoint Pollution in Coastal Waters*.)

EPA recognizes that there is often site-specific, regional, and national variability in the selection of appropriate practices, as well as in the design constraints and pollution control effectiveness of practices. The list of practices for each management measure is not all-inclusive and does not preclude States or local agencies from using other technically sound practices. In all cases, however, the practice or set of practices chosen by a State needs to achieve the management measure.

C. Scope of This Chapter

This chapter contains 10 management measures that address various phases of forestry operations relevant to the control of sources of silvicultural nonpoint pollution that affect coastal waters. A separate measure for forestry operations in forested wetlands is included. These measures are:

- (1) Preharvest planning
- (2) Streamside management areas
- (3) Road construction/reconstruction
- (4) Road management
- (5) Timber harvesting
- (6) Site preparation and forest regeneration
- (7) Fire management
- (8) Revegetation of disturbed areas
- (9) Forest chemical management
- (10) Wetland forest management

Each of these topics is addressed in a separate section of this chapter. Each section contains (1) the management measure; (2) an applicability statement that describes, when appropriate, specific activities and locations for which the measure is suitable; (3) a description of the management measure's purpose; (4) the rationale for the management measure's selection; (5) information on the effectiveness of the management measure and/or of practices to achieve the measure; (6) information on management practices that are suitable, either alone or in combination with other practices, to achieve the management measure; and (7) information on costs of the measure and/or of practices to achieve the measure.

Coordination of Measures

The management measures developed for silviculture are to be used as an overall system of measures to address nonpoint source (NPS) pollution sources on any given site. In most cases, not all the measures will be needed to address the NPS sources of a specific site. For example, many silvicultural systems do not require road construction as part of the operation and would not need to be concerned with the management measure that addresses road construction. By the same token, many silvicultural systems do not use prescribed fire and would not need to use the fire management measure.

Most forestry operations will have more than one phase of operation that needs to be addressed and will need to employ two or more of the measures to address the multiple sources. Where more than one phase exists, the application of the measures needs to be coordinated to produce an overall system that adequately addresses all sources for the site and does not cause unnecessary expenditure of resources on the site.

Since the silvicultural management measures developed for the CZARA are, for the most part, a system of practices that are commonly used and recommended by States and the U.S. Forest Service in guidance or rules for forestry-related nonpoint source pollution, there are many forestry operations for which practices or systems of practices have already been implemented. Many of these operations may already achieve the measures needed for the nonpoint sources on them. For cases where existing source control is inadequate, it may be necessary to add only one or two more practices to achieve the measure. Existing NPS progress must be recognized and appropriate credit given to the accomplishment of our common goal to control NPS pollution. There is no need to spend additional resources for a practice that is already in existence and operational. Existing practices, plans, and systems should be viewed as building blocks for these management measures and may need no additional improvement.

D. Relationship of This Chapter to Other Chapters and to Other EPA Documents

1. Chapter 1 of this document contains detailed information on the legislative background for this guidance, the process used by EPA to develop this guidance, and the technical approach used by EPA in the guidance.
2. Chapter 7 of this document contains management measures to protect wetlands and riparian areas that serve a nonpoint source pollution abatement function. These measures apply to a broad variety of nonpoint sources; however, the measures for wetlands described in Chapter 7 are not intended to address silvicultural sources.

Practices for normal silvicultural operations in forested wetlands are covered in Management Measure J of Chapter 3.

3. Chapter 8 of this document contains information on recommended monitoring techniques to (1) ensure proper implementation, operation, and maintenance of the management measures and (2) assess over time the success of the measures in reducing pollution loads and improving water quality.
4. EPA has separately published a document entitled *Economic Impacts of EPA Guidance Specifying Management Measures for Sources of Nonpoint Pollution in Coastal Waters*.
5. NOAA and EPA have jointly published guidance entitled *Coastal Nonpoint Pollution Control Program: Program Development and Approval Guidance*. This guidance contains details on how State coastal nonpoint pollution control programs are to be developed by States and approved by NOAA and EPA. It includes guidance on:
 - The basis and process for EPA/NOAA approval of State Coastal Nonpoint Pollution Control Programs;
 - How NOAA and EPA expect State programs to specify management measures "in conformity" with this management measures guidance;
 - How States may target sources in implementing their Coastal Nonpoint Pollution Control Programs;
 - Changes in State coastal boundaries; and
 - Requirements concerning how States are to implement Coastal Nonpoint Pollution Control Programs.

E. Background

The effects of forestry activities on water quality have been widely studied, and the need for management measures and practices to prevent silvicultural contributions to water pollution has been recognized by all States with significant forestry activities. Silvicultural activities have been identified as nonpoint sources in coastal area water quality assessments and control programs. Water quality concerns related to forestry were addressed in the 1972 Federal Water Pollution Control Act Amendments and later, more comprehensively, as nonpoint sources under section 208 of the 1977 Clean Water Act and section 319 of the 1987 Water Quality Act. On a national level, silviculture contributes approximately 3 to 9 percent of nonpoint source pollution to the Nation's waters (Neary et al., 1989; USEPA, 1992a). Local impacts of timber harvesting and road construction on water quality can be severe, especially in smaller headwater streams (Brown, 1985; Coats and Miller, 1981; Pardo, 1980). Megahan (1986) reviewed several studies on forest land erosion and concluded that surface erosion rates on roads often equaled or exceeded erosion reported for severely eroding agricultural lands. These effects are of greatest concern where silvicultural activity occurs in high-quality watershed areas that provide municipal water supplies or support cold-water fisheries (Whitman, 1989; Neary et al., 1989; USEPA, 1984; Coats and Miller, 1981).

Twenty-four States have identified silviculture as a problem source contributing to NPS pollution in their 1990 section 305(b) assessments (USEPA, 1992b). Silviculture was the pollution source for 9 percent of NPS pollution to rivers in the 42 States reporting NPS pollution figures in section 305(b) assessments (USEPA, 1992b). States have reported up to 19 percent of their river miles to be impacted by silviculture. On Federal lands, such as national forests, many water quality problems can be attributed to the effects of timber harvesting and related activities (Whitman, 1989). In response to these impacts, many States have developed programs to address NPS pollution from forestry activities.

1. Pollutant Types and Impacts

Without adequate controls, forestry operations may degrade several water quality characteristics in waterbodies receiving drainage from forest lands. Sediment concentrations can increase due to accelerated erosion; water temperatures can increase due to removal of overstory riparian shade; slash and other organic debris can accumulate in waterbodies, depleting dissolved oxygen; and organic and inorganic chemical concentrations can increase due to harvesting and fertilizer and pesticide applications (Brown, 1985). These potential increases in water quality contaminants are usually proportional to the severity of site disturbance (Riekerk, 1983, 1985; Riekerk et al., 1989). Silvicultural NPS pollution impacts depend on site characteristics, climatic conditions, and the forest practices employed. Figure 3-1 presents a model of forest biogeochemistry, hydrology, and stormflow interactions.

Sediment. Sediment is often the primary pollutant associated with forestry activities (Pardo, 1980). Sediment is often defined as mineral or organic solid material that is eroded from the land surface by water, ice, wind, or other processes and is then transported or deposited away from its original location.

Sediment transported from forest lands into waterbodies can be particularly detrimental to benthic organisms and many fish species. When it settles, sediment fills interstitial spaces in lake bottoms or streambeds. This can eliminate essential habitat, covering food sources and spawning sites and smothering bottom-dwelling organisms and periphyton. Sediment deposition also reduces the capacity of stream channels to carry water and of reservoirs to hold water. This decreased flow and storage capacity can lead to increased flooding and decreased water supplies (Golden, et al., 1984).

Suspended sediments increase water turbidity, thereby limiting the depth to which light can penetrate and adversely affecting aquatic vegetation photosynthesis. Suspended sediments can also damage the gills of some fish species, causing them to suffocate, and can limit the ability of sight-feeding fish to find and obtain food.

Turbid waters tend to have higher temperatures and lower dissolved oxygen concentrations. A decrease in dissolved oxygen levels can kill aquatic vegetation, fish, and benthic invertebrates. Increases (or decreases) in water temperature outside the tolerance limits of aquatic organisms, especially cold-water fish such as trout and salmon, can also be lethal (Brown, 1974).

Nutrients. Nutrients from forest fertilizers, such as nitrogen and phosphorus adsorbed to sediments, in solution, or transported by aerial deposition, can cause harmful effects in receiving waters. Sudden removal of large quantities of vegetation through harvesting can also increase leaching of nutrients from the soil system into surface waters and ground waters by disrupting the nitrogen cycle (Likens et al., 1970). Excessive amounts of nutrients may cause enrichment of waterbodies, stimulating algal blooms. Large blooms limit light penetration into the water column, increase turbidity, and increase biological oxygen demand, resulting in reduced dissolved oxygen levels. This process, termed eutrophication, drastically affects aquatic organisms by depleting the dissolved oxygen these organisms need to survive.

Forest Chemicals. Herbicides, insecticides, and fungicides (collectively termed pesticides) used to control forest pests and undesirable plant species, can be toxic to aquatic organisms. Pesticides that are applied to foliage or soils, or are applied by aerial means, are most readily transported to surface waters and ground waters (Norris and Moore, 1971). Some pesticides with high solubilities can be extremely harmful, causing either acute or chronic effects in aquatic organisms, including reduced growth or reproduction, cancer, and organ malfunction or failure (Brown, 1974). Persistent pesticides that tend to sorb onto particulates are also of environmental concern since these relatively nonpolar compounds have the tendency to bioaccumulate. Other "chemicals" that may be released during forestry operations include fuel, oil, and coolants used in equipment for harvesting and road-building operations.

Organic Debris Resulting from Forestry Activities. Organic debris includes residual logs, slash, litter, and soil organic matter generated by forestry activities. Organic debris can adversely affect water quality by causing increased biochemical oxygen demand, resulting in decreased dissolved oxygen levels in watercourses. Logging slash and debris deposited in streams can alter streamflows by forming debris dams or rerouting streams, and can also

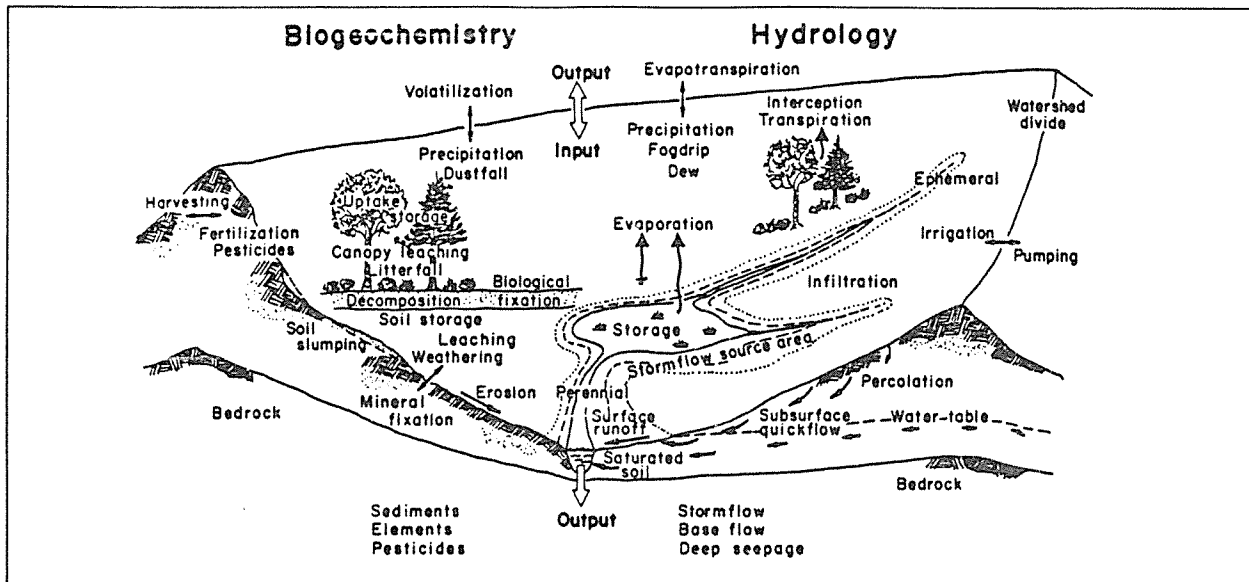

Figure 3-1. Conceptual model of forest biogeochemistry, hydrology and stormflow (Riekerk et al., 1989).

redirect flow in the channel, increasing bank cutting and resulting sedimentation (Dunford, 1962; Everest and Meehan, 1981). In some ecosystems, small amounts of naturally occurring organic material can be beneficial to fish production. Small streams in the Pacific Northwest may be largely dependent on the external energy source provided by organic materials such as leaves and small twigs. Naturally occurring large woody debris in streams can also create physical habitat diversity for rearing salmonids and can stabilize streambeds and banks (Everest and Meehan, 1981; Murphy et al., 1986).

Temperature. Increased temperatures in streams and waterbodies can result from vegetation removal in the riparian zone from either harvesting or herbicide use. These temperature increases can be dramatic in smaller (lower order) streams, adversely affecting aquatic species and habitat (Brown, 1972; Megahan, 1980; Curtis et al., 1990). Increased water temperatures can also decrease the dissolved oxygen holding capacity of a waterbody, increasing biological oxygen demand levels and accelerating chemical processes (Curtis et al., 1990).

Streamflow. Increased streamflow often results from vegetation removal (Likens et al., 1970; Eschner and Larmoyeux, 1963; Blackburn et al., 1982). Tree removal reduces evapotranspiration, which increases water availability to stream systems. The amount of streamflow increase is related to the total area harvested, topography, soil type, and harvesting practices (Curtis et al., 1990). Increased streamflows can scour channels, erode streambanks, increase sedimentation, and increase peak flows.

2. Forestry Activities Affecting Water Quality

The types of forestry activities affecting NPS pollution include road construction and use, timber harvesting, mechanical equipment operation, burning, and fertilizer and pesticide application (Neary et al., 1989).

Road Construction and Use. Roads are considered to be the major source of erosion from forested lands, contributing up to 90 percent of the total sediment production from forestry operations (Rothwell, 1983; Megahan, 1980; Patric, 1976). (See Figure 3-2.) Erosion potential from roads is accelerated by increasing slope gradients on cut-and-fill slopes, intercepting subsurface water flow, and concentrating overland flow on the road surface and in channels (Megahan, 1980). Roads with steep gradients, deep cut-and-fill sections, poor drainage, erodible soils, and road-stream crossings contribute to most of this sediment load, with road-stream crossings being the most frequent

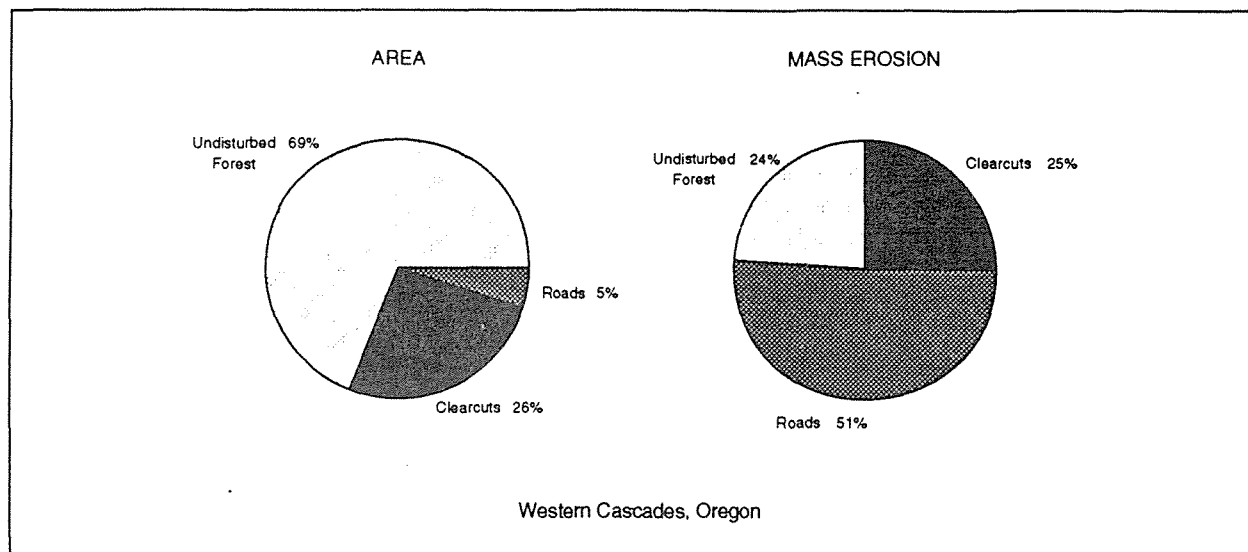

Figure 3-2. Comparison of forest land areas and mass erosion under various land uses (adapted from Sidle, 1989).

sources of erosion and sediment (Rothwell, 1983). Soil loss tends to be greatest during and immediately after road construction because of the unstabilized road prism and disturbance by passage of heavy trucks and equipment (Swift, 1984).

Brown and Krygier (1971) found that sediment production doubled after road construction on three small watersheds in the Oregon Coast Range. Dyrness (1967) observed the loss of 680 cubic yards of soil per acre from the H.J. Andrews Experimental Forest in Oregon due to soil erosion from roads on steep topography. Landslides were observed on all slopes and were most pronounced where forest roads crossed stream channels on steep drainage headwalls. Another example of severe erosion resulting from forestry practices occurred in the South Fork of the Salmon River in Idaho in the winter of 1965, following 15 years of intensive logging and road construction. Heavy rains triggered a series of landslides that deposited sediment on spawning beds in the river channel, destroying salmon spawning grounds (Megahan, 1981). Careful planning and proper road layout and design, however, can minimize erosion and prevent stream sedimentation (Larse, 1971).

Timber Harvesting. Most detrimental effects of harvesting are related to the access and movement of vehicles and machinery, and the skidding and loading of trees or logs. These effects include soil disturbance, soil compaction, and direct disturbance of stream channels. Logging operation planning, soil and cover type, and slope are the most important factors influencing harvesting impacts on water quality (Yoho, 1980). The construction and use of haul roads, skid trails, and landings for access to and movement of logs are the harvesting activities that have the greatest erosion potential.

Surveys of soil disturbance from logging were performed by Hornbeck and others (1986) in Maine, New Hampshire, and Connecticut. They found 18 percent of the mineral soil exposed by logging practices in Maine, 11 percent in New Hampshire, and 8 percent in Connecticut. Megahan (1986) reviewed several studies on forest land erosion and concluded that surface erosion rates on roads often equaled or exceeded erosion reported for severely eroding agricultural lands. Megahan (1986) found that in some cases erosion rates from harvest operations may approach erosion rates from roads and that prescribed burning can accelerate erosion beyond that from logging alone.

Another adverse impact of harvesting is the increase in stream water temperatures resulting from removal of streamside vegetation, with the greatest potential impacts occurring in small streams. However, streamside buffer strips have been shown to minimize the increase in stream temperatures (Brazier and Brown, 1973; Brown and Krygier, 1970).

Regeneration Methods. Regeneration methods can be divided into two general types: (1) regeneration from seedlings, either planted seedlings or existing seedlings released by harvesting, and (2) regeneration from seed, which can be seed from existing trees on or near the site or the broadcast application of seeds of the desired species. In some areas, regeneration with seedlings by mechanical tree planting is often conducted because it is faster and more consistent. Planting approaches relying on seeding generally require a certain amount of mineral soil to be exposed for seed establishment. For this reason, a site preparation technique is usually needed for regeneration by seeding.

Site Preparation. Mechanical site preparation by large tractors that shear, disk, drum-chop, or root-rake a site may result in considerable soil disturbance over large areas and has a high potential to deteriorate water quality (Beasley, 1979). Site preparation techniques that result in the removal of vegetation and litter cover, soil compaction, exposure or disturbance of the mineral soil, and increased stormflows due to decreased infiltration and percolation, all can contribute to increases in stream sediment loads (Golden et al., 1984). However, erosion rates decrease over time as vegetative cover grows back.

Prescribed burning and herbicides are other methods used to prepare sites that may also have potential negative effects on water quality. These activities are discussed below.

Prescribed Burning. Prescribed burning of slash can increase erosion by eliminating protective cover and altering soil properties (Megahan, 1980). The degree of erosion following a prescribed burn depends on soil erodibility, slope, precipitation timing, volume and intensity, fire severity, cover remaining on the soil, and speed of revegetation. Burning may also increase stormflow in areas where all vegetation is killed. Such increases are partially attributable to decreased evapotranspiration rates and reduced canopy interception of precipitation. Erosion resulting from prescribed burning is generally less than that resulting from roads and skid trails and from site preparation that causes intense soil disturbance (Golden et al., 1984). However, significant erosion can occur during prescribed burning if the slash being burned is collected or piled, causing soil to be moved and incorporated into the slash.

Application of Forest Chemicals. Adverse effects on water quality due to forest chemical application typically result from improper chemical application, such as failure to establish buffers around watercourses (Norris and Moore, 1971). Aerial application of forest chemicals has a greater potential to adversely affect water quality, especially if chemicals are applied under improper conditions, such as high winds (Riekerk et al., 1989), or are applied directly to watercourses.

F. Other Federal, State, and Local Silviculture Programs

1. Federal Programs

Forestry activities on Federal lands are predominantly controlled by the U.S. Department of Agriculture (USDA) Forest Service and Department of the Interior (DOI) Bureau of Land Management (BLM). Private entities operating on Federal lands are regulated by timber sales contracts. The Forest Service has developed preventive land management practices and project performance standards (USEPA, 1991). The Agricultural Stabilization and Conservation Service (ASCS) administers the Forestry Incentives Program (FIP) and Stewardship Incentives Program (SIP). Under FIP, ASCS provides cost-share funds to develop, manage, and protect eligible forest land, with emphasis on enhancing water quality, wildlife habitat, and recreational resources, and producing softwood timber. In addition, the Clean Water Act section 404 regulatory program may be applicable to some forestry activities (such as stream crossings) that involve the discharge of dredged or fill material into waters of the United States. However, section 404(f) of the Act exempts most forestry activities from permitting requirements. Regulations describing 404(f) exemptions, as well as applicable best management practices for section 404, have been published by EPA and the U.S. Army Corps of Engineers (40 CFR 232.3). The management measures in this guidance apply only to nonpoint source silvicultural activities. Clean Water Act section 402 regulations for point source permits exempt these nonpoint silvicultural activities (40 CFR 122.27) except for the section 404 requirements discussed above.

2. State Forestry NPS Programs

Most States with significant forestry activities have developed Best Management Practices (BMPs) to control silviculturally-related NPS water quality problems. Often, water quality problems are not due to ineffectiveness of the practices themselves, but to the failure to implement them appropriately (Whitman, 1989; Pardo, 1980).

There are currently two basic types of State forestry NPS programs, voluntary and regulatory. Thirty-five States currently implement voluntary programs, with 6 of these States having the authority to make the voluntary programs regulatory and 10 States backing the voluntary program with a regulatory program for non-compliers (see Table 3-1 for more specific types of programs). Nine States have developed regulatory programs (Essig, 1991).

Voluntary programs rely on a set of BMPs as guidelines to operators (Cubbage et al., 1989). Operator education and technology transfer are also a responsibility of State Forestry Departments. Workshops, brochures, and field tours are used to educate and to demonstrate to operators the latest water quality management techniques. Landowners are encouraged to hire operators who have a working knowledge of State forestry BMPs (Dissmeyer and Miller, 1991). Transfer of information on State NPS controls to landowners is also an important element of these programs.

Regulatory programs involve mandatory controls and enforcement strategies defined in Forest Practice Rules based on a State's Forest Practices Act or local government regulations. These programs usually require the implementation of BMPs based on site-specific conditions and water quality goals, and they have enforceable requirements (Ice, 1985). Often streams are classified based on their most sensitive designated use, such as importance for municipal water supply or propagation of aquatic life. Many water quality BMPs also improve harvesting operation efficiency and therefore can be applied in the normal course of forest harvest operations with few significant added costs (Ontario Ministry of Natural Resources, 1988; Dissmeyer and Miller, 1991). Harvest operation plans or applications to perform a timber harvest are frequently reviewed by the responsible State agency. Erosion and sedimentation control BMPs are also used in these programs to minimize erosion from road construction and harvesting activities.

Present State Coastal Zone Management (CZM) and section 319 programs may already include specific BMP regulations or guidelines for forestry activities. In some States, CZM programs have adopted State forestry regulations and BMPs through reference or as part of a linked program.

3. Local Governments

Counties, municipalities, and local soil and water conservation management districts may also impose additional requirements on landowners and operators conducting forestry activities. In urbanizing areas, these requirements often relate to concerns regarding the conversion of forested lands to urban uses or changes in private property values due to aesthetic changes resulting from forestry practices. In rural areas additional requirements for forestry activities may be implemented to protect public property (roads and municipal water supplies). Local forestry regulations tend to be stricter in response to residents' complaints (Salazar and Cubbage, 1990).

Table 3-1. State Programs by Region and Frequency (Henly and Ellefson, 1987)

Major Forestry Activity and Program Type	Frequency of States in Region Having Program Type									Total
	New England	Middle Atlantic	Lake States	Central States	South Atlantic	Southern States	Pacific States	N. Rocky Mountain	S. Rocky Mountain	
Water Quality Protection										
Tax Incentives	0	0	1	0	0	0	0	0	0	1
Financial Incentives	0	1	1	0	1	1	1	0	0	5
Educational Programs	5	2	3	5	3	8	3	3	3	35
Technical Assistance	6	5	3	6	3	6	2	4	5	40
Voluntary Guidelines	3	4	1	3	3	9	2	3	2	30
Legal Regulations	5	4	3	1	0	0	5	3	3	24
Reforestation and Timber Management										
Tax Incentives	1	2	3	5	1	2	0	2	0	16
Financial Incentives	1	3	3	4	3	4	2	1	1	22
Educational Programs	5	4	3	6	3	8	3	3	2	37
Technical Assistance	6	5	3	7	3	8	4	5	5	46
Voluntary Guidelines	0	2	2	2	3	3	1	1	2	16
Legal Regulations	1	3	1	1	0	0	4	1	3	14
Forest Protection										
Tax Incentives	0	1	0	0	0	0	0	0	0	1
Financial Programs	0	1	1	0	0	1	1	0	0	4
Educational Programs	5	5	3	6	3	9	1	3	3	38
Technical Assistance	6	5	3	7	3	9	4	4	5	46
Voluntary Guidelines	1	1	1	2	3	3	1	3	2	17
Legal Regulations	6	4	2	6	3	8	5	4	4	42
Wildlife and Aesthetic Management										
Tax Incentives	0	1	1	1	0	0	0	0	0	3
Financial Incentives	0	1	1	3	0	0	1	0	0	6
Educational Programs	4	3	3	5	3	7	1	4	2	32
Technical Assistance	5	5	3	6	3	7	4	4	4	41
Voluntary Guidelines	1	1	1	2	2	3	1	1	1	13
Legal Regulations	2	2	1	2	0	1	5	1	0	14

NOTE: Water Quality Protection focuses on nonpoint silvicultural sources of pollutants, vegetative buffer strips along waters, road and skid trail design and construction. Reforestation and Timber Management focuses on seed trees and other reforestation forms, timber harvesting system, clearcut size and design. Forest Protection focuses on slash treatment, other wildfire-related treatments, prescribed burn smoke management, herbicide and pesticide application, disease and insect management. Wildlife and Aesthetic Management focuses on wildlife habitat, scenic buffers along roadways, coastal zone management requirements.

Regional Groupings of States: New England-Connecticut, Maine, Massachusetts, New Hampshire, Rhode Island and Vermont; Middle Atlantic-Delaware, Maryland, New Jersey, New York, Pennsylvania and West Virginia; Lake States-Michigan, Minnesota, and Wisconsin; Central States-Illinois, Indiana, Iowa, Kansas, Kentucky, Missouri, Nebraska and Ohio; South Atlantic-North Carolina, South Carolina and Virginia; Southern States-Florida, Georgia, Alabama, Mississippi, Tennessee, Arkansas, Louisiana, Oklahoma and Texas; Pacific States-Alaska, California, Hawaii, Oregon and Washington; N. Rocky Mountain-Idaho, Montana, North Dakota, South Dakota and Wyoming; S. Rocky Mountain-Arizona, Colorado, Nevada, New Mexico and Utah.

II. FORESTRY MANAGEMENT MEASURES

A. Preharvest Planning

Perform advance planning for forest harvesting that includes the following elements where appropriate:

- (1) Identify the area to be harvested including location of waterbodies and sensitive areas such as wetlands, threatened or endangered aquatic species habitat areas, or high-erosion-hazard areas (landslide-prone areas) within the harvest unit.
- (2) Time the activity for the season or moisture conditions when the least impact occurs.
- (3) Consider potential water quality impacts and erosion and sedimentation control in the selection of silvicultural and regeneration systems, especially for harvesting and site preparation.
- (4) Reduce the risk of occurrence of landslides and severe erosion by identifying high-erosion-hazard areas and avoiding harvesting in such areas to the extent practicable.
- (5) Consider additional contributions from harvesting or roads to any known existing water quality impairments or problems in watersheds of concern.

Perform advance planning for forest road systems that includes the following elements where appropriate:

- (1) Locate and design road systems to minimize, to the extent practicable, potential sediment generation and delivery to surface waters. Key components are:
 - locate roads, landings, and skid trails to avoid to the extent practicable steep grades and steep hillslope areas, and to decrease the number of stream crossings;
 - avoid to the extent practicable locating new roads and landings in Streamside Management Areas (SMAs); and
 - determine road usage and select the appropriate road standard.
- (2) Locate and design temporary and permanent stream crossings to prevent failure and control impacts from the road system. Key components are:
 - size and site crossing structures to prevent failure;
 - for fish-bearing streams, design crossings to facilitate fish passage.
- (3) Ensure that the design of road prism and the road surface drainage are appropriate to the terrain and that road surface design is consistent with the road drainage structures.
- (4) Use suitable materials to surface roads planned for all-weather use to support truck traffic.
- (5) Design road systems to avoid high erosion or landslide hazard areas. Identify these areas and consult a qualified specialist for design of any roads that must be constructed through these areas.

Each State should develop a process (or utilize an existing process) that ensures that the management measures in this chapter are implemented. Such a process should include appropriate notification, compliance audits, or other mechanisms for forestry activities with the potential for significant adverse nonpoint source effects based on the type and size of operation and the presence of stream crossings or SMAs.

1. Applicability

This management measure pertains to lands where silvicultural or forestry operations are planned or conducted. The planning process components of this management measure are intended to apply to commercial harvesting on areas greater than 5 acres and any associated road system construction or reconstruction conducted as part of normal silvicultural activities. The component for ensuring implementation of this management measure applies to harvesting and road construction activities that are determined by the State agency to be of a sufficient size to potentially impact the receiving water or that involve SMAs or stream crossings. On Federal lands, where notification of forestry activities is provided to the Federal land management agency, the provisions of the final paragraph of this measure may be implemented through a formal agreement between the State agency and the Federal land management agency. This measure does not apply to harvesting conducted for precommercial thinning or noncommercial firewood cutting.

Under the Coastal Zone Act Reauthorization Amendments of 1990, States are subject to a number of requirements as they develop coastal nonpoint source programs in conformity with this measure and will have some flexibility in doing so. The application of this management measure by States is described more fully in *Coastal Nonpoint Pollution Control Program: Program Development and Approval Guidance*, published jointly by the U.S. Environmental Protection Agency (EPA) and the National Oceanic and Atmospheric Administration (NOAA) of the U.S. Department of Commerce.

2. Description

The objective of this management measure is to ensure that silvicultural activities, including timber harvesting, site preparation, and associated road construction, are conducted without significant nonpoint source pollutant delivery to streams and coastal areas. Road system planning is an essential part of this management measure since roads have consistently been shown to be the largest cause of sedimentation resulting from forestry activities. Good road location and design can greatly reduce the sources and transport of sediment. Road systems should generally be designed to minimize the number of road miles/acres, the size and number of landings, the number of skid trail miles, and the number of watercourse crossings, especially in sensitive watersheds. Timing operations to take advantage of favorable seasons or conditions, avoiding wet seasons prone to severe erosion or spawning periods for fish, is effective in reducing impacts to water quality and aquatic organisms (Hynson et al., 1982). For example, timber harvesting might be timed to avoid periods of runoff, saturated soil conditions, and fish migration and spawning periods.

Preharvest planning should include provisions to identify unsuitable areas, which may have merchantable trees but pose unacceptable risks for landslides or high erosion hazard. These concerns are greatest for steep slopes in areas with high rainfall or snowpack or sensitive rock types. Decomposed granite, highly weathered sedimentary rocks, and fault zones in metamorphic rocks are potential rock types of concern for landslides. Deep soils derived from these rocks, colluvial hollows, and fine-textured clay soils are soil conditions that may also cause potential problems. Such areas usually have a history of landslides, either occurring naturally or related to earlier land-disturbing activities.

Potential water quality and habitat impacts should also be considered when planning silvicultural harvest systems as even-aged (e.g., clearcut, seedtree, shelterwood) or uneven-aged (e.g., group selection or individual tree selection) and planning the type of yarding system. While it may appear to be more beneficial to water quality to use uneven-aged silvicultural stand management because less ground disturbance and loss of canopy cover occur, these factors should also be weighed against the possible effects of harvesting more acres selectively to yield equivalent timber volumes. Such harvesting may require more miles of road construction, which can increase sediment generation and increase levels of road management.

In addition, for uneven-aged systems, yarding in moderately sloping areas is usually done with groundskidding equipment, which can cause much more soil disturbance than cable yarding. For even-aged systems, cable yarding may be used in sloping areas; cable yarding is not widely used for uneven-aged harvesting. Whichever silvicultural

system is selected, planning will be required to minimize erosion and sediment delivery to waterbodies. Preharvest planning should address how harvested areas will be replanted or regenerated to prevent erosion and potential impact to waterbodies.

Cumulative effects to water quality from forest practices are related to several processes within a watershed (onsite mass erosion, onsite surface erosion, pollutant transport and routing, and receiving water effects) (Sidle, 1989). Cumulative effects are influenced by forest management activities, natural ecosystem processes, and the distribution of other land uses. Forestry operations such as timber harvesting, road construction, and chemical use may directly affect onsite delivery of nonpoint source pollutants as well as contribute to existing cumulative impairments of water quality.

In areas where existing cumulative effects problems *have already been assessed* for a watershed of concern, the potential for additional contributions to known water quality impairments or problems should be taken into account during preharvest planning. This does not imply that a separate cumulative effects assessment will be needed for each planned forestry activity. Instead, it points to the need to consider the potential for additional contributions to known water quality impairments based on information from previously conducted watershed or cumulative effects assessments. These types of water quality assessments, generally conducted by State or Federal agencies, may indicate water quality impairments in watersheds of concern caused by types of pollutants unrelated to forestry activities. In this case, there would be no potential for additional contributions of those pollutants from the planned forestry activity. However, if existing assessments attribute a water quality problem to the types of pollutants potentially generated by the planned forestry activity, then it is appropriate to consider this during the planning process. If additional contributions to this impairment are likely to occur as a result of the planned activity, this may necessitate adjustments in planned activities or implementation of additional measures. This may include selection of harvest units with low sedimentation risk, such as flat ridges or broad valleys; postponement of harvesting until existing erosion sources are stabilized; and selection of limited harvest areas using existing roads. The need for additional measures, as well as the appropriate type and extent, is best considered and addressed during the preharvest planning process.

Some important sediment sources related to roads are stream crossings, road fills on steep slopes, poorly designed road drainage structures, and road locations in close proximity to streams. Roads through high-erosion-hazard areas can also lead to serious water quality degradation. Some geographical areas have a high potential for serious erosion problems (landslides, major gullies, etc.) after road construction. Factors such as slope steepness, soil and rock characteristics, and local hydrology influence this potential. High-erosion-hazard areas may include badlands, loess deposits, steep and dissected terrain, and areas with existing landslides and are generally recognizable on the ground by trained personnel. Indications of hazard locations may include landslides, gullies, weak soils, unusually high ground water levels, very steep slopes, unvegetated shorelines and streambanks, and major geomorphic changes. Road system planning should identify and avoid these areas.

In most States, high-erosion-hazard areas are limited in extent. In the Pacific Coast States, however, road-related landslides are often the major source of sediment associated with forest management. Erosion hazard areas are often mapped, and these maps are one tool to use in identifying high-erosion-hazard sites. The U.S. Geological Survey has produced geologic hazard maps for some areas. The USDA Soil Conservation Service (SCS) and Agricultural Stabilization and Conservation Service (ASCS), as well as State and local agencies, may also have erosion-hazard-area maps.

Preplanning the timber harvest operation to ensure water quality protection will minimize NPS pollution generation and increase operation efficiency (Maine Forest Service, 1991; Connecticut RC&D Forestry Committee, 1990; Golden et al., 1984). The planning of streamside management area width and extent is also crucial because of SMAs' potential to reduce pollutant delivery. Identification and avoidance of high-hazard areas can greatly reduce the risk of landslides and mass erosion (Golden et al., 1984). Careful planning of road and skid trail system locations will reduce the amount of land disturbance by minimizing the area in roads and trails, thereby reducing erosion and sedimentation (Rothwell, 1978). Studies at Fernow Experimental Forest, West Virginia, demonstrated that good planning reduced skid road area by as much as 40 percent (Kochenderfer, 1970).

Designing road systems prior to construction to minimize road widths, slopes, and slope lengths will also significantly reduce erosion and sedimentation (Larse, 1971). The most effective road system results from planning conducted to serve an entire basin, rather than arbitrarily constructing individual road projects to serve short-term needs (Swift, 1985). The key environmental factors involved in road design and location are soil texture, slope, aspect, climate, vegetation, and geology (Gardner, 1967).

Proper design of drainage systems and stream crossings can prevent system destruction by storms, thereby preventing severe erosion, sedimentation, and channel scouring (Swift, 1984). Removal of excess water from roads will also reduce the potential for grade weakening, surface erosion, and landslides. Drainage problems can be minimized when locating roads by avoiding clay beds, seeps, springs, concave slopes, muskegs, ravines, draws, and stream bottoms (Rothwell, 1978).

Developing a process, or utilizing an existing process, to ensure that the management measures in this chapter are implemented is an important component for forestry nonpoint source control programs. While silvicultural management of forests may extend over long stand rotation periods of 20 to 120 years and cover extensive areas of forestland, the forestry operations that generate nonpoint source pollution, like harvesting and road building, are of relatively short duration and occur in dispersed, often isolated locations in forested areas. Forest harvesting or road building operations are usually operational on a given site only for a period of weeks or months. These operational phases are then followed by the much longer period of regrowth of the stand or the rotation period. Since forestry operations are relatively dispersed and move from site to site within forested areas, it is essential to have some process to ensure implementation of management measures. For example, it is not possible to track the implementation of management measures or determine their effectiveness if there is no way of knowing where or when they might be applied. In the case of monitoring or water quality assessments, correlation of water quality conditions to forestry activities is not possible absent some ability to determine where and to what extent forestry operations are being conducted and whether management measures are being implemented. Because of the dispersed and episodic nature of forestry operations, many States have implemented programs that currently incorporate a process such as notification to ensure implementation and to facilitate evaluation of program implementation and assessment of water quality conditions.

This process has been shown to be a beneficial device for ensuring the implementation of water quality best management practices, particularly for forestry activities. In contrast to the typical forestry situation, nonpoint pollution from urban and agricultural sources is generated from areas and activities that are relatively stationary and repetitive. Because of this, these sources of nonpoint pollution are more apparent and readily addressed than more isolated and episodic forestry operations. Given the unique nature of forestry operations, it is necessary for States to have some mechanism for being apprised of forestry activities in order to uniformly address sources of nonpoint pollution.

This Forestry Management Measure component allows considerable flexibility to States for determining how this provision should be carried out in the coastal zone. For the purposes of this management measure, such a process should include appropriate notification mechanisms for forestry activities with the potential for nonpoint source impacts. It is important to point out that for the purposes of this management measure such a notification process might be either verbal or written and does *not* necessarily require submittal and approval of written preharvest plans (although those States that currently require submittal of a preharvest plan would also fulfill this management measure component for the coastal zone program). States also have flexibility in determining what information should be provided and how this should occur for notification mechanisms. Timing and location of the planned forestry operation are common elements of existing notification requirements and may serve as an acceptable minimum. Existing programs for forestry have found some type of notification of the planned activity to the appropriate State agency to be a very beneficial device for ensuring the implementation of water quality best management practices for silvicultural activities. At least 12 Coastal Zone Management Program States currently require some type of notification, associated with Forest Practices Acts, CWA section 404 requirements, tax incentive or cost share programs, State Forester technical assistance, severance tax filings, stream crossing permits, labor permits, erosion control permits, or land management agency agreements.

3. Management Measure Selection

The rationale for this measure is based on information on the effects of various harvesting practices and the effectiveness and costs of planning, design, and location components addressed in this measure. This measure is also based in part on the experience of some States in using preharvest planning as part of implementation of best management practices.

a. Effectiveness Information

Preharvest planning has been demonstrated to play an important role in the control of nonpoint source pollution and efficient forest management operations. A fundamental component to be considered in timber harvest planning is the selection of the silvicultural system. Research conducted by Beasley and Granillo (1985) demonstrated that selective cutting generated lower water yields and sediment yields than did clearcutting. This is important not only because of the sediment loss, but also because higher stormflows can undercut streambanks and scour channels, reducing channel stability. The data in Table 3-2 show that selective cutting results in sediment yields 2.5 to 20 times less and water yields 1.3 to 2.6 times less than those resulting from clearcutting. As stated previously, the amount and potential water quality impacts of roads needed for each system must also be taken into account.

Methods used for harvesting are closely related to the silvicultural system. Four harvesting methods combined with varying types of management practices to protect water quality, including road location, were compared in a study conducted by Eschner and Larmoyeux (1963) (Table 3-3). Harvesting effects on water quality, as measured by turbidity, were shown to be clearly related to the care taken in logging and planning skid roads. The extensive

**Table 3-2. Clearcutting Versus Selected Harvesting Methods (AR)
(Beasley and Granillo, 1985)**

Water Year	Treatment	Mean Annual Water Yield (cm)	Mean Annual Sediment Losses (kg/ha)
1981 (Preharvest)	Clearcut	6.4	41
	Selection	7.4	52
	Control	6.8	52
1982	Clearcut	13.2	264
	Selection	5.1	13
	Control	1.0	4
1983	Clearcut	44.7	63
	Selection	33.8	26
	Control	31.0	19
1984	Clearcut	32.8	83
	Selection	14.5	15
	Control	17.5	46
1985	Clearcut	27.9	73
	Selection	12.3	12
	Control	15.9	17

selection method, combined with some NPS controls (20 percent road grade limits, no skidding in streams, water bars on skid roads), produced higher maximum levels of turbidity than did intensive selection with additional control practices (10 percent road grade limits; skid trails located away from streams). Harvesting by the diameter limit practice without any restrictions on road grades or stream restrictions increased maximum turbidity by 200 times over intensive selection, and commercial clearcutting with no controls increased maximum turbidity by over three orders of magnitude. This study concluded that care taken in preharvest planning of skid roads and logging operations can prevent most potential impairment to water quality.

McMinn (1984) compared a skidder logging system and a cable yarder for their relative effects on soil disturbance (Table 3-4). With the cable yarder, 99 percent of the soil remained undisturbed (the original litter still covered the mineral soil), while the amount of soil remaining undisturbed after logging by skidder was only 63 percent. Beasley, Miller, and Gough (1984) related sediment loss associated with forest roads to the average slope gradient of road segments (Table 3-5). The greater the average slope gradient, the greater the soil loss, ranging from a total of 6.8 tons/acre lost when the slope gradient was 1 percent, to 19.4 tons/acre at 4 percent, to 32.3 tons/acre at 6 percent, to 33.7 tons/acre at 7 percent.

Sidle (1980) found that the impacts of tractor skidding can be lessened through the use of preplanned skid roads and landings designed so that the area disturbed by road construction and the overall extent of sediment compaction at the site are minimized. Sidle (1980) described a study in North Carolina that showed that preplanning roads could result in a threefold decrease in soil compaction at the logging area.

**Table 3-3. Effect of Four Harvesting and Road Design Methods on Water Quality (WV, PA)
(Eschner and Larmoyeux, 1963)**

Watershed Number	Practice	Maximum Turbidity (Turbidity units)	Frequency Distribution of Samples Turbidity Unit Classes				Total
			0 to 10	11 to 99	100 to 999	1000+	
1	Commercial clearcut ^a	56,000	126	40	24	13	203
2	Diameter limit ^b	5,200	171	17	8	7	203
5	Extensive selection ^d	210 ^c	195	8	0	0	203
3	Intensive selection ^e	25	201	2	0	0	203
4	Control	15	202	1	0	0	203

Note: Includes regularly scheduled samples and special samples in storm periods.

^a Skid roads were not planned but were "logger's choice."

^b Trees over 17 inches DBH were cut. Water bars placed at 2-chain intervals along skid roads.

^c Not included in frequency distribution. This sample was taken at a time when the other watersheds were not sampled.

^d Trees over 11 inches DBH were cut. Maximum skid road grade was 20 percent, with water bars installed as needed. Skidding was prohibited in streams.

^e With intensive selection, trees over 5 inches DBH were cut. Maximum skid road grade was 10 percent. Skidding was prohibited in streams, and roads were located away from streams. Water bars were used as needed, and disturbed areas were stabilized with grass seeding.

Table 3-4. Comparison of the Effect of Conventional Logging System and Cable Miniyarder on Soil (GA) (McMinn, 1984)

Disturbance Class ^a	Cable Skidder (percent)	Miniyarder (percent)
Undisturbed	63	99
Soil exposed	12	1
Soil disturbed	25	0

^a Undisturbed = original duff or litter still covering the mineral soil.
Exposed = litter and duff scraped away, exposing mineral soil, but no scarification.
Disturbed = Mineral soil exposed and scarified or dislocated.

Table 3-5. Relationship Between Slope Gradient and Annual Sediment Loss on an Established Forest Road^a (AR) (Beasley, Miller, and Gough, 1984)

Average Slope Gradient of Road Segment (percent)	Soil Deposited ^b		Suspended Solids		Total	
	tons per acre	tons per mile	tons per acre	tons per mile	tons per acre	tons per mile
7	21.6	54.0	12.0	30.0	33.7	84.0
6	10.2	26.7	22.1	57.8	32.3	84.5
4	5.0	11.3	14.4	32.6	19.4	43.8
1	0.2	0.3	6.6	12.4	6.8	12.7

^a The length of the road segments averaged 330 feet, ranging from 308 to 357 feet. Most of the other physical characteristics of the road were consistent, except the variation in the proportion of backslope to total area. Fill slopes below the road segments were well vegetated. Cut slopes were steep, bare, and actively eroding.

^b Measured in upslope, inside ditches.

Several researchers have emphasized that prevention is the most effective approach to erosion control for road activities (Megahan, 1980; Golden et al., 1984). Because roads are the greatest source of surface erosion from forestry operations, reducing road surface area while maintaining efficient access is a primary component of proper road design. Careful planning of road layout and design can minimize erosion by as much as 50 percent (Yoho, 1980; Weitzman and Trimble, 1952). This practice has the added benefits of reducing construction, maintenance, and transport costs and increasing forested area for production. Rice et al. (1972) found no increase in sedimentation from a well-designed logging road on gently sloping, stable soils in Oregon except for during the construction period.

Locating roads on low gradients is another planning component that can reduce the impacts of sedimentation. Trimble and Weitzman (1953) presented data showing that lower gradients and shorter road lengths reduce erosion. The same authors, in a 1952 journal article, also presented data showing that reduced gradients in conjunction with water bars can significantly reduce erosion from roads. The data from these two studies are presented in Table 3-6.

b. Cost Information

A cost-benefit analysis by Dissmeyer and others (USDA, 1987) reveals the dramatic, immediate savings from considering water quality during the design phase of a road reconstruction project (Table 3-7). Expertise on soil and water protection provided by a hydrologist resulted in 50 percent of the savings alone. Other long-term economic benefits of careful planning such as longer road life and reduced maintenance costs were not quantified in this analysis.

Table 3-6. The Effect of Skid Road Grade and Length on Road Surface Erosion (WV, PA) (Trimble and Weitzman, 1953)

Skid Road Type (Grade and Length of Slope)	Erosion from Skid Road Surface After Logging		
	Erosion (in)	Average Grade (%)	Average Length (ft)
0-20% grade/0-132 feet	0.4	10	46
21-40% grade/0-132 feet	0.7	29	55
133-264 feet	1.0	35	211

Table 3-7. Costs and Benefits of Proper Road Design (With Water Quality Considerations) Versus Reconstruction (Without Water Quality Considerations) (USDA Forest Service, 1987)

	Without Soil/ Water Input ^a	With Soil/Water Input ^a
Miles of road	3.0	3.0
Reconstruction costs	\$796,000	\$372,044
Soil/water input costs	--	\$800
Immediate benefit (savings) of soil/water input	--	\$211,978

^a Soil/water inputs are design adjustments made by a hydrologist and include narrower road width and steeper road bank cuts in soils of low erodibility and low revegetation potential.

Kochenderfer, Wendel, and Smith (1984) determined the costs for locating four minimum standard roads in the Central Appalachians (Table 3-8). Road location costs increased as the terrain became more difficult (e.g., had a large number of rock outcrops or steep slopes) or required several location changes. Typically, road location costs accounted for approximately 8 percent of total costs.

Ellefson and Miles (1984) performed an economic evaluation of forest practices to curb nonpoint source water pollutants. They presented the cumulative decline in net revenue of 1.2 percent for the practices of skid trail and landing design for a sale with initial net revenue of \$124,340.

4. Practices

As discussed more fully at the beginning of this chapter and in Chapter 1, the following practices are described for illustrative purposes only. State programs need not require implementation of these practices. However, as a practical matter, EPA anticipates that the management measure set forth above generally will be implemented by applying one or more management practices appropriate to the source, location, and climate. The practices set forth below have been found by EPA to be representative of the types of practices that can be applied successfully to achieve the management measure discussed above.

a. Harvesting Practices

■ Consider potential water quality and habitat impacts when selecting the silvicultural system as even-aged (clearcut, seedtree, or shelterwood) or uneven-aged (group or individual selection). The yarding system, site preparation method, and any pesticides that will be used should also be addressed in

Table 3-8. Characteristics and Road Location^a Costs of Four "Minimum-Standard" Forest Truck Roads Constructed in the Central Appalachians (Kochenderfer, Wendel, and Smith, 1984)

Road Number	Road Length (miles)	Road Grade (%)	Number of Dips ^b	Culvert			Location Costs (\$/miles)
				Number	Size (in)	Length (ft)	
1	0.81	6.9	22	1	18	39	585
6	0.78	2.7	15	5	15	135	615
7	0.34	3.7	5	2	15	64	720
8	1.25	2.6	30	0			585

^a Road location includes the cost to plan, reconnoiter, and lay out 1 mile of road.

^b Includes natural grade breaks where dozer work is required for outcropping.

preharvest planning. As part of this practice the potential impacts from and extent of roads needed for each silvicultural system should be considered.

- *In warmer regions, schedule harvest and construction operations during dry periods/seasons. In temperate regions, harvest and construction operations may be scheduled during the winter to take advantage of snow cover and frozen ground conditions.*
- *To minimize soil disturbance and road damage, limit operations to periods when soils are not highly saturated (Rothwell, 1978). Damage to forested slopes can also be minimized by not operating logging equipment when soils are saturated, during wet weather, or in periods of ground thawing.*
- *Planned harvest activities or chemical use should not contribute to problems of cumulative effects in watersheds of concern.*
- *Use topographic maps, aerial photography, soil surveys, geologic maps, and rainfall intensity charts to augment site reconnaissance to lay out and map harvest unit; identify and mark, as needed:*
 - *Any sensitive habitat areas needing special protection such as threatened and endangered species nesting areas,*
 - *Streamside management areas,*
 - *Steep slopes, high-erosion-hazard areas, or landslide prone areas,*
 - *Wetlands.*
- *In high-erosion-hazard areas, trained specialists (geologist, soil scientist, geotechnical engineer, wildland hydrologist) should identify sites that have high risk of landslides or that may become unstable after harvest and should recommend specific practices to control harvesting and protect water quality.*
- *Lay out harvest units to minimize the number of stream crossings.*
- *States are encouraged to adopt notification mechanisms that integrate and avoid duplicating existing requirements for notification including severance taxes, stream crossing permits, erosion control permits, labor permits, forest practice acts plans, etc. For example, States may require one preharvest*

plan that the landowner could submit to just one State or local office. The appropriate State agency might encourage forest landowners to develop a preharvest plan. The plan would address the components of this management measure including the area to be harvested, any forest roads to be constructed, and the timing of the activity.

b. Road System Practices

■ *Preplan skid trail and landing location on stable soils and avoid steep gradients, landslide-prone areas, high-erosion-hazard areas, and poor-drainage areas.*

- Landings should not be located in SMAs.
- New roads and skid trails should not be located in SMAs, except at crossings. Existing roads and landings in the SMA will be closed unless the construction of new roads and landings to access an area will cause greater water quality impacts than the use of existing roads.
- Roads should not be located along stream channels where road fill extends within 50-100 horizontal feet of the *annual* high water level. (Bankfull stage is also used as reference point for this.)

■ *Systematically design transportation systems to minimize total mileage.*

- Weigh skid trail length and number against haul road length and number.
- Locate landings to minimize skid trail and haul road mileage (Rothwell, 1978).

■ *Utilize natural log landing areas to reduce the potential for soil disturbance (Larse, 1971; Yee and Roelofs, 1980).*

■ *Plot feasible routes and locations on an aerial photograph or topographic map to assist in the final determination of road locations.*

Proper design will reduce the area of soil exposed by construction activities. Figure 3-3 presents a comparison of road systems.

■ *In moderately sloping terrain, plan for road grades of less than 10 percent, with an optimal grade between 3 percent and 5 percent. In steep terrain, short sections of road at steeper grades may be used if the grade is broken at regular intervals. Vary road grades frequently to reduce culvert and road drainage ditch flows, road surface erosion, and concentrated culvert discharges (Larse, 1971).*

Gentle grades are desirable for proper drainage and economical construction (Ontario Ministry of Natural Resources, 1988). Steeper grades are acceptable for short distances (200-300 feet), but an increased number of drainage structures may be needed above, on, and below the steeper grade to reduce runoff potential and minimize erosion. In sloping terrain, no-grade road sections are difficult to drain properly and should be avoided when possible.

■ *Design skid trail grades to be 15 percent or less, with steeper grades only for short distances.*

■ *Design roads and skid trails to follow the natural topography and contour, minimizing alteration of natural features.*

This practice will reduce the amount of cut and fill required and will consequently reduce road failure potential. Ridge routes and hillside routes are good locations for ensuring stream protection because they are removed from stream channels and the intervening undisturbed vegetation acts as a sediment barrier. Wide valley bottoms are good routes if stream crossings are few and roads are located outside of SMAs (Rothwell, 1978).

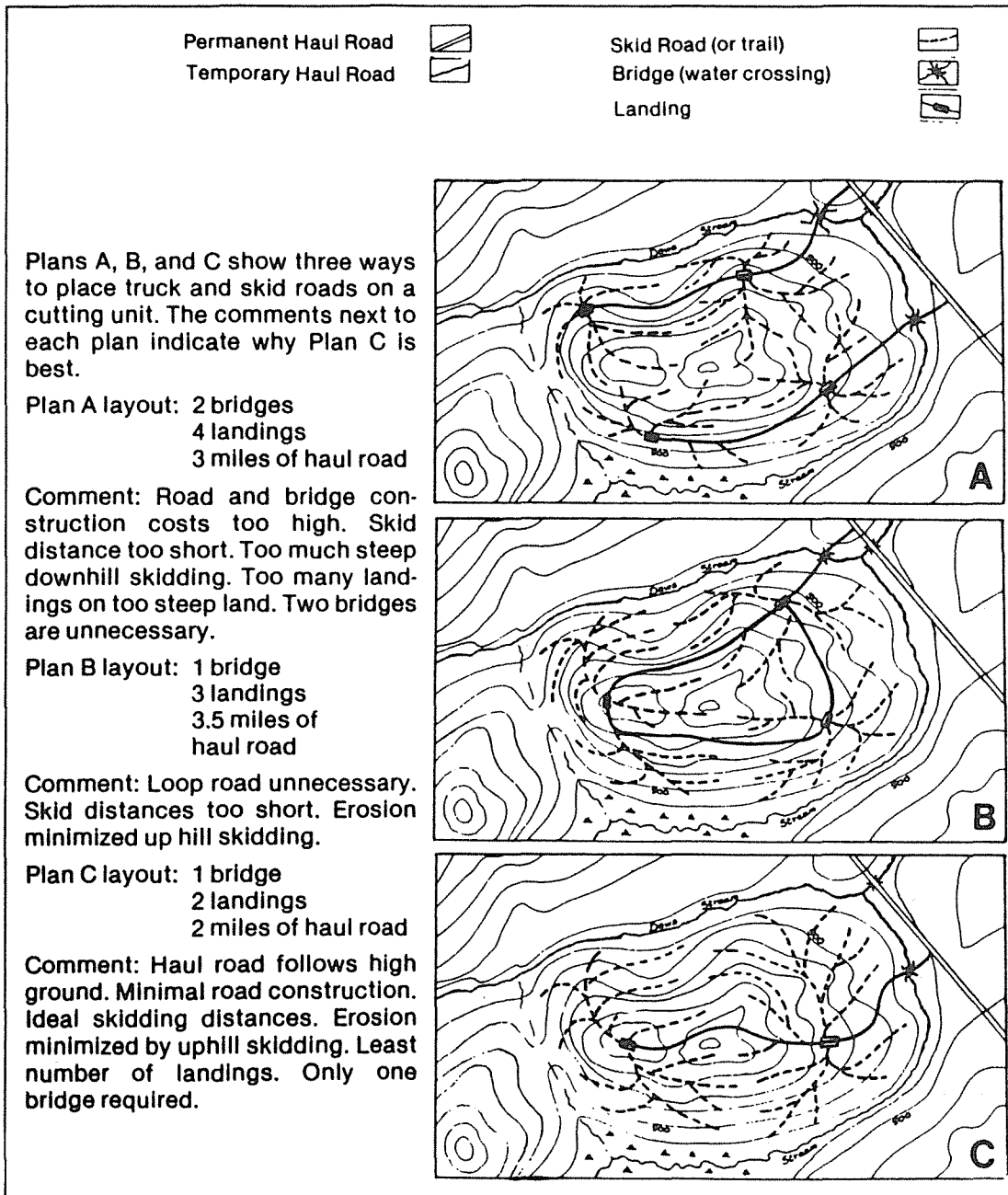

Figure 3-3. How to select the best road layout (Hynson et al., 1982).

■ Roads in steep terrain should avoid the use of switchbacks through the use of more favorable locations. Avoid stacking roads above one another in steep terrain by using longer span cable harvest techniques.

■ Design roads crossing low-lying areas so that water does not pond on the upslope side of the road.

- Use overlay construction techniques with suitable nonhazardous materials for roads crossing muskegs.
- Provide cross drains to allow free drainage and avoid ponding, especially in sloping areas.

- Do not locate and construct roads with fills on slopes greater than 60 percent. When necessary to construct roads across slopes that exceed the angle of repose, use full-bench construction and/or engineered bin walls or other stabilizing techniques.
- Use full-bench construction and removal of fill material to a suitable location when constructing road prisms on sideslopes greater than 60 percent.
- Design cut-and-fill slopes to be at stable angles, or less than the normal angle of repose, to minimize erosion and slope failure potential.

The degree of steepness that can be obtained is determined by the stability of the soil (Rothwell, 1978). Figure 3-4 depicts proper cut-and-fill construction. Table 3-9 presents an example of stable backslope and fill slope angles for different soil materials.

- Use retaining walls, with properly designed drainage, to reduce and contain excavation and embankment quantities (Larse, 1971). Vertical banks may be used without retaining walls if the soil is stable and water control structures are adequate.
- Balance excavation and embankments to minimize the need for supplemental building material and to maximize road stability.
- Do not use road fills at drainage crossings as water impoundments unless they have been designed as an earthfill dam that may be subject to section 404 requirements. These earthfill embankments should have outlet controls to allow draining prior to runoff periods and should be designed to pass flood flows.

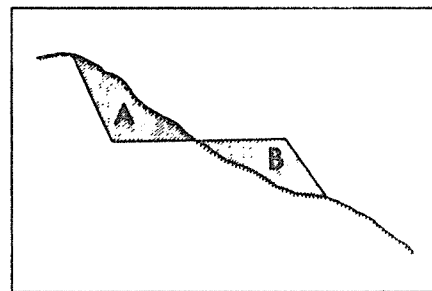

Figure 3-4. Typical side-hill cross section illustrating how cut material, A, equals fill material, B (Rothwell, 1978).

- Allow time after construction for disturbed soil and fill material to stabilize prior to use (Huff and Deal, 1982). Roads should be compacted and stabilized prior to use. This will reduce the amount of maintenance needed during and after harvesting activities (Kochenderfer, 1970).

Table 3-9. Stable Back Slope and Fill Slope Angles for Different Soil Materials (Rothwell, 1978)

Back Slopes		Fill Slopes	
Flat ground cuts under 0.9 m	2:1	Common for most soil types	1½:1
Most soil types with ground slopes <55%	1:1	Alluvial soils	2:1
Most soil types with ground slopes >55%	¾:1	Ballast	1:1
Hardpan of soft rock	½:1	Clay	4-1:1
Solid rock	¼:1	Rock, crushed	1-¼:1
		Gravel	1:1
		Sand, moist	1½-1:1
		Sand, saturated	2:1
		Shale	1½:1

■ *Use existing roads, whenever practical, to minimize the total amount of construction necessary.*

Do not plan and construct a road when access to an existing road is available on the opposite side of the drainage. This practice will minimize the amount of new road construction disturbance. However, avoid using existing or past road locations if they do not meet needed road standards (Swift, 1985).

■ *Minimize the number of stream crossings for roads and skid trails. Stream crossings should be designed and sited to cross drainages at 90° to the streamflow.*

■ *Locate stream crossings to minimize channel changes and the amount of excavation or fill needed at the crossing (Furniss et al., 1991). Apply the following criteria to determine the locations of stream crossings (Hynson et al., 1982):*

- Use a streambed with a straight and uniform profile above, at, and below the crossing;
- Locate crossing so the stream and road alignment are straight in all four directions;
- Cross where the stream is relatively narrow with low banks and firm, rocky soil; and
- Avoid deeply cut streambanks and soft, muddy soil.

■ *Choose stream-crossing structures (bridges, culverts, or fords) with the structural capacity to safely handle expected vehicle loads with the least disturbance to the watercourse. Consider stream size, storm frequency and flow rates, intensity of use (permanent or temporary), water quality, and habitat value, and provide for fish passage.*

■ *Select the waterway opening size to minimize the risk of washout during the expected life of the structure.*

Bridges or arch culverts, which retain the natural stream bottom and slope, are preferred over pipe culverts for streams that are used for fish migrating or spawning areas (Figures 3-5 and 3-6). Fish passage may be provided in streams that have wide ranges of flow by providing multiple culverts (Figure 3-7).

■ *Design culverts and bridges for minimal impact on water quality. Size small culverts to pass the 25-year flood, and size major culverts to pass the 50-year flood. Design major bridges to pass the 100-year flood.*

■ *The use of fords should be limited to areas where the streambed has a firm rock or gravel bottom (or where the bottom has been armored with stable material), where the approaches are both low and stable enough to support traffic, where fish are not present during low flow, and where the water depth is no more than 3 feet (Ontario Ministry of Natural Resources, 1988; Hynson et al., 1982).*

■ *For small stream crossings on temporary roads, the use of temporary bridges is recommended.*

Temporary bridges usually consist of logs bound together and suspended above the stream, with no part in contact with the stream itself. This prevents streambank erosion, disturbance of stream bottoms, and excessive turbidity (Hynson et al., 1982). Provide additional capacity to accommodate debris loading that may lodge in the structure opening and reduce its capacity.

■ *When temporary stream crossings are used, remove culverts and log crossings upon completion of operations.*

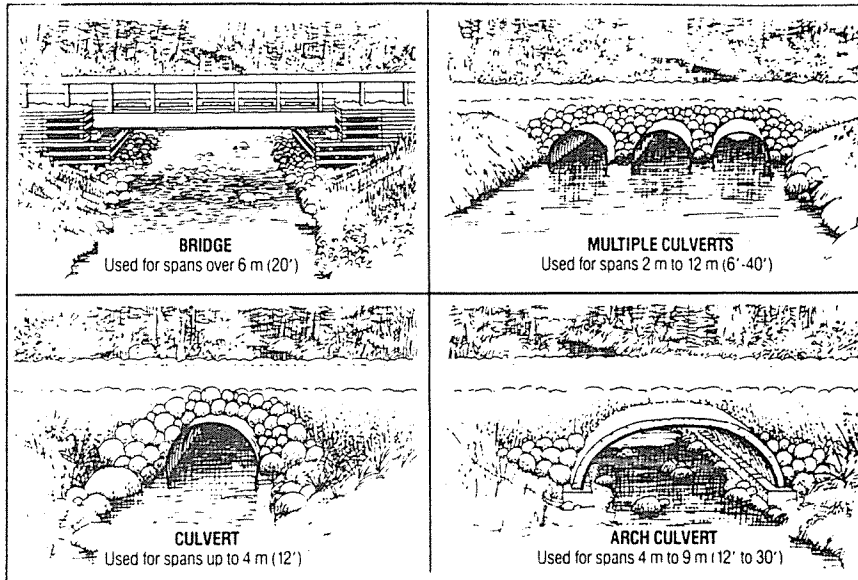

Figure 3-5. Alternative water crossing structures (Ontario Ministry of Natural Resources, 1988).

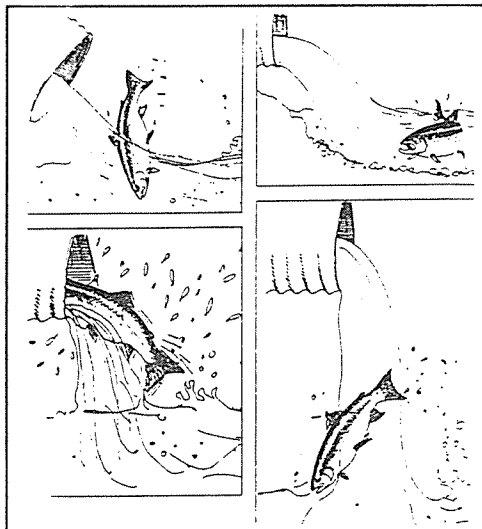

Figure 3-6. Culvert conditions that block fish passage (Yee and Roelofs, 1980).

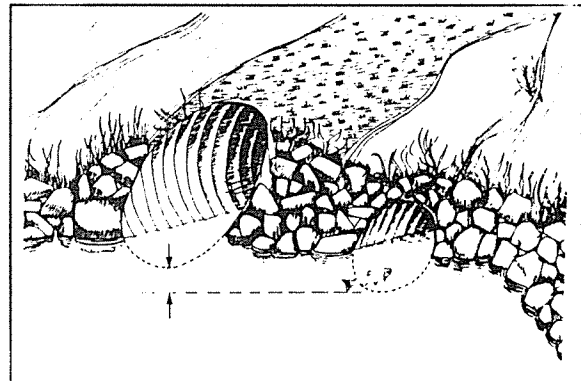

Figure 3-7. Multiple culverts for fish passage in streams that have wide ranges of flows (Hynson et al., 1982).

- Springs flowing continuously for more than 1 month should have drainage structures rather than allowing road ditches to carry the flow to a drainage culvert.
- Most forest roads should be surfaced, and the type of road surface will usually be determined by the volume and composition of traffic, the maintenance objectives, the desired service life, and the stability and strength of the road foundation (subgrade) material (Larse, 1971).

Figure 3-8 compares roadbed erosion rates for different surfacing materials.

- Surface roads (with gravel, grass, wood chips, or crushed rocks) where grades increase the potential for surface erosion.
- Use appropriately sized aggregate, appropriate percent fines, and suitable particle hardness to protect road surfaces from rutting and erosion under heavy truck traffic during wet periods. Ditch runoff should not be visibly turbid during these conditions. Do not use aggregate containing hazardous materials or high sulfide ores.
- Plan water source developments, used for wetting and compacting roadbeds and surfaces, to prevent channel bank and streambed impacts. Access roads should not provide sediment to the water source.
- Many States currently utilize some process to ensure implementation of management practices. These processes are typically related to the planning phase of forestry operations and commonly involve some type of notification process. Some States have one or more processes in place which serve as notification mechanisms used to ensure implementation. These State processes are usually associated with either Forest Practices Acts, Erosion Control Acts, State Dredge and Fill or CWA Section 404 requirements, timber tax requirements, or State and Federal incentive and cost share programs. The examples of existing State processes below illustrate some of these which might also be used as mechanisms to ensure implementation of management measures.

Florida Water Management Districts require notification prior to conducting forestry operations that involve stream crossings. This is required in order to meet the requirements of a State Dredge and Fill general permit, comparable to a CWA section 404 requirement. This notification is usually done by mail, but at least one water management district also allows verbal notification for some types of operations by telephoning an answering machine. In Florida, notification is required for any crossing of "Waters of the State," including wetlands, intermittent streams and creeks, lakes, and ponds. If any of these waters in the State are to be crossed during forestry operations, either by haul roads or by groundskidding, then notification is needed and State BMPs are required by reference in the general permit. Notification is usually provided by mailing in a notification sheet, which says who will conduct the operation and where it will be conducted (see Appendix 3A, Example 3A-1). In addition, information on what type of operation will be conducted, the name of a contact person, and a sketch of the site are included. Use of pesticides for forestry applications in Florida also requires licensing by the State Bureau of Pesticides.

The Oregon Forest Practice Rules require that the landowner or operator notify the State Forester at least 15 days prior to commencement of the following activities: (1) harvesting of forest tree species; (2) construction, reconstruction and improvement of roads; (3) application of pesticides and fertilizers; (4) site preparation for reforestation involving clearing or use of heavy machinery; (5) clearing forest land for conversion to any non-forest use; (6) disposal or treatment of slash; (7) pre-commercial thinning; and (8) cutting of firewood, when the firewood will be sold or used for

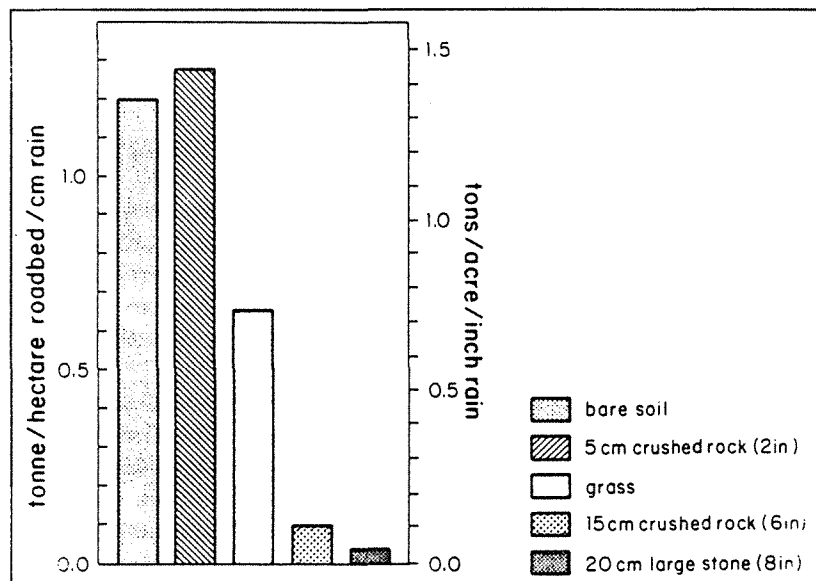

Figure 3-8. Soil loss rates for roadbeds with five surfacing treatments. Roads constructed of sandy loam saprolite (Swift, 1988).

barter. The State must approve the activity within 15 days and may require the submittal of a written plan. In addition, the preparation and submittal of a written plan is required for all operation within 100 feet of Class I waters, which are waters that support game fish or domestic uses, or within 300 feet of wetlands and sensitive wildlife habitat areas. Appendix 3A, Example 3A-2 contains a copy of Oregon's Notification of Operation/Application for Permit form. Oregon has developed a system of prioritization for the review and approval of these written plans. In Oregon, notification of intent to harvest is provided to the Department of Revenue through the Department of Forestry for purposes of tax collection. Additional permits for operation of power-driven machinery and to clear rights-of-way for road systems are also required.

New Hampshire does not have a Forest Practices Act, but does have a number of other State processes that serve as notification mechanisms for forestry activities. Prior to conducting forest harvesting, an Intent to Cut Application must be submitted to the Department of Revenue Administration (see Appendix 3A, Example 3A-3). This is required for the timber yield tax, and is filed in order to get a certificate for intent to cut. The Intent to Cut Application must be accompanied by an application for Filling, Dredging or Construction of Structures for those operations that involve the crossing of any freshwater wetland, intermittent or perennial stream, or other surface water. If the activity is not considered a minimum impact, a written plan must be submitted and approved before work may begin. Signature of these applications by the owner or operator adopts by reference the provisions of the State Best Management Practice Handbook. The State Erosion Control Act also requires notification for obtaining a permit for ground-disturbing activities greater than 100,000 square feet. This permit is required prior to commencement of operations. Another State process that entails notification is the provisions for the prevention of pollution from terrain alteration. These provisions require the submission of a plan 30 days before conducting the transport of forest products in or on the border of the surface waters of the State or before significantly altering the characteristics of the terrain in such a manner as to impede the natural runoff or create an unnatural runoff. The State must grant written permission before operations of this type may take place. Each of these existing State mechanisms entails the notification of the State prior to conducting forestry operations. Pesticides licensing is also necessary if the forestry operation involves the application of herbicides or insecticides.

B. Streamside Management Areas (SMAs)

Establish and maintain a streamside management area along surface waters, which is sufficiently wide and which includes a sufficient number of canopy species to buffer against detrimental changes in the temperature regime of the waterbody, to provide bank stability, and to withstand wind damage. Manage the SMA in such a way as to protect against soil disturbance in the SMA and delivery to the stream of sediments and nutrients generated by forestry activities, including harvesting. Manage the SMA canopy species to provide a sustainable source of large woody debris needed for instream channel structure and aquatic species habitat.

1. Applicability

This management measure pertains to lands where silvicultural or forestry operations are planned or conducted. It is intended to apply to surface waters bordering or within the area of operations. SMAs should be established for perennial waterbodies as well as for intermittent streams that are flowing during the time of operation. For winter logging, SMAs are also needed for intermittent streams since spring breakup is both the time of maximum transport of sediments from the harvest unit and the time when highest flows are present in intermittent streams.

Under the Coastal Zone Act Reauthorization Amendments of 1990, States are subject to a number of requirements as they develop coastal nonpoint source programs in conformity with this measure and will have some flexibility in doing so. The application of this management measure by States is described more fully in *Coastal Nonpoint Pollution Control Program: Program Development and Approval Guidance*, published jointly by the U.S. Environmental Protection Agency (EPA) and the National Oceanic and Atmospheric Administration (NOAA) of the U.S. Department of Commerce.

2. Description

The streamside management area (SMA) is also commonly referred to as a streamside management zone (SMZ) or as a riparian management area or zone. SMAs are widely recognized to be highly beneficial to water quality and aquatic habitat. Vegetation in SMAs reduces runoff and traps sediments generated from upslope activities, and reduces nutrients in runoff before it reaches surface waters (Figure 3-9, Kundt and Hall, 1988). Canopy species provide shading to surface waters, which moderates water temperature and provides the detritus that serves as an energy source for stream ecosystems. Trees in the SMA also provide a source of large woody debris to surface waters. SMAs provide important habitat for aquatic organisms (and terrestrial species) while preventing excessive logging-generated slash and debris from reaching waterbodies (Corbett and Lynch, 1985).

SMAs need to be of sufficient width to prevent delivery of sediments and nutrients generated from forestry activities (harvest, site preparation, or roads) in upland areas to the waterbody being protected. Widths for SMAs are established by considering the slope, soil type, precipitation, canopy, and waterbody characteristics. To avoid failure of SMAs, zones of preferential drainage such as intermittent channels, ephemeral channels and depressions need to be addressed when determining widths and laying out SMAs. SMAs should be designed to withstand wind damage or blowdown. For example, a single rank of canopy trees is not likely to withstand blowdown and maintain the functions of the SMA.

SMA should be managed to maintain a sufficient number of large trees to provide for bank stability and a sustainable source of large woody debris. Large woody debris is naturally occurring dead and down woody materials and should not be confused with logging slash or debris. Trees to be maintained or managed in the SMA should provide for large woody debris recruitment to the stream at a rate that maintains beneficial uses associated with fish habitat and stream structure at the site and downstream. This should be sustainable over a time period that is equivalent to that needed for the tree species in the SMA to grow to the size needed to provide large woody debris.

A sufficient number of canopy species should also be maintained to provide shading to the stream water surface needed to prevent changes in temperature regime for the waterbody and to prevent deleterious temperature- or sunlight-related impacts on the aquatic biota. If the existing shading conditions for the waterbody prior to activity are known to be less than optimal for the stream, then SMAs should be managed to increase shading of the waterbody.

To preserve SMA integrity for water quality protection, some States limit the type of harvesting, timing of operations, amount harvested, or reforestation methods used. SMAs are managed to use only harvest and silvicultural methods that will prevent soil disturbance within the SMA. Additional operational considerations for SMAs are addressed in subsequent management measures. Practices for SMA applications to wetlands are described in Management Measure J.

3. Management Measure Selection

a. Effectiveness Information

The effectiveness of SMAs in protecting streams from temperature increases, large increases in sediment load, and reduced dissolved oxygen was demonstrated by Hall and others (1987) (Table 3-10). Lantz (1971) (Table 3-11) also showed the protection that streamside vegetation and selective cutting gave to both water quality and the cutthroat trout population. A comparison of physical changes associated with logging using three streamside treatments was made by Hartman and others (1987) (Table 3-12). This study was performed to observe the impact of these SMAs on the supply of woody debris essential to the fish population and channel structure. The volume and stability of large woody debris decreased immediately in the most intensive treatment area, decreased a few years after logging in the careful treatment area, and remained stable where streamside trees and other vegetation remained.

Other experimental forest studies have found that average monthly maximum water temperature increases from 3.3 to 10.5 °C following clearcutting (Lynch et. al., 1985). Increases in stream temperature result from increased direct solar radiation to the water surface from the removal of vegetative cover or shading in the streamside area. Stream temperature change depends on the height and density of trees, the width of the waterbody, and the volume of water (stream discharge), with small streams heating up faster than large streams per unit of increased solar radiation (Megahan, 1980). Increased direct solar radiation also shifts the energy sources for stream ecosystems from outside the stream sources, allochthonous organic matter, to instream producers, autochthonous aquatic plants such as algae.

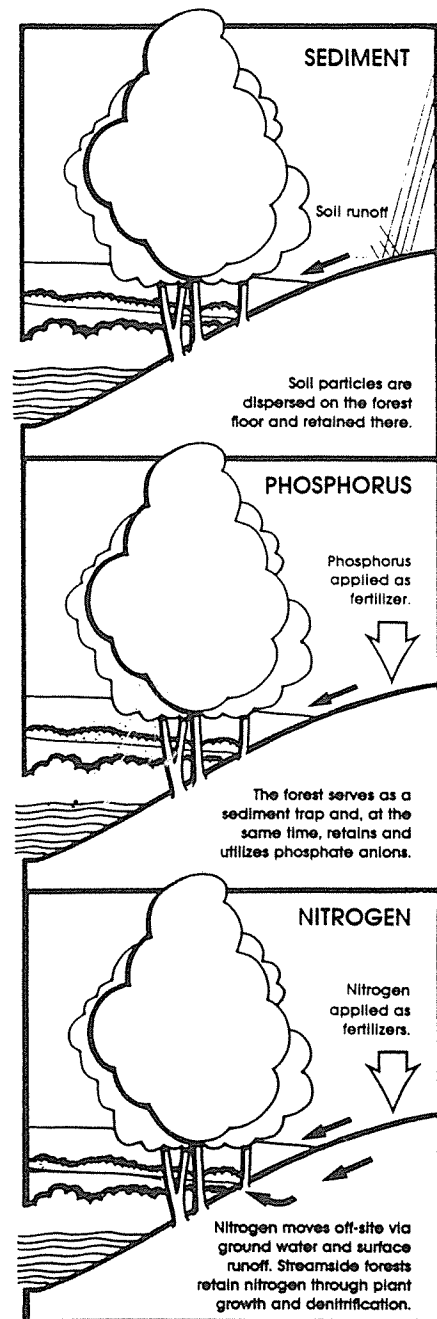

Figure 3-9. SMA pollutant removal processes (Kundt and Hall, 1988).

**Table 3-10. Comparison of Effects of Two Methods of Harvesting on Water Quality (OR)
(Hall et al., 1987)**

Watershed	Method	Streamflow	Water Temp.	Sediment	Dissolved Oxygen
Deer Creek	Patch cut with buffer strips (750 acres)	No increase in peak flow	No change	Increases for one year due to periodic road failure	No change
Needle Branch	Clearcut with no stream protection (175 acres)	Small increases	Large changes, daily maximum increase by 30°F, returning to pre-log temp. within 7 years	Five-fold increase during first winter, returning to near normal the fourth year after harvest	Reduced by logging slash to near zero in some reaches; returned to normal when slash removed

Brown and Krygier (1970) report the greatest long-term average temperature response following clearcutting and slash disposal on a small watershed in Oregon. The average monthly temperature increased 14 °F compared to no increase on an adjacent, larger watershed that was clearcut in patches with 50- to 100-foot-wide buffer strips between the logging units and the perennial streams. Lynch and Corbett (1990) report less than a 3 °F mean temperature increase following harvesting, with 100-foot buffer strips along perennial streams. They attribute the increase to an intermittent stream with no protective vegetation that became perennial after harvesting due to increased flow. As a result of this BMP evaluation study, Pennsylvania modified its BMPs to require SMAs along both perennial and intermittent streams.

Another benefit of streamside management areas is control of suspended sediment and turbidity levels. Lynch and others (1985) documented the effectiveness of SMAs in controlling these pollutants (Table 3-13). A combination of practices was applied, including buffer strips and prohibitions for skidding, slash disposal, and road layout in or near streams. Average stormwater-suspended sediment and turbidity levels for the treatment without these practices increased significantly compared to the control and SMA/BMP sites.

Table 3-11. Water Quality Effects from Two Types of Logging Operations in the Alsea Watershed (OR) (Lantz, 1971)

Watershed and Logging Method	Acreage	Oxygen Content	Temperature	Suspended Sediment	Cutthroat Trout Population
Needle Branch; clearcut, streamside vegetation removed	175	Decrease during summer due to debris in water	Increase of maximum from 61°F to 85°F	Increase (largest contribution from roads)	Decrease from 265 to 65 fish in stream ½ mile
Deer Creek; selection cut, streamside vegetation retained	750 30% harvested	Only minor changes, if any			
Flynn Creek; control	500	No changes			

**Table 3-12. Summary of Major Physical Changes Within Streamside Treatment Areas (BC)
(Hartman et al., 1987)**

	Streamside Treatment						
	Leave Strip ^a			Careful ^b	Intensive ^c		
	II	III	IV	VIII	V	VI	VII
Large Debris							
Mean volume (m ³ /30 m)							
Prelogging	29.6	34.2	37.4	14.3	25.4	26.0	78.2
Postlogging	29.5	50.4	36.4	14.7	23.2	20.0	19.5
Mean number of pieces							
Prelogging	34.0	27.3	32.0	14.2	25.0	25.3	19.8
Postlogging	36.5	27.0	30.0	20.9	27.5	36.2	23.0
Means of stability indices							
Prelogging							
Postlogging	54.7	53.0	84.4	82.0	80.2	93.1	98.9
	63.3	61.7	61.2	39.0	35.7	43.9	56.2
Small Debris							
Volume					Volume not		
Prelogging	--	--	--	--	measured but low.		--
Postlogging	--	--	--	--	Volume increased		--
					after logging and		
					reduced by 90%		
					after 1978 freshet.		

Sources: All results except those on substrate change are from Schultz International (1981) and Toews and Moore (1982). The results on substrate change are from Scrivener and Brownlee (1986).

^a Leave strip treatment included leaving a variable-width strip of vegetation along the stream.

^b Careful treatment involved clearcutting to the margin of the stream and felling of streambank alder, with virtually no in-channel activity.

^c Intensive treatment involved clearcutting to the streambank, felling of streambank alder, some yarding of felled trees, and merchantable blowdown from the stream.

**Table 3-13. Storm Water Suspended Sediment Delivery for Different Treatments (PA)
(Lynch, Corbett, and Mussallem, 1985)**

Water Year and Treatment	Annual Average Suspended Sediment in mg/l (Range)
1977	
Forested control	1.7(0.2 - 8.6)
Clearcut-herbicide	10.4(2.3 - 30.5)
Commercial clearcut with BMPs ^a	5.9(0.3 - 20.9)
1978	
Forested control	5.1(0.3 - 33.5)
Clearcut-herbicide	-- ^b (1.8 - 38.0)
Commercial clearcut with BMPs ^a	9.3(0.2 - 76.0)

^a Buffer strips, skidding in streams prohibited, slash disposal away from streams, skid trail and road layout away from streams.

^b Data not available.

Table 3-14. Average Changes in Total Coarse and Fine Debris of a Stream Channel After Harvesting (OR) (Froehlich, 1973)

Cutting Practice	Natural Debris	Material Added in Felling	% Increase
	(tons per hundred feet of channel)		
Conventional tree-felling	8.1	47	570
Cable-assisted directional felling	16	14	112
Conventional tree-felling with buffer strip ^a	12	1.3	14

^a Buffer strips ranged from 20 to 130 feet wide for different channel segments.

Practices such as directional felling are designed to minimize stream and streambank damage associated with increased logging debris in SMAs. Froehlich (1973) provides data on how effective different cutting practices and buffer strips are in preventing debris from entering the stream channel (Table 3-14). Buffer strips were the most effective debris barriers. Narver (1971) investigated the impacts of logging debris in streams on salmonid production and describes threats to fish embryo survival from low dissolved oxygen concentrations and decreased flow velocities in intragravel waters. Erman and others (1977) studied the effectiveness of buffer strips in protecting aquatic organisms and found significant differences in benthic invertebrate communities when logging occurred with buffer strips less than 30 meters wide.

b. Cost Information

In 4 of the 10 areas in Oregon studied by Dykstra and Froehlich (1976a), the 55-foot buffer strip was the least costly alternative, yet these researchers concluded that no single alternative is preferable for all sites in terms of costs and that cost analysis alone cannot resolve the question of best stream protection method (Table 3-15).

Dykstra and Froehlich (1976b) also found that increased cable-assisted directional felling costs (68 to 108 percent increase) were offset by savings in channel clean-up costs (only 27 percent as much large debris and 39 percent small debris accumulated in the stream for cable-assisted felling), increased yield from reduced breakage, and reduced yarding costs. They also estimated costs for debris removal from streams to be \$300 to clean 5 tons of debris from a 100-foot segment, or about \$60 per ton of residue removed.

Table 3-15. Average Estimated Logging and Stream Protection Costs per MBF^a (OR) (Dykstra and Froehlich, 1976a)

Cutting Practice	Total Cost		Volume Foregone
	Average	Range	
Conventional felling	\$24.78	\$21.90 - 29.93	None
Cable-assisted directional felling (1.43% breakage saved within 200-foot stream)	\$26.05	\$21.36 - 31.24	--
Cable-assisted felling (10% breakage saved)	\$24.64	\$19.55 - 29.82	--
Buffer strip (55 feet wide)	\$23.34	\$19.84 - 27.77	0 to 6 percent
Buffer strip (150 feet wide)	\$27.15	\$24.33 - 30.28	6 to 17 percent

^a Cost estimates for each of 10 areas studied by Dykstra and Froehlich were averaged for this table.

Lickwar (1989) examined the costs of SMAs as determined by varying slope steepness (Table 3-16) in different regions in the Southeast and compared them to road construction and revegetation practice costs. He found SMAs to be the least expensive practice, in general, and to cost roughly the same independent of slope.

The costs associated with use of alternative buffer and filter strips were also analyzed in an Oregon case study (Olsen, 1987) (Table 3-17) and by Ellefson and Weible (1980). In the Oregon case study, increasing the buffer width from 35 feet on each side of a stream to 50 feet was shown to reduce the value per acre by \$103 undiscounted and \$75 discounted costs, approximately a 2 percent increase on a harvesting cost per acre of \$5,163 undiscounted and \$3,237 discounted. Doubling the buffer width from 35 to 70 feet on each side reduced the dollar value per acre by approximately 3 times more, adding approximately 8 percent to the discounted harvesting costs. Ellefson and Weible also analyzed the added cost and rate of return associated with various filter and buffer strip widths. Doubling the width of a filter strip from 30 to 60 feet increases the cost from \$12 to \$44 per sale and reduces the rate of return by 0.4 percent. Doubling the width of the buffer strip from 30 to 60 feet doubles the cost and reduces the rate of return by 1 percent. Increasing the width of the buffer strip from 30 to 100 feet triples the cost and reduces the rate of return by 2.3 percent.

4. Practices

As discussed more fully at the beginning of this chapter and in Chapter 1, the following practices are described for illustrative purposes only. State programs need not require implementation of these practices. However, as a practical matter, EPA anticipates that the management measure set forth above generally will be implemented by applying one or more management practices appropriate to the source, location, and climate. The practices set forth below have been found by EPA to be representative of the types of practices that can be applied successfully to achieve the management measure discussed above.

■ Generally, SMAs should have a minimum width of 35 to 50 feet. SMA width should also increase according to site-specific factors. The primary factors that determine the extension of SMA width are slope, class of watercourse, depth to water table, soil type, type of vegetation, and intensity of management.

Many States use SMAs. Examples of SMA designation strategies from Florida, North Carolina, Maine, and Washington are presented. Figure 3-10 depicts Florida's streamside management zone (SMZ) designations. Florida's SMZs are divided into a fixed-width primary zone and a variable secondary zone, each of which has its own special management criteria. Table 3-18 presents North Carolina's recommendations for SMZ widths for various types of waterbodies dependent on adjacent upland slope. Maine's recommended filter strip widths are dependent on the land

Table 3-16. Cost Estimates (and Cost as a Percent of Gross Revenues) for Streamside Management Areas (1987 Dollars) (Lickwar, 1989)

Practice Component	Steep Sites ^a	Moderate Sites ^b	Flat Sites ^c
Streamside Management Zones	\$2,061.77 (0.52%)	\$2,397.80 (0.51%)	\$2,344.08 (0.26%)

^a Based on a 1,148-acre forest and gross harvest revenues of \$399,68. Slopes average over 9 percent.

^b Based on a 1,104-acre forest and gross harvest revenues of \$473,18. Slopes ranged from 4 percent to 8 percent.

^c Based on a 1,832-acre forest and gross harvest revenues of \$899,49. Slopes ranged from 0 percent to 3 percent.

**Table 3-17. Cost Impacts of Three Alternative Buffer Strips (OR):
Case Study Results with 640-Acre Base (36 mbf/acre) (Olsen, 1987)**

	Scenario		
	I	II	III
Average buffer width (feet on each side)	35	50	70
Percent conifers removed	100	60	25
Percent reclassified Class II streams ^b	0	20	80
Harvesting restrictions	Current	New	New
<u>Road Construction</u>			
New miles	2.09	2.14	3.06
Road and landing acres	10.9	11.1	15.9
Cost total (1000's)	\$96.00	\$102.00	\$197.00
Cost/acre	\$149.00	\$160.00	\$307.00
<u>Harvesting Activities^c</u>			
mmbf harvested	22.681	22.265	20.277
Acres harvested	638.3	635.5	633.1
Cost total (1000's)	\$3,104.00	\$3,101.00	\$2,842.00
Cost/acre	\$4,841.00	\$4,835.00	\$4,432.00
Cost/mbf	\$136.87	\$139.26	\$140.17
<u>Inaccessible Area and Volume</u>			
Percent area in buffers	1.3	3.9	14.0
mmbf left in buffers	0.000	0.313	2.214
Acres unloggable	1.44	4.32	6.72
mmbf lost to roads and landings	0.202	0.205	0.295
<u>Undiscounted Costs (1000's)</u>			
Road cost	\$96.00	\$102.00	\$197.00
Harvesting cost	\$3,104.00	\$3,101.00	\$2,842.00
Value of volume foregone ^d	\$38.00	\$101.00	\$413.00
Total	\$3,238.00	\$3,304.00	\$3,451.00
Cost/acre	\$5,060.00	\$5,163.00	\$5,393.00
Reduced dollar value/acre	—	\$103.00	\$323.00
<u>Discounted Costs</u>			
Cost with 4% discount rate (1000's)	\$2,023.00	\$2,071.00	\$2,195.00
Cost/acre	\$3,162.00	\$3,237.00	\$3,431.00
Reduced value/acre	—	\$75.00	\$269.00

mmbf = million board feet; mbf = thousand board feet

^a 1986 dollars.

^b Generally, only Class I streams are buffered.

^c Includes felling, landing construction and setup, yarding, loading, and hauling.

^d Volume foregone x net revenue (\$150/mbf).

slope between the road and waterbody (Table 3-19). Washington State requires a riparian management zone (RMZ) around all Type 1, 2, and 3 waters where the adjacent harvest cutting is a regeneration cut or a clearcut. A guide for calculating the average width of the RMZ is provided in the Forest Practices Board manual (Washington State Forest Practices Board, 1988)(Figure 3-11).

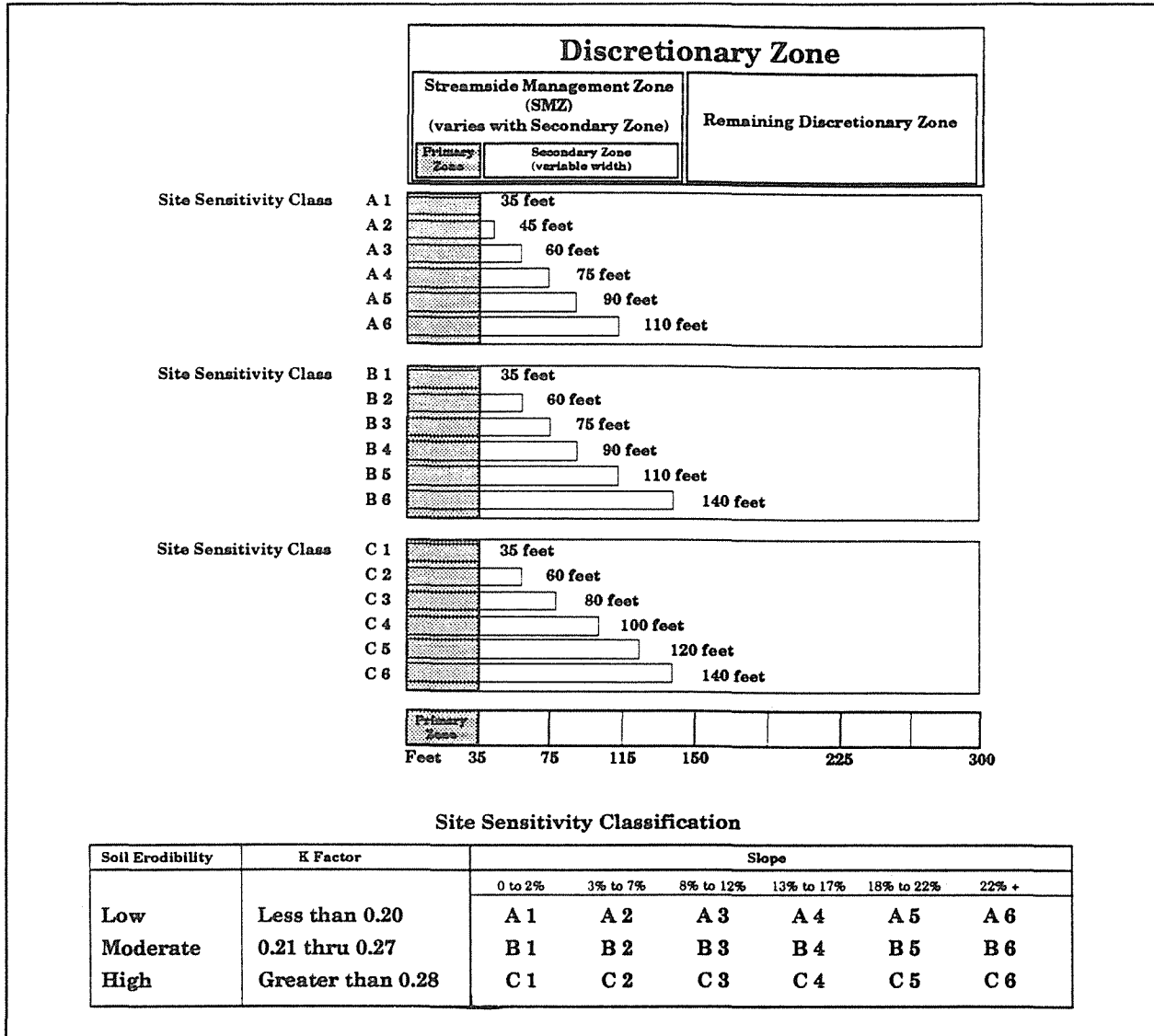

Figure 3-10. Florida's streamside management zone widths as defined by the Site Sensitivity Classification (Florida Department of Agriculture and Consumer Services, Division of Forestry, 1991).

- Minimize disturbances that would expose the mineral soil of the SMA forest floor. Do not operate skidders or other heavy machinery in the SMA.
- Locate all landings, portable sawmills, and roads outside the SMA.
- Restrict mechanical site preparation in the SMA, and encourage natural revegetation, seeding, and handplanting.
- Limit pesticide and fertilizer usage in the SMA. Buffers for pesticide application should be established for all flowing streams.

**Table 3-18. Recommended Minimum SMZ Widths
(North Carolina Division of Forest Resources, 1989)**

Type of Stream or Waterbody	Percent Slope of Adjacent Lands				
	0-5	6-10	11-20	21-45	46+
	SMZ Width Each Side (feet)				
Intermittent	50	50	50	50	50
Perennial	50	50	50	50	50
Perennial Trout Waters	50	66	75	100	125
Public Water Supplies (Streams and Reservoirs)	50	100	150	150	200

■ *Directionally fell trees away from streams to prevent logging slash and organic debris from entering the waterbody.*

■ *Apply harvesting restrictions in the SMA to maintain its integrity.*

Enough trees should be left to maintain shading and bank stability and to provide woody debris. This provision for leaving residual trees can be accomplished in a variety of ways. For example, the Maine Forestry Service (1991) specifies that no more than 40 percent of the total volume of timber 6 inches DBH and greater should be removed in a 10-year period, and the trees removed should be reasonably distributed within the SMA. Florida (1991) recommends leaving a volume equal to or exceeding one-half the volume of a fully stocked stand. The number of residual trees varies inversely with their average diameter (Table 3-20). A shading requirement independent of the volume of timber may be necessary for streams where temperature changes could alter aquatic habitat.

Studies by Brazier and Brown (1973) demonstrated that the effectiveness of the SMA in controlling temperature changes is independent of timber volume; it is a complex interrelationship between canopy density, canopy height, stream width, and stream discharge. The Washington State Forest Practices Board (1988) incorporates leave tree and shade requirements in its regulations (Figure 3-12). Shade requirements within the SMA are to leave all nonmerchantable timber that provides midsummer and midday shade to the water surface, and to leave sufficient merchantable timber necessary to retain 50 percent of the summer midday shade. Shade cover is preferably left distributed evenly within the SMA (Figure 3-13). If a threat of blowdown exists, then clumping and clustering of leave trees may be used as long as the shade requirement is met (Figure 3-14).

Table 3-19. Recommendations for Filter Strip Widths (Maine Forest Service, 1991)

Slope of Land (%)	Width of Strip (ft along ground)
0	25
10	45
20	65
30	85
40	105
50	125
60	145
70	165

Guidelines for Calculating Average Width of Riparian Management Zones (RMZ)

Use the following procedures to calculate average width of Eastern Washington riparian management zone (RMZ) when the adjacent harvest cutting is a regeneration cut or clearcut. Average RMZ width is also used to calculate the acreage and number of trees/acre. (See WAC 222-16-010(33) Partial Cut.)

Procedures

1. RMZs are measured separately on each side of streams. Begin at the ordinary high water mark of Type 1, 2 and 3 Waters and measure the horizontal distance to the line where vegetation changes from wetland to upland type, EXCEPT where the distance is less than the minimum or greater than the maximum widths in the rules. (See 7 below and Figure 14.)
2. Width measurements (horizontal distance) are taken at right angles to the stream reach. See WAC 222-30-020(6) for description of Eastern Washington RMZ. Western Washington RMZ is described in WAC 222-30-020(5).
3. Measure width of RMZ at 5 or more similarly spaced intervals.
4. Use 50 feet or greater distance between width measurements. Sample the entire stream reach within the harvest unit.
5. On each end of the stream reach being measured, begin and end width measurements at one-half the interval used for the other measurements. This helps to reduce sampling errors.
6. If the RMZ width varies more than 30 feet in a set of measurements, increase the number of measurements. Try for uniform sampling. Use enough measurements to adequately sample natural variations in width. (See Figure 14.)
7. On Eastern Washington PARTIAL CUTS, a width of less than 30 feet is noted as 30 feet and a width of more than 50 feet is noted as 50 feet when calculating the average RMZ width for leave trees/acre because these distances are specified in the rules. The natural riparian area may be wider or narrower than stated in the rules.

For other types of cuts, minimum width is measured in the same way as for partial cuts. But the actual width of more than 30 feet is noted up to a maximum of 300 feet. If the riparian area is wider than 300 feet, it is noted as 300 feet.
8. Calculate average width by totaling the widths in feet and dividing by the number of measurements.
9. In Eastern Washington where the adjacent harvest is a regeneration cut or clearcut, RMZs must AVERAGE 50 feet in width.
10. Multiply average RMZ width by its length within the cutting unit to calculate square feet of RMZ. Measure length approximately parallel to stream reach and near outer edge of RMZ.
11. Multiply square feet by 0.000023 to calculate acres or see Acreage Table 6. (Figure 15 describes leave trees and snags for Eastern Washington RMZ.)

Figure 14. Eastern Washington Riparian Management Zone (RMZ)

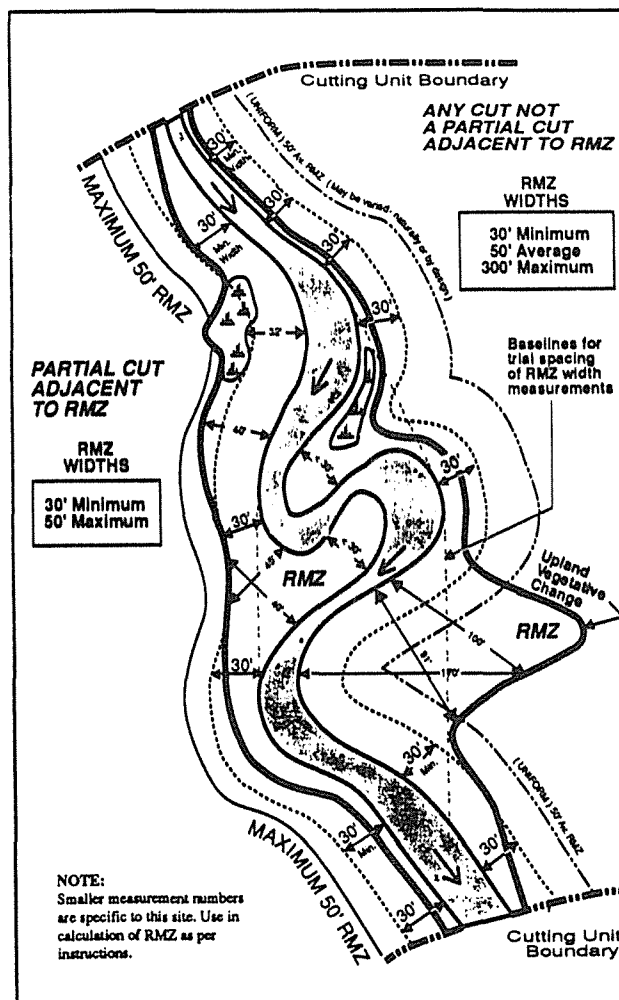

Figure 3-11. Guide for calculating the average width of the RMZ (Washington State Forest Practices Board, 1988).

Table 3-20. Stand Stocking in the Primary SMZ (Florida Department of Agriculture and Consumer Services, Division of Forestry, 1991)

Average Tree Size (DBH)	Minimum Number of Trees per 100 feet	Average Tree Spacing (feet)
Small (2" to 6")	18	14
Medium (8" to 12")	7	23
Large (14"+)	3	34

Design for Leave Trees and Snags/Acre - Type 1, 2 and 3 Water
 (50 percent of ALL leave trees are to be live at completion of harvest.)

#/Ac.	Cond.	Species	Size by dbh	Other Design Criteria
All	Live	Trees	12" or less,	AND
All*	Dead	Snags	All, *(exc. those in viol. L & I Rules)	
			AND	
16	Live	Conifers	12 - 20" distr. x size repr. of stand,	
			AND	
3	Live	Conifers	20" or larger,	AND
[2	Live	Deciduous	Largest trees 16" & larger,	EXCEPT]
[Where 2 Live Deciduous Trees 16" dbh & larger do NOT exist,	AND]
[2 Dead Snags 20" dbh & larger do not exist,]]
[SUBSTITUTE]]
[2	Live	Conifers	20" or larger, IF these do NOT exist,]]
[SUBSTITUTE]]
[5	Live	Conifers	Largest available,]]
			AND	
3	Live	Deciduous	12 - 16", IF they exist in the RMZ, AND	

ADDITIONAL Trees to Total the Minimum Number of Leave Trees:

Adjacent Type of Cut*	Measured 1 Side Width of RMZ			Number of Trees/Acre by Type of Bed	
	Min.	Max.	AV.	Gravel/Cobble (<10" diameter)	Boulder/Bedrock (& lake & pond)
	30'	50'	DNA**	135, 4" dbh & >	75, 4" dbh & >
Partial	30'	50'	DNA**	135, 4" dbh & >	75, 4" dbh & >
Other	30'	300'	50'	135, 4" dbh & >	75, 4" dbh & >

*(See definition, regeneration cuts of any type are NOT Partial.)
 **Does not apply.

Figure 3-12. Washington State Forest Practices Board (1988) requirements for leave trees in the RMZ.

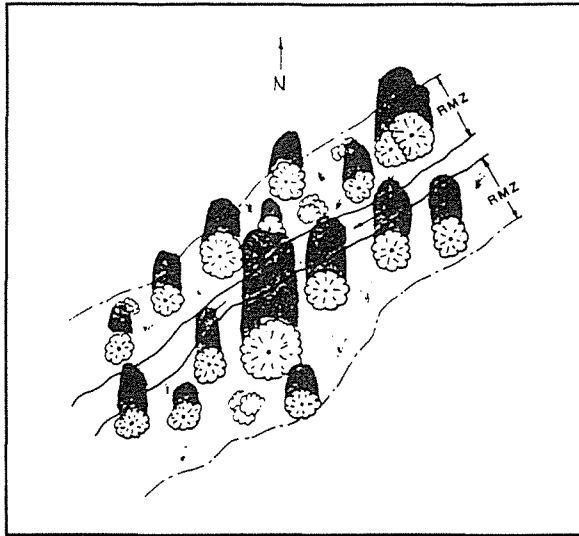

Figure 3-13. Uniform harvesting in the riparian zone (Washington State Forest Practices Board, 1988).

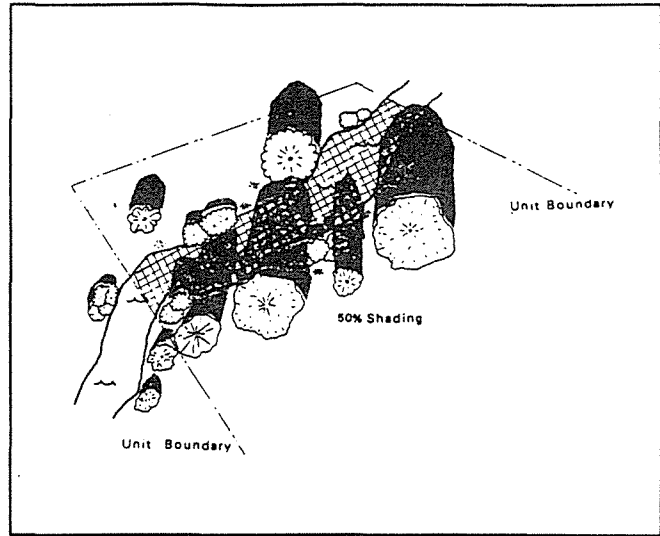

Figure 3-14. Vegetative shading along a stream course (Washington State Forest Practices Board, 1988).

C. Road Construction/Reconstruction

- (1) Follow preharvest planning (as described under Management Measure A) when constructing or reconstructing the roadway.
- (2) Follow designs planned under Management Measure A for road surfacing and shaping.
- (3) Install road drainage structures according to designs planned under Management Measure A and regional storm return period and installation specifications. Match these drainage structures with terrain features and with road surface and prism designs.
- (4) Guard against the production of sediment when installing stream crossings.
- (5) Protect surface waters from slash and debris material from roadway clearing.
- (6) Use straw bales, silt fences, mulching, or other favorable practices on disturbed soils on unstable cuts, fills, etc.
- (7) Avoid constructing new roads in SMAs to the extent practicable.

1. Applicability

This management measure is intended for application by States on lands where silvicultural or forestry operations are planned or conducted. It is intended to apply to road construction/reconstruction operations for silvicultural purposes, including:

- The clearing phase: clearing to remove trees and woody vegetation from the road right-of-way;
- The pioneering phase: excavating and filling the slope to establish the road centerline and approximate grade;
- The construction phase: final grade and road prism construction and bridge, culvert, and road drainage installation; and
- The surfacing phase: placement and compaction of the roadbed, road fill compaction, and surface placement and compaction (if applicable).

Under the Coastal Zone Act Reauthorization Amendments of 1990, States are subject to a number of requirements as they develop coastal nonpoint source programs in conformity with this measure and will have some flexibility in doing so. The application of this management measure by States is described more fully in *Coastal Nonpoint Pollution Control Program: Program Development and Approval Guidance*, published jointly by the U.S. Environmental Protection Agency (EPA) and the National Oceanic and Atmospheric Administration (NOAA) of the U.S. Department of Commerce.

2. Description

The goal of this management measure is to minimize delivery of sediment to surface waters during road construction/reconstruction projects. Figure 3-15 depicts various road structures addressed by this management measure. Disturbance of soil and rock during road construction/reconstruction creates a significant potential for erosion and sedimentation of nearby streams and coastal waters. Some roads are temporary or seasonal-use roads.

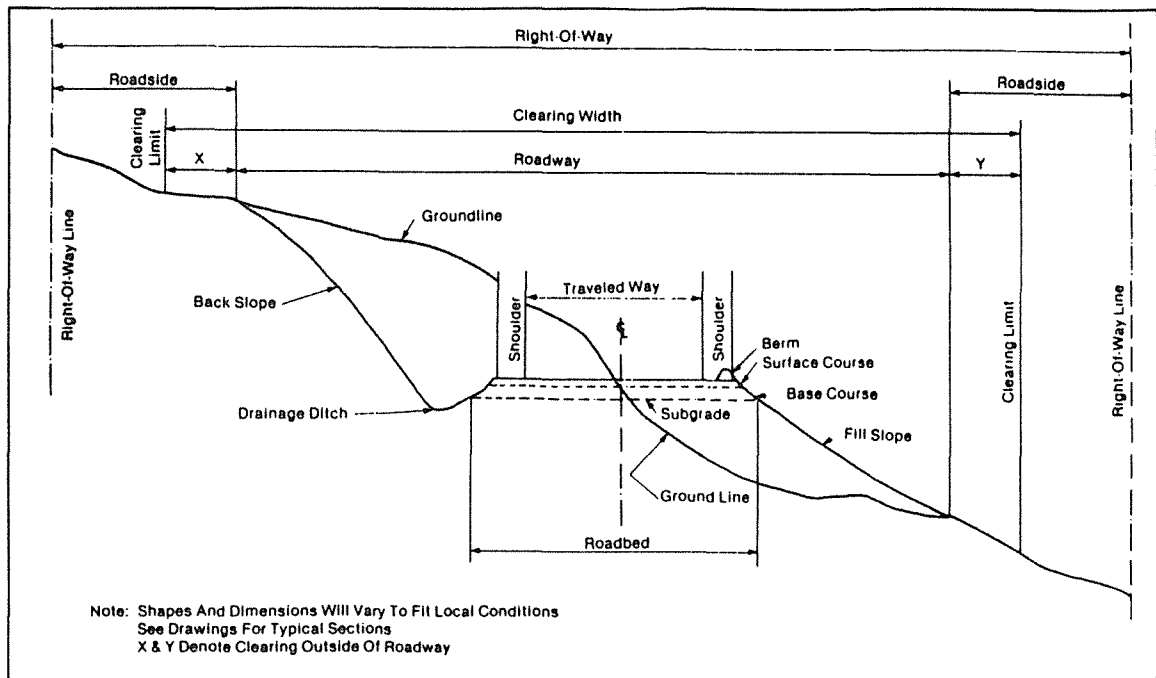

Figure 3-15. Illustration of road structure terms (Hynson et al., 1982).

and their construction does not involve the high level of disturbance generated by permanent, high-standard roads. However, temporary or low-standard roads still need to be constructed in such a way as to prevent disturbance and sedimentation. Brown (1972) stated that road construction is the largest source of silviculture-produced sediment in the Pacific Northwest. It is also a significant source in other regions of the country. Therefore, proper road and drainage crossing construction practices are necessary to minimize sediment delivery to surface waters. Proper road design and construction can prevent road fill and road backslope failure, which can result in mass movements and severe sedimentation. Proper road drainage prevents concentration of water on road surfaces, thereby preventing road saturation that can lead to rutting, road slumping, and channel washout (Dyrness, 1967; Golden et al., 1984). Proper road drainage during logging operations is especially important because that is the time when erosion is greatly accelerated by continuous road use (Kochenderfer, 1970). Figure 3-16 presents various erosion and sediment control practices.

Surface protection of the roadbed and cut-and-fill slopes can:

- Minimize soil losses during storms;
- Reduce frost heave erosion production;
- Restrain downslope movement of soil slumps; and
- Minimize erosion from softened roadbeds (Swift, 1984).

Although there are many commonly practiced techniques to minimize erosion during the construction process, the most meaningful are related to how well the work is planned, scheduled, and controlled by the road builder and those responsible for determining that work satisfies design requirements and land management resource objectives (Larse, 1971).

3. Management Measure Selection

Most erosion from road construction occurs within a few years of disturbance (Megahan, 1980). Therefore, erosion control practices that provide immediate results (such as mulching or hay bales) should be applied as soon as possible to minimize potential erosion (Megahan, 1980). King (1984) found that the amount of sediment produced by road construction was directly related to the percent of the area taken by roads, the amount of protection given to the seeded slopes, and whether the road is given a protective surface (Table 3-21).

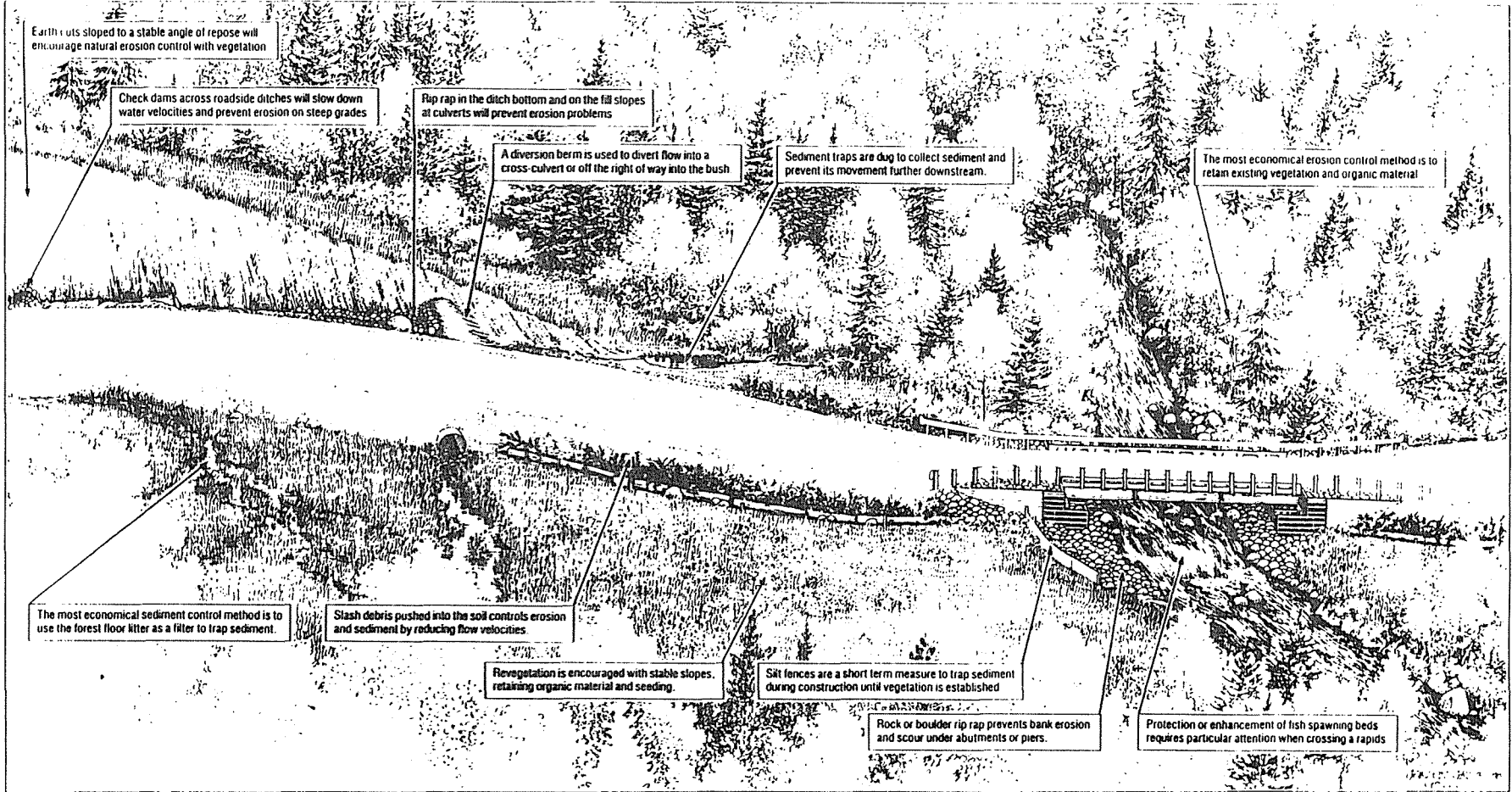

Figure 3-16. Mitigation techniques used for controlling erosion and sediment to protect water quality and fish habitat (Ontario Ministry of Natural Resources, 1988).

**Table 3-21. Effects of Several Road Construction Treatments on Sediment Yield (ID)
King (1984)**

Watershed Area (acres)	Area in Roads (percent)	Treatment	Increase of Annual Sediment Yield ^a (percent)
207	3.9	Unsurfaced roads; Untreated cut slope; Untreated fill slope	156
161	2.6	Unsurfaced roads; Untreated cut slope dry seeded	130
364	3.7	Surfaced roads; Cut and fill slopes straw mulched and seeded	93
154	1.8	Surfaced roads; Filter windrowed; Cut and fill slopes straw mulched and seeded	53
70	3.0	Surfaced roads; Filter windrowed; Cut and fill slopes hydro-mulched and seeded	25
213	4.3	Surfaced roads; Filter windrowed; Cut and fill slopes hydro-mulched and seeded	19

^a Measured in debris basins.

a. Effectiveness Information

The effectiveness of road surfacing in controlling erosion was demonstrated by Kochenderfer and Helvey (1984)(Table 3-22). The data show that using 1-inch crusher-run gravel or 3-inch clean gravel can reduce erosion to less than one-half that of using 3-inch crusher run gravel and to 12 percent that of an ungraveled road surface.

According to Swift (1984b), road cuts and fills are the largest source of sediment once a logging road is constructed. His research showed that planting grass on cut-and-fill slopes of new roads effectively reduced erosion in the southern Appalachians. The combined effectiveness of grass establishment and roadbed graveling was a 97-99 percent reduction in soil loss.

Swift (1986) measured the extent of downslope soil movement for various categories of roadway and slope conditions (Tables 3-23 and 3-24). He found that grassed fill was more effective than mulched fill or bare fill in reducing the downslope movement of soil from newly constructed roads. The author determined grass, forest floor litter, and brush barriers to be effective management practices for reducing downslope sediment.

Megahan (1980, 1987) summarized the results of several studies that echo Swift's conclusions (Table 3-25). The combination of straw mulch with some type of netting to hold it in place reduces erosion by more than 90 percent and has the added benefits of providing immediate erosion control and promoting revegetation. Treating the road surface reduced erosion 70 to 99 percent. Grass seeding alone can control erosion in moist climates, as confirmed by Swift (1984b).

Table 3-22. Effectiveness of Road Surface Treatments in Controlling Soil Losses (WV) (Kochenderfer and Helvey, 1984)

Surface Treatment	Average Annual Soil Losses (tons/acre) ^a
3-inch clean gravel	5.4
Ungraveled	44.4
3-inch crusher-run gravel	11.4
1-inch crusher-run gravel	5.5

^a Six measurements taken over a 2-year time period.

b. Cost Information

The costs associated with construction of rolling dips on roads were estimated by Dubensky (1991) as \$19.75 each, with more dips needed as the slope of the road increases.

Ellefson and Miles (1984) determined the decline in net revenue associated with culvert construction, water bar construction, and construction of broad-based dips to be 3.8 percent, 2.3 percent, and 2.4 percent, respectively, for a timber sale with net revenue of \$124,340 without these practices. Kochenderfer and Wendel (1980) examined road costs, including bulldozing, construction of drainage dips, culvert installation, and graveling. They concluded that:

- (1) Cost to reconstruct a road (including 600 tons of 3-inch clean stone surfacing at \$5.74/ton) = \$5,855 *per mile*. Cost also included 20.5 hours (25 hours/mile) of D-6 tractor time (for road construction and construction of broad-based drainage dips), 23 hours (28 hours/mile) of JD 450 tractor time to spread gravel and do final dip shaping, and installation of two culverts. Road construction without the stone would have cost \$1,061/*mile*.
- (2) Cost for a newly constructed road was \$3,673 *per mile*, including 200 tons of gravel. Costs included 46.5 hours (57 hours/mile) of D-6 tractor time to bulldoze the road and construct 22 drainage dips. Spreading gravel and final dip shaping required 7.5 hours of JD tractor time. This road, constructed without stone, would have cost \$2,078 *per mile*.

The study concluded that road construction costs in terrain similar to the West Virginia mountain area would range from about \$2,000/mile with no gravel and few culverts to about \$10,000/mile with complete graveling and more frequent use of culverts.

Kochenderfer, Wendel, and Smith (1984) examined the costs associated with road construction of four minimum standard roads in the Appalachians (Table 3-8 gives road characteristics). Excavation costs varied according to site-specific factors (soil type, rock outcrop extent, topography) and increased as the amount of rock needing blasting and the number of large trees to be removed increased. Culvert costs varied according to the size and type of culvert used (Tables 3-26 and 3-27).

Lickwar (1989) studied the costs of various forestry practices in the Southeast. He determined that practices associated with road construction were generally the most expensive, regardless of terrain. The costs for broad-based dips and water bars increased as the terrain steepened, indicating increased implementation of erosion and runoff control practices as slopes increased (Table 3-28). Steeper areas also required additional (nonspecified) road costs that were not necessary in moderate to flat areas.

Table 3-23. Reduction in the Number of Sediment Deposits More Than 20 Feet Long by Grass and Forest Debris (Swift, 1986)

Degree of Soil Protection	Number of Deposits Per 1,000 Feet of Road
Grassed fill, litter and brush burned	13.9
Bare fill, forest litter	9.9
Mulched fill, forest litter	8.1
Grassed fill, forest litter, no brush barrier	6.9
Grassed fill, forest litter, brush barrier	4.5

Table 3-24. Comparison of Downslope Movement of Sediment from Roads for Various Roadway and Slope Conditions (Swift, 1986)

Comparisons	Sites (no.)	Mean Slope (%)	Distance (feet)		
			Mean	Max	Min
All sites	88	46	71	314	2
Barrier ^a					
Brush barriers	26	46	47	156	3
No brush barrier	62	47	81	314	2
Drainage ^b					
Culvert	21	40	80	314	30
Outsloped without culvert	56	47	63	287	2
Unfinished roadbed with berm	11	57	95	310	25
Grass fill and forest litter ^c	46	40	45	148	2
With brush barrier	16	39	34	78	3
With culvert	4	20	37	43	30
Without culvert	12	45	32	78	3
Without brush barrier	30	41	51	148	2
With culvert	7	37	58	87	30
Without culvert	23	42	49	148	2

^a Examined the effectiveness of leaving brush barriers in place below road fills, rather than removing brush barriers.

^b Compared roads where storm water was concentrated at a culvert pipe to outsloped roads without a culvert. The berm was constructed on an unfinished roadbed to prevent downslope drainage.

^c Compared effectiveness of brush barriers versus drainage (i.e., culvert) systems.

**Table 3-25. Effectiveness of Surface Erosion Control on Forest Roads
(Megahan, 1987, 1980)**

Stabilization Measure	Portion of Road Treated	Percent Decrease in Erosion ^a	Reference
Tree planting	Fill slope	50	Megahan, 1974b
Hydromulch, straw mulch, and dry seeding ^b	Fill slope	24 to 58	King, 1984
Grass and legume seeding	Road cuts	71	Dyrness, 1970
Straw mulch	Fill slope	72	Bethlahmy and Kidd, 1966
Straw mulch	Road fills	72	Ohlander, 1964
Wood chip mulch	Road fills	61	Bethlahmy and Kidd, 1966
Wood chip mulch	Fill slope	61	Ohlander, 1964
Excelsior mulch	Fill slope	92	Burroughs and King, 1985
Paper netting	Fill slope	93	Ohlander, 1964
Asphalt-straw mulch	Fill slope	97	Ohlander, 1964
Straw mulch, netting, and planted trees	Fill slope	98	Megahan, 1974b
Straw mulch and netting	Fill slope	99	Bethlahmy and Kidd, 1966
Gravel surface	Road tread	70	Burroughs and King, 1985
Dust oil	Road tread	85	Burroughs and King, 1985
Bituminous surfacing	Road treated	99	Burroughs and King, 1985
Terracing	Cut slope	86	Unpublished data ^c
Straw mulch	Cut slope	32 to 47	King, 1984
Straw mulch	Cut slope	97	Dyrness, 1970

^a Percent decrease in erosion compared to similar, untreated sites.

^b No difference in erosion reduction between these three treatments.

^c Intermountain Forest and Range Experiment Station, Forestry Sciences Laboratory, Boise, ID.

Unit cost comparisons for surfacing practices (Swift, 1984a) reveal that grass is the least expensive alternative, at \$174 per kilometer of road (Table 3-29). Five-centimeter crushed rock cost almost \$2000 per kilometer, 15-centimeter gravel cost about \$6000, and 20-centimeter gravel cost almost \$9000. The author cautions, however, that material costs alone are misleading because an adequate road surface might endure several years of use, whereas a grassed or thinly-graveled surface would need replenishing. Even so, multiple grass plantings may be cheaper and more effective than gravel spread thinly over the roadbed, depending on climate, growing conditions, soil type, and road use (Swift, 1984b). Megahan (1987) found that dry seeding alone cost significantly less than seeding in conjunction with plastic netting (Table 3-30).

Table 3-26. Cost Summary for Four "Minimum-Standard" Forest Truck Roads Constructed in the Central Appalachians^a (1984 Dollars) (Kochenderfer, Wendel, and Smith, 1984)

Road No.	Costs (dollars/mile)			
	Excavation	Culvert	Labor & Vehicle	Total
1	2,900	371	1,092	5,048
6	4,200	1,043	1,947	7,805
7	5,650	1,143	2,116	9,629
8	3,950	0	722	5,457

^a Costs and time rounded to nearest whole number.

Table 3-27. Unit Cost Data for Culverts (Kochenderfer, Wendel, and Smith, 1984)

Culvert Type	Cost
15-inch gasoline pipe (30-foot sections)	\$7.50/ft
15-inch galvanized	\$6.00/ft
18-inch galvanized	\$7.75/ft
36-inch galvanized	\$19.00/ft

Table 3-28. Cost Estimates (and Cost as a Percent of Gross Revenues) for Road Construction (1987 Dollars) (Lickwar, 1989)

Practice Component	Location					
	Steep Sites ^a		Moderate Sites ^b		Flat Sites ^c	
Stream crossings	\$31.74	(0.01%)	\$128.74	(0.03%)	\$2,998.74	(0.33%)
Broad-based dips	\$11,520	(2.88%)	\$7,040.00	(1.49%)	\$3,240.00	(0.36%)
Water bars	\$8,520	(2.13%)	\$4,440.00	(0.94%)	\$2,160	(0.24%)
Added road costs	\$3,990	(1.00%)	Not Provided		Not Provided	

^a Based on a 1,148-acre forest and gross harvest revenues of \$399,685. Slopes average over 9 percent.

^b Based on a 1,104-acre forest and gross harvest revenues of \$473,182. Slopes ranged from 4 percent to 8 percent.

^c Based on a 1,832-acre forest and gross harvest revenues of \$899,491. Slopes ranged from 0 percent to 3 percent.

Table 3-29. Cost of Gravel and Grass Road Surfaces (NC, WV) (Swift, 1984a)

Surface	Requirements/km	Unit Cost	Total Cost/km
Grass	28 kg Ky-31	\$0.840/kg	\$23.52
	14 kg rye	\$0.660/kg	\$9.24
	405 kg 10-10-10	\$0.121/kg	\$49.01
	900 kg lime	\$0.033/kg	\$29.70
	Labor and equipment	\$62.14/km	\$62.14
Crushed rock (5 cm) ^a	425 ton	\$4.680/ton	\$1,989
Crushed rock (15 cm) ^a	1,275 ton	\$4.680/ton	\$5,967
Large stone (20 cm) ^a	1,690 ton	\$5.240/ton	\$8,856

^a Values in parentheses are thickness or depth of surfacing material.

Table 3-30. Costs of Erosion Control Measures (ID) (Megahan, 1987)

Measure	Cost (\$/acre)
Dry seeding	124
Plastic netting placed over seeded area	5,662

Source: Haber, D.F., and T. Kadoch, 1982. Costs of Erosion Control Measures Used on a Forest Road in the Silver Creek watershed in Idaho, University of Idaho, Dept. of Civil Engineering.

4. Practices

As discussed more fully at the beginning of this chapter and in Chapter 1, the following practices are described for illustrative purposes only. State programs need not require implementation of these practices. However, as a practical matter, EPA anticipates that the management measure set forth above generally will be implemented by applying one or more management practices appropriate to the source, location, and climate. The practices set forth below have been found by EPA to be representative of the types of practices that can be applied successfully to achieve the management measure described above.

- *Follow the design developed during preharvest planning to minimize erosion by properly timing and limiting ground disturbance operations.*
- *Construct bridges and install culverts during periods when streamflow is low.*
- *Avoid construction during egg incubation periods on streams with important spawning areas.*
- *Practice careful equipment operation during road construction to minimize the movement of excavated material downslope as unintentional sidecast.*
- *Compact the road base at the proper moisture content, surfacing, and grading to give the designed road surface drainage shaping.*

■ Use straw bales, straw mulch, grass-seeding, hydromulch, and other erosion control and revegetation techniques to complete the construction project. These methods are used to protect freshly disturbed soils until vegetation can be established.

■ Prevent slash from entering streams or promptly remove slash that accidentally enters streams to prevent problems related to slash accumulations.

Slash can be useful if placed as windrows along the base of the fill slope. Right-of-way material that is merchantable can also be used by the operator.

■ Use turnouts, wing ditches, and dips to disperse runoff and reduce road surface drainage from flowing directly into watercourses.

■ Install surface drainage controls to remove stormwater from the roadbed before the flow gains enough volume and velocity to erode the surface. Route discharge from drainage structures onto the forest floor so that water will disperse and infiltrate (Swift, 1985). Methods of road surface drainage include:

- **Broad-based Dip Construction.** A broad-based dip is a gentle roll in the centerline profile of a road that is designed to be a relatively permanent and self-maintaining water diversion structure and can be traversed by any vehicle (Swift, 1985, 1988) (See Figure 3-17). The dip should be outsloped 3 percent to divert stormwater off the roadbed and onto the forest floor, where transported soil can be trapped by forest litter (Swift, 1988). Broad-based dips should be used on roads having a gradient of 10 percent or less. Proper construction requires an experienced bulldozer operator (Kochenderfer, 1970).
- **Installation of Pole Culverts and/or Ditch Relief Culverts.** Culverts are placed at varying intervals in a road to safely conduct water from the ditch to the outside portion of the road. Figures 3-18 and 3-19 highlight the design and installation of pole and pipe culverts, respectively. Culverts often need outlet and inlet protection to keep water from scouring away supporting material and to keep debris from plugging the culvert. Energy dissipators, such as riprap and slash, should be installed at culvert outlets (Rothwell, 1978). Culvert spacing depends on rainfall intensity, soil type, and road grade. Culvert size selection should be based on drainage area size and should be able to handle large flows. Open-top or pole culverts are temporary drainage structures that are most useful for intercepting runoff flowing down road surfaces (Kochenderfer, 1970). They can also be used as a substitute for pipe culverts on roads of smaller operations, if properly built and maintained, but they should not be used for handling intermittent or live streams. Open-top culverts should be placed at angles across a road to provide gradient to the culvert and to ensure that no two wheels of a vehicle hit the ditch at once.
- **Road Outsloping and Grading.** Grade and outslope roadbeds to minimize water accumulation on road surfaces (Kochenderfer, 1970). This practice minimizes erosion and road failure potential. Outsloping involves grading the road so that it slopes downward from the toe of the road cut to the shoulder. The

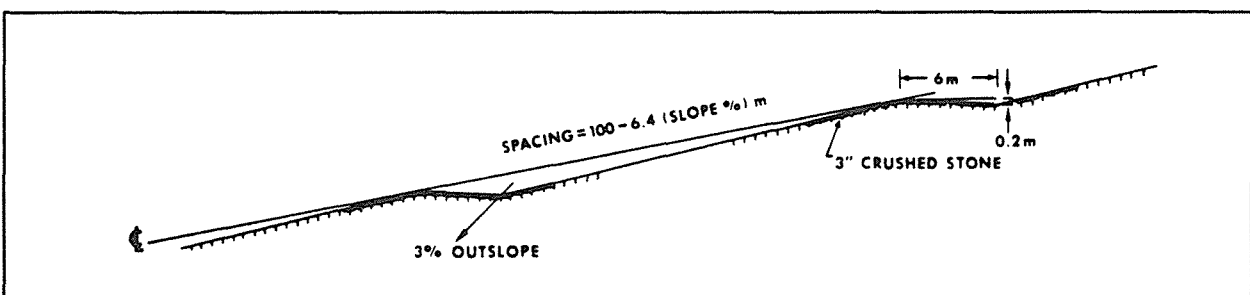

Figure 3-17. Diagram of broad-based dip design for forest access roads (Swift, 1985).

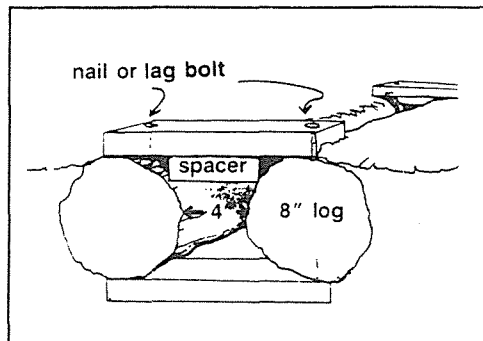

Figure 3-18. Design of pole culverts (Vermont Department of Forests, Parks and Recreation, 1987).

slope should be about 3-4 percent (Rothwell, 1978). Outsloping the roadbed keeps water from flowing next to and undermining the cut bank, and is intended to spill water off the road in small volumes at many random sites. In addition to outsloping the roadbed, a short reverse grade should be constructed to turn water off the surface. Providing a berm on the outside edge of an outsloped road during construction, and until loose fill material is protected by vegetation, can eliminate fill erosion (Swift, 1985). The effectiveness of outsloping is limited by roadbed rutting during wet conditions. Also, berms may form along the edge of older roadbeds and block drainage (Swift, 1985). Therefore, proper maintenance of these structures is necessary.

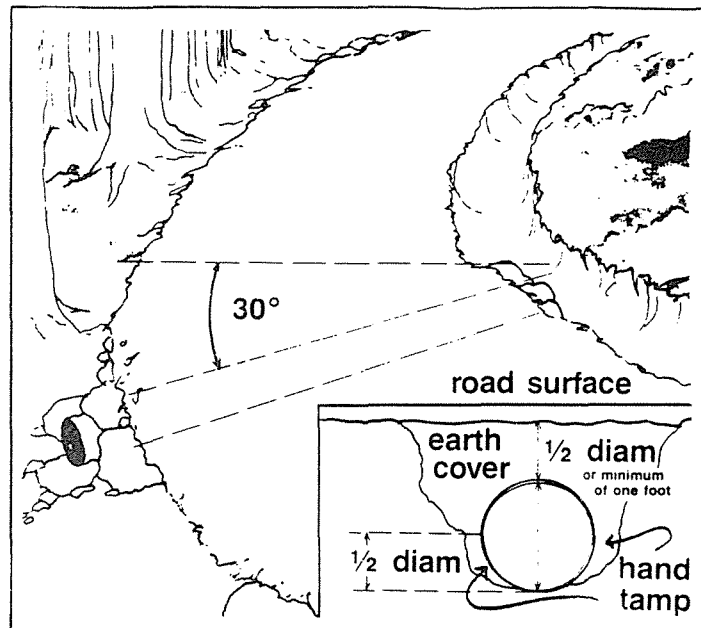

Figure 3-19. Design and installation of pipe culverts (Vermont Department of Forests, Parks and Recreation, 1987).

- **Ditch and Turnout Construction.** Ditches should be used only where necessary and should discharge water into vegetated areas through the use of turnouts. The less water ditches carry and the more frequently water is discharged, the better. Construct wide, gently sloping ditches, especially in areas with highly erodible soils. Ditches should be stabilized with rock and/or vegetation (Yoho, 1980) and outfalls protected with rock, brush barriers, live vegetation, or other means. Roadside ditches should be large enough to carry runoff from moderate storms. A standard ditch used on secondary logging roads is a triangular section 45 cm deep, 90 cm wide on the roadway side, and 30 cm wide on the cut bank side. Minimum ditch gradient should be 0.5 percent, but 2 percent is preferred to ensure good drainage. Runoff should be frequently diverted into culverts to prevent erosion or overflow (Rothwell, 1978).

■ *Install appropriate sediment control structures to trap suspended sediment transported by runoff and prevent its discharge into the aquatic environment.*

Methods to trap sediment include:

- **Brush Barriers.** Brush barriers are slash materials piled at the toe slope of a road or at the outlets of culverts, turnouts, dips, and water bars. Brush barriers should be installed at the toe of fills if the fills are located within 150 feet of a defined stream channel (Swift, 1988). Figure 3-20 shows the use of a brush barrier at the toe of fill. Proper installation is important because if the brush barrier is not firmly anchored and embedded in the slope, brush material may be ineffective for sediment removal and may detach to block ditches or culverts (Ontario Ministry of Natural Resources, 1988). In addition to use as brush barriers, slash can be spread over exposed mineral soils to reduce the impact of precipitation events and surface flow.
- **Silt Fences.** Silt fences are temporary barriers used to intercept sediment-laden runoff from small areas. They act as a strainer: silt and sand are trapped on the surface of the fence while water passes through.

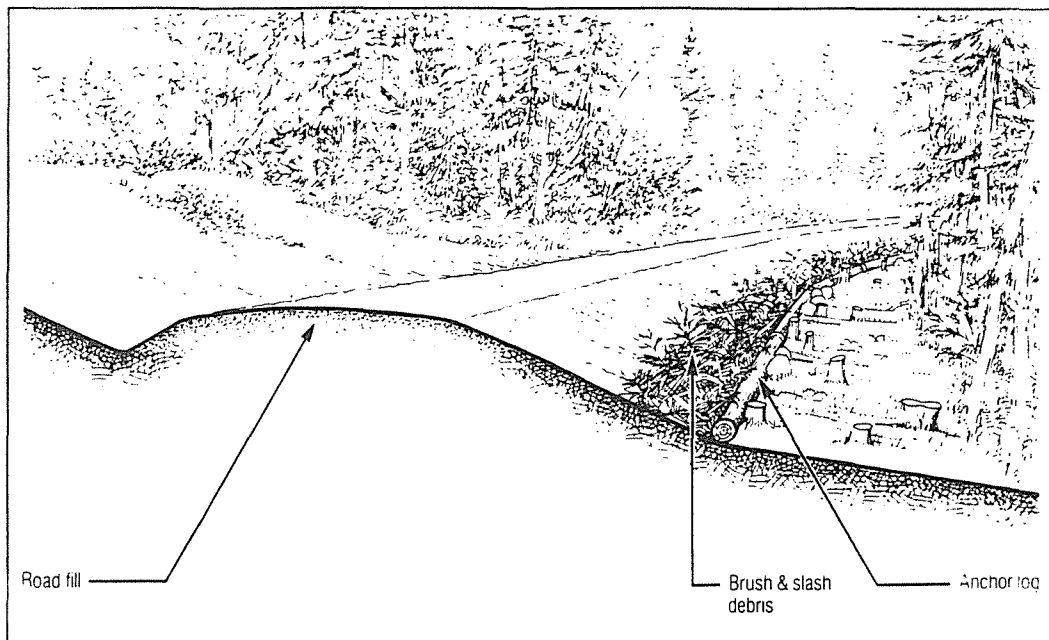

Figure 3-20. Brush barrier at toe of fill (Ontario Ministry of Natural Resources, 1988).

They may consist of woven geotextile filter fabric or straw bales. Silt fences should be installed prior to earthmoving operations and should be placed as close to the contour as possible.

- **Riprap.** Riprap is a layer of rocks or rock fragments placed over exposed soil to protect it from erosive forces. Riprap is generally used only in areas where the velocity of water flow, seriousness of erosion, steepness of slope, or material type prevents satisfactory establishment of vegetation. Stones of suitable size are fitted and implanted in the slope to form a contiguous cover (Figure 3-21). When used near streams, riprap should be extended below the stream channel scour depth and above the high water line. Commonly, a filter cloth or graded filter blanket of small gravel is laid beneath the riprap. Riprap should not be used on slopes that are naturally subject to deep-seated or avalanche-type slide failure. Riprap should be used in conjunction with other slope stabilization techniques and then only if these techniques are ineffective alone. Riprap is not recommended for very steep slopes or fine-grained soils (Hynson et al., 1982).
- **Filter Strips.** Sediment control is achieved by providing a filter or buffer strip between streams and construction activities in order to use the natural filtering capabilities of the forest floor and litter. The Streamside Management Area management measure requires the presence of a filter or buffer strip around all waterbodies.

■ *Revegetate or stabilize disturbed areas, especially at stream crossings.*

Cutbanks and fillslopes along forest roads are often difficult to revegetate (Berglund, 1978). Properly condition slopes to provide a seedbed, including rolling of embankments and scarifying of cut slopes. The rough soil surfaces will provide niches for seeds to lodge and germinate. Seed as soon as possible after disturbance, preferably during road construction or immediately following completion and within the same season (Larse, 1971). Early grassing and spreading of brush or erosion-resisting fabrics on exposed soils at stream crossings are imperative (Swift, 1985). See the Revegetation of Disturbed Areas management measure for a more detailed discussion.

■ *Protect access points to the site that lead from a paved public right-of-way with stone, wood chips, corduroy logs, wooden mats, or other material to prevent soil or mud from being tracked onto the paved road.*

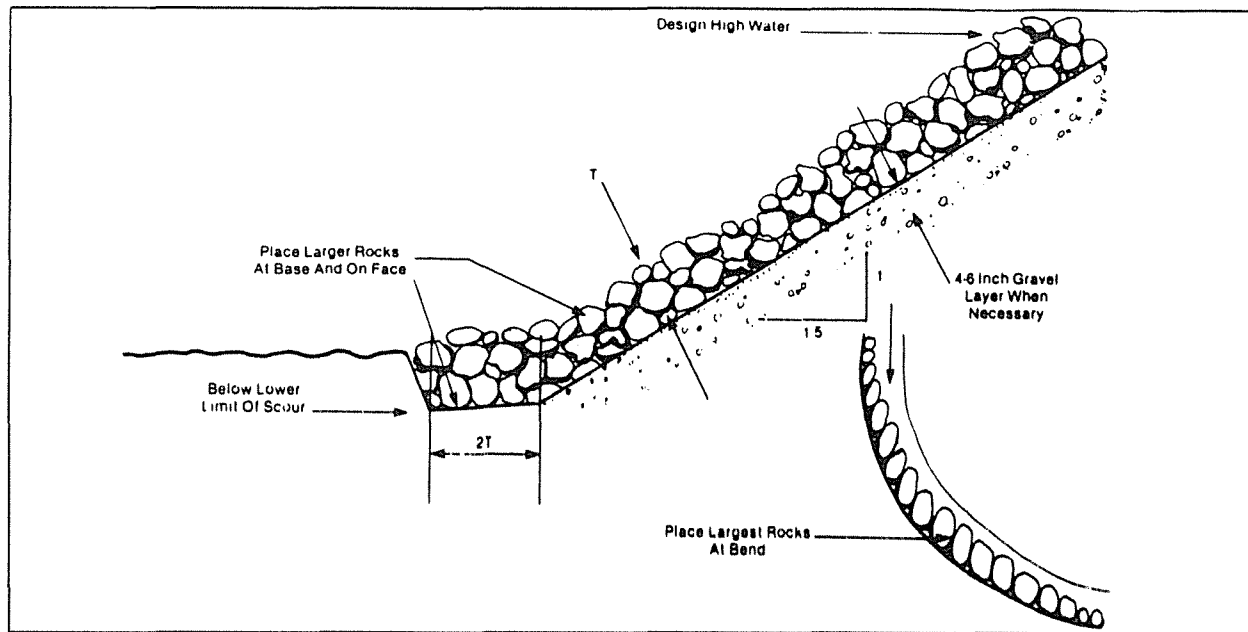

Figure 3-21. Dimensions of typical rock riprap blanket. T equals 1.5 times the diameter of the average size rock. When rock is spherical cobbles, or when machine-placed, $T=1.9D$ (Hynson et al., 1982).

This will prevent tracking of sediment onto roadways, thereby preventing the subsequent washoff of that sediment during storm events. When necessary, clean truck wheels to remove sediment prior to entering a public right-of-way.

■ **Construct stream crossings to minimize erosion and sedimentation.**

Avoid operating machinery in waterbodies. Work within or adjacent to live streams and water channels should not be attempted during periods of high streamflow, intense rainfall, or migratory fish spawning. Avoid channel changes and protect embankments with riprap, masonry headwalls, or other retaining structures (Larse, 1971).

If possible, culverts should be installed within the natural streambeds. The inlet should be on or below the streambed to minimize flooding upstream and to facilitate fish passage. Culverts should be firmly anchored and the earth compacted at least halfway up the side of the pipe to prevent water from leaking around it (Figure 3-22). Both ends of the culvert should protrude at least 1 foot beyond the fill (Hynson et al., 1982). Large culverts should be aligned with the natural course and gradient of the stream unless the inlet condition can be improved and the erosion potential reduced with some channel improvement (Larse, 1971). Use energy dissipators at the downstream end of the culverts to reduce the erosion energy of emerging water. Armor inlets to prevent undercutting and armor outlets to prevent erosion of fill or cut slopes.

■ **Excavation for a bridge or a large culvert should not be performed in flowing water. The water should be diverted around the work site during construction with a cofferdam or stream diversion.**

Isolating the work site from the flow of water is necessary to minimize the release of soil into the watercourse and to ensure a satisfactory installation in a dry environment. Limit the duration of construction to minimize environmental impacts by establishing disturbance limits, equipment limitations, the operational time period when disturbance can most easily be limited, and the use of erosion and sediment controls, such as silt fences and sediment catch basins. Diversions should be used only where constructing the stream crossing structure without diverting the stream would result in instream disturbance greater than the disturbance from diverting the stream. Figure 3-23 portrays a procedure for installing a large culvert when excavation in the channel of the stream would cause sedimentation and increase turbidity.

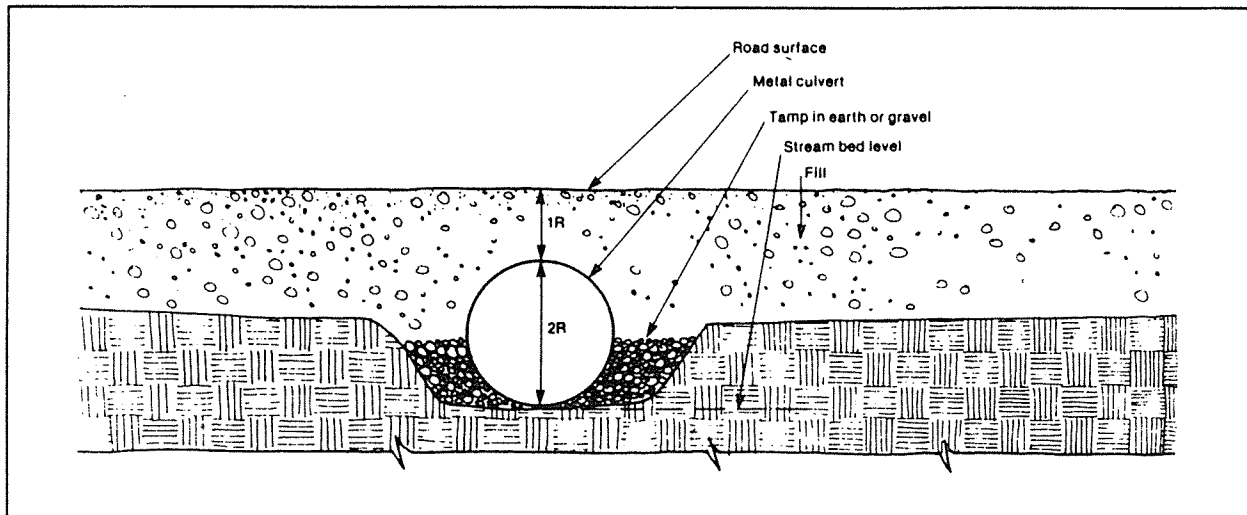

Figure 3-22. Culvert installation in streambed (Hynson et al., 1982).

■ *Compact the fill to minimize erosion and ensure road stability (Hynson et al., 1982).*

During construction, fills or embankments are built up by gradual layering. Compact the entire surface of each layer with a tractor or other construction equipment. If the road is to be grassed, the final layer should not be compacted in order to provide an acceptable seedbed.

■ *Properly dispose of organic debris generated during road construction (Hynson et al., 1982).*

- Stack usable materials such as timber, pulpwood, and firewood in suitable locations and use them to the extent possible. Alternatives for use of other materials include piling and burning, chipping, scattering, windrowing, and removal to designated sites.
- Organic debris should not be used as fill material for road construction since the organic material would eventually decompose and cause fill failure (Hynson et al., 1982; Larse, 1971).
- Debris that is accidentally deposited in streams during road construction should be removed before work is terminated.
- All work within the stream channel should be accomplished by hand to avoid the use of machinery in the stream and riparian zone (Hynson et al., 1982).

■ *Use pioneer roads to reduce the amount of area disturbed and ensure stability of the area involved.*

Pioneer roads are temporary access ways used to facilitate construction equipment access when building permanent roads.

- Confine pioneer roads to the construction limits of the surveyed permanent roadway.
- Fit the pioneer road with temporary drainage structures (Hynson et al., 1982).

■ *When soil moisture conditions are excessive, promptly suspend earthwork operations and take measures to weatherproof the partially completed work (Larse, 1971; Hynson et al., 1982).*

Regulating traffic on logging roads during unfavorable weather is an important phase of erosion control. Construction and logging under these conditions destroy drainage structures, plug up culverts, and cause excessive rutting, thereby increasing the amount and the cost of required maintenance (Kochenderfer, 1970).

■ Locate burn bays away from water and drainage courses.

■ If the use of borrow or gravel pits is needed during forest road construction, locate rock quarries, gravel pits, and borrow pits outside SMAs and above the 50-year flood level of any waters to minimize the adverse impacts caused by the resulting sedimentation. Excavation should not occur below the water table.

Gravel mining directly from streams causes a multitude of impacts including destruction of fish spawning sites, turbidity, and sedimentation (Hynson et al., 1982). During the construction and use of rock quarries, gravel pits, or borrow pits, runoff water should be diverted onto the forest floor or should be passed through one or more settling basins. Rock quarries, gravel pits, spoil disposal areas, and borrow pits should be revegetated and reclaimed upon abandonment.

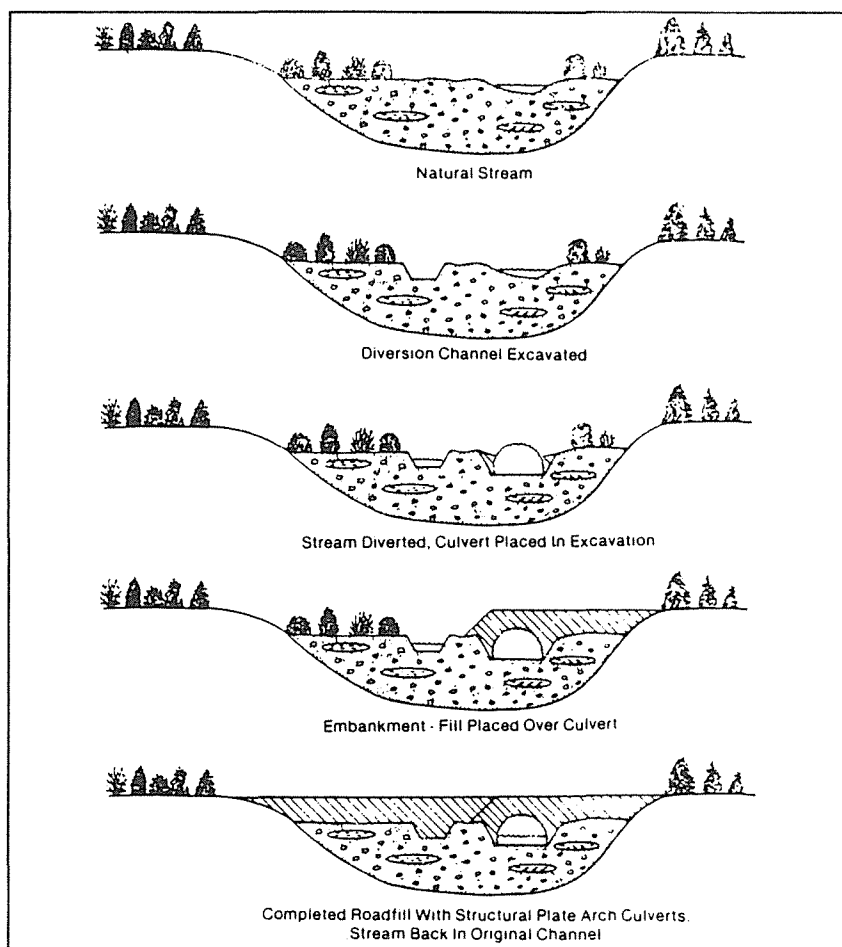

Figure 3-23. Culvert installation using a diversion (Hynson et al., 1982).

D. Road Management

- (1) Avoid using roads where possible for timber hauling or heavy traffic during wet or thaw periods on roads not designed and constructed for these conditions.
- (2) Evaluate the future need for a road and close roads that will not be needed. Leave closed roads and drainage channels in a stable condition to withstand storms.
- (3) Remove drainage crossings and culverts if there is a reasonable risk of plugging or failure from lack of maintenance.
- (4) Following completion of harvesting, close and stabilize temporary spur roads and seasonal roads to control and direct water away from the roadway. Remove all temporary stream crossings.
- (5) Inspect roads to determine the need for structural maintenance. Conduct maintenance practices, when conditions warrant, including cleaning and replacement of deteriorated structures and erosion controls, grading or seeding of road surfaces, and, in extreme cases, slope stabilization or removal of road fills where necessary to maintain structural integrity.
- (6) Conduct maintenance activities, such as dust abatement, so that chemical contaminants or pollutants are not introduced into surface waters to the extent practicable.
- (7) Properly maintain permanent stream crossings and associated fills and approaches to reduce the likelihood (a) that stream overflow will divert onto roads, and (b) that fill erosion will occur if the drainage structures become obstructed.

1. Applicability

This management measure pertains to lands where silvicultural or forestry operations are planned or conducted. It is intended to apply to active and inactive roads constructed or used for silvicultural activities.

Under the Coastal Zone Act Reauthorization Amendments of 1990, States are subject to a number of requirements as they develop coastal nonpoint source programs in conformity with this measure and will have some flexibility in doing so. The application of this management measure by States is described more fully in *Coastal Nonpoint Pollution Control Program: Program Development and Approval Guidance*, published jointly by the U.S. Environmental Protection Agency (EPA) and the National Oceanic and Atmospheric Administration (NOAA) of the U.S. Department of Commerce.

2. Description

The objective of this management measure is to manage existing roads to maintain stability and utility and to minimize sedimentation and pollution from runoff-transported materials. Roads that are actively eroding and providing significant sediment to waterbodies, whether in use or not, must be managed. If roads are no longer in use or needed in the foreseeable future, an effective treatment is to remove drainage crossings and culverts if there is a risk of plugging or failure from lack of maintenance. In other cases (e.g., roads in use), it may be more economically viable to periodically maintain crossing and drainage structures.

Sound planning, design, and construction measures often reduce the future levels of necessary road maintenance. Roads constructed with a minimum width in stable terrain, and with frequent grade reversals or dips, require minimum maintenance. However, older roads remain one of the greatest sources of sediment from forest land management. In some locations, problems associated with altered surface drainage and diversion of water from natural channels can result in serious gully erosion or landslides. After harvesting is complete, roads are often forgotten. Erosion problems may go unnoticed until after there is severe resource damage. In western Oregon, 41 out of the 104 landslides reported on private and State forest lands during the winter of 1989-90 were associated with older (built before 1984) forest roads. These landslides were related to both road drainage and original construction problems. Smaller erosion features, such as gullies and deep ruts, are far more common than landslides and very often are related to road drainage.

Drainage of the road prism, road fills in stream channels, and road fills on steep slopes are the elements of greatest concern in road management. Roads used for active timber hauling usually require the most maintenance, and mainline roads typically require more maintenance than spur roads. Use of roads during wet or thaw periods can result in a badly rutted surface, impaired drainage, and excessive sediment leading to waterbodies. Inactive roads, not being used for timber hauling, are often overlooked and receive little maintenance. Many forest roads that have been abandoned may be completely overgrown with vegetation, which makes maintenance very difficult.

Figure 3-24 illustrates some differences between a road with a well-maintained surface, good revegetation, and open drainage structures, and a poorly maintained road.

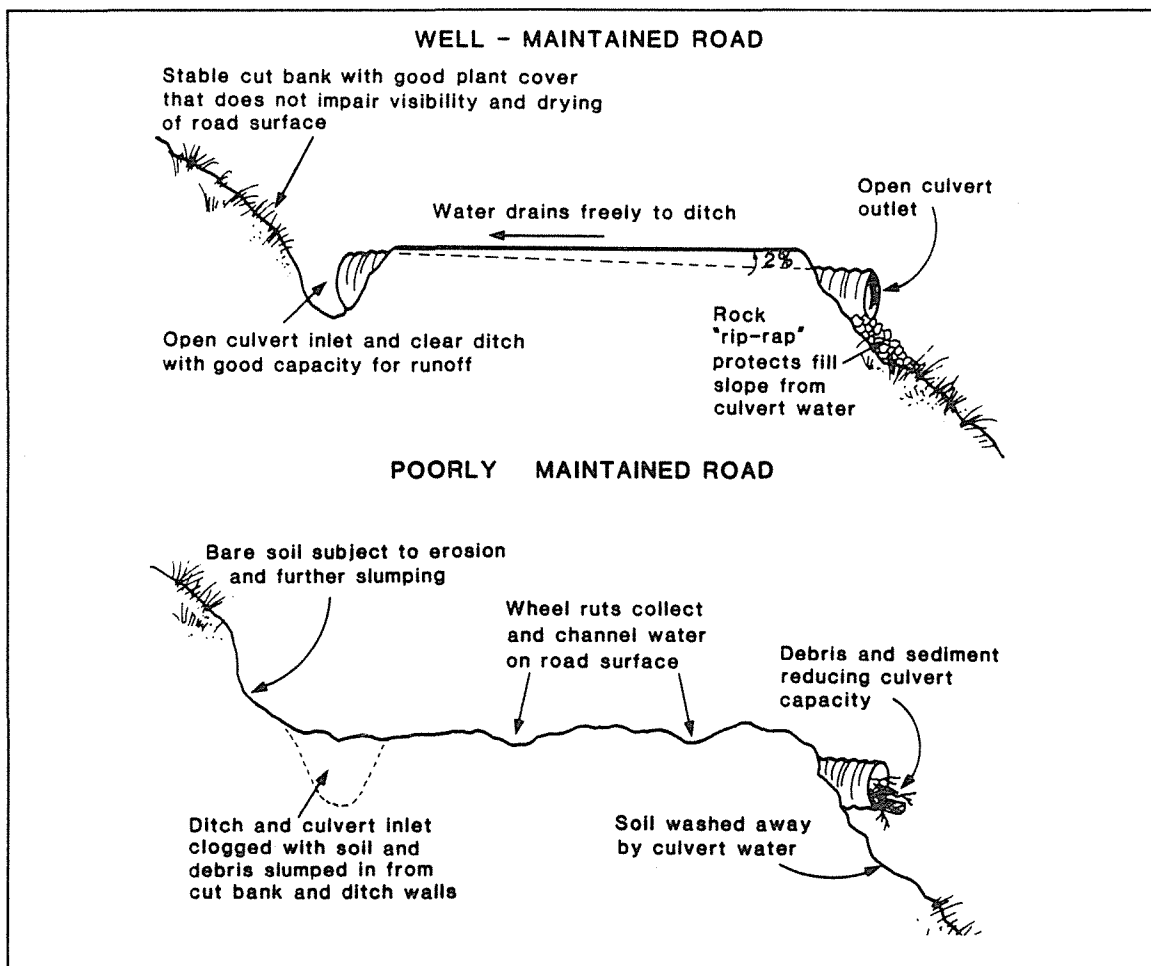

Figure 3-24. Road maintenance examples (Adams, 1991).

3. Management Measure Selection

a. Effectiveness Information

Drainage structures must be maintained to function properly. Culverts and ditches must be kept free of debris that can restrict water flow. Routine clearing can minimize clogging and prevent flooding, gullyng, and washout (Kochenderfer, 1970). Routine maintenance of road dips and surfaces and quick response to problems can significantly reduce road-caused slumps and slides and prevent the creation of berms that could channelize runoff (Oregon Department of Forestry 1981; Ontario Ministry of Natural Resources, 1988).

Proper road/trail closure is essential in preventing future erosion and sedimentation from abandoned roads and skid trails. Proper closure incorporates removal of temporary structures in watercourses, returning stream crossing approaches to their original grades, revegetating disturbed areas, and preventing future access (Kochenderfer, 1970; Rothwell, 1978). Revegetation of disturbed areas protects the soil from raindrop impact and aids soil aggregation, and therefore reduces erosion and sedimentation (Rothwell, 1978).

b. Cost Information

Benefits of proper road maintenance were effectively shown by Dissmeyer and Frandsen (1988). Maintenance costs for road repair were 44 percent greater without implementation of control measures than for installation of BMPs (Table 3-31).

Dissmeyer and Foster (1987) presented an analysis of the economic benefits of various watershed treatments associated with roads (Table 3-32). Specifically, they examined the cost of revegetating cut-and-fill slopes and the costs of various planning and management technical services (e.g., preparing soil and water prescriptions, compiling soils data, and reviewing the project in the field). These costs were compared to savings in construction and maintenance costs resulting from the watershed treatments. Specifically, savings were realized from avoiding problem soils, wet areas, and unstable slopes. The economic analysis showed that the inclusion of soil and water resource management (i.e., revegetating and technical services) in the location and construction of forest roads resulted in an estimated savings of \$311 per kilometer in construction costs and \$186 per kilometer in maintenance costs.

As part of the Fisher Creek Watershed Improvement Project, Rygh (1990) examined the various costs of ripping and scarification using different techniques. The major crux of Rygh's work was to compare the relative advantages of using a track hoe for ripping and scarification versus the use of large tractor-mounted rippers. He found track hoes to be preferable to tractor-mounted rippers for a variety of reasons, including the following:

- A reduction in furrows and resulting concentrated runoff caused by tractors;
- Improved control over the extent of scarification;
- Increased versatility and maneuverability of track hoes; and
- Cost savings.

Rygh estimated that the cost of ripping with a track hoe ranged from \$220 to \$406 per mile compared to a cost of \$550 per mile for ripping with a D7 or D8 tractor (Table 3-33).

4. Practices

As discussed more fully at the beginning of this chapter and in Chapter 1, the following practices are described for illustrative purposes only. State programs need not require implementation of these practices. However, as a practical matter, EPA anticipates that the management measure set forth above generally will be implemented by applying one or more management practices appropriate to the source, location, and climate. The practices set forth below have been found by EPA to be representative of the types of practices that can be applied successfully to achieve the management measure described above.

Table 3-31. Comparison of Road Repair Costs for a 20-Year Period With and Without BMPs^a (Dissmeyer and Frandsen, 1988)

Maintenance Costs Without BMPs		Costs of BMP Installation	
Equipment	\$365	Labor to construct terraces and water diversions	\$ 780
Materials (gravel)	122	Materials to revegetate	120
Work supervision	40	Cost of technical assistance	300
Repair cost per 3 years	527	Total cost over 20 years	\$1,200
Total cost over 20 years ^b	\$2,137		

IRR: 11.2%

PNV: \$937

B/C ratio: 1.78 to 1.00 for road BMP installation versus reconstruction/repair.

^a BMPs include construction of terraces and water diversions, and seeding.

^b Discounted @ 4%.

Table 3-32. Analysis of Costs and Benefits of Watershed Treatments Associated with Roads (SE U.S.) (Dissmeyer and Foster, 1987)

	Treatment ^a		
	Seed Without Mulch	Seed With Mulch	Hydroseed With Mulch
<u>Costs</u>			
Cost per kilometer (\$)	356	569	701
Cost per kilometer for soil and water technical services (\$)	62	62	62
Total cost of watershed treatment (\$)	418	631	763
<u>Benefits^b</u>			
Savings in construction costs (\$/km)	311	311	311
Savings in annual maintenance costs (\$/km)	186	186	186
Benefit/cost (10-year period)	4.4:1	2.9:1	2.4:1

Adapted from West, S., and B.R. Thomas, 1982. Effects of Skid Roads on Diameter, Height, and Volume Growth in Douglas-Fir. *Soil Sci. Soc. Am. J.*, 45:629-632.

^a Treatments included fertilization and liming where needed.

^b Cost savings were associated with soil and water resource management in the location and construction of forest roads by avoiding problem soils, wet areas, and unstable slopes. Maintenance cost savings were derived from revegetating cut and fill slopes, which reduced erosion, prolonging the time taken to fill ditch lines with sediment and reducing the frequency of ditch line reconstruction.

■ *Blade and reshape the road to conserve existing surface material; to retain the original, crowned, self-draining cross section; and to prevent or remove berms (except those designed for slope protection) and other irregularities that retard normal surface runoff (Larse, 1971).*

Ruts and potholes can weaken road subgrade materials by channeling runoff and allowing standing water to persist (Rothwell, 1978). Periodic grading of the road surface is necessary to fill in wheel ruts and to reshape the road (Hausman and Pruett, 1978). Maintenance practices must be modified for roads with broad-based dips (Swift, 1985). Maintenance by a motor grader is difficult because scraping tends to fill in the dips, the blade cannot be

Table 3-33. Comparative Costs of Reclamation of Roads and Removal of Stream Crossing Structures (ID) (Rygh, 1990)

Method	Cost (dollar/mile)
Ripping/scarification	
Ripping with D7 or D8 tractor	\$550
Scarifying with D8-mounted brush blade	\$844
Scarification to 6-inch depth and installation of water bars with track hoe	\$1,673
Ripping and slash scattering with track hoe	\$440 - \$660
Ripping, slash scattering, and water bar installation with track hoe	\$812
Ripping with track hoe	\$220 - \$406

maneuvered to clean the dip outlet, and cut banks are destabilized when the blade undercuts the toe of the slope. Small bulldozers or front-end loaders appear to be more suitable for periodic maintenance of intermittent-use forest roads (Swift, 1988).

■ *Clear road inlet and outlet ditches, catch basins, culverts, and road-crossing structures of obstructions (Larse, 1971).*

Avoid undercutting backslopes when cleaning silt and debris from roadside ditches (Rothwell, 1978). Minimize machine cleaning of ditches during wet weather. Do not disturb vegetation when removing debris or slide blockage from ditches (Larse, 1971; Rothwell, 1978). The outlet edges of broad-based dips need to be cleaned of trapped sediment to eliminate mudholes and prevent the bypass of stormwaters. The frequency of cleaning depends on traffic load (Swift, 1988). Clear stream-crossing structures and their inlets of debris, slides, rocks, and other materials prior to and following any heavy runoff period (Hynson et al., 1982).

■ *Maintain road surfaces by mowing, patching, or resurfacing as necessary.*

Grassed roadbeds carrying fewer than 20-30 vehicle trips per month usually require only annual roadbed mowing and periodic trimming of encroaching vegetation (Swift, 1988).

■ *Remove temporary stream crossings to maintain adequate streamflow (Hynson et al., 1982).*

Failure or plugging of abandoned temporary crossing structures can result in greatly increased sedimentation and turbidity in the stream, and channel blowout.

■ *Wherever possible, completely close the road to travel and restrict access by unauthorized persons by using gates or other barriers (Hausman and Pruett, 1978).*

Where such restrictions are not feasible, traffic should be regulated (Rothwell, 1978).

■ *Install or regrade water bars on roads that will be closed to vehicle traffic and that lack an adequate system of broad-based dips (Kochenderfer, 1970).*

Water bars will help to minimize the volume of water flowing over exposed areas and remove water to areas where it will not cause erosion. Water bar spacing depends on soil type and slope. Table 3-34 contains suggested guidelines for water bar spacing. Water should flow off the water bar onto rocks, slash, vegetation, duff, or other less erodible material and should never be diverted directly to streams or bare areas (Oregon Department of Forestry, 1979a). Outslope closed road surfaces to disperse runoff and prevent closed roads from routing water to streams.

■ *Revegetate to provide erosion control and stabilize the road surface and banks.*

Refer to Revegetation of Disturbed Areas management measure for a more detailed discussion.

■ *Replace open-top culverts with cross drains (water bars, dips, or ditches) to control and divert runoff from road surfaces (Rothwell, 1978; Hausman and Pruett, 1978).*

Open-top culverts are for temporary drainage of ongoing operations. It is important to replace them with more permanent drainage structures to ensure adequate drainage and reduce erosion potential prior to establishment of vegetation on the roadbed.

■ *Periodically inspect closed roads to ensure that vegetational stabilization measures are operating as planned and that drainage structures are operational (Hynson et al., 1982; Rothwell, 1978). Conduct reseeding and drainage structure maintenance as needed.*

**Table 3-34. Water Bar Spacing by Soil Type and Slope
(Oregon Department of Forestry, 1979a)**

Road Grade (percent)	Soil Type		
	Granitic or Sandy	Shale or Gravel	Clay
2	900	1000	1000
4	600	1000	800
6	500	1000	600
8	400	900	500
10	300	800	400
12	200	700	400
15	150	500	300
20	150	300	200
25+	100	200	150

Note: Distances are approximate and should be varied to take advantage of natural features.

E. Timber Harvesting

The timber harvesting management measure consists of implementing the following:

- (1) Timber harvesting operations with skid trails or cable yarding follow layouts determined under Management Measure A.
- (2) Install landing drainage structures to avoid sedimentation to the extent practicable. Disperse landing drainage over sideslopes.
- (3) Construct landings away from steep slopes and reduce the likelihood of fill slope failures. Protect landing surfaces used during wet periods. Locate landings outside of SMAs.
- (4) Protect stream channels and significant ephemeral drainages from logging debris and slash material.
- (5) Use appropriate areas for petroleum storage, draining, dispensing. Establish procedures to contain and treat spills. Recycle or properly dispose of all waste materials.

For cable yarding:

- (1) Limit yarding corridor gouge or soil plowing by properly locating cable yarding landings.
- (2) Locate corridors for SMAs following Management Measure B.

For groundskidding:

- (1) Within SMAs, operate groundskidding equipment only at stream crossings to the extent practicable. In SMAs, fell and endline trees to avoid sedimentation.
- (2) Use improved stream crossings for skid trails which cross flowing drainages. Construct skid trails to disperse runoff and with adequate drainage structures.
- (3) On steep slopes, use cable systems rather than groundskidding where groundskidding may cause excessive sedimentation.

1. Applicability

This management measure pertains to lands where silvicultural or forestry operations are planned or conducted. It is intended to apply to all harvesting, yarding, and hauling conducted as part of normal silvicultural activities on harvest units larger than 5 acres. This measure does not apply to harvesting conducted for precommercial thinnings or noncommercial firewood cutting.

Under the Coastal Zone Act Reauthorization Amendments of 1990, States are subject to a number of requirements as they develop coastal nonpoint source programs in conformity with this measure and will have some flexibility in doing so. The application of this management measure by States is described more fully in *Coastal Nonpoint Pollution Control Program: Program Development and Approval Guidance*, published jointly by the U.S. Environmental Protection Agency (EPA) and the National Oceanic and Atmospheric Administration (NOAA) of the U.S. Department of Commerce.

2. Description

The goal of this management measure is to minimize sedimentation resulting from the siting and operation of timber harvesting, and to manage petroleum products properly.

Logging practices that protect water quality and soil productivity can also reduce total mileage of roads and skid trails, lower equipment maintenance costs, and provide better road protection and lower road maintenance. Careful logging can disturb soil surfaces as little as 8 percent, while careless logging practices can disturb soils as much as 40 percent (Golden et al., 1984). In the Appalachians, skid roads perpendicular to the contour, instead of along the contour, yielded 40 tons of sediment per acre of skid road surface (Hornbeck and Reinhart, 1964). Higher bulk densities and lower porosity of skid road soils due to compaction by rubber-tired skidders result in reduced soil infiltration capacity and corresponding increases in runoff and erosion (Dickerson, 1975). Douglass and Swank (1975) found that poor logging techniques increased sediment production during storms by 10 to 20 times more than sediment production from the undisturbed control watershed. A properly logged watershed experienced only slightly increased sedimentation compared to the undisturbed control watershed.

Locating landings for both groundskidding and cable yarding harvesting systems according to preharvest planning minimizes erosion and sediment delivery to surface waters. However, final siting of landings may need to be adjusted in the field based on site characteristics.

Landings and loading decks can become very compacted and puddled and are therefore a source of runoff and erosion (Golden et al., 1984). Practices that prevent or disperse runoff from these areas before the runoff reaches watercourses will minimize sediment delivery to surface waters. Also, any chemicals or petroleum products spilled in harvest areas can be highly mobile, adversely affecting the water quality of nearby surface waters. Correct spill prevention and containment procedures are therefore necessary to prevent petroleum products from entering surface waters. Designation of appropriate areas for petroleum storage will also minimize water quality impacts due to spills or leakage.

3. Management Measure Selection

This management measure is based on the experience and information gained from studies and from States using similar harvesting practices. Many studies have evaluated and compared the effects of different timber harvest techniques on sediment loss (erosion), soil compaction, and overall ground disturbance associated with various harvesting techniques. The data presented in Tables 3-35 through 3-40 were compiled from many different studies conducted throughout the United States and Canada. Many local factors such as climatic conditions, soil type, and topography affected the results of each study. The studies also examined harvesting techniques under a variety of conditions, including clearcuts, selective cuts, and fire-salvaged areas. However, the major conclusions from the studies on the relative impacts of different timber harvesting techniques on soil erosion and the causes and consequences of ground disturbance remain fairly constant between the studies and enable cross-geographic comparison.

Some of the most significant water quality impacts from logging operations (especially increased sedimentation) result from the actual yarding operations and activities on landings. The critical factors that affect the degree of soil disturbance associated with a particular yarding technique include the amount of disturbance caused by the yarding machinery itself and the amount of road construction needed to support each system. Stone (1973) presented information suggesting that roads may contribute greater than 90 percent of the sedimentation problems associated with logging operations. Therefore, since road areas represent potential erosion sites, it is important to recognize and consider the amount of land used for roads by various logging systems (Sidle, 1980).

a. Effectiveness Information

The amount of total soil disturbance varies considerably between the different yarding techniques. Megahan (1980) presented the most comprehensive survey of the available information on these impacts, presenting the data in two

ways: soil disturbance associated with the actual yarding operation and soil disturbance associated with the construction of roads needed for the practice (Tables 3-35 and 3-36). The results of his investigation echoed other studies presented in this section and clearly show that aerial and skyline cable techniques are far less damaging than other yarding techniques.

The amount of soil disturbance by yarding depends on the slope of the area, volume yarded, size of logs, and the logging system. Table 3-36 presents data on the extent of soil disturbance associated with particular yarding systems. Megahan's ranking of yarding techniques (from greatest impact to lowest impact) based on percent area disturbed is summarized as follows: tractor (21 percent average), ground cable (21 percent, one study), high-lead (16 percent

Table 3-35. Soil Disturbance from Roads for Alternative Methods of Timber Harvesting (Megahan, 1980)

Logging System (State)	Percent of Logged Area Bared			Reference
	Roads	Skid Roads and Landings	Total	
Tractor:				
Tractor — clearcut (BC)	30.0	—	30.0	Smith, 1979
Tractor — selection (CA)	2.7	5.7	8.4	Rice, 1961
Tractor — selection (ID)	2.2	6.8	9.0	Haupt and Kidd, 1965
Tractor — group selection (ID)	1.0	6.7	7.7	Haupt and Kidd, 1965
Tractor and helicopter — fire salvage (WA)	4.5	0.4	4.9	Klock, 1975
Tractor and cable — fire salvage (WA)	16.9	—	16.9	Klock, 1975
Ground Cable:				
Jammer — group selection (ID)	25-30	—	25-30	Megahan and Kidd, 1972
Jammer — clearcut (BC)	8.0	—	8.0	Smith, 1979
High-lead — clearcut (BC)	14.0	—	14.0	Smith, 1979
High-lead — clearcut (OR)	6.2	3.6	9.8	Silen and Gratkowski, 1953
High-lead — clearcut (OR)	3.0	1.0	4.0	Brown and Krygier, 1971
High-lead — clearcut (OR)	6.0	1.0	7.0	Brown and Krygier, 1971
High-lead — clearcut (OR)	6.0	—	6.0	Fredriksen, 1970
Skyline:				
Skyline — clearcut (OR)	2.0	—	2.0	Binkley, 1965
Skyline — clearcut (BC)	1.0	—	1.0	Smith, 1979
Aerial:				
Helicopter — clearcut	1.2	—	1.2	Binkley ^a

^a Estimated by Virgil W. Binkley, Pacific Northwest Region, USDA Forest Service, Portland, OR.

Table 3-36. Soil Disturbance from Logging by Alternative Harvesting Methods (Megahan, 1980)

Method of Harvest	Location	Disturbance (%)	Reference
Tractor:			
Tractor — clearcut	E. WA	29.4	Wooldridge, 1960
Tractor — clearcut	W. WA	26.1	Steinbrenner and Gessel, 1955
Tractor — fire salvage	E. WA	36.2	Klock ^a , 1975
Tractor on snow — fire salvage	E. WA	9.9	Klock ^a , 1975
Tractor — clearcut	BC	7.0	Smith, 1979
Tractor — selection	E. WA, OR	15.5	Garrison and Rummel, 1951
Ground Cable:			
Cable - selection	E. WA, OR	20.9	Garrison and Rummel, 1951
High-lead — fire salvage	E. WA	32.0	Klock ^a , 1975
High-lead — clearcut	W. OR	14.1	Dyrness, 1965
High-lead — clearcut	W. OR	12.1	Ruth, 1967
High-lead — clearcut	BC	6.0	Smith, 1979
Jammer — clearcut	BC	5.0	Smith, 1979
Grapple — clearcut	BC	1.0	Smith, 1979
Skyline:			
Skyline — clearcut	W. OR	12.1	Dyrness, 1965
Skyline — clearcut	E. WA	11.1	Wooldridge, 1960
Skyline — clearcut	BC	7.0	Smith, 1979
Skyline — clearcut	W. OR	6.4	Ruth, 1967
Skyline — fire salvage	E. WA	2.8	Klock ^a , 1975
Balloon — clearcut	W. OR	6.0	Dyrness ^b
Aerial:			
Helicopter — fire salvage	E. WA	0.7	Klock ^a , 1975
Helicopter — clearcut	ID	5.0	Clayton (in press)

^a Disturbance shown is classified as severe.

^b Dyrness, C.T., unpublished data on file, Pacific Northwest Forest and Range Experiment Station, Corvallis, OR.

average), skyline (8 percent average), jammer in clearcut (5 percent, one study), and aerial techniques (4 percent average).

The amount of road required for different yarding techniques varies considerably. Sidle (1980) defined the amount of land used for haul roads by various logging methods. Skyline techniques require the least amount of road area, with only 2-3.5 percent of the land area in roads. Tractor and single-drum jammer techniques require the greatest amount of road area (10-15 and 18-24 percent of total area, respectively). High-lead cable techniques fall in the

middle, with 6-10 percent of the land used for roads. Megahan (1980) concluded that tractor, jammer, and high-lead cable methods result in significantly higher amounts of disturbed soil than do the skyline and aerial techniques.

Sidle (1980) also presented data showing that tractors cause the greatest amount of soil disturbance (35 percent of land area) and soil compaction (26 percent of land area). Sidle (1980) concluded that skyline and aerial balloon techniques created the least disturbance (12 and 6 percent, respectively) and compaction (3 and 2 percent, respectively) (Table 3-37).

Miller and Sirois (1986) compared the land area disturbed by cable, skyline, and groundskidding systems (Table 3-38). They found groundskidding operations to affect 31 percent of the total land area, whereas cable yarding only affected 16 percent of the total land area. Similarly, Patric (1980) found skidders to serve the smallest area per mile of road (20 acres), with skyline yarding serving the largest area per mile of road (80 acres) (Table 3-39).

Table 3-37. Relative Impacts of Four Yarding Methods on Soil Disturbance and Compaction in Pacific Northwest Clearcuts (OR, WA, ID) (Sidle, 1980)

Yarding Method	Bare Soil (%)	Compacted Soil (%)
Tractor	35	26
High-lead	15	9
Skyline	12	3
Balloon	6	2

Table 3-38. Percent of Land Area Affected by Logging Operations (Southwest MS) (Miller and Sirois, 1986)

Operational Area	Cable Skyline	Groundskidding
Landings	4.1	6.4
Spur roads	2.6	3.5
Cable corridors or skid trails	<u>9.2</u>	<u>21.4</u>
Total	15.9	31.3

Table 3-39. Skidding/Yarding Method Comparison (Patric, 1980)^a

Harvesting System	Acres Served per Mile of Road
Wheeled skidder	20
Jammer	31
High-lead	40
Skyline	80

^a Adapted from Kochenderfer and Wendel (1978) and unpublished work by Thorsen.

b. Cost Information

The costs and benefits of rehabilitation of skid trails by planting hardwood, hardwood pine, and shortleaf pine in the southeastern United States were studied by Dissmeyer and Foster (1986). The average rehabilitation cost per acre was \$360 and included water barring, ripping or disking, seeding, fertilizing, and mulching where needed (Table 3-40). The benefit/cost ratio of the rehabilitation cost was \$1.33 for hardwood, \$2.82 for hardwood pine, and \$5.07 for shortleaf pine. The real rate of return over inflation ranged from 2.4 to 4.8 percent.

4. Practices

As discussed more fully at the beginning of this chapter and in Chapter 1, the following practices are described for illustrative purposes only. State programs need not require implementation of these practices. However, as a

Table 3-40. Analysis of Costs and Benefits of Skid Trail Rehabilitation in the Management of Three Southern Timber Types in the Southeast (Dissmeyer and Foster, 1986)

	Units	Timber Type		
		Hardwood	Hardwood Pine	Shortleaf Pine
Rotation	Years	70	60	60
Harvest volume per hectare	m ³	301	350	420
Value per cubic meter	\$ ^b	28.57	42.86	64.29
Total value of timber per hectare for uncompacted soil	\$ ^b	8,600	15,001	27,002
Timber volume per acre on skid trails (26% of uncompacted soil)	m ³	78	91	109
Timber volume lost per acre	m ³	223	259	311
Cost per hectare for skid trail rehabilitation ^a	\$ ^b	900	900	900
Timber volume recovered (75% of loss)	m ³	167	194	233
Value of timber volume recovered	\$ ^b	4,771	8,315	14,980
Internal rate of return based upon timber volume recovered	% ^c	2.4	3.8	4.8
Net present value of timber volume recovered (@ 2%)	\$ ^b	1,193	2,538	4,568
B/C ratio of rehab. cost	Ratio	1.33:1	2.82:1	5.07:1

Note: Skid trail rehabilitation reduces sediment yields.

m³: cubic meters.

^a Average cost for skid trail rehabilitation includes water barring, ripping or disking, seeding, fertilizing, and mulching where needed (\$900/ha = \$360/ac).

^b 1986 dollars.

^c Percentage points over inflation.

practical matter, EPA anticipates that the management measure set forth above generally will be implemented by applying one or more management practices appropriate to the source, location, and climate. The practices set forth below have been found by EPA to be representative of the types of practices that can be applied successfully to achieve the management measure described above.

a. Harvesting Practices

- *Fell trees away from watercourses, whenever possible, keeping logging debris from the channel, except where debris placement is specifically prescribed for fish or wildlife habitat (Megahan, 1983).*
- *Any tree accidentally felled in a waterway should be immediately removed (Huff and Deal, 1982).*
- *Remove slash from the waterbody and place it out of the SMA.*

This will allow unrestricted water flow and protection of the stream's nutrient balance. Remove only logging-generated debris. Leave pieces of large woody debris in place during stream cleaning to preserve channel integrity and maintain stream productivity. Bilby (1984) concluded that indiscriminate removal of large woody debris can adversely affect channel stability. Table 3-41 presents a possible way to determine debris stability.

b. Practices for Landings

- *Landings should be no larger than necessary to safely and efficiently store logs and load trucks.*
- *Install drainage and erosion control structures as necessary.*

Diversion ditches placed around the uphill side of landings minimize accumulation of water on the landing. Landings should have a slight slope to facilitate drainage. Also, adequate drainage on approach roads will prevent road drainage water from entering the landing area.

- *The slope of the landing surface should not exceed 5 percent and should be shaped to promote efficient drainage.*

Table 3-41. General Large Woody Debris Stability Guide Based on Salmon Creek, Washington (Bilby, 1984)

-
- 1.a. If debris is anchored or buried in the streambed or bank at one or both ends or along the upstream face - LEAVE.
 - 1.b. If debris is not anchored, go to 2.
 - 2.a. If debris is longer than 10.0 m - LEAVE.
 - 2.b. If debris is shorter than 10.0 m - go to 3.
 - 3.a. If debris is greater than 50 cm in diameter - go to 4.
 - 3.b. If debris is less than 50 cm in diameter - go to 5.
 - 4.a. If debris is longer than 5.0 m - LEAVE.
 - 4.b. If debris is shorter than 5.0 m - go to 5.
 - 5.a. If debris is braced on the downstream side by boulders, bedrock outcrops, or stable pieces of debris - LEAVE.
 - 5.a. If debris is not braced on the downstream side - REMOVE.
-

- *The slope of landing fills should not exceed 40 percent, and woody or organic debris should not be incorporated into fills.*
- *If landings are to be used during wet periods, protect the surface with a suitable material such as wooden matting or gravel surfacing.*
- *Install drainage structures for the landings such as water bars, culverts, and ditches to avoid sedimentation. Disperse landing drainage over sideslopes. Provide filtration or settling if water is concentrated in a ditch.*
- *Upon completion of harvest, clean up landing, regrade, and revegetate (Rothwell, 1978).*
 - Upon abandonment, minimize erosion on landings by adequately ditching or mulching with forest litter.
 - Establish a herbaceous cover on areas that will be used again in repeated cutting cycles, and restock landings that will not be reused (Megahan, 1983).
 - If necessary, install water bars for drainage control.
- *Locate landings for cable yarding where slope profiles provide favorable deflection conditions so that the yarding equipment used does not cause yarding corridor gouge or soil plowing, which concentrates drainage or causes slope instability.*
- *Locate cable yarding corridors for streamside management areas following Management Measure B components. Yarded logs should not cause disturbance of the major channel banks of the watercourse of the SMA.*

c. Groundskidding Practices

- *Skid uphill to log landings whenever possible. Skid with ends of logs raised to reduce rutting and gouging.*

This practice will disperse water on skid trails away from the landing. Skidding uphill lets water from trails flow onto progressively less-disturbed areas as it moves downslope, reducing erosion hazard. Skidding downhill concentrates surface runoff on lower slopes along skid trails, resulting in significant erosion and sedimentation hazard (Figure 3-25). If skidding downhill, provide adequate drainage on approach trails so that drainage does not enter landing.

- *Skid perpendicular to the slope (along the contour), and avoid skidding on slopes greater than 40 percent.*

Following the contour will reduce soil erosion and encourage revegetation. If skidding must be done parallel to the slope, then skid uphill, taking care to break the grade periodically.

- *Avoid skid trail layouts that concentrate runoff into draws, ephemeral drainages, or watercourses. Use endlining to winch logs out of SMAs or directionally fell trees so tops extend out of SMAs and trees can be skidded without operating equipment in SMAs. In SMAs, trees should be carefully endlined to avoid soil plowing or gouge.*

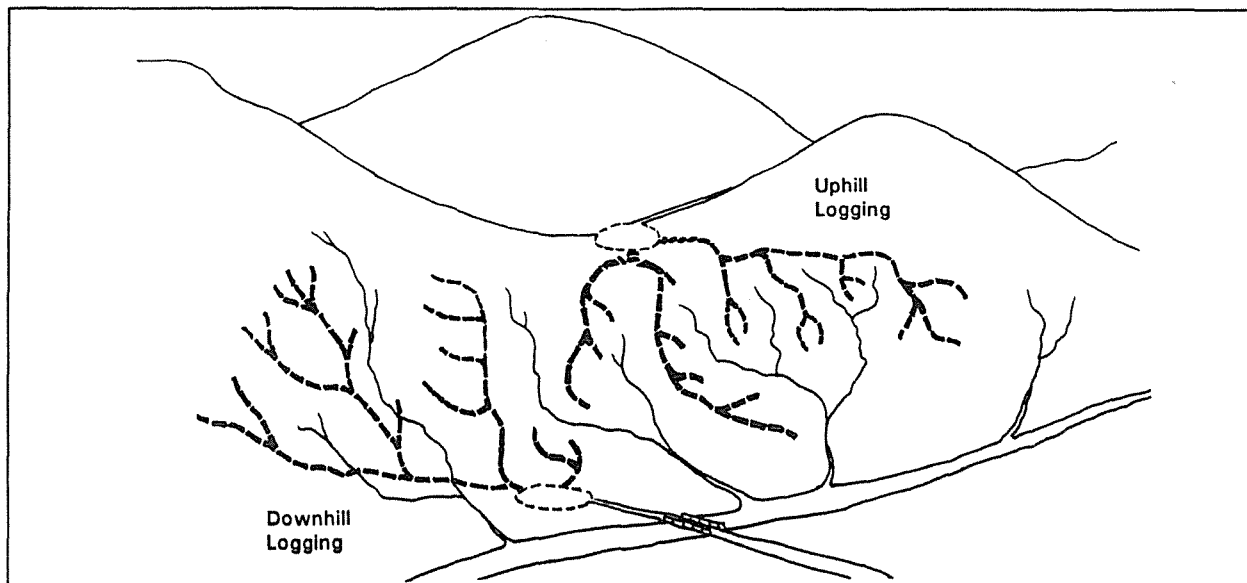

Figure 3-25. Hypothetical skid trail pattern for uphill and downhill logging (Megahan, 1983).

■ *Suspend groundskidding during wet periods, when excessive rutting and churning of the soil begins, or when runoff from skid trails is turbid and no longer infiltrates within a short distance from the skid trail. Further limitation of groundskidding of logs, or use of cable yarding, may be needed on slopes where there are sensitive soils and/or during wet periods.*

■ *Retire skid trails by installing water bars or other erosion control and drainage devices, removing culverts, and revegetating (Rothwell, 1978; Lynch et al, 1985).*

- After logging, obliterate and stabilize all skid trails by mulching and reseeding.
- Build cross drains on abandoned skid trails to protect stream channels or side slopes in addition to mulching and seeding.
- Restore stream channels by removing temporary skid trail crossings (Megahan, 1983).
- Scatter logging slash to supplement water bars and seeding to reduce erosion on skid trails (Lynch et al., 1985).

d. Cable Yarding Practices

■ *Use cabling systems or other systems when groundskidding would expose excess mineral soil and induce erosion and sedimentation.*

- Use high-lead cable or skyline cable systems on slopes greater than 40 percent.
- To avoid soil disturbance from sidewash, use high-lead cable yarding on average-profile slopes of less than 15 percent.

■ *Avoid cable yarding in or across watercourses.*

When cable yarding across streams cannot be avoided, use full suspension to minimize damage to channel banks and vegetation in the SMA.

■ *Yard logs uphill rather than downhill.*

In uphill yarding, log decks are placed on ridge or hill tops rather than in low-lying areas (Megahan, 1983). This creates less soil disturbance because the lift imparted to the logs reduces frictional resistance and the outward radiation of yard trails downhill from the landing disperses runoff evenly over the slope and reduces erosion potential. Downhill yarding should be avoided because it concentrates surface erosion.

e. Petroleum Management Practices

■ *Service equipment where spilled fuel and oil cannot reach watercourses, and drain all petroleum products and radiator water into containers. Dispose of wastes and containers in accordance with proper waste disposal procedures.¹ Waste oil, filters, grease cartridges, and other petroleum-contaminated materials should not be left as refuse in the forest.*

■ *Take precautions to prevent leakage and spills. Fuel trucks and pickup-mounted fuel tanks must not have leaks.*

- Use and maintain seepage pits or other confinement measures to prevent diesel oil, fuel oil, or other liquids from running into streams or important aquifers.
- Use drip collectors on oil-transporting vehicles (Hynson et al., 1982).

■ *Develop a spill contingency plan that provides for immediate spill containment and cleanup, and notification of proper authorities.*

- Provide materials for adsorbing spills, and collect wastes for proper disposal.

¹ The Resource Conservation and Recovery Act (RCRA) regulates the transportation, handling, storage, and disposal of hazardous materials, including petroleum products and by-products.

F. Site Preparation and Forest Regeneration

Confine on-site potential NPS pollution and erosion resulting from site preparation and the regeneration of forest stands. The components of the management measure for site preparation and regeneration are:

- (1) Select a method of site preparation and regeneration suitable for the site conditions.
- (2) Conduct mechanical tree planting and ground-disturbing site preparation activities on the contour of sloping terrain.
- (3) Do not conduct mechanical site preparation and mechanical tree planting in streamside management areas.
- (4) Protect surface waters from logging debris and slash material.
- (5) Suspend operations during wet periods if equipment used begins to cause excessive soil disturbance that will increase erosion.
- (6) Locate windrows at a safe distance from drainages and SMAs to control movement of the material during high runoff conditions.
- (7) Conduct bedding operations in high-water-table areas during dry periods of the year. Conduct bedding in sloping areas on the contour.
- (8) Protect small ephemeral drainages when conducting mechanical tree planting.

1. Applicability

This management measure pertains to lands where silvicultural or forestry operations are planned or conducted. It is intended to apply to all site preparation and regeneration activities conducted as part of normal silvicultural activities on harvested units larger than 5 acres.

Under the Coastal Zone Act Reauthorization Amendments of 1990, States are subject to a number of requirements as they develop coastal nonpoint source programs in conformity with this measure and will have some flexibility in doing so. The application of this management measure by States is described more fully in *Coastal Nonpoint Pollution Control Program: Program Development and Approval Guidance*, published jointly by the U.S. Environmental Protection Agency (EPA) and the National Oceanic and Atmospheric Administration (NOAA) of the U.S. Department of Commerce.

2. Description

Regeneration of harvested forest lands not only is important in terms of restocking a valuable resource, but also is important to provide water quality protection from disturbed soils. Tree roots stabilize disturbed soils by holding the soil in place and aiding soil aggregation, decreasing slope failure potential. The presence of vegetation on disturbed soils also slows storm runoff, which in turn decreases erosion.

Leaving the forest floor litter layer intact during site preparation operations for regeneration minimizes mineral soil disturbance and detachment, thereby minimizing erosion and sedimentation (Golden et al., 1984). Maintenance of an unbroken litter layer prevents raindrop detachment, maintains infiltration, and slows runoff (McClurkin et al.,

1987). Mechanical site preparation can potentially impact water quality in areas that have steep slopes and erodible soils, and where the prepared site is located near a waterbody. Use of mechanical site preparation treatments that expose mineral soils on steep slopes can greatly increase erosion and landslide potential. Alternative methods, such as drum chopping, herbicide application, or prescribed burning, disturb the soil surface less than mechanical practices (Golden et al., 1984).

Mechanical planting using machines that scrape or plow the soil surface can produce erosion rills, increasing surface runoff and erosion. Natural regeneration, hand planting, and direct seeding minimize soil disturbance, especially on steep slopes with erodible soils (Golden et al., 1984).

3. Management Measure Selection

This measure is based in part on information and experience gained from studies and from the use of similar management practices by States. The information summarized provides comparisons and relative levels of effects and costs for site preparation and regeneration. The majority of the data in Tables 3-42 through 3-46 compare sediment loss or erosion rates for shearing, chopping, root-raking and disking. Many of the data are site-specific, and site characteristics and experimental conditions are provided (when available) in the text below. Regional differences in effects are summarized by Dissmeyer and Stump (1978); however, most of the experimental information is from the Southeast and Texas.

a. Effectiveness Information

Effects of different site preparation techniques depend greatly on care of application and site conditions. Beasley (1979) studied the relative soil disturbance effects of site preparation following clearcutting on three small watersheds in the hilly northern Mississippi Coastal Plain. Slopes were mostly 30 percent or greater. One site was single drum-chopped and burned; one was sheared and windrowed (windrows were burned); and the third was sheared, windrowed, and bedded to contour. The control watershed was instrumented and left uncut. The treatments exposed soil on approximately 40-70 percent of the three watersheds (Table 3-42). A temporary cover crop of clover was sown after site preparation to protect the soil from rainfall impact and erosion. Similar increases in sediment production were measured for the three treatments in the first year after site preparation, with amounts decreasing during the second year except for the bedded site, which was attributed to gully formation from increased stormflow. During the second year, the clover and other vegetation covered 85-95 percent of the surface, effectively decreasing sediment production.

A summary of work on erosion from site preparation by Dissmeyer and Stump is presented in Golden et al. (1984)(Table 3-43). These erosion rates were compiled from the Erosion Data Bank of the U.S. Forest Service and are based on observations throughout the Southeast. The rates reflect soil movement measured at the bottom of the slope, not sediment actually reaching a stream. Therefore, the numbers estimate the worst-case erosion if the stream is located directly at the toe of the slope with no intervening vegetation. Rates are given as tons per acre per year average for 3- to 4-year recovery periods.

The degree of erosion produced by site preparation practices is directly related to the amount of soil disturbed and the percentage of good ground cover remaining. Dissmeyer (1980) showed that disking produced more than twice the erosion rate of any other method (Table 3-44). Bulldozing, shearing, and sometimes grazing were associated with relatively high rates of erosion. Chopping or chopping and burning produced moderate erosion rates. Logging also produced moderate erosion rates in this study when it included the impact of skid and spin roads. The lowest rate of erosion is associated with burning.

Beasley and Granillo (1985) compared stormflow and sediment losses from mechanically and chemically prepared sites in southwest Arkansas (Table 3-45). Mechanical preparation (clearcutting followed by shearing, windrowing, and replanting with pine seedlings) significantly increased sediment losses in the first 2 years after treatment. A subsequent decline in sediment losses in the mechanically prepared watersheds was attributed to rapid growth of ground cover. Windrowing brush into ephemeral drainages and leaving it unburned effectively minimized soil losses

Table 3-42. Deposited, Suspended, and Total Sediment Losses and Percentage of Exposed Soil in the Experimental Watersheds During Water Years 1976 and 1977 for Various Site Preparation Techniques (MS, AR) (Beasley, 1979)

Treatment	Percent of Exposed Soil					
Chopped	37					
Sheared and windrowed	53					
Bedded	69					

Treatment	1976 (tons/ha)			1977 (tons/ha)		
	Deposited	Suspended	Total	Deposited	Suspended	Total
Control	--	--	0.62	--	--	0.11
Chopped	2.19	10.34	12.54	0.74	1.58	2.31
Sheared	2.14	10.65	12.80	0.81	1.41	2.22
Bedded	3.26	10.98	14.25	2.18	3.36	5.54

by trapping sediment on-site and reducing channel scouring. Chemical site preparation (herbicides) had no significant effect on sediment losses.

Water quality changes associated with two site preparation methods were studied by Blackburn, DeHaven, and Knight (1982). Table 3-46 shows that shearing and windrowing (which exposed 59 percent of the soil) can produce 400 times more sediment loadings than chopping (which exposed 16 percent of the soil) during site preparation. Total

Table 3-43. Predicted Erosion Rates^a Using Various Site Preparation Techniques for Physiographic Regions in the Southeastern United States (Golden et al., 1984)

Physiographic Regions	Treatment	Average Erosion Rate (tons/acre/year)
Ridge and Valley	Bulldozing	13.70
Sand Mountain	KG-blade	4.00
Southern Piedmont	Chopping	0.22
	Chop and burn	0.38
	KG-blade	1.80
	Disking	4.10
	Bulldozing	1.90
Southern Coastal Plain	Chopping	0.24
	Chop and burn	0.41
	KG-blade	0.65
	Disking	2.46
	Bulldozing	0.66
		0.89
Blackland Prairies, AL and MS	KG-blade	1.20
	Disking	3.30

^a Rates are averages for the recovery period.

Table 3-44. Erosion Rates for Site Preparation Practices in Selected Land Resource Areas in the Southeast (Dissmeyer, 1980)

Condition or Activity	Recovery Period (Years)	Erosion Rates by Land Resource Area (Tons/Acre/Year)						
		Ouachita Mtns	Southern Appalachians	Southern Coastal Plains	Southern MS Valley Silty Uplands	Southern Piedmont	Carolina & GA Sand Hills	Atlanta & Gulf Coast Flatwoods
Natural	--	0.00	0.00	0.00	0.05	0.00	0.00	0.00
Logged ^a	3	2.3	1.7	0.48	0.27	0.48	0.20	0.13
Burned	2	0.23	0.16	0.17	0.7	0.14	0.06	0.05
Chopped	3	0.60	--	0.24	--	0.22	0.36	0.05
Chopped and burned	3-4	1.7	--	0.41	--	0.38	--	0.15
Sheared	4	3.6	--	0.65	2.4	1.8	1.0	0.20
Disked	4	--	--	2.46	9.8	4.1	--	--
Bulldozed	4	--	--	0.89	--	1.9	--	--
Grazed	--	0.80	--	0.18	1.0	0.95	--	0.01

^a Includes the impact of skid and spur roads.

Table 3-45. Effectiveness of Chemical and Mechanical Site Preparation in Controlling Water Flows and Sediment Losses (AR) (Beasley and Granillo, 1985)

Water Year	Treatment	Annual Stormflow (in)		Annual Sediment Losses (lb/ac)	
		Mean	Std Dev	Mean	Std Dev
1981 (Pretreatment)	Clearcut - Mechanical ^a	5.7	5.0	56	56
	Clearcut - Chemical ^b	4.7	5.5	39	50
	Control	7.9	7.5	28	26
1982	Clearcut - Mechanical	12.8	10.7	477	460
	Clearcut - Chemical	6.2	5.8	224	196
	Control	6.3	5.4	64	79
1983	Clearcut - Mechanical	24.0	19.3	897	949
	Clearcut - Chemical	15.6	15.8	183	157
	Control	8.7	7.3	131	196
1984	Clearcut - Mechanical	19.7	16.6	275	160
	Clearcut - Chemical	10.2	8.0	80	80
	Control	10.3	7.2	41	59

^a Clearcutting followed by shearing, windrowing, and replanting with pine seedlings.

^b Clearcutting followed by chemical treatments (injection of residual trees and foliar and/or aerial spraying).

Table 3-46. Sediment Loss (kg/ha) in Stormflow by Site Treatment from January 1 to August 31, 1981 (TX) (Blackburn, DeHaven, and Knight, 1982)

Treatment	Watershed	Sediment Loss (kg/ha)		
		Suspended	Bedload	Total
Sheared and windrowed	1	815.2	643.5	1,458.7
	2	1,217.0	920.4	2,137.4
	3	<u>736.7</u>	<u>2,270.8</u>	<u>3,007.5</u>
	Mean	923.0	1,278.2	2,201.2
Chopped	5	5.3	0	5.3
	7	10.7	0	10.7
	9	<u>23.2</u>	<u>0</u>	<u>23.2</u>
	Mean	13.1	0	13.1
Undisturbed	4	1.1	0	1.1
	6	7.2	0	7.2
	8	<u>0.8</u>	<u>0</u>	<u>0.8</u>
	Mean	3.0	0	3.0

nitrogen losses were nearly 20 times greater from sheared than from undisturbed watersheds, and three times greater from sheared than from chopped (Table 3-47).

b. Cost Information

The way a site is prepared for reforestation can make a 3- to 14-foot difference in site index for pine in the Southeast (Dissmeyer and Foster, 1987). In an analysis of different site preparation techniques, Dissmeyer and Foster concluded that maintaining site quality yields larger trees and more valuable products (Table 3-48). The heavy site preparation methods required a greater initial investment than did the light site preparation methods, but did not yield a greater harvest. The cost-benefit for light site preparation was a 2.3 percent greater internal rate of return than that for heavy site preparation. Dissmeyer (1986) evaluated the economic benefits of erosion control with respect to different site preparation techniques. Increased timber production and savings in site preparation costs are returns the landowner can enjoy if care is taken to reduce soil exposure, displacement, and compaction (Table 3-49). Using light site preparation techniques such as chopping and light burn reduces erosion, increases the site index and the value of timber, and costs less per unit area treated. Heavy site preparation techniques such as shearing and windrowing remove nutrients, compact soil, increase erosion and site preparation costs, and result in a lower present net value for timber.

Table 3-47. Nutrient Loss (kg/ha) in Stormflow by Site Treatment from January 1 to August 31, 1981 (TX) (Blackburn, DeHaven, and Knight, 1982)

Treatment	Nitrates	Ammonia	Total-N	Ortho-P	Total-P	K	Ca	Mg	Na
Sheared and windrowed	0.227	0.114	2.145	0.033	0.197	4.40	0.72	1.45	1.36
Chopped	0.066	0.042	0.759	0.010	0.012	2.48	1.19	0.71	0.79
Undisturbed	0.001	0.007	0.115	0.001	0.002	0.29	0.19	0.21	0.18

Table 3-48. Analysis of Two Management Schedules Comparing Cost and Site Productivity in the Southeast (Dissmeyer and Foster, 1987)

Year	Silviculture Treatment	Light Site Preparation ^a		Heavy Site Preparation ^b	
		Investment Per Hectare ^c	Wood Produced M ³ /ha	Investment Per Hectare ^c	Wood Produced M ³ /ha
1984	Site Prep/Tree Planting	\$297		\$420	
1999	Thinning	\$252	64.2 pulpwood	\$180	46.0 pulpwood
2010	Thinning	\$256	22.3 saw timber 33.3 pulpwood	\$331	5.3 saw timber 22.0 pulpwood
2020	Final Harvest	\$2,422	133.5 saw timber 15.2 pulpwood	\$2,071	112.3 saw timber 22.0 pulpwood
Present Net Value (@ 4%)		\$623		\$304	
Internal Rate of Return		12.4% ^d		10.1%	

Adapted from Patterson, T. 1984. Dollars in Your Dirt. *Alabama's Treasured Forests*. Spring: 20-21.

^a Light site preparation includes chop and light burn or chop with herbicides, and reduces soil exposure and erosion.

^b Heavy site preparation includes bulldozing or windrowing or shearing and windrowing, and increases erosion and sediment yields over those for light site preparation.

^c 1984 dollars.

^d Based on 4% inflation rate assumed.

The U.S. Forest Service (1987) examined the costs of three alternatives to slash treatment: broadcast burn and protection of streamside management zones, yarding of unmerchantable material (YUM) of 15 inches in diameter or more, and YUM of 8 inches in diameter or more (Table 3-50). YUM alternatives cost approximately \$435-\$820/acre, in comparison to broadcast burning at \$900/acre. In addition, the YUM alternatives protect highly erodible soils from direct rainfall and runoff impacts, reduce fire hazards, meet air and water quality standards, and allow for the rapid establishment of seedlings on clearcuts.

Table 3-49. Site Preparation Comparison (VA, SC, NC) (Dissmeyer, 1986)

Treatment	Treatment Cost (\$/acre)	Erosion Index ^a
No site preparation	\$40	1.0
Burn only	\$45	1.1
Single chop and burn	\$80	2.3
Double chop and burn	\$120	3.0
Single shear and burn	\$145	4.3
Shear twice and burn	\$170	5.1
Rootrake and disk and burn	\$170	16.0
Rootrake and burn	\$170	16.0

^a The index is an expression of relative erosion potential resulting from each treatment.

Table 3-50. Comparison of Costs for Yarding Unmerchantable Material (YUM) vs. Broadcast Burning (OR) (USDA, 1987)

Activity	Broadcast Burn and Protect SMA	YUM 15" in Diameter and No Burn	YUM 8" in Diameter and No Burn
Broadcast burn	\$350/acre	N/A	N/A
SMA protection	\$450/acre	N/A	N/A
YUM, fell hardwood, lop and scatter	N/A	\$305/acre	\$700/acre
Planting cost	\$100/acre	\$130/acre	\$120/acre
Totals	\$900/acre	\$435/acre	\$820/acre

Tables 3-51 and 3-52 present comparisons of estimated total costs for different site preparation and regeneration practices, respectively, for which cost-share assistance is provided by the State of Minnesota through its Stewardship Incentives Program (SIP) (Minnesota Department of Natural Resources, 1991). Table 3-53 presents total costs of forest regeneration by various methods, along with the cost-share amount provided by the State of Illinois' SIP.

4. Practices

As discussed more fully at the beginning of this chapter and in Chapter 1, the following practices are described for illustrative purposes only. State programs need not require implementation of these practices. However, as a practical matter, EPA anticipates that the management measure set forth above generally will be implemented by applying one or more management practices appropriate to the source, location, and climate. The practices set forth below have been found by EPA to be representative of the types of practices that can be applied successfully to achieve the management measure described above.

a. Site Preparation Practices

■ *Mechanical site preparation should not be applied on slopes greater than 30 percent.*

On sloping terrain greater than 10 percent, or on highly erosive soils, operate mechanical site preparation equipment on the contour.

■ *Mechanical site preparation should not be conducted in SMAs.*

■ *Construct beds along the contour (Huff and Deal, 1982). Avoid connecting beds to drainage ditches or other waterways.*

■ *Use haystack piling where possible instead of windrows.*

Leave sufficient slash and duff on the site to provide good ground cover and minimize erosion from the harvest site. If the soil Basic Erosion Rate (BER) is low, leave at least 40 percent good ground cover; if the BER is medium, leave at least 50 percent good ground cover; if the BER is high, leave at least 60 percent good ground cover.

■ *Minimize incorporation of soil material into windrows and piles during their construction.*

**Table 3-51. Estimated Costs for Site Preparation (1991 Costs)
(Minnesota Department of Natural Resources, 1991)**

Site Preparation Practice	Total Cost ^a
Chemical	\$67.00/acre
Mechanical	
Light (includes hand site preparation)	\$47.00/acre
Heavy ^b	\$107.00/acre
Chemical-Mechanical ^b	\$113.00/acre

^a The costs shown represent the total cost of the practice. Calculations were made by dividing the maximum Federal cost share by 0.75 to get the total cost.

^b Where slope exceeds 20 percent or primary cover is standing hardwoods greater than 12 inches in diameter, the above may be increased by \$40.00 per acre.

**Table 3-52. Estimated Costs for Regeneration (1991 Costs)
(Minnesota Department of Natural Resources, 1991)**

Regeneration Practice	Total Cost ^a
Planting ^b	
Softwoods (when purchased from State nurseries)	\$21.00/100 seedlings planted
Hardwoods (when purchased from State nurseries)	\$29.00/100 seedlings planted
Softwoods (when purchased from private nurseries)	\$28.00/100 seedlings planted
Hardwoods (when purchased from private nurseries)	\$41.00/100 seedlings planted
Shrubs	\$40.00/100 seedlings planted
Seeding (includes both purchase of seed and seeding)	
Aerial seeding	\$23.00/acre
Cyclone seeding	\$40.00/acre
Hand or hot cap seeding	\$53.00/acre

^a The costs shown represent the total cost of the practice. Calculations were made by dividing the maximum Federal cost share by 0.75 to get the total cost.

^b Where planting is to be done on areas of heavy slash from recent harvesting operations or on areas with slopes over 30 percent or on sites having other particularly difficult planting conditions, the limits may be increased an additional \$10.00 per 100 seedlings planted and, where the planting has a guaranteed end result, the above rates may be increased by \$5.00 per 100 trees planted.

**Table 3-53. Cost-Share Information for Revegetation/Tree Planting (Illinois
Administrative Code, 1990)**

Practice Description	Cost-Share Amount ^a	Total Cost
Tree planting (trees and labor)		
No-cost planting stock	NTE \$70.00/acre	\$87.50/acre
Purchased planting stock	NTE \$170.00/acre	\$212.50/acre
Direct seeding (including seed collected or purchased plus labor and any machinery use)	NTE \$40.00/acre	\$50.00/acre

NTE = not to exceed.

^a Cost-share amounts represent 80 percent of the actual cost.

This can be accomplished by using a rake or, if use of a blade is unavoidable, keeping the blade above the soil surface and removing only the slash. Rapid site recovery and tree growth are promoted by the retention of nutrient-rich topsoil, and the effectiveness of the windrow in minimizing sedimentation is increased.

■ *Locate windrows and piles away from drainages to prevent movement of materials during high-runoff conditions.*

■ *Avoid mechanical site preparation operations during periods of saturated soil conditions that may cause rutting or accelerate soil erosion.*

■ *Do not place slash in natural drainages, and remove any slash that accidentally enters drainages.*

Slash can clog the channel and cause alterations in drainage configuration and increases in sedimentation. Extra organic material can lower the dissolved oxygen content of the stream. Slash also allows silt to accumulate in the drainage and to be carried into the stream during storm events.

■ *Provide filter strips of sufficient width to protect drainages that do not have SMAs from sedimentation by the 10-year storm.*

b. Practices for Regeneration

■ *Distribute seedlings evenly across the site.*

■ *Order seedlings well in advance of planting time to ensure their availability.*

■ *Hand plant highly erodible sites, steep slopes, and lands adjacent to stream channels (SMAs)(Yoho, 1980).*

■ *Operate planting machines along the contour to avoid ditch formation.*

- Soil conditions (slope, moisture conditions, etc.) should be suitable for adequate machine operation.
- Slits should be closed periodically to avoid channeling flow.

G. Fire Management

Prescribe fire for site preparation and control or suppress wildfire in a manner which reduces potential nonpoint source pollution of surface waters:

- (1) Intense prescribed fire should not cause excessive sedimentation due to the combined effect of removal of canopy species and the loss of soil-binding ability of subcanopy and herbaceous vegetation roots, especially in SMAs, in streamside vegetation for small ephemeral drainages, or on very steep slopes.
- (2) Prescriptions for prescribed fire should protect against excessive erosion or sedimentation to the extent practicable.
- (3) All bladed firelines, for prescribed fire and wildfire, should be plowed on contour or stabilized with water bars and/or other appropriate techniques if needed to control excessive sedimentation or erosion of the fireline.
- (4) Wildfire suppression and rehabilitation should consider possible NPS pollution of watercourses, while recognizing the safety and operational priorities of fighting wildfires.

1. Applicability

This management measure pertains to lands where silvicultural or forestry operations are planned or conducted. It is intended to apply to all prescribed burning conducted as part of normal silvicultural activities on harvested units larger than 5 acres and for wildfire suppression and rehabilitation on forest lands.

Under the Coastal Zone Act Reauthorization Amendments of 1990, States are subject to a number of requirements as they develop coastal nonpoint source programs in conformity with this measure and will have some flexibility in doing so. The application of this management measure by States is described more fully in *Coastal Nonpoint Pollution Control Program: Program Development and Approval Guidance*, published jointly by the U.S. Environmental Protection Agency (EPA) and the National Oceanic and Atmospheric Administration (NOAA) of the U.S. Department of Commerce.

2. Description

The goal of this management measure is to minimize potential NPS pollution and erosion resulting from prescribed fire for site preparation and from the methods used for wildfire control or suppression.

Prescribed burning is aimed at reducing slash and competition for nutrients among seedlings and protecting against wildfire. Slash burning destroys vegetation that reduces nitrogen-nitrate loadings. If uncontrolled, the burn may reach SMAs or highly erodible soils, causing increased sedimentation and erosion. Prescribed burning causes changes in the chemical cycling of elements by influencing biological and microclimate changes, volatilization, and mineralization processes.

The intensity and severity of burning and the proportion of the watershed burned are the major factors affecting the influence of prescribed burning on streamflow and water quality (Baker, 1990). Fires that burn intensely on steep slopes close to streams and that remove most of the forest floor and litter down to the mineral soil are most likely

to adversely affect water quality (Golden et al., 1984). The amount of erosion following a fire depends on the following:

- Amount of ground cover remaining on the soil;
- Steepness of slope;
- Time, amount, and intensity of rainfall;
- Intensity of fire;
- Inherent erodibility of the soil; and
- Rapidity of revegetation.

Mersereau and Dyrness (1972) found slash burning on steep slopes to contribute to surface soil movement by removing litter and vegetation, and baring 55 percent of the mineral soil. Richter and others (1982), however, found that periodic, low-intensity prescribed fires had little effect on water quality in the Atlantic and Gulf coastal plain. Revegetation of burned areas also drastically reduces sediment yield from prescribed burning and wildfires (Baker, 1990).

3. Management Measure Selection

This measure is based in part on information and experience gained from studies and from the use of similar management practices by States. To avoid many of the negative impacts from prescribed burning, Pope (1978) recommends that those in charge of managing the fire construct water diversions on firelines in steep terrain to drain the water away from the burn, leave an adequate strip of undisturbed surface between the prescribed burn area and water sources, and avoid intense fires on soils that are uncohesive and highly erodible.

Dyrness (1963) studied the effects of slash burning in the Pacific Northwest, finding that severe burning decreases soil porosity and infiltration capacity, thus increasing the potential for soil erosion. Clayton (1981) found that after the helicopter logging and broadcast burning of slash in the Idaho batholith, erosion increased approximately 10 times the natural rate for a short period of time as the result of to a high-intensity rain storm and then decreased substantially within the following year.

Feller (1981) examined the effects of (1) clearcutting and (2) clearcutting and slash burning on stream temperatures in southwestern British Columbia. Both treatments resulted in increased summer temperatures as well as daily temperature fluctuations. These effects lasted for 7 years in the case of the clearcut stream but longer in the case of the clearcut and slash-burned stream. Clearcutting increased winter temperatures, while slash burning decreased temperatures. The study concluded that clearcutting and slash burning had a greater impact on stream temperatures than did clearcutting alone.

Biswell and Schultz (1957) found that surface runoff and erosion in northern California ponderosa pine forests are not attributable to prescribed burning. While conducting observations during heavy rains, the authors found that the duff and debris left after burning were effective in maintaining high infiltration and percolation capacity, and they traced surface runoff to bare soil areas caused by human activity. A study by Page and Lindenmuth (1971) examined the effects of prescribed fire on vegetation and sediment on a watershed in the oak-mountain mahogany chaparral of central Arizona. The study found that the average sediment movement from the treated drainages during the 5-year period was 0.30 acre-feet per square mile per year, which is substantially less than the sediment loss of 3.2 acre-feet per square mile per year for the first 5 years following a wildfire in a comparable area in Arizona.

Stednick and others (1982) found increased concentrations of suspended sediments, phosphorus, and potassium in streamflows below the burned area after the slash burning of coastal hemlock-spruce forests of southeastern Alaska. Stream monitoring indicated an immediate flush of elements, followed by a slower release of these elements into surface water. No reduction in the nitrogen content or depth of the soil organic horizon was found, but there were significant reductions in the potassium and magnesium contents of the soil.

Minnesota's Landowner Forest Stewardship Plan (1991) estimates the cost for prescribed burning to be \$27/acre.

4. Practices

As discussed more fully at the beginning of this chapter and in Chapter 1, the following practices are described for illustrative purposes only. State programs need not require implementation of these practices. However, as a practical matter, EPA anticipates that the management measure set forth above generally will be implemented by applying one or more management practices appropriate to the source, location, and climate. The practices set forth below have been found by EPA to be representative of the types of practices that can be applied successfully to achieve the management measure described above.

a. Prescribed Fire Practices

■ *Carefully plan burning to adhere to weather, time of year, and fuel conditions that will help achieve the desired results and minimize impacts on water quality.*

Evaluate ground conditions to control the pattern and timing of the burn.

■ *Intense prescribed fire for site preparation should not be conducted in the SMA.*

■ *Piling and burning for slash removal purposes should not be conducted in the SMA.*

■ *Avoid construction of firelines in the SMA.*

■ *In prescriptions for burns, avoid conditions requiring extensive blading of firelines by heavy equipment.*

Use handlines, firebreaks, and hose lays to minimize blading of firelines.

■ *Use natural or in-place barriers (e.g., roads, streams, lakes, wetlands) as an acceptable way to minimize the need for fireline construction in situations where artificial construction of firelines will result in excessive erosion and sedimentation.*

■ *Construct firelines in a manner that minimizes erosion and sedimentation and prevents runoff from directly entering watercourses.*

- Locate firelines on the contour whenever possible, and avoid straight uphill-downhill placement.
- Install grades, ditches, and water bars while the line is being constructed.
- Install water bars on any fireline running up and down the slope, and direct runoff onto a filter strip or sideslope, not into a drainage (Huff and Deal, 1982).
- Construct firelines at a grade of 10 percent or less where possible.
- Adequately cross-ditch all firelines at the time of construction (Megahan, 1983).
- Construct simple diversion ditches or turnouts at intervals as needed to direct surface water off the plowed line and onto undisturbed forest cover for dispersion of water and soil particles.
- Construct firelines only as deep and wide as necessary to control the spread of the fire.

■ *Maintain the erosion control measures on firelines after the burn.*

■ *Revegetate firelines with adapted herbaceous species (Megahan, 1983).*

Refer to the Revegetation of Disturbed Areas management measure for more detailed information.

- *Execute the burn with a trained crew and avoid intense burning.*

Intense burning can accelerate erosion by consuming the organic cover.

- *Avoid burning on steep slopes with high-erosion-hazard areas or highly erodible soils.*

b. Wildfire Practices

- *Whenever possible avoid using fire-retardant chemicals in SMAs and over watercourses, and prevent their runoff into watercourses. Do not clean application equipment in watercourses or locations that drain into watercourses.*
- *Close water wells excavated for wildfire-suppression activities as soon as practical following fire control.*
- *Provide advance planning and training for firefighters that considers water quality impacts when fighting wildfires. This can include increasing awareness so direct application of fire retardants to waterbodies is avoided and firelines are placed in the least detrimental position.*

H. Revegetation of Disturbed Areas

Reduce erosion and sedimentation by rapid revegetation of areas disturbed by harvesting operations or road construction:

- (1) Revegetate disturbed areas (using seeding or planting) promptly after completion of the earth-disturbing activity. Local growing conditions will dictate the timing for establishment of vegetative cover.
- (2) Use mixes of species and treatments developed and tailored for successful vegetation establishment for the region or area.
- (3) Concentrate revegetation efforts initially on priority areas such as disturbed areas in SMAs or the steepest areas of disturbance near drainages.

1. Applicability

This management measure pertains to lands where silvicultural or forestry operations are planned or conducted. It is intended to apply to all disturbed areas resulting from harvesting, road building, and site preparation conducted as part of normal silvicultural activities. Disturbed areas are those localized areas within harvest units or road systems where mineral soil is exposed or agitated (e.g., road cuts, fill slopes, landing surfaces, cable corridors, or skid trail ruts).

Under the Coastal Zone Act Reauthorization Amendments of 1990, States are subject to a number of requirements as they develop coastal nonpoint source programs in conformity with this measure and will have some flexibility in doing so. The application of this management measure by States is described more fully in *Coastal Nonpoint Pollution Control Program: Program Development and Approval Guidance*, published jointly by the U.S. Environmental Protection Agency (EPA) and the National Oceanic and Atmospheric Administration (NOAA) of the U.S. Department of Commerce.

2. Description

Revegetation of areas of disturbed soil can successfully prevent sediment and pollutants associated with the sediment (such as phosphorus and nitrogen) from entering nearby surface waters. The vegetation controls soil erosion by dissipating the erosive forces of raindrops, reducing the velocity of surface runoff, stabilizing soil particles with roots, and contributing organic matter to the soil, which increases soil infiltration rates. In areas such as the Pacific Northwest, the construction of forest roads without revegetation has led to significant increases in stream sedimentation. According to Carr and Ballard (1980), studies have found that stream sedimentation increased 250 times during the first rainfalls following construction of a 2.5-km logging road within a 100-hectare watershed and remained higher than an undisturbed companion watershed for the next 2 years.

Vegetation can trap and prevent dry ravel from moving further downslope, and it produces organic matter that is incorporated into the soil, increasing infiltration rates (Berglund, 1978). Nutrient and soil losses to streams and lakes also can be reduced by revegetating burned, cut over, or otherwise disturbed areas (Crumrine, 1977). In some cases, double plantings are used: an early planting to establish erosion protection quickly and a later planting to provide more permanent protection (Hynson et al., 1982).

3. Management Measure Selection

a. Effectiveness Information

This measure is based in part on information and experience gained from studies and from the use of similar management practices by States. Significant reductions in soil erosion have been achieved by revegetating bare cut-and-fill slopes alongside forest roads. A study of forest roadside slopes at two sites on Vancouver Island, Canada, by Carr and Ballard (1980) found revegetation to be an effective management practice in preventing soil erosion. At the control sites where no plant cover was present, the soil eroded to an average depth of 2-3 cm over 7 months, amounting to an estimated soil loss of 345 cubic meters per kilometer of road. In contrast, sites with hydroseeding had a net accumulation of soil material. In terms of practices, a single hydroseeding application of both seed and fertilizer was as effective as sequential hydroseeding application of seed and fertilizer in terms of preventing soil erosion. The practice of mulching on non-gully-prone soils, as a supplement to hydroseeding, was found to be unnecessary because mulch is incorporated into the hydromulch.

Kuehn and Cobourn (1989) studied the Basic Erosion Rate (BER) for soils on commercial forest land in the Eldorado National Forest and concluded that good ground cover is key to reducing erosion. Figure 3-26 demonstrates the relationship between percent ground cover and slope, and the resulting soil loss. Good ground cover is defined as "living plants within 5 feet of the ground and litter or duff with a depth of 2 inches or more."

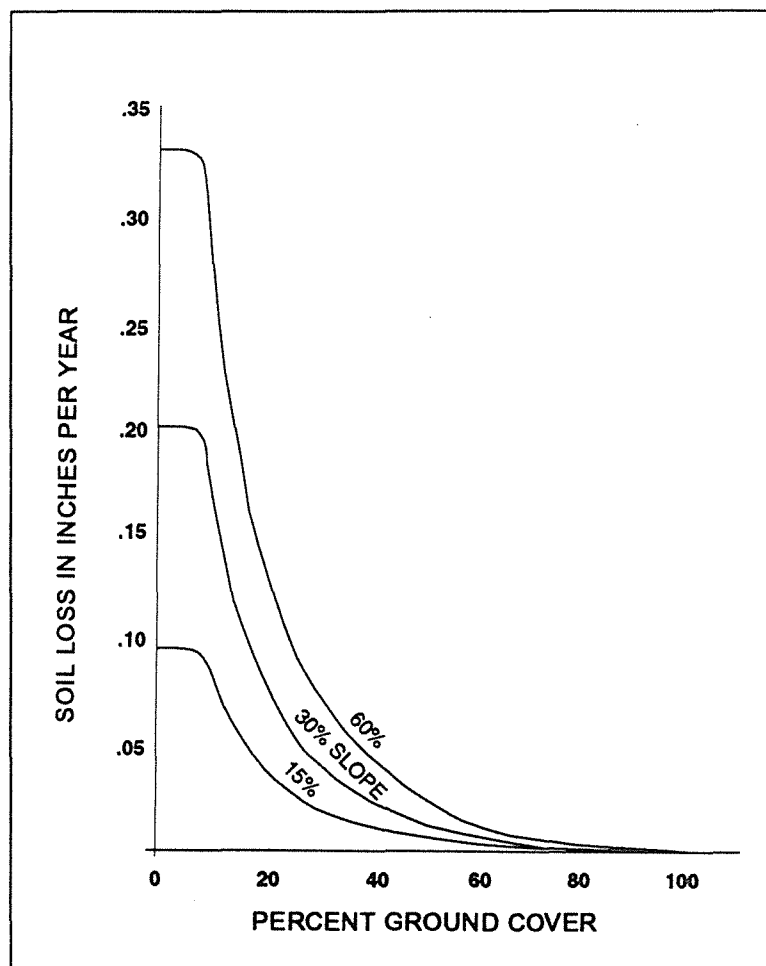

Figure 3-26. Relation of soil loss to good ground cover (Kuehn and Cobourn, 1989).

Seeding was also cited by Berglund (1978) as a successful management practice for controlling erosion along forest roads in Oregon. When establishing a revegetation erosion control program, the author suggested that the program address criteria for seed selection, site preparation guidelines, timing of seeding, application methods, fertilization, and mulching. Several guidelines for seed cover, fertilization, and mulching rates were also presented. For example, Berglund suggests that a vegetative cover of 40 percent or more is necessary to significantly reduce soil erosion from disturbed areas.

Bethlahmy and Kidd (1966) described the extent to which revegetation controls erosion from steep road fills as dependent upon the amount of protection given to the seeded slopes (Table 3-54). Seed and fertilizer alone did not control erosion, but the addition of straw mulch reduced erosion by one-eighth to one-half. Adding more protection, netting as well as mulch, reduced erosion by almost 100 percent to nearly negligible levels.

b. Cost Information

Megahan (1987) found the costs of seeding with plastic netting placed over the seeded area to be almost 50 times more than the costs of dry seeding alone (Table 3-55). The economic impacts of other revegetation management measures were estimated by Dubensky (1991)(Table 3-56). Seeding firelines or rough logging roads adds \$19.75 per 100 feet of road or fireline. Ripping, shaping, and seeding log decks costs about 178.50 per log deck. Fiber for road and landing maintenance adds \$4 per ton used, and water bars add \$12.50 each for construction and seeding.

Lickwar (1989) compared the costs for revegetation of disturbed areas for various slope gradients in the Southeast. He found that revegetation costs decreased slightly as slope decreased; however, costs remained fairly high (Table 3-57). Minnesota's Stewardship Incentives Program (SIP) estimated the costs of reestablishment of permanent vegetation to vary from \$80.00/acre to \$147.00/acre of disturbed area, depending on type of vegetation (Table 3-58).

Table 3-54. Comparison of the Effectiveness of Seed, Fertilizer, Mulch, and Netting in Controlling Cumulative Erosion from Treated Plots on a Steep Road Fill in Idaho (Bethlahmy and Kidd, 1966)

Cumulative Elapsed Time (days)	Cumulative Precipitation (inches)	Control Plot ^a	Erosion (in 1,000 lb/ac) by Plot Number ^b						
			Group A (seed, fertilizer)		Group B (seed, mulch, fertilizer)		Group C (seed, fertilizer, mulch, netting)		
			2	4	3	8	5	6	7
17	1.41	31.9	38.7	38.0	0.1	32.6	0	0	0
80	4.71	70.0	99.2	85.7	7.4	34.6	0.9	0	0.3
157	12.46	72.2	100.2	86.9	11.1	35.1	1.1	0	0.4
200	15.25	79.1	101.0	87.6	11.4	35.7	1.1	0	0.4
255	17.02	82.3	102.8	88.8	11.5	35.8	1.1	0	0.4
322	20.40	84.2	104.7	89.4	11.9	36.0	1.1	0	0.4

^a The control plot received no treatment at all.
^b Plot 2 had contour furrows, seed, fertilizer, holes.
 Plot 3 had contour furrows, straw mulch, seed, fertilizer, holes.
 Plot 4 had polymer emulsion, seed, fertilizer.
 Plot 5 had straw mulch, paper netting, seed, fertilizer.
 Plot 6 had straw mulch, jute netting, seed, fertilizer.
 Plot 7 had seed, fertilizer, straw mulch, chicken wire netting.
 Plot 8 had seed, fertilizer, straw mulch with asphalt emulsion.

Table 3-55. Costs of Erosion Control Measures (Megahan, 1987)

Measure ^a	Cost (\$/acre)
Dry seeding	124
Plastic netting placed over seeded area	5,662

^a Haber, D.F., and T. Kadoch. 1982. Costs of Erosion Control Measures Used on a Forest Road in the Silver Creek Watershed in Idaho, University of Idaho, Dept. of Civil Engineering.

Table 3-56. Economic Impact of Implementation of Proposed Management Measures on Road Construction and Maintenance (Dubensky, 1991)^a

Management Practice	Increased Cost
Fiber for road and landing construction/maintenance	\$4.00/ton
Ripping, shaping, and seeding log decks	\$178.50/deck
Seeding firelines or rough logging roads	\$19.75/100 ft
Construction and seeding of water bars	\$12.50 each
Construction of rolling dips on roads	\$19.75 each

^a Public comment information provided by the American Paper Institute and the National Forest Products Association.

Table 3-57. Cost Estimates (and Cost as a Percent of Gross Revenues) for Seed, Fertilizer, and Mulch (1987 Dollars) (Lickwar, 1989)

Practice Component	Steep Sites ^a	Moderate Sites ^b	Flat Sites ^c
Seed, fertilizer, and mulch	\$13,625.00 (3.41%)	\$12,849.95 (2.72%)	\$12,258.70 (1.36%)

^a Based on a 1,148-acre forest and gross harvest revenues of \$399,685. Slopes average over 9 percent.

^b Based on a 1,104-acre forest and gross harvest revenues of \$473,182. Slopes ranged from 4 percent to 8 percent.

^c Based on a 1,832-acre forest and gross harvest revenues of \$899,491. Slopes ranged from 0 percent to 3 percent.

Table 3-58. Estimated Costs for Revegetation (1991 Costs) (Minnesota Department of Natural Resources, 1991)

Practice	Total Cost ^a
Establishment of permanent vegetative cover (includes seedbed preparation, fertilizer, chemicals and application, seed, and seeding as prescribed in the plan)	
Introduced grasses	\$80.00/acre
Native grasses	\$147.00/acre

^a The costs shown represent the total cost of the practice. Calculations were made by dividing the maximum Federal cost share by 0.75 to obtain the total cost.

4. Practices

As described more fully at the beginning of this chapter and in Chapter 1, the following practices are described for illustrative purposes only. State programs need not require implementation of these practices. However, as a practical matter, EPA anticipates that the management measure set forth above generally will be implemented by applying one or more management practices appropriate to the source, location, and climate. The practices set forth below have been found by EPA to be representative of the types of practices that can be applied successfully to achieve the management measure described above.

■ *Use seed mixtures adapted to the site, and avoid the use of exotic species (Larse, 1971). Species should consist primarily of annuals to allow natural revegetation of native understory plants, and they should have adequate soil-binding properties.*

The selection of appropriate grasses and legumes is important for vegetation establishment. Grasses vary as to climatic adaptability, soil chemistry, and plant growth characteristics (Berglund, 1978). USDA Soil Service technical guides at the State-wide level are excellent sources of information for seeding mixtures and planting prescriptions (Hynson et al., 1982). The U.S. Forest Service, State foresters, and County Extension agents can also provide helpful suggestions (Kochenderfer, 1970). The use of native species is important and practical. Because non-native species can take over and destroy native vegetation, use of non-native species often results in increased maintenance activities and expense, and plenty of hardy native species are usually available (Hynson et al., 1982). In addition to selecting a seeding mixture, the seeding rate must be determined so that adequate soil protection can be achieved without the excess cost of overseeding. Berglund (1978) describes how to determine seeding rates in *Seeding to Control Erosion Along Forest Roads*.

■ *On steep slopes, use native woody plants planted in rows, cordons, or wattles.*

These species may be established more effectively than grass and are preferable for binding soils.

■ *Seed during optimum periods for establishment, preferably just prior to fall rains (Larse, 1971).*

Timing will depend on the species to be planted and the schedule of operations, which determines when protection is needed (Hynson et al., 1982).

■ *Mulch as needed to hold seed, retard rainfall impact, and preserve soil moisture (Larse, 1971).*

Critical, first-year mulch applications provide the necessary ground cover to curb erosion and aid plant establishment (Berglund, 1978). Many different kinds of mulches can be used to improve conditions for germination (Rothwell, 1978). Various materials, including straw, bark, and wood chips, can be used to temporarily stabilize fill slopes and other disturbed areas immediately after construction. In most cases, mulching is used in combination with seeding and planting to establish stable banks. Both the type and the amount of mulch applied vary considerably between regions and depend on the extent of the erosion potential and the available materials (Hynson et al., 1982). Figure 3-27 is a summary of mulching effectiveness in reducing erosion.

■ *Fertilize according to site-specific conditions.*

Fertilization is often necessary for successful grass establishment because road construction commonly results in the removal or burial of fertile topsoil (Berglund, 1978). To determine fertilizer formulations, it is best to compare available nitrogen, phosphorus, potassium, and sulphur in the soils to be treated with the requirements of the species to be sown (Rothwell, 1978). It may be necessary to refertilize periodically after vegetation establishment to maintain growth and erosion control capabilities (Larse, 1971; Berglund, 1978).

■ *Protect seeded areas from grazing and vehicle damage until plants are well established.*

If the stand is over 60 percent damaged, reestablish it following the original specifications.

■ *Inspect all seeded areas for failures, and make necessary repairs and reseed within the planting season.*

■ *During non-growing seasons, apply interim surface stabilization methods to control surface erosion.*

Possible methods include mulching (without seeding) and installation of commercially produced matting and blankets. Alternative methods for planting and seeding include hand operations, the use of a wide variety of mechanical seeders, and hydroseeding (Hynson et al., 1982).

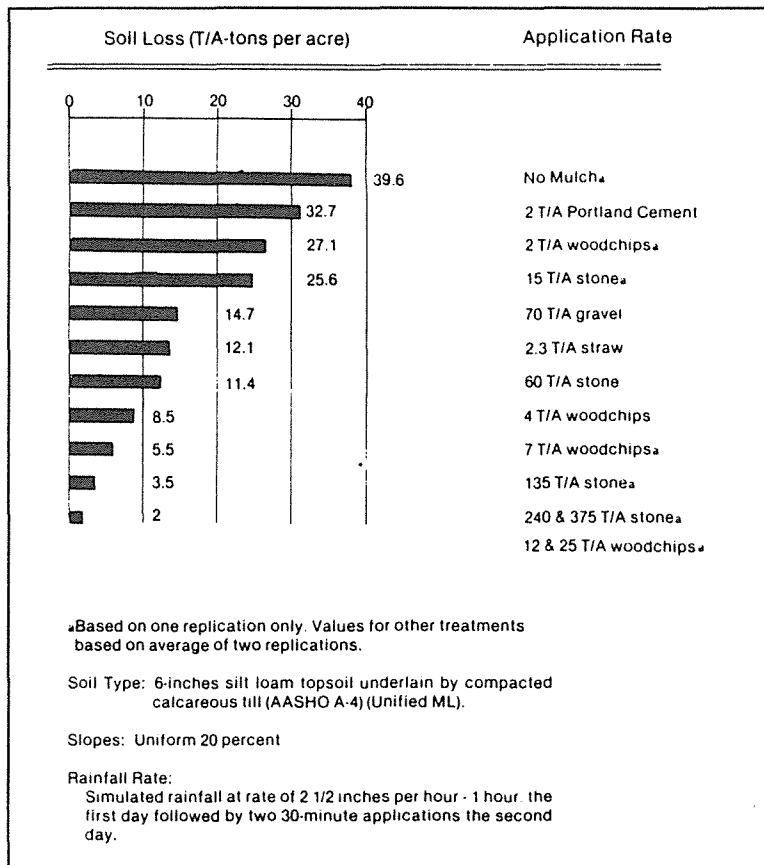

Figure 3-27. Soil losses from a 35-foot long slope by mulch type (Hynson et al., 1982).

I. Forest Chemical Management

Use chemicals when necessary for forest management in accordance with the following to reduce nonpoint source pollution impacts due to the movement of forest chemicals off-site during and after application:

- (1) Conduct applications by skilled and, where required, licensed applicators according to the registered use, with special consideration given to impacts to nearby surface waters.
- (2) Carefully prescribe the type and amount of pesticides appropriate for the insect, fungus, or herbaceous species.
- (3) Prior to applications of pesticides and fertilizers, inspect the mixing and loading process and the calibration of equipment, and identify the appropriate weather conditions, the spray area, and buffer areas for surface waters.
- (4) Establish and identify buffer areas for surface waters. (This is especially important for aerial applications.)
- (5) Immediately report accidental spills of pesticides or fertilizers into surface waters to the appropriate State agency. Develop an effective spill contingency plan to contain spills.

1. Applicability

This management measure pertains to lands where silvicultural or forestry operations are planned or conducted. It is intended to apply to all fertilizer and pesticide applications (including biological agents) conducted as part of normal silvicultural activities.

Under the Coastal Zone Act Reauthorization Amendments of 1990, States are subject to a number of requirements as they develop coastal nonpoint source programs in conformity with this measure and will have some flexibility in doing so. The application of this management measure by States is described more fully in *Coastal Nonpoint Pollution Control Program: Program Development and Approval Guidance*, published jointly by the U.S. Environmental Protection Agency (EPA) and the National Oceanic and Atmospheric Administration (NOAA) of the U.S. Department of Commerce.

2. Description

Chemicals used in forest management are generally pesticides (insecticides, herbicides, and fungicides) and fertilizers. Since pesticides may be toxic, they must be mixed, transported, loaded, and applied properly and their containers disposed of properly in order to prevent potential nonpoint source pollution. Since fertilizers may also be toxic or may shift the ecosystem energy dynamics, depending on the exposure and concentration, they must also be properly handled and applied.

Pesticides and fertilizers are occasionally introduced into forests to reduce mortality of desired tree species, improve forest production, and favor particular plant species. Many forest stands or sites never receive chemical treatment, and of those that do receive treatment, typically no more than two or three applications are made during an entire

tree rotation (40 to 120 years) (Megahan, 1980). Despite the low rate of applications in an area, pesticides can still accumulate within a watershed because there may be many forest sites that receive applications.

Although pesticides and fertilizers are used infrequently in forest operations, they can still pose a risk to the aquatic environment depending on the application technique used (Feller, 1989; Neary, 1985). These chemicals can directly enter surface waters through five major pathways: direct application, drift, mobilization in ephemeral streams, overland flow, and leaching. The input from direct application is the most important source of increased chemical concentrations and is also one of the most easily prevented.

Most adverse water quality effects related to the application of pesticides and fertilizers result from direct application of chemicals to surface waters or from chemical spills (Golden et al., 1984; Fredriksen et al., 1973; Norris and Moore, 1971). Hand application of herbicides generally poses little or no threat to water quality in areas where there is no potential for herbicides to wash into watercourses through gullies (Golden et al., 1984). Norris and Moore (1971) also found that providing buffer areas around streams and waterbodies effectively eliminated adverse water quality effects from forestry chemicals.

3. Management Measure Selection

This measure is based in part on information and experience gained from studies and from use of similar management practices by States. Information on the effects of various pesticide application and fertilization techniques on water quality are summarized in Tables 3-59 through 3-62. Many of the data presented are site-specific or lack clearly specified experimental conditions. However, general trends can be discerned among the studies, and general conclusions on the effectiveness of stream protection practices can be drawn.

a. Pesticide Effects

Most data show that the delivery of pesticides to surface waters from forestry operations is variable, depending on application technique, the presence or absence of buffers, and pesticide characteristics. The studies suggest that negative effects can be greatly reduced by taking precautions to avoid drift or direct application of chemicals to streams and other waterbodies. Norris and Moore (1971) noted that the concentration of 2,4-D in streams after aerial application was one to two orders of magnitude greater in forestry operations without buffers than in areas with buffers (Table 3-59). The elevated concentrations in the nonbuffered area returned to levels comparable to the buffered area after roughly 81 hours from the time of application. Fredriksen and others (1973) noted that in 8 years of monitoring Northwest forest streams for pesticide effects, no herbicide residues were detected in water column samples more than 1 month after aerial application. However, neither aquatic organisms nor sediments were sampled. Herbicide-induced changes in vegetation density and composition may cause indirect effects on streams such as increases in water temperature or nutrient concentration after desiccation of streamside vegetation. Use of unsprayed buffer strips should minimize these effects (Fredriksen et al., 1973).

Riekerk and others (1989) also found that the greatest risk to water quality from pesticide application in forestry operations occurs from aerial applications because of drift, wash-off, and erosion processes. As shown in Table 3-60, they found that aerial applications of herbicides resulted in a surface runoff concentration roughly 3.5 times greater than that of applications to the ground. They suggested that tree injection application methods would be considered the least hazardous for water pollution, but would also be the most labor-intensive.

Norris and others (1991) compiled information from multiple studies that evaluated the peak concentrations of herbicides, insecticides, and fertilizers in soils, lakes, and streams (Table 3-61). These studies were conducted from 1967 to 1987. Norris (1967) found that application of 2,4-D to marshy areas lead to higher-than-normal levels of stream contamination. When ephemeral streams were treated, residue levels of hexazinone and picloram greatly increased with storm-generated flow. Glyphosate was aerially applied (3.3 kg/hectare) to an 8-hectare forest ecosystem in the Oregon Coast Range. The study area contained two ponds and a small perennial stream. All were unbuffered and received direct application of the herbicide. Glyphosate residues were detected for 55 days after application with peak stream concentrations of 0.27 mg/L. It was demonstrated that the concentration of insecticides

**Table 3-59. Concentrations of 2,4-D After Aerial Application in Two Treatment Areas (OR)
(Norris and Moore, 1971)**

Treatment Without Buffers		Treatment With Buffers	
Time After Spraying (hr)	2,4-D (mg/l)	Time After Spraying (hr)	2,4-D (mg/l)
4.7	0.085	5.4	0.001
6.0	0.010	8.7	0.001
7.0	0.026	84.5	0.003
8.0	0.075	168.0	0
9.0	0.059		
13.9	0.051		
26.9	0.003		
37.9	0.009		
78.0	0.008		
80.8	0.001		
168.0	0		

in streams was significantly greater when the chemicals were applied without a buffer strip to protect the watercourse. When streams were unbuffered, the peak concentrations of malathion ranged from 0.037-0.042 mg/L. However, when buffers were provided, the concentrations of malathion were reduced to levels that ranged from undetectable to 0.017 mg/L. The peak concentrations of carbaryl ranged from 0.000-0.0008 mg/L when watercourses were protected with a buffer, but increased to 0.016 mg/L when watercourses were unbuffered.

Another study concluded that the effects of a pellet formulation of picloram applied to an Appalachian mountain forest did not produce any adverse effect on water quality within the 2-year study period (Neary et al., 1985). Similar results were found for a study on the application of sulfometuron methyl in Coastal Plain flatwoods (Neary et al., 1989). These researchers concluded that chemical application should not pose a threat to water quality when chemicals are applied at rates established on the product label and well away from flowing streams.

b. Fertilizer Effects

Moore (1971), as cited in Norris et al. (1991), compared nitrogen loss from a watershed treated with 224 kg urea-N per hectare to nitrogen loss from an untreated watershed. The study demonstrated that the loss of nitrogen from the fertilized watershed was 28.02 kg per hectare while the loss of nitrogen from the unfertilized watershed was only 2.15 kg per hectare (Table 3-62).

**Table 3-60. Peak Concentrations in Streamflow from Herbicide Application Methods
(Southeastern United States) (Riekerk et. al., 1989)**

Method	Residue Levels in Surface Runoff ($\mu\text{g/l}$)
Ground	< 36
Aerial	< 130

Table 3-61. Peak Concentrations of Forest Chemicals in Soils, Lakes, and Streams After Application (Norris et al., 1991)

Chemicals ^a and System ^b	Application Rate (kg/hectare)	Concentration (mg/L or mg/kg*)		Time Interval ^f	Time to Non-detection	Source ^d
		Peak	Subsequent			
Herbicides						
2,4-D	2.24	0.001-0.13			1-168 h ^e	17
Marsh	2.24	0.09				17,18
2,4-D BE						
Built pond	23.0					1
Water		3.0	1.0	85 d		
			0.2	180 d		
Sediment		8.0*	4.0*	13+ d		
			0.4-0.6*	82-182 d		
Aquatic plants			206*	7 d		
			8*	82 d	182 d	
2,4-D AS						
Reservoir		3.6	0	13 d		7
Picloram						
Runoff		0.078				19
Runoff		0.038				23
Ephemeral stream	2.8	0.32		157 d	915 d	9
Stream	0.37					3
Hexazinone						
Stream (GA)	1.68	0.044		3-4 m		11
Forest (GA)	1.68					14
Liter		0.177*	<0.01*	60+ d		
Soil		0.108*	<0.01*	90 d		
Ephemeral stream		0.514		3 d		
Perennial stream		0.442		3 d		
Atrazine						
Stream	3.0	0.42	0.02	17 d		16
Built ponds						10
Water		0.50	0.05	14 d		
			0.005	56 d		
Sediments		0.50*	0.9*	4 d		
		0.50*	0.25*	56 d		
Triclopyr						
Pasture (OR)	3.34	0.095*				20
Glyphosate						
Water	3.3	0.27	0.09	5.5 h		15
			<0.01	3 d		
Dalapon						
Field irrigation water		0.023-3.65	<0.01	Sev h		5

Table 3-61. (Continued)

Chemicals ^a and System ^b	Application Rate (kg/hectare)	Concentration (mg/L or mg/kg [*])		Time Interval ^c	Time to Non-detection	Source ^d
		Peak	Subsequent			
Insecticides						
Malathion						
Streams	0.91					24
Unbuffered		0.037-0.042				
Buffered		0-0.017				
Carbaryl						
Streams & ponds (E)		0-0.03				24
Streams, unbuffered (PNW)		0.005-0.011			48 h	24
Water	0.84	0.026-0.042				8
Brooks with buffer	0.84	0.001-0.008				22
Rivers with buffer	0.84	0.000-0.002				22
Streams, unbuffered	0.84	0.016				22
Ponds	0.84					6
Water		0.254			100-400 d	
Sediment		<0.01-5.0 ^{e,f}				
Acephate						
Streams		0.003-0.961				4
Streams	0.56	0.113-0.135	0.013-0.065	1 d		21
Pond sediment & fish				14 d		2
Fertilizers						
Urea	224					
Urea-N						
Forest stream (OR)		0.39	0.39	48 h		12
Dollar Cr (WA)		44.4				13
NH ₄ ⁺ -N						
Forest stream (OR)		<0.10				12
Tahuya Cr (WA)		1.4				13
NO ₃ ⁺ -N						
Forest stream (OR)		0.168				12
Elochoman R (WA)		4.0				13

^a 2,4-D BE = 2,4-D butoxyethanol ester; 2,4-D AS = 2,4-D amine salt + ester.

^b E = eastern USA; Cr = Creek; GA = Georgia; PNW = Pacific Northwest; OR = Oregon; R = River;

WA = Washington; buffer = wooded riparian strip.

^c d = day; h = hours; m = months; sev h = several hours. Intervals are times from application to measurement of peak or subsequent concentration, whichever is the last measurement indicated.

^d 1 = Birmingham and Colman (1985); 2 = Bocsor and O'Connor (1975); 3 = Davis et al. (1968); 4 = Flavell et al. (1977); 5 = Frank et al. (1970); 6 = Gibbs et al. (1984); 7 = Hoepfel and Westerdahl (1983); 8 = Hulbert (1978); 9 = Johnsen (1980); 10 = Maier-Bode (1972); 11 = Mayack et al. (1982); 12 = Moore (1970); 13 = Moore (1975b); 14 = Neary et al. (1983); 15 = Newton et al. (1984); 16 = M. Newton (Oregon State University, personal communication, 1967); 17 = Norris (1967); 18 = Norris (1968); 19 = Norris (1969); 20 = Norris et al. (1987); 21 = Rabeni and Stanley (1979); 22 = Stanley and Trial (1980); 23 = Suffling et al. (1974); 24 = Tracy et al. (1977).

^e Normally less than 48 h.

^f One extreme case: 23.8 mg/kg peak concentration, 16 months to nondetection.

Studies by Moore (Table 3-61) indicated that the concentrations of urea-N in runoff varied greatly, but that the greatest opportunity for water quality damage from fertilizer application occurred when the chemical directly entered

Table 3-62. Nitrogen Losses from Two Watersheds in Umpqua Experimental Watershed (OR) (Norris et al., 1991)

Loss Locus or Statistic	Urea-N	NH ₃ -N	NO ₃ -N	Total
Absolute loss (kg/hectare)				
Watershed 2 (treated)	0.65	0.28	27.09	28.02
Watershed 4 (untreated)	0.02	0.06	2.07	2.15
Net loss (2-4)	0.63	0.22	25.02	25.87
Proportional loss				
Percent of total	2.44	0.85	96.71	100.00

the waterbody. The peak concentrations were directly proportional to the amount of open surface water within the treated areas, and increases resulted almost entirely from direct applications to surface water. Megahan (1980) summarized data from Moore (1975), who examined changes in water quality following the fertilization of various forest stands with urea. The major observations from this research are summarized as follows (Megahan, 1980):

- Increases in the concentration of urea-N ranged from very low to a maximum of 44 ppm, with the highest concentrations attributed to direct application to water surfaces.
- Higher concentrations occurred in areas where buffer strips were not left beside streambanks.
- Chemical concentrations of urea and its by-products tended to be relatively short-lived due to transport downstream, assimilation by aquatic organisms, or adsorption by stream sediments.

Based on his literature review, Megahan (1980) concluded that the impacts of fertilizer application in forested areas could be significantly reduced by avoiding application techniques that could result in direct deposition into the waterbody and by maintaining a buffer area along the streambank. Malueg and others (1972) and Hetherington (1985) also presented information in support of Megahan's conclusions.

4. Practices

As discussed more fully at the beginning of this chapter and in Chapter 1, the following practices are described for illustrative purposes only. State programs need not require implementation of these practices. However, as a practical matter, EPA anticipates that the management measure set forth above generally will be implemented by applying one or more management practices appropriate to the source, location, and climate. The practices set forth below have been found by EPA to be representative of the types of practices that can be applied successfully to achieve the management measure described above.

■ *For aerial spray applications maintain and mark a buffer area of at least 50 feet around all watercourses and waterbodies to avoid drift or accidental application of chemicals directly to surface water.*

A wider buffer may be needed for major streams and lakes and for application of pesticides with high toxicity to aquatic life. A 100-foot buffer should be used for aerial applications and a 25-foot buffer used for ground spray. Aerial application methods require careful and precise marking of application areas to avoid accidental contamination of open waters (Riekerk, 1989). For specific applications such as hypo hatchet or wick applicator, buffer area widths used for spray applications may be reduced.

■ *Apply pesticides and fertilizers during favorable atmospheric conditions.*

- Do not apply pesticides when wind conditions increase the likelihood of significant drift.
- Avoid pesticide application when temperatures are high or relative humidity is low because these conditions influence the rate of evaporation and enhance losses of volatile pesticides.

■ *Users must abide by the current pesticide label which may specify: whether users must be trained and certified in the proper use of the pesticide; allowable use rates; safe handling, storage, and disposal requirements; and whether the pesticide can only be used under the provision of an approved Pesticide State Management Plan, management measures and practices for pesticides should be consistent with and/or complement those in the approved Pesticide State Management Plans.*

■ *Locate mixing and loading areas, and clean all mixing and loading equipment thoroughly after each use, in a location where pesticide residues will not enter streams or other waterbodies.*

■ *Dispose of pesticide wastes and containers according to State and Federal laws.*

■ *Take precautions to prevent leaks and/or spills.*

■ *Develop a spill contingency plan that provides for immediate spill containment and cleanup, and notification of proper authorities.*

An adequate spill and cleaning kit that includes the following should be maintained:

- Detergent or soap;
- Hand cleaner and water;
- Activated charcoal, adsorptive clay, vermiculite, kitty litter, sawdust, or other adsorptive materials;
- Lime or bleach to neutralize pesticides in emergency situations;
- Tools such as a shovel, broom, and dustpan and containers for disposal; and
- Proper protective clothing.

■ *Apply slow-release fertilizers, when possible.*

This practice will reduce potential nutrient leaching to ground water, and it will increase the availability of nutrients for plant uptake.

■ *Apply fertilizers during maximum plant uptake periods to minimize leaching.*

■ *Base fertilizer type and application rate on soil and/or foliar analysis.*

To determine fertilizer formulations, it is best to compare available nitrogen, phosphorus, potassium, and sulphur in the soils to be treated with the requirements of the species to be sown (Rothwell, 1978).

■ *Consider the use of pesticides as part of an overall program to control pest problems.*

Integrated Pest Management (IPM) strategies have been developed to control forest pests without total reliance on chemical pesticides. The IPM approach uses all available techniques, including chemical and nonchemical. An extensive knowledge of both the pest and the ecology of the affected environment is required for IPM to be effective.

A more in-depth discussion of IPM strategies and components can be found in the Pesticide management measure section of the Agriculture chapter of this guidance.

■ *Base selection of pesticide on site factors and pesticide characteristics.*

These factors include vegetation height, target pest, adsorption to soil organic matter, persistence or half-life, toxicity, and type of formulation.

■ *Check all application equipment carefully, particularly for leaking hoses and connections and plugged or worn nozzles. Calibrate spray equipment periodically to achieve uniform pesticide distribution and rate.*

■ *Always use pesticides in accordance with label instructions, and adhere to all Federal and State policies and regulations governing pesticide use.²*

5. Relationship of Management Measure Components for Pesticides to Other Programs

Under the Federal Insecticide, Fungicide and Rodenticide Act (FIFRA), EPA registers pesticides on the basis of evaluation of test data showing whether a pesticide has the potential to cause unreasonable adverse effects on humans, animals, or the environment. Data requirements include environmental fate data showing how the pesticide behaves in the environment, which are used to determine whether the pesticide poses a threat to ground water or surface water. If the pesticide is registered, EPA imposes enforceable label requirements, which can include, among other things, maximum rates of application, classification of the pesticide as a "restricted use" pesticide (which restricts use to certified applicators trained to handle toxic chemicals), or restrictions on use practices, including requiring compliance with EPA-approved Pesticide State Management Plans (described below). EPA and the U.S. Department of Agriculture Cooperative Extension Service provide assistance for pesticide applicator and certification training in each State.

FIFRA allows States to develop more stringent pesticide requirements than those required under FIFRA, and some States have chosen to do this. At a minimum, management measures and practices under State Coastal Nonpoint Source Programs must not be less stringent than FIFRA label requirements or any applicable State requirements.

EPA's *Pesticides and Groundwater Strategy* (USEPA, 1991) describes the policies and regulatory approaches EPA will use to protect the Nation's ground-water resources from risks of contamination by pesticides under FIFRA. The objective of the strategy is the prevention of ground-water contamination by regulating the use of certain pesticides (i.e., use according to EPA-approved labeling) in order to reduce and, if necessary, eliminate releases of the pesticide in areas vulnerable to contamination. Priority for protection will be based on currently used and reasonably expected sources of drinking water supplies, and ground water that is closely hydrogeologically connected to surface waters. EPA will use Maximum Contaminant Levels (MCLs) under the Safe Drinking Water Act as "reference points" for water resource protection efforts when the ground water in question is a current or reasonably expected source of drinking water.

The Strategy describes a significant new role for States in managing the use of pesticides to protect ground water from pesticides. In certain cases, when there is sufficient evidence that a particular use of a pesticide has the potential for ground-water contamination to the extent that it might cause unreasonable adverse effects, EPA may (through the use of existing statutory authority and regulations) limit legal use of the product to those States with an acceptable Pesticide State Management Plan, approved by EPA. Plans would tailor use to local hydrologic conditions and would address:

² The Federal Insecticide, Fungicide and Rodenticide Act governs the storage and application of pesticides.

- State philosophy;
- Roles and responsibilities of State and local agencies;
- Legal and enforcement authority;
- Basis for assessment and planning;
- Prevention measures;
- Ground-water monitoring;
- Response to detections;
- Information dissemination; and
- Public participation.

In the absence of such an approved Plan, affected pesticides could not be legally used in the State.

Since areas to be managed under Pesticide State Management Plans and Coastal Nonpoint Source Programs can overlap, State coastal zone and nonpoint source agencies should work with the State lead agency for pesticides (or the State agency that has a lead role in developing and implementing the Pesticide State Management Plan) in the development of pesticide management measure components and practices under both programs. This is necessary to avoid duplication of effort and conflicting pesticide requirements between programs. Further, ongoing coordination will be necessary since both programs and management measures will evolve and change with increasing technology and data.

J. Wetlands Forest

Plan, operate, and manage normal, ongoing forestry activities (including harvesting, road design and construction, site preparation and regeneration, and chemical management) to adequately protect the aquatic functions of forested wetlands.

1. Applicability

This management measure is intended for forested wetlands where silvicultural or forestry operations are planned or conducted. It is intended to apply specifically to forest management activities in forested wetlands and to supplement the previous management measures by addressing the operational circumstances and management practices appropriate for forested wetlands. Chapter 7 provides additional information on wetlands and wetland management measures for other, nonforestry source categories and activities.

Under the Coastal Zone Act Reauthorization Amendments of 1990, States are subject to a number of requirements as they develop coastal nonpoint source programs in conformity with this measure and will have some flexibility in doing so. The application of this management measure by States is described more fully in *Coastal Nonpoint Pollution Control Program: Program Development and Approval Guidance*, published jointly by the U.S. Environmental Protection Agency (EPA) and the National Oceanic and Atmospheric Administration (NOAA) of the U.S. Department of Commerce.

This management measure applies specifically to forest management activities in forested wetlands, including those currently undertaken under the exemptions of section 404(f) (40 CFR, Part 232). Many normal, ongoing forestry activities are exempt under section 404(f)(1) unless recaptured under the provisions of section 404(f)(2). This management measure is not intended to prohibit these silvicultural activities but to reduce incidental or indirect effects on aquatic functions as a result of these activities. Chapter 7 provides additional information on wetlands and wetland management measures for other, nonforestry source categories and activities.

2. Description

Forested wetlands provide many beneficial functions that need to be protected. Among these are floodflow alteration, sediment trapping, nutrient retention and removal, provision of important habitat for fish and wildlife, and provision of timber products (Clairain and Kleiss, 1989). The extent of palustrine (forested) wetlands in the continental United States has declined greatly in the past 40 years due to conversion to other land uses, with a net annual loss of 300,000 acres occurring between 1950 and 1970 (Frayar et al., 1983). Forested wetland productivity is dependent upon hydrologic conditions and nutrient cycling, and alteration of a wetland's hydrologic or nutrient-cycling processes can adversely affect wetland functions (Conner and Day, 1989). Refer to Chapter 7 for a wetland definition and a more complete description of the values and functions of wetlands.

The primary difference between forestry activities on wetland sites as compared to activities on upland sites is the result of flooding that occurs in most wetlands during some or most of the year. Potential impacts of forestry operations in wetlands include:

- Sediment production as a result of road construction and use and equipment operation;

- Drainage alteration as a result of improper road construction;
- Stream obstruction caused by failure to remove logging debris;
- Soil compaction caused by operation of logging vehicles during flooding periods or wet weather (skid trails, haul roads, and log landings are areas where compaction is most severe); and
- Contamination from improper application and/or use of pesticides.

The primary adverse impacts associated with road construction in forested wetlands are alteration of drainage and flow patterns, increased erosion and sedimentation, habitat degradation, and damage to existing timber stands. In an effort to prevent these adverse effects, section 404 of the Federal Water Pollution Control Act requires usage of appropriate BMPs for road construction and maintenance in wetlands so that flow and circulation patterns and chemical and biological characteristics are not impaired. Additional section 404(f) BMPs specific to forestry can be found at 40 CFR 232.3.

Harvest planning and selection of the right harvest system are essential in achieving the management objectives of timber production, ensuring stand establishment, and avoiding adverse impacts to water quality and wetland habitat.

The potential impacts of reproduction methods and cutting practices on wetlands include changes in water quality, temperature, nutrient cycling, and aquatic habitat (Toliver and Jackson, 1989). Streams can also become blocked with logging debris if SMAs are not properly maintained or if appropriate practices are not employed in SMAs.

Site preparation includes but is not limited to the use of prescribed fire, chemical, or mechanical site preparation. Extensive site preparation on bottoms where frequent flooding occurs can cause excessive erosion and stream siltation. The degree of acceptable site preparation is governed by the amount and frequency of flooding, soil type, and species suitability, and is dependent upon the regeneration method used.

Clean Water Act section 404 establishes a permit program that regulates the discharge of dredged or fill material into waters of the United States, including certain forested areas that meet the criteria for wetlands. Section 404(f)(1) of the Act provides an exemption from the permitting requirement for discharges in waters of the United States associated with normal, ongoing silviculture operations, including such practices as placement of bedding, cultivation, seeding, timber harvesting, and minor drainage. Section 404(f)(2) clarifies that discharges associated with silviculture activities identified at 404(f)(1) as exempt, are not eligible for the exemption if the proposed discharge involves toxic materials or if they would have the effect of converting waters of the United States, including wetlands, to dry land. Regulations implementing section 404(f), as well as describing applicable best management practices for avoiding impairment of the physical, chemical, and biological characteristics of the waters of the United States, were promulgated by EPA at 40 CFR Part 232.

3. Management Measure Selection

Mader and others (1989) assessed the relative impacts of various timber harvesting methods on different parameters in a forested wetland. On-site ecological responses on a clearcut site following timber harvesting with helicopter and rubber-tired skidder systems were compared to a clearcut, harvested, herbicide-treated area and an undisturbed stand in southwest Alabama. They found total nitrogen concentrations in soil water to be significantly lower for the skidder treatment when compared with all other treatments (Table 3-63). Total phosphorus concentrations were also significantly different for the helicopter treatment as compared to the control stand. Sediment accumulation was greatest for the helicopter treatment and least for the herbicide treatment, and all differences between treatments were significant.

Table 3-63. Total Nitrogen and Phosphorus Concentrations in Soil Water, and Sedimentation During Wet Season Flooding^a (Mader et al., 1989)

Treatment	n ^b	Nutrient Concentration (parts per million)		n	Sediment Accumulation (millimeters)
		TN ^c	TP ^d		
Herbicide	36	11.1 (2.1)	9.8 (2.6)	81	0.7 (0.3)
Skidder	36	7.4 (1.0)	10.1 (2.1)	81	1.2 (0.5)
Helicopter	36	10.6 (1.4)	11.4 (2.0)	81	2.2 (0.6)
Undisturbed	36	11.0 (1.6)	8.8 (2.0)	81	1.1 (0.1)

^a Values are treatment means (\pm SE) of nine replications.

^b n = Number of samples.

^c TN = Total nitrogen in soil water.

^d TP = Total phosphorus in soil water.

4. Practices

As discussed more fully at the beginning of this chapter and in Chapter 1, the following practices are described for illustrative purposes only. State programs need not require implementation of these practices. However, as a practical matter, EPA anticipates that the management measure set forth above generally will be implemented by applying one or more management practices appropriate to the source, location, and climate. The practices set forth below have been found by EPA to be representative of the types of practices that can be applied successfully to achieve the management measure described above.

a. Road Design and Construction Practices

■ *Locate and construct forest roads according to preharvest planning.*

Improperly constructed and located forest roads may cause changes in hydrology, accelerate erosion, reduce or degrade fisheries habitat, and destroy or damage existing stands of timber.

■ *Utilize temporary roads in forested wetlands.*

Permanent roads should be constructed only to serve large and frequently used areas, as approaches to watercourse crossings, or as access for fire protection. Use the minimum design standard necessary for reasonable safety and the anticipated traffic volume.

■ *Construct fill roads only when absolutely necessary for access since fill roads have the potential to restrict natural flow patterns.*

Where construction of fill roads is necessary, use a permeable fill material (such as gravel or crushed rock) for at least the first layer of fill. The use of pervious materials maintains the natural flow regimes of subsurface water. Figures 3-28 and 3-29 demonstrate the impact of impervious and pervious road fills on wetland hydrology. Permeable fill material is not a substitute for using bridges where needed, or for installation of adequately spaced culverts present at all natural drainageways. This practice should be used in conjunction with cross drainage structures to ensure that natural wetland flows are maintained (i.e., so that fill does not become clogged by sediment and obstruct flows (Hynson et al., 1982).

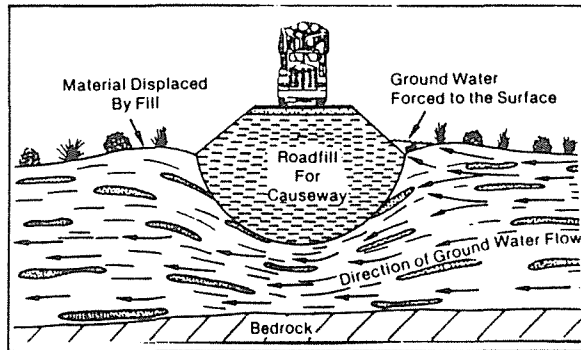

Figure 3-28. Impervious roadfill section placed on wetlands consisting of soft organic sediments with sand lenses. The natural material consolidates and restricts ground-water flow (Hynson et al., 1982).

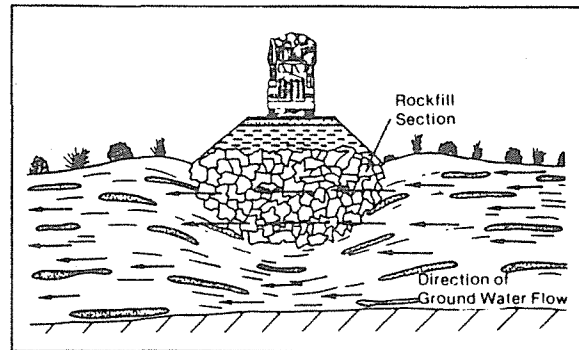

Figure 3-29. Pervious roadfill section on wetland allows movement of ground water through it and minimizes flow changes (Hynson et al., 1982).

■ Provide adequate cross drainage to maintain the natural surface and subsurface flow of the wetland.

This can be accomplished through adequate sizing and spacing of water crossing structures, proper choice of the type of crossing structure, and installation of drainage structures at a depth adequate to pass subsurface flow. Bridges, culverts, and other structures should not perceptibly diminish or increase the duration, direction, or magnitude of minimum, peak, or mean flow of water on either side of the structure (Hynson et al., 1982).

■ Construct roads at natural ground level to minimize the potential to restrict flowing water.

Float the access road fill on the natural root mat. If the consequences of the natural root mat failing are serious, use reinforcement materials such as geotextile fabric, geo-grid mats, or log corduroy. Figure 3-30 depicts a cross section

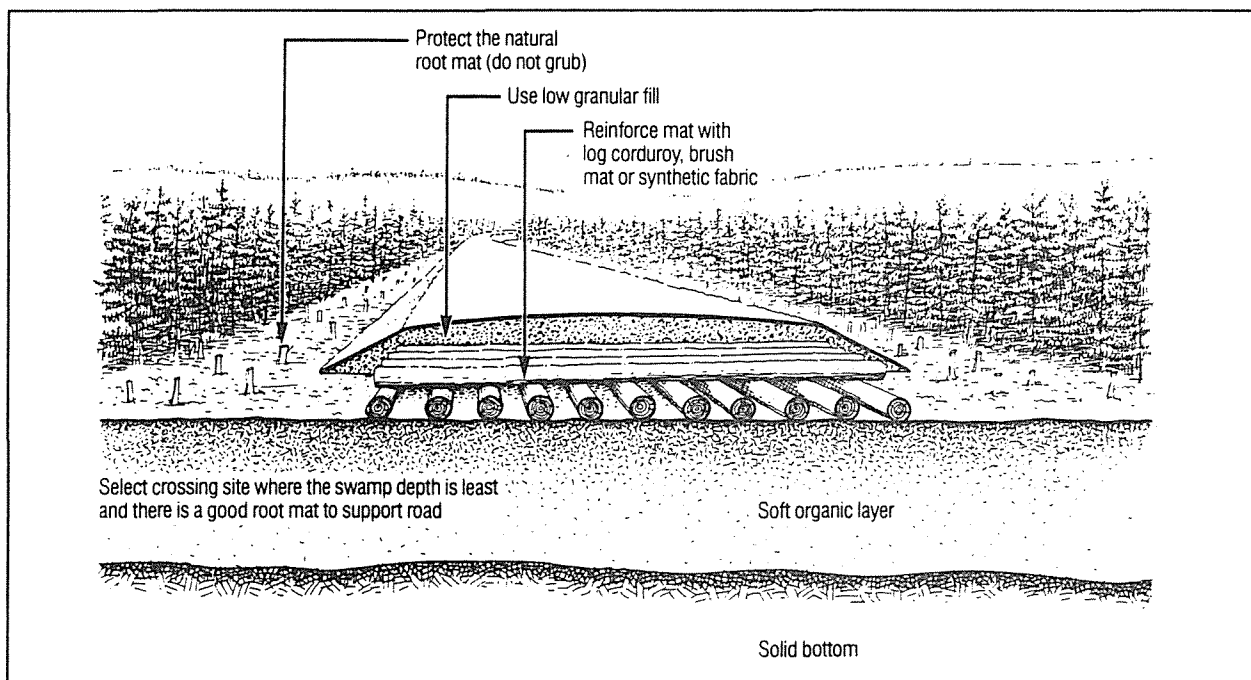

Figure 3-30. Cross section of a wetland road (Ontario Ministry of Natural Resources, 1988).

of the "floating the road" practice. Protect the root mat beneath the roadway from equipment damage. This can be facilitated by diverting through traffic to the edge of the right-of-way, shear-blading stumps instead of grubbing, and using special wide-pad equipment. Also, protect the root mat from damage or puncture by using fill material that does not contain large rocks or boulders.

b. Harvesting Practices

- *Conduct forest harvesting according to preharvest planning designs and locations.*

Planning and close supervision of harvesting operations are needed to protect site integrity and enhance regeneration. Harvesting without regard to season, soil type, or type of equipment can damage the site productivity; retard regeneration; cause excessive rutting, churning, and puddling of saturated soils; and increase erosion and siltation of streams.

- *Establish a streamside management area adjacent to natural perennial streams, lakes, ponds, and other standing water in the forested wetland following the components of the SMA management measure.*
- *Ensure that planned harvest activities or chemical use do not contribute to problems of cumulative effects in watersheds of concern.*
- *Select the harvesting method to minimize soil disturbance and hydrologic impacts to the wetland.*

In seasonally flooded wetlands, a guideline is to use conventional skidder logging that employs equipment with low-ground-pressure tires, cable logging, or aerial logging (Doolittle, 1990). Willingham (1989) compared cable logging to helicopter logging and concluded that helicopter operations caused less site disturbance, were more economical, and provided greater yield. Table 3-64 depicts harvesting systems recommended by the Florida Division of Forestry by type of forested wetland. These recommendations are based on both water quality and economic considerations. Another alternative is to conduct harvesting during winter months when the ground is frozen.

- *When groundskidding, use low-ground-pressure tires or tracked machines and concentrate skidding to a few primary skid trails to minimize site disturbance, soil compaction, and rutting.*
- *When soils become saturated, suspend groundskidding harvesting operations. Use of groundskidding equipment during excessively wet periods may result in unnecessary site disturbance and equipment damage.*

c. Site Preparation and Regeneration Practices

- *Select a regeneration method that meets the site characteristics and management objectives.*

Choice of regeneration method has a major influence on the stand composition and structure and on the silvicultural practices that will be applied over the life of the stand (Toliver and Jackson, 1989). Natural regeneration may be achieved by clearcutting the existing stand and relying on regeneration from seed from adjacent stands, the cut trees, or stumps and from root sprouts (coppice). Successful regeneration depends on recognizing the site type and its characteristics; evaluating the stocking and species composition in relation to stand age and site capability; planning regeneration options; and using sound harvesting methods. Schedule harvest during the dormant season to take advantage of seed sources and to favor coppice regeneration. Harvest trees at a stump height of 12 inches or less when practical to encourage vigorous coppice regeneration. Artificial regeneration may be accomplished by planting seedlings or direct seeding. Table 3-65 contains the regeneration system recommendations of the Georgia Forestry Association.

Table 3-64. Recommended Harvesting Systems by Forested Wetland Site^a
(Florida Department of Agriculture and Consumer Services, 1988)

Site Type	Conventional	Conventional with Controlled Access ^b	Cable or Aerial	Barge or High Flotation Boom
Flowing Water				
<i>Mineral Soil</i>				
Alluvial River Bottom	B	A	C	C
<i>Organic Soil</i>				
Black River Bottom	B	A	C	C
Branch Bottom	A ^c	B	C	C
Cypress Strand	B	A	A	A
Muck Swamp	C	A	A	A
Nonflowing Water				
<i>Mineral Soil</i>				
Wet Hammock	B	A	C	C
<i>Organic Soil</i>				
Cypress Dome	B	A	A	A
Peat Swamp	C	A	A	A

A = recommended; B = recommended when dry; C = not recommended.

^a Recommendations include cost considerations

^b Preplanned and designated skid trails and access roads.

^c Log from the hill (high ground).

■ *Conduct mechanized site preparation and planting sloping areas on the contour.*

■ *To reduce disturbance, conduct bedding operations in high-water-table areas during dry periods of the year.*

The degree of acceptable site preparation depends on the amount and frequency of flooding, the soil type, and the species suitability.

Minimize soil degradation by limiting operations on saturated soils.

d. Chemical Management Practices

■ *Apply herbicides by injection or application in pellet form to individual stems.*

■ *For chemical and aerial fertilizer applications, maintain and mark a buffer area of at least 50 feet around all surface water to avoid drift or accidental direct application.*

Avoid application of pesticides with high toxicity to aquatic life, especially aerial applications.

**Table 3-65. Recommended Regeneration Systems by Forested Wetland Type
(Georgia Forestry Association, 1990)**

Type	Natural Regeneration				Artificial Regeneration		
	Clearcut	Group Selection	Shelter Wood	Seed ^a Tree	Mechanical Site Prep.	Plant	Direct Seed
Flood Plains, Terraces, Bottomland							
Black River	A	B	B	C	D	C	C
Red River	A	B	B	C	D	B	B
Branch Bottoms	A	B	B	C	D	C	C
Piedmont Bottoms	A	B	B	C	D	B	B
Muck Swamps	A	C	C	C	D	C	C
Wet Flats							
Pine Hammocks & Savannahs	A	B	B	B	A	A	B
Pocosins or Bays	A	C	B	B	B	B	B
Cypress Strands	A	C	C	C	D	C	C
Cypress Domes: Peat Swamps							
Peat Swamps	A	C	C	C	C	C	C
Cypress Domes	A	C	C	C	D	C	C
Gulfs, Coves, Lower Slopes	A	B	B	C	C	B	C

A = highly effective; B = effective; C = less effective; D = not recommended.

^a Seed tree cuts are not recommended on first terraces of flood plains, terraces, and bottomland.

■ *Apply slow-release fertilizers, when possible.*

This practice will reduce the potential of the nutrients leaching to ground water, and it will increase the availability of nutrients for plant uptake.

■ *Apply fertilizers during maximum plant uptake periods to minimize leaching.*

■ *Base fertilizer type and application rate on soil and/or foliar analysis.*

To determine fertilizer formulations, it is best to compare available nitrogen, phosphorus, potassium, and sulphur in the soils to be treated with the requirements of the species to be sown.

III. GLOSSARY

Access road: A temporary or permanent road over which timber is transported from a loading site to a public road. Also known as a haul road.

Alignment: The horizontal route or direction of an access road.

Allochthonous: Derived from outside a system, such as leaves of terrestrial plants that fall into a stream.

Angle of repose: The maximum slope or angle at which a material, such as soil or loose rock, remains stable (stable angle).

Apron: Erosion protection placed below the streambed in an area of high flow velocity, such as downstream from a culvert.

Autochthonous: Derived from within a system, such as organic matter in a stream resulting from photosynthesis by aquatic plants.

Bedding: A site preparation technique whereby a small ridge of surface soil is formed to provide an elevated planting or seed bed. It is used primarily in wet areas to improve drainage and aeration for seeding.

Berm: A low earth fill constructed in the path of flowing water to divert its direction, or constructed to act as a counterweight beside the road fill to reduce the risk of foundation failure (buttress).

Borrow pit: An excavation site outside the limits of construction that provides necessary material, such as fill material for embankments.

Broad-based dip: A surface drainage structure specifically designed to drain water from an access road while vehicles maintain normal travel speeds.

Brush barrier: A sediment control structure created of slash materials piled at the toe slope of a road or at the outlets of culverts, turnouts, dips, and water bars.

Buck: To saw felled trees into predetermined lengths.

Buffer area: A designated area around a stream or waterbody of sufficient width to minimize entrance of forestry chemicals (fertilizers, pesticides, and fire retardants) into the waterbody.

Cable logging: A system of transporting logs from stump to landing by means of steel cables and winch. This method is usually preferred on steep slopes, wet areas, and erodible soils where tractor logging cannot be carried out effectively.

Check dam: A small dam constructed in a gully to decrease the flow velocity, minimize channel scour, and promote deposition of sediment.

Chopping: A mechanical treatment whereby vegetation is concentrated near the ground and incorporated into the soil to facilitate burning or seedling establishment.

Clearcutting: A silvicultural system in which all merchantable trees are harvested within a specified area in one operation to create an even-aged stand.

Contour: An imaginary line on the surface of the earth connecting points of the same elevation. A line drawn on a map connecting the points of the same elevation.

Crown: A convex road surface that allows runoff to drain to either side of the road prism.

Culvert: A metal, wooden, plastic, or concrete conduit through which surface water can flow under or across roads.

Cumulative effect: The impact on the environment that results from the incremental impact of an action when added to other past, present, and reasonably foreseeable future actions regardless of what agency or person undertakes such action.

Cut-and-fill: Earth-moving process that entails excavating part of an area and using the excavated material for adjacent embankments or fill areas.

DBH: Diameter at breast height; the average diameter (outside the bark) of a tree 4.5 feet above mean ground level.

Disking (harrowing): A mechanical method of scarifying the soil to reduce competing vegetation and to prepare a site to be seeded or planted.

Diversion: A channel with a supporting ridge on the lower side constructed across or at the bottom of a slope for the purpose of intercepting surface runoff.

Drainage structure: Any device or land form constructed to intercept and/or aid surface water drainage.

Duff: The accumulation of needles, leaves, and decaying matter on the forest floor.

Ephemeral stream: A channel that carries water only during and immediately following rainstorms. Sometimes referred to as a dry wash.

Felling: The process of cutting down standing trees.

Fill slope: The surface formed where earth is deposited to build a road or trail.

Firebreak: Naturally occurring or man-made barrier to the spread of fire.

Fireline: A barrier used to stop the spread of fire constructed by removing fuel or rendering fuel inflammable by use of fire retardants.

Ford: Submerged stream crossing where tread is reinforced to bear intended traffic.

Forest filter strip: Area between a stream and construction activities that achieves sediment control by using the natural filtering capabilities of the forest floor and litter.

Forwarding: The operation of moving timber products from the stump to a landing for further transport.

Geotextile: A product used as a soil reinforcement agent and as a filter medium. It is made of synthetic fibers manufactured in a woven or loose nonwoven manner to form a blanket-like product.

Grade (gradient): The slope of a road or trail expressed as a percentage of change in elevation per unit of distance traveled.

Harvesting: The felling, skidding, processing, loading, and transporting of forest products.

Haul road: See *access road*.

Intermittent stream: A watercourse that flows in a well-defined channel only in direct response to a precipitation event. It is dry for a large part of the year.

Landing (log deck): A place in or near the forest where logs are gathered for further processing or transport.

Leaching: Downward movement of a soluble material through the soil as a result of water movement.

Logging debris (slash): The unwanted, unutilized, and generally unmerchantable accumulation of woody material, such as large limbs, tops, cull logs, and stumps, that remains as forest residue after timber harvesting.

Merchantable: Forest products suitable for marketing under local economic conditions. With respect to a single tree, it means the parts of the bole or stem suitable for sale.

Mineral soil: Organic-free soil that contains rock less than 2 inches in maximum dimension.

Mulch: A natural or artificial layer of plant residue or other materials covering the land surface that conserves moisture, holds soil in place, aids in establishing plant cover, and minimizes temperature fluctuations.

Mulching: Providing any loose covering for exposed forest soils, such as grass, straw, bark, or wood fibers, to help control erosion and protect exposed soil.

Muskeg: A type of bog that has developed over thousands of years in depressions, on flat areas, and on gentle to steep slopes. These bogs have poorly drained, acidic, organic soils supporting vegetation that can be (1) predominantly sphagnum moss; (2) herbaceous plants, sedges, and rushes; (3) predominantly sedges and rushes; or (4) a combination of sphagnum moss and herbaceous plants. These bogs may have some shrub and stunted conifers, but not enough to classify them as forested lands.

Ordinary high water mark: An elevation that marks the boundary of a lake, marsh, or streambed. It is the highest level at which the water has remained long enough to leave its mark on the landscape. Typically, it is the point where the natural vegetation changes from predominantly aquatic to predominantly terrestrial.

Organic debris: Particles of vegetation or other biological material that can degrade water quality by decreasing dissolved oxygen and by releasing organic solutes during leaching.

Outslope: To shape the road surface to cause drainage to flow toward the outside shoulder.

Patch cutting method: A silvicultural system in which all merchantable trees are harvested over a specified area at one time.

Perennial stream: A watercourse that flows throughout a majority of the year in a well-defined channel.

Persistence: The relative ability of a pesticide to remain active over a period of time.

Pioneer roads: Temporary access ways used to facilitate construction equipment access when building permanent roads.

Prescribed burning: Skillful application of fire to natural fuels that allows confinement of the fire to a predetermined area and at the same time produces certain planned benefits.

Raking: A mechanical method of removing stumps, roots, and slash from a future planting site.

Regeneration: The process of replacing older trees removed by harvest or disaster with young trees.

Residual trees: Live trees left standing after the completion of harvesting.

Right-of-way: The cleared area along the road alignment that contains the roadbed, ditches, road slopes, and back slopes.

Riprap: Rock or other large aggregate that is placed to protect streambanks, bridge abutments, or other erodible sites from runoff or wave action.

Rut: A depression in access roads made by continuous passage of logging vehicles.

Salvage harvest: Removal of trees that are dead, damaged, or imminently threatened with death or damage in order to use the wood before it is rendered valueless by natural decay agents.

Sanitation harvest: Removal of trees that are under attack by or highly susceptible to insect and disease agents in order to check the spread of such agents.

Scarification: The process of removing the forest floor or mixing it with the mineral soil by mechanical action preparatory to natural or direct seeding or the planting of tree seedlings.

Scour: Soil erosion when it occurs underwater, as in the case of a streambed.

Seed bed: The soil prepared by natural or artificial means to promote the germination of seeds and the growth of seedlings.

Seed tree method: Removal of the mature timber in one cutting, except for a limited number of seed trees left singly or in small groups.

Selection method: An uneven-aged silvicultural system in which mature trees are removed, individually or in small groups, from a given tract of forestland over regular intervals of time.

Shearing: A site preparation method that involves the cutting of brush, trees, or other vegetation at ground level using tractors equipped with angles or V-shaped cutting blades.

Shelterwood method: Removal of the mature timber in a series of cuttings that extend over a relatively short portion of the rotation in order to encourage the establishment of essentially even-aged reproduction under the partial shelter of seed trees.

Silt fence: A temporary barrier used to intercept sediment-laden runoff from small areas.

Silvicultural system: A process, following accepted silvicultural principles, whereby the tree species constituting forests are tended, harvested, and replaced. Usually defined by, but not limited to, the method of regeneration.

Site preparation: A silvicultural activity to remove unwanted vegetation and other material, and to cultivate or prepare the soil for regeneration.

Skid: Short-distance moving of logs or felled trees from the stump to a point of loading.

Skid trail: A temporary, nonstructural pathway over forest soil used to drag felled trees or logs to the landing.

Slash: See *logging debris*.

Slope: Degree of deviation of a surface from the horizontal, measured as a numerical ratio, as a percent, or in degrees. Expressed as a ratio, the first number is the horizontal distance (run) and the second number is the vertical

distance (rise), as 2:1. A 2:1 slope is a 50 percent slope. Expressed in degrees, the slope is the angle from the horizontal plane, with a 90 degree slope being vertical (maximum) and a 45 degree slope being a 1:1 slope.

Stand: A contiguous group of trees sufficiently uniform in species composition, arrangement of age classes, and condition to be a homogeneous and distinguishable unit.

Streamside management area (SMA): A designated area that consists of the stream itself and an adjacent area of varying width where management practices that might affect water quality, fish, or other aquatic resources are modified. The SMA is not an area of exclusion, but an area of closely managed activity. It is an area that acts as an effective filter and absorptive zone for sediments; maintains shade; protects aquatic and terrestrial riparian habitats; protects channels and streambanks; and promotes floodplain stability.

Tread: Load-bearing surface of a trail or road.

Turnout: A drainage ditch that drains water away from roads and road ditches.

Water bar: A diversion ditch and/or hump installed across a trail or road to divert runoff from the surface before the flow gains enough volume and velocity to cause soil movement and erosion, and deposit the runoff into a dispersion area. Water bars are most frequently used on retired roads, trails, and landings.

Watercourse: A definite channel with bed and banks within which concentrated water flows continuously, frequently or infrequently.

Windrow: Logging debris and unmerchantable woody vegetation that has been piled in rows to decompose or to be burned; or the act of constructing these piles.

Yarding: Method of transport from harvest area to storage landing.

IV. REFERENCES

- Adams, P.W. 1991. Maintaining Woodland Roads. *The Woodland Workbook*. Oregon State University Extension Service, Extension Circular 1139.
- Alabama Forestry Commission. 1989. *Water Quality Management Guidelines and Best Management Practices for Alabama Wetlands*.
- Baker, M.B. 1990. *Hydrologic and Water Quality Effects of Fire*. USDA Forest Service, Rocky Mountain Forest and Range Experiment Station. General Technical Report RM-191, pp. 31-42.
- Beasley, R.S. 1979. Intensive Site Preparation and Sediment Loss on Steep Watersheds in the Gulf Coast Plain. *Soil Science Society of America Journal*, 43(3):412-417.
- Beasley, R.S., and A.B. Granillo. 1985. Water Yields and Sediment Losses from Chemical and Mechanical Site Preparation. In *Forestry and Water Quality - A Mid-South Symposium*, Arkansas Cooperative Extension Service, pp.106-116.
- Beasley, R.S., and A.B. Granillo. 1988. Sediment and Water Yields from Managed Forests on Flat Coastal Plain Soils. *Water Resources Bulletin*, 24(2):361-366.
- Beasley, R.S., E.L. Miller, and S.C. Gough. 1984. Forest Road Erosion in the Ouachita Mountains. In *Mountain Logging Symposium Proceeding, June 5-7, 1984*, ed. P.A. Peters and J. Luckok, pp.203-213. West Virginia University.
- Berglund, E.R. 1978. *Seeding to Control Erosion Along Forest Roads*. Oregon State University Extension Service, Extension Circular 885.
- Bethlahmy, N., and W.J. Kidd, Jr. 1966. *Controlling Soil Movement from Steep Road Fills*. USDA Forest Service Research Note INT-45.
- Bilby, R.E. 1984. Removal of Woody Debris May Affect Stream Channel Stability. *Journal of Forestry*, 609-613.
- Biswell, H.H., and A.M. Schultz. 1957. Surface Runoff and Erosion as Related to Prescribed Burning. *Journal of Forestry*, 55:372-374.
- Blackburn, W.H., M.G. DeHaven, and R.W. Knight. 1982. Forest Site Preparation and Water Quality in Texas. In *Proceedings of the Specialty Conference on Environmentally Sound Water and Soil Management*, ASCE, Orlando, Florida, July 20-23, 1982, ed. E.G. Kruse, C.R. Burdick, and Y.A. Yousef, pp. 57-66.
- Brazier, J.R., and G.W. Brown. 1973. *Buffer Strips for Stream Temperature Control*. Oregon State University School of Forestry, Forest Research Laboratory, Corvallis, OR, Research Paper 15.
- Brown, G.W. 1972. Logging and Water Quality in the Pacific Northwest. In *Watersheds in Transition Symposium Proceedings, Urbana, IL*, pp. 330-334. American Water Resources Association.
- Brown, G.W. 1974. *Fish Habitat*. USDA Forest Service. General Technical Report PNW-24, pp. E1-E15.
- Brown, G.W. 1985. Controlling Nonpoint Source Pollution from Silvicultural Operations: What We Know and Don't Know. In *Perspectives on Nonpoint Source Pollution*, pp. 332-333. U.S. Environmental Protection Agency.
- Brown, G.W., and J.T. Krygier. 1970. Effects of Clearcutting on Stream Temperature. *Water Resources Research*, 6(4):1133-1140.

- Brown, G.W., and J.T. Krygier. 1971. Clear-cut Logging and Sediment Production in the Oregon Coast Range. *Water Resources Research*, 7(5):1189-1199.
- California Department of Forestry and Fire Protection. 1991. *California Forest Practice Rules*.
- Carr, W.W., and T.M. Ballard. 1980. Hydroseeding Forest Roadsides in British Columbia for Erosion Control. *Journal of Soil and Water Conservation*, 35(1):33-35.
- Clairain, E.J., and B.A. Kleiss. 1989. Functions and Values of Bottomland Hardwood Forests Along the Cache River, Arkansas: Implications for Management. In *Proceedings of the Symposium: The Forested Wetlands of the Southern United States, Orlando, Florida, July 12-14, 1988*. USDA Forest Service General Technical Report SE-50, pp. 27-33.
- Clayton, J.L. 1981. *Soil Disturbance Caused by Clearcutting and Helicopter Yarding in the Idaho Batholith*. USDA Forest Service Research Note INT-305.
- Coats, R.N., and T.O. Miller. 1981. Cumulative Silvicultural Impacts on Watersheds: A Hydrologic and Regulatory Dilemma. *Environmental Management*, 5(2):147-160.
- Connecticut Resource Conservation and Development Forestry Committee. 1990. *A Practical Guide for Protecting Water Quality While Harvesting Forest Products*.
- Conner, W.H., and J.W. Day, Jr. 1989. Response of Coastal Wetland Forests to Human and Natural Changes in the Environment With Emphasis on Hydrology. In *Proceedings of the Symposium: The Forested Wetlands of the Southern United States, Orlando, Florida, July 12-14, 1988*. USDA Forest Service General Technical Report SE-50, pp. 34-43.
- Corbett, E.S., and J.A. Lynch. 1985. Management of Streamside Zones on Municipal Watersheds. In *Conference on Riparian Ecosystems and their Management: Reconciling Conflicting Uses, April 16-18, Tucson, Arizona*, pp. 187-190.
- Crumrine, J.P. 1977. Best Management Practices for the Production of Forest Products and Water Quality. In *"208" Symposium on Non-Point Sources of Pollution from Forested Land*, ed. G.M. Aubertin, Southern Illinois University, Carbondale, IL, pp. 267-274.
- Cubbage, F.W., W.C. Siegel, and P.M. Lickwar. 1989. State Water Quality Laws and Programs to Control Nonpoint Source Pollution from Forest Lands in the South. In *Water: Laws and Management*, ed. F.E. Davis, pp. 8A-29 to 8A-37. American Water Resources Association.
- Cullen, J.B. Undated. *Best Management Practices for Erosion Control on Timber Harvesting Operations in New Hampshire, Resource Manual*. New Hampshire Department of Resources and Economic Development, Division of Forests and Lands, Forest Information and Planning Bureau.
- Curtis, J.G., D.W. Pelren, D.B. George, V.D. Adams, and J.B. Layzer. 1990. *Effectiveness of Best Management Practices in Preventing Degradation of Streams Caused by Silvicultural Activities in Pickett State Forest, Tennessee*. Tennessee Technological University, Center for the Management, Utilization and Protection of Water Resources.
- Delaware Forestry Association. 1982. *Forestry Best Management Practices for Delaware*.
- Dickerson, B.P. 1975. Stormflows and Erosion after Tree-Length Skidding on Coastal Plains Soils. *Transactions of the ASAE*, 18:867-868,872.

- Dissmeyer, G.E. 1980. Predicted Erosion Rates for Forest Management Activities and Conditions in the Southeast. In *U.S. Forestry and Water Quality: What Course in the 80s? Proceedings*, Richmond, VA, June 19-20, 1980, pp. 42-49. Water Pollution Control Federation.
- Dissmeyer, G.E. 1986. Economic impacts of erosion control in forests. In *Proceedings of the Southern Forestry Symposium, November 19-21, 1985, Atlanta, GA*, ed. S. Carpenter, Oklahoma State University Agricultural Conference Series, pp. 262-287.
- Dissmeyer, G.E., and B. Foster. 1987. Some Economic Benefits of Protecting Water Quality. In *Managing Southern Forests for Wildlife and Fish: A Proceedings*. USDA Forest Service General Technical Report SO-65, pp. 6-11.
- Dissmeyer, G.E. and E. Frandsen. 1988. *The Economics of Silvicultural Best Management Practices*. American Water Resources Association, Bethesda, MD. pp. 77-86.
- Dissmeyer, G.E., and R. Miller. 1991. *A Status Report on the Implementation of the Silvicultural Nonpoint Source Program in the Southern States*.
- Dissmeyer, G.E. and R.F. Stump. 1978. *Predicted Erosion Rates for Forest Management Activities in the Southeast*. USDA Forest Service.
- Doolittle, G.B. 1990. The Use of Expert Assessment in Developing Management Plans for Environmentally Sensitive Wetlands: Updating A Case Study in Champion International's Western Florida Region. *Best Management Practices for Forested Wetlands: Concerns, Assessment, Regulation and Research*. NCASI Technical Bulletin No. 583, pp. 66-70.
- Douglass, J.E., and W.T. Swank. 1975. Effects of Management Practices on Water Quality and Quantity: Coweeta Hydrologic Laboratory, North Carolina. In: *Municipal Watershed Management Symposium Proceedings*. USDA Forestry Service. General Technical Report NE-13, pp. 1-13.
- Dubensky, M.M. 1991. Public comment information provided by the American Paper Institute and National Forest Products Association.
- Dunford, E.G. 1962. Logging Methods in Relation to Stream Flow and Erosion. In *Fifth World Forestry Congress 1960 Proceedings*, 3:1703-1708.
- Dykstra, D.P., and Froehlich, H.A. 1976a. Costs of Stream Protection During Timber Harvest. *Journal of Forestry*, 74(10):684-687.
- Dykstra, D.P., and H.A. Froehlich. 1976b. Stream protection: What does it cost? In *Loggers Handbook*, Pacific Logging Congress, Portland, OR.
- Dyrness, C.T. 1963. Effects of Burning on Soil. In *Symposium on Forest Watershed Management*, Society of American Foresters and Oregon State University, March 25-28, 1963, pp. 291-304.
- Dyrness, C.T. 1967. *Mass Soil Movements in the H.J. Andrews Experimental Forest*. USDA Forest Service, Pacific Northwest Forest and Range Experiment Station. Research Paper PNW-42.
- Dyrness, C.T. 1970. *Stabilization of Newly Constructed Road Backslopes by Mulch and Grass-Legume Treatments*. USDA Forest Service, Pacific Northwest Forest and Range Experiment Station. PNW-123.
- Ellefson, P.V., and P.D. Miles. 1984. Economic Implications of Managing Nonpoint Forest Sources of Water Pollutants: A Midwestern Perspective. In *Mountain Logging Symposium Proceedings*, June 5-7, 1984, West Virginia University, ed. P.A. Peters and J. Luchok, pp. 107-119.

- Ellefson, P.V., and R.E. Weible. 1980. Economic Impact of Prescribing Forest Practices to Improve Water Quality: A Minnesota Case Study Minnesota. *Forestry Research Notes*.
- Erman, D.C., J.D. Newbold, and K.B. Roby. 1977. *Evaluation of Streamside Buffer Strips for Protecting Aquatic Organisms*. California Water Resources Center, University of California, Davis, CA.
- Eschner, A.R., and J. Larmoyeux. 1963. Logging and Trout: Four Experimental Forest Practices and their Effect on Water Quality. *Progress in Fish Culture*, 25:59-67.
- Essig, D.A. 1991. *Implementation of Silvicultural Nonpoint Source Programs in the United States, Report of Survey Results*. National Association of State Foresters.
- Everst, F.H., and W.R. Meehan. 1981. Forest Management and Anadromous Fish Habitat Productivity. In *Transactions of the 46th North American Wildlife and Natural Resources Conference*, pp. 521-530. Wildlife Management Institute, Washington, DC.
- Feller, M.C. 1981. Effects of Clearcutting and Slash Burning on Stream Temperature in Southwestern British Columbia. *Water Resources Bulletin*, 17(5):863-866.
- Feller, M.C. 1989. Effects of Forest Herbicide Applications on Streamwater Chemistry in Southwestern British Columbia. *Water Resources Bulletin*, 25(3):607-616.
- Florida Department of Agriculture and Consumer Services, Division of Forestry and Florida Forestry Association. 1988. *Management Guidelines for Forested Wetlands in Florida*.
- Florida Department of Agriculture and Consumer Services, Division of Forestry. 1991. *Silviculture Best Management Practices*.
- Fraye, W.E., T.J. Monahan, D.C. Bowden, and F.A. Graybill. 1983. *Status and Trends of Wetlands and Deepwater Habitats in the Conterminous United States, 1950's to 1970's*. Colorado State University Department of Forest and Wood Sciences, Fort Collins, CO.
- Fredriksen, R.L., and R.N. Ross. 1974. Timber Production and Water Quality — Progress in Planning for the Bull Run, Portland Oregon's Municipal Watershed. In *Proceedings of the Society of American Foresters*, pp. 168-186.
- Fredriksen, R.L., D.G. Moore, and L.A. Norris. 1973. The Impact of Timber Harvest, Fertilization, and Herbicide Treatment on Streamwater Quality in Western Oregon and Washington. In *Forest Soils and Forest Land Management, Proceedings of the Fourth North American Forest Soils Conference*, ed. B. Bernier and C.H. Winget, pp. 283-313.
- Froehlich, H.A. 1973. Natural and man-caused slash in headwater streams. *Loggers Handbook*, Pacific Logging Congress, Vol. XXXIII.
- Furniss, M.J., T.D. Roelofs, and C.S. Yee. 1991. Road Construction and Maintenance. *Influences of Forest and Rangeland Management on Salmonid Fishes and Their Habitats*. American Fisheries Society Special Publication 19, pp. 297-324.
- Gardner, R.B. 1967. Major Environmental Factors That Affect the Location, Design, and Construction of Stabilized Forest Roads. *Loggers Handbook*, vol. 27. Pacific Logging Congress, Portland, OR.
- Georgia Forestry Association, Wetlands Committee. 1990. *Best Management Practices for Forested Wetlands in Georgia*.

- Georgia Forestry Commission. 1988. *Recommended Best Management Practices for Forestry in Georgia*.
- Gibson, H.E., and C.J. Biller. 1975. A Second Look at Cable Logging in the Appalachians. *Journal of Forestry*, 73(10):649-653.
- Golden, M.S., C.L. Tuttle, J.S. Kush, and J.M. Bradley. 1984. *Forestry Activities and Water Quality in Alabama: Effects, Recommended Practices, and an Erosion-Classified System*. Auburn University Agricultural Experiment Station, Bulletin 555.
- Hall, J.D., G.W. Brown, and R.L. Lantz. 1987. The Alsea Watershed Study - A Retrospective. In *Managing Oregon's Riparian Zone for Timber, Fish and Wildlife*, NCASI Technical Bulletin No. 514, pp. 35-40.
- Hartman, G., J.C. Scrivener, L.B. Holtby, and L. Powell. 1987. Some Effects of Different Streamside Treatments on Physical Conditions and Fish Population Processes in Carnation Creek, A Coastal Rain Forest Stream in British Columbia. In *Streamside Management: Forestry and Fishery Interactions*, ed. E.O. Salo and T.W. Cundy. College of Forest Resources, University of Washington, Seattle, WA, pp. 330-372.
- Hausman, R.F., and E.W. Pruett. 1978. *Permanent Logging Roads for Better Woodlot Management*. USDA Forest Service, State and Private Forestry, Eastern Region.
- Henly, R.K., and P.V. Ellefson. 1987. State-administered Forestry Programs: Current Status and Prospects for Expansion. *Renewable Resources Journal*, 5(4):19.
- Hetherington, E.D. 1985. Streamflow Nitrogen Loss Following Forest Fertilization in a Southern Vancouver Island Watershed. *Canadian Journal of Forestry Research*, 15(1):34-41.
- Hornbeck, J.W., and K.G. Reinhart. 1964. Water Quality and Soil Erosion as Affected by Logging in Steep Terrain. *Journal of Soil and Water Conservation*, 19(1):23-27.
- Hornbeck, J.W., C.W. Martin, and C.T. Smith. 1986. Protecting Forest Streams During Whole-Tree Harvesting. *Northern Journal of Applied Forestry*, 3:97-100.
- Huff, J.L., and E.L. Deal. 1982. *Forestry and Water Quality in North Carolina*. North Carolina Agricultural Extension Service, North Carolina State University.
- Hynson, J., P. Adamus, S. Tibbetts, and R. Darnell. 1982. *Handbook for Protection of Fish and Wildlife from Construction of Farm and Forest Roads*. U.S. Fish and Wildlife Service. FWS/OBS-82/18.
- Ice, G. 1985. The Status of Silvicultural Nonpoint Source Programs. In *Perspectives on Nonpoint Source Pollution*. U.S. Environmental Protection Agency, pp. 223-226.
- Illinois Department of Conservation. 1990. *Forestry Development Cost-Share Program*. Illinois Administrative Code, Title 17, Chapter I, subchapter d, Part 1536.
- King, J.G. 1984. *Ongoing Studies in Horse Creek on Water Quality and Water Yield*. NCASI Technical Bulletin 435, pp. 28-35.
- Kochenderfer, J.N. 1970. *Erosion Control on Logging Roads in the Appalachians*. USDA Forest Service, Northeastern Forest Experiment Station, Research Paper NE-158.
- Kochenderfer, J.N. and Helvey, J.D. 1984. Soil Losses from a "Minimum-Standard" Truck Road Constructed in the Appalachians. In *Mountain Logging Symposium Proceedings, June 5-7*, ed. P.A. Peters and J. Luckok, West Virginia University.

- Kochenderfer, J.N. and G.W. Wendel. 1980. *Costs and Environmental Impacts of Harvesting Timber in Appalachia with a Truck-mounted Crane*. USDA Forest Service Research Paper NE-456.
- Kochenderfer, J.N., G.W. Wendel, and H.C. Smith. 1984. *Cost of and Soil Loss on "Minimum-Standard" Forest Truck Roads Constructed in the Central Appalachians*. USDA Forest Service Northeastern Forest Experiment Station, Research Paper NE-544.
- Kuehn, M.H., and J. Cobourn. 1989. *Summary Report for the 1988 Cumulative Watershed Effects Analyses on the Eldorado National Forest - Final Draft*.
- Kundt, J.F., and T. Hall. 1988. *Streamside Forests: The Vital Beneficial Resource*. University of Maryland Cooperative Extension Service and U.S. Fish and Wildlife Service.
- Lantz, R.L. 1971. *Guidelines for Stream Protection in Logging Operations*. Oregon State Game Commission.
- Larse, R.W. 1971. Prevention and Control of Erosion and Stream Sedimentation from Forest Roads. In *Proceedings of the Symposium of Forest Land Uses and the Stream Environment*, pp. 76-83. Oregon State University.
- Lickwar, P.M. 1989. *Estimating the Costs of Water Quality Protection on Private Forestlands in the South*. Master's thesis submitted to the University of Georgia.
- Likens, G.E., F.H. Bormann, N.M. Johnson, D.W. Fisher, and R.S. Pierce. 1970. Effects of Forest Cutting and Herbicide Treatment on Nutrient Budgets in the Hubbard Brook Watershed-Ecosystem. *Ecological Monographs*, 40(1):23-47.
- Louisiana Forestry Association. 1988. *Recommended Forestry Best Management Practices for Louisiana*. Louisiana Department of Agriculture and Forestry.
- Lynch, J.A., E.S. Corbett, and K. Mussallem. 1985. Best Management Practices for Controlling Nonpoint-Source Pollution on Forested Watersheds. *Journal of Soil and Water Conservation*, 41(1):164-167.
- Lynch, J.A., and E.S. Corbett. 1990. Evaluation of Best Management Practices for Controlling Nonpoint Pollution from Silvicultural Operations. *Water Resources Bulletin*, 26(1):41-52.
- Mader, S.F., W.M. Aust, and R. Lea. 1989. Changes in Functional Values of a Forested Wetland Following Timber Harvesting Practices. In *Proceedings of the Symposium: The Forested Wetlands of the Southern United States, Orlando, Florida, July 12-14, 1988*. USDA Forest Service General Technical Report SE-50, pp. 149-154.
- Maine Forest Service, Department of Conservation. 1991. *Erosion and Sediment Control Handbook for Maine Timber Harvesting Operations: Best Management Practices*.
- Malueg, K.W., C.F. Powers, and D.F. Krawczyk. 1972. Effects of Aerial Forest Fertilization with Urea Pellets on Nitrogen Levels in a Mountain Stream. *Northwest Science*, 46:52-58.
- Maryland Department of the Environment. Undated. *Soil Erosion and Sediment Control Guidelines for Forest Harvest Operations in Maryland*.
- McClurkin, D.C., P.D. Duffy, and N.S. Nelson. 1987. Changes in Forest Floor and Water Quality Following Thinning and Clearcutting of 20-year-old Pine. *Journal of Environmental Quality*, 16(3):237-291.
- McMinn, J.W. 1984. Soil Disturbance by Fuelwood Harvesting with a Conventional Ground System and a Cable Miniyarder in Mountain Hardwood Stands. In *Mountain Logging Symposium Proceedings*, ed. P.A. Peters and J. Luchok, June 5-7, 1984. West Virginia University, pp. 93-98.

- Megahan, W.F. 1980. Nonpoint Source Pollution from Forestry Activities in the Western United States: Results of Recent Research and Research Needs. In *U.S. Forestry and Water Quality: What Course in the 80s?, Proceedings of the Water Pollution Control Federation Seminar, Richmond, VA, June 19, 1980*, pp. 92-151.
- Megahan, W.F. 1981. Effects of Silvicultural Practices on Erosion and Sedimentation in the Interior West—A Case for Sediment Budgeting. In *Interior West Watershed Management Symposium Proceedings*, ed. D.M Baumgartner. Washington State University, Cooperative Extension, pp. 169-182.
- Megahan, W.F. 1983. Appendix C: Guidelines for Reducing Negative Impacts of Logging. In: *Tropical Watersheds: Hydrologic and Soils Response to Major Uses or Conversions*, ed. L.S. Hamilton and P.N. King. Westview Press, Boulder, CO, pp. 143-154.
- Megahan, W.F. 1986. Recent Studies on Erosion and Its Control on Forest Lands in the United States. In: , pp. 178-189.
- Megahan, W.F. 1987. Effects of Forest Roads on Watershed Function in Mountainous Areas. In *Environmental Geotechnics and Problematic Soils and Rocks*, ed. Balasubramaniam et al. pp. 335-348.
- Mersereau, R.C., and C.T. Dyrness. 1972. Accelerated Mass Wasting after Logging and Slash Burning in Western Oregon. *Journal of Soil and Water Conservation*, 27:112-114.
- Miller, J.H., and D.L. Sirois. 1986. Soil Disturbance by Skyline Yarding vs. Skidding in a Loamy Hill Forest. *Soil Science Society of America Journal*, 50(6):1579-1583.
- Minnesota Department of Natural Resources, Division of Forestry. 1989. *Water Quality in Forest Management, "Best Management Practices in Minnesota."*
- Minnesota Department of Natural Resources, Division of Forestry. 1991. *Minnesota Forest Stewardship Program.*
- Mississippi Forestry Commission. 1989. *Mississippi's Best Management Practices Handbook.*
- Moore, D.G. 1975. Impact of Forest Fertilization on Water Quality in the Douglass Fir Region—A Summary of Monitoring Studies. In *Proceeding Forestry Issues in Urban America, New York, NY, September 22-26, 1974*. Society of American Foresters.
- Murphy, M.L., K.V. Koski, J. Heifetz, S.W. Johnson, D. Kirchhofer, and J.F. Thedinga. 1984. Role of Large Organic Debris as Winter Habitat for Juvenile Salmonids in Alaska Streams. In *Western Proceedings of the 64th Annual Conference of the Western Association of Fish and Wildlife Agencies, Victoria, British Columbia, July 16-19, 1984*, pp. 251-262.
- Narver, D.W. 1971. Effects of Logging Debris on Fish Production. In *Forest Land Uses and Stream Environment*, ed. J.T. Krygier and J.D. Hall, School of Forestry and Department of Fisheries and Wildlife, Oregon State University, October 19-21, pp. 100-111.
- Neary, D.G. 1985. Fate of Pesticides in Florida's Forests: An Overview of Potential Impacts in Water Quality. In *Proceedings Soil and Crop Science Society of Florida*, pp. 18-24.
- Neary, D.G., P.B. Bush, J.E. Douglass, and R.L. Todd. 1985. Picloram Movement in an Appalachian Hardwood Forest Watershed. *Journal of Environmental Quality*, 14(4):585-591.
- Neary, D.G., W.T. Swank, and H. Riekerk. 1989. An Overview of Nonpoint Source Pollution in the Southern United States. In *Proceedings of the Symposium: Forested Wetlands of the Southern United States, July 12-14, 1988, Orlando, FL*. USDA Forest Service. General Technical Report SE-50, pp. 1-7.

- Norris, L.A., and D.G. Moore. 1971. The Entry and Fate of Forest Chemicals in Streams. In *Forest Land Uses and Stream Environment - Symposium Proceedings*, ed. J.T. Krygier and J.D. Hall, Oregon State University, Corvallis, OR, pp. 138-158.
- Norris, L.A., H.W. Lorz, and S.V. Gregory. 1991. Forest Chemicals. *Influences of Forest and Rangeland Management on Salmonid Fishes and Their Habitats*. American Fisheries Society Special Publication 19, pp. 207-296.
- North Carolina Division of Forest Resources. 1989. *Forestry Best Management Practices Manual*. Department of Environment, Health and Natural Resources.
- Nutter, W.L., and J.W. Gaskin. 1989. Role of Streamside Management Zones in Controlling Discharges to Wetlands. In *Proceedings of the Symposium: The Forested Wetlands of the Southern United States, July, 12-14, 1988, Orlando, Florida*. USDA Forest Service. General Technical Report SE-50, pp. 81-84.
- Ohio Department of Natural Resources. *BMPs for Erosion Control on Logging Jobs*. Silvicultural Nonpoint Source Pollution Technical Advisory Committee.
- Olsen, E.D. 1987. A Case Study of the Economic Impact of Proposed Forest Practices Rules Regarding Stream Buffer Strips on Private Lands in the Oregon Coast Range. In *Managing Oregon's Riparian Zone for Timber, Fish and Wildlife*, NCASI Technical Bulletin No. 514, pp. 52-57.
- Ontario Ministry of Natural Resources. 1988. *Environmental Guidelines for Access Roads and Water Crossings*. Queen's Printer for Ontario, Ontario, Canada.
- Oregon Department of Forestry. 1979a. *Waterbars*. Forest Practices Notes No. 1. Oregon Department of Forestry, Forest Practices Section, Salem, OR.
- Oregon Department of Forestry. 1979b. *Reforestation*. Forest Practices Notes No. 2. Oregon Department of Forestry, Forest Practices Section, Salem, OR.
- Oregon Department of Forestry. 1981. *Road Maintenance*. Forest Practices Notes No. 4. Oregon Department of Forestry, Forest Practices Section, Salem, OR.
- Oregon Department of Forestry. 1982. *Ditch Relief Culverts*. Forest Practices Notes No. 5. Oregon Department of Forestry, Forest Practices Section, Salem, OR.
- Oregon Department of Forestry. 1991. *Forest Practices Rules, Eastern Oregon Region*. Oregon Department of Forestry, Forestry Practices Section, Salem, OR.
- Page, C.P., and A.W. Lindenmuth, Jr. 1971. Effects of Prescribed Fire on Vegetation and Sediment in Oak-Mountain Mahogany Chaparral. *Journal of Forestry*, 69:800-805.
- Pardo, R. 1980. What is Forestry's Contribution to Nonpoint Source Pollution? In *U.S. Forestry and Water Quality: What Course in the 80s? Proceedings of the Water Pollution Control Federation Seminar, Richmond, VA, June 19, 1980*, pp. 31-41.
- Patric, J.H. 1976. Soil Erosion in the Eastern Forest. *Journal of Forestry*, 74(10):671-677.
- Patric, J.H. 1980. Effects of Wood Products Harvest on Forest Soil and Water Relations. *Journal of Environmental Quality*, 9(1):73-80.

- Patric, J.H. 1984. Some Environmental Effects of Cable Logging in the Eastern Hardwoods. In *Mountain Logging Symposium Proceedings*, ed. P.A. Peters and J. Luchok, June 5-7, 1984, West Virginia University, pp. 99-106.
- Pennsylvania Bureau of Soil and Water Conservation. 1990. *Erosion and Sediment Pollution Control Program Manual*. Pennsylvania Department of Environmental Resources.
- Pope, P.E. 1978. *Forestry and Water Quality: Pollution Control Practices*. Forestry and Natural Resources, FNR 88, Purdue University Cooperative Extension Services.
- Rice, R.M., J.S. Rothacher, and W.F. Megahan. 1972. Erosional Consequences of Timber Harvesting: An Appraisal. In *Watersheds in Transition Symposium Proceedings*, AWRA, Urbana, IL, pp. 321-329.
- Richter, D.D., C.W. Ralston, and W.R. Harms. 1982. Prescribed Fire: Effects on Water Quality and Forest Nutrient Cycling (Hydraulic Systems, Pine Litter, USA). *Science*, 215:661-663.
- Riekerk, H. 1983. Environmental Impacts of Intensive Silviculture in Florida. In *I.U.F.R.O. Symposium on Forest Site and Continuous Productivity*. USDA Forest Service, Pacific Northwest Forest and Range Experiment Station. General Technical Report PNW-163, pp. 264-271.
- Riekerk, H. 1983. Impacts of Silviculture on Flatwoods Runoff, Water Quality, and Nutrient Budgets. *Water Resources Bulletin*, 19(1):73-80.
- Riekerk, H. 1985. Water Quality Effects of Pine Flatwoods Silviculture. *Journal of Soil and Water Conservation*, 40(3):306-309.
- Riekerk, H. 1989. Forest Fertilizer and Runoff-Water Quality. In *Soil and Crop Science Society of Florida Proceedings, September 20-22, 1988, Marco Island, FL*, Vol. 48, pp. 99-102.
- Riekerk, H., D.G. Neary, and W.J. Swank. 1989. The Magnitude of Upland Silviculture Nonpoint Source Pollution in the South. In *Proceedings of the Symposium: Forested Wetlands of the Southern United States, July 12-14, Orlando, FL*, pp. 8-18.
- Rothwell, R.L. 1978. *Watershed Management Guidelines for Logging and Road Construction in Alberta*. Canadian Forestry Service, Northern Forest Research Centre, Alberta, Canada. Information Report NOR-X-208.
- Rothwell, R.L. 1983. Erosion and Sediment Control at Road-Stream Crossings (Forestry). *The Forestry Chronicle*, 59(2):62-66.
- Rygh, J. 1990. *Fisher Creek Watershed Improvement Project Final Report*. Payette National Forest.
- Salazar, D.J. and F.W. Cabbage. 1990. Regulating Private Forestry in the West and South. *Journal of Forestry*, 88(1):14-19.
- Sidle, R.C. 1980. *Impacts of Forest Practices on Surface Erosion*. Pacific Northwest Extension Publication PNW-195, Oregon State Univ. Extension Service.
- Sidle, R.C. 1989. Cumulative Effects of Forest Practices on Erosion and Sedimentation. In *Forestry on the Frontier Proceedings of the 1989 Society of American Foresters, September 24-27, Spokane, WA*, pp. 108-112.
- Stednick, J.D., L.N. Tripp, and R.J. McDonald. 1982. Slash Burning Effects on Soil and Water Chemistry in Southeastern Alaska. *Journal of Soil and Water Conservation*, 37(2):126-128.

- Stone, E. 1973. *The Impact of Timber Harvest on Soils and Water*. Report of the President's Advisory Panel on Timber and the Environment, Arlington, VA, pp. 427-467.
- Swank, W.T., L.W. Swift, Jr., and J.E. Douglass. 1988. Streamflow Changes Associated with Forest Cutting, Species Conversions and Natural Disturbances. In *Forest Hydrology and Ecology at Coweeta*, Chapter 22, ed. W.T. Swank and D.A. Crossley, Jr., pp.297-312. Springer-Verlag, New York, NY.
- Swift, L.W., Jr. 1984a. Gravel and Grass Surfacing Reduces Soil Loss from Mountain Roads. *Forest Science*, 30(3):657-670.
- Swift, L.W., Jr. 1984b. Soil Losses from Roadbeds and Cut and Fill Slopes in the Southern Appalachian Mountains. *Southern Journal of Applied Forestry*, 8(4):209-215.
- Swift, L.W., Jr. 1985. Forest Road Design to Minimize Erosion in the Southern Appalachians. In *Forestry and Water Quality: A Mid-South Symposium, May 8-9, 1985, Little Rock, AR*, ed. B.G. Blackmon, pp. 141-151. University of Arkansas Cooperative Extension.
- Swift, L.W., Jr. 1986. Filter Strip Widths for Forest Roads in the Southern Appalachians. *Southern Journal of Applied Forestry*, 10(1):27-34.
- Swift, L.W., Jr. 1988. Forest Access Roads: Design, Maintenance, and Soil Loss. In *Forest Hydrology and Ecology at Coweeta*, Chapter 23, ed. W.T. Swank and D.A. Crossley, Jr., pp. 313-324. Springer-Verlag, New York, NY.
- Tennessee Department of Conservation, Division of Forestry. 1990. *Best Management Practices for Protection of the Forested Wetlands of Tennessee*.
- Texas Forestry Association. 1989. *Texas Best Management Practices for Silviculture*.
- Toliver, J.R., and B.D. Jackson. 1989. Recommended Silvicultural Practices in Southern Wetland Forests. In *Proceedings of the Symposium: The Forested Wetlands of the Southern United States, Orlando, Florida, July 12-14, 1988*. USDA Forest Service General Technical Report SE-50, pp. 72-77.
- Trimble, G.R., and S. Weitzman. 1953. Soil Erosion on Logging Roads. *Soil Science Society of America Proceedings*, 17:152-154.
- USDA, Forest Service. 1987. *Soil and Water Resource Management: A Cost or a Benefit? Approaches to Watershed Economics through Example*.
- USEPA. 1984. *Report to Congress: Nonpoint Source Pollution in the U.S.*, U.S. Environmental Protection Agency, Office of Water Program Operations, Washington, DC.
- USEPA. 1991. *Pesticides and Groundwater Strategy*. U.S. Environmental Protection Agency, Office of Prevention, Pesticides, and Toxic Substances, Washington, DC.
- USEPA. 1992a. *Managing Nonpoint Source Pollution, Final Report to Congress on Section 319 of the Clean Water Act (1989)*. U.S. Environmental Protection Agency, Office of Water, Washington, DC. EPA-506/9-90.
- USEPA. 1992b. *National Water Quality Inventory: 1990 Report to Congress*. U.S. Environmental Protection Agency, Office of Water, Washington, DC.
- Vermont Department of Forests, Parks, and Recreation. 1987. *Acceptable Management Practices for Maintaining Water Quality on Logging Jobs in Vermont*.

- Virginia Department of Forestry. *Forestry Best Management Practices for Water Quality in Virginia*.
- Washington State Forest Practices Board. 1988. *Washington Forest Practices Rules and Regulations. Washington Annotated Code, Title 222; Forest Practices Board Manual, and Forest Practices Act*.
- Weitzman, S., and G.R. Trimble, Jr. 1952. Skid-road Erosion Can Be Reduced. *Journal of Soil and Water Conservation*, 7:122-124.
- Whitman, R. 1989. Clean Water or Multiple Use? Best Management Practices for Water Quality Control in the National Forests. *Ecology Law Quarterly*, 16:909-966.
- Willingham, P.W. 1989. Wetlands Harvesting Scott Paper Company. *Proceedings of the Symposium: The Forested Wetlands of the Southern United States, Orlando, Florida, July 12-14, 1988*. USDA Forest Service General Technical Report SE-50, pp. 63-66.
- Wisconsin Department of Natural Resources. 1989. *Forest Practice Guidelines for Wisconsin*. Bureau of Forestry, Madison, WI. PUBL-FR-064-89.
- Yee, C.S., and T.D. Roelofs. 1980. *Planning Forest Roads to Protect Salmonid Habitat*. USDA Forest Service. General Technical Report PNW-109.
- Yoho, N.S. 1980. Forest Management and Sediment Production in the South—A Review. *Southern Journal of Applied Forestry*, 4(1):27-36.



Appendix 3A

Examples of State Processes Useful for Ensuring Implementation of Management Measures

3A-1: Examples from Florida



SRWMD PERMIT NUMBER _____ APPLICATION FOR AGRICULTURE OR FORESTRY MANAGEMENT GENERAL SURFACEWATER MANAGEMENT PERMIT FORM 40B-4-1

SUWANNEE RIVER WATER DISTRICT ROUTE 3, BOX 64 LIVE OAK, FLORIDA 32060 TELEPHONE (904) 362-1001

Landowner/Applicant: _____

Address: _____ Street - Route - Box City State Zip Code

Person Responsible: _____

Phone: _____ Beginning Date: _____

Project Location: _____ County Location Sketch: _____

Township Range Section

Parcel ID Number (from County records)

Project Area: _____ Acres owned or in management block

_____ Acres in project area (aerial photograph copy with project area outlined is suggested.)

Wetlands Area: _____ Wetland acres in project area

_____ Wetland acres affected by the work

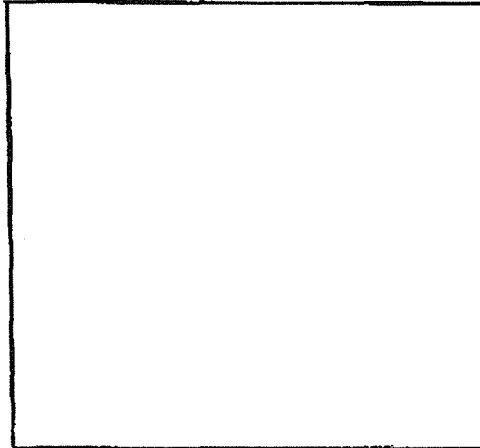

Description of the proposed work to include sizes and dimensions: _____

THE GENERAL SURFACEWATER MANAGEMENT PERMIT AUTHORIZED BY SS.40B-4.2010(1), FLORIDA ADMINISTRATIVE CODE (F.A.C.), REQUIRES PERMITTEES TO COMPLY WITH BEST MANAGEMENT AND ACCEPTED CONSERVATION PRACTICES. ADDITIONAL LIMITATIONS AND/OR STANDARDS ARE CONTAINED IN SS.40B-4.2010(1)(C)1. THROUGH 6. A COPY OF CHAPTER 40B-4, F.A.C., AND BEST MANAGEMENT PRACTICES MANUALS ARE AVAILABLE AT NO CHARGE FROM THE DISTRICT, OR QUESTIONS MAY BE DIRECTED TO THE SUWANNEE RIVER WATER MANAGEMENT DISTRICT AT 904/362-1001 OR 1-800-342-1002. A DISTRICT PERMIT DOES NOT RELIEVE A PERMITTEE FROM OBTAINING APPROVALS THAT MAY BE REQUIRED BY ANY UNIT OF LOCAL, STATE, OR FEDERAL GOVERNMENT.

THIS APPLICATION IS NOT TO BE USED FOR SUBDIVISIONS, COMMERCIAL PROJECTS, OR ANY OTHER NON-AGRICULTURAL OR FORESTRY WORK.

Landowner/Applicant's Signature Title Date

SRWMD Staff Signature Title Date Approved

SRWMD Form 40B-4-1 (REV. 12/90)

White-SRWMD/Yellow-Permittee

Authorization No. _____

NORTHWEST FLORIDA WATER MANAGEMENT DISTRICT
FORESTRY AUTHORIZATION NOTIFICATION FORM

Instructions:

1. Deliver or mail to the appropriate District Office identified on the attached sheet at least two (2) working days before commencing activity.
2. Emergency authorizations may be requested by calling the appropriate District Office.
3. See attached sheet for list of qualifying projects, limiting conditions, and District Offices.

Application is for: Construction Replacement Maintenance

Owner's Name: _____ Phone: _____

Address: _____

City: _____ State: _____ Zip: _____

Agent's Name: _____ Phone: _____

Address: _____

City: _____ State: _____ Zip: _____

Only the minor works listed in Section 40A-44.052(1), F.A.C. (see attached sheet), may qualify for an authorization. After reviewing the attached list, which letter identifies the minor work you propose? Please circle the appropriate one(s):

A B C D E F

Detailed description of the proposed work, include water quality protection and site stabilization methods: _____

Starting Date: _____

Location of Proposed Work:

County: _____

Section: _____

Township: _____

Range: _____

Water Body Affected: _____

Location Sketch

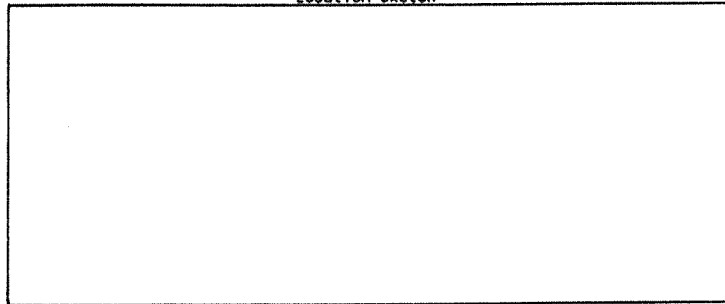

A copy of Chapter 40A-44, F.A.C., is available at any District office. A District authorization does not relieve a permittee from obtaining the necessary approvals of any local, state, or federal government.

I have read and will comply with the requirements of Section 40A-44.052, F.A.C. I understand that this Forestry Authorization Notice is available only under limited circumstances as set forth in Section 40A-44.052, F.A.C., and that permittees are required to comply with all limiting conditions listed in Section 40A-44.052, F.A.C.

Signature of: (Circle one) _____
Owner Agent

Printed Name _____

Date _____

* Signing by someone other than the owner is also certification that the person is authorized to act as the owner's agent.

NWFWMD Form A44-F
40A-44.052(2)(a), F.A.C.
Effective 7-1-92

White - District Copy, Yellow - Applicant's Copy

3A-2: Examples from Oregon

SIDE ONE

NOTIFICATION OF OPERATION / APPLICATION FOR PERMITS STATE OF OREGON DEPARTMENT OF FORESTRY DEPARTMENT OF REVENUE		NOTIFICATION NUMBER: _____	
1 County (Enter only one): _____		Date Received: _____	
2	Check Appropriate Boxes (2A, 2B, 2C, or 2D):	Time Received: _____	
	<input type="checkbox"/> 2A NOTICE TO THE STATE FORESTER THAT OPERATION WILL BE CONDUCTED ON LANDS DESCRIBED ON REVERSE (ORS 527.670)	District: _____	
	<input type="checkbox"/> 2B APPLICATION FOR PERMIT TO OPERATE POWER DRIVEN MACHINERY (ORS 477.625) Expires at end of calendar year.	Office: _____	
	<input type="checkbox"/> 2C APPLICATION FOR PERMIT TO CLEAR RIGHTS-OF-WAY (ORS 477.685)		
	<input type="checkbox"/> 2D NOTICE TO THE STATE FORESTER AND THE DEPARTMENT OF REVENUE OF THE INTENT TO HARVEST TIMBER (ORS 321.550)		
3	Person to be contacted in case of Fire Emergency (Designated Representative) Phone No PLEASE PRINT!	APPLICANT REMARKS:	
CHECK ONE BOX IN THE FAR LEFT COLUMN TO INDICATE WHO FILLED OUT THE APPLICATION.			
<input type="checkbox"/> 4 Operator Information	Name/Title		
	Company Name		
	Mailing Address - Street		
	City, State and Zip Code Phone No.		
<input type="checkbox"/> 5 Landowner Information	Name/Title		RC:
	Company Name		EG:
	Mailing Address - Street	S:	
	City, State and Zip Code Phone No.		
<input type="checkbox"/> 6 Timberowner and Harvest Tax Payer	Name/Title		
	Company Name		
	Mailing Address - Street		
	City, State and Zip Code Phone No.		
	Timberowner Employer Identification Number or Social Security Number		
<input type="checkbox"/> 7 Timber Sale Name and/or No.			
<input type="checkbox"/> 8 WESTERN OREGON PRIVATE LAND ONLY Is any timber being harvested certified under the Western Oregon Small Tract Optional Tax (WOSTOT) program? None Part All		WOSTOT Certificate Number	

FORM 529-6-2 1/02a (Rev. 11/81)

SIDE TWO

9 ACTIVITY CODES								10 LOCATION OF OPERATION																11 a	11 b	12 WEST	13 SITE CONDITIONS				REGULATED USE AREA									
FPF No (s)	Fire FPA	Unit Number	Activity Codes	Methods Used	Quantity (by unit)		Gov't Lot Numbers	N				W				S				S E C	T W P	R G E	ACTIVITY STARTING DATE	ACTIVITY ESTIMATED ENDING DATE	OREGON SEVERANCE TAX UNIT NUMBER	D100	D1	D2	D3											
					Acres	Feet		ne	nw	sw	so	ne	nw	sw	so	ne	nw	sw	so							ne	nw	sw	so	D100	D1	D2	D3	S1	S2	S3	DWS	WS	SW	UGB

14. If the applicant wants a waiver of the 15 day waiting period, check the box:

15 a. Print name of applicant here _____

15 b. I (applicant) certify that all information I have provided is true and correct. (Signature/Date) _____

16 ATTACH MAP AND/OR AERIAL PHOTOS!

Subscriber:	WRITTEN PLANS AND PRIOR APPROVALS:	Names of Protected Resources:	Comments
Subscriber:			
Subscriber:			
Subscriber:			
W. R. Subscriber:			
W. R. Subscriber:			

15 day waiting period waived by: _____ Date: _____

**INSTRUCTIONS FOR FILLING OUT
"NOTIFICATION OF OPERATION / APPLICATION FOR PERMITS"**

The instructions are numbered to match the numbered form areas. Please print or type the information on the form. Do not fill out any space shaded gray. File notice with the State Forester at least 15 days prior to the date you would like to start operating. A notification is not considered accepted until it is received by the appropriate office. Mail or deliver the form to one of the following offices:

Office Address	Phone Number	Office Address	Phone Number
ASTORIA: Rt. 1, Box 950, 97103	325-5451	MOLALLA: 14995 S. Hwy. 211, 97038	829-2216
BAKER: Rt. 1, Box 211, 97814	523-5831	MONUMENT: P.O. Box 386, 97864 (May Street)	934-2300
CENTRAL POINT: 5286 Table Rock Road, 97502	664-3328	PENDLETON: 1055 Airport Rd., 97801	278-3491
COLUMBIA CITY: 405 E. St., 97018	397-2636	PHILOMATH: 24533 Alsea Hwy., 97370	929-3266
COOS BAY: 300 Fifth St., Bay Park, 97420	267-3161	PRINEVILLE: 220710 Ochoco Hwy., 97754	447-5658
DALLAS: 825 Oak Villa Rd. 97338	623-8148	ROSEBURG: 1758 N.E. Airport Road, 97470-1499	440-3412
FOREST GROVE: 801 Gales Cr. Rd. 97116-1199	357-2191	SISTERS: P.O. Box 190, 97759 (221 SW Washington)	549-2731
FOSSIL: Star Route, 97830	763-2575	SPRINGFIELD: 3150 E. Main St., 97478	726-3588
GOLD BEACH: P.O. Box 603, 97444	247-6565	SWEET HOME: 4690 Hwy. 20, 97386	367-6108
GRANTS PASS: 5375 Monument Dr., 97526	474-3152	THE DALLES: 3701 W. 13th St., 97058	296-4626
JOHN DAY: P.O. Box 546, 97845 (400 NW 9th)	575-1139	TILLAMOOK: 4907 E. Third St., 97141-2999	842-2545
KLAMATH FALLS: 3400 Greensprings Dr., 97601	883-5681	TOLEDO: 763 N.W. Forestry Rd., 97391	336-2273
LA GRANDE: 611 20th St., 97850	963-3168	VENETA: P.O. Box 157, 97487	935-2283
LAKEVIEW: 2290 N. 4th St., 97630	947-3311	WALLOWA: Rt. 1, Box 80, 97885	886-2881
MEHAMA: 22965 N. Fork Rd. S.E., Lyons 97358 859-2151			

SIDE ONE - Notification of Operation/Application for Permits

1. "County (Enter only one)". Fill in the county where the operation will take place. If an operation spans two or more counties, file a separate notification for each county.

An operation can be any combination of the following activities: harvest of forest crops; road construction or reconstruction; site preparation; chemical application; clearing for land use change; treatment of slashing; pre-commercial thinning; or other activities which require separate explanation.

2. "Check Appropriate Boxes (2A, 2B, 2C, or 2D)" next to the notice you are giving and/or the permit(s) you need.

3. "Person to be contacted in case of Fire Emergency (Designated Representative). Phone No." Print the name and telephone number of the person to contact in case a fire starts on this operation. This person should know what resources you have available to fight the fire, and have the authority to commit those resources in case of a fire.

"Check one box in the left column to indicate who filled out the application."

4. "Operator Information" 5. "Landowner Information" 6. "Timberowner and Harvest Tax Payer." You must fill in either a person's or a company's name, address and phone number. Fill in EITHER the timberowner's Employer Identification number or the timberowner's social security number, not both. The person who owns timber at the time of severance from the stump (harvest) is the timberowner, and is responsible for paying the harvest tax.

7. "Timber Sale Name and/or No." Fill in the sale name and/or number. This information is required for all state and federal timber sales and is optional for private land timber sales.

8. "Western Oregon Private Land Only!" **If the timber to be harvested is from public land, do not fill out this portion!** If it is from private land, check with the landowner to see whether the timber has been certified under the Western Oregon Small Tract Optional Tax (WOSTOT) law. Timber removed from land certified under WOSTOT is normally exempt from the Western Oregon Severance Tax. If you have checked "Part" or "All", please list the certificate number in the WOSTOT Certificate Number box.

SIDE TWO - Site Information

9. "Activity Codes". There are six columns here. You assign a one- or two-digit unit number, beginning with 1 and going sequentially up to 99. Or, if there is a unit number associated with a state or federal timber sale, use that number in the unit column. A unit can be:

- an operating area with a state or federal sale unit number; or
- a single operating area within a continuous boundary; or
- an operating area with a separate harvest tax number; or
- a separate area within your total operation area on which you plan to conduct a single type of activity (for example, 30 acres of clear cut only).

3A-3: Examples from New Hampshire



STATE OF NEW HAMPSHIRE
Notice of Intent to Cut Wood or Timber
 (RSA 79:10)
 TAX YEAR APRIL 1, 1992 TO MARCH 31, 1993
 SEE INSTRUCTIONS FOR FILLING OUT THIS FORM ON REVERSE

PA-7
1992 - 1993
 Operation No.
DRA USE ONLY

PLEASE TYPE OR PRINT

1. To Selectmen/Assessors
 Town/City of _____ N.H.
2. Name & Tax Map # by which lot is commonly known.

3. Is this Intent an: Original Supplemental
 Orig. Oper. # _____
4. Name of road from which accessible: _____
5. Number of acres to be cut: _____
6. Type of ownership (check only one):
 - a. Owner of land and stumpage
 - b. Owner of stumpage only
 - c. Right of possession with authority to cut
 (including public lands)
7. Is any of the wood or timber cut for own use?
 (See Item #11) _____
8. If required, has a wetland notification or application been filed: YES
9. I/we hereby assume responsibility for any yield tax which may be assessed. (If Corporation, An Officer Must Sign)
 A
 SIGNATURE OF OWNER(S) _____ DATE _____
 B
 SIGNATURE _____
 PRINT OWNER(S) NAME CLEARLY _____
 MAILING ADDRESS _____
 TOWN/CITY _____ ZIP CODE _____
 Corp. _____
 Tel. No. _____
 Federal Identification No. or Social Security No. of Landowner

CHECK ONE: Corporation } Landowner
 Proprietorship }
 Partnership }

10. DESCRIPTION OF WOOD OR TIMBER TO BE CUT

Species	Estimated Amount To Be Cut
White Pine	BF
Hemlock	"
Red Pine	"
Spruce & Fir	"
Hard Maple	"
White Birch	"
Yellow Birch	"
Oak	"
Ash	"
Beech & Soft Maple	"
Pallet or Tie Logs	"
Others (Specify)	
Pulpwood:	Tons or Cords
Spruce & Fir	
Hardwood & Aspen	
Pine	
Hemlock	
Total Tree Chips	
Miscellaneous:	
Birch Bolts	Cords
Cordwood & Fuelwood	

11. AMOUNT OF WOOD OR TIMBER FOR PERSONAL USE

12. PLEASE SIGN THE FOLLOWING:
 I, _____ (SIGNATURE OF LOGGER, FORELSTER, RESPONSIBLE FOR OPERATION) (DATE) _____
 _____ (PRINT LOGGER, FORESTERS NAME)
 _____ MAILING ADDRESS _____

HAVE BECOME FAMILIAR WITH RSA 485-A, RSA 224:44A, 224:44B, 482-A AND RELATED RULES, AND HEREBY AGREE TO ABIDE BY APPROPRIATE, BEST MANAGEMENT PRACTICES TO INCLUDE ALL STATE LAWS PERTAINING TO LOGGING OPERATIONS.

13. CERTIFICATE/REPORT TO BE SENT TO LANDOWNER
 LOGGER/FORESTER

SPACE BELOW FOR ASSESSING OFFICIALS ONLY

Amount of Security Required and Posted: \$ _____ Type of Security Posted (Bond, Certified Check, etc.) _____
 _____ (Selectmen/Assessors)
 _____ of _____ Date _____

