

Volume II: Chapter 16

Methods for Estimating Air Emissions from Chemical Manufacturing Facilities

August 2007

Final



Prepared for
Emission Inventory Improvement Program

Prepared by
Mitchell Scientific, Inc.
Westfield, NJ

RTI International
Research Triangle Park, NC

Disclaimer

As the Environmental Protection Agency has indicated in Emission Inventory Improvement Program (EIIP) documents, the choice of methods to be used to estimate emissions depends on how the estimates will be used and the degree of accuracy required. Methods using site-specific data are preferred over other methods. These documents are non-binding guidance and not rules. EPA, the States, and others retain the discretion to employ or to require other approaches that meet the requirements of the applicable statutory or regulatory requirements in individual circumstances.

Table of Contents

1.0	Introduction.....	16.1-1
2.0	Source Category Description	16.2-1
2.1	Process Description	16.2-1
2.2	Emission Sources	16.2-1
2.2.1	Process Operations	16.2-2
2.2.1.1	Material Charging Emissions	16.2-2
2.2.1.2	Emissions from Process Heating.....	16.2-2
2.2.1.3	Emissions from Process Depressurization	16.2-2
2.2.1.4	Emissions from Gas Evolution Processes	16.2-2
2.2.1.5	Emissions from Gas Sweep and Purge Operations	16.2-2
2.2.1.6	Surface Evaporation	16.2-3
2.2.2	Miscellaneous Operations	16.2-3
2.2.2.1	Solvent Reclamation	16.2-3
2.2.2.2	Cleaning	16.2-3
2.2.3	Wastewater Treatment.....	16.2-3
2.2.4	Storage Tanks.....	16.2-3
2.2.5	Equipment Leaks.....	16.2-3
2.2.6	Spills.....	16.2-4
2.3	Process Design and Operating Factors Influencing Emissions	16.2-4
2.3.1	VOC Control Systems.....	16.2-4
2.3.2	PM/PM ₁₀ Control Systems	16.2-6
3.0	Basic Air Emission Models.....	16.3-1
3.1	Vessel Filling.....	16.3-1
3.1.1	Charging to an Empty Vessel.....	16.3-1
3.1.2	Charging to a Partially Filled Vessel with Miscible Contents	16.3-5
3.1.2.1	Subsurface Addition.....	16.3-6
3.1.2.2	Above Surface Addition.....	16.3-8
3.1.2.3	Addition of Immiscible Liquids	16.3-11
3.2	Purge/Gas Sweep Models.....	16.3-12
3.2.1	Purge or Gas Sweep – Empty Vessel Purge.....	16.3-12
3.2.2	Purge or Gas Sweep – Partially Filled Vessel.....	16.3-14
3.3	Vacuum Operations	16.3-17
3.4	Gas Evolution.....	16.3-20
3.5	Depressurization.....	16.3-23
3.6	Heating	16.3-26
3.7	Evaporation Models	16.3-31
3.7.1	Evaporation from an Open Top Vessel or a Spill.....	16.3-31
3.8	Emission Model for Liquid Material Storage.....	16.3-33
3.9	Emission Model for Wastewater Treatment.....	16.3-33
3.10	Using Sampling and Test Data to Validate Emission Studies.....	16.3-33
3.10.1	Correlating Standard Emission Models to Test Results	16.3-35

3.11	Emission Calculations Using Material Balance	16.3-38
3.12	Emission Calculations Using Emission Factors	16.3-38
4.0	Single Stage Vent Devices: Condensers, Vacuum Pumps, and Vacuum Steam Jets	16.4-1
4.1	General Calculation Considerations	16.4-1
4.1.1	Material Balance Considerations for the Vent Device	16.4-1
4.1.2	Equilibrium Relationships Between the Exit Liquid and Vapor Streams	16.4-2
4.1.3	Checking to See If Condensation Takes Place in the Vent Device	16.4-2
4.1.4	General Calculation Approach for Solving Single Stage Vent Device Problems	16.4-3
4.1.5	Partial Condensers	16.4-3
4.1.6	Total Condensers	16.4-4
4.1.7	Vent Condensers	16.4-4
4.1.8	Liquid Ring Vacuum Pumps	16.4-4
4.1.9	Vacuum Steam Jets	16.4-5
4.2	Illustrations	16.4-5
4.2.1	Condensers with One Condensable Component	16.4-5
4.2.2	Partial Condensers	16.4-11
4.2.3	Vent Condensers with Single-Phase Condensate	16.4-15
4.2.3.1	Option 1 – Modified Rachford-Rice Method	16.4-15
4.2.3.2	Option 2 – Partial Pressure Correction Method	16.4-21
4.2.3.3	Option 3 – Material Balance Correction Method	16.4-28
4.2.3.4	Non-ideal Liquid	16.4-34
4.2.4	Vent Condenser with Two Phase Condensate	16.4-40
4.2.5	Liquid-Ring Vacuum Pump	16.4-46
4.2.6	Vacuum Steam Jets	16.4-50
5.0	Basic Process Operations	16.5-1
5.1	Emission Calculations from Solvent Reclamation Systems	16.5-1
5.1.1	Emissions from Charging the Distillation Vessel with Cold Solvent for Recovery	16.5-1
5.1.2	Heating the Solvent for Distillation	16.5-2
5.1.3	Receiving the Solvent from Distillation	16.5-2
5.1.4	Drumming the Purified Toluene	16.5-3
5.1.5	Solvent Emissions from the Overall Toluene Recovery Process	16.5-3
5.2	Filtration Operations	16.5-3
5.3	Centrifuge Operations	16.5-4
5.4	Vacuum Dryer Model	16.5-6
5.4.1	Information Needed to Model a Vacuum Tray Drying Operation	16.5-6
5.4.1.1	Placing the material to be dried into the vacuum oven	16.5-6
5.4.1.2	Depressurization Step	16.5-7
5.4.1.3	Heating Step	16.5-7
5.4.1.4	Distillation Step	16.5-7
6.0	Physical Property Relationships	16.6-1
6.1	Basic Physical Properties Relationships	16.6-1
6.1.1	Unit Conversations	16.6-1
6.2	Basic Physical Property Relationships	16.6-1

6.2.1	Ideal Gas Law.....	16.6-1
6.2.2	Dalton’s Law	16.6-2
6.2.3	Mole Fraction in a Liquid.....	16.6-3
6.3	Pure Component Vapor Pressure.....	16.6-4
6.3.1	Clapeyron Vapor Pressure Equation	16.6-4
6.3.2	Antoine Equation.....	16.6-6
6.3.3	Other Vapor-Pressure Equation Forms	16.6-6
6.4	Component Vapor Pressure over Solutions.....	16.6-7
6.4.1	Equilibrium Conditions (Ideal) and Raoult’s Law	16.6-7
6.4.1.1	Using Raoult’s Law to determine molar concentration.....	16.6-9
6.4.2	Non-Ideal Equilibrium Conditions and Activity Coefficients.....	16.6-10
7.0	References.....	16.7-1

Table of Illustrations

3-1	Charging a pure solvent to an empty vessel	16.3-2
3-2	Charging a solvent mixture to an empty vessel	16.3-3
3-3	Charging a mixture to a partially filled vessel (subsurface addition).....	16.3-6
3-4	Charging a mixture to a partially filled vessel (above surface addition).....	16.3-8
3-5	Charging a mixture to a partially filled vessel (immiscible liquids).....	16.3-11
3-6	Purging an empty vessel or reactor containing solvent vapors.....	16.3-13
3-7	Gas sweep with a vessel containing with a single volatile solvent.....	16.3-16
3-8	Gas sweep with a vessel containing with a volatile solvent mixture.....	16.3-16
3-9	Vacuum operation with vessel filling.....	16.3-18
3-10	Vacuum operation without vessel filling.....	16.3-19
3-11	Reaction involving a gas evolution of one component.....	16.3-21
3-12	Reaction involving gas evolution of two components.....	16.3-21
3-13	Reaction involving multicomponent gas evolution and nitrogen purge.....	16.3-22
3-14	Vessel depressurization involving one volatile component.....	16.3-24
3-16	Heatup losses from a vessel containing a single volatile component.....	16.3-27
3-17	Heatup losses from a vessel containing a volatile mixture.....	16.3-28
3-18	Heatup losses from a vessel with a volatile mixture and nitrogen sweep.....	16.3-29
3-19	Evaporation from a vessel with an open top.....	16.3-32
3-20	Evaporation losses from a spill.....	16.3-32
3-21	Using emission measurements to represent production operations.....	16.3-34
3-22	Using material balance to estimate emissions from operations.....	16.3-38
4-1	Condenser with solvent vapor heptane and nitrogen.....	16.4-6
4-2	Condenser with toluene solvent vapor and nitrogen at vacuum conditions	16.4-8
4-3	Condenser with toluene vapor and nitrogen at atmospheric pressure	16.4-9
4-4	Rachford-Rice Method	16.4-12
4-5	Modified Rachford-Rice Method for Vent Condenser.....	16.4-17
4-6	Partial Pressure Correction Method for Vent Condenser	16.4-23
4-7	Material Balance Correction Method for Vent Condenser.....	16.4-31
4-8	Vent condenser with azeotrope, material balance correction method.....	16.4-34
4-9	Vent condenser with two phase condensate	16.4-40
4-10	Liquid-Ring Vacuum Pump with multi-component process stream.....	16.4-47
4-11	Vacuum steam jet – material balance correction method.....	16.4-50
5-1	Estimating emissions from a batch distillation operation.....	16.5-1
6-1	Calculating the moles of gas from volume, temperature, and pressure.....	16.6-2
6-2	Calculating molar quantities for gas mixtures.....	16.6-3
6-3	Calculating mole fractions for liquid mixtures.....	16.6-4
6-4	Estimating Clapeyron vapor pressure model coefficients.....	16.6-5
6-5	Calculating pure component vapor pressures from the Antoine model.....	16.6-6
6-6	Calculating vapor pressures using the AIChE DIPPR database model.....	16.6-7
6-7	Estimating component vapor pressures using Raoult’s Law.....	16.6-8
6-8	Estimating liquid composition based on vapor pressure measurements.....	16.6-9
6-9	Determining the molar composition of a liquid from vapor pressure data.....	16.6-9
6-10	Estimating activity coefficients from solution measurements.....	16.6-11
6-11	Estimating activity coefficients from azeotropic mixtures.....	16.6-11
6-12	Calculating vapor compositions using activity coefficients.....	16.6-12

List of Figures

Figure	Page
3-1 Saturation Level (S) Plotted as a Function of Exit Vent Gas Flow Rate.....	16.3-37
3-2 Toluene Emission Rate Plotted as a Function of Exit Gas Sweep Rate and Saturation Level.....	16.3-37
4-1 Diagrams of single stage vent devices.....	16.4-1
4-2 Generalized Rachford-Rice equation.....	16.4-11
4-3 Rachford-Rice Plot showing solution at $V/F = 0.236044$	16.4-14
4-4 Rachford-Rice Plot showing solution at $V/F = 0.90076$	16.4-19
4-5 Activity coefficients calculated for ethyl acetate and ethanol from the van Laar equation for the complete composition range.	16.4-36
4-6 Component vapor pressures calculated for ethyl acetate and ethanol based on liquid composition, activity coefficients, and pure component vapor pressures.	16.4-36
4-7 Ethyl acetate vapor composition plotted as a function of ethyl acetate composition in the liquid.....	16.4-37
5-1 Example filtration equipment arrangement.	16.5-4
5-2 Typical centrifuge equipment arrangement.	16.5-5
5-3 Diagram of a typical vacuum tray dryer system.....	16.5-6

List of Tables

Table	Page
3-1	Calculated Values for Use in Eq. 3-14 16.3-17
3-2	Iterative Trial and Error Results for Si using Eq. 3-14..... 16.3-17
3-3	Calculated Emission Rates 16.3-17
3-4	Partial Pressure Calculates for 20°C and 70°C..... 16.3-28
3-5	Final Calculated Results for This Problem..... 16.3-29
4-1	Inlet Feed Stream Analysis..... 16.4-13
4-2	Iteration Results for Illustration 4-4 16.4-14
4-3	Product Outlet Stream Analysis 16.4-15
4-4	Analysis of the Condenser Inlet Feed Stream..... 16.4-17
4-5	Check to See If Condensation Will Take Place at 2°C..... 16.4-18
4-6	Preparation for Applying the Modified Rachford-Rice Method 16.4-18
4-7	Iteration results for Illustration 4-5..... 16.4-20
4-8	Product Outlet Stream Analysis (mole fractions and rates in lb-moles)..... 16.4-21
4-9	Produce Streams Analysis 16.4-21
4-10	Analysis of the Condenser Inlet Feed Stream..... 16.4-23
4-11	Initial Estimate of Condensate..... 16.4-24
4-12	Convergence Determination 16.4-27
4-13	Material Balance for Condenser 16.4-28
4-14	Analysis of the Condenser Inlet Feed Stream..... 16.4-31
4-15	Initial Estimate of Condensate..... 16.4-32
4-16	Convergence Determination 16.4-33
4-17	Material Balance for Condenser 16.4-33
4-18	Condenser Inlet Stream Analysis for 1.0 hour of Operation 16.4-35
4-19	Calculated Mole Fractions for Only the Condensable Portion of the Inlet Process Vapor Stream..... 16.4-37
4-20	Condensate Feasibility Analysis..... 16.4-38
4-21	Iterative Solution to Determine Condensate Composition 16.4-39
4-22	Condenser Material Balance at Completion of Iterations..... 16.4-39
4-23	Exit Vent Stream Analysis Table 16.4-40
4-24	Inlet Stream Analysis over 1.0 Hour 16.4-40
4-25	Liquid Phase Solubility Data for 20°C..... 16.4-41
4-26	Equilibrium Mole Fraction Concentrations 16.4-42
4-27	Estimated Activity Coefficients..... 16.4-42
4-28	Aqueous Phase Condensate Feasibility Analysis 16.4-43
4-29	Non-Aqueous Phase Condensate Feasibility Analysis 16.4-44
4-30	Composition and Vapor Pressure Analysis of the Two Phase Condensate 16.4-44
4-31	Exit Liquid Stream Analysis..... 16.4-46
4-32	Condenser Material Balance at Completion of Iterations..... 16.4-46
4-33	Exit Vent Stream Analysis Table 16.4-46
4-34	Analysis of the Inlet Stream to the Liquid-Ring Vacuum Pump..... 16.4-47
4-35	Analysis of the Inlet Stream and Initial Guess of the Exit Liquid Composition 16.4-48
4-36	Material Balance Accountability 16.4-49
4-37	Partial Pressure Equilibrium Accountability 16.4-49
4-38	Steam Jet Process Stream Analysis for 1.0 Hour of Operation 16.4-51
4-39	Equilibrium Mole Fraction Concentrations..... 16.4-51
4-40	Estimated Activity Coefficients..... 16.4-51

List of Tables (continued)

Table	Page
4-41 Aqueous Phase Condensate Feasibility Analysis	16.4-52
4-42 Non-Aqueous Phase Condensate Feasibility Analysis	16.4-52
4-43 Iterative Solution to Vacuum Steam Jet Problem with Aqueous Phase Condensate.....	16.4-53
4-44 Condenser Material Balance at Completion of Iterations.....	16.4-54
4-45 Exit Vent Stream Analysis Table	16.4-54
6-1 Standard Conditions for Ideal Gases	16.6-2

[This page intentionally left blank.]

1.0 Introduction

The purpose of this guideline document is to describe emission estimation techniques for point sources in an organized manner and to provide concise example calculations to aid in the preparation of emission inventories. While emissions estimates are not provided, the information presented in this document may be used to select an emission estimation technique best suited to a particular application. This chapter describes the procedures and recommended approaches for estimating emissions from batch chemical manufacturing operations and is intended to assist industry as well as regulatory agency personnel.

As EPA has indicated in this and other EIIIP documents, the choice of methods to be used to estimate emissions depends on how the estimate will be used and the degree of accuracy required, and methods using site-specific data are preferred over other methods. Because this document provides non-binding guidance and is not a rule, EPA, the States, and others retain the discretion to employ or require other approaches that meet the specific requirements of the applicable regulations in individual circumstances.

Section 2 of this chapter identifies some of the types of emission events in chemical manufacturing operations. Section 3 provides an overview of available emission estimation methods for these types of emission events, and section 4 provides an overview of emission estimation methods for emission streams that are routed to condensers or to vacuum devices in which water mixes with the emission stream (i.e., liquid ring vacuum pumps and vacuum steam jets). It should be noted that the use of site-specific emissions data is always preferred over the use of default values developed through use of industry emission averages.

Section 5 provides an overview of considerations that should be used when assessing process vent emissions for basic process unit operations.

Section 6 describes many of the underlying physical property relationships that are used in support of the basic models that are presented in earlier sections of this document.

The techniques presented in this document represent significant advances over previous emission-estimating methods for chemical manufacturing processes. New methodologies are, however, continuously being developed and published by EPA for subsequent incorporation into national environmental policies and programs. The reader is thus encouraged to periodically check the Clearinghouse for Inventories and Emission Factors (CHIEF) website (<http://www.epa.gov/ttn/chief>) to learn about such new information and developments.

[This page intentionally left blank.]

2.0 Source Category Description

2.1 Process Description

This section provides a brief overview of batch chemical manufacturing operations. Chemical processes vary widely from one industry to another with respect to the types of chemicals that are used, batch and production sizes, and unit operations that are involved. However, most chemical processes include at least one or more combinations of four basic operations: preassembly, reaction, isolation, and purification. Solvent recovery operations are also important because they enable the chemical operator to reuse basic raw materials and reduce the manufacturing cost and environmental impact. Additionally, cleanout operations are important since they enable production equipment to be reused for other manufacturing operations.

- **Preassembly.** A preassembly (or premixing) is normally the initial step of the process and typically involves charging, mixing, or dissolving various liquids, solids, and/or gases. Essential equipment for this step might include agitated vessels or tanks with charge chutes, liquid inlet lines, and utility connections for temperature and pressure control. For certain continuous chemical processes, feed preparation might involve inline mixers with heat exchangers.
- **Reaction.** The purpose of the reaction step is to facilitate the actual chemical synthesis. A reaction may be carried out by applying heat or by adding specific reactants to the batch. The batch composition changes as the reaction takes place although many of the compounds such as process solvents and other materials remain unchanged. Equipment that is used to carry out reactions includes a batch, semi-continuous stirred tank or tubular reactor. The actual reactor used must meet the specific chemical, physical, and productivity needs of the process design.
- **Isolation.** Once chemical products have been formed from reaction, they must be recovered or isolated from basic process impurities that also formed or from unreacted materials and/or process solvents. In many cases the product is solid portion of a batch slurry. Isolation can be achieved through the use of spray driers coupled with various dust collectors. Extraction, crystallization filtration, or distillation might be applied in cases when the batch product is a homogeneous solution. Distillation is often used for collecting liquid products when the vapor pressure/temperature relationships can be exploited.
- **Purification.** Once isolated, chemical products must be further processed through purification equipment to obtain the desired high purity level. Products from this purification step are to be used either as the final product or as a key ingredient in the next step of a multi-step synthesis. For example, in a pharmaceutical process a low quality product might be purified by carbon treatment, additional extractions, ion exchange, chromatography, or crystallization. The overall purification process involves other preassembly, purification, and final isolation steps.

2.2 Emission Sources

The majority of emissions that occur from batch chemical manufacturing operations are from volatile organic solvents that evaporate during manufacturing. Particulate matter emissions may also occur from the handling of solid powders that are used in manufacturing.

Several air emission sources have been identified for chemical manufacturing operations; they are as follows:

- Process operations

- Storage tanks
- Equipment leaks
- Wastewater collection and treatment
- Cleaning
- Solvent recovery
- Spills

2.2.1 Process Operations

2.2.1.1 Material Charging Emissions

Volatile Organic Compounds (VOC) emissions may occur during material loading of equipment due to the displacement of organic vapors.

Particulate matter (PM) and PM equal to or less than 10 micrometers in diameter (PM10) emissions may also occur during the material loading process from handling of solids in powder form. VOC and PM emissions during material loading emissions may occur as point source or fugitive, depending on whether a PM emissions collection system is in place.

2.2.1.2 Emissions from Process Heating

Many processes involve batch heating in conjunction with a reaction or in preparing for distillation. As the batch temperature is increased to a new level, the molar capacity of the vessel headspace is reduced due to the ideal gas law ($PV=nRT$). Additionally, the vapor pressures of volatile materials in the batch also increase. Vapors from vessel headspace are emitted through the process vent until the final temperature is reached.

2.2.1.3 Emissions from Process Depressurization

Reducing the system pressure is one way that solvents can be recovered from the batch at a lower temperature than would normally be possible. In some cases it is desired to replace the primary process solvent with a different one at reduced temperature. In other cases it may be desired to concentrate the batch through solvent stripping at reduced temperature to avoid thermal decomposition of compounds in the batch. When the pressure of the batch is reduced then solvent vapors are drawn from the vessel (and connected equipment) by the vacuum system.

2.2.1.4 Emissions from Gas Evolution Processes

Some reactions produce off gases such as hydrogen chloride, sulfur dioxide, and others that evolve from the batch and exit the process through the vessel vent. These off gases will also carry solvent vapors from the batch with them.

2.2.1.5 Emissions from Gas Sweep and Purge Operations

Nitrogen is frequently applied to the process vessel as a means of establishing inert conditions for safety purposes or to prevent moisture from entering the system and avoiding undesirable chemical reactions to take place. As nitrogen enters the vessel it must exit the vessel through the process vent along with solvent vapors from the vessel.

2.2.1.6 Surface Evaporation

Surface evaporation may occur during mixing and blending operations if the vessel contents are exposed to the atmosphere.

2.2.2 Miscellaneous Operations

2.2.2.1 Solvent Reclamation

Solvent reclamation refers to the purification of contaminated or spent solvent through distillation. VOC emissions occur from the solvent charging and the normal distillation equipment operation.

2.2.2.2 Cleaning

Cleaning is an important ancillary part of the chemical manufacturing process. Process equipment may be cleaned with solvent as often as after each batch. VOC emissions will result from any of the normal process operations such as charging, heating, gas sweep, and others. Additionally, emissions will result from the wiping of equipment with solvent wet clothes. In addition to this type of cleaning, small items used in the chemical manufacturing process may be cleaned by washing with solvents in a cold cleaner or open-top vapor degreaser.

2.2.3 Wastewater Treatment

A chemical manufacturing facility may use a wastewater treatment system to treat contaminated water generated during the chemical manufacturing process (e.g., water that has been used to clean equipment, extractions, crystallizations, and other operations). Wastewater treatment systems generally consist of a series of surface impoundments that are used for equalization, neutralization, aeration, and clarification of the waste stream. Fugitive VOC emissions may occur from each type of basin. Procedures used to estimate emissions from wastewater treatment facilities are described in detail in Volume II, Chapter 5, *Preferred and Alternative Methods for Estimating Air Emissions from Wastewater Collection and Treatment*.

2.2.4 Storage Tanks

Various types and sizes of storage tanks are used to store solvents and resins used in the chemical manufacturing process. Most of these tanks have a fixed-roof design. The two significant types of emissions from fixed-roof tanks are breathing and working losses. Breathing loss is the expulsion of vapor from a tank through vapor expansion and contraction that result from changes in ambient temperature and barometric pressure. This loss occurs without any liquid level change in the tank. The combined loss from filling and emptying tanks is called working loss. Evaporation during filling operations results from an increase in the liquid level in the tank. As the liquid level increases, the pressure inside the tank exceeds the relief pressure and vapors are expelled from the tank. Evaporative emissions during emptying occur when air drawn into the tank during liquid removal becomes saturated with organic vapor and expands, expelling vapor through the vapor relief valve (EPA, 1995a). Emissions from tanks are characterized as a point source because VOCs are released through a vent.

2.2.5 Equipment Leaks

In order to transport stored materials (e.g., organic solvents and resins) from storage tanks to the chemical manufacturing operation, a network of pipes, pumps, valves, and flanges is employed. As liquid material is pumped from the storage tanks to the particular process area, the pipes and supporting hardware

(process line components) may develop leaks over time. When leaks occur, volatile components in the transported material are released to the atmosphere. This generally occurs from the following process line components:

- Pump seals
- Valves
- Compressor seals
- Safety relief valves
- Flanges
- Open-ended lines
- Sampling connections.

Emissions from equipment leaks can be characterized as fugitive and are described in detail in Volume II, Chapter 4, *Preferred and Alternative Methods for Estimating Fugitive Emissions from Equipment Leaks*.

2.2.6 Spills

Solvents, resins, or product may be accidentally spilled during manufacturing or cleaning activities. Materials that are spilled onto the ground may spread over an area, vaporize, and thus result in an air emission (EPA, 1987). Such an emission would be characterized as fugitive.

2.3 Process Design and Operating Factors Influencing Emissions

VOC and PM emissions from chemical manufacturing may be reduced through the use of add-on control systems or through equipment and process modifications.

2.3.1 VOC Control Systems

A VOC control system typically consists of a capture device and a removal device. The capture device (such as a hood or enclosure) captures the VOC-laden air from the emission area and ducts the exhaust air stream to removal equipment such as a recovery device or a destructive control device. In either case, the purpose of the control device is to remove VOCs from the exhaust air stream. The overall efficiency of a control system is a function of the specific removal efficiency for each device in the system.

Example recovery devices:

- Condensers are one of the most frequently used control devices in industry. They work by reducing the temperature of the emission exhaust gas to a cold enough temperature so that VOC vapors are recovered through condensation.
- Adsorption Devices that incorporate activated carbon are capable of removing VOC vapors from exhaust emission streams to very low levels in the final gas stream. Large scale adsorption based recovery systems normally have two or more activated carbon adsorption chambers. One carbon chamber is being used to remove VOCs from emission stream while the spent carbon chamber is being regenerated. VOCs are recovered from the system during the regeneration phase. Steam is routed into the saturated carbon bed to cause the VOCs to desorb from the carbon and condense at the condenser. Once VOCs liquids have been collected then they may be recycled or further purified prior to reuse in the manufacturing operation.

- Dust collectors are used to collect particulate matter from the emission stream. Dust collectors are constructed in many different designs. A bag house consists of a large rectangular housing with many internal banks of vertically mounted filter bags. The emission stream enters the bag house through the side inlet, passes through the bag filter media, and exits the unit through the discharge port at the top. Particulate matter builds up on the filter media until it is shaken off by pulses of compressed air from within each bag. The dust that falls from the bags during the pulsing process is collected at the lower section of the bag house and finally discharged through the solids outlet to a drum or other container. When designing a bag house for an installation it is important to select the appropriate filter media and surface area for the particulate matter to be collected. The pore size of the filter cloth will determine the removal efficiency of the overall unit.
- A floating roof on a storage tank helps to reduce solvent emissions by eliminating the headspace that is present in conventional storage tanks. For the conventional storage tank air that is saturated with solvent vapors exits the vessel as the surrounding temperature increases during the day. Outside air then reenters the vessel during the evening hours as the surrounding temperature decreases and the daily cycle prepares to be repeated. Additionally, when a conventional storage tank is filled periodically then emission occur by way of displacement. A floating roof moves up and down the vessel vertical walls as the level of the storage tank changes. Since the vessel contains no headspace all breathing and filling losses are avoided.

Example destructive control devices:

- Catalytic Incinerators are used to eliminate VOCs from process exhaust gases from a broad variety of process operations. Catalytic incineration is a technology used in selective applications to greatly reduce emissions due to VOCs, hydrocarbons, odors, and opacity in process exhaust. The catalyst section operates at between 315°C to 400°C to convert VOC to CO₂ and H₂O. A properly designed and installed system can achieve a VOC destruction efficiency of greater than 95%.
- Thermal Incinerators control VOC levels in a gas stream by passing the stream through a combustion chamber where the VOCs are burned in air at temperatures between 700°C to 1,300°C. Fuel is burned in the unit to supply the necessary heat for decomposition of the VOC's. Heat exchangers may also be installed as part of the unit to conserve energy by warming the inlet air stream with the hot exhaust gases.
- Venturi Scrubbers are used to remove particulate material from vent exhaust streams. These units normally incorporate a spray nozzle section where liquid is discharged at a high velocity, a mixing section where liquid droplets contact the incoming emission gas stream, and a settling/separation section where scrubber fluid is recycled to the inlet spray nozzle and the exit gas is discharged to the atmosphere or to a secondary control device.
- Enclosed Oxidizing Flares convert VOCs into CO₂ and H₂O by way of direct combustion. Normally an enclosed oxidizing flare is used when the waste gas is rich enough in organic content to be its own fuel source. If the process gas stream does not contain an adequate level of combustible VOCs then additional fuel must be supplied for effective operation.

The removal efficiency for each control device is a function of the specific design of the unit and how well its capability matches the intended application. Before selecting pollution equipment one should consult different manufacturers and/or engineering firms to determine the most appropriate control device solution for a given application.

2.3.2 PM/PM₁₀ Control Systems

PM/PM₁₀ control systems for the chemical industry consist of a capture device paired with a control device that is typically a fabric filter (bag house). These systems are typically employed to reduce PM emissions from charging pigments and other solids into mixing and grinding devices. The captured dust may be recycled or sent for off-site disposal or treatment.

Bag Houses remove particulate material from an emission gas stream by passing the emission stream through engineered fabric filter tubes, envelopes, or cartridges. Particulate material is retained on the filter media as the clean air is discharged to the atmosphere. Vibrators or timed air blast are used for removing and discharging the dust that has been collected in the unit. When identifying a bag house for an application it is important to consider the particle size in the emission stream, the particle size control requirements, the air flow rate of the emission stream, and the bag filter surface area requirements. Additionally, it is important to identify the appropriate chemical resistance requirements for the materials of construction in the unit.

Fabric filters are least efficient with particles 0.1 to 0.3 μm in diameter and with emission streams of high moisture content. When operated under optimum conditions, they can generally achieve control efficiencies of up to 99+ percent (EIIP, 2000). However, typical control efficiencies range from 95 to 99 percent.

3.0 Basic Air Emission Models

Processes for chemical manufacturing consist of different unit operations including filling, mixing, heating, depressurization, gas sweep, gas evolution, dispersing, milling, and others. A mathematical approach to estimating air emissions from these types of processes is to model them as collection of separate unit operations. This section contains several models that can be applied to many of the operations within these processes. For example, the filling model can be used to estimate the emissions from charging the primary raw materials or transferring the batch from one vessel to a second vessel. The heating and filling models can be used to model distillation operations.

3.1 Vessel Filling

When a solvent or volatile process mixture is charged into a process vessel then material losses will occur though the process vent in the form of solvent vapors. The amount of solvent that is emitted during this displacement operation is a function of the (1) volume of liquid entering the tank, (2) the equilibrium vapor pressure of each component that is contained in the inlet stream and/or present in the vessel before the filling operation begins, and (3) degree of saturation of the associated vapors. The resulting emission rate is simply a function of how quickly the filling operation takes place.

The equilibrium vapor pressure for each volatile component in the system is calculated by applying Raoult's Law to the pure vapor pressure and the mole fraction of each compound in the inlet stream and/or initial vessel contents. If non-idealities exist between molecules in the system then activity coefficient may be used to adjust the vapor pressures accordingly. The calculated equilibrium vapor pressure represents the gas space composition assuming that the degree of vapor saturation is 100%. It is highly possible that the actual saturation level of the solvent vapors may be less than the assumed 100% level. For example, if representative samples have been taken of the gas space and analyzed then this data may be substituted for the calculated vapor pressure values. However, the conservative approach is normally applied and a 100% saturation level is assumed in most cases.

Displacement emissions that are caused by charging operations may be calculated using the ideal gas law on the volume of gas that is emitted. This equation assumes that the partial pressure of component i in the vent gas is at saturated levels.

Ideal Gas Law:
$$E_{n-i} = \frac{p_i V}{RT} \quad \text{Eq. 3-1}$$

Where E_{n-i} are the moles of component i that are emitted due to vapor displacement
 p_i is the saturated vapor pressure of component i .
 V is the displacement volume that was caused by the filling operation.
 R is the ideal gas constant in consistent units,
 T is the temperature of the liquid being charged

3.1.1 Charging to an Empty Vessel

When a solvent mixture is being charged to an empty vessel then the vapor composition for the displacement calculation may be made based entirely upon the inlet stream composition.

$$p_i = x_i \gamma_i P_i \quad \text{Eq. 3-2}$$

Where p_i = effective vapor pressure for component i
 x_i = mole fraction of component i
 γ_i = component activity coefficient (Becomes 1.0 when Raoult's Law applies)
 P_i = pure component pressure i

Illustration 3-1: Charging a pure solvent to an empty vessel.

A 5,000 gallon reactor is filled at ambient conditions (25°C and 1 atm) with 3,600 gallons of hexane in one hour. The empty vessel was previously made inert with nitrogen, and the vessel is vented to atmosphere. Calculate the vapor emissions from this process.

Step 1. The displaced gas is defined by the following conditions.

T	=	25°C	=	298°K	(System temperature)
P _{System}	=	1.0 atm	=	760 mm Hg	(Total system pressure)
V _{displacement}	=	3600 gal	=	481.28 ft ³	(Displacement volume)
Time	=	1 hr			(Time for event)

Constants and Relationships:

Universal Gas Constant:
$$R = 998.9 \frac{\text{mmHg} \cdot \text{ft}^3}{\text{lb} - \text{mole} \cdot ^\circ\text{K}}$$

Antoine Equation:
$$P_i = \exp\left(a - \frac{b}{T + c}\right)$$

Gas Law:
$$n = \frac{PV}{RT} \text{ also } n_i = \frac{P_i V}{RT} \text{ for component } i \text{ in the gas space.}$$

Sum of the partial pressures in the gas space:
$$P_T = \sum_{i=1}^N p_i$$

Sum of component moles in the gas space:
$$N_T = \sum_{i=1}^N n_i$$

Step 2. Calculate the amount of each component in the displaced gas.

Hexane is the only component in the liquid, so the vapor pressure for hexane is only a function of the system temperature, 25°C. The partial pressure of nitrogen is determined by the difference between the total system pressure, 760 mm Hg, and the partial pressure of hexane. The vapor pressure of hexane may be calculated from the Antoine equation as follows:

$$p_{\text{hexane}} = \exp\left(15.8366 - \frac{2697.55}{298.15 - 48.78}\right) = \exp(5.019) = 151.28 \text{ mmHg}$$

therefore
$$p_{N_2} = P_T - p_{\text{hexane}} = 760 \text{ mmHg} - 151.28 \text{ mmHg} = 608.719 \text{ mmHg}$$

Ideal Gas Law:
$$E_{n\text{-hexane}} = \frac{p_{\text{hexane}} V}{RT} = \frac{151.281 \text{ mmHg} \cdot 481.28 \text{ ft}^3}{(998.9)(25^\circ\text{C} + 273.15)} = 0.244 \text{ lb} - \text{moles}$$

$$E_{n-N_2} = \frac{p_{N_2} V}{RT} = \frac{608.719 \text{ mmHg} \cdot 481.28 \text{ ft}^3}{(998.9)(298.15)} = 0.984 \text{ lb-moles}$$

Emission level: $E_{Wt-hexane} = (0.244 \text{ lb-moles}) \left(86.17 \frac{\text{lb}}{\text{lb-mole}} \right) = 21.03 \text{ lb}$

$$E_{Wt-N_2} = (0.984 \text{ lb-moles}) \left(28.01 \frac{\text{lb}}{\text{lb-mole}} \right) = 27.562 \text{ lb}$$

Step 3. Calculate the emission rate based on the 1 hour addition.

Emission Rates: $E_{R-hexane} = \frac{21.03 \text{ lb}}{1.0 \text{ hr}} = 21.03 \frac{\text{lb}}{\text{hr}}$

$$E_{R-N_2} = \frac{27.56 \text{ lb}}{1.0 \text{ hr}} = 27.56 \frac{\text{lb}}{\text{hr}}$$

Illustration 3-2: Charging a solvent mixture to an empty vessel.

A 50-50 volume percent solvent mixture of heptane and toluene is charged to a surge tank at a rate of 50 gal/min. A total of 1,500 gal of mixed solvent is charged at 20°C.

Step 1. Define conditions of the displaced gas:

T	=	20°C	=	298.15°K	(System temperature)
P _T	=	1.0 atm	=	760 mm Hg	(Total system pressure)
V _{disp}	=	1,500 gal	=	200.53 ft ³	(Displacement volume)
Time	=	5 min			(Time for event)

Constants and Relationships:

Universal Gas Constant: $R = 998.9 \frac{\text{mmHg} \cdot \text{ft}^3}{\text{lb-mole} \cdot ^\circ\text{K}}$

Antoine Vapor Pressure Equation: $P_i = \exp\left(a - \frac{b}{T+c}\right)$

Gas Law: $n = \frac{PV}{RT}$, also $n_i = \frac{p_i V}{RT}$ for a single component i in the gas space.

Sum of the partial pressures in the gas space: $P_T = \sum_{i=1}^N p_i$

Sum of component moles in the gas space: $N_T = \sum_{i=1}^N n_i$

Step 2. Calculate the vapor-phase mole fractions:

VOC	Mol. Wt. lb/lbmole	Density lb/gal	Volume Charged	Weight Charged	lb-moles	Xi
Heptane	100.205	5.6977	750	4,273.3	42.65	0.42
Toluene	92.13	7.2138	750	5,410.3	58.72	0.58
Total					101.37	1.00

In this problem, heptane and toluene coexist in a miscible liquid. The vapor space partial pressure for each compound may be estimated from the pure component pressure and liquid composition using Raoult's Law. It is assumed that the vessel contains nitrogen as the remaining gas component. Pure component vapor pressures for the liquid components may be estimated using the Antoine equation.

$$P_{heptane} = \exp\left(15.8737 - \frac{2911.32}{293.15 - 56.51}\right) = \exp(3.571) = 35.55 \text{ mmHg}$$

$$P_{toluene} = \exp\left(16.0137 - \frac{3096.52}{293.15 - 53.67}\right) = \exp(3.0835) = 21.84 \text{ mmHg}$$

VOC	Xi	Pi (mm Hg)	pi (mm Hg)
Heptane	0.42	35.55	14.93
Toluene	0.58	21.84	12.67
Nitrogen	0.0		732.40

Ideal Gas Law:

$$E_{n\text{-heptane}} = \frac{P_{heptane} V}{RT_{sys}} = \frac{14.93 \text{ mmHg} \cdot 200.53 \text{ ft}^3}{(998.9)(293.15)} = 0.0102 \text{ lb-moles}$$

$$n_{n\text{-toluene}} = \frac{P_{toluene} V}{RT_{sys}} = \frac{12.67 \text{ mmHg} \cdot 200.53 \text{ ft}^3}{(998.9)(293.15)} = 0.0087 \text{ lb-moles}$$

$$n_{nitrogen} = \frac{P_{air} V}{RT_{sys}} = \frac{732.40 \text{ mmHg} \cdot 200.53 \text{ ft}^3}{(998.9)(293.15)} = 0.5015 \text{ lb-moles}$$

Emission level:

$$E_{Wt\text{-heptane}} = (0.0102 \text{ lb-moles}) \left(100.205 \frac{\text{lbs}}{\text{lb-mole}}\right) = 1.02 \text{ lbs}$$

$$E_{Wt\text{-toluene}} = (0.0087 \text{ lb-moles}) \left(92.13 \frac{\text{lbs}}{\text{lb-mole}}\right) = 0.80 \text{ lbs}$$

$$E_{Wt\text{-nitrogen}} = (0.5015 \text{ lb-moles}) \left(28.0134 \frac{\text{lbs}}{\text{lb-mole}}\right) = 14.05 \text{ lbs}$$

Step 3. Calculate the emission rate in lb/hr units.

Since 1,500 of solvent mixture is charged at 50 gpm the complete charge is completed in 30 minutes.

$$E_{R\text{-heptane}} = 1.02 \text{ lbs} \left(\frac{60 \text{ min/hr}}{30 \text{ min}} \right) = 2.04 \text{ lbs/hr}$$

$$E_{R\text{-toluene}} = 0.80 \text{ lbs} \left(\frac{60 \text{ min/hr}}{30 \text{ min}} \right) = 1.6 \text{ lbs/hr}$$

$$E_{R\text{-nitrogen}} = 14.05 \text{ lbs} \left(\frac{60 \text{ min/hr}}{30 \text{ min}} \right) = 28.1 \text{ lbs/hr}$$

3.1.2 Charging to a Partially Filled Vessel with Miscible Contents

When a liquid mixture is charged to a vessel that already contains process material from a prior process operation then the vessel contents composition will dynamically change as the charging operation takes place. The equilibrium vapor composition above the batch will also change in accordance to the batch composition.

At any point in the filling operation one may calculate the batch composition from the initial vessel contents and the amount of material that has been added. Let n_A represent the moles of inlet mixture that are to be added to the vessel and let N_B represent the total number of moles of mixture that are initially contained in the vessel regardless of composition. For example, if the inlet stream contained ethanol, water, and methanol then n_A would represent the total moles of ethanol, water, and methanol that have been charged at any point in the operation.

$$\varphi_A = \frac{n_A}{n_A + N_B} \quad \text{Eq. 3-3}$$

Where φ_A is the degree of dilution of the inlet stream mixture at any point during the addition, n_A are the moles of inlet steam mixture charged to the vessel, and N_B are the moles of mixture that were initially contained in the vessel prior to the addition.

The average dilution $\bar{\varphi}_A$ of the inlet stream A from being mixed with the contents of the vessel may be calculated by integrating a differential expression for $d\varphi_A$ with respect to moles of inlet mixture A and then dividing the results by the total number of moles of mixture A that were charged. [Hatfield, 2003d].

$$\bar{\varphi}_A = \frac{1}{N_A} \int_0^{N_A} \frac{n_A}{(n_A + N_B)} dn_A \quad \text{Eq. 3-4}$$

$$\bar{\varphi}_A = 1 + \frac{N_B}{N_A} \ln \left(\frac{N_B}{N_A + N_B} \right) \quad \text{Eq. 3-5}$$

A similar calculation may be made for the average dilution factor of mixture B (the initial vessel contents) that exists during the filling process.

$$\bar{\varphi}_B = \frac{N_B}{N_A} \int_0^{N_A} \frac{1}{(n_A + N_B)} dn_A \quad \text{Eq. 3-6}$$

$$\bar{\varphi}_B = -\frac{N_B}{N_A} \ln\left(\frac{N_B}{N_A + N_B}\right) \quad \text{Eq. 3-7}$$

Once $\bar{\varphi}_A$ and $\bar{\varphi}_B$ are determined then the average batch composition that exists during the filling operation may be calculated by multiplying the composition of each mixture by its corresponding integrated average dilution factor.

When the filling operation involves subsurface addition then the inlet stream is exposed to the vessel headspace only as it mixes with the vessel contents. In this case only the average batch composition that exists during the filling operation is used to calculate the average vessel headspace vapor composition. $\bar{\varphi}_A$ and $\bar{\varphi}_B$ are calculated

However, if the operation involves above surface addition then the inlet stream is exposed directly to the headspace in the vessel. The equilibrium vapor pressure of the inlet stream must then be considered as an independent source of vapors in addition to the average batch composition.

3.1.2.1 Subsurface Addition

Illustration 3-3: Charging a mixture to a partially filled vessel (subsurface addition).

Three hundred gallons of acetone at 20°C are to be added to the vessel featured in Illustration 2 by way of subsurface addition. For this problem, the initial contents of the vessel are 1,500 gallons of a mixture of heptane (42% mole fraction) and toluene (58% mole fraction) at 20°C. The system pressure is 760 mm Hg and the addition process is complete in 0.5 hour.

Step 1. Define conditions of the displaced gas.

T	=	20°C	=	298.15°K	(System temperature)
PT	=	1.0 atm	=	760 mm Hg	(Total system pressure)
V _{disp}	=	300 gal	=	40.1 ft ³	(Displacement volume)
Time	=	30 min			(Time for event)
Acetone	=	6.5632 lb/gal @ 20°C			

Constants and Relationships:

Universal Gas Constant:
$$R = 998.9 \frac{\text{mmHg} \cdot \text{ft}^3}{\text{lb} - \text{mole} \cdot ^\circ\text{K}}$$

Antoine Vapor Pressure Equation:
$$P_i = \exp\left(a - \frac{b}{T + c}\right)$$

Gas Law:
$$n = \frac{PV}{RT}, \text{ also } n_i = \frac{p_i V}{RT} \text{ for a single component } i \text{ in the gas space.}$$

Sum of the partial pressures in the gas space:
$$P_T = \sum_{i=1}^N p_i$$

Sum of component moles in the gas space:
$$N_T = \sum_{i=1}^N n_i$$

Step 2. Calculate the dilution factors for the inlet stream and the initial vessel contents.

Inlet Stream Analysis:

VOC	Mol. Wt. lb/lbmole	Density lb/gal	Volume Charged	Weight Charged	lb-moles	X _i
Acetone	58.08	6.5632	300	1968.96	33.90	1.00
Total					33.90	1.00

Initial Vessel Contents Analysis:

VOC	Mol. Wt. lb/lbmole	Density lb/gal	Volume Charged	Weight Charged	lb-moles	X _i
Heptane	100.205	5.6977	750	4,273.3	42.65	0.42
Toluene	92.13	7.2138	750	5,410.3	58.72	0.58
Total					101.37	1.00

Calculate the inlet stream dilution factor:

From Eq 3.5:

$$\bar{\varphi}_A = 1 + \frac{N_B}{N_A} \ln \left(\frac{N_B}{N_A + N_B} \right)$$

$$\bar{\varphi}_A = 1 + \frac{101.37}{33.90} \ln \left(\frac{101.37}{33.90 + 101.37} \right)$$

$$\bar{\varphi}_A = 1 + 2.99 \ln(0.7494) = 0.14$$

Calculate the dilution factor for the initial vessel contents:

From Eq 3.7

$$\bar{\varphi}_B = -\frac{N_B}{N_A} \ln \left(\frac{N_B}{N_A + N_B} \right)$$

$$\bar{\varphi}_B = -\frac{101.37}{33.90} \ln \left(\frac{101.37}{33.90 + 101.37} \right)$$

$$\bar{\varphi}_B = -2.99 \ln(0.7494) = 0.86$$

Step 3. Calculate the average batch and vapor-phase compositions.

VOC	X _i	φ _A , φ _B	\bar{X}_i	P _i (mm Hg)	p _i (mm Hg)
Acetone	1.00	0.14	0.14	184.80	25.87
Heptane	0.42	0.86	0.36	35.55	12.80
Toluene	0.58	0.86	0.50	21.84	10.92
Nitrogen					710.41
Total	1.00		1.00		760.00

Ideal Gas Law:

$$E_{n\text{-acetone}} = \frac{P_{\text{acetone}}V}{RT_{\text{sys}}} = \frac{25.87\text{mmHg} \cdot 40.1\text{ft}^3}{(998.9)(293.15)} = 0.00354 \text{ lb-moles}$$

$$E_{n\text{-heptane}} = \frac{P_{\text{heptane}}V}{RT_{\text{sys}}} = \frac{12.83\text{mmHg} \cdot 40.1\text{ft}^3}{(998.9)(293.15)} = 0.00176 \text{ lb-moles}$$

$$E_{n\text{-toluene}} = \frac{P_{\text{toluene}}V}{RT_{\text{sys}}} = \frac{10.92\text{mmHg} \cdot 40.1\text{ft}^3}{(998.9)(293.15)} = 0.0015 \text{ lb-moles}$$

$$E_{n\text{-nitrogen}} = \frac{P_{\text{nitrogen}}V}{RT_{\text{sys}}} = \frac{710.41\text{mmHg} \cdot 40.1\text{ft}^3}{(998.9)(293.15)} = 0.0973 \text{ lb-moles}$$

Emission level:

$$E_{\text{wt-acetone}} = (0.00354\text{lb-moles}) \left(58.08 \frac{\text{lbs}}{\text{lb-mole}} \right) = 0.21 \text{ lbs}$$

$$E_{\text{wt-heptane}} = (0.00176\text{lb-moles}) \left(100.205 \frac{\text{lbs}}{\text{lb-mole}} \right) = 0.18 \text{ lbs}$$

$$E_{\text{wt-toluene}} = (0.0015\text{lb-moles}) \left(92.13 \frac{\text{lbs}}{\text{lb-mole}} \right) = 0.14 \text{ lbs}$$

$$E_{\text{wt-nitrogen}} = (0.0973\text{lb-moles}) \left(28.0134 \frac{\text{lbs}}{\text{lb-mole}} \right) = 2.73 \text{ lbs}$$

Step 4. Calculate the emission rate in lb/hr units.

$$E_{R\text{-acetone}} = \frac{0.21 \text{ lbs}}{0.5 \text{ hr}} = 0.42 \text{ lbs/hr}$$

$$E_{R\text{-heptane}} = \frac{0.18 \text{ lbs}}{0.5 \text{ hr}} = 0.36 \text{ lbs/hr}$$

$$E_{R\text{-toluene}} = \frac{0.28 \text{ lbs}}{0.5 \text{ hr}} = 0.56 \text{ lbs/hr}$$

$$E_{R\text{-nitrogen}} = \frac{2.73 \text{ lbs}}{0.5 \text{ hr}} = 5.46 \text{ lbs/hr}$$

3.1.2.2 Above Surface Addition

Illustration 3-4: Charging a mixture to a partially filled vessel (above surface addition).

Three hundred gallons of acetone at 20°C are to be added to the vessel featured in Illustration 3-2 by way of above surface addition. For this problem, the initial contents of the vessel are 1,500 gallons of a mixture of heptane (42% mole fraction) and toluene (58% mole fraction) at 20°C. The system pressure is 760 mm Hg and the addition process is complete in 0.5 hours.

For this problem, the inlet stream is in direct contact with the vessel headspace as it enters the vessel. Therefore, the equilibrium vapor composition for the inlet stream will be based on the exact composition of the inlet stream. A dilution factor $\bar{\varphi}_A$ for the inlet stream will be assumed to be 1.0.

Step 1. Define the conditions of the displaced vent gas:

T	=	20°C	=	298.15°K	(System temperature)
PT	=	1.0 atm	=	760 mm Hg	(Total system pressure)
V _{disp}	=	300 gallons	=	40.1 ft ³	(Displacement volume)

Time = 30 min (Time for event)
 Acetone = 6.5632 lb/gal @ 20°C

Constants and Relationships:

Universal Gas Constant: $R = 998.9 \frac{\text{mmHg} \cdot \text{ft}^3}{\text{lb-mole} \cdot ^\circ\text{K}}$

Antoine Vapor Pressure Equation: $P_i = \exp\left(a - \frac{b}{T + c}\right)$

Gas Law: $n = \frac{PV}{RT}$ also $n_i = \frac{p_i V}{RT}$ for a single component i in the gas space.

Sum of the partial pressures in the gas space: $P_T = \sum_{i=1}^N p_i$

Sum of component moles in the gas space: $N_T = \sum_{i=1}^N n_i$

Step 2. Calculate the dilution factor for the initial vessel contents.

Inlet Stream Analysis:

VOC	Mol. Wt. lb/lbmole	Density lb/gal	Volume Charged	Weight Charged	lb-moles	X _i
Acetone	58.08	6.5632	300	1968.96	33.90	1.00
Total					33.90	1.00

Initial Vessel Contents Analysis:

VOC	Mol. Wt. lb/lbmole	Density lb/gal	Volume Charged	Weight Charged	lb-moles	X _i
Heptane	100.205	5.6977	750	4,273.3	42.65	0.42
Toluene	92.13	7.2138	750	5,410.3	58.72	0.58
Total					101.37	1.00

Calculate the dilution factor for the initial vessel contents:

From Eq 3-7

$$\bar{\phi}_B = -\frac{N_B}{N_A} \ln\left(\frac{N_B}{N_A + N_B}\right)$$

$$\bar{\phi}_B = -\frac{101.37}{33.90} \ln\left(\frac{101.37}{33.90 + 101.37}\right)$$

$$\bar{\phi}_B = -2.99 \ln(0.7494) = 0.86$$

Step 3. Calculate the average batch and vapor-phase compositions.

VOC	X _i	φ _A , φ _B	\bar{X}_i	P _i (mm Hg)	P _i (mm Hg)
Acetone	1.00	1.00	1.00	184.80	184.80
Heptane	0.42	0.86	0.36	35.55	12.80
Toluene	0.58	0.86	0.50	21.84	10.92
Nitrogen					551.48
Total	1.00		1.00		760.00

Ideal Gas Law:
$$E_{n\text{-acetone}} = \frac{p_{\text{acetone}} V}{RT_{\text{sys}}} = \frac{184.80 \text{ mmHg} \cdot 40.1 \text{ ft}^3}{(998.9)(293.15)} = 0.0253 \text{ lb-moles}$$

$$E_{n\text{-heptane}} = \frac{p_{\text{heptane}} V}{RT_{\text{sys}}} = \frac{12.83 \text{ mmHg} \cdot 40.1 \text{ ft}^3}{(998.9)(293.15)} = 0.00176 \text{ lb-moles}$$

$$E_{n\text{-toluene}} = \frac{p_{\text{toluene}} V}{RT_{\text{sys}}} = \frac{10.92 \text{ mmHg} \cdot 40.1 \text{ ft}^3}{(998.9)(293.15)} = 0.0015 \text{ lb-moles}$$

$$E_{n\text{-nitrogen}} = \frac{p_{\text{nitrogen}} V}{RT_{\text{sys}}} = \frac{551.48 \text{ mmHg} \cdot 40.1 \text{ ft}^3}{(998.9)(293.15)} = 0.0755 \text{ lb-moles}$$

Emission level:
$$E_{\text{wt-acetone}} = (0.0253 \text{ lb-moles}) \left(58.08 \frac{\text{lbs}}{\text{lb-mole}} \right) = 1.47 \text{ lbs}$$

$$E_{\text{wt-heptane}} = (0.00176 \text{ lb-moles}) \left(100.205 \frac{\text{lbs}}{\text{lb-mole}} \right) = 0.18 \text{ lbs}$$

$$E_{\text{wt-toluene}} = (0.0015 \text{ lb-moles}) \left(92.13 \frac{\text{lbs}}{\text{lb-mole}} \right) = 0.14 \text{ lbs}$$

$$E_{\text{wt-nitrogen}} = (0.0755 \text{ lb-moles}) \left(28.0134 \frac{\text{lbs}}{\text{lb-mole}} \right) = 2.12 \text{ lbs}$$

Step 4. Calculate the emission rate in lb/hr units.

$$E_{R\text{-acetone}} = \frac{1.47 \text{ lbs}}{0.5 \text{ hr}} = 2.94 \text{ lbs/hr}$$

$$E_{R\text{-heptane}} = \frac{0.18 \text{ lbs}}{0.5 \text{ hr}} = 0.36 \text{ lbs/hr}$$

$$E_{R\text{-toluene}} = \frac{0.28 \text{ lbs}}{0.5 \text{ hr}} = 0.56 \text{ lbs/hr}$$

$$E_{R\text{-nitrogen}} = \frac{2.12 \text{ lbs}}{0.5 \text{ hr}} = 4.24 \text{ lbs/hr}$$

3.1.2.3 Addition of Immiscible Liquids

Illustration 3-5: Charging a mixture to a partially filled vessel (immiscible liquids).

Seven hundred fifty gallons of toluene at 20°C are to be added to the vessel that contains 500 gallons of water at 20°C. The system pressure is 760 mm Hg and the addition process is complete within 0.5 hours.

For this problem, the two mixtures are insoluble and form two distinct liquid phases as the addition process takes place. Therefore, dilution of one stream by the other does not occur and the equilibrium vapor composition is determined based on the initial composition of each mixture.

Step 1. Define conditions of the displaced gas:

T	=	20°C	=	298.15°K	(System temperature)
P _T	=	1.0 atm	=	760 mm Hg	(Total system pressure)
V _{disp}	=	750 gal	=	100.2 ft ³	(Displacement volume)
Time	=	30 min			(Time for event)

Constants and Relationships:

Universal Gas Constant:
$$R = 998.9 \frac{\text{mmHg} \cdot \text{ft}^3}{\text{lb-mole} \cdot ^\circ\text{K}}$$

Antoine Vapor Pressure Equation:
$$P_i = \exp\left(a - \frac{b}{T + c}\right)$$

Gas Law: $n = \frac{PV}{RT}$, also $n_i = \frac{p_i V}{RT}$ for a single component i in the gas space.

Sum of the partial pressures in the gas space:
$$P_T = \sum_{i=1}^N p_i$$

Sum of component moles in the gas space:
$$N_T = \sum_{i=1}^N n_i$$

Step 2. Calculate the dilution factor for the initial vessel contents.

Inlet Stream Analysis:

VOC	Mol. Wt. lb/lb-mole	Density lb/gal	Volume Charged	Weight Charged	lb-moles	X _i
Toluene	92.13	7.2138	750	5,410.4	58.72	1.00
Total					58.72	1.00

Initial Vessel Contents Analysis:

VOC	Mol. Wt. lb/lb-mole	Density lb/gal	Volume	Weight	lb-moles	X _i
Water	18.02	8.33	500	4,165	231.13	1.00
Total					231.13	1.00

Step 3. Calculate the average batch and vapor-phase compositions.

VOC	X _i	P _i (mm Hg)
Toluene	1.00	21.84
Water	1.00	17.35
Nitrogen		720.81
Total	1.00	760.00

$$\text{Ideal Gas Law: } E_{n\text{-toluene}} = \frac{p_{\text{toluene}}V}{RT_{\text{sys}}} = \frac{21.84\text{mmHg} \cdot 100.2\text{ft}^3}{(998.9)(293.15)} = 0.00747 \text{ lb-moles}$$

$$E_{n\text{-water}} = \frac{p_{\text{water}}V}{RT_{\text{sys}}} = \frac{17.35\text{mmHg} \cdot 100.2\text{ft}^3}{(998.9)(293.15)} = 0.00594 \text{ lb-moles}$$

$$E_{n\text{-nitrogen}} = \frac{p_{\text{nitrogen}}V}{RT_{\text{sys}}} = \frac{720.81\text{mmHg} \cdot 100.2\text{ft}^3}{(998.9)(293.15)} = 0.24665 \text{ lb-moles}$$

$$\text{Emission level: } E_{\text{wt-toluene}} = (0.00747\text{lb-moles}) \left(92.13 \frac{\text{lbs}}{\text{lb-mole}} \right) = 0.69 \text{ lbs}$$

$$E_{\text{wt-water}} = (0.00594\text{lb-moles}) \left(18.02 \frac{\text{lbs}}{\text{lb-mole}} \right) = 0.11 \text{ lbs}$$

$$E_{\text{wt-nitrogen}} = (0.24665\text{lb-moles}) \left(28.0134 \frac{\text{lbs}}{\text{lb-mole}} \right) = 6.91 \text{ lbs}$$

Step 4. Calculate the emission rate in lb/hr units.

$$E_{R\text{-toluene}} = \frac{0.69 \text{ lbs}}{0.5 \text{ hr}} = 1.38 \text{ lbs/hr}$$

$$E_{R\text{-water}} = \frac{0.11 \text{ lbs}}{0.5 \text{ hr}} = 0.22 \text{ lbs/hr}$$

$$E_{R\text{-nitrogen}} = \frac{6.91 \text{ lbs}}{0.5 \text{ hr}} = 13.82 \text{ lbs/hr}$$

3.2 Purge/Gas Sweep Models**3.2.1 Purge or Gas Sweep – Empty Vessel Purge**

When a gas purge is applied to an empty vessel that still contains residual vapors from a previous process operation then compound emissions may be determined by the following expression.

$$E_{n-i} = \frac{P_{i,l}V}{RT} \left(1 - e^{-Ft/V} \right)$$

Where E_{n-i} are the moles of component i that are emitted due to vapor displacement,
 $p_{i,l}$ is the saturated vapor pressure of component i at initial conditions,

V is the gas space volume of vessel when empty,
 R is the ideal gas constant in consistent units,
 T is the temperature of the liquid being charged,
 F is the purge gas flowrate,
 t is the elapsed time for the purge operation.

Illustration 3-6: Purging an empty vessel or reactor containing solvent vapors.

A 2,000 gallon reactor vessel was cooled to 20°C and the contents, an acetone solvent, were pumped out leaving only vapors. If this vessel is then purged with 1,000 standard cubic feet of nitrogen at 20°C, how much acetone is in the vented nitrogen?

Step 1. Determine the initial partial pressure of acetone in the vessel gas space.

$$p_{\text{acetone}, 20^\circ\text{C}} = \exp\left(16.6513 - \frac{2940.46}{293.15 - 35.93}\right) = \exp(5.2196) = 184.86 \text{ mmHg}$$

$$F \cdot t = (1000 \text{ scf}) \left(\frac{273.15 + 20}{273.15} \right) = 1073 \text{ acf}$$

$$V = \frac{2000 \text{ gal}}{7.48 \text{ gal / ft}^3} = 267 \text{ ft}^3$$

$$n = \frac{F \cdot t}{V} = \frac{1073 \text{ acf}}{267 \text{ ft}^3} = 4.02$$

Step 2. Calculate the acetone loss from the vessel by conducting a material balance around the vessel.

Where N_{acetone} is the amount of acetone displaced from the vessel:

$$E_{n-i} = \frac{p_{i,1} V}{RT} \left(1 - e^{-Ft/V} \right)$$

$$E_{n-i} = \frac{(184.86)(267)}{(998.9)(293.15)} \left(1 - e^{-4.02} \right)$$

$$E_{n-\text{acetone}} = (0.1686) \left(1 - e^{-4.02} \right) = (0.1686)(0.9821) = 0.166 \text{ lb - moles}$$

$$E_{\text{wt-acetone}} = (0.166 \text{ lb - moles})(58.08 \text{ lb / lb - mole}) = 9.58 \text{ lb}$$

Step 3. Calculate the amount of nitrogen emitted from the vessel.

Before the empty vessel purge began, the gas space was saturated with acetone vapors at a partial pressure of 184 mm Hg. At the completion of the purge operation, the acetone partial pressure has been reduced to 3.32 mm Hg. The amount of nitrogen that leaves the vessel through the vent is equal to the inlet amount minus the accumulation amount.

$$E_{n-\text{nitrogen}}(\text{out}) = N_{\text{nitrogen}}(\text{in}) - N_{\text{nitrogen}}(\text{accum.})$$

$$E_{n-\text{nitrogen}}(\text{out}) = \frac{PV_{\text{purge}}}{RT} - \frac{(p_{i,1} - p_{i,2})V_{\text{vessel}}}{RT}$$

$$E_{n-\text{nitrogen}}(\text{out}) = \frac{(760)(1073)}{(998.9)(293.15)} - \frac{(184.86 - 3.32)(267)}{(998.9)(293.15)} = 2.62 \text{ lb - moles}$$

$$E_{wt-nitrogen} = (2.62lb - moles)(28lb / lb - mole) = 73.4lb$$

3.2.2 Purge or Gas Sweep – Partially Filled Vessel

Air or another non-condensable gas is directed into the vessel at a controlled rate. The discharge vapors from the vessel during this operation are normally assumed to be at equilibrium or saturated with the vessel's liquid contents within certain flow rate criteria. Further, it is assumed that the inlet purge rate is known. Eq. 3-8 is used to calculate amounts of condensable components. The mixing factor S_i represents the degree of VOC saturation for the vent gas, and it is normally between 0 and 1.0. A value of 0.25 for S_i implies that the exit vent gas is at 25% saturation level with respect to the solvent vapors in the tank, while a S_i value of 1.0 implies that the exit vent gas is at equilibrium with the volatile contents of the vessel. [Hatfield, 2003a]

$$E_{R-i} = E_{R-nc} \frac{S_i p_i^{sat}}{p_{nc}^{sat}} \quad \text{Eq. 3-8}$$

Where E_{R-i} = moles of volatile component i emitted per unit time,

S_i = saturation level of the exit vent gas stream,

E_{nc} = moles of non-condensable gas emitted per unit time (= inlet purge rate),

p_i^{sat} = partial pressure of component i at saturated conditions,

p_{nc}^{sat} = partial pressure of the non-condensable gas (i.e., air, nitrogen) at saturated solvent pressure conditions.

The saturation factor for a solvent vapor is a function of the evaporation mass transfer coefficient K_i , the liquid surface area in the vessel, and the solvent partial pressure in the vessel headspace. When the exit emission rate for a vessel is set equal to the evaporation rate in the vessel then the following expression results for the saturation level S_i .

$$\text{Saturation level } S_i: \quad S_i = \frac{p_i}{p_i^{sat}} = \frac{K_i A}{K_i A + F} = \frac{K_i A}{K_i A + F_{nc} + S_i F_i^{sat}} \quad \text{Eq. 3-9}$$

$$\text{Where} \quad K_i = K_o \left(\frac{M_o}{M_i} \right)^{1/3}, \quad \text{Eq. 3-10}$$

$$\text{and} \quad F_i^{sat} = F_{nc} \frac{p_i^{sat}}{p_{nc}^{sat}} = F_{nc} \left(\frac{p_i^{sat}}{P_{sys} - p_i^{sat}} \right). \quad \text{Eq. 3-11}$$

S_i = saturated vapor pressure for compound i ,

K_i = mass transfer coefficient i ,

K_o = mass transfer coefficient of a reference compound,

M_i = molecular weight of compound i ,

M_o = molecular weight of the reference compound o ,

A = surface area of the liquid,

F_{nc} = volumetric flow rate of the non-condensable gas (i.e. air, nitrogen),

F_i^{sat} = volumetric flow rate of component i (i.e. VOC) at saturated vapor pressure,

p_i^{sat} = saturated vapor pressure of component i ,

p_{nc}^{sat} = partial pressure of the noncondensable gas (i.e. air, nitrogen) at saturated solvent pressure conditions,

P_{sys} = system pressure.

The saturated partial volumetric flow rate for each component is estimated from the component saturated vapor pressure, the inlet gas purge rate, and the partial pressure of the non-condensable at saturated conditions.

S_i may be solved using the standard quadratic solution. Although the standard quadratic equation contains two roots, only the one solution shown in Eq. 3-12 produces a realistic value since S_i must be a positive number between 0 and 1.0.

$$\text{Quadratic solution: } S_i = \frac{-(K_i A + F_{nc}) + \sqrt{(K_i A + F_{nc})^2 + 4F_i^{sat} K_i A}}{2F_i^{sat}} \quad \text{Eq. 3-12}$$

Finally, the emission rate for the volatile component i may be calculated using Eq. 3-13 which allows for the use of S_i , where $p_i = S_i p_i^{sat}$.

$$E_i = \frac{M_i S_i F_i^{sat} P_{sys}}{RT} \quad \text{Eq. 3-13}$$

For multi-component liquid mixtures, Eq. 3-9 may be expanded to provide partial volumetric flow levels for each volatile component in the liquid.

$$S_{i+1} = \frac{K_i A}{K_i A + F_{nc} + S_i F_i^{sat} + S_j F_j^{sat} + \dots + S_n F_n^{sat}} \quad \text{Eq. 3-14}$$

where i is the compound for which the saturation level is being calculated, and terms j through n represent the other components in the liquid. Eq. 3-14 is solved in an iterative trial and error manner with the initial value of S for each component assigned to 1.0. The value of S that is calculated for each component is then used as the starting point for the next iteration. Finally, when the saturation level S of each compound remains the same for subsequent iterations then the calculation process is stopped.

Emission rates for each solvent compound are then calculated based on the partial volumetric flow rate as calculated from the saturation level and the saturated volumetric flow rate $F_i = S_i F_i^{sat}$.

$$\text{Solvent emission rate } E_i = \frac{M_i S_i F_i^{sat} P_{sys}}{RT} \quad (\text{wt per unit of time})$$

Illustration 3-7: Gas sweep with a vessel containing with a single volatile solvent.

A vertical process vessel with a 6-ft cross sectional diameter is at 1 atm pressure and contains a volume of heptane at 25°C. The vessel is being purged with 10 scfm (standard cubic feet per minute) of nitrogen gas. Calculate the emission rate of heptane during the purge operation.

The molecular weight of heptane is 100.2. The mass transfer coefficient is estimated using Eq. 3-10 with the known mass transfer coefficient for water of 0.83 cm/s. Other variables are also calculated from established relationships.

$$K_i = K_o \left(\frac{M_o}{M_i} \right)^{1/3} = 0.83 \frac{\text{cm}}{\text{s}} \left(\frac{18.02}{100.2} \right)^{1/3} = 0.4685 \frac{\text{cm}}{\text{s}} \times \frac{60 \cdot \text{s} \cdot \text{ft}}{30.48 \cdot \text{min} \cdot \text{cm}} = 0.92 \frac{\text{ft}}{\text{min}}$$

$$P_{\text{heptane}}^{\text{sat}} = 45.86 \text{ mmHg}. \quad P_{\text{nitrogen}}^{\text{sat}} = 760 - 45.86 = 714.14 \text{ mmHg}.$$

$$F_{\text{nitrogen}} = 10 \text{ scfm} \frac{298.15^\circ \text{K}}{273.15^\circ \text{K}} = 10.92 \text{ ft}^3 / \text{min}$$

$$F_{\text{heptane}}^{\text{sat}} = 10.92 \frac{45.86 \text{ mmHg}}{714.14 \text{ mmHg}} = 0.70 \text{ ft}^3 / \text{min}$$

$$A = \frac{\pi d^2}{4} = \frac{3.14 * 36 \text{ ft}^2}{4} = 28.26 \text{ ft}^2$$

$$S_{\text{heptane}} = \frac{-(0.92 * 28.26 + 10.92) + \sqrt{(0.92 * 28.26 + 10.92)^2 + 4 * 0.70 * 0.92 * 28.26}}{2 * 0.70}$$

$$S_{\text{heptane}} = \frac{-36.92 + \sqrt{1363.0 + 72.79}}{1.40} = \frac{0.97}{1.40} = 0.69$$

$$E_m = \frac{M_i S_i F_i^{\text{sat}} P_{\text{sys}}}{RT_L} = \frac{(100.2 \text{ lb} / \text{lb} - \text{mole})(0.69)(0.70 \text{ ft}^3 / \text{min})(760 \text{ mmHg})}{(554.98 \text{ ft}^3 \text{ atm} / \text{lb} - \text{mol}^\circ \text{R})(537^\circ \text{R})}$$

$$E_{R-m} = 0.12 \text{ lb} / \text{min} = 7.2 \text{ lb} / \text{hr}$$

As an illustration on how the saturation factor for heptane could have been calculated using the iteration technique Eq 3-14 can be applied directly.

$$S_i = \frac{K_i A}{K_i A + F_{nc} + S_i F_i^{\text{sat}}} = \frac{0.92 * 28.26}{0.92 * 28.26 + 10.92 + S_i 0.70} = \frac{25.99}{36.92 + 0.7 * S_i}$$

Starting with an initial guess for S_i to equal 1.0, the convergence occurs rapidly with the final result 0.69 being equal to earlier results using the quadratic equation.

Iteration 0	$S_i = 1.00$
Iteration 1	$S_i = f(1.00) = 0.69$
Iteration 2	$S_i = f(0.69) = 0.69$

Illustration 3-8: Gas sweep with a vessel containing with a volatile solvent mixture.

Suppose the vessel featured in Illustration 7 contained a solvent mixture consisting of 20% heptane, 70% toluene, and 10% methanol. Assuming that the composition is specified in mole percents, calculate the

saturation factor for each component using Eq. 3-14. Before applying Eq. 3-14 to this solution several values must be calculated for each component as shown in the following table:

Table 3-1. Calculated Values for Use in Eq. 3-14

Compound	MWt	VP@25C	Mole fraction	Vp	Fi(sat)	Ki	KiA
Heptane	100.21	45.86	0.2	9.17	0.14	0.47	13.24
Toluene	92.13	28.44	0.7	19.91	0.30	0.48	13.62
Methanol	32.04	126.88	0.1	12.69	0.19	0.69	19.36

The calculated values in Table 3-1 are then substituted into Eq. 3-14 for an iterative trial and error procedure.

$$S_{i+1} = \frac{K_i A}{K_i A + F_{nc} + S_i F_i^{sat} + S_j F_j^{sat} + \dots + S_n F_n^{sat}} \quad \text{Eq. 3-14}$$

Table 3-2. Iterative Trial and Error Results for Si using Eq. 3-14

Compound	KiA	FiSat	Si (iteration 0)	Si (iteration 1)	Si (iteration 2)	Si (iteration 3)
Heptane	13.24	0.14	1.00	0.53	0.54	0.54
Toluene	13.62	0.30	1.00	0.54	0.55	0.55
Methanol	19.36	0.19	1.00	0.63	0.63	0.63

Finally, the solvent emission rate for each component may be calculated from the relationship.

$$Q_i = \frac{M_i S_i F_i^{sat} P_{sys}}{RT} \quad (\text{weight per unit of time})$$

to produce the following emission rate results.

Table 3-3. Calculated Emission Rates

Compound	MWt	Si	FiSat	Qi (lb/min)	Qi (lb/hr)
Heptane	100.21	0.54	0.14	0.0192	1.15
Toluene	92.13	0.55	0.30	0.0389	2.33
Methanol	32.04	0.63	0.19	0.0100	0.60

3.3 Vacuum Operations

The application of vacuum is used in many distillation or drying operations as a means of reducing the boiling point temperature of a given process mixture. In the case of vacuum distillation, solvent is vaporized in the still vessel, condensed at a low temperature, and collected in a receiving vessel. In the case of a solids drying operation, wet product cake is placed in a rotary or tray dryer and vacuum is applied to the entire drying system. Heat is then applied to the dryer and solvent vapors are condensed at a low temperature and collected in the receiving vessel.

Vent emissions that occur from vacuum operations are the result of air being removed from the system by the vacuum pump or ejector. For solids drying, a nitrogen sweep may be applied at the dryer as a means of accelerating the drying process. The vacuum pump or ejector must remove this additional nitrogen along with any air that has leaked into the system due to the lower pressure.

When the initial distillation phase is underway then the vent emissions are calculated for the system as being from the distillate receiver based on the condensate volume, composition, and temperature. Additionally, the non-condensable gas flow rate (air leak rate and/or nitrogen) and operating vacuum level must be taken into account. It is assumed that the exiting vent gas from the vacuum receiver is saturated with vapors from the liquid condensate.

The moles of each volatile component in the exit vent gas are calculated using the following relationship.

$$E_{n-i} = E_{n-nc} \frac{P_i}{P_{nc}} \quad \text{Eq. 3-15}$$

Where E_{n-i} = moles of volatile component i emitted from the process,

E_{n-nc} = total moles of noncondensable gas emitted from the process,

p_i = partial pressure of volatile component i ,

p_{nc} = partial pressure of the noncondensable gas (i.e. air, nitrogen) at saturated solvent pressure conditions.

E_{n-nc} represents the total moles of non-condensable gas component that are removed from the system by the vacuum pump.

$$E_{n-nc} = E_{n-nc-leakage} + E_{n-nc-displacement} + E_{n-nc-gas\ sweep} \quad \text{Eq. 3-16}$$

Where $E_{n-nc-leakage}$ are the moles of air due to leakage into the system,

$E_{n-nc-displacement}$ are the moles of air that are displaced by the condensate,

$E_{n-nc-gas\ sweep}$ are the moles of air or nitrogen admitted as a gas sweep.

If the distillation phase has been completed and the receiver continues to hold condensate while remaining under vacuum, then the non-condensable gas flow rate is based on the air leak rate and/or any nitrogen sweep flow that might exist.

In many cases the air leak rate might be expressed in acfm (ft³/min at actual temperature and pressure conditions) because it relates to either a known vacuum pump capacity at the 25 mm Hg condition or may have been measured through prior vacuum leak test on the equipment. The nitrogen gas sweep is normally specified in scfm (ft³/min at standard temperature and pressure conditions) because it relates to nitrogen gas flow meter that might be used for control purposes.

Illustration 3-9: Vacuum operation with vessel filling.

400 gallons of toluene are distilled from a process mixture under vacuum conditions in 2.5 hours. The equipment consists of a 1000 gallon still, condenser, and 1000 gallon receiver. A liquid ring vacuum is used to reduce the operating pressure of the equipment system to 100 mm Hg. The air leak rate is known to be 10 acfm at these conditions. The condenser is cooled with 5°C chilled glycol and the toluene condensate is measured to be 10°C. Calculate the vent emissions leaving the equipment system.

For this problem, toluene is being collected at 10°C in the receiver and an air leak rate has been specified.

Air leak rate:	10 acfm.
Receiver displacement volume:	400 gallons
Operating pressure:	100 mm Hg.
Vapor pressure of toluene at 10°C:	12.43 mm Hg. Antoine equation
Process time:	2.5 hours

Calculations:

Partial pressure of non-condensable: $P_{nc} = 100 \text{ mm Hg} - 12.43 \text{ mm Hg} = 87.57 \text{ mm Hg}$.

Displacement volume in ft^3 :

$$V = \frac{400 \text{ gal}}{7.485 \text{ gal / ft}^3} = 53.44 \text{ ft}^3$$

$$E_{n-nc-displacement} = \frac{p_{nc}V}{RT_{sys}} = \frac{87.57 \text{ mmHg} \cdot 53.44 \text{ ft}^3}{(998.9)(293.15 \text{ K})} = 0.25 \text{ lb - moles}$$

Leakage volume in ft^3 :

$$V_{leakage} = (10 \text{ acfm})(2.5 \text{ hr})(60 \text{ min / hr}) = 1560 \text{ ft}^3$$

$$E_{n-nc-leakage} = \frac{p_{nc}VT_m}{RT_{\circ K}} = \frac{100 \text{ mmHg} \cdot 1560 \text{ ft}^3}{(998.9)(293.15 \text{ K})} = 0.53 \text{ lb - moles}$$

Therefore

$$E_{n-nc} = E_{n-nc-leakage} + E_{n-nc-displacement} + E_{n-nc-gas \text{ sweep}}$$

$$E_{n-nc} = 0.53 \text{ lb - moles} + 0.25 \text{ lb - moles} + 0 \text{ lb - moles} = 0.78 \text{ lb - moles}$$

Finally

$$E_{n-toluene} = E_{n-nc} \frac{p_i}{p_{nc}} = 0.78 \frac{12.47}{87.57} = 0.11 \text{ lb - moles}$$

$$E_{wt-toluene} = E_{n-toluene} M_{w_{toluene}} = (0.11 \text{ lb - moles})(92.13 \text{ lb / lb - mole}) = 10.23 \text{ lb}$$

Illustration 3-10: Vacuum operation without vessel filling.

100 gallons of toluene have been collected from a product solids drying operation. The equipment consists of a 200 ft^3 tray drier, condenser, and 250 gallon receiver. A liquid ring vacuum is used to maintain an operating pressure of 25 mm Hg. The air leak rate is known to be 1 acfm under these conditions. For this final phase of the drying operation a 1 scfm nitrogen gas sweep is applied to the tray dryer to help accelerate the final drying phase. Although the distillation phase of the operation has ended, the recovered toluene remains in the receiver and is maintained at 7°C. Calculate the toluene emissions from the equipment system to the vacuum pump over a 1.0 hour period.

Since the distillation phase has ended the only the air leak rate and nitrogen gas sweep rate need to be considered.

Air leak rate: 1 acfm.

Nitrogen gas sweep rate: 1 scfm
 Operating pressure: 25 mm Hg.
 Vapor pressure of toluene at 7°C: 10.40 mm Hg. Antoine equation

Calculations:

Leakage (air):

$$V_{leakage} = (1 \text{ acfm})(60 \text{ min}) = 60 \text{ ft}^3$$

$$E_{n-nc-leakage} = \frac{P_{nc} V T_m}{R T_{\circ K}} = \frac{25 \text{ mmHg} \cdot 60 \text{ ft}^3}{(998.9)(280.15^\circ K)} = 0.0054 \text{ lb} - \text{moles}$$

Gas sweep (nitrogen):

$$V_{gas \text{ sweep}} = (1 \text{ scfm})(60 \text{ min}) = 60 \text{ ft}^3 (\text{stp})$$

$$E_{n-nc-gas \text{ sweep}} = \frac{P_{stp} V}{R T_{stp}} = \frac{760 \text{ mmHg} \cdot 60 \text{ ft}^3}{(998.9)(273.15^\circ K)} = 0.17 \text{ lb} - \text{moles}$$

Therefore

$$E_{n-nc} = E_{n-nc-leakage} + E_{n-nc-displacement} + E_{n-nc-gas \text{ sweep}}$$

$$E_{n-nc} = 0.0054_{n-nc-leakage} + 0_{n-nc-displacement} + 0.17_{n-nc-gas \text{ sweep}} = 0.18 \text{ lb} - \text{moles}$$

Finally

$$P_{nc} = P_{sys} - P_{toluene} = 25.0 - 10.4 = 14.6 \text{ mmHg}$$

$$E_{n-toluene} = E_{n-nc} \frac{P_i}{P_{nc}} = 0.18 \frac{10.40}{14.60} = 0.13 \text{ lb} - \text{moles}$$

$$E_{wt-toluene} = E_{n-toluene} M_{w_{toluene}} = (0.13 \text{ lb} - \text{moles})(92.13 \text{ lb/lb} - \text{mole}) = 11.98 \text{ lb}$$

3.4 Gas Evolution

Certain processes generate off gases as function of the reaction chemistry. Vent emissions from these types of operations may be estimated by assuming that the exit vent off gas containing the reaction off gas is fully saturated with vapors from the volatile components in the batch. The partial pressure of each component is calculated based on the pure component vapor pressure, mixture composition, and any non-idealities that might exist (activity coefficients).

The moles of each volatile component in the exit vent gas are calculated using the following relationship.

$$E_{n-i} = E_{n-rxn} \frac{P_i}{P_{rxn}} \quad \text{Eq. 3-17}$$

where: E_{n-i} = moles of volatile component i emitted from the process,

E_{n-rxn} = total moles of reaction off gas emitted from the process,

P_i = partial pressure of volatile component i ,

P_{rxn} = partial pressure of the noncondensable gas (i.e. air, nitrogen) at saturated solvent pressure conditions.

The stoichiometric amount of off gas is usually determined by the process chemistry. However, other considerations may need to be taken into account when estimating the actual amount of off gas that leaves the system. For example, if the off gas is partially soluble in the process solvent then the portion that does not dissolve in the batch will exit the vessel through the vent. If the solubility of the off gas is not known the one could conservatively assume that 100% of the reaction off gas exits the process through the vessel vent.

Illustration 3-11: Reaction involving a gas evolution of one component.

A reaction takes place in a vessel at 50°C with toluene as the primary solvent. Eight pounds of hydrogen chloride is generated based on the chemistry and vented out of the vessel over a one-hour period. Calculate the compound emissions that occur from the reaction, if the system pressure is 760 mm Hg. Also, assume that the batch consist of 95% toluene (mole/mole) and 5% compounds that are nonvolatile.

Step 1. Determine the hydrogen chloride that is discharged from the vessel.

$$E_{n-HCl} = \frac{Wt_{HCl}}{MWt_{HCl}} = \frac{8 \text{ lbs}}{36.461 \text{ lb/lb-mole}} = 0.219 \text{ lb-mole}$$

Step 2. Calculate the vapor pressure of toluene at 50°C using the Antoine equation.

$$P_{\text{toluene}, 50^\circ C} = \exp\left(16.0137 - \frac{3096.52}{323.15 - 53.67}\right) = \exp(4.52298) = 92.11 \text{ mmHg}$$

$$P_{\text{toluene}, 50^\circ C} = 0.95 \times 92.11 \text{ mmHg} = 87.50 \text{ mmHg}$$

Step 3. Calculate the toluene emission rate by the ratio of vapor pressures.

$$E_{n\text{-toluene}} = E_{HCl} \left(\frac{P_{\text{toluene}}}{P_{HCl}} \right)$$

$$E_{n\text{-toluene}} = 0.219 \text{ lb-moles} \left(\frac{87.50 \text{ mmHg}}{760 \text{ mmHg} - 87.50 \text{ mmHg}} \right) = 0.0285 \text{ lb-moles}$$

$$E_{wt\text{-toluene}} = 0.0285 \text{ lb-moles} \times 92.13 \text{ lb/lb-mole}$$

$$E_{wt\text{-toluene}} = 2.63 \text{ lbs}$$

Illustration 3-12: Reaction involving gas evolution of two components.

A reaction takes place in a vessel at 50°C with toluene as the primary solvent. Eight pounds of hydrogen chloride along with an equal molar quantity of sulfur dioxide is generated and vented out of the vessel over a one-hour period. Calculate the compound emissions that occur from the reaction, if the system pressure is 760 mm Hg. Also, assume that the batch consist of 95% toluene (mole/mole) and 5% compounds that are nonvolatile.

Step 1. Determine the hydrogen chloride and sulfur dioxide that is discharged from the vessel.

The molar amount of HCl is calculated from the molecular weight and the quantity of HCL emitted. The molar amount of SO₂ is set equal to the calculated molar amount of HCl.

$$E_{n-HCl} = \frac{Wt_{HCl}}{MWt_{HCl}} = \frac{8 \text{ lbs}}{36.461 \text{ lb/lb-mole}} = 0.219 \text{ lb-mole}$$

$$E_{n-SO_2} = n_{HCl} = 0.219 \text{ lb - moles}$$

$$E_{wt-SO_2} = 0.219 \text{ lb - moles} \times 64.063 \text{ lb/lb - mole} = 14.03 \text{ lbs}$$

Step 2. Calculate the vapor pressure of toluene at 50°C using the Antoine equation.

$$P_{\text{toluene}, 50^\circ C} = \exp\left(16.0137 - \frac{3096.52}{323.15 - 53.67}\right) = \exp(4.52298) = 92.11 \text{ mmHg}$$

$$p_{\text{toluene}, 50^\circ C} = 0.95 \times 92.11 \text{ mmHg} = 87.50 \text{ mmHg}$$

Step 3. Calculate the toluene emission rate by the ratio of vapor pressures.

$$E_{n\text{-toluene}} = \left(\frac{P_{\text{toluene}}}{P_{HCl} + P_{SO_2}}\right)(n_{HCl} + n_{SO_2}) = \left(\frac{P_{\text{toluene}}}{P_{\text{sys}} - p_{\text{toluene}}}\right)(n_{HCl} + n_{SO_2})$$

$$E_{n\text{-toluene}} = \left(\frac{87.50 \text{ mmHg}}{760 \text{ mmHg} - 87.50 \text{ mmHg}}\right) 0.438 \text{ lb - mole} = 0.057 \text{ lb - moles}$$

$$E_{wt\text{-toluene}} = 0.057 \text{ lb - moles} \times 92.13 \text{ lb / lb - mole}$$

$$E_{wt\text{-toluene}} = 5.26 \text{ lbs}$$

$$E_{wt\text{-HCl}} = 8.0 \text{ lbs}$$

$$E_{wt\text{-SO}_2} = 14.03 \text{ lbs}$$

Illustration 3-13: Reaction involving multicomponent gas evolution and nitrogen purge.

A reaction takes place over a 1.0 hour period in a vessel at 50°C with toluene as the primary solvent. Eight pounds of hydrogen chloride along with an equal molar quantity of sulfur dioxide is generated and vented out of the vessel over a one-hour period. Calculate the compound emissions that occur from the reaction, if the system pressure is 760 mm Hg and a nitrogen purge is being applied at 30 SCFH. Also, assume that the batch consist of 95% toluene (mole/mole) and 5% compounds that are nonvolatile.

Step 1. Determine the hydrogen chloride, sulfur dioxide, and nitrogen that are discharged from the vessel over the one hour period. The molar amount of HCl is calculated from the molecular weight and the quantity of HCL emitted. The molar amount of SO₂ is set equal to the calculated molar amount of HCl.

$$E_{n\text{-HCl}} = \frac{Wt_{HCl}}{MWt_{HCl}} = \frac{8 \text{ lbs}}{36.461 \text{ lb / lb - mole}} = 0.219 \text{ lb - mole}$$

$$E_{n\text{-SO}_2} = n_{HCl} = 0.219 \text{ lb - moles}$$

$$E_{wt\text{-SO}_2} = 0.219 \text{ lb - moles} \times 64.063 \text{ lb / lb - moles} = 14.03 \text{ lbs}$$

The molar amount of N₂ is calculated based on the 30 SCFH (standard cubic feet per hour) flow rate or nitrogen for the 1.0 hour reaction period.

$$E_{n-N_2} = \frac{30.0 \text{ SCFH} \times 1.0 \text{ HR}}{359.046 \text{ SCF/lb-mole}} = 0.084 \text{ lb-mole}$$

$$E_{wt-N_2} = 0.084 \text{ lb-moles} \times 28.013 \text{ lb/lb-moles} = 2.35 \text{ lbs}$$

The total moles of non-condensable compounds are calculated by summing the molar amounts of HCl, SO₂, and N₂.

$$E_{n-nc} = E_{n-HCl} + E_{n-SO_2} + E_{n-N_2} = 0.219 + 0.219 + 0.084$$

$$E_{n-nc} = 0.522 \text{ lb-moles}$$

Step 2. Calculate the vapor pressure of toluene at 50°C using the Antoine equation.

$$P_{\text{toluene}, 50^\circ\text{C}} = \exp\left(16.0137 - \frac{3096.52}{323.15 - 53.67}\right) = \exp(4.52298) = 92.11 \text{ mmHg}$$

$$p_{\text{toluene}, 50^\circ\text{C}} = 0.95 \times 92.11 \text{ mmHg} = 87.50 \text{ mmHg}$$

Step 3, Calculate the toluene emission rate by the ratio of vapor pressures.

$$E_{n\text{-toluene}} = \left(\frac{P_{\text{toluene}}}{\sum P_{nc}}\right) E_{n-nc} = \left(\frac{P_{\text{toluene}}}{P_{\text{sys}} - P_{\text{toluene}}}\right) E_{n-nc}$$

$$E_{n\text{-toluene}} = \left(\frac{87.50 \text{ mmHg}}{760 \text{ mmHg} - 87.50 \text{ mmHg}}\right) 0.522 \text{ lb-mole} = 0.13 \text{ lb-moles}$$

$$E_{wt\text{-toluene}} = 0.13 \text{ lb-moles} \times 92.13 \text{ lb/lb-mole}$$

$$E_{wt\text{-toluene}} = 11.98 \text{ lbs}$$

$$E_{wt\text{-HCl}} = 8.0 \text{ lbs}$$

$$E_{wt\text{-SO}_2} = 14.03 \text{ lbs}$$

$$E_{wt\text{-N}_2} = 2.35 \text{ lbs}$$

3.5 Depressurization

Estimating solvent emissions from the depressurization of a batch pressure filter for solids discharge or for the evacuation of a vessel that contains a volatile liquid mixture and a noncondensable gas-phase component, such as air or nitrogen, requires certain assumptions and approximations be made:

- The system pressure is decreased linearly over time.
- Air leakage into the vessel during the operation is negligible.
- The liquid and gas space temperature remains constant during the operation.
- The vapor space of the vessel remains in equilibrium with the volatile liquid contents during the depressurization process.

Since the system temperature is assumed to remain constant during the depressurization operation then the equilibrium vapor pressure of the vessel liquid contents remains constant as well. The moles of solvent vapor that exist within the vessel headspace during the depressurization remain constant for this reason. However, the volatile solvent vapor occupies a greater fraction of the vessel headspace and exit vent gas as the depressurization takes place since the system pressure is being reduced toward the solvent vapor pressure level. As the depressurization unfolds then more and more solvent must evaporate in order to maintain the equilibrium vapor pressure. Therefore, the solvent emissions that occur during depressurization are equal to the net solvent evaporation within the vessel, based on the assumptions for this model.

Eq. 3-18 is based on a material balance for the non-condensable in the vessel headspace and the assumption that the total system pressure is equal to the partial pressure of the volatile plus the partial pressure of the non-condensable. Eq. 3-18 may be integrated as shown in Eq. 3-19 to result in Eq. 3-20. [Hatfield, 1998b]

$$dn_i(out) = -\left(\frac{V}{RT}\right) \frac{p_i}{p_{nc}} dp_{nc} \quad \text{Eq. 3-18}$$

$$\int_{p_1}^{p_2} dn_i(out) = -\left(\frac{Vp_i}{RT}\right)_{T,V} \int_{p_1}^{p_2} \frac{dp_{nc}}{p_{nc}} \quad \text{Eq. 3-19}$$

$$n_{i,out} = \frac{Vp_i}{RT} \ln\left(\frac{p_{nc,1}}{p_{nc,2}}\right) \quad \text{Eq. 3-20}$$

Where: $n_{i,out}$ = moles of volatile component i leaving the vessel

V = vessel headspace volume

p_i = partial pressure of the volatile component

R = Universal gas constant

T = system temperature

$p_{nc,1}$ = partial pressure of the non-condensable component at initial conditions

$p_{nc,2}$ = partial pressure of the non-condensable component at final conditions

Illustration 3-14: Vessel depressurization involving one volatile component.

A 1,000 gallon nutsche filter is used to compress a slurry containing acetone and nonvolatile solids at 80°F (26.7°C). A pressure of 35 psig is imparted onto the slurry until the desired filtration is achieved (approximately 40 minutes). The nutsche filter is then depressurized prior to the discharging of its contents. Residual solids in the filter are estimated to occupy 500 gallons of the filter volume.

Calculate the acetone emissions from the depressurization operation.

Given:

T	=	26.7°C	=	299.85°K	
P1	=	35 psig	=	2570 mm Hg	(Initial pressure)
P2	=	0.0 psig	=	760 mm Hg	(Final pressure)
V	=	500 gal	=	66.843 ft ³	(Gas space volume)

Step 1. Determine the saturated vapor pressure for acetone at 26.7°C and the non-condensable partial pressure at initial ($P_{nc,1}$) and final conditions ($P_{nc,2}$).

$$P_{acetone,26.7^\circ C} = \exp\left(16.6513 - \frac{2940.46}{299.85 - 35.93}\right) = \exp(5.5098) = 247.11 \text{ mmHg}$$

Therefore:

$$P_{nc,1} = (2570 - 247.11) = 2,322.89 \text{ mm Hg}$$

$$P_{nc,2} = (760 - 247.11) = 512.89 \text{ mm Hg}$$

Step 2. Calculate the amount of acetone vapor that is emitted from the depressurization operation.

$$E_{n-acetone} = \frac{Vp_i}{RT} \ln\left(\frac{P_{nc,1}}{P_{nc,2}}\right) = \frac{(66.843)(247.11)}{(998.9)(300)} \ln\left(\frac{2322.89}{512.89}\right) = 0.0827 \text{ lb-moles}$$

$$E_{wt-acetone} = (0.0827 \text{ lb-moles}) (58.08 \text{ lb/lb-mole}) = 4.8 \text{ lbs}$$

Illustration 3-15: Vessel depressurization involving a solvent mixture.

A 1,200 gallon process vessel contains 700 gallons of solvent mixture that is being prepared for vacuum distillation. The solvent mixture is at 20°C and has a molar composition of 20% acetone, 50% toluene, and 30% methanol. Calculate the emissions from the depressurization operation if the pressure is reduced from 760 mm Hg to 100 mm Hg.

Given:

$$\begin{aligned} T &= 20.0^\circ\text{C} &= 293.15^\circ\text{K} \\ P_1 &= 760 \text{ mm Hg} && \text{(Initial pressure)} \\ V &= 500 \text{ gal} &= 66.843 \text{ ft}^3 & \text{(Gas space volume)} \end{aligned}$$

$$\text{Universal Gas Constant: } R = 998.9 \frac{\text{mmHg} \cdot \text{ft}^3}{\text{lb-mole} \cdot ^\circ\text{K}}$$

$$\text{Gas Law: } n = \frac{PV}{RT}, \text{ also } n_i = \frac{p_i V}{RT} \text{ for a single component, } i, \text{ in the gas space.}$$

Step 1. Determine the saturated vapor pressure composition for the process material at 25°C.

For this illustration the equilibrium vapor pressure composition for the process mixture may be calculated based on the pure vapor pressure and mole fraction of each component in the mixture. The total saturated vapor pressure for the mixture is calculated to be 77.08 mm Hg. as shown in the following table.

Compound	Pure Vapor Pressure (mm Hg)	Mole Fraction X_i	$P_i = X_i \cdot P_i$ (mm Hg)
Acetone	184.86	0.2	36.97
Methanol	97.30	0.3	29.19
Toluene	21.84	0.5	10.92
Total			77.08

$$E_{n\text{-acetone}} = \frac{Vp_i}{RT} \ln\left(\frac{p_{nc,1}}{p_{nc,2}}\right) = \frac{(66.843)(36.97)}{(998.9)(293.15)} \ln\left(\frac{682.92}{22.92}\right) = 0.0286 \text{ lb-moles}$$

$$E_{n\text{-methanol}} = \frac{Vp_i}{RT} \ln\left(\frac{p_{nc,1}}{p_{nc,2}}\right) = \frac{(66.843)(29.19)}{(998.9)(293.15)} \ln\left(\frac{682.92}{22.92}\right) = 0.0226 \text{ lb-moles}$$

$$E_{n\text{-toluene}} = \frac{Vp_i}{RT} \ln\left(\frac{p_{nc,1}}{p_{nc,2}}\right) = \frac{(66.843)(10.92)}{(998.9)(293.15)} \ln\left(\frac{682.92}{22.92}\right) = 0.0085 \text{ lb-moles}$$

3.6 Heating

Heat-up losses that occur during the operation of reactors, distillation equipment, and similar types of processing equipment may be estimated by application of the Ideal Gas Law and vapor-liquid equilibrium principles. Emissions are calculated using the following assumptions:

The vessel is closed during the operation but vapors are vented through a process vent. Additional material is not added to the vessel during heat-up. The displaced gas is assumed to be saturated with VOC vapor in equilibrium with the process material.

When a vessel containing a volatile liquid and a noncondensable gas (e.g. air) is heated at constant pressure, the vapor space gas undergoes expansion and a portion of the gas phase leaves the vessel through the vent. Additionally, the saturated vapor pressures for the volatile liquid components increase. The calculation is based on the premise that the amount of the non-condensable component (air, nitrogen, etc.) that is displaced from the vessel is determined by the initial and final gas space composition. If a nitrogen purge or sweep is placed on the vessel during the heating step, then the amount of non-condensable component that is displaced from the vessel is increased by the total amount of purge gas that passes through the vessel during the heating.

In the heating model, rising vapors from the vessel liquid contents displace the non-condensable gas components from the headspace through the process vent. As the liquid mixture reaches the boiling point, all of the non-condensable component is purged from the vapor space. This model assumes that the average molar headspace volume remains constant relative to changes in the molar composition of the vessel headspace. Eq. 3-21 is derived from performing material balances around the vessel headspace for

the non-condensable component and for component i during the heating. [Hatfield, 1998c]

$$E_{n-i,out} = N_{avg} \ln\left(\frac{p_{nc,1}}{p_{nc,2}}\right) - (n_{i,2} - n_{i,1})_{vessel} \quad \text{Eq. 3-21}$$

Where:
$$N_{avg} = \frac{1}{2}(n_1 + n_2)$$
 Eq. 3-22

$n_{i,out}$ = moles of volatile component i leaving the vessel process vent

N_{avg} = average gas space molar volume during the heating process

p_{nc1} = partial pressure of non-condensable in the vessel headspace at temperature T_1

p_{nc2} = partial pressure of non-condensable in the vessel headspace at temperature T_2

$n_{i,1}$ = moles of volatile component i in the vessel headspace at temperature T_1

$n_{i,2}$ = moles of volatile component i in the vessel headspace at temperature T_2

n_1 = total moles of gas in the vessel headspace at temperature T_1

n_2 = total moles of gas in the vessel headspace at temperature T_2

Illustration 3-16: Heatup losses from a vessel containing a single volatile component.

A 1250 gallon reactor containing 750 gallons of a toluene solution is heated from 20°C to 70°C. The reactor is vented to the atmosphere during the heat up. How much toluene will be emitted?

Step 1. Calculate the average molar volume of the vessel headspace.

T_i	=	20°C	=	293.15°K	(Initial temperature)
T_f	=	70°C	=	343.15°K	(Final temperature)
P_T	=	1.0 atm	=	760 mm Hg	(Total system pressure)
V_{gas}	=	500 gallons	=	66.843 ft ³	(Gas space volume)
R	=	998.9 (mmHg-ft ³)/(lb-mole-°K)			(Universal gas constant)

Gas Law: $n = \frac{PV}{RT}$, also $n_i = \frac{p_i V}{RT}$ for a single component, i , in the gas space.

$$N_{avg} = \frac{1}{2}(n_1 + n_2)$$

$$N_{avg} = \frac{1}{2} \left[\left(\frac{PV}{RT} \right)_1 + \left(\frac{PV}{RT} \right)_2 \right] = \frac{760 \times 66.843}{2 \times 998.9} \left(\frac{1}{293.15} + \frac{1}{343.15} \right) = 0.1608 \text{ lb-moles}$$

Step 2. Calculate the initial and final partial pressures of nitrogen.

Use the Antoine equation to calculate the partial pressure of toluene:

$$P_{toluene, 20^\circ C} = \exp \left(16.0137 - \frac{3096.52}{293.15 - 53.67} \right) = \exp(3.0835) = 21.84 \text{ mmHg}$$

$$P_{toluene, 70^\circ C} = \exp \left(16.0137 - \frac{3096.52}{343.15 - 53.67} \right) = \exp(5.317) = 203.74 \text{ mmHg}$$

The partial pressure of nitrogen is the difference between the total system pressure and the partial pressure of toluene:

$$p_{nc,1} = 760 - p_{toluene,1} = 760 - 21.84 = 738.16 \text{ mmHg}$$

$$p_{nc,2} = 760 - p_{toluene,2} = 760 - 203.74 = 556.26 \text{ mmHg}$$

Step 3. Calculate the initial and final number of moles of toluene in the vessel headspace.

Use the Gas Law to calculate the moles of toluene:

$$n_{\text{toluene},1} = \left(\frac{P_{\text{toluene},1}V}{RT_1} \right) = \frac{21.84 \times 66.843}{998.9 \times 293.15} = 0.00499 \text{ moles}$$

$$n_{\text{toluene},2} = \left(\frac{P_{\text{toluene},2}V}{RT_2} \right) = \frac{203.74 \times 66.843}{998.9 \times 343.15} = 0.0397 \text{ moles}$$

Step 4. Calculate the toluene emission using Eq. 3-21.

The moles of toluene that are displaced from the vessel are calculated by substituting values that have been calculated prior to this point into Eq. 3-21.

$$E_{n-i} = N_{\text{avg}} \ln \left(\frac{p_{nc,1}}{p_{nc,2}} \right) - (n_{i,2} - n_{i,1})_{\text{vessel}}$$

$$E_{n\text{-toluene}} = (0.1608) \ln \left(\frac{738.16}{556.26} \right) - (0.0397 - 0.00499) = 0.0108 \text{ lb - moles}$$

$$E_{\text{wt-toluene}} = (0.0108 \text{ lb - moles})(92.13 \text{ lb / lb - mole}) = 0.995 \text{ lbs}$$

Illustration 3-17: Heatup losses from a vessel containing a volatile mixture.

A 2000 gallon reactor contains 1,500 gallons of a solvent mixture. The solvent mixture has a molar composition of 60% toluene, 30% methyl ethyl ketone, and 10% methylene chloride.

The solvent mixture is heated from 20°C to 70°C and the reactor is vented to atmosphere (760 mm Hg) during the heat up operation. How much of each component will be emitted from the process?

Step 1. Calculate the gas space partial pressure for each compound in the liquid using Raoult's Law and residual partial pressure of nitrogen.

Table 3-4. Partial Pressure Calculates for 20°C and 70°C

Compound	X _i	P _i @ 20C (mm Hg)	X _i P _i (20C) (mm Hg)	P _i @ 70C (mm Hg)	X _i P _i (70C) (mm Hg)
Toluene	0.60	21.835	13.101	203.74	122.25
Methyl Ethyl Ketone	0.30	74.908	22.472	555.52	166.66
Methylene Chloride	0.10	355.540	35.554	2005.2	200.52
Totals	1.00		71.127		489.43

			(mm Hg)		(mm Hg)
Nitrogen (Residual)			688.873		270.57

Step 2. Calculate the average gas space molar volume.

$$N_{\text{avg}} = \frac{1}{2}(n_1 + n_2)$$

$$N_{avg} = \frac{1}{2} \left[\left(\frac{PV}{RT} \right)_1 + \left(\frac{PV}{RT} \right)_2 \right] = \left(\frac{760 \times 66.843}{2 \times 998.9} \right) \left(\frac{1}{293.15} + \frac{1}{343.15} \right) = 0.1608 \text{ lb-moles}$$

Step 3. Calculate the initial and final number of moles of toluene in the vessel headspace.

Use the Gas Law to calculate the moles of toluene:

$$n_{i,1} = \left(\frac{p_{i,1}V}{RT_1} \right) = \frac{71.12 \times 66.843}{998.9 \times 293.15} = 0.01623 \text{ moles}$$

$$n_{i,2} = \left(\frac{p_{i,2}V}{RT_2} \right) = \frac{489.43 \times 66.843}{998.9 \times 343.15} = 0.09544 \text{ moles}$$

$$E_{n-i} = N_{avg} \ln \left(\frac{p_{nc,1}}{p_{nc,2}} \right) - (n_{i,2} - n_{i,1})_{vessel}$$

$$E_{n-i} = (0.1608) \ln \left(\frac{688.873}{270.57} \right) - (0.09544 - 0.01623) = 0.07106 \text{ lb-moles}$$

Table 3-5. Final Calculated Results for This Problem

Compound	avg p _i (mm Hg)	Fraction To total	n _i (lb-moles)	MW _{t_i}	wt _i (lbs)
Toluene	67.67	0.242	0.0172	92.13	1.58
Methyl Ethyl Ketone	94.566	0.337	0.0240	72.1	1.73
Methylene Chloride	118.037	0.421	0.02992	84.94	2.54
Totals	280.273	1.000	0.0687		

Illustration 3-18: Heatup losses from a vessel with a volatile mixture and nitrogen sweep.

A 1250 gallon reactor containing 750 gallons of a solution of a raw material in toluene is heated from 20°C to 70°C over a one hour period. The vessel has a known gas sweep of 3 scfm of air. The reactor is vented to the atmosphere during the heat up. Assuming a 25% vapor saturation of the gas sweep vapors, how much toluene will be emitted?

This problem differs from the prior heating illustration because we wish to take into account air or nitrogen that is entering the head space of the vessel during the operation. The basic approach used is to first calculate the vent losses of toluene and air (as in the prior example) and then calculate the total toluene losses based on the relative net change in the exit air flow rate due to the gas sweep while at the same time taking into account the saturation level.

Step 1. Calculate the average molar volume of the vessel headspace.

T _i	=	20°C	=	293.15°K	(Initial temperature)
T _f	=	70°C	=	343.15°K	(Final temperature)
P _T	=	1.0 atm	=	760 mm Hg	(Total system pressure)
V _{gas}	=	500 gal	=	66.843 ft ³	(Gas space volume)
R	=	998.9 (mmHg-ft ³)/(lb-mole-°K)			(Universal gas constant)

Gas Law: $n = \frac{PV}{RT}$, also $n_i = \frac{p_i V}{RT}$ for a single component, i , in the gas space.

$$N_{avg} = \frac{1}{2}(n_1 + n_2)$$

$$N_{avg} = \frac{1}{2} \left[\left(\frac{PV}{RT} \right)_1 + \left(\frac{PV}{RT} \right)_2 \right] = \frac{760 \times 66.843}{2 \times 998.9} \left(\frac{1}{293.15} + \frac{1}{343.15} \right) = 0.1608 \text{ lb-moles}$$

Step 2. Calculate the initial and final partial pressures of nitrogen.

Use the Antoine equation to calculate the partial pressure of toluene:

$$P_{\text{toluene}, 20^\circ\text{C}} = \exp\left(16.0137 - \frac{3096.52}{293.15 - 53.67}\right) = \exp(3.0835) = 21.84 \text{ mmHg}$$

$$P_{\text{toluene}, 70^\circ\text{C}} = \exp\left(16.0137 - \frac{3096.52}{343.15 - 53.67}\right) = \exp(5.317) = 203.74 \text{ mmHg}$$

The partial pressure of nitrogen is the difference between the total system pressure and the partial pressure of toluene:

$$p_{nc,1} = 760 - p_{\text{toluene},1} = 760 - 21.84 = 738.16 \text{ mmHg}$$

$$p_{nc,2} = 760 - p_{\text{toluene},2} = 760 - 203.74 = 556.26 \text{ mmHg}$$

Step 3. Calculate the initial and final number of moles of toluene and air in the vessel headspace.

Use the Gas Law to calculate the moles of toluene and air:

$$n_{\text{toluene},1} = \left(\frac{p_{\text{toluene},1} V}{RT_1} \right) = \frac{21.84 \times 66.843}{998.9 \times 293.15} = 0.00499 \text{ moles}$$

$$n_{nc,1} = \left(\frac{p_{nc,1} V}{RT_1} \right) = \frac{738.16 \times 66.843}{998.9 \times 293.15} = 0.1685 \text{ moles}$$

$$n_{\text{toluene},2} = \left(\frac{p_{\text{toluene},2} V}{RT_2} \right) = \frac{203.74 \times 66.843}{998.9 \times 343.15} = 0.0397 \text{ moles}$$

$$n_{nc,2} = \left(\frac{p_{nc,2} V}{RT_2} \right) = \frac{556.26 \times 66.843}{998.9 \times 343.15} = 0.1085 \text{ moles}$$

Step 4. Calculate the toluene emission using Eq. 3-21.

The number of moles of toluene displaced from the vessel is equal to the moles of nitrogen that are displaced from the vessel during the heating operation multiplied by the average molar ratio.

$$E_{n-i} = N_{avg} \ln\left(\frac{p_{nc,1}}{p_{nc,2}}\right) - (n_{i,2} - n_{i,1})_{\text{vessel}}$$

$$E_{n-\text{toluene}} = (0.1608) \ln\left(\frac{738.16}{556.26}\right) - (0.0397 - 0.00499) = 0.0108 \text{ lb-moles}$$

$$E_{wt-toluene} = (0.0108 \text{ lb-moles})(92.13 \text{ lb/lb-mole}) = 0.995 \text{ lbs}$$

Step 5. Calculate the emission of air without the gas sweep present.

$$E_{n-nc} = n_{nc,1} - n_{nc,2} = 0.1685 - 0.1085 = 0.06 \text{ moles}$$

Step 6. Calculate the moles of gas sweep.

$$E_{n-gas\ sweep} = \left[\frac{760 \times (3 \text{ scfm} \times 60 \text{ min})}{998.9 \times 273.15} \right] = 0.501 \text{ moles air}$$

Step 7. Calculate the toluene emissions while taking the gas sweep into account with a 25% saturation level.

$$E_{n-toluene} = \left(\frac{0.06 + (0.25 \times 0.501)}{0.06} \right) \times 0.0108 = 3.08 \times 0.0108 = 0.0333 \text{ lb moles}$$

$$E_{wt-toluene} = (0.0333 \text{ lb-moles})(92.13 \text{ lb/lb-mole}) = 3.068 \text{ lbs}$$

$$E_{n-nc} = 0.06 + 0.501 = 0.561 \text{ lb-moles}$$

$$E_{wt-nc} = (0.561 \text{ lb-moles})(28.97 \text{ lb/lb-mole}) = 16.25 \text{ lbs}$$

3.7 Evaporation Models

3.7.1 Evaporation from an Open Top Vessel or a Spill

The rate of vaporization of a liquid can be modeled as a function of several characteristic factors of the compound being considered. [Crowl & Louvar, 2002]

$$E_{n-i} = \frac{M_i K_i A (P_i^{sat} - P_i)}{RT_L} \quad \text{Eq. 3-23}$$

Where E_n is the evaporation rate (mass/time).

M_i is the molecular weight of the volatile substance,

K_i is a mass transfer coefficient (length/time),

A is the evaporation surface area,

P_i^{sat} is the saturated solvent vapor pressure,

P_i is the actual vapor pressure near the liquid surface,

R is the ideal gas constant, and

T_L is the absolute temperature of the liquid.

For many cases, $P_{sat} \gg p$, and Eq. 3-23 may be simplified to

$$E_{n-i} = \frac{M_i K_i A P_i^{sat}}{RT_L} \quad \text{Eq. 3-24}$$

Eq. 3-24 may be used to estimate the vaporization rate of a volatile liquid from an open vessel or a liquid spill.

The ratio of the mass transfer coefficients between the compound of interest K and reference compound K_o is expressed as follows:

$$\frac{K_i}{K_o} = \left(\frac{D_i}{D_o} \right)^{2/3} \quad \text{Eq. 3-25}$$

The gas-phase diffusion coefficient D for a compound is estimated from the ratio of molecular weight of the compound of interest and a known compound (normally water) as follows:

$$\frac{D_i}{D_o} = \left(\frac{M_o}{M_i} \right)^{1/2} \quad \text{Eq. 3-26}$$

Combining Eq. 3-25 and Eq. 3-26 results in a relationship that can be used to estimate the mass transfer coefficient of a given volatile compound.

$$K_i = K_o \left(\frac{M_o}{M_i} \right)^{1/3} \quad \text{Eq. 3-27}$$

Water is commonly used as a base reference for estimating the mass transfer coefficient for many compounds of interest. The mass transfer coefficient of water at 77 F and 760 mm Hg. is 0.83 cm/s.

Illustration 3-19: Evaporation from a vessel with an open top.

A large open top vertical tank with a 6-ft diameter contains heptane. Estimate the evaporation rate from the tank at 25 C and 1 atm pressure.

The molecular weight of heptane is 100.2. The mass transfer coefficient is estimated using Eq. 3-24 with the known mass transfer coefficient for water of 0.83 cm/s.

$$K_i = K_o \left(\frac{M_o}{M_i} \right)^{1/3} = 0.83 \frac{\text{cm}}{\text{s}} \left(\frac{18.02}{100.2} \right)^{1/3} = 0.4685 \frac{\text{cm}}{\text{s}} \times \frac{3600 \cdot \text{s} \cdot \text{ft}}{30.48 \cdot \text{hr} \cdot \text{cm}} = 55.33 \frac{\text{ft}}{\text{hr}}$$

$$P_{\text{heptane}}^{\text{sat}} = 45.86 \text{ mmHg.}$$

$$A = \frac{\pi d^2}{4} = \frac{3.14 * 36 \text{ ft}^2}{4} = 28.26 \text{ ft}^2$$

$$E_{n-i} = \frac{M_i K_i A P_i^{\text{sat}}}{RT_L} = \frac{(100.2 \text{ lb/lb-mole})(55.33 \text{ ft/hr})(28.26 \text{ ft}^2)(45.86 \text{ mmHg})}{(998.9 \text{ ft}^3 \text{ atm/lb-mol}^\circ\text{K})(298.15^\circ\text{K})}$$

$$E_{\text{wt}-i} = 24.42 \text{ lb/hr}$$

Illustration 3-20: Evaporation losses from a spill.

Toluene is spilled onto the ground outside of a building. Determine the toluene evaporation rate based on the following data:

The ambient temperature (T) is 25°C or 298.15K. (°K = °C + 273.15)

The surface area (A) of the spill is 100 ft².

The molecular weight of toluene is 92.13 lb/lb-mole.

The vapor pressure of toluene is 28.445 mm Hg.

$$K_i = K_o \left(\frac{M_o}{M_i} \right)^{1/3} = 0.83 \frac{cm}{s} * \left(\frac{18.02}{92.13} \right)^{1/3} = 0.58 \frac{cm}{s} \times \frac{3600 \cdot s \cdot ft}{30.48 \cdot hr \cdot cm} = 68.50 \frac{ft}{hr}$$

$$E_{n-i} = \frac{M_i K_i A p^{sat}}{RT_L} = \frac{(92.13 \text{ lb/lb-mole})(68.50 \text{ ft/hr})(100.0 \text{ ft}^2)(28.44 \text{ mmHg})}{(998.9 \text{ ft}^3 \text{ mmHg/lb-mol}^\circ K)(298.15^\circ R)}$$

$$E_{n-i} = 60 \text{ lb/hr}$$

3.8 Emission Model for Liquid Material Storage

The preferred method for calculating emissions from storage tanks is the use of equations presented in AP-42. EPA has developed a software package (TANKS) for calculating these types of emissions. The reader is referred to Chapter 1 of this volume, *Introduction to Stationary Point Source Emissions Inventory Development*, for more information on using the TANKS program. Additionally, the reader should consult their state agency and/or the EPA's Clearinghouse for Inventories and Emission Factors (CHIEF) website for the most recent version of TANKS.

3.9 Emission Model for Wastewater Treatment

VOC emissions from a wastewater treatment system may be estimated using equations presented in Air Emissions Models for Waste and Wastewater (EPA, 1994a), and Chapter 5, Preferred and Alternative Methods for Estimating Air Emissions from Wastewater Collection and Treatment Facilities, of this volume. These documents, as well as models such as WATER9 are available on the EPA's CHIEF website.

3.10 Using Sampling and Test Data to Validate Emission Studies

Use of stack and/or industrial hygiene test data is likely to be the most accurate method of quantifying air emissions from chemical manufacturing operations. However, collection and analysis of air samples from manufacturing facilities can be very expensive and especially complicated for chemical manufacturing facilities where a variety of VOCs are emitted and where most of the emissions may be fugitive in nature. Test data from one specific process may not be representative of the entire manufacturing operation and may provide only one example (a snapshot) of the facility's emissions.

To be representative, test data would need to be collected over a period of time that covers production of multiple chemical formulations. It may be necessary to sample multiple production areas. In addition, these methods do not address fugitive emissions that occur outside of a building. If testing is performed, care should be taken to ensure that a representative operational cycle has been selected. If possible, full cycles should be monitored as opposed to portions of cycles.

For example, in some facilities the typical process vessel used in mixing or dispersion operations may have hinged lids or other covers that are loosely fitting. Additionally, these vessels may have top mounted agitators that can be raised or lowered depending upon mixing elevation requirements. A gas tight agitator seal may not be practical for this type of process vessel. In other cases, the mixing vessel may be completely open top. Quantifying the gas sweep rate and volatile vapor saturation level for the overall

emission process would not be possible in these cases. Developing a reliable emission model using classic modeling techniques presented in this document may not be reliable in this case.

US EPA Method 204D (Fugitive VOCs from Temporary Total Enclosure) may be used as a means of quantifying air emissions from specific equipment systems for one or more processes. Results from temporary total enclosure testing is considered to be more accurate than from using standardized emission models since the data is from accurate measurement sources. The results from validated emission measurement studies can be used in developing emission standards that in turn can be used to estimate emissions from partial or complete production operations.

Illustration 3-21: Using emission measurements to represent production operations.

A large mixing tank is used as part of a solvent blending operation. The vessel has a flat lid that contains several smaller hinged covers for hand holes and charge shoots. Additionally, the vessel has an agitator but no agitator seal. The tank vent is loosely connected to a large duct system that is powered by a remote exhaust fan near the roof. The exhaust manifold is monitored for air flow rate and solvent concentration using standardized instrumental analysis. During the time of testing the atmospheric pressure is measured to be 760 mm Hg (1.0 atm). The flow rate and temperature of the exhaust gas are measured to be 10 ft³/min (or 600 ft³/hr) and 25°C, respectively. Analytical measurements made during the process operation show the toluene and heptane content to be 2.8 mm Hg and 3.7 mm Hg in the exhaust gas, respectively. Calculate the average toluene and heptane emission rate during this process operation.

Using the partial pressure for each compound in conjunction with the ideal gas law and exhaust gas flow rate the following expression can be used to calculate the emission rate for a given pollutant.

$$Q_i = \frac{M_i p_i F}{RT}$$

where M_i = molecular weight of the pollutant,
 p_i = partial pressure of the pollutant in mm Hg,
 F = exhaust gas flow rate in ft³/hr,
 T = exhaust gas temperature in °K,
 R = universal gas constant for mm Hg, ft³, and °K.

$$\text{For Toluene: } Q_{\text{toluene}} = \frac{M_{\text{toluene}} p_{\text{toluene}} F}{RT} = \frac{92.13 * 2.8 * 600}{998.9 * 298.15} = 5.2 \frac{\text{lbs}}{\text{hr}}$$

$$\text{For Heptane: } Q_{\text{heptane}} = \frac{M_{\text{heptane}} p_{\text{heptane}} F}{RT} = \frac{100.21 * 3.7 * 600}{998.9 * 298.15} = 7.5 \frac{\text{lbs}}{\text{hr}}$$

Note that the actual concentration and temperature of the process mixture that is contained in the process vessel are not required in this calculation since the emissions from the process are being entirely characterized from the analysis of the exhaust gas from the system. Also, it is important that only the process being studied be in operation during the measurement study and that contaminants from other parts of the facility not be present.

3.10.1 Correlating Standard Emission Models to Test Results

Results from total enclosure testing can then be used to correlate with conventional batch modeling formulas. Process variables such as vessel gas sweep rate and/or saturation levels may be estimated based on the test data.

For example, Eq. 3-28 relates the evaporation rate for a volatile compound i within a vessel to its molecular weight, mass transfer coefficient, surface area, and other known variables. [Crowl & Louvar, 2002]

$$Q_m = \frac{MKA}{RT} (P_i^{Sat} - p_i) \quad \text{Eq. 3-28}$$

where Q_m = evaporation rate (lb/min)
 M = molecular weight of compound i
 K = mass transfer coefficient (ft/min)
 A = surface area (ft²)
 R = ideal gas constant
 T = temperature of liquid
 P_i^{Sat} = saturated vapor pressure of compound i
 p_i = actual vapor pressure of compound i next to the liquid surface.

Eq. 3-29 is the basic equation for calculating the emission rate for compound i from a gas sweep or purge operation based on the exit gas flow rate, partial pressure of compound i , molecular weight, and other known variables.

$$Q_v = \frac{FP_T}{RT} \frac{p_i}{P_T} M = \frac{MFp_i}{RT} \quad \text{Eq. 3-29}$$

where Q_v = emissions from vessel vent (lb/min)
 F = exit gas flow rate (ft³/min)
 P_T = overall system pressure
 R = ideal gas constant
 T = temperature of liquid
 p_i = actual vapor pressure of compound i .
 M = molecular weight of compound i .

For a vessel at steady state conditions, the emission rate from the gas sweep activity is equal to the evaporation rate or compound i from the liquid within the vessel. [Hatfield, 2003a] These two equations can be set equal and solved for the saturation level S_i as follows:

$$Q_m = Q_v$$

Substitute basic expressions

$$\frac{MKA}{RT} (P_i^{Sat} - p_i) = \frac{MFp_i}{RT}$$

Cancel out common terms

$$KA(P_i^{Sat} - p_i) = Fp_i$$

Expand expression

$$KAP_i^{Sat} - KAp_i = Fp_i$$

Rearrange terms
$$KAP_i^{Sat} = Fp_i + KAp_i = (F + KA)p_i$$

Divide by (F+KA)
$$p_i = \frac{KAP_i^{Sat}}{F + KA}$$

$$S_i = \frac{p_i}{P_i^{Sat}} = \frac{KA}{F + KA}$$

Rearrange to obtain saturation.

Eq. 3-30

Eq 3-30 is consistent with respect to units. If K (ft/min), A (ft²), and F (ft³/min) then S_i is dimensionless and represents the level of saturation as a decimal fraction between 0 and 1.0. When the purge rate becomes zero, the saturation level inside the tank becomes 1.0. The resulting emissions through the vent becomes zero because a purge does not exist through the vessel. When the purge rate increases to the point that F = KA then the saturation level becomes 0.5 (or 50%).

Eq 3-30 relates the saturation level of a volatile component the exit gas sweep rate (F) and the evaporation rate (KA). However, Eq 3.30 represents a worst case condition because it assumes that the gas space in the vessel is perfectly mixed. When F is equal to KA then the partial pressure of the volatile component is only 50% of the saturated vapor pressure. When F is greater than KA then the saturation level is greater than 50% and when F is smaller than KA then the saturation level is less than 50%.

Suppose a vessel with a diameter of 5 ft is partially filled with toluene at 25°C. The vapor pressure and molecular weight of toluene are 28.2 mm Hg and 92.13 lb/lb-mole, respectively. The cross sectional area of the tank or liquid surface area is calculated to be 19.6 ft². Assuming that the gas space in the vessel is mixed then the following calculations can be made.

$$K_i = K_o \left(\frac{M_o}{M_i} \right)^{1/3} = 0.83 \frac{cm}{s} \left(\frac{18.02}{92.13} \right)^{1/3} = 0.482 \frac{cm}{s} \times \frac{60 \cdot s \cdot ft}{30.48 \cdot min \cdot cm} = 0.949 \frac{ft}{min}$$

$$S_i = \frac{K_i A}{F + K_i A} = \frac{(0.949)(19.6)}{F + (0.949)(19.6)} = \frac{18.59}{F + 18.59}$$

Saturation S_i is plotted for this vessel as a function of F in Figure 3-1 and shows the relationship between exit gas sweep rate and saturation level of the exit vent gas with respect to toluene vapor pressure.

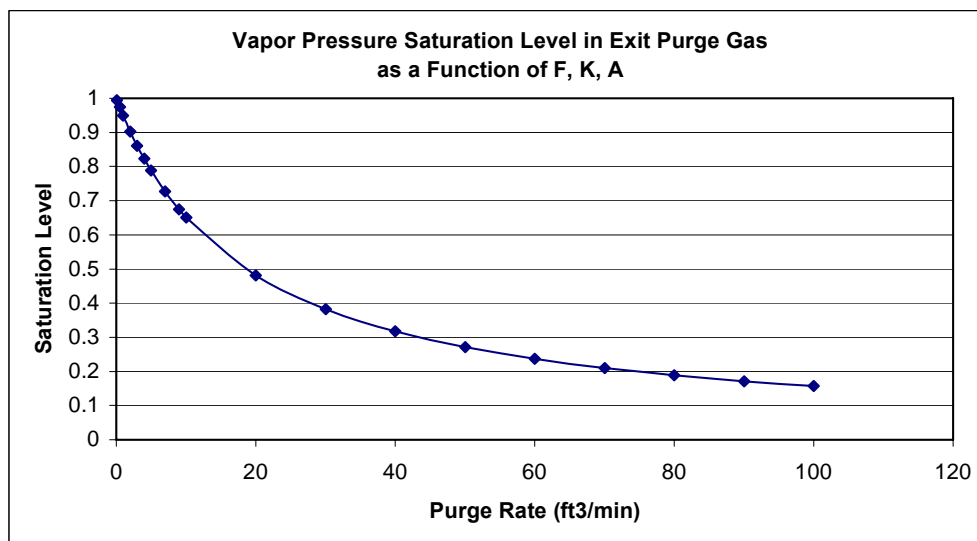

Figure 3-1. Saturation Level (S) Plotted as a Function of Exit Vent Gas Flow Rate.

Once the saturation factor S is known for any exit vent gas flow rate then the estimated emission rate for compound *i* can be plotted as a function of F as by substituting $p_i = S_i p_i^{Sat}$.

$$Q_v = \frac{MFp_i}{RT} = \frac{MFS_i p_i^{Sat}}{RT} \quad \text{Eq. 3-31}$$

The emission rate for this specific toluene example is plotted in Figure 3-2 in lb/hr as a function of exit gas sweep rate in SCFM.

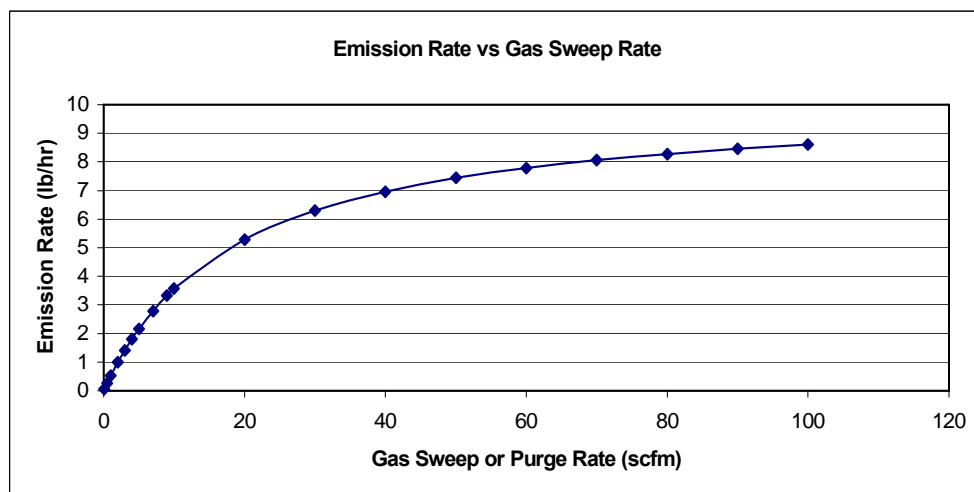

Figure 3-2. Toluene Emission Rate Plotted as a Function of Exit Gas Sweep Rate and Saturation Level.

The vessel had a loose fitting hinged cover and an over sized hole in the top where the agitator entered the vessel. The exit vent gas rate for the vessel could not be determined due to this equipment configuration. A Temporary Total Enclosure test was conducted on this vessel as it was holding toluene at 25°C while

mixing was underway. A steady state toluene emission rate was measured to be 5.14 lb/hr. From Figure 3-2, a 5.14 lb/hr toluene emission rate corresponds to an exit vent gas rate of 20 scfm. From Figure 3-1, a 20 scfm exit gas rate corresponds to a saturation level of 0.48 (or 48%).

If the process material is changed with respect to solvent composition then the established gas sweep and saturation level can be used in support of a re-evaluation of the revised operation. In this case the vapor pressure and other physical properties of the new process material would be incorporated into the basic purge model for emission estimates.

3.11 Emission Calculations Using Material Balance

If the equipment or process operation is such that standard modeling techniques can not be applied then a material balance approach may be used to estimate air emissions. Processes that fall into this category might include parts cleaning or degreasing systems where the equipment is open to the atmosphere and/or does not fit typical process vessel designs.

In such cases, the quantity of initial cleaning solvent would be weighed prior to being charged to the equipment system. Once the process operation has been completed then all remaining spent solvent would be collected and weighed. If non-volatile compounds such as oil or other materials are contained in the residual spent solvent then the material would need to be assayed for volatile solvent content.

If the test results are to be used for developing emission standards for a specific process operation then additional tests should be implemented to arrive at a statistically relevant emission estimation.

Illustration 3-22: Using material balance to estimate emissions from operations.

Fresh toluene solvent is charged to an equipment parts degreaser/cleaning unit. The initial amount of toluene charged is 350 lb. At the conclusion of the operation 347.5 lb. of spent toluene (contaminated with waste oil) is collected. A sample of the spent toluene is assayed using loss on drying (LOD) analysis to be 98.8% toluene by weight. Calculate the toluene evaporation losses from the operation.

Stream	Weight (lbs.)	Purity	Weight (lbs.)
Initial Toluene Charge	350.00	100.0%	350.00
Residual Toluene	347.50	98.8%	343.33
Toluene Emitted			6.67

3.12 Emission Calculations Using Emission Factors

Emission factors are commonly used to calculate emissions from chemical manufacturing facilities. EPA maintains a compilation of approved emission factors in *AP-42* for criteria pollutants and hazardous air pollutants (HAPs). Emission factors for equipment leaks may be found in *Protocol for Equipment Leak Emission Estimates* (EPA, 1995g). Chapter 4 of this volume discusses emission estimates from equipment leaks.

The most comprehensive source for toxic air pollutant emission factors is the Factor Information and Retrieval (FIRE) data system, which also contains criteria pollutant emission factors (EPA, 1995h).

4.0 Single Stage Vent Devices: Condensers, Vacuum Pumps, and Vacuum Steam Jets

There are many different equipment devices that can be installed and operated in the vent path depending upon what is needed by the process. A condenser would be specified if it was required to collect process vapors from the vent stream in the form of liquid condensate while a vacuum pump or steam jet would be used if vacuum was needed at the process vessel. In some cases the process vent path can contain one or more condensers followed by a vacuum pump followed by another condenser.

All of these devices including condensers, vacuum pumps, and vacuum steam jets have several things in common. As process vapors pass through the device the temperature and/or pressure changes. In most cases liquid condensate forms in the device and is discharged along with the remaining vapor. In the case of a vacuum steam jet or a liquid ring vacuum pump, working fluid (steam, water, or other fluid) enters the device and is allowed to mix with the process stream as it passes through the unit. A liquid phase is discharged with any remaining vapors similarly to the condenser. Simple diagrams of each type of device are presented in Figure 4-1.

For calculation purposes, one tends to consider that the liquid and vapor streams are in equilibrium with each other as they exit the device. Additionally, it is assumed that the material balance around the device is satisfied. The rate that material that enters the device is equal to the rate that material exits the device. These two assumptions are what enable one to solve the single stage device problem and to determine the exit stream flow rates and compositions.

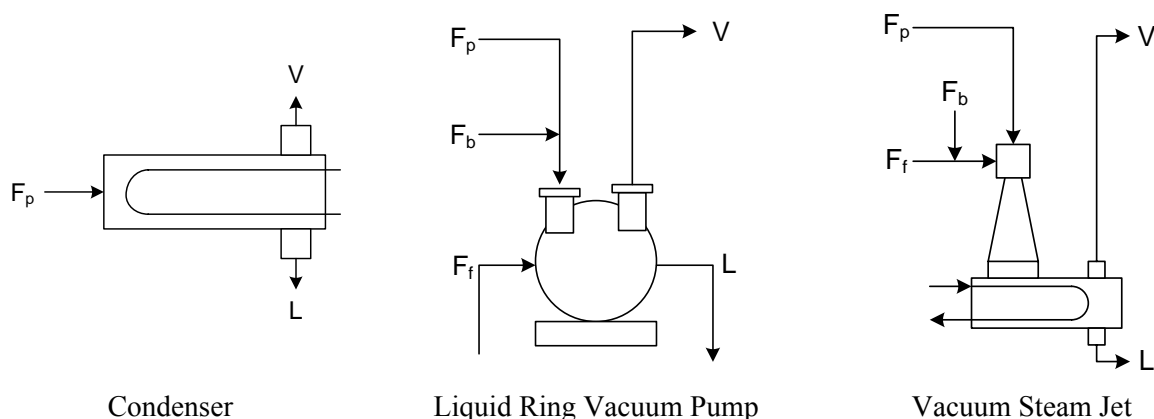

Figure 4-1. Diagrams of single stage vent devices.

4.1 General Calculation Considerations

4.1.1 Material Balance Considerations for the Vent Device

$$F = F_p + F_b + F_f \quad \text{Eq. 4-1}$$

Where F_p is the inlet process rate, F_b is any air or nitrogen bleed, and F_f is any working fluid such as steam, water, or other external fluid. V is the exit vapor stream and L is the exit liquid stream.

$$F = L + V \quad \text{Eq. 4-2}$$

$$z_i F = x_i L + y_i V \quad \text{Eq. 4-3}$$

Where F is the combined inlet molar flow rate, L is the molar flow rate of the exit liquid stream and V is the molar flow rate of the vapor stream. z , x , and y are the mole fractions of component i for the respective stream.

If air, nitrogen, or another noncondensable gas with a low solubility is present then one can assume that all of the non condensable gas exits the device by way of the exit gas stream V and that none is present in the exit liquid stream L .

$$z_{nc} F = y_{nc} V \quad \text{where } x_{nc} = 0 \quad \text{Eq. 4-4}$$

For most vent devices, Eq. 4-4 is a very important relationship because it provides a straightforward way to calculate the amount of the non condensable component contained in the exit vapor stream V . Additionally, Eq. 4-4 provides a way to calculate the moles of component i in the exit vapor stream V from the moles of the non condensable component nc and the partial pressure ratio of component i and the non condensable component.

$$n_i = n_{nc} \frac{P_i}{P_{nc}} \quad \text{Eq. 4-5}$$

4.1.2 Equilibrium Relationships Between the Exit Liquid and Vapor Streams

Equilibrium relationships that exist between the exit liquid stream L and the exit vapor stream V are needed in order to relate the relative amount of component i that exists between L and V . If equilibrium is achieved between L and V then Eq. 4-6 and Eq. 4-7 must be satisfied.

$$x_i \gamma_i P_i = p_i \quad \text{Eq. 4-6}$$

$$y_i = \frac{p_i}{P_{sys}} = \frac{x_i \gamma_i P_i}{P_{sys}} \quad \text{Eq. 4-7}$$

Where x and y are mole fractions of component i in streams L and V . P_i and p_i are the pure vapor pressure and partial pressure of component i . P_{sys} is the system pressure and γ_i is the activity coefficient of component i .

4.1.3 Checking to See If Condensation Takes Place in the Vent Device

If the process stream contains a noncondensable component (air, nitrogen, or other gases) then it's important to check to see if condensation will likely occur before proceeding to solve the condenser problem. This is not normally an issue with calculations involving liquid ring vacuum pumps and vacuum steam jets because of the significant presence of the working fluid (water, steam, or another fluid). However, if the process stream from the process contains a large amount of noncondensable component then it is possible that condensation may not take place in a standard condenser if the dew point temperature of the process stream is lower than the condenser operating temperature.

It is relatively easy to test for condensation by first assuming that condensate does form containing all of the condensable components from the process stream. Then calculating the mole fraction that each component would need to have at the condenser temperature in order for the partial pressure to be the

same as the partial pressure at the inlet conditions. The sum of the resulting liquid mole fractions is calculated. If the sum of the x_i 's is equal to or greater than 1.0 then one can assume that condensation takes place in the condenser. However, if the sum of the x_i 's is less than 1.0 then one can assume that condensation does not take place and that all of the process exits the condenser as a vapor stream.

$$x_i \gamma_i P_i = p_i \quad \text{Eq. 4-6}$$

$$x_i = \frac{P_i}{\gamma_i P_i} \quad \text{Eq. 4-8}$$

Where P_i is the pure vapor pressure at condenser temperature,

p_i is the partial pressure at the condenser inlet.

$$\sum x_i \geq 1.0$$

Condensation takes place at $T_{\text{condenser}}$.

$$\sum x_i < 1.0$$

Condensation does not take place at $T_{\text{condenser}}$

4.1.4 General Calculation Approach for Solving Single Stage Vent Device Problems

If the inlet process stream to the single stage device contains only one condensable component and one noncondensable component then the composition of the exit vent stream V is fairly straight forward calculation. The concentration of condensable component in the liquid stream L is 100%, therefore, p_i is equal to P_i for the device temperature. Eq. 4-5 can then be used to directly calculate the moles of the condensable component in the exit vapor stream V.

However, if the process contains two or more condensable components then the calculation becomes much more involved because there are not enough independent equations to solve the problem algebraically. Instead, equations are constructed to express the component material balance while other equations are written for the equilibrium relationships that exist between exit streams L and V. The general solution to the problem is found by iterating back and forth between the material balance equations and the equilibrium equations. The estimated quantity of each component that is contained in the liquid and vapor streams is improved with each iteration. Iterations continue until all equations are satisfied within an acceptable tolerance. When an iterative approach is needed then the Newton-Raphson or a material balance correction approach can be applied as a means to achieving convergence. Both convergence procedures will be presented in the illustrations that are presented.

4.1.5 Partial Condensers

Partial condensers are frequently used to separate compounds from a process that have a much lower boiling point than remaining compounds in the process. For example, suppose a process that is carried out in a toluene solvent ($T_b = 110^\circ\text{C}$) chemically produces methyl chloride ($T_b = -30^\circ\text{C}$) along with several other compounds having normal boiling points that are greater than 50°C . Now suppose that it is desired to remove methyl chloride from the batch. If the process stream is in the vapor state then a partial condenser could be used at a temperature that is above the boiling point of the methyl chloride and below the boiling point of the toluene and other compounds in the process so that the methyl chloride would remain as a gas and the remaining compounds would tend to condense. A majority of the methyl chloride would exit the partial condenser as a vapor and the rest of the process stream would exit as a liquid condensate. Only minor amounts of methyl chloride would be left with the batch and only a small

quantity of toluene and other batch compounds would be left in the vapor discharge with the methyl chloride.

The general approach to solving the partial condenser problem is to use the Rachford-Rice equation which combines the material balance constraints with the equilibrium constraints. The Newton-Raphson procedure is used until convergence is achieved. This procedure will be explained further in a worked illustration later in this section.

4.1.6 Total Condensers

Generally, when one refers to condensers used in industry he or she might be thinking about condensers where everything in the process condenses to a liquid. For example, in a batch distillation a solvent is placed in a still vessel and heated to its boiling point. Solvent vapors leave the still and enter an overhead condenser where all of the solvent condenses back into a liquid. Condensate formed in the condenser is then collected in a receiving vessel. Heat continues to be applied to the still until all of the solvent has been distilled. In this example, 100% of the solvent vapor that entered the condenser was condensed and collected in the receiving vessel and none of the solvent left as a vapor. A condenser operated in this manner would be referred to as a total condenser since the entire inlet process vapor was converted into a liquid condensate. Emissions would not occur from the condenser directly since the process vapor does not contain a non condensable gas component. However, emissions would occur from the distillate receiver where the condensate is being collected and non condensable gases which are saturated with solvent vapors are exiting the receiver vent.

4.1.7 Vent Condensers

Many process operations (heating, charging, purging, etc) generate solvent emissions even though the batch is well below the boiling point. This is the result of non condensable gases (air, nitrogen, etc) that are leaving the process vessel which carry solvent vapors in the process. When vapors from these operations flow through a condenser that is colder than the vapor stream then the dew point is reached and condensation takes place. Non condensable gases exit the condenser with a reduced level of solvent vapors due to effect that the colder temperature has had on the vapor pressure of the condensable components.

Vent condensers represent a large percentage of how most condensers are operated in the field. When a total condenser is not being used to condense solvent vapors from a distillation operation then they typically operate like a vent condenser at other times during the process. Three procedures are presented for solving the vent condenser problem including the Modified Rachford-Rich equations, the vapor pressure correction method, and the material balance correction method.

4.1.8 Liquid Ring Vacuum Pumps

Liquid ring vacuum pumps are used to supply vacuum for certain process activities such as vacuum distillations, solids drying, and other operations. Liquid enters the pump and operates in conjunction with the rotating asymmetric internals to produce a low pressure side and a high pressure side by way of several vanes and chambers. In most cases, a large percentage of the liquid that passes through the pump is recycled to the inlet while the remainder is discharged to waste treatment or for subsequent processing. Fresh liquid makeup is added as required by the vacuum pump. In many cases, the operating liquid for the vacuum pump is water although other process fluids including vacuum pump oil are also used.

Liquid ring vacuum pump problems can be solved using the same approach that is used to solve vent condenser problems. All inlet streams to the liquid ring pump (process vapor stream, external air bleed, and working fluid throughput) are combined as a single process stream. The final discharge temperature and pressure are used for the equilibrium calculations. A worked illustration is presented which applies the vapor pressure correction method to solve the emission calculation.

4.1.9 Vacuum Steam Jets

Vacuum steam jets are also used to supply vacuum to certain process activities such as vacuum distillations, solids drying, and other operations. Steam jets will normally enable lower pressures to be achieved than liquid ring pumps (assuming that water is being used as the working fluid). High pressure steam enters the jet through a special nozzle where it is released and allowed to flow through a chamber with an increasing cross sectional area. As the chamber cross sectional area increases, the steam must undergo a reduction in velocity which causes vacuum to be created at the process inlet. Process vapors enter the steam jet through the inlet vacuum port and mix with the working steam. The combined steam and the process vapor stream leave the vacuum chamber and pass through an internal condenser where the steam and other vapors are condensed and the remaining vapor discharged to the atmosphere.

Vacuum steam jets problems can be solved using the same approach that is used to solve vent condenser problems. All inlet streams to the vacuum steam jet (process vapor stream, external air bleed, and steam) are combined as a single process stream. The final discharge temperature and pressure are used for the equilibrium calculations. A worked illustration is presented which applies the material balance correction method to solve the emission calculation.

4.2 Illustrations

Several worked illustrations are presented as a general guide for performing condenser calculations in a variety of configurations. As mentioned earlier, a major difference between the calculation of partial condensers and vent condensers is in how the material balance is applied to the inlet and outlet streams. For the partial condenser, the material balance is applied to inlet and outlet streams as shown in Eq. 4-2. For the vent condenser, the material balance is normally applied directly to the noncondensable gas as shown in Eq. 4-4. The composition of the exit vapor stream and the exit liquid stream is then established through vapor pressure calculations. If the process involves only a single condensable component then the calculation of the exit vapor stream is straight forward. However, if two or more condensable components are contained in the process then the calculation of the exit vapor stream normally requires iterations between the vapor pressure equilibrium calculations and the material balance calculations until both relationships are satisfied.

4.2.1 Condensers with One Condensable Component

Three examples are presented for condensers with inlet gas streams that consist of a noncondensable and one condensable component. In illustration 4-1 the entire system is at atmospheric conditions. In illustration 4-2 the process vessel and condenser are under vacuum. In illustration 4-3, the process vessel is under vacuum, but the condenser is located on the outlet side of the vacuum pump. Each of these examples uses Eq. 4-5 to calculate the amount of the condensable component leaving in the condenser outlet vapor stream. The fraction of the inlet condensable that leaves in the condenser exit vapor is also calculated in each example, although note that two approaches are used.

Illustration 4-1: Condenser with solvent vapor heptane and nitrogen

Nitrogen gas at 25°C and partially saturated with heptane vapor at a 69% level is vented from a process vessel (see Illustration 3-7 in section 3.2.2 of this document) into a condenser. The nitrogen gas constituent has a flow rate of 600.0 SCFH. The gas stream flows through a condenser and is discharged at 5°C and 760 mm Hg.

Calculate the heptane emissions from the condenser over a one hour period. Calculate the material balance for the condenser and the percent removal of heptane.

Step 1. The condenser has the following operating conditions.

Heptane	molecular weight	100.205
Nitrogen	molecular weight	28.013
P_{heptane}	45.69 mmHg @ 25°C	
P_{heptane}	15.43 mmHg @ 5°C	
T_{inlet}	25°C, 298.15°K	Condenser gas inlet
T_{exit}	5°C, 278.15°K	Condenser gas exit
P_{sys}	760 mm Hg	System pressure
Time	1 hr	Time for event

Universal Gas Constant:
$$R = 998.9 \frac{\text{mmHg} \cdot \text{ft}^3}{\text{lb} - \text{mole} \cdot ^\circ\text{K}}$$

Step 2. Calculate the amount of nitrogen that passes through the condenser.

We can assume that 100% of the nitrogen gas exits the condenser in the gas phase since little if any would condense with the heptane at 5°C. The amount of nitrogen flowing through the system over a 1.0 hour period is 600.0 ft³ (at 273.15°C & 760 mm Hg).

$$n_{N_2} = \frac{P_{N_2} V}{RT} = \frac{760 \text{ mmHg} \cdot 600 \text{ ft}^3}{(998.9)(273.15 \text{ K})} = 1.671 \text{ lb} - \text{moles}$$

$$E_{N_2} = 1.671 * 28.013 \text{ MWt} = 46.817 \text{ lb}$$

Step 3. Calculate the amount of heptane that enters the condenser in one hour.

The vent stream enters the condenser at 25°C with a heptane saturation level of 69%. In order to calculate the heptane content in the inlet gas stream we must first know the pure component vapor pressure for heptane at the 25°C stream temperature. Then the partial pressure of the heptane can be calculated for the 69% saturation level. The moles of heptane in the inlet gas stream can be calculated from the ratio of the partial pressure of heptane to the partial pressure of nitrogen and the molar rate of nitrogen.

$$0.69 \times 45.69 \text{ mmHg} = 31.53 \text{ mmHg}$$

The heptane is 69% saturated and so the vapor pressure of heptane is 31.53 mm Hg. The partial pressure of nitrogen is determined by the difference between the total system pressure, 760 mm Hg, and the partial pressure of heptane.

$$p_{N_2} = P_{sys} - p_H = 760 \text{ mmHg} - 31.53 \text{ mmHg} = 728.47 \text{ mmHg}$$

The moles of heptane entering the condenser over a one hour period may now be calculated from the moles of nitrogen in the inlet stream and the ratio of the partial pressure of heptane and the partial pressure of nitrogen.

$$\frac{n_H}{n_{N_2}} = \frac{p_H}{p_{N_2}} \text{ therefore } n_H = \frac{p_H}{p_{N_2}} n_{N_2}$$

$$n_H = \frac{31.53 \text{ mmHg}}{728.47 \text{ mmHg}} 1.671 \text{ lb moles} = 0.07233 \text{ lb moles}$$

$$F_{H,in} = 0.07233 \text{ lb moles} \times 100.205 \text{ MWt} = 7.247 \text{ lb}$$

Step 4. Calculate the partial pressure of the heptane at condenser exit temperature.

The exit gas condenser temperature is given to be 5°C. The vapor pressure of heptane in the liquid state can be calculated using the Antoine equation at 5°C (or 278.15°K). The heptane vapor pressure at 5°C is 15.43 mm Hg and less than the 31.53 mm Hg vapor pressure at the condenser inlet. Therefore, condensation must have taken place. The partial pressure of the nitrogen component at the condenser exit can be calculated by subtracting the heptane vapor pressure from the total system pressure.

$$p_{N_2,5^\circ C} = P_{sys} - p_H = 760 \text{ mmHg} - 15.43 \text{ mmHg} = 744.57 \text{ mmHg}$$

Step 5. Calculate the heptane emissions from the condenser over the one hour period.

The final heptane emission level $E_{H,exit}$ may be calculated by multiplying the moles of nitrogen leaving the condenser by the ratio of the heptane and nitrogen partial pressures at the condenser exit conditions. Once $E_{H,exit}$ is known then $L_{H,exit}$ may be calculated by subtracting $E_{H,exit}$ from $F_{H,inlet}$.

$$\frac{n_H}{n_{N_2}} = \frac{p_H}{p_{N_2}} \text{ therefore } n_H = \frac{p_H}{p_{N_2}} n_{N_2}$$

$$n_{H,5^\circ C} = \frac{15.43 \text{ mmHg}}{744.57 \text{ mmHg}} 1.671 \text{ lb moles} = 0.03463 \text{ lb moles}$$

$$E_{H,exit} = (0.03463 \text{ lb moles})(100.205 \text{ MWt}) = 3.47 \text{ lb}$$

$$L_{H,exit} = 7.25 \text{ lb} - 3.47 \text{ lb} = 3.78 \text{ lb}$$

$$E\%_{heptane} = 100\% * \frac{3.47 \text{ lb}}{7.25 \text{ lb}} = 47.86\%$$

$$\text{Condensed \%}_{\text{heptane}} = 100\% - 47.86\% = 52.14\%$$

Summary Results

	Condenser Inlet	Condenser Condensate	Condenser Exit Vapor
heptane	7.25 lb	3.78 lb, 52.14%	3.47 lb, 47.86%
nitrogen	46.82 lb	0.0 lb, 0.0%	46.82 lb, 100.0%

Illustration 4-2: Condenser with toluene solvent vapor and nitrogen at vacuum conditions

A vacuum receiver in a distillation operation is vented through a condenser to a vacuum pump operating at 175 mm Hg. The process vapor entering the condenser consists of nitrogen (85 mm Hg) and toluene (90 mm Hg).

1. At what temperature must the condenser operate before condensation will take place?
2. If the condenser operates at 10°C, what percent of the toluene vapor to the condenser would exit as vapor?
3. If the nitrogen component of the vapor stream is 10 lb/hr, what would the toluene emission rate be from the condenser?

Universal Gas Constant: $R = 998.9 \frac{\text{mmHg} \cdot \text{ft}^3}{\text{lb} - \text{mole} \cdot ^\circ\text{K}}$

Gas Law: $n = \frac{PV}{RT}$ also $n_i = \frac{P_i V}{RT}$ for component i in the gas space.

Step 1. In order for condensation to take place, the pure vapor pressure of toluene would need to be below 90 mm Hg.

The Antoine equation may be solved for the temperature that would result in a 90 mm Hg vapor pressure for toluene.

Antoine Equation: $P_i = \exp\left(a - \frac{b}{T + c}\right)$

$$\ln(P_i) = a - \frac{b}{T + c}$$

$$T = \frac{b}{a - \ln(P_i)} - c = \frac{3096.52}{16.0127 - \ln(90.0)} - (-48.78)$$

$$T = 322.61^\circ\text{K} = 49.46^\circ\text{C}$$

Step 2. If the condenser operates at 10°C, what percent of the toluene inlet condenser process stream would exit as vapor?

The molar ratio between the toluene and nitrogen in the inlet stream can be calculated from the respective partial pressures. The same calculation can be made at the condenser exit. The percent toluene emitted

from the condenser may then be calculated by dividing the molar ratio of toluene to nitrogen at the exit by the molar ratio at the inlet.

$$\frac{p_T}{p_{N_2}} = \frac{90.0 \text{ mmHg}}{(175.0 - 90.0) \text{ mmHg}} = 1.059 \frac{\text{mole toluene}}{\text{mole nitrogen}}$$

$$\frac{p_T}{p_{N_2}} = \frac{12.43 \text{ mmHg}}{(175.0 - 12.43) \text{ mmHg}} = 0.076 \frac{\text{mole toluene}}{\text{mole nitrogen}}$$

$$E_T \% = \frac{0.076}{1.059} * 100\% = 7.18\%$$

Step 3. If the nitrogen component of the vapor stream is 10 lb/hr, what would the toluene emission rate be from the condenser?

We can assume that 100% of the nitrogen exits the condenser in the gas phase since little if any would condense with the toluene. The rate that nitrogen flows through the system over 10.0 lb/hr.

$$n_{N_2} = \frac{10.0 \text{ lb/hr}}{28.013 \text{ MWt}} = 0.357 \text{ lb - moles/hr}$$

$$n_T = n_{N_2} * \frac{p_T}{p_{N_2}} = 0.357 * \frac{12.43 \text{ mmHg}}{(175 - 12.43) \text{ mmHg}} = 0.027 \text{ lb - moles/hr}$$

$$E_T = 0.027 \frac{\text{lb - moles}}{\text{hr}} * 92.13 \frac{\text{lb}}{\text{lb - moles}} = 2.49 \frac{\text{lb}}{\text{hr}}$$

Illustration 4-3: Condenser with toluene vapor and nitrogen at atmospheric pressure

If the condenser described in Illustration 4-2 were located at the atmospheric discharge of the vacuum pump instead of on the vacuum inlet side what would the condenser performance been? The vacuum pump is a dry pump and the discharge vapor temperature is sufficiently warm due to adiabatic compression that none of the toluene condenses at the 760.0 mm Hg discharge pressure. The partial pressure for the toluene component is 391 mm Hg and the nitrogen flow rate is 10 lb/hr.

1. At what temperature must the condenser operate before condensation will take place?
2. If the condenser operates at 10°C, what percent of the toluene vapor to the condenser would exit as vapor?
3. If the nitrogen component of the vapor stream is 10 lb/hr, what would the toluene emission rate be from the condenser?

Universal Gas Constant: $R = 998.9 \frac{\text{mmHg} \cdot \text{ft}^3}{\text{lb - mole} \cdot ^\circ\text{K}}$

Gas Law: $n = \frac{PV}{RT}$ also $n_i = \frac{P_i V}{RT}$ for component i in the gas space.

Step 1. In order for condensation to take place, the pure vapor pressure of toluene would need to be below 391 mm Hg.

The Antoine equation may be solved for the temperature that would result in a 391 mm Hg vapor pressure for toluene.

Antoine Equation:
$$P_i = \exp\left(a - \frac{b}{T + c}\right)$$

$$\ln(P_i) = a - \frac{b}{T + c}$$

$$T = \frac{b}{a - \ln(p_i)} - c = \frac{3096.52}{16.0127 - \ln(391)} - (-48.78)$$

$$T = 361.9^\circ\text{K} = 88.8^\circ\text{C}$$

Step 2. If the condenser operates at 10°C, what percent of the toluene vapor to the condenser would exit as vapor?

The molar ratio between the toluene and nitrogen in the inlet stream can be calculated from the respective partial pressures. The same calculation can be made at the condenser exit. The percent toluene emitted from the condenser may then be calculated by dividing the molar ratio of toluene to nitrogen at the exit by the molar ratio at the inlet.

$$\frac{p_T}{p_{N_2}} = \frac{391.0 \text{ mmHg}}{(760.0 - 391.0) \text{ mmHg}} = 1.060 \frac{\text{mole toluene}}{\text{mole nitrogen}}$$

$$\frac{p_T}{p_{N_2}} = \frac{12.43 \text{ mmHg}}{(760.0 - 12.43) \text{ mmHg}} = 0.017 \frac{\text{mole toluene}}{\text{mole nitrogen}}$$

$$E_T \% = \frac{0.017}{1.060} * 100\% = 1.60\%$$

Step 3. If the nitrogen component of the vapor stream is 10 lb/hr, what would the toluene emission rate be from the condenser?

We can assume that 100% of the nitrogen exits the condenser in the gas phase since little if any would condense with the toluene. The rate that nitrogen flows through the system is 10.0 lb/hr.

$$n_{N_2} = \frac{10.0 \text{ lb/hr}}{28.013 \text{ MW}_t} = 0.357 \text{ lb - moles/hr}$$

$$n_T = n_{N_2} * \frac{p_T}{p_{N_2}} = 0.357 * \frac{12.43 \text{ mmHg}}{(760 - 12.43) \text{ mmHg}} = 0.00594 \text{ lb - moles/hr}$$

$$E_T = 0.00594 \frac{\text{lb - moles}}{\text{hr}} * 92.13 \frac{\text{lb}}{\text{lb - moles}} = 0.55 \frac{\text{lb}}{\text{hr}}$$

4.2.2 Partial Condensers

The traditional approach to solving the partial condenser problem is known as the Rachford-Rice Equation [Wankat], shown in equation Eq. 4-9. Many references exist for this procedure and the reader is encouraged to review the literature for additional insights and understanding. [Rachford & Rice][Henley & Seader]

$$f(V/F) = \sum_{i=1}^c \frac{(K_i - 1)z_i}{1 + (K_i - 1)V/F} = 0 \quad \text{Eq. 4-9}$$

Where

$$K_i \equiv \frac{y_i}{x_i} = \frac{\gamma_i P_i}{P_{\text{sys}}}$$

If the system is ideal then the activity coefficient γ_i can be set equal to 1.0 and the value for K_i becomes a constant for all compositions at the fixed system temperature and pressure.

$$K_i = \frac{P_i}{P_{\text{sys}}}, \text{ where } \gamma_i = 1.0 \quad \text{Eq. 4-10}$$

Assuming that the partial condenser is being operated at a temperature that is between the dew point and the liquid boiling point of the inlet process stream then V/F must have a value that is between 0.0 and 1.0. For example, if $V/F = 0.4$ then this would mean that 40% of the exit process stream will be vapor and 60% will be liquid. By solving the Rachford-Rice function we are simply looking for the value of V/F ($0.0 < V/F < 1.0$) that enables $f(V/F)$ to become zero. When V/F is too low then $f(V/F)$ will be less than zero and when V/F is too high then $f(V/F)$ will be greater than zero. Figure 4-2 presents a typical example of a plot of $f(V/F)$ versus V/F . In this case, the solution to Eq. 4-9 would occur when V/F is approximately 0.43.

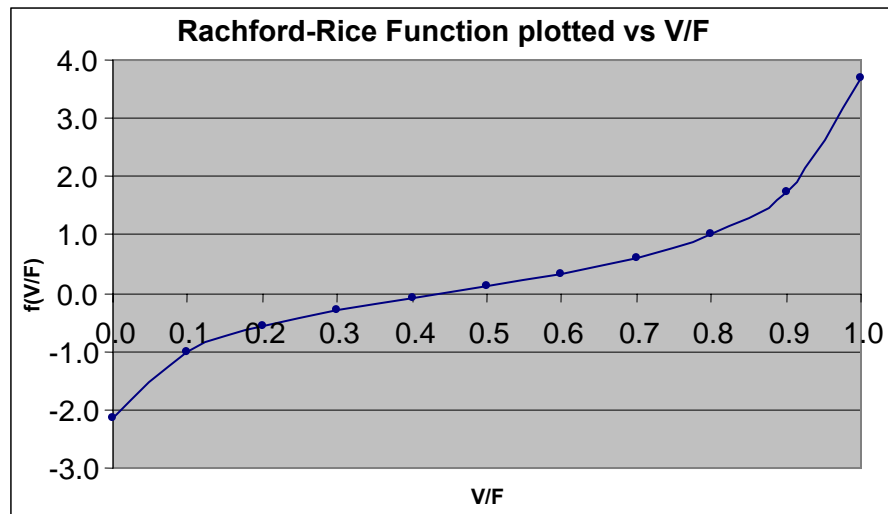

Figure 4-2. Generalized Rachford-Rice equation.

Solving the Rachford-Rice condenser model requires that a numerical search routine be applied since there are not enough independent equations to solve for V/F algebraically. Numerical search routines such as False Position and Newton's method can be applied until V/F converges to the desired degree of accuracy or tolerance. If the slope of $f(V/F)$ is sufficiently large near the solution then the False Position and Newton's method will tend to converge rapidly [Henley & Seader][Rachford & Rice]. Standard spreadsheet software programs generally offer built in goal seeking routines that can be used to solve the Rachford-Rice condenser model.

Once V/F has been determined where $f(V/F) = 0$ then the composition of the exit liquid L and vapor V streams can be directly calculated using Eq. 4-11 through Eq. 4-14.

$$V = F (V/F) \quad \text{Eq. 4-11}$$

$$L = F - V \quad \text{Eq. 4-12}$$

$$x_i = \frac{z_i}{1 + (V/F)(K_i - 1)} \quad \text{Eq. 4-13}$$

$$y_i = x_i K_i \quad \text{Eq. 4-14}$$

Newton's Method

Using Newton's method, a predicted value of V/F for iteration $k+1$ is computed from the recursive relation shown in Eq. 4-15 where $f(V/F)$ is expressed in Eq. 4-9 and $f'(V/F)$ is expressed in Eq. 4-16.

$$(V/F)_{k+1} = (V/F)_k - \frac{f(V/F)_k}{f'(V/F)_k} \quad \text{Eq. 4-15}$$

$$f'(V/F)_k = \sum_{i=1}^c \frac{(K_i - 1)^2 z_i}{[1 + (K_i - 1)(V/F)_k]^2} \quad \text{Eq. 4-16}$$

Eq. 4-15 should be iterated until the desired accuracy of V/F is achieved. Stop iterating when two successive values of V/F satisfy the conditions in Eq. 4-17.

$$\frac{|(V/F)_{k+1} - (V/F)_k|}{(V/F)_k} < \textit{tolerance level} \quad \text{Eq. 4-17}$$

The acceptable tolerance level may vary depending on the application, but generally it should be small. For example, 0.0001 might be a reasonable value.

Illustration 4-4: Rachford-Rice Method

A partial condenser is used to separate excess methyl chloride from a process stream for incineration. The process vapor stream enters the condenser containing methyl chloride (1,250 lb/hr), n-hexane (2,585 lb/hr), and toluene (4,125 lb/hr). The partial condenser operates at atmospheric pressure (760 mm Hg) and at 45°C. The process stream may be calculated as an ideal mixture so that Raoult's Law may be applied.

Calculate the flow rate and composition of the discharge vapor and condensate liquid streams from the partial condenser assuming that the exit vapor and liquid stream are at equilibrium.

Step 1. Establish characteristics of the inlet feed stream.

Feed composition F_i (lb-moles/hr) and mole fraction z_i are calculated for each component in the inlet stream from the mass flow rates and molecular weights that are given. The pure vapor pressure (Pure VP) for each component in the feed stream at 45°C has been calculated based on the Antoine Equation and is supplied for this problem. K_i has been calculated using Eq. 4-10 because the problem stated that the process mixture could be treated as ideal. The results are presented in Table 4-1.

Table 4-1. Inlet Feed Stream Analysis

Compound	F_i lb/hr	MWt	F_i lb-moles/hr	z_i mole frac.	Pure VP _i (mm Hg) 45°C	$K_i=P_i/P_{sys}$
methyl chloride	1250.0	50.49	24.757	0.249	7369	9.696
n-hexane	2585.0	86.17	29.999	0.301	338	0.445
toluene	4125.0	92.13	44.774	0.450	74	0.097
Totals			99.6	1.00		

Step 2. Add known values to the Rachford-Rice equation.

The Rachford-Rice equation (Eq. 4-9) is populated using K_i and z_i from Table 4-1. Note that a separate term is required for each compound in the inlet gas stream.

$$f(V/F) = \sum_{i=1}^C \frac{(K_i - 1)z_i}{1 + (K_i - 1)V/F} = 0$$

$$0 = \frac{(K_{mc} - 1)z_{mc}}{1 + (K_{mc} - 1)V/F} + \frac{(K_h - 1)z_h}{1 + (K_h - 1)V/F} + \frac{(K_t - 1)z_t}{1 + (K_t - 1)V/F}$$

$$0 = \frac{(9.696 - 1)0.249}{1 + (9.696 - 1)V/F} + \frac{(0.445 - 1)0.301}{1 + (0.445 - 1)V/F} + \frac{(0.097 - 1)0.45}{1 + (0.097 - 1)V/F} \quad \text{Eq. 4-18}$$

Step 3. Add known values to the derivative of the Rachford-Rice equation.

The derivative of the Rachford-Rice equation (Eq. 4-16) is populated using the same data from Table 4-1.

$$f'(V/F)_k = \sum_{i=1}^C \frac{(K_i - 1)^2 z_i}{[1 + (K_i - 1)(V/F)_k]^2}$$

$$f'(V/F)_k = \frac{(9.696 - 1)^2 0.249}{(1 + (9.696 - 1)V/F)^2} + \frac{(0.445 - 1)^2 0.301}{(1 + (0.445 - 1)V/F)^2} + \frac{(0.097 - 1)^2 0.45}{(1 + (0.097 - 1)V/F)^2} \quad \text{Eq. 4-19}$$

Step 4. Solve for V/F using Newton's method.

Once Eq. 4-18 and Eq. 4-19 have been configured then guess an initial value for V/F and use Newton's method as shown in Eq. 4-15 until the accuracy as per Eq. 4-17 is less than 0.0001. The results of this iterative process are shown in Table 4-2. The initial guess for V/F was assumed to be 0.5. Inserting this value in Eq. 4-18 and Eq. 4-19 resulted in initial estimates for $f(V/F)$ and $f'(V/F)$ of 0.567262 and 2.053191, respectively. The next estimate of V/F was calculated using these values in Eq. 4-15, and then the initial and second estimates were compared using Eq. 4-17. This process was repeated for four iterations. At that point the value of V/F had converged within the specified tolerance level.

Table 4-2. Iteration Results for Illustration 4-4

Iteration	$(V/F)_k$	$f(V/F)$	$f'(V/F)$	$(V/F)_{k+1}$	$\left \frac{(V/F)_{k+1} - (V/F)_k}{(V/F)_k} \right $
1	0.5	0.567261	2.053191	0.223717	0.552565
2	0.223717	-3.45E-02	2.86477	0.235756	5.38E-02
3	0.235756	-7.89E-04	2.736357	0.236044	1.22E-03
4	0.236044	-4.16E-07	2.733474	0.236045	6.45E-07

The Rachford-Rice equation for this problem has been plotted in Figure 4-3. The solution to the problem where $f(V/F)$ crosses the axis at $V/F = 0.236$ and $f(V/F) = 0$ has been marked with the vertical line.

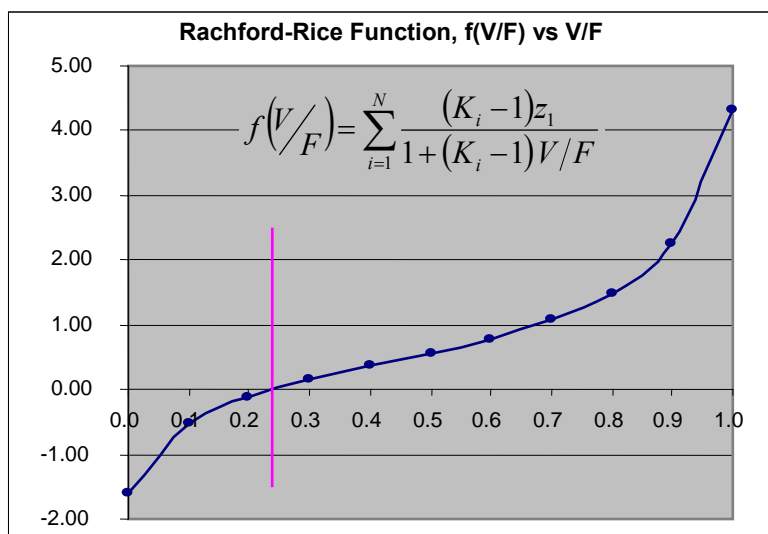
**Figure 4-3. Rachford-Rice Plot showing solution at $V/F = 0.236044$.****Step 5. Determine the outlet vapor and liquid stream flows and compositions.**

After V/F has been determined by trial and error, as shown in Table 4-2, then the molar flow rates of the exit liquid and vapor streams are calculated using Eq. 4-11 and Eq. 4-12. For example, the total moles of vapor is calculated as $F \times V/F$ ($99.6 \times 0.236045 = 23.494$ lbmoles/hr). The mole fractions of components in each exit stream are calculated using Eq. 4-13 and Eq. 4-14. Finally, the molar flow rates of each component are calculated by multiplying the total moles by the applicable mole fractions. The results of these calculations are shown in Table 4-3.

Table 4-3. Product Outlet Stream Analysis

Compound	x_i	Li (lb-moles/hr)	y_i	V _i (lb-moles/hr)
methyl chloride	0.081	6.196	0.79008	18.562
n-hexane	0.347	26.375	0.15427	3.624
toluene	0.572	43.466	0.05566	1.308
Totals	1.000	76.037	1.000	23.494

4.2.3 Vent Condensers with Single-Phase Condensate

When the process stream contains two or more condensable components and also a noncondensable gas component (air, nitrogen, etc.) then the Rachford-Rice equation that was discussed in section 4.2.2 must be modified in order to solve the condenser problem. As in illustration 4-4, the value of V/F that solves the equation must be determined iteratively. Alternatively, two other iterative approaches may be used. Both of these alternatives involve making an initial guess of the condensate composition. This information is used to solve material balances or equilibrium relationships. If the relationships are not met within a specified level of tolerance, then the condensate composition is adjusted and the process is repeated until the specified accuracy is achieved. These two alternatives to the modified Rachford-Rice equation are not needed to solve the single liquid phase problems in this section. However, they are introduced here to show that they achieve the same results. They will also be used to solve problems with multiple liquid phases in section 4.2.4, which are not readily solved using the modified Rachford-Rice method.

All three options are illustrated in this section for a condenser with the same inlet stream. These illustrations use an inlet stream with three condensable components, but the procedures could be applied to any stream with two or more condensable components. A fourth illustration for a system with liquid that is not ideal is also presented in this section.

4.2.3.1 Option 1 – Modified Rachford-Rice Method

Including noncondensable in the inlet gas stream to a condenser complicates the determination of emissions from the condenser. Typically, the solubility of a noncondensable gas in the condensate that would form in the condenser is either very small or not known. One can simplify the problem by assuming that all of the noncondensable gas exits the vent device through the exit vapor stream and that none is contained in the exit condensate stream. If the solubility of the noncondensable gas in the condensate is set to 0.0, then $x_i = 0$, and K_i becomes infinity. When K_i equals infinity then the standard Rachford-Rice model becomes indeterminate since K_i appears in the numerator and the denominator. This problem may be solved by dividing both numerator and denominator by $(K_i - 1)$ as shown.

$$f\left(\frac{V}{F}\right) = \sum_{i=1}^c \frac{(K_i - 1)z_i}{1 + (K_i - 1)V/F} \quad \text{Eq. 4-9}$$

$$f\left(\frac{V}{F}\right) = \sum_{i=1}^c \left[\frac{(K_i - 1)z_i}{1 + (K_i - 1)V/F} \times \frac{1/(K_i - 1)}{1/(K_i - 1)} \right] \quad \text{Eq. 4-20}$$

$$f\left(\frac{V}{F}\right) = \sum_{i=1}^c \frac{z_i}{1/(K_i - 1) + V/F} \quad \text{Eq. 4-21}$$

For the case when component i is a noncondensable gas (nitrogen, air, etc) where $x_i = 0$ then:

$$K_i = \frac{y_i}{x_i} \quad \text{Eq. 4-10}$$

$$\lim_{x_i \rightarrow 0} [K_i] = \lim_{x_i \rightarrow 0} \left[\frac{y_i}{x_i} \right] = \infty \quad \text{Eq. 4-22}$$

The modified Rachford-Rice expression for the noncondensable component may now be evaluated as shown.

$$\lim_{K_i \rightarrow \infty} \left[\frac{z_i}{1/(K_i - 1) + V/F} \right]_{nc} = \left(\frac{z_i}{1/\infty + V/F} \right)_{nc} = \left(\frac{z_i}{V/F} \right)_{nc} \quad \text{Eq. 4-23}$$

Combining Eq. 4-21 (for the condensable components) with Eq. 4-23 (for the noncondensable components) leads to a modified Rachford-Rice equation that can be used to solve condenser problems when non-condensable components such as air or nitrogen are present in the process stream.

$$f\left(\frac{V}{F}\right) = \sum_{i=1}^{C_c} \frac{z_i}{1/(K_i - 1) + V/F} + \sum_{j=1}^{C_{nc}} \frac{z_j}{V/F} \quad \text{Eq. 4-24}$$

The derivative of the modified Rachford-Rice equation, with respect to V/F , is shown in Eq. 4-25 and can be applied within the framework of Newton's method using Eq. 4-15.

$$f'\left(\frac{V}{F}\right) = \frac{f(V/F)}{d(V/F)} = \sum_{i=1}^{C_c} \frac{-z_i}{[1/(K_i - 1) + V/F]^2} + \sum_{j=1}^{C_{nc}} \frac{-z_j}{[V/F]^2} \quad \text{Eq. 4-25}$$

$$\left(\frac{V}{F}\right)_{k+1} = \left(\frac{V}{F}\right)_k - \frac{f(V/F)}{f'(V/F)} \quad \text{Eq. 4-15}$$

After V/F is determined, the composition of each exit stream may be calculated using Eq. 4-11 through Eq. 4-14.

$$V = F (V/F) \quad \text{Eq. 4-11}$$

$$L = F - V \quad \text{Eq. 4-12}$$

$$x_i = \frac{z_i}{1 + (V/F)(K_i - 1)} \quad \text{Eq. 4-13}$$

$$y_i = x_i K_i \quad \text{Eq. 4-14}$$

Illustration 4-5: Modified Rachford-Rice Method for Vent Condenser

500 gallons of condensate from Illustration 4-4 was cooled to 30°C and is being held in a 1,000 gallon receiver. Methyl chloride, n-hexane, and toluene are assumed to be an ideal mixture. The vessel is under a nitrogen gas sweep of 1.0 scfm which is vented to a total condenser (standard conditions based on temperature of 0°C). The nitrogen off gas exits the condenser at 2°C and is assumed to be saturated for the purposes of this illustration (the actual saturation level could be determined using the procedure in illustration 3-8 in section 3.2.2). What would the emissions and the material balance for the condenser be over a one hour period under these conditions?

Step 1. Establish characteristics of the inlet gas stream.

An analysis of the process gas stream entering the condenser from the receiver is shown in Table 4-4.

Table 4-4. Analysis of the Condenser Inlet Feed Stream

Compound	F _i lb/hr	MWt	F _i lb-moles/hr	z _i Mole frac.	Partial pressure p _i mm Hg
Noncondensable					
nitrogen	4.68	28.01	0.1671	0.354	269
Condensable					
methyl chloride	12.67	50.49	0.2509	0.532	405
n-hexane	3.47	86.17	0.040252	0.0854	65
toluene	1.20	92.13	0.013006	0.0276	21
Totals			0.47126	1.0	760

Step 2. Check to confirm whether condensation will occur

Before proceeding to calculate the material balance for the vent condenser it's a good idea to perform a quick test to see if condensation is likely to occur in the condenser. In some cases the quantity of noncondensable gas component (air, nitrogen, etc) could be too high for condensation to occur.

For this test we can calculate x_i for each condensable component in hypothetical condensate at the condenser temperature (2°C in this example). If the sum of the calculated x_i values for all of the condensable components is greater than 1.0 then we can conclude that condensation will take place. However, if the sum of the calculated x_i values is less than 1.0 then condensation is not possible at the current condenser operating conditions.

$$x_i = \frac{P_i^{30^\circ C}}{\gamma_i P_i^{2^\circ C}} = \frac{P_i^{30^\circ C}}{P_i^{2^\circ C}} \quad \text{Eq. 4-26}$$

where P_i is the pure component vapor pressure at 2°C,

p_i is the component partial pressure at the condenser inlet conditions (30°C), and

γ_i is 1.0 for the ideal mixture.

The partial pressure p_i for each component in the inlet stream to the condenser was established in step 1. The pure component vapor pressure (P_i) for each component in the feed stream at 2°C has been calculated based on the Antoine Equation, and the resulting values are shown in Table 4-5. The hypothetical

condensate mole fraction for each component x_i has been calculated using Eq. 4-26 because the problem stated that the process mixture could be treated as ideal. All of the component mole fractions and the sum are shown in Table 4-5. The sum is greater than 1.0. Therefore, condensation will occur in this condenser.

Table 4-5. Check to See If Condensation Will Take Place at 2°C

	Inlet Partial Pres. (mm Hg)	P_i @ 2°C	x_i Estimated
Condensable			
methyl chloride	405	2,089	0.19
n-hexane	65	50	1.3
toluene	21	8	2.63
		$\sum x_i = 4.1$	

Step 3. Calculate Values to use in the Modified Rachford-Rice Equation

Values for z_i are needed for all four components; these values were established in step 1. Values for K_i are needed for methyl chloride, n-hexane, and toluene; a K value for nitrogen is ignored since it is now assumed that the solubility of nitrogen is 0. The K_i values are calculated using Eq. 4-10 with the pure component vapor pressures at 2°C, which were calculated in step 2. Table 4-6 shows all of the input data and the calculated K_i values.

Table 4-6. Preparation for Applying the Modified Rachford-Rice Method

Compound	F_i lb-moles/hr	z_i Mole frac.	P_i (mm Hg) 2°C	$K_i = P_i/P_{sys}$
nitrogen	0.1671	0.354	---	---
methyl chloride	0.2509	0.532	2,089	2.749
n-hexane	0.040252	0.0854	50	0.066
toluene	0.013006	0.0276	8	0.011
Totals		1		

Step 4. Add known values to the modified Rachford-Rice equation.

The modified Rachford-Rice equation (Eq. 4-24) is populated using K_i and z_i from Table 4-6. Note that a separate term is needed for each component in the inlet stream.

$$f\left(\frac{V}{F}\right) = \sum_{i=1}^{C_c} \frac{z_i}{1/(K_i - 1) + V/F} + \sum_{j=1}^{C_{nc}} \frac{z_j}{V/F}$$

$$0 = \frac{z_{mc}}{1/(K_{mc} - 1) + V/F} + \frac{z_h}{1/(K_h - 1) + V/F} + \frac{z_t}{1/(K_t - 1) + V/F} + \frac{z_{n2}}{V/F}$$

$$0 = \frac{0.532}{1/(2.749 - 1) + V/F} + \frac{0.0854}{1/(0.066 - 1) + V/F} + \frac{0.0276}{1/(0.011 - 1) + V/F} + \frac{0.354}{V/F}$$

Step 5. Add known values to the derivative of the modified Rachford-Rice equation.

The derivative of the modified Rachford-Rice equation (Eq. 4-25) is populated using the same data from Table 4-6.

$$f'(V/F) = \frac{f(V/F)}{d(V/F)} = \sum_{i=1}^{C_c} \frac{-z_i}{[1/(K_i - 1) + V/F]^2} + \sum_{j=1}^{C_{nc}} \frac{-z_j}{[V/F]^2}$$

$$f'(V/F) = \frac{-0.249}{(1/(2.749 - 1) + V/F)^2} + \frac{-0.301}{(1/(0.066 - 1) + V/F)^2} + \frac{-0.45}{(1/(0.011 - 1) + V/F)^2} + \frac{-0.354}{(V/F)^2}$$

Step 6. Solve for V/F using Newton's method.

An initial guess of V/F is needed to start the iterative process of solving the modified Rachford-Rice equation. Rather than picking a value arbitrarily, sometimes it's helpful to graphically plot $f(V/F)$ as a function of V/F as shown in Figure 4-4 for this problem. The objective is to identify the value of V/F where $f(V/F)$ is crossing the horizontal line where the y axis = 0. Using an initial value of V/F that is close to this point will help ensure that the method will converge on a valid solution. Newton's method relies on the slope of $f(V/F)$ to help locate the solution. At points where the slope of the function is sufficiently low the method has been known to extrapolate into areas that are out of bounds for the solution of V/F (i.e., less than 0 or greater than 1). This problem can be avoided by making an initial guess of V/F close to the value where the function crosses the x-axis. By inspection of Figure 4-4 one would know that the value of V/F that solves the Rachford-Rice equation for this condenser problem is close to 0.9.

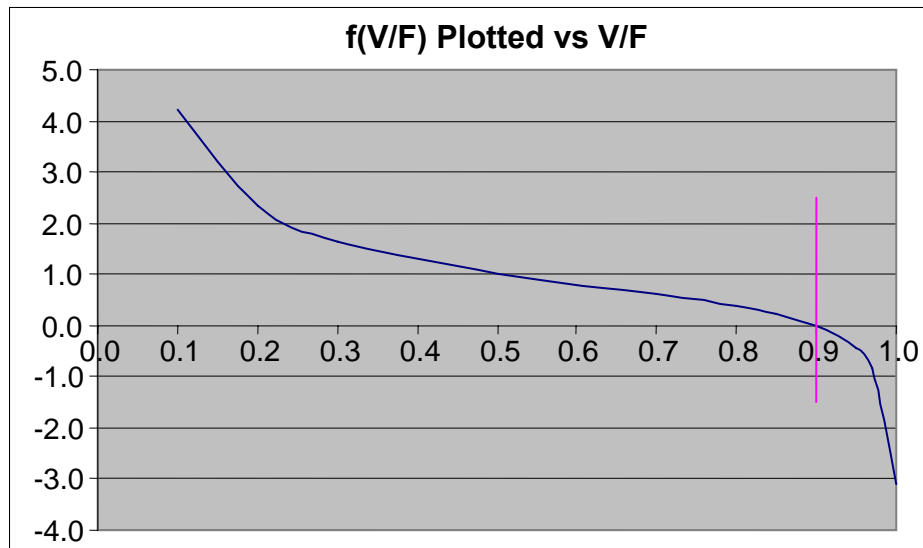

Figure 4-4. Rachford-Rice Plot showing solution at V/F = 0.90076.

Based on Figure 4-4, an initial guess for V/F was assumed to be 0.85. Newton's method as shown in Eq. 4-15 is applied until the V/F remains the same value within a 0.0001 tolerance, as determined using Eq. 4-17. The results of this iterative process are shown in Table 4-7. Inserting the initial guess for V/F in Eq. 4-24 and Eq. 4-25 resulted in initial estimates for $f(V/F)$ and $f'(V/F)$ of 0.23186 and -3.32408, respectively.

The next estimate of V/F was calculated using these values in Eq. 4-15, and the initial and second estimates were compared using Eq. 4-17. This process was repeated for four iterations. At that point the value of V/F had converged within the specified tolerance level.

Table 4-7. Iteration results for Illustration 4-5

Iteration	$(V/F)_k$	$f(V/F)$	$f'(V/F)$	$(V/F)_{k+1}$	$\left \frac{(V/F)_{k+1} - (V/F)_k}{(V/F)_k} \right $
1	0.85	0.23186	-3.32408	0.91975	0.08206
2	0.91975	-0.12876	-7.54609	0.90269	0.01855
3	0.90269	-0.01159	-5.85834	0.90071	0.00219
4	0.90071	0.00030	-5.70487	0.90076	0.00006

After V/F has been determined by trial and error, as shown in Table 4-7, then the molar flow rates of the exit liquid and vapor streams are calculated using Eq. 4-11 and Eq. 4-12.

$$\begin{aligned}
 V &= F (V/F) \\
 &= (0.47126)(0.90076) \\
 &= 0.42454 \text{ lb moles / hr}
 \end{aligned}$$

$$\begin{aligned}
 L &= F - V \\
 &= 0.47126 - 0.42454 \\
 &= 0.0467 \text{ lb moles / hr}
 \end{aligned}$$

The mole fractions of components in each exit stream are calculated using Eq. 4-13 and Eq. 4-14. For example, the mole fractions for methyl chloride are calculated as follows:

$$\begin{aligned}
 x_{mc} &= \frac{z_{mc}}{1 + (V/F)(K_{mc} - 1)} \\
 &= \frac{.532}{1 + (0.90076)(2.749 - 1)} \\
 &= 0.20676
 \end{aligned}$$

$$\begin{aligned}
 y_i &= x_i K_i \\
 &= (.20676)(2.749) \\
 &= 0.56831
 \end{aligned}$$

The molar flow rates of each component are calculated by multiplying the total moles by the applicable mole fractions. For example, the molar flow rates of methyl chloride are calculated as follows:

$$n_{mc,L} = (.20676)(.0467) = 0.00967 \text{ lb moles / hr}$$

$$n_{mc,V} = (.56831)(.42454) = 0.24127 \text{ lb moles / hr}$$

Finally, the mass flow rates for each component are calculated by multiplying the molar flow rates by the molecular weight of the component. The results of all of the calculations in step 7 are shown in Tables 4-8 and 4-9.

Table 4-8. Product Outlet Stream Analysis (mole fractions and rates in lb-moles)

	F_i lb-moles/hr	Z_i	K_i	L_i lb-moles/hr	X_i	V_i lb-moles/hr	Y_i
nitrogen	0.1671	0.354	---	0.00000	0	0.16708	0.39356
methyl chloride	0.2509	0.532	2.749	0.00967	0.20676	0.24127	0.56831
hexane	0.04025	0.0854	0.066	0.02521	0.53903	0.01506	0.03546
toluene	0.01301	0.0276	0.0276	0.01189	0.25417	0.00114	0.00268
Totals	0.47126			0.0467	0.99996	0.42454	1.00000

Table 4-9. Product Streams Analysis

Component	MW_t	F_i Inlet Stream lb/hr	L_i Condensate lb/hr	V_i Vapor Emissions lb/hr
nitrogen	28.01	4.6800	0.0000	4.6800
methyl chloride	50.49	12.6700	0.4883	12.1817
hexane	86.17	3.4700	2.1727	1.2973
toluene	92.13	1.2000	1.0954	0.1046
Totals		22.0200	3.7563	18.2637

Additional Considerations Regarding Numerical Convergence Techniques

It was mentioned earlier that Newton's method had the potential to extrapolate the search into places that are out of bounds with respect to a realistic solution. In some cases a damping factor may be used to improve the tendency for Newton's method to continually move toward the desired solution.

Additionally, other numerical methods exist including the False Position, Bisection, and Fibonacci Methods that can be applied to either the standard Rachford-Rice or the modified Rachford-Rice solution model. If it is desired to use standard spreadsheet software then the Goal Seek function can be applied to solve the condenser problem.

4.2.3.2 Option 2 – Partial Pressure Correction Method

A second approach to solving the vent condenser problem when two or more condensable components are present in the system involves making an initial guesstimate of the condensate composition and then placing the balance of the process in the vapor phase. Component vapor pressures are then calculated for

the condensate and compared to the component partial pressures of the vapor phase. Since equilibrium between the condensate liquid phase and the vapor phase is assumed, both partial pressures that have been calculated by different means should be the same for each component. The amount of each component in the condensate is adjusted up or down until the partial pressures are the same for each component (within an acceptable tolerance). Material balance accounting is assured since 100% of each component in the feed is allocated to be split between the condensate phase and the vapor phase.

Condensable component material balance:

$$n_{i,F} = n_{i,L} + n_{i,V} \quad \text{Eq. 4-27}$$

The partial pressure of each condensable component in the exit liquid stream may be calculated using Raoult's Law which may be extended with activity coefficients.

$$p_{i,L} = x_i \gamma_i P_i = \frac{n_{i,L} \gamma_i P_i}{L} \quad \text{Eq. 4-28}$$

The partial pressure of each condensable component in the exit gas phase may be calculated using Dalton's Law.

$$p_{i,V} = \frac{n_{i,V}}{V} P_{sys} = y_i P_{sys} \quad \text{Eq. 4-29}$$

At equilibrium both partial pressures should be the same for each condensable component.

$$p_{i,L} = p_{i,V} \quad \text{Eq. 4-30}$$

However, since we are making only an initial guesstimate, the two partial pressures will likely not be the same. An error of estimate can be calculated by subtracting one from the other.

$$f(n_i) = p_{i,L} - p_{i,V} \quad \text{Eq. 4-31}$$

Newton's method is applied to all condensable components simultaneously until the two partial pressures (from the condensate and the gas phase) agree within acceptable tolerance for each component.

$$n_{i,L,k+1} = n_{i,L,k} - \frac{f(n_{i,k})}{f'(n_{i,k})} \quad \text{Eq. 4-15}$$

$f'(n_i)$ may be approximated using the calculus of finite differences where only condensable component i is varied and the other components are held constant. [Constantinides]

$$f'(n_{i,L,k}) \cong \left[\frac{f(n_{i,L,k} + \delta) - f(n_{i,L,k} - \delta)}{2\delta} \right]_{T,P,j} = \left(\frac{\Delta p_i}{\Delta n_i} \right)_{T,P,j} \quad \text{Eq. 4-32}$$

If the process contains only two condensable components then Eq. 4-15 would be required for both components. If the process contains 5 condensable compounds then five separate equations would be

required and so on. For each equation $f(n_{i,L,k})$ and $f'(n_{i,L,k})$ are calculated with only n_i being varied while all other compound quantities held constant. Once $f(n_{i,L,k})$ and $f'(n_{i,L,k})$ have been calculated $n_{i,L,k+1}$ is calculated for each condensable compound in the system as shown.

$$\begin{array}{l}
 \text{Component 1} \\
 \text{Component 2} \\
 \vdots \\
 \text{Component n}
 \end{array}
 \left[\begin{array}{l}
 n_{1,L,k+1} = n_{1,L,k} - \frac{f(n_{1,L,k})}{f'(n_{1,L,k})_{T,P,j \neq 1}} \\
 n_{2,L,k+1} = n_{2,L,k} - \frac{f(n_{2,L,k})}{f'(n_{2,L,k})_{T,P,j \neq 2}} \\
 \bullet \\
 \bullet \\
 \bullet \\
 n_{n,L,k+1} = n_{n,L,k} - \frac{f(n_{n,L,k})}{f'(n_{n,L,k})_{T,P,j \neq n}}
 \end{array} \right]$$

Illustration 4-6: Partial Pressure Correction Method for Vent Condenser

500 gallons of the condensate from Illustration 4-4 was cooled to 30°C and is being held in a 1,000 gallon receiver. A 1.0 scfm nitrogen gas sweep enters that vessel headspace and exits fully saturated with vapors from the condensate. The condenser is operated so process gas stream exits at 2°C. What would the emissions and the material balance for the condenser be over a one hour period under these conditions?

Step 1. Establish characteristics of the inlet gas stream.

An analysis of the process gas stream entering the condenser from the receiver is shown in Table 4-10. This information is the same as for illustration 4-5.

Table 4-10. Analysis of the Condenser Inlet Feed Stream

Compound	F _i lb/hr	MWt	F _i lb-moles/hr	z _i Mole frac.	Partial Pressure mm Hg
Noncondensable					
nitrogen	4.68	28.01	0.1671	0.354	269
Condensable					
methyl chloride	12.67	50.49	0.2509	0.532	405
n-hexane	3.47	86.17	0.04025	0.0854	65
toluene	1.20	92.13	0.01301	0.0276	21
Totals			0.47126	1.0	760

Step 2. Check to confirm whether condensation will occur.

This procedure is presented in illustration 4-5 and is not repeated here.

Step 3. Make initial estimate of composition of condensate.

In setting up to solve this problem using Newton's method, it improves the efficiency of convergence if one first approximates of the molar composition of the condensate to as near to the final solution as possible before beginning the iteration process. Since the pure vapor pressure of toluene (8 mm Hg @ 2°C) is lower than the partial pressure of toluene in the feed stream (21 mm Hg) then all of the toluene moles can be placed in the condensate. Similarly, since the pure vapor pressure of n-hexane (50 mm Hg @ 2°C) is lower than the partial pressure of n-hexane in the feed (65 mm Hg) then all of the n-hexane moles in the condensate. However, the pure vapor pressure of methyl chloride (2089 mm Hg) at 2°C is greater than the inlet partial pressure of methyl chloride (405 mm Hg) and so only a fraction of the inlet moles should be allocated for the condensate.

If one assumes that the condensate will be an ideal mixture where the activity coefficient equals 1.0 for each component in the condensate, then an initial guess for the concentration of methyl chloride can be estimated using Eq. 4-8, where x_i is the mole fraction of methyl chloride that would be needed in the liquid to result in the partial pressure of 405 mmHg.

$$x_i = \frac{p_i^{feed}}{\gamma_i P_i^{2^\circ C}} = \frac{405}{1 * 2089} = 0.19 \quad \text{Eq. 4-8}$$

Once x_i is known, then the moles of methyl chloride that should be allocated to the liquid condensate can be calculated by the ratio of the methyl chloride mole fraction and the non methyl chloride portion of the condensate as shown in Eq. 4-33, where j represents n-hexane and toluene.

$$\begin{aligned} n_{i,L} &\approx \frac{x_i}{1 - x_i} * n_{j,L} \\ &= \frac{0.19}{1 - 0.19} * 0.0533 \\ &= 0.01249 \text{ lb moles / hr} \end{aligned} \quad \text{Eq. 4-33}$$

The resulting initial estimate of the condensate is presented in Table 4-11.

Table 4-11. Initial Estimate of Condensate

Compound	F _i lb-moles/hr	p _i at Feed mm Hg	P _i at 2°C mm Hg	L _i , estimated lb-moles/hr
Noncondensable				
nitrogen	0.1671	269		
Condensable				
methyl chloride	0.2509	405	2,089	0.01249
n-hexane	0.04025	65	50	0.04025
toluene	0.01301	21	8	0.01301
totals				0.06575

Step 4. Solve for the partial pressures using Newton-Raphson method to iterate on the number of moles of each component in the condensate.

Once an initial guess of the condensate has been made, then the iterative processing can begin as shown below. For the first iteration, the mole fraction of each compound in the liquid is calculated based on the initial composition from Table 4-11. For example, the mole fraction for toluene is estimated as $0.01301/0.06575 = 0.2$. The partial pressure based on this liquid composition and the pure component vapor pressure at 2°C is calculated using Eq. 4-28. For example, the calculation is as follows for toluene:

$$\begin{aligned} P_{i,L} &= x_i \gamma_i P_i \\ &= (0.2)(1)(8) \\ &= 1.6 \text{ mm Hg} \end{aligned}$$

For the first iteration, the vapor out of the condenser is assumed to consist of only nitrogen and methyl chloride. The amount of methyl chloride in the outlet vapor is estimated as the difference between the methyl chloride in the feed and the methyl chloride in the condensate. The mole fractions are estimated based on the total number of moles of nitrogen and methyl chloride in the outlet vapor stream. The partial pressures are then estimated using Eq. 4-29. For example, the calculation is as follows for methyl chloride in the first iteration:

$$\begin{aligned} p_{i,V} &= y_i P_{sys} \\ &= (0.59)(760) \\ &= 447 \text{ mmHg} \end{aligned}$$

The difference in the partial pressures (i.e., the function) is calculated using Eq. 4-31. For methyl chloride:

$$\begin{aligned} f(n_i) &= p_{i,L} - p_{i,V} \\ &= 397 - 447 \\ &= -50 \text{ mmHg} \end{aligned}$$

The derivative of the function is estimated using finite differences as described in Eq. 4-32. This means the calculations of the partial pressures described above need to be repeated using slightly different estimates of the number of moles in the condensate. In this illustration the δ used in Eq. 4-32 was equal to 0.05 percent of the original estimate of the number of moles in the condensate. For example, for methyl chloride in the first iteration the calculations were repeated using 0.012484 lbmoles and 0.012496 lbmoles (i.e., $\delta = 0.0005 \times 0.01249 = 0.000006245$). Using these values for n_i results in $f(n_i)$ equal to -50.188 and -49.857, respectively. The difference between these values (0.331) is the numerator in Eq. 4-32, and 0.00001249 is the denominator. Dividing 0.331 by 0.00001249 results in 26,507 for the derivative of the function. This process is repeated for all of the other components in the condensate. The numerical values are not tabulated in this document due to space considerations.

The number of moles of each component in the condensate for the second iteration is estimated using Eq. 4-15. For example, the next second estimate for methyl chloride is estimated as follows:

$$\begin{aligned}
 n_{i,L,k+1} &= n_{i,L,k} - \frac{f(n_{i,k})}{f'(n_{i,k})} \\
 &= 0.01249 - \frac{-50}{26,507} \\
 &= 0.0144 \text{ lb moles / hr}
 \end{aligned}$$

This process is continued until the difference in the partial pressures estimated based on the liquid and vapor moles fractions for all components agree within an acceptable level of tolerance. For this illustration the analysis stopped after 7 iterations, when the differences in vapor pressures for all compounds appeared to be in good agreement for all compounds. One can calculate the percent agreement for each component by dividing Δp_i by the average of both partial pressures. For Iteration 7 the % agreement is shown in Table 4-12.

Iteration 1

Compound	$n_{i,L,k}$	x_i	$p_{i,L}$	V_i	y_i	$p_{i,v}$	Δp_i	$\Delta p_i/\Delta n_i$	$n_{i,L,k+1}$
nitrogen	0			0.167	0.41	313	N/A	N/A	N/A
methyl chloride	0.01249	0.19	396.91	0.238	0.59	446.82	-50.2	26507	0.0144
n-hexane	0.04025	0.61	30.6	0	0	0	30.6	2169.6	0.0261
toluene	0.01301	0.2	1.6	0	0	0	1.6	1972.3	0.0122

Iteration 2

Compound	$n_{i,L,k}$	x_i	$p_{i,L}$	V_i	y_i	$p_{i,v}$	Δp_i	$\Delta p_i/\Delta n_i$	$n_{i,L,k+1}$
nitrogen	0			0.167	0.41	313	N/A	N/A	N/A
methyl chloride	0.0144	0.27	570	0.237	0.57	430	140	29609	0.0096
n-hexane	0.0261	0.5	24.8	0.014	0.03	25.6	-0.8	2233.1	0.0265
toluene	0.0122	0.23	1.9	8E-04	0	1.5	0.4	1929.4	0.012

Iteration 3

Compound	$n_{i,L,k}$	x_i	$p_{i,L}$	V_i	y_i	$p_{i,v}$	Δp_i	$\Delta p_i/\Delta n_i$	$n_{i,L,k+1}$
nitrogen	0			0.1671	0.395	300.2	N/A	N/A	N/A
methyl chloride	0.00964	0.2	418.3	0.2413	0.57	433.4	-15	35464.5	0.01007
n-hexane	0.02651	0.551	27.5	0.0137	0.032	24.7	2.9	2205	0.02522
toluene	0.012	0.249	2	0.001	0.002	1.8	0.2	1917.1	0.0119

Iteration 4

Compound	$n_{i,L,k}$	x_i	$p_{i,L}$	V_i	y_i	$p_{i,v}$	Δp_i	$\Delta p_i/\Delta n_i$	$n_{i,L,k+1}$
nitrogen	0			0.1671	0.394	299.5	N/A	N/A	N/A
methyl chloride	0.01007	0.213	445.6	0.2408	0.568	299.5	14	35598.2	0.00967
n-hexane	0.02522	0.534	26.7	0.015	0.035	26.9	-0.22	2222.3	0.02532
toluene	0.0119	0.252	2	0.0011	0.003	2	0.04	1914.7	0.01188

Iteration 5

Compound	$n_{i,L,k}$	x_i	$p_{i,L}$	V_i	y_i	$p_{i,v}$	Δp_i	$\Delta p_i/\Delta n_i$	$n_{i,L,k+1}$
nitrogen	0			0.1671	0.394	299.2	N/A	N/A	N/A
methyl chloride	0.00967	0.206	431.1	0.2412	0.568	432	-0.9	36143.2	0.0097
n-hexane	0.02532	0.54	27	0.0149	0.035	26.7	0.26	2218.7	0.0252
toluene	0.01188	0.253	2	0.0011	0.003	2	0.01	1913.9	0.01187

Iteration 6

Compound	$n_{i,L,k}$	x_i	$p_{i,L}$	V_i	y_i	$p_{i,v}$	Δp_i	$\Delta p_i/\Delta n_i$	$n_{i,L,k+1}$
nitrogen	0			0.1671	0.394	299.2	N/A	N/A	N/A
methyl chloride	0.0097	0.207	433.1	0.2412	0.568	431.8	1.29	36176.4	0.00966
n-hexane	0.0252	0.539	26.9	0.0151	0.035	27	-0.01	2220.4	0.0252
toluene	0.01187	0.254	2	0.0011	0.003	2	0	1913.7	0.01187

Iteration 7

Compound	$n_{i,L,k}$	x_i	$p_{i,L}$	V_i	y_i	$p_{i,v}$	Δp_i	$\Delta p_i/\Delta n_i$	$n_{i,L,k+1}$
nitrogen	0			0.1671	0.394	299.2	N/A	N/A	N/A
methyl chloride	0.00966	0.207	431.9	0.2412	0.568	431.9	-0.03	36228.9	0.00966
n-hexane	0.0252	0.539	26.96	0.0151	0.035	26.94	0.024	2220.1	0.02519
toluene	0.01187	0.254	2.03	0.0011	0.003	2.03	0.001	1913.6	0.01187

Table 4-12. Convergence Determination

Component	p_i avg. mm Hg	Δp_i mm Hg	$\Delta p_i/p_i$ %
nitrogen		N/A	N/A
methyl chloride	431.86	-0.03	-0.007%
n-hexane	26.95	0.02	0.089%
toluene	2.031	0.001	0.049%

Step 5. Perform material balance check.

The final results after Iteration 7 are presented in Table 4-13 with the material balance displayed in pound moles and in pounds for the exit vapor and liquid streams. The composition of the exit vapor streams is also listed by the average partial pressure for each component being emitted.

Table 4-13. Material Balance for Condenser

Compound	MWt	F _i lb/hr	F _i lb- moles/ hr	L _i lb- moles/ hr	L _i lb/hr	V _i lb- moles/hr	V _i lb/hr	P _i mm Hg
nitrogen	28.01	4.68	0.167	0		0.167	4.68	299.2
methyl chloride	50.49	12.67	0.251	0.0097	0.49	0.241	12.18	431.86
n-hexane	86.17	3.47	0.040	0.0252	2.17	0.015	1.30	26.95
toluene	92.13	1.20	0.013	0.0118	1.09	0.001	0.11	2.031
Totals		22.02	0.471	0.0467	3.75	0.424	18.27	760.04

The results from the Pressure Balance Method for this problem are virtually identical to the results that were obtained using the Modified Rachford-Rice Method shown in Illustration 4-5.

4.2.3.3 Option 3 – Material Balance Correction Method

A third approach to solving the vent condenser problem when two or more condensable components are present involves making an initial guesstimate of the liquid condensate composition. Component vapor pressures are then calculated for the condensate and used in conjunction with the noncondensable component to estimate the amount of each component that exists in the vapor space. For each condensable component, the moles in the liquid phase are added to the moles that have been calculated to exist in the vapor phase and the ratio between these two quantities is calculated. The moles of each component in the liquid phase are then corrected by the ratio value for the next iteration. For example, if the moles of component *i* in the outgoing vapor and liquid streams is calculated to be 20% greater than the moles of component *i* in the incoming feed stream then the amount of *i* in the condensate is divided by 1.2 for the next iteration. This iterative process for correcting the moles of *i* in the liquid phase continues until the material balance for all components is in agreement within acceptable tolerances. For any condenser, the inlet stream must equal the sum of the exit vapor and the liquid condensate at steady state operation.

Material Balance Considerations

Overall material balance:
$$F = L + V \quad \text{Eq. 4-34}$$

A material balance can be written for each condensable component in the process as shown in Eq. 4-35.

Balance of condensable components:
$$z_i F = x_i L + y_i V \quad \text{Eq. 4-35}$$

$$n_{i,F} = n_{i,L} + n_{i,V} \quad \text{Eq. 4-36}$$

Assuming that all of the noncondensable gases (air, nitrogen, etc) exit the condenser in the vapor stream then Eq. 4-35 and Eq. 4-36 can be easily simplified. The moles of noncondensable n_{nc} in the exit gas stream are equal to the moles that are contained in the inlet stream.

Noncondensable component:
$$n_{nc,V} = z_{nc} F = y_{nc} V \quad \text{Eq. 4-37}$$

Equilibrium Considerations

The vapor pressure of each condensable component in the exit liquid stream can be calculated using Raoult's Law and extended with activity coefficients.

$$p_i = x_i \gamma_i P_i \quad \text{Eq. 4-38}$$

At steady state conditions, the moles of each condensable component i in the exit gas stream can be calculated from the vapor pressure of component i in the liquid, the partial pressure of the noncondensable in the exit gas, and the moles of the noncondensable component as shown.

$$\frac{n_{i,V}}{n_{nc,V}} = \frac{p_i}{p_{nc}} \quad \text{Eq. 4-39}$$

$$n_{i,V} = n_{nc} \frac{p_i}{p_{nc}} = n_{nc} \frac{x_i \gamma_i P_i}{p_{nc}} = n_{nc} \frac{n_{i,L} \gamma_i P_i}{L p_{nc}} \quad \text{Eq. 4-40}$$

If the process contains only a single condensable component then Eq. 4-40 can be applied directly to calculate the exit gas emissions from the condenser. This was shown in Illustrations 4-1, 4-2, and 4-3.

Combining Material Balance and Equilibrium Considerations

If the process contains two or more condensable components then a trial and error approach will be needed to determine the moles of each condensable component in the liquid and vapor phases. The equilibrium relationship (Eq. 4-40) can be combined with the material balance (Eq. 4-36) to result in a single expression that must hold true at single stage steady state conditions where equilibrium exist between each component in the liquid and vapor phase.

$$n_{i,F} = n_{i,L} + n_{i,V} = n_{i,L} + n_{nc} \frac{p_i}{p_{nc}} \quad \text{Eq. 4-41}$$

Eq. 4-41 ties the material balance and the equilibrium relationships together for each condensable component in the system and is independent of the number of condensable components present.

Description of the Basic Material Balance Correction Procedure

In the trial and error approach that follows, an educated guess of the condensate liquid is made. Eq. 4-41 is used to calculate the molar inventory of component i from the condensate and calculated vapor phase. Eq. 4-42 is then used to calculate the ratio Φ_i between the moles of component i in the feed and the moles calculated to be in the exit vapor and liquid phases. At steady state and equilibrium conditions Φ_i must equal 1.0.

$$\frac{n_{i,L} + n_{i,V}}{n_{i,F}} = \phi_i \quad \text{Eq. 4-42}$$

$$\frac{1}{\phi_i} \left(n_{i,L} + n_{i,L} \frac{n_{nc} \gamma_i P_i}{p_{nc} L} \right) \approx n_{i,F} \quad \text{Eq. 4-43}$$

$$\frac{n_{i,L}}{\phi_i} \left(1 + \frac{n_{nc} \gamma_i P_i}{p_{nc} L} \right) \approx n_{i,F} \quad \text{Eq. 4-44}$$

$n_{i,L,k+1}$ is estimated by dividing $n_{i,L,k}$ by Φ_i as shown in Eq. 4-45 and applied to the next iteration until Φ_i becomes close to 1.0 within an acceptable tolerance. It should be noted that L are the total moles of condensate in the system which includes component i. For this reason Eq. 4-44 and Eq. 4-45 are approximations which narrow as the iterative process converges.

$$n_{i,L,k+1} = \frac{n_{i,L,k}}{\phi_{i,k}} \quad \text{Eq. 4-45}$$

For each condensable component in the inlet stream, the following steps are followed until the error of estimate for each component has fallen within an acceptable tolerance.

Basic Procedures

An initial guesstimate of the condensate liquid must be made before the iteration process is started. One approach involves partitioning the moles of component i in the liquid using a measure of the relative volatility. Components having the greatest volatility will tend to concentrate in the vapor phase while compounds with the lowest volatility will tend to concentrate in the liquid phase.

$$v_i = \frac{P_i}{\sum_{j=1}^N P_j} \quad \text{Eq. 4-46}$$

The moles of component $n_{i,L}$ in the condensate liquid are calculated by multiplying the moles of $n_{i,F}$ in the feed by $(1 - v_i)$ since $(1 - v_i)$ would be a fraction of a compound to remain in the liquid phase.

$$(n_{i,L})_k = (1 - v_i) * n_{i,F} \quad \text{Eq. 4-47}$$

Also, $p_{nc,k}$ is set equal to the partial pressure of the noncondensable as contained in the feed stream $p_{nc,F}$. This is because we know that any condensation to occur will lead to value of p_{nc} that is greater than what we started with. So the noncondensable component partial pressure at the inlet feed is considered to be lowest starting value possible and can only become larger as the convergence takes place.

Step 1. Calculate L, x_i , and p_i for each component in the liquid phase.

$$L = \sum n_{i,L}, \quad x_i = \frac{n_{i,L}}{L}, \quad p_i = x_i \gamma_i P_i$$

Step 2. Calculate $n_{i,L,k+1}$ for each condensable component in the vapor phase and calculate V_{k+1} from the sum of the moles of condensable components in the vapor phase plus the noncondensable moles (which remain constant).

$$n_{i,V,k+1} = n_{nc,k} \frac{p_{i,k}}{p_{nc,k}} \quad V_{k+1} = \sum_{j=1}^C n_{j,V,k+1} + n_{nc}$$

Step 3. Calculate $p_{nc,k}$.

$$P_{nc,k+1} = \frac{n_{nc}}{V_{k+1}} P_{sys}$$

Step 4. Calculate Φ_i for each condensable component using Eq. 4-39 substituted in Eq. 4-42.

$$\frac{\left(n_{i,L} + n_{nc} \frac{p_i}{P_{nc,k+1}} \right)}{n_{i,F}} = \phi_{i,k+1}$$

Step 5. Calculate the next iteration value for $(n_{i,L})_{k+1}$.

$$(n_{i,L})_{k+1} = \frac{(n_{i,L})_k}{\phi_{k+1}}$$

Step 6. Repeat Steps 1 through 5 until Φ is between 0.999 and 1.001 for all condensable components in the system.

Illustration 4-7: Material Balance Correction Method for Vent Condenser

500 gallons of the condensate from Illustration 4-4 was cooled to 30°C and is being held in a 1,000 gallon receiver. A 1.0 scfm nitrogen gas sweep enters that vessel headspace and exits fully saturated with vapors from the condensate. The condenser is operated so process gas stream exits at 2°C. What would the emissions and the material balance from condenser be over a one hour period under these conditions?

Table 4-14. Analysis of the Condenser Inlet Feed Stream

Compound	F_i lb/hr	MWt	F_i lb-moles/hr	z_i Mole frac.	Partial Pressure mm Hg
Noncondensables					
nitrogen	4.68	28.01	0.1671	0.354	269
Condensables					
methyl chloride	12.67	50.49	0.2509	0.532	405
n-hexane	3.47	86.17	0.040252	0.0854	65
toluene	1.20	92.13	0.013006	0.0276	21
Totals					

Solution

The efficiency of convergence is always improved if one first approximates of the molar composition of the condensate that might be close to the final composition as an initial guess.

Table 4-15. Initial Estimate of Condensate

Compound	Pi, mm Hg	v_i	$1 - v_i$	$n_{i,F}$	$n_{i,L}$	x_i
methyl chloride	2089	0.9730	0.0270	0.2509	0.0068	0.115
n-hexane	50	0.0233	0.9767	0.040252	0.0393	0.666
toluene	8	0.0037	0.9963	0.013006	0.0130	0.219
Totals	2147	1.0000			0.0591	

Iteration 1

Components	Fi lb-m	$n_{i,L}$ lb-m	Xi fraction	Pi mm Hg	Vi lb-m	Yi fraction	Li+Vi lb-m	ϕ (Li+Vi)/Fi lb-m	$n_i, k+1$
nitrogen	0.1670			269.00	0.1670	0.4942	0.1670	1.0000	
methyl chloride	0.2509	0.0068	0.1151	240.36	0.1492	0.4415	0.1560	0.6218	0.0109
n-hexane	0.0403	0.0393	0.6650	33.25	0.0206	0.0611	0.0599	1.4892	0.0264
toluene	0.0130	0.0130	0.2200	1.76	0.0011	0.0032	0.0141	1.0835	0.0120
Totals		0.0591	1.0000	544.37	0.3380	1.0000		$P_{nc,k+1} =$	375.56

Iteration 2

Components	Fi lb-m	$n_{i,L}$ lb-m	Xi fraction	Pi mm Hg	Vi lb-m	Yi fraction	Li+Vi lb-m	ϕ (Li+Vi)/Fi lb-m	$n_i, k+1$
nitrogen	0.1670			375.56	0.1670	0.4330	0.1670		
methyl chloride	0.2509	0.0109	0.2217	463.14	0.2059	0.5339	0.2169	0.8644	0.0127
n-hexane	0.0403	0.0264	0.5351	26.75	0.0119	0.0308	0.0383	0.9512	0.0277
toluene	0.0130	0.0120	0.2432	1.95	0.0009	0.0022	0.0129	0.9890	0.0121
		0.0493	1.0000	867.39	0.3857	1.0000		$P_{nc,k+1} =$	329.06

Iteration 3

Components	Fi lb-m	$n_{i,L}$ lb-m	Xi fraction	Pi mm Hg	Vi lb-m	Yi fraction	Li+Vi lb-m	ϕ (Li+Vi)/Fi lb-m	$n_i, k+1$
nitrogen	0.1670			329.06	0.1670	0.3824	0.1670		
methyl chloride	0.2509	0.0127	0.2408	503.11	0.2553	0.5847	0.2680	1.0681	0.0118
n-hexane	0.0403	0.0277	0.5282	26.41	0.0134	0.0307	0.0411	1.0223	0.0271
toluene	0.0130	0.0121	0.2309	1.85	0.0009	0.0021	0.0131	1.0048	0.0121
		0.0525	1.0000	860.43	0.4367	1.0000		$P_{nc,k+1} =$	290.65

Iteration 20

Components	F _i lb-m	n _{i,L} lb-m	X _i fraction	P _i mm Hg	V _i lb-m	Y _i fraction	Li+Vi lb-m	ϕ (Li+Vi)/F _i lb-m	n _{i, k+1}
nitrogen	0.1670			298.81	0.1670	0.3931			
methyl chloride	0.2509	0.0097	0.2070	432.33	0.2416	0.5688	0.2513	1.0016	0.0097
n-hexane	0.0403	0.0252	0.5391	26.96	0.0151	0.0355	0.0403	1.0006	0.0252
toluene	0.0130	0.0119	0.2539	2.03	0.0011	0.0027	0.0130	1.0001	0.0119
		0.0468	1.0000	760.13	0.4248	1.0000		P _{nc,k+1} =	298.76

Iteration 21

Components	F _i lb-m	n _{i,L} lb-m	X _i fraction	P _i mm Hg	V _i lb-m	Y _i fraction	Li+Vi lb-m	ϕ (Li+Vi)/F _i lb-m	n _{i, k+1}
nitrogen	0.1670			298.76	0.1670	0.3933			
methyl chloride	0.2509	0.0097	0.2068	431.94	0.2414	0.5686	0.2511	1.0008	0.0097
n-hexane	0.0403	0.0252	0.5392	26.96	0.0151	0.0355	0.0403	1.0003	0.0252
toluene	0.0130	0.0119	0.2540	2.03	0.0011	0.0027	0.0130	1.0001	0.0119
		0.0467	1.0000	759.69	0.4247	1.0000		P _{nc,k+1} =	298.88

After Iteration 21, all component values for ϕ are between 0.999 and 1.001 and imply that the maximum molar change that each condensable component undergoes between iterations is smaller than 0.1%, as shown in Table 4-16.

Table 4-16. Convergence Determination

Component	ϕ (Li+Vi)/F _i	(ϕ -1)%
nitrogen		
methyl chloride	1.0008	0.08%
n-hexane	1.0003	0.03%
toluene	1.0001	0.01%

The final results after Iteration 21 are presented in Table 4-17 with the material balance displayed in pound moles (lb-m) and in pounds (lb) for the exit vapor and liquid streams. The composition of the exit vapor streams is also listed by the average partial pressure for each component being emitted.

Table 4-17. Material Balance for Condenser

Compound	MWt	n _{i,F} lb-m/hr	F _i lb/hr	n _{i,L} lb-m/hr	Li lb/hr	n _{i,V} lb-m/hr	V _i lb/hr	p _i mm Hg
nitrogen	28.01	0.167	4.68	0		0.1670	4.68	298.76
methyl chloride	50.49	0.251	12.67	0.0097	0.49	0.2414	12.18	431.94
n-hexane	86.17	0.040	3.47	0.0252	2.17	0.0151	1.30	26.96
toluene	92.13	0.013	1.20	0.0119	1.09	0.0011	0.11	2.03

Totals		0.471	22.02	0.0468	3.75	0.4247	18.27	759.69
--------	--	-------	-------	--------	------	--------	-------	--------

The results from the Material Balance Correction Method for this problem are very near the results that were obtained for the same problem using the Modified Rachford-Rice Method (Illustration 4-5) and the Partial Pressure Correction Method (Illustration 4-6).

4.2.3.4 Non-ideal Liquid

If a process mixture is known to exhibit non-ideal behavior then this specific information can be used within the condenser modeling framework.

Illustration 4-8: Vent condenser with azeotrope, material balance correction method.

A vent condenser, operating at 18.7°C, is used in an atmospheric distillation involving ethyl acetate and ethanol. The process vent stream to the vent condenser is at 30°C and contains ethyl acetate (1.10 lb/hr), ethanol (1.30 lb/hr), and nitrogen (1.56 lb/hr).

[Hougen, Watson, & Ragatz].

Ethyl acetate and ethanol are known to exhibit a minimum boiling point azeotrope with a composition of 73.4 % ethyl acetate and 26.6% ethanol (concentrations in mole percent) at the 18.7°C temperature.

Estimate the discharge vent emissions from the condenser.

Data Provided

Pure component vapor pressure and other conditions:

$P_{\text{ethyl acetate}}$	66.19 mm Hg	18.7°C
P_{ethanol}	36.36 mm Hg	18.7°C
P_{system}	760 mm Hg	discharge pressure
Time	1 hr	time for event

Inlet process stream to the condenser:

Compound	Rate (lb/hr)	Molecular Weight
Nitrogen	1.56 lb/hr	28.013
Ethyl Acetate	1.10 lb/hr	88.10
Ethanol	1.30 lb/hr	46.07

Azeotrope Data

Temperature	18.7°C	
Ethyl Acetate	0.734	mole fraction
Ethanol	0.266	mole fraction
Total Vapor Pressure	77.4 mm Hg	ethyl acetate + ethanol

Combined Inlet Material Flow to Condenser

The combined inlet streams to the condenser are analyzed using standard gas property relationships:

$$\beta = \left[1 + \frac{0.734 \ln(1.16)}{0.266 \ln(2.13)} \right]^2 \ln(2.13) = 1.797$$

$$\ln \gamma_1 = \frac{1.202}{\left[1 + \frac{1.202 x_1}{1.797 x_2} \right]^2} \quad \ln \gamma_2 = \frac{1.797}{\left[1 + \frac{1.797 x_2}{1.202 x_1} \right]^2} \quad \text{Eq. 4-51}$$

Where

$$\gamma_1 = \exp(\ln \gamma_1) \quad \gamma_2 = \exp(\ln \gamma_2) \quad \text{Eq. 4-12}$$

Activity coefficients and vapor pressures for ethyl acetate and ethanol are calculated and plotted in Figure 4-5 and Figure 4-6.

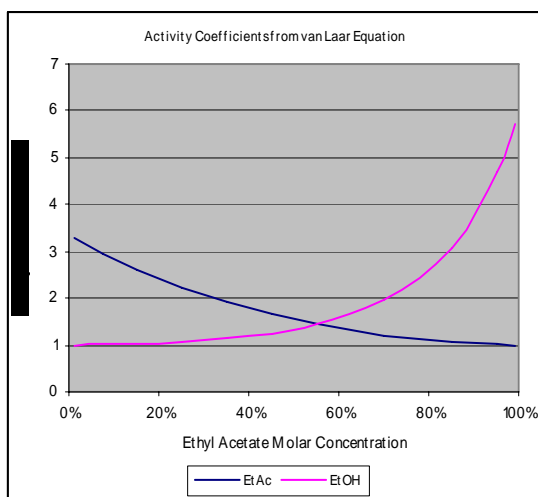

Figure 4-5. Activity coefficients calculated for ethyl acetate and ethanol from the van Laar equation for the complete composition range.

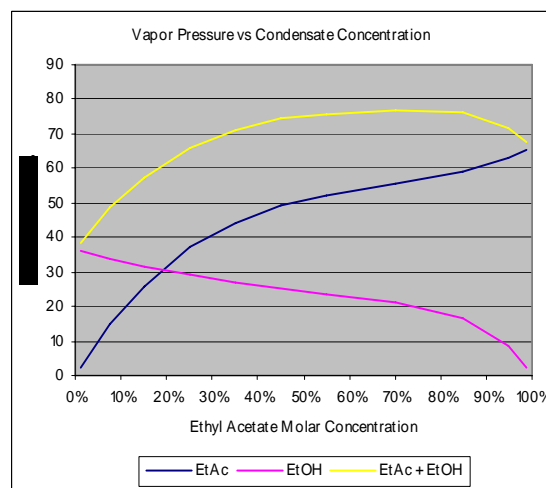

Figure 4-6. Component vapor pressures calculated for ethyl acetate and ethanol based on liquid composition, activity coefficients, and pure component vapor pressures.

Testing for condensation

For this problem, the inlet process stream at the vent condenser has been analyzed and is shown in Table 4-18. A van Laar equation has been developed based on the known azeotrope properties of the ethyl acetate and ethanol mixture (Figure 4-5) and can now be used to estimate component vapor pressures at different condensate compositions (Figure 4-6).

One problem that exists for completing a mathematical test for condensation is that the values of the activity coefficients corresponding vapor pressures for ethyl acetate and ethanol are not known since the composition of the liquid condensate is not initially known. However, if condensation is to occur then the first drop of condensate formed would be at equilibrium with the process vapor phase at the vent condenser conditions. Therefore, the composition of the first drop of condensate would have the same vapor pressure composition as the vapor stream from the process. Since a van Laar model has been established for the ethyl acetate – ethanol system then it is possible to back calculate the equilibrium

condensate composition assuming that the dew point for the process vapor stream is reached at the 18.7°C. The vapor composition for the ethyl acetate-ethanol system was calculated based on the thermodynamic model Eq. 4-51 and is plotted as a function of the liquid composition in Figure 4-7. This plot represents the equilibrium relationship between the vapor and the corresponding liquid and provides a convenient way to gauge the composition of the condensate at dew point conditions for the inlet condenser stream.

The partial pressures of ethyl acetate and ethanol at the condenser inlet conditions are used to calculate the relative mole fractions of ethyl acetate and ethanol that would exist at dew point conditions. These calculations are shown in Table 4-19 where the relative ethyl acetate concentration is 0.307 or 30.7%.

Table 4-19. Calculated Mole Fractions for Only the Condensable Portion of the Inlet Process Vapor Stream

Compound	p_i mm Hg	y_i Condensables
Ethyl Acetate	98.445	0.307
Ethanol	222.485	0.693
Totals	320.930	1.000

We are interested in locating the point on the plot in Figure 4-7 where $y = 30.67\%$ ethyl acetate that corresponds to the condensable composition of the inlet process vapor phase from Table 4-19. The x coordinate at the intercept corresponds to the initial condensate composition at the vapor dew point. By inspection, this value is between 7% and 8% ethyl acetate. Alternatively, it is possible to use a goal seek routine in a spreadsheet to back calculate the condensate concentration at dew point as 7.66% (mole/mole) ethyl acetate.

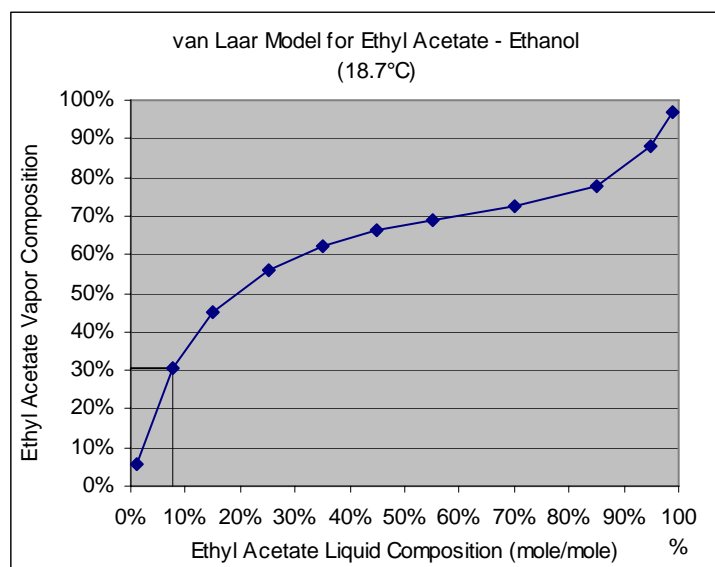

Figure 4-7. Ethyl acetate vapor composition plotted as a function of ethyl acetate composition in the liquid.

The condensation test can now be completed using the following relationships.

$$\left[\sum_{i=1}^n x_i = \sum_{i=1}^n \frac{P_i}{\gamma_i P_i} < 1.0 \right]_{\text{liq phase}} \quad \left[\sum_{i=1}^n x_i = \sum_{i=1}^n \frac{P_i}{\gamma_i P_i} \geq 1.0 \right]_{\text{liq phase}}$$

No Condensation Present

Condensation Present

Results from this analysis are shown in Table 4-20.

Table 4-20. Condensate Feasibility Analysis

	Inlet Partial Pressure (mm Hg)	Activity Coefficient	Pure Component Vapor Pressure mm Hg@ 18.7°C	Mole Fraction $x_i = \frac{P_i}{\gamma_i P_i}$
Ethyl Acetate	98.445	2.945374	66.19	0.50
Ethanol	222.485	1.004975	36.36	6.09
				$\sum_{i=1}^n x_i = 6.59$

The sum of the theoretical liquid phase mole fractions for the condensate is 6.59 and therefore, one can assume that condensation will take place in the vent condenser.

Solving for a single phase condensate using the Material Balance Correction Method

In the material balance correction method, the total amount of each component leaving the single stage device in liquid and vapor form is divided by the amount of that same component that is entering the device. The moles of each component in the condensate are corrected by the resulting ratio to obtain the corrected value to use for the next iteration, k+1.

$$\frac{n_{i,L} + n_{i,V}}{n_{i,F}} = \phi_i \quad \text{Eq. 4-53}$$

$$n_{i,L,k+1} = \frac{n_{i,L,k}}{\phi_{i,k}} \quad \text{Eq. 4-54}$$

Eq. 4-53 and Eq. 4-54 are repeated until the error of estimate for each component has fallen within an acceptable tolerance.

The iteration results for the vent condenser problem are presented in Table 4-21. The initial guess for the condensate was set equal to the composition of the inlet gas stream.

Table 4-21. Iterative Solution to Determine Condensate Composition

Iteration 1	n_i	x_i	γ_i	p_i	$n_{i,v}$	$n_{i,L+v}$	$n_{i,F}$	Φ^{-1}	$n_{i,k+1}$
Nitrogen				690.8	0.05569	0.05569	0.0557	1.0000	0.05569
EtAC	0.01249	0.3067	2.047	41.6	0.00335	0.01584	0.0125	0.7884	0.00984
EtOH	0.02822	0.6933	1.098	27.7	0.00223	0.03045	0.0282	0.9267	0.02615

Iteration 2	n_i	x_i	γ_i	p_i	$n_{i,v}$	$n_{i,L+v}$	$n_{i,F}$	Φ^{-1}	$n_{i,k+1}$
Nitrogen				692.6	0.05569	0.05569	0.0557	1.0000	0.05569
EtAC	0.00984	0.2735	2.155	39.0	0.00314	0.01298	0.0125	0.9619	0.00947
EtOH	0.02615	0.7265	1.075	28.4	0.00228	0.02843	0.0282	0.9924	0.02595

Iteration 3	n_i	x_i	γ_i	p_i	$n_{i,v}$	$n_{i,L+v}$	$n_{i,F}$	Φ^{-1}	$n_{i,k+1}$
Nitrogen				693.0	0.05569	0.05569	0.0557	1.0000	0.05569
EtAC	0.00947	0.2673	2.175	38.5	0.00309	0.01256	0.0125	0.9939	0.00941
EtOH	0.02595	0.7327	1.072	28.5	0.00229	0.02825	0.0282	0.9990	0.02593

Iteration 4	n_i	x_i	γ_i	p_i	$n_{i,v}$	$n_{i,L+v}$	$n_{i,F}$	Φ^{-1}	$n_{i,k+1}$
Nitrogen				693.0	0.05569	0.05569	0.0557	1.0000	0.05569
EtAC	0.00941	0.2663	2.179	38.4	0.00309	0.01250	0.0125	0.9991	0.00940
EtOH	0.02593	0.7337	1.071	28.6	0.00230	0.02822	0.0282	0.9999	0.02592

Iteration 5	n_i	x_i	γ_i	p_i	$n_{i,v}$	$n_{i,L+v}$	$n_{i,F}$	Φ^{-1}	$n_{i,k+1}$
Nitrogen				693.0	0.05569	0.05569	0.0557	1.0000	0.05569
EtAC	0.00940	0.2662	2.179	38.4	0.00309	0.01249	0.0125	0.9999	0.00940
EtOH	0.02592	0.7338	1.071	28.6	0.00230	0.02822	0.0282	1.0000	0.02592

Iteration 6	n_i	x_i	γ_i	p_i	$n_{i,v}$	$n_{i,L+v}$	$n_{i,F}$	Φ^{-1}	$n_{i,k+1}$
Nitrogen				693.0	0.05569	0.05569	0.0557	1.0000	0.05569
EtAC	0.00940	0.2661	2.180	38.4	0.00309	0.01249	0.0125	1.0000	0.00940
EtOH	0.02592	0.7339	1.071	28.6	0.00230	0.02822	0.0282	1.0000	0.02592

Table 4-22. Condenser Material Balance at Completion of Iterations

Iteration 6	Feed	Condensate Out		Vapor Out		$L_i + V_i$	Material Balance
	F_i , lb	$n_{i,L}$ lb-mole	L_i , lb	$n_{i,v}$ lb-mole	V_i , lb		
Nitrogen	1.56	0	0	0.0557	1.56	1.5600	100%
Ethyl Acetate	1.10	0.0094	0.8282	0.0031	0.27	1.1000	100%
Ethanol	1.30	0.0259	1.1942	0.0023	0.11	1.3000	100%

Table 4-23. Exit Vent Stream Analysis Table
(Based on the final results from Table 4-22 and Iteration #6)

Compound	p_i , mm Hg	M. Wt.	Lb-Moles	V_i
Nitrogen	693.0	28.013	0.0557	1.56 lb
Ethyl Acetate	38.4	88.1	0.0031	0.27 lb
Ethanol	28.6	46.07	0.0023	0.11 lb

4.2.4 Vent Condenser with Two Phase Condensate

When two liquid phases are generated, the problem can be solved algebraically because the two liquid phases must be in equilibrium. This situation is examined in illustration 4-9. The problem is more complicated with additional liquid phases. The modified Rachford Rice equation would not be applicable, but either the vapor pressure correction method or the material balance correction method could be used. This more complicated situation is beyond the current scope of this document.

Illustration 4-9: Vent condenser with two phase condensate

A condenser is used at atmospheric pressure (760 mm Hg). The inlet process gas stream contains nitrogen (5.0 lb/hr), water (10.0 lb/hr), and toluene (20.0 lb/hr). The condenser temperature is such that the exit streams are at 20°C.

Using the simplified condensate analysis approach, calculate the emissions (V_i) and the material balance for this condenser.

Data Provided

P_t	21.827 mm Hg	20°C
P_w	17.351 mm Hg	20°C
P_{sys}	760 mm Hg	System pressure
Time	1 hr	Time for event

Inlet Stream:

Compound	Rate (lb/hr)	Molecular Weight
Nitrogen	5.0 lb/hr	28.013
Water	10.0 lb/hr	18.02
Toluene	20.0 lb/hr	92.13

The inlet gas stream at the condenser is analyzed and the rate in lb-mole/hr, mole fraction, and partial pressures are calculated using the standard equations.

$$n_{i,F} = \frac{F_i}{MWt_i} \quad y_i = \frac{n_{i,F}}{\sum n_F} \quad p_i = y_i P_i$$

Table 4-24. Inlet Stream Analysis over 1.0 Hour

Compound	F_i Rate (lb/hr)	Molecular Weight	$n_{i,F}$ (lb-mole)	Mole Fraction	Partial Pressure (mm Hg)
Nitrogen	5.0 lb/hr	28.013	0.1785	0.188	142.72

Water	10.0 lb/hr	18.02	0.5549	0.584	443.69
Toluene	20.0 lb/hr	92.13	0.2171	0.228	173.59
Totals			0.9505	1.000	760.00

Equilibrium Considerations

For a single liquid phase, the following equation can be used to calculate the equilibrium vapor pressure p_i for component i in the liquid.

$$x_i \gamma_i P_i = p_i \quad \text{Eq. 4-55}$$

Where x_i is the liquid mole fraction of component i ,

γ_i is the activity coefficient of component i ,

P_i is the pure component vapor pressure of component i at the mixture temperature, and

For two liquid phases in equilibrium, the vapor pressure p_i of component i is the same for each phase.

$$p_{i,1} = p_{i,2} \quad \text{Eq. 4-56}$$

Where x_i is the liquid mole fraction of component i ,

γ_i is the activity coefficient of component i ,

P_i is the pure component vapor pressure of component i at the mixture temperature.

Substituting the

$$x_{i,1} \gamma_{i,1} P_i = x_{i,2} \gamma_{i,2} P_i \quad \text{Eq. 4-57}$$

$$x_{i,1} \gamma_{i,1} = x_{i,2} \gamma_{i,2} \quad \text{Eq. 4-58}$$

Therefore, if a two phase liquid exists of known composition and the activity coefficient $\gamma_{i,1}$ is known then $\gamma_{i,2}$ may be estimated as shown.

$$\gamma_{i,1} = \frac{x_{i,2} \gamma_{i,2} P_i}{x_{i,1} P_i} = \frac{x_{i,2} \gamma_{i,2}}{x_{i,1}} \quad \text{Eq. 4-59}$$

Activity coefficients for water and toluene in a two liquid phase mixture can be estimated using these relationships between the two liquid phases. At 20°C water and toluene form a two liquid phase mixture with the following composition.

Table 4-25. Liquid Phase Solubility Data for 20°C

	NonAqueous Phase	Aqueous Phase
Toluene	0.9995 (wt/wt)	0.000515 (wt/wt)

Water	0.0005 (wt/wt)	0.999485 (wt/wt)
-------	----------------	------------------

The equilibrium concentrations listed in Table 4-26 can be converted to equivalent mole fractions using Eq. 4-

$$x_i = \frac{wt_i/MWt_i}{wt_i/MWt_i + wt_j/MWt_j} \quad \text{Eq. 4-13}$$

Table 4-26. Equilibrium Mole Fraction Concentrations

	Non-Aqueous Phase molar concentration	Aqueous Phase molar concentration
Toluene	99.745%	0.010%
Water	0.255%	99.990%

Estimating activity coefficients for liquid phase components

The activity coefficients for toluene and water can be estimated for each liquid phase using the relationship in Eq. 4-58. For the aqueous phase it is reasonable to assume that water exhibits an ideal behavior and that the activity coefficient for water is 1.0 since the concentration of water is close to 100%. Similarly, the activity coefficient for toluene in the non-aqueous phase can be assumed to be 1.0. The activity coefficient for toluene in the aqueous phase may then be calculated.

$$\gamma_{i,1} = \frac{x_{i,2}\gamma_{i,2}}{x_{i,1}} \quad \gamma_{i,2} = \frac{x_{i,1}\gamma_{i,1}}{x_{i,2}} \quad \text{Eq. 4-61}$$

Calculate the activity coefficient for toluene in the aqueous phase (phase #1) by applying Eq. 4-61.

$$\gamma_{t,1} = \frac{(0.99745)(1.0)}{(0.0001)} = 9974.5 \quad \text{Eq. 4-62}$$

Calculate the activity coefficient for water in the non-aqueous phase (phase #2) using Eq. 4-61.

$$\gamma_{w,2} = \frac{(0.9999)(1.0)}{(0.00255)} = 392.1 \quad \text{Eq. 4-63}$$

Table 4-27. Estimated Activity Coefficients

	Non-Aqueous Phase	Aqueous Phase
Toluene	1.0	9974.5
Water	392.1	1.0

Evaluating whether condensation will take place in the condenser and if so will one or two liquid phases be formed

For this problem, the combined process stream through the condenser (air leakage, toluene vapors, and water vapors) has been analyzed and is shown in Table 4-24. Now that the activity coefficients for toluene and water have been estimated and are shown in Table 4-27 for a two liquid phase mixture, it is important to evaluate whether condensation will occur in the condenser at all or if so, will one or two liquid phases be formed.

At equilibrium conditions, Eq. 4-55 applies for each liquid phase that might be present. Eq. 4-55 can be modified so that x_i can be calculated from the conditions at equilibrium. The sum of all components in the liquid phase must equal to 1.0 and so Eq. 4-66 can be written.

However, at this stage of the problem, equilibrium compositions have not yet been determined for the problem. Eq. 4-66 can be used in conjunction with the component partial pressures in the inlet stream and the pure component vapor pressures at the condenser temperature to determine if condensation should be considered for a specific liquid phase. If the calculated value for Eq. 4-66 is greater than 1.0, then one can initially assume that condensation will occur for the liquid phase being considered. On the other hand, if the calculated value for Eq. 4-66 is less than 1.0 then one can assume that condensate will not occur for the liquid phase being studied.

$$x_i \gamma_i P_i = p_i \quad \text{Eq. 4-64}$$

$$x_i = \frac{p_i}{\gamma_i P_i} \quad \text{Eq. 4-65}$$

$$\left[\sum_{i=1}^n x_i = \sum_{i=1}^n \frac{p_i}{\gamma_i P_i} = 1.0 \right]_{\text{liquid phase}} \quad \text{Eq. 4-66}$$

The feasibility that condensate will form in the condenser is determined for an aqueous liquid phase and a non-aqueous liquid phase using Eq. 4-66. Results from these calculations are shown in Table 4-28 and Table 4-29.

Table 4-28. Aqueous Phase Condensate Feasibility Analysis

	Inlet Partial Pressure (mm Hg)	Activity Coefficient	Pure Component Vapor Pressure mm Hg@ 20°C	Mole Fraction x_i
Water	443.69	1	17.351	25.57
Toluene	173.59	9974.5	21.827	0.0008
			$\sum_{i=1}^n x_i =$	25.57

The sum of the theoretical liquid phase mole fractions for an aqueous phase condensate is 25.57 and greater than 1.0. Therefore, we can assume that a condensate liquid mixture will form and contain at least an aqueous phase.

Table 4-29. Non-Aqueous Phase Condensate Feasibility Analysis

	Inlet Partial Pressure (mm Hg)	Activity Coefficient	Pure Component Vapor Pressure mm Hg@ 20°C	Calculated Mole Fraction x_i
Water	443.69	392.1	17.351	0.07
Toluene	173.59	1.0	21.827	7.95
			$\sum_{i=1}^n x_i =$	8.02

The sum of the theoretical liquid phase mole fractions for a non-aqueous phase is 8.02 and also greater than 1.0. Therefore, a condensate mixture from this condenser will likely have a non-aqueous phase as well as an aqueous liquid phase.

During the course of iterating to determine the condenser solution, it is possible for the sum of the x_i values might fall below 1.0 for one of the liquid phases, in which case that phase would no longer be considered as feasible. This is because, as iterations are taking place and the separate liquid phases are being formed (by way of the math), it is possible for the residual amount of material in vapor phase to fall below a level that can continue to support the presence of one of the liquid phases.

Solving for a two liquid phase condensate

The condenser is being treated as a single stage device and so equilibrium is assumed to exist between the exit vent gas and the liquid condensate. Equilibrium is also assumed to exist between the two separate liquid phases in the condensate as well. Therefore, the vapor pressure of toluene and water for each liquid phase is identical as shown by Eq. 4-56 and Eq. 4-57. Phase solubility data for toluene and water at 20°C are given in Table 4-25 and Table 4-26 while the activity coefficients are calculated and shown in Table 4-27. As long as there is enough toluene and water in the system to support two separate liquid phases in the condensate then the molar composition of each phase is governed by the phase solubility data. The calculated partial pressure shown in Table 4-30 will be the same regardless how much toluene and water are present in the system as long as there is enough to support two liquid phases in the condensate.

Table 4-30. Composition and Vapor Pressure Analysis of the Two Phase Condensate

Component	Nonaqueous Phase		Aqueous Phase		Pure VP _i	Partial VP _i
	X_i	γ_i	X_i	γ_i	P_i	p_i
Toluene	0.9975	1.0	0.0001	9974.5	21.827	21.772
Water	0.0025	392.1	0.9999	1.0	17.351	17.349

One can calculate the partial pressure of nitrogen in the exit vapor stream by subtracting the partial pressure of toluene and water from the system pressure as shown.

Exit Vapor Analysis

$$p_{N_2} = 760.0 - p_t - p_w \quad \text{Eq. 4-67}$$

$$p_{N_2} = 760.0 - 21.772 - 17.349 = 720.879 \text{ mmHg}$$

$$n_{t,V} = n_{N_2} \frac{p_t}{p_{N_2}} = 0.1785 \frac{21.772}{720.879} = 0.0054 \text{ lb-moles}$$

$$n_{w,V} = n_{N_2} \frac{p_w}{p_{N_2}} = 0.1785 \frac{17.349}{720.879} = 0.0043 \text{ lb-moles}$$

Exit Liquid Analysis

The moles of condensate can be determined by subtracting the moles of toluene and water that exit in the vapor phase from the moles of toluene and water that exit in the two liquid phases.

$$n_{t,1\&2} = n_{t,F} - n_{t,V} = 0.2171 - 0.0054 = 0.2117 \text{ lb-moles} \quad \text{Eq. 4-68}$$

$$n_{w,1\&2} = n_{w,F} - n_{w,V} = 0.5549 - 0.0043 = 0.5506 \text{ lb-moles} \quad \text{Eq. 4-69}$$

$n_{t,1\&2}$ and $n_{w,1\&2}$ are the moles of toluene and water that are contained in the combined two liquid phases. Equations can be written that relate the composition of the aqueous phase and the nonaqueous phase to the total moles of toluene and water as liquid.

$$x_{t,1}L_1 + x_{t,2}L_2 = n_{t,1\&2} \quad \text{Eq. 4-70}$$

$$x_{w,1}L_1 + x_{w,2}L_2 = n_{w,1\&2} \quad \text{Eq. 4-71}$$

L_1 are the moles of nonaqueous phase and L_2 are the moles of aqueous phase in the condensate. The objective is to now solve Eq. 4-70 and Eq. 4-71 for L_1 and L_2 and then calculate the moles of toluene and water that are contained in each phase based on the known solubility data. This can be accomplished through algebraic manipulation of Eq. 4-70 and Eq. 4-71 as shown:

$$x_{w,2}x_{t,1}L_1 + x_{w,2}x_{t,2}L_2 = x_{w,2}n_{t,1\&2} \quad \text{Eq. 4-72}$$

$$x_{t,2}x_{w,1}L_1 + x_{t,2}x_{w,2}L_2 = x_{t,2}n_{w,1\&2} \quad \text{Eq. 4-73}$$

$$x_{w,2}x_{t,1}L_1 - x_{t,2}x_{w,1}L_1 = x_{w,2}n_{t,1\&2} - x_{t,2}n_{w,1\&2} \quad \text{Eq. 4-74}$$

$$L_1 = \frac{x_{w,2}n_{t,1\&2} - x_{t,2}n_{w,1\&2}}{x_{w,2}x_{t,1} - x_{t,2}x_{w,1}} \quad \text{Eq. 4-75}$$

L_1 and L_2 can finally be calculated using Eq. 4-76 and Eq. 4-77. Molar quantities of toluene and water can then be calculated once L_1 and L_2 are known.

$$L_1 = \frac{0.9999 * 0.2117 - 0.0001 * 0.5506}{0.9999 * 0.9975 - 0.0001 * 0.0025} = \frac{0.2116}{0.9998} = 0.2117 \text{ lb-moles} \quad \text{Eq. 4-76}$$

$$L_2 = L_{1\&2} - L_1 = 0.7623 - 0.2067 = 0.5506 \text{ lb-moles} \quad \text{Eq. 4-77}$$

Nonaqueous Phase

$$n_{t,1} = x_{t,1} * L_1 = 0.9975 * 0.2117 = 0.2111 \text{ lb-moles}$$

$$n_{w,1} = x_{w,1} * L_1 = 0.0025 * 0.2117 = 5.292 \times 10^{-4} \text{ lb-moles}$$

Aqueous Phase

$$n_{t,2} = x_{t,2} * L_2 = 0.0001 * 0.5506 = 5.506 \times 10^{-5} \text{ lb-moles}$$

$$n_{w,2} = x_{w,2} * L_2 = 0.9999 * 0.5506 = 0.5506 \text{ lb-moles}$$

Table 4-31. Exit Liquid Stream Analysis

	Nonaqueous		Aqueous	
	X _i	n ₁ (lb-moles)	X _i	n ₂ (lb-moles)
Toluene	0.9975	0.2111	0.0001	5.5506 x 10 ⁻⁵
Water	0.0025	5.292 x 10 ⁻⁴	0.9999	0.5506
Totals		0.2117		0.5507

Table 4-32. Condenser Material Balance at Completion of Iterations

	Nonaqueous		Aqueous		Vapor		Total In	Total Out	Material
	n _{i,1}	lb	n _{i,2}	lb	n _{i,v}	lb	Lb	Lb	Balance
Nitrogen		0.000		0.000	0.1785	5.00	5.000	5.00	100.0%
Toluene	0.2111	19.45	5.5506x10 ⁻⁵	5.11x10 ⁻³	0.0054	0.498	20.000	19.95	99.8%
Water	5.292x10 ⁻⁴	9.54x10 ⁻³	0.5506	9.92	0.0043	0.077	10.000	10.01	100.1%
	0.2117		0.5507						

Table 4-33. Exit Vent Stream Analysis Table
(Based on the final results from Table 4-32)

Compound	mm Hg	MWt	Lb-Moles	Lb
Nitrogen	720.9	28.013	0.1785	5.000
Toluene	21.8	92.13	0.0054	0.498
Water	17.4	18.02	0.0043	0.077

4.2.5 Liquid-Ring Vacuum Pump

In a liquid-ring vacuum pump the gas stream mixes with the fluid (typically water) used to operate the pump. As a result some of the soluble compounds in the gas stream will be absorbed into the fluid. The procedures for estimating the amount of each soluble compound that is absorbed and emitted is the same as for the condensers described in previous sections in this document. Just as in the condenser examples, the composition of the exit liquid from the liquid-ring vacuum pump is unknown and must be determined by trial and error. The modified Rachford-Rice equation, the partial pressure correction method, or the

material balance correction method could be used to solve the problem. Illustration 4-10 uses the partial pressure correction method.

Illustration 4-10: Liquid-Ring Vacuum Pump with multi-component process stream.

A liquid-ring vacuum pump is being used to maintain a distillation operation at 100 mm Hg absolute pressure. The inlet process vapor stream at the vacuum pump consists of air (0.95 lb/hr), methanol (8.56 lb/hr), ethanol (6.35 lb/hr), and isopropyl alcohol (4.25 lb/hr) vapors. The exit liquid and vapor from the vacuum pump discharges to atmospheric conditions at 25°C.

External air is being bleed into the vacuum pump at a rate of 2.60 lb/hr for control purposes to help maintain the 100 mm Hg absolute pressure. The liquid-ring vacuum pump is operated using water with a fresh water make-up rate of 480.0 lb/hr. Spent water from the vacuum pump and travels to waste treatment at 25°C.

What would the emissions and the material balance for the vacuum pump be over a one hour period under these operating conditions? Assume that liquid phase in the vacuum pump behaves as an ideal mixture.

An analysis of the problem requires that the inlet process stream, the air bleed, and the make-up water must all be taken into account. The three streams enter the vacuum pump, become mixed, and then separate out as they exit the unit. The resulting gas and liquid streams that exit the vacuum pump are considered to be in equilibrium. Table 4-34 provides a component break down of the combined process stream present in the vacuum pump.

Table 4-34. Analysis of the Inlet Stream to the Liquid-Ring Vacuum Pump

	Source	F _i lb/hr	MWt	n _{i,F} lb-m/hr	z _i
Noncondensable					
Air	Process	0.95			
Air	External Bleed	2.60			
Air (total)		3.55	28.97	0.1225	0.0045
Condensable					
Methanol	Process	8.56	32.04	0.2672	0.0098
Ethanol	Process	6.35	46.07	0.1378	0.0051
Isopropyl Alcohol	Process	4.25	60.096	0.0707	0.0026
Water	External Make-Up	480.00	18.02	26.6371	0.9780

Solution

In preparing to solve this problem using the Partial Pressure Correction method, we must first arrive at an initial guess for the composition of the liquid that will discharge from the vacuum pump. Upon inspection of Table 4-34, it becomes apparent that the bulk of the inlet stream (97.8%) consists of water (480 lb/hr) and that the remainder of the components (including air) makes up only 2.2%. Additionally, the water exits the vacuum pump at 25°C and at atmospheric pressure which means that approximately 97.8% of the total discharge from the vacuum pump will be in the form of liquid. Additionally, the vacuum pump discharges at 760 mm Hg pressure which is significantly higher than the vapor pressure of water (23.6 mm Hg). Therefore, one would not be very far away from the discharge liquid composition if 100% of the condensable components were chosen as an initial guess.

Table 4-35. Analysis of the Inlet Stream and Initial Guess of the Exit Liquid Composition

Component	P_i @ 25°C mm Hg	Feed from Table 4-34 $n_{i,F}$ lb-moles/hr	Initial Guess $n_{i,L}$ lb-moles/hr
Noncondensable			
Air (total)	N/A	0.1225	N/A
Condensable			
Methanol	122.278	0.2672	0.2672
Ethanol	57.6	0.1378	0.1378
Isopropyl Alcohol	45.152	0.0707	0.0707
Water	23.575	26.6371	26.6371

Newton's method can readily accommodate this initial guess since it would result in $(p_{i,L} - p_{i,V}) = p_{i,L}$ since $p_{i,V}$ would be initially set to 0. Moles of each component would immediately begin being moved from the liquid phase to the vapor phase upon the first iteration. Only three iterations were required to calculate a solution to the desired tolerance as shown:

Iteration 1

Components	$n_{i,L,k}$	x_i	$p_{i,L}$	$n_{i,V}$	y_i	$p_{i,V}$	$p_{i,L} - p_{i,V}$	$\Delta n_{i,L}$	$n_{i,L,k+1}$
Air			735.223	0.1225	1.0000	760.000			
Methanol	0.2672	0.00985	1.205	0.0000	0.00E+00	0.000	1.20E+00	1.94E-04	0.2670
Ethanol	0.1378	0.00508	0.293	0.0000	0.00E+00	0.000	2.93E-01	4.72E-05	0.1378
IPA	0.0707	0.00261	0.118	0.0000	0.00E+00	0.000	1.18E-01	1.90E-05	0.0707
Water	26.6371	0.98245	23.161	0.0000	0.00E+00	0.000	2.32E+01	3.69E-03	26.6334

Iteration 2

Components	$n_{i,L,k}$	x_i	$p_{i,L}$	$n_{i,V}$	y_i	$p_{i,V}$	$p_{i,L} - p_{i,V}$	$\Delta n_{i,L}$	$n_{i,L,k+1}$
Air			735.224	0.1225	0.9688	736.263			
methanol	0.2670	0.00985	1.204	0.0002	1.53E-03	1.166	3.78E-02	6.29E-06	0.2670
ethanol	0.1378	0.00508	0.293	0.0000	3.73E-04	0.284	9.18E-03	1.53E-06	0.1378
IPA	0.0707	0.00261	0.118	0.0000	1.50E-04	0.114	3.69E-03	6.15E-07	0.0707
water	26.6334	0.98246	23.162	0.0037	2.92E-02	22.173	9.89E-01	1.68E-04	26.6332

Iteration 3

Components	$n_{i,L,k}$	x_i	$p_{i,L}$	$n_{i,V}$	y_i	$p_{i,V}$	$p_{i,L} - p_{i,V}$	$\Delta n_{i,L}$	$n_{i,L,k+1}$
air			735.224	0.1225	0.9674	735.240			
methanol	0.2670	0.00985	1.204	0.0002	1.58E-03	1.203	1.62E-03	2.71E-07	0.2670
ethanol	0.1378	0.00508	0.293	0.0000	3.85E-04	0.292	4.05E-04	6.76E-08	0.1378
IPA	0.0707	0.00261	0.118	0.0000	1.55E-04	0.118	1.64E-04	2.73E-08	0.0707
water	26.6332	0.98246	23.162	0.0039	3.05E-02	23.148	1.38E-02	2.35E-06	26.6332

The material balance and composition equilibrium can be evaluated for iteration 3 to ensure that the convergence has been adequately met. The material balance can be checked for each component by dividing the sum of the moles in the liquid and the vapor by the moles in the inlet stream for each component. A 100% material balance is an integral part of the Partial Pressure Correction method since the moles of each component in the vapor phase are calculated by subtracting the moles that have been assigned to the liquid phase from the moles that are in the feed. This is reflected in Table 4-36 under material accountability column.

Table 4-36. Material Balance Accountability

Component	ni,F	ni,L	ni,V	ni,L+ni,V	Accountability
Air	0.1225	0.0000	0.1225	0.1225	100.00%
Methanol	0.2672	0.2670	2.01E-04	0.2672	100.00%
Ethanol	0.1378	0.1378	4.88E-05	0.1378	100.00%
IPA	0.0707	0.0707	1.96E-05	0.0707	100.00%
Water	26.6371	26.6332	3.86E-03	26.6371	100.00%
	27.2353	27.1087	0.1267	27.2353	100.00%

The Partial Pressure Correction method works to minimize the difference between the calculated partial pressure for each component based on the liquid phase composition with the calculated partial pressure of each component based on the vapor phase makeup. This convergence technique was fairly efficient for this vacuum pump problem since the two partial pressures agreed within 0.00213% after only three iterations.

Table 4-37. Partial Pressure Equilibrium Accountability

Component	piL	piV	%error
Air	735.2238	735.2240	-3.43E-05
Methanol	1.2042	1.2042	1.94E-03
Ethanol	0.2928	0.2928	2.10E-03
IPA	0.1178	0.1178	2.13E-03
Water	23.1615	23.1613	9.50E-04

Additional considerations regarding numerical convergence techniques

The Partial Pressure Correction method proved to be a very efficient approach for this problem. When this same problem is solved using the Modified Rachford-Rice model then as many as 100 iterations are required to achieve the same degree of convergence. A main reason that the Modified Rachford-Rice method was less efficient was due to the large amount of water that was in the system. Since the process stream consists of 97.8% water then the remaining components (methanol, ethanol, and isopropyl alcohol) became very small numbers to work with. The Modified Rachford-Rice approach adjusts V/F until the complete based equation is solved. However, since V/F includes the methanol, ethanol, and isopropyl alcohol along with the large amount of water then V/F needs to be evaluated to a much greater precision to accommodate for the loss in accuracy of the convergence.

The Partial Pressure Correction method focuses on the convergence of each individual component in a concurrent fashion. So regardless whether the component occupied as much as 97.8% (as in the case of water) of the process or as little as 0.0026% (as in the case of the isopropyl alcohol) convergence process was carried out to the same degree of precision for each component.

4.2.6 Vacuum Steam Jets

In a vacuum steam jet steam is mixed with the process gas stream and then condensed. As for the condensers described in earlier sections in this chapter, the composition of the condensate may be unknown, which means the composition of the exit gas stream must be determined through trial and error. The modified Rachford-Rice equation, partial pressure correction method, or material balance correction method could be used to solve this problem. The problem in illustration 4-11 is solved using the material balance correction method.

Illustration 4-11: Vacuum steam jet – material balance correction method.

A vacuum steam jet is used to maintain 100 mm Hg for a process. The inlet process gas stream contains air (1.61 lb/hr) and toluene vapors (1.53 lb/hr). Steam is feed to the vacuum jet at a rate of 120 lb/hr and is condensed in the unit as part of the normal operation. An external air bleed (1.0 lb/hr) is used to help maintain the controlled 100 mm Hg absolute pressure at the process.

The liquid condensate and the exit vapors discharge to atmospheric pressure at 55°C.

Estimate the discharge vent emissions from the vacuum steam jet.

Data Provided:

P_T	113.8 mm Hg	55°C
P_W	118.0 mm Hg	55°C
P_{sys}	760 mm Hg	discharge pressure
Time	1 hr	Time for event

Solubility data at 55°C:

$X_{T,ph-1}$	0.000168 mole fraction	aqueous phase
$X_{W,ph-2}$	0.0063 mole fraction	non-aqueous phase

Inlet process stream to the vacuum steam jet:

Compound	Rate (lb/hr)	Molecular Weight
Air	1.61 lb/hr	28.97
Toluene	1.53 lb/hr	92.13

Steam and external air bleed rate to the vacuum steam jet:

Compound	Rate (lb/hr)	Molecular Weight
Water	120.0 lb/hr	18.02
Air	1.0 lb/hr	28.97

The inlet gas stream at the condenser is analyzed as follows using standard equations and relationships:

$$n_{i,F} = \frac{F_i}{MW t_i} \quad y_i = \frac{n_{i,F}}{\sum n_F} \quad p_i = y_i P_i$$

Table 4-38. Steam Jet Process Stream Analysis for 1.0 Hour of Operation

Compound	F _i lb/hr	Molecular Weight	n _{i,F} lb-mole	y _i mole Fraction	p _i , mm Hg
Air from process	1.61				
Air from bleed	1.00				
Total Air	2.61	28.970	0.090	0.013	10.12
Water	120.00	18.020	6.659	0.984	748.02
Toluene	1.53	92.13	0.017	0.001	1.86
Totals			6.766	1.000	760.00

Equilibrium Considerations and Estimating Activity Coefficients**Table 4-39. Equilibrium Mole Fraction Concentrations**

	Aqueous Phase mole fraction	Non-Aqueous Phase mole fraction
Toluene	0.000168	0.993697
Water	0.999832	0.006303

The activity coefficients for toluene and water can be estimated for each liquid phase using Eq. 4-78. For the aqueous phase it is reasonable to assume that water exhibits ideal behavior and that the activity coefficient is 1.0 since the concentration of water is close to 100%. Similarly, one can assume that the activity coefficient for toluene in a non-aqueous phase would be approximately 1.0. The activity coefficient for toluene in the aqueous phase and the activity coefficient for water in a non-aqueous phase may then be calculated from equations that were previously developed.

$$\gamma_{i,1} = \frac{x_{i,2}\gamma_{i,2}}{x_{i,1}} \quad \gamma_{i,2} = \frac{x_{i,1}\gamma_{i,1}}{x_{i,2}} \quad \text{Eq. 4-78}$$

Where the activity coefficient for toluene in the aqueous phase (phase #1) is calculated as follows:

$$\gamma_{t,1} = \frac{(0.993697)(1.0)}{(0.000168)} = 5903$$

Similarly, the activity coefficient for water in the non-aqueous phase (phase #2) is calculated.

$$\gamma_{w,2} = \frac{(0.999832)(1.0)}{(0.006303)} = 159 \quad \text{Eq. 4-79}$$

Table 4-40. Estimated Activity Coefficients

	Aqueous Phase	Non-Aqueous Phase
Toluene	5903.0	1.0
Water	1.0	159.0

Testing for condensation at steam jet discharge conditions

For this problem, the combined process stream through the vacuum jet (air leakage, toluene vapors, and water vapors) has been analyzed and is shown in Table 4-38. Now that the activity coefficients for toluene and water have been estimated and are shown in Table 4-40 for a two liquid phase mixture, it is important to test to know if the process discharge stream will contain one or more liquid phases.

Results from this analysis are shown in Table 4-41 and Table 4-42.

Table 4-41. Aqueous Phase Condensate Feasibility Analysis

	Inlet Partial Pressure (mm Hg)	Activity Coefficient	Pure Component Vapor Pressure mm Hg@ 20°C	Mole Fraction x_i
Water	748.02	1	118.0	6.34
Toluene	1.86	5903	113.8	2.8E-06
				$\sum_{i=1}^n x_i = 6.34$

The sum of the theoretical liquid phase mole fractions for an aqueous phase condensate is 6.34. Therefore, we can assume that the discharge process stream from the vacuum jet will at least contain an aqueous phase which will consist mostly of water.

Table 4-42. Non-Aqueous Phase Condensate Feasibility Analysis

	Inlet Partial Pressure (mm Hg)	Activity Coefficient	Pure Component Vapor Pressure mm Hg@ 20°C	Calculated Mole Fraction x_i
Water	748.02	1.0	118.0	0.04
Toluene	1.86	159.0	113.8	0.02
				$\sum_{i=1}^n x_i = 0.06$

The sum of the theoretical liquid phase mole fractions for a non-aqueous phase is 0.06. Therefore, we can conclude that the discharge process stream will not contain a non-aqueous phase since the sum of the mole fractions is less than 1.0.

Solving for a single phase condensate using the Material Balance Correction Method

$$\frac{n_{i,L} + n_{i,V}}{n_{i,F}} = \phi_i \quad \text{Eq. 4-80}$$

$$n_{i,L,k+1} = \frac{n_{i,L,k}}{\phi_{i,k}} \quad \text{Eq. 4-81}$$

For each condensable component in the inlet stream, the following steps are followed until the error of estimate for each component has fallen within an acceptable tolerance.

Iterating to solve the condenser problem

The iteration results are presented in Table 4-43 for the solution. The equilibrium mole fractions in the aqueous solution at 55°C (see Table 4-39) are used to determine the number of moles of condensables (i.e., water and toluene) in the condensate for the first iteration. The partial pressures of toluene and water in the outlet vapor, assuming equilibrium with the condensate are estimated using Eq. 4-6; the partial pressure of air is determined as the difference between the system pressure and the sum of the partial pressures for toluene and water. Moles of toluene and water in the outlet vapor are estimated using Eq. 4-5. The value of Φ , the ratio of the estimated sum of moles of a condensable in condensate and outlet vapor to the known feed moles, is estimated for both condensable compounds using Eq. 4-80. New estimates of the number of moles of each condensable in the condensate are calculated using Eq. 4-81. These estimates are used as the starting values for the second iteration. The process repeats until convergence is obtained. The resulting composition of the condensate and the outlet gas stream are shown in Tables 4-44 and 4-45.

Table 4-43. Iterative Solution to Vacuum Steam Jet Problem with Aqueous Phase Condensate

Iteration 1	$n_{i,L,k}$	x_i	p_i	$n_{i,v}$	$n_{i,L+v}$	$n_{i,F}$	$\Phi_{i,k}$	$n_{i,L,,k+1}$
Air			528.9	0.09009	0.09009	0.0901	1.0000	0.09009
Water	6.65927	0.9998	118.0	0.02010	6.67936	6.6593	0.9970	6.63923
Toluene	1.119E-03	1.68E-04	113.1	0.01926	0.02038	0.0166	0.8147	0.00091

Iteration 2	$n_{i,L,k}$	x_i	p_i	$n_{i,v}$	$n_{i,L+v}$	$n_{i,F}$	$\Phi_{i,k}$	$n_{i,L,,k+1}$
Air			549.6	0.09009	0.09009	0.0901	1.0000	0.09009
Water	6.63923	0.9999	118.0	0.01934	6.65857	6.6593	1.0001	6.63993
Toluene	9.116E-04	1.37E-04	92.4	0.01515	0.01606	0.0166	1.0339	0.00094

Iteration 3	$n_{i,L,k}$	x_i	p_i	$n_{i,v}$	$n_{i,L+v}$	$n_{i,F}$	$\Phi_{i,k}$	$n_{i,L,,k+1}$
Air			546.5	0.09009	0.09009	0.0901	1.0000	0.09009
Water	6.63993	0.9999	118.0	0.01945	6.65938	6.6593	1.0000	6.63982
Toluene	9.425E-04	1.42E-04	95.5	0.01575	0.01669	0.0166	0.9947	0.00094

Iteration 4	$n_{i,L,k}$	x_i	p_i	$n_{i,v}$	$n_{i,L+v}$	$n_{i,F}$	$\Phi_{i,k}$	$n_{i,L,,k+1}$
Air			547.0	0.09009	0.09009	0.0901	1.0000	0.09009
Water	6.63982	0.9999	118.0	0.01943	6.65925	6.6593	1.0000	6.63983
Toluene	9.375E-04	1.41E-04	95.0	0.01565	0.01659	0.0166	1.0008	0.00094

Iteration 5	$n_{i,L,k}$	x_i	p_i	$n_{i,v}$	$n_{i,L+v}$	$n_{i,F}$	$\Phi_{i,k}$	$n_{i,L,,k+1}$
Air			546.9	0.09009	0.09009	0.0901	1.0000	0.09009
Water	6.63983	0.9999	118.0	0.01944	6.65927	6.6593	1.0000	6.63983
Toluene	9.383E-04	1.41E-04	95.1	0.01567	0.01661	0.0166	0.9999	0.00094

Iteration 6	$n_{i,L,k}$	x_i	p_i	$n_{i,v}$	$n_{i,L+v}$	$n_{i,F}$	$\Phi_{i,k}$	$n_{i,L,k+1}$
Air			546.9	0.09009	0.09009	0.0901	1.0000	0.09009
Water	6.63983	0.9999	118.0	0.01944	6.65927	6.6593	1.0000	6.63983
Toluene	9.382E-04	1.41E-04	95.1	0.01566	0.01660	0.0166	1.0000	0.00094

Table 4-44. Condenser Material Balance at Completion of Iterations

Iteration 6	Total In (lb)	$n_{i,1}$	(lb)	$n_{i,v}$	(lb)	Total Out (lb)	Material Balance
Air	2.61		0.00	0.09009	2.61	2.61	100%
Water	120	6.63983	119.65	0.01944	0.35	120.00	100%
Toluene	1.53	9.382E-04	0.09	0.01566	1.44	1.53	100%

Table 4-45. Exit Vent Stream Analysis Table
(Based on the final results from Table 4-44)

Compound	mm Hg	MWt	Lb-Moles	Lb
Air	546.9	28.013	0.09009	2.61
Water	118.0	18.02	0.01944	0.35
Toluene	95.1	92.13	0.01566	1.44

5.0 Basic Process Operations

5.1 Emission Calculations from Solvent Reclamation Systems

After being collected from manufacturing processes, waste solvents are frequently purified and reused in the factory. Distillation is one of the most common means of purifying solvents for reuse. Many forms of distillation are used including simple batch, continuous, or steam distillation.

For emissions modeling, a typical distillation process involves several separate emission modeling steps:

1. The initial filling step when waste solvent is charged to the empty distillation vessel.
2. A heating step when the waste solvent is raised to the solvent boiling point temperature.
3. The recovery phase when purified distillate is collected in the receiving vessel.
4. At the completion of the distillation process any remaining waste solvent in the still is normally cooled. The emissions from cooling are assumed to be zero unless a nitrogen sweep that would overcome gas contraction is being applied.
5. A final drumming step when the recovered solvent is transferred to a solvent holding area or to drums.

Illustration 5-1: Estimating emissions from a batch distillation operation.

One hundred gallons of waste toluene are to be charged to a batch still for distillation recovery. The toluene to be charged is at 18°C and contains 1.5% (mole/mole) dissolved non-volatile waste solids. A boiling point check shows that the waste toluene has a normal boiling point of 111.2°C. The still vessel has a gas space volume of 220 gallons when empty. An overhead heat exchanger is used to condense the pure toluene distillate at 20°C. What are the vent emissions from this event?

5.1.1 Emissions from Charging the Distillation Vessel with Cold Solvent for Recovery

The standard charging model is used to calculate the vent emissions that occur from charging the cold waste solvent to the distillation vessel. Basic values that will be used in the calculation are first calculated.

Determine T(°K):
$$T(^{\circ}\text{K}) = 18.0^{\circ}\text{C} + 273.15 = 291.25^{\circ}\text{K}$$

Antoine Equation:
$$P_{\text{toluene}} = \exp\left(16.0137 - \frac{3096.52}{291.15 - 53.67}\right) = \exp(2.975) = 19.582 \text{ mmHg}$$

Raoult's Law:
$$p_{\text{toluene}} = 0.985 P_{\text{toluene}} = (0.985)(19.582 \text{ mm Hg}) = 19.288 \text{ mm Hg.}$$

Displacement Vol.
$$V \text{ (ft}^3\text{)} = 100 \text{ gallons} * 0.13368 \text{ (ft}^3\text{/gal)} = 13.368 \text{ ft}^3$$

Ideal Gas Constant
$$R = 998.9 \text{ mmHg} \cdot \text{ft}^3 / \text{lb-mole} \cdot ^{\circ}\text{K}$$

Moles of toluene emitted per batch:
$$n_i = \frac{19.288 \cdot 13.368}{998.9 \cdot 291.15} = 0.000887 \text{ lb-moles}$$

Weight of toluene emitted per batch:
$$\text{wt}_i = (0.000887 \text{ lb-moles})(92.13 \text{ lb/lb-mole}) = 0.082 \text{ lbs}$$

5.1.2 Heating the Solvent for Distillation

Since the distillation system contains a process condenser operating at 20°C then we can assume that the exit vent gas caused by heating will leave the equipment system saturated with toluene vapors at the 20°C temperature. It should be noted that during the initial heating process between 18°C and 20°C that the toluene content of the condenser exit gas will be less than the 20°C saturation level. However, this error is considered to be insignificant when compared to the total emissions that occur while heating to the final 111.2°C boiling point temperature prior to distillation.

T_i	=	18°C	=	291.15°K	(Initial temperature)
P_T	=	1.0 atm	=	760 mm Hg	(Total system pressure)
V_{gas}	=	120 gallons	=	16.04 ft ³	(Gas space volume)
R	=	998.9 (mmHg-ft ³)/(lb-mole-°K)			(Universal gas constant)
$P_{\text{toluene, 18°C}}$	=	19.906 mm Hg.			(Antoine Equation)

The partial pressure of nitrogen at 18°C is the difference between the total system pressure and the partial pressure of toluene: $p_{n_2,1} = 760 - p_{\text{toluene},1} = 760 - 19.6 = 740.4 \text{ mmHg}$

Gas Law: $n = \frac{PV}{RT}$, also $n_i = \frac{p_i V}{RT}$ for a single component, i , in the gas space.

Calculate the total amount of nitrogen that is displaced from the still during the heating activity using the ideal gas law at the initial conditions. When the waste toluene temperature reaches the boiling point, it is assumed that all of the nitrogen has been expelled and that the head space in the distillation vessel contains only saturated toluene vapors. Therefore the ideal gas law is used to calculate the moles of nitrogen that is displaced.

Nitrogen discharged from heating: $n_{N_2} = \frac{p_{n_2} V}{RT} = \frac{740.4 * 16.04}{998.9 * 291.15} = 0.041 \text{ lb-moles}$

The condenser has an outlet vent temperature of 20°C. It is assumed that the outlet vent gas is saturated with toluene vapors. Therefore the quantity of toluene that is finally emitted from the process system is calculated by multiplying the moles of nitrogen by the ratio of the toluene and nitrogen partial pressures.

Partial pressure of toluene at 20°C (Antoine Equation): 21.8 mm Hg

Partial pressure of nitrogen at 20°C by difference: (760 - 21.8) = 738.2 mm Hg.

Final toluene emission: $n_{\text{toluene}} = \left(\frac{21.8 \text{ mmHg}}{738.2 \text{ mmHg}} \right) 0.041 = 0.00121 \text{ lb - moles}$

Final toluene emission:

$wt_{\text{toluene}} = (0.00121 \text{ lb - moles})(92.13 \text{ lb / lb - mole}) = 0.0012 \text{ lbs}$

5.1.3 Receiving the Solvent from Distillation

If the initial waste toluene to be distilled contains 1.5% non-volatile impurities and the composition of the final still bottoms is estimated to be 50% toluene and 50% non-volatile impurities, then the expected volume of

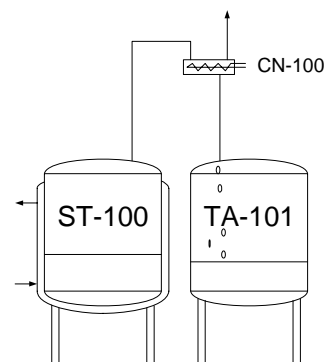

toluene to be recovered will be 97 gallons. The emissions that are associated with the actual distillation operation are calculated using the filling or charging model for TA-101. It is estimated that the distillate toluene enters TA-101 from the condenser at 20°C based on earlier discussions.

Vapor pressure of toluene at 20°C: 21.85 mm Hg.

Displacement volume: 97 gallons * 0.133680555 (gal/ft³) = 12.967 ft³

Toluene emitted per batch: $n_i = \frac{P_i V}{RT} = \frac{21.85 * 12.967}{998.9 * 291.15} = 0.001048$ lb-moles

Toluene emitted per batch: $wt_{toluene} = (0.001048 \text{ lb-moles})(92.13 \text{ lb/lb-mole}) = 0.097 \text{ lbs}$

5.1.4 Drumming the Purified Toluene

Once the 97 gallons of toluene have been purified and collected in TA-101, the batch will be drummed in 50 gallon drums. Unless spot ventilation is provided for the drums then the emission losses that occur during drumming would be considered to be fugitive emissions. Emissions for this operation are calculated as a simple filling operation. As the 97 gallons of toluene are transferred from the receiver into drums then 97 gallons of saturated solvent vapor are displaced from the drums. The emissions are calculated using the ideal gas law as before.

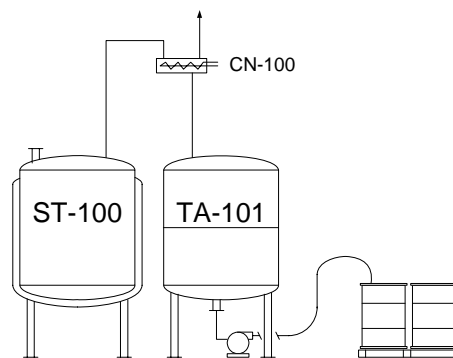

Toluene emitted per batch:

$n_i = \frac{P_i V}{RT} = \frac{21.85 * 12.967}{998.9 * 291.15} = 0.001048$ lb-moles

Toluene emitted per batch: $wt_{toluene} = (0.001048 \text{ lb-moles})(92.13 \text{ lb/lb-mole}) = 0.097 \text{ lbs}$

5.1.5 Solvent Emissions from the Overall Toluene Recovery Process

Solvent emissions from the overall toluene recovery process are estimated by adding the emissions from each of the individual steps.

Activity Description	Amount
Initial charging of 100 gallons of waste toluene solvent	0.0820 lbs
Heating the batch for distillation	0.0012 lbs
Receiving toluene in receiver TA-101	0.0970 lbs
Drumming 97 gallons of recovered toluene	0.0970 lbs
Total Emissions from process	0.2772 lbs

5.2 Filtration Operations

Filtration is an operation that is commonly used when it is desired to separate the solids portion of a process slurry from the liquid portion. Most filtrations involve a slurry feed vessel, a filter, and a filtrate receiving vessel. In some cases the slurry is passed through the filter by pressurizing the feed tank while in other operations the slurry may be pumped. Different types of filters may be used depending upon the processing requirements. For example, the filter may be a bag filter, filter press, leaf filter, centrifuge, or another design.

Examples of batch filtration might include processing when crystalline product that has formed during the process must be isolated from the batch slurry. Other filtration operations are performed when the product is dissolved in the primary processing solvent and the solids are either waste compounds or materials that have added to help purify the dissolved product such as diatomaceous earth or activated carbon.

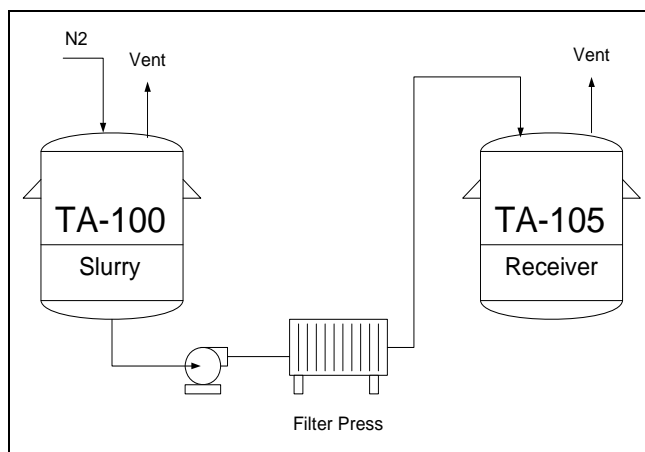

Figure 5-1. Example filtration equipment arrangement.

Batch filtration consists of at least three separate modeling activities including sending the process slurry to the filter initially with process mother liquors being directed into the receiver. The charging or filling model is used to calculate the process vent emissions that occur during this processing step. Since the filter is connected directly to the filtrate receiving vessel then all emissions exit through the receiver process vent. In this case the emissions from the operation are based on the total volume of slurry being processed forward.

A fresh solvent (normally the same solvent that is contained in the process) is passed through the filter cake to the filtrate receiver. The emissions from this operation may also be calculated using a filling model for the filtrate receiver based on the volume of solvent that is used during the wash.

Air or nitrogen gas is usually passed through the filter to displace the residual liquid from the solids filter cake. Displaced liquid from the filter cake is sent to the filtrate receiver. Emissions that occur from this operation may be calculated using the standard filling model that also includes a gas sweep for the filtrate receiver. An exit gas saturation level of 100% is used based on the process filtrate composition.

5.3 Centrifuge Operations

Centrifugation is an operation that is commonly used when it is desired to separate the solids portion of a process slurry from the liquid portion. Most centrifuge operations contain a slurry feed vessel, a centrifuge, and a filtrate receiving vessel. In most cases the slurry is passed to the centrifuge by way of a centrifugal pump. Centrifuge operations normally include a feed step (when slurry is feed to the centrifuge so that the internal basket can be loaded), a spin step (when filtrate is permitted to exit the centrifuge cake), a washing step (when water or process solvent is feed to the centrifuge), a final spin step (when the wash liquor is allowed to separate from the centrifuge cake), followed by a plowing step (when the solid cake is removed from the centrifuge).

Processing when centrifugation might be used would be for situations when crystallized material that has formed during the process must be isolated from the batch. Several centrifuge loads must usually be processed from a single batch of slurry material depending upon the batch size.

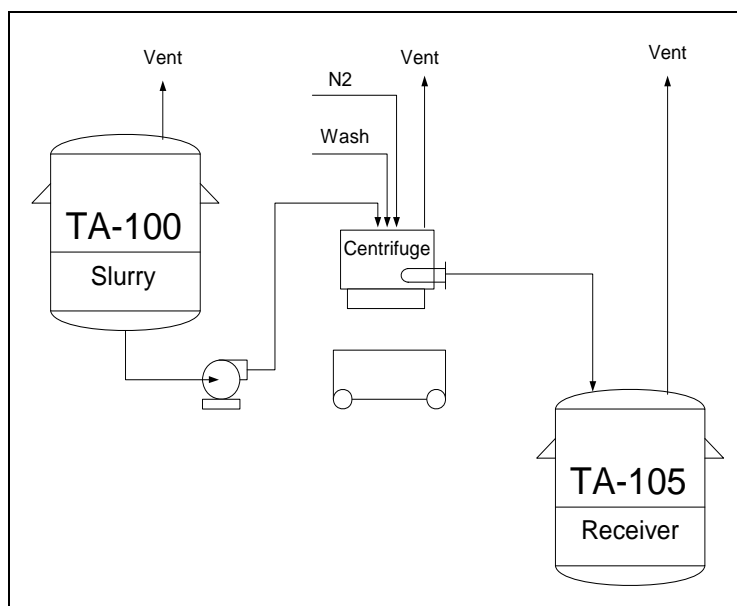

Figure 5-2. Typical centrifuge equipment arrangement.

Centrifugation consists of at least three separate modeling activities.

Feed Step. The initial feed step is when the centrifuge is being loaded with process slurry from the feed vessel and filtrate is being directed to the filtrate receiver from the centrifuge. The charging or filling with gas sweep model is used to calculate the process vent emissions that occur from the centrifuge as well as from the filtrate receiver.

The volumetric capacity of the centrifuge basket is used as the filling volume for the centrifuge and any additional ventilation rate (as established through plant data) is used for the gas sweep portion of the centrifuge emission calculation. If the centrifuge is tightly connected to other ancillary equipment such as an enclosed bottom hopper then the gas sweep rate may be negligible.

Similarly, the volume of filtrate that enters the filtrate receiver from the centrifuge in addition to any gas sweep that is present are the basis for the emission calculation for this vessel.

Wash step. Fresh solvent (normally the same solvent as is contained in the process) is passed through the centrifuge cake to the filtrate receiver. During this phase of the operation the centrifuge basket is already full of product solids so the emissions that occur from the centrifuge would be from the gas sweep assuming that a gas sweep exists. However, if the centrifuge is tightly connected to other ancillary equipment items and a gas purge is not being used at the centrifuge then the focus of the emission calculation would be placed on the filtrate receiver.

The volume of wash solvent that enters the filtrate receiver in conjunction with any gas sweep that also might be present forms the basis for the emission calculation from the filtrate receiver.

5.4 Vacuum Dryer Model

Examples of vacuum drying include processing when final product solids are dried in a vacuum tray dryer or rotary dryer.

The vacuum drying process consists of at least four separate activities and includes (1) placing the process material into the dryer, (2) reducing the system pressure to the design level (3) heating the batch for evaporation to take place, and (4) collecting the solvent distillate in the receiver.

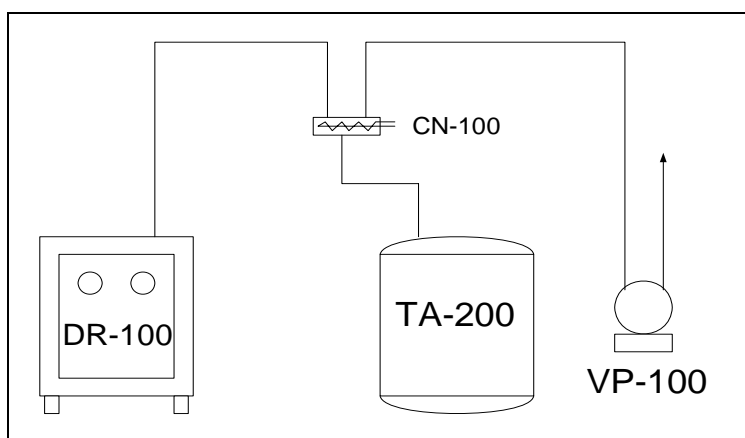

Figure 5-3. Diagram of a typical vacuum tray dryer system.

5.4.1 Information Needed to Model a Vacuum Tray Drying Operation

5.4.1.1 Placing the material to be dried into the vacuum oven

Product solids that are wet with solvent from the prior filtration or centrifugation step will undergo evaporation losses as they are being prepared for the vacuum dryer. Material to be dried is physically transferred from a hopper, drum, or other container onto trays and then spread evenly so that the drying process will be uniform.

It is difficult to predict the evaporation rate from wet solids because each process is different and the material being processed varies with respect to particle size, solvent content, exposure condition, and other variables. A conservative approach to estimating the evaporation losses from a wet product solids cake would be to apply the basic evaporation model as presented in Section 3.6 of this document.

$$Q_m = \frac{M_i K_i A (P_i^{sat} - P_i)}{RT_L} \quad \text{Eq. 5-1}$$

- where Q_m is the evaporation rate (mass/time),
 M is the molecular weight of the volatile substance,
 K is a mass transfer coefficient (length/time),
 A is the evaporation surface area,
 P_i^{sat} is the saturated solvent vapor pressure,
 P_i is the actual vapor pressure near the liquid surface,

R is the ideal gas constant, and
 T_L is the absolute temperature of the liquid.

Equation 5-1 would provide a conservative estimate of the evaporation rate because the solvent is distributed throughout the product cake as opposed to existing as a continuous liquid with a fixed surface area. As evaporation takes place the amount of solvent that is close to the surface of the cake becomes depleted and any remaining solvent must migrate to the surface for further evaporation. The evaporation process will also remove heat from the product cake and cause P_i^{sat} to reduce due to the lower temperature.

An alternative approach to quantifying the evaporation rate would be to perform a material balance study by making weight loss measurements using representative samples of wet cake. The results from wet loss studies could then be used to make future estimates.

5.4.1.2 Depressurization Step

The standard depressurization model is applied to calculate the solvent emissions from vacuum oven during the evacuation operation from one atmosphere down to the planned operating pressure. In many cases the planned operating pressure for the oven is less than the saturation vapor pressure of the solvent. In these cases, the depressurization model would be calculated between one atmosphere and the solvent saturated vapor pressure.

5.4.1.3 Heating Step

If the planned operating pressure of the vacuum oven is less than the solvent saturated vapor pressure at initial temperature conditions then the heating model can be used to estimate the emissions that occur during heat up. The heating model would be calculated between the initial temperature conditions and within 2°C of the boiling point temperature for the solvent at the planned operating pressure of the vacuum oven.

5.4.1.4 Distillation Step

Once the drying process is underway, solvent vapors are carried from the vacuum oven and into the heat exchanger where they condense and drain into the distillate receiver. The distillate receiver continues to fill with solvent as long as solvent is being removed from the product solids. Air emissions that occur while the vacuum drying process is ongoing originate from the distillate receiver. The vacuum pump continually removes air from the equipment to maintain the correct pressure of operation.

The filling model is used to estimate the solvent emissions during this part of the drying process. The composition and quantity of the distillate being collected is the same as the original amount of solvent that was contained in the wet cake. The fill volume is equal to the total volume of solvent that is collected. The temperature and pressure of the distillate receiver is used in the calculations as well as any estimated leak rate that the vacuum pump must overcome as part of the process operation.

[This page intentionally left blank.]

6.0 Physical Property Relationships

6.1 Basic Physical Properties Relationships

This section describes the equations and mathematical relationships that are used in calculating air emissions from point sources in chemical manufacturing processes.

6.1.1 Unit Conversations

The following relationships are helpful when converting from one unit system to another for temperatures, pressures, and volumes.

Temperature Conversions

$$T (^{\circ}\text{R}) = T (^{\circ}\text{F}) + 459.69 \quad \text{Eq. 6-1}$$

$$T (^{\circ}\text{K}) = T (^{\circ}\text{C}) + 273.15$$

$$T (^{\circ}\text{K}) = 1.8 * T (^{\circ}\text{R})$$

$$T (^{\circ}\text{K}) = [T (^{\circ}\text{F}) + 459.69] / 1.8$$

$$T (^{\circ}\text{C}) = T (^{\circ}\text{K}) - 273.15$$

$$T (^{\circ}\text{C}) = [T (^{\circ}\text{F}) - 32.0] / 1.8$$

Pressure Conversions

$$P (\text{mm Hg}) = 760.0 * P (\text{atm}) \quad \text{Eq. 6-2}$$

$$P (\text{mm Hg}) = 51.7 * P (\text{psia})$$

$$P (\text{mm Hg}) = 25.4 * P (\text{in Hg})$$

$$P (\text{mm Hg}) = P (\text{Pa}) / 133.3$$

Volume Conversions

$$V \text{ ft}^3 = 0.03531467 * V (\text{liter}) \quad \text{Eq. 6-3}$$

$$V \text{ ft}^3 = 0.133680555 * V (\text{gal})$$

6.2 Basic Physical Property Relationships

6.2.1 Ideal Gas Law

The Ideal Gas Law is used to calculate the total number of moles in a gas space from known variables, such as pressure, volume, and temperature.

$$PV = nRT \quad \text{Eq. 6-4}$$

where: n = moles of gas
 P = pressure (absolute)
 V = volume
 T = temperature (absolute)
 R = Universal Gas Constant

The following properties exist for ideal gases at the standard temperature and pressure condition:

Table 6-1. Standard Conditions for Ideal Gases

Mass	Pressure	Volume	Temperature	Ideal Gas Constant (R)
1.0 lb-mole	14.7 lb/in ²	359.046 ft ³	491.69°R	10.731
1.0 lb-mole	29.92 in Hg	359.046 ft ³	491.69°R	21.8484
1.0 lb-mole	760 mm Hg	359.046 ft ³	273.15°K	998.9
1.0 g-mole	760 mm Hg	22.414 liters	273.15°K	62.3637
1.0 g-mole	1.0 atm	22.414 liters	273.15°K	0.8206

Illustration 6-1: Calculating the moles of gas from volume, temperature, and pressure.

A process vessel has a void space volume of 1200 gallons when empty of liquid. Calculate the moles of gas that are discharged from the process vent if 550 gallons of liquid are charged into the vessel. Also calculate the moles of gas that are still contained in the vessel headspace at the completion of the filling operation. The batch temperature is 35°C and the system pressure is 760 mm Hg.

Assumptions: The vessel temperature and the batch temperature are the same 35°C before and after the addition is made. Additionally, any evaporation that may occur when the liquid enters the initially empty vessel is ignored.

Part A (Moles of gas displaced through the process vent).

Displacement Volume $V_d = 550 \text{ gal} = 0.133680555 \text{ ft}^3/\text{gal} * 550 \text{ gal} = 73.52 \text{ ft}^3$

Temperature $T = 35^\circ\text{C} = 35^\circ\text{C} + 273.15^\circ\text{K} = 308.15^\circ\text{K}$

$$\text{Moles} \quad n = \left(\frac{PV}{RT} \right) = \left(\frac{760 * 73.52}{998.99 * 308.15} \right) = 0.182 \text{ lb - moles}$$

Part B (Moles of gas retained in the vessel headspace).

Gas Space Volume $V_g = 1200 \text{ gal} - 550 \text{ gal} = 650 \text{ gal}.$

Volume conversion $V_g = 0.133680555 \text{ ft}^3/\text{gal} * 650 \text{ gal} = 86.89 \text{ ft}^3$

$$\text{Moles} \quad n = \left(\frac{PV}{RT} \right) = \left(\frac{760 * 86.89}{998.99 * 308.15} \right) = 0.215 \text{ lb - moles}$$

6.2.2 Dalton's Law

Equations based on Dalton's Law (Eq. 6-5) of partial pressure and Amagat's law (Eq. 6-6) of partial volume are used with the Ideal Gas Law to determine the number of moles of a specific compound in the vapor space of the vessel.

$$\text{Dalton's Law} \quad n_i = \frac{p_i V}{RT} \quad \text{Eq. 6-5}$$

$$\text{Amagat's Law} \quad n_i = \frac{P v_i}{RT} \quad \text{Eq. 6-6}$$

where: P = pressure
V = volume

T = temperature
 R = Universal Gas Constant
 n_i = moles of i
 p_i = partial pressure of i
 v_i = partial volume of i

Illustration 6-2: Calculating molar quantities for gas mixtures.

The headspace of a vessel contains the vapors of water (20 mm Hg), methanol (45 mm Hg), ethanol (40 mm Hg), and a non-condensable component nitrogen. How many moles of each compound are contained in the headspace if the batch temperature is 35°C, the head space volume is 453 gallons, and the total system pressure is 760 mm Hg.

Gas Volume $V = 453 \text{ gal} * 0.133680555 \text{ ft}^3/\text{gal} = 60.56 \text{ ft}^3$

Temperature (°K) $T = 35^\circ\text{C} = 35^\circ\text{C} + 273.15^\circ\text{K} = 308.15^\circ\text{K}$

Dalton's Law $n_i = \frac{p_i V}{RT}$

Moles of water $n_{\text{water}} = \left(\frac{p_i V}{RT} \right) = \left(\frac{20 * 60.56}{998.99 * 308.15} \right) = 0.00393 \text{ lb - moles}$

Moles of methanol $n_{\text{methanol}} = \left(\frac{p_i V}{RT} \right) = \left(\frac{45 * 60.56}{998.99 * 308.15} \right) = 0.00885 \text{ lb - moles}$

Moles of ethanol $n_{\text{ethanol}} = \left(\frac{p_i V}{RT} \right) = \left(\frac{40 * 60.56}{998.99 * 308.15} \right) = 0.00787 \text{ lb - moles}$

Partial pressure of nitrogen $p_{\text{nitrogen}} = 760 - 20 - 40 - 45 = 655 \text{ mmHg}$

Moles of nitrogen $n_{\text{methanol}} = \left(\frac{p_i V}{RT} \right) = \left(\frac{45 * 60.56}{998.99 * 308.15} \right) = 0.00885 \text{ lb - moles}$

6.2.3 Mole Fraction in a Liquid

The ratio of moles of i to the total moles in a single liquid phase is defined as mole fraction, X_i . The liquid mole fraction of a compound is used later for calculating the vapor pressure for the same compound using Raoult's Law.

Mole fraction $x_i = \frac{n_i}{n_{\text{total}}}$ Eq. 6-7

where: x_i = mole fraction for component i
 n_i = moles of i in a single liquid phase
 n_{total} = total moles in a single liquid phase

Illustration 6-3: Calculating mole fractions for liquid mixtures.

A process batch consist of methanol (1,435 lb), isopropyl alcohol (546 lb), and acetone (584 lb). Determine the mole fraction (X_i) of each compound in the solution.

Compound	Weight	Molecular Weight
Methanol	1,435 lb	32.04
Isopropyl alcohol	546 lb	60.096
Acetone	584 lb	58.08

moles of methanol:
$$n = \frac{1,435 \text{ lb}}{32.04 \text{ mwt}} = 44.79 \text{ lb - moles}$$

moles of isopropyl alcohol:
$$n = \frac{546 \text{ lb}}{60.096 \text{ mwt}} = 9.09 \text{ lb - moles}$$

moles of acetone:
$$n = \frac{584 \text{ lb}}{58.08 \text{ mwt}} = 10.06 \text{ lb - moles}$$

Total moles in the batch:
$$44.79 + 60.096 + 10.03 = 69.93 \text{ lb-moles}$$

mole fraction of methanol:
$$n = \frac{546 \text{ lb}}{60.096 \text{ mwt}} = 9.09 \text{ lb - moles}$$

mole fraction of isopropyl alcohol:
$$X_i = \frac{9.09 \text{ lb - moles}}{69.93 \text{ lb - moles}} = 0.142$$

mole fraction of acetone:
$$X_i = \frac{10.06 \text{ lb - moles}}{69.93 \text{ lb - moles}} = 0.157$$

6.3 Pure Component Vapor Pressure**6.3.1 Clapeyron Vapor Pressure Equation**

Essentially, all liquids and some solids exhibit a vapor pressure that can be measured. The vapor pressure for any compound is a function of temperature and composition within a given solution. If the compound exists in pure form then the vapor pressure becomes only a function of temperature.

Many mathematical relationships have been formulated over the years that enable the pure component vapor pressure of a compound to be accurately estimated within a given temperature range. The Clapeyron Vapor Pressure Model (*Eq. 6-8*) is based upon the equality of chemical potential, temperature, and pressure in both liquid and gas phases. [Reid, Prausnitz, & Sherwood, 1977]

Clapeyron model
$$\ln(P_i) = A - \frac{B}{T} \quad \text{Eq. 6-8}$$

where P_i = pure component vapor pressure
 T = temperature, degrees Kelvin
 A = empirical constant
 $B = \Delta H_v / R \Delta Z_v$ (ΔH_v - heat of vaporization, ΔZ_v - compressibility factor).

Although the Clapeyron Vapor Pressure model is based on the heat of vaporization and the compressibility factor for a compound, this thermodynamic data is not needed. If two reliable vapor pressure data points can be obtained then A and B can be determined mathematically. However, one disadvantage to using this model is that the vapor pressure correlation may not be as accurate as other models that contain a greater number of empirical coefficients.

Illustration 6-4: Estimating Clapeyron vapor pressure model coefficients.

Toluene has a boiling point of 110.6°C at 760 mm Hg. and a boiling point of 31.8°C at 40 mm Hg. Determine A and B for the Clapeyron Vapor Pressure model and then calculate the vapor pressure of toluene at 51.9 C.

Clapeyron model $\ln(P) = A - \frac{B}{T}$

(a) Solve for B

$$\ln(P_2) - \ln(P_1) = -B(T_2^{-1} - T_1^{-1})$$

$T_1 = 31.8 \text{ C} = 31.8 + 273.15 = 304.95 \text{ K}$ $1/T_1 = 0.0032792$
 $\ln(P_1) = \ln(40) = 3.6888795$ $\ln(P_1) = 3.6888795$
 $T_2 = 110.6 \text{ C} = 110.6 + 273.15 = 383.75 \text{ K}$ $1/T_2 = 0.0026059$
 $\ln(P_2) = \ln(760) = 6.6333184$ $\ln(P_2) = 6.6333184$

Solve for B:

$$B = - \left[\frac{\ln(P_2) - \ln(P_1)}{T_2^{-1} - T_1^{-1}} \right]$$

$$B = - \left[\frac{6.6333184 - 3.6888795}{0.0026059 - 0.0032792} \right] = 4372.7371$$

Solve for A

$$A = \ln(P_2) + \frac{B}{T_2} = 6.6333184 + \frac{4372.7371}{383.75} = 18.0281$$

Calculate the vapor pressure of toluene at 51.9 C (325.05 K)

$$\ln(P) = A - \frac{B}{T} = 18.0281 - \frac{4372.7371}{325.05} = 4.575567$$

$P_{51.9\text{C}} = 97.1 \text{ mm Hg.}$

Note that the vapor pressure of toluene from literature sources is 100 mm Hg for 51.9 C or 3% higher than the Clapeyron model prediction using this technique.

6.3.2 Antoine Equation

The Antoine equation is a modification of the Clapeyron model and is one of the most frequently used equations for estimating the vapor pressure of a pure compound. [Reid, Prausnitz, & Sherwood, 1977]

The Antoine equation is shown in the following general form:

$$\ln(P_i) = \left(a_i - \frac{b_i}{T + c_i} \right) \quad \text{Eq. 6-9}$$

where: P_i = pure component pressure of compound i

T = absolute temperature

a_i, b_i, c_i = Antoine constants

Coefficients a_i , b_i , and c_i are published in several literature sources for many compounds. It is important to note the specific temperature and pressure units that are associated with the Antoine coefficients that are listed in the literature.

The reader should keep in mind that the Antoine equation is a general mathematical relationship and can be used with temperatures in either Centigrade, Kelvin, Fahrenheit, or Rankin units. Additionally, the equation can be used for calculating vapor pressures in different units (atm, mm Hg, and psia) and in the natural log (ln) or base 10 log form. It is always a good idea to calculate one or more known vapor pressure data points as a means of verifying that the model is consistent with respect to coefficients, temperature units, and pressure units being used.

Illustration 6-5: Calculating pure component vapor pressures from the Antoine model.

The Antoine coefficients for toluene are $a = 16.0137$, $b = 3096.52$, and $c = -53.67$. These coefficients were obtained from a source where the Antoine equation is in the natural log form, pressure is in mm Hg, and temperature is in Kelvin units. Additionally, these coefficients are valid between 7°C and 137°C. What is the pure component vapor pressure for toluene at 35°C and 70°C?

Antoine Equation	$\ln(P_i) = \left(a_i - \frac{b_i}{T + c_i} \right)$
Temperature (35°C)	$T = 35^\circ\text{C} = 35.0^\circ\text{C} + 273.15^\circ\text{K} = 308.15^\circ\text{K}$ $\ln(P_i) = \left(16.0137 - \frac{3096.52}{308.15 - 53.67} \right) = 3.8457$ $P_{35^\circ\text{C}} = e^{3.8457} = 46.79 \text{ mm Hg.}$
Temperature (70°C)	$T = 70^\circ\text{C} = 70.0^\circ\text{C} + 273.15^\circ\text{K} = 343.15^\circ\text{K}$ $\ln(P_i) = \left(16.0137 - \frac{3096.52}{343.15 - 53.67} \right) = 5.3169$ $P_{70^\circ\text{C}} = e^{5.3169} = 203.74 \text{ mm Hg.}$

6.3.3 Other Vapor-Pressure Equation Forms

Over the years researchers have published many different equations for calculating the vapor pressure of pure compounds as a function of temperature. [Reid, Prausnitz, & Sherwood, 1977] Among these include:

$$\text{Riedel-Plank-Miller Equation:} \quad \ln P_{vp} = A + \frac{B}{T} + CT + DT^3 \quad \text{Eq. 6-10}$$

$$\text{Rankine-Kirchhoff Equation:} \quad \ln P_{vp} = A + \frac{B}{T} + C \ln T \quad \text{Eq. 6-11}$$

$$\text{Riedel Equation:} \quad \ln P_{vp} = A + \frac{B}{T} + C \ln T + DT^6 \quad \text{Eq. 6-12}$$

Coefficients that apply to each equation are normally provided through commercially available databases. The DIPPER Database (AIChE) provides modeling coefficients for an equation of the general form:

$$\ln P_{vp} = A + \frac{B}{T} + C \ln T + DT^E \quad \text{Eq. 6-13}$$

Where P_{vp} = vapor pressure in Pascal (Pa) units.
 T = temperature in degrees Kelvin.

Illustration 6-6: Calculating vapor pressures using the AIChE DIPPR database model.

According to the AIChE DIPPR Database, the vapor pressure coefficients for acetone are as follows:

$$\begin{aligned} A &= 69.006 & B &= -5599.6 \\ C &= -7.0985 & D &= 0.0000062237 \\ E &= 2.0000 \end{aligned}$$

What is the vapor pressure of acetone if the temperature of the liquid is 25°C?

$$T = 25^\circ\text{C} + 273.15 = 298.15^\circ\text{K}$$

$$\ln P_{vp} = 69.006 - \frac{5599.6}{T} - 7.098 \ln T + 0.0000062237T^2$$

$$\ln P_{vp} = 69.006 - 18.781 - 40.444 + 0.553 = 10.334$$

$$P_{vp} = 3.074 \times 10^4 \text{ Pa} \times \frac{1 \text{ mmHg}}{133.35 \text{ Pa}} = 230.697 \text{ mmHg}$$

6.4 Component Vapor Pressure over Solutions

6.4.1 Equilibrium Conditions (Ideal) and Raoult's Law

Ideal vapor pressure conditions normally exist for a solution when strong molecular associations between molecules are not present. This is normally the case when the molecular sizes are approximately equal and the attractive forces between like and unlike molecules are equal as well. Ideal equilibrium conditions are typically present when the solution is made up completely of nonpolar compounds such as organic solvents (toluene, heptane, hexane, etc.).

A generalization known as Raoult's Law states that the equilibrium vapor pressure that is observed for a compound is proportional to the mole fraction of that compound in solution. For example, given an equal

molar solution (0.5:0.5) of toluene and heptane at 35°C, the equilibrium vapor pressure of the toluene would be 101.87 mm Hg or one half of its pure component vapor pressure of 203.74 mm Hg at 35°C.

$$\text{Raoult's Law } p_i = X_i P_i$$

where: p_i = effective vapor pressure of i

P_i = pure component pressure i

X_i = mole fraction of component i

Illustration 6-7: Estimating component vapor pressures using Raoult's Law.

A solution contains 20% toluene (wt/wt), 50% heptane (wt/wt), 30% acetone. The solution temperature is 35°C. The pure component vapor pressures for toluene, heptane, and acetone are 46.79 mm Hg, 74.04 mm Hg, and 347.1 mm Hg respectively for the 35°C condition. The molecular weights for toluene, heptane, and acetone are 92.13, 100.205, and 58.08, respectively.

Calculate the moles and mole fraction of each component in the solution on a 100 lb basis.

$$\text{Moles of toluene } n_{\text{toluene}} = \left(\frac{\text{wt}_{\text{toluene}}}{\text{MW}_{\text{toluene}}} \right) = \left(\frac{20 \text{ lb}}{92.13} \right) = 0.22 \text{ lb - moles}$$

$$\text{Moles of heptane } n_{\text{heptane}} = \left(\frac{\text{wt}_{\text{heptane}}}{\text{MW}_{\text{heptane}}} \right) = \left(\frac{50 \text{ lb}}{100.205} \right) = 0.50 \text{ lb - moles}$$

$$\text{Moles of acetone } n_{\text{acetone}} = \left(\frac{\text{wt}_{\text{acetone}}}{\text{MW}_{\text{acetone}}} \right) = \left(\frac{30 \text{ lb}}{58.08} \right) = 0.52 \text{ lb - moles}$$

$$\text{Sum of moles } n_{\text{total}} = 0.22 + 0.50 + 0.52 = 1.23 \text{ lb-moles}$$

$$\text{Mole fraction of toluene } X_{\text{toluene}} = \left(\frac{\text{moles}_{\text{toluene}}}{\text{total moles}} \right) = \left(\frac{0.22}{1.23} \right) = 0.176$$

$$\text{Mole fraction of heptane } X_{\text{heptane}} = \left(\frac{\text{moles}_{\text{heptane}}}{\text{total moles}} \right) = \left(\frac{0.50}{1.23} \right) = 0.405$$

$$\text{Mole fraction of acetone } X_{\text{acetone}} = \left(\frac{\text{moles}_{\text{acetone}}}{\text{total moles}} \right) = \left(\frac{0.52}{1.23} \right) = 0.419$$

Calculate the equilibrium vapor pressure for each component.

$$\text{Vapor pressure for of toluene } p_{\text{toluene}} = 0.176 * 46.79 = 8.24 \text{ mm Hg}$$

$$\text{Vapor pressure for of heptane } p_{\text{heptane}} = 0.405 * 74.04 = 29.97 \text{ mm Hg}$$

$$\text{Vapor pressure for of acetone } p_{\text{acetone}} = 0.419 * 347.1 = 145.46 \text{ mm Hg}$$

6.4.1.1 Using Raoult's Law to determine molar concentration

In special cases, Raoult's Law can be used to determine the molar concentration of a single solvent solution. For example, suppose waste solvent from a process contains dissolved non-volatile or very low volatile compounds (such as heavy oil). The boiling point temperature of waste solvent and the pure solvent is measured. The molar concentration of the primary solvent in the waste solvent solution may be determined by dividing 760 mm Hg by the calculated vapor pressure of the pure solvent at the elevated temperature.

Illustration 6-8: Estimating liquid composition based on vapor pressure measurements.

The boiling point temperature of a sample of waste toluene was measured to be 112.3°C. The boiling point temperature of a sample of pure toluene was measured to be 110.8°C. (Note that measuring the boiling point temperature of a pure solvent can result in a different reading than the value that is contained in the literature due to atmospheric elevation differences and measurement accuracy issues.)

Boiling point difference between the two samples (112.3°C – 110.8°C): 1.5°C.

Normal boiling point temperature of toluene from the literature: 110.6°C.

Corrected boiling point of the waste toluene sample (110.6°C + 1.5°C): 112.1°C

$$\ln(P_i) = \left(16.0137 - \frac{3096.52}{385.25 - 53.67}\right) = 6.675$$

$$P_{112.1^\circ\text{C}} = e^{6.675} = 792.362 \text{ mm Hg.}$$

Raoult's Law

$$p_i = x_i P_i$$

Molar concentration:

$$x_i = \frac{p_i}{P_i} = \frac{760.0 \text{ mmHg}}{792.362 \text{ mmHg}} \times 100\% = 95.9\%$$

Illustration 6-9: Determining the molar composition of a liquid from vapor pressure data.

A mixture has been prepared for processing at 35°C. The contents contain 850 lbs of toluene, 525 lbs of heptane, and 2,500 lbs of other non-volatile materials. Determine the vapor pressure of the mixture at 35°C and the mole fraction of toluene and heptane. The molecular weight of toluene is 92.13 and the molecular weight of heptane is 100.2.

The molar quantities of toluene and heptane are calculated

$$\text{Moles of toluene} \quad n_{\text{toluene}} = \left(\frac{wt_{\text{toluene}}}{MW_{\text{toluene}}}\right) = \left(\frac{850 \text{ lb}}{92.13}\right) = 9.22 \text{ lb - moles}$$

$$\text{Moles of heptane} \quad n_{\text{heptane}} = \left(\frac{wt_{\text{heptane}}}{MW_{\text{heptane}}}\right) = \left(\frac{525 \text{ lb}}{100.205}\right) = 5.24 \text{ lb - moles}$$

A sample of the process mixture is placed in a vacuum flask equip with a temperature probe, reflux condenser, vacuum pump, vacuum controller, and pressure gauge. The mixture is heated to 35°C and then placed under increasing vacuum until the mixture begins to boil with reflux present. The boiling point pressure is recorded from this experiment to be 40 mm Hg. The pure vapor pressures for toluene and heptane at 35°C are 45.79 mm Hg and 74.04 mm Hg, respectively.

For this mixture the volatile components have been identified to consist entirely of toluene and heptane. However, the mole fraction of these two components cannot be determined because the molecular weight

data for the remaining components is not available. Therefore, the following general equation can be established that relates the unknown mole fraction to the partial pressure for each volatile compound.

$$\text{Raoult's Law} \quad p_i = x_i P_i = \frac{n_i}{\sum n} P_i$$

$$\text{Mole fraction in gas space} \quad y_i = \frac{p_i}{\sum p}$$

$$\text{Combining equations} \quad y_i = \frac{n_i P_i}{\sum n P_i} \quad \text{Eq. 6-14}$$

Finally, the liquid mole fraction for each volatile component may be determined from Raoult's Law.

$$x_i = \frac{p_i}{P_i} = \frac{y_i P_T}{P_i} \quad \text{Eq. 6-15}$$

For this problem only toluene and heptane need to be considered. Eq. 6-14 is customized to accommodate only toluene and heptane.

$$\text{For toluene} \quad y_i = \frac{n_i P_i}{n_i P_i + n_j P_j} = \frac{(9.22 \times 45.79)}{(9.22 \times 45.79) + (5.24 \times 74.04)} = 0.521$$

$$\text{For heptane} \quad y_j = \frac{(5.24 \times 74.04)}{(9.22 \times 45.79) + (5.24 \times 74.04)} = 0.479$$

Finally,

$$\text{For toluene} \quad x_i = \frac{y_i P_T}{P_i} = \frac{0.521 \times 40.0}{45.79} = 0.455$$

$$\text{For heptane} \quad x_j = \frac{y_j P_T}{P_j} = \frac{0.479 \times 40.0}{74.04} = 0.258$$

The results of these calculations suggest that 0.286 (or $1.0 - 0.455 - 0.258$) mole fraction of the process mixture consist of other nonvolatile components.

6.4.2 Non-Ideal Equilibrium Conditions and Activity Coefficients

In many cases, ideal equilibrium relationships do not exist for solutions. This is especially true for solutions containing compounds that are polar in nature or have significant attraction to other compounds in the same solution. An example of a solution with highly non ideal equilibrium properties is aqueous hydrochloric acid with the vapor pressure of hydrogen chloride being orders of magnitude lower than expected by Raoult's Law. Other examples of solutions with non ideal vapor pressure behavior would include systems with azeotropic properties such as acetone – hexane.

Non ideal equilibrium systems should be calculated using an activity coefficient (or correction factor) as part of the basic equilibrium calculation. The equilibrium vapor pressure equation for ideal solutions has been modified to include the activity coefficient as part of the calculation. For solutions that exhibit ideal behavior the activity coefficient is defaulted to 1.0. For solutions that exhibit significant non ideal vapor pressure behavior the activity coefficient may be estimated from known vapor pressure data. Eq. 6-16

shows how the vapor pressure of a component in solution would be calculated using the Antoine vapor pressure model.

$$p_i = X_i \gamma_i P_i = X_i \gamma_i \exp\left(a_i - \frac{b_i}{c_i + T}\right) \quad \text{Eq. 6-16}$$

where: p_i = effective vapor pressure of i
 P_i = pure component pressure i
 X_i = mole fraction of component i
 γ_i = activity coefficient for component i
 T = absolute temperature
 a_i, b_i, c_i = Antoine constants

Illustration 6-10: Estimating activity coefficients from solution measurements.

Using Raoult's Law the pure component vapor pressure of ammonia over a 19.1% (wt/wt) aqueous solution of ammonia acid at 21.1°C is 1308 mm Hg and the vapor pressure of water is 14.9 mm Hg. The measured vapor pressures of ammonia and water are 221.2 mm Hg and 14.5 mm Hg, respectively.

What are the activity coefficients for ammonia and water under these conditions?

$$\text{Activity Coefficient } \gamma_{NH_3} = \frac{221.3 \text{ mmHg}}{1308 \text{ mmHg}} = 0.16917$$

$$\text{Activity Coefficient } \gamma_{Water} = \frac{14.47 \text{ mmHg}}{14.9 \text{ mmHg}} = 0.972$$

Assuming that the activity coefficients remain constant between 10°C and 30°C, what would the vapor pressure of hydrogen chloride and water be for the same solution at 25°C?

Based on 100 lbs of solution,

$$\text{Mole fraction of } NH_3: \frac{19.1/17.031}{19.1/17.031 + 79.9/18.02} = 0.20$$

$$\text{Mole fraction of } H_2O: \frac{79.9/18.02}{79.9/18.02 + 19.1/17.031} = 0.80$$

At 25 C the calculated pure vapor pressure for NH_3 and H_2O are 7,370 mm Hg and 23.58 mm Hg, respectively.

$$\text{Vapor pressure of } NH_3: P_{NH_3} = P_{NH_3} \gamma_{NH_3} X_{NH_3} = 0.20 * 0.16917 * 7370 = 249.3 \text{ mm Hg}$$

$$\text{Vapor pressure of } H_2O: P_{H_2O} = X_{H_2O} \gamma_{H_2O} P_{H_2O} = 0.80 * 0.972 * 23.58 = 18.35 \text{ mm Hg}$$

Illustration 6-11: Estimating activity coefficients from azeotropic mixtures.

The azeotropic composition of a solution containing heptane and methanol is 48.5% (wt/wt) and 51.5% (wt/wt), respectively. The azeotropic boiling point for the solution is 59.1°C and the system pressure is 760 mm Hg. Based on Raoult's Law, the calculated vapor pressures for the same solution of heptane and

methanol are 47.9 mm Hg and 470.1 mm Hg, respectively. Note that the liquid and vapor compositions for an azeotropic system are the same at the boiling point.

For this problem the composition of heptane and methanol must be converted from weight percent to mole percent. This may be accomplished by basing the calculations for an arbitrary 100 lb of solution and then calculating the moles of each compound using the molecular weight. Finally, the mole fraction of each compound is calculated by dividing the moles of each compound by the total moles in the solution. The 48.5% (wt/wt) for heptane is converted to 23.1% (mole/mole), and the 51.5% (wt/wt) for methanol becomes 76.9% (mole/mole).

Calculate the activity coefficients for heptane and methanol under these conditions.

$$\gamma_{\text{heptane}} = \frac{0.231 * 760 \text{ mmHg}}{47.9 \text{ mmHg}} = 3.672$$

$$\gamma_{\text{methanol}} = \frac{0.769 * 760 \text{ mmHg}}{470 \text{ mmHg}} = 1.243$$

Illustration 6-12: Calculating vapor compositions using activity coefficients.

A solution of heptane and methanol was distilled at its azeotropic composition for 1 atm pressure. If the temperature of the recovered distillate is 30°C, what would be the vapor composition for this solution? The system pressure is 760 mm Hg and the vessel is blanketed with nitrogen.

Vapor pressures at 30°C:

Heptane = 58.54 mm Hg.

Methanol = 163.8 mm Hg.

Azeotropic composition:

Heptane = 48.5% (wt/wt) = 23.1% (mole/mole)

Methanol = 51.5% (wt/wt) = 76.9% (mole/mole)

Component vapor pressure

$$P_{\text{heptane}} = X_{\text{heptane}} \gamma_{\text{heptane}} P_{\text{heptane}} = 0.231 * 3.672 * 58.54 = 50 \text{ mm Hg}$$

$$P_{\text{methanol}} = X_{\text{methanol}} \gamma_{\text{methanol}} P_{\text{methanol}} = 0.769 * 1.243 * 163.8 = 157 \text{ mm Hg}$$

$$P_{\text{nitrogen}} = 760 - 50 - 157 = 553 \text{ mm Hg}$$

Vapor space molal percentage compositions y_i :

$$y_{\text{heptane}} = \frac{50}{760} * 100\% = 6.6\%$$

$$y_{\text{methanol}} = \frac{156}{760} * 100\% = 20.5\%$$

$$y_{\text{nitrogen}} = \frac{553}{760} * 100\% = 72.9\%$$

7.0 References

- Alkis Constantinides, “Applied Numerical Methods with Personal Computers”, 1987, ISBN 0-07-012463-9, McGraw-Hill, Inc., pp 76-78, pp 132-134, pp 276-277.
- Crowl, Daniel and Louvar, Joseph. 2002. *Chemical Process Safety, Fundamentals with Applications*. Second Edition. Prentice Hall PTR, Upper Saddle River, NJ 07458. www.phptr.com. ISBN: 0-13-018176-5.
- EIIP. 2000. How to Incorporate The Effects of Air Pollution Control Device Efficiencies and Malfunctions Into Emission Inventory Estimates. Chapter 12 in EIIP Volume II. Point Sources Preferred and Alternative Methods. U.S. Environmental Protection Agency, Office of Air Quality Planning and Standards. Research Triangle Park, North Carolina. (EIIP Internet address <http://www.epa.gov/ttn/chief/eiip>).
- EPA. 1987. *Estimating Releases and Waste Treatment Efficiencies for the Toxic Chemical Release Inventory Form*. U.S. Environmental Protection Agency, Office of Pesticides and Toxic Substances, EPA-560/4-88-002. Washington, D.C.
- EPA. 1994a. *Air Emissions Models for Waste and Wastewater*. U.S. Environmental Protection Agency, Office of Air Quality Planning and Standards, EPA-453/R-94-080a. Research Triangle Park, North Carolina.
- EPA. 1994c. *Control of Volatile Organic Compound Emissions from Batch Processes -Alternate Control Techniques*. U.S. Environmental Protection Agency, Office of Air Quality Planning and Standards, EPA-453/R-93-017. Research Triangle Park, North Carolina.
- EPA. 1995a. Compilation of Air Pollutant Emission Factors. Volume I: Stationary Point and Area Sources, Fifth Edition, AP-42. Section 7.1, Organic Liquid Storage Tanks. U.S. Environmental Protection Agency, Office of Air Quality Planning and Standards. Research Triangle Park, North Carolina.
- EPA. 1995g. *Protocol for Equipment Leak Emission Estimates*. U.S. Environmental Protection Agency, Office of Air Quality Planning and Standards, EPA-453/R-95-017. Research Triangle Park, North Carolina.
- EPA. 1995h. *Survey of Control Technologies for Low Concentration Organic Vapor Gas Streams*. U.S. Environmental Protection Agency, Office of Research and Development, EPA-456/R-95-003. Research Triangle Park, North Carolina. (Internet address, http://www.epa.gov/ttn/catc/dir1/low_vo.pdf)
- Ernest J. Henley & J. D. Seader, “Equilibrium-Stage Separation Operations in Chemical Engineering”, 1981, ISBN 0-471-37108-4, John Wiley & Sons.
- H. H. Rachford, Jr. and J. D. Rice, *J. Pet. Tech.*, 4 (10), Section 1, p. 19, and Section 2, p. 3 (October, 1952).
- Hatfield, J. A. (a). “A Model for Estimating Process Emissions from Purge Operations in Batch and Continuous Chemical Operations”, Accepted for Publication in *Environmental Progress*, August 14, 2003.

- Hatfield, J. A. (b). “Improved Algorithm for Estimating Process Emissions from Batch Depressurization”, *Environmental Progress*, Vol. 17 No. 3, pp. 195-198 (Fall 1998).
- Hatfield, J. A. (c). “Improved Algorithm for Estimating Process Emissions from Batch Heating”, *Environmental Progress*, Vol. 17 No. 3, pp. 190-194 (Fall 1998).
- Hatfield, J. A. (d). “Subsurface Addition Emission Model”, Accepted for Publication in *Environmental Progress*, November 24, 2003.
- Hougen, Olaf and Watson, Kenneth and Ragatz, Roland. 1958. *Chemical Process Principles, Part I*. Second Edition. John Wiley & Sons, Inc. New York, NY.
- Hougen, Watson, & Ragatz, “Chemical Process Principles”, 1959, ISBN 0-471-41382-8, John Wiley & Sons. pp 919.
- Perry. 1984. *Perry's Chemical Engineers' Handbook, 6th Edition*. 1984, McGraw-Hill Book Company. ISBN 0-07-049479-7.
- Phillip C. Wankat, “Separations in Chemical Engineering, Equilibrium Stage Separations”, 1988, ISBN 0-13-500968-5, Prentice-Hall P T R.
- Reid, Robert and Prausnitz, John and Sherwood, Thomas. 1977. *The Properties of Gases and Liquids*. Third Edition. McGraw-Hill Book Company. ISBN: 0-07-051790-8.