

Radiation

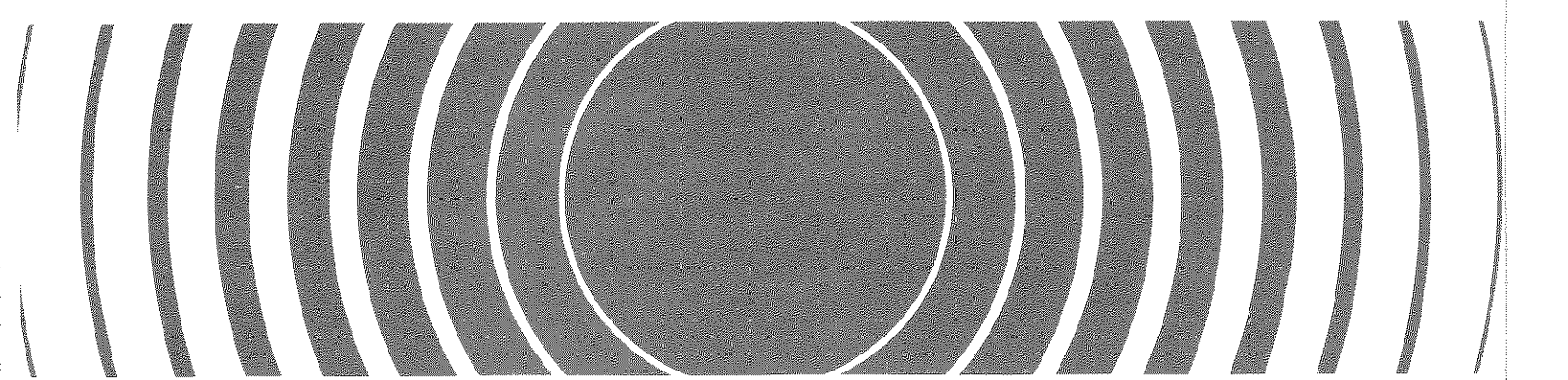

Final Rule for Radon - 222 Emissions from Licensed Uranium Mill Tailings

Background Information Document



40 CFR Part 61
National Emission Standards
for Harzardous Air Pollutants

EPA 520/1-86-009

BACKGROUND INFORMATION DOCUMENT
STANDARD FOR RADON-222 EMISSIONS
FROM LICENSED URANIUM MILL TAILINGS

August 15, 1986

U.S. Environmental Protection Agency
Office of Radiation Programs
Washington, D.C. 20460

CONTENTS

	<u>Page</u>
Figures	vi
Tables	viii
1. INTRODUCTION	1-1
1.1 History of Standard Development	1-1
1.2 Content	1-3
1.3 Other EPA Standards Affecting Uranium Mills	1-3
1.4 Other Regulations Affecting Uranium Mills	1-5
2. ESTIMATING THE RISK DUE TO EXPOSURE TO RADON-222 DECAY PRODUCTS	2-1
2.1 Introduction	2-1
2.2 Radon-222 Exposure Pathways	2-2
2.2.1 Physical Considerations	2-2
2.2.2 Characterizing Exposures to the General Population Vis-a-vis Underground Miners	2-5
2.3 Health Risk From Exposure to Radon-222 Decay Products	2-7
2.3.1 Risk Models	2-7
2.3.2 The EPA Relative Risk Model	2-10
2.3.3 Comparison of Risk Estimates	2-12
2.3.4 Selection of Risk Coefficients	2-17
2.4 Estimating the Risks	2-18
2.4.1 Exposure	2-18
2.4.2 Risk Estimation	2-19
References	2-24
3. RADON-222 SOURCES, ENVIRONMENTAL TRANSPORT, AND RISK ESTIMATES	3-1
3.1 Introduction	3-1
3.2 Origin and Properties of Radon-222	3-1
3.3 Sources of Radon-222 Emissions in the Milling Process	3-4
3.4 Characterization of Emissions	3-14
3.4.1 Ore Handling and Preparation	3-18
3.4.2 Mill Emissions	3-19
3.4.3 Emissions From Tailings Disposal	3-20
3.5 Transport and Risk Assessment	3-21
3.5.1 Air Dispersion Estimates	3-22
3.5.2 Risk Estimates	3-22

CONTENTS (continued)

	<u>Page</u>
3.6 Measurement of Radon-222	3-22
3.6.1 Ambient Air Samplers	3-23
3.6.2 Concentrating Samplers That Measure Radon-222 Emanation From Surfaces	3-23
References	3-25
 4. INDUSTRY DESCRIPTION	 4-1
4.1 Overview	4-1
4.2 Site-Specific Characteristics	4-1
4.2.1 Colorado	4-5
4.2.2 New Mexico	4-12
4.2.3 Texas	4-19
4.2.4 Utah	4-22
4.2.5 Washington	4-25
4.2.6 Wyoming	4-28
4.3 Population Within 5 km (3.1 mi) of Existing Tailings Impoundments	4-35
References	4-38
 5. INDUSTRY RADON-222 EMISSION ESTIMATES	 5-1
5.1 Introduction	5-1
5.2 Estimating Emissions	5-1
References	5-7
 6. BASELINE INDUSTRY RISK ASSESSMENT	 6-1
6.1 Introduction	6-1
6.2 Risk Estimates	6-1
6.2.1 Nearby Individuals	6-1
6.2.2 Regional Population	6-2
6.2.3 National	6-6
6.2.4 Risks from New Tailings Impoundments	6-8
References	6-10
 7. RADON-222 CONTROL TECHNIQUES	 7-1
7.1 Description of Control Practices	7-1
7.1.1 Earth Covers	7-2
7.1.2 Water Cover	7-7
7.1.3 Water Spraying	7-9
7.1.4 Other Control Techniques	7-11

CONTENTS (continued)

	<u>Page</u>
7.2 Control Practices Applicable to Existing Tailings Impoundments	7-14
7.2.1 Interim Controls	7-14
7.2.2 Final Reclamation	7-16
7.2.3 Comparison of Interim and Final Controls	7-16
7.3 Control Practices Applicable to New Tailings Impoundments	7-18
7.3.1 Single Cell Tailings Impoundment	7-18
7.3.2 Phased Disposal Tailings Impoundment	7-24
7.3.3 Continuous Disposal	7-30
7.4 Summary of Radon-222 Control Practices	7-38
References	7-41
8. SUMMARY AND COMPARISON OF WORK PRACTICES	8-1
8.1 Single-Cell Impoundments	8-1
8.2 Phased Disposal	8-3
8.3 Continuous Disposal	8-7
8.4 Comparison of Work Practices	8-7
Appendices	
A - Diagrams of Uranium Mill Sites and Tailings Impoundments	A-1
B - Cost Estimates for Existing and Model New Uranium Mill Tailings Impoundments	B-1
C - Evaluation of Interim Cover as a Control Option	C-1

FIGURES

Number		Page
2-1	Radon-222 decay series	2-3
2-2	U.S. lung cancer mortality by age--1970	2-9
3-1	Uranium-238 decay chain and half-lives of principal radionuclides	3-2
3-2	Schematic illustration of the radon sources at a uranium mill	3-5
3-3	Simplified flow diagram of the acid leach process	3-10
3-4	Simplified flow diagram of the alkaline leach-caustic precipitation process	3-11
3-5	Qualitative illustration of radon-222 emissions from licensed uranium milling process	3-15
3-6	Effect of ore pile depth on hyperbolic tangent term in radon-222 flux equation	3-17
4-1	Approximate locations of licensed conventional uranium mills	4-4
4-2	Location of mills in Colorado	4-10
4-3	Location of mills in New Mexico	4-14
4-4	Location of mills in Texas	4-21
4-5	Location of mills in Utah	4-23
4-6	Location of mills in Washington	4-26
4-7	Location of mills in Wyoming	4-29
7-1	Changes in radon-222 penetration with earth cover thickness	7-4
7-2	Radon emanation coefficients for tailings samples	7-10
7-3	Size and layout of the model single cell tailings impoundment	7-20
7-4	Estimated radon-222 emissions from a model single-cell tailings impoundment	7-21

FIGURES (continued)

Number		Page
7-5	Size and layout of model phased-disposal impoundment	7-26
7-6	Estimated radon-222 emissions from a model phased-disposal impoundment	7-27
7-7	Size and layout of the model continuous-disposal impoundment	7-32
7-8	Estimated radon-222 emissions from a model continuous-disposal impoundment	7-35
7-9	Estimated radon-222 emissions from a model continuous single-cell disposal impoundment	7-36

TABLES

Number		Page
2-1	Annual exposure equivalent (WLM) as a function of age for members of the general public continuously exposed to radon progeny	2-7
2-2	Age-dependent risk coefficients and minimum induction period for lung cancer due to inhaling radon-222 progeny	2-12
2-3	Estimated risk from exposure to radon-222 progeny	2-15
2-4	Radon-222 decay product equilibrium fraction at selected distances from the center of a tailings impoundment	2-20
2-5	Lifetime risk for lifetime exposure to a given level of radon-222 progeny	2-22
3-1	Properties of radon-222	3-3
4-1	Operating status and capacity of licensed conventional uranium mills as of August 4, 1986	4-2
4-2	Summary of current uranium mill tailings impoundment areas and radium-226 content	4-6
4-3	Estimate of the population living within 0 to 5 km from the centroid of tailings impoundments of active and standby mills in 1983	4-36
4-4	Estimate of the population living within 0 to 5 km from the centroid of tailings impoundments of active and standby mills in 1985	4-37
5-1	Summary of radon-222 emissions from uranium mill tailings impoundments	5-3
6-1	Estimated risk of fatal lung cancer from maximum exposure for an individual living near tailings impoundment	6-3
6-2	AIRDOS-EPA code inputs and estimated risks	6-4
6-3	Summary of regional health effects from existing tailings impoundments	6-5

TABLES (continued)

Number		Page
6-4	Summary of nationwide health effects for tailings impoundments	6-7
6-5	Summary of fatal cancers from current tailings impoundments	6-9
7-1	Percent reduction in radon-222 emissions attained by applying various types of earth cover	7-5
7-2	Summary of unit costs for estimating earth cover costs	7-6
7-3	Earth moving and placement costs (thousands of dollars per hectare) of attenuating radon-222 as a function of thickness (meters of different soils) and type of earth	7-8
7-4	Benefits and Cost of alternatives that apply earth cover to existing tailings impoundments	7-17
7-5	Average radon-222 emission rate from model single-cell tailings impoundments	7-22
7-6	Estimated costs for a model single-cell tailings impoundment	7-23
7-7	Average radon-222 emission rate for model single-cell and phased-disposal tailings impoundments	7-28
7-8	Estimated costs for a model phased-disposal impoundment	7-33
7-9	Estimated radon-222 emission rates for model single-cell, phased-disposal, and continuous-disposal tailings impoundments	7-34
7-10	Estimated costs for a model continuous-disposal impoundment	7-37
7-11	Summary of estimated radon-222 emissions from new model tailings impoundments	7-39
7-12	Summary of estimated costs for new model tailings impoundment	7-40

TABLES (continued)

Number		Page
8-1	Emission and cost comparison for single cell impoundment with final cover applied at 0, 20, and 40 years after reaching capacity	8-2
8-2	Comparison of estimated deaths and benefits for a single cell model impoundment with final cover applied at 0, 20, and 40 years after reaching capacity	8-4
8-3	Emissions and costs for model phased-disposal impoundments	8-5
8-4	Comparison of estimated death for model phased-disposal impoundments	8-6
8-5	Emissions and cost of model below-grade trench type continuous disposal impoundment	8-8
8-6	Comparison of work practices for new model tailings impoundments	8-9
8-7	Comparison of cost and benefits between model Base Case I and new work practices	8-11
8-8	Comparison of cost and benefits between model Base Case II and new work practices	8-12

Chapter 1: INTRODUCTION

This Background Information Document supports the Agency's final rule on radon-222 emissions from licensed uranium milling activities. It is an integrated risk assessment that provides the scientific basis for this action. Although the U.S. Environmental Protection Agency (EPA) has considered radon-222 in several regulatory actions, no specific emission standard for this radionuclide has yet been promulgated for operating licensed uranium mills.

1.1 History of Standard Development

On January 13, 1977 (42 FR 2858), EPA issued Environmental Radiation Protection Standards for Nuclear Power Operations. These standards, promulgated in Title 40, Code of Federal Regulations Part 190 (40 CFR 190), limit the total individual radiation dose due to emissions from uranium fuel-cycle facilities, including licensed uranium mills. At the time 40 CFR 190 was promulgated, considerable uncertainty existed regarding the public health impact of levels of radon-222 in the air and the best method for managing new man-made sources of this radionuclide. Therefore, the Agency exempted radon-222 from control under 40 CFR 190.

On September 30, 1983, the Agency issued standards under the Uranium Mill Tailings Radiation Control Act (UMTRCA) (40 CFR 192, Subparts D and E) for the management of tailings at locations licensed by the Nuclear Regulatory Commission (NRC) or the States under Title II of the UMTRCA. These standards do not specifically limit radon-222 emissions until after closure of a facility; however, they require as low as reasonably achievable (ALARA) procedures for radon-222 control, and the NRC does consider ALARA procedures in licensing a mill. When the UMTRCA standards were promulgated, the Agency stated that it would issue an Advance Notice of Proposed Rulemaking with respect to control of radon-222 emissions from uranium tailings piles during the operational period of a uranium mill.

On April 6, 1983, standards for NRC licensees were proposed under the Clean Air Act (48 FR 15076, April 6, 1983); however, uranium fuel-cycle facilities, which included operating uranium mills, were excluded because these sources are subject to EPA's 40 CFR Part 190 standard.

During the comment period for the Clean Air Act standards, it was noted that radon-222 emitted from operating uranium mills and their actively used tailings piles were not subject to any current or proposed EPA standards, and that such emissions could pose significant risks.

On October 31, 1984, EPA published an Advance Notice of Proposed Rulemaking in the Federal Register, 49 FR 43916, for radon-222 emissions from licensed uranium mills. The notice stated that the Agency is considering emissions standards for licensed uranium mills and solicited information in the following areas:

- o Radon-222 emission rates from uranium mills and associated tailings piles
- o Local and regional impacts due to emissions of radon-222 from uranium mills and associated tailings piles prior to permanent disposal
- o Applicable radon-222 control options and strategies, including work practices
- o Feasibility and cost of radon-222 control options and strategies
- o Methods of determining compliance with a work practice type of standard to control radon-222 emissions
- o Impact of radon-222 controls on the uranium industry

Pursuant to the citizens' suit provision of the Act, the U.S. District Court for the Northern District of California directed EPA to promulgate standards for other sources of radionuclide emissions, which could include radon-222 emissions from licensed uranium mills. Thus, discussions between EPA and the Sierra Club regarding a schedule for developing a standard led to an agreement to submit a schedule for the promulgation of a standard in one year rather than having the Court establish a schedule. This motion was submitted to the Court on August 5, 1985, and the Court ordered the EPA to issue final standards for radon-222 emissions from licensed uranium mills and mill tailings impoundments by May 1, 1986. This date was later moved to August 15, 1986 to allow additional time for public comment.

The EPA then issued the proposed rulemaking for "National Emission Standards for Hazardous Air Pollutants; Standards for Radon-222 Emissions from Licensed Uranium Mill Tailings," on February 21, 1986 (51 FR 6382-6387). Subsequent to the announcement of the proposed rule, a public hearing was held on March 25, 1986 in Denver, Colorado (51 FR 8205) and a second comment period was held open until April 28, 1986.

1.2 Content

The health effects of radon-222 and the risk assessment procedure are summarized in Chapter 2. The incidence of lung cancer and resulting deaths among miners exposed to radon-222 are described, and the range of risk factors is presented.

The sources of radon-222 in uranium milling and the factors affecting the rate of radon-222 emissions are described in Chapter 3. This chapter also includes a general description of EPA's risk-estimating procedure, along with the methods of measuring radon-222.

A description of each licensed mill, its associated tailings impoundments, and its estimated milling production rates are contained in Chapter 4. Estimates of radon-222 emissions from the existing tailings impoundments are presented in Chapter 5.

The baseline industry risk assessment for individuals and regional and national populations and the control techniques and work practices that can be used to reduce radon-222 emissions are described in Chapters 6 and 7 respectively. The resulting emissions after application of these control methods are estimated. A comparison of work practices, costs, and effectiveness is presented in Chapter 8.

Information for this study was compiled from the technical literature, previous studies by EPA and the Nuclear Regulatory Commission, comments resulting from rulemaking notices, and discussions with industry representatives. Comments received during the public comment period were incorporated into this final document as appropriate. No significant change in the technical information was made except for the Agency's revision of the risk factors associated with radon-222 exposure. These risk factors were increased from a range of 250-1000 deaths per million person working level months to a range of 380-1520 deaths per million person working level month. In addition, mill site-specific information was corrected and the discussion of interim cover was revised.

1.3 Other EPA Standards Affecting Uranium Mills

On December 3, 1982, EPA issued guidelines under the Clean Water Act for effluent limitations for New Source Performance Standards for wastewater discharges from the mining and dressing of uranium, radium, and vanadium ores (40 CFR Part 440, 47 FR 54598). These effluent guidelines cover discharges of both radioactive and nonradioactive materials to surface waters from uranium byproduct materials.

The EPA promulgated 40 CFR Part 261, Subpart F --Groundwater Protection--on July 26, 1982 (47 FR 32274) under the Solid Waste Disposal Act (SWDA) as amended by the Resource Recovery and Conservation Act. This Act requires that standards for nonradioactive hazards from uranium byproduct materials be consistent with standards promulgated under SWDA for such hazards. The Act also requires that the NRC establish general requirements that are, insofar as possible, at least comparable to requirements applying to the possession, transfer, and disposal of similar hazardous material regulated by EPA under the SWDA.

The EPA issued standards for cleanup of contaminated open lands and buildings and for disposal of tailings at inactive uranium processing sites on January 5, 1983 (48 FR 590) under UMTRCA. For inactive mills, the standard specified in 40 CFR 192.02 requires that controls:

- "(a) Be effective for up to one thousand years, to the extent reasonably achievable, and, in any case, for at least 200 years, and,
- (b) Provide reasonable assurance that releases of radon-222 from residual radioactive material to the atmosphere will not:
 - (1) Exceed an average release rate of 20 picocuries per square meter per second, or
 - (2) Increase the annual average concentration of radon-222 in air at or above any location outside the disposal site by more than one-half picocurie per liter."

This standard was later amended under Section 84 of the Atomic Energy Act of 1954 to include standards for radionuclides during and after processing of uranium ore sites (48 FR 45946, October 7, 1983). These regulations in 40 CFR 192.30 specify concentration limits and construction standards for surface impoundments to ensure ground-water protection. In addition, Part 192.32 addresses radon-222 at active mills in a generic manner by requiring the mill owner to "make every effort to maintain radiation doses from radon-222 emissions from surface impoundments of uranium byproduct materials as far below the Federal Radiation Protection Guides as is practicable at each licensed site."

This standard also specifies that radon-222 emissions are limited to 20 picocuries per square meter per second (pCi/m s) after mill closure. This limitation does not apply to sites that contain a radium-226 concentration from mill tailings that does not exceed the background level by more than 5 pCi per gram over the top 15 cm of soil and 15 pCi per gram over each successive 15-cm layer of soil below the top 15 cm.

1.4 Other Regulations Affecting Uranium Mills

All uranium mills are licensed by the NRC or by States that enforce the NRC regulations, and are subject to the regulations contained in 10 CFR 20. Specific standards pertaining to radon-222 limit atmospheric radon-222 concentrations to 3×10^{-8} pCi/ml (30 pCi/liter) in restricted areas (i.e., areas within the mill property) and 3×10^{-9} pCi/ml (3 pCi/liter) in unrestricted areas. These concentrations are approximately equivalent to one-third and one-thirtieth of a working level, (a) respectively. The NRC has also recently issued amendments to its regulations governing uranium mill tailings disposal (100 CFR Part 40) as published on October 16, 1985 (50 FR 41852). These amendments conform to the EPA regulations for tailings disposal.

The NRC has entered into agreement with a number of States to provide enforcement of the NRC regulations. These States are referred to as "Agreement States." The Agreement States that have uranium mills are Colorado, New Mexico, Texas, and Washington (b).

State regulations pertain to the construction of tailings impoundments to minimize ground-water contamination. In addition, States inspect tailing impoundment dams to ensure that they are built and maintained to minimize safety problems.

- (a) A working level is defined in Chapter 2. The relationship between radon-222 and working levels depends on the degree of equilibrium between radon-222 and its decay products.
- (b) Utah also is an Agreement State in nuclear licensing areas other than uranium milling. New Mexico returned licensing authority to the NRC on May 1, 1986.

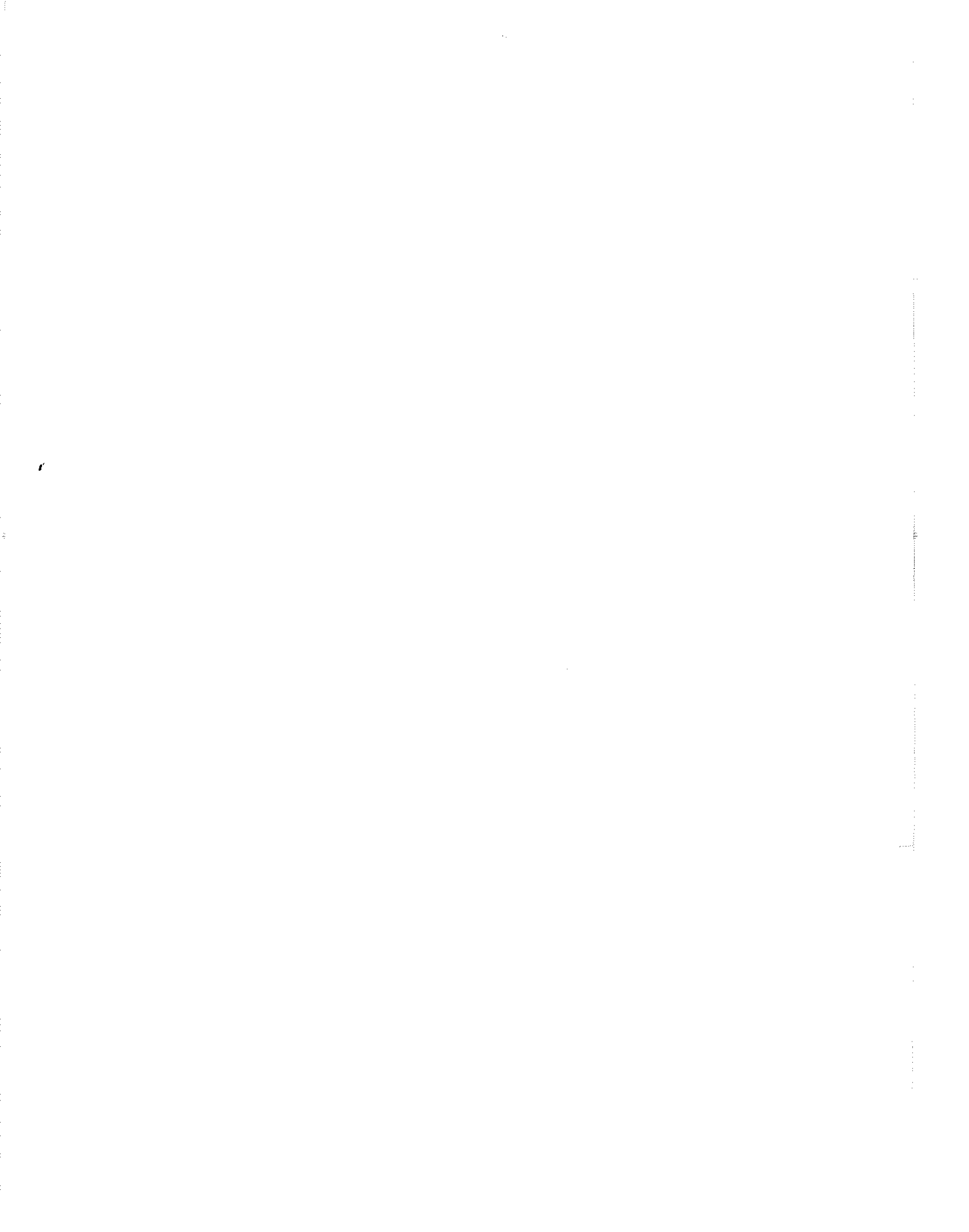

Chapter 2: ESTIMATING THE RISK DUE TO EXPOSURE TO RADON-222 DECAY PRODUCTS

2.1 Introduction

The methodology the EPA uses to estimate the exposure and the health detriment (i.e., lung cancer) due to radon-222 in the general environment is described in this chapter. Radon-222 exposure pathways are explained, the EPA risk model is described, estimates of risks due to radon-222 progeny (radon-222 decay products) made by various scientific groups are compared, and the risk coefficients to be used in this risk assessment are selected. Earlier studies have shown that a degree of uncertainty exists in all risk estimates (EPA84); therefore, EPA uses more than a single coefficient to indicate the range of this uncertainty.

The occurrence of radiation-induced cancer is infrequent compared with the current incidence of all cancers. Even among heavily irradiated populations (e.g., some of the uranium mine workers in epidemiologic studies), the precision and accuracy of the estimate of the number of lung cancers resulting from radiation is uncertain because of the small sampling segment and because the data vary greatly. Also, the small sampling of exposed populations has not been followed for their full lifetime; therefore, information on the ultimate effects of their exposure is limited.

Only human epidemiological data are used to derive risk estimates for effects of exposure to radon-222 progeny, but animal studies support the risk estimates. In a series of studies performed with rats, French investigators have shown a dose-effect relationship similar to that obtained in surveys of uranium miners (Ch84, 85). In these studies, the risk per working level month at 20 cumulative working level months (CWLM) is about four times greater than at 3000 or more CWLM (Ch84, 85). The lowest exposure studied to date, 20 CWLM, which is about 10 times the background exposure, doubled the incidence of lung cancer in the rats (Ch84, 85).

When considered in light of experiments with animals and various theories of carcinogenesis and mutagenesis, the observational data on cancers related to human exposure to radiation are subject to a number of interpretations. These various interpretations lead to differing estimates of radiation risks by both individual radiation scientists and expert advisory groups. Readers should bear in mind that estimating radiation risks is not a mature science and that the evaluation of the risk due to radon-222 decay products (progeny) will change as additional information becomes available.

Nevertheless, a substantial data base is available for use in developing risk estimates, and the Agency believes these estimates can be used in the development of regulatory requirements.

2.2 Radon-222 Exposure Pathways

2.2.1 Physical Considerations

Radon-222 from uranium milling operations enters the general environment from stockpiled ore and mill exhaust systems and through waste materials from milling operations. The half-life of radon-222 is 3.8 days; therefore, when it is released into the atmosphere, some atoms of gaseous radon-222 can travel thousands of miles through the atmosphere before they decay. As shown in Figure 2-1, the radon-222 decay process involves seven principal decay products before the radon-222 becomes nonradioactive lead. The first four short-half-life radioactive decay products of radon-222 are the most important sources of cancer risk. Members of the decay chain with relatively long half-lives (beginning with lead-210, which has a 22-year half-life) are more likely to be ingested than inhaled and generally present much smaller risks.

The principal short-half-life products of radon-222 are polonium-218, lead-214, bismuth-214, and polonium-214. Polonium-218, the first decay product, has a half-life of just over 3 minutes. This is long enough for most of the electrically charged polonium atoms to attach themselves to microscopic airborne dust particles that are typically less than a millionth of a meter in diameter. When inhaled, these small particles have a good chance of sticking to the moist epithelial lining of the bronchi. Most inhaled particles are eventually cleared (removed) from the bronchi by mucus, but not quickly enough to keep the bronchial epithelium from being exposed to alpha particles from the decay of polonium-218 and polonium-214. This highly ionizing radiation passes through and delivers radiation doses to several types of lung cells.

Adequate characterization cannot be made of the exact doses delivered to cells that eventually become cancerous. Knowledge of the deposition pattern of the radioactive particles in the lung is based on theoretical models, and the distances from the radioactive particles to cells that are susceptible can only be assumed. Further, some disagreement exists about the types of bronchial cells in which cancer originates. Therefore, EPA estimates of lung cancer risk are based on the amount of inhaled radon-222 decay products to which people are exposed rather than on the dose absorbed by the lung.

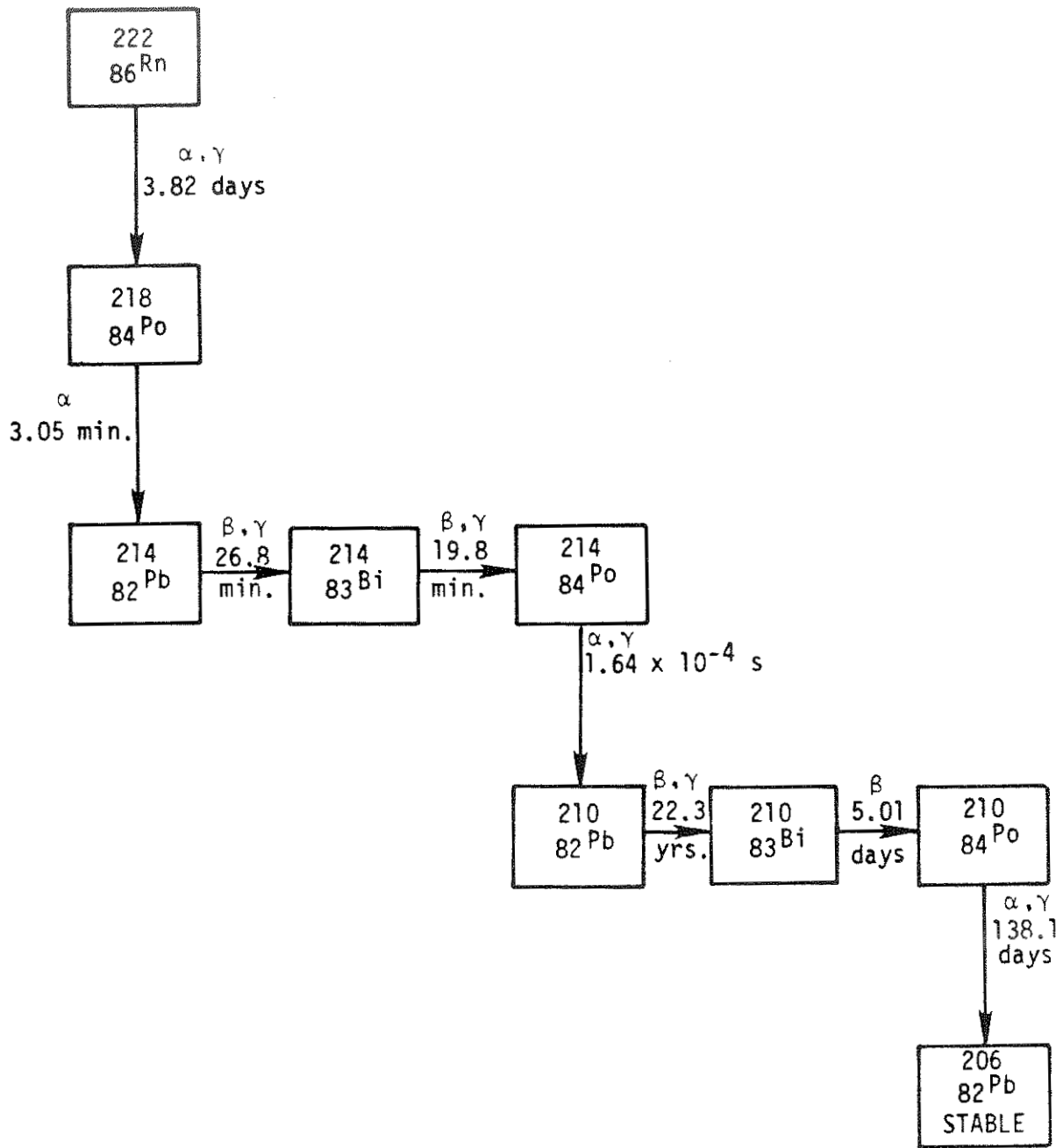

Figure 2-1. Radon-222 decay series.

Ingrowth of Radon-222 Decay Products

At the point where radon-222 diffuses out of the tailings pile surface, the concentration of associated radon-222 decay products is zero because those decay products generated prior to diffusion from the surface have been captured in the tailings or cover. As soon as radon-222 is airborne, ingrowth of decay products commences and secular equilibrium between the radon-222 and the short half-life decay products is eventually obtained. At secular equilibrium, the activities of radon-222 and of all its short-half-life decay products are equal, and the alpha activity per unit of radon-222 concentration is at its maximum. As a means of accounting for the incomplete equilibrium before this state is reached, the "equilibrium fraction" is defined as the ratio of the potential alpha energy from those decay products actually present to the potential alpha energy that would be present at complete equilibrium. As radon-222 and its decay products are transported by the wind, the equilibrium fraction increases with distance from the tailings pile, and at great distances, approaches the theoretical maximum value of one; however, depletion processes, such as dry deposition and precipitation scavenging, selectively remove decay products (but not radon), so complete equilibrium of the short-lived decay products with the radon-222 is seldom, if ever, reached.

When radon-222 and its decay products enter a structure, the building ventilation rate is the principal factor affecting the indoor equilibrium fraction. The equilibrium fraction can also be affected by other considerations, however, such as the indoor surface-to-volume ratio and the dust loading in indoor air (Po78).

In estimating the exposures of nearby individuals to radon-222 decay products (in Chapter 6), the model uses the calculated effective equilibrium fraction at selected distances from a tailings pile (see Table 2-4 presented later in this chapter). For estimating population exposures, a population-distance weighted effective equilibrium fraction would be appropriate, but it is impractical to calculate this fraction. Indoor exposure is the dominant form of exposure due to radon-222 [Americans spend about 75 percent of their time indoors (Mo76, Oa72)], and the indoor effective equilibrium fraction does not depend greatly on the distance from the tailings pile. In this assessment, an effective equilibrium fraction of 70 percent is assumed for calculating the exposure of populations because most of the affected individuals are at some distance from the tailings pile (see Section 2.4.1).

2.2.2 Characterizing Exposures to the General Population Vis-a-vis Underground Miners

Although considerable progress has been made in modeling the deposition of particulate material in the lung (Ha82, Ja80, Ja81), adequate characterization of the bronchial dose delivered by alpha particles from inhaled radon-222 progeny attached to dust particles is not yet possible. Knowledge is still lacking concerning the kinds of cells in which bronchial cancer is initiated (Mc78, Mc83) and the depth of these cells in the bronchial epithelium. Current estimates of the exposure dose of inhaled radon-222 progeny actually causing radiogenic cancer are based on average doses, which may or may not be relevant (E185). Until more reliable estimates of the bronchial dose become available, following the precedents set in the 1972 and 1980 National Academy of Sciences reports appears to be a prudent approach (NAS72, NAS80). Therefore, the EPA estimates the risk due to radon-222 progeny on the basis of exposure rather than dose per se. This is called the epidemiological approach; i.e., risk is estimated on the basis of observed cancers after occupational exposure to radon-222 progeny.

Exposures to radon-222 decay products under working conditions are commonly reported in a special unit called the working level (WL). One working level is any concentration of short half-life radon-222 progeny having 1.3×10^5 MeV per liter of potential alpha energy (FRC67). (A WL is also equivalent to approximately 100 pCi/liter of radon-222 in secular equilibrium with its short-lived decay products.) This unit was developed because the concentration of specific radon-222 progeny depends on ventilation rates and other factors. A working level month (WLM) is the unit used to characterize a mine worker's exposure to one working level of radon-222 progeny for a working month of 170 hours. Inasmuch as the results of epidemiological studies are expressed in units of WL and WLM, comparable estimates of exposure were developed for members of the general population exposed to radon-222 progeny, as explained in the following paragraphs.

For a given concentration of radon-222 progeny, the amount of potential alpha energy a member of the general population inhales in a month is more than the amount a mine worker receives in a working month. Although members of the general population are exposed longer (up to 24 hours per day, 7 days a week), the average amount of air inhaled per minute (minute volume) is less in this group than that for a mine worker when periods of

sleeping and resting are taken into account (EPA79, Th82). The radon-222 progeny exposure of a mine worker can be compared with that of a member of the general population by considering the amount of potential alpha energy each inhales per year (Ev69). That radon daughter deposition (and dose) in the conducting airways of the lung is proportional to ventilation rate (quantity inhaled) has also been recommended by other investigators (Ra85, Ho82).

The EPA assumes that a mine worker inhales 30 liters per minute (averaged over a work day). This average corresponds to about 4 hours of light activity and 4 hours of moderately heavy work per day (ICRP75). The new ICRP radon-222 model, however, assumes an inhalation rate of 20 liters per minute for mine workers, which corresponds to 8 hours of light activity per day (ICRP81). This may be appropriate for nuclear workers; however, studies of the metabolic rate of mine workers clearly show that they are not engaged in light activity only (Sp56, ICRP75, NASA73). Therefore, 30 liters appears to be a more realistic estimate of the average minute volume for this group. Based on this minute volume, a mine worker inhales 3.6×10^3 cubic meters in a working year of 2000 hours (ICRP79). One working level of radon-222 progeny is 2.08×10^{-5} joules per cubic meter (1.3×10^{-5} MeV per liter); therefore, in a working year, the potential alpha energy inhaled by a mine worker exposed to one working level is 7.5×10^{-2} joules.

According to the ICRP Task Group report on reference man (ICRP75), an inhaled air volume of 2.3×10^4 liters per day is assumed for adult males in the general population and 2.1×10^4 liters per day for adult females, or an average of 2.2×10^4 liters per day for members of the adult population. This average volume results in an intake of 8.04×10^3 cubic meters of air and 1.67×10^{-1} joules per year of inhaled potential alpha energy from a continuous exposure of an adult member of the population to one working level of radon-222 progeny for 365.25 days.

Although it may be technically inappropriate to quantify the amount of potential alpha particle energy inhaled by a member of the general population in working level months, continuous exposure to 1 WL corresponds to about the same inhaled potential alpha energy as 27 WLM would to a miner. Hence, for an adult member of the general population, a one working level concentration of radon progeny results in a 27 WLM annual exposure equivalent (see Table 2-1). As stated earlier, an occupancy factor of 0.75 is assumed for indoor exposure; thus, an indoor exposure to one WL results in an annual exposure equivalent of 20 WLM (EPA79) in terms of the amount of potential alpha energy actually inhaled.

The smaller bronchial area of children as compared with that of adults more than offsets their lower per-minute volume; therefore, for a given concentration of radon-222 progeny, the dose to children's bronchi is greater. This problem has been addressed in a paper by Hofmann and Steinhausler (Ho77), in which they estimate that doses received during childhood are about 50 percent greater than adult doses. This information was used to prepare Table 2-1, which lists the age-dependent potential exposure equivalent used in the risk assessment described in the next subsection.^(a) The larger effective exposure to children relative to that to adults increases the estimated mortality due to lifetime exposure from birth by about 20 percent.

Table 2-1. Annual exposure equivalent (WLM) as a function of age for members of the general public continuously exposed to radon progeny at one working level (2.08×10^{-5} joules per cubic meter)

Age of general population (years)	Exposure Equivalent (WLM)
0-2	35
3-5	43
6-11	49
12-15	43
16-19	38
20-22	32
23 or more	27
Lifetime Average	31

2.3 Health Risk From Exposure to Radon-222 Decay Products

2.3.1 Risk Models

A wealth of data indicates that radon-222 exposure of the bronchial epithelium of underground mine workers causes an increase in bronchial lung cancer among both smokers and nonsmokers. Among recent reviews (ICRP81, NA580, NCRP84, N105H85, Th82), two are of particular interest.

(a) The assumptions on minute volume, etc., for mine workers and the general population just described are the same as those used in the preparation of the EPA report entitled "Indoor Radiation Exposure Due to Radium-226 in Florida Phosphate Lands" (EPA79) and Final Environmental Impact Statements (EPA82, 83a).

The 1980 NAS BEIR-3 Report (NAS80) contains a review of epidemiological studies on mine workers and develops an age specific absolute risk model. A lengthy report entitled "Risk Estimates for the Health Effects of Alpha Radiation," which was prepared by D. C. Thomas and K. C. McNeil for the Atomic Energy Control Board (AECB) of Canada, reanalyzes many of these epidemiological studies in a consistent fashion so that the modeling assumptions are the same for all of the data sets and develops a relative risk coefficient which fits most studies (Th82).

The manner in which radiogenic lung cancers are distributed in time, after a minimum induction period, is a crucial factor in numerical risk estimates. For radiation-induced leukemia and bone cancer, the period of risk expression is relatively brief; most occur within 25 years of exposure. For other radiation-induced cancers (including lung cancer), however, it appears that people are at risk for the remainder of their lives (NAS80). None of the epidemiological studies of underground mine workers provides information on lifetime expression; indeed, most of the study populations are still alive and still at risk. Lifetime risks cannot be estimated only on the basis of observations to date; therefore, a model is needed to project the risk beyond the period of direct observation. As discussed in the 1980 NAS BEIR report, there are two basic models of risk projection: (1) the absolute risk projection model, in which it is assumed that the observed annual numerical excess cancer risk per unit exposure (or dose) continues throughout life; and (2) the relative risk projection model, in which it is assumed that the observed percent age increase of the baseline cancer risk per unit exposure (or dose) is constant with time (NAS80).

In the case of lung cancer and most other solid cancers, a relative risk model leads to larger estimated risks than the absolute risk model because of the generally increasing incidence of such cancers with increasing age. The number of lung cancer deaths that occurred in the U.S. population as a function of age in 1970 and in 1980 is shown in Figure 2-2. The decrease in the number of deaths for ages greater than 65 years is due in part to depletion of the population by competing risks, and in part to a decrease in the age-specific incidence of lung cancer mortality, which peaks in males at about age 75 but is relatively constant in females until age 95 (NCHS73, NCHS83) (see Figure 2-3). The age-specific mortality of underground mine workers dying of radiogenic lung cancer shows the same pattern of death as a function of age as the general male population (Ra84, E185). In a recent review (E185), it was shown that a relative risk model can adequately account for the temporal pattern of cancer deaths observed in underground mine workers, whereas absolute risk projection models fail to do so.

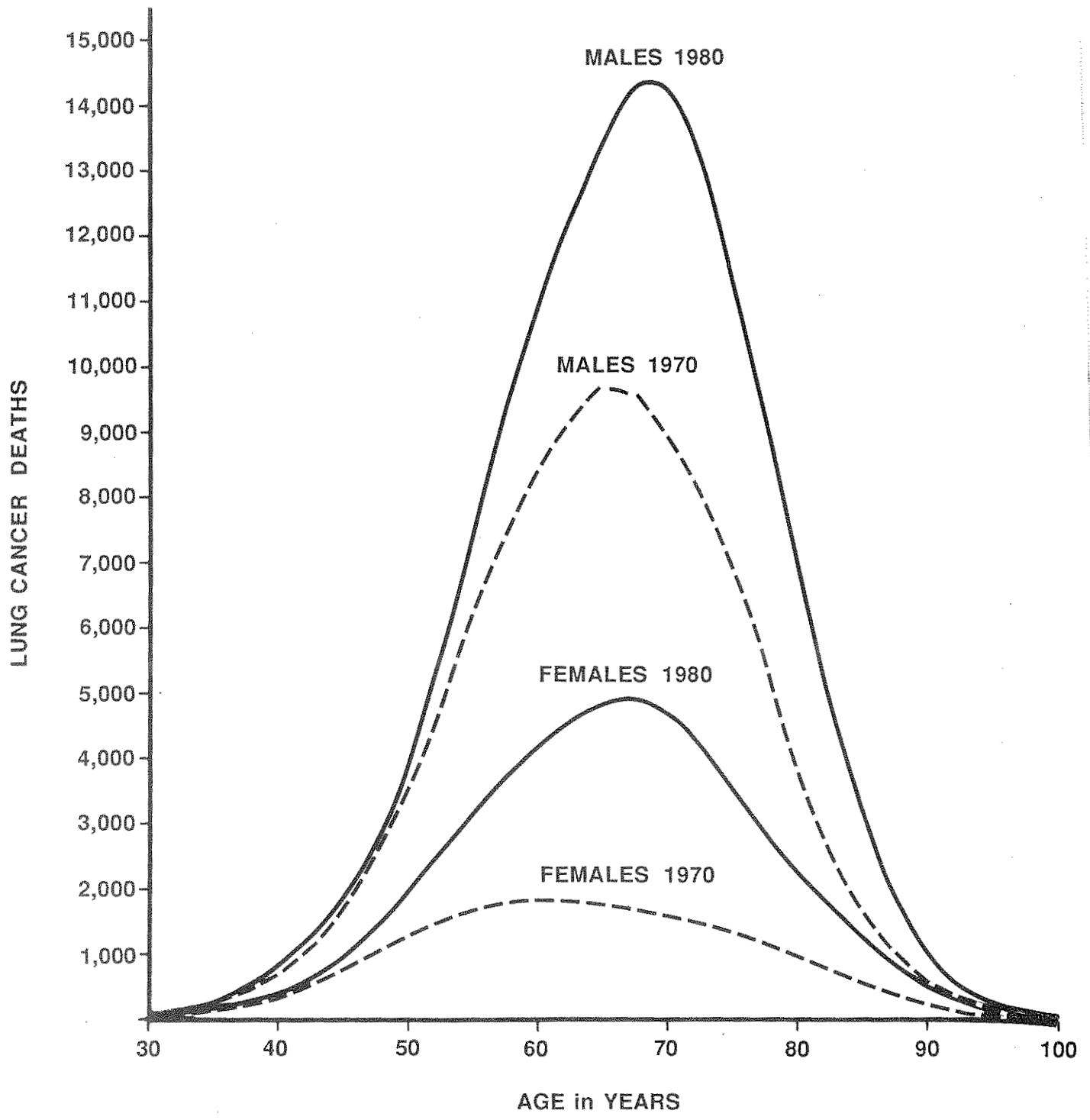

Figure 2-2. U.S. lung cancer mortality by age--1970 and 1980.

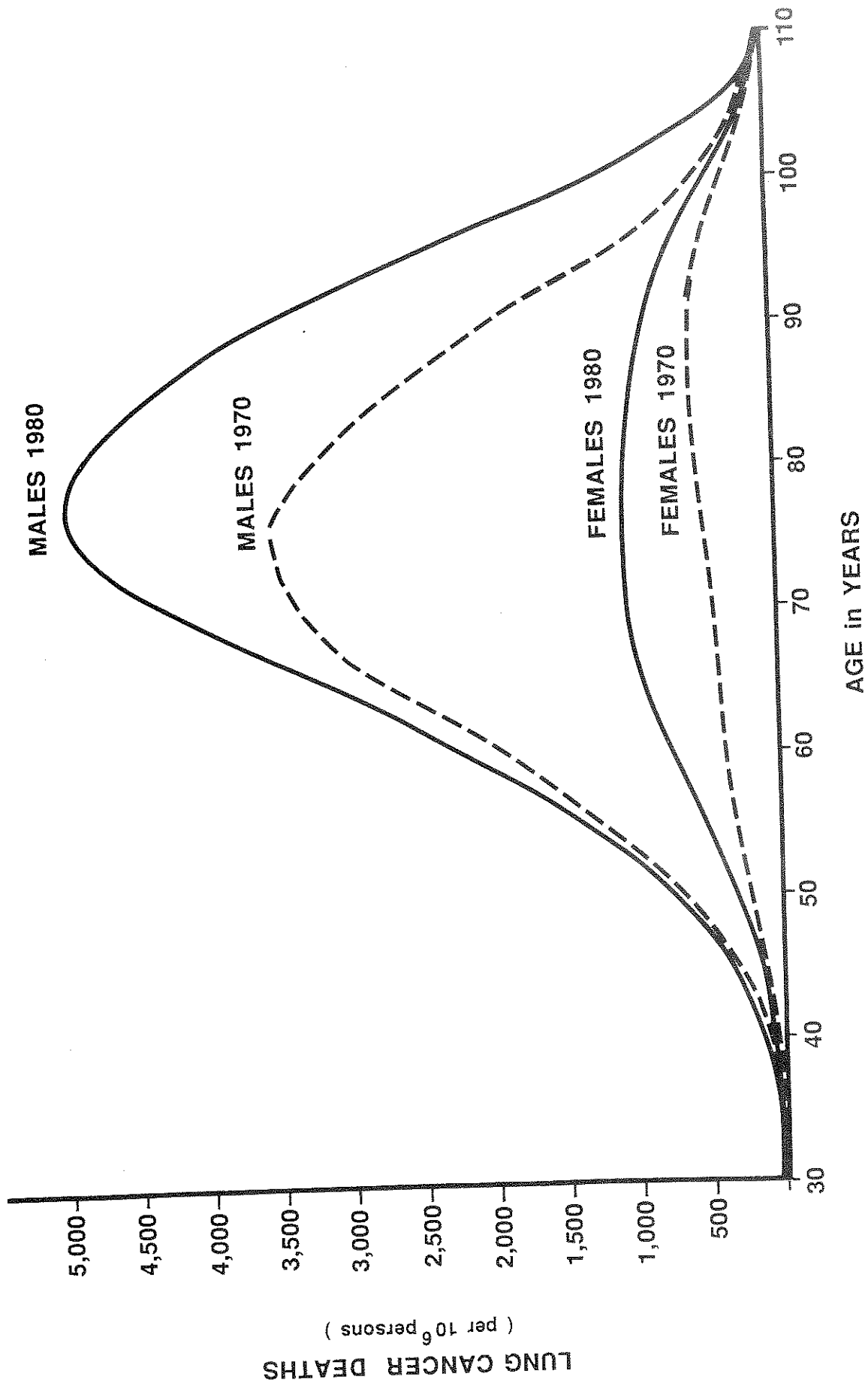

Figure 2-3. Age-specific U.S. lung cancer mortality rates--1970 and 1980

2.3.2 The EPA Relative Risk Model

Since 1978, the Agency has based risk estimates due to inhaled radon-222 progeny on a linear dose-response function, a relative risk projection model, and a minimum induction period of 10 years. Lifetime risks are projected on the assumption that exposure to 1 WLM increases the age-specific risk of lung cancer by 3 percent over the age-specific rate in the U.S. population as a whole (EPA79). The life table analysis described in Bu81 and EPA84 is used to project this risk over a full life span.

The EPA model has been described in detail (EPA79, E179). A review of this model in light of the more recent information described herein revealed that the major assumptions, linear response, and relative risk projection have been affirmed. The A-bomb survivor data clearly indicate that the absolute risk of radiogenic lung cancer has continued to increase among these survivors, whereas their relative risk has remained reasonably constant (Ka82). The UNSCEAR, the ICRP, and the 1980 NAS Committee have continued to use a linear dose response to estimate the risk of lung cancer due to inhaled radon-222 progeny. Thomas and McNeill's analysis (Th82) indicates that the use of linearity is not unduly conservative and actually may underestimate the risk at low doses. The 1980 NAS BEIR Committee reached a similar conclusion (NAS80).

A major limitation of earlier EPA risk estimates is the uncertainty in the relative risk coefficient used, 3 percent increase in the age-specific lung cancer mortality rate per WLM. This value is based on the excess mortality caused by lung cancer among exposed mine workers of various ages, many of whom smoked. Therefore, it represents an average value for a mixed population of smokers, former smokers, and nonsmokers. This assumption may tend to inflate the risk estimate (as discussed herein) because smoking was more prevalent among some groups of mine workers studied than it is among the U.S. general population today.

In a recent paper, Radford and Renard (Ra84) reported on the results of a long-term study of Swedish iron miners who were exposed to radon-222 progeny. This study is unique in that most of the miners were exposed to less than 100 WLM and the risks to smokers and nonsmokers were considered separately. The absolute risks of the two groups were similar, 20 fatalities per 10^6 person-year WLM for smokers compared with 16 fatalities for nonsmokers. The total number of lung cancer fatalities for nonsmokers is small; therefore, the estimate of 16 fatalities is not too reliable. Although absolute risks were comparable for

the smoking and nonsmoking miners, relative risks were not. Nonsmokers have a much lower baseline incidence of lung cancer mortality than smokers. This resulted in a relative risk coefficient for nonsmoking exposed miners relative to unexposed nonsmokers that was about four times larger than the relative risk coefficient for exposed smokers. This larger relative risk does not, however, fully compensate for the lower baseline incidence of lung cancer mortality among nonsmokers. Therefore, this study indicates that a relative risk coefficient derived from data on miners maybe biased high when applied to the population as a whole. Further follow-up of this and other groups of mine workers may provide more reliable data on the risk to nonsmokers, and EPA expects to incorporate separate consideration of smokers and nonsmokers into its analyses as more data become available.

Although occupational exposures to pollutants other than radon-222 progeny are probably not important factors in the observed lung cancer risk for underground mine workers (E179, Th82, Mu83, Ra84), the use of occupational risk data to estimate the risk of a general population is far from optimal, as it provides no information on the effect of radon-222 progeny exposures to children and women. Although the assumption has continued that the risk per unit exposure during childhood is no more effective than that occurring to adults, this assumption may not be correct. The A-bomb survivor data indicate that, in general, the risk resulting from childhood exposure to low linear energy transfer (LET) radiation is greater than that resulting from adult exposure, and this greater risk continues for at least 33 years (Ka82). As yet, however, no specific data pertaining to the effect of age at irradiation on lung cancer have been published (Ka82). Another limitation of the data for underground mine workers is the absence of women in the studied populations. The A-bomb survivor data indicate that women are about as sensitive as men to radiogenic lung cancer, even though they tend to smoke less as a group (Pr83). These data are not conclusive, however.

2.3.3 Comparison of Risk Estimates

National Academy of Sciences BEIR-3

Several estimates of the risk due to radon-222 progeny have been published since the EPA model was developed. One of particular interest was developed by the National Academy of Sciences BEIR Committee (NAS80). The BEIR-3 Committee formulated an age-dependent absolute risk model with increasing risk for older age groups. Estimates of the risk per WLM for various ages and the estimated minimum induction period for lung cancer after exposure (NAS80, pp. 325 and 327, respectively) are summarized in Table 2-2. These have been used to calculate the lifetime risk of lung cancer mortality due to lifetime exposure of persons in the general population.

Table 2-2. Age-dependent risk coefficients and minimum induction period for lung cancer due to inhaling radon-222 progeny (NAS80)

Age at diagnosis (years)	Excess lung cancers (cases per 10 ⁶ person-year WLM)	Minimum induction period (years)
0-15	0	25
16-36	0	25-15
36-50	10	10
51-64	20	10
65 or more	50	10

This was done by means of the same life table analysis that was used to calculate other EPA risk estimates (Bu81).

The zero risk shown in Table 2-2 for those under 35 years of age at diagnosis does not mean that no harm occurs; rather, it means that the risk is not expressed until the person is more than 35 years old, i.e., only after the minimum induction period. The sequence of increasing risk with age shown in this table is not unlike the increase in lung cancer with age observed in unexposed populations; therefore, the pattern of excess risk over time is similar to that found by the use of a relative risk projection model.

Atomic Energy Control Board of Canada

In their recently conducted thorough analysis of the incidence of lung cancer among uranium mine workers for the Atomic Energy Control Board (AECB) of Canada, Thomas and McNeill tested a number of risk models on all of the epidemiological studies that contained enough data to define a dose-response function (Th82). They concluded that lung cancer per WLM among males increased 2.3 percent and that a relative risk projection model was more consistent with the incidence of excess lung cancer observed in groups of underground mine workers than any of the other models they tested. This is the only analysis that treated each data set in consistent fashion and used, to the extent possible, modern epidemiological techniques such as controlling for age at exposure and duration of followup.

The estimate for lifetime exposure to Canadian males is 830 fatalities per million person WLM (Th82). For presentation in Table 2-3, this estimate has been adjusted to 600 fatalities per million person WLM (which would be the appropriate estimate for the U.S. 1970 general population) by determining the "best estimate" risk (see p. 114 in Th82). This estimate was then multiplied by the ratio of lung cancers caused by radon-222 in the U.S. 1970 general population to lung cancers in the U.S. 1970 male population as calculated in the EPA model. The 1978 reference life tables for Canadian males and U.S. males are quite similar; therefore, the simple proportional relationship of general population deaths to male deaths should give a reasonable estimate.

International Commission on Radiological Protection

The International Commission on Radiological Protection (ICRP) has made risk estimates for occupational exposure of working adults (ICRP81). The larger ICRP estimate (shown in Table 2-3) is based on an epidemiological approach; i.e., the exposure to mine workers in WLM and the risk per WLM observed in epidemiological studies of underground mine workers. The ICRP epidemiological approach assumes an average expression period of 30 years for lung cancer. Children, who have a much longer average expression period, are excluded from this estimate. The ICRP has not explicitly projected the risk to mine workers beyond the years of observation, even though most of the mine workers on whom these estimates are based are still alive and continue to die of lung cancer.

The smaller of the two ICRP estimates listed in Table 2-3 is based on their dosimetric approach. These estimates are in the lower part of the range shown for the ICRP estimate in Table 2-3. In the dosimetric approach, the ICRP assumes that the risk per rad for lung tissue is 0.12 of the risk of cancer and genetic damage after whole-body exposure (ICRP77). For exposure to radon-222 progeny, the ICRP divides this factor of 0.12 into two equal parts. A weighting factor of 0.06 is used to assess the risk from a high dose to bronchial tissue, where radiogenic lung cancer is observed in exposed underground mine workers. The other half of the lung cancer weighting factor, another 0.06 of the total body risk, is used to assess the risk to the pulmonary region, which receives a comparatively small dose from radon-222 progeny and where human lung cancer is seldom, if ever, observed.

UNSCEAR

The United Nations Scientific Committee on the Effects of Atomic Radiation (UNSCEAR) estimate shown in Table 2-3 is for a general population and assumes an expression time of 40 years (UNSCEAR77). Like the ICRP, UNSCEAR did not make use of an explicit projection of risk of fatal lung cancer over a full lifetime.

Table 2-3. Estimated risk from exposures to radon-222 progeny

Organization	Fatalities per 10 ⁶ person WLM	Exposure period	Expression period	Reference
EPA (a)	760 (460) (b)	Lifetime	Lifetime	EPA84
NAS BEIR-3 (a)	730 (440) (b)	Lifetime	Lifetime	NAS80
AECB (c)	600 (300) (b)	Lifetime	Lifetime	Th82
ICRP	150-450	Working lifetime	30 years	ICRP81
UNSCEAR	200-450	Lifetime	40 years	UNSCEAR77
NCRP (d)	130	Lifetime	Lifetime	NCRP84

- (a) The number of fatalities per million-person WLM listed for EPA and NAS BEIR-3 differs from those previously published by EPA [860 fatalities per 10⁶ PWLM and 850 fatalities per 10⁶ PWLM, respectively (EPA83a) because the increased exposure equivalent applicable to childhood has now been included. Risk estimates for various sources of radon-222 in the environment have not changed because all were calculated in a life table analysis yielding deaths per 100,000 exposed rather than deaths per 10⁶ PWLM.
- (b) The EPA and AECB estimates of risk for the general population are based on an exposure equivalent, corrected for breathing rate (and other factors). For comparison purposes, the values in parentheses express the risk in more customary form, in which a continuous exposure to 1 WL for a year corresponds to 51.6 WLM.
- (c) Adjusted for the 1970 U.S. general population; see text.
- (d) Assumes risk diminishes exponentially with a 20-year halftime.

National Council on Radiation Protection and Measurements

The National Council on Radiation Protection and Measurements (NCRP) risk estimate in Table 2-3 is based on an analysis by Harley and Pasternack (Ha82). This estimate is of particular interest because, like the EPA and AECB estimates, it is based on a life table analysis of the lifetime risk from lifetime exposure (NCRP84). This estimate uses an absolute risk projection model with a relatively low risk coefficient, 10 cases per 10^6 person WLM per year at risk, which is the smallest of those listed by the NAS BEIR-3 Committee (cf. Table 2-2). Moreover, they have assumed that the risk of lung cancer after irradiation decreases exponentially with a 20-year half-life and, therefore, exposures occurring early in life present very little risk.

The NCRP assumption of a 20-year half-life for radiation injury reduces the estimated lifetime risk by about a factor of 2.5. Without this assumption, the NCRP risk estimate would be the same as the midpoint of the UNSCEAR estimate (325 fatalities per million person WLM). The assumed decrease in risk used by NCRP is questionable. If lung cancer risk decreased over time with a 20-year half-life, the excess lung cancer observed in Japanese A-bomb survivors (following the minimum latent period) would have decreased during the period this group has been followed (1950-1982); but to the contrary, their absolute lung cancer risk has increased markedly (Ka82).

Comparison of Estimates

Good agreement exists among the EPA, NAS (BEIR-3), and the AECB estimates listed in Table 2-3. Each of these estimates is based on lifetime exposure and lifetime expression of the incurred risk. Conversely, the three lower risk estimates shown in Table 2-3 either do not explicitly include these conditions or they include other modifying factors. Nevertheless, Table 2-3 indicates a divergence, by a factor of about 6, in risk estimates for exposure to radon-222 progeny. Thus, the use of a single risk coefficient may not be appropriate, as it could give the impression that the risk is well known when obviously it is not. The EPA, BEIR-3, and AECB estimates may be slightly high because they represent relative risks based on adult males, many of whom smoked. The actual risk may be smaller for a population that includes adult females, children, and nonsmokers. The UNSCEAR and ICRP estimates are probably low because they represent absolute risk estimates that do not completely take into account the duration of the exposure and/or the duration of the risk during a lifetime. The NCRP estimate is likely to be very low, as a low risk coefficient was used in an absolute risk model, and it was assumed that the risk decreases exponentially after the exposure.

2.3.4 Selection of Risk Coefficients

To estimate the range of reasonable risks from exposure to radon-222 progeny for use in the Background Information Document for Underground Uranium Mines (EPA85), EPA averaged the estimates of BEIR-3, the EPA model, and the AECB to establish an upper bound of the range. The lower bound of the range was established by averaging the UNSCEAR and ICRP estimates. The Agency chose not to include the NCRP estimate in its determination of the lower bound because this estimate used an absolute risk projection model with a relatively low-risk coefficient. Therefore, the EPA chose relative risk coefficients of 1.2 percent per WLM and 2.8 percent per WLM (300 to 700 fatalities per million-person WLM) as reasonable estimates for the possible range of effects from inhaling radon-222 progeny for a full life time. Although these two risk estimates do not encompass the full range of uncertainty, they appeared to illustrate the breadth of much of current scientific opinion.

The lower limit of the range of relative risk coefficients, 1.2 percent per WLM, is similar to that derived by the Ad Hoc Working Group to Develop Radioepidemiological Tables, which also used 1.2 percent per WLM (NIH85). Some other estimates based only on U.S. and Czech miner data average 1 percent per WLM (Ja85) or 1.1 percent per WLM (St85).

A possible 0.5 percent per WLM lower bound of risk mentioned by the Environmental Protection Agency Radiation Advisory Committee (SAB85) appears too low. Estimates of this magnitude of risk are usually based on data from the entire cohort of U.S. white uranium miners (Th82, Wh83, Ja85, St85). The risk of exposure of 600 cumulative WLM or less, however, is usually 2.4 times or more higher than the risk for the entire cohort (Lu71, Ar79, Th82). For this reason, the 0.5 percent per WLM relative risk coefficient was not used.

The upper limit is lower than what might be justified by some current reports. Although the Swedish iron miners study (Ra84) suggested a rather high relative risk coefficient, this is a comparatively small study. In 1985, the National Institute of Occupational Safety and Health estimated the relative risk coefficient in these Swedish miners was 3.6 percent per WLM (NIOSH85). In the same year, a report on 8500 Saskatchewan uranium miners (Ho85) estimated a relative risk of 3.3 percent per WLM. In addition, a small study was made of persons exposed to different levels of radon-222 daughters and smoking in

dwellings on the Swedish island of Oeland (Ed83, 84). Data from this study could justify a relative risk coefficient of about 3.6 percent per WLM.

These three studies indicate a relative risk coefficient greater than 3 percent per WLM; therefore, the EPA is increasing the upper limit of its estimated range of relative risk coefficients. To estimate the risk due to exposure to radon-222 progeny, the EPA will use the range of relative risk coefficients of 1 to 4 percent per WLM. These risk coefficients were obtained by rounding off the coefficients listed above to the nearest whole number.

These changes are in agreement with the recommendations of the Radiation Advisory Committee of the Science Advisory Board of EPA (SAB85) which recommended that EPA use a risk coefficient range of 1 to 4 percent per WLM, as they believed that both overestimations of exposure and the effect of random error could have biased the risk coefficients downward, and a risk coefficient of 4% was recommended as an upper bound. The Committee also recommended use of single-digit risk coefficients to avoid the suggestion of a precision that does not exist. In response to these recommendations, EPA used risk coefficients of 1 to 4 percent per WLM. These risk coefficients were obtained by rounding off the coefficients discussed above. The basis for these relative risk coefficients was reviewed for this final report, but no changes were made and the risk estimates are based on 1 and 4 percent per WLM.

It may be noted here that using a 1% to 4% relative risk per WLM with the WLM Exposure Equivalent defined earlier is numerically the same as using a 0.6% to 2.4% relative risk per WLM with the conventional WLM, (see table 2-3).

2.4 Estimating the Risks

2.4.1 Exposure

The exposure to radon-222 progeny at a site of interest is based on the calculated radon-222 concentration and the calculated radon-222 progeny equilibrium fraction:

$$\begin{array}{l} \text{Radon progeny} \\ \text{concentration} \\ \text{(WL)} \end{array} = \begin{array}{l} \text{Radon} \\ \text{conc.} \\ \text{pCi/l} \end{array} \times \begin{array}{l} \text{Radon progeny} \\ \text{equil. fraction} \\ \text{(f}_{e}^{\text{eff}}\text{)} \end{array} \times \begin{array}{l} 9.84 \times 10^{-3} \\ \text{(WL per pCi/liter)} \end{array}$$

For individuals and regional populations, emission data and meteorological data are used with the AIRDOS-EPA model (Mo79) to calculate air concentrations of radon-222; for national populations, emission data and meteorological data are used with the NOAA Trajectory Dispersion Model (NRC79).

Calculations of radon-222 progeny equilibrium fractions are based on distance from a source and the time required to reach the exposure site. By using the ingrowth model of Evans (Ev69) and the potential alpha energy data of UNSCEAR (UNSCEAR77), the outdoor equilibrium fraction can be calculated by the expression:

$$f_e^{\text{out}} = 1.0 - 0.0479e^{-t/4.39} - 2.1963e^{-t/38.6} + 1.2442e^{-t/28.4}$$

where t is the travel time in minutes (distance/transport velocity).

The indoor equilibrium fraction presumes that those decay products associated with the radon-222 release also enter the building and that a ventilation rate of 1 h^{-1} (one air change per hour) in combination with indoor removal processes (e.g., deposition onto room surfaces) produces an indoor equilibrium fraction of 0.35 when there are no decay products in the ventilation air and 0.70 when the decay products are in equilibrium with the radon-222 in the ventilation air (EPA83b). A simple linear interpolation is used to obtain the indoor equilibrium fraction:

$$f_e^{\text{in}} = 0.35 (1 + f_e^{\text{out}}).$$

If one further assumes that a person spends 75 percent of his or her time indoors and the remaining 25 percent outdoors at the same location, the effective equilibrium fraction is given by:

$$f_e^{\text{eff}} = 0.75 f_e^{\text{in}} + 0.25 f_e^{\text{out}} = 0.2625 + 0.5125 f_e^{\text{out}}$$

An example of the case for a 3.5 m/s windspeed and various distances from the source is given in Table 2-4. Removal processes outdoors were assumed to limit the equilibrium fraction to 0.85, which corresponds to an indoor equilibrium fraction of 0.65 and an effective fraction of 0.70. Table 2-4 shows that this limit is reached at a distance of 19,550 meters.

2.4.2 Risk Estimation

After the exposure equivalent has been calculated, the risk can be estimated for an individual or a population.

Individual

Individual risks are calculated by using the life table methodology described by Bunker et al. (Bu81). Relative risk

Table 2-4. Radon-222 decay product equilibrium fraction at selected distances from the center of a 80 ha. tailings impoundment^(a)

Distance (m)	f_e out	f_e in	f_e eff
0	0.008 ^(b)	0.353	0.267
100	0.009	0.353	0.267
150	0.013	0.355	0.269
200	0.020	0.357	0.273
250	0.026	0.359	0.276
300	0.031	0.361	0.278
400	0.041	0.364	0.284
500	0.051	0.368	0.289
600	0.060	0.371	0.293
800	0.078	0.377	0.302
1,000	0.094	0.383	0.311
1,500	0.133	0.397	0.331
2,000	0.168	0.409	0.349
2,500	0.201	0.421	0.366
3,000	0.234	0.432	0.382
4,000	0.295	0.453	0.414
5,000	0.353	0.473	0.443
6,000	0.407	0.493	0.471
8,000	0.507	0.527	0.522
10,000	0.593	0.558	0.566
15,000	0.755	0.614	0.650
19,550	0.850	0.648	0.698

(a) Calculations (tabulated to 3 decimal places to facilitate comparisons) presume: a 3.5 m/s windspeed for the outdoor equilibrium fraction; an indoor equilibrium fraction of 0.35 for no radon-222 decay products in the ventilation air and 0.70 for ventilation air with 100 percent equilibrium between radon-222 and its decay products; and an effective equilibrium fraction based on 75 percent of time indoors and 25 percent of time outdoors.

projections for lifetime exposure based on coefficients of 1.0 percent and 4.0 percent per WLM for the radiation-induced increase in lung cancer yield rounded-off estimates of 380 deaths/10⁶ person WLM and 1520 deaths/10⁶ person WLM, respectively when using updated age specific mortality and the 1980 life table data. These risk projections compare to the estimate of 250 and 1000 deaths/10⁶ person WLM used in the Draft Background Information Document which were based on the 1970 life tables. The updated estimates used in this final document are based on the same risk coefficients but yield higher death rates since there are more people in each age category and there is a higher total incidence of lung cancer.

These risk coefficients can be used in the CAIRD Code (Co78) to calculate the risk from any exposure to radon-222 progeny across any time period. Usually, the lifetime risk from lifetime exposure at a constant level is calculated. The age-specific differences in exposure equivalent listed in Table 2-1 are included in calculations of the lifetime risk.

One of the characteristics of the life table based calculations is that the same risk coefficients will yield different estimates of life time risk when different life tables are used. This is particularly true of relative risk projections when both the life table and the age-specific mortality data in the calculation may be changed. Prior ORP relative risk estimates were based on the 1970 life table (NCHS75) and the 1970 mortality data (NCHS73). For this document the basis for calculation has been changed to the recently available 1980 life table (NCHS85) and 1980 mortality data (NCHS83).

Although this change provides risk estimates more appropriate for the 1980s, the increase in the life span reflected in the life table and, more significantly, the increase in lung cancer mortality (Figures 2-2 and 2-3) have caused an appreciable upward change in the risk estimate. Lifetime risk estimates made using the relative risk projection with 1980 vital statistics are about 50% greater than those made earlier using the 1970 vital statistics. Thus, the updated estimates used in this final document are based on the same risk coefficients (1% and 4% increase per WLM), but yield higher numerical risks since there are more people in each age category and there is a higher rate of lung cancer mortality for each age.

Results of representative calculations of lifetime risk using 1980 data are given in Table 2-5.

Table 2-5. Lifetime risk for lifetime exposure to a given level of radon-222 progeny (1980 Life Table, 1980 Mortality Data)

Lifetime risk of lung cancer		
Radon-222 progeny concentration (WL)	4 percent increase per WLM	1 percent increase per WLM
0.0001	3.5×10^{-4}	8.8×10^{-5}
0.001	3.5×10^{-3}	8.8×10^{-4}
0.01	3.4×10^{-2}	8.8×10^{-3}
0.1	2.8×10^{-1}	8.3×10^{-2}
0.2	4.5×10^{-1}	1.6×10^{-1}

The lifetime risk estimates shown in Table 2-5 are for lifetime exposure at a constant level of radon-222 progeny. These risk estimates were used with WL exposures that were calculated by using radon-222 concentrations and an f_{eff} determined as shown in Table 2-4 to estimate the risks of fatal lung cancer due to maximum exposure of individuals living nearest the tailings impoundments (Table 6-1).

Lifetime risk factors for selected concentrations of radon-222 in air with relative risk coefficients of 1 percent and 4 percent per WLM are shown in Table 2-6 in a manner similar to Table 2-5.

Table 2-6. Lifetime risk for lifetime exposure to a given level of radon-222 in air

<u>Lifetime risk of lung cancer</u>			
Radon-222 concentrations (pCi/l)		4 percent increase per WLM	1 percent increase per WLM
	(WL) (a)		
10	6.9×10^{-2}	2.1×10^{-1}	5.9×10^{-2}
3	2.1×10^{-2}	7.1×10^{-2}	1.8×10^{-2}
1	6.9×10^{-3}	2.4×10^{-2}	6.1×10^{-3}
0.3	2.1×10^{-3}	7.4×10^{-3}	1.8×10^{-3}
0.1	6.9×10^{-4}	2.4×10^{-3}	6.1×10^{-4}

(a) At equilibrium fraction of 0.7.

Regional

Collective (population) risks for the region are calculated from the annual collective exposure (person WLM) for the population in the assessment area by a computerized methodology known as AIRDOS-EPA (Mo79). An effective equilibrium fraction of 0.7 is presumed because little collective exposure takes place near the source.

Formally, the annual collective exposure, S_E , can be defined as:

$$S_E = \int_0^{\infty} E n(E) dE$$

where S_E is the collective exposure (person WLM), E is the exposure level (WLM), and $n(E)$ is the population density at exposure level E (person/ WLM).

Practically, however, the collective exposure is calculated by dividing the assessment area into cells and then calculating the population, N_i (persons), and the annual exposure, E_i (WLM), for each one. The collective exposure is then calculated by the following expression:

$$S_E = \sum_i E_i N_i$$

where the summation is carried out over all the cells. Customarily, the regional population exposure is limited to persons within 80 km of the source.

The same risk factors used for the individual risk calculations (4 percent increase per WLM or 1 percent increase per WLM) are also used to calculate the population risk.

National

Radon-222 released from a source can be transported beyond the 80-km regional cutoff. A trajectory dispersion model developed by NOAA (NRC79) has been used to estimate the national impact of radon-222 releases from a source. This model calculates the average radon-222 exposure to the U.S. population from unit releases at four typical uranium mining and milling sites. The model yields radon-222 concentrations (in picocuries per liter) in air, which are then converted to decay product exposures by assuming an effective equilibrium fraction of 0.7. National annual collective exposures (person-WLM) are calculated for distances beyond the 80-km regional limit. The exposures and risks are calculated for a total population of 200 million persons.

REFERENCES

- Ar79 Archer V. E., Radford E. P., and Axelson O., "Factors in Exposure-Response Relationships of Radon Daughter Injury", in: Conference/Workshop on Lung Cancer Epidemiology and Industrial Applications of Sputum Cytology, Colorado School of Mines, Golden, Colorado, pp. 324-367, 1979.
- Bu81 Bunger B., Cook J. R., and Barrick M. K., "Life Table Methodology for Evaluating Radiation Risk: An Application Based on Occupational Exposure", Health Physics 40, 439-455, 1981.
- Ch84 Chameaud J., Masse R., and Lafuma J., "Influence of Radon Daughter Exposure at Low Doses on Occurrence of Lung Cancer in Rats", Radiat. Prot. Dos. 7, 385-388, 1984.
- Ch85 Chameaud J., Masse R., Morin M., and Lafuma J., "Lung Cancer Induction by Radon Daughters in Rats", in: Occupational Radiation Safety in Mining, Vol. 1, H. Stocker, editor, Canadian Nuclear Assoc., Toronto, Canada, pp. 350-353, 1985.
- Co78 Cook J. R., Bunger B. M., and Barrick M. K., "A Computer Code for Cohort Analysis of Increased Risk of Death (CAIRD)", Technical Report 520/4-78-12, Office of Radiation Programs, USEPA, Washington, D.C., 1978.
- Ed83 Edling C., Kling H., and Axelson O., "Radon in Homes - A Possible Cause of Lung Cancer", in: Lung Cancer and Radon Daughter Exposure in Mines and Dwellings. Linkoping University Medical Dissertations No. 157, by Christer Edling, Department of Occupational Medicine, Linkoping University, Linkoping, Sweden, pp. 123-149, 1983.
- Ed84 Edling C., Wingren G., and Axelson O., "Radon Daughter Exposure in Dwellings and Lung Cancer", in: Indoor Air, Volume 2: Radon, Passive Smoking, Particulates and Housing Epidemiology, B. Berglund, T. Lindvall and J. Sundell, editors, Swedish Council for Building Research, Stockholm, Sweden, pp. 29-34, 1984.

- E179 Ellett W. H. and Nelson N. S., "Environmental Hazards From Radon Daughter Radiation", in: Conference/ Workshop on Lung Cancer Epidemiology and Industrial Applications of Sputum Cytology, Colorado School of Mines Press, Golden, Colorado, pp. 114-148, 1979.
- E185 Ellett W. H. and Nelson N. S., "Epidemiology and Risk Assessment: Tests of Models for Lung Cancer Induction, in: Indoor Air and Human Health", R. B. Gammage and S. V. Kaye, editors, Lewis Publishers, Inc., Chelsea, Michigan, pp. 79-107, 1985.
- EPA79 Environmental Protection Agency, "Indoor Radiation Exposure Due to Radium-226 in Florida Phosphate Lands", EPA 520-4-78-013, Office of Radiation Programs, USEPA, Washington, D. C., revised printing, July 1979.
- EPA82 Environmental Protection Agency, "Final Environmental Impact Statement for Remedial Action Standards for Inactive Uranium Processing Sites (40 CFR 192), Volume I", EPA 520/4-82-013-1, Office of Radiation Programs, USEPA, Washington, D.C., 1982.
- EPA83a Environmental Protection Agency, "Final Environmental Impact Statement for Standards for the Control of Byproduct Materials from Uranium Ore Processing (40 CFR 192), Volume I", EPA 520/1- 83-008-1, Office of Radiation Programs, USEPA, Washington, D.C., 1983.
- EPA83b Environmental Protection Agency, "Final Environmental Impact Statement for Standards for the Control of Byproduct Materials From Uranium Ore Processing (40 CFR 192), Volume II", p. A.2-33, EPA 520/1-83-008-2, Office of Radiation Programs, USEPA, Washington, D.C., 1983.
- EPA84 Environmental Protection Agency, "Radionuclides Background Information Document for Final Rules, Volume I", EPA 520/1-84- 022-1, Office of Radiation Programs, USEPA, Washington, D.C. 1984.
- EPA85 Environmental Protection Agency, "Background Information Document--Standard for Radon-222 Emissions from Underground Uranium Mines", EPA 502/1-85-010, Office of Radiation Programs, USEPA, Washington, D.C. 1985.
- Ev69 Evans R., "Engineers Guide to the Elementary Behavior of Radon Daughters", Health Physics, 17, 229-252, 1969.

- FRC67 Federal Radiation Council, "Radiation Guidance for Federal Agencies, Memorandum for the President", July 21, 1967, 32 FR 11183, 84, August 1, 1967.
- Ha82 Harley N. H. and Pasternack B. S., "Environmental Radon Daughter Alpha Dose Factors in a Five-Lobed Human Lung", Health Physics, 42, 789-799, 1982.
- Ho77 Hofmann W. and Steinhausler F., "Dose Calculations for Infants and Youths Due to the Inhalation of Radon and Its Decay Products in the Normal Environment", in: Proceedings of the 4th International Congress of the International Radiation Protection Association, Paris, 2, 497-500, 1977.
- Ho82 Hofmann, W. "Cellular Lung Dosimetry for Inhaled Radon Decay Products as a Base for Radiation-Induced Lung Cancer Risk Assessment", Radiat. Environ. Biophys., 20:95-112 (1982).
- Ho85 Howe G. R., "Presentation at the Society for Epidemiological Research", 19th Annual Meeting, Chapel Hill, North Carolina, June 18-21, 1985.
- ICRP75 International Commission on Radiological Protection, "Report of the Task Group on Reference Man", ICRP Publ. 23, Pergamon Press, New York, 1975.
- ICRP77 International Commission on Radiological Protection, "Recommendations of the International Commission on Radiological Protection", ICRP Publ. 26, Ann. ICRP, 1 (1), Pergamon Press, 1977.
- ICRP79 International Commission on Radiological Protection, "Limits for Intakes of Radionuclides by Workers", ICRP Publication 30, Part 1, Ann. ICRP, 2 (3/4), Pergamon Press, New York, 1979.
- ICRP81 International Commission on Radiological Protection, "Limits for Inhalation of Radon Daughters by Workers", ICRP Publication 32, Ann. ICRP, 6, Pergamon Press, 1981.
- Ja80 Jacobi W. and Eisfeld K., "Dose to Tissue and Effective Dose Equivalent by Inhalation of Radon-222 and Radon-220 and Their Short-Lived Daughters", GFS Report S-626, Gesellschaft für Strahlen und Umweltforschung mbH, Munich, 1980.

- Ja81 James A. C., Jacobi W. and Steinhausler F., "Respiratory Tract Dosimetry of Radon and Thoron Daughters: The State-of-the-Art and Implications for Epidemiology and Radiology", in: Proceedings of the International Conference on Hazards in Mining: Control, Measurement, and Medical Aspects, October 4-9, 1981, Golden, Colorado, editor Manual Gomez, Society of Mining Engineers, New York, pp. 42-54, 1981.
- Ja85 Jacobi W., Paretzke H. G. and Schindel F., "Lung Cancer Risk Assessment of Radon-Exposed Miners on the Basis of a Proportional Hazard Model", in: Occupational Radiation Safety in Mining, Volume 1, H. Stocker, editor, Canadian Nuclear Association, Toronto, Ontario, Canada, pp. 17-24, 1985.
- Ka82 Kato H. and Schull W. J., "Studies of the Mortality of A-bomb Survivors, 7. Mortality, 1950-1978: Part I", Cancer Mortality, Rad. Research, 90, 395-432, 1982. (Also published by the Radiation Effect Research Foundation as: RERF TR 12-80, Life Span Study Report 9. Part 1.)
- Lu71 Lundin F. E. Jr., Wagoner J. K. and Archer V. E., "Radon Daughter Exposure and Respiratory Cancer, Quantitative and Temporal Aspects", Joint Monograph No. 1, U.S. Public Health Service, U.S. Department of Health, Education and Welfare, Washington, D.C., 1971.
- Mc78 McDowell E. M., McLaughlin J. S., Merenyi D. K., Kieffer R. F., Harris C. C., and Trump B. F., "The Respiratory Epithelium V. Histogenesis of Lung Carcinomas in Humans", J. Natl. Cancer Inst., 61, 587-606, 1978.
- Mc83 McDowell E. M. and Trump B. F., "Histogenesis of Preneoplastic and Neoplastic Lesions in Tracheobronchial Epithelium", Surv. Synth. Path. Res., 2, 235-279, 1983.
- Mo76 Moeller D. W. and Underhill D. W., "Final Report on Study of the Effects of Building Materials on Population Dose Equivalent", School of Public Health, Harvard University, Boston, Massachusetts, December 1976.

- Mo79 Moore R. E., Baes C. F. III, McDowell-Boyer L. M., Watson A. P., Hoffman F. O., Pleasant J. C., and Miller C. W., "AIRDOS-EPA: A Computerized Methodology for Estimating Environmental Concentrations and Doses to Man from Airborne Releases of Radionuclides", ORNL-5532, Oak Ridge National Laboratory, Oak Ridge, Tennessee, 1979.
- Mu83 Muller J., Wheeler W. C., Gentleman J. F., Suranyi G., and Kusiak R. A., "Study of Mortality of Ontario Miners, 1955-1977, Part I", Ontario Ministry of Labor, Ontario, Canada, May 1983.
- NAS72 National Academy of Sciences - National Research Council, "The Effects of Populations of Exposures to Low Levels of Ionizing Radiation", Report of the Committee on the Biological Effects of Ionizing Radiations (BEIR Report), NAS, Washington, D.C., 1972.
- NAS80 National Academy of Sciences - National Research Council, "The Effects of Populations of Exposures to Low Levels of Ionizing Radiation: 1980", Committee on the Biological Effects of Ionizing Radiation (BEIR-3 Report), NAS, Washington, D.C., 1980.
- NASA73 National Aeronautics and Space Administration, "Bioastronautics Data Book", NASA SP-3006, 2nd Edition, J. R. Parker and V. R. West - editors, NASA, Washington, D.C., 1973.
- NCHS73 National Center for Health Statistics, "Public Use Tape, Vital Statistics - Mortality, Cause of Death Summary - 1970", PB80-133333, NTIS, Washington, D.C., 1973.
- NCHS75 National Center for Health Statistics, "U.S. Decennial Life Tables for 1969-1971, Volume 1, No. 1", DHEW Publication No. (HRA) 75-1150. U.S. Department of Health, Education and Welfare, USPHS, NCHS, Rockville, Maryland, 1985.
- NCHS83 National Center for Health Statistics, "Public Use Tape, Vital Statistics - Mortality, Cause of Death Summary - 1980", PB83-261578, NTIS, Washington, D.C., 1983.

- NCHS85 National Center for Health Statistics, "U.S. Decennial Life Tables for 1979-1981, Volume 1, No. 1, United States Life Tables", PHS Publication No. 85-1150-1, Department of Health and Human Services, USPHS, NCHS, Hyattsville, Maryland, 1985.
- NCRP84 National Council on Radiation Protection and Measurements, "Evaluation of Occupational and Environmental Exposures to Radon and Recommendations", NCRP Report No. 78, NCRPM, Washington, D.C., 1984.
- NIH85 National Institutes of Health, "Report of the National Institutes of Health Ad Hoc Working Group to Develop Radioepidemiological Tables", NIH Publication No. 85-2748, U.S. Department of Health and Human Services, NIH, Bethesda, Maryland, 1985.
- NIOSH85 National Institute for Occupational Safety and Health, "Evaluation of Epidemiologic Studies Examining the Lung Cancer Mortality of Underground Miners", National Institute for Occupational Safety and Health, CDC, Cincinnati, Ohio, May 9, 1985.
- NRC79 Nuclear Regulatory Commission, Draft Generic Environmental Impact Statement on Uranium Milling, Volume II, NUREG-0511, USNRC, Washington, D.C., 1979.
- Oa72 Oakley D. T., "Natural Radiation Exposure in the United States", ORP/SID 72-1, USEPA, Washington, D.C., 1972.
- Po78 Porstendorfer J., Wicke A., and Schraub A., "The Influence of Exhalation, Ventilation, and Deposition Processes Upon the Concentration of Radon, Thoron and Their Decay Products in Room Air", Health Physics, 34, 465-473, 1978.
- Pr83 Prentice R. L., Yoshimoto Y., and Mason M. W., "Relationship of Cigarette Smoking and Radiation Exposure to Cancer Mortality in Hiroshima and Nagasaki", J. Nat. Cancer Inst., 70, 611-622, 1983.
- Ra84 Radford E. P., and Renard K. G. St. Cl., "Lung Cancer in Swedish Iron Miners Exposed to Low Doses of Radon Daughters", N. Engl. J. Med., 310, 1485-1494, 1984.
- Ra85 Radford, E.P. "Radon Daughters and Lung Cancer". N. Engl. J. Med., 313:1610-1611 (1985).

- SAB85 Science Advisory Board, "Letter from the Radiation Advisory Committee of the Science Advisory Board of EPA to Lee M. Thomas, Administrator of EPA, dated November 5, 1985", on the subject of EPA radon risk estimates.
- Sp56 Spector W. S., editor, "Handbook of Biological Data, Table 314, Energy Cost, Work: Man", W. B. Sanders Co., Philadelphia, 1956.
- St85 Steinhausler F., and Hofmann W., "Inherent Dosimetric and Epidemiological Uncertainties Associated with Lung Cancer Risk Assessment in Mining Populations", in: Occupational Radiation Safety in Mining, Volume 1, H. Stocker, editor, Canadian Nuclear Association, Toronto, Ontario, Canada, pp. 327-334, 1985.
- Th82 Thomas D. C., and McNeill K. G., "Risk Estimates for the Health Effects of Alpha Radiation", Report INFO-0081, Atomic Energy Control Board, Ottawa, Canada, 1982.
- UNSCEAR77 United Nations Scientific Committee on the Effects of Atomic Radiation, "Sources and Effects of Ionizing Radiation", Report to the General Assembly, with Annexes, UN publication E. 77 IX.1., United Nations, New York, 1977.
- Wh83 Whitemore A. S. and McMillar A., "Lung Cancer Mortality Among U.S. Uranium Miners: A Reappraisal", Technical Report No. 68, Department of Statistics, Stanford University, California, 1983.

Chapter 3: RADON-222 SOURCES, ENVIRONMENTAL TRANSPORT, AND RISK ESTIMATES

3.1 Introduction

This chapter presents the physical and chemical properties of radon-222, where and how it is emitted from the uranium milling process, and how it is transported through the environment. Also presented are the methods used to model the dispersion of the radon-222 and a description of how the health risks associated with these emissions are estimated.

3.2 Origin and Properties of Radon-222

Uranium ore contains both uranium and its decay products, including significant concentrations of radium-226. Radon-222 is a naturally occurring radioactive gaseous element that is formed by the radioactive decay of radium-226. Radium-226 is a long-lived (1620-year half-life) decay product of the uranium-238 series. In nature, uranium is about 99.3 percent uranium-238; thus, it is the decay products of uranium-238 (shown in Figure 3-1) that govern the radioactive content of the ore (NRC81). Other isotopes of radon (radon-219 and radon-220) occur from the decay of uranium-235 and thorium-232, but these isotopes have short half-lives of 3.96 and 55.6 seconds, respectively, and have little environmental impact due to the short half-lives of the decay products. Important properties of radon-222 are presented in Table 3-1 for information purposes only.

Mined uranium ore is milled to extract the uranium-238. Milling removes about 90 percent of the uranium-238 from the ore. The remaining uranium-238 and essentially all other radioactive elements (including thorium-230) present in the ore are left behind and disposed of with the mill waste (tailings). These tailings will remain radioactive for hundreds of thousands of years.

Radon-222 is the only member of the decay chain that is a gas. It is a noble gas and therefore does not usually combine with other elements to form nongaseous compounds. As a gas, radon-222 is released to the atmosphere if it escapes (emanates from) the mineral matrix that contains its parent, radium-226. The subsequent radioactive decay of radon-222 produces a series of solid radioactive products called "radon progeny." If radon-222 is airborne at the time of its decay, these radon progeny become attached to dust particles in the air and can be inhaled and deposited in the lungs (NRC81).

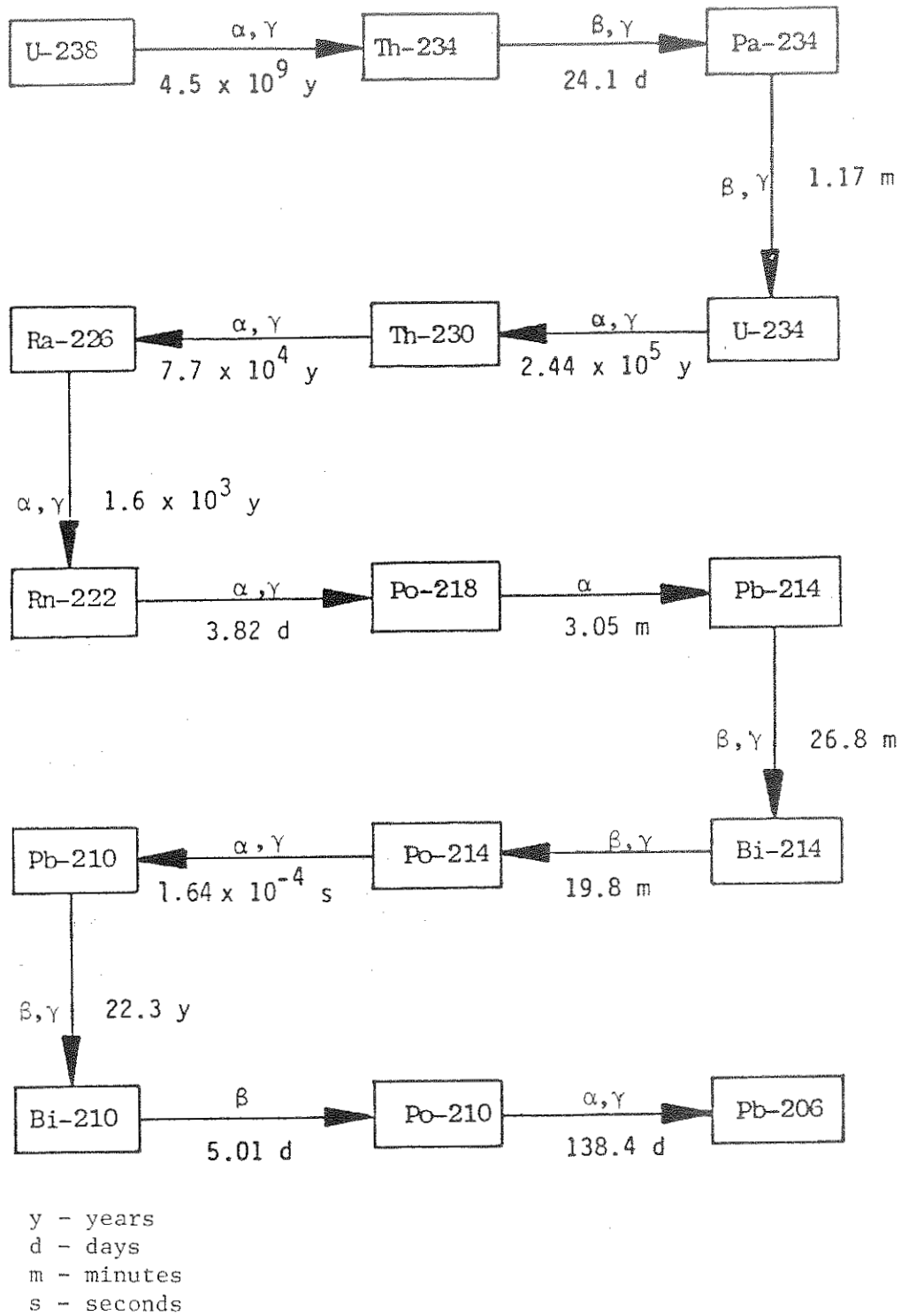

Figure 3-1. Uranium-238 decay chain and half-lives of principal radionuclides.

Table 3-1. Properties of radon-222^(a)

Property	Value
Atomic number	86
Atomic weight	222
Boiling point	-62°C
Melting point	-71°C
Density	9.73 grams/liter
Solubility in water	51 cm ³ in 100 grams at 0°C 8.5 cm ³ in 100 grams at 60°C
Half-life	3.824 days
Decay modes and energy	
α	5.4897 MeV
γ	0.512 MeV

(a) Source: Chemical Engineer's Handbook, Perry, J. H. (editor), McGraw-Hill Book Co., New York, New York, 1983, and Chart of the Nuclides, Knolls Atomic Power Laboratory, Operated by General Electric Co. for U.S. Dept. of Energy, 12th Edition, April 1977.

Radon-222 that enters the atmosphere can be transported over great distances. At distances beyond about a mile, however, the contribution of radon-222 concentrations from the mills and tailings piles is indistinguishable from natural background (NRC81). Some uranium-238, 1-2 ppm, is present in most soils; therefore, radon-222 is emitted constantly from the Earth's surface (NRC81). It is estimated that 120 million Ci/y of radon-222 is emitted from undisturbed soil and an additional 3 million Ci/y is emitted from tilled soil (NRC81). In comparison, uranium tailings disposal at licensed mills currently contributes about 140,000 Ci/y (PEI85).

3.3 Sources of Radon-222 Emissions in the Milling Process

Uranium ore is processed in mills to recover and concentrate uranium to an intermediate, semirefined product often called "yellowcake." This yellowcake is sent to separate refining facilities that produce uranium metal, UO_2 , or UF_6 . Conventional uranium milling involves a series of unit operations, including ore handling and preparation, extraction, concentration and precipitation, product preparation, and tailings disposal.

Ore stockpiles, crushing and grinding operations, the extraction circuit, and tailings piles are sources of radon-222 at operational uranium mills, as illustrated in Figure 3-2. Other sources, such as contaminated former ore storage areas, also release radon-222. These sources, however, are comparatively small in comparison with tailings and of such uncertainty in size, source strength, and frequency of occurrence that they are omitted from the present analyses.

Radon-222 releases can be characterized as total-release events or continual, diffusion-limited releases. Thick or deep sources, such as ore storage piles and mill tailings impoundments, that remain undisturbed for extended periods of time release radon-222 by diffusive and advective mechanisms. Accordingly, the radon-222 emission is often characterized by a mathematical diffusion expression of the radon-222 flux. Conversely, sources that rapidly release radon-222 during a mechanical disturbance, such as the crushing and grinding operation, are best characterized by a radon-222 release per unit mass; e.g., picocuries of radon-222 per picocuries radium-226 present. This release can then be expressed in terms of the amount of U_3O_8 produced by the mill.

The domestic uranium ores currently mined contain an average of about 0.1 percent uranium. When uranium ore lies underground, only a very small fraction (if any) of the radon-222 it produces

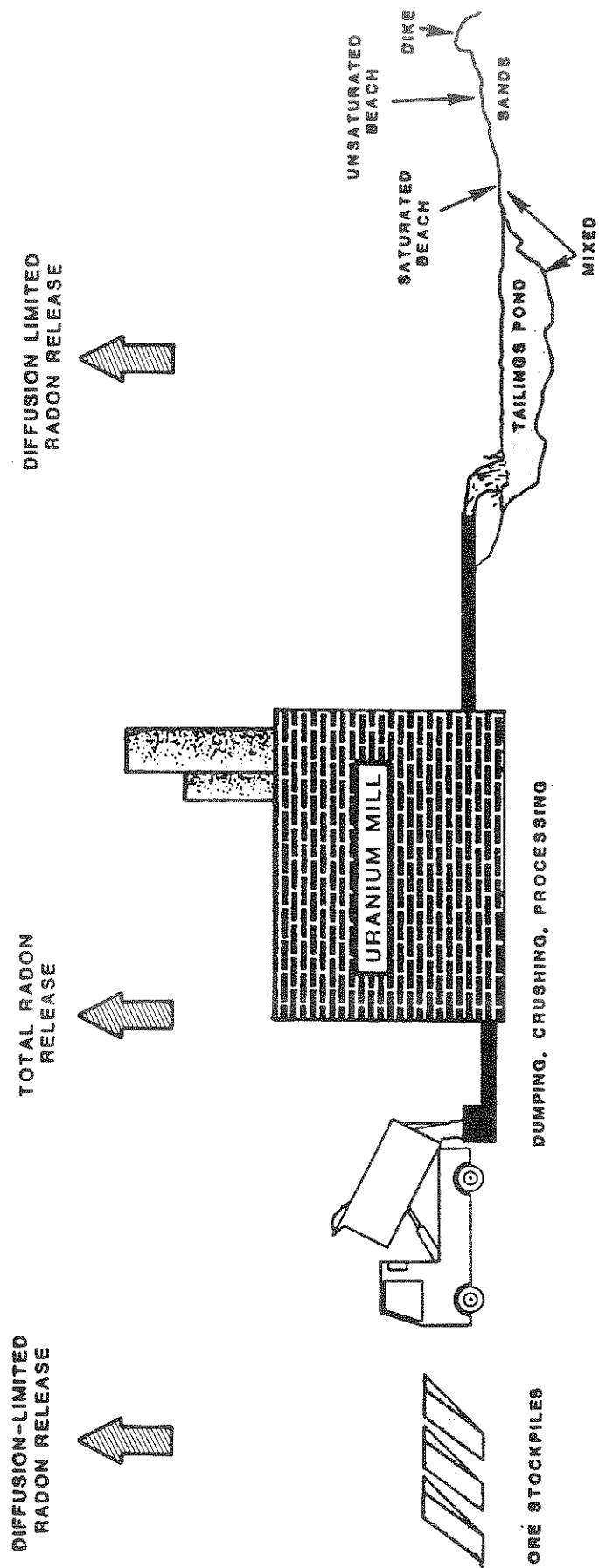

Figure 3-2. Schematic illustration of the radon sources at a uranium mill (PEI85).

escapes to the atmosphere. Radon-222 has a half-life of only 3.8 days; therefore, most of the radon-222 that is generated more than a few meters below the surface decays into nongaseous radionuclides before it can migrate through the soil pore space (the air space between soil particles) and escape into the atmosphere. When uranium ore is mined and milled, however, the handling and grinding operations liberate radon-222 contained in the pores in the ore. Milling of the ore to sand-sized particles also allows a greater portion of the radon-222 that forms in the tailings to be released into the atmosphere by diffusive and advective mechanisms. Both the increased surface area of the particles and increased porosity resulting from the milling process cause an increase in the portion of radon-222 that escapes to the atmosphere.

Ore Handling and Preparation

Ore handling and preparation include ore blending, storage, crushing, fine ore storage, and grinding. Ore blending ensures that the mill feed is of uniform grade, which is necessary to achieve maximum efficiency in the mill circuit. Blending may be performed at either the mine or the mill. Ore is stored in stockpiles on ore pads at the mill site. The stockpiles provide sufficient feed for a continuous supply to the mill. Ore received from the mine often has a high moisture content; however, the dry climate typical of the major uranium districts causes rapid drying. For this reason, some ore storage piles are sprayed with water to maintain their moisture content and to reduce dusting.

Storage pads typically cover several acres and provide enough ore storage to feed the mill for one or two months of operation. Ore usually is not kept on the storage pad when the mills are on standby status. Similarly, when operations are reduced because of a depressed economy, as they currently are, a lesser quantity of ore is stockpiled at the mill site than would be if the mill were operating at full capacity. The ore residence time in storage piles varied from 4 to 180 days, with a mean and standard deviation of 87 ± 72 days, at seven mills surveyed in Wyoming (Th82).

The number of piles can be estimated by the product of the mill feed rate (weight/day) and the stockpile residence time (days) divided by the mass of a pile. The piles vary in shape among different mills, but they are frequently conical, oblong, or wedge-shaped. A maximum height of 10 m (30 ft) and 45-degree sloping sides are common. The volume and surface area of a typical pile have been estimated to be 8000 m³ and 2500 m², respectively (Th82). Emissions of radon-222 from stockpiles are

considered to emanate from an infinitely deep or thick source from all surfaces, even though some parts may be shallow or thin. The resulting high radon-222 emission estimate for some of the pile areas is justified by the variable sizes, shapes, and other characteristics of ore stockpiles.

Stockpiles initially emit no radon-222 because all of the emanated radon-222 stored in the pores of the ore was released as the ore was mined and transported to the stockpiles. As new radon-222 emanates into the pore space of the ore, the interstitial radon-222 levels and the escaping radon-222 flux increase. After several weeks, a nearly constant radon-222 flux (emission rate) is attained.

Crushing is the first stage of size reduction and involves the use of impact and/or gyratory crushers. Crushing typically reduces mine run ore to between minus 3/4 inch and minus 1-1/2 inch size (Me71). Fine ores (undersized material) bypass the crushing circuit and are conveyed directly to fine-ore storage bins. Air exhaust hoods with dust collectors are located on crushers and screens and at transfer points to minimize particulate emissions, and air is exhausted to the atmosphere via vents. The dust collectors do not capture radon-222 emanating from the ore during these processes, and it is vented to the atmosphere. Crushing plant capacities range from 70 to 320 tons per hour (NRC80).

Crushed and undersized ore is stored in cylindrical fine-ore bins about 7 to 10 m (25 to 35 feet) in diameter. These bins provide a fine-ore storage capacity up to double the rated daily milling capacity (NRC80). Radon-222 that emanates from the fine ore in storage is vented to the atmosphere.

Belt-type feeders convey the ore from the crushing circuit and fine-ore bins to the grinding circuit, where rod and ball mills or semiautogenous mills are used to reduce the ore size further. Occasionally, the ore is roasted before it is sent to the grinding circuit to reduce moisture before grinding, to increase the solubility of other valuable constituents (e.g., vanadium), or to improve the physical characteristics of the ore. The ores are ground dry and then slurried with water or wet-ground to yield a pulp density of 50 to 65 percent solids (NRC80). Classifiers, thickeners, cyclones, or screens are used to size the ore, and coarser particles are returned for further grinding. One mill uses an alkaline leaching process, which requires the ore be ground much finer (200-mesh) than for acid leaching (28-mesh).

Wet, semiautogenous grinding is being used increasingly in place of dry crushing or ball and rod mill grinding operations, which may be run wet or dry. The semiautogenous grinder performs the ore sizing function of these operations and reduces or eliminates dry ore handling.

The total release of radon-222 from the dumping, crushing, and extraction processes occurs mostly during the process of transferring and dumping the ore into the mill feed area. The ore is typically reduced to sizes of less than 40 cm, which is the relaxation diameter for radon-222 diffusion from ore pieces with diffusion coefficients of 10^{-3} cm²/s; therefore, radon-222 escapes readily from the pores of the ore when it is handled and results in the total release of accumulated radon-222. During the remainder of the short milling process, little additional radon-222 escapes from the ore for release. Hard-rock uranium ores are an exception, in that they have very low diffusion coefficients for radon-222 (10^{-4} to 10^{-5} cm²/s). The 4 to 14cm particles of these ores can significantly reduce radon-222 releases; hence, the sharp one-time release is less and is delayed until the ore is ground to smaller particle sizes during milling.

Extraction

Hydrometallurgical leaching techniques are used to recover uranium from the ground ore slurry. Little radon-222 is released from the extraction process because the radon-222 contained in the ore is released during initial ore handling and size reduction steps and the relatively short milling time (less than 24 hours) does not permit significant formation of new radon-222. The extraction process uses sulfuric acid or an alkaline carbonate solution for lixivation. Acid leaching is preferred for ores with low lime content (12 percent or less) (NRC80) and is the predominant leach process in the United States. A flow diagram of the acid leach/solvent extraction process is shown in Figure 3-3.

The leaching circuit consists of a series of mechanically agitated tanks having a total ore residence time of approximately 7 hours. The pH in the tanks is maintained between 0.5 and 2.0 by adding sulfuric acid. The free acid concentration is from 1 to 90 grams of acid per liter during the contact period (NRC80). Acid leaching is carried out at atmospheric pressure and slightly above room temperature.

After leaching, the pregnant leach solution is separated from the tailing solids in a countercurrent decantation (CCD) circuit. The sands and slimes are pumped to a tailings pond for disposal.

Alkaline leaching, which is best suited to ores with high lime content, may be used in combination with ion exchange or caustic precipitation to concentrate and purify uranium. A flow diagram of the alkaline leach/caustic precipitation process is shown in Figure 3-4.

The ore slurry is leached in a two-stage system (pressure leaching followed by atmospheric leaching). The leach solution contains sodium carbonate (40 to 50 grams per liter) and sodium bicarbonate (10 to 20 grams per liter). Circular tanks are used and air is added to oxidize the uranium to the hexavalent state. Residence time varies from 21 to 33 hours. The pregnant leach solution is separated from the tailings in a series of CCD filtrations.

Concentration and Precipitation

Three techniques are used to concentrate uranium from the pregnant leach solution: ion exchange, solvent extraction, and the Eluex process, which is a combination of ion exchange and solvent extraction. Uranium that has been concentrated by one of these methods is precipitated from the solution by the addition of gaseous ammonia (NH_3), sodium hydroxide (NaOH), hydrogen peroxide (H_2O_2), or magnesia (MgO) in several stages under controlled pH. Most mills use gaseous ammonia. The precipitated uranium is dewatered in thickeners and then filtered and washed in drum, plate, or frame filters. At this point, the resulting filter cake still contains considerable moisture.

Product Preparation

The uranium filter cake (yellowcake) is dried in a continuous steam-heated dryer or in a multiple-hearth dryer. The dried yellowcake is crushed and screened to the required size and packaged in 55-gallon drums for shipment. Some radon-222 emanates from this operation and is vented to the atmosphere.

Tailings Disposal

With the exception of the uranium extracted during milling, the dry weight of the tailings represents the total dry weight of the processed ore. Ore contains only about 0.1 percent uranium; therefore, the tailings consist of 99.9 percent of the ore, including all the radioactive decay products. The tailings discharge is composed of three fractions: (1) the sands, which consist of solids greater than 200 mesh (74 μm); (2) the slimes, which consist of solids less than 200-mesh; and (3) the liquid solution containing milling reagents and dissolved ore solids.

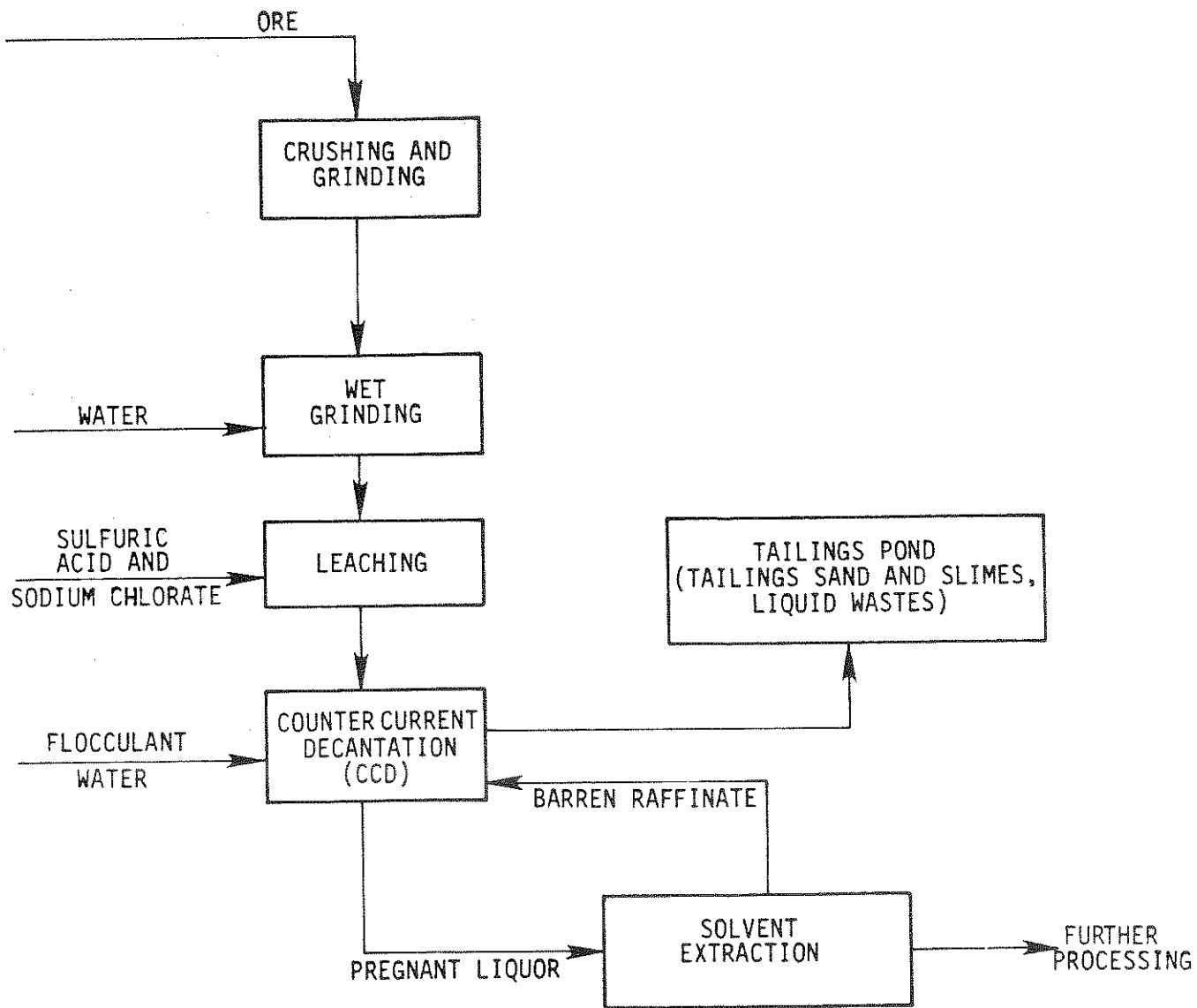

Figure 3-3. Simplified flow diagram of the acid leach process.

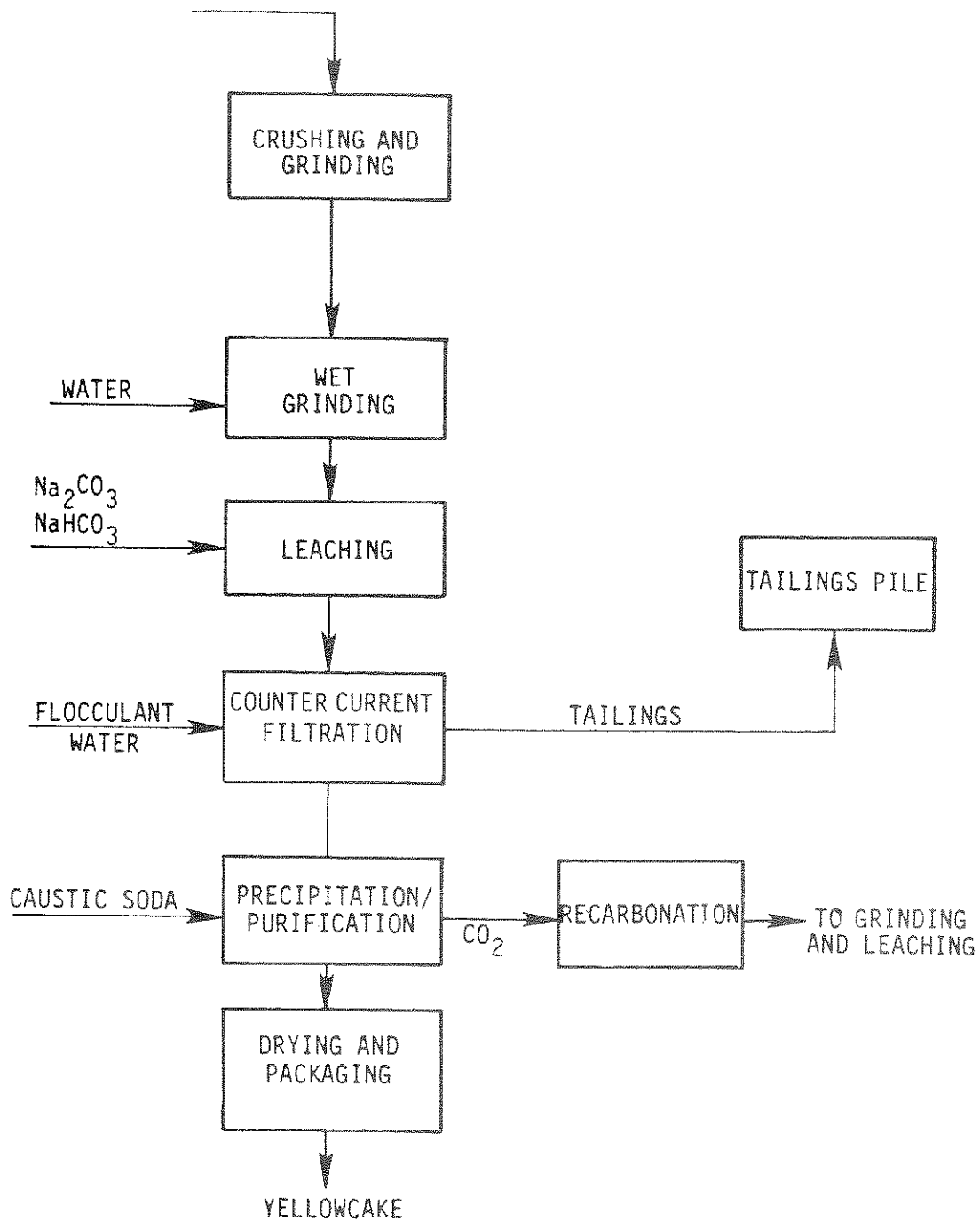

Figure 3-4. Simplified flow diagram of the alkaline leach-caustic precipitation process.

Dry tailings from an acid leach mill are typically composed of 20 to 37 percent slimes by weight (NRC80). Tailings are discharged from the mill as a slurry at an average ratio, by weight, of about 1:1 (solids to liquids) and are sent to an impoundment, where the tailings settle.

About 10 percent of the uranium-238 and virtually all of the other radionuclides in the ore are contained in the tailings. Tailings represent the largest and longest lasting source of radon-222 emissions from licensed conventional uranium mills because of the large exposed area and the significant concentrations of radium-226 present. The fine slimes fraction contains the majority of radium-226 in the tailings (up to 80 percent) (NRC80). The sands fraction contains radium-226 in concentrations ranging from 26 to 100 pCi/gram (NRC80), and the tailings liquid (raffinate) contains 1.7 to 35,000 pCi/liter of radium-226 and 50 to 250,000 pCi/liter of thorium-230 (EPA83).

The methods used to construct and fill tailings impoundments causes segregation of the slimes and sands. During spigoting, the sands are deposited on the perimeter of the impoundment and the slimes are carried to the central portions of the impoundment with the raffinate. The more porous sands are deposited away from the center of the pile and are therefore typically drier than the slimes, which are usually saturated with moisture of actually covered with standing process fluids.

Except for a small percentage used for backfill in underground mines, virtually all tailings are disposed of in impoundments. Disposal is below grade in mined-out or excavated pits and above grade behind dams. The majority of the tailing impoundments at licensed mills are above grade. Currently, new dams are constructed of earthen material, whereas in the past they were constructed of tailings sands. Impoundment sizes vary from 10 to about 121 ha (25 to 300 acres) (EPA85).

Site topography dictates the general shape of above-grade surface impoundments. One-sided, two-sided, and three-sided dams are constructed across valleys and along hillsides. Dams constructed on relatively flat terrain, where the tailings cannot be contained by the natural topography, are four-sided. Embankments are generally constructed of earthen material, but some (at six mills) are constructed of the sand fraction of the tailings.

The water level in a tailings impoundment is controlled through the use of decant towers, pumps, or siphons to recycle the water or to transfer it to evaporation ponds for proper maintenance of freeboard. Most mills operate with zero liquid discharge (40 CFR Part 440) and rely on evaporation.

Constructing impoundments with earthen embankments or below grade is the preferred method at new milling operations or for new impoundments at existing mills because they inherently have greater short-term and long-term stability. In addition, tailings disposed of below grade are typically covered with raffinate, which effectively controls dusting and reduces radon-222 emissions during the mill's active life.

Radon-222 is emitted from all exposed tailings in impoundments. Emission rates vary in different areas and over time. A qualitative illustration of the variation in radon-222 emissions over the life of a milling operation is shown in Figure 3-5. These emissions occur during the licensed phase of mill operations and continue for hundreds of thousands of years after closure of the mill. Radon-222 and radium-226 both have much shorter half-lives than their precursor thorium-230; therefore, their radioactivity remains the same as that for thorium-230 (EPA83). The radon-222 emissions decrease only as the thorium-230, which has a half life of 77,000 years, decreases (EPA83). It would require about 265,000 years for the radon-222 emissions to be reduced to 10 percent of its initial value (EPA83). If control techniques are not imposed, the radon-222 emissions will remain relatively constant, on a year-to-year basis for many tens of thousands of years.

3.4 Characterization of Emissions

The amount of radon-222 emitted from ore storage piles, milling circuits, evaporation ponds, and tailings impoundments depends on a number of highly variable factors, such as ore grade, emanation fraction, porosity, moisture, temperature, and barometric pressure. These factors, in turn, vary between milling sites, between locations on the same site, and with time (PEI85). These variations make it difficult to assess the radon-222 emission rate. For these reasons, mathematical models typically have been used to estimate average radon-222 emissions on a theoretical basis. A few systematic measurements have been made of radon-222 emissions from licensed uranium mills and tailings piles, and studies have demonstrated good agreement between actual measurements and estimates based on mathematical models (EPA83).

Considerable research has been conducted to develop and refine ways of calculating average radon-222 flux from infinitely thick or deep sources (i.e., at least 1 meter deep). This work has largely been carried out in support of the Uranium Mill Tailings Remedial Action Program (UMTRAP). Although these calculations were developed for inactive mill tailings piles, they are directly applicable to ore storage piles and tailings impoundments at licensed mills.

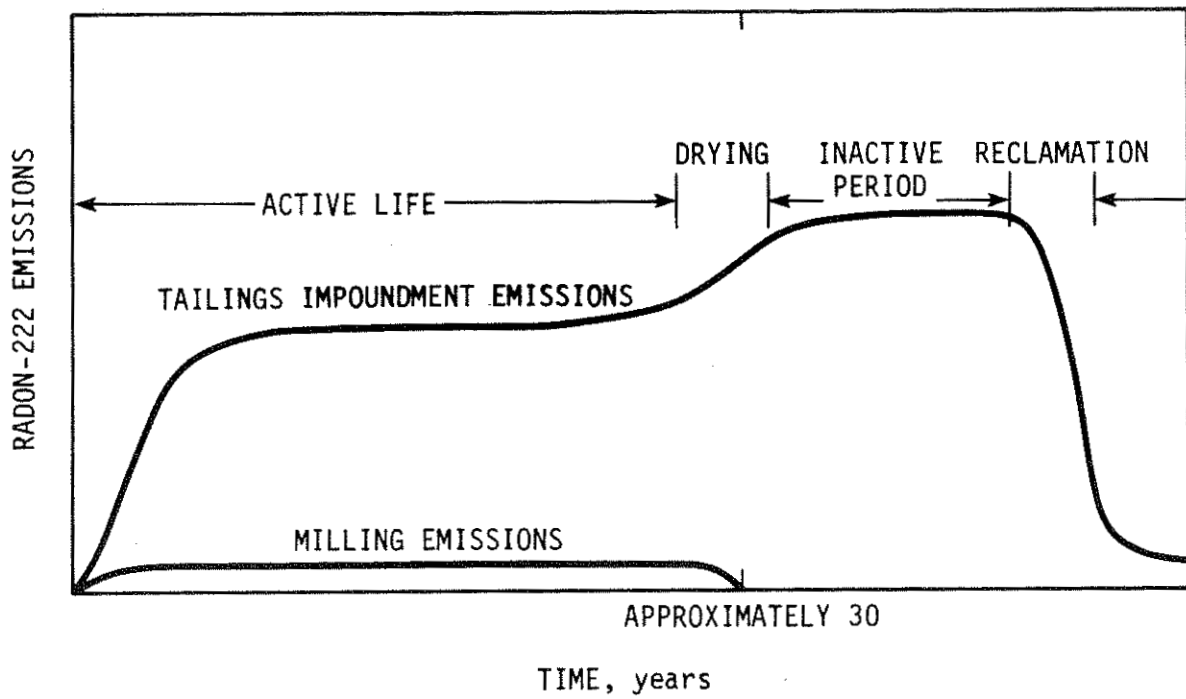

Figure 3-5. Qualitative illustration of radon-222 emissions from licensed uranium milling process.

A one-dimensional, steady-state, radon-222 diffusion equation has been developed for sources (e.g., ore piles and tailings) that are more than several meters thick (Ni82, Fr84). The equation is:

$$J_t = 10^4 R \rho E (\lambda D)^{1/2} \quad (3-1)$$

where J_t is the radon-222 flux at the surface of the source (pCi/m²s); R is the specific activity of radium-226 in ore or tailings equal to 2812 x uranium ore grade in percent (pCi/g); ρ is the bulk dry density of source (g/cm³); E is the radon-222 emanating fraction of source, dimensionless; λ is the radon-222 decay constant (2.1 x 10⁻⁶/s); D is the effective diffusion coefficient for radon-222, equal to bulk radon diffusion coefficient/porosity D_e/ρ (cm²/s); and ρ is the porosity, equal to 1-(bulk density/specific gravity).

For piles that are less than a few meters thick, Equation 3-1 should be multiplied by a hyperbolic tangent function that varies with depth or thickness (T), as shown in Figure 3-6. With the exception of the radon-222 decay constant, these parameters can vary significantly from location to location within the source, both horizontally and with depth, in a given ore pile or tailings impoundment. Except for the decay constant and bulk density, these parameters are difficult to measure. They are based on the physical characteristics of the source materials, which vary over time (e.g., radium-226 content may decrease over the life of the mill as ore grade declines), seasonally, or with changing mill operation (e.g., moisture content changes seasonally and with changes in mill operations and directly affects the emanation and diffusion coefficients).

A radon-222 release rate of 1 pCi Rn-222/m²s per pCi of Ra-226 per gram of tailings is used in this background report because of emission rate variations and the lack of specific information required to use the more detailed mathematical equations (NRC80) (Ha85). Using an average, specific flux does not take into account site-specific conditions such as moisture, porosity, and emanation coefficients. It is useful for estimating industry-wide emissions, however, and is consistent with previous EPA studies (EPA83). In the following sections, a model mill handling 1800 t/day of ore with 0.1 percent U₃O₈ will be used to illustrate radon-222 emission calculations. Assumptions are made for the parameters required to calculate emissions with the diffusion equations, and for comparison a specific flux of 1 pCi Rn-222/m²s per pCi of Ra-226/g is also used to estimate emissions.

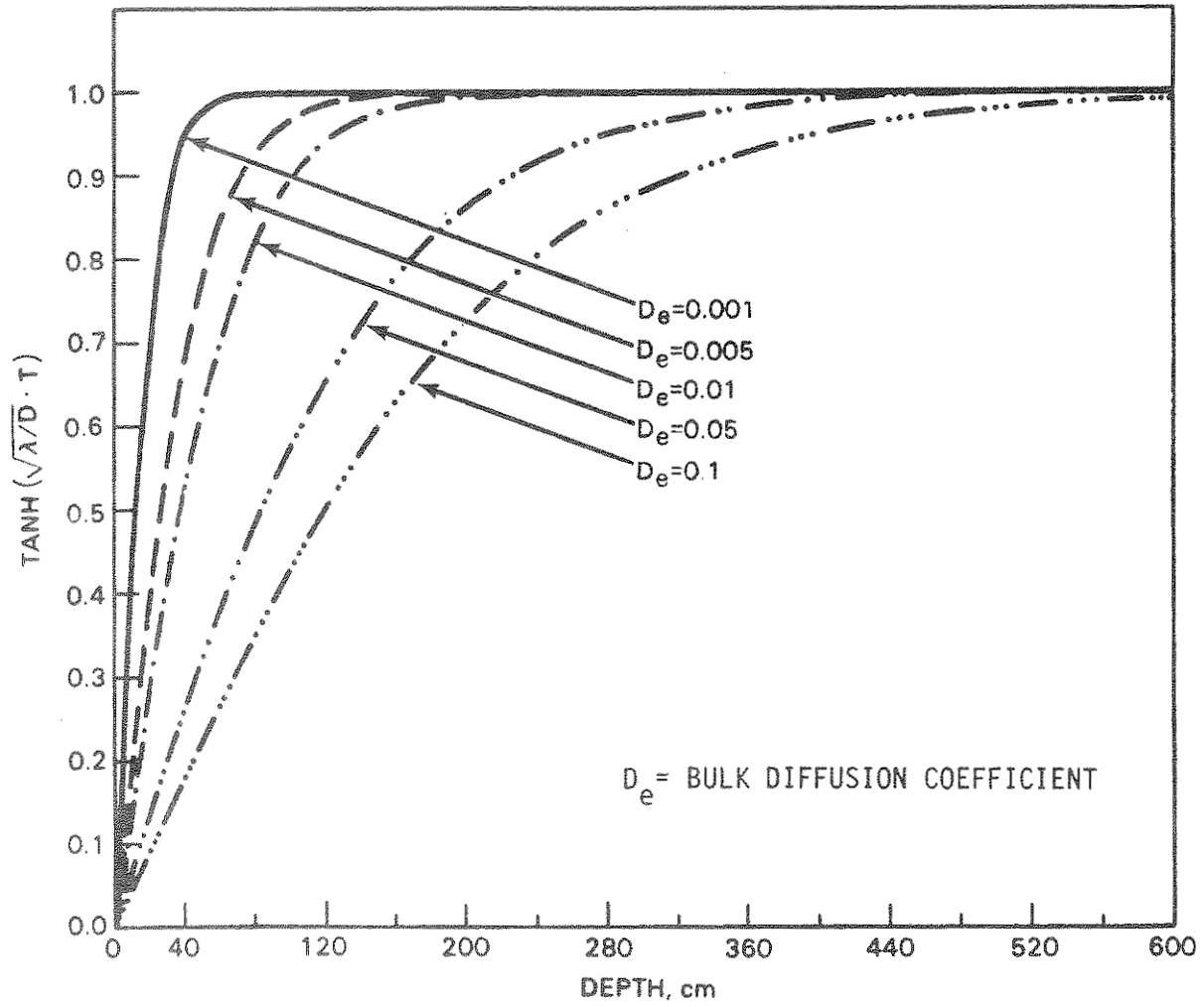

Figure 3-6. Effect of ore pile depth on hyperbolic tangent term in radon-222 flux equation (Ha85).

3.4.1 Ore Handling and Preparation

Stockpiles are blended to the average or optimum feed grade upon entry to the mill. Emissions can be based on the average radium-226 content, as both the initial total radon-222 release and the longer-term, diffusion-controlled radon-222 releases vary linearly with radium-226 content. The radium-226 content is typically estimated from ore grades, assuming secular equilibrium between the uranium-238 and the radium-226.

Ore storage piles are typically more than 3 meters deep. Thus, Equation 3-1 can be used to estimate radon-222 emissions if the various values are known, or a specific flux of 1 pCi Rn-222/m s per pCi Ra-226 per gram of ore can be used.

As an example, consider the ore pad at a hypothetical mill with the following parameters:

$$\begin{aligned} A &= \text{area of ore pile} = 6 \text{ acres or } 2.4 \times 10^4 \text{ m}^2 \\ T &= \text{depth of ore pile} = 3 \text{ m minimum} \\ R &= \text{Ra-226 concentration} = 2812 \times 0.1 \text{ U}_3\text{O}_8 = \\ & 281 \text{ pCi/g} \\ E &= \text{emanating power of ore} = 0.2 \\ \rho &= \text{density} = 1.6 \text{ g/cm}^3 \\ D &= \text{diffusion coefficient} = 0.05 \text{ cm}^2/\text{s} \\ J &= 10^4 R \rho E (\lambda D)^{1/2} \\ &= 281 \times 0.2 \times 1.6 (2.1 \times 10^{-6} \times 0.05)^{1/2} \times \\ & 10^4 \text{ cm}^2/\text{m}^2 \\ &= 291 \text{ pCi Rn-222/m}^2 \text{ s} \end{aligned}$$

The ore pad would have the following calculated radon-222 emissions:

$$\begin{aligned} & 291 \text{ pCi Rn-222/m}^2 \times 2.4 \times 10^4 \text{ m}^2 \times 3.156 \times \\ & 10^7 \text{ s/y} \times 10^{-12} \text{ Ci/pCi} = 221 \text{ Ci/y} \end{aligned}$$

Or if a specific flux of 1 pCi Rn-222/m²s per pCi Ra-226 is assumed, the estimated emissions are:

$$\begin{aligned}
 & 1 \text{ pCi Rn-222/m}^2\text{s/pCi Ra-226/g} \times 281 \text{ pCi Ra-226/g} \times \\
 & 2.4 \times 10^4 \text{ m}^2 \times 3.156 \times 10^7 \text{ s/y} \times 10^{-12} \text{ Ci/pCi} = \\
 & 213 \text{ Ci/y}
 \end{aligned}$$

3.4.2 Mill Emissions

The throughput is relatively large (several thousand tons per day); therefore, the residence time of ore in the mill is less than one day. This short residence time means that little new radon-222 is formed in the milling operation. Hence, the ore does not release large quantities of radon-222 in the mill circuit unless the radon-222 that previously emanated from the ore was not released completely during storage, handling, and crushing and grinding.

Most milling emissions of radon-222 occur during the transferring and dumping of the ore into the mill feed area because the ore has usually been reduced to sizes of less than 40 cm, which allow trapped radon-222 to escape. Emissions from dumping, crushing, and grinding can be estimated by assuming 10 percent of the radon is released, as shown here:

$$\begin{aligned}
 & 1800 \text{ t/day} \times 310 \text{ days/y} \times 281 \text{ pCi/g} \times 10^6 \text{ g/t} \times \\
 & 10^{-12} \text{ Ci/pCi} \times 0.1 = 16 \text{ Ci/y}
 \end{aligned}$$

Alternatively, an average emission factor of 3.8×10^7 pCi/lb U₃O₈ may be used to estimate Rn-222 emissions from milling (PEI85).

$$\begin{aligned}
 & 1800 \text{ t/day} \times 310 \text{ days/y} \times 2200 \text{ lb/t} \times 0.001 \text{ lb} \\
 & \text{U}_3\text{O}_8/\text{lb ore} \times 3.8 \times 10^7 \text{ pCi/lb U}_3\text{O}_8 \times \\
 & 10^{-12} \text{ Ci/pCi} = 47 \text{ Ci/y}
 \end{aligned}$$

Radon-222 emissions from the leaching and extraction processes of the mill circuit are very low because these are wet processes and most of the radon-222 in the ore was already released during storage and handling prior to milling. Emissions from packaging the yellowcake product are also low, as very little (less than 0.1 percent) of the radium-226 that produces the radon-222 remains in the yellowcake.

3.4.3 Emissions From Tailings Disposal

The large area occupied by tailings impoundments and the extent of the exposed surface area make these impoundments the major potential source of radon-222. Tailings include the barren crushed ore material plus process solutions. These tailings consist of mixtures of sand and slimes (coarse and fine tailings). Evaporation ponds used to contain excess liquid from tailings impoundments also contain suspended and dissolved tailings and are included in this analysis. The size of these ponds was documented in a recent report (EPA85). Tailings solids are assumed to be carried with the process liquids and deposited on the bottoms of these ponds. If exposed, these solids are assumed to emit radon-222 at the same specific flux as tailings impoundments.

The procedure for estimating radon-222 emissions will depend on the amount of site-specific information available. If site-specific information on the radium-226 concentration, moisture content, porosity, density, and emanating power are known, the diffusion equation to estimate radon-222 flux may be used. Where specific information is not available, a simplified relationship of 1 pCi Rn-222/m s per pCi Ra-226/g of tailings may be used to estimate emissions from dry areas of tailings impoundments (wet and ponded areas are not assumed to emit radon-222). An example of the calculation used to estimate radon-222 emissions from tailings by both calculation procedures is presented here for a 50-ha (120-acre) impoundment. Of the total area, 50 percent consists of saturated or liquid-covered tailings and 50 percent is dry. The tailings solids in the impoundment are 10 m (30 ft) deep.

Emission estimates made by using diffusion Equation 3-1

$$\text{Radon-222 flux } J = 10^4 R \rho E (\lambda D)^{1/2}$$

R = 281 pCi Ra-226/g of tailings

E = 0.2 (based on measurement; varies from ~0.1 to ~0.4)

ρ = density = 1.6 gm/cm³

λ = 2.1 x 10⁻⁶/s

D = diffusion coefficient for tailings

$$= 0.07 \exp(4mp^2 - 4m - 4m^5)$$

where m is the moisture saturation fraction (~0.35), p is the porosity (1- ρ /g), and g is the specific gravity (~2.7 g/cm³).

Thus:

$$\begin{aligned} p &= 1 - 1.6/2.7 = 0.407 \\ D &= 0.07 \exp [4 \times 0.35 \times (0.407)^2 - 4 \times \\ &\quad 0.35 - 4 \times (0.35)^5] \\ &= 0.0213 \text{ cm}^2/\text{s} \\ J &= 281 \times 0.2 \times 1.6 (2.1 \times 10^{-6} \times \\ &\quad 0.0213)^{1/2} \times 10^4 \text{ cm}^2/\text{m}^2 \\ &= 190 \text{ pCi}/\text{m}^2 \text{ s} \end{aligned}$$

Total annual emissions are determined by multiplying J by the dry area and seconds per year.

$$\begin{aligned} \text{Rn-222} &= 190 \text{ pCi}/\text{m}^2 \text{ s} \times 25 \times 10^4 \text{ m}^2 \times 3.156 \times \\ &\quad 10^7 \text{ s}/\text{y} \times 10^{-12} \text{ Ci}/\text{pCi} \\ &= 1505 \text{ Ci}/\text{y} = \sim 1.5 \text{ kCi}/\text{y} \end{aligned}$$

Emissions estimate based on specific flux of
1 pCi Rn-222/m²s per pCi Ra-226/g

$$\begin{aligned} \text{Rn-222} &= 1 \text{ pCi Rn-222}/\text{m}^2 \text{ s}/\text{pCi Ra-226}/\text{g} \times 281 \\ &\quad \text{pCi Ra-226}/\text{g} \times 25 \times 10^4 \text{ m}^2 \times 3.156 \times \\ &\quad 10^7 \text{ s}/\text{y} \times 10^{-12} \text{ Ci}/\text{pCi} \\ &= 2223 \text{ Ci}/\text{y} = \sim 2.2 \text{ kCi}/\text{y} \end{aligned}$$

The simplified calculation based on a specific flux of 1 pCi Rn-222/m²s per pCi Ra-226/g yields a similar but higher emission estimate in this example case.

In almost all cases, the tailings impoundments are by far the largest source of radon-222 emissions. For mills on standby, the tailings impoundments account for practically all the radon-222 emissions. The tailings impoundment, which is the most significant source of radon-222 emissions from the mill site, accounts for about 80 percent of the total radon-222 emissions at an active licensed mill and practically 100 percent at an inactive or standby licensed mill.

3.5 Transport and Risk Assessment

Two separate steps are required to estimate the health impact of a specific source of radon-222: (1) determining its dispersion and estimating, at various locations, its concentration and the corresponding exposure to its decay products in units of WLM and (2) calculating the risk.

3.5.1 Air Dispersion Estimates

EPA uses the AIRDOS-EPA code (Mo79, Ba81) to analyze the transport of radionuclide emissions into air from a specific source. This analysis estimates radionuclide concentrations in air at various distances from the source.

The AIRDOS-EPA code uses a modified Gaussian plume equation to estimate airborne dispersion. Calculations are site-specific and require the joint frequency distribution of wind direction, windspeed, and atmospheric stability. The accuracy of these projections decreases with distance; therefore, calculations with this method are limited to regional areas (e.g., less than 80 km from the source). The values calculated represent annual averages because diurnal or seasonal variations are included in the joint frequency distribution. Calculations of working-level exposures for the inhalation of radon-222 progeny are then made based on estimates of radon-222 concentrations in air.

Radon-222 emitted from tailings impoundments can be transported beyond the 80-km regional area. Results from a trajectory dispersion model developed by the National Oceanic and Atmospheric Administration (Tr79) were used to estimate the national impact of radon-222 emissions. The model yields radon-222 concentrations in the air (in picocuries/ liter), which are converted to decay product concentrations and expressed in terms of working levels.

3.5.2 Risk Estimates

After the exposure to radon-222 decay products has been estimated in terms of working level months for a specific source by means of the environmental transport code, the risk of fatal lung cancer is calculated using the risk factors discussed in Chapter 2. The risk is scaled up to the total population risk by multiplying by the population exposed to that working level over a lifetime.

3.6 Measurement of Radon-222

Although all radon-222 emission levels in this report represent calculated estimates, it is possible to make direct measurements on specific sources. Radon-222 measurement methodologies are discussed in the following subsections. Ambient samplers are generally used to measure radon-222 emissions; however, some concentrating samplers are also used. The latter operate in a grab or continuous mode and sample radon-222 as it emanates from a source. Ambient gas samplers measure the accumulation of radon-222 present in the ambient air and typically have short sample collection periods (i.e., minutes). Concentrating samplers use a medium such as activated charcoal to adsorb radon-222. Sample collection periods for concentrating samplers are typically 24 to 72 hours.

3.6.1 Ambient Air Samplers

The most common type of ambient air sampler for the collection of radon-222 grab samples is the accumulator can. Accumulator can design and construction vary widely; however, all accumulator cans are constructed with an open-ended container fitted with a sampling port for periodic withdrawal of radon-222 air samples. During collection of a radon-222 sample, the open end of the container is sealed to the sample medium (e.g., tailings) by simple insertion, caulking, or the use of permanent fixtures. After an adequate length of time (on the order of minutes) has been allowed for the radon-222 to accumulate in the container, a fixed air volume is withdrawn from the container through the sampling port and the alpha activity is counted.

Another type of ambient sampler, which operates continuously rather than collecting grab samples, uses the same sampling procedure as the accumulator can except air is pumped through the can at a rate equivalent to one air volume per sampling period. The air is pumped through a filtered inlet to a calibrated scintillation cell and alpha activity is counted continuously.

3.6.2 Concentrating Samplers That Measure Radon-222 Emanation From Surfaces

There are two types of concentrating samplers equipped with activated charcoal to adsorb radon-222. These include the passive charcoal canister samplers and the active, circulating-air test sampler. The charcoal canisters, which are available in a variety of sizes, are placed directly on the soil or tailings surface, exposed for 24 to 72 hours, and use activated charcoal as the concentrating medium. Their physical dimensions and the quantity of charcoal used to collect a radon-222 sample vary widely (Ni84).

Selection of a specific charcoal sampler depends on the particular application. Large-area samplers (e.g., greater than 1000 cm²) improve the representativeness of the sample by sampling a larger area, but small samplers are more economical and logistically simpler.

The circulating-air test sampler covers a much larger area than the canisters (i.e., 9290 cm² (Ni84)). It is a continuous, active sampler in which air is circulated across the soil or tailings surface enclosed by the sampler, and continues through a section of corrugated tubing containing the activated charcoal. The tubing is sectioned into two halves, which allows for the detection of any carryover. The sampler is typically operated for 24 hours at a flow rate of about 2 liters per minute. The circulating-air test sampler is a cumbersome technique and is less effective than charcoal canisters considering cost and labor (Yo83).

Activated charcoal used for the collection of radon-222 is sealed in an air-tight container and set aside for a few hours to allow the short-lived radon daughters to come to equilibrium (Yo83). The amount of radon adsorbed by the activated charcoal (no matter which concentrating sampler is used) is quantified by gamma-ray spectroscopy of the charcoal using a NaI(Tl) crystal or germanium diode and multichannel analyzer. Typically the Bismuth-214 609-keV peak is used to determine radon-222 activity, but other Bismuth-214 or Lead-214 peaks could be used.

REFERENCES

- Ba81 Baes C. F. III and Sharp R. D., "A Directory of Parameters Used in a Series of Assessment Applications of the AIRDOS-EPA and DARTAB Computer Codes", ORNL-5720, Oak Ridge National Laboratory, Oak Ridge, Tennessee, March 1981.
- EPA79 U.S. Environmental Protection Agency, "Indoor Radiation Exposure Due to Radium-226 in Florida Phosphate Lands", EPA 520/4-78-013, Office of Radiation Programs, U.S. EPA, Washington, D.C., July 1979.
- EPA83 U.S. Environmental Protection Agency, "Final Environmental Impact Statement for Standards for the Control of Byproduct Material From Uranium Ore Processing", EPA 520/1-83-008-1, Office of Radiation Programs, U.S. EPA, Washington, D.C., September 1983.
- EPA85 U.S. Environmental Protection Agency, "Draft Document-Estimates of Population Distributions and Tailings Areas Around Licensed Uranium Mill Sites", Office of Radiation Programs, U.S. EPA, Washington, D.C., November 1985.
- Fr84 Freeman H. D., and Hartley J. N., "Predicting Radon Flux From Uranium Mill Tailings", in: Sixth Symposium on Uranium Mill Tailings Management, Fort Collins, Colorado, February 1-3, 1984.
- Ha85 Hartley J. N., Glissmeyer J. A., and Hill O. F., "Methods for Estimating Radioactive and Toxic Airborne Source Terms for Uranium Milling Operations", PNL for U.S. Nuclear Regulatory Commission, Washington, D.C., NUREG/CR-4088 June 1985.
- Me71 Merritt, R. C., "The Extractive Metallurgy of Uranium", prepared under contract with the United States Atomic Energy Commission, 1971.
- Mo79 Moore R. E., Baes C. F. III, McDowell-Boyer L. M., Watson A. P., Hoffman F. O., Pleasant J. C., and Miller C. W., "AIRDOS-EPA: A Computerized Methodology for Estimating Environmental Concentrations and Dose to Man From Airborne Releases of Radionuclides", EPA 520/1-79-009, Office of Radiation Programs, U.S. EPA, Washington, D.C., December 1979.

- Ni82 Nielson K. K., et al., "Radon Emanation Characteristics of Uranium Mill Tailings", in: Symposium on Uranium Mill Tailings Management, Fort Collins, Colorado, December 9-10, 1982.
- Ni84 Neilson K. K. and Rogers V. C., "Radon Flux Measurement Methodologies. Management of Uranium Mill Tailings, Low-Level Waste and Hazardous Waste", in: Proceedings of the Sixth Symposium, Colorado State University, Fort Collins, Colorado, February 1-3, 1984.
- NRC80 Nuclear Regulatory Commission, "Final Generic Environmental Impact Statement on Uranium Milling", NUREG-0706, September 1980.
- NRC81 Nuclear Regulatory Commission, "MILDOS - A Computer Program for Calculating Environmental Radiation Doses From Uranium Recovery Operations", NUREG/CR-2011, PNL-3767, prepared by Pacific Northwest Laboratory, Battelle Memorial Institute for the U.S. Nuclear Regulatory Commission, April 1981.
- PEI85 PEI Associates, Inc., "Radon-222 Emissions and Control Practices for Licensed Uranium Mills and Their Associated Tailings Piles", prepared for U.S. Environmental Protection Agency, Office of Radiation Programs, June 1985 (revised November 1985).
- Th82 Thomas V. W., Nielson K. K., and Mauch M. L., "Radon and Aerosol Release From Open Pit Uranium Mining", NUREG/CR-2407, Nuclear Regulatory Commission, 1982.
- Tr79 Travis C. C., Watson A. P., McDowell-Boyer L. M., Cotter S. J., Randolph M. L., and Fiedls D. E., A "Radiological Assessment of Radon-222 Released From Uranium Mills and Other Natural and Technologically Enhanced Sources", ORNL/NUREG-55, Oak Ridge National Laboratory, Oak Ridge, Tennessee, 1979.
- Yo83 Young J. A., et al. "Recommended Procedures for Measuring Radon Fluxes From Disposal Sites of Residual Radioactive Materials", NUREG/CR-3166, PNL-4597, March 1983.

Chapter 4: INDUSTRY DESCRIPTION

4.1 Overview

In January 1986, the conventional uranium milling industry in the United States consisted of 26 licensed facilities. Three additional mills have been licensed, but either have never been constructed or have never operated. Only 4 of the 26 licensed facilities were operating; 16 were on standby status, and 6 were being or have been decommissioned. The mills on standby status are being maintained, but they are not processing uranium ore. When the demand for uranium increases, these standby mills could resume milling. The decommissioned mills have been dismantled and have been removed off site or disposed of on site; therefore, these mills will never resume operations. Their associated tailings impoundments are either being reclaimed or there are plans to reclaim them. The current operational status and capacity of each licensed conventional mill are shown in Table 4-1.

The Secretary of Energy has determined that the domestic uranium mining and milling industries were not viable in 1984 (ELP85). In 1984, the annual domestic uranium production was the lowest since the mid-1950's, and employment was down 75 percent from 1981 to 1984 (ELP85).

4.2 Site-Specific Characteristics

The licensed conventional uranium mills are in Colorado, New Mexico, South Dakota, Texas, Utah, Washington, and Wyoming. Their approximate locations are shown in Figure 4-1. Brief, site-specific summaries of all the active or standby conventional uranium mills were prepared as part of this document and are presented in this section. As described in Chapter 3, the tailings disposal operations represent the largest source of radon-222 emissions; therefore, the summaries focus largely on these operations.

The site summaries were compiled from data contained in other EPA, NRC, and DOE documents. A recent EPA report (EPA85) entitled "Estimates of Population Distributions and Tailings Areas Around Licensed Uranium Mill Sites" was the source of the measurements of the surface areas of impoundments. The populations in the 0- to 5-km range around the tailings impoundments were taken from a 1984 survey that Battelle

Table 4-1. Operating status and capacity of licensed conventional uranium mills as of August 4, 1986^(a)

State	Mill	Owner	Operating status ^(b)	Operating capacity (tons/day) ^(c)
Colorado	Canon City	Cotter Corp.	Standby	1200
	Uravan	Umetco Minerals	Standby	1300
New Mexico	L-Bar	Sohio/Kennecott	Decommissioning ^(d)	1650
	Churchrock	United Nuclear	Decommissioning ^(d)	4000
	Bluewater	Anaconda	Decommissioning ^(d)	6000
	Quivira	Kerr-McGee	Standby ^(e)	7000
	Grants	Homestake	Active ^(e)	3400
South Dakota	Edgemont	TVA	Decommissioned	---
Texas	Panna Maria	Chevron	Active	2600
	Conquista	Conoco/Pioneer	Decommissioned	---
	Ray Point	Exxon	Decommissioned	---
Utah	White Mesa	Umetco Minerals	Active ^(f)	2000
	La Sal	Rio Algom	Active ^(g)	750
	Moab	Atlas	Standby	1400
	Shootaring Canyon	Plateau Resources	Standby	800
Washington	Ford	Dawn Mining	Standby	600
	Sherwood	Western Nuclear	Standby	2000

Table 4-1. Operating status and capacity of licensed conventional uranium mills as of August 4, 1986 (a) (continued)

State	Mill	Owner	Operating status (b)	Operating capacity (tons/day) (c)	
Wyoming	Highland Gas Hills	Exxon American Nuclear Corp.	Decommissioned	--	
			Decommissioned	--	
	Shirley Basin Gas Hills	Petrochemicals Pathfinder	Decommissioned	--	
			Standby	2500	
	Split Rock Gas Hills	Western Nuclear Umetco Minerals	Standby	1700	
			Standby	1400	
	Bear Creek Shirley Basin Sweetwater	Rocky Mt. Energy Pathfinder Minerals Exploration	Decommissioning (d)	2000	
			Active	1800	
	Total			Standby	3000
				5 Active 11 Standby 10 Decommissioned or intend to decommission	

(a) Data obtained from conversations with Agreement States, NRC representatives, and mill operators. Does not include mills licensed but not constructed.

(b) Active mills are currently processing ore and producing yellowcake. Standby mills are not currently processing ore, but are capable of restarting. The mill structure has been dismantled at decommissioned mills and tailings piles are currently undergoing reclamation or will be.

(c) Tons indicates short tons equal to 2000 lbs.

(d) Submitted letter of intent to decommission.

(e) Operating only a few days each month.

(f) Current contract will allow operation for 12-18 months.

(g) Likely to go to standby status.

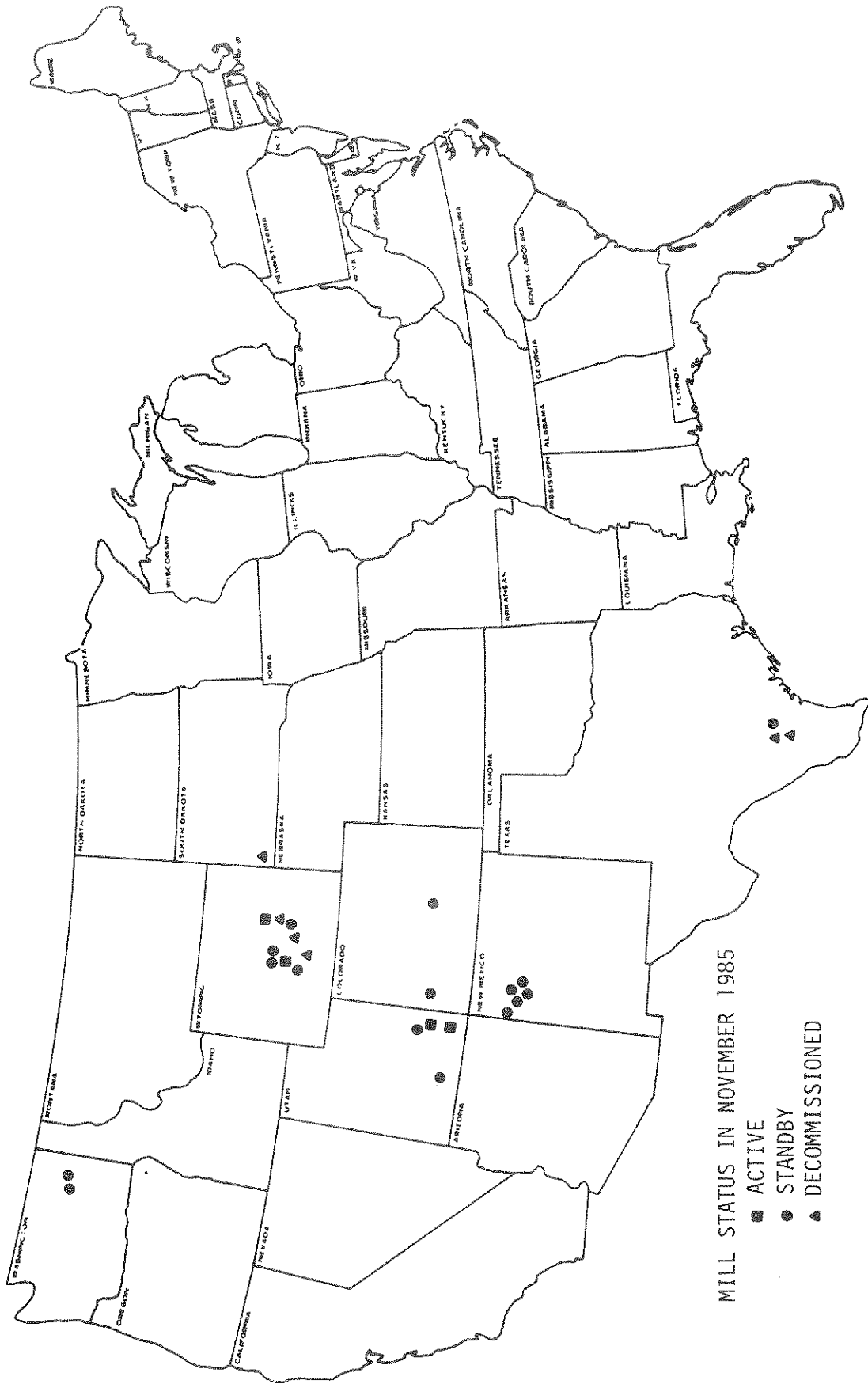

Figure 4-1. Approximate locations of licensed conventional uranium mills.

Memorial Institute conducted for the EPA (PNL84). In addition, color aerial photographs of each active and standby mill site were provided by the Office of Radiation Programs to augment the available data base (EPA85).

A summary of current conditions and the extent of tailings impoundments and evaporation ponds at these sites is presented in Table 4-2. Diagrams of each mill site are included in Appendix A. Additional details regarding these mills and the impoundments are provided in the following text under the appropriate state.

4.2.1 Colorado

The two licensed uranium mills located in Colorado are operated by Cotter Corporation and Umetco Minerals (Union Carbide) in Canon City and Uravan (see Figure 4-2). A third mill, Pioneer Nuclear's proposed San Miguel mill in San Miguel County, was licensed but never constructed. The license for this mill is under litigation (NRC84).

Canon City Mill

The Cotter Corporation, a subsidiary of Commonwealth Edison, operates a two-stage acid leach mill at Canon City, Colorado, which recovers uranium and vanadium. A small alkaline leach mill also was operated on this site from 1968 until its decommissioning in 1979. The existing mill, which began operations in September 1979, has a capacity of 1200 tons of ore per day. The ore grade ranges between 0.23 and 0.35 percent U_3O_8 (NRC84). The mill has been on standby status since February 1985.

Tailings generated since September 1979 have been placed in an above-grade clay- and membrane-lined impoundment that covers 34 ha (84 acres) and has earthen embankments (EPA85). Plans call for the dam to be raised to its ultimate height of 35 m (115 feet) in one additional stage. The tailings solution currently covers 31 ha (77 acres) and varies in depth from less than 0.3 to more than 6 m (<1 to >20 feet) (EPA85, Mc85). Currently, the area of exposed tailings beach covers 3 ha (7 acres), of which 1.8 ha (4.5 acres) is dry (EPA85). The tailings discharge into the pond is moved along the perimeter during operations to keep the tailings wet and evenly distributed. This impoundment now contains 0.9×10^6 tons of tailings and has a capacity of 14×10^6 tons (NRC84). The tailings are reported to contain 780 pCi/g of radium-226 (EPA83a).

Table 4-2. Summary of current uranium mill tailings impoundment areas and radium-226 content

Owner/Impoundment	Type of impoundment (a)	Status (b)	(c) Surface area (acres)				Average Ra-226 (d) pCi/g
			Total	Ponded	Wet	Dry	
<u>Colorado</u>							
Cotter Corp.							
Primary	2/SL	S	84	77	3	4	780
Secondary	2/SL	C	31	1	1	30	780
Umetco							
Uravan 1 & 2	1	C	66	0	4	62	480
Uravan 3	1	C	32	0	3	29	480
Sludge pile	1	C	20	0	1	19	480
Evap. pond	1	C	17	0	2	15	480
<u>New Mexico</u>							
Sohio							
L-Bar	1	S	128	28	55	45	500
United Nuclear							
Churchrock	1	S	148	7	76	65	290
Anaconda							
Bluewater 1	2	S	239	0	0	239	620
Bluewater 2	2	C	47	0	0	47	620
Bluewater 3	2	C	24	0	0	24	620
Evap. ponds	2	S	162	97	17	48	620
Kerr-McGee							
Quivira 1	1	S	269	14	64	191	620
Quivira 2a	1	S	105	10	35	60	620
Quivira 2b	1	S	28	0	3	25	620
Quivira 2c	1	S	30	0	4	26	620
Evap. ponds	2	S	372	268	10	95	620

Table 4-2. Summary of current uranium mill tailings impoundment areas and radium-226 content (continued)

Owner/Impoundment	Type of impoundment (a)	Status (b)	Surface area (acres) (c)				Average Ra-226 (d) pCi/g)
			Total	Ponded	Wet	Dry	
<u>Homestake</u>							
Homestake 1	1	S	205	63	33	109	385
Homestake 2	2	C	44	4	0	36	385
<u>Texas</u>							
<u>Chevron</u>							
Panna Maria	2	S	124	68	20	36	196
<u>Utah</u>							
<u>Umetco</u>							
White Mesa 1	3/SL	A	48	7	7	34	350
White Mesa 2	3/SL	A	61	10	6	45	350
White Mesa 3	3/SL	A	53	39	0	14	350
<u>Rio Algom</u>							
Rio Algom 1	2	A	44	4	2	38	560
Rio Algom 2	2	A	32	12	5	15	560
<u>Atlas</u>							
Moab	1	S	147	54	4	90	540
<u>Plateau Resources</u>							
Shootaring	2	S	7	2	1	4	280
<u>Washington</u>							
<u>Dawn Mining</u>							
Ford 1,2,3	2	C	95	0	0	95	240(e)
Ford 4	3/SL	S	28	17	0	11	240(e)

4-7

Table 4-2. Summary of current uranium mill tailings impoundment areas and radium-226 content (continued)

Owner/Impoundment	Type of impoundment (a)	Status (b)	Surface area (acres)		Average Ra-226 (d) pCi/g		
			Total	(c) Ponded Wet Dry			
Western Nuclear Sherwood Evap. pond	2/SL 2/SL	S S	94 16	18 16	70 0	200 200	
<u>Wyoming</u> Pathfinder Gas Hills 1 Gas Hills 2 Gas Hills 3 Gas Hills 4	2 2 2 2	S C S S	124 54 22 89	2 2 19 73	3 12 2 4	119 40 2 11	420 420 420 420
Western Nuclear Split Rock	2	S	156	94	19	43	430
Umetco Gas Hills A-9 Pit Leach pile Evap. ponds	2 3/CL 2 2	C S S S	151 25 22 20	0 2 0 20	0 9 0 0	151 14 22 0	310 310 310 310
Rocky Mountain Energy Bear Creek	2	A	121	45	23	53	420
Pathfinder Shirley Basin	2	A	261	179	22	60	540

Table 4-2. Summary of current uranium mill tailings impoundment areas and radium-226 content (continued)

Owner/Impoundment	Type of impoundment (a)	Status (b)	Surface area (acres) (c)				Average Ra-226 (d) pCi/g)
			Total	Ponded	Wet	Dry	
Minerals Exploration Sweetwater	2/SL	S	37	30	0	7	280
Totals			3882	1282	457	2140	-

(a) Type of impoundment; 1 = dam constructed of coarse tailings; 2 = earthen dam; 3 = below grade; SL = synthetic liner; CL = clay liner.

(b) Status of impoundment; A = active; S = standby (will be used when operations resume); C = filled to capacity (will not be used again).

(c) Source: EPA85

(d) Source: EPA83

(e) Source: EPA86

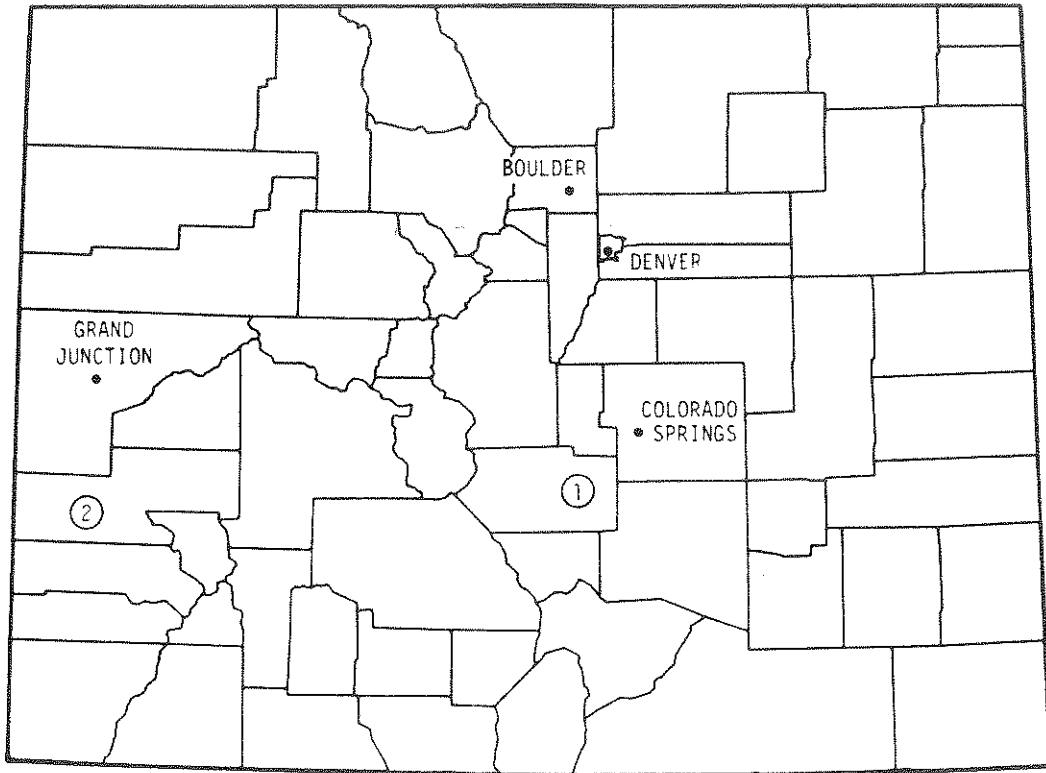

① Cotter Corp.
Canon City Mill

② Umetco Minerals
Uravan Mill

Figure 4-2. Location of mills in Colorado.

A 12-ha (31-acre) secondary impoundment containing 1.5×10^6 tons commingled tailings (defense-related tailings generated under Atomic Energy Commission contracts commingled with tailings generated under commercial contracts) generated in pre-1979 operations has been constructed adjacent to the main impoundment. Approximately 0.4 ha (1 acre) is covered with ponded solution, 0.4 ha (1 acre) consists of exposed saturated tailings, and about 12 ha (30 acres) are dry (EPA85). These impoundments are actually two cells of one large impoundment. The secondary impoundment also is used for disposal of nontailings solid waste generated on site and will be used for disposal of decommissioning waste during closure operations (DOE82). The old tailings have not been covered, but they have been furrowed to control dusting. The costs for constructing the main and secondary impoundments were \$15,800,000 and \$7,200,000, respectively (DOE82).

Canon City is located about 3.2 km (2 mi) north of the mill site. The area immediately surrounding the mill site is unpopulated, and the land is used primarily for livestock grazing (DOE82). The nearest residents are 184 people who live between 2 and 3 km (1.2 and 1.9 mi) from the impoundment (PNL84). A 1983 survey indicated 5933 people lived within 5 km (3.1 mi) of the tailings impoundment (PNL84).

The climate in the area is semiarid and temperate; average annual precipitation is 30 cm (12 in.) (DOE82). Windspeeds are variable, with a mean of 13 km/h (8 mi/h) (DOE82).

Uravan Mill

Umetco Mineral's uranium mill in Uravan, Colorado, an area of rugged canyons and mesas, is 80 km (50 mi) south of Grand Junction. Uranium, vanadium, and radium-226 recovery operations were begun at this site in 1915. The mill has been on standby status since November 1984 and will likely be on standby for at least 2 years and possibly permanently (Kr85). The existing tailings disposal facilities have reached their maximum capacity, and a new disposal area must be planned and approved before mill operations are restarted (Kr85). The capacity of this mill is 1300 tons of ore per day.

The mill uses a hot, highly oxidizing, two-stage acid leach to recover uranium and vanadium. During milling operations, ore has been received from more than 200 mines in the Uravan mineral belt. Tailings have been generated under AEC, Army, and commercial contracts and have been commingled and disposed of on site. The impoundments contain an estimated 10×10^6 tons of tailings. These tailings impoundments are situated on mesas

above Uravan. Impoundments 1 and 2 are adjacent and overlapping and actually constitute just one impoundment. The impoundments are constructed behind dikes of coarse tailings on the outward face and contained by the native terrain on the inward side. Tailings were discharged to the impoundments from spigots situated around the berm. Gravity settling deposited the sands near the dike, and slimes were carried to the interior with the tailings solution.

Impoundments 1 and 2 cover a combined area of 27 ha (66 acres) and have a maximum dam height of 46 m (155 ft) (EPA85, DOE82). Impoundment 3 covers 13 ha (32 acres), and the dike is about 33 m (110 ft) high. Eight other impoundments, which either contain tailings or have been constructed of tailings, were mainly used for evaporation. These eight impoundments cover 15 ha (37 acres). The radium-226 content of the Uravan tailings has been reported to be 480 pCi/gram (EPA83b).

The Uravan operation uses several other ponds in its water management system. Six solvent extraction (SX) raffinate evaporation/seepage ponds receive barren solution from the vanadium SX section. Residue in these ponds will be placed in the tailings ponds at closure. The SX ponds cover 15 ha (36 acres) (NRC84).

The general area is sparsely populated. A recent survey indicates 349 people living from 2 to 5 km (1.2 to 3.0 mi) away from the main tailings impoundments. The survey showed nobody living within 0.5 km (0.3 mi) of these impoundments, but 147 people lived 0.5 to 1.0 km (0.3 to 0.6 mi) distant (PNL84).

The climate at Uravan is semiarid, with only about 25 cm (10 inches) of precipitation a year. Evaporation is about 142 cm (56 inches) per year (EPA83b).

4.2.2 New Mexico

The five licensed mills located in New Mexico are operated by Sohio/Kennecott Minerals, United Nuclear Corporation, Anaconda (Atlantic Richfield), Kerr-McGee Corp. (Quivira Mining), and Homestake Mining Co. (see Figure 4-3). Two additional mills, Bokum Resources Corporation and Gulf Minerals, were licensed but have never operated.

L-Bar Mill

The Sohio/Kennecott L-Bar Uranium Mill is located near Seboyeta in Cibola County, in an area of hilly terrain about 71 km (44 mi) west of Albuquerque and 16 km (10 mi) north of Laguna, New Mexico. Ore is obtained from an underground mine in the Jackpile sandstone formation. The acid-leach mill began operations in 1976, but has been on standby status since May 1981 (NRC84). The ore processing capacity of the mill is 1650 tons per day. Ore reserves are adequate to provide for 10 to 15 years of operation. The ore grade varies from 0.05 to 0.30 percent U_3O_8 and averages 0.225 percent (NRC84). Size reduction is accomplished by semiautogenous grinding.

Mill tailings are contained in a single tailings impoundment. The L-Bar tailings dam was one of the last dams permitted in the industry in which the upstream construction method was used (Jo80). The tailings impoundment is built above grade with an earthen starter dam to the west that keys into natural topography on the north and south. A smaller saddle dam is constructed to the east. Tailings have been discharged to the impoundment from a single pipe that was moved along the dam. Coarse sands settled near the dike, whereas slimes deposited in the interior area. Water was decanted and pumped back to the mill. During operations, the edge of the tailings solution was maintained about 60 m (200 ft) from the dam crest. A light-track pressure dozer was used to construct raises with the sand tailings. The total impoundment area covers 72 ha (180 acres), about 51.2 ha (128 acres) of which are covered with tailings (NRC84). Approximately 11.2 ha (28 acres) of the tailings are covered with tailings solution (EPA85). The impoundment consists of about 1.6×10^6 tons of tailings. The maximum height of the dam is 15 m (50 ft) (NRC80). The facility was designed to provide an ultimate storage capacity of 7.5×10^6 tons of tailings (Jo80). The tailings are reported to contain 500 pCi/g of radium-226 (EPA83b).

During operations, ore is stockpiled at the mill on an ore pad and apron feeder. Since the plant went on standby status in 1981, no ore has been stored on these areas, but a short supply has been stored north of the tailings area (NM85).

The surrounding area is sparsely populated. A 1983 survey indicated no population residing within a 3-km (1.9-mi) radius of the tailings impoundment (PNL84). Reportedly 42 people live between 3 and 4 km (1.8 and 2.5 mi) away and 129 live between 4 and 5 km (2.5 and 3.1 mi) (PNL84).

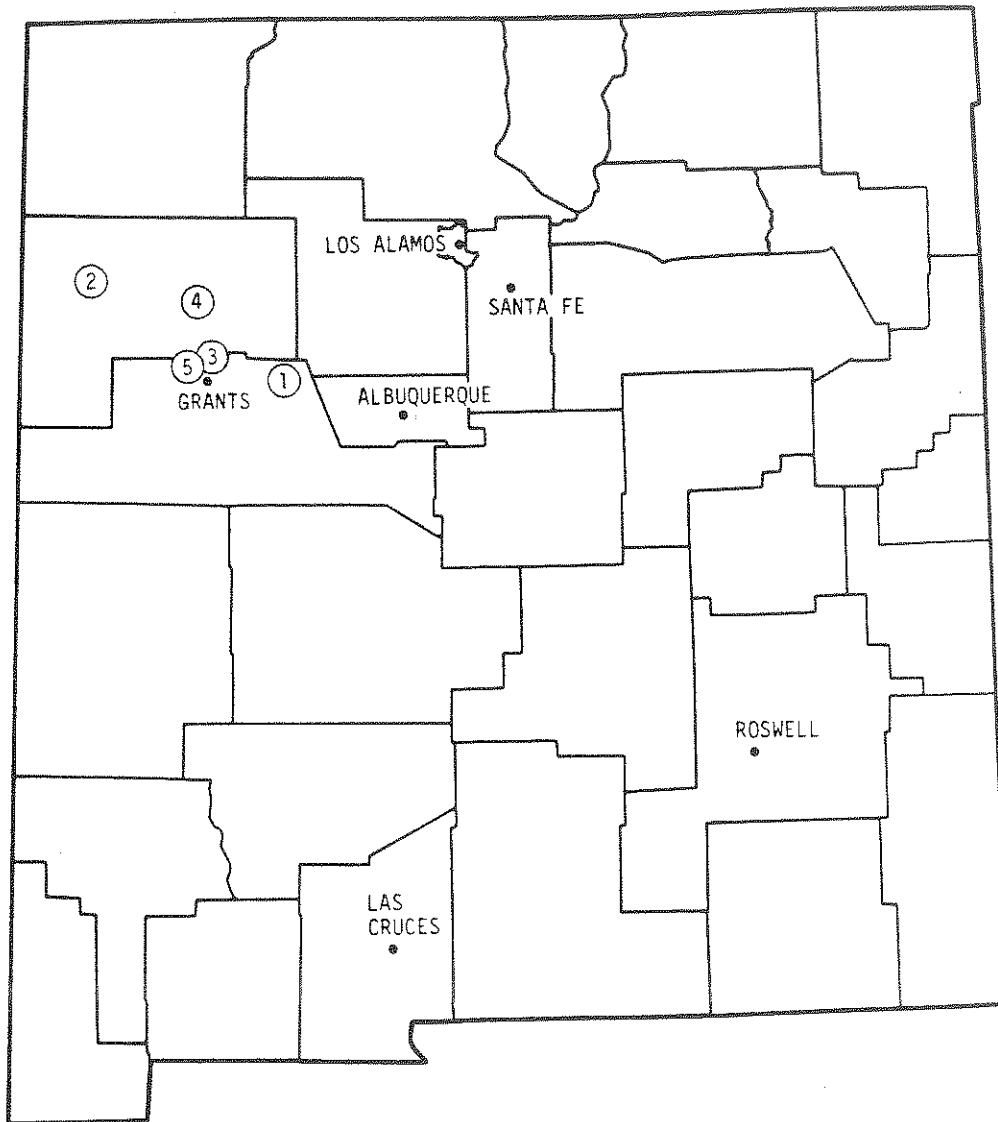

① Sohio
L-Bar Mill

② United Nuclear Corp.
Churchrock Mill

③ Anaconda Minerals Co.
Bluewater Mill

④ Kerr-McGee Nuclear Corp.
Quivara Mill

⑤ Homestake Mining Co.
Homestake Mill

Figure 4-3. Location of mills in New Mexico.

Churchrock Mill

United Nuclear Corporation's Churchrock Mill is located 32 km (20 mi) northeast of Gallup, New Mexico, on an alluvial plain situated near an arroyo. The mill, which opened in 1977, is designed to use acid-leach extraction to process about 4000 tons of ore per day from the company-owned underground mines. The ore contains 0.035 to 0.381 percent U_3O_8 (average is 0.12 percent) in a sandstone matrix. Fresh water for mill operations is obtained from underground mines. The mill has been on standby status since 1982.

The tailings impoundment is formed by a dam built from native clays and compacted coarse tailings. It has three compartments separated by earthen embankments. The total surface area of tailings is 59 ha (148 acres) (EPA85). The surface area of liquid on the tailings impoundment is 3 ha (7 acres). The maximum depth of tailings is about 15 m (50 ft). The storage capacity of the pond is about 10×10^6 m³ (365×10^6 ft³) (NRC84). The tailings are reported to contain 290 pCi/g of radium-226 (EPA83b).

The area around the mill is sparsely populated. The 1983 population survey indicated 25 people residing within 2 km (1.25 mi) and 77 living within 3 km (1.9 mi) (PNL84). The survey also indicated a total of 213 people living within 5 km (3.1 mi) of the mill, but none within 1 km (0.6 mi) (PNL84).

In July 1979, a break in the tailings dam caused about 350×10^6 liters (93×10^6 gal) of effluent and 1100 tons of tailings to spill on or into nearby soil and streams (NRC84). This spill resulted in the release of almost all of the impounded liquid, but less than 1 percent of the solids. The streams carried the spilled tailings into the Rio Puerco River, which flows through Navajo grazing lands, and finally into Arizona. The mill was closed from July 1979 until the fall of 1979 while measures were taken to clean up the streams contaminated by the spill. The cleanup of the streams has been completed. The mill has been inactive since 1982, and corrective action to clean up the contaminated groundwater is continuing (NRC84).

Bluewater Mill

Anaconda's Bluewater Uranium Mill is located in the Grants Mineral Belt about 16 km (10 mi) northwest of Grants, New Mexico. The site is in a small valley characterized by an undulating, relatively level surface with gentle swales and small rounded hills (DOE82). The mill was originally constructed in 1953 and operated until 1982, when it went to standby status. Since 1953, the milling operations have gone through several major modifications. Capacity has been expanded to 6000 tons of ore (0.2 percent U_3O_8) (NRC84). Production has been under both AEC (1956 to 1970) and commercial contracts. Through 1981, the Bluewater mill had processed more than 23.5×10^6 tons of ore ranging from 0.06 to 0.60 percent U_3O_8 (DOE82). Some decommissioning activities have been initiated at this mill.

The mill site has three tailings impoundments. Carbonate tailings from early operations were deposited in an area immediately northwest of the mill in a flat-lying impoundment (No. 2) covering about 19 ha (47 acres) (DOE82). This inactive impoundment has been covered with native soil to an average depth of 0.8 m (2.5 ft) (DOE82). Other tailings from the early carbonate processing were emplaced in what is now the main tailings impoundment for acid tailings (No. 1). A third tailings impoundment, the north area acid pile, is situated immediately northwest of the main pond. It covers 10 ha (24 acres), and in 1977 was covered with about 0.8 m (2.5 ft) of native soil (DOE82).

The main impoundment (No. 1), which was put in operation in 1956, covers 96 ha (239 acres) (EPA85). It is currently dry. The dam surrounding the pond is constructed of compacted natural soils and alluvium and is about 18 m (60 ft) high at the south end and 6 m (20 ft) high at the north end (DOE82). Tailings are discharged along the southern part of the dam. This impoundment contains 25×10^6 tons of tailings (NRC84).

There are also 162 acres of evaporation ponds in the mill water management circuit. Currently, 97 acres are covered with solution, 17 acres are exposed and wet, and 48 acres are exposed and dry (EPA85). Some tailings solids are carried with the water to these evaporation ponds where they remain after the solution evaporates.

The specific activity of radium-226 in the old tailings has been reported to be 520 pCi/gram and 280 pCi/gram in the tailings in the main pond (NM85); however, it has also been estimated to average 620 pCi/g (EPA83a).

The area around the Bluewater Mill is sparsely populated. A 1983 survey indicated 907 people living within 5 km (3.1 mi) of the mill (PNL84). Of this total, 142 lived within 3 km (1.9 mi.). No one lives within 2 km (1.2 mi.) of the mill (PNL84).

Annual precipitation averages 22 cm (8.8 inches)--most as rain, but some as snow. Wind is channeled through the valley in a westerly direction. The site is in the "southwest mountains" climatological subdivision of New Mexico.

Quivira Mill

Kerr McGee's Quivira mill has been on standby status since February 1985. The largest acid leach mill in the United States, its current capacity is 6350 t (7000 tons) of ore per day (NCR84). The Quivira mill is in a flat area of the Grants Mineral Belt about 40 km (25 mi) north of Grants, New Mexico. The mill began operation in 1958 with a capacity of 3270 t of (3600 tons) sandstone ore per day.

All of the tailings from the mill are contained in two main impoundments, (Tailings impoundments Nos. 1 and 2a) and two ancillary impoundments (2b and 2c). Impoundment No. 1 was the most recently active area for tailings deposition. It extends southeasterly from the mill for about 1370 m (4500 ft); its greatest width is about 820 m (2700 ft), and the outside berm ranges from 8 to 27 m (25 to 90 ft) above ground level (DOE82). An earthen starter dike was used along with the upstream method of tailings disposal. Tailings were discharged to the pond from multiple spigots located along the crest at 9-m (30-ft) intervals. The bulk of the sands is deposited on a beach inside the berm, and the slimes and liquid flow into the central depression to form a lake (DOE82). The operator maintains a 150-m (500-ft) wide beach and a 1.5 m (5 ft) freeboard during operation. Impoundment No. 1 covers 108 ha (269 acres) and contains a liquid covered area of about 6 ha (14 acres) (EPA85). Approximately 76 ha (191 acres) are dry and the remaining 26 ha (64 acres) remain saturated (EPA85).

Tailings Impoundment No. 2a covers about 42 ha (105 acres) and is west of and contiguous with Pond No. 1 (EPA85). Impoundments Nos. 1 and 2a have been in use since 1958. These two impoundments contain approximately 26×10^6 tons of tailings. Some tailings are used as backfill in a nearby underground mine. Tailings set aside for use as backfill

are contained in Impoundment No. 2b. Heap leached tailings are contained in Impoundment No. 2c. Impoundments 2b and 2c cover 11 and 12 ha (28 and 30 acres), respectively. Although no water is currently ponded in either of these impoundments, 1 to 1.5 ha (3 or 4 acres) of each are saturated (EPA85). The tailings are reported to contain 620 pCi/g of radium-226 (EPA83b).

The Quivira mill uses 15 evaporation ponds in its water management system. These ponds currently cover a total of 149 ha (372 acres) (EPA85). Of this total surface area, 107 ha (268 acres) are covered with solution, 4 ha (10 acres) are wet, and 38 ha (95 acres) are dry (EPA85). Some tailings solids are carried with the liquid solution and are deposited in these evaporation ponds.

The area surrounding the mill is sparsely populated. The 1983 population survey indicated only one person living within 5 km (3.1 mi) of the mill (PNL84), and that person lived between 2 and 3 km (1.2 and 1.9 mi.) from the impoundment (PNL84).

Precipitation averages 22 cm (8.8 in.) per year (DOE82). Local winds are channeled by the valley, and gusts can exceed 80 km (50 mi) per hour.

Homestake Mill

Homestake Mining Company's mill is 16 km (10 mi) northwest of Grants, New Mexico. The mill began production in 1958. Since its beginning, its capacity has been increased from 675 t (742 tons) to its present 3200 t (3400 tons) of ore per day (DOE82). The Homestake Mill uses the alkaline leach process. The mill has been on standby status since mid-1985. The ore grade milled at Homestake has ranged from 0.05 to 0.30 percent U_3O_8 (NRC84).

The mill site is relatively flat and covers about 600 ha (1500 acres). Two tailings impoundments, one on standby and the other inactive, are located on site. The inactive impoundment contains tailings generated between 1958 and 1962 under AEC contracts. The 1.1×10^6 t (1.2×10^6 tons) of AEC tailings cover about 18 ha (44 acres) and are contained within an 8-m (25-ft) high earthen embankment (DOE82). There currently is 1.6 ha (4 acres) of ponded water on the impoundment (EPA85). Approximately 20 percent, 3.2 ha (8 acres), of this tailings impoundment has been covered with a meter of contaminated soil excavated from an area affected by a past spill from the active impoundment (DOE82). Efforts have been made to revegetate the impoundment to reduce dusting.

The active impoundment contains about 20×10^6 tons of commingled tailings (DOE82). The impoundment is shaped like a large rectangular-base prism that rises above the flat ground surface (DOE82). It has a surface area of 82 ha (205 acres) (including the sides) and is about 26 m (85 ft) high. The slopes of the four sides are about 2:1 (h:v). The top of the impoundment is divided into two cells which are used alternately for tailings discharge. Most of the interior of both cells is covered with tailings solution. The total surface area of the ponded fluid in these two cells is about 25 ha (63 acres) (EPA85). Homestake maintains a 15-m (50-ft) beach and 1.5-m (5-ft) freeboard. The embankments are constructed of coarse tailings (sands) built up by the centerline method of construction. A mobile cyclone is used to separate the sands and slimes. Decanted pond liquid is recycled back to the mill. Surface water sprays and chemical treatments are applied to the embankment faces to inhibit dusting. The tailings are reported to contain 385 pCi/g of radium-226 (EPA83b).

Residential areas are located within 1.6 km (1 mi) of the mill. Homestake's 1982 license renewal application and the 1983 survey both indicated no population within 1 km (0.6 mi). The 1983 survey indicated that 190 people live between 1 and 2 km (0.6 to 1.2 mi.) from the impoundment (PNL84). The survey counted a population of 396 people within 5 km (3.1 mi.) of the mill (PNL84). Homestake has purchased additional land adjacent to the mill site to provide a 0.8-km (0.5-mi.) buffer zone (DOE82).

The site's climate is characterized by low precipitation [22 cm (8.8 in.)/y average], sunny days (75 to 80 percent), low humidity, wind gusts to 80 kilometers per hour (50 mph), and moderate temperatures with large diurnal and annual fluctuations (DOE82).

4.2.3 Texas

The three licensed mills in Texas are owned by Chevron Resources, Conoco-Pioneer, and Exxon Minerals. Their locations are indicated in Figure 4-4. One additional mill, Anaconda Minerals Rhode Branch Mill, was licensed in 1982, but was never constructed. Only the Panna Maria Mill is described herein, as the others are being decommissioned.

Panna Maria Mill

The Panna Maria Uranium Project of Chevron Resources Company is located in South Texas about 160 km (100 mi) northwest of Corpus Christi and 10 km (6 mi) north of Karnes City. The mill processes about 2600 tons per day of a mixture of sandy clay ore

averaging 0.05 percent U_3O_8 (Ma85). This facility, which uses semi-autogeneous grinding followed by acid leaching, began operation in January 1979 and has been on standby status since June 1985 (Ma85).

Tailings are contained in a single above-ground impoundment contained by earthen dikes. Material for the dikes was excavated from the area beneath the impoundment. The tailings area covers 50 ha (124 acres); 14 ha (36 acres) consist of dry, exposed beach, and about 27 ha (68 acres) are covered with tailings solution (EPA85). The impoundment contains approximately 3.3×10^6 tons of tailings (NRC84). It was designed to contain all the tailings projected to be generated over the life of the mill. The maximum height of the earthen dam surrounding the pile is 19 m (62 ft), the crest width is 6 m (20 ft), and the downstream slope is 3:1 (h:v) (Ki80). Designed maximum storage of tailings in this impoundment is 10×10^6 tons (Ki80). The average density of the tailings is 1.2 t/m^3 (0.04 ton/ft^3), and the specific gravity is 2.55 (Ki80).

During operations, the tailings discharge to the impoundment is periodically moved around the perimeter of the impoundment. An exposed beach of coarse tailings forms along the dike and the tailings solution gathers in the center portion of the pond. The depth of the solution varies from an average of 1.5 m (5 ft) on the east side to 5 to 6 m (15 to 20 ft) on the west (Ma85).

The radon-222 flux from the tailings has not been measured. The radium-226 content of the tailings is estimated to be 196 pCi/g.

The ore pad at this facility covers approximately 12 ha (30 acres). During normal operations, a 1-month supply of ore [69,000 t (76,000 tons) at capacity] is stockpiled on the pad.

A 1983 survey of population in the area indicated 453 people living within 5 km (3.1 mi) of the tailings impoundment, 12 people within 1 km (0.6 mi), 42 people within 1 and 2 km (0.6 and 1.25 mi), and 33 people within 2 and 3 km (1.25 and 1.9 mi) (PNL84).

The average annual rainfall at the location of the impoundment is 76 cm (30 in.), and the net annual evaporation is 89 cm (35 in.).



① Conoco/Pioneer Nuclear
Conquista Project

② Chevron Resources Co.
Panna Maria Mill

③ Exxon Minerals
Ray Point

Figure 4-4. Location of mills in Texas.

4.2.4 Utah

The four licensed mills located in Utah (see Figure 4-5) are owned by Atlas Minerals, Plateau Resources, Ltd., Umetco Minerals, and Rio Algom Corporation.

Umetco White Mesa Mill

The Umetco Minerals White Mesa mill, which is about 8 km (5 mi.) south of Blanding, Utah, began operating in July 1980. This mill is currently active. Semi-autogenous grinding, acid-leaching, and solvent-extraction are used to process ores containing about 0.13 percent U_3O_8 (NRC84). The capacity of the mill is 1800 t (2000 tons) of ore per day (NRC84).

Approximately 500,000 t (550,000 tons) of tailings are contained in three cells of a proposed six-cell disposal system. The cells contain 19, 24, and 21 ha (48, 61, and 53 acres) of tailings for a total of 64 ha (162 acres) (EPA85). A total of 22 ha (56 acres) is covered by solution, 5 ha (13 acres) are saturated, and 42 ha (106 acres) are dry (EPA85). The proposed system was planned to feature simultaneous construction, operation, closure, and reclamation. The tailings impoundments are lined with synthetic liners. The tailings are reported to contain 350 pCi/g of radium-226 (EPA83b).

A 1983 population survey indicated no people living within a 4-km (25-mi) radius of the tailings impoundment (PNL84). The same survey indicated eight people living between 4 and 5 km (2.5 and 3.1 mi) of the tailings disposal area (PNL84).

Rio Algom Mill

The Rio Algom Mill is near La Sal, Utah, about 48 km (30 mi) southeast of Moab. This mill is currently active and has been in operation since 1971. Ore obtained from adjacent underground mining operations is processed by alkaline leaching and ion exchange. The mill's designed throughput is 700 t (750 tons) of ore per day.

Over 1.6×10^6 t (1.8×10^6 tons) of tailings have been generated at this mill (NRC84). The tailings are contained in two unlined tailings impoundments retained by natural soil embankments placed across a drainage course, one immediately upstream of the other (NRC84). The lower impoundment has been in use since 1972, the upper since 1976. The total area of tailings is 30 ha (75 acres) (EPA85). Approximately 6 ha (16 acres) are covered with solution, 3 ha (7 acres) are saturated, and 21 ha (53 acres) are dry (EPA85). The tailings are reported to contain 560 pCi/g of radium-226 (EPA83b).

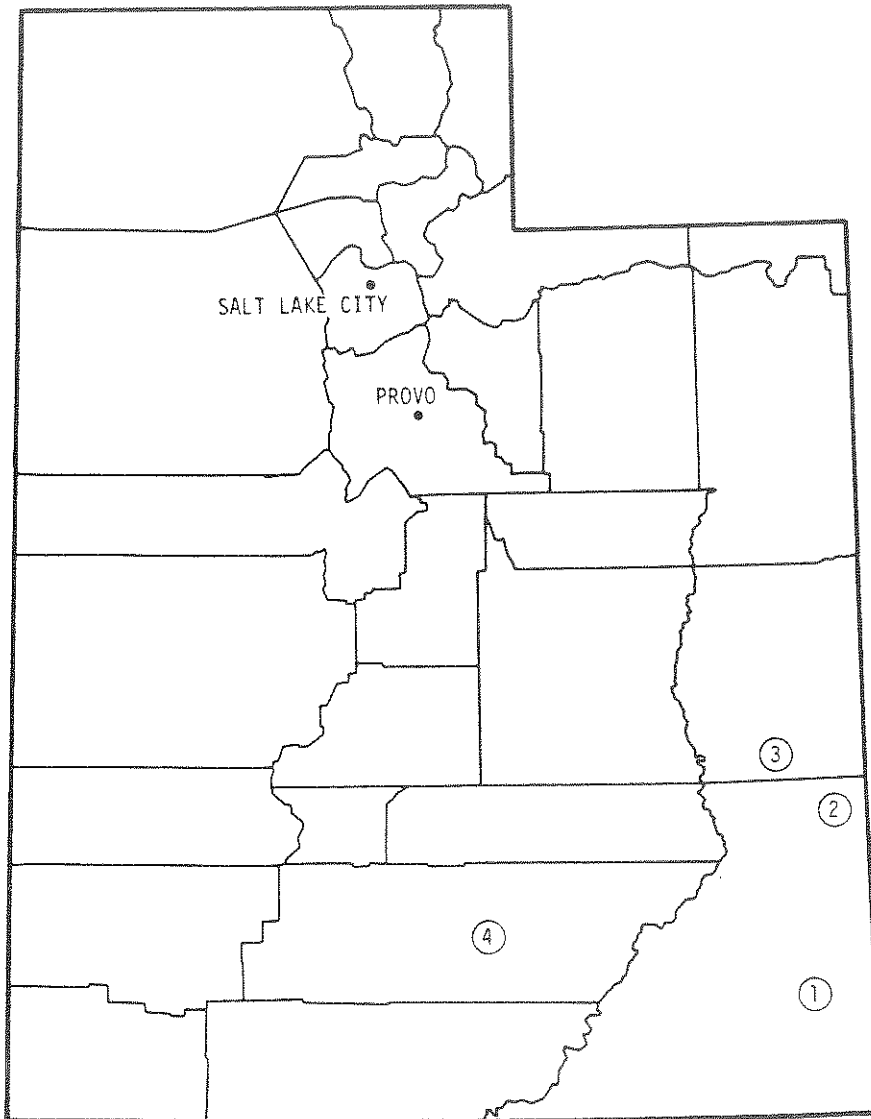

- | | |
|--------------------------------------|---|
| ① Umetco Minerals
White Mesa Mill | ③ Atlas Minerals
Moab Mill |
| ② Rio Algom Corp.
La Sal Mill | ④ Plateau Resources, Ltd.
Shootaring Canyon Mill |

Figure 4-5. Location of mills in Utah.

A 1983 survey of the population in the area indicated no inhabitants living within 0.5 km (0.3 mi.) of the tailings impoundment (PNL84). Eight inhabitants were reported to live between 0.5 and 1.0 km (0.3 and 0.6 mi) from the impoundment, and 105 people between 1 and 2 km (0.6 and 1.2 mi) from the impoundment (PNL84).

Moab Mill

The Atlas Corporation Mill is located on the Colorado River in a long, narrow valley of a mountainous area about 5 km (3 mi.) northwest of Moab, Utah. The mill, which began operations in October 1956, is on standby status. This mill has combined acid and alkaline circuits, which give it greater flexibility in handling a variety of ores (DOE82). Uranium has been produced for sale to both government and commercial buyers. Capacity of the mill is 1980 tons of ore per day (NRC84).

Prior to 1977, mill tailings were discharged to the Colorado River (NRC84). Since that time, all tailings have been placed in a single tailings impoundment. The dam has been constructed mainly of coarse tailings. Tailings are discharged from multiple spigots around the perimeter of the dam. The coarse sand is deposited on and near the dam, whereas the fines are carried to the interior of the impoundment with the tailings solution. The impoundment's total surface area is 60 ha (147 acres (EPA85)). Of the total area, 22 ha (54 acres) are covered by ponded solution, 2 ha (4 acres) are saturated, and 36 ha (90 acres) are exposed dry tailings (including the dams) (EPA85). Because the impoundment is on a sloping surface, its height varies from 6 to about 36 m (20 to about 120 ft) above ground (DOE82). Between 7 and 9 x 10⁶ t (8 and 10 x 10⁶ tons) of tailings are contained in this impoundment (DOE82, NRC84).

The radium-226 content of the tailings has been reported to be 540 pCi/gram (EPA83). Ore grade ranges from 0.20 to 0.25 percent U O₈ (NRC84).

Moab is the only nearby incorporated community. A 1983 survey indicated a total population of 2361 within a 5-km (3.1-mi) radius of the tailings pile (PNL84). The same survey indicated no people living within 1.0 km (0.6 mi) and 9 people within 1 and 2 km (0.6 and 1.2 mi) from the impoundment. The survey also indicated that 2319 people were living between 3 and 5 km (1.8 and 3.1 mi) of the mill (PNL84).

The climate at the site is semiarid. Annual precipitation is 20 cm (8 inches), and the annual evaporation rate is 163 cm (64 inches) (EPA83). As a means of minimizing dusting, the dried tailings are sometimes wetted with sprinklers and/or a chemical dust suppressant, such as Coherex (DOE82). Windspeeds usually are quite low (DOE82).

Plateau Resources Mill

The Plateau Resources Shootaring Canyon Mill is located near Hanksville, Utah. This mill was operational only from April to October 1982 and is currently on standby status. The capacity of the mill is 725 t (800 tons) per day (NRC84). The average ore grade is 0.15 percent U_3O_8 , ranging from 0.07 to 0.24 percent (NRC84). An average of approximately 97,000 tons of surface mined ore is stockpiled on site when the mill is running at capacity (Ge85). The primary mill circuit involves semi-autogenous grinding of the sandstone ores, followed by a sulfuric acid leach. Tailings are disposed of in a planned, phased disposal system. An earthen dam has been constructed across the valley. Behind the earthen dam, berms have been constructed to form six cells for tailings disposal. Because of the short period of operation, only one cell contains a significant quantity of tailings. Two other cells contain only minor quantities, and the other three cells contain none. The area of the tailings is only 3 ha (7 acres), and about 0.8 ha (2 acres) of these are covered with water (EPA85). Plateau Resources has taken steps to stabilize this impoundment temporarily by inducing water evaporation and placing a 0.3-m (1-ft) cover of local soil over 1.2 ha (3 acres) of the tailings to limit windblown dust. This interim stabilization process will be completed in approximately 3 years. Radon-222 flux from the tailings has not been measured.

The area around the mill is sparsely populated; no inhabitants live within a 4-km (2.4-mi.) radius (PNL84). The 1983 survey indicated 171 people living within 4 and 5 km (2.4 and 3.1 mi) of the tailings impoundment (PNL84).

4.2.5 Washington

Washington has two licensed conventional mills, owned by Dawn Mining (Newmont Mining/Midnight Mines) and Western Nuclear, Inc. (Phelps Dodge) (see Figure 4-6). Another mill, owned by Joy Mining Company, was licensed, but was never fully operational. This latter mill is not typical as it processed a bog material on a leach pad. Only 820 t (900 tons) of tailings (heap leached bog material) was generated. It is reported that this residue has a low radium-226 content (WA86). The license for this mill was suspended in June 1985.

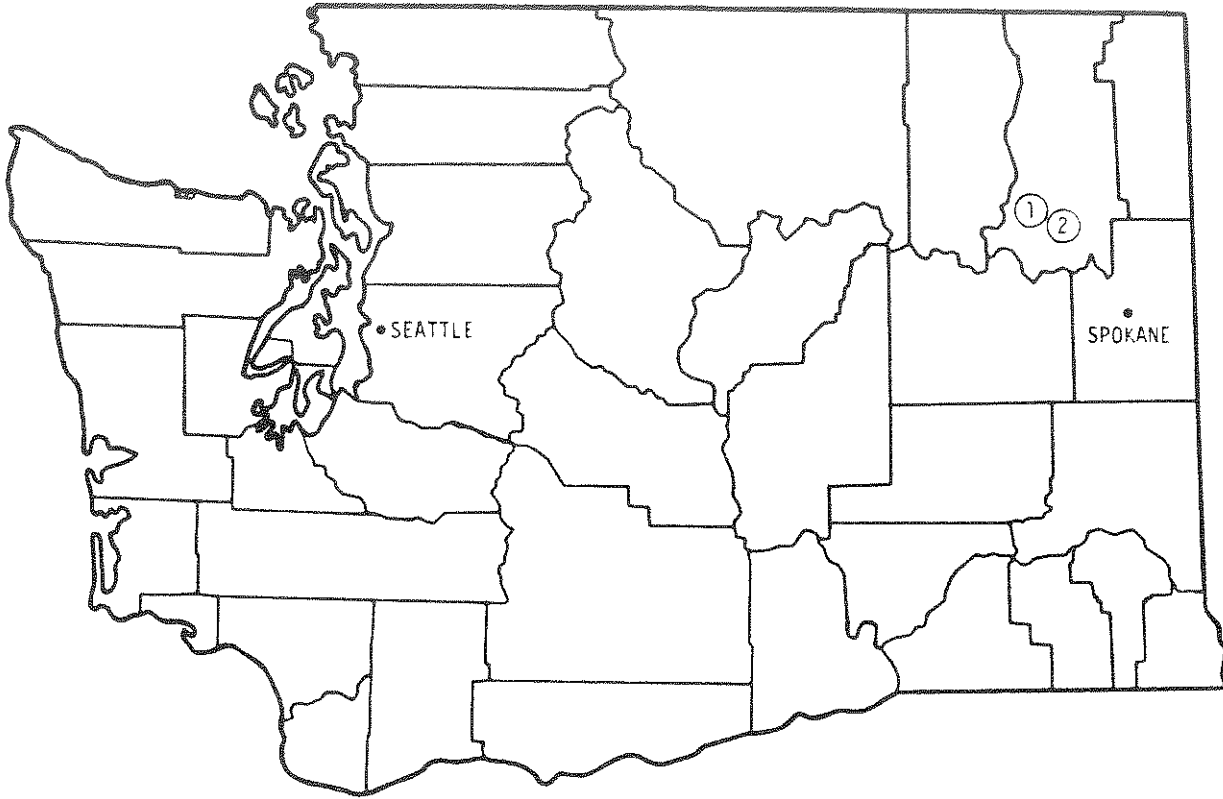

- ① Dawn Mining Co.
Ford Mill
- ② Western Nuclear, Inc.
Sherwood Mill

Figure 4-6. Location of mills in Washington.

Dawn Mining Mill

The Dawn Mining Mill, which is near Ford, Washington, about 72 km (45 mi) northwest of Spokane, is jointly owned by Newmont Mining Corporation and Midnight Mines, Inc. It began operations in 1957 and operated through 1964 under the AEC concentrate purchase program. The mill was shut down and rehabilitated between 1965 and 1969. It operated between 1969 and 1982, but has been inactive and on standby status since 1982.

The production capacity of the mill is 550 t (600 tons) of ore per day. The mill circuit incorporates a two-stage agitation acid leach process followed by ion exchange and precipitation of uranium with ammonia. The Midnight mining open-pit mine produces ore between 0.10 and 0.25 percent U_3O_8 (NRC84). During operations, a 1-year supply of ore [193,000 t (212,300 tons)] was maintained on a 6-ha (14-acre) stockpile at the mill site (DOE82).

The tailings generated by the Dawn Mill are contained in four separate impoundments, three of which are above grade, unlined, and constructed behind earthen dams. These three impoundments have been filled to capacity and are inactive. Impoundment Nos. 1 and 2 contain an estimated 1.2×10^6 tons of tailings from government contract production. They have been covered with about 0.61 m (2 ft) of sandy soil and wood chips for dust control and interim stabilization (DOE82, Ap84). Impoundment No. 3, which contains about 1.6×10^6 tons of tailings, has also been covered with sandy soil and wood chips. These three impoundments have a surface area of 38 ha (95 acres), all of which is dry (EPA85). Impoundment No. 4 is an excavated, below-grade, lined (Hypalon) pond covering 11 ha (28 acres). Seven hectares (17 acres) are covered by solution and 4 ha (11 acres) are dry (EPA85). The tailings are covered with water to a depth of 1.2 to 1.5 m (4 to 5 ft). The radium-226 content of the Dawn Mill tailings is reported to be 240 pCi/g (EPA86).

The community of Ford is located within 3.2 km (2 mi) of the tailings impoundments. In 1983 approximately 411 people were living within 5 km (3.1 mi.) of the tailings impoundments (PNL84). No one lived within 0.5 km (0.3 mi) and 3 people lived within 0.5 and 1.0 km (0.3 and 0.6 mi). Ninety-three people lived within 1 and 2 km (0.6 and 1.2 mi) and 157 lived within 2 and 3 km (1.2 and 1.9 mi) of the impoundments (PNL84).

The area's topography is characterized by rolling hills. The average annual precipitation is 30 to 46 cm (12 to 18 in); annual evaporation is about 127 cm (50 in) (EPA83b).

Western Nuclear Sherwood Mill

Western Nuclear's Sherwood uranium mill is located in eastern Washington about 64 km (40 mi) northwest of Spokane. Ore taken from a nearby surface mine has averaged 0.05 to 0.09 percent U_3O_8 (EPA83). This mining and milling operation, which began in 1978, has been inactive and on standby status since July 1984.

The tailings generated by acid leaching at the Western Nuclear Mill have been placed in a single above-grade impoundment behind an earthen dam. The area covered by tailings is 38 ha (94 acres) (EPA85). Of this total, 7 ha (18 acres) are covered with tailings solution, 28 ha (70 acres) are dry, and the remainder is saturated (EPA85). Tailings slurry from the mill was neutralized with lime before being pumped to the Hypalon-lined impoundment. Tailings solution decanted from the impoundment was pumped to a 16-acre evaporation pond situated immediately upstream of the tailings impoundment. The current amount of tailings under management is estimated to be (1.6 x 10⁶ tons) (NRC84). The tailings are reported to contain 200 pCi/g of radium-226 (EPA83).

The area is sparsely populated. A 1983 survey indicated 49 people living between 3 and 5 km (1.9 and 3.1 mi) away from the tailings impoundment (PNL84). This survey also indicated that no one was living within 3 km (1.9 mi) of the impoundment. Annual precipitation is 25 to 38 cm (10 to 15 in.), and annual evaporation is about 127 cm (50 in.) (EPA83b).

4.2.6 Wyoming

As shown in Figure 4-7, nine mills are located in Wyoming. Three of these have been decommissioned, two are active, and four are on standby status. Descriptions of the active and standby mills are presented in the following subsections.

Pathfinder Gas Hills Mill

The Pathfinder Mines Corp. (formerly Lucky Mc Corp.) Gas Hills Mill is located in the Gas Hills region of Fremont County, Wyoming, about 40 km (25 mi.) northeast of Jeffrey City.

This mill first began producing yellowcake in 1958 with a nominal ore-processing capacity of 850 t (935 tons) per day. Since then, the capacity has been expanded to about 2273 t (2500 tons) of ore per day. The mill uses an acid-leach process and was the first in the United States to incorporate the moving-bed, ion-exchange technique originally developed in South Africa. It is also the only domestic uranium mill that uses anion exchange for concentration of uranium from the feed solution.

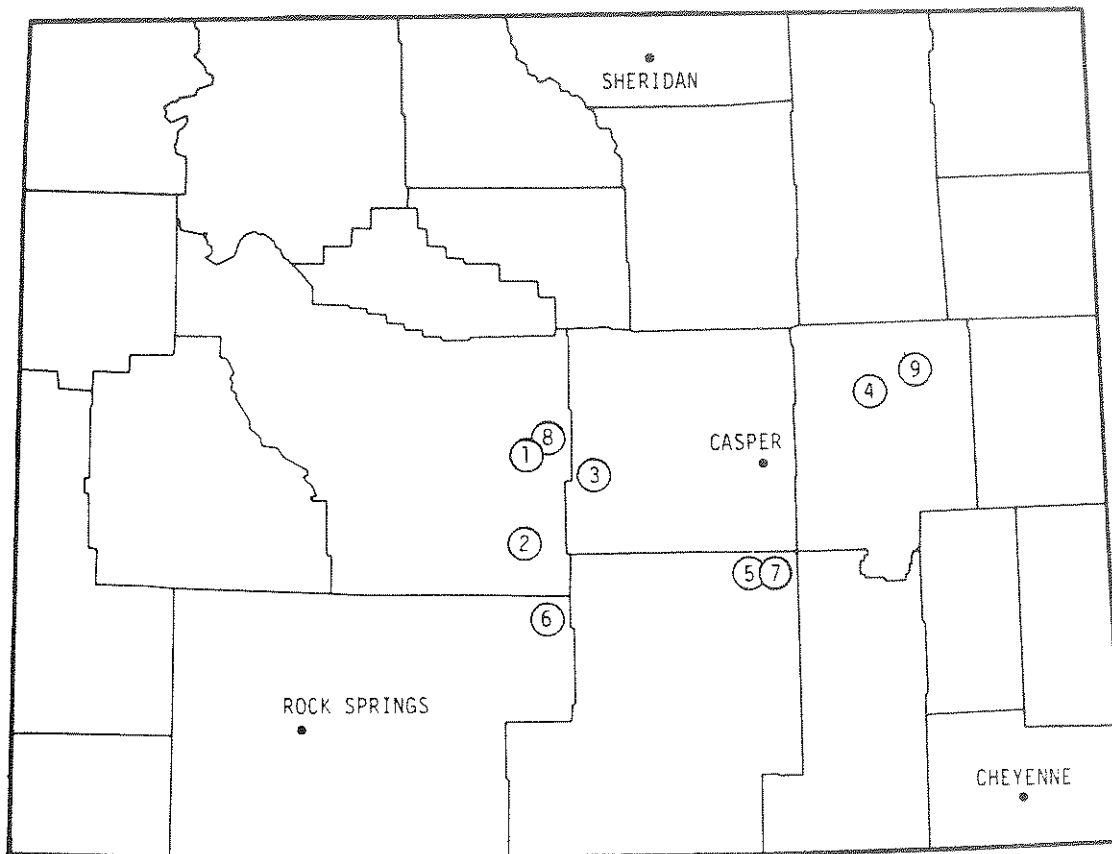

- | | | | |
|---|--|---|---|
| ① | Pathfinder Mines Corp.
Gas Hills Mill | ⑥ | Minerals Exploration Co.
Sweetwater Mill |
| ② | Western Nuclear, Inc.
Split Rock Mill | ⑦ | Petrotomics
Shirley Basin Mill |
| ③ | Umetco
Gas Hills Mill | ⑧ | American Nuclear Corp.
Gas Hills Mill |
| ④ | Rocky Mountain Energy
Bear Creek Mill | ⑨ | Exxon Corp.
Highland Mill |
| ⑤ | Pathfinder Mines Corp.
Shirley Basin Mill | | |

Figure 4-7. Location of mills in Wyoming.

Company-owned open-pit mining operations, located 1.5 to 3 km (1 to 2 mi) from the mill, supply 90 percent of the ore; the remaining 10 percent is produced at Pathfinder's Big Eagle Mine near Jeffrey City. The ore grade has averaged 0.21 percent U_3O_8 in past operations and is expected to average 0.11 percent in the future (Ha85). Although mines adjacent to the mill also could provide fresh water for ore processing, the availability of hot [57°C (135°F)] well water at the site makes it advantageous, from a process standpoint, to use well water in the mill and to treat mine water for discharge.

The tailings retention system consists of four tailings impoundments having surface areas of 50, 22, 9, and 36 ha (124, 54, 22 and 89 acres) (EPA85). The impoundments are situated sequentially in the head of a draw north-northeast of the mill and are dug into an underlying shale formation. The clay core dams are keyed into the shale. The average tailings depth is now 12 m (40 ft) and is expected to increase to 18 m (60 ft) by the end of the projected milling operation in 1996 (Ha85). Water is sprayed over 8 ha (19 acres) of the dry tailings during warm weather to control dust (Ha85). Dry beaches account for 69 ha (172 acres) of the total, whereas 38 ha (96 acres) are covered with tailings solution. The remaining 8 ha (21 acres) of exposed tailings are saturated with solution (EPA85). The current amount of tailings under management is 11.5×10^6 tons) (Ha85).

The radium-226 activity for the solid tailings, combined sands, and slimes is about 160 pCi/g (Ha85). An earlier EPA report estimated the radium-226 content at 420 pCi/g (EPA83b). The radium-226 activity of the tailings liquid is approximately 200 pCi/liter (Ha85).

The Pathfinder Gas Hills Mill is in a remote location away from permanent habitation. The nearest residence is approximately 19 km (12 mi) away (Ha85). A 1983 survey also indicates no population within a 5-km (3-mi) radius of the tailings piles (PNL84).

In 1963 a flood at the mill site resulted in the release of 8.7×10^7 liters (2.3×10^7 gal) of impounded tailings solution to the environment. As a result of this incident, the tailings impoundment was enlarged to its current capacity. The existing system, with a minimum of 1 m (3 ft) of freeboard, is estimated to provide 12.6×10^8 liters (3.3×10^8 gal) of emergency storage.

Western Nuclear Split Rock Mill

Western Nuclear's Split Rock Mill is located 3.2 km (2 miles) north of Jeffrey City, Wyoming. This mill began operation in 1957 and has been on standby status since June 1981. When running at capacity, the mill produced 935 tons of yellowcake per year (Bo85). Maximum throughput was about 1700 tons of ore per day (NRC84). The ore grade has ranged from 0.15 to 0.30 percent U_3O_8 in the past and is expected to range from 0.05 to 0.15 percent in the future (NRC84). Milling operations involve semi-autogenous grinding, an acid leach, and solvent extraction. The mill usually stockpiles 2000 to 5000 tons of ore when it is operating. Two 8-m (25-ft) diameter bins are used to store fine ore.

The tailings generated by the Split Rock Mill are contained in a single tailings impoundment that is enclosed by an earthen dam. The tailings impoundment has a surface area of 62 ha (156 acres), and the maximum depth is about 29 m (95 ft) (EPA85, Bo85). Currently, 38 ha (94 acres) of the impoundment are covered by tailings solution (EPA85). There are 17 ha (43 acres) of dry tailings in the impoundment (EPA85). Tailings are discharged from the crest of the dam; the point of discharge is periodically moved along with the crest. Western Nuclear uses a sprinkler system to control dusting from the pond during nonfreezing months. Wind fences, chemical sprays, and vegetation seeding are also used to control dusting. About 12×10^6 tons of commingled tailings are under management (NRC84).

The average radium-226 concentration of the tailings is approximately 100 pCi/g (99.5 ± 42 pCi/g) (Bo85). Radium-226 values in the sands and slimes were determined to be 63 pCi/g and 87 pCi/g, respectively (Bo85). Western Nuclear has used charcoal canisters to measure radon-222 flux from the tailings. The average flux measurements, made in 1977-1978, were 2 ± 1.1 pCi/m²s (Bo85). An earlier EPA report indicated that 430 pCi/g of radium-226 was present in the tailings (EPA83b).

A 1983 population survey indicated that three people lived between 0.5 and 1.0 km (0.3 and 0.6 mi) from the tailings impoundment (PNL84). This survey further indicated that 30 people resided within 2 and 3 km (1.2 and 1.9 mi) of the tailings impoundment, 697 people within 3 and 4 km (1.9 and 2.5 mi), and 176 people within 4 and 5 km (2.5 and 3.1 mi) (PNL84).

Umetco Gas Hills Mill

The Umetco Minerals Gas Hills Mill is located in the southeastern portion of the Wind River Basin of Wyoming. The mill is about 95 km (60 mi) west of Casper in an area of rolling hills interspersed with relatively flat areas. The mill is currently on standby status.

An acid-leach system (RIP-Eluex system) is used to recover uranium. Recycled solution from the impoundment system is used to wash sands after sand-slime separation. Additional pond decant solution is used for tailings dilution. The mill began operation in early 1960 with a capacity of about 1100 tons per day; in January 1980, the capacity was increased to 1400 tons per day. In June 1983, milling of mined ore was temporarily curtailed, and only the heap leach facility was kept in operation. During milling operations, a 2-month stockpile of ore is maintained at the mill (Wo85). This amounts to 85,800 tons when the mill is operating at capacity.

During the anticipated total active life of the project (1960 to 1986), about 13×10^6 tons of mill tailings will have been produced. The retention capacity [7.6×10^6 t (8.4×10^6 tons)] of the mill's original above-grade tailings impoundment has been reached, and since January 1980, tailings have been discharged to a depleted open-pit mine (A-9 Pit), which has a capacity of 2.5×10^6 tons. This has an area of 10 ha (25 acres), is clay-lined on the bottom, and has an in-pit dewatering system. The A-9 Pit has an exposed dry tailings beach area of about 6 ha (14 acres) (EPA85). The maximum height of the embankment of the original above-grade tailings impoundment (and expansions) is about 14 m (45 ft). This impoundment has a surface area of 60 ha (151 acres), all of which is dry, and contains 5.8×10^6 t (6.4×10^6 tons) of commingled tailings (EPA85, Wo85). The inactive tailings area, which has not been used since January 1980, is currently in a preliminary phase of reclamation. The inactive impoundment has been covered with an average thickness of 1.2 m (4 feet) of overburden (Wo85). The tailings are reported to contain 310 pCi/g of radium-226 (EPA83b). The evaporation area consists of three ponds with a combined surface area of 8 ha (20 acres).

An EPA report estimates the radium-226 content of the tailings to be 310 pCi/g (EPA83b). No measurements of radon-222 flux from the tailings impoundment have been made at this site (Wo85).

The area is sparsely populated. A 1983 survey indicated no people living within a 5-km (3-mi) radius of the tailings impoundment (PNL84). Average annual precipitation is 25 cm (10 in.), and evaporation is 17 cm (42 inches) (EPA83b).

Under the current reclamation plan, Umetco is committed to provide a uniform cover of 0.3 m (1 ft) of clay and 2.6 m (8.5 ft) of overburden over the entire tailings area. This will require about 210,000 m³ (7.5 x 10⁶ ft³) of clay, at a cost of \$1,129,000, and 1.8 x 10⁶ m³ (65 x 10⁶ ft³) of overburden, at a cost of \$1,840,000 (NRC84). When the cost of revegetation is added, the basic materials needed for the reclamation program will cost about \$3,800,000.

Umetco also operates a heap leach facility in the mill area at its Gas Hill site. The water used in the process [1.7 liters/s (27 gal/min)] is taken from a nearby tailings area, and U₃O₈ is recovered from high-grade leach liquor by a solvent-extraction process. The organic phase is pumped to the mill circuit. Heap leach pads cover about 9 ha (22 acres) at this site (EPA85).

Rocky Mountain Energy Mill

Rocky Mountain Energy's Bear Creek Mill is part of a uranium project that includes open-pit mining operations in the Powder River area of Converse County, Wyoming, about 72 km (45 miles) northeast of Casper. The operation, which was dedicated in September 1977, has a capacity of 2000 tons of ore per day (NRC84). The U₃O₈ content of the ore ranges from less than 0.1 to 1.0 percent (NRC84). Ore is stockpiled at the mill on an 8-ha (20-acre) pad; approximately 66,000 tons are currently on hand (Me85). The mill is currently operating at about 20 percent of its capacity and is milling stockpiled ore. It is likely that the mill will go to standby status sometime during the second quarter of 1986.

Mill tailings are contained in a single tailings impoundment enclosed by an earthen dam. The surface area of tailings is 48 ha (121 acres), of which 18 ha (45 acres) are covered with tailings solution and 21 ha (53 acres) are dry tailings beaches (Me85). A portion, 13 ha (32 acres), of the pile has been covered with 30 cm (1 foot) of soil to control fugitive dust (Me85).

No measurements of radon-222 flux from tailings have been made at this site. The radium-226 content of the Bear Creek tailings is reported to be 420 pCi/g (EPA83b).

A 1983 survey indicated no one living within a 5-km (3.1-mi) radius of the tailings pile (PNL84). The annual precipitation in the area is about 30 cm (12 in.), and annual evaporation is 102 cm (40 in.) (EPA83).

Pathfinder Shirley Basin

The Pathfinder Mines Corporation Shirley Basin Uranium Mill is located in an area of plains and rolling hills about 72 km (45 mi) south of Casper, Wyoming. The mill, which began operation in 1971, uses semiautogenous grinding, leaching, and ion exchange. Current mill capacity is 1600 t (1800 tons) of ore per day (NRC84). The mill is currently active and has a throughput of 900 t (990 tons) per day (Si85). Operations are projected to continue through 1994.

Tailings are contained in a single onsite tailings impoundment that is contained above grade by a single-sided earthen retention dam 18 m (60 ft) high. The surface area of the tailings impoundment is 10 ha (261 acres), of which 72 ha (179 acres) are covered with ponded tailings solution (EPA85). Twenty-four hectares (60 acres) are dry beaches. The impoundment contains 5.8×10^6 t (6.4×10^6 tons) of tailings (NRC85). The tailings are reported to contain 540 pCi/g of radium-226 (EPA83b).

A 1983 survey of the population in the vicinity of the Pathfinder Shirley Basin Mill indicated no inhabitants living within 3 km (1.9 mi.) of the tailings impoundment (PNL84). Six people, who lived between 3 and 4 km (1.9 and 2.5 mi) from the impoundment, were the only inhabitants within 5 km (3.1 mi) (PNL84).

Minerals Exploration Mill

The Minerals Exploration Company's Sweetwater Mill is located within the Red Desert portion of Wyoming's Great Divide Basin, about 64 km (40 mi) northwest of Rawlins. The mill, which began operations in early 1981, has been inactive since November 1981 and is currently on standby status. The capacity of the mill is 2700 t (3000 tons) per day. The average ore grade processed to date has been 0.03 percent U_3O_8 (Hi85).

All tailings have been placed in a single tailings impoundment. It is a lined (synthetic) impoundment that is partially below grade and has earthen embankments. The total surface area of the tailings is 15 ha (37 acres) (EPA85). With the exception of a 3-ha (7-acre) delta at the tailings discharge point, the tailings are covered by tailings solution. Approximately 0.9×10^6 t (1×10^6 tons) of tailings have been generated and are contained in this impoundment. Plans call for a second cell to be constructed to the north of the existing cell if additional capacity is required. The Sweetwater tailings disposal system is a phased-disposal facility that has gone through several iterations during development. The impoundment was originally designed to be square, below-grade, and divided into four cells. The Minerals Exploration Company reports that measurements of radon-222 flux made on the tailings solids ranged from 90 to 100 pCi/m²s (Hi85).

A 1983 survey indicated no population living within 5 km (3.1 mi.) of the tailings impoundment (PNL84). The annual precipitation in the area is 15 to 20 cm (6 to 8 in.), and annual evaporation is 102 to 178 cm (40 to 70 in.) (EPA83).

4.3 Population Within 5 km (3.1 mi) of Existing Tailings Impoundments

A 1983 estimate indicated that 12,824 persons lived within 5 km (3.1 mi) from the centroid of the tailings impoundments at the active and standby sites (PNL84). No one lived within 0.5 km (0.3 mi), whereas 173 people lived between 0.5 and 1 km (0.6 and 1.2 mi). Nobody lived within 5 km (3.1 mi) of four of these mills, all of which were in Wyoming. A summary of this information by state and by mill is presented in Table 4-3. By comparison, a population survey conducted by EPA in 1985 showed that there were 11,483 people living within 5 km (3.1 mi) of these tailings impoundments. This more recent survey, which was based on interpretation of aerial photographs, indicated that no one lived within 5 km (3.1 mi) of six of these tailings impoundments. The results of this later survey are presented in Table 4-4.

Table 4-3. Estimate of the population living within 0 to 5 km from the centroid of tailings impoundments of active and standby mills in 1983^(a)

State/Owner	0.0-0.5	0.5-1.0	1.0-2.0	2.0-3.0	3.0-4.0	4.0-5.0	Total
Colorado							
Cotter	0	0	0	184	2767	2982	5933
Umetco	0	147	193	6	3	0	349
New Mexico							
Sohio	0	0	0	0	42	124	166
United Nuclear	0	0	25	52	85	150	312
Anaconda	0	0	6	136	666	99	907
Kerr-McGee	0	0	0	1	0	0	1
Homestake	0	0	190	104	45	57	396
Texas							
Chevron	0	12	42	33	81	285	453
Utah							
Umetco	0	0	0	0	0	8	8
Rio Algom	0	8	105	154	32	44	343
Atlas	0	0	9	33	1094	1225	2361
Plateau Resources	0	0	0	0	0	171	171
Washington							
Dawn	0	3	93	157	96	62	411
Western Nuclear	0	0	0	0	32	17	49
Wyoming							
Pathfinder (Gas Hills)	0	0	0	58	0	0	58
Western Nuclear	0	3	0	30	697	176	906
Umetco	0	0	0	0	0	0	0
Rocky Mt. Energy	0	0	0	0	0	0	0
Pathfinder (Shirley Basin)	0	0	0	0	0	0	0
Minerals Exp.	0	0	0	0	0	0	0
Total	0	173	663	948	5640	5400	12,824

(a) PNL84.

Table 4-4. Estimate of the population living within 0 to 5 km from the centroid of tailings impoundments of active and standby mills in 1985^(a)

State/Owner	0.0-0.5	0.5-1.0	1.0-2.0	2.0-3.0	3.0-4.0	4.0-5.0	Total
Colorado							
Cotter	0	0	0	90	1693	3029	4812
Umetco	0	0	14	0	0	0	14
New Mexico							
Sohio	0	0	0	10	60	161	231
United Nuclear	0	0	34	90	105	213	442
Anaconda	0	0	0	67	574	146	787
Kerr-McGee	0	0	0	0	0	0	0
Homestake	0	0	267	118	41	80	506
Texas							
Chevron	0	12	108	104	253	313	790
Utah							
Umetco	0	0	0	4	8	4	16
Rio Algom	0	0	12	16	186	88	302
Atlas	0	0	9	24	923	632	1588
Plateau Resources	0	0	0	9	115	100	224
Washington							
Dawn	0	0	119	253	75	71	518
Western Nuclear	0	0	0	0	56	48	104
Wyoming							
Pathfinder (Gas Hills)	0	0	0	0	0	0	0
Western Nuclear	0	0	6	48	737	358	1149
Umetco	0	0	0	0	0	0	0
Rocky Mt. Energy	0	0	0	0	0	0	0
Pathfinder (Shirley Basin)	0	0	0	0	0	0	0
Minerals Exp.	0	0	0	0	0	0	0
Total	0	12	569	833	4826	5243	11,483

(a) EPA85.

REFERENCES

- An84 Andrew R. E., "Uranium Mills Program, Department of Social and Health Services, State of Washington", Correspondence with PEI Associates, Inc., December 1984.
- Bo85 Bogden G., Western Nuclear, Inc., Correspondence with PEI Associates, Inc., January 1985.
- DOE82 Department of Energy, Office of Defense Waste and Byproducts Management, "Commingled Uranium Tailings Study," DOE/DP-0011, Washington, D.C., June 30, 1982.
- DOE84 Department of Energy, "United States Mining and Milling Industry", DOE/2-0028, May 1984.
- ELP85 Electric Light and Power, "Uranium Industry Not Viable in 1984, Determines DOE's Harrington", November 1985.
- EPA83a Environmental Protection Agency, "Regulatory Impact Analysis of Environmental Standards for Uranium Mill Tailings at Active Sites", EPA 520/1-82-023, March 1983.
- EPA83b Environmental Protection Agency, "Final Environmental Statement for Standards for the Control of Byproduct Materials from Uranium Ore Processing (40 CFR 192)", (EPA 520/1-83-008-1), Office of Radiation Programs, Washington, D.C., September 1983.
- EPA85 U.S. Environmental Protection Agency, "Draft Document-Estimates of Population Distributions and Tailings Areas Around Licensed Uranium Mill Sites", Office of Radiation Programs, November 1985.
- EPA86 Environmental Protection Agency, "Technical information submitted by letter dated January 27, 1986 from T. R Strong, Head, Radiation Control Section, State of Washington, Department of Social and Health Services, Olympia, Washington to Sheldon Meyers, Acting Director", Office of Radiation Programs, U.S. EPA.
- Ge85 Gerdemann F. W., "Correspondence with PEI Associates, Inc.", Plateau Resources Limited, January 1985.

Ha85 Hardgrove T., Pathfinder Mines Corporation, Correspondence with PEI Associates, Inc., January 1985.

Hi85 Hill C., Minerals Exploration Company, Correspondence with PEI Associates, Inc., January 1985.

Jo80 Johnson T. D., Sohio Western Mining Company Tailings Dam, in: First International Conference on Uranium Mine Disposal, C. O. Brawer, editor, Society of Mining Engineers of AIME, New York, 1980.

Ki80 King K. and Lavander R., Design and Construction of Uranium Disposal Facilities for the Panna Maria Project, Texas, Presented at First International Conference on Uranium Mine Waste Disposal, Vancouver British Columbia, May 19, 1980.

Kr85 Kray E., State of Colorado, Correspondence with PEI Associates, Inc., January 1985.

Ma85 Manka M., Chevron Resources Company, Panna Mana Project, Correspondence with PEI Associates, Inc., February 1985.

Mc85 McClusky J., Cotter Corporation, Correspondence with PEI Associates, Inc., February 1985.

Me85 Medlock R., Bear Creek Uranium, Correspondence with PEI Associates, Inc., February 1985.

NM85 State of New Mexico, Radiation Protection Bureau, Correspondence with PEI Associates, Inc., January 1985.

NRC80 Nuclear Regulatory Commission, Final Generic Environmental Impact Statement on Uranium Milling, NUREG-0706, September 1980.

NRC84 Nuclear Regulatory Commission, Office of State Programs, Directory and Profile of Licensed Uranium-Recovery Facilities, (NREG/CR-2869), Washington, D.C., March 1984.

PNL84 Pacific Northwest Laboratory. Estimated Population Near Uranium Tailings. (PNL-4959). January 1984.

Si85 Simchuk G. J., Pathfinder Mines Corporation, Correspondence with PEI Associates, Inc., February 1985.

WA86 State of Washington, Department of Social and Health Services, Uranium Mills Program, Correspondence with PEI Associates, Inc. January 1986.

Wo85 Wong T., Umetco (Union Carbide), Correspondence with PEI Associates, Inc., February 1985.

Chapter 5: INDUSTRY RADON-222 EMISSION ESTIMATES

5.1 Introduction

This chapter presents a discussion of the methodology used to estimate the quantity of radon-222 emitted from tailings impoundments and evaporation ponds at licensed uranium mills. As mentioned in Chapter 3, ore storage and milling operations emit relatively low amounts of radon-222 compared with the amounts emitted by tailings impoundments. Mills that are on standby generate almost no radon-222 other than that from their tailings impoundments. The quantity of radon-222 emitted annually from each site is estimated both for current conditions (i.e., fraction of tailings area with current water cover) and for anticipated future conditions (i.e., dry tailings). Water cover and tailings moisture content have a major influence in controlling the amount of radon-222 that is released; therefore, dry conditions must be considered in the determination of the potential maximum amount of radon-222 that could be emitted (i.e., future conditions). Emissions are estimated for each tailings impoundment and evaporation pond at each licensed uranium mill except the six mills that have already initiated decommissioning activities and are subject to other Federal standards.

5.2 Estimating Emissions

Estimates of radon-222 emissions are based on an assumed emission rate that equals the specific flux of 1 pCi radon-222/m²s per pCi radium-226/g tailings for dry tailings times the dry area. It has been assumed that tailings that are either saturated with or covered by tailings solution do not emit radon-222. These assumptions were applied to the site-specific data to estimate emissions.

For the specific flux of 1 pCi radon-222/m²s per pCi radium-226/g to be used, both the dry surface area and the radium-226 concentration of the tailings impoundment must be known. The surface area of existing tailings impoundments has been documented previously (EPA83, NRC80). The uranium industry, however, has changed significantly since the compilation of these earlier data bases, as demonstrated by the drop in uranium production (and thus tailings generation), the initiation of decommissioning activities at six mills, and the drying of tailings impoundments at others because they are not in use. To obtain an updated data base, EPA's Office of Radiation Programs completed a study entitled "Estimates of Population Distribution and Tailings Areas Around Licensed Uranium Mill Sites" (EPA85). As discussed in Chapter 4, this document summarizes the results

of a survey the EPA conducted of 22 uranium mill sites in 1985. This survey produced estimates of the total surface area of the tailings impoundments, which includes the area covered by tailings solution, the saturated area, and the dry surface area of tailings. The same information was also compiled for evaporation ponds. These estimates of tailings areas were used as the basis for estimating radon-222 emissions in this report (See Table 4-2 in Chapter 4). This tabulation includes a listing, by state, of each known tailings impoundment and evaporation pond at the licensed mills. The type of impoundment is also identified, i.e., earthen dam, sand tailings dam, or below-grade impoundment. The status of each impoundment (active, standby, or at capacity) is shown, and estimates of the average radium-226 content in the tailings are listed for each mill. The total impoundment and evaporation pond area is 1570 ha (3882 acres), over 50 percent of which is dry. Only four mills with seven tailings impoundments are currently active; 32 tailings impoundments are on a standby basis or have been filled to capacity.

Concentrations of radium-226 present in tailings vary from site to site. The EPA's Final Environmental Impact Statement for Standards for the Control of Byproduct Materials from Uranium Ore Processing listed radium-226 concentrations in tailings for each licensed mill (EPA83). These values were used in this report to estimate emissions of radon-222.

Emissions were estimated for two conditions: current water-cover conditions (as of late summer of 1985) and after drying. Under current conditions, it was assumed that radon-222 was emitted only from dry areas of the tailings impoundments or evaporation ponds. In the estimates of radon-222 emissions, a specific flux of 1 pCi Rn-222/m²s per pCi of Ra-226 per gram of tailings was used for dry tailings and a specific flux of zero, for ponded and saturated tailings. As discussed in Chapter 3, this assumed specific flux calculation has been previously documented and used (NRC80, EPA83). This average conservative flux, which provides an approximate estimate of emissions, is useful when the many other factors affecting the flux, such as tailings moisture content, diffusion factors, and emanation coefficients, are not well known. The following calculation was used to estimate emissions from dry areas:

$$\text{kCi Rn-222/y} = \text{dry area, m}^2 \times 1 \text{ pCi Rn-222/m}^2\text{s per pCi Ra-226/g} \times \text{pCi Ra-226/g} \times 3.15 \times 10^7 \text{ s/y} \times 10^{-15} \text{ kCi/pCi}$$

The radium-226 concentration in picocuries/gram of tailings is shown in Table 5-1. For estimates of emissions after drying, the total tailings area was substituted for the dry tailings area in

Table 5-1. Summary of radon-222 emissions from uranium mill tailings impoundments

Owner/Impoundment	Radon-222 emissions (kCi/y)		
	Current conditions (flux = 1) ^(a)	Current conditions (factored) ^(b)	After drying
<u>Colorado</u>			
Cotter Corp.			
Primary	0.4	0.5	8.4
Secondary	3.0	3.0	3.1
Umetco			
Impoundments 1 & 2	3.8	3.9	4.0
Impoundment 3	1.8	1.8	2.0
Sludge pile	1.2	1.2	1.2
Evaporation pond	0.9	1.0	1.0
<u>New Mexico</u>			
Sohio			
L-Bar	2.9	3.9	8.2
United Nuclear			
Churchrock	2.4	3.2	5.5
Anaconda			
Bluewater 1	19	19	19
Bluewater 2	3.7	3.7	3.7
Bluewater 3	1.9	1.9	1.9
Evaporation ponds	3.8	4.2	13
Kerr-McGee			
Quivira 1	15	17	21
Quivira 2a	4.7	5.6	8.3
Quivira 2b	2.0	2.0	2.2
Quivira 2c	2.1	2.2	2.4
Evaporation ponds	7.5	7.7	29
Homestake			
Homestake 1	5.4	5.8	10
Homestake 2	1.8	1.8	2.2
<u>Texas</u>			
Chevron			
Panna Maria	0.9	1.0	3.1

Table 5-1. Summary of radon-222 emissions from uranium mill tailings impoundments (continued)

Owner/Impoundment	Radon-222 emissions (kCi/y)		
	Current conditions (flux = 1) ^(a)	Current conditions (factored) ^(b)	After drying
<u>Utah</u>			
Umetco			
White Mesa 1	1.5	1.6	2.1
White Mesa 2	2.0	2.1	2.7
White Mesa 3	0.6	0.6	2.4
Rio Algom			
1	2.7	2.8	3.1
2	1.1	1.2	2.3
Atlas			
Moab	6.2	6.3	10
Plateau Resources			
Shootaring Canyon	0.1	0.1	0.2
<u>Washington</u>			
Dawn Mining			
Ford 1, 2, 3	2.9	2.9	2.9
Ford 4	0.3	0.3	0.9
Western Nuclear			
Sherwood	1.8	1.8	2.4
Evaporation pond	-	-	0.4
<u>Wyoming</u>			
Pathfinder			
Gas Hills 1	6.4	6.4	6.6
Gas Hills 2	2.1	2.3	2.9
Gas Hills 3	0.1	0.1	1.2
Gas Hills 4	0.6	0.7	4.8
Western Nuclear			
Split Rock	2.4	2.7	8.6
Umetco			
Gas Hills	6.0	6.0	6.0
A-9 Pit	0.6	0.7	1.0
Leach pile	0.9	0.9	0.9
Evaporation ponds	-	-	0.8

Table 5-1. Summary of radon-222 emissions from uranium mill tailings impoundments (continued)

Owner/Impoundment	Radon-222 emissions (kCi/y)		
	Current conditions (flux = 1) ^(a)	Current conditions (factored) ^(b)	After drying
Rocky Mountain Energy Bear Creek	2.8	3.2	6.5
Pathfinder Shirley Basin	4.1	4.6	18
Minerals Exploration Sweetwater	0.2	0.2	1.3
Totals	129	137	238

(a) Based on a specific flux of 1 pCi Rn-222/m²s per pCi Ra-226 per gram of tailings for dry areas and a flux of zero for ponded and wet areas.

(b) Specific flux of 0.3 pCi Rn-222/m²s per pCi Ra-226 per gram of tailings for wet tailings area, 1 pCi Rn-222/m²s per pCi Ra-226 per gram of tailings for dry area, and zero for ponded areas.

the preceding calculation. The results of the calculations for impoundments at each mill considered in this report are presented in Table 5-1. Total radon-222 emissions are estimated to be 129 kCi/y under current conditions and to rise to about 238 kCi/y after all the areas have dried.

Although a specific flux of 1 pCi radon-222/m²s per pCi radium-226/g tailings is commonly used and recommended by NRC (NRC85) when specific data are lacking, alternative methods of flux estimation are available. One alternative method is to assume that the radon-222 flux from dry areas is 1 pCi radon-222/m² per pCi radium-226/g; zero from ponded areas, as previously discussed; and 0.3 pCi radon-222/m² per pCi radium-226/g for saturated areas instead of zero (NRC80). Estimates of radon-222 emissions made by using this method of calculation indicate 137 kCi/y, as shown in Table 5-1.

Other alternative methods of estimating radon-222 emissions require site-specific data. As discussed in Chapter 3, information on radium-226 and on the moisture content, porosity, density, and emanating power of tailings can be substituted into the diffusion equation to estimate a site-specific flux for each area of a tailings impoundment. An attempt was made to complete such an estimate for each mill in a recent study (PEI85). That study indicated that using a specific flux of 1 pCi radon-222/m²s per pCi radium-226/g tailings for dry areas and zero for ponded and saturated areas resulted in a conservative (high) estimate of radon-222 emissions. Total emissions estimated by using the assumed specific flux were about twice as high as those made using site-specific information. The site-specific information was based on a number of assumptions, however, as not all of the necessary tailings data are currently available at licensed mill sites. Also, estimating radon-222 emissions from tailings after drying would require additional assumptions regarding their physical characteristics. The current data base is not sufficient to allow more accurate calculation of emissions based on site-specific tailings characteristics; therefore, the specific flux (1 pCi radon-222/m²s per pCi radium-226/g) for dry areas and zero for ponded and saturated areas were used in this report. The emission estimates presented herein may be conservative compared with estimates made by other means, but insufficient specific data are available to draw any definite conclusions.

REFERENCES

- EPA83 Environmental Protection Agency, "Final Environmental Impact Statement for Standards for the Control by Byproduct Material from Uranium Ore Processing", EPA 520/1-83-008-1, Office of Radiation Programs, U.S. EPA, Washington, D.C., September 1983.
- EPA85 Environmental Protection Agency, "Estimates of Population Distribution and Tailings Areas Around Licensed Uranium Mill Sites (Draft)" Office of Radiation Programs, Las Vegas Facility, Las Vegas, Nevada, 1985.
- NRC80 Nuclear Regulatory Commission, "Final Generic Environmental Impact Statement on Uranium Milling", NUREG-0706, September 1980.
- NRC85 Nuclear Regulatory Commission, "Methods for Estimating Radioactive and Toxic Airborne Source Terms for Uranium Milling Operations", NUREG/CR-4088, June 1985.
- PEI85 PEI Associates, Inc., "Radon-222 Emissions and Control Practices for Licensed Uranium Mills and Their Associated Tailings Piles", EPA Contract 68-02-3878, June 1985.

Chapter 6: BASELINE INDUSTRY RISK ASSESSMENT

6.1 Introduction

This chapter contains an assessment of the risks of fatal lung cancer caused by radon-222 emissions from uranium tailings impoundments. Two measures of risk are presented: risks to nearby individuals and risks to the total population. The first measure refers to the estimated increased lifetime risk imposed upon individuals who spend their entire lifetime at a location near a tailings impoundment, where the predicted radon-222 concentrations are highest. Risks to nearby individuals are expressed as a probability, i.e., 0.001 (1/1000) or $1E-3$. This means that the increased chance of lung cancer in an exposed person's lifetime is 1 in 1000. Estimates of risks to nearby individuals must be interpreted cautiously, as few people generally spend their whole lives at such locations. The second measure, risks to the total population, refers to all people exposed to radon-222 emissions from all of the licensed uranium mill tailings impoundments. Expressed in terms of the number of fatal cancer cases caused by the amount of radon-222 emitted annually, this provides a measure of the overall public health impact.

An epidemiological approach is used to estimate risks which are based on relative risk from exposures to radon-222 expressed in working level months (WLM). The WLM is in turn related to a concentration of radon-222 decay products, expressed in picocuries/liter. Risks are directly proportional to emissions; therefore, one can estimate the deaths due to radon-222 in the future by assuming that new tailings impoundments will be located in the same general area of existing impoundments.

6.2 Risk Estimates

6.2.1 Nearby Individuals

Individual risks are calculated by using the life table methodology described by Bungler et al. (Bu81). The relative risk projections used for lifetime exposure were based on relative risk coefficients of 1 and 4 percent per WLM for the radiation-induced increase in lung cancer. See discussion in Section 2.3.

The AIRDOS-EPA and DARTAB codes and an assumed radon-222 decay product equilibrium fraction determined as shown in Table 2-4 were used to estimate the increased chance of lung cancer for individuals living near a tailings impoundment and receiving the maximum exposure. Results are shown in Table 6-1. The maximum risk of 2 percent (2E-2) occurs at Anaconda, New Mexico at a distance of 1.5 km from the center of the impoundment.

6.2.2 Regional Population

Collective (population) risks for the region are calculated from the annual collective exposure (person WLM) for the population in the assessment area by a computerized methodology known as AIRDOS-EPA (Mo79). An effective equilibrium fraction of 0.7 is presumed because little collective exposure takes place near the mill.

In this study, population data in the 0- to 5-km and 5- to 80-km regions around each mill were obtained from an earlier detailed study by EPA and are summarized in Chapter 4 (EPA83). Collective exposure calculations expressed in person WLM were performed for each mill by multiplying the estimated concentration in each annular sector by the population in that sector. The parameters used in the AIRDOS-EPA code are shown in Table 6-2. An approximate emission height of 1 meter was assumed in all cases. Meteorological parameters from selected weather stations were used for each mill. Included in this table are the resulting exposure for that mill based on the emission rate and the population near the mill. Estimates of the number of fatal cancers corresponding to this exposure were made by using a risk factor of 3 percent (760 deaths per 10^6 person WLM). These estimates were then multiplied by 1520/760 or 380/760 to adjust to the risk coefficients of 4 and 1 percent, respectively (1520 and 380 deaths per 10^6 person WLM). A summary of the estimated fatal cancers due to radon-222 from existing tailings impoundments is shown in Table 6-3 under the current (partially wet and partially dry) conditions and under entirely dry conditions.

These estimated health effects for the 20 mills considered compare favorably with the previous EPA study (EPA83) for uranium byproduct materials. In the earlier study, a model plant approach was used at 26 sites, and 0.38 and 2.1 deaths were estimated for the 0-5 km and 5-80 km regions, respectively, for post-operational (dry) conditions (Page 6-14 in EPA83).

Table 6-1. Estimated risk of fatal lung cancer from maximum exposure for an individual living near tailings impoundment

State	Mill owner	Maximum lifetime risk to individual ^(b)	Distance ^(a) meters
Colorado	Cotter	3E-4 (8E-5)	2500
	Umetco	8E-3 (2E-3)	750
New Mexico	Kerr-McGee	1E-2 (2E-3)	2500
	Anaconda	2E-2 (5E-3)	1500
	United Nuclear	2E-3 (4E-4)	1500
	Homestake	6E-3 (1E-3)	1500
	Sohio	7E-4 (2E-4)	3500
Texas	Chevron	2E-3 (4E-4)	750
Utah	Umetco	2E-4 (6E-5)	4500
	RioAlgom	3E-3 (7E-4)	750
	Atlas	4E-3 (1E-3)	1500
	Plateau Res.	2E-5 (4E-6)	4500
Washington	Dawn	3E-3 (6E-4)	750
	Western Nuclear	2E-4 (5E-5)	4500
Wyoming	Minerals Exploration	4E-6 (9E-7)	30000
	Pathfinder		
	Gas Hills	2E-3 (6E-4)	2500
	Shirley Basin	9E-5 (2E-5)	15000
	Rocky Mt.	9E-5 (2E-5)	15000
	Umetco	1E-4 (3E-5)	15000
Western Nuclear	2E-3 (5E-4)	750	

(a) Distance from center of a homogenous circular equivalent impoundment.

(b) The value in the first column is based on a risk factor of 1520 deaths/10⁶ person WLM, and the values in parentheses are based on 380 deaths/10⁶ person WLM.

Table 6-2. AIRDOS-EPA code inputs and estimated risks

State	Company	Atmospheric mixing depth (m)	AIRDOS code inputs		Approximate impoundment area (ha)	Deaths/year ^a	
			Precipitation (cm/y)	Ambient temperature (°C)		0-5 km	5-80 km
Colorado	Cotter	700	38.8	10	10	1.2E-2	5.2E-2
	Umetco	700	40.2	10	50	2.3E-2	2.1E-2
New Mexico	Kerr-McGee	800	29.1	11	200	2.0E-4	1.9E-1
	Anaconda	800	27.0	11	100	5.0E-2	2.7E-1
	United Nuclear	800	29.1	11	30	1.7E-3	1.8E-2
	Homestake	800	27.0	11	60	1.5E-2	8.6E-2
	Sohio	800	27.0	11	20	7.6E-4	4.3E-2
Texas	Chevron	1000	76.6	21	10	6.7E-4	2.6E-2
Utah	Umetco	700	22.2	13	40	1.8E-5	6.1E-3
	RioAlgom	700	22.2	13	20	2.2E-3	4.6E-3
	Atlas	700	22.1	13	40	1.8E-2	1.4E-2
	Plateau Res.	700	25.2	13	2	3.3E-5	6.4E-6
Washington	Dawn	600	54.2	9	40	3.5E-3	3.0E-2
	Western Nuclear	600	54.2	9	30	8.7E-5	1.2E-2
Wyoming	Minerals Explora- tion	700	27.3	6	3	-	8.3E-5
	Pathfinder						
	Gas Hills	700	28.0	6	70	1.9E-3	2.9E-3
	Shirley Basin	700	29.6	6	20	-	4.6E-3
	Rocky Mt.	700	35.4	6	20	-	3.7E-3
	Umetco	700	33.9	6	80	-	2.2E-3
Western Nuclear	700	28.0	6	20	1.4E-3	5.2E-4	

(a) Based on 760 deaths per 10^6 person WLM.

(b) Zero population in the 0-5 km region.

Table 6-3. Summary of regional health effects from existing tailings impoundments

<u>Condition of tailings</u>	<u>Emissions</u> ^(a) <u>(kCi/y)</u>	<u>Committed fatal cancers per year</u> ^(b)		
		0-5 km	5-80 km	0-80 km
Current	129	0.3 (0.1)	1.6 (0.4)	1.8 (0.5)
All dry	238	0.4 (0.1)	2.9 (0.7)	3.3 (0.8)

(a) Based on radon-222 flux of 1 pCi/m² per pCi of Ra-226 per gram of tailings.

(b) Values in first column are based on 1520 deaths due to lung cancer per 10⁶ person WLM. The values in parentheses are based on 380 deaths per 10⁶ person WLM.

6.2.3 National

Radon-222 released from mills can be transported beyond the 80-km regional cutoff. A trajectory dispersion model developed by NOAA (NRC79) has been used to estimate the national impact of radon-222 releases. The model yields radon-222 concentrations (in picocuries per liter) in air, which are then converted to decay product exposures by assuming an effective equilibrium fraction of 0.7. National annual collective exposures (person WLM) are calculated for distances beyond the 80-km regional limit for a total population of 200 million persons. This model was used in a previous EPA study on byproduct material from uranium ore processing (EPA83). Inasmuch as all mills are still in the same location, the results of this earlier study were used to estimate current national health effects by ratioing the estimated deaths to the current emission estimates and adjusting for the revised risk factor ranges. The calculations are shown below and summarized in Table 6-4 (a).

$$\frac{2.47 \text{ deaths}}{202.7 \text{ kCi/y}} \times 129 \text{ kCi/y} \times \frac{1520}{760} = 3.1 \text{ deaths/y}$$

$$\frac{2.47 \text{ deaths}}{202.7 \text{ kCi/y}} \times 129 \text{ kCi/y} \times \frac{380}{760} = 0.8 \text{ death/y}$$

For the dry tailings condition with emissions of 238 kCi/y, the corresponding values are 5.8 and 1.4 deaths per year.

(a) The 2.47 deaths from emissions of 202.7 kCi/y are from EPA's 1983 report and were based on a risk of 760 deaths per 10^6 person WLM.

Table 6-4. Summary of health effects beyond the 80-km region from tailings impoundments

<u>Condition of tailings</u>	<u>Emissions (kCi/y)</u>	<u>Committed fatal cancers per year</u> (a)
Current	129	3.1 (0.8)
All dry	238	5.7 (1.4)

(a) Values in first column are based on 1520 deaths due to lung cancer per 10^6 person WLM. The values in parentheses are based on 380 deaths per 10^6 person WLM.

The estimated health effects from existing impoundments is shown in Table 6-5. This summary shows that about 3 fatal cancers per year can be attributed to tailings impoundments in their current conditions, and this could increase to 6 deaths per year if the impoundments dried and emissions increased.

6.2.4 Risks from New Tailings Impoundments

Radon-222 emissions will not increase greatly until the current impoundments reach capacity and new impoundments are built. The need for new impoundments is directly related to industry growth. The health effects caused by new impoundments may be estimated by assuming a direct proportion of effects to emissions. This procedure assumes that new impoundments will be located in the same geographical area as the existing impoundments and will have the same impact on surrounding populations. Emissions from model new tailings impoundments are estimated in Chapter 7 and will vary with the design and work practice used.

Table 6-5. Summary of fatal cancers from current tailings impoundments

<u>Condition of tailings</u>	<u>Fatal cancers per year</u> ^(a)			
	0-5 km	5-80 km	National	Total
Current	0.3 (0.1)	1.6 (0.4)	3.1 (0.8)	4.9 (1.2)
Dry	0.4 (0.1)	2.9 (0.7)	5.7 (1.4)	9.0 (2.3)

(a) Values in first column are based on 1520 deaths due to lung cancer per 10^6 person WLM. The values in parentheses are based on 380 deaths per 10^6 person WLM.

REFERENCES

- Bu81 Bunger B., Cook J. R., and Barrick M. K., "Life Table Methodology for Evaluating Radiation Risk: An Application Based on Occupational Exposure", *Health Physics* 40, 439-455, 1981.
- EPA83 Environmental Protection Agency, "Final Environmental Impact Statement for Standards for the Control of Byproduct Materials from Uranium Ore Processing (40 CFR 192), Volume I", EPA 520/1-83-008-1, Office of Radiation Programs, USEPA, Washington, D.C., 1983.
- Mo79 Moore R. E., Baes C. F. III, McDowell-Boyer L. M., Watson A. P., Hoffman F. O., Pleasant J. C., and Miller C. W., "AIRDOS-EPA: A Computerized Methodology for Estimating Environmental Concentrations and Doses to Man from Airborne Releases of Radionuclides", ORNL-5532, Oak Ridge National Laboratory, Oak Ridge, Tennessee, 1979.
- NRC79 Nuclear Regulatory Commission, "Draft Generic Environmental Impact Statement on Uranium Milling, Volume II", NUREG-0511, USNRC, Washington, D.C., 1979.

Chapter 7: RADON-222 CONTROL TECHNIQUES

The reduction of radon-222 emissions at licensed uranium mill sites is accomplished most effectively by reducing the emissions from the tailings disposal area. Radon-222 emissions from the balance of the milling circuit are relatively small and are not easily controlled. At mills that are not operating and are on a standby basis, almost all of the radon-222 emissions come from the tailings disposal area.

This chapter is concerned with control techniques that can be applied to licensed uranium mill tailings impoundments to reduce radon-222 emissions. A general discussion of radon-222 control techniques is followed by more detailed discussion of controls for existing and new impoundments.

Radon-222 emissions from uranium mill tailings can be controlled most easily by keeping the tailings covered with water or by covering them with earthen material. At new tailings impoundments, phased disposal of the tailings or continuous disposal by dewatering and immediate covering represent systematic ways of controlling radon-222 emissions using water or earth covers. Extraction of radium-226 from the tailings, chemical fixation, and sintering of tailings have been explored as means of reducing radon-222 emissions, but they have not been applied on a large scale and they appear to be too costly for general application (NRC80).

The applicability and effectiveness of control techniques depend primarily on the design of the mill tailings disposal area and the mill's operating schedule. Thus, the control techniques can be broadly classified as applicable to (1) existing tailings disposal areas at existing uranium mills, and (2) new tailings disposal areas at either new or existing uranium mills.

7.1 Description of Control Practices

The most effective way of controlling radon-222 emissions is to cover the radium-bearing tailings with an impervious material. Earth and water are the cover materials most commonly used and are effective in reducing radon-222 emissions. These cover materials retard the movement of radon-222 long enough for it to decay in the cover material; thus, the decay products remain in the cover.

7.1.1 Earth Covers

Covering the dried beach area with earthen materials has been used to control dust and radon-222 emissions at inactive tailings impoundments. The depth of earth required for a given amount of control varies with the type of earth and the rate at which radon-222 emanates from the bare tailings.

Earth cover restricts the diffusion of radon-222 long enough so that it will decay in the cover material. Radon-222 diffusion through earth is a complex phenomenon affected by processes such as molecular diffusion, described mathematically by Fick's law. These complex diffusion parameters have been evaluated by Rogers and Nielson (Ro81). They determined that diffusion depends greatly on the porosity and moisture content of the medium through which it occurs. Ideally, the diffusion coefficient should be measured experimentally for a given earth cover at its ambient moisture content and expected compaction level. This coefficient can, however, be estimated based on the moisture content and porosity of the material. Clay soils have superior moisture retention (9 to 12 percent moisture) and are best for covering tailings; clay soils are found in the uranium milling regions of Colorado, New Mexico, Utah, and Wyoming (Ro81).

Cover thickness may be calculated by using the same diffusion equations that apply to emissions from uncovered tailings as shown in the following equations (Ro84):

$$J_c = J_t \exp(-b_c x_c)$$

where J_c is the flux through cover ($\text{pCi}/\text{m}^2\text{s}$); J_t is the flux through tailings ($\text{pCi}/\text{m}^2\text{s}$); b_c is $(\lambda/D_c)^{1/2}$; λ is the radon-222 decay constant ($2.1 \times 10^{-6}/\text{s}$); D_c is the diffusion coefficient of cover, $0.07 \exp[-4(m - mp^2 + m^5)]$; m is the moisture saturation fraction [$0.01 M(1/\rho - 1/g)^{-1}$]; M is the moisture content of cover material (percent dry weight); ρ is the bulk density (g/cm^3); g is the specific gravity (g/cm^3); p is the porosity ($1 - \rho/g$); and x_c is the depth of cover material (cm).

This simplified equation assumes that the physical parameters of the cover material, such as its density, specific gravity, moisture content, and porosity, are similar to those of the tailings, and that the tailings are sufficiently thick so that other terms approach a value of one. The flux through the cover material may be estimated by substituting values for the cover depth and the uncovered tailings flux.

Effectiveness and Cost

The approximate effectiveness of various types of earth cover in reducing radon-222 emissions is shown in Figure 7-1. The application of almost any type of earth will initially achieve a rapid decrease in radon-222 emissions. One meter's depth of high-moisture-content earth such as clay will reduce radon-222 emissions by about 90 percent. In Figure 7-1 the earth types are categorized by their "half-value layer" (HVL). The HVL is that thickness of cover material (earth) that reduces the radon-222 flux to one-half its uncovered value. High-moisture content earth provides greater radon-222 emission reduction because of its smaller diffusion coefficients and its lower HVL values. The approximate reduction in radon-222 emissions achieved by applying selected types of earth at 0.5m, 1m, 2m, and 3 meter depths is shown in Table 7-1.

In practice, earthen cover designs must take into account uncertainties in the measurements of the properties of the specific cover materials used, the tailings to be covered, and especially the predicted long-term values of equilibrium moisture content for the specific location. Predicting long-term moisture content requires specific knowledge of the earthen cover to be used and the climatic conditions (Ha84, Ge84). Proper consideration of these factors at the design stage help ensure that radon-222 emissions remain constant over the long term. In predicting reductions in radon-222 flux, uncertainty increases when the required radon-222 emission limit is very low.

The cost of applying earth covers varies widely with location of the tailings impoundment, its layout, and availability of earth. Costs also depend on the size and topography of the disposal site, its surroundings, the amount of earth required, and the hauling distance. Another factor affecting the costs of cover material is ease of excavation and the type of excavating equipment used. In general, the more difficult the excavation, the more elaborate and expensive the equipment is and the higher the cost. The availability of such materials as clay will also affect costs. Large deposits of bentonite and similar clays are found in Wyoming and Utah, and smaller deposits are found in all the Western States. If the necessary materials are readily available locally, no incremental costs would be incurred; if they must be purchased or hauled, costs could increase significantly. Cost factors for earth cover application are given in Table 7-2, and more detailed cost factors are presented in Appendix B. These are direct costs, and they do not include indirect costs such as engineering design and permit costs, insurance, or a contingency. Indirect costs would add approximately 30 percent to the direct charges.

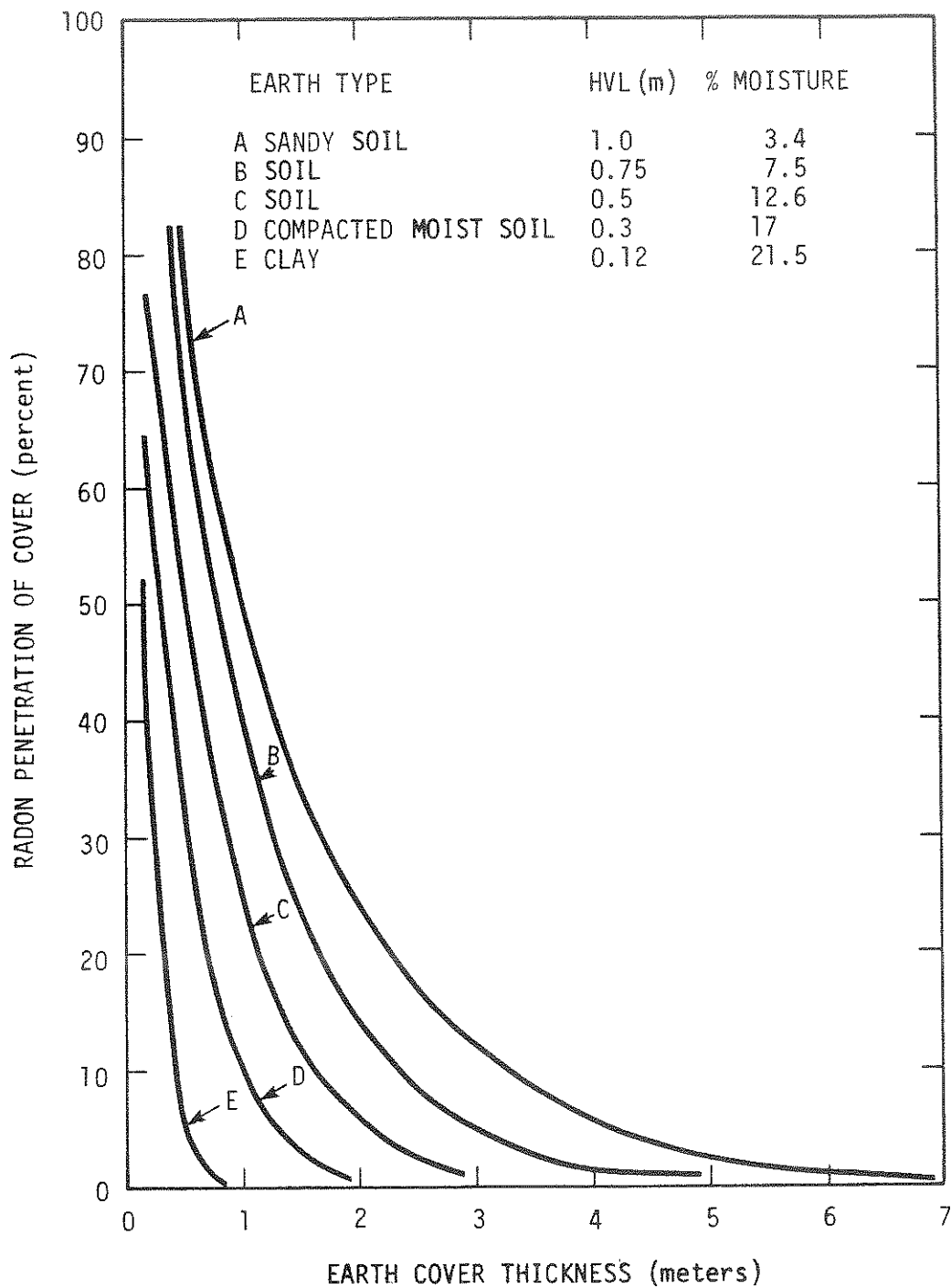

Figure 7-1. Changes in radon-222 penetration with earth cover thickness. (adapted from EPA83)

Table 7-1. Percentage reduction in radon-222 emissions attained by applying various types of earth cover

Earth type ^(a)	HVL(m)	Depth of earth cover (m)			
		0.5	1.0	2.0	3.0
A	1.0	29	50	75	88
B	0.75	37	60	84	94
C	0.5	50	75	94	98
D	0.3	68	90	99	>99
E	0.12	94	>99	>99	>99

(a) See Figure 7-1.

Table 7-2. Summary of unit costs for estimating earth cover costs^(a)

Task	Unit cost (\$)
Grading, self-propelled scraper, 1000-ft haul	1.16/yd ³
Excavation, elevating scraper, 5000-ft haul	2.46/yd ³
Compaction, vibrating	1.00/yd ³
Excavation, front-end loader, truck-loaded	0.84/yd ³
Hauling, 12-yd dump truck, 2-mile round trip	2.35/yd ³
Fencing, 6-ft, aluminized steel	11.30/linear ft
Riprap, machine-placed slope protection	21.00/yd ³
Borrow, bank-run gravel	6.60/yd ³

(a) Building Construction Cost Data 1985, R. S. Means Co., Inc., 43rd Annual Edition, 1984.

Based on the cost factors and the required earth thickness shown in Figure 7-1, the resulting total costs per hectare for earth cover can be estimated (as shown in Table 7-3) for selected emission or flux levels and a bare tailings radon-222 emission rate of 280 pCi/m²s. These costs only take into account the earth moving and placement costs; they do not include any indirect charges or final closure costs, such as riprap or reclaiming borrow pits. They are presented to show the variation in costs among the different types of soil.

For a model 50-ha (124-acre) tailings impoundment, the approximate direct earth moving cost to achieve a 64 percent reduction (from 280 to 100 pCi/m²s) is 5.2×10^6 (50 ha x \$105,000/ha = \$5,250,000) with a fairly dry type A earth and 1.4×10^6 for a more moist type D earth.

Earth cover is applied to dry tailings with conventional earth-moving equipment and engineering practices. However, some areas, especially the sloped sides of dams constructed of coarse tailings, may be difficult to cover without recontouring the pile. Dams constructed of coarse tailings are located at six mill sites, mainly in New Mexico. The slope of the sides of these dams is 2:1 or steeper. Some of these dams have heights of 100 ft or more. These sloped areas represent about 8 percent of the total tailings area. At least one site, Uravan in Colorado, has applied a partial earth cover to the sloped sides of dams constructed of tailings, which would indicate that this is a feasible practice.

7.1.2 Water Cover

Maintaining a water cover over tailings reduces radon-222 emissions. The degree of radon-222 control increases slightly with the depth of the water. Factors affecting this practice include the mill water recirculation rate (if any), evaporation and precipitation rates, impoundment construction and slope, phreatic levels, ground-water contamination potential, and dike or dam stability. Some above-ground tailings impoundments minimize the depth of water to reduce seepage and possible ground-water contamination by draining the water through an overflow pipe to a separate evaporation pond. All uranium mill surface impoundments are subject to ground-water concentration standards as specified in 40 CFR Subpart D 192.32 and incorporated in NRC criteria for tailings impoundments (10 CFR 40, Appendix A). These strict ground-water contamination standards will frequently determine the type of impoundment design and degree of water cover maintained in an active area. An impoundment liner and ground-water monitoring programs will be required for new installations.

Table 7-3. Earth moving and placement costs (thousands of dollars per hectare)^(a) of attenuating radon-222 as a function of thickness (meters of different soils) and type of earth

Final flux ^(c) (pCi/m ² s)	Earth Type ^(b)									
	<u>A</u>		<u>B</u>		<u>C</u>		<u>D</u>		<u>E</u>	
	Cost	Thickness	Cost	Thickness	Cost	Thickness	Cost	Thickness	Cost	Thickness
20	267	3.81	200	2.86	133	1.90	80	1.14	32	0.46
50	174	2.49	130	1.86	87	1.24	52	0.75	21	0.30
100	104	1.49	78	1.11	52	0.74	31	0.45	12	0.18
200	34	0.49	25	0.36	17	0.24	10	0.15	4	0.06

(a) Cost basis: \$7.00/m³ (\$5.35/yd³) of soil cover material; includes excavating (\$0.84/yd³), hauling (\$2.35/yd³), spreading (\$1.16/yd³), and compacting (\$1.00/yd³), in 1985 dollars.

(b) See Figure 7-1.

(c) Based on initial radon-222 emission rate of 280 pCi/m²s.

Effectiveness and Cost

The diffusion coefficient of water is very low (1.1×10^{-5} cm²/s), about one-thousandth of that of soil with a 9 percent moisture content. Thus, water is an effective barrier for radon-222. In shallow areas, the release of radon-222 dissolved in water is increased by thermal gradients and wave motion, and emissions approach those of saturated tailings. Increased radium-226 content in the water reduces its overall effectiveness in controlling radon-222 because the solution also releases radon-222. For a water depth less than 1 meter, the flux rate is similar to that of saturated tailings and may be estimated by Equation 3-1 as presented in Section 3. Water-covered tailings have a radon-222 flux of about 0.02 pCi/m²s per pCi of radium-226 per gram of tailings compared with a dry tailings flux of about 1 pCi/m²s per pCi of radium-226 per gram, or a radon-222 reduction efficiency of about 98 percent (PEI85). Emission estimates of zero are frequently used for ponded and saturated areas, and that assumption is used throughout this report (Ha85) (EPA83).

If a pond is initially designed and built to maintain a water cover, there is no added cost for this form of radon-222 control. Continued monitoring is required to determine if any seepage is occurring through the dam or sides, and ground-water samples may be required periodically as a check for contamination.

7.1.3 Water Spraying

Water (or tailings liquid) sprays can be used to maintain a higher level of moisture in the tailings beach areas. This reduces fugitive dust emissions and may reduce the diffusion of radon-222 through the tailings; however, ground-water contamination may be increased at some sites. The effectiveness of this method varies with the moisture content of the tailings. As shown in Figure 7-2, the radon-222 emanation coefficient initially increases with increasing moisture content up to about 5 to 10 weight percent moisture and then remains fairly constant. Thus, if water is applied to a very dry beach area, radon-222 emissions may initially increase because of a larger emanation coefficient. As the moisture increases, however, the diffusion coefficient will decrease. These mechanisms (both affecting radon-222 emissions) "compete" at low moisture levels. Whereas some reports (NRC80) estimate that wetting can achieve an overall radon-222 reduction of 20 percent, others (ST82) have stated that by wetting tailings at low moisture levels, a larger emanation coefficient may outweigh the effects of a lower diffusion coefficient and result in increased emissions at low moisture contents. The overall

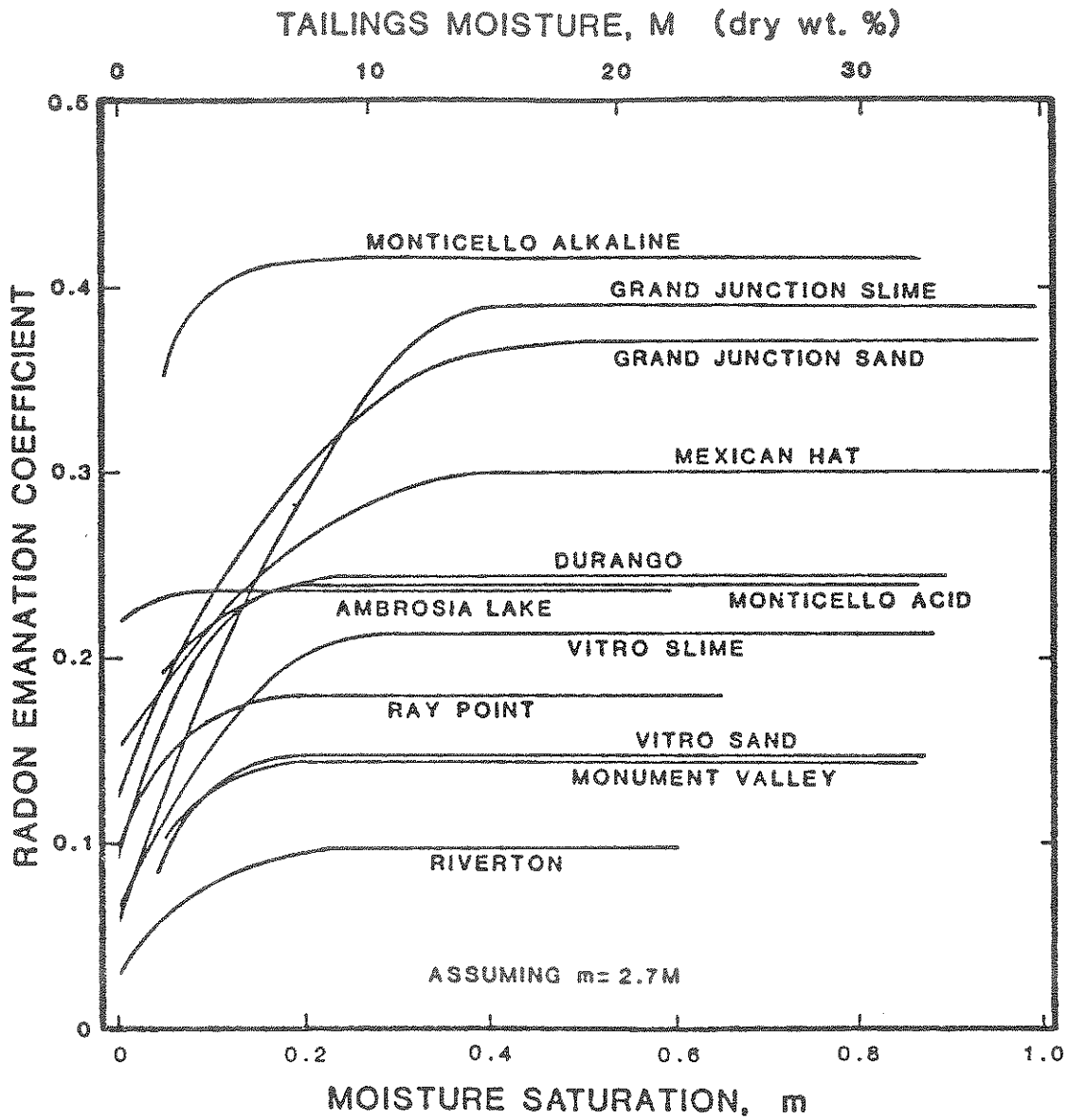

Figure 7-2. Radon emanation coefficients for tailings samples (Ro84).

feasibility of wetting to achieve significant radon-222 reductions is questionable, especially in arid regions, because large quantities of liquid are required to maintain high moisture levels.

7.1.4 Other Control Techniques

Several other radon-222 control techniques have been evaluated. Although none of these methods has been applied on a large scale, they are described briefly here as part of this Background Information Document.

Synthetic Covers

Synthetic material, such as polyethylene sheet, can reduce radon-222 emissions if carefully placed on dry beach areas and sealed. Diffusion coefficients of less than 10^{-6} cm²/s have been measured for synthetic materials (Ro81). Such covering could be used on portions of the tailings on a temporary basis and then removed or covered with fresh tailings. Such a barrier also would aid, at least temporarily, in the control of radon-222 if a soil cover material were subsequently applied. The overall effectiveness of synthetic covers is not known because leaks occur around the edges and at seams and breaks. Synthetic covers have a limited life, especially in dry, sunny, windy areas, and will not provide a long-term barrier to radon-222. The cost of installing polyethylene material is about \$0.01/ft² per mil of thickness or \$0.50/ft² for 50 mil material, which is equivalent to about \$53,800/ha (\$21,750/acre).

Chemical stabilization sprays that form coatings on the dry tailings are effective for controlling dust, but they are not useful for suppressing radon-222 because they do not provide an impermeable cover.

Asphalt Covers

Asphalt cover systems have been proposed as a radon-222 control technique because such systems exhibit very low radon-222 diffusion coefficients. The Pacific Northwest Laboratory (PNL) has investigated controlling the release of radon-222 through use of asphalt emulsion covers for several years for DOE's Uranium Mill Tailings Remedial Action Project (UMTRAP). Results have shown asphalt emulsion cover systems to be effective at substantially reducing radon-222 emissions, and field tests indicate that such systems have the properties necessary for long-term effectiveness and stability. Of the various types of asphalt cover systems that were researched, an asphalt emulsion admix seal was found to be the most effective (Ha84, Ba84).

Costs of applying a full-scale asphalt cover were estimated to be \$24.20/m (\$20.23/yd) in 1981 dollars or \$100,000/acre (Ba84). These cost estimates are probably applicable to relatively flat sites. Existing uranium mill tailings impoundments may have to be regraded before these techniques could be applied. Cover protection, in the form of gravel or revegetation, above an earthen cover applied over the asphalt radon-222 barrier to protect it may also have to be considered. Asphalt cover systems could prove to be economically competitive with earthen covers at some existing sites. Site-specific evaluations would have to be performed that analyzed the amount of earth required as well as its availability and cost versus the cost of applying an asphalt cover system. An ample supply of earthen material should be available as a final cover of new uranium mill tailings impoundments that are constructed below or partially below grade; such a supply would probably make an asphalt cover system economically unattractive.

Thermal Stabilization

Thermal stabilization is a process in which tailings are sintered at high temperatures. The Los Alamos National Laboratory has conducted a series of tests on tailings from four different inactive mill sites where tailings were sintered at temperatures ranging from 500° to 1200°C (Dr81).

The results show that thermal stabilization effectively prevented the release (emanation) of radon-222 from tailings. The authors note, however, that before thermal stabilization can be considered as a practical disposal method, information is needed on the following:

- (1) The long-term stability of the sintered material exposed to physical degradation and chemical attack (e.g., solubility of new minerals and amorphous material found in thermally stabilized tailings).
- (2) The interactions of the tailings with the refractory materials lining a kiln.
- (3) The gaseous and particulate emissions produced during sintering of tailings.
- (4) Revised engineering and economic analysis as more information is developed.

Gamma radiation is still released after sintering; therefore, protection against the misuse of sintered tailings would be required. Although the potential health risk from external gamma radiation is not as great as that from the radon-222 decay products, it can produce unacceptably high exposure levels in and around occupied buildings. Also, the potential for ground-water contamination may require the use of liners in a disposal area.

Chemical Processing

The Los Alamos National Laboratory has also studied various chemical processes for the extraction of thorium-230 and radium-226 (precursors of radon-222) from the tailings along with other minerals (Wm81). After their removal from the tailings, the thorium-230 and radium-226 can be concentrated and fixed in a matrix such as asphalt or concrete. This greatly reduces the volume of these radioactive materials and permits disposal with a higher degree of isolation than economically achievable with tailings.

The major question regarding chemical extraction is whether it reduces the thorium-230 and radium-226 values in the stripped tailings to safe levels. If processing efficiencies of 80 percent to 90 percent were attained, radium-226 concentrations in tailings would still be in the range of 30 to 60 pCi/g. Thus, careful disposal of the stripped tailings would still be required to prevent misuse. Another disadvantage of chemical processing is the high cost, although some of the costs might be recovered from the sale of other minerals recovered in the process (Th81).

Soil Cement Covers

A mixture of soil and portland cement, called soil cement, is widely used for stabilizing and conditioning soils (PC79). The aggregate sizes of tailings appear suitable for producing soil cement, which is relatively tough, withstands freeze/thaw cycles, and has a compressive strength of 300 to 800 psi. When combined in a disposal system with a 1-meter earth cover over it, soil (tailings) cement would likely provide reasonable resistance to erosion and intrusion, could be expected to reduce radon-222 releases, and would shield against penetrating radiation. The costs are expected to be comparable to those of thick earth covers.

The long-term performance of soil cement is unknown, especially as tailings impoundments shift or subside with age. Also, soil cement cracks at intervals when placed over large surface areas. The importance of this cracking on the effectiveness of soil cement for radon-222 control has not been evaluated.

Deep-Mine Disposal

Disposal of tailings in worked-out deep mines offers several advantages and disadvantages compared with surface disposal options. The probability of intrusion into and misuse of tailings in a deep mine is much less than that of surface

disposal. Radon-222 releases to the atmosphere would be reduced, as would erosion and external radiation. This method, however, has potential for ground-water contamination problems. Also, it could be costly, depending on the mine location and the controls required to guard against potential ground-water contamination.

7.2 Control Practices Applicable to Existing Tailings Impoundments

Control practices that are applicable to existing tailings impoundments are limited to application of earthen covers, or possibly asphalt mixtures, to dry areas, and maintaining or expanding the area of tailings covered by water (if it were determined that ground-water impacts would not result). Either interim (i.e., short-term) or final (i.e., long-term) controls could be applied. Interim control is the application of a cover that reduces radon-222 emissions but that does not meet the requirements of final reclamation. Standards for final reclamation include requirements for reducing average radon-222 emissions to 20 pCi/m²s and for long-term (1000 y) stability and protection against misuse.

7.2.1 Interim Controls

Application of an interim earthen cover on the dry portions of tailings impoundments could reduce radon-222 emissions over the period of licensed operation and prior to final reclamation. For example, a 0.3 m (1 ft) or 1 m (3.3 ft) thick earth cover having 8 percent moisture content would theoretically reduce radon-222 emissions by about 25 and 62 percent, respectively (Table 7-1). There are many unknowns regarding the effectiveness, applicability, timing, and operational aspects of interim cover. These items are discussed below and more fully in Appendix C.

The operational status (at capacity, standby, or active) and the type of construction (dams constructed of coarse tailings, earth dams, or below-grade lined impoundments) control the extent to which interim cover could be applied. Interim cover could be applied immediately to most dry areas of existing impoundments (excluding dams). Currently, about 50 percent of the total area of existing impoundments is dry (Table 4-2). Ten existing impoundments have been filled to capacity. These impoundments represent about 14 percent of the total area and about 25 percent of the total area that is currently dry (the dry areas are the major sources of radon-222 emissions as discussed in Chapter 3). Impoundments that are at capacity could be covered immediately because they have already dried and because they will never be used again for tailings disposal.

Site characteristics that control or prohibit the applicability of interim cover include impoundment design and construction; dam height; stability; phreatic level; permeability; site water balance; evaporation rates; presence and location of movement monitors, monitor wells or piezometers; and availability of suitable earth cover material. Operating factors such as expected uranium production rate, length and number of standby periods, impoundment capacity, and expected mill life also affect the applicability of interim cover.

At active impoundments, only those areas that are not to be used further would be covered. Which areas could be covered are a function of expected mill life and quantity of tailings, the size of tailings impoundment, the level of tailings generated (percentage of capacity), and the operational practices used to construct the impoundment. In addition, a source of cover material must be obtained and a technique must be developed for hauling, dumping, spreading and compacting the earth cover onto the beach area. Limited access to the tailings area and the stability of the dam would affect the size of the equipment that can be used to transport and spread the cover material. Metal gratings or timbers may be required to distribute vehicle wheel loads on the dike or dried beach area to facilitate the use of earthmoving equipment. These site-specific factors would increase earthmoving costs.

Of the existing tailings impoundments, 11 have sand tailings dams and are above ground, 22 have earthen dams and are above ground (4 of these are lined), and 5 are below grade and lined. Currently, all tailings impoundments at licensed mills must limit radon-222 to as low as reasonably achievable (ALARA) levels, as specified in 40 CFR 192. Work practices or emission limits are not specified, however. Mills that are on standby and have begun or are about to begin the decommissioning process will eventually cover the tailings areas and reduce emissions to 20 pCi/m²s as required by Federal regulations. Mills that wish to retain their operating licenses do not have to begin their final decommissioning process, but they could take some interim actions to minimize radon-222 emissions. Interim cover as a means of reducing radon-222 emissions to air from operational tailings impoundments is difficult to apply as new tailings beach areas are continuously being formed.

Covering the currently dry beach areas, excluding dams, with 1 meter of earth and maintaining the current water cover on the ponded and wet beach areas would reduce radon-222 emissions from 129 kCi/y to about 69 kCi/y, a reduction of 46 percent, ^(a) at a cost of about \$63 x 10⁶ (1985 dollars). Additional details regarding the applicability, timing, and operational aspects of interim cover are discussed in Appendix C.

(a) Based on soil with 7.5 percent moisture content.

The feasibility of maintaining water cover is limited because of potential site-specific factors such as seepage, ground-water contamination, and dam stability problems. For an existing above-ground tailings impoundment, many site-specific factors cannot be readily changed, and the feasibility of water cover is limited, mainly because of dike stability and seepage. Also, during extended standby periods, maintaining the water cover would be difficult, especially in arid areas. Ideally, the impoundment would be lined and constructed to allow approximately a 1-meter depth of water cover and have an overflow pipe leading to an adjacent evaporation pond and/or for recycling to the mill. The use of water cover would require maintaining sufficient freeboard to prevent overflow and the monitoring of ground water. Eight impoundments are lined, representing 11 percent of the total tailings area and 9 percent of the dry exposed tailings areas. Five of these impoundments are below grade. The water cover on these lined impoundments could be increased to reduce radon-222 emissions from the 200 acres of dry tailings that they currently contain. The potential for increased ground-water contamination, however, would limit the use of this radon-222 control option.

7.2.2 Final Reclamation

If all existing impoundments were allowed to dry, and were covered with enough earth to achieve a flux of $20 \text{ pCi/m}^2\text{s}$, the total radon-222 emissions would be reduced to 8 kCi/y . The cost would be about $\$660 \times 10^6$. For ongoing milling operations, new tailings impoundments would be built and work practices would be instituted to reduce emissions.

Bringing existing impoundments to final reclamation entails substantially more effort than effecting interim control measures. After the sand tailings dams have dried, they are recontoured to 5:1 (H:V) slopes for long-term stability. Earth dams were not recontoured in the cost estimates presented in this section. The cost of enough earth (8% moisture) to attenuate the radon-222 flux to $20 \text{ pCi/m}^2\text{s}$ is placed over the tailings. The earthen cap is covered with gravel to protect the top surface, and the riprap is used to protect earth-covered side slopes from erosion. The cost estimate also includes reclaiming the on-site borrow pits that are assumed to be the source of earthen cover material.

7.2.3 Comparison of Interim and Final Controls

Estimates of the reduction in emissions, the avoided fatal cancers, and the costs of applying earth cover to achieve various control alternatives are summarized in Table 7-4. Covering the

Table 7-4. Benefits and costs of alternatives that apply earth cover to existing tailings impoundments

Alternative	Radon-222 emissions (kCi/y)		Avoided fatal cancers/y ^(a)		Cost ^(b) (\$ x 10 ⁶)
	Current	After	0-80 km	National	
Cease use of current impoundments, allow to dry and apply final cover.	129	8	1.7(0.5)	2.9(0.7)	660
Cover current dry areas with 1 m of earth.	129	69	0.8(0.2)	1.5(0.4)	63

(a) Values are based on 1520 deaths due to lung cancer per 10⁶ person WLM. The values in parentheses are based on 380 deaths per 10⁶ person WLM.

(b) Total cost, including indirect charges. Final cover includes earth required to achieve 20 pCi/m²s, regrading sand tailings dams to 5:1 (H:V) slope, riprap on sides, and gravel on top of impoundments (1985 dollars).

currently dry areas, excluding dams and evaporation ponds, with a meter of earth achieves a theoretical estimated reduction in emissions of 46 percent at a cost of $\$63 \times 10^6$ (1985 dollars) and prevents from 0.6 to 2.3 cancers per year (based on a range of 380 to 1520 deaths per 10^6 person WLM). Total avoided cancers are the sum of avoided cancers in the 0-80 km region and the national (i.e., outside the 0-80 km region). An estimated emission reduction of 94 percent can be achieved by applying sufficient cover to achieve 20 pCi/m²s; this would cost $\$660 \times 10^6$ (1985 dollars) and prevent from 1.2 to 4.6 cancers each year. (These cost estimates are for the control practice only and do not include the cost of establishing new impoundments. In addition, these estimates have not been discounted.) This comparison shows one point in time only. It does not reflect reapplications of interim cover required after restarting of operations at specific sites or changes in emissions due to interim cover deterioration. Annual maintenance costs that would occur over time are also not included.

7.3 Control Practices Applicable to New Tailings Impoundments

New tailings-disposal impoundments at uranium mills can be designed to incorporate radon-222 control measures. Three different kinds of new model impoundments are considered: single-cell, phased disposal, and continuous disposal of dewatered tailings. Descriptions of radon-222 emissions and estimated costs of the three types of new model tailings impoundments are presented in the following sections.

Below-grade impoundments are the NRC's preference, as this method minimizes potential for windblown emissions and water erosion and eliminates the potential for dam failure (NRC80). Although below-grade disposal is preferable, well-designed and operated above-grade tailings impoundments can also provide adequate safety and be licensed by the NRC.

7.3.1 Single-Cell Tailings Impoundment

New tailings disposal areas must conform with Federal regulations (40 CFR 190 and 192 and 10 CFR 40) for prevention of ground-water contamination and airborne particulate emissions. New impoundments will also be designed to facilitate final closure as required by current Federal Standards. New tailings areas will have synthetic liners, will probably be built below or partially below grade, and will have earthen dams or embankments. A means for dewatering the tailings at closure also should be incorporated. This basic layout is amenable to maintaining a water cover over nearly the entire tailings area during the operational phase and standby periods; therefore, it

will maintain a very low level of radon-222 emissions. The drainage system can be used to accelerate dewatering of the tailings when the impoundment is full.

Effectiveness and Cost

A model single-cell impoundment was used to estimate radon-222 emissions and the effectiveness of single-cell tailings impoundments. The basic design and layout of this impoundment are consistent with previous uranium mill tailings studies. The impoundment is a square sloping pit containing a 12-meter depth of tailings and having a final tailings surface area of 47 ha (116 acres), as shown in Figure 7-3. A synthetic liner is placed along the sides and bottom. It handles about 2000 tons/day of tailings over a 15-year active period. During operation, 20 percent of the surface area is assumed to be dry beach and the remainder is assumed to be water-covered. Cover material is applied after the impoundment has reached capacity or is not going to be used further and the tailings have dried. Emissions average 0.8 kCi/y during the operational 15-year life and increase after drying begins, as shown in Figure 7-4 and Table 7-5.

Emissions are constant at approximately 4.2 kCi/y after the tailings are dry. If an earth cover is applied after drying, emissions can be reduced (as shown in Figure 7-4 and Table 7-5) to about 0.30 kCi/y with 3 meters of earth (Type B soil, 8 percent moisture as shown in Figure 7-1). Total emissions during the 5-year drying period amount to 12.5 kCi.

The approximate costs for constructing a new single-cell impoundment are shown in Table 7-6 for a below-grade design and a partially above-grade design. The cost of a new impoundment would vary widely, depending mainly on the site-specific topography and the ease of excavation. The total cost for a below grade impoundment is approximately $\$41.3 \times 10^6$, including a final cover cost of about $\$6.0 \times 10^6$ ($\$4.15 \times 10^6$ for earth cover and $\$1.9 \times 10^6$ for gravel cap). The partially above-grade design is identical to the below-grade design except that 6 m (19.6 ft) of tailings are below grade and 6 m (19.6 ft) are above grade and surrounded by an earthen dam. This design is less costly because of the savings resulting from decreased excavation. The cost is about $\$29.7 \times 10^6$. Final closure costs are slightly higher at $\$7.8 \times 10^6$, as riprap is required on the sides of the dam.

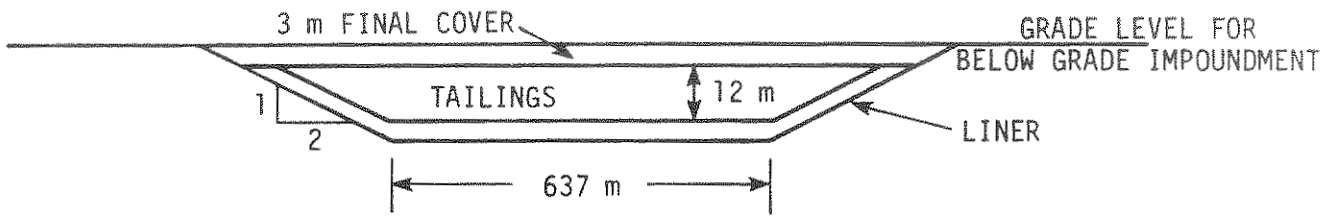

SECTION A-A

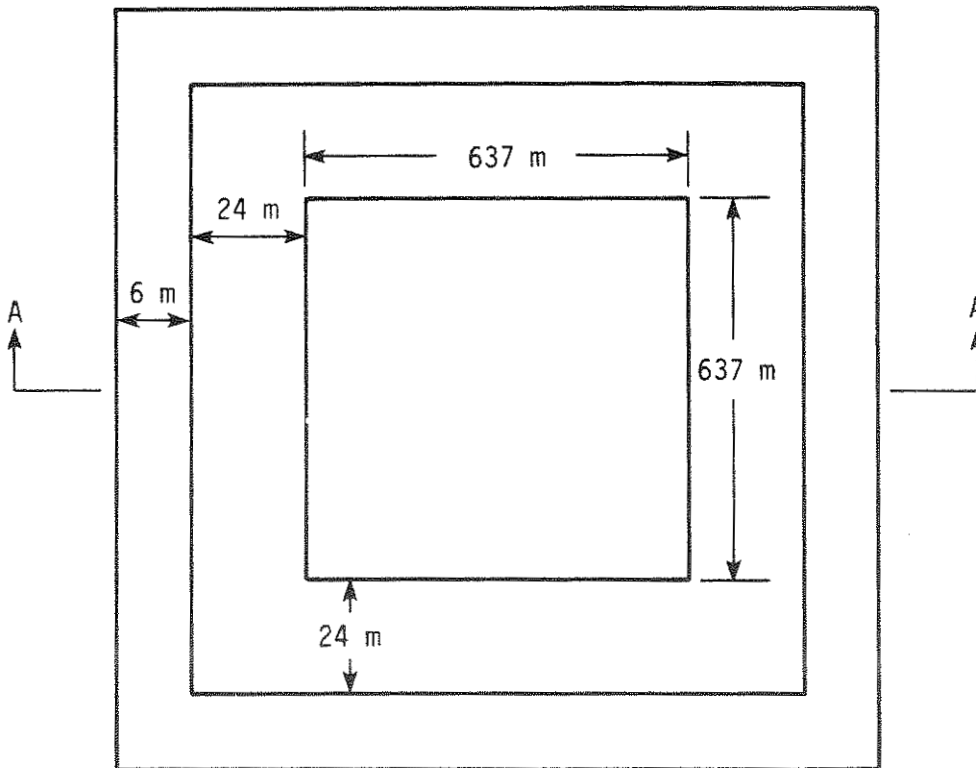

TAILINGS CAPACITY = $1800 \text{ t/d} \times 310 \text{ d/y} \times 15 \text{ y} = 8.4 \times 10^6 \text{ t}$
 TAILINGS VOLUME = $8.4 \times 10^6 \text{ t} \div 1.6 \text{ t/m}^3 = 5.25 \times 10^6 \text{ m}^3$
 FINAL TAILINGS SURFACE AREA = 47 ha (116 acres)
 DIAGRAMS ARE NOT TO SCALE.

Figure 7-3. Size and layout of the model single-cell tailings impoundment.

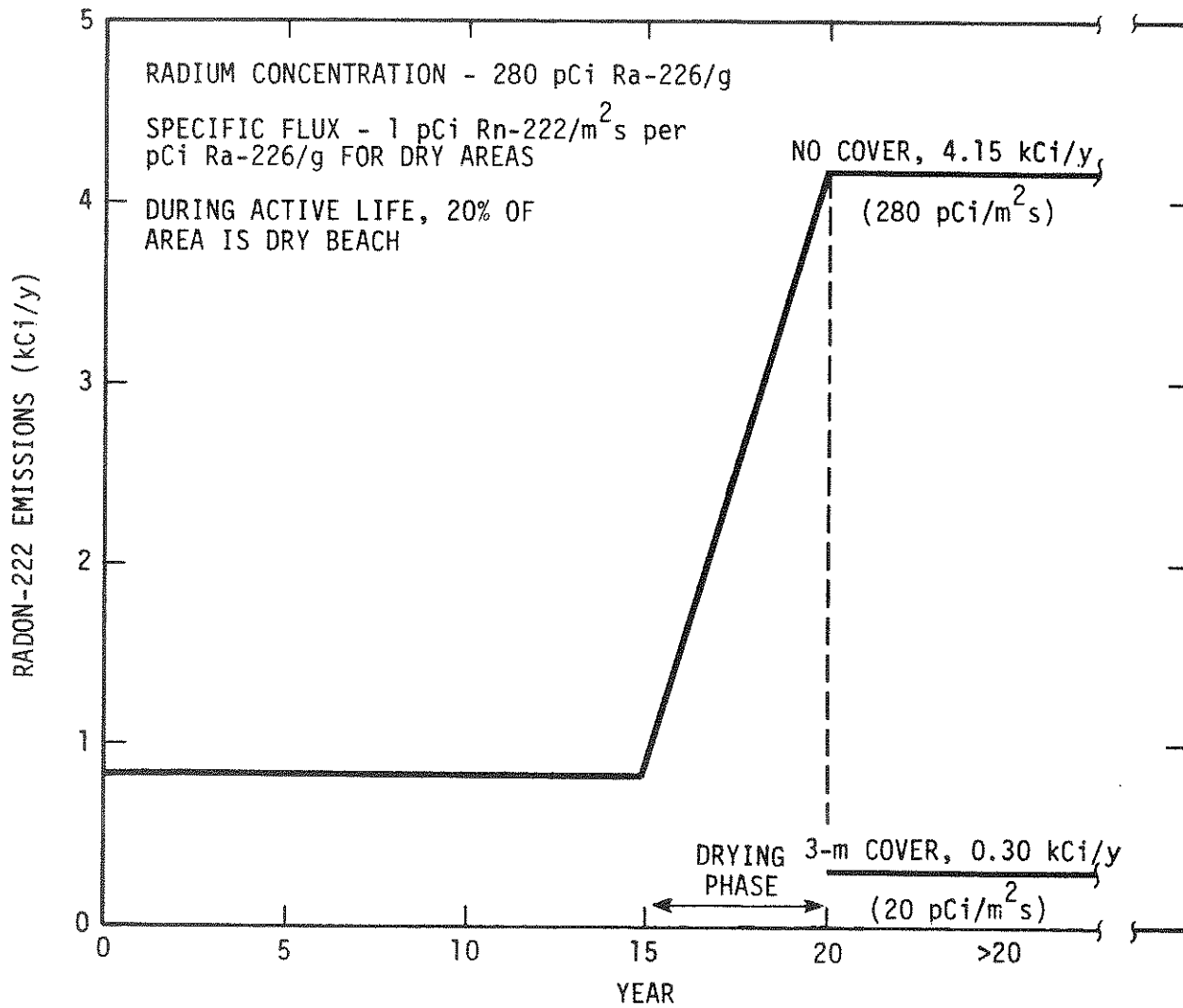

Figure 7-4. Estimated radon-222 emissions from a model single-cell tailings impoundment.

Table 7-5. Average radon-222 emission rate from model single-cell tailings impoundments^(a)

Time period	Emissions (kCi/y)
Year 0-15	0.8
Year 15-20	2.5
Year >20	4.2 uncovered
	0.3 with 3 meters of earth

(a) For 47-ha new model impoundment with 15-year life and 5-year drying-out period. Emissions are based on 280 pCi Ra-226/g and a specific flux of 1 pCi Rn-222/m²s per pCi Ra-226/g of tailings when dry.

Table 7-6. Estimated costs for a model single-cell tailings impoundment^(a)

Item	Costs (\$ x 10 ⁶)	
	Below grade	Partially above grade ^(b)
Excavation	21.51	8.14
Synthetic liner (30-mil)	3.03	3.03
Grading	0.40	0.40
Drainage system	0.40	0.40
Dam construction	-	2.75
Cover (3-m)	4.05	4.05
Gravel cap (0.5-m)	1.92	1.99
Riprap on slopes	-	1.74
Subtotal direct cost	31.31	22.50
Indirect cost ^(c)	10.02	7.21
Total cost	41.33	29.71

- (a) Below-grade impoundments are constructed so that the top of the final cover is at grade.
- (b) Fifty percent below grade and 50 percent above grade.
- (c) Indirect costs are estimated to be 32 percent of direct costs.

7.3.2 Phased-Disposal Tailings Impoundment

In phased-disposal systems, a tailings area is partitioned into sections or cells that are used independently of other sections. After a cell has been filled, it can be dewatered, dried, and covered while another section is in use. In practice, one or two lined cells would be constructed initially. Tailings are pumped to the first cell until it is filled and then pumped to the second cell while the first cell is dewatered and allowed to dry. After the first cell has dried, it would be covered with earth obtained from the cells excavation. This process continues sequentially. This system reduces emissions at any given time, as a cell can be covered after use without interfering with the operation of subsequent cells. Standby periods do not present as great a problem and construction of new cells can easily be postponed. Less total tailings surface area is thus uncovered at any one time compared with operation of the model single-cell impoundment, which is uncovered until mill closure and the impoundment dries.

Several existing mills have either proposed or implemented phased-disposal systems. At the Plateau Resources Shootaring Canyon Mill in Utah, an earthen dam has been constructed across a valley. Behind this dam, earthen beams have been constructed to form six cells for tailings disposal. Currently, only one cell contains a significant quantity of tailings. Umetco's White Mesa Mill, also in Utah, uses a phased tailings disposal system designed to feature simultaneous construction, operation, and reclamation. Three cells of a proposed six-cell system have been constructed. These impoundments are lined with either clay or synthetic liners. Minerals Exploration's Sweetwater Mill also has a planned phased-disposal system. One cell of a proposed multicell impoundment system has been constructed. This system has gone through several iterations during development. Originally, it was designed to consist of four square, below-grade cells.

Effectiveness and Cost

Phased disposal is effective in reducing radon-222 emissions because tailings are assumed to be completely covered with water during cell operation and, finally, with soil. Only during the drying-out period (about 5 years for each cell) do any radon-222 emissions occur, and these are from a relatively small area. During mill standby periods, a water cover could be maintained on the operational cell. For extended standby periods, the cell could be dewatered and an earth or synthetic cover applied. To estimate radon-222 emissions, a model phased-disposal impoundment comparable to the model single-cell impoundment was used. This

impoundment consists of six cells, and each cell holds one-sixth of the mill tailings generated during a 15-year operational period (i.e., 2 years worth of tailings). Each cell is square with a tailings depth of 12 meters and a trapezoidal cross section, as shown in Figure 7-5. The total tailings surface area at capacity is 86,260 m² per cell.

Emissions from a cell during operation are zero because the cell is covered with water. After the first cell reaches capacity, it is dewatered and begins a 5-year drying period. Over this period, radon-222 emissions gradually increase up to a rate of about 0.8 kCi/y, at which time the cell is dry and soil cover is applied. Meanwhile, the second cell has begun drying and also contributing emissions. Emissions thus increase at 2.5-year intervals as the cells reach capacity and begin their drying out periods. The emission rates occurring after 3 meters of earth cover have been applied to dry cells are shown in Figure 7-6. Earth cover of the first cell is not started until after 7.5 years have elapsed. After the final 5-year drying period for the last cell is complete (at the 20th year), this cell is also covered and emissions are then constant at 0.33 kCi/y.

Total emissions during the 20-year operating life of this impoundment are 13.5 kCi. Average radon-222 emission rates are shown in Table 7-7. During the operational phase, the average emission rate of 0.7 kCi/y is lower than that for a single cell impoundment (1.2 kCi/y). In the post-operational period, emissions from a phased-disposal impoundment are much lower than those from uncovered single-cell impoundments and equivalent to those from single-cell impoundments with the same respective earth cover.

Estimated costs of building phased-disposal impoundments are shown in Table 7-8. The total cost of below-grade phased disposal, at \$47.88 x 10⁶, is greater than the cost of a single-cell impoundment with similar earth cover, but the costs are incurred over a 20-y period. This cost is based on a 12-m tailings depth (similar to the model single-cell impoundment). An evaporation pond is included as part of the phased-disposal system. The cost for a partially above-grade phased-disposal system is about \$6.9 x 10⁶ per cell, or a total of \$41.5 x 10⁶. The decreased cost of excavation is partially offset by the dam construction cost and the riprap on the sides.

Numerous variations in the model phased-disposal impoundment are conceivable. An impoundment could be designed to include any number of cells, each capable of containing an equal amount of the mill tailings generated during a 15-year operational period. As an example, a below-grade, phased-disposal impoundment utilizing three cells was investigated.

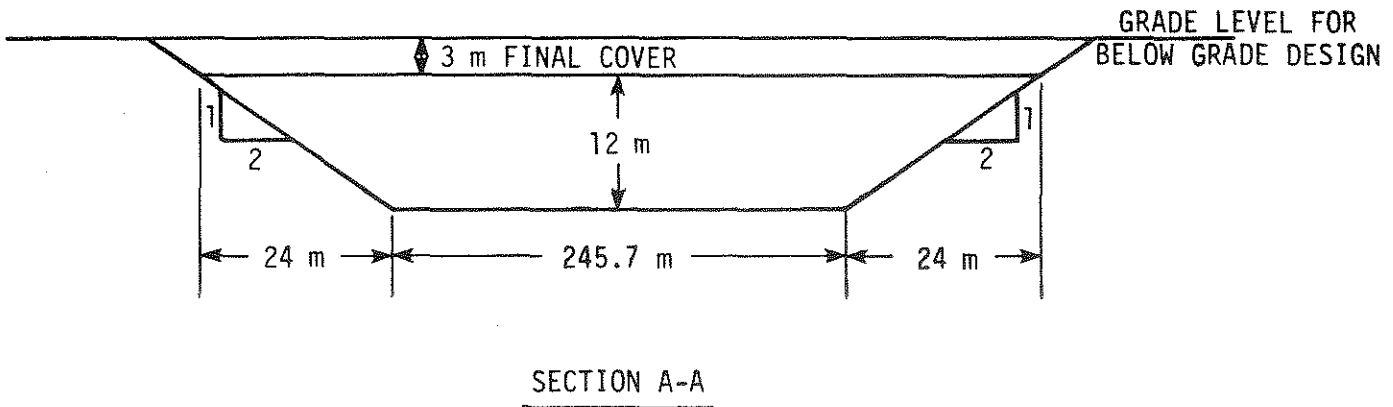
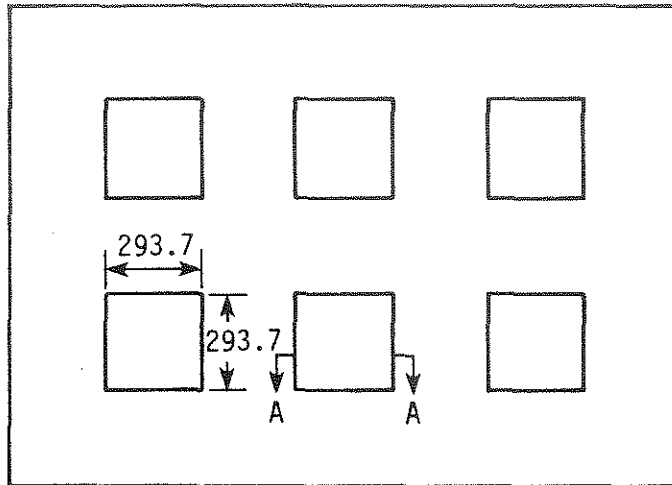

NOTES:

TAILINGS CAPACITY PER CELL = $1800 \text{ t/d} \times 310\text{d/y} \times 15\text{y} \div 6 \text{ CELLS} = 1.4 \times 10^6 \text{ t/CELL}$

TAILINGS VOLUME PER CELL = $1.4 \times 10^6 \text{ t/CELL} \div 1.6 \text{ t/m}^3 = 8.75 \times 10^5 \text{ m}^3/\text{CELL}$

FINAL TAILINGS SURFACE AREA = 8.6 ha/CELL (21.3 acre/CELL)

DIAGRAM IS NOT TO SCALE

Figure 7-5. Size and layout of model phased-disposal impoundment.

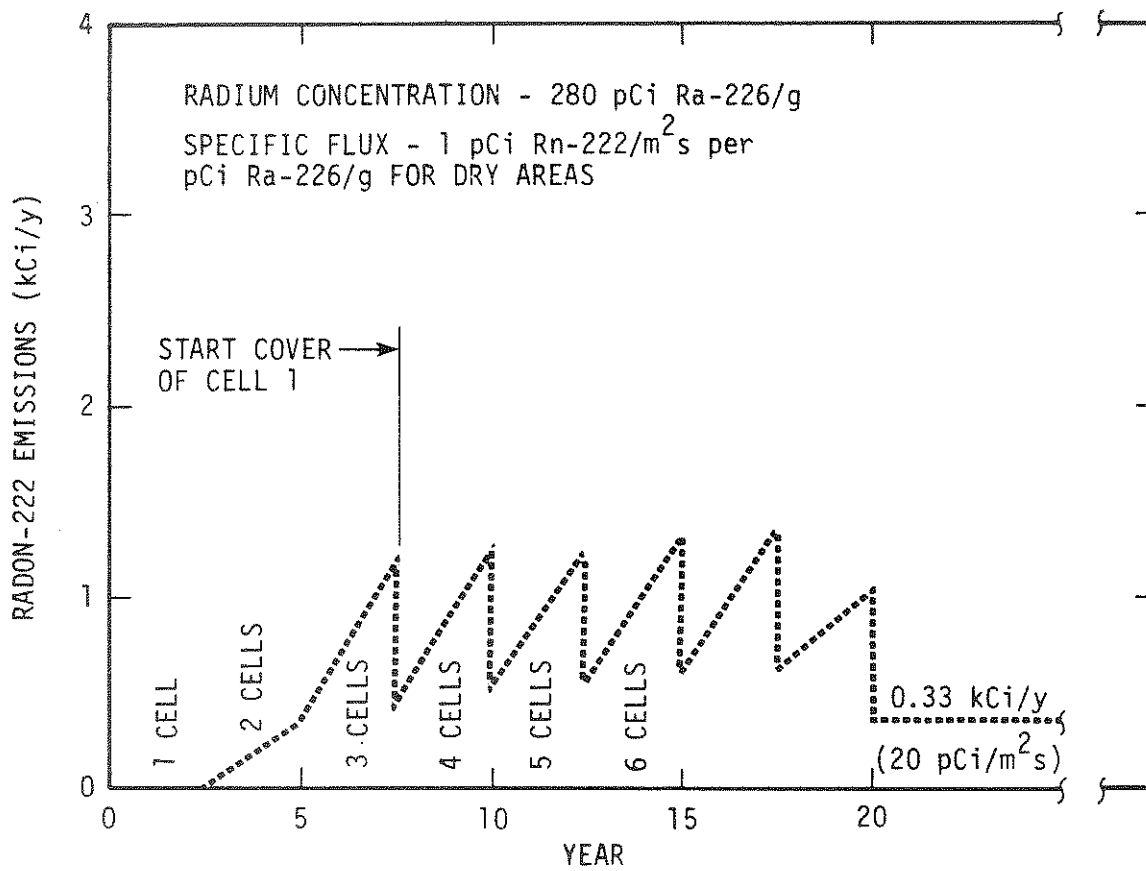

Figure 7-6. Estimated radon-222 emissions from a model phased-disposal impoundment.

Table 7-7. Average radon-222 emission rate for model single-cell and phased-disposal tailings impoundments

	Average emission rate (kCi/y) ^(a)	
	Operational phase ^(b)	Post-operational phase
Single-cell	1.2	4.2 Uncovered 0.30 covered with 3 m of earth
Phased-disposal	0.7	0.33 covered with 3 m of earth

(a) For new model impoundment with 15 yr. life and 5 yr. drying period for each cell. Emissions based on 280 pCi Ra-226/g and specific flux of 1 pCi Rn-222/m²s per pCi Ra-226/g of tailings when dry.

(b) Assumes a 5-y drying-out period for each cell and immediate cover of 3m of earth.

Table 7-8. Estimated costs for a model phased disposal impoundment^(a)
 (\$ x 10⁶)

Item	Below grade		Partially above grade	
	One cell	All cells	One cell	All cells
Excavation	3.68	22.08	1.28	7.70
Synthetic liner (30-mil)	0.57	3.40	0.57	3.40
Grading	0.07	0.45	0.07	0.45
Drainage system	0.07	0.40	0.07	0.40
Dam construction	-	-	1.27	7.61
Cover (3 m)	0.76	4.57	0.76	4.57
Riprap on slopes (0.5 m)	-	-	0.32	1.91
Gravel cap (0.5-m)	0.37	2.21	0.39	2.34
Evaporation pond	0.52	3.09	0.52	3.09
Subtotal direct cost	6.04	36.20	5.25	31.47
Indirect cost ^(b)	1.93	11.58	1.68	10.07
Total cost	7.97	47.78	6.93	41.54

(a) Below-grade impoundments are constructed so that the top of the final cover is at grade. Partially above-grade impoundment is 6 m below grade and 6 m above grade.

(b) Indirect costs are estimated to be 32 percent of direct costs.

Compared with the design of the previously-discussed phased-disposal impoundment with six cells, the three-cell impoundment is conceptually identical except that each cell's capacity is now doubled. Because the total surface area of a three-cell impoundment is somewhat less than that of a six-cell impoundment, some reductions in cost and emissions are effected. The estimated cost of a below-grade, phased-disposal impoundment with three cells is $\$46.58 \times 10^6$, compared with $\$47.88 \times 10^6$ for six cells. The average radon-222 emission rate during the operational phase of a three-cell impoundment is 0.62 kCi/y, compared with 0.67 kCi/y for six cells, and during the post-operational phase, the emissions are 0.31 and 0.33 kCi/y, respectively.

7.3.3 Continuous Disposal

Water can be removed from the tailings slurry prior to disposal. The relatively dry, dewatered (25 to 30% moisture) tailings can be placed and covered with soil almost immediately. No extended drying phase is necessary. Ground-water problems would also be reduced. Implementation of a dewatering system would require added planning, design, and modification of current designs. Acid-based leaching processes do not generally recycle water, and larger evaporation ponds with ancillary piping and pumping systems would be required to handle the liquid removed from the tailings.

Tailings dewatering systems have been used successfully at nonferrous ore beneficiation mills in the United States and Canada (Ro78). Various filtering systems, such as rotary, vacuum, and belt filters, are available and could be adapted to a uranium tailings dewatering system. Experimental studies would be required for a specific ore to determine the filter media and dewatering properties of the sand and slime fractions. The typical mill ore grinding circuit may have to be modified to permit efficient dewatering and to prevent filter plugging or binding. Corrosion-resistant materials would be required in any tailings dewatering system because of the highly-corrosive solutions that must be handled. Although it is used in some foreign countries, continuous tailings dewatering is not practiced at any uranium mills in the United States; however, it has been proposed for several sites. In a planned installation in the Eastern United States, tailings were to be dewatered by a belt filter system and trucked to a tailings disposal area, where a 0.3-m (1-ft) clay cap would be applied (Ma83). An active working edge of 100 m (300 ft) was allowed for spreading, but no more than 4.0 ha (10 acres) of tailings were to be exposed at any one time. The clay cap was to be covered with 0.2 m (8 inches) of gravel and about 2.7 m (8 ft) of random fill. Additional random fill and overburden from a surface mining operation were to complete the tailings cover.

At least three uranium mills have proposed the use of continuous disposal systems. Anaconda submitted conceptual plans of such a tailings disposal system prior to the downturn of the uranium market. However, the plans were never implemented. The system was to be a trench and fill type operation. Tailings were to be thickened to 60 percent solids prior to pumping to 91-m (300-ft) by 2300-m (7500-ft) trenches excavated to a depth of 15 to 21 m (50 to 70 ft). The tailings were then to be covered with 5 m (16 ft) of earthen material. Pioneer Uranium, Inc., submitted plans to build the San Miguel Mill using continuous tailings disposal at Slick Rock, Colorado (NRC81). The mill has not been constructed. The planned tailings disposal operation consisted of below-grade burial of belt-filtered tailings in a series of 10 trenches. Excess water was to be transferred to two evaporation ponds. Each trench would measure 76 by 760 m (250 by 2500 ft) and be 9 to 11 m (30 to 35 ft) below grade. Tailings would be transferred from the mill to the trench via conveyor. Six to 6.4 m (20 to 21 ft) of earth cover would be placed over the tailings. Excavation, filling, and covering would be carried out simultaneously. Umetco Minerals proposed a continuous disposal system that would be located on a mesa adjacent to the Uranium, Colorado, mill. The existing impoundments at this site have been filled to capacity.

Effectiveness and Cost

Continuous disposal is an effective means of reducing radon-222 emissions, especially during the operational life of a uranium mill. Dewatered tailings are placed in trenches and covered with soil shortly after placement, which eliminates the drying period associated with other tailings disposal techniques. The model continuous-disposal impoundment consists of a series of 10 trenches, each having the capacity for one-tenth of the volume of tailings generated over the 15-y life of the model mill. Each trench has sloping sides and contains a 12-m depth of tailings. A 6-m berm separates the trenches to allow for tailings placement. A diagram of the model continuous-disposal impoundment is shown in Figure 7-5. The total tailings surface area at capacity is 572,000 m², or 57,200 m² per trench.

Another alternative method of continuous disposal of uranium mill tailings entails a combination of two previously discussed methods. Continuous/single-cell disposal involves placement of dewatered tailings in a single large impoundment as opposed to placement in a series of trenches. The size of the impoundment would be comparable to that required for the single-cell impoundment. A partially below-grade continuous/single-cell disposal impoundment is also considered because it minimizes the excavation cost as well as the cost of dam construction.

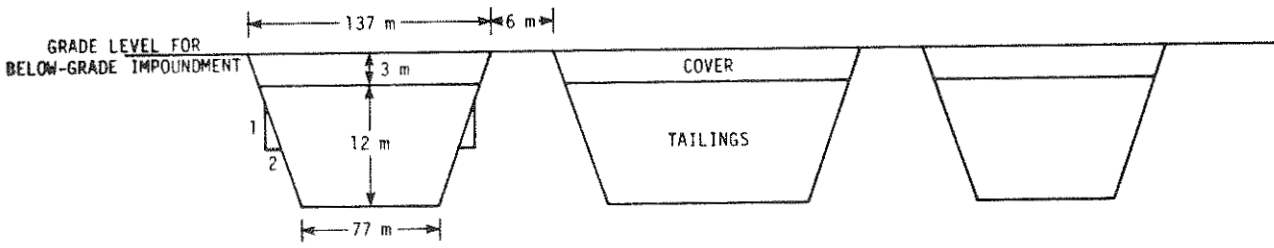
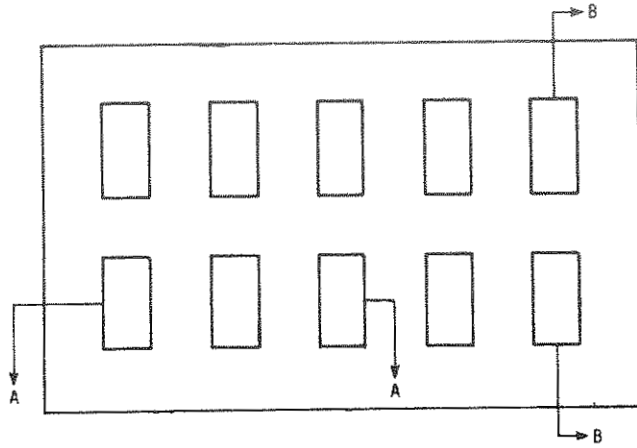

SECTION A-A

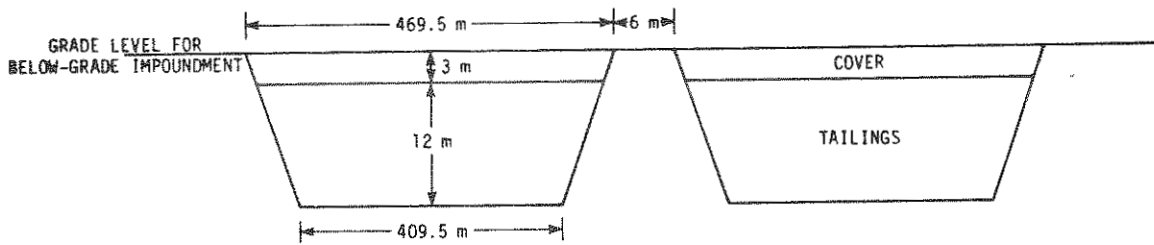

SECTION B-B

NOTES:

TAILINGS CAPACITY PER TRENCH = $1800 \text{ t/d} \times 310 \text{ d/y} \times 15\text{y} \div 10 \text{ TRENCHES} = 8.4 \times 10^5 \text{ t}$

TAILINGS VOLUME PER TRENCH = $8.4 \times 10^5 \text{ t} \div 1.6 \text{ t/m}^3 = 5.25 \times 10^5 \text{ m}^3$

FINAL TAILINGS SURFACE AREA = 5.72 ha/TRENCH (14.1 acre/TRENCH)

DIAGRAM IS NOT TO SCALE

Figure 7-7. Size and layout of the model continuous-disposal impoundment.

Emissions from continuous-disposal impoundments during operation are low. Elimination of the drying-out period, which is responsible for the majority of the operational radon-222 emissions associated with the other model disposal impoundments, substantially reduces emissions from continuous-disposal impoundments. This is evident in Table 7-9, which shows the average emission rates for continuous-disposal and the single-cell model impoundments.

Figures 7-8 and 7-9 show the radon-222 emission rates for the model continuous-disposal impoundments of single-cell and trench designs, respectively. It has been assumed that 4 ha (10 acres) of dewatered tailings are uncovered at any point in time over the 15-y life because of the normal short interval between placement and covering of tailings. At year 15, when the impoundment is at capacity, the final 4 ha of tailings are covered. The final emission rates, 0.36 kCi/y or 0.30 kCi/y, are similar to the other model impoundments. The estimated costs for continuous disposal, shown in Table 7-10, include an evaporation pond for the liquid removed from the tailings and a vacuum filter system. The cost of a below-grade impoundment is estimated to be about $\$54.2 \times 10^6$, and the cost of a partially above-grade trench design system, at about $\$61.0 \times 10^6$. A design consisting of a single large impoundment partially above grade could reduce the large dam construction cost inherent in building 10 trenches. This alternative would cost about $\$37.4 \times 10^6$.

Table 7-9. Estimated radon-222 emission rates for model single-cell, phased disposal, and continuous-disposal tailings impoundments

	<u>Average emission rate (kCi/y) (a)</u>	
	Operational phase	Post-operational phase
Single cell	1.2 ^(b)	4.2 uncovered 0.30 covered with 3m of earth
Phased disposal	0.7 ^(b)	0.33 covered with 3m of earth
Continuous disposal (single-cell)	0.5	0.30 covered with 3m of earth
Continuous disposal (trenched)	0.5	0.36 covered with 3m of earth

(a) For new model impoundments with 15-y operational life emissions based on 280 pCi Ra-226/g and specific flux of 1 pCi Rn-222/m²s per pCi Ra-226/g of tailings when dry.

(b) Includes 5-y drying-out period.

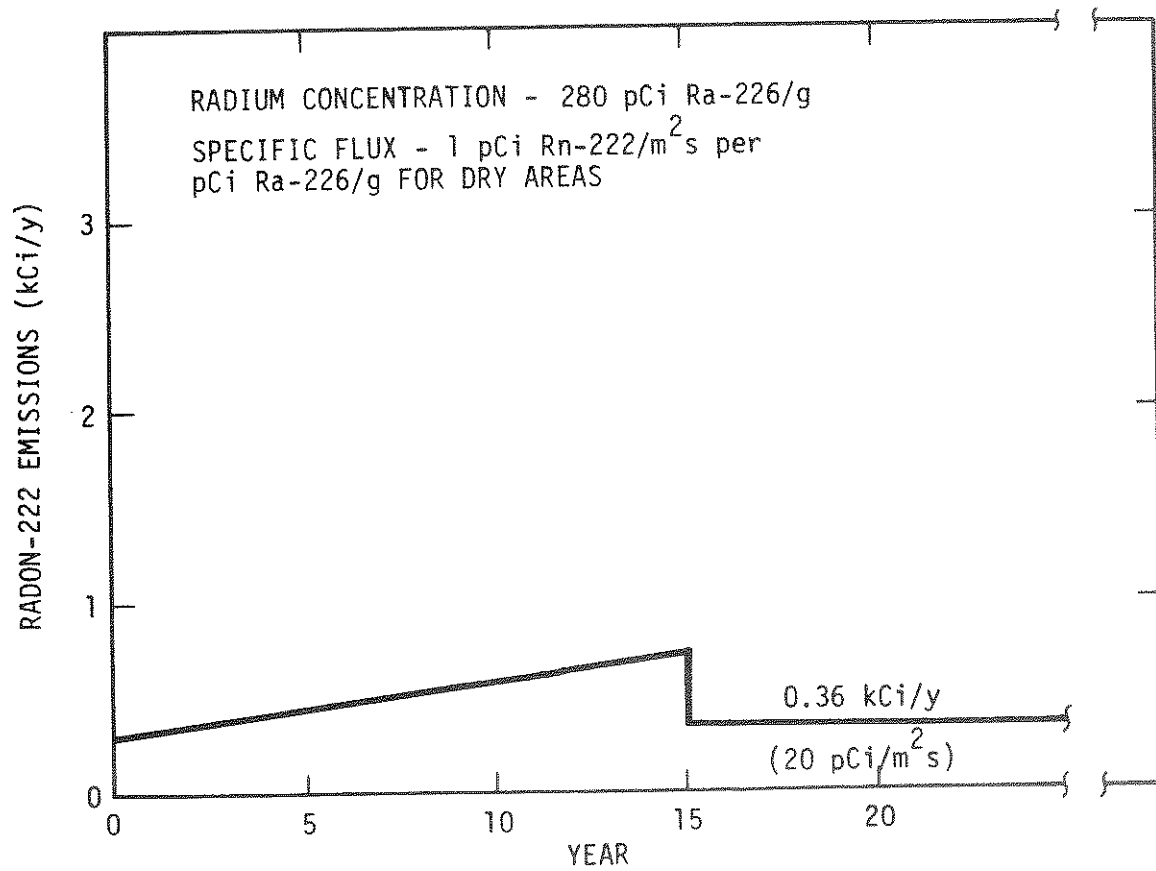

Figure 7-8. Estimated radon-222 emissions from a model continuous-disposal impoundment.

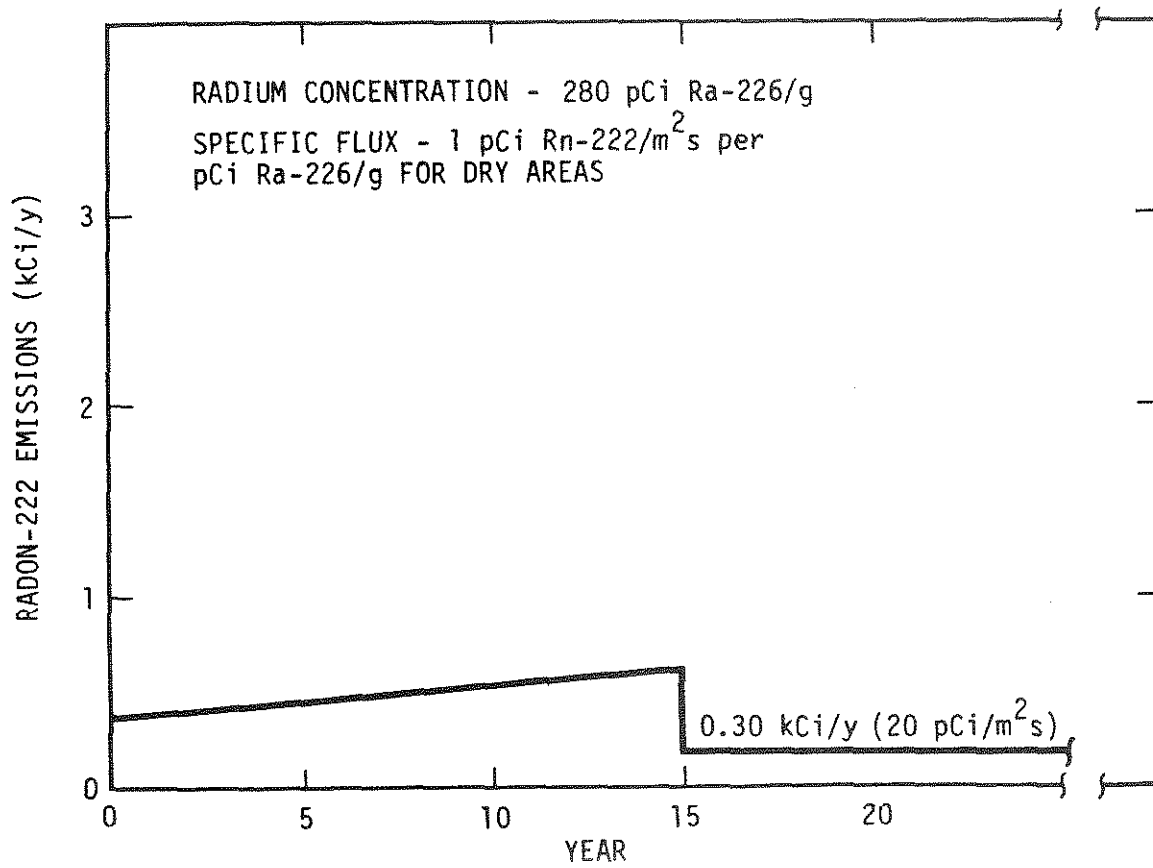

Figure 7-9. Estimated radon-222 emissions from a model continuous/single-cell disposal impoundment.

Table 7-10. Estimated costs for a model continuous disposal impoundment
 (\$ x 10⁶)^(a)

Item	Partially above-grade		
	Below-grade trench design	Single-cell design	Trench design
Excavation ^(b)	22.75	8.14	7.24
Synthetic liner (30-mil)	3.82	3.03	3.82
Grading	0.51	0.40	0.51
Dam construction	-	2.75	18.06
Cover (3-m)	5.15	4.05	5.15
Riprap on slopes	-	1.74	2.15
Gravel cap (0.5-m)	2.54	1.99	2.99
Evaporation pond	4.80	4.80	4.80
Vacuum filter	1.46	1.46	1.46
<hr/>			
Subtotal direct cost	41.03	28.36	36.18
Indirect cost ^(c)	13.13	9.08	11.57
Total cost	54.16	37.44	47.75

(a) In 1985 dollars.

(b) Below-grade impoundments are constructed so that the top of the final cover is at grade. Partially above-grade design is 6 m deep and 6 m above grade.

(c) Indirect costs are estimated to be 32 percent of direct costs.

7.4 Summary of Radon-222 Control Practices

A summary of the radon-222 emissions from new model impoundments serving an 1800 t/day mill is presented in Table 7-9. Three types of emissions are presented: operational, post-operational, and total emissions. The emissions from a model single-cell impoundment represent those with and without final cover to provide a perspective on the emission reductions.

Operational emissions are those that occur during the operating 15 yr. life of the mill plus those due to the impoundment's 5 yr. drying-out period, if applicable. For determination of the average operational emission rates presented, the total amount of emitted radon-222 was calculated and divided by the appropriate 20 or 15 yr. lifetime. Emission rates for the active and drying-out periods of phased- and continuous-disposal impoundments are not presented because these values vary with time. Tailings are being dried at various points in time in a phased-disposal system, and no 5 yr. drying-out period is required for continuous disposal.

Post-operational emissions occur at the end of an impoundment's drying-out period. After the 15-y operational period and the 5-y drying-out period of a single-cell impoundment, radon-222 emissions increase to 4.2 kCi/y with no cover. After compliance with Federal requirements, the emission rate reduces to 0.3 kCi/y. The post-operational emission rates for the model impoundments with final cover meet the Federal emission limit of 20 pCi/m²s. The emission rate for continuous disposal (trench design) with final cover is slightly higher than the others because the tailings surface area is slightly larger.

The final column of Table 7-11 presents cumulative emissions over various time periods. Emissions over these different time periods are the sum of those from the operational phase of an impoundment as well as those occurring after final cover (if applicable). All impoundments with final cover meet an emission limit of 20 pCi/m²s; therefore, variations in emissions from the various covered impoundments are due to different operational emissions and small differences in the tailings surface areas.

Cost estimates for constructing new model tailings impoundments are summarized in Table 7-12. The partially above-grade single-cell impoundment cost, \$29.7 x 10⁶, is the lowest cost alternative, but most of the costs are incurred during initial construction. Its completely below-grade counterpart costs are estimated to be \$41.3 x 10⁶. The difference is largely due to increased excavation costs. Phased and continuous disposal impoundments are more costly, but the costs are spread out over the life of the impoundment.

Table 7-11. Summary of estimated radon-222 emissions from new model tailings impoundments (a)

Alternative	Operational emissions (kCi/y)			Post-operational emissions (kCi/y)		Cumulative emissions total (kCi)		
	Active (15 y)	Dry-out (5 y)	Average	Uncovered	With final cover (b)	20 y	40 y	60 y
1. Single cell (c)	0.8	2.5	1.2 (d)	NA	0.30	25	31	37
2. Phased disposal	NA	NA	0.7 (d)	NA	0.33	13	20	27
3. Continuous disposal (trench) (single-cell)	NA	NA	0.5 (e)	NA	0.36	10	17	24
	NA	NA	0.5 (e)	NA	0.30	9	15	21
4. No action (single cell without cover)	0.8	2.5	1.2 (d)	4.2	NA	25	108	191

NA - Not applicable.

(a) Emission estimates based on a specific flux of 1 pCi/m²s radon-222 per pCi radium-226 per g tailings and a radium-226 concentration of 280 pCi/g.

(b) Final cover to meet 20 pCi/m²s standard.

(c) Assumes 20% of the impoundment area is dry beach during the 15-y active life; remainder of area is water-covered.

(d) Based on 20-y life: 15 y active, and 5 y drying out.

(e) Based on 15-y life.

Table 7-12. Summary of estimated costs for new model tailings impoundment
(1985 \$ x 10⁶)

	<u>Single-cell</u>		<u>Phased-disposal</u>		<u>Continuous-disposal</u>		
	<u>Below grade</u>	<u>Partially above grade</u>	<u>Below grade</u>	<u>Partially above grade</u>	<u>Below grade</u>	<u>Single- cell</u>	<u>Partially above grade Trench</u>
Direct cost	31.3	22.5	36.2	31.5	41.0	28.3	46.2
Indirect cost	10.0	7.2	11.6	10.0	13.1	9.1	14.8
Total cost	41.3	29.7	47.8	41.5	54.1	37.4	61.0

REFERENCES

- Ba84 Baker E. G., Hartley J. N., Freeman H. D., Gates T. E., Nelson D. A, and Dunning R. L., "Asphalt Emulsion Radon Barrier Systems for Uranium Mill Tailings - An Overview of the Technology", DOE/UMT-0214, PNL-4840, March 1984.
- Dr81 Dreesen D. R., Williams J. M., and Cokal E. J., "Thermal Stabilization of Uranium Mill Tailings", in: Proceedings of the Fourth Symposium on Uranium Mill Tailings Management, Fort Collins, Colorado, October 1981.
- EPA83 Environmental Protection Agency, "Final Environmental Impact Statement for Standards for the Control of Byproduct Material from Uranium Ore Processing", EPA 520/1-83-008-1, Office of Radiation Programs, U.S. EPA, Washington, D.C., September 1983.
- Ge84 Gee G. W., Nielson K. K, and Rogers V. C., "Predicting Long-Term Moisture Contents of Earthen Covers at Uranium Mill Tailings Sites", DOE/UMT-0220, PNL-5047, September 1984.
- Ha83 Hartley J. N., Gee G. W., Baker E. G., and Freeman H. D., "1981 Radon-222 Barrier Field Test at Grand Junction Uranium Mill Tailings Pile", DOE/UMT-0213, PNL-4539, April 1983.
- Ha84 Hartley J. N., and Gee G. W., "Uranium Mill Tailings Remedial Action Technology", in: Proceedings of the Second Annual Hazardous Materials Management Conference, Philadelphia, Pennsylvania, June 1984.
- Ha85 Hartley J. N., Glissmeyer J. A., and Hill O. F., "Methods for Estimating Radioactive and Toxic Airborne Source Terms for Uranium Milling Operations", NUREG/CR-4088, Nuclear Regulatory Commission, Washington, D.C., June 1985.
- Ma83 Marline Uranium Corp. and Union Carbide Corp, "An Evaluation of Uranium Development in Pittsylvania County, Virginia", October 15, 1983, Section E.3.
- NRC80 Nuclear Regulatory Commission, "Final Generic Environmental Impact Statement on Uranium Milling", NUREG-0706, September 1980.

- NRC81 Nuclear Regulatory Commission, "Environmental Assessment Related to the Operation of San Miguel Uranium Project", NUREG-0723, January 1981.
- PC79 Portland Cement Assn., "Soil-Cement Construction Handbook", EB003.095, Skokie, Ill. 1979.
- PEI85 PEI Associates, Inc., "Radon-222 Emissions and Control Practices for Licensed Uranium Mills and Their Associated Tailings Piles", EPA Contract No. 68-02-3878, June 1985.
- Ro78 Robinsky E. I., "Tailing Disposal by the Thickened Discharge Method for Improved Economy and Environmental Control", in: Volume 2, Proceedings of the Second International Tailing Symposium, Denver, Colorado, May 1978.
- Ro81 Rogers V. C., and Nielson K. K., "A Handbook for the Determination of Radon-222 Attenuation Through Cover Materials", NUREG/CR-2340, Nuclear Regulatory Commission, Washington, D.C., December 1981.
- Ro84 Rogers V. C., Nielson K. K., and Kalkwarf D. R., Radon "Attenuation Handbook for Uranium Mill Tailings Cover Design", NUREG/CR-3533, 1984.
- St82 Strong K. P. and Levins D. M., "Effect of Moisture Content on Radon Emanation from Uranium Ore and Tailings", Health Physics, 42, 27-32, January 1982.
- Th81 Thode E. F. and Dreesen D. R., "Technico-Economic Analysis of Uranium Mill Tailings Conditioning Alternatives", in: Proceedings of the Fourth Symposium on Uranium Mill Tailings Management, Fort Collins, Colorado, October 1981.
- Wm81 Williams J. M., Cokal E. J., and Dreesen D. R., "Removal of Radioactivity and Mineral Values from Uranium Mill Tailings", in: Proceedings of the Fourth Symposium on Uranium Mill Tailings Management, Fort Collins, Colorado, October 1981.

Chapter 8: SUMMARY AND COMPARISON OF WORK PRACTICES

A number of alternatives are available to reduce radon-222 emissions and subsequent risks from tailings disposal. Both timing and the disposal method effect emissions. The control alternatives, their emissions, costs, and potential benefits are presented in this chapter on a comparable basis by using the model tailings impoundment described in Chapter 7.

8.1 Single-Cell Impoundments

The base case assumes disposal of tailings in a single cell impoundment similar to current practice at many mills. This nominal 50 ha (125 ac) impoundment (actually 47 ha or 116 acres) has a 15 year active life. The surface area is 80 percent wet or ponded during this active period and average radon-222 emissions are 0.8 k Ci/y. Emissions then increase during a 5-year drying period to 4.2 kCi/y. Emissions after this time depend on when the impoundment is covered to comply with Federal and/or state regulations. For illustrative purposes time periods of 0, 20, and 40 years are used before final cover is applied. The total cost for constructing and eventually covering a single cell impoundment is the same, but since the final cover is applied at different times in this example, the net present value of this cost is different.^(a) The longer the cover cost is postponed, the smaller the net present value. A summary of radon-222 emissions and costs for single cell impoundments are presented in Table 8-1.

In Base Case I the impoundment is dry and uncovered for 40 years. This example case yields the highest emissions and least cost since nothing is done for 40 years after the impoundment is full and dry (60 years from start). In Base Case II no cover is applied for 20 years after the impoundment is full and dry (40 years from start). Initially emissions are the same as the first example, but greatly reduced during the 40- to 60-year period since final earth cover is applied. Costs are increased by \$700,000 since the cover cost is incurred 20 years sooner. Covering the impoundment as soon as possible after it is full reduces radon-222 emissions still further and increases the net present value cost by about \$2,500,000 when compared with Base Case I.

(a) Net present value = current cost x $[1/(1 + 0.05)^n]$ at a 5 percent discount rate and where n = years in which cost is incurred.

Table 8-1. Emission and cost comparison for single cell impoundment with final cover applied at 0, 20, and 40 years after reaching capacity

Work practice	Cumulative radon-222 emissions (kCi)				NPV ^(a) costs (\$10 ⁶)
	0-20 y	20-40 y	40-60 y	0-60 y	
Cover 40 years after full - Base Case I	25	83	83	191	33.9
Cover 20 years after full - Base Case II	25	83	6	114	34.6
Cover when full	25	6	6	37	36.4

(a) At 5 percent discount rate.

The risks incurred by leaving a model impoundment uncovered can be estimated from the radon-222 emission rate and assuming the model impoundment has an impact in proportion to that of the current licensed mills as shown below:

$$\text{Risks from model impoundment} = \frac{\text{nationwide risks}}{\text{total emissions}} \times \text{emissions from model impoundment}$$

Based on the current estimated emission rate of 138 kCi/y from licensed mill impoundments and a nationwide fatal cancer rate of 2.34 committed fatal cancers per year (based on 760 deaths per million person WLM), deaths at other emission rates can be estimated.

For the single cell model impoundments deaths and benefits (deaths avoided) were estimated for a 60-year period as shown in Table 8-2. Benefits are determined by comparing with the Base Case I, i.e., not covering for 40 years. When compared with the cover in 20 years case, the benefits of covering immediately when full are reduced to 1.3 deaths avoided over a 60-year period.

8.2 Phased Disposal

Phased disposal provides a means of reducing emissions since the smaller areas involved in each cell at any given time are easier to keep flooded during operation and standby periods. Also, during the drying phase less tailings are exposed. Two model phased disposal impoundments with the same capacity as the large single cell impoundment were characterized to estimate emissions, cost, and potential benefits. A 6-cell, 20-acre-per-cell, and a 3-cell, 40-acre-per-cell impoundment were used as models. Average emissions during a 20-year operational period are 0.7 and 0.6 kCi/y for the 20 acre and 40-acre cell size, respectively. Average radon-222 emissions after being completely covered with earth are similar at 0.33 and 0.31 kCi/y for the 20-acre and 40-acre cells, respectively. The total costs of a 6-cell, 20-acre-per-cell design and a 3-cell, 40 acre cell design are similar but the net present value for the 40-acre-per-cell design is less since some costs are postponed compared with the 20-acre-per-cell design.

The emissions and cost data for below grade phased disposal model impoundments are summarized in Table 8-3. Radon-222 emissions are very similar and the NPV for the 40-acre/cell impoundment is about \$1,500,000 less than the 20 acre/cell design.

Committed fatal cancers for the model phased disposal impoundments were also estimated as shown in Table 8-4. Only a very slight difference in estimated deaths is seen, and this would be expected since emissions are very similar.

Table 8-2. Comparison of estimated deaths and benefits for a single cell model impoundment with final cover applied at 0, 20, and 40 years after reaching capacity

Benefits, Work practice	Nationwide deaths, ^(a)	
	0-60 y	0-60 y
Base Case I - Cover 40 years after full	3.5	--
Base Case II - Cover 20 years after full	2.1	1.4
Cover when full	0.7	2.8

(a) Based on 760 deaths per million person WLM.

Table 8-3. Emissions and costs for model phased disposal impoundments

Work practice	Radon-222 emissions (kCi)				NPV
	0-20 y	20-40 y	40-60 y	0-60 y	costs ^(a) (\$ x 10 ⁶)
6-cell, 20-acre/cell	13	7	7	27	36.1
3-cell, 40-acre/cell	12	6	6	24	34.6

(a) At 5 percent discount rate.

Table 8-4. Comparison of estimated death for model
phased-disposal impoundments

Work practices	Nationwide deaths, ^(a) 0-60 y
20 acre - 6 cell design	0.5
40 acre - 3 cell design	0.4

(a) Based on 760 deaths per million person WLM.

8.3 Continuous Disposal

Dewatering and continuously covering tailings is an attractive but untried method for tailings disposal in this country. By exposing only a relatively small beach area, radon-222 emissions are reduced during operation and a long drying period is not required prior to final cover. A model continuous disposal below-grade, trench type impoundment with the same capacity as the single cell conventional impoundment was used to estimate emissions and cost. Average emissions during the operational period are 0.5 kCi/y and drop to 0.36 kCi/y after the final beach area is covered at the 15-year point. As shown in Table 8-5, cumulative emissions over a 60-year period are 24 kCi. Based on this emission rate, committed fatal cancers from this work practice at a model impoundment amount to 0.4 over a 60-year period. Assuming that costs are incurred at the beginning of each of three 5-year periods, the net present value cost for a below-grade trench impoundment is about $\$43 \times 10^6$.

8.4 Comparison of Work Practices

Work practices for new model tailings impoundments are summarized in Table 8-6 in order to compare their radon-222 emissions, net present value cost, and the resulting health effects attributed to each model impoundment. The single-cell impoundment with cover applied when dry has the highest emissions during its operating life and thus, the highest cumulative emissions. This higher emission rate results in a higher health risk. Phased disposal yields lower emissions during the operating period and thus lower cumulative emissions. Costs are similar to the single-cell impoundment and cumulative health effects are lower. Continuous-disposal emissions are very similar to phased disposal and health effects are thus also similar. Net present value costs for this trench type of disposal are $\$43 \times 10^6$; higher than single-cell or phased-disposal alternatives.

Table 8-5. Emissions and cost of model below-grade trench type
continuous disposal impoundment

<u>Cumulative radon-222 emissions (kCi)</u>				NPV cost ^(a) (\$ x 10 ⁶)
0-20 y	20-40 y	40-60 y	0-60 y	
10	7	7	24	43.3

(a) At 5 percent discount rate.

Table 8-6. Comparison of work practices for new model tailings impoundments

Work practice	Cumulative radon-222 emissions (kCi)				NPV of work practice @ 5% discount ($\$ \times 10^6$)	Committed fatal cancers ^(a) 0-60 y
	0-20 y	20-40 y	40-60 y	0-60 y		
1. Single cell covered when full (20 y from start)	25	6	6	37	36.4	0.6
2. Phased disposal 20-acre cells	13	7	7	27	36.1	0.5
3. Phased disposal 40-acre cells	12	6	6	24	34.6	0.4
4. Continuous dis- posal (trench- type)	10	7	7	24	43.3	0.4

(a) Nationwide, based on 760 deaths/ 10^6 person WLM. Assumes model plant is at average location of existing mills.

When compared with an uncovered single-cell impoundment, all the work practices yield similar benefits in the form of avoided deaths. Costs of these alternative work practices are also similar except for continuous disposal which is about $\$9 \times 10^6$ higher. Tables 8-7 and 8-8 present a comparison between the alternative work practices and a base case single cell impoundment uncovered for 40 years and also 20 years respectively. Depending on the base case selected, benefits of about 1.4 to 2.8 deaths avoided can be realized for a model impoundment over a 60-year period when alternative work practices are used.

Table 8-7. Comparison of cost and benefits between model Base Case I and new work practices

Work practice	Difference in NPV from base case (\$ x 10 ⁶)	Deaths avoided ^(a) 0-60 y
Base Case I Single cell covered 40 y after full (60 y from start)	--	--
1. Single cell covered when full (20 y from start)	2.5	2.8
2. Phased disposal 20-acre cells	2.2	3.0
3. Phased disposal 40-acre cells	0.7	3.1
4. Continuous disposal (trench-type)	9.4	3.1

(a) Nationwide basis.

Table 8-8. Comparison of cost and benefits between model
Base Case II and new work practices

Work practice	Difference in NPV from base case (\$ x 10 ⁶)	Deaths avoided ^(a) 0-60 y
Base Case II Single cell covered 20 y after full (40 y from start)	--	--
1. Single cell covered when full (20 y from start)	1.8	1.4
2. Phased disposal 20-acre cells	1.5	1.6
3. Phased disposal 40-acre cells	-	1.7
4. Continuous disposal (trench-type)	8.7	1.7

(a) Nationwide basis.

APPENDIX A
DIAGRAMS OF URANIUM MILL SITES AND
TAILINGS IMPOUNDMENTS

Diagrams of each of the 20 licensed uranium mill sites that were included in this evaluation are presented in this appendix. These diagrams were adapted from aerial photographs taken by the Office of Radiation Programs. The diagrams are presented to show the relative location of the tailings impoundments, mill structures, and other important site features. Approximate scales and the dates of the aerial photograph are indicated on each diagram.

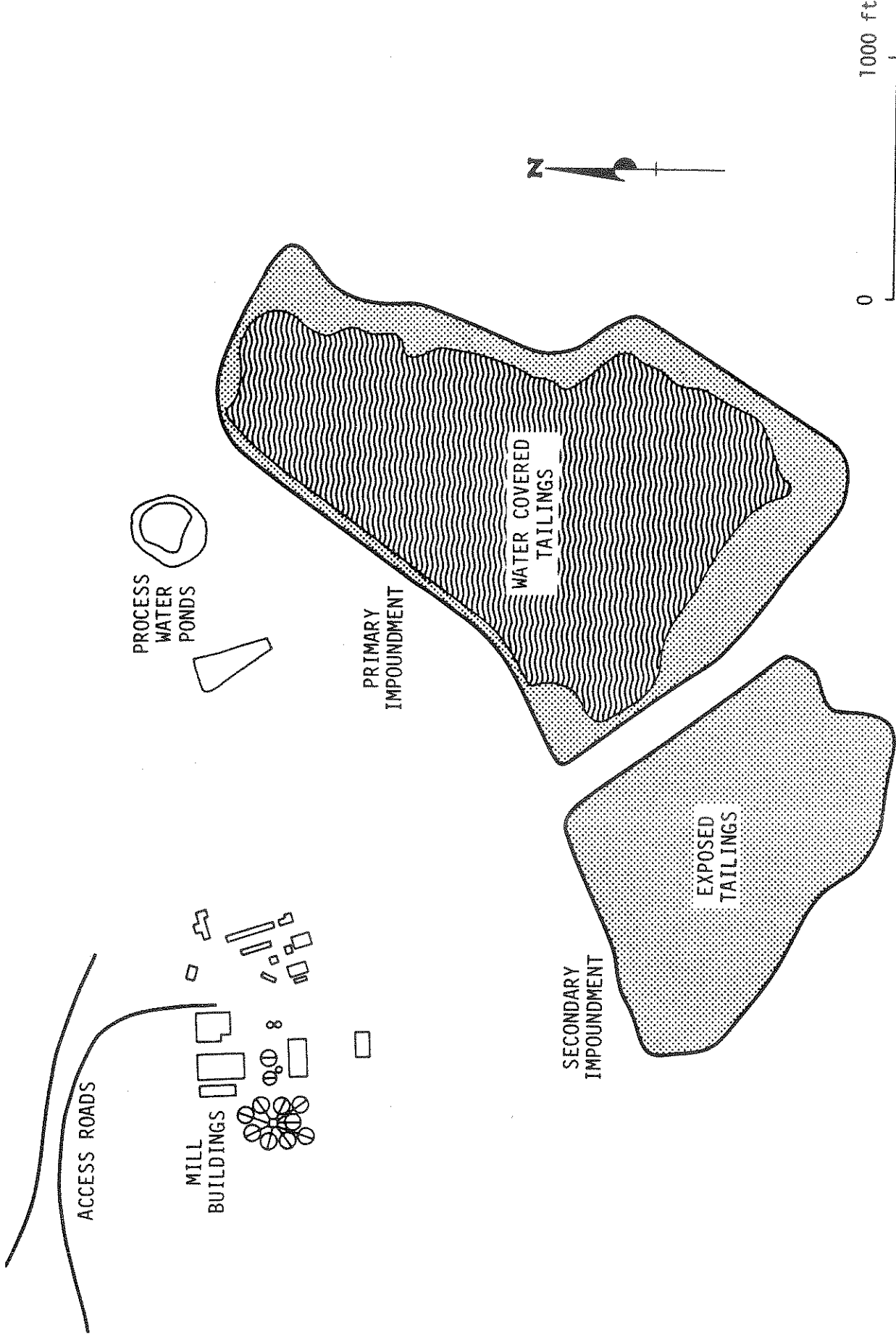

COTTER CORP. MILL
 CANON CITY, CO
 DATE: 8/12/85

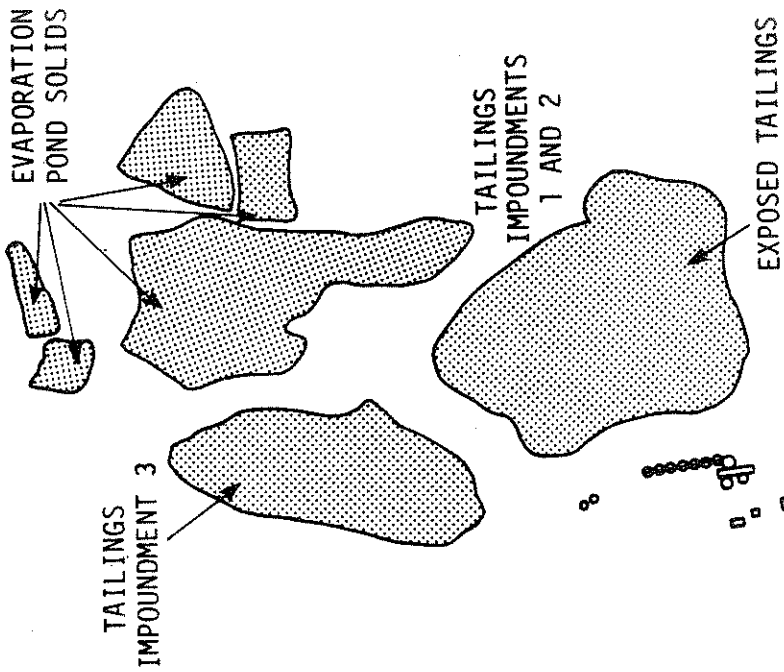

0 1000 ft

UMETCO MINERALS MILL
URAVAN, CO.
DATE: 8/7/85

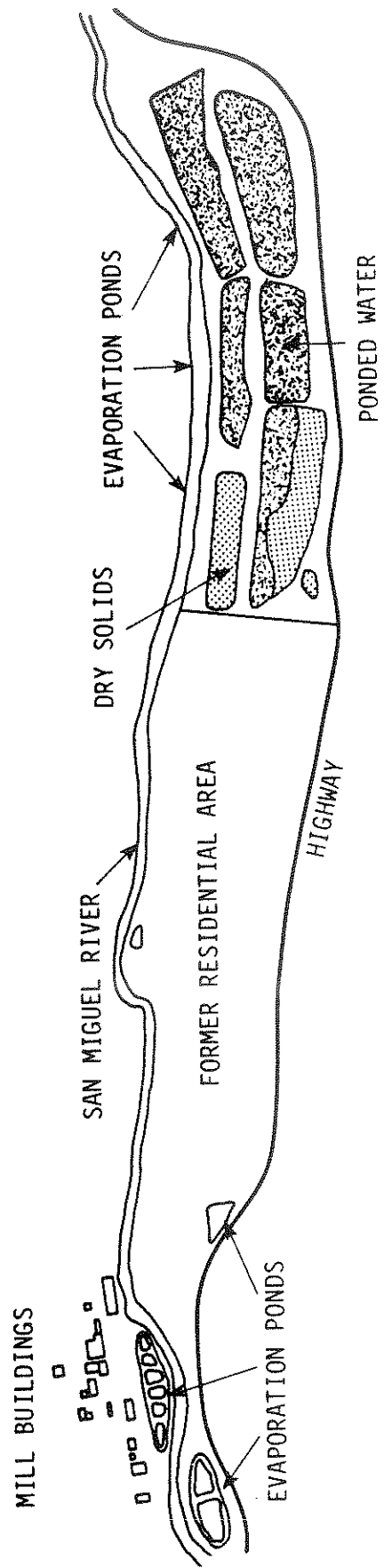
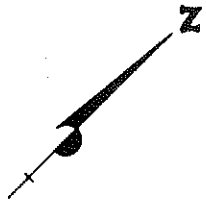

A-5

SOHIO MILL
CEBOLLETA, NM
DATE: 10/5/85

0 1000 ft

L-BAR TAILINGS
IMPOUNDMENT

WATER COVERED
TAILINGS

EXPOSED TAILINGS

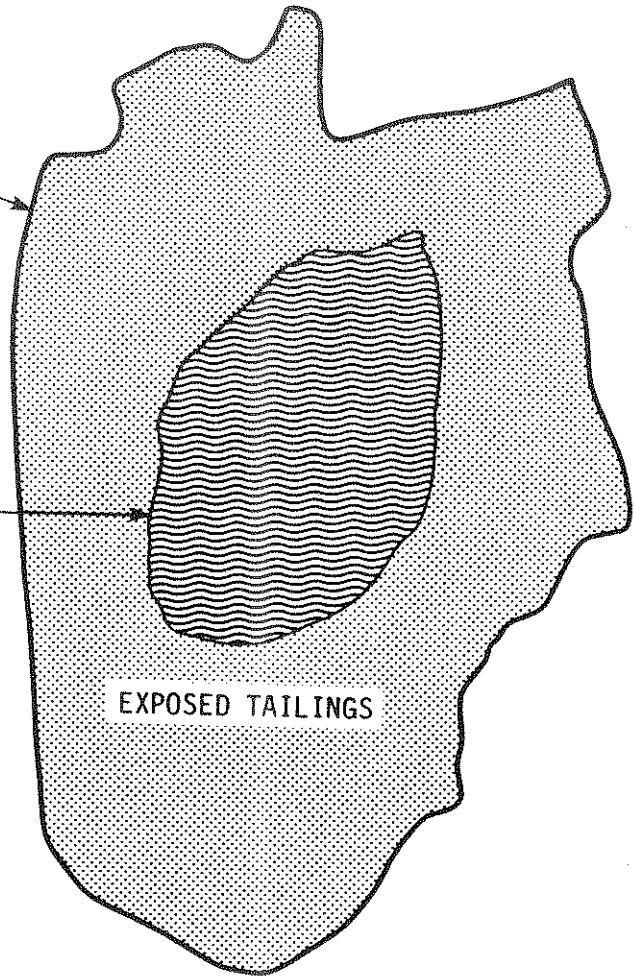

ACCESS ROAD

MILL BUILDINGS

MINEWATER
POND

MINE
BUILDINGS

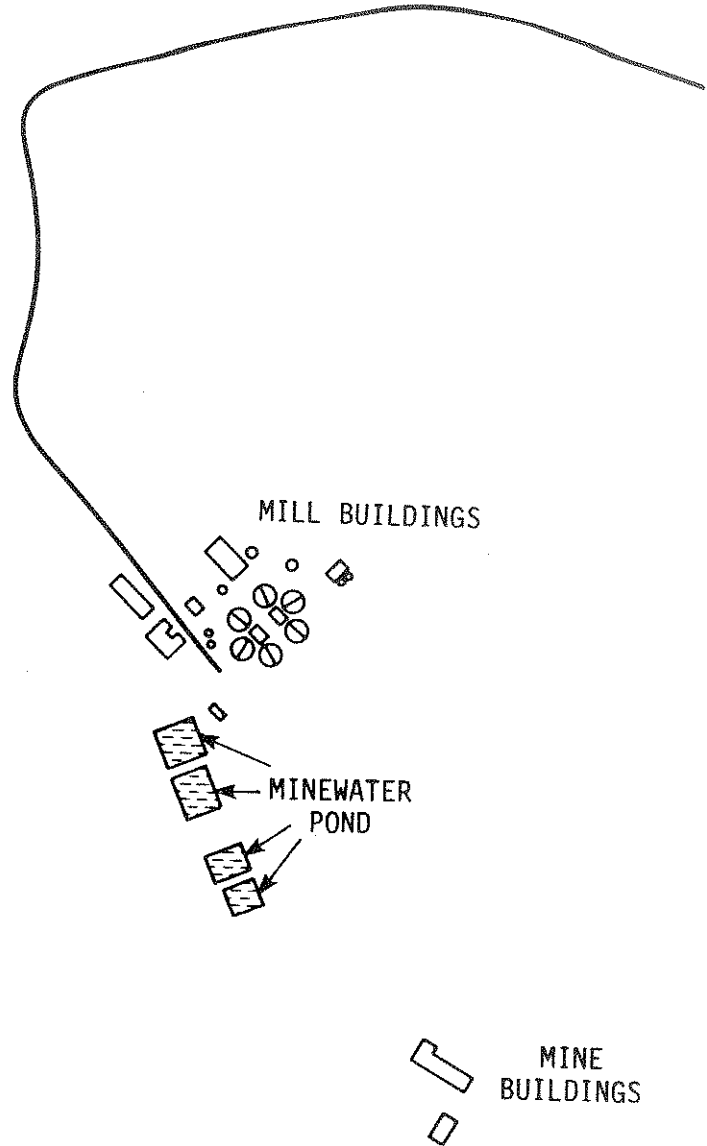

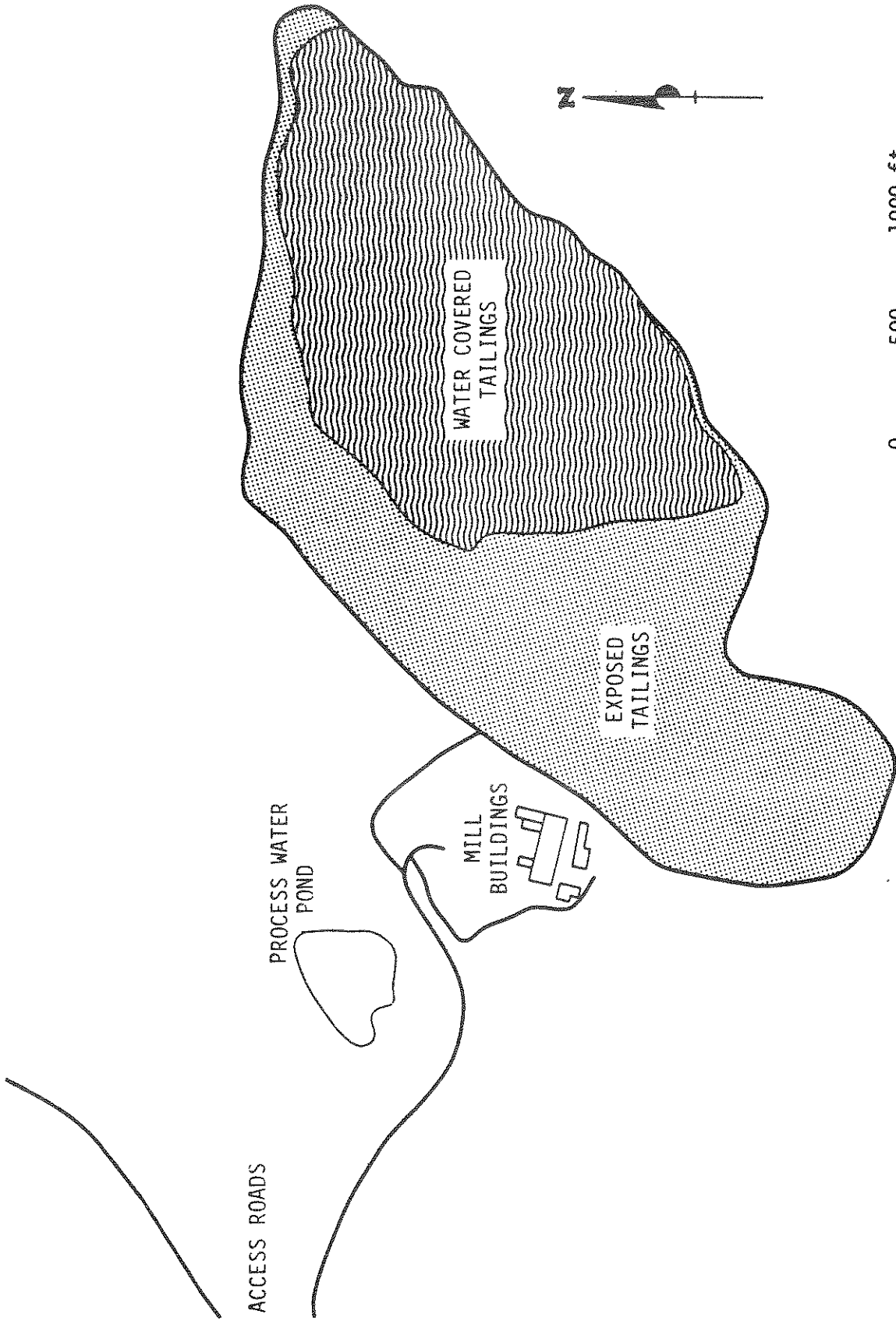

WESTERN NUCLEAR MILL
JEFFREY CITY, WY
DATE: 8/8/85

A-19

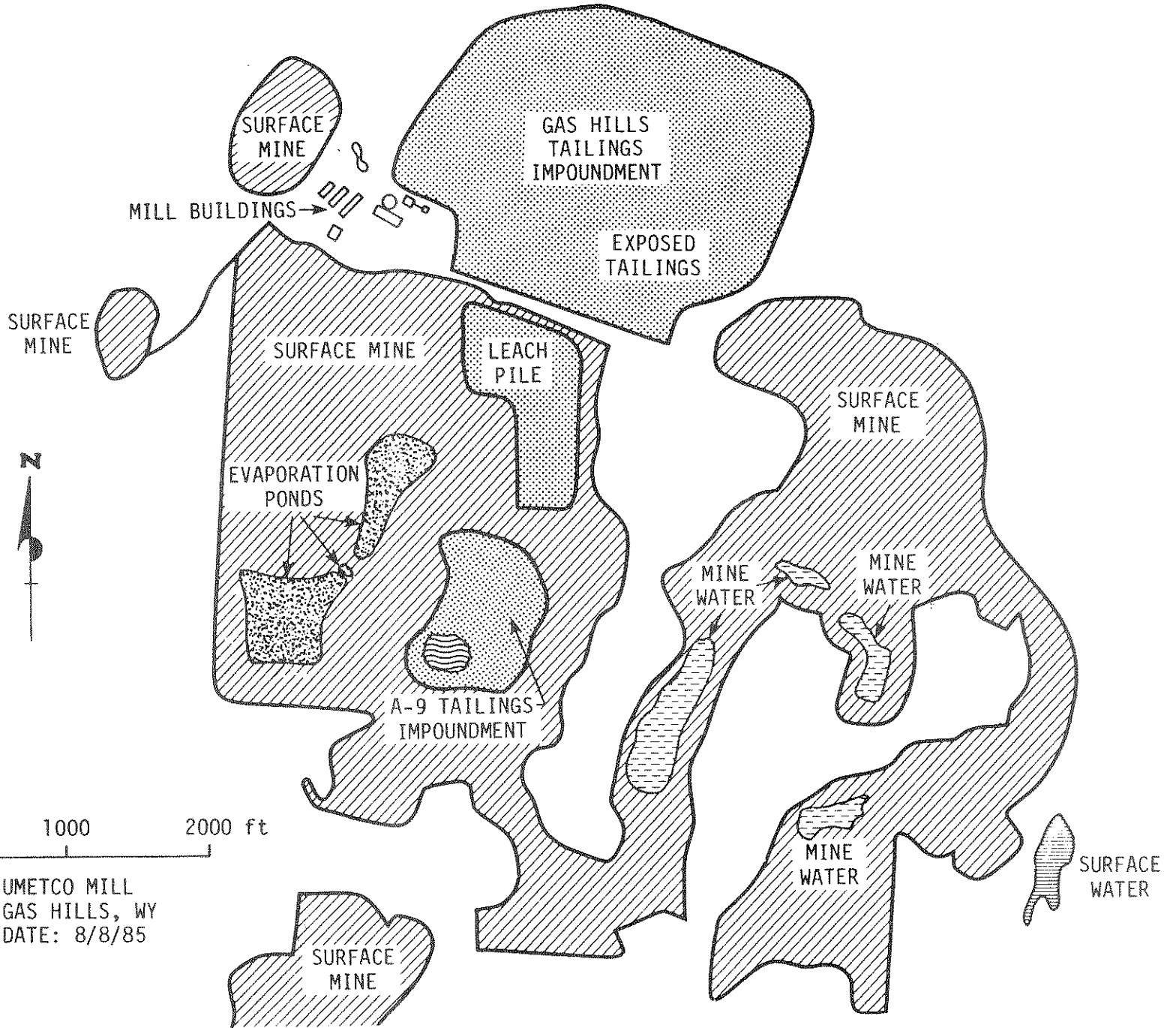

0 1000 2000 ft

UMETCO MILL
GAS HILLS, WY
DATE: 8/8/85

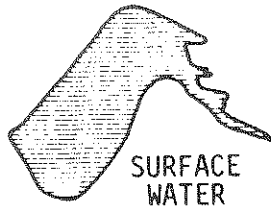

SURFACE WATER

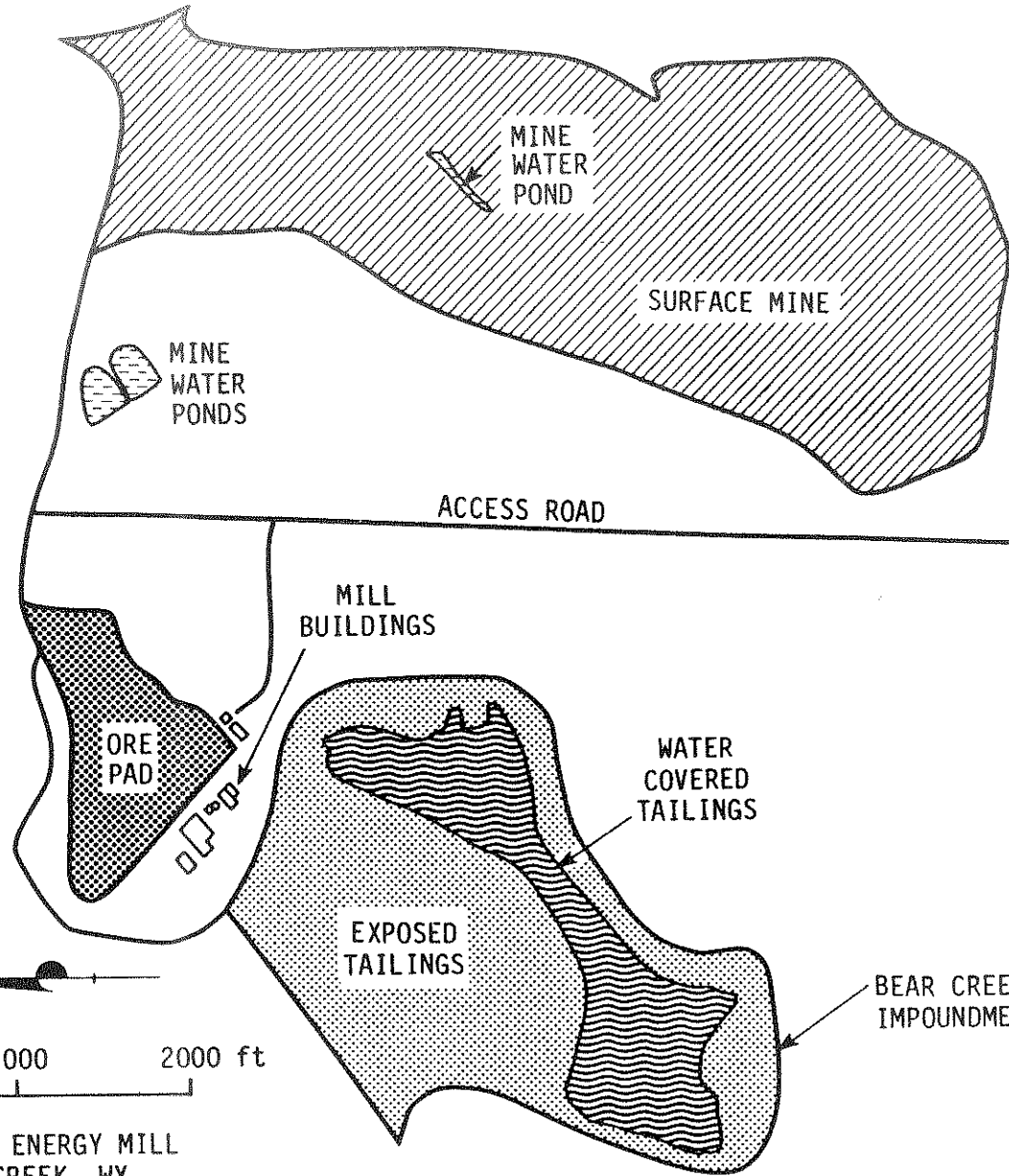

MINE WATER POND

SURFACE MINE

MINE WATER PONDS

ACCESS ROAD

MILL BUILDINGS

ORE PAD

WATER COVERED TAILINGS

EXPOSED TAILINGS

BEAR CREEK TAILINGS IMPOUNDMENT



0 1000 2000 ft

ROCKY MT. ENERGY MILL
BEAR CREEK, WY
DATE: 9/13/85

SHIRLEY BASIN
TAILINGS IMPOUNDMENT

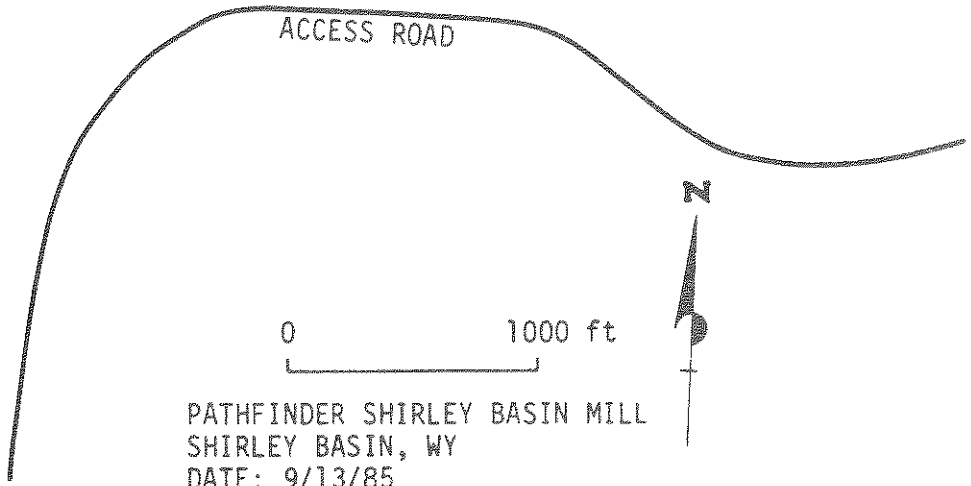
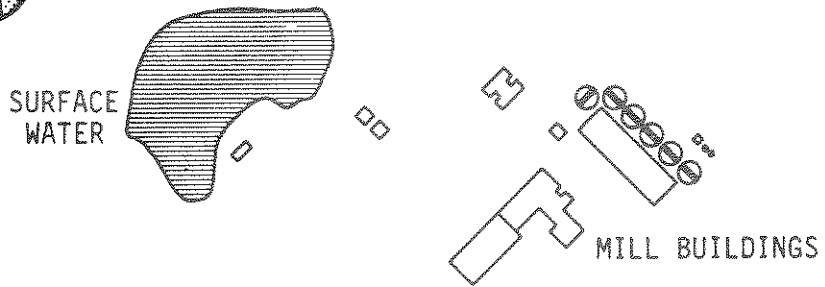
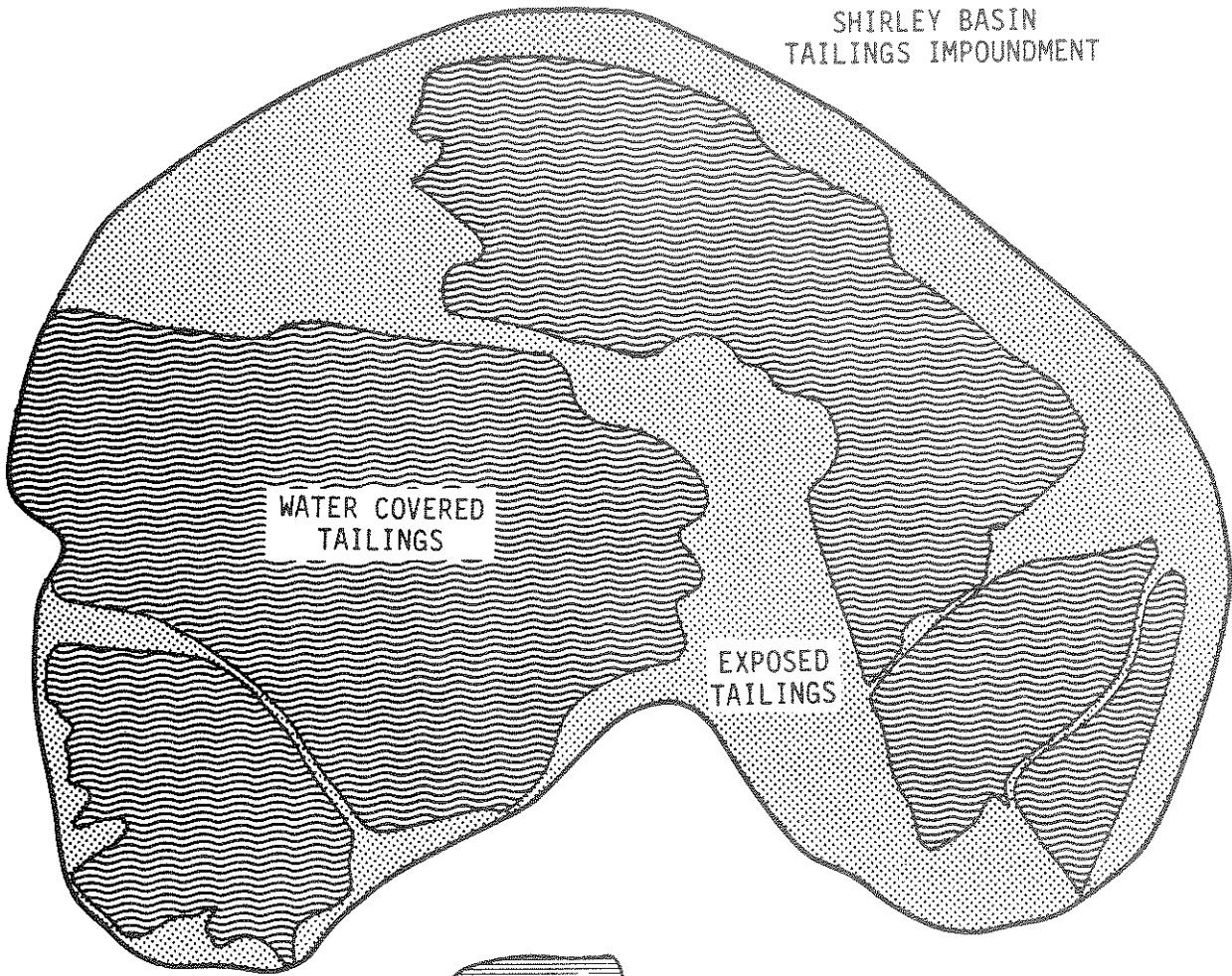

PATHFINDER SHIRLEY BASIN MILL
SHIRLEY BASIN, WY
DATE: 9/13/85

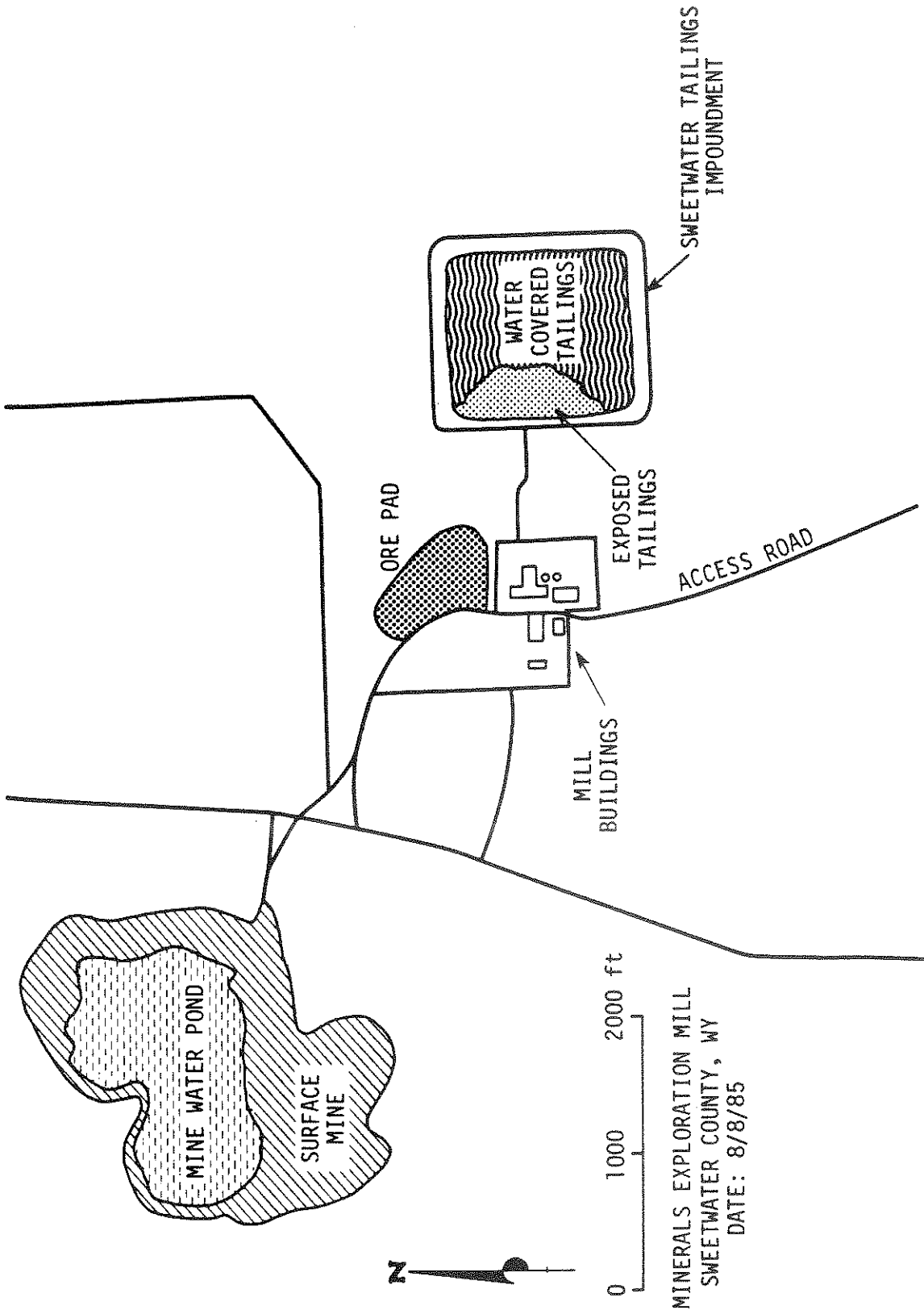

MINERALS EXPLORATION MILL
 SWEETWATER COUNTY, WY
 DATE: 8/8/85

APPENDIX B

COST ESTIMATES FOR EXISTING AND MODEL
NEW URANIUM MILL TAILINGS IMPOUNDMENTS

Appendix B: COST ESTIMATES FOR EXISTING AND MODEL NEW URANIUM MILL TAILINGS IMPOUNDMENTS

This Appendix presents the approach, assumptions, and bases used to generate the cost estimates of Chapter 7. For existing impoundments, the most recent available site-specific information was used to estimate the cost of interim control and final reclamation measures. For new tailings impoundments, model impoundments were designed, which formed the basis of the cost estimate.

All costs are presented in 1985 dollars, which have not been discounted. Both direct and indirect costs are included. In general, direct costs represent labor, equipment, and material costs. A total of 32 percent was added to this figure to cover indirect cost items such as engineering, insurance, contingency, etc. Table B-1 presents information on the indirect cost factors used in preparation of the cost estimates.

B.1 Existing Impoundments

Detailed data on each existing site were obtained from various sources (DOE82, EPA85, NRC84, PEI85). Two types of work practice control measures were considered for control of radon-222 from existing uranium mill tailings impoundments: interim control and final reclamation.

Interim Control

Interim control involved placing 1 meter of earth on the surface of all dry tailings areas of an impoundment. For sand tailings dams, the amount of soil required to cover the embankment slopes was also included. Interim control is considered a temporary measure; therefore, neither the costs of reclamation of the source of cover soil (borrow pits) nor the costs of impoundment erosion control were included. A unit cost of \$4.35/yd³ (\$7.00/m³) was used to estimate the cost of placing the interim cover. This includes the direct costs of excavation, hauling, spreading, and compacting the cover.

Final Reclamation

Measures for effecting final reclamation of existing uranium mill tailings impoundments are those required to reduce the radon-222 flux to 20 pCi/m²s and to place the impoundment in a state of permanent, long-term stability.

Table B-1. Indirect cost factors used in the cost estimation of uranium mill tailings impoundments

Indirect cost item	Percentage	
	Range	Value used
Engineering and design	2.5 - 6.0	5.0
Insurance	0.1 - 0.82	0.5
Performance bond	0.39 - 1.2	0.5
Permits	0.5 - 2.0	1.0
Overhead and profit	10 - 15	10.0
Contingency at conceptual stage	15 - 20	<u>15.0</u>
Total		32.0

Source: "Means Site Work Cost Data 1985," 4th Annual Edition, R.S. Means Co., Inc.

No credits for earth covers that may have previously been placed for interim control measures were considered to be of help in achieving final reclamation. Final reclamation was assumed to be possible immediately after an impoundment had dried. No cost for attaining dry-out was assumed. The measures taken and the costs of final reclamation depend on the type of impoundment and its size.

An estimate of the cost of covering each impoundment with sufficient earth to reduce the radon-222 flux to 20 pCi/m²s was based on the radium-226 concentration of the tailings. Costs of reclaiming a borrow pit (source of the earth for cover) and placing an 18-inch thick gravel cap on top also were included for each impoundment. For impoundments that are constructed of sand tailings dams, the costs for regrading slopes to 5:1(H:V) and protection of the slopes' earthen cover with 18 inches of riprap were also included. For these cost estimates, it was assumed that the slopes of each dam constructed of tailings originally had 1:1 (H:V) slopes. These slopes would be reshaped to 5:1 (H:V) before placement of the cover and riprap. As discussed earlier, indirect costs were then added to the direct costs to obtain the total cost of final reclamation of existing impoundments.

B.2 New Tailings Impoundments

Four types of model impoundments were defined for estimation of the costs of constructing new uranium mill tailings impoundments: single-cell, phased-disposal, continuous-disposal, and continuous/single-cell disposal impoundments. Costs of the first three types of impoundments were estimated for below-grade placement of tailings and for partially below-grade placement. Only partially (50 percent) below-grade placement of tailings was considered for the model continuous/single-cell disposal impoundment.

Each model impoundment was assumed to have 2:1 (H:V) interior sloping sides, to contain a 12-meter depth of tailings, and to have 6 meters of tailings below grade and 6 meters above-grade (in the case of the partially below-grade impoundment). This arrangement ensures the comparability of the cost estimates for the various impoundments. Each model impoundment is designed or sized to handle the production output of the model mill over its 15-year life (NRC80), which is estimated to be 8.4×10^6 t of tailings with a volume of 5.25×10^6 m³.

Single-Cell Impoundments

The single-cell impoundments are large, square impoundments. For the below-grade impoundment, 15 meters of earth is excavated so that the final level of the impoundment, which will contain a 12 meter depth of tailings and be covered with 3 meters of earth, is at grade. For the partially below-grade single-cell impoundment, a depth of 6 meters of tailings is below-grade; therefore, the top of the impoundment after final cover is 9 meters above grade. Each type of impoundment has a 30-mil synthetic liner and a drainage system to facilitate dewatering when the impoundment has reached capacity. For the partially below-grade impoundments, embankments are constructed from the excavated material, which is also used for the final cover. The embankments are 9 meters high, have a 6-meter berm, and have interior and exterior slopes of 2:1 and 5:1, respectively. The exterior of the embankment is covered with riprap for erosion protection. An 18-inch gravel cap is placed atop the final cover of each type of impoundment for protection. The total estimated costs for the below-grade and the partially below grade single-cell impoundments are $\$41.3 \times 10^6$ and $\$29.7 \times 10^6$ (1985 dollars), respectively. The difference is largely due to the additional excavation required for a below-grade impoundment.

Phased Disposal Impoundments

The phased-disposal impoundment consists of a series of small impoundments or cells that are constructed sequentially, filled, and brought to final reclamation over the life of the model mill. The six cells are similar in design to the single-cell impoundment, but the capacity of each is just one-sixth of the total tailings quantity.

Unlike the model single-cell impoundment, an evaporation pond is included in the cost estimate of phased-disposal impoundments. The impoundment surface area available for evaporation is much smaller; therefore, an evaporation pond is required. The estimate includes both the cost of construction and the cost of closure of the evaporation pond at the end of the mill's life.

Excavation to a depth of 6 meters for the partially below-grade phased-disposal impoundment does not provide sufficient earth to construct the dam and to place a 3-meter earth cover over the tailings. Thus, the costs of obtaining

additional earth and reclaiming a borrow pit are included in the cost of the dam construction. The total estimated costs for the below-grade and the partially below-grade phased disposal impoundments are $\$47.8 \times 10^6$ and $\$41.5 \times 10^6$ (1985 dollars), respectively.

Continuous Disposal Impoundments

A series of 10 rectangular trenches are included in the model continuous-disposal impoundments. As in phased disposal, the trenches would be constructed sequentially, filled, and covered over the life of the model mill. Unlike phased disposal, however, the tailings are dewatered to allow for almost immediate placement of the cover. The estimate includes the cost of a vacuum filter to dewater the tailings. An evaporation pond (larger than that required for the phased-disposal model) is also needed. The tailings are dewatered prior to disposal; therefore, no drainage system is necessary.

The volume excavated is insufficient to meet the earth requirements for the partially below-grade continuous-disposal impoundment dam. The shortfall is made up by hauling earth from a borrow pit, which is later reclaimed. These costs are included in that of the dam construction. The total estimated costs for the below-grade and the partially below-grade continuous-disposal impoundments are $\$54.2 \times 10^6$ and $\$61.0 \times 10^6$ (1985 dollars), respectively.

Continuous/Single Cell Disposal Impoundment

The design of the continuous/single-cell disposal impoundment includes a single, partially below-grade impoundment for placement of dewatered tailings, as opposed to a series of trenches. Such a design substantially lowers the estimated cost of the dam construction, as it eliminates individual embankments between trenches and the need to haul in additional earth. The total cost of $\$37.4 \times 10^6$ (1985 dollars) is essentially the same as that estimated for the partially below-grade single-cell impoundment except that an evaporation pond and vacuum filter are still required because the tailings must be dewatered.

REFERENCES

- DOE82 Department of Energy, "Commingled Uranium Tailings Study", DOE/ DP-0011, Office of Defense Waste and Byproducts Management, Washington, D.C., June 30, 1982.
- EPA85 U.S. Environmental Protection Agency, "Draft Document-Estimates of Population Distributions and Tailings Areas Around Licensed Uranium Mill Sites", Office of Radiation Programs, November 1985.
- NRC80 Nuclear Regulatory Commission, "Final Generic Environmental Impact Statement on Uranium Milling", NUREG-0706, September 1980.
- NRC84 Nuclear Regulatory Commission, "Directory and Profile of Licensed Uranium-Recovery Facilities", Office of State Programs, NUREG/CR-2869, Washington, D.C., March 1984.
- PEI85 PEI Associates, Inc., "Radon-222 Emissions and Control Practices for Licensed Uranium Mills and Their Associated Tailings Piles, Final Report", prepared for the U.S. Environmental Protection Agency, Office of Radiation Programs, Document No. PEI 3642-6, June 1985 (revised November 1985).

APPENDIX C
EVALUATION OF INTERIM COVER
AS A CONTROL OPTION

CONTENTS

	<u>Page</u>
1. Introduction	1-1
2. Technical Issues	2-1
2.1 Introduction	2-1
2.2 Effectiveness of Interim Cover	2-2
2.3 Applicability of Interim Cover	2-4
2.4 Timing of Interim Cover	2-7
2.5 Operational Aspects	2-8

Chapter 1: INTRODUCTION

The use of an earthen cover on the dry portion of inactive tailings impoundments can potentially reduce radon-222 emissions by restricting the diffusion of this gas long enough to allow decay. In developing the background information for the proposed standard, the option of using a temporary or interim earthen cover evolved as a possible work practice standard. This cover would be placed on dry portions of impoundments that are not in use. The cover would be about 1 foot or 1 meter in depth (depending on the selected option). If and when the impoundment returned to active use, tailings would be dumped on top of the earth cover. Other methods of reducing radon-222 emissions include water cover, and synthetic or asphalt covers. Maintaining a water cover causes potential ground water and, at some sites, dam stability problems. If a mill is on standby, water cover will be difficult to maintain due to evaporation. Synthetic or asphalt covers have not been evaluated over longer time periods on a large scale and their true effectiveness is not known. Thus, only a limited number of viable options are available for reducing radon-222 emissions from existing tailings impoundments, namely:

Apply a relatively shallow earthen (interim) cover over the dry areas when the impoundments are not in use (i.e., standby).

Discontinue tailings disposal in current impoundments and apply final cover per existing standards.

Various schedules can be used with either of these options as described in the Federal Register Notice of February 21, 1986.

An analysis of these alternatives for reducing radon-222 indicated that the application of an interim earthen cover appeared to be a cost effective option if an impoundment was not used again. This option is therefore being reevaluated to better assess its practicability, effectiveness and cost.

Chapter 2: TECHNICAL ISSUES

2.1 Introduction

Interim earthen covers of 0.3 or 1 m having 8 percent moisture content theoretically reduce radon-222 emissions by about 37 and 62 percent, respectively. The actual effectiveness of such interim covers has never been demonstrated on licensed tailings impoundments. Additionally, while use of earthen covers is a demonstrated control technology at inactive uranium mill tailings sites, it has never been used on a short term basis to limit radon-222 emissions from licensed tailings impoundments on active or standby status. Therefore the evaluation of interim cover is based on best engineering judgment and not practical experience. However, the use of thick (3 m) earth covers to control radon-222 and provide long-term stabilization of inactive tailings piles is demonstrated technology. The evaluation of interim cover, particularly estimation of its effectiveness in controlling radon-222, is based on research conducted under the UMTRCA program.

Several characteristics of the impoundments impact the potential use of interim cover. Site-specific characteristics such as evaporation rates, dam construction, phreatic level, availability of cover material, presence of liners, expected length of standby periods, remaining capacity and expected mill life must be considered on a site by site basis.

Uranium mill tailings are deposited as a slurry in tailings impoundments. Three major types of impoundments currently exist: those where coarse tailings are used as dam construction material (11 impoundments representing 32 percent of total tailings area); those using earthen dams (22 impoundments representing 65 percent of the total area); and below-grade impoundments (5 impoundments representing about 3 percent of the total). As discussed in later sections, impoundment construction affects the applicability of interim cover. Additionally, climate plays an important role in determining how much time is required to allow an impoundment to dry sufficiently before interim cover can be applied. For example, some tailings impoundments are located in arid areas (i.e., New Mexico) relatively wet areas (i.e., Texas, Washington) and areas that experience severe winter weather (i.e., Wyoming). The geology beneath an impoundment also impacts the time required for drying. The geologic settings vary from porous underlayments (sandy soils of New Mexico) to relatively impermeable bases (clay foundations in Texas). For example, impoundments in New Mexico would dry relatively quickly because of seepage through the bottom coupled with high evaporation rates while the Panna Maria

impoundment in Texas would require a longer drying period because of the impermeable base that would inhibit dewatering by seepage and the relatively high rainfall rate. There are also several operational aspects that must be evaluated when considering interim cover. For example, annual maintenance, periodic inspections, enforcement, and loss of capacity must be included in the evaluation. Each of these items are discussed in the following sections.

2.2 Effectiveness of Interim Cover

The effectiveness of any earthen cover depends mainly on its moisture content and depth, and the homogeneity and integrity of the cover layer. The effectiveness of an earth cover was estimated in the Draft BID by using diffusion equations which take into account the cover material and tailings density, porosity, specific gravity and moisture content, and by assuming these properties do not vary throughout the cover or tailings, or with time. These idealized conditions would not typically be achieved in practice and the actual effectiveness would probably be less than the calculated effectiveness. The applicability of the basic diffusion equation to relatively shallow earth covers, such as 0.3 m, is also questionable.

The key variable effecting the effectiveness of an earthen cover of given depth in controlling radon-222 is its moisture content. An example of this variation is shown in Figure 2-1. For a 1-meter depth of cover with 12 percent moisture, about 20 percent of the radon-222 released from the tailings surface would still emanate from the cover. If the cover material dries out to 6 percent, about 47 percent of the radon-222 from the tailings would emanate from the cover. Thus, the emissions increased by a factor of 2.35 ($47/20$) or the effectiveness decreased by about 33 percent. Similar losses in effectiveness are evident for all depths of earth cover. However, a thicker cover will not dry out as completely or quickly as a thin cover, and soils with a higher silt and clay content will retain more moisture much longer than a sandy soil.

In addition to the cover material's moisture content, the overall integrity of the cover must be maintained in order to reduce radon-222 emanations. Wind and rain erode an earth cover, thus reducing its depth and subsequent effectiveness. In addition, cracks from freeze-thaw cycles, subsidence, or burrowing animals decrease a shallow cover's effectiveness. When final reclamation is implemented, gravel, rip-rap, or vegetation cover, and additional grading and runoff control are included to decrease erosion and ensure the long-term integrity of the cover. These items are not included in interim earth covers since, by definition, they are not designed as long-term control techniques.

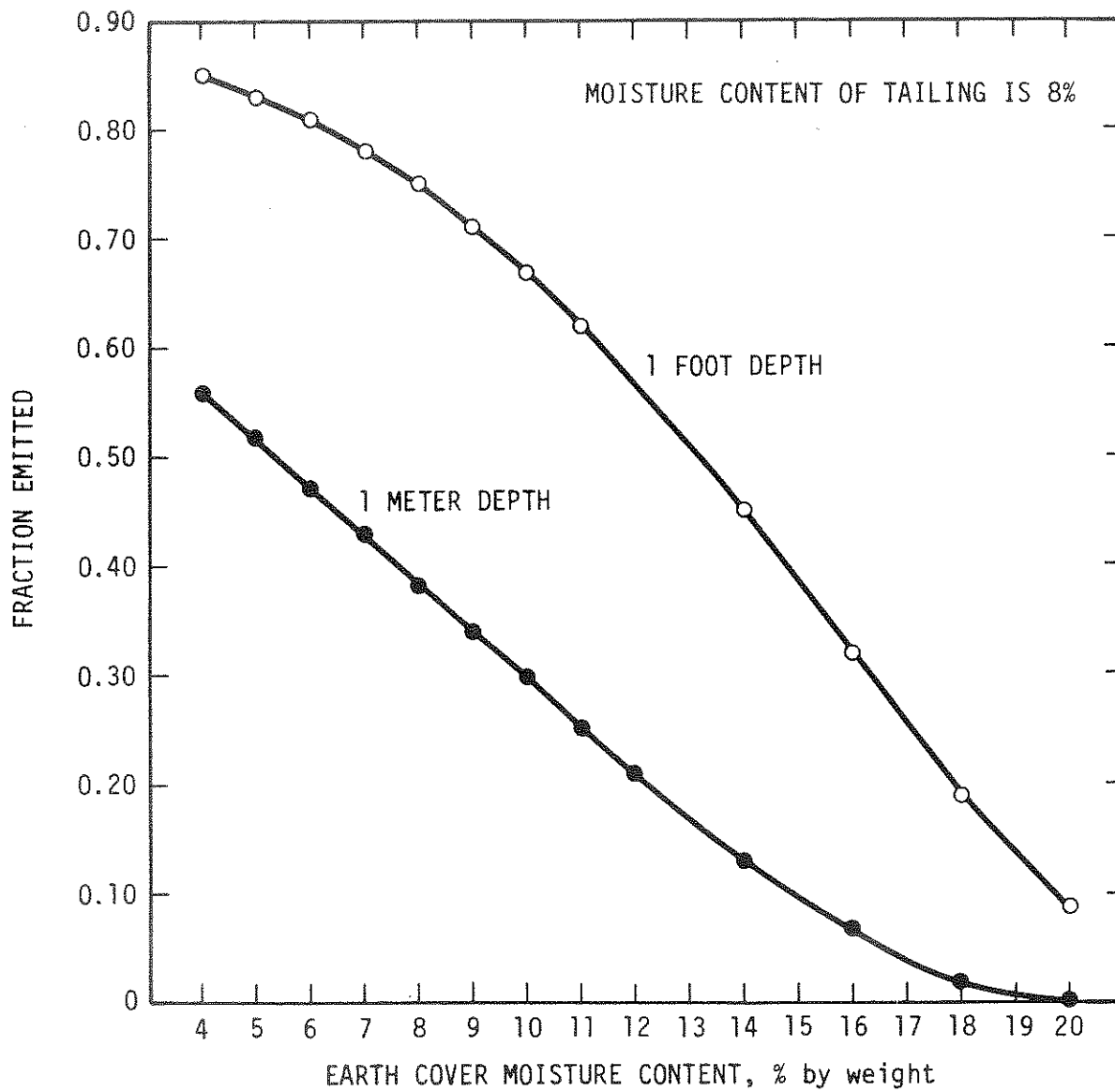

Figure 2-1. Variation in earth cover effectiveness with moisture content.

The combination of surface drying, erosion, and loss of integrity reduces the interim cover's effectiveness. This loss in effectiveness would be especially evident in a shallow cover of only 0.3 m. The exact decrease in effectiveness is not known and cannot be calculated readily since these factors are highly variable and site-specific. The loss in effectiveness can be offset by frequent maintenance of the earth cover, as discussed under Operational Aspects.

2.3 Applicability of Interim Cover

Limitations regarding the placement of interim cover are associated with physical conditions of the tailings. The water content of the tailing and the slope of the surface are controlling factors. Tailings must be dry in order to support earthmoving equipment and the cover itself. Tailings are dewatered and dried by seepage from the impoundment and by evaporation. (The time required to achieve sufficient dryness is discussed in Section 2.4.) The tops of tailings impoundments are essentially flat, and if thoroughly dry, would pose no difficulty to placement of interim cover. However, 11 impoundments at 6 mill sites are constructed with dams made of coarse tailings (Type 1 impoundments). The outer faces of these dams are steep (approximately 2.5:1, H:V). Placement of interim cover on these dams would be difficult because of the steep slope. In addition, seepage through the dams could cause instability and slumping of the interim cover. Conversely, the interim cover could cause the phreatic surface to rise in the dam by inhibiting seepage through the dam. This occurrence could cause a decrease in the stability of the dam itself.

In evaluating the applicability of interim cover, three distinct situations currently exist on tailings impoundments. These conditions and how they affect the applicability of interim cover are addressed below.

Interim Cover on Dams Constructed of Tailings

The faces of these dams are at a slope of about 2.5:1 (H:V), it probably would not be possible to apply and maintain interim cover to these steep areas without recontouring the impoundment. Recontouring would result in a significant loss of storage capacity. Additionally, it would be very difficult to compact cover material placed on such a slope. Uncompacted material would be subject to more rapid wind and water erosion.

These slopes (300 acres, total) represent 8 percent of total area and 15 percent of currently dry areas.

20 percent of this sloped area is at impoundments that have been filled to capacity (Uravan). These impoundments would more logically apply final cover.

12 percent of this sloped area is at impoundments at sites that have indicated decommissioning will begin soon (L-Bar and Churchrock). These impoundments would more logically apply final cover.

31 percent of the total sloped area is at one major impoundment (Homestake), that is a 4 sided structure, with steep slopes (2 to 2.5:1) that would be most difficult to place interim cover on without recontouring.

Coarse tailings are reported to have lower Ra-226 content than the slimes. Therefore, these areas have a lower source term than the tops of the impoundments.

Piezometers and movement benchmarks used to monitor the stability of these dams would have to be extended and their use uninterrupted during application of interim cover.

It would be necessary to provide drainage between the tailings and the earthen cover to allow any seepage through the dam to escape without building up a hydrostatic head that could cause dam failure. Seepage through these dams is inherent to their design and must be maintained. A drainage system, such as a blanket drain, would also provide a permeable path for radon-222 migration, making at least the lower portion of the cover less effective.

Interim Cover on Tops of Unlined Type 1 and Type 2 Impoundments

Tops of Type 1 and 2 unlined impoundments account for 75 percent of the total tailings area.

Current dry areas on top of these piles equal 44 percent of the total and 73 percent of the currently dry areas.

These areas are flat and if thoroughly dry, interim cover could be placed easily.

The length of time required for drying prior to placement of cover is site-specific and will vary depending on impoundment design, climate, and hydrogeology. Some impoundments, particularly those in climates characterized by high net evaporation and permeable soils (e.g., New Mexico) would dry sufficiently in a relatively short time,

1 year for example. Heavy equipment could access most of the area at that time. Other sites having lower evaporation, more rainfall/snowfall and/or less permeable soils that limit seepage could require considerably longer to dewater and dry (5 to 10 years for example).

Placement of 0.3-meter cover on these dry areas is demonstrated technology and is an NRC recommendation during standby to control windblown tailings.

Interim Cover on Lined Type 2 and Type 3 Impoundments

Tops of lined impoundments represent 14 percent of the total area.

Dry areas on lined impoundments make up 11 percent of currently dry areas.

Issue of lost capacity is more important on these impoundments because their construction cost is greater.

The dry out period will be longer than in unlined piles because seepage is limited.

Evaporation Ponds

In addition to tailings impoundments, several mills use evaporation ponds for water management. Decant water from the tailings impoundments and often mine pump-out water and seepage from the tailings impoundment is pumped to these evaporation ponds. Some tailings slimes and dissolved radium-226 are carried along with the water and are deposited in these ponds. Upon drying, these solids emit radon-222. Interim cover was applied to dry areas of evaporation ponds in the Draft BID. In the current evaluation, interim cover is not applied to evaporation ponds because: 1) these ponds receive water from sources other than tailings impoundments and would need to remain in service during standby periods; 2) the quantity of tailings present and their contribution to the site's source term are not accurately known; 3) these ponds will eventually be excavated and the material placed on the tailings impoundments prior to reclamation; and 4) these ponds are lined to prevent seepage. Movement of heavy equipment on these ponds could destroy the integrity of the liners.

Summary of Applicability

Because of the significant uncertainties and perceived difficulties and complications associated with the application of

interim cover to the outward faces of dams constructed of coarse tailings, in addition to the relatively lower source term of these areas, the current evaluation of interim cover assumes that these slopes remain uncovered. All other tailings surfaces can be covered as soon as they are dry enough to support earthmoving equipment and the cover itself. In this evaluation of interim cover, it is assumed that dry areas of evaporation ponds are not covered for the reasons stated above.

2.4 Timing of Interim Cover

The evaluation of interim cover includes several assumptions that are based on best engineering judgment, regarding the timing of interim cover applications (i.e., when can interim cover be applied). The assumptions are specified below:

Dry areas (as specified in Table 4-2 of the BID) of tailings impoundments that are on standby status or that have been filled to capacity can be covered immediately.

Wet and ponded areas of tailings impoundments that are on standby status or that have been filled to capacity will dewater and dry over a 5-year period, at which time it is assumed interim cover could be applied.

Interim cover is not applied to operating impoundments. The method of placing tailings in impoundments is to discharge from several points around the perimeter or to move the discharge point around the perimeter; in either case interim cover would not be compatible with these operations. These impoundments receive interim cover when they go to standby status (i.e., dry areas covered immediately, wet and ponded areas covered in 5 years).

The useful life of an interim cover is limited by return to active status at which time the earthen cover is covered with new tailings. In the current evaluation, impoundments would become active sometime between 1990 and 1995 and a second application of interim cover would be made in the year 2000.

It was initially assumed for the base case that an inactive impoundment would remain uncovered for 40 years. This appears unrealistic and a shorter time period of no more than 20 years is more representative.

2.5 Operational Aspects

The effectiveness of an unmaintained interim cover in limiting the escape of radon-222 can be expected to deteriorate with time. The rate of deterioration is highly site-specific. It depends upon many variables such as frequency and intensity of precipitation and wind, characteristics of the interim cover (e.g., moisture content, type of soil, compaction, grade, etc.), and drainage basin considerations (e.g., run-on and run-off). To prevent or minimize deterioration of interim covers, maintenance practices would be employed. Annual maintenance would include periodic regrading or placement of additional cover material. Additionally, periodic inspections of the interim cover system would be required to ensure its integrity. Such expenses are estimated to be 5 percent of the capital cost of the interim cover per year.

One important aspect regarding interim cover is the issue of lost capacity. An interim cover of 1 meter applied over a tailings impoundment that is on standby status results in a loss of tailings capacity equal to the cover volume. If interim cover is applied more than once (i.e., a covered impoundment goes from standby to operational status and back to standby), the effect of lost capacity is multiplied. Information received from the NRC on the capacity of existing piles and the capacity loss associated with an application of interim cover is presented in Table 2-1. Some impoundments would have no remaining capacity if interim cover were applied, while others would lose as little as 9 percent of their remaining capacity. Information on the remaining capacity at other sites is not currently available.

Table 2-1. Lost capacity associated with a single application of interim cover (0.9 m) over the entire impoundment in nonagreement states ^(a)
(1000 tons)

Mill	Current tailings	Licensed quantity of tailings	Quantity of interim cover - 0.91 meter thick (% of remaining capacity)
White Mesa	1,500	5,137	1,958 (54)
La Sal	2,954	5,041	205 (10)
Moab	10,600	15,600	1,176 (24)
Shootaring Canyon	174	5,000	411 (9)
Gas Hills (Pathfinder)	11,762	20,468	793 (9)
Split Rock	7,700	8,000	500 (100)
Gas Hills (UMETCO)	9,600	9,900	1,023 (100)
Bear Creek	4,100	5,700	882 (55)
Shirley Basin	6,800	8,800	1,364 (68)
Sweetwater	3,900	9,100	1,764 (34)

(a) NRC Uranium Field Office, Denver, Colorado, April 1986. Information on remaining capacity of impoundments in agreement states was not available.

REFERENCES FOR CHAPTER 2

- ORNL 83 Oak Ridge National Laboratory, "Guidance for Disposal of Uranium Mill Tailings: Long-Term Stabilization of Earthen Cover Materials," Prepared for U.S. Nuclear Regulatory Commission, NUREG/CR-3199, ORNL/TM-8685. October 1983.

o



EPA 520/1-86-009
August 1986

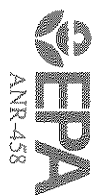

United States
Environmental Protection
Agency
Washington, D.C. 20460

Official Business
Penalty for Private Use
\$300

Radon - 222 Emissions from
Licensed Uranium Mill Tailings

Background
Information Document