

ENVIRONMENTAL PROTECTION AGENCY**40 CFR Parts 122, 123, 124, and 125****[FRL-1453-4]****Consolidated Permit Application Forms for EPA Programs****AGENCY:** Environmental Protection Agency.**ACTION:** Publication of consolidated permit application forms.

SUMMARY: Elsewhere in today's Federal Register, EPA has published final consolidated regulations for several permit programs administered by the Agency. As part of its consolidation of permit programs, EPA is also developing a set of consolidated application forms for several of its permit programs.

The complete set of consolidated application forms will consist of a brief general form requesting information common to all the consolidated permit programs (including an identification of the facility and a general description of the various pathways by which the facility releases pollutants to the environment) and several supplemental program-specific forms. Several of these forms, drafts of which were published for public comment on June 14, 1979 (44 FR 34346), are now available for use and are published in this notice. These are:

Form 1—the general form for all applicants.

Form 2b—a supplemental form for concentrated animal feeding operations and aquatic animal production facilities applying for National Pollutant Discharge Elimination System (NPDES) permits under the Clean Water Act.

Form 2c—a supplemental form for existing industrial dischargers applying for NPDES permits.

Form 3—a supplemental form for hazardous waste management facilities applying for hazardous waste treatment, storage, or disposal permits under the Resource Conservation and Recovery Act.

Additional forms will be developed in the future, as explained in the Supplementary Information section below.

The consolidated application forms have been designed for use by applicants for EPA permits. States with EPA-approved permit programs may adopt the EPA format in developing their own forms, or they may develop forms which differ from EPA's, provided that their forms require submission of the information required by 40 CFR Part 122 of the consolidated permit regulations. EPA encourages States to consolidate their application forms in a

manner which will, like EPA's consolidated form, provide complete summaries of facilities' total releases of pollutants to the environment.

The Supplementary Information below discusses extensively the NPDES permitting strategy and related regulations, as well as the application forms. Drafts of the forms and proposed regulations and discussion of the permitting strategy were published together in Part III of the June 14, 1979 Federal Register (44 FR 34346). Today, the final regulations are published as part of the consolidated regulations. However, the regulations relating to the application requirements and permitting strategy are discussed here rather than in the preamble to the consolidated regulations to again allow a unified, detailed discussion of the future direction of the NPDES program.

DATES: Forms 1, 2b, 2c, and 3 must be used in accordance with the following schedule:

1. New concentrated animal feeding operations and aquatic animal production facilities applying to EPA for NPDES permits must submit Forms 1 (EPA Form 3510-1, OMB No. 158-RO175) and 2b (EPA Form 3510-2b, OMB No. 158-RO174). EPA Form 7550-7 (OMB No. 158-RO103) will be superseded. Any existing facility applying for a new permit must submit Forms 1 and 2b, unless its permit expires on or before November 30, 1980 and it has already submitted EPA Form 7550-7. See 40 CFR 122.53(c) (published elsewhere in today's Federal Register) for information on deadlines for submission.

2. Any existing industrial (manufacturing, commercial, mining or silvicultural) facility applying to EPA for an NPDES permit must submit Forms 1 and 2c (EPA Form 3510-2c, OMB No. 158-RO173), unless its permit expires on or before November 30, 1980 and it has already submitted EPA Forms 7550-8, 7550-9 or 7550-23. Forms 7550-8, -9, and -23 are superseded for all such dischargers applying after May 19, 1980. However, they must still be used by NPDES new sources and new dischargers until Form 2d is made available. See 40 CFR 122.53(c) for information on deadlines for submission.

3. Hazardous waste management facilities must submit Forms 1 and 3 (EPA Form 3510-3, OMB No. 158-S80004) to EPA no later than 180 days after promulgation of 40 CFR Part 261. (These facilities must also submit brief notification forms to EPA no later than 90 days after promulgation of 40 CFR Part 261, See 45 FR 12746, February 26, 1980.)

FOR FURTHER INFORMATION CONTACT:

1. Forms 1, 2b, and 2c: Fanny Knox or Dov Weitman, Permits Division (EN-336), Environmental Protection Agency, 401 M Street SW, Washington, D.C. 20460 (202) 426-7010.

2. Form 3: Art Glazer or Allen Pearce, Office of Solid Waste (WH-563), Environmental Protection Agency, 401 M Street SW, Washington, D. C. 20460 (202) 755-9150.

SUPPLEMENTARY INFORMATION:

Contents of this Preamble:

I. Overview of Consolidated Application Forms

II. General Application Requirements for All Permit Programs: § 122.4 and Form 1

III. NPDES Forms 2b and 2c and Related NPDES Regulations

A. Introduction

1. Overview of this Preamble Discussion

2. Use of a Single Form for all Existing Industrial Dischargers

B. Strategy for Issuing Permits to Control Discharges of Toxic Pollutants

1. General Approach to Permit Writing

2. New Regulations to Insure the Control of Toxic Pollutants

a. Summary of Requirements

i. Requirement to Control all Significant Discharges of Toxic Pollutants through Permit Limits: § 122.62(e)

ii. Regulation of Toxic Pollutants not Limited in Permits

(A) Notification of Increased Discharges of Toxic Pollutants: § 122.61(a)

(B) Modification of Permit to Control Increased Discharges of Toxic Pollutants: § 122.15(a)(5)(viii)-(x)

b. Discussion of Changes from Proposed Requirements

3. Toxicity-based Limits: § 125.3(c)(4)

4. Indicator Limits to Control Toxic Pollutants or Hazardous Substances: §125.3(g)

C. NPDES Application Requirements for Concentrated Animal Feeding Operations and Aquatic Animal Production Facilities: § 122.53(e) and Form 2b

D. NPDES Application Requirements for Existing Industrial Dischargers: § 122.53(d) and Form 2c

1. General Discussion of Requirements; Public Availability of Information

2. Required Analyses and Estimates of Pollutant Discharges

a. Toxic Pollutants: § 122.53(d)(7)(ii) and (v) and item V-C

b. Other Pollutants

i. Required Analyses: § 122.53(d)(7)(i) and item V-A

ii. Required Reporting of Presence or Absence and, if Present, Required Analyses: § 122.53(d)(7)(iii) and item V-B

iii. Required Reporting of Presence or absence of Asbestos and Hazardous

- Substances: § 122.53(d)(7)(iv) and item V-D
- c. General Concerns in Sampling, Analysis and Reporting of Testing Results
 - i. Sampling Requirements
 - ii. Reporting of Analytical Testing Results
- (A) Detection Limits
- (B) Miscellaneous
- d. Response to Comments Advocating Biological Monitoring for NPDES Permit Applications
- 3. Other Application Requirements
 - a. Outfall Location: § 122.53(d)(1) and item I
 - b. Flows, Sources of Pollution and Treatment Technologies: § 122.53(d)(2)-(4) and item II
- c. Maximum Production: § 122.53(d)(5) and item III
- d. Currently Required Construction, Upgrading or Operation of Waste Treatment Equipment: § 122.53(d)(6) and item IV
- e. Potential Discharges of Toxic Pollutants
 - i. Toxic Pollutants Used or Produced by the Applicant: § 122.53(d)(9) and item VI-A
 - ii. Predicted Potential Increases in Discharges of Pollutants: § 122.53(d)(10) and item VI-B and C
- f. Results of Previous Biomonitoring: § 122.53(d)(11) and item VII
- g. Laboratory Conducting Analyses: § 122.53(d)(12) and item VIII
- h. Other Information Required by the Director on a Case-by-Case Basis: § 122.53(d)(13)
- 4. Proposed Application Requirements Deleted from the Final Regulations and Form
 - a. Optional Reporting of Discharges of Hazardous Substances
 - b. Submission of Data on Additional Pollutants
 - c. Ancillary Activities which May Result in Discharges of Toxic Pollutants or Hazardous Substances—Best Management Practices Programs
- E. Monitoring Requirements
 - 1. Chemical Monitoring
 - 2. Biological Monitoring
- F. Economic and Resource Impacts
 - 1. Unit Costs of Sampling and Analysis
 - 2. Unit Reporting Costs
 - 3. Total Incremental Costs
 - 4. Economic Impact Upon Selected Industries
 - 5. Impact Upon Independent Laboratory Capacity
 - 6. Small Business Exemption
 - a. General
 - b. Coal Mines
- IV. Part A of Hazardous Waste Application Requirements: § 122.24 and Form 3

I. OVERVIEW OF CONSOLIDATED APPLICATION FORMS

Today EPA is publishing in final form the first major regulatory products of its permits consolidation efforts. These products, which were proposed on June 14, 1979 (44 FR 34244 and 44 FR 34346), are consolidated permit regulations and a consolidated set of permit application forms.

The consolidated permit regulations are designed to promote consistency in several of EPA's established and newly-developed permit programs. The regulations are promulgated as 40 CFR Parts 122-124 elsewhere in today's Federal Register. They apply to five permit programs:

- (1) The Hazardous Waste permit program under section 3005 of the Resource Conservation and Recovery Act (RCRA);
- (2) The Underground Injection Control (UIC) permit program under Part C of the Safe Drinking Water Act (SDWA);
- (3) The National Pollutant Discharge Elimination System (NPDES) permit program under section 402 of the Clean Water Act (CWA);
- (4) The Dredged or Fill Material permit program under section 404 of CWA; and
- (5) The Prevention of Significant Deterioration (PSD) permit program under Part C of the Clean Air Act (CAA).

The EPA consolidated application forms will be used by applicants for EPA-issued permits under the above permit programs. However, since EPA does not issue any permits under the dredged or fill material program, it is not developing a form for that program. (These permits are issued by the U.S. Army Corps of Engineers and by States approved by EPA.)

The consolidated application forms will, when complete, consist of the following:

- Form 1—General Information (all permits).
- Form 2—Discharges to Surface Water (NPDES permits).
 - a. Publicly Owned Treatment Works.
 - b. Concentrated Animal Feeding Operations and Aquatic Animal Production Facilities.
 - c. Existing Manufacturing, Commercial, Mining and Silvicultural Operations.
 - d. New Manufacturing, Commercial, Mining and Silvicultural Operations.
- Form 3—Hazardous Waste Information Summary (RCRA permits).
- Form 4—Underground Injection of Fluids (UIC permits).
- Form 5—Air Emissions in or near Attainment Areas (PSD permits).

The above organization differs slightly from that set out in the June 14 notice. In that notice, EPA proposed to combine all application requirements for proposed facilities into a single form. Upon reconsideration, EPA has determined that, apart from the common elements consolidated in Form 1, the informational needs of the various programs differ significantly for proposed sources as well as existing sources. Thus it makes sense to keep them separate, as outlined above.

This notice contains Forms 1, 2b, 2c, and 3, which must be used as set forth above under "Dates." As mentioned in the June 14 preamble at page 34347, EPA had hoped to publish drafts of Forms 2a, 2d (proposed Form 5), and 5 in December 1979. Forms 2a and 2d have been delayed somewhat due to the need to concentrate Agency resources on finalizing Forms 1, 2b, 2c, and 3, and on promulgating final consolidated regulations. Development of Form 5 has been delayed as a result of *Alabama Power v. Costle* (D.C. Cir., 1979), which required EPA to substantially revise several major aspects of the PSD program regulations. EPA currently anticipates that drafts of Forms 2a, 2d, and 4 will be published in June 1980. The date for publication of a draft of Form 5 is currently uncertain. Applicants for PSD permits should contact their local EPA Regional offices for information on how to apply for PSD permits pending availability of Form 5.

The set of consolidated application forms are required to be used only for applications to EPA. Where approved States have permit-issuing authority, they may use their own forms. These forms must, however, require at least the information required by the application requirements contained in 40 CFR Part 122. In addition, States may require information beyond that required by EPA. EPA encourages States to consolidate their programs and forms and hopes that the EPA consolidated application forms will provide a useful model to the States.

Of course, States may choose to use EPA's forms. EPA has in the past provided NPDES forms to States wishing to use EPA forms. This practice will continue in the future for all of the consolidated permit application forms.

States may be able to consolidate State permit application forms for permit programs other than those covered by EPA's consolidated forms, such as State dredged or fill material application forms. Combination of forms for PSD and nonattainment permit applications under Parts C and D of the Clean Air Act might prove particularly useful.

One commenter suggested that EPA require States to use the same form as EPA. This suggestion has not been adopted, because States are allowed by the applicable laws to have more stringent application requirements than EPA. In addition, EPA sees no compelling need to require a uniform application form in all States. Inclusion of uniform minimum application requirements in 40 CFR Part 122, coupled with EPA approval of State program forms under 40 CFR 123.4(d), will provide sufficient uniformity to meet program needs.

EPA was pleased to receive generally favorable comments from the public on the concept of consolidating the application forms. As Citizens for a Better Environment pointed out, this consolidation will not only reduce paperwork but will also provide a "concise and clear record of the ultimate fate of all of the pollutants generated by a facility, whether these pollutants are discharged to air, water or land." States were also supportive of EPA's effort.

Some industry commenters did, however, express two major concerns, although in general they did not object to the concept of consolidating application forms.

The first concern expressed by industry was an extension of the general concerns raised about the consolidated permits regulations: that application and permit requirements of one program should not be applied to another program and that application procedures under one program should not be allowed to delay procedures under another program. EPA agrees that consolidation should not affect substantive requirements of applicable law and that consolidated procedures should be used to expedite rather than delay permit issuance. The preamble to Parts 122 and 124 of the consolidated regulations discusses these issues in detail. The important point is that different program-specific application forms (e.g., Forms 2c and 3) may be submitted separately and, if necessary to avoid delay, processed separately.

The second concern expressed by commenters from several industries (particularly farming and coal mining, but also oil and gas producing, steam electric generating, and cement and concrete industries) was that industry-specific forms should be developed for each industry, resulting in simplification for applicants. EPA agrees that development of industry-specific forms may be useful in certain situations, although administrative resource constraints generally preclude such development for each regulated industry. EPA has been able to take

steps to develop specific requirements for the farming and coal mining industries. EPA has separated agricultural and aquatic operations from all other dischargers of pollutants by developing Form 2b. Similarly, EPA is working with the Department of the Interior's Office of Surface Mining to develop a consistent set of specific application requirements for the coal mining industry (see section III.F.6.b of this preamble; see also 44 FR 55322, September 25, 1979).

II. GENERAL APPLICATION REQUIREMENTS FOR ALL PERMIT PROGRAMS: § 122.4 AND FORM 1

Form 1 of the consolidated application forms requires identification of the applicant and general information showing the various pathways by which the facility releases pollutants to the environment. This information is used by the applicant to determine what permits are needed by the facility and which supplemental forms must be submitted in addition to Form 1. Most of the requirements of Form 1 also appear in § 122.4 of the consolidated regulations.

The June 14 draft of Form 1 has been changed in some minor respects in the final version. In addition, the instructions have been shortened and clarified by deleting repetitive information and making appropriate editorial changes. The instructions have also been amended to reflect program changes in the final consolidated (and other program) regulations and to reflect the changes in the PSD program required by *Alabama Power v. Costle*.

Divergent philosophical viewpoints were expressed in comments by industry and environmental groups. Several industry commenters referring to Items II (draft-item I) and XI (draft item X) questioned EPA's authority to require information not directly related to the applied-for permits. Item II requires a facility applying for a permit under one program to state whether or not it engages in any activity regulated under any of the other consolidated EPA permit programs. Item XI requires submission of a map showing the various types of wastes which the facility releases to the environment and the various ways those wastes are released. For example, a facility needing an NPDES permit must also state whether it treats, stores or disposes of hazardous waste and, if so, must show on a map where it does so.

Environmentalists argued to the contrary that Form 1 should require much more detailed information showing the movement of all waste stream components in an industrial

process, from the introduction of raw materials through processing to ultimate release.

EPA has concluded, after considering both the industrial and environmental arguments, that the middle course which it adopted in draft Form 1 should be retained as the most suitable one for the form's purposes. EPA believes that responsible environmental management requires a unified examination of a facility's total residual waste stream. In recent years, the interrelation of various environmental programs has become increasingly clear. See, for example, section 1006 of RCRA, requiring EPA to integrate all provisions of RCRA, for purposes of administration and enforcement, with the appropriate provisions of the Clean Air Act, Clean Water Act, Safe Drinking Water Act, and certain other environmental laws administered by EPA.

EPA is responding to this need through its consolidated permit regulations and through its consolidated application forms, particularly Form 1. Because the burden on a facility to list and to indicate on a map its releases of pollutants to the environment is minimal, the environmental benefit of providing this information is not counterbalanced by a substantial burden on industry.

However, because of the differing informational needs of the various consolidated programs, the detailed information desired by the environmental commenters is not required by Form 1. Rather, any detailed information required to make permit issuance decisions under a particular program should be requested in that program's supplemental form. Form 1 thus functions as a "road map," leading the applicant to the detailed informational requirements relevant to its operation.

Specific items on Form 1 which were of interest to commenters are discussed below:

Item I (item II in the June 14 draft of Form 1): EPA has renamed the "Facility ID Number;" it will now be referred to as "EPA ID Number." In response to comments (particularly from farmers and oil and gas producers) that Dunn and Bradstreet (DUNS) numbers have not been assigned to certain facilities and are difficult to obtain, EPA has decided to provide DUNS numbers to facilities before they fill out their applications. In many instances, the ID number (which will be obtained by EPA from Dunn and Bradstreet where none has existed previously) will be on a preprinted label mailed to the applicant which contains items I, III (facility name), V (facility mailing address), and

VI (facility location). In other instances, EPA will indicate the ID number on the outside of the envelope used to mail the application form to the applicant.

Item II (item I in the June 14 draft): A third column has been added to this item, as requested by some commenters, for applicants to indicate which supplemental forms are being submitted in addition to Form 1. EPA has also adopted a comment requesting that the instructions state that a facility which answers yes to a question but which already has a permit covering that activity need not file a new application, unless the applicant is filing for a permit renewal. Some commenters correctly noted that question E was overly broad. Questions E through H have been redrafted to clarify that only information related to the facility seeking a permit is requested and not, for example, information concerning hazardous waste disposed of by the same owner or operator at a different facility in a distant location.

Item IV: Two environmental commenters requested that each applicant be required to list a telephone number at which a technically competent person could be reached 24 hours a day. EPA believes this is unnecessary. It is true that the Hazardous Waste Permit Program appropriately requires each facility that treats, stores or disposes of hazardous waste to have an emergency coordinator present or on call (40 CFR Part 264). However, different people are likely to function as emergency coordinators at different times; thus the identification of a single person or phone number in the application is likely to become obsolete soon after the application is filed. In the event of an emergency needing immediate attention by the permittee during non-business hours, high-level officials of the permitted facility may generally be contacted immediately without difficulty. Moreover, the National Responses Center may be reached 24 hours a day at 800-424-8802 to respond to emergencies requiring immediate assistance or advice.

Item VII: Several commenters requested clarification concerning SIC codes. The purposes of requesting SIC codes are: (1) to provide permit writers with an additional means of checking whether wastes or pollutants listed on a supplemental form include all of those which the applicant might be expected to release; (2) to provide one means for NPDES and PSD permit writers to determine whether a particular industry guideline or standard applies; and (3) to provide a data base to assist EPA in correlating industrial subcategories

(indicated in Item VII) to types of wastes or pollutants being released to the environment (indicated in Item II). EPA recognizes that determining SIC codes is an imprecise exercise and requires simply that each applicant use its best judgment to list at most four SIC codes, in order of priority, which most accurately define goods (final or intermediate) and services created or produced by the applicant. Applicants needing assistance in answering the question are now directed by the instructions, as suggested by one commenter, to contact their EPA Regional offices.

Two commenters noted that off-site hazardous waste management facilities have no specific SIC code; in such cases, SIC code 9999 ("nonclassifiable establishments") would apply. The number 9999, together with the applicant's responses to item I, Question E and item XII will indicate that the facility is an off-site HWM facility.

Item VIII: Commenters correctly noted that facilities may be operated and applications may be submitted by persons who are not owners. Form 1 now presumes that the applicant is the operator of the facility. It should be noted that 40 CFR 122.6, which applies to the NPDES, Hazardous Waste and UIC programs, provides: "Where a facility or activity is owned by one person but is operated by another person, it is the operator's duty to obtain a permit." An additional question has been added to determine whether the operator/applicant is also the owner of the facility.

Item IX: A new item asks whether the facility is located on Indian lands. The significance of this question is jurisdictional; see 40 CFR 123.1(f) and the accompanying preamble discussion. A reference in draft item VIII-C to Indian lands was deleted, since that item is designed to identify the status of the operator, not of the land itself.

Item X (draft item IX): One commenter questioned the need for more than one permit number per facility. EPA does intend in the future to use a common number for each permit issued to a particular facility (except for a one-letter prefix indicating under which program the permit has been issued). However, existing NPDES and PSD permits as well as future permits under "other" permit programs, necessitate provision in the form for insertion of permit numbers.

A few commenters objected to this item and suggested that only Federal permits or only permits relevant to the one applied for be required. However, EPA believes that identification of the various environmental permits issued to the facility will promote cooperation

among various agencies and offices in regulating the facility and will ultimately benefit the facility as well.

Item XI (draft item X): Several commenters objected to the requirement that the map extend at least one mile beyond the facility boundaries. However, this requirement has been retained, since the disposal or discharge of wastes is likely to pollute the adjacent environment through such means as surface or ground water movement.

Several other commenters correctly noted that U.S. Geological Service topographic maps at appropriate scale are unavailable for certain regions of the United States. The instruction to this item have therefore been modified to allow the use of a plat map or other appropriate map where an appropriately sized topographic map is unavailable.

Several commenters suggested that applicants not be required to show certain items on the map (e.g., rivers which do not receive any discharge, and rivers, wells and springs uphill of a facility). EPA notes, however, that these features are often relevant to an understanding of the geological and hydrological consequences of a discharge or disposal at the site. Furthermore, most of this information is generally indicated on U.S.G.S. maps and requires no work by applicants.

Several commenters (particularly oil and gas producers) correctly pointed out that an instruction to this item was overly broad in requiring identification on a map of all wells contained within one mile of the facility's property boundaries. The requirement is now limited to drinking water wells identified in the public record or otherwise known to the applicant.

Some commenters suggested further that the map should only show such wells within ¼ mile of the facility. EPA has accepted this suggestion. In light of the slow movement of groundwater, this information should be sufficient to prevent well contamination in cases where the groundwater becomes contaminated through faulty waste disposal or other practices.

Item XIII (draft item XII): See 40 CFR 122.6 and the accompanying preamble, published elsewhere in today's Federal Register, for a discussion of certification and signatory requirements.

Several environmental commenters requested that latitude and longitude information be required on Form 1. EPA has decided to require this information on appropriate program-specific forms. Forms 2c and 3, published today, require this information. By using the program-specific forms to require latitude and longitude, EPA obtains more precise

coordinates when wastewater dischargers and hazardous waste disposal facilities are several miles apart.

III. NPDES FORMS 2b AND 2c AND RELATED NPDES REGULATIONS

A. Introduction

1. Overview of This Preamble Discussion

The NPDES regulations on application requirements for existing industrial discharger and the new EPA application form for those dischargers (Form 2c) have been developed primarily to help implement the Agency's strategy for the control of discharges of toxic pollutants designated under section 307(a) of the Clean Water Act in the next round of permit reissuances. Because the application requirements and permitting strategy are closely related, the application form and regulations were published together as Part III of the June 14, 1979 Federal Register (44 FR 34393). The proposed regulations and draft Form 2c were prefaced by a lengthy preamble, which explained the context in which the NPDES application and related requirements were developed. The discussion covered the need for a case-by-case determination of limits in the absence of effluent limitations guidelines, the use of limits on toxicity and indicator parameters, the requirement to analyze for the 129 toxic pollutants, the purpose of application-based limits, some suggested monitoring schemes to be required by permits, and the economic and resource impacts of the reporting requirements.

The regulations which were proposed in Part III of the June 14, 1979 Federal Register are published in final form elsewhere in today's Federal Register as part of EPA's consolidated permit program regulations. This is being done so that all program regulations may be read in one place. However, this preamble, rather than the preamble to those regulations, will discuss the topics and regulations relating to the NPDES application requirements and permitting strategy to explain the final regulations in a unified manner and to respond to comments received on the proposal.

The following regulations which are promulgated as part of the consolidated permit regulations are discussed in this preamble instead of in the preamble to the consolidated permit regulations:

1. § 122.53(d): Application requirements for existing industrial dischargers (paralleling Form 2c).

2. § 122.53(e): Application requirements for concentrated animal feeding operations and aquatic animal

production facilities (paralleling Form 2b).

3. § 122.61(a): Application-based notification requirements for toxic pollutants.

4. § 122.15(a)(5)(viii)-(x): Modification of permits to address toxic pollutant discharges not anticipated in applications or permits.

5. § 122.62(e): Requirement to set case-by-case limits to control significant discharges of toxic pollutants.

6. § 125.3(c)(4): Toxicity-based limits.

7. § 125.3(g): Indicator limits.

2. Use of a Single Form for all Existing Industrial Dischargers

Some commenters expressed concern that existing Short Forms C and D for simple discharges are not being replaced by new short forms; rather Form 2c must be used. The reason is that determining "simple" discharges is complex, given the new emphasis on toxic pollutants. Many factors would be relevant in determining "simplicity," such as size of flow, toxicity of discharge, and type of operations producing discharges. Factors relevant to the need to respond to one application requirement may not be relevant to another. For example, although flow was used as a criterion for determining who must fill out Short Forms C and D, the new form requires a primary industry discharger with a small flow to test for toxic pollutants, while a secondary industry discharger with a large flow may not need to do so.

EPA has simplified Form 2c and clarified the instructions to assist applicants in completing the form rapidly. Some of the more burdensome requirements will immediately be understood not to apply to simple non-toxic discharges and therefore may be marked Not Applicable. For example, any secondary industry discharger which does not discharge any toxic pollutants or hazardous substances need not test for pollutants in item V-C, list toxic pollutants in item VI-A or hazardous substances in item V-D, or predict future increases of toxic pollutant discharges in item VI-B and C. Similarly, many of the remaining questions also apply only to certain applicants. Item II-C applies only to applicants with intermittent or seasonal discharges. Item III applies only to applicants whose discharges are covered by effluent guidelines. Item IV applies only to applicants subject to waste treatment construction schedules. Item VII applies only to applicants who have conducted biological monitoring tests.

A few commenters suggested that Form 2c require only minimal information, with the permit writer able

to go back to the applicant to ask for any additional information. However, this would impose too great a burden on the permit writer. It also would result in the imposition of unequal burdens on similar applicants.

B. Strategy and Regulations for Issuing Permits To Control Discharges of Toxic Pollutants

1. General Approach to Permit Writing

The 1977 Amendments to the Clean Water Act placed a new emphasis on the control of toxic pollutants in the NPDES program. EPA is implementing the Amendments by developing effluent limitations guidelines, water quality criteria, and test methods for these pollutants. EPA will soon begin applying the new statutory and regulatory standards to specific dischargers through the issuance of NPDES permits requiring dischargers to control toxic pollutants in accordance with limits reflecting the best available technology economically achievable (BAT), as soon as possible but no later than the statutory deadline of July 1, 1984.

The new permit writing strategy will be an extension of that used in issuing first-round NPDES permits. As before, permits must contain limitations reflecting the most stringent of technology-based, water quality-based, or other standards required by CWA (such as criteria for ocean discharges under section 403 and toxic standards or prohibitions under section 307(a)). For most organic toxic pollutants, however, numerical State water quality standards generally will not have been set by the time that the next round of permits are reissued. (Permits are issued for maximum terms of five years as required by CWA, and permits may not be reopened solely to incorporate new State water quality standards unless requested by the permittee.) Thus technology-based limitations will generally be the chief standard for setting permit limits on most toxic pollutants during the next round of permit reissuance.

The rules for setting technology-based limitations are set forth in 40 CFR 125.3. Technology-based limitations are generally established on the basis of effluent limitations guidelines promulgated under section 304 of CWA. As in the past, permit writers must set limits on a case-by-case basis under section 402(a)(1) of CWA to control discharges which are not covered by effluent guidelines. This will occur in two types of situations: (1) when new BAT effluent guidelines addressing toxic pollutants in the applicant's industrial category have not been promulgated or

have been withdrawn or remanded; or (2) when the applicant has certain discharges which are not covered by an otherwise applicable guideline.

The Agency has been developing new effluent limitations guidelines for toxic pollutants in accordance with the NRDC Settlement Agreement (*Natural Resources Defense Council*, 8 E.R.C. 2120 (D.D.C. 1976), modified 12 E.R.C. 1833 (D.D.C. 1979)) and with the 1977 Amendments to the Clean Water Act. To focus EPA's resources on the more widespread and significant toxics problems, Paragraph 8 of the NRDC Settlement Agreement allows the Agency to exclude certain categories of industries and certain types of pollutants from coverage under national effluent guideline regulations. For example, pollutants which have been found at only one or two plants in an industrial category need not be included in the guidelines for that category, and pollutants which are in general (though not always) adequately controlled by guideline limitations on other pollutants need not be explicitly limited in guidelines.

As recognized in Paragraph 8 of the NRDC Settlement Agreement and demonstrated in EPA and State experience in issuing NPDES permits, even if a discharger's category is covered by promulgated effluent limitations guidelines, the discharger may be discharging pollutants not adequately covered by those guidelines. A major feature of the Agency's NPDES permitting strategy is the development of ways to identify and address situations in which significant discharges of toxics are not covered by guidelines and thus must be controlled on a case-by-case basis.

Permit writers will use several sources of information to determine appropriate BAT limits in the absence of guidelines. These sources include development documents for effluent guidelines in draft or final versions, a treatability manual prepared by EPA, and any other information available to the permit writer (including information provided by the permit applicant). The treatability manual is a five-volume compilation of historical data on the levels of reductions of toxic pollutants achievable by various types of treatment equipment or methods, together with associated costs. The manual is being developed with the participation of several EPA offices, including the Effluent Guidelines Division. Thus, the information it contains should be consistent with that used to develop proposed effluent limitations guidelines. The manual will be continually updated to reflect any

new or newly discovered data on technologies and associated costs.

It would be inappropriate to promulgate the treatability manual as a regulation, as requested by several commenters, because the manual contains no requirements. Rather, it compiles and summarizes historical data; it does not state conclusions based on the data. Furthermore, EPA expects to continually update the manual to incorporate new or newly-discovered data. Any rulemaking proceeding would thus be endless.

EPA plans to publish a Federal Register notice announcing availability of the treatability manual in June 1980. Comments are welcome and will, where appropriate, be incorporated into future editions of the manual. More important, EPA emphasizes that the manual is not a binding document (unlike, for example, a promulgated effluent limitations guideline) but is merely one source of relevant information. The permit writer's case-by-case development of permit limits, based on information contained in the manual or elsewhere, remains subject to challenge under the appropriate procedures of 40 CFR Part 124.

EPA agrees with several commenters who advocated national uniformity of permit limitations for similar discharges. Promulgated effluent guidelines will guarantee uniformity for commonly-occurring discharges. Even when plant-specific discharges require individualized permit limits, the manual and other guidance developed by EPA should further promote national consistency. Of course, the very existence of plant-specific discharges implies a need to set permit limits for such plants which differ from those set for other plants within the same industrial category.

2. New Regulations To Insure the Control of Discharges of Toxic Pollutants

a. *Summary of Requirements.* Today's regulations provide that permit writers must set permit limits to control all significant discharges of toxic pollutants. Such a requirement is already implicit in section 301(b) of the Clean Water Act. However, today's regulations specify certain steps to see that this is done. The approach is two-fold, as follows:

(i) *Requirement To Control all Significant Discharges of Toxic Pollutants Through Permit Limits:* § 122.62(e). Significant discharges of toxic pollutants must be limited in the permit either directly or through the use of limits on other parameters which assure control of the toxic pollutants.

"Significant" pollutants are defined to include:

- Pollutants reported in the permit application at levels exceeding the level which the permit writer determines could be achieved by BAT; or
- Pollutants used or manufactured or expected to be used or manufactured as intermediate or final products or byproducts.

The fact sheet for each permit (see 40 CFR 124.56) must explain how the permit limits comply with this requirement.

(ii) *Regulation of Toxic Pollutants Not Limited in Permits.* All non-"significant" pollutants (i.e., those considered not likely to be discharged above BAT levels based upon the levels reported in the application or upon expected use or manufacture at the facility) need not be specifically controlled in the permit (although the permit writer retains authority to do so under § 125.3). This will allow permitting authorities to focus their resources on significant discharges of toxic pollutants. To prevent future significant discharges of non-limited pollutants, two regulatory requirements have been established:

(A) Notification of Increased Discharges of Toxic Pollutants: § 122.61(a)

A permittee must notify the permitting authority as soon as it becomes aware that:

- Some activity has occurred or will occur to cause it to discharge a toxic pollutant at more than the greatest of 100 µg/l (or 500 µg/l for 2,4-dinitrophenol and 2-methyl-4,6-dinitrophenol, 200 µg/l for acrolein and acrylonitrile, and 1 mg/l for antimony) or 5 times the maximum concentration reported for that pollutant in the permit application (or a different notification level established by the Director); or
- It has been begun or will begin to use or manufacture a toxic pollutant as an intermediate or final product or byproduct.

(B) Modification of Permit to Control Increased Discharges of Toxic Pollutants: § 122.15(a)(5)(viii)-(x).

The permit may be modified to control a toxic pollutant when:

- The permittee discharges or expects to discharge the pollutant at a level higher than can be achieved by BAT; or
- The permittee begins or expects to begin to use the pollutant or to manufacture it as an intermediate or final product or byproduct.

In developing the concept of significance for determining when permit limits should be set for toxic pollutants, when notification should be required, and when permits may be

modified, EPA considered commenters' suggestion that toxicity be used as a criterion. EPA has not accepted the suggestion; all pollutants listed as toxic under section 307(a) of the Clean Water Act must be controlled by BAT. The concept of significance is used only to determine which pollutants are likely to be discharged at levels greater than achievable by BAT and thus must be limited in the permit. An assessment of toxicity does not pertain to this determination.

b. Discussion of Changes from Proposed Requirements. This section discusses the proposed "application-based limits" regulation (proposed § 122.68(a)), its deletion from the final regulation in response to comments, and the Agency's rethinking which led to the regulations discussed in section (a) above.

In the June 14 proposal, EPA did not provide guidance on when toxic pollutants should be limited. While the preamble noted that "significant" toxics should be limited in permits, the proposed regulations did not contain the specific requirements promulgated today in § 122.62(e). On the other hand, the regulations and preamble focused upon the control of all present and future discharges not specifically limited through effluent guidelines or by setting case-by-case limits. The Agency proposed in § 122.68(a) a stringent approach of application-based limits: the discharge of any pollutant would have been limited to 5 times (or a higher multiplier if a certain showing could be made by a permit applicant) the level reported in the application (or to 5 times the pollutant's detection limit, if a zero discharge was reported), unless the pollutant was limited directly.

The proposed application-based limit was intended to serve two purposes. First, it would have assured some control over significant discharges identified in the permit application which were for any reason not otherwise controlled in the permit. Second, it would have assured control of future significant discharges of pollutants which were discharged at insignificant levels at the time of the permit application and thus were not specifically limited in the permit.

Commenters almost unanimously criticized proposed § 122.68(a), although a few industrial commenters stated that the proposed approach was reasonable and several environmental groups supported it with reservations. Most commenters argued that the proposed regulation would not contribute any substantial environmental benefits justifying the significant burden on all permittees and that it was insupportable

legally and technically. Some commenters suggested that EPA could better achieve its stated goals by focusing more closely at the permit-writing stage on those pollutants which are likely to be discharged at significant levels and by using notification requirements for other pollutants which first become significant after the permit is issued.

These comments, some of which were quite detailed and lengthy, convinced EPA that the imposition of application-based limits could not be supported at present and assisted the Agency in rethinking its approach to the problem of controlling discharges which are not covered sufficiently by effluent guidelines. The major comments are summarized below:

SUMMARY OF COMMENTS ON PROPOSED § 122.68(a) (APPLICATION-BASED LIMITS)

(1) *The values reported in the permit application may not be representative of existing or future discharges of pollutants,* both because of normal random fluctuations in concentration and because of future changes in processes or operations which were not anticipated in the permit application or which result in discharges not easily predicted. Insufficient data exist to select a multiplier which is adequate to relate the results of one sample to future discharges. If such data did exist, it would show that an appropriate multiplier would be much higher than five. Further variability is introduced by errors in sampling and analysis, variations of pollutant levels in intake water, and the use of batch processes which result in continually changing levels of pollutants. To avoid liability based upon an unduly low multiplier, applicants would have to spend a great deal of money for alternate testing to be eligible for a higher multiplier under proposed § 122.68(a)(3), and even then they could not be completely assured of compliance with that multiplier.

(2) *Setting permit limits on all reportable pollutants is an inappropriate and unduly costly way to regulate permittees' discharges.* Permittees could often be subjected to liability for minor violations (e.g., discharges at 50 µg/l). As a result, permittees would either have to spend a great deal of money on compliance monitoring to assure that they were complying with all application-based limits, or they would have to rely on assurances that, under EPA's enforcement discretion, only large violations would be prosecuted. It would be unfair to impose near-certain liability on dischargers on the assurance that they will not be enforced against except for significant violations. It would be particularly unfair when analysis of a pollutant had not been required or when the pollutant had not been detected in the sample(s) analyzed and thus had been reported as absent in the application.

(3) *Application-based limits are illegal.* The Clean Water Act requires permit limits to be based on technology-based, water

quality-based, or certain other standards; application-based limits are not authorized by any of these standards. In particular, application-based limits which are lower than the levels achievable by BAT (which would often occur where a pollutant was reported as zero in the application) are improper.

(4) *Pollutants of concern should be limited directly using technology-based limits, rather than indirectly using application-based limits.* EPA should focus on limiting significant discharges. Monitoring and reporting requirements should be rolled upon to assure the discovery and subsequent control of new significant discharges occurring after the permit is issued.

(5) *Existing NPDES regulations already provided sufficient controls over large potential discharges of pollutants not limited in the permit,* because (a) substantial changes in production were required to be reported and were grounds for permit modification, and (b) large discharges of pollutants not limited in the permit would have occurred only when permit limits on other pollutants would have been violated.

(6) *Application-based limits, if used at all in the final regulations, should be based on a multiple of the amount of discharged pollutants rather than on concentrations of the pollutants.* Otherwise, EPA would discourage desirable flow reduction practices.

(7) *Application-based limits could result in differing limits for dischargers in the same industrial subcategory.*

EPA does not agree with all of the above comments. In particular, EPA continues to believe that an application-based limit is legal if the multiplier accurately reflects waste stream variability. Any limit currently being achieved by a discharger is obviously no more stringent than the best available technology economically achievable. Thus if a variability-based multiplier times a reported value is the maximum level currently being discharged, it clearly may be adopted as BAT.

However, EPA is persuaded by the comments, considered collectively, that its proposed approach must be revised. In particular, EPA agrees with the commenters that the insufficiency of data on waste stream variability and the problem of continually changing feedstocks and batch processes both present severe technical difficulties for the concept of across-the-board application-based limits. Similarly, EPA acknowledges that the proposed approach had the potential for imposing unduly severe monitoring costs upon applicants wishing to demonstrate that a multiplier higher than 5 should be used and upon permittees wishing to assure that they are complying with application-based limits. Finally, EPA agrees that a better-focused alternative exists to address most of EPA's concerns.

The revised approach, as outlined above, focuses the permit writer's attention (in § 122.62(e)) more clearly than before on the specific control of all significant discharges of toxic pollutants by specifying various factors (reported discharge levels and the use or manufacture of toxic pollutants) indicating significance. The possibility that currently insignificant discharges of certain pollutants may be transformed later into significant discharges is addressed through notification requirements (§ 122.61(a)) and through an authorization to modify permits to address such problems (§ 122.15(a)(5)(viii)-(x)).

The multiplier used in § 122.61(a) as one means to trigger the notification requirement is still set at five, despite the comments criticizing it. The Agency believes that the available data supports a value of five to distinguish between random fluctuations and significant increases, at least for the purposes of a notification requirement. If the Director becomes aware of sampling or analysis errors, or fluctuations in pollutants in the intake water, the Director may modify the permit to establish a higher notification level to account for these fluctuations, as provided in § 122.62(f). Increases from other causes are exactly what this requirement was designed to regulate.

Two changes have been made, however, in the way the multiplier of five will operate in the notification requirement.

First, the lower threshold for notification has been raised to 100 µg/l (and higher for several pollutants which have high detection limits). Multiples of detection limits are not used as a basis for application-based notification.

Second, the multiplier applies to the maximum, rather than the average value reported in the application, of either the tested or the predicted value. This approach was suggested by some commenters. Of course, when only one sample is tested for toxic pollutants (which is all that is required), maximum and average values are identical. However, the maximum value has been defined to include values predicted by the applicant under § 122.53(d)(10) and item VI of Form 2c (discussed below in section III.D.3.e.ii). This change responds to several comments noting the difficulties in applying the proposed regulation to batch discharges and other nonrandom changes. Applicants are discouraged from reporting unrealistically high values in item VI by § 122.62(e), which requires that their permits contain limits to control toxic pollutants reported at levels greater than BAT under § 122.53(d)(10) and item VI.

Any variations in levels of pollutants which cannot be predicted at the time of the application will be subject to the notification requirements in § 122.61(a).

The requirement to submit 10 samples to get a higher multiplier has been deleted. The Director may set a higher notification level based on a higher maximum value, not a higher multiplier. Thus several comments received on the alternate multiplier provision (proposed § 122.68(a)(3)) no longer apply.

EPA recognizes that the revised approach falls short of the proposal in some respects. There is still some possibility (though less likely as the result of § 122.62(e)) that a permittee may discharge a large amount of a pollutant not limited in its permit, and EPA will not be able to take enforcement action against the permittee as long as the permittee complies with the notification requirements of § 122.61(a). Although EPA will now have authority under § 122.15(a)(5)(viii)-(x) to modify (or revoke and reissue) the permit to require control of the pollutant, permit modification can be a lengthy process.

EPA will continue to examine the problem of pollutants which are not limited in permits and to seek solutions to what it still considers to be a regulatory gap, although the gap is made smaller by the regulations published today. EPA welcomes suggestions on how best to develop a technically and legally supportable approach. In addition, the final regulations control discharges only of the pollutants listed in the permit application, which consist primarily of the listed toxic pollutants and designated hazardous substances. (Proposed § 122.68(a) also was limited to the pollutants listed in the application form.) This list is by no means exhaustive of all chemicals which may be discharged.

EPA intends to continue to study other pollutants, to make appropriate additions to the toxic pollutant and hazardous substance lists and to consider appropriate technological controls in the development of future effluent guidelines. Some of this work has already begun. However, some will not begin until currently listed toxics and hazardous pollutants are fully addressed.

Even at present, however, permit writers may set limits on any pollutant believed to be of concern. In certain cases, bioassays and further toxicity testing may result in the identification and control of additional harmful pollutants (see sections III.D.2.d and E.2 of this preamble).

The new authorities provided to EPA under the Toxic Substances Control Act

(TSCA) may help further to reduce threats of toxic discharges. Under TSCA, EPA may regulate the manufacture, use and disposal of toxic substances. Regulation under TSCA may indirectly (or, in certain instances, directly) result in the reduction or elimination of particular pollutants from discharges.

3. § 125.3(c)(4): Toxicity-Based Limits

§ 125.3(c)(4) provides that permit limits may be expressed in terms of effluent toxicity if they reflect the appropriate requirements of the Clean Water Act, such as technology-based or water quality-based standards. This aspect of the regulations is essentially unchanged from the proposal.

Several minor editorial changes have been made, including the elimination of the reference to subparagraph (c)(2), which implied that toxicity-based limits may be used only on a case-by-case basis. The regulation now provides that toxicity-based limits may also be applied in effluent guidelines, provided the requirements of subparagraph (c)(4) are otherwise met. At this time, however, EPA does not contemplate including toxicity-based limitations in forthcoming effluent guidelines.

Many comments were received concerning the issue of establishing toxicity-based permit limits. Many commenters expressed unqualified support for biomonitoring and toxicity-based permit limits, arguing that chemical limits alone are insufficient to control the many unknown toxic chemicals and the results of their interactions. Indeed, this issue was of great interest to many private citizens. Several other commenters agreed that toxicity-based limits are appropriate in certain situations but, because of the expense and delay involved in determining and enforcing such limits, argued that they should be used only for demonstrated toxic discharges when other limits are inadequate or unavailable. EPA agrees and is recommending that toxicity limits be used when (1) it is suspected that the discharge is toxic based on ongoing or previous toxicity testing or a history of fish kills or related toxicity problems, and (2) effluent guidelines are either absent, or it is believed that significant toxicity will remain in an effluent after the appropriate guidelines control technology is installed. Thus, toxicity-based limits should be used when the chemical limits approach is inadequate. Examples of such situations include primary industry discharges when the listed toxic pollutants are not found but serious toxicity problems exist, and

secondary industry discharges when chemical analyses are not required.

Several commenters expressed concern over the determination of toxicity limits by permit writers. They argued that toxicity-based limits should reflect BAT as defined in the Clean Water Act. Other commenters opposed rigid protocols, advocating instead that the most appropriate type of toxicity-based limits should be worked out between the permittee and permit writer to correspond to the particular situation. EPA agrees that toxicity-based limits must reflect BAT or other requirements of the Clean Water Act. EPA also agrees that considerable flexibility should be allowed the permit writer to determine the permit limits most appropriate for a particular situation.

There are two approaches for determining toxicity-based permit limits. The first approach is based on State water quality standards. All State standards include a statement to the effect that no toxic substances may be discharged in toxic amounts. Additionally, many States such as California and Arizona specify acute or chronic levels which are not to be exceeded and define methods of measurement and reporting. The second approach is technology-based; the permit writer makes a case-by-case determination of BAT or other appropriate technological standard, using his or her best professional judgment. Such determinations must be based on an evaluation of the available technology to achieve a particular toxicity reduction. For example, when information on treatability is lacking, studies can be conducted to assess the reduction in toxicity resulting from various treatment systems or process alternatives. Technology-based limits using toxicity units may then be set based on this data. EPA recognizes the significant cost of this procedure and recommends that it be used only when it is not possible to adequately control toxic chemicals using appropriate chemical limits.

Several commenters argued that because too much discretion was being allowed permit writers in setting toxicity limits, non-uniformity would result. EPA recognizes that some non-uniformity is inherent in a case-by-case approach, whether that approach uses chemically-based or toxicity-based permit limits. As discussed in section III.B.1 of this preamble, case-by-case limits are a necessary approach when applicable guidelines are not available or do not result in the installation of BAT for all pollutants. To assist the permitting authorities and to promote uniformity,

EPA has distributed the May 1, 1978, draft *Biomonitoring Protocol Guidance for the NPDES Permits Program*, which discusses the use of toxicity-based permit limits. In addition, a guidance document entitled *Use of Biological Toxicity Testing in the Second Round of NPDES Permit Issuance* is being developed and will be available in mid-1980.

EPA is continuing at present to rely primarily on chemical limits to control toxicity; therefore, toxicity-based limits will be employed only when these chemical limits are inadequate. The Agency believes, however, that toxicity testing and toxicity-based permit limits must play an ever-increasing role in order to address the problems of toxic pollutant control.

4. Indicator Limits To Control Toxic Pollutants and Hazardous Substances

§ 125.3(g). Proposed § 125.3(g), which established certain criteria for the use of limits on indicator parameters to control toxic pollutants, has been retained in the final regulations. However, a provision has been added in paragraph (g)(3) to preserve the discharger's ability to determine the most cost-effective method for reducing its discharges of toxic pollutants. In addition, paragraph (g)(2) has been added to provide for the use of indicator parameters to control hazardous substances, as proposed on August 29, 1979 (44 FR 50780). The use of indicators and final § 125.3(g) are discussed below. While the discussion below focuses on the control of toxic pollutants, most of the discussion pertains to hazardous substances as well.

a. *Outline of Strategy.* EPA generally will use the word "indicator" to refer to conventional and nonconventional pollutants used as authorized in § 125.3(g). Several commenters pointed out the BAT limits on toxic pollutants, BCT limits on conventional pollutants and modified (e.g., to BPT levels) limits on nonconventional pollutants may, in appropriate circumstances, be used as "indicator" pollutants. EPA agrees. However, the use of such pollutants as indicators does not require any new regulations.

As described above in section III.B.1 of this preamble, permit writers must set technology-based limits to control pollutants by applying guidelines or, in the absence of applicable guidelines, by setting case-by-case limits under section 402(a)(1) of CWA. In some cases, it is not feasible to set limits on each discharged pollutant. This is particularly true in the case of organic pollutants, because they can be expensive to sample and analyze and because there

is relatively limited experience and historical data demonstrating achievable levels of removals by various types of technology.

EPA believes that the most appropriate way to regulate toxic pollutants is to limit toxic pollutants. As discussed in section III.B.1 of this preamble, EPA has prepared a five-volume treatability manual, compiling data on treatability levels of specific toxic pollutants which have been achieved by particular technologies, to help permit writers to limit toxic pollutants directly when guidelines do not apply.

However, as noted above, direct limitation of all toxic pollutants in a waste stream is not always feasible. In such cases, limiting indicator pollutants (or selected toxic pollutants) is sometimes an appropriate alternative. When a certain treatment system is the most cost-effective method for limiting toxic pollutants, and where limits on certain other pollutants (e.g., BOD, COD, chromium and total phenols) found in the discharge would require installation of the treatment system, then those other pollutants are referred to as "indicator" pollutants.

The term "indicator" is not intended to denote a statistical relationship between the limited pollutants and the nonlimited toxic pollutants. It means simply that the limits on the indicators will reflect (i.e., result in installation of) the best available technology economically achievable to reduce discharges of the toxic pollutants. Note that the identification of BAT technology for the toxic pollutants does not require precise knowledge of the numerical levels of those pollutants to be achieved by installation of that technology. Of course, to be defensible as BAT, the general effectiveness of the technology as compared to alternative technologies must be known. Such qualitative relationships are more easily discerned and agreed-upon, based on existing treatability data, than the actual numbers which may be achieved to a desired confidence interval by the compared technologies.

An approach similar to the indicator approach was used frequently in developing existing BPT guidelines, although the term "indicator" was not used. Such guidelines include various mining (coal, ore, mineral) and metals industries. A typical example is the use of limits on pH, TSS, and one or two metals to assure the precipitation not only of the limited metals, but of others as well.

If a pollutant is used as an indicator for toxic pollutants, its limit must reflect BAT for those toxic pollutants. This is

clearly required by section 301(b) of CWA, which states that limits to control toxic pollutants must reflect BAT. Therefore, § 125.3(g) provides that, for conventional pollutants listed under section 304(a)(4) of CWA which are used as indicators for toxic pollutants, the Director may set limits at levels which are more stringent than the best conventional pollutant control technology (BCT). Similarly, for nonconventional pollutants (those not listed as either conventional or toxic pollutants) which are used as indicators for toxic pollutants, the Director may set limits which are not subject to modification under sections 301 (c) or (g) of CWA. (As one commenter pointed out, and as directly acknowledged in § 125.3(g)(2), nonconventional pollutants used as indicators for hazardous substances not listed as toxic under section 307(a) of CWA are subject to requests for 301 (c) and (g) modifications.)

EPA stresses that the Director may invoke § 125.3(g) only after establishing that direct limitation of the toxic pollutant is not feasible for economic or technical reasons and that limitation of the indicator will result in BAT-level control of the toxic pollutant discharges. The permit applicant may challenge the use of an indicator and offer evidence to support direct limitations of toxic pollutants. EPA intends to apply the indicator strategy reasonably, with toxic limits remaining the preferred approach whenever feasible.

b. *Response to Comments.* EPA received many comments on proposed § 125.3(g). The comments almost uniformly favored the use of indicators in appropriate circumstances when agreed upon by both the permitting authority and permit applicant. Several industries strongly encouraged the use of indicators. However, most commenters expressed reservations concerning the scope of proposed § 125.3(g).

Several commenters were concerned that proposed § 125.3(g) might authorize the Director to impose indicator limits which would require the discharger to control discharges of toxic pollutants in a cost-ineffective manner by requiring too stringent control of the indicator. For example, segregation of toxic waste streams, process changes and raw materials substitutions are possible means of controlling particular toxic pollutant discharges without controlling any parameter intended to serve as an indicator.

EPA agrees that limits on indicators should not be used to require greater or more expensive effluent control than would be required if all pollutants were

regulated directly. § 125.3(g) has therefore been amended by the addition of a requirement that the Director may not impose a more stringent limit on a pollutant intended to be used as an indicator when the limit would effectively require the permittee to use a method of treatment which differs from that which would be required if the toxic pollutants were limited directly. In the event that the Director uses an indicator limit in the draft or final permit that the discharger believes would preclude the use of more cost-effective measures to regulate the indicated toxic pollutants, the discharger can make appropriate objections challenging the limits under the procedures in 40 CFR Part 124.

Several commenters requested that the concurrence of the permittee be obtained before an indicator limit is set in the permit. Another requested simply that the permittee be given an opportunity to comment on the proposed use of indicator limits. EPA believes that it is administratively infeasible to obtain the permittee's concurrence in each situation before setting indicator limits. However, the procedures in 40 CFR Part 124, which include opportunities for permittees to comment on the draft permit, request an evidentiary hearing after the permit is issued (unless an expanded non-adversary hearing has been held during the comment period under Part 124, Subpart F) and appeal to the Administrator, will afford significant opportunity for permit writers and permittees to resolve disagreements. The strict restrictions placed by § 125.3(g) upon the use of indicators, together with the possibility of administrative and judicial review, will insure that permit writers do not use indicators improperly.

Some commenters argued that the limitation of conventional indicators beyond BCT and the denial of variance opportunities for nonconventional indicators is contrary to the requirements of CWA. EPA disagrees. When limits on indicators are used as a means to control toxic pollutants, they must reflect the best available technology economically achievable (BAT) to control the toxic pollutants. As long as the requirements of § 125.3(g) are met (i.e., that indicators be used only where direct limitation of toxic pollutants is infeasible and that indicators not be used to require control technology which is not needed to control the toxic pollutants), discharges will effectively be subject to precisely those technology-based requirements required by section 301 of CWA.

Many commenters expressed concern over the possible lack of correlation

between levels of indicators and the controlled toxic pollutants. The commenters noted that certain indicators may be present in concentrations several orders of magnitude greater than the toxic pollutant. This comment was most imaginatively expressed by the Chemical Manufacturers Association, which stated: "To select an 'indicator' controlled to concentrations several orders of magnitude greater than the toxics indicated is almost like trying to determine the weight of a flea by weighing a dog with and without the flea." Still other commenters attempted to support their objections by submitting charts demonstrating the poor correlation between what they termed an indicator and a specific pollutant (e.g., total suspended solids and zinc) in their discharges.

EPA believes that the above commenters have misconstrued the "indicator" concept and regulation. EPA does not assert that indicators and specific toxic pollutants controlled through the indicator limits must be or are likely to be statistically correlated. Nor does it assert that any pollutant used as a measure of a class of compounds will necessarily be statistically correlated to each or any compound in that class. Rather, the function of an indicator limit is to assure the installation and maintenance of BAT controls for toxic pollutants. Sufficiently low limits on one or more indicators may require installation of treatment equipment known to constitute BAT for certain toxic pollutants. In that case (and only in that case), the indicator limits will have served their purpose of assuring BAT control of the toxic pollutants, whether or not a correlation exists between the indicators and toxics.

Two commenters urged the use of bioassays instead of indicators or to calibrate indicators. The use of bioassays is discussed below in sections III.D.2.d and III.E.2 of this preamble. It is noted here, however, that bioassays and indicators generally serve different purposes and are not generally substitutable for each other.

Some industrial commenters argued that if the indicator concentrations are not statistically correlated with the toxic concentrations, a violation of an indicator limit may occur even when the indicated toxics are not being discharged at significant levels. EPA does not expect this to be a problem. Indicators will be used only where necessary to control discharges of toxic pollutants. If a toxic pollutant will not be discharged at levels above those

achievable by BAT, then an indicator limit will not be authorized by § 122.3(g).

If an indicator limit is violated by the permittee, this demonstrates improper operation or maintenance by the permittee of its treatment system. In such a situation, the violation may properly result in an enforcement action. Of course, a situation may arise where indicator limits are set to control toxic pollutants which are discharged above BAT levels at the time of permit application, but which are later no longer present at levels requiring control.

In that case, the permittee may apply for a permit modification to eliminate the indicator limit or to modify it to a less stringent level authorized by law.

Some environmental groups used similar logic to that used in the preceding comment by industrial commenters and argued that if indicator concentrations are not correlated with toxic pollutant concentrations, a significant discharge of toxic pollutants may not result in a violation of the indicator limit. EPA agrees, as it acknowledged in the June 14 preamble, that this is a possibility in some cases. However, the proper selection of indicators should assure that violation of the indicator limits will occur whenever the treatment system is not properly operated or maintained. When the system is properly operated or maintained, the indicated toxics should generally be reduced to levels below BAT. Furthermore, as noted above, the regulations allow the use of indicators only where the direct limitation of toxic pollutants is infeasible.

EPA also notes that occasional monitoring of specific toxic pollutants as required by the permitting authority would reveal whether an indicated toxic is being discharged at high levels. If so, the application-based notification requirements of § 122.61(a) would be triggered. The permitting authority could then, if necessary and feasible, modify the permit to limit the toxic directly. EPA has rejected the suggestion by one environmental commenter that EPA specify technology in conjunction with the use of indicators. Such an approach is inconsistent with the general statutory approach that, except for the specification of best management practices in certain instances (see § 122.62(k)), permits should specify effluent limitations rather than technologies or control practices.

Some commenters suggested that indicators be used only for monitoring purposes. EPA disagrees. Although direct limitation of toxic pollutants is required whenever feasible, indicators may be necessary as permit limits in

certain situations. However, indicators may be used for frequent monitoring purposes when toxics are limited directly. In such situations, the indicators would be monitored frequently, and the toxics would be monitored less frequently to reduce monitoring costs.

Some environmental commenters suggested that any violation of an indicator limit should trigger automatic monitoring of the indicated toxics, as was suggested in the preamble. Such monitoring will often be appropriate when indicator limits are violated. However, in many instances, the source of the violation may be discerned and corrected without such testing. Therefore, EPA has rejected this suggestion. The Director thus retains the flexibility to take the most appropriate approach to discover and remedy the cause of the violation. In addition, the final consolidated regulations (in § 122.62(g)) require permits to specify that violations of maximum daily discharge limitations on indicators, as well as limitations on toxic pollutants and hazardous substances, must be reported within 24 hours, so that the Director may take appropriate action.

One commenter noted that the statutory deadlines for an indicator and the indicated pollutants may differ in certain cases under section 301(b) of the Clean Water Act. When a parameter is used as an indicator, any earlier statutory deadline for the indicated pollutant controls.

Finally, some commenters argued that application-based limits (proposed § 122.68(a)) should not apply to indicated toxic pollutants. As explained in section III.B.1 of this preamble, EPA has deleted its proposed application-based limits from the final regulations. Thus, under the final rule, indicated toxics will not be subject to application-based limits. They will, however, be subject to the much less burdensome application-based notification requirements in § 122.61(a).

C. NPDES Application Requirements for Concentrated Animal Feeding Operations and Aquatic Animal Production Facilities: § 122.53(e) and Form 2b

The requirements for applications from concentrated animal feeding operations and aquatic animal production facilities appear in § 122.53(e) of the final regulations and in Form 2b. Although these requirements were inadvertently omitted from the proposed regulations, draft Form 2b was published in the June 14, 1979 Federal Register (44 FR 34393) and was the subject of several comments.

The State of Nebraska expressed approval of Form 2b and noted its similarity to the form used by their State. The American Farm Bureau had two suggestions which were adopted. First, the question on the location of the operation has been changed to require a detailed description of the location only if the answer to item VI of Form 1 was not sufficient. Second, the question about the number of acres available for manure disposal has been omitted; EPA agrees that it was not relevant to the NPDES program. The Department of Water Resources of Texas stated that the form was too technical and crowded, but suggested that questions should be added requiring a description of the method for disposing contaminated runoff, the water detention facilities, the pesticides used, and the plans for constructing a runoff control system. These suggestions have not been adopted, because the Agency has decided that the suggested additional information is not routinely needed to set appropriate permit limits for these facilities. Of course, Texas and other States may require this information on their application forms.

D. Minimum NPDES Application Requirements for Existing Industrial Dischargers: § 122.53(d) and Form 2c

1. General Discussion of Requirements; Public Availability of Information

On June 14, 1979, EPA proposed new application requirements and a new Form 2c to be used by existing industrial dischargers. Consistent with the Clean Water Act's mandate that EPA focus upon the control of toxic pollutants and with EPA's new permitting strategy for toxic pollutants in response to that mandate, EPA proposed that existing industrial dischargers be required to submit in their NPDES permit applications, in addition to other information, detailed information concerning discharges of toxic (and certain other) pollutants.

The requirements reflect the Agency's belief (which was supported by many commenters) that dischargers have a duty to be aware of any significant pollutant levels in their discharge. In addition, they serve two specific purposes. Most important, they provide the information which permit writers need to determine what pollutants are likely to be discharged in significant amounts and to set appropriate permit limits. Second, they will be used as a basis for application-based notification requirements under § 122.61(a).

The final regulations retain the essential components of the proposed application requirements of June 14,

1979. Some testing requirements were modified for certain industries based on EPA's continuing review of data on those industries' discharges. In addition, certain requirements were added with respect to hazardous substances designated under section 311 of CWA, based on EPA's August 29, 1979 proposal (44 FR 50780) responding to the 1978 Amendments to section 311(a)(2).

Dischargers will generally be required to submit applications in three situations: when an initial permit is needed, when an existing permit will soon expire and a new permit will thus be needed, and when a permit is being revoked and reissued under 40 CFR 122.15. However, § 124.5 provides that an application may also be required, if specifically requested by the permitting authority, when grounds for permit modification exist. This requirement was also contained in previous NPDES regulations in § 122.14(e) (44 FR 32905). A more extensive requirement in § 122.10(b), that new applications be submitted for certain types of modifications, has been deleted in response to comments pointing out that a new application is not always necessary in such situations.

The new application requirements and Form 2c apply only to existing dischargers. Until Form 2d is developed, EPA Forms 7550-8, -9 and -23 should continue to be used by new sources and new dischargers as well as by existing facilities which will first begin to discharge through particular outfalls in the future.

Applicants should note that section 402(j) of CWA requires that any information contained in a NPDES permit application must be made available to the public. (This rule set forth in 40 CFR 122.19 and is highlighted in the instructions to Form 2c.) Therefore, EPA has not accepted the suggestion by some commenters that certain portions of the application be confidential. However, EPA has attempted to address this potential concern by minimizing requests for information which may be regarded by certain applicants as sensitive.

First, information on the applicant's volume of production (or other measure of total operation) is requested only of applicants who are subject to production-based effluent limitation guidelines. Applicants subject only to concentration-based guidelines or to case-by-case development of individualized permit limits (when no guidelines apply), for example, need not submit such information. Second, all effluent discharge reporting requirements ask only for end-of-pipe effluent data, rather than in-process

waste stream data. While permit writers may request additional information not required in the EPA application form (under § 122.53(d)(13), discussed below in section III. D.3.i of this preamble), such information is subject to the protections afforded by 40 CFR Part 2.

Some industrial commenters argued that product information submitted by applicants subject to production-based guidelines should be held confidential. Some argued that if all application information must be available to the public, then product information should be deleted as an application requirement and obtained by permit writers on a case-by-case basis, such as under the authority of section 308 of CWA.

EPA must reject the above suggestion for several reasons. First, it is not administratively feasible to require permit writers to individually request many thousands of permit applicants to submit such information separately from the standard application process. While permit writers will in some instances need to request information in addition to that required in the application form, they cannot be expected to do so on a regular basis for routine information. This would result in unacceptable delays in issuing permits.

Second, much of the information in the permit application is "effluent data" within the meaning of 40 CFR 2.302(d)(2) and therefore would have to be disclosed under section 308 of CWA. For example, if the applicant is subject to an effluent limitations guideline of 7 pounds of BOD per 1000 pounds of product produced, a production figure is necessary to determine the amount of BOD discharge authorized by the applicable limitation. Even if the production figure could be protected from public disclosure, the figure could easily be calculated from the permit limitation.

Third and most important, EPA believes that the requested product information is not sensitive. Applicants are requested in the instructions to the form to report product information based on past production, such as highest month of the past year or the monthly average of the highest year of the past five years. (This reflects the requirements of 40 CFR 122.63(b).) The applicant need not identify in the application which basis was used to determine production volume. Moreover, the reported information does not indicate the applicant's estimate of future product demand or its anticipated future production.

The final application requirements include one new item which might be regarded as touching upon sensitive

data. Applicants are now required to list any toxic pollutants which they use or manufacture as intermediate or final products or byproducts. EPA has tried to minimize the possibility that reporting this information will result in revelation of trade secrets. First, applicants need not indicate on this list the specific basis for listing any particular pollutant; the basis will be assumed to be one of the above factors. Second, applicants need not list the amount used or manufactured.

Certain wording changes have been made in response to comments in other questions on Form 2c to minimize the amount of potentially sensitive information required. These changes are discussed in more detail in section III.D.3 of this preamble.

2. Required Analyses and Estimates of Pollutant Discharges

a. *Toxic Pollutants: § 122.53(d)(7)(iii) and item V-C.* The chief innovation of the new NPDES application requirements is that applicants must report discharges of toxic pollutants. The proposal required applicants in 36 industries (the 34 primary industries listed in the modified NRDC Settlement Agreement, plus the Asbestos and Ferroalloys industries) to test for all toxic pollutants (except for asbestos and TCDD, which are discussed below). The final regulations have modified this requirement for certain industries.

The reporting requirements for toxic pollutants may be summarized as follows:

(1) All applicants in the 34 primary industries listed in the NRDC Consent Decree must analyze their process wastewater outfalls and report quantitative results for the 13 metals on the toxic pollutant list and for cyanide and total phenols.

(2) All applicants in the 34 primary industries must analyze their process wastewater outfalls and report quantitative results for some or all of the 114 organic toxic pollutants. The organic toxic pollutants have been grouped into the four fractions which are used in the gas chromatography/mass spectrometry (GC/MS) analytical test method. The regulations and Form 2c each contain tables showing the fractions which applicants in each of the 34 industries must test for.

(3) All applicants must indicate the presence of any toxic pollutants which they know or have reason to believe are or will be discharged from any outfall. They are required to analyze only for those pollutants which they know or have reason to believe are currently discharged.

An exemption from the second and third requirements listed above is provided for small businesses whose average annual gross sales total less than \$100,000 (or, in the case of coal mines, those whose average annual production is less than 100,000 tons of coal). See section III.F.6.b of this preamble.

The proposed requirement that applicants in the 36 industries analyze for the 129 toxic pollutants was heavily commented upon. Environmental groups, many private citizens, and some State agencies expressed strong support for the analysis of the 129 toxic pollutants as a minimum requirement. (Many of these commenters argued, in fact, that the requirement is insufficient in itself and should be supplemented by biomonitoring requirements. See discussion in section III.D.2.d of this preamble.) On the other hand, many industrial commenters argued that the requirement was too broad, imposing significant costs to sample and analyze for pollutants which may be absent from applicants' waste streams. In particular, commenters from certain industries (pulp and paper, mining, oil and gas extraction, metal finishing, steam electric generating plants, textiles, rubber processing, and laundries) argued for full or partial exemptions for their industries or for all industries.

In the June 14 preamble, EPA stated in support of its proposed reporting requirements that although EPA has sampled plants in each industrial category as part of the effluent guidelines development process, plant-unique situations could be discovered only through waste stream analysis by each discharger. As described today in section III.B of this preamble, EPA needs to be aware of those specific situations to write adequate permits. The Agency restricted its proposed requirements to the 36 industries which EPA concluded were likely to discharge at least some toxic pollutants. The Agency noted, however, that it would continue to investigate existing data and would add or delete requirements to ensure that waste streams be analyzed only for pollutants which may be discharged.

In response to EPA's specific request for comments on this issue, several suggestions were received. The comments and ERA's responses are set forth below:

1. *Comment:* EPA should require applicants to test only for the pollutants regulated in the relevant effluent limitations guidelines. *Response:* EPA has not adopted this approach because it ignores the diversity among plants which the application requirements are designed to address. It also would

require EPA to wait for guidelines to be finally promulgated before setting application requirements. That approach would delay the permitting process and possibly result in failures to meet the statutory 1984 deadline.

2. *Comment:* EPA should require applicants to test only for those toxic pollutants which they know or have reason to believe are present in their discharges. *Response:* EPA has not adopted this approach for primary industries because, as EPA has learned during its industry sampling efforts, it can be difficult to predict what toxic pollutants will be discharged from an outfall. However, this approach is being used for secondary industries and for primary industries' non-process wastewater outfalls, since their discharges are much less likely to be toxic.

3. *Comment:* EPA should leave the application requirements to be determined on a case-by-case basis by the Director or should allow the Director to waive requirements on a case-by-case basis. *Response:* EPA has not adopted either approach. EPA is required by section 304(j) of CWA to develop "uniform application forms and other minimum requirements." While this does not preclude EPA from making valid distinctions among industries with differing discharges, EPA should not burden permit writers with the obligation of determining the pollutants which each particular applicant must test for. Indeed, as noted in the preceding paragraph, it would be difficult for permit writers and applicants to determine whether certain toxic pollutants will be discharged by the applicant without testing the discharge. Furthermore, allowing application requirements to be established on a case-by-case basis would result in unfairly disparate application requirements for similar applicants. (Note that EPA does not bar permit writers from requesting further information where appropriate for a particular discharge. However, the minimum requirements should be uniform as required by law.)

4. *Comment:* EPA should allow the substitution of biomonitoring for chemical monitoring. *Response:* Although biomonitoring provides information on the toxicity of a discharge, it does not identify particular pollutants which may be causing the toxicity (certain biological methods of identifying specific chemicals are in the development stage, however). To control the toxicity, it is important to identify and address the sources of that toxicity. Thus biomonitoring is not a suitable

replacement for chemical monitoring, although it may be a useful supplement in certain situations (see discussion in section III.D.2.d and III.E.2 of this preamble).

5. *Comment:* Toxic pollutants in certain effluents may be better controlled through Best Management Practices programs; thus testing is not necessary. *Response:* Regardless of the appropriate method of control, one first needs to identify the toxic pollutants being discharged and the means of the discharge. Furthermore, Best Management Practices will be used to regulate process wastewater discharges through outfalls only in relatively few circumstances (see § 122.62(k)); end-of-pipe BAT controls generally will be used for such discharges.

6. *Comment:* Applicants should be required to test only for those pollutants detected or likely to be detected at significant levels, based on data available to EPA, such as from its industry sampling efforts. *Response:* While EPA has not selected precisely this approach, the final regulation (described immediately below) takes a similar approach and imposes similar costs.

EPA has decided to use different approaches for the metals and the organic chemicals on the toxic pollutant list.

All applicants in the primary industries (the 34 NRDC Consent Decree industries) must test their process wastewater discharges for all the toxic metals, because almost all primary industry applicants discharge some metals and because the incremental cost of testing for all 13 toxic metals over the cost of testing for a few metals is relatively small. On December 3, 1979 (44 FR 69464), EPA proposed a new method for testing metals in addition to those already promulgated in 40 CFR Part 136. The method is ICP (inductively coupled plasma optical emission spectroscopy), which provides a simultaneous determination of several metals in a sample. When this method is promulgated, it may make the cost of testing for all 13 toxic metals comparable to testing for fewer metals using other methods.

All applicants in primary industries must also test their process wastewater discharges for cyanide and total phenol. The proposed requirement that all applicants test all discharges for these pollutants has been deleted, as several commenters suggested, because they are not likely to be found in most discharges other than primary industry process wastewater discharges. However, applicants must test for them whenever they expect them to be discharged.

"Process wastewater" is defined in the Glossary of the instructions to the consolidated application forms. In cases of uncertainty in applying the definition, applicants should contact their permitting authorities.

EPA has modified its proposed requirements for organic toxic pollutants by exempting certain industries from testing for certain pollutants. The approach used by EPA applies two factors. First, as suggested in the sixth comment listed above, is the likelihood that an applicant may discharge a particular pollutant. Second is the extent to which deletion of a toxic pollutant or group of toxic pollutants from the list of reportable pollutants results in cost savings.

EPA has determined the likelihood of discharge by using an approach suggested by many commenters. EPA decided that any pollutant which has been detected at greater than 10 µg/l (different cutoffs are used for several pesticides) in one or more samples in an industry should be tested for by all applicants in the industry. This approach has been selected because, in most industries, EPA has sampled only a small percentage of the plants. Thus the appearance of a pollutant in the data base for an industry implies that it may be discharged by several plants in that industry.

In analyzing the costs of various levels of testing requirements, EPA considered both sampling and analytical costs. (Detailed derivations of costs assumed in this discussion are contained below in section III.F of this preamble.) Sampling costs for one outfall (\$1,550) are not affected by the number of pollutants analyzed. Thus, the cost of collecting a sample to analyze for all 114 organic toxic pollutants is equivalent to the cost of sampling for only a few of them. Analytical costs, however, are somewhat dependent on the number of pollutants analyzed. Using gas chromatography/mass spectrometry (GC/MS), pollutants are grouped into four fractions which are based upon similar chemical and physical properties. Within a fraction, virtually identical analytical costs are incurred whether one pollutant or all pollutants in a fraction are tested. Moreover, since pollutants in the same fraction share similar chemical and physical properties, the presence of a pollutant in a discharge indicates some likelihood that other pollutants in the fraction may also be discharged. However, elimination of entire fractions from testing requirements can reduce costs. Thus, assuming that testing for all four

fractions may cost \$2,000, deletion of one fraction may save \$150 to \$500, depending on the fraction deleted.

Based on the reasoning outlined above, EPA has decided to require applicants in each primary industry to test process wastewater for any pollutant which has been found in discharges from plants in that industry, plus any other pollutants which are contained in the same GC/MS fraction as that pollutant (since this additional analysis is virtually costless and may yield further information of significance). (Applicants with sales of less than \$100,000 per year, or production of less than 100,000 tons per year in the case of coal mines, are exempt from testing for organic toxic pollutants under § 122.53(d)(8). See the discussion in section III.F.6 below.) When no pollutants of a particular fraction have been detected in any sampled plant in an industry, that fraction has been deleted as a requirement for applicants in that industry.

After formulating the rule for testing requirements as outlined above, the Agency reviewed the data which has been generated in its effluent guidelines sampling efforts to determine which pollutants have been found in each of the 34 primary industries. The Agency recognizes the technical problems in its approach. Most important, EPA's data base, the most comprehensive data base available, is to some extent subject to errors in sampling, analysis and reporting. On one hand, there is some possibility that a pollutant shown by the data to have been found in a plant's discharge was not actually present. On the other hand, it is possible that a pollutant which was present in a discharge will be shown in the data to be absent. Another problem is that there is limited data for certain categories and especially for subcategories.

Given the shortcomings in the Agency's data base, it became necessary to decide whether to base testing requirements for a GC/MS fraction on a single detection of a pollutant in the fraction, a greater number of detections, or upon some minimum ratio of detections to samples. The Agency decided to adopt the approach of one detection at concentrations above 10 µg/l. First, this approach is less arbitrary than the alternatives, which would have required a judgment without any technical basis that some other number correctly represents the degree of error in the data base. The selection of a single detection as a criterion acknowledges the difficulty of making such a judgment and

relies rather on the assumption that a detection indicates a reasonable likelihood of actual presence of a toxic pollutant in a discharge.

Second, as noted above, the cost savings of deleting a particular fraction from the testing requirements for a particular industry are only a small part of the remaining sampling and analysis costs. Therefore, it is appropriate to require testing of a fraction whenever a reasonable likelihood exists that a pollutant in the fraction is being discharged.

Third, the adopted approach is the most environmentally protective alternative to EPA's proposed approach: requiring testing for all four fractions without exception. Any further relaxation of the proposal would result in a higher probability that some plants would not be required to test for certain toxic pollutants which they discharge.

The need for stringent testing requirements is particularly strong in light of the Agency's decision not to require biomonitoring for toxic effects on a uniform basis. As noted elsewhere in the preamble, many private citizens as well as environmental groups have urged that EPA require biomonitoring. EPA's chief argument for not requiring biomonitoring at this time is that it is more appropriate to focus the testing requirements at this stage upon monitoring of specific toxic pollutants. This argument would be weakened substantially by a further relaxation of the toxic pollutant testing requirements.

The final toxic pollutant testing requirements for primary industries strike a reasonable balance between the competing considerations of cost and environmental protection by exempting industries from testing those GC/MS fractions in which toxic pollutants have not been found. This criterion has resulted in the exemption of 16 out of the 34 primary industries from testing for the pollutants in the pesticide fraction. In addition, 3 industries are exempted from testing for pollutants in the acid fraction, 1 industry is exempted from testing for the pollutants in the volatile fraction, and 1 industry is exempted from testing for pollutants in the base/neutral fraction. See Part 122, Appendix D, Table I, and Table 2c-2 of the instructions to Form 2c.

EPA has deleted the proposed requirement that applicants in the Ferroalloys and Asbestos Manufacturing industries test for all toxic pollutants. EPA's industry toxic pollutant sampling efforts covered only the primary industries. EPA thus lacks the data to support a supposition that secondary industries are discharging toxic pollutants. Thus secondary industries,

including the Ferroalloys and Asbestos industries, are exempted from mandatory testing for toxic pollutants.

However, in addition to the testing requirements specified for process wastewater discharges from primary industries, all applicants are required to report discharges of any toxic pollutant which they know or have reason to believe may be discharged through any outfall. This requirement includes pollutants in GC/MS fractions not marked in Table 2c-2 of the instruction to Form 2c, pollutants discharged by primary industries through nonprocess wastewater outfalls, and pollutants discharged by secondary industries through any outfall. This requirement is similar to the proposal, with one change. The proposal allowed applicants to estimate such discharges. The final regulation allows estimation of presence or absence; however, applicants are now required to test for any pollutant known or believed to be present in the discharge.

EPA has decided to require testing for one toxic pollutant for which the proposal allowed estimates: TCDD (2,3,7,8-Tetrachlorodibenzo-p-dioxin). Testing for TCDD was excluded from the proposal because the routine shipping and use of analytical standards of TCDD needed to perform quantitative analyses would endanger the public due to the extreme toxicity of TCDD. The National Wildlife Foundation correctly noted that due to TCDD's toxicity, "added rather than lessened precautions must be taken to avoid its undetected discharge into the environment." Accordingly, EPA will require certain dischargers to screen for TCDD in a manner which does not require the shipping of analytical standards.

Applicants who produce or use the following compounds must screen for TCDD:

- 2,4,5-trichlorophenoxy acetic acid (2,4,5-T)
- 2-(2,4,5-trichlorophenoxy) propanoic acid (Silvex, 2,4,5-TP)
- 2-(2,4,5-trichlorophenoxy) ethyl 2,2-dichloropropionate (Erbon)
- O,O-dimethyl O-(2,4,5-trichlorophenyl) phosphorothionate (Ronnel)
- Hexachlorophene (HCP)
- 2,4,5-Trichlorophenol (TCP)

This list is based upon a recent draft study conducted by EPA's Office of Toxic Substances: *Dioxins: Sources, Transport, Exposure and Control* (April 1979). These studies indicate that TCDD is likely to be a contaminant in the six compounds listed above.

TCDD screening will be done by the use of GC with an electron capture detector. This method will reveal the

presence of dioxin but will not separate its isomers. However, positive results may then be used by the permit writer as a basis for requiring the use of GC/MS and a TCDD standard to identify and quantify TCDD (see method 613, proposed in 40 CFR 136 on December 3, 1979, 44 FR at 69526).

EPA is retaining the proposed exemption from testing for one other toxic pollutant: asbestos. Due to the lack of a suitable test method for asbestos, applicants are required only to indicate whether asbestos is expected to be discharged and, if so, to describe the source of the discharge and to submit any available analytical data.

Applicants whose outfalls were analyzed by EPA during EPA's industry sampling program may submit quantitative data generated by EPA rather than retest their discharges, if the data is less than three years old and remains representative of the present discharge. When data has not been developed by EPA for a particular pollutant, the exemption does not apply to that pollutant. The exemption should affect at least 100 applicants. The June 14 proposal required data to be no more than two years old; commenters pointed out that more than two years will generally have elapsed since EPA tested the applicant's effluent. In response, EPA has changed the time to three years. (This period is consistent with regulations requiring permittees to retain monitoring records for three years.)

For the applicants who are required to test their waste streams, EPA has reduced its sampling requirements from the proposed 72-hour single flow proportional composite sample to a 24-hour sample. This change was adopted in response to comments and after reconsideration of the relative costs and benefits of using 24-hour samples and 72-hour samples.

The Agency has used 24-, 48-, and 72-hour samples in its data collection efforts. Although a 72-hour sample may in some instances be more representative of a discharge than a 24-hour sample, other factors such as the retention times of treatment facilities would have to be considered in each instance to determine the most appropriate sampling time. Furthermore, preserving a 72-hour sample may introduce errors which cancel the benefits of the longer time period.

Although the incremental benefits of using a 72-hour sample instead of a 24-hour sample are questionable, the cost savings of using a 24-hour sample are substantial. The cost of sampling a single outfall for 72 hours is estimated to be \$2,500, while the cost for 24 hours is

\$1,550; thus a 24-hour sample results in a savings of \$1,000 per outfall. EPA cannot conclude that the benefits of using a 72-hour sample justify the costs.

Several commenters objected to the lack of standard EPA-approved sampling methods. However, as discussed in the June 14, 1979 preamble, the art of sampling is dependent on experience and often not amenable to standardization of methods.

Accordingly, only general guidance on sampling is given in the instructions to Form 2c. Sampling should be supervised by an experienced contractor, as assumed by EPA in its sampling cost estimates (section III.F.1 below). (Certain sampling issues are discussed later in this section of the preamble.)

Many comments were received concerning the lack of promulgated methods for the analysis of the organic toxic pollutants. EPA proposed methods for analysis of the organic toxic pollutants on December 3, 1979 (44 FR 69464). The comment period on the methods, which include GC, HPLC, and GC/MS, was extended to April 28, 1980. (See 45 FR 15950, March 12, 1980.) Comments on the adequacy of the test methods will be considered in that rulemaking proceeding and will not be addressed here, except to note that the elimination of proposed application-based limit requirements has reduced the importance of high precision and accuracy in data reported in NPDES applications.

Because the comment period for the test methods for organic toxic pollutants was extended, the methods may not be promulgated in 40 CFR Part 136 by the time that some applicants test their waste streams. As a result, EPA will allow applicants to use any suitable method to test for any pollutant for which Part 136 methods do not exist. To assure quality control, applicants will be required in such cases to describe the method used, including sample preservation techniques. When an independent laboratory conducts the analysis, the applicant should request this information so that it may be included in the application. Applicants are encouraged (but not required) to use the December 3, 1979 proposed methods for organic toxic pollutants until the final methods are promulgated in Part 136.

b. *Other Pollutants.* In addition to the toxic pollutants, all applicants will be required to report other pollutants in all types of discharges. Some of these pollutants are conventional and nonconventional (pollutants not listed as toxic under section 307(a) or conventional under section 304(b)) pollutants which have traditionally been

of concern in the NPDES program, and others are nonconventional pollutants which have not generally been regulated before, such as certain hazardous substances. Fewer commenters addressed these requirements than the requirements for testing of toxic pollutants, perhaps because of the relatively smaller costs.

There are three groups of pollutants, other than toxic pollutants, with differing reporting requirements:

(1) All applicants must test all their discharges for the first group of pollutants.

(2) All applicants must indicate whether they know or have reason to believe that any of a second group of pollutants is present in any discharge. They must then test for any of those pollutants known or believed to be discharged.

(3) All applicants must indicate whether they know or have reason to believe that any of a third group of pollutants is present in any discharge. They must then describe the source of any pollutant known or believed to be discharged and provide any analytical data which they possess.

These requirements are discussed immediately below.

(i) *Required Analyses: § 122.53(d)(7)(i) and item V-A.* All applicants must analyze for three conventional pollutants (BOD, TSS, AND pH) and four nonconventional pollutants (temperature, COD, TOC, and ammonia).

Certain minor revisions have been made from the proposed requirements.

First, the toxic pollutants cyanide and total phenols have been moved from this list to item V-C. Thus applicants other than primary industries, which must test their process wastewater outfalls, are not required to test for cyanide and total phenols unless they expect them to be present. This change, advocated by several commenters, was made because these two pollutants are less likely to be discharged by secondary industries or from non-process wastewater outfalls than the other parameters in item V-A.

Second, the required measure of nitrogen compounds in item V-A has been changed from total Kjeldahl nitrogen (TKN) to ammonia. Ammonia is the nitrogen compound of most concern in terms of water quality. EPA has recently proposed to add ammonia to the section 307(a) list of toxic pollutants (45 FR 803, January 9, 1980). Total organic nitrogen, which measures nitrogen compounds, which are generally nutrients, is now required in item V-B. (Total Kjeldahl nitrogen is the sum of ammonia nitrogen and total organic nitrogen.)

Some commenters requested deletion or selected waiver of the uniform testing requirements, the development of industry-specific requirements, or the addition of pollutants (total oxygen demand and total organic halogen). EPA believes that the requirements of item V-A are generally appropriate for two reasons. First, the parameters in item V-A are commonly found in many different types of discharges. Second, taken together they are generally indicative of the nature of a discharge. In addition, the testing costs are small. However, in response to comments, the regulations have been modified to provide that the Director may waive testing requirements, on a case-by-case basis, for one or more pollutants in item V-A. This selected waiver is reasonable in light of the substantial experience which permit writers have in regulating the parameters included in item V-A.

(ii) *Required Reporting of Presence or Absence and, if Present, Required Analysis: § 122.53(d)(7)(iii) and item V-B.*

All applicants must indicate expected presence or absence of discharges of 2 conventional pollutants (fecal coliform and oil and grease) and 23 nonconventional pollutants and report at least one analysis for each pollutant expected present. These pollutants either are of less significance or are less likely to be found than toxic pollutants or the pollutants in item V-A, for which testing is automatically required.

Commenters on the proposal made many of the same general criticisms and suggestions as on item V-A. EPA has not made changes in response to these general comments (although some specific comments were adopted, as discussed below), particularly because the required level of reporting presents minimal burdens; actual testing is required only where the applicant knows or has reason to believe that it is discharging a pollutant. Furthermore, testing costs are relatively inexpensive. As noted earlier in this preamble, permit writers need to know what pollutants are present in an effluent to determine appropriate permit limits in the absence of applicable effluent guidelines. Therefore, EPA does not feel it is appropriate to make the requirements of item V-B any less stringent.

One significant change has been made from the proposal, which allowed applicants to estimate the levels of pollutants known or believed to be discharged. The final regulations and item V-B require applicants to test for all such pollutants. This change was made because EPA felt that the increased reliability of a test over an estimate justifies the increased cost in

those cases where one or more of these pollutants is expected to be discharged. The change also responds to industry comments pointing out that providing a quantitative estimate is technically difficult and to one comment suggesting that EPA require analysis of expected pollutants.

Other changes have been made in response to suggestions by commenters. The pesticides required to be reported in proposed item V-C are now listed specifically in item V-D (discussed below). Radioactivity has been subdivided into alpha, beta, radium and radium 226. Nitrate and nitrite have been combined as a single pollutant, in accordance with the usual practice of measuring their sum. Finally, the form's instructions and the regulations specify that applicants need not test for pollutants expected to be present solely as a result of their presence in intake water, but need only indicate that they are expected to be present.

EPA rejected certain other suggestions. EPA has retained the use of total residual chlorine (rather than the suggested free available chlorine) because it measures both free available chlorine and chlorinated amines, because most existing toxicity data is in terms of residual chlorine, and because EPA expects to use total residual chlorine as a pollutant measure in forthcoming new effluent guidelines for the Steam Electric Power Generating Industry. Aluminum has been retained, despite one commenter's argument that aluminum has low toxicity and solubility, because aluminum remains of sufficient concern to require limitations in some cases (see, e.g., 40 CFR 421.32 and 404.32).

(iii) *Required Reporting of Presence or Absence of Asbestos and Hazardous Substances: § 122.53(d)(7)(iv) and item V-D.* All applicants must indicate expected presence or absence, and briefly describe the source (or levels, if data is available) if present, of discharges of pollutants listed in item V-D. These pollutants include one toxic pollutant (asbestos) and 79 nonconventional pollutants which have been designated as hazardous substances under section 311 of the Clean Water Act but not listed as toxic pollutants and reportable in item V-C and which retain their undissociated form in water.

The proposed requirement for asbestos was controversial and has been changed. Applicants must now state briefly the source of any discharge of asbestos instead of testing or estimating the level of discharge. However, if they have analytical data

on any such discharges, applicants must report them.

Proposed item V-C required applicants to estimate or test for certain pesticides for which EPA had developed (interim) test methods. In response to comments, EPA has now listed specifically (in item V-D) each pesticide required to be reported: EPA has decided to list only those pesticides which have been designated as hazardous substances. These pesticides are contained in the list of 79 hazardous substances required by item V-D. EPA feels that focusing attention on pesticides formally recognized as hazardous in water is a realistic approach at this time.

Reporting requirements for the hazardous substances (other than those also listed as toxic pollutants) evolved out of 1978 Amendments to the Clean Water Act, which changed the relationship between the NPDES program and section 311 of CWA. Proposed § 122.64(d)(19) and item IX of the draft application form provided to permit applicants the option of submitting information on discharges of hazardous substances designated under section 311 of CWA to obtain exclusion of those discharges from the various requirements of section 311. The proposal reflected proposed 40 CFR 117.12 (44 FR 10271, February 16, 1979) in which EPA tentatively interpreted the 1978 amendments to section 311(a)(2) to grant exclusions for continuous or intermittent discharges which are caused by events occurring within the scope of relevant operating or treatment systems only if certain information identifying those discharges is submitted to the permitting authority. In the final regulations (40 CFR 117.12, 44 FR 50766, August 29, 1979), EPA revised § 117.12 to acknowledge that such discharges by permittees or permit applicants are exempt from section 311 even when information on the discharges is not submitted to the NPDES permitting authority.

Concurrently with promulgating 40 CFR 117.12 on August 29, 1979, EPA published a notice (44 FR 50780) modifying the June 14 proposed application requirements by adding a requirement concerning the reporting of certain discharges of hazardous substances in NPDES applications. This action was taken in recognition of Congressional intent that continuous or anticipated intermittent discharges of hazardous substances are appropriately regulated under the NPDES program rather than under section 311. The new proposal required reporting of 73 hazardous substances (in addition to the

June 14 proposal's requirement that hazardous substances which are on the section 307(a) toxic pollutant list must be reported) and of seven dissociation products of hazardous substances. The proposal required each applicant to report any of these pollutants which it knows or has reason to believe it is discharging. In addition, all applicants in 36 industries were required to test for vanadium.

Estimates were permitted except for 16 substances (13 pesticides, 2 chlorinated hydrocarbons and vanadium) for which official EPA test methods had already been developed; actual testing was required for these if expected present.

Commenters generally supported the approach of requiring reporting of a hazardous substance discharge only where the applicant knows or has reason to believe it is discharging the substance. This is a less stringent approach than used for toxic pollutants for several reasons. First, toxic pollutants are required to receive the closest possible scrutiny in the NPDES program under the 1977 Amendments to CWA; thus they may reasonably be distinguished from hazardous substances in formulating application requirements at this time. Second, test methods are lacking for most of the hazardous substances listed in the August 29 proposal. Third, most of the hazardous substances for which interim test methods exist are highly unlikely to be discharged except by a few industries (most notably, the Pesticides industry). Thus a more relaxed uniform reporting requirement for hazardous substances makes sense.

Several commenters contended that the test methods for 14 of the 16 hazardous substances for which EPA claims to have published test methods have not been properly promulgated in 40 CFR 136 under section 304 of CWA and that EPA is therefore barred from requiring any such analysis. They argued that the published methods had not been properly incorporated by reference in Part 136. EPA believes it has legal authority to require testing for those substances, whether by use of the Part 136 methods or by allowing applicants to choose any appropriate method. However, commenters further argued that the methods for pesticides have been less widely tested than the methods for toxic pollutants. EPA agrees with those commenters:

In response to the above comments, the proposed requirements have been modified. Applicants are now required only to indicate the source of the discharges for all hazardous substances unless they have analytical data. Of

course, as always, the permit writer may require further testing if necessary. EPA feels this more individualized approach makes sense at this stage of the NPDES program, since less is known about the analysis and treatability of many of these pollutants in discharges than is known for other pollutants to be regulated in the next round of permit issuance.

In response to EPA's request for comments on the list of hazardous substances for which application reporting was proposed, one commenter suggested that vanadium and uranium be omitted, and one commenter suggested that dicamba (a pesticide) be omitted. EPA was not persuaded by these comments. All of these pollutants have been designated by EPA as hazardous substances, which are designated to a large extent on the basis of toxicity criteria. Certain hazardous substances, such as acetic acid, are omitted from reporting requirements because they are toxic only in cases of spills causing shock effects; they are not toxic at the concentrations generally found in continuous discharges. However, vanadium, uranium and dicamba are of sufficient concern in continuous discharges to require reporting. The burden of such reporting is minimal, since the reporting is based on the inexpensive estimation of presence or absence rather than on more expensive testing.

c. General Concerns in Sampling, Analysis and Reporting of Testing Results. Several additional aspects of the sampling of waste streams and the reporting of analytical results were of concern to commenters and are discussed below.

(i) *Sampling Requirements.* The instructions to item V of Form 2c include some general requirements about when samples should be collected. (Not all aspects of these instructions are set forth in the regulations.) The proposed instructions included the statement that samples should be representative of the previous twelve months of operation. Several commenters pointed out that this requirement was incompatible with the minimum requirement of testing one sample. Based on the comments, this statement has been deleted from the final instructions. The instructions retain the statement that applicants should choose sampling times which are representative of their normal operations. If operations are so variable that no representative time can be selected, as claimed by a few commenters, applicants may describe in item VI of Form 2c any types of discharges which differ from those

tested (see section III.D.3.e of this preamble).

Two commenters objected to the requirement that all composite samples be flow-proportional and suggested that time-proportional samples be allowed when retention times are long enough. This suggestion has not been adopted because flow proportional samples give a more accurate measurement of the total mass discharged when flows are not constant. When flows are constant, there is no difference between flow-proportional and time-proportional samples. One of these commenters also requested clarification of the definitions of grab and composite samples; this has been done.

Several commenters pointed out that the proposed requirement that all samples be preserved by cooling to 4° Celsius was unnecessary for some pollutants, particularly metals. This requirement has been deleted from the instructions, but applicants must comply with specific requirements for individual pollutants covering sampling containers, holding times, and preservation procedures when they are promulgated (proposed at 44 FR 69464, December 3, 1979). Until these requirements are promulgated, applicants must describe the holding times and preservation procedures which they use.

(ii) *Reporting of Testing Results.*

(A) *Detection Limits.* The proposal required applicants to report detection limits for all pollutants in draft item V-C found to be not present. This requirement has been deleted because the proposed application-based limits have been deleted and the promulgated application-based notification requirements of 122.61(a) are not based upon multiples of detection limits. Therefore, the comments which were received on reporting of detection limits are no longer relevant, and the table in the proposed instructions setting forth detection limits has been deleted.

(B) *Miscellaneous Issues.* One commenter pointed out that reporting of flow was required in both draft items V-A and V-B. The purpose was to have the applicant report the flow once to correspond to the concentration levels reported for the toxic pollutants, and a second time to indicate the average and maximum flow over the course of one year. Flow is now reported only once because of reorganization of the form, as described in the next paragraph.

EPA has adopted certain suggestions by environmental groups advocating more detailed presentation of analytical results. Both concentration and mass of pollutant loadings must be reported in the application. In addition, pollutant

loadings must now be reported as maximum daily value and as maximum 30-day value and long-term average value, if available. This change does not require any additional testing but does require additional calculations.

"Maximum daily value", "maximum 30-day value" and "long-term average value" are explained in the instructions to Form 2c. Requirements for types of samples (grab or composite) are now specified in the instructions; therefore, they no longer have to be specified in item V of the form.

The application form does not require applicants to analyze intake water, but they may do so if they wish to be eligible for net limitations under § 122.63(h).

In response to a comment, a provision has been added to the final regulation allowing the Director to limit testing of substantially identical outfalls to a single outfall. The applicant must state in the application which outfalls were actually tested and which were not and explain why the outfalls are considered substantially identical.

Pollutants required to be reported in item V are listed on separate sheets at the end of Form 2c, numbered V-1 to V-9. In order to provide applicants with some flexibility in reporting, the instructions state that applicants may submit some or all of the required information on separate sheets instead of filling out pages V-1 to V-9, if they provide all the required information in the same format (to allow EPA to computerize the data). For example, applicants (or laboratories conducting analyses for applicants) may program GC/MS data systems to print the data in the required format, eliminating the need to copy the information onto a form.

d. *Response to Comments Advocating Biological Monitoring for NPDES Permit Applications.* The final regulations, like the proposed regulations, do not require biomonitoring of effluents as part of the application process. However, as discussed in the preamble to the proposal at 44 FR 34400, the permitting authority is encouraged to require toxicity testing when the information is needed to assess the toxicity of a present discharge. Toxicity information may be necessary, for example, (1) when BAT is basically equivalent to BPT (that is, no treatment beyond BPT is necessary to control 307(a) toxic pollutants); (2) when guidelines for BAT are absent and permit limits will be case-by-case; or (3) when pollutants will not be chemically analyzed (e.g., secondary industries or non-process wastewater) but toxicity is suspected. The results of such tests would then

allow the permit writer to decide whether to require a process evaluation to determine whether additional treatment is required. The option of using toxicity tests also provides the permitting authority with the flexibility to respond to specialized cases when the source of toxicity is something other than the listed toxic pollutants. Permitting authorities have the authority to require acute biological toxicity testing when toxic conditions have occurred in the past, when toxicity information is needed for establishing priorities for permit issuance, or when reported effluent data is insufficient. This authority is clearly provided in section 308 of CWA, which lists biological monitoring as an available method for the purpose of developing permit limitations.

A significant number of comments were received, particularly from private citizens and public interest groups, strongly supporting toxicity testing as a mandatory permit application requirement. At a minimum, most of these commenters wanted all Group I industries (defined in the proposal as the primary industries plus the Ferroalloys and Asbestos Manufacturing categories) to perform a two-tiered testing program consisting of: (1) a 96-hour, acute, static LC50 toxicity test on several appropriate species; and (2) persistency testing by sediment uptake of priority pollutants or bioaccumulation test of animal tissues. Commenters argued that such a testing program would not be an overly-restrictive burden on Group I industries. EPA disagrees and feels that these suggested requirements are inappropriate at this time. Toxicity testing is not being required of all applicants because, in many cases, additional or modified treatment will be required by BAT limits for specific pollutants. In these situations, the results of toxicity testing may not be relevant because specific pollutants which are sources of possible toxicity will be identified chemically and permittees will be required to reduce the concentration of these pollutants. When specific toxic pollutants are identified in the permit application, it may be assumed that the effluent has acute or chronic toxicity, which would make biomonitoring duplicative. EPA believes, therefore, that biomonitoring currently should be required on a case-by-case basis by the permitting authority in situations such as those identified above, where the information is needed to make a permitting decision. However, after installation of BAT treatment,

blomonitoring will play an increasingly important role in the NPDES program.

Several commenters argued that EPA cannot require biomonitoring for pollutants other than those regulated by a discharger's NPDES permit, apparently misunderstanding that biomonitoring does not test for specific pollutants. One of the advantages of biomonitoring is that total toxicity is measure regardless of the interactions of the constituents contributing to that toxicity. Therefore, toxicity tests measure the effects of chemical mixtures which cannot otherwise be limited in a permit.

One commenter argued that the Agency, not the regulated industry, should bear the burden of data gathering unrelated to determining permit compliance. EPA disagrees. Section 308 of CWA requires the discharger, not the permitting authority, to provide any information necessary to determine permit limits.

Some commenters argued that the cost of toxicity testing is prohibitive. Although testing for chronic toxicity and bioaccumulation can be expensive, the cost of acute toxicity testing is not prohibitive. Many industries have in-house testing capability and many companies have already generated toxicity information on their discharges. In addition, a substantial number of laboratories, including many environmental engineering firms, perform toxicity testing on a contract basis at competitive prices. The following table represents typical present-day costs of several types of acute toxicity tests:

Acute toxicity test	In-house	Contractor	
		Offsite	Onsite
24 hr Static,.....	\$100-200	\$200-500	\$2,000-3,000
96 hr Static	\$200-500	\$500-2,500	\$4,000-6,000
Renewal.			
96 hr Flowthrough.	\$300-600	\$800-2,500	\$6,000-10,000

Other commenters suggested that no biomonitoring be required until EPA publishes biomonitoring protocols. Several comments were directed at the lack of standardized test methods, particularly for chronic toxicity testing. Standardized test methods for acute toxicity testing are available (see *Methods for Measuring the Acute Toxicity of Effluents to Aquatic Organisms*, EPA-600/4-78-012) and EPA will soon propose formal rules under section 304(h) of CWA to include these acute toxicity test methods in 40 CFR Part 136. However, test methods for chronic toxicity and bioaccumulation are less standardized. In particular, tests used for the analysis of carcinogenic,

mutagenic, and teratogenic properties of pollutants are still undergoing development and evaluation. Therefore, test results on these measures should be carefully evaluated before they are used in the NPDES permit program.

Although biological toxicity testing will be used only on a case-by-case basis during the next round of permit issuance, EPA believes that biological testing must play a major role in future toxic pollutant control strategy. Therefore, EPA will propose rules in the near future to require all dischargers in selected subcategories to evaluate their effluents after BAT treatment processes are in operation using a standard biological screening protocol. The screening protocol will be relatively inexpensive and will identify effluents still containing significant toxicity. Further testing and preparation of a toxicity reduction plan may be required if screening reveals significantly toxic discharges. In cases where severe toxicity problems remain, the permit may be reopened and modified accordingly under § 122.15(a)(2). Data thus generated will also be used to assess problems associated with specific discharge types or chemical classes which could be involved in human health problems. The information will identify those instances where the magnitude of discharge would pose particularly hazardous and long term problems.

EPA expects that many post-BAT discharges will not have the acute toxicity problems which have been associated with industrial dischargers in the past. Of increasing importance in future pollution control will be problems involving chronic toxicity, persistence, and bioaccumulation. EPA plans to incorporate the developing technology in these area into future biomonitoring requirements.

3. Other Application Requirements

a. Outfall Location: § 122.53(d)(1) and Item I. A new requirement has been added that applicants list the latitude and longitude and the name of the receiving water for each outfall. Applicants should be able to generate this information easily from the map provided in Form 1. This information, suggested by environmental groups, will be useful to EPA and States in water quality studies and planning activities.

b. Flows, Sources of Pollution, and Treatment Technologies: § 122.53(d) (2)-(4) and Item II. The major change from the proposal is that, in response to comments, information required on a line drawing and in tabular form are better coordinated. The line drawing now must show average flows for all

types of wastewater, and item V-A requires reporting of the maximum daily total flow from each outfall (as well as average flows).

The information in item II is useful to the permit writer because it reveals what processes use or contribute pollutants to water in the facility, and what kinds of treatment wastewater currently receives. Therefore, comments suggesting that these requirements be deleted as unnecessary and burdensome have been rejected. EPA has also rejected the suggestion of environmental groups that all flows should be measured, not estimated. Estimated average flows are sufficient to give the permit writer a general picture of the facility's water use. However, when actual flow measurements already exist, they must be reported.

All sources of flow to an outfall must be identified in the line drawing, including cooling water, sanitary wastewater, and stormwater runoff. The instructions have been modified to emphasize that similar processes or operations may be shown on the line drawing as a single unit, labeled to correspond to the more detailed listing in item II-B. This responds to comments objecting that extensive reporting of flows between many individual processes would be burdensome.

The National Coal Association commented that the requirement to provide a line drawing is not appropriate for coal mines. In response, the question allows the applicant, when a water balance is not possible, to describe the source of the water (e.g., active surface mine, regraded area, or preparation plant) and its route before being discharged.

Average flows contributed by each operation to an outfall must now be reported in § 122.53(d)(3) and item II-B to enable the permit writer to determine the proportion of the total flow contributed by operations which are covered by an effluent guideline.

Identification of treatment systems is now requested in a coded form which will allow loading of this information into an automated data system. The appropriate codes are listed in the form's instructions.

The instructions have been modified in several other ways. First, processes and operations may be described in general terms, in response to commenters who feared that this requirement would reveal trade secrets. This general identification of processes contributing to wastewater effluent is necessary to identify the standards and limitations applicable to the discharge. Second, any reasonable measure of the flow contributed by stormwater, such as

duration or frequency of storm events, may be used. This responds to comments pointing out the difficulties of predicting flows resulting from rainfall. Finally, a description of the final disposal of any solid or liquid waste other than by discharge is required, so that the permit writer may determine the amount of the effluent discharged and identify the fate of all wastes.

Other suggestions made by commenters have not been adopted. One commenter suggested that estimates of future increased flows be allowed in calculating permit limits. However, the general policy of the NPDES program is to base present limits on present operation, rather than on potential increases. Another commenter stated that the question should not ask for the design flow of the treatment units, because the method of treatment may change. However, the description in the permit application is not binding, but simply must be representative of the facility at that time. Permittees may meet their permit limits by selecting any appropriate treatment equipment or methods.

The question requiring additional description of discharges which are intermittent or seasonal (§ 122.53(d)(4) and item II-C) has been modified slightly. Columns for outfall and contributing operation have been separated, and the column for volume of flow has been expanded to allow reporting of flow rate and duration if applicable.

c. Measure of Maximum Production: § 122.53(d)(5) and item III. Applicants must report maximum production when production-based guidelines apply to their discharges. This requirement has been changed slightly from the proposal. Applicants must now report only a maximum measure of their actual production, not an average measure as well. The instructions have been modified to give examples of guidelines expressed in terms of production or other measures of operation. They state that an applicant that discharges only non-process wastewater is not covered by a guideline and thus need not complete this item. Another modification is that applicants now must indicate which outfalls are affected.

d. Currently Required Construction, Upgrading or Operation of Waste Treatment Equipment: § 122.53(d)(6) and item IV. Applicants must report any current requirements for construction of waste treatment equipment. The proposed requirement to describe non-required projects proposed by the applicant is now optional.

One environmental group wanted item IV expanded to require listing all interim

dates in the construction schedule (as proposed § 122.64(d)(15) required). However, the Agency has decided that the application is not an appropriate mechanism to collect this information, which is usually publicly available anyway. The final compliance date is required to enable the permit writer to determine how soon the discharge will be affected or to decide whether to check other records for more information.

Item IV-B, which asks about planned projects, was made optional in response to several comments noting that the applicant's tentative project plans are an internal matter. Thus, applicants may report any projects they have in planning stages if they feel that this information will assist the permit writer in developing permit conditions; however, applicants are not required to reveal their plans.

e. Potential Discharges of Toxic Pollutants: § 122.53(d)(9)-(10) and item VI. Certain information on toxic pollutants must be reported in addition to the testing discussed above in section III.D.2 of this preamble. This additional information will help identify any toxic pollutants which may be discharged from the applicant's facility and thus should be controlled through permit limits. It will also be used as one basis for application-based notification requirements. (See section III.B.2.a.iii of this preamble.)

(i) Toxic Pollutants Used or Produced by the Applicant: § 122.53(d)(9) and item VI-A. Applicants must identify toxic pollutants which they use or manufacture as intermediate or final products or byproducts. This requirement supports § 122.62(e), which requires that permits be written to control toxic pollutants which are used or manufactured by the applicant. Several commenters noted that pollutants which are used or manufactured at a facility are likely to be discharged by the facility. In addition, several commenters (including an environmental group and State permit-issuing authorities) suggested that the application form include a requirement for an inventory of raw materials and products. This item responds to the above comments.

The Agency considered excluding from this application requirement those pollutants which are used or manufactured in small amounts. This approach requires a determination of cutoff levels of use or manufacture. However, because even relatively small amounts of a toxic pollutant can be of substantial concern in certain circumstances, the cutoff levels would have to be quite low. The Agency

concluded, therefore, not to use a cutoff but rather to uniformly require submission of information identifying any toxic pollutant used or manufactured by the applicant.

(ii) Predicted Potential Increases in Discharges of Pollutants: § 122.53(d)(10) and item VI-B and C. Applicants must describe and explain the causes of discharges of pollutants which may during the next five years exceed two times the maximum levels reported in waste stream analyses. This information will be used by permit writers to identify any pollutants which are expected to be discharged at significant levels and thus require control under § 125.3 (see section III.B.2.a.i of this preamble.) In addition, § 122.61(a) requires notification of future discharges at levels exceeding five times any levels reported in this question (see III.B.2.a.ii of this preamble.)

Items VI-B and C are essentially the same as the draft items VI-A, B, and C, except that the applicant is now required to report any discharges expected to exceed two times the maximum level reported in item V instead of five times the average level.

One commenter argued that since the Director may modify a permit if the discharge exceeds five times the reported level after the permit is issued, information on expected increases should be optional. This suggestion was rejected. It is appropriate to identify future discharges in the application and to set appropriate limits in the permit. This will help insure the installation of any equipment necessary to treat the potential discharges prior to commencement of the discharges. Reliance on future reporting and permit modification would result in delays in control and should be used only to control discharges which are not foreseeable at the time of permit issuance.

Some commenters contended that this question would be difficult or impossible to answer. However, the question requires only that predictable discharges or fluctuations be identified. When applicants have no reason to believe that such discharges or fluctuations will occur, they may answer "No" to item VI-B. If discharges or fluctuations are not predicted in item VI-B but later do occur, they will trigger application-based notification. When applicants believe that fluctuations may occur but cannot predict their degree, they should state their reasons for believing that the fluctuations may occur; the permit writer will then determine whether more information is necessary.

One commenter requested that some provision be made to exempt applicants from liability for false reporting if the estimates reported in item VI turn out later to be inaccurate. No such provision is necessary because applicants would not be liable to prosecution for incorrect estimates made in good faith.

f. Results of Previous Biomonitoring: § 122.53(d)(11) and item VII. Each applicant must indicate whether or not biological tests for acute or chronic toxicity have been performed on its discharge and describe the results of those tests. The proposed requirement that the test results be reported has been deleted.

Two commenters strongly opposed the requirement to report the results of previous biological toxicity testing because the data in many cases would have been developed by EPA in cooperation with the industries to assist in effluent guidelines development. Another commenter suggested that the proposed reporting requirement unfairly penalized industries who have been diligent in their cleanup efforts and would create serious legal or public relations problems for those dischargers who in the past have had effluent quality problems but have now installed extensive treatment facilities.

EPA agrees that requiring dischargers who have voluntarily conducted biomonitoring toxicity tests in the past to report the results could be unfair, particularly if their cleanup efforts have resulted in substantial toxicity reductions. The Agency has eliminated the requirement to provide the results of such testing on the application form. Instead, item VII requires applicants to report whether or not biological tests for acute or chronic toxicity have been performed on the discharge or on the receiving water in close proximity to the outfall. When the results of such tests are likely to indicate the present situation (e.g., when no new treatment system has been installed or when no production and process changes have occurred since the tests were conducted), the permit writer can review these factors and decide whether or not to request further information relating to those tests.

g. Laboratory Conducting Analyses: § 122.53(d)(12) and item VIII. If any of the analyses reported on the application form were performed by contract laboratory or consulting firm, applicants must identify each laboratory and the analyses which it performed. In the proposal, applicants were not required to identify which analyses were performed by which laboratories. This requirement was added in response to the single comment received on this

question. It imposes only a minimal reporting burden, while providing useful information for quickly following up on problems relating to the data.

h. Other Information Required by the Director on a Case-by-Case Basis: § 122.53(d)(13). In addition to complying with specific information requirements on the application form, the applicant must provide such other information as may reasonably be required to assess the discharges of the facility and to determine whether to issue an NPDES permit. This information may include additional quantitative data and bioassays to assess the relative toxicity of discharges to fish and other aquatic life, and requirements to determine the cause of such toxicity. This regulation is essentially the same as proposed § 122.64(d)(20), except for minor changes. The word "reasonably" has been added as suggested by one commenter. In addition, the sentence concerning bioassays, which appeared as a comment in the proposal, now has been incorporated into the regulation, with chemical analysis also mentioned explicitly.

Several commenters stated that permit writers were being given too much discretion to ask applicants to generate new and costly data, and that the regulation was too open ended and should be deleted. One commenter suggested that the specific informational requirements were so complete that this regulation was unnecessary. Another suggested that EPA develop a list of pollutants of concern by industry category, and limit requirements to that list. None of these suggestions was adopted, however, except for addition of the word "reasonably," which should provide protection against unreasonable requests for information. The need for "other information" on a case-by-case basis for certain discharges has been demonstrated by prior experience in the NPDES program. While the uniform requirements should suffice for most applicants, the flexibility to request further information in appropriate circumstances must be retained.

4. Proposed Application Requirements Deleted From the Final Regulations and Form

a. Optional Reporting Requirements for Hazardous Substances. Proposed § 122.64(d)(19) gave applicants the option of submitting information on discharges of hazardous substances designated under Section 311 of CWA to allow them to apply for exclusions of those discharges from the requirements and penalties of section 311. Item IX of the draft NPDES application form contained a format for submitting such

optional information to EPA. Both the regulation and item have been deleted from the final regulation and form.

EPA has deleted this question because it is unnecessary, in accordance with 40 CFR 117.12 (44 FR 50766, August 29, 1979) which states that to obtain exclusions from section 311, applicants need not report in their applications any information concerning continuous or anticipated intermittent discharges of hazardous substances which are caused by events occurring within the scope of relevant operating or treatment systems. (See section III.D.2.b.iii of this preamble for further background.)

Certain discharges by NPDES permittees or permit applicants, such as spills, remain subject to section 311 coverage absent the submission of appropriate information to the NPDES permitting authority and coverage in the NPDES permit. However, since this information may be submitted at an applicant's option under 40 CFR 117.12(a)(2) (dealing with "exclusion 2"), no regulatory requirement is needed in § 122.53(d). Furthermore, no single format will serve the purposes of each applicant seeking to exclude potential spills from section 311 coverage under exclusion 2. Instead, the instructions to Form 2c direct applicants seeking such exclusions to attach the information required by § 117.12(c)(1) to their application forms on additional sheets of paper.

Information on continuous or anticipated intermittent discharges of many hazardous substances is now routinely required of certain applicants by § 122.53(d)(7)(iv) and item V-D of Form 2c. These requirements reflect Congressional intent that such discharges be regulated under the NPDES program rather than under section 311 of CWA.

b. Submission of Data on Additional Pollutants. The proposed application form contained a question requiring applicants to report data on any pollutants in addition to those reported in item V (proposed § 122.64(d)(18) and draft item VIII). This requirement has been deleted from the final form. The deletion is in response to several comments objecting that the proposal was burdensome and required reporting of data that was inaccurate and not useful. The Agency agrees that the information would generally not be useful to permit writers in this round of permit issuances.

An environmental group suggested that EPA require applicants to submit or to keep on file any GC and GC/MS profiles they generate to provide information on additional pollutants. EPA considered establishing such a

requirement; however, investigation revealed several drawbacks. Only a computer-readable form of the raw data (that is, nine-track magnetic tape) would provide data on additional pollutants, and the cost of storing data in this form can be significant. The cost of reanalyzing the tapes ranges up to half of the cost of analyzing a new sample. Therefore, potential cost savings are not great and do not outweigh the advantages of conducting new sampling and analyses, when necessary, rather than retaining raw data on a routine basis. The retained data would be less current and would reveal only a limited number of additional pollutants.

c. Ancillary Activities Which may Result in Discharges of Toxic Pollutants or Hazardous Substances—Best Management Practices Programs. Proposed §§ 122.64(d) (11) and (13) and draft items III-B and III-C of Form 2c required each applicant to describe any actual or potential discharges of toxic pollutants or hazardous substances from ancillary activities and to attach a copy of its Best Management Practices (BMP) program for controlling these discharges. The requirement to develop a BMP program was contained in Part 125, Subpart K of the final NPDES regulations published on June 7, 1979 (44 FR 32854, 32954). The effective date of Part 125, Subpart K was deferred on August 10, 1979 (44 FR 47063) pending the availability of a BMP guidance document. On March 20, 1980 (45 FR 17997) the guidance document was made available for a 45-day public comment ending May 5, 1980 (see 45 FR 21635; April 2, 1980). Therefore, at this time 40 CFR Part 125, Subpart K is not yet effective.

In light of this timing problem, EPA decided to omit the requirement to submit a BMP program from Form 2c at this time. When Part 125, Subpart K becomes effective Form 2c will be amended as appropriate. This will allow EPA to make any adjustments to the requirements necessary to respond to public comments on the BMP manual as well as those previously submitted on proposed §§ 122.64(d) (11) and (13) and draft items III-B and III-C. In particular, EPA is considering comments submitted on the draft form which suggested that a summary of the BMP program, rather than the entire program, be included with the application, and that the description of actual and potential discharges (draft item III-B) be combined with this summary.

E. Monitoring Requirements

1. Chemical Monitoring

Specific monitoring requirements for an individual permittee are established by the permit writer when the permit is issued. § 122.11(b) requires that permits contain monitoring requirements which are sufficient to yield data representative of the monitored activity. However, it does not establish any specific requirements for monitoring type and frequency, but rather leaves that to the judgment of the permit writer. This case-by-case approach to setting monitoring requirements, which has been used in the past in the NPDES program, reflects the need to consider outfall-specific factors such as the flow rate, the types of pollutants discharge, the nature of the receiving water, and the existence of downstream intakes for drinking water.

Because monitoring requirements are related to many of the issues in the application form and permit regulations, the preamble to the proposed regulations contained (at 44 FR 34407; June 14, 1979) a description of a typical monitoring scheme under the new toxics-oriented permitting strategy. The scheme depicted the usual frequent monitoring for pollutants limited in the permit as well as periodic monitoring for some or all of the toxic pollutants and, in some cases, periodic biological monitoring. In addition, the proposed regulations included a provision (proposed § 122.71(a)(1)) allowing monitoring requirements to be set for pollutants controlled by the proposed application-based limits regulations, although, again, no frequency was specified. The preamble also discussed the costs which might be associated with particular compliance monitoring requirements.

Two major differences between the final regulations and the proposal affect monitoring requirements.

First, the proposal on application-based limits has been deleted, and the final regulations contain an application-based notification requirement and a provision authorizing permit modification when a toxic pollutant is discharged at a level exceeding that achievable by BAT. Although application-based limits might, as some commenters argued, have forced permittees to monitor their discharges frequently to ensure that the limits would not be violated and that the permittees would not be subject to enforcement actions, application-based notification requirements do not impose similar burdens. Notification is required only when the permittee knows or has reason to believe that some activity has

occurred or will occur which would result in increased discharges. No obligation is imposed by the regulation to monitor for pollutants which are not expected to be present. Of course, permits for discharges of toxic pollutants are likely to require some testing for toxic pollutants during the life of the permit to determine whether significant amounts of toxics are being discharged. See § 122.62(1)(i)(4), which allows permit writers to require monitoring for pollutants not limited in the permit.

Second, the final regulations (§ 122.62(e)) require that permits contain limits to control all toxic pollutants which are used or manufactured by applicants or which are reported at high levels. These limits will include limits on specific toxic pollutants unless the permit writer determines that the discharge of the toxics will be adequately controlled by limits on other pollutants. Limits on individual toxics will require compliance monitoring for the toxics, which could be expensive in some instances. However, this follows inevitably from the statutory requirements that permits assure installation of BAT-level treatment to control discharges of toxic pollutants. § 122.62(e) merely provides certain criteria governing which toxic pollutants may be discharged in significant amounts. EPA expects that where toxics testing would be very expensive, the use of indicator limits or indicator monitoring may help alleviate this problem.

2. Biological Monitoring

In the preamble to the proposed regulations, one of the options presented for compliance monitoring and reporting was the use of toxicity tests in addition to chemical analyses. Under this strategy, toxicity tests would supplement chemical analyses so that chemical testing would be required "sparingly" and acute toxicity tests "on a more frequent basis." EPA reasoned that because toxicity tests are generally less expensive than chemical analyses and may lead to the detection of additional sources of toxicity not controlled by the permit, a useful check on wastestream toxicity could be economically provided as part of the compliance monitoring requirements.

Several commenters, however, argued that biological toxicity information is not relevant or necessary when a permit is based solely on chemical limits and when chemical monitoring is required. Several other commenters favored biomonitoring but objected to performing both chemical and biological testing. The Agency agrees that in most

cases where the permit contains only chemical limitations, toxicity tests should not be required for the purpose of compliance monitoring. However, there may be circumstances where considerable doubt exists concerning the adequacy of the chemical limits employed as permit limits to control all sources of toxicity. In these cases, toxicity tests should be required as part of the monitoring plan not to test for compliance, but to trigger investigations of the cause of remaining toxicity. The investigations could lead to the reopening of the permit to control the newly-found problem. Of course, when toxicity limits are specified in the permit, the appropriate toxicity tests are necessary to ensure compliance.

Several commenters suggested that biomonitoring could completely replace chemical analysis and serve as a compliance indicator to trigger more expensive chemical analysis. However, toxicity testing alone is inadequate because many toxic pollutants are not acutely toxic but bioaccumulate or are carcinogenic or mutagenic. It is important to know whether those pollutants are being discharged. These pollutants would often be discharged below the levels of acute toxicity and not be adequately monitored by acute toxicity tests; long-term threats would thus remain undiscovered. Therefore, toxicity tests should not be used exclusively for compliance monitoring in these cases.

EPA intends to continue to rely on chemical testing to insure compliance with permit limits for specific pollutants. However, the Agency believes that biological toxicity testing is useful to help determine whether the toxicity of discharges in compliance with BAT permit limits has been adequately reduced to assure achievement of fishable and swimmable waters as required by Section 101 of CWA. Therefore, EPA will soon enter into a rulemaking proceeding to require toxicity screening tests for certain dischargers after they have installed BAT.

F. Economic and Resource Impacts of Application Reporting Requirements

1. Unit Costs of Sampling and Analysis

The incremental costs (over those associated with existing application requirements) imposed by the new sampling and analysis requirements consist of the following two elements: (1) costs imposed by the new requirement that certain applicants sample and analyze certain waste streams for some or all of the organic toxic pollutants; and (2) costs imposed

by the revision of current reporting requirements for pollutants other than the organic toxics, including additions to and deletions from the current list of pollutants which must be reported and changes in the nature of reporting for certain pollutants retained on the list.

a. *Sampling and analysis of organic toxics.* For the purpose of calculating a probable cost impact, the Agency is assuming that sampling consists of 24-hour composites (a change from the proposed requirement of 72-hour composites). Analysis is assumed to consist of GC/MS quantification. Applicants may use any method of analysis before the publication of final 304(h) test methods, but the Agency expects that GC/MS will be used most often because of the designation of testing requirements by GC/MS fraction.

Cost data to support the proposal were developed from a variety of sources, which yielded figures over a relatively large range. These data were published in the proposal's preamble and comments were received. The Agency verified the data with additional checking, but some uncertainties remain, including the effect of laboratories' increased use of and familiarity with the analytical methods, the impact of the entry of new laboratories into the market, and the level of quality assurance/quality control (QA/QC) which will be required by final regulations under 40 CFR Part 136. The following cost estimates represent conservatively high judgments based upon unit prices as of Fall 1979.

The Agency received comments from a number of sources on the unit cost of sampling and analysis in the preamble to the proposal. These comments ranged from one which indicated that the Agency cost estimate of \$4500 was an overestimate by \$2,000 of the cost of sampling and analysis to one which suggested that the Agency figure was an underestimate of that cost by a factor of two. Several commenters remarked that the Agency estimates for the cost of sampling and for the cost of GC/MS screening were correct; another commenter confirmed the overall Agency cost estimate. The cost of GC/MS quantification was viewed as an underestimate by several commenters because of their expectations about the cost of quality assurance procedures. However, it was unclear from these comments what the commenters assumed about the nature of the QA/QC procedures to be employed.

Among the comments on the unit cost of sampling and analysis, only those concerning the cost of quality assurance procedures specified the manner in which EPA-assumed unit costs were

regarded as underestimates. The Agency recognizes that GC/MS costs vary with the QA/QC procedures used but feels that today's cost estimates reflect a reasonable upper limit on the cost of the QA/QC procedures which will be used in performing GC/MS analysis.

A second group of comments received by the Agency concerned the assumptions about the number of samples which will be taken by permit applicants. One commenter from the coal mining industry argued that the overall cost calculation was an underestimate because some plants in its industry have as many as 10 outfalls. The Agency acknowledges that the total cost for some applicants will be several times the average cost figure, but also emphasizes that the figures are used to calculate the total incremental cost for the average plants. In addition, it is noted that today's regulations provide for testing exemptions for identical outfalls, which should reduce individual impacts in some cases.

Some commenters regarded the one-sample assumption as an underestimate because of the requirement in the proposal that the sample be representative of the operations of the plant for the previous 12 months. In response to these comments, the requirement in today's instructions is that the time for sampling be representative of the applicant's normal operations. This modification means that the instructions no longer potentially require multiple sampling, but only a somewhat careful choice of sampling time.

The application-based limits provision has been replaced by an application-based reporting requirement in § 122.61(a). This change from the proposal strengthens the likelihood that each applicant will need to collect and analyze only one sample. It makes the potential cost of the application-based limit provision a moot issue.

(i) *Sampling Costs.* Sampling costs will vary significantly, depending on the extent to which the applicant has to rely on an independent contractor rather than in-house personnel to perform the sampling. The instructions state that sampling should be supervised by an experienced supervisor. The sampling costs will also depend on the degree to which the costlier, manual (rather than automated) sampling must be used. The analysis below assumes that the sampling will be performed manually, although either sampling method is allowed.

As noted above, this analysis reflects the change from the proposed requirement for a 72-hour sample to a

24-hour sample, resulting in substantial cost reductions.

Using current prices, the approximate sampling cost breakdown in the case of complete reliance upon independent contractors (assuming the use of a 4-person sampling team for a 2-day sampling trip) is as follows:

- Technicians @ \$80/day, ×3 sampling shifts=\$240×2=\$480
- Supervisor @ \$120/day=\$120×2=\$240
- Reports (1 person-day, supervisor)=\$120
- Overhead on contract salaries (150%)=\$1,260
- Equipment set up on site, 2 man-days=\$160
- Disposable equipment, sample container preparation=\$130
- Sample air transport=\$100
- Subtotal, less personnel air fares, local travel and per diem=\$2,490
- Personnel air fare (estimated average)—\$200/ea.—\$800
- Personnel per diem/local travel—\$50/day/person=\$400
- Total=\$3,690

Costs in a number of these categories, such as salaries, overhead rates, and air fare may vary significantly. However, the Agency believes that \$3,690 is a reasonable estimate of the discharger's cost to have an independent 4-person team to undertake a 2-day sampling trip.

The situation described above is the most expensive case. By using an experienced contract supervisor and possibly contract sampling equipment together with in-house technicians, sampling costs may be reduced by approximately \$1850 because overhead, travel, and salary expenses associated with the three contractor technicians are eliminated. This leaves a net sampling cost of approximately \$1825 per 24-hour composite sample collected manually.

If a sampling team can sample at least two outfalls simultaneously, additional savings can be achieved because personnel-related costs need not be duplicated. The cost of a two outfalls sample is \$2,520; \$1260 per outfall. The increase in cost of nearly \$700 is due to additional expenditures for report preparation, overhead, equipment, sample transport, and equipment set-up.

For computing the total incremental cost of complying with the application requirements (section F(3) below), an average sampling cost of \$1,550 per outfall, which is halfway between \$1,260 and \$1,825, will be assumed.

(ii) *Cost of Analysis by GC/MS Quantification.* For the purpose of determining the cost of GC/MS testing, it is assumed that applicants will forward their samples to independent laboratories for analysis. The Agency has received data on GC/MS costs from several sources, including Agency experience with effluent guidelines development, industry, independent

laboratories, and GC/MS equipment manufacturers.

The data from these sources, together with the fact that increased volume and improved technology have been steadily reducing costs, indicate that a reasonable estimate of GC/MS testing costs (with some QA/QC) is \$1,500 to \$2,000. This estimate does not take into account that applicants in more than half of the industries can omit analysis of at least one GC/MS fraction, and is thus an overestimate of the total cost. The potential for savings from this exclusion is up to \$500 per applicant. For purposes of computing the total incremental cost of complying with the application requirements, the Agency is assuming the cost of GC/MS testing is \$2,000. Adding \$2,000 for analysis to the assumed average sampling cost of \$1,550, the average cost of sampling and analyzing the toxic organics is estimated to be \$3,550 per outfall.

b. *Sampling and analysis of pollutants other than the organic toxic pollutants.* The methods for analyzing for most of the pollutants other than the organic toxics (e.g., metals, ammonia, and other inorganic pollutants) are well established. Cost data for these pollutants are therefore more certain than the cost data for organic pollutants.

Section III.D.2.B of this preamble discusses the new requirements and indicates changes from the June 14 proposal. The modifications in the testing requirements from the proposal will result in little or no change in cost from those assumed in the proposal. Little or no change in sampling costs will result from today's requirements. Analytical cost will increase slightly.

The Agency estimates that incremental sampling and analysis costs for pollutants other than the organic toxics will range between \$180 to \$400. For purposes of computing the total incremental economic impacts in section III.F.3 below, an incremental cost of \$300 is assumed.

2. Unit Reporting Costs

The preparation of the information which is required by § 122.53(d) (discussed in section III.D of this preamble) will require stafftime, resulting in costs in addition to the analytical testing costs. These reporting costs include data development; collection and compilation by various levels of the applicant's staff (clerical, administrative and professional); and review by legal advisors, professional supervisors, and managers.

Unit reporting cost are summarized in Table V.

Table V reflects two modifications in the Agency analysis made since the

proposal. One is the elimination of the item requiring attachment of a BMP program. The other modification is the result of a change in reporting requirements for section 311 discharges. In the proposal an applicant had the option of reporting discharges of hazardous substance in order to claim exemption from section 311 requirements. The final Agency regulations (44 FR 50766; August 29, 1979) provide that an applicant need not report hazardous substances discharges as part of its NPDES application to obtain a section 311 exclusion if the discharges have otherwise been made a part of the public record. Therefore, the costs to prepare this information have been omitted from Table V. (For the remaining application requirement on hazardous substances see item V-D of Form 2c.) The net result of these modifications is a significant reduction in unit reporting costs.

The unit reporting costs will vary depending on the nature and extent of the applicant's relevant activities and on the applicability of various reporting requirements to the applicant. The Agency chose in the proposal to calculate total costs by examining the burden for a typical plant in each of four categories: primary major, primary minor, secondary major, secondary minor. Costs are highest for primary majors and lowest for secondary minors.

The chief assumptions underlying the calculations are:

1. Primary industry dischargers will in general expend greater effort to study waste stream variability for toxic pollutants (including an examination of processes and raw materials) than secondary industry dischargers.

2. Major dischargers will generally have more complex operations than minor dischargers. For major dischargers, large numbers of different processes may create complex waste streams which are then discharged through several outfalls. These considerations will require major dischargers to expend significantly more resources than minor dischargers.

The unit reporting cost of the new application form, on which no substantive comments were received, are summarized in Table V.

Table V.—Unit Reporting Costs of New Application Form (Hours/Source)

Type of question	Primary industry discharger		Secondary industry discharger	
	Major	Minor	Major	Minor
General information.....	3	2	3	2
Environmental engineering data.....	22	8	16	6

Table V.—Unit Reporting Costs of New Application Form (Hours/Source)

Management of analytical data.....	34	26	21	6
Graphics.....	4	4	4	4
Potential discharges not covered by analysis.....	26	14	4	2
Total.....	89	54	48	20

To assess the incremental reporting impact of the new form over the old form, the total unit reporting costs of the old form were also assessed. It should be noted that the reporting cost assessments performed for Office of Management and Budget on the original NPDES application form indicated an unusually low unit cost of completing that form. This low original baseline cost is attributable to the fact that a large portion of the NPDES application requirements were fulfilled in many cases by submitting applications completed under the old Refuse Act Permit Program (RAPP) administered by the U.S. Army Corps of Engineers. When the NPDES program came into being, these RAPP applications were often accepted as NPDES applications, so that the reporting costs of the original form were reported as incremental costs. For this reason, the total cost of the old form was recalculated.

These recalculated unit reporting costs are summarized in Table VI.

Table VI.—Unit Reporting Cost of Old Application Form (Hours/Source)

Type of question	Primary industry discharger		Secondary industry discharger	
	Major	Minor	Major	Minor
General Information.....	3	2	3	2
Environmental engineering data.....	44	18	36	18
Management of analytical data.....	17	7	14	4
Graphics.....	4	4	4	4
Potential discharges not covered by analysis.....	0	0	0	0
Total.....	68	31	57	28

The reporting burdens imposed by the new application requirements are comparable to those imposed by the expiring form. A number of unnecessary and burdensome requirements in the expiring application form have been deleted, but these deletions are largely offset by expanded and new requirements.

The hourly reporting costs shown in Tables V and VI were translated into dollars by determining the time spent answering each type of question shown in those tables by three levels of personnel: administrative and clerical (assumed to be \$10/hour); mid-level business and technical (\$25/hour); and professional, legal and managerial (\$50/

hour). (No adjustments for inflation have been made in the compensation levels since the proposal.)

Based on the above, the incremental unit reporting cost of the new form is presented in Table VII.

Table VII.—Incremental Unit Costs of New Application Form

	Primary industry discharger		Secondary industry discharger	
	Major	Minor	Major	Minor
Old Form Cost.....	\$1855	\$765	\$1520	\$665
New Form Cost.....	2715	1565	1790	775
Incremental Cost.....	\$860	\$800	\$270	\$110

Table VII illustrates that while the unit reporting cost of the new form is greater than the cost for the old form, the new form focuses reporting requirements on those industries with the greatest potential for toxic discharges (primary industries). Note, however, that the incremental cost shown above for secondary industry minor dischargers is probably understated since some of these dischargers completed a special "short form" rather than the complete NPDES application form analyzed in Table VI above.

3. Total Incremental Costs of Complying With the Proposed Application Requirements

This section discusses the total additional costs imposed by the application requirements of §§ 122.53(d) and 122.4(d) over those imposed by existing requirements. The Agency has computed the total incremental costs of its new requirements during fiscal years 1981-1985 (the period for which the new application requirements will be effective) by multiplying the unit costs derived above by the number of applicants or activities which are expected to incur those costs during the period FY 1981-FY 1985. The facts, estimates and assumptions used to compute the total incremental costs of the form are summarized in Table VIII.

a. Number of applicants. The number of existing industrial dischargers who will use the new application form during FY 1981-FY 1985 is based upon the Agency's records of dischargers who currently have permits and may be expected to reapply upon permit expiration.

It should be noted that some dischargers will have had their effluents tested by EPA as part of EPA's effluent guidelines development program. In general, those test results may be reported and the applicant need not perform the sampling and analysis. It is estimated that approximately 100

applicants will be able to take advantage of this provision. However, the analysis below assumes that all applicants will do their own testing; thus the estimated total cost is probably an overestimate.

b. Number of outfalls per applicant. The Agency has estimated the average number of outfalls per discharger, based upon information received from EPA's Regional offices and from State offices. Due to information received from the Regional offices since the proposal, the estimated average number of non-process wastewater outfalls per major discharger has been reduced. Major dischargers are now assumed to average one and a half non-process wastewater outfalls each. Minor dischargers are assumed to average one non-process wastewater outfall and one half of a process wastewater outfall each. These are averages used for computation of total impacts; particular plants may differ significantly. For example, as some commenters stated, certain major dischargers have as many as 10 process wastewater outfalls. However, these situations are balanced by those in which dischargers have no process wastewater outfalls.

c. Number of intakes to be tested by applicants. In addition to sampling and analyzing outfalls, some applicants will be testing their intakes to obtain credit for pollutants in their intakes under 40 CFR 122.63(h).

EPA took several factors into account in coming up with its estimate that one-third of all applicants will test one intake point. First, credit is available only under certain circumstances. For example, the intake source must be the same body of surface water (as opposed to a well, piped-in supply or other source) that receives the discharge for which the credit is sought. Also, plants with many outfalls generally have only one source of surface water influent (e.g., a single adjacent stream or lake). Furthermore, the elimination of application-based limits from the regulations will reduce the number of analyses below the number contemplated in the proposal.

Based on the number of dischargers, tested intakes, process wastewater outfalls and nonprocess wastewater outfalls summarized below, Table IX sets forth subtotals and totals of the costs imposed by the regulations during FY 1981-1985.

The total incremental cost of complying with the application requirements over a five year period is approximately \$51 million. More than three-fourths of that cost will be borne by primary industry applicants.

Approximately 45% of this primary industry cost will be incurred between April 1980 and June 1981; more than a third of this cost will be borne between July 1981 and June 1984. Therefore, calculation of a meaningful annualized cost figure presents difficulties. Because the total cost over five years is less than \$100 million (the threshold for a regulatory analysis), the annualized cost clearly would not exceed the threshold no matter how the annualized cost is calculated.

The Agency believes that the aggregate cost figure overestimates the impact of the application requirements for several reasons. Most important, some primary industry applicants whose permits expire prior to December 1, 1980 are not required to submit the new application forms. (See discussion in preamble to the consolidated regulations found elsewhere in today's Federal Register, at 40 CFR 122.53(c).) Approximately one-sixth of the primary industry applicants and probably a similar portion of the secondary industry applicants fall into this category. (However, if issued short-term permits, they will be required to reapply before June 1981, using the new application form.)

Second, the Agency is assuming that each applicant will hire an independent contractor to perform sampling and that each applicant will send its samples to an independent laboratory for analysis. To the extent that applicants can perform the sampling and analysis internally, substantial savings can be achieved.

Third, the Agency's assumptions about the number of pipes per plant and

about the number of intake pipes which will be tested are probably high.

Fourth, the cost figure does not take into account that applicants in more than half of the primary industries will not have to test for certain GC/MS fractions when analyzing their samples. This could result in savings of up to a fourth of the analytical costs in these industries.

Fifth, the aggregate cost figure does not reflect the savings which will result from the general small business exemption and from the small coal mine exemption (discussed in section III.F.6 below). These savings could be substantial for the coal mine exemption because several thousand applicants are involved.

The Agency is assuming that there will be no cost for secondary industry applicants to sample and analyze for organic toxics. However, secondary industry applicants are required to test for those organic toxic pollutants which they know or have reason to believe are present in their discharge. Therefore, some secondary industry applicants will test for some of the organic toxics if they know or have reason to believe that they are discharging those toxics. However, the Agency believes that the above assumption results in only a slight underestimate because these applicants are unlikely to have to test for many organic toxic pollutants because of the nature of their discharges. The Agency believes that any underestimate is compensated for by overestimates elsewhere and has not attempted to quantify the amount of additional testing, because little or no information is available (none was supplied by commenters).

4. Economic Impacts Upon Selected Industries

The Agency conducted an analysis of the economic impact of the revised application reporting requirements upon primary industry dischargers with process wastewater discharges (upon whom the chief burden of the new requirements falls). The analysis focused primarily on those facilities which will be most affected: marginal, small volume facilities in primary industries. The analysis was conducted for five industries—leather tanning, wood preserving, electroplating, foundries, and iron and steel. The first four industries were selected because many of the plants are small and thus more sensitive to newly imposed cost burdens than other industries. The iron and steel industry was selected to examine the analytical costs for a typical plant which contains a large number of process wastewater outfalls, resulting in correspondingly large analytical costs. No industry was discovered which consisted predominantly of small firms with more than one process wastewater outfall.

Costs vary significantly from plant to plant depending on the number of outfalls at a particular plant. The combined analytical and reporting costs for a plant with one process wastewater outfall will be small, on the order of \$5,000, while the cost to a steelmaking facility with 10 process wastewater outfalls may be as high as \$35,000.

The impact on prices, profits, and plant closures should be small for most industries although impacts may be significant in individual cases. Although the Agency has concluded that the application requirements will not force closures, small businesses with highly toxic, variable, or complex discharges may find the requirements burdensome. In an effort to minimize this burden, the Agency is including a small business exemption in the testing requirements (see section III.F.6 below).

The key economic indicators examined to estimate economic impacts are the ratios of testing costs to sales, to profits, and to total pollution control investment. The ratio of testing cost to sales indicates impact on price increases while the ratio of testing cost to profit provides a rough indication of impact on profits and of the possibility of closures. Table X summarizes the results for average small plants in each industry analyzed during the year that the permit application is submitted. These results represent changes from Table X in the proposal due to the decrease in the estimated testing costs.

Table VIII.—Basis for Calculating Incremental Costs
[For fiscal years 1981-85]

	Primary industry discharger		Secondary industry discharger		Total
	Major	Minor	Major	Minor	
Number of dischargers.....	1,500	6,300	700	16,100	24,600
Number of intakes tested.....	500	2,100	230	5,370	8,200
Number of process wastewater outfalls.....	2,250	3,150	1,050	8,050	14,500
Number of non-process wastewater outfalls.....	2,250	6,300	1,050	16,100	25,700

Table IX.—Total Incremental Costs of New Application Form
[Rounded to the nearest thousand]

	Primary industry discharger		Secondary industry discharger		Total
	Major	Minor	Major	Minor	
Cost of Sampling and Analyzing for Organic Toxics.....	\$9,763,000	\$18,638,000	0	0	\$28,401,000
Incremental Cost of Sampling and Analyzing for Pollutants Other Than Organic Toxics.....	1,500,000	3,465,000	\$989,000	\$8,856,000	14,520,000
Incremental Reporting Cost.....	1,290,000	5,040,000	189,000	1,771,000	8,290,000
Total Incremental Cost.....					51,211,000

For a more detailed analysis of the impact of the regulation on each of the five industries, the reader is referred to the preamble of the proposed regulation (44 FR 34393 at 34412-3, June 14, 1979). That discussion should be read with the modifications in Table X below in mind. The Agency received no comments on that portion of the analysis.

Table X.—Economic Impacts of Testing Costs

(Figures in percentages)

Industry	Ratio of testing costs to—		
	Sales	Profits	Pollution Control Cost
Small Tanneries.....	.09	4.6	1.1
Wood Preservers.....	2.4	N/A*	5.5
Electroplaters (1-4 person job shops).....	4.4	55	N/A*
Foundries (10 person shops).....	1.6	31.5	N/A*
Iron and Steel.....	N/A*	N/A*	.75-1.5

*N/A means information is not available.

5. Impact of Reporting Requirements Upon Independent Laboratory Capability

The Agency received several comments on the proposed regulation which suggested that the NPDES analytical requirements would exceed laboratory capacity for GC/MS analysis. One commenter noted that GC/MS instruments are very expensive and that many applicants will not be able to obtain one. The analysis of demand for independent laboratory GC/MS analyses is based on the assumption that all analyses will be done by independent laboratories and not by the applicants themselves. To the extent that industry associations and individual applicants possess laboratory capacity for these analyses, the estimate of demand for independent lab capability below is an overestimate.

The impact of other Agency programs has been included in the discussion below in response to a comment. Although it is expected that regulation of toxic pollutants will result in some increase in monitoring requirements for toxic pollutants (see section III.E.1 of this preamble), the Agency has not included the effect of monitoring on the demand for laboratory capacity, as suggested by one commenter, because it anticipates that any increase in monitoring requirements would occur after the period during which lab demand will be at its peak due to the application requirements. In addition, monitoring may in some cases be conducted for a selected group of pollutants by use of GC rather than GC/MS.

After reevaluation, the Agency has concluded that GC/MS laboratory capacity should be sufficient to meet expected demand, although some delays in obtaining analytical services may occur during the peak period from April 1980 to June 1981.

The Agency evaluated expected demand on GC/MS capacity from the application form testing requirements by assuming that all required analyses will be done using GC/MS and that, on average, one analysis will require two runs through the machine. Since the number of process wastewater outfalls and intakes to be tested for the primary industry applicants is estimated to be 8,000, the number of GC/MS runs should be between 8,000 and 16,000.

Analysis of the permit expiration dates for the primary industry applicants indicates that about 45% of GC/MS tests will be performed between April 1980 and June 1981. The range of demand for GC/MS tests is projected to be between 240 and 480 analyses per month during this peak period. Demand for GC/MS capacity from other programs within EPA during the same period is expected to be 650-850 analyses per month.

Agency information and a recent manufacturers survey of available laboratories identified 66 laboratories with 129 GC/MS systems capable of performing the required analyses. (These figures represent increases from those reported in the proposal.) Current laboratory experience indicates that larger laboratories (with 3 or more GC/MS systems and an independent data system) are capable of analyzing 60-80 samples per month. The smaller laboratories are capable of performing 20-25 analyses per month. Approximately one quarter of laboratories are of the larger type. A conservatively low estimate of current laboratory capacity, with a 25% allowance for machine failure, appears to be 2,000 analyses per month on a single shift basis and 4,000 analyses per month on a double shift basis. This capacity is in addition to the in-house GC/MS capacity which many industries and universities have for research and other purposes. Some growth in capacity can be anticipated; GC/MS capability in service laboratories doubled over the two years prior to Summer 1979. This increase is a reflection of how rapidly additional laboratory capacity becomes available to meet demand.

Thus, sufficient capacity appears to exist, especially if the existing

equipment is used on a double shift basis.

6. Small Business Exemption

a. *General.* EPA is exempting any business with annual sales less than \$100,000 (in second quarter 1980 dollars) from the requirement to test for the organic toxic pollutants. To qualify for the exemption the permit applicant must submit to the permitting authority annual sales figures for the most recent three years. The average of those three years must be less than \$100,000 for the applicant to qualify.

In developing the \$100,000 ceiling for this exemption, the Agency used as a guideline its final report implementing Executive Order 12044 (44 FR 30988, May 29, 1979). This report indicates that an analysis of the potential economic impact should be conducted when the additional costs of a regulation exceed 5% of a product's selling price. In this instance, the Agency is using 5% of annual sales as an indicator that the reporting requirements may have an adverse impact on a firm.

As noted above, the average costs of the application requirements are \$3,550 for sampling and analysis of organic toxic pollutants. The incremental unit reporting costs for primary industry minor dischargers, \$1,250 (see Table VII above), are expected to be more typical of the small business firm than the reporting costs of the primary industry major discharger. The sum of these analytical and reporting costs is approximately \$5,000. This would exceed 5% of annual sales if a firm has annual sales of \$100,000 or less.

Based on data secured by the Agency during the development of effluent guidelines, the Agency estimates that between 2 and 5% of primary industry applicants will be eligible for the exemption from the sampling and analysis requirements for the organic toxic pollutants in process wastewater. The typical savings for the individual applicant are expected to be on the order of \$4,100, which is the sum of the cost of analysis for organic toxics and the reporting costs associated with managing the organic toxics data. The estimated total savings from this exemption are expected to be between \$1 million and \$2 million. These reductions in the total number of applicants performing the sampling and analysis of discharges for the organic toxic pollutants have not been taken into account in the calculation of the total incremental cost of this regulation.

It should be noted that this exemption does not preclude the permitting

authority from exercising any of its options to obtain information on organic toxic pollutants under section 308 of CWA. However, the Agency expects that permitting authorities will need to exercise those options in a small number of cases, because these applicants generally exert a minor environmental impact.

b. *Coal Mines.* EPA has fashioned a separate exemption for small coal mines which is somewhat analogous to the general small business exemption discussed in the preceding section. Coal mines which are likely to produce less than 100,000 tons of coal per year, based on predicted or historical production figures, are not required to test for organic toxic pollutants.

In section 507 of the Surface Mining Control and Reclamation Act of 1977 (SMCRA), Congress established a substantial set of application requirements for coal mines, including in part a description of mining methods; maps of land to be affected; identification of affected watersheds; a determination of probable hydrologic consequences of mining and reclamation operations; results of test borings or case samplings; analyses of chemical properties of the coal; the sulfur content of coal seams; chemical analyses of potentially acid or toxic forming sections of the overburden; and chemical analyses of the stratum immediately underneath the coal to be mined.

Due to the appropriately extensive application requirements of SMCRA, EPA is seeking to minimize its requests for either duplicative or overly burdensome information. This is part of the broad efforts by EPA and the Department of Interior's Office of Surface Mining (OSM), which regulates coal mines under SMCRA (see 30 CFR Chapter VII), to coordinate their permitting and other activities. See, e.g., 44 FR 55322, September 25, 1979 (announcing the availability for public comment of a draft Memorandum of Understanding on permit coordination between EPA and OSM). EPA has therefore decided to require testing for organic toxic pollutants only in the case of large coal mines, whose discharges, if toxic, are likely to have more significant impact on receiving waters than those of small mines. In addition, they should generally be able to afford both to provide the information required under SMCRA and to test for the organic toxic pollutants.

In selecting 100,000 tons annual production as the criterion for distinguishing large coal mines from small ones, EPA was guided by sections 502(c) and 507(c) of SMCRA. Section

507(c) provides that certain hydrological and other information shall, upon written request of the operator of a small coal mine, be developed by a laboratory and paid for by the regulating authority rather than by the coal mine. The cutoff used in that section is 100,000 tons annual production. Section 502(c) uses the same cutoff to provide small coal mines with an extended transition period to comply with the initial regulatory program under SMCRA. EPA feels that the cutoff selected by Congress in sections 502(c) and 507(c) of SMCRA is similarly appropriate here.

EPA expects that the exemption for small coal mines will exempt approximately 80% of all coal mine applicants. Because these small coal mines produce only about 20% of all coal produced in the United States, discharges from larger mines producing 80% of our nation's coal will remain subject to the organic toxic pollutant testing requirements. (Percentages stated in this paragraph are based upon Figures 2 and 3 on pages 6 and 7 of OSM's Final Regulatory Analysis, OSM-RA-1, March 1979.) The estimated total savings from this exemption are expected to be approximately \$8 million, which was not taken into account in Table IX.

IV. PART A OF HAZARDOUS WASTE APPLICATIONS REQUIREMENTS: § 122.24 AND FORM 3

The RCRA permit program differs from the other permit programs covered by these Consolidated Application Forms in providing for an application in two stages. Six months after the promulgation of regulations setting up the RCRA program in its initial form, every facility which is treating, storing, or disposing of hazardous waste must file Part A of the permit application form. These initial regulations are being promulgated today. Part A of the permit application consists of Forms 1 (discussed in Section II of this preamble) and 3 of the Consolidated Permit Application Forms. Form 3 tracks the regulatory requirements of 40 CFR 122.24. Upon filing a Part A permit application in satisfactory form, a hazardous waste management facility (HWM facility) becomes entitled to "interim status," which means that it is not subject to enforcement for operating without a permit.

About a year from now the full RCRA permit program will become effective. Facilities may then be required by the permitting authority to complete their permit applications by submitting Part B of the permit application. Part B will also be submitted by persons wishing to construct and operate new HWM

facilities. The permitting authority will then proceed to process the application and issue a permit. Part B will be submitted as a narrative; EPA is not promulgating a form for it.

Only limited portions of the requirements for Part B of the permit application are being promulgated today. They are set forth at 40 CFR 122.25. The remaining portions will be promulgated with the rest of the initial set of RCRA requirements in the fall of 1980.

Form 3 is required to be used presently by all existing HWM facilities and by new HWM facilities seeking EPA permits. Under RCRA, States may in the future operate the permit program. Although EPA encourages States with approved RCRA permit programs to use the Federal application forms, or forms as similar to those forms as possible, it is not requiring the use of EPA forms. States may use their own forms, subject to EPA approval, provided that those forms incorporate the application requirements of 40 CFR Part 122, Subpart B.

The above is a simple sketch of the basic features of the RCRA permit program. A far more detailed description is contained in 40 CFR Parts 122, 123 and 124, and the preambles to them, published elsewhere in today's Federal Register. The general outlines of the program will not be discussed further here.

Instead, the balance of this preamble discusses the comments received on the Part A application requirements which are specific to RCRA, namely the comments on Form 3 of the Consolidated Application Forms (Part A). Comments on the provisions of 40 CFR 122.24, which discusses Part A, are also discussed. However, comments on Part B application requirements are discussed in Part 122 and not here, both because there is no set "form" for Part B and because the complete requirements have not yet been promulgated.

Probably the single point most emphasized in the comments on Form 3 was that it was too long and cumbersome to fill out. Commenters stressed that EPA would be receiving many thousands of these forms in a very short time, at the same time that other aspects of the RCRA program were starting up. Therefore, commenters felt, EPA would probably not have the time to review extensive forms in detail; thus the information would not serve a significant regulatory purpose and would be in conflict with Congressional intent that interim status be relatively easy to apply for.

EPA agrees with these comments and has accepted many of them. Specifically:

1. EPA has reduced the specificity with which waste must be described. The proposal would have required the DOT shipping name, the EPA-assigned hazardous waste number, and the common name for all wastes. In the final version, EPA will require the EPA number only.

2. The proposal would have required a listing of the exact quantity of each type of waste to be handled at the facility. In response to comments, this has been changed to an estimate of the quantities.

3. The requirements for submitting "all available" drawings and specifications relating to a HWM facility, contained in the proposal, has been greatly cut back. All that will now be required is a scale drawing and photographs of the existing structures. EPA agreed with the commenters that argued that the proposed requirements could have resulted in the submission of vast quantities of paper that would have had little practical regulatory use.

4. The requirement to submit the zoning status of the site set forth in the proposal has been dropped, as some commenters suggested. EPA assumes that as a general rule existing facilities conform to the applicable zoning requirements and that applications for new facilities as a practical matter will only be filed for locations where the local land use laws would permit it. Accordingly, no general regulatory purpose would be served by requiring this information to be listed in all cases. EPA acknowledges that there may be cases where zoning questions may become extremely important to a decision on an individual facility, and where questions of Federal pre-emption may arise. The preamble to the Part 123 regulations discusses some of the points involved. However, those instances should be rare enough to permit the necessary information to be gathered on a case-by-case basis.

5. There will no longer be special requirements for experimental or health care facilities since those special permit categories have been dropped from the final regulations.

However, EPA has not accepted all the suggestions for simplification and in some cases has added items to the form as proposed or has changed items while leaving basic substantive requirements in place.

Specifically, EPA will still require a list of the exact wastes that will be handled in each facility, broken down by EPA code number, and a list of the treatment, storage, and disposal methods that will be used. The latter requirement replaces the one in the proposal for listing a "handling code."

This information is needed to establish how the existing pattern of HWM facilities deals with the national "universe" of hazardous wastes which will have been defined at the same time. That information will tell EPA which facilities are most in need of regulatory attention (for example, because they are dealing with large quantities of wastes, or because the wastes they deal with are particularly hazardous, or because their treatment, storage, or disposal methods from the description given seem open to question).

In addition to the above, several less significant changes have been made in Form 3:

1. A listing of the latitude and longitude of each facility is now required. This will furnish EPA with more precise data on the location of HWM facilities.

2. The proposed form would have required applicants to specify whether the facility was existing, proposed, or under construction. This requirement has been replaced in the final form with a requirement to list whether the facility is new or existing, whether the permit application is new or revised, and whether the facility has a RCRA permit or interim status. These are the permitting categories which the statute and the implementing regulations lay down, and to require the forms to reflect them will make it easier to handle those forms and assign the action required under them to its proper category.

3. Applicants with existing facilities are now required to indicate the date that operation began or the date construction commenced at their facility. This information will help EPA verify that the facility qualifies for interim status. For new facilities, applicants are required to provide the date that operation is expected to begin. This information will assist EPA in setting priorities for processing applications for new facilities.

4. As discussed in the preamble to Part 122, RCRA permits bind both the owner and the operator of HWM facilities where those two persons are different. Accordingly, the form provides for the signature of both these persons.

Impact of Form 3 reporting requirements. It is estimated that approximately 26,400 owners and operators of hazardous waste management facilities will be required to complete and submit Form 3. The estimated workload and economic burden on these applicants is summarized in Table XI.

Number of respondents.....	26,400
Frequency of response.....	once

Work hours to prepare response...15.1 per response
 Cost to prepare response..... \$472 per response

Evaluation Plan.

EPA will review the usefulness and continued need for the consolidated application forms no later than 5 years from their effective date. The review will consider the effectiveness of the consolidated format; the usefulness of the required information in issuing permits and meeting other program needs; the need to change certain requirements to reflect statutory and regulatory changes and changing program priorities; financial and administrative burdens placed upon EPA, State agencies, and the regulated community; and any more effective or less costly alternative, to fulfill the purposes intended by the current application requirements. The review will be conducted, as the present requirements have been developed, through various means calculated to encourage participation by all interested members of the public as well as by permit writers and permittees.

Note.—Executive Order 11821, as amended by Executive Order 11949, and OMB Circular A-197 require the preparation of economic impact statements for major regulations, defined as those with incremental annual impacts exceeding one hundred million dollars. As demonstrated in this preamble, the Environmental Protection Agency has examined costs and economic impacts as part of its decision-making process. It has determined, based on this analysis, that this document does not constitute a major regulation requiring the preparation of a separate economic impact statement. However, it believes that the detailed analysis contained in section III-F of this preamble complies with the spirit and purpose of the executive orders and OMB circular.

Dated: May 2, 1980.
 Douglas M. Costle,
 Administrator.

Instructions for Consolidated Permit Application Forms

The Consolidated Permit Application Forms are:

- Form 1—General Information
- Form 2—Discharges to Surface Water (NPDES Permits)
 - a. Publicly Owned Treatment Works [Reserved]
 - b. Concentrated Animal Feeding; Operations and Aquatic Animal Production Facilities
 - c. Existing Manufacturing, Commercial, Mining, and Silvicultural Operations
 - d. New Manufacturing, Commercial, Mining and Silvicultural Operations [Reserved]
- Form 3—Hazardous Waste Application Form (RCRA Permits)
- Form 4—Underground Injection of Fluids (UIC Permits) [Reserved]

Form 5—Air Emissions in Attainment Areas (PSD permits) [Reserved]

Table of Contents of This Packet

- A. General Instructions
- B. Instructions for Form 1
- C. Activities Which Do Not Require Permits
- D. Glossary
- E. Form 1

Instructions for Consolidated Permit Application Forms

Section A. General Instructions

Who Must Apply?

With the exceptions described in section C of these instructions, Federal laws prohibit you from conducting any of the following activities without a permit.

NPDES (National Pollutant Discharge Elimination System under the Clean Water Act, 33 U.S.C. 1251). Discharge of pollutants into the waters of the United States.

RCRA (Resource Conservation and Recovery Act, 42 U.S.C. 6901). Treatment, storage, or disposal of hazardous wastes.

UIC (Underground Injection Control under the Safe Drinking Water Act, 42 U.S.C. 300f). Injection of fluids underground by gravity flow or pumping.

PSD (Prevention of Significant Deterioration under the Clean Air Act, 72 U.S.C. 7401). Emission of an air pollutant by a new or modified facility in or near an area which has attained the National Ambient Air Quality Standards for that pollutant.

Each of the above permit programs is operated in any particular State by either the United States Environmental Protection Agency (EPA) or by an approved State agency. You must use this application form to apply for a permit for those programs administered by EPA. For those programs administered by approved States, contact the State environmental agency for the proper forms.

If you have any questions about whether you need a permit under any of the above programs, or if you need information as to whether a particular program is administered by EPA or a State agency or if you need to obtain application forms, contact your EPA Regional office (listed in Table 1).

Upon your request, and based upon information supplied by you, EPA will determine whether you are required to obtain a permit for a particular facility. Contact your EPA Regional office (listed in Table 1). Be sure to contact EPA if you have a question, because Federal laws provide that *you may be heavily penalized if you do not apply for a permit when a permit is required.*

Form 1 of the EPA consolidated application forms (attached to these instructions) collects general information applying to all programs. You must fill out Form 1 regardless of which permit you are applying for. In addition, you must fill out one of the supplementary forms (Forms 2-5) for each permit needed under each of the above programs. Item II of Form 1 will guide you to the appropriate supplementary forms.

You should note that there are certain exclusions to the permit requirements listed above. The exclusions are described in detail in section C of these instructions. If your activities are excluded from permit requirements then you do not need to complete and return any forms.

Note: Certain activities not listed above also are subject to EPA-administered environmental permit requirements. These include permits for ocean dumping, dredged or fill material discharging, and certain types of air emissions. Contact your EPA Regional office for further information.

Table 1.—Addresses of EPA Regional Offices and States Within Their Jurisdiction

Region I

Permit Contact, Environmental and Economic Impact Office, U.S. Environmental Protection Agency, John F. Kennedy Building, Boston, Massachusetts 02203, (617) 223-4635, FTS 223-4635. Connecticut, Maine, Massachusetts, New Hampshire, Rhode Island, Vermont.

Region II

Permit Contact, Permits Administration Branch, Room 432, U.S. Environmental Protection Agency, 26 Federal Plaza, New York, New York 10007, (212) 264-9880, FTS 264-9880. New Jersey, New York, Virgin Islands, Puerto Rico.

Region III

Permit Contact (3 EN 23), U.S. Environmental Protection Agency, 6th & Walnut Streets, Philadelphia, Pennsylvania 19106, (215) 597-8816, FTS 597-8816. Delaware, District of Columbia, Maryland, Pennsylvania, Virginia, West Virginia.

Region IV

Permit Contact, Permits Section, U.S. Environmental Protection Agency, 345 Courtland Street, N.E., Atlanta, Georgia 30365, (404) 881-2017, FTS 257-2017. Alabama, Florida, Georgia, Kentucky, Mississippi, North Carolina, South Carolina, Tennessee.

Region V

Permit Contact (5EP), U.S. Environmental Protection Agency, 230 South Dearborn Street, Chicago, Illinois 60604, (312) 353-2105, FTS 353-2105. Illinois, Indiana, Michigan, Minnesota, Ohio, Wisconsin.

Region VI

Permit Contact (6AEP), U.S. Environmental Protection Agency, First International Building, 1201 Elm Street, Dallas, Texas 75270, (214) 767-2765, FTS 729-2765. Arkansas, Louisiana, New Mexico, Oklahoma, Texas.

Region VII

Permit Contact, Permits Branch, U.S. Environmental Protection Agency, 324 East 11th Street, Kansas City, Missouri 64106, (816) 758-5955, FTS 758-5955. Iowa, Kansas, Missouri, Nebraska.

Region VIII

Permit Contact (8E-WE), Suite 103, U.S. Environmental Protection Agency, 1816 Lincoln Street, Denver, Colorado 80203, (303) 837-4901, FTS 837-4901. Colorado, Montana, North Dakota, South Dakota, Utah, Wyoming.

Region IX

Permit Contact Permits Branch (E-4), U.S. Environmental Protection Agency, 215 Freemont Street, San Francisco, California 94105, (415) 558-3450, FTS 558-3450. Arizona, California, Hawaii, Nevada, Guam, American Samoa, Trust Territories.

Region X

Permit Contact, (M/S 521), U.S. Environmental Protection Agency, 1200 6th Avenue, Seattle, Washington 98101, (206) 442-7176, FTS 399-7176. Alaska, Idaho, Oregon, Washington.

Where To File

The application forms should be mailed to the EPA Regional office whose Region includes the State in which the facility is located (see Table 1).

If the State in which the facility is located administers a Federal permit program under which you need a permit, you should contact the appropriate State agency for the correct forms. Your EPA Regional Office (Table 1) can tell you to whom to apply and can provide the appropriate address and phone number.

When To File

Because of statutory requirements, the deadlines for filing applications vary according to the type of facility you operate and the type of permit you need. These deadlines are as follows:¹

Table 2.—Filing Dates for Permits

Form (permit)	When to file
2a (NPDES)	180 days before your present NPDES permit expires
2b (NPDES)	180 days before your present NPDES permit expires ¹ , or 180 days prior to startup if you are a new facility

¹ Please note that some of these forms are not yet available for use and are listed as "Reserved" at the beginning of these instructions. Contact your EPA Regional office for information on current application requirements and forms.

Table 2.—Filing Dates for Permits—Continued

Form (permit)	When to file
2c (NPDES)	180 days before your present NPDES permit expires ²
2d (NPDES)	180 days prior to startup
3 (Hazardous Waste)	Existing facility: 180 days following publication of regulations listing hazardous wastes New facility: 180 days before commencing physical construction
4 (UIC)	A reasonable time prior to construction for new wells; as directed by the Director for existing wells
5 (PSD)	Prior to commencement of construction

² If your present permit expires on or before November 30, 1980, the filing date is the date on which your permit expires. If your permit expires during the period December 1, 1980-May 31, 1981, the filing date is 90 days before your permit expires.

Federal regulations provide that you may not begin to construct a new source in the NPDES program, a new hazardous waste management facility, a new injection well or a facility covered by the PSD program before the issuance of a permit under the applicable program. Please note that if you are required to obtain a permit before beginning construction, as described above, you may need to submit your permit application well in advance of an applicable deadline listed in Table 2.

Fees

The U.S. EPA does not require a fee for applying for any permit under the consolidated permit programs. (However, some States which administer one or more of these programs require fees for the permits which they issue.)

Availability of Information to Public

Information contained in these application forms will, upon request, be made available to the public for inspection and copying. However, you may request confidential treatment for certain information which you submit on certain supplementary forms. The specific instructions for each supplementary form state what information on the form, if any, may be claimed as confidential and what procedures govern the claim. No information on Forms 1 and 2 may be claimed as confidential.

Completion of Forms

Unless otherwise specified in instructions to the forms, each item in each form must be answered. To

indicate that each item has been considered, enter "NA," for not applicable, if a particular item does not fit the circumstances or characteristics of your facility or activity.

If you have previously submitted information to EPA or to an approved State agency which answers a question, you may either repeat the information in the space provided or attach a copy of the previous submission. Some items in the form require narrative explanation. If more space is necessary to answer a question, attach a separate sheet entitled "Additional Information."

Financial Assistance for Pollution Control

There are a number of direct loans, loan guarantees, and grants available to firms and communities for pollution control expenditures. These are provided by the Small Business Administration, the Economic Development Administration, the Farmers Home Administration, and the Department of Housing and Urban Development. Each EPA Regional office (Table 1) has an economic assistance coordinator who can provide you with additional information.

EPA's construction grants program under Title II of the Clean Water Act is an additional source of assistance to publicly owned treatment works. Contact your EPA Regional office for details.

Section B. Instructions for Form 1—General Information

This form must be completed by all applicants.

Completing this form. Please type or print in the unshaded areas only. Some items have small graduation marks in the fill-in spaces. These marks indicate the number of characters that may be entered into our data system. The marks are spaced at 1/8" intervals which accommodate elite type (12 characters per inch). If you use another type you may ignore the marks. If you print, place each character between the marks. Abbreviate if necessary to stay within the number of characters allowed for each item. Use one space for breaks between words, but not for punctuation marks unless they are needed to clarify your response.

Item I. Space is provided at the upper right hand corner of Form 1 for insertion of your EPA Identification Number. If you have an existing facility, enter your Identification Number. If you don't know your EPA Identification Number, please contact your EPA Regional office (table 1), which will provide you with your number. If your facility is new (not yet constructed), leave this item blank.

Item II. Answer each question to determine which supplementary forms you need to fill out. Be sure to check the glossary in section D of these instructions for the legal definitions of the bold faced words. Check section C of these instructions to determine whether your activity is excluded from permit requirements.

If you answer "no" to every question, then you do not need a permit, and you do not need to complete and return any of these forms.

If you answer "yes" to any question, then you must complete and file the supplementary form by the deadline listed in Table 2 along with this form. (The applicable form number follows each question and is enclosed in parentheses.) You need not submit a supplementary form if you already have a permit under the appropriate Federal program, unless your permit is due to expire and you wish to renew your permit.

Questions (I) and (J) of Item II refer to major new or modified sources subject to Prevention of Significant Deterioration (PSD) requirements under the Clean Air Act. For the purpose of the PSD program, major sources are defined as (1) sources listed in Table 3 which have the potential to emit 100 tons or more per year emissions, and (2) all other sources with the potential to emit 250 tons or more per year. See section C of these instructions for discussion of exclusions of certain modified sources.

Table 3.—28 Industrial Categories Listed in Section 169(1) of the Clean Air Act of 1977

- Fossil fuel-fired steam generators of more than 250 million BTU per hour heat input
- Coal cleaning plants (with thermal dryers)
- Kraft pulp mills
- Portland cement plants
- Primary zinc smelters
- Iron and steel mill plants
- Primary aluminum ore reduction plants
- Primary copper smelters.
- Municipal incinerators capable of charging more than 250 tons of refuse per day
- Hydrofluoric acid plants
- Nitric acid plants
- Sulfuric acid plants
- Petroleum refineries
- Lime plants
- Phosphate rock processing plants
- Coke oven batteries
- Sulfur recovery plants
- Carbon black plants (furnace process)
- Primary lead smelters
- Fuel conversion plants
- Sintering plants
- Secondary metal production plants
- Chemical process plants.

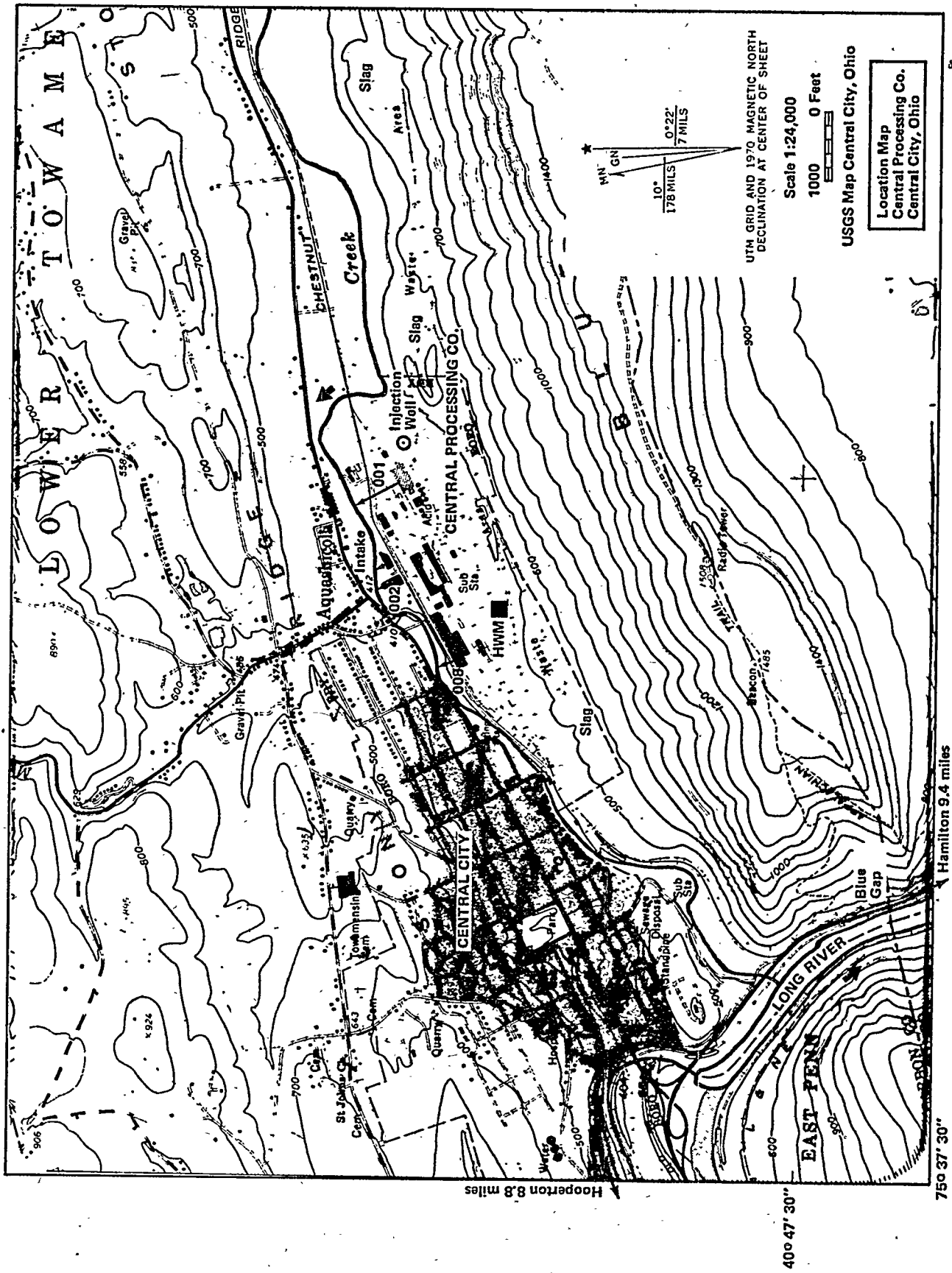

FIGURE A

BILLING CODE 6550-01-C

Item XII. Briefly describe the nature of your business (e.g., products produced or services provided).

Item XIII. Federal statutes provide for severe penalties for submitting false information on this application form.

18 U.S.C. section 1001 provides that "Whoever, in any matter within the jurisdiction of any department or agency of the United States knowingly and willfully falsifies, conceals or covers up by any trick, scheme, or device a material fact, or makes or uses any false writing or document knowing same to contain any false, fictitious or fraudulent statement or entry, shall be fined not more than \$10,000 or imprisoned not more than five years, or both."

Section 309(c)(2) of the Clean Water Act and section 113(c)(2) of the Clean Air Act each provide that "Any person who knowingly makes any false statement, representation, or certification in any application, . . . shall upon conviction, be punished by a fine of no more than \$10,000 or by imprisonment for not more than six months, or both."

In addition, section 3008(d)(3) of the Resource Conservation and Recovery Act provides for a fine up to \$25,000 or imprisonment up to one year for a first conviction for making a false statement in any application under the Act, and for double these penalties upon subsequent convictions.

Federal regulations require this application to be signed as follows:

(1) For a corporation, by a principal executive officer of at least the level of vice president. However, if the only activity in item II which is marked "yes" is Question G, the officer may authorize a person having responsibility for the overall operations of the well or well field to sign the certification. In that case, the authorization must be written and submitted to the permitting authority.

(2) For partnership or sole proprietorship, by a general partner or the proprietor, respectively; or

(3) For a municipality, State, Federal, or other public facility, by either a principal executive officer or ranking elected official.

Section C. Activities Which Do Not Require Permits

I. National Pollutant Discharge Elimination System Permits under the Clean Water Act. You are not required to obtain an NPDES permit if your discharge is in one of the following categories, as provided by the Clean Water Act (CWA) and by the NPDES regulations (40 CFR Parts 122-125). However, under section 510 of CWA a discharge exempted from the federal

NPDES requirements may still be regulated by a State authority; contact your State environmental agency to determine whether you need a State permit.

A. Discharges from Vessels. Discharges of sewage from vessels, effluent from properly functioning marine engines, laundry, shower, and galley sink wastes, and any other discharge incidental to the normal operation of a vessel do not require NPDES permits. However, discharges of rubbish, trash, garbage, or other such materials discharged overboard require permits, and so do other discharges when the vessel is operating in a capacity other than as a means of transportation, such as when the vessel is being used as an energy or mining facility, a storage facility, or a seafood processing facility, or is secured to the bed of the ocean, contiguous zone, or waters of the United States for the purpose of mineral or oil exploration or development.

B. Dredged or Fill Material. Discharges of dredged or fill material into waters of the United States do not need NPDES permits if the dredging or filling is authorized by a permit issued by the U.S. Army Corps of Engineers or an EPA-approved State under section 404 of CWA.

C. Discharges into Publicly Owned Treatment Works (POTW). The introduction of sewage, industrial wastes, or other pollutants into a POTW does not need an NPDES permit. You must comply with all applicable pretreatment standards promulgated under section 307(b) of CWA, which may be included in the permit issued to the POTW. If you have a plan or an agreement to switch to a POTW in the future, this does not relieve you of the obligation to apply for and receive an NPDES permit until you have stopped discharging pollutants into waters of the United States.

[Note: Dischargers into privately owned treatment works do not have to apply for or obtain NPDES permits except as otherwise required by the EPA Regional Administrator. The owner or operator of the treatment works itself, however, must apply for a permit and identify all users in its application. Users so identified will receive public notice of actions taken on the permit for the treatment works.]

D. Discharges from Agricultural and Silvicultural Activities. Most discharges from agricultural and silvicultural activities to waters of the United States do not require NPDES permits. These include runoff from orchards, cultivated crops, pastures, range lands, and forest lands. However, the discharges listed

below do require NPDES permits. Definitions of the terms listed below are contained in the Glossary section of these instructions.

(1) Discharges from Concentrated Animal Feeding Operations. (See Glossary for definitions of "animal feeding operations" and "concentrated animal feeding operations." Only the latter require permits.)

(2) Discharges from Concentrated Aquatic Animal Production Facilities. (See Glossary for size cutoffs.)

(3) Discharges associated with approved Aquaculture Projects.

(4) Discharges from Silvicultural Point Sources. (See Glossary for the definition of "silvicultural point source.") Non-point source silvicultural activities are excluded from NPDES permit requirements. However, some of these activities, such as stream crossings for roads, may involve point source discharges of dredged or fill material which may require a section 404 permit. See 33 CFR 209.120.

E. Discharges in Compliance with an On-Scene Coordinator's Instructions.

II. Hazardous Waste Permits under the Resource Conservation and Recovery Act. You may be excluded from the requirement to obtain a permit under this program if you fall into one of the following categories.

Generators who accumulate their own hazardous waste on-site for less than 90 days;

- Certain small generators;
- Owners or operators of totally enclosed treatment facilities; or
- Farmers who dispose of waste pesticide from their own use.

Check with your Regional office for details. Please note that even if you are excluded from permit requirements, you may be required by Federal regulations to handle your waste in a particular manner.

III. Underground Injection Control Permits under the Safe Drinking Water Act. You are not required to obtain a permit under this program if you:

- Inject into existing wells used to enhance recovery of oil and gas or to store hydrocarbons (note, however, that these underground injections are regulated by Federal rules); or
- Inject into or above a stratum which contains, within ¼ mile of the well bore, an underground source of drinking water (unless your injection is the type identified in item II-H, for which you do need a permit). However, you must notify EPA of your injection and submit certain required information on forms supplied by the Agency, and your operation may be phased out if you are a generator of hazardous wastes or a hazardous waste management facility

which uses wells or septic tanks to dispose of hazardous waste.

IV. Prevention of Significant Deterioration Permits under the Clean Air Act. The PSD program applies to newly constructed or modified facilities (both of which are referred to as "new sources") which increase air emissions. The Clean Air Act Amendments of 1977 exclude small new sources of air emissions from the PSD review program. Any new source in an industrial category listed in Table 3 of these instructions whose potential to emit is less than 100 tons per year is not required to get a PSD permit. In addition, any new source in an industrial category not listed in Table 3 whose potential to emit is less than 250 tons per year is exempted from the PSD requirements.

Modified sources which increase their net emissions (the difference between the total emission increases and total emission decreases at the source) less than the significant amount set forth in EPA regulations are also exempt from PSD requirements. Contact your EPA Regional office (Table 1) for further information.

Section D. Glossary

Note: This Glossary includes terms used in the instructions and in Forms 1, 2b, 2c, and 3. Additional terms will be included in the future when other forms are developed to reflect the requirements of other parts of the consolidated permit program. If you have any questions concerning the meaning of any of these terms, please contact your EPA Regional office (Table 1).

"Aliquot" means a sample of specified volume used to make up a total composite sample.

"Animal feeding operation" means a lot or facility (other than an aquatic animal production facility) where the following conditions are met:

1. Animals (other than aquatic animals) have been, are, or will be stabled or confined and fed or maintained for a total of 45 days or more in any 12-month period, and

2. Crops, vegetation, forage growth, or post-harvest residues are not sustained in the normal growing season over any portion of the lot or facility.

Two or more animal feeding operations under common ownership are a single animal feeding operation if they adjoin each other or if they use a common area or system for the disposal of wastes.

"Animal unit" means a unit of measurement for any animal feeding operation calculated by adding the following numbers: the number of

slaughter and feeder cattle multiplied by 1.0, plus the number of mature dairy cattle multiplied by 1.4, plus the number of swine weighing over 25 kilograms (approximately 55 pounds) multiplied by 0.4, plus the number of sheep multiplied by 0.1, plus the number of horses multiplied by 2.0.

"Application" means the EPA standard national forms for applying for a permit, including any additions, revisions, or modifications to the forms; or forms approved by EPA for use in approved States, including any approved modifications or revisions. For RCRA, "application" also means "Application, Part B."

"Application, Part A" means that part of the consolidated permit application forms which a RCRA permit applicant must complete to qualify for interim status under section 3005(e) of RCRA and for consideration for a permit. Part A consists of Form 1 (General Information) and Form 3 (Hazardous Waste Application Form).

"Application, Part B" means that part of the application which a RCRA permit applicant must complete to be issued a permit. (*Note:* EPA is not developing a specific form for Part B of the permit application, but an instruction booklet explaining what information must be supplied is available from the EPA Regional office.)

"Approved program" or "approved State" means a State program which has been approved or authorized by EPA under 40 CFR Part 123.

"Aquaculture project" means a defined managed water area which uses discharges of pollutants into that designated area for the maintenance or production of harvestable freshwater, estuarine, or marine plants or animals.

"Designated area" means the portions of the waters of the United States within which the applicant plans to confine the cultivated species, using a method of plan or operation (including, but not limited to, physical confinement) which, on the basis of reliable scientific evidence, is expected to ensure the specific individual organisms comprising an aquaculture crop will enjoy increased growth attributable to the discharge of pollutants and be harvested within a defined geographic area.

"Aquifer" means a geological formation, group of formations, or part of a formation that is capable of yielding a significant amount of water to a well or spring.

"Area of review" means the area surrounding an injection well which is described according to the criteria set forth in 40 CFR § 146.06.

"Area permit" means a UIC permit applicable to all or certain wells within

a geographic area, rather than to a specified well, under 40 CFR § 122.37.

"Attainment area" means, for any air pollutant, an area which has been designated under section 107 of the Clean Air Act as having ambient air quality levels better than any national primary or secondary ambient air quality standard for that pollutant. Standards have been set for sulfur oxides, particulate matter, nitrogen dioxide, carbon monoxide, ozone, lead and hydrocarbons. For purposes of the Glossary, "attainment area" also refers to "unclassifiable area," which means, for any pollutants, an area designated under section 107 as unclassifiable with respect to that pollutant due to insufficient information.

"Best Management Practices" ("BMP") means schedules of activities, prohibitions of practices, maintenance procedures, and other management practices to prevent or reduce the pollution of waters of the United States. BMPs include treatment requirements, operating procedures, and practices to control plant site runoff, spillage or leaks, sludge or waste disposal, or drainage from raw material storage.

"Biological monitoring test" means any test which includes the use of aquatic algal, invertebrate, or vertebrate species to measure acute or chronic toxicity, and any biological or chemical measure of bioaccumulation.

"Bypass" means the intentional diversion of wastes from any portion of a treatment facility.

"Concentrated animal feeding operation" means an animal feeding operation which meets the criteria set forth in either (1) or (2) or which the Director designates as such on a case-by-case basis:

1. More than the numbers of animals specified in any of the following categories are confined:

- (A) 1,000 slaughter or feeder cattle,
- (B) 700 mature dairy cattle (whether milked or dry cows),
- (C) 2,500 swine each weighing over 25 kilograms (approximately 55 pounds),
- (D) 500 horses,
- (E) 10,000 sheep or lambs,
- (F) 55,000 turkeys,
- (G) 100,000 laying hens or broilers (if the facility has a continuous overflow watering)

(H) 30,000 laying hens or broilers (if the facility has a liquid manure handling system),

- (I) 5,000 ducks, or
- (J) 1,000 animal units; or

2. More than the following numbers and types of animals are confined:

- (A) 300 slaughter or feeder cattle,
- (B) 200 mature dairy cattle (whether milked or dry cows),

(C) 750 swine each weighing over 25 kilograms (approximately 55 pounds),

(D) 150 horses,

(E) 3,000 sheep or lambs,

(F) 16,500 turkeys,

(G) 30,000 laying hens or broilers (if the facility has continuous overflow watering),

(H) 9,000 laying hens or broilers (if the facility has a liquid manure handling system),

(I) 1,500 ducks, or

(J) 300 animal units;

and either one of the following conditions are met: pollutants are discharged into waters of the United States through a manmade ditch, flushing system or other similar manmade device ("manmade" means constructed by man and used for the purpose of transporting wastes); or pollutants are discharged directly into waters of the United States which originate outside of and pass over, across, or through the facility or otherwise come into direct contact with the animals confined in the operation.

Provided, however, that no animal feeding operation is a concentrated animal feeding operation as defined above if such animal feeding operation discharges only in the event of a 25 year, 24 hour storm event.

"Concentrated aquatic animal production facility" means a hatchery, fish farm, or other facility which contains, grows or holds aquatic animals in either of the following categories, or which the Director designates as such on a case-by-case basis:

1. Cold water fish species or other cold water aquatic animals including, but not limited to, the *Salmonidae* family of fish (e.g., trout and salmon) in ponds, raceways or other similar structures which discharge at least 30 days per year but does not include:

(a) Facilities which produce less than 9,090 harvest weight kilograms (approximately 20,000 pounds) of aquatic animals per year; and

(b) Facilities which feed less than 2,272 kilograms (approximately 5,000 pounds) of food during the calendar month of maximum feeding.

2. Warm water fish species or other warm water aquatic animals including, but not limited to, the *Ameiuridae*, *Cetrarichidae*, and *Cyprinidae* families of fish (e.g., respectively, catfish, sunfish and minnows) in ponds, raceways, or other similar structures which discharge at least 30 days per year, but does not include:

(a) Closed ponds which discharge only during periods of excess runoff; or

(b) Facilities which produce less than 45,454 harvest weight kilograms

(approximately 100,000 pounds) of aquatic animals per year.

"Contact cooling water" means water used to reduce temperature which comes into contact with a raw material, intermediate product, waste product other than heat, or finished product.

"Contiguous zone" means the entire zone established by the United States under article 24 of the convention of the Territorial Sea and the Contiguous Zone.

"CWA" means the Clean Water Act (formerly referred to the Federal Water Pollution Control Act) Pub. L. 92-500, as amended by Pub. L. 95-217 and Pub. L. 95-576, 33 U.S.C. 1251 *et seq.*

"Direct discharge" means the discharge of a pollutant as defined below.

"Director" means the EPA Regional Administrator or the State Director as the context requires.

"Discharge (of a pollutant)" means:

(1) Any addition of any pollutant or combination of pollutants to waters of the United States from any point source, or

(2) Any addition of any pollutant or combination of pollutants to the waters of the contiguous zone or the ocean from any point source other than a vessel or other floating craft which is being used as a means of transportation.

This definition includes discharges into waters of the United States from: surface runoff which is collected or channelled by man; discharges through pipes, sewers, or other conveyances owned by a State, municipality, or other person which do not lead to POTW's; and discharges through pipes, sewers, or other conveyances, leading into privately owned treatment works. This term does not include an addition of pollutants by any indirect discharger.

"Disposal" (in the RCRA program) means the discharge, deposit, injection, dumping, spilling, leaking, or placing of any hazardous waste into or on any land or water so that the hazardous waste or any constituent of it may enter the environment or be emitted into the air or discharged into any waters, including ground water.

"Disposal facility" means a facility or part of a facility at which hazardous waste is intentionally placed into or on land or water, and at which hazardous waste will remain after closure.

"Effluent limitation" means any restriction imposed by the Director on quantities, discharge rates, and concentrations of pollutants which are discharged from point sources into waters of the United States, the waters of the contiguous zone, or the ocean.

"Effluent limitation guideline" means a regulation published by the Administrator under section 304(b) of

the Clean Water Act to adopt or revise effluent limitations.

"Environmental Protection Agency" ("EPA") means the United States Environmental Protection Agency.

"Exempted aquifer" means an aquifer or its portion that meets the criteria in the definition of USDW, but which has been exempted according to the procedures in 40 CFR § 122.35(b).

"Existing HWM facility" means a Hazardous Waste Management facility which was in operation, or for which construction had commenced, on or before October 21, 1976. Construction had commenced if (1) the owner or operator had obtained all necessary Federal, State and local preconstruction approvals or permits, and either (2a) a continuous on-site, physical construction program had begun, or (2b) the owner or operator had entered into contractual obligations, which could not be cancelled or modified without substantial loss, for construction of the facility to be completed within a reasonable time.

[Note: This definition reflects the literal language of the statute. However, EPA believes that amendments to RCRA now in conference will shortly be enacted and will change the date for determining when a facility is an "existing facility" to one no earlier than May of 1980; indications are the conferees are considering October 30, 1980.

Accordingly, EPA encourages every owner or operator of a facility which was built or under construction as of the promulgation date of the RCRA program regulations to file Part A of its permit application so that it can be quickly processed for interim status when the change in the law takes effect. When those amendments are enacted, EPA will amend this definition.]

"Existing source" or "existing discharger" (in the NPDES program) means any source which is not a new source or a new discharger.

"Existing injection well" means an injection well other than a new injection well.

"Facility" means any HWM facility, UIC underground injection well, NPDES point source, PSD stationary source, or any other facility or activity (including land or appurtenances thereto) that is subject to regulation under the RCRA, UIC, NPDES or PSD programs.

"Fluid" means material or substance which flows or moves whether in a semisolid, liquid, sludge, gas, or any other form or state.

"Generator" means any person by site location, whose act or process produces hazardous waste identified or listed in 40 CFR Part 261.

"Groundwater" means water below the land surface in a zone of saturation.

"Hazardous substance" means any of the substances designated under 40 CFR Part 116 pursuant to section 311 of CWA. [Note: These substances are listed in Table 2c-4 of the instructions to Form 2c.]

"Hazardous waste" means a hazardous waste as defined in 40 CFR § 261.3.

"Hazardous waste management facility" ("HWM facility") means all contiguous land, structures, appurtenances, and improvements on the land, used for treating, storing, or disposing of hazardous wastes. A facility may consist of several treatment, storage or disposal operational units (for example, one or more landfills, surface impoundments, or combinations of them).

"In operation" means a facility which is treating, storing, or disposing of hazardous waste.

"Indirect discharger" means a non-domestic discharger introducing pollutants to a publicly owned treatment works.

"Injection well" means a well into which fluids are being injected.

"Interim authorization" means approval by EPA of a State hazardous waste program which has met the requirements of section 3006(c) of RCRA and applicable requirements of 40 CFR Part 123, Subparts A, B, and F.

"Listed State" means a State listed by the Administrator under section 1422 of SDWA as needing a State UIC program.

"MGD" means millions of gallons per day.

"Municipality" means a city, village, town, borough, county, parish, district, association, or other public body created by or under State law and having jurisdiction over disposal of sewage, industrial wastes, or other wastes, or an Indian tribe or an authorized Indian tribal organization, or a designated and approved management agency under section 208 of CWA.

"National Pollutant Discharge Elimination System" ("NPDES") means the national program for issuing, modifying, revoking and reissuing, terminating, monitoring, and enforcing permits and imposing and enforcing pretreatment requirements, under sections 307, 318, 402 and 405 of CWA. The term includes an approved program.

"New discharger" means any building, structure, facility, or installation: (1) from which there is or may be a new or additional discharge of pollutants at a site at which on October 18, 1972, it had never discharged pollutants; (2) which has never received a finally effective NPDES permit for discharges at that site;

and (3) which is not "new source." This definition includes an indirect discharger which commences discharging into waters of the United States. It also includes any existing mobile point source, such as an offshore oil drilling rig, seafood processing vessel; or aggregate plant that begins discharging at a location for which it does not have an existing permit.

"New HWM facility" means a Hazardous Waste Management facility which began operation or for which construction commenced after October 21, 1976.

"New injection well" means a well which begins injection after a UIC program for the State in which the well is located is approved.

"New source" (in the NPDES program) means any building, structure, facility, or installation from which there is or may be a discharge of pollutants, the construction of which commenced:

(i) After promulgation of standards of performance under section 306 of CWA which are applicable to such source, or

(ii) After proposal of standards of performance in accordance with section 306 of CWA which are applicable to such source, but only if the standards are promulgated in accordance with section 306 within 120 days of their proposal.

"Non-contact cooling water" means water used to reduce temperature which does not come into direct contact with any raw material, intermediate product, waste product (other than heat), or finished product.

"Off-site" means any site which is not "on-site."

"On-site" means on the same or geographically contiguous property which may be divided by public or private right(s)-of-way, provided the entrance and exit between the properties is at a cross-roads intersection, and access is by crossing as opposed to going along, the right(s)-of-way. Non-Contiguous properties owned by the same person, but connected by a right-of-way which the person controls and to which the public does not have access, is also considered on-site property.

"Outfall" means a point source.

"Permit" means an authorization, license, or equivalent control document issued by EPA or an approved State to implement the requirements of 40 CFR Parts 122, 123, and 124.

"Physical construction" (in the RCRA program) means excavation, movement of earth, erection of forms or structures, or similar activity to prepare a HWM facility to accept hazardous waste.

"Point source" means any discernible, confined, and discrete conveyance,

including but not limited to any pipe, ditch, channel, tunnel, conduit, well, discrete fissure, container, rolling stock, concentrated animal feeding operation, vessel or other floating craft from which pollutants are or may be discharged. This term does not include return flows from irrigated agriculture.

"Pollutant" means dredged spoil, solid waste, incinerator residue, filter backwash, sewage, garbage, sewage sludge, munitions, chemical waste, biological materials, radioactive materials (except those regulated under the Atomic Energy Act of 1954, as amended (42 U.S.C. § 2011 et seq.)), heat, wrecked or discarded equipment, rocks, sand, cellar dirt and industrial, municipal, and agriculture waste discharged into water. It does not mean:

(1) Sewage from vessels; or

(2) Water, gas, or other material which is injected into a well to facilitate production of oil or gas, or water derived in association with oil and gas production and disposed of in a well, if the well used either to facilitate production or for disposal purposes is approved by authority of the State in which the well is located, and if the State determines that the injection or disposal will not result in the degradation of ground or surface water resources.

[Note: Radioactive materials covered by the Atomic Energy Act are those encompassed in its definition of source, byproduct, or special nuclear materials. Examples of materials not covered include radium and accelerator produced isotopes. See *Train v. Colorado Public Interest Research Group, Inc.*, 426 U.S. 1 (1976).]

"Prevention of significant deterioration" (PSD) means the national permitting program under 40 CFR 52.21 to prevent emissions of certain pollutants regulated under the Clean Air Act from significantly deteriorating air quality in attainment areas.

"Primary industry category" means any industry category listed in the NRDC Settlement Agreement (*Natural Resources Defense Council v. Train*, 8 ERC 2120 (D.D.C. 1976), modified 12 ERC 1833 (D.D.C. 1979)).

"Privately owned treatment works" means any device or system which is (1) used to treat wastes from any facility whose operator is not the operator of the treatment works and (2) not a POTW.

"Process wastewater" means any water which, during manufacturing or processing, comes into direct contact with or results from the production or use of any raw material, intermediate product, finished product, by-product, or waste product.

"Publicly owned treatment works" or "POTW" means any device or system used in the storage, treatment, recycling, and reclamation of municipal sewage or industrial waste of a liquid nature which is owned by a State or municipality. This definition includes any sewers that convey wastewater to a POTW, but does not include pipes, sewers, or other conveyances not connected to a POTW.

"Rent" means use of another's property in return for regular payment.

"RCRA" means the Solid Waste Disposal Act as amended by the Resource Conservation and Recovery Act of 1976 (Pub. L. 94-580, as amended by Pub. L. 95-609, 42 U.S.C. § 6901 *et seq.*).

"Rock crushing and gravel washing facilities" are facilities which process crushed and broken stone, gravel, and riprap (see 40 CFR Part 436, Subpart B, and the effluent limitations guidelines for these facilities).

"SDWA" means the Safe Drinking Water Act (Pub. L. 95-523, as amended by Pub. L. 95-1900, 42 U.S.C. § 300(f) *et seq.*).

"Secondary industry category" means any industry category which is not a primary industry category.

"Sewage from vessels" means human body wastes and the wastes from toilets and other receptacles intended to receive or retain body wastes that are discharged from vessels and regulated under section 312 of CWA, except that with respect to commercial vessels on the Great Lakes this term includes graywater. For the purposes of this definition, "graywater" means galley, bath, and shower water.

"Sewage sludge" means the solids, residues, and precipitate separated from or created in sewage by the unit processes of a POTW. "Sewage" as used in this definition means any wastes, including wastes from humans, households, commercial establishments, industries, and storm water runoff, that are discharged to or otherwise enter a publicly owned treatment works.

"Silvicultural point source" means any discernable, confined, and discrete conveyance related to rock crushing, gravel washing, log sorting, or log storage facilities which are operated in connection with silvicultural activities and from which pollutants are discharged into waters of the United States. This term does not include non-point source silvicultural activities such as nursery operations, site preparation, reforestation and subsequent cultural treatment, thinning, prescribed burning, pest and fire control, harvesting operations, surface drainage, or road construction and maintenance from which there is natural runoff. However,

some of these activities (such as stream crossing for roads) may involve point source discharges of dredged or fill material which may require a CWA section 404 permit. "Log sorting and log storage facilities" are facilities whose discharges result from the holding of unprocessed wood, e.g., logs or roundwood with bark or after removal of bark in self-contained bodies of water (mill ponds or log ponds) or stored on land where water is applied intentionally on the logs (wet decking). (See 40 CFR Part 429, Subpart J, and the effluent limitations guidelines for these facilities.)

"State" means any of the 50 States, the District of Columbia, Guam, the Commonwealth of Puerto Rico, the Virgin Islands, American Samoa, the Trust Territory of the Pacific Islands (except in the case of RCRA), and the Commonwealth of the Northern Mariana Islands (except in the case of CWA).

"Stationary source" (in the PSD program) means any building, structure, facility, or installation which emits or may emit any air pollutant regulated under the Clean Air Act. "Building, structure, facility, or installation" means any grouping of pollutant-emitting activities which are located on one or more contiguous or adjacent properties and which are owned or operated by the same person (or by persons under common control).

"Storage" (in the RCRA program) means the holding of hazardous waste for a temporary period at the end of which the hazardous waste is treated, disposed, or stored elsewhere.

"Storm water runoff" means water discharged as a result of rain, snow, or other precipitation.

"Toxic pollutant" means any pollutant listed as toxic under section 307(a)(1) of CWA.

"Transporter" (in the RCRA program) means a person engaged in the off-site transportation of hazardous waste by air, rail, highway, or water.

"Treatment" (in the RCRA program) means any method, technique, or process, including neutralization, designed to change the physical, chemical, or biological character or composition of any hazardous waste so as to neutralize such waste, or so as to recover energy or material resources from the waste, or so as to render such waste non-hazardous, or less hazardous; safer to transport, store, or dispose of; or amenable for recovery, amenable for storage, or reduced in volume.

"Underground injection" means well injection.

"Underground source of drinking water" or "USDW" means an aquifer or

its portion which is not an exempted aquifer and:

(1) Which supplies drinking water for human consumption, or

(2) In which the ground water contains fewer than 10,000 mg/l total dissolved solids.

"Upset" means an exceptional incident in which there is unintentional and temporary noncompliance with technology-based permit effluent limitations because of factors beyond the reasonable control of the permittee. An upset does not include noncompliance to the extent caused by operational error, improperly designed treatment facilities, inadequate maintenance, lack of preventive operation, or careless or improper operation.

"Waters of the United States" means:

1. All waters which are currently used, were used in the past, or may be susceptible to use in interstate or foreign commerce, including all waters which are subject to the ebb and flow of the tide;

2. All interstate waters, including interstate wetlands;

3. All other waters such as intrastate lakes, rivers, streams (including intermittent streams), mudflats, sandflats, wetlands, sloughs, prairie potholes, wet meadows, playa lakes, and natural ponds, the use, degradation, or destruction of which would or could affect interstate or foreign commerce including any such waters:

(a) Which are or could be used by interstate or foreign travelers for recreational or other purposes;

(b) From which fish or shellfish are or could be taken and sold in interstate or foreign commerce;

(c) Which are used or could be used for industrial purposes by industries in interstate commerce;

4. All impoundments of waters otherwise defined as waters of the United States under this definition;

5. Tributaries of waters identified in paragraphs (1)-(4) above;

6. The territorial sea; and

7. Wetlands adjacent to waters (other than waters that are themselves wetlands) identified in paragraphs (1)-(6) of this definition.

Waste treatment systems, including treatment ponds or lagoons designed to meet requirement of CWA (other than cooling ponds as defined in 40 CFR § 423.11(m) which also meet the criteria of this definition) are not waters of the United States. This exclusion applies only to manmade bodies of water which neither were originally created in waters of the United States (such as a disposal area in wetlands) nor resulted from the

impoundments of waters of the United States.

"Well injection" or "underground injection" means the subsurface emplacement of fluids through a bored, drilled, or driven well; or through a dug well, where the depth of the dug well is greater than the largest surface dimension.

"Wetlands" means those areas that are inundated or saturated by surface or ground water at a frequency and duration sufficient to support, and that under normal circumstances do support, a prevalence of vegetation typically adapted for life in saturated soil conditions. Wetlands generally include swamps, marshes, bogs, and similar areas.

BILLING CODE 6560-01-M

Please print or type in the unshaded areas only
 (fill-in areas are spaced for elite type, i.e., 12 characters/inch).

Form Approved OMB No. 158-R0175

FORM 1		U.S. ENVIRONMENTAL PROTECTION AGENCY GENERAL INFORMATION Consolidated Permits Program (Read the "General Instructions" before starting.)	I. EPA I.D. NUMBER <table border="1" style="width:100%; border-collapse: collapse;"> <tr> <td style="width:10%; text-align: center;">F</td> <td style="width:10%; text-align: center;">G</td> <td style="width:10%; text-align: center;">H</td> <td style="width:10%; text-align: center;">I</td> <td style="width:10%; text-align: center;">J</td> <td style="width:10%; text-align: center;">K</td> <td style="width:10%; text-align: center;">L</td> <td style="width:10%; text-align: center;">M</td> <td style="width:10%; text-align: center;">N</td> <td style="width:10%; text-align: center;">O</td> <td style="width:10%; text-align: center;">P</td> <td style="width:10%; text-align: center;">Q</td> <td style="width:10%; text-align: center;">R</td> <td style="width:10%; text-align: center;">S</td> <td style="width:10%; text-align: center;">T</td> <td style="width:10%; text-align: center;">U</td> <td style="width:10%; text-align: center;">V</td> <td style="width:10%; text-align: center;">W</td> <td style="width:10%; text-align: center;">X</td> <td style="width:10%; text-align: center;">Y</td> <td style="width:10%; text-align: center;">Z</td> </tr> </table>	F	G	H	I	J	K	L	M	N	O	P	Q	R	S	T	U	V	W	X	Y	Z
F	G	H	I	J	K	L	M	N	O	P	Q	R	S	T	U	V	W	X	Y	Z				
LABEL ITEMS I. EPA I.D. NUMBER III. FACILITY NAME V. FACILITY MAILING ADDRESS VI. FACILITY LOCATION		PLEASE PLACE LABEL IN THIS SPACE	GENERAL INSTRUCTIONS If a preprinted label has been provided, affix it in the designated space. Review the information carefully; if any of it is incorrect, cross through it and enter the correct data in the appropriate fill-in area below. Also, if any of the preprinted data is absent (the area to the left of the label space lists the information that should appear), please provide it in the proper fill-in area(s) below. If the label is complete and correct, you need not complete Items I, III, V, and VI except VI-E which must be completed regardless. Complete all items if no label has been provided. Refer to the instructions for detailed item descriptions and for the legal authorizations under which this data is collected.																					

II. POLLUTANT CHARACTERISTICS

INSTRUCTIONS: Complete A through J to determine whether you need to submit any permit application forms to the EPA. If you answer "yes" to any questions, you must submit this form and the supplemental form listed in the parenthesis following the question. Mark "X" in the box in the third column if the supplemental form is attached. If you answer "no" to each question, you need not submit any of these forms. You may answer "no" if your activity is excluded from permit requirements; see Section C of the instructions. See also, Section D of the instructions for definitions of bold-faced terms.

SPECIFIC QUESTIONS	MARK "X" FORM ATTACHED			SPECIFIC QUESTIONS	MARK "X" FORM ATTACHED		
	YES	NO	FORM ATTACHED		YES	NO	FORM ATTACHED
A. Is this facility a publicly owned treatment works which results in a discharge to waters of the U.S. (FORM 2A)				B. Does or will this facility (either existing or proposed) include a concentrated animal feeding operation or aquatic animal production facility which results in a discharge to waters of the U.S.? (FORM 2B)			
C. Is this a facility which currently results in discharges to waters of the U.S. other than those described in A or B above? (FORM 2C)				D. Is this a proposed facility (other than those described in A or B above) which will result in a discharge to waters of the U.S.? (FORM 2D)			
E. Does or will this facility treat, store, or dispose of hazardous wastes? (FORM 3)				F. Do you or will you inject at this facility industrial or municipal effluent below the lowermost stratum containing water in one quarter mile of the well bore, casing, or annulus of drinking water? (FORM 4)			
G. Do you or will you inject at this facility any produced water or other fluids which are brought to the surface in connection with conventional oil or natural gas production, inject fluids used for enhanced recovery of oil or natural gas, or inject fluids for storage of liquid hydrocarbons? (FORM 4)				H. Do you or will you use at this facility fluids for special purposes such as enhanced recovery of sulfur by the Frasch process, in situ combustion, or in situ leaching for thermal energy? (FORM 4)			
I. Is this facility a proposed stationary source which is one of the 28 industrial categories listed in the instructions and which will potentially emit 100 tons per year of any air pollutant regulated under the Clean Air Act and may affect or be located in an attainment area? (FORM 5)				J. Is this facility a proposed stationary source which is NOT one of the 28 industrial categories listed in the instructions and which will potentially emit 250 tons per year of any air pollutant regulated under the Clean Air Act and may affect or be located in an attainment area? (FORM 5)			

III. NAME OF FACILITY

1 SKIP

IV. FACILITY CONTACT

A. NAME & TITLE (last, first, & title)

B. PHONE (area code & no.)

V. FACILITY MAILING ADDRESS

A. STREET OR P.O. BOX

B. CITY OR TOWN

C. STATE

D. ZIP CODE

VI. FACILITY LOCATION

A. STREET, ROUTE NO. OR OTHER SPECIFIC IDENTIFIER

B. COUNTY NAME

C. CITY OR TOWN

D. STATE

E. ZIP CODE

F. COUNTY CODE (if known)

CONTINUED FROM THE FRONT

VII. SIC CODES (4-digit, in order of priority)			
A. FIRST		D. SECOND	
C 7	(specify)	C 7	(specify)
C. THIRD		D. FOURTH	
C 7	(specify)	C 7	(specify)

VIII. OPERATOR INFORMATION	
A. NAME	B. Is the name listed in Item VIII-A also the owner?
C 8	<input type="checkbox"/> YES <input type="checkbox"/> NO

C. STATUS OF OPERATOR (Enter the appropriate letter into the answer box; if "Other", specify.)	D. PHONE (area code & no.)
F = FEDERAL S = STATE P = PRIVATE M = PUBLIC (other than federal or state) O = OTHER (specify)	C A

E. STREET OR P.O. BOX
C 26

F. CITY OR TOWN	G. STATE	H. ZIP CODE	IX. INDIAN LAND
C B			Is the facility located on Indian lands?
			<input type="checkbox"/> YES <input type="checkbox"/> NO

X. EXISTING ENVIRONMENTAL PERMITS			
A. NPDES (Discharges to Surface Water)		D. PSL (Air Emissions from Proposed Sources)	
C 9	N	C 9	P
B. UIC (Underground Injection of Fluids)		E. OTHER (specify)	
C 9	U	C 9	(specify)
C. RCRA (Hazardous Wastes)		E. OTHER (specify)	
C 9	R	C 9	(specify)

XI. MAP
 Attach to this application a topographic map of the area extending to at least one mile beyond property boundaries. The map must show the outline of the facility, the location of each of its existing and proposed intake and discharge structures, each of its hazardous waste treatment, storage, or disposal facilities, and each well where it injects fluids underground. Include all springs, rivers and other surface water bodies in the map area. See instructions for precise requirements.

XII. NATURE OF BUSINESS (provide a brief description)

XIII. CERTIFICATION (see instructions)
 I certify under penalty of law that I have personally examined and am familiar with the information submitted in this application and all attachments and that, based on my inquiry of those persons immediately responsible for obtaining the information contained in the application, I believe that the information is true, accurate and complete. I am aware that there are significant penalties for submitting false information, including the possibility of fine and imprisonment.

A. NAME & OFFICIAL TITLE (type or print)	B. SIGNATURE	C. DATE SIGNED
--	--------------	----------------

COMMENTS FOR OFFICIAL USE ONLY
C 15

Instructions.—Form 2b—Application for Permit To Discharge Wastewater

Concentrated Animal Feeding Operations and Aquatic Animal Production Facilities

This form must be completed by all applicants who check "yes" to item II-B in Form 1. Not all animal feeding operations or fish farms are required to obtain NPDES permits. Exclusions are based on size and occurrence of discharge. See the description of these statutory and regulatory exclusions the General Instructions which accompany Form 1. In particular, for animal feeding operations, the size cutoffs depend on whether or not pollutants are discharged through a man-made device or by direct contact with the facility or animals. A facility for laying hens or broilers is not required to have a permit unless it has a liquid manure handling system or continuous overflow watering. Also, facilities which discharge only in the case of a 25 year, 24 hour storm event are not required to have a permit.

For aquatic animal production facilities, the size cutoffs are based on whether the species are warm water or cold water, on the production weight per year in harvestable pounds, and on the amount of feeding in pounds of food (for cold water species). Also, facilities which discharge less than 30 days per year, or only during periods of excess runoff (for warm water fish) are not required to have a permit.

Item I-A. See the note above and the General Instructions which accompany Form 1 to be sure that your facility is "concentrated."

Item I-B. If your answer to item VI of Form 1 does not give a complete legal description of your facility's location, use this space to provide a complete description, such as quarter, section, township, and range.

Item I-C. Check "proposed" if your facility is not now in operation, or not now "concentrated" under the definition in the glossary found in the General Instructions which accompany Form 1.

Item II. Supply all information in item II if you checked (1) in item I-A.

Item II-A. Give the maximum number of each type of animal in open confinement or housed under roof (either partially or totally) which are held at your facility for a total of 45 days or more in any 12 month period.

Use the following categories for type of animals:

Slaughter Cattle; Feeder cattle;
Mature Dairy Cattle (milked or dry);
Swine (each weighing over 55 pounds);

Horses; Sheep; Lambs; Turkeys; Laying Hens; ¹Broilers; ¹Ducks.

Item II-B. Give only the area used for the animal confinement or feeding facility. Do not include any area used for growing or operating feed.

Item II-C. Check "yes" if any system for collection of runoff has been constructed. Supply the information under (1), (2), and (3) to the best of your knowledge.

Item III. Supply all information in item III if you checked (2) in item I-A.

Item III-A. Outfalls should be numbered to correspond with the map submitted in item XI of Form 1. Values given for flow should be representative of your normal operation. The maximum daily flow is the maximum measured flow occurring over a calendar day. The maximum 30-day flow is the average of measured daily flows over the calendar month of highest flow. The long-term average flow is the average of measured daily flows over a calendar year.

Item III-B. Give the total number of discrete ponds or raceways in your facility. Under "other," give a descriptive name of any structure which is not a pond or a raceway but which results in discharge to waters of the United States.

Item III-C. Use names for the receiving water and source of water which correspond to the map submitted in item XI of Form 1.

Item III-D. The names for fish species should be proper, common, or scientific names as given in special Publication No. 6 of the American Fisheries Society, "A List of Common and Scientific Names of Fishes from the United States and Canada." The values given for total weight produced by your facility per year and the maximum weight present at any one time should be representative of your normal operation.

Item III-E. The value given for maximum monthly pounds of food should be representative of your normal operation.

Item IV. The Clean Water Act provides for severe penalties for submitting false information on this application form.

Section 309(c)(2) of the Clean Water Act provides that "Any person who knowingly makes any false statement, representation, or certification in any application, . . . shall upon conviction, be punished by a fine of no more than \$10,000 or by imprisonment for not more than six months, or both."

Federal regulations require the certification to be signed as follows:

¹A permit is not required unless the facility has a liquid manure handling system or continuous overflow watering.

(1) For corporation, by a principal executive officer of at least the level of vice president;

(2) For a partnership or sole proprietorship, by a general partner or the proprietor, respectively; or

(3) For a municipality, State, Federal, or other public facility, by either a principal executive or ranking elected official.

BULLINC CODE 6560-01-M

EPA I.D. NUMBER (copy from Item 1 of Form 1)

Form Approved OMB No. 158-R0174

Please print or type in the unshaded areas only.

FORM 2B NPDES **EPA** U.S. ENVIRONMENTAL PROTECTION AGENCY
APPLICATION FOR PERMIT TO DISCHARGE WASTEWATER
CONCENTRATED ANIMAL FEEDING OPERATIONS AND AQUATIC ANIMAL PRODUCTION FACILITIES
Consolidated Permits Program

I. GENERAL INFORMATION

A. TYPE OF BUSINESS	B. LEGAL DESCRIPTION OF FACILITY LOCATION	C. FACILITY OPERATION STATUS
<input type="checkbox"/> 1. CONCENTRATED ANIMAL FEEDING OPERATION (complete Items B, C, and Section II) <input type="checkbox"/> 2. CONCENTRATED AQUATIC ANIMAL PRODUCTION FACILITY (complete Items B, C, and Section III)		<input type="checkbox"/> 1. EXISTING FACILITY <input type="checkbox"/> 2. PROPOSED FACILITY

II. CONCENTRATED ANIMAL FEEDING OPERATION CHARACTERISTICS

A. TYPE & NUMBER OF ANIMALS IN OPEN CONFINEMENT & HOUSED UNDER ROOF			B. NO. OF ACRES FOR CONFINEMENT FEEDING
1. TYPE	2. NO. IN OPEN CONFINEMENT	3. NO. HOUSED UNDER ROOF	C. If there is open confinement, has a runoff diversion and control system been constructed? <input type="checkbox"/> YES (complete Items 1, 2, & 3 below) <input type="checkbox"/> NO (go to Section IV)

1. What is the design basis for the control system?

<input type="checkbox"/> a. 10 YEAR, 24-HOUR STORM (specify inches)	INCHES	<input type="checkbox"/> b. 25 YEAR, 24-HOUR STORM (specify inches)	INCHES	<input type="checkbox"/> c. OTHER (specify inches & type)	INCHES	TYPE
---	--------	---	--------	---	--------	------

2. Report the number of acres of contributing drainage. **ACRES**

3. Report the design safety factor. **SAFETY FACTOR**

III. CONCENTRATED AQUATIC ANIMAL PRODUCTION FACILITY CHARACTERISTICS

A. For each outfall give the maximum daily flow, maximum 30 day flow, and the long term average flow.

1. OUTFALL NO.	2. FLOW (gallons per day)			3. OTHER
	B. MAXIMUM DAILY	D. MAXIMUM 30 DAY	C. LONG TERM AVERAGE	

B. Indicate the total number of ponds, raceways, and similar structures in your facility.

1. PONDS	2. RACEWAYS	3. OTHER

C. Provide the names of the receiving water and the source of water used by your facility.

1. RECEIVING WATER	2. WATER SOURCE

D. List the species of fish or aquatic animals held and fed at your facility. For each species, give the total weight produced by your facility per year in pounds of harvestable weight, and also give the maximum weight present at any one time.

1. COLD WATER SPECIES			2. WARM WATER SPECIES		
B. SPECIES	b. HARVESTABLE WEIGHT (pounds)		B. SPECIES	b. HARVESTABLE WEIGHT (pounds)	
	(1) TOTAL YEARLY	(2) MAXIMUM		(1) TOTAL YEARLY	(2) MAXIMUM

E. Report the total pounds of food fed during the calendar month of maximum feeding.

1. MONTH	2. POUNDS OF FOOD

IV. CERTIFICATION

I certify under penalty of law that I have personally examined and am familiar with the information submitted in this application and all attachments and that, based on my inquiry of those individuals immediately responsible for obtaining the information, I believe that the information is true, accurate and complete. I am aware that there are significant penalties for submitting false information, including the possibility of fine and imprisonment.

A. NAME & OFFICIAL TITLE (print or type)	B. PHONE NO. (area code & no.)
C. SIGNATURE	D. DATE SIGNED

EPA Form 3710-2B (5-80)
 BILLING CODE 6560-01-C

Instructions.—Form 2c—Application for Permit To Discharge Wastewater

Existing Manufacturing, Commercial, Mining, and Silvicultural Operations

This form must be completed by all applicants who check "yes" to item II-C in Form 1.

Public Availability of Submitted Information. Your application will not be considered complete unless you answer every question on this form and on Form 1. If an item does not apply to you, enter "NA" (for not applicable) to show that you considered the question.

You may not claim as confidential any information required by this form or Form 1, whether the information is reported on the forms or in an attachment. This information will be made available to the public upon request.

Any information you submit to EPA which goes beyond that required by this form and Form 1 you may claim as confidential, but claims for information which is effluent data will be denied. If you do not assert a claim of confidentiality at the time of submitting the information, EPA may make the information public without further notice to you. Claims of confidentiality will be handled in accordance with EPA's business confidentiality regulations at 40 CFR Part 2.

Definitions. All significant terms used in these instructions and in the form are defined in the glossary found in the General Instructions which accompany Form 1.

EPA I.D. Number. Fill in your EPA Identification Number at the top of each page of Form 2c. You may copy this number directly from item I of Form 1.

Item I. You may use the map you provided for item XI of Form 1 to determine the latitude and longitude of each of your outfalls and the name of the receiving water.

Item II-A. The line drawing should show generally the route taken by water in your facility from intake to discharge. Show all operations contributing wastewater, including process and production areas, sanitary flows, cooling water, and stormwater runoff. You may group similar operations into a single unit, labeled to correspond to the more detailed listing in item II-B. The water balance should show average flows. Show all significant losses of water to products, atmosphere, and discharge. You should use actual measurements whenever available; otherwise use your best estimate. An example of an acceptable line drawing appears in Figure 2c-1 to these instructions.

Item II-B. List all sources of wastewater to each outfall. Operations

may be described in general terms (for example, "dye-making reactor" or "distillation tower"). You may estimate the flow contributed by each source if no data is available, and for stormwater, you may use any reasonable measure of duration, volume, or frequency. For each treatment unit, indicate its size, flow rate, and retention time, and describe the ultimate disposal of any solid or liquid wastes not discharged. Treatment units should be listed in order and you should select the proper code from Table 2c-1 to fill in column 3-b for each treatment unit. Insert "XX" into column 3-b if no code corresponds to a treatment unit you list.

If you are applying for a permit for a privately owned treatment works, you must also identify all of your contributors in an attached listing.

BILLING CODE 6560-01-M

LINE DRAWING

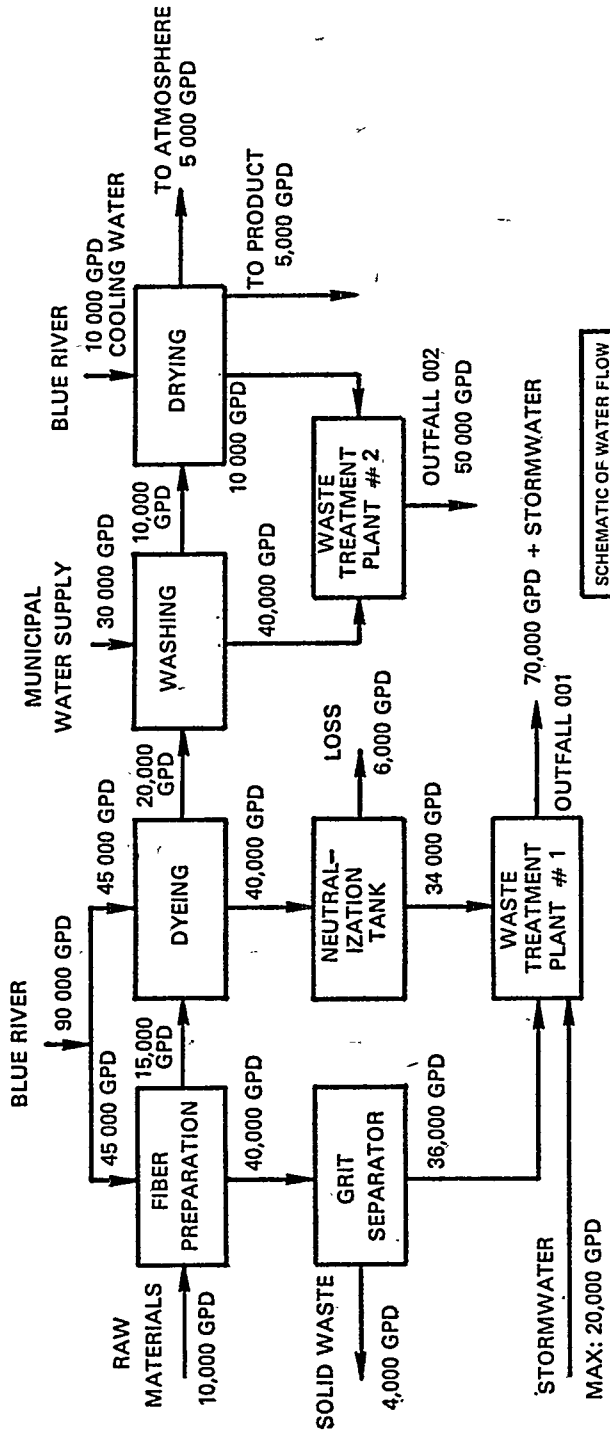

FIGURE 2c 1

BILLING CODE 6560-01-C

Table 2c-1.—Codes for Treatment Units

Physical Treatment Processes

- 1-A—Ammonia Stripping
- 1-B—Dialysis
- 1-C—Diatomaceous Earth Filtration
- 1-D—Distillation
- 1-E—Electrodialysis
- 1-F—Evaporation
- 1-G—Flocculation
- 1-H—Flotation
- 1-I—Foam Fractionation
- 1-J—Freezing
- 1-K—Gas-Phase Separation
- 1-L—Grinding (Comminutors)
- 1-M—Grit Removal
- 1-N—Microstraining
- 1-O—Mixing
- 1-P—Moving Bed Filters
- 1-Q—Multimedia Filtration
- 1-R—Rapid Sand Filtration
- 1-S—Reverse Osmosis (Hyperfiltration)
- 1-T—Screening
- 1-U—Sedimentation (Settling)
- 1-V—Slow Sand Filtration
- 1-W—Solvent Extraction
- 1-X—Sorption

Chemical Treatment Processes

- 2-A—Carbon Adsorption
- 2-B—Chemical Oxidation
- 2-C—Chemical Precipitation
- 2-D—Coagulation
- 2-E—Dechlorination
- 2-F—Disinfection (Chlorine)
- 2-G—Disinfection (Ozone)
- 2-H—Disinfection (Other)
- 2-I—Electrochemical Treatment
- 2-J—Ion Exchange
- 2-K—Neutralization
- 2-L—Reduction

Biological Treatment Processes

- 3-A—Activated Sludge
- 3-B—Aerated Lagoons
- 3-C—Anaerobic Treatment
- 3-D—Nitrification-Denitrification
- 3-E—Pre-Aeration
- 3-F—Spray Irrigation/Land Application
- 3-G—Stabilization Ponds
- 3-H—Trickling Filtration

Other Processes

- 4-A—Discharge to Surface Water
- 4-B—Ocean Discharge Through Outfall
- 4-C—Reuse/Recycle of Treated Effluent
- 4-D—Underground Injection

Sludge Treatment and Disposal Processes

- 5-A—Aerobic Digestion
- 5-B—Anaerobic Digestion
- 5-C—Belt Filtration
- 5-D—Centrifugation
- 5-E—Chemical Conditioning
- 5-F—Chlorine Treatment
- 5-G—Composting
- 5-H—Drying Beds
- 5-I—Elutriation
- 5-J—Flotation Thickening
- 5-K—Freezing
- 5-L—Gravity Thickening
- 5-M—Heat Drying
- 5-N—Heat Treatment
- 5-O—Incineration
- 5-P—Land Application
- 5-Q—Landfill
- 5-R—Pressure Filtration

- 5-S—Pyrolysis
- 5-T—Sludge Lagoons
- 5-U—Vacuum Filtration
- 5-V—Vibration
- 5-W—Wet Oxidation

Item II-C. A discharge is intermittent unless it occurs without interruption during the operating hours of the facility, except for infrequent shutdowns for maintenance, process changes, or other similar activities. A discharge is seasonal if it occurs only during certain parts of the year. Fill in every applicable column in this item for each source of intermittent or seasonal discharges. Base your answers on actual data whenever available; otherwise, provide your best estimate. Report the highest daily value for flow rate and total volume in the "Maximum Daily" columns (columns 4-a-2 and 4-b-2). Report the average of all daily values measured during days when discharge occurred within the last year in the "Long Term Average" columns (columns 4-a-1 and 4-b-1).

Item III-A. All effluent guidelines promulgated by EPA appear in the Federal Register and are published annually in 40 CFR Subchapter N. A guideline applies to you if you have any operations contributing process wastewater in any subcategory covered by a BPT, BCT, or BAT guideline. If you are unsure whether you are covered by a promulgated effluent guideline, check with your EPA Regional office (Table 1). You must check "yes" if an applicable effluent guideline has been promulgated, even if the guideline limitations are being contested in court. If you believe that a promulgated effluent guideline has been remanded for reconsideration by a court and does not apply to your operations, you may check "no."

Item III-B. An effluent guideline is expressed in terms of production (or other measure of operation) if the limitations are expressed as mass of pollutant per operational parameter; for example, "pounds of BOD per cubic foot of logs from which bark is removed," or "pounds of TSS per megawatt hour of electrical energy consumed by smelting furnace." An example of a guideline not expressed in terms of a measure of operation is one which limits the concentration of pollutants.

Item III-C. This item must be completed only if you checked "yes" to item III-B. The production information requested here is necessary to apply effluent guidelines to your facility and you may not claim it as confidential. However, you do not have to indicate how the reported information was calculated.

Report quantities in the units of measurement used in the applicable

effluent guideline. The figures provided must be a measure of actual operation over a one-month period, such as the production for the highest month during the last twelve months, or the monthly average production for the highest year of the last five years, or other reasonable measure of actual operation, but may not be based on design capacity or on predictions of future increases in operation.

Item IV-A. If you check "yes" to this question, complete all parts of the chart, or attach a copy of any previous submission you have made to EPA containing the same information.

Item IV-B. You are not required to submit a description of future pollution control projects if you do not wish to or if none is planned.

Item V-A, B, C, and D. These items require you to collect and report data on the pollutants discharged from each of your outfalls. Each part of this item addresses a different set of pollutants and must be completed in accordance with the specific instructions for that part. The following general instructions apply to the entire item.

General Instructions: Part A requires you to report at least one analysis for each pollutant listed. Parts B and C require you to report analytical data in two ways. For some pollutants, you may be required to mark "X" in the "Testing Required" column (column 2-a, Part C), and test (sample and analyze) and report the levels of the pollutants in your discharge whether or not you expect them to be present in your discharge. For all others, you must mark "X" in either the "Believe Present" column or the "Believe Absent" column (columns 2-a or 2-b, Part B, and columns 2-b or 2-c, Part C) based on your best estimate, and test for those which you believe to be present. Part D requires you to list any of a group of pollutants which you believe to be present, with a brief explanation of why you believe it to be present. (See specific instructions on the form and below for Parts A through D.)

Base your determination that a pollutant is present in or absent from your discharge on your knowledge of your raw materials, maintenance chemicals, intermediate and final products and byproducts, and any previous analyses known to you of your effluent or of any similar effluent. (For example, if you manufacture pesticides, you should expect those pesticides to be present in contaminated stormwater runoff.) If you would expect a pollutant to be present solely as a result of its presence in your intake water, you must mark "Believe Present" but you are not required to analyze for that pollutant.

Instead, mark an "X" in the "Intake" column.

a. **Reporting.** All levels must be reported as concentration and as total mass. You may report some or all of the required data by attaching separate sheets of paper instead of filling out pages V-1 to V-9 if the separate sheets contain all the required information in a format which is consistent with pages V-1 to V-9 in spacing and in identification of pollutants and columns. (For example, the data system used in your GC/MS analysis may be able to print data in the proper format.) Use the following abbreviations in the columns headed "Units" (column 3, Part A, and column 4, Parts B and C).

<i>Concentration</i>	<i>Mass</i>
ppm—parts per million	lbs—pounds
mg/l—milligrams per liter	ton—tons (English tons)
ppb—parts per billion	mg—milligrams
ug/l—micrograms per liter	g—grams
	kg—kilograms
	T—tonnes (metric tons)

If you measure only one daily value, complete only the "Maximum Daily Values" columns and insert "1" into the "Number of Analyses" columns (columns 2-a and 2-d, Part A, and columns 3-a and 3-d, Parts B and C). The permitting authority may require you to conduct additional analyses to further characterize your discharges. For composite samples, the daily value is the total mass or average concentration found in a composite sample taken over the operating hours of the facility during a 24-hour period; for grab samples, the daily value is the arithmetic or flow-weighted total mass or average concentration found in a series of at least four grab samples taken over the operating hours of the facility during a 24-hour period.

If you measure more than one daily value for a pollutant, determine the average of all values within the last year and report the concentration and mass under the "Long-term Average Values" columns (column 2-c, Part A, and column 3-c, Parts B and C), and the total number of daily values under the "Number of Analyses" columns (column 2-d, Part A, and column 3-d, Parts B and C). Also, determine the average of all daily values taken during each calendar month, and report the highest average under the "Maximum 30-day Values" columns (column 2-c, Part A, and column 3-b, Parts B and C).

a. **Sampling:** The collection of the samples for the reported analyses should be supervised by a person experienced in performing sampling of industrial wastewater. You may contact your EPA or State permitting authority for detailed guidance on sampling techniques and for answers to specific

questions. Any specific requirements contained in the applicable analytical methods should be followed for sample containers, sample preservation, holding times, the collection of duplicate samples, etc. The time when you sample should be representative of your normal operation, to the extent feasible, with all processes which contribute wastewater in normal operation, and with your treatment system operating properly with no system upsets. Samples should be collected from the center of the flow channel, where turbulence is at a maximum, at a site specified in your present permit, or at any site adequate for the collection of a representative sample.

Grab and composite samples are defined as follows:

Grab sample: An individual sample of at least 100 milliliters collected at a randomly-selected time over a period not exceeding 15 minutes.

Composite sample: A combination of at least 8 sample aliquots of at least 100 milliliters, collected at periodic intervals during the operating hours of a facility over a 24 hour period. For volatile pollutants, aliquots must be combined in the laboratory immediately before analysis. The composite must be flow proportional; either the time interval between each aliquot or the volume of each aliquot must be proportional to either the stream flow at the time of sampling or the total stream flow since the collection of the previous aliquot. Aliquots may be collected manually or automatically.

c. **Analysis:** You must use test methods promulgated in 40 CFR Part 136; however, if none has been promulgated for a particular pollutant, you may use any suitable method for measuring the level of the pollutant in your discharge provided that you submit a description of the method or a reference to a published method. Your description should include the sample holding times, preservation techniques, and the quality control measures which you used. If you have two or more substantially identical outfalls, you may request permission from your permitting authority to sample and analyze only one outfall and submit the results of the analysis for other substantially identical outfalls. If your request is granted by the permitting authority, on a separate sheet attached to the application form identify which outfall you did test, and describe why the outfalls which you did not test are substantially identical to the outfall which you did test.

d. **Reporting of Intake Data:** You are not required to report data under the "Intake" columns unless you wish to demonstrate your eligibility for a "net"

effluent limitation for one or more pollutants, that is, an effluent limitation adjusted by subtracting the average level of the pollutant(s) present in your intake water. NPDES regulations allow net limitations only in certain circumstances. To demonstrate your eligibility, under the "Intake" columns report the average of the results of analyses on your intake water (if your water is treated before use, test the water after it is treated), and attach a separate sheet containing the following for each pollutant:

1. A statement that the intake water is drawn from the body of water into which the discharge is made. (Otherwise, you are not eligible for net limitations.)

2. A statement of the extent to which the level of the pollutant is reduced by treatment of your wastewater. (Your limitations will be adjusted only to the extent that the pollutant is not removed.)

3. When applicable (for example, when the pollutant represents a class of compounds), a demonstration of the extent to which the pollutants in the intake vary physically, chemically, or biologically from the pollutants contained in your discharge. (Your limitations will be adjusted only to the extent that the intake pollutants do not vary from the discharged pollutants.)

Part V-A. Part V-A must be completed by all applicants for all outfalls, including outfalls containing only noncontact cooling water or storm runoff. However, at your request, the permitting authority may waive the requirements to test for one or more of these pollutants, upon a determination that testing for the pollutant(s) is not appropriate for your effluents.

Use composite samples for all pollutants in this Part, except use grab samples for pH and temperature. See discussion in General Instructions to item V for definitions of the columns in Part A. The "Long Term Average Values" column (column 2-c) and "Maximum 30-day Values" column (column 2-b) are not compulsory but should be filled out if data is available.

Part V-B. Part V-B must be completed by all applicants for all outfalls, including outfalls containing only noncontact cooling water or storm runoff.

Use composite samples for all pollutants you analyze for in this Part, except use grab samples for residual chlorine, oil and grease, and fecal coliform. The "Long-term Average Values" column (column 3-c) and "Maximum 30-day Values" column (column 3-b) are not compulsory but should be filled out if data is available.

Part V-C. Table 2c-2 lists the 34 "primary" industry categories in the left-hand column. For each outfall, if any of your processes which contribute wastewater falls into one of those categories, you must mark "X" in "Testing Required" column (column 2-a) and test for (1) all of the toxic metals, cyanide, and total phenols, and (2) the organic toxic pollutants contained in the gas chromatography/mass spectrometry (GC/MS) fractions indicated in Table 2c-2 as applicable to your category, unless you qualify as a small business (see below). The organic toxic pollutants are listed by GC/MS fractions on pages V-4 to V-9 in Part V-C. For example, the Organic Chemicals Industry has an asterisk in all four fractions; therefore, applicants in this category must test for all organic toxic pollutants in Part V-C. If you are applying for a permit for a privately owned treatment works, determine your testing requirements on the basis of the industry categories of your contributors. When you determine which industry category you are in to find your testing requirements, you are not determining your category for any other purpose and you are not giving up your right to challenge your inclusion in that category (for example, for deciding whether an effluent guideline is applicable) before your permit is issued.

For all other cases (secondary industries, non-process wastewater outfalls, and non-required GC/MS fractions), you must mark "X" in either the "Believed Present" column (column 2-b) or the "Believed Absent" column (column 2-c) for each pollutant, and test for those you believe present (those marked "X" in column 2-b). If you qualify as a small business (see below) you are exempt from testing for the organic toxic pollutants, listed on pages V-4 to V-9 in Part C. For pollutants in intake water, see discussion in General Instructions to this item. The "Long-term Average Values" column (column 3-c) and "Maximum 30-day Values" column (column 3-b) are not compulsory but should be filled out if data is available.

Use composite samples for all pollutants in this Part, except use grab samples for total phenols and cyanide.

Table 2c-2.—Testing Requirements for Organic Toxic Pollutants by Industry Category

Industry category	GC/MS fraction ¹			
	Volatile	Acid	Base/ Pesti- neutral	code
Adhesives and sealants.....	(*)	(*)	(*)	-----
Aluminum forming.....	(*)	(*)	(*)	-----
Auto and other laundries.....	(*)	(*)	(*)	(*)
Battery manufacturing.....	(*)	-----	(*)	-----
Coal mining.....	(*)	(*)	(*)	(*)
Coil coating.....	(*)	(*)	(*)	-----
Copper forming.....	(*)	(*)	(*)	-----

Table 2c-2.—Testing Requirements for Organic Toxic Pollutants by Industry Category—Continued

Industry category	GC/MS fraction ¹			
	Volatile	Acid	Base/ Pesti- neutral	code
Electric and electronic compounds.....	(*)	(*)	(*)	(*)
Electroplating.....	(*)	(*)	(*)	-----
Explosives manufacturing.....	(*)	(*)	(*)	-----
Foundries.....	(*)	(*)	(*)	-----
Gum and wood chemicals.....	(*)	(*)	(*)	(*)
Inorganic chemicals manufacturing.....	(*)	(*)	(*)	-----
Iron and steel manufacturing.....	(*)	(*)	(*)	-----
Leather tanning and finishing.....	(*)	(*)	(*)	(*)
Mechanical products manufacturing.....	(*)	(*)	(*)	-----
Nonferrous metals manufacturing.....	(*)	(*)	(*)	(*)
Ore mining.....	(*)	(*)	(*)	(*)
Organic chemicals manufacturing.....	(*)	(*)	(*)	(*)
Paint and ink formulation.....	(*)	(*)	(*)	(*)
Pesticides.....	(*)	(*)	(*)	(*)
Petroleum refining.....	(*)	(*)	(*)	(*)
Pharmaceutical preparations.....	(*)	(*)	(*)	-----
Photographic equipment and supplies.....	(*)	(*)	(*)	(*)
Plastic and synthetic materials manufacturing.....	(*)	(*)	(*)	(*)
Plastic processing.....	(*)	-----	(*)	(*)
Porcelain enameling.....	(*)	-----	(*)	(*)
Printing and publishing.....	(*)	(*)	(*)	(*)
Pulp and paperboard mills.....	(*)	(*)	(*)	(*)
Rubber processing.....	(*)	(*)	(*)	(*)
Soap and detergent manufacturing.....	(*)	(*)	(*)	-----
Steam electric power plants.....	(*)	(*)	(*)	-----
Textile mills.....	(*)	(*)	(*)	(*)
Timber products processing.....	(*)	(*)	(*)	(*)

¹The pollutants in each fraction are listed in item V-C.
* Testing required.

You are required to mark "Testing Required" for dioxin if you use or manufacture one of the following compounds: (a) 2,4,5-trichlorophenoxy acetic acid, (2,4,5-T); (b) 2-(2,4,5-trichlorophenoxy) propanoic acid, (Silvex, 2,4,5-TP); (c) 2-(2,4,5-trichlorophenoxy) ethyl 2,2-dichloropropionate, (Erbon); (d) O,O-dimethyl O-(2,4,5-trichlorophenyl) phosphorothioate, (Ronnel); (e) 2,4,5-trichlorophenol, (TCP); or (f) hexachlorophene, (HCP). If you mark "Testing Required" or "Believe Present," you must perform a screening analysis for dioxins, using gas chromatography with an electron capture detector. A TCDD standard for quantitation is not required. Describe the results of this analysis in the space provided; for example, "no measurable baseline deflection at the retention time of TCDD" or "a measurable peak within the tolerances of the retention time of TCDD." The permitting authority may require you to perform a quantitative analysis if you report a positive result.

The Effluent Guidelines Division of EPA has collected and analyzed samples from some plants for the pollutants listed in Part C in the course of its BAT guidelines development program. If your effluents were sampled

and analyzed as part of this program in the last three years, you may use this data to answer Part C provided that the permitting authority approves, and provided that no process change or change in raw materials or operating practices has occurred since the samples were taken that would make the analyses unrepresentative of your current discharge.

Small Business Exemption. If you qualify as a "small business," you are exempt from the reporting requirements for the organic toxic pollutants, listed on pages V-4 to V-9 in Part C. If your facility is a coal mine, and if your probable total annual production is less than 100,000 tons per year, you may submit past production data or estimated future production (such as a schedule of estimated total production under 30 CFR § 795.14(c)) instead of conducting analyses for the organic toxic pollutants. If your facility is not a coal mine, and if your gross total annual sales for the most recent three years average less than \$100,000 per year (in second quarter 1980 dollars), you may submit sales data for those years instead of conducting analyses for the organic toxic pollutants.

The production or sales data must be for the facility which is the source of the discharge. The data should not be limited to production or sales for the process or processes which contribute to the discharge, unless those are the only processes at your facility. For sales data, in situations involving intra-corporate transfers of goods and services, the transfer price per unit should approximate market prices for those goods and services as closely as possible. Sales figures for years after 1980 should be indexed to the second quarter of 1980 by using the gross national product price deflator (second quarter of 1980=100). This index is available in *National Income and Product Accounts of the United States* (Department of Commerce, Bureau of Economic Analysis).

Part V-D. List any pollutants in Table 2c-3 that you believe to be present and explain why you believe them to be present. No analysis is required, but if you have analytical data, you must report it.

Note: Under 40 CFR 117.12(a)(2), certain discharges of hazardous substances (listed in Table 2c-4 of these instructions) may be exempted from the requirements of section 311 of CWA, which establishes reporting requirements, civil penalties, and liability for clean-up costs for spills of oil and hazardous substances. A discharge of a particular substance may be exempted if the origin, source and

amount of the discharged substance are identified in the NPDES permit application or in the permit, if the permit contains a requirement for treatment of the discharge, and if the treatment is in place. To apply for an exclusion of the discharge of any hazardous substance from the requirements of section 311, attach additional sheets of paper to your form, setting forth the following information:

1. The substance and the amount of each substance which may be discharged.

2. The origin and source of the discharge of the substance.

3. The treatment which is to be provided for the discharge by:

a. An on-site treatment system separate from any treatment system treating your normal discharge;

b. A treatment system designed to treat your normal discharge and which is additionally capable of treating the amount of the substance identified under paragraph 1 above; or

c. Any combination of the above.

See 40 CFR § 117.12(a)(2) and (c), published on August 29, 1979, in 44 FR 50766, or contact your Regional office (Table 1), for further information on exclusions from section 311.

Table 2c-3.—Toxic Pollutants and Hazardous Substances Required to be Identified by Applicants If Expected to be Present

Toxic Pollutants

Asbestos

Hazardous Substances

Acetaldehyde
 Allyl alcohol
 Allyl chloride
 Amyl acetate
 Aniline
 Benzonitrile
 Benzyl chloride
 Butyl acetate
 Butylamine
 Captan
 Carbaryl
 Carbofuran
 Carbon disulfide
 Chlorpyrifos
 Coumaphos
 Cresol
 Crotonaldehyde
 Cyclohexane
 2,4-D (2,4-Dichlorophenoxyacetic acid)
 Diazinon
 Dicamba
 Dichlobenil
 Dichlone
 2,2-Dichloropropionic acid
 Dichlorvos
 Diethyl amine
 Dimethyl amine
 Dinitrobenzene
 Diquat
 Disulfoton
 Diuron
 Epichlorohydrin

Ethanolamine
 Ethion
 Ethylene diamine
 Ethylene dibromide
 Formaldehyde
 Furfural
 Guthion
 Isoprene
 Isopropanolamine
 Kelthane
 Kepone
 Malathion
 Mercaptodimethur
 Methoxychlor
 Methyl mercaptan
 Methyl methacrylate
 Methyl parathion
 Mevinphos
 Mexacarbate
 Monoethyl amine
 Monomethyl amine
 Naled
 Naphtenic acid
 Nitrotoluene
 Parathion
 Phenolsulfonate
 Phosgene
 Propargite
 Propylene oxide
 Pyrethrins
 Quinoline
 Resorcinol
 Strontium
 Strychnine
 Styrene
 2,4,5-T (2,4,5-Trichlorophenoxyacetic acid)
 TDE (Tetrachlorodiphenyl ethane)
 2,4,5-TP [2-(2,4,5-Trichlorophenoxy) propanoic acid]
 Trichlorofon
 Triethylamine
 Trimethylamine
 Uranium
 Vanadium
 Vinyl acetate
 Xylene
 Xylenol
 Zirconium

Item VI-A. You may not claim this information as confidential; however, you do not have to distinguish between use or production of the pollutants or list the amounts. Under NPDES regulations your permit will contain limits to control all pollutants you report in answer to this question, as well as all pollutants reported in item V or VI-B at levels exceeding the technology-based limits appropriate to your facility. Your permit will also require you to report to EPA if you in the future begin or expect that you will begin to use or manufacture as an intermediate or final product or byproduct any toxic pollutant which you did not report here, and your permit may be modified at that time if necessary to control that pollutant.

Item VI-B. For this item, consider only those variations which may result in concentrations of pollutants in effluents which may exceed two times the maximum values you reported in item V. These variations may be part of your

routine operations, or part of your regular cleaning cycles.

Under NPDES regulations your permit will contain limits to control any pollutant you report in answer to this question at levels exceeding the technology-based limits appropriate to your facility. Your permit will also require you to report to EPA if you know or have reason to believe that any activity has occurred or will occur which would make your discharge of any toxic pollutant five times the maximum values reported in item V-C or in this item, and your permit may be modified at that time if necessary to control the pollutant.

Do not consider variations which are the result of bypasses or upsets. Increased levels of pollutants which are discharged as a result of bypasses or upsets are regulated separately under NPDES regulations.

Item VI-C. Examples of the types of variations to be described here include:

- Changes in raw or intermediate materials;
- Changes in process equipment or materials;
- Changes in product lines;
- Significant chemical reactions between pollutants in waste streams; and

Significant variation in removal efficiencies of pollution control equipment.

You may indicate other types of variations as well, except those which are the result of bypasses or upsets. The permitting authority may require you to further investigate or document variations you report here.

Base your prediction of expected levels of these pollutants upon your knowledge of your processes, raw materials, past and projected product ranges, etc., or upon any testing conducted upon your effluents which indicates the range of variability that can be expected in your effluent over the next five years.

Example: Outfall 001 discharges water used to clean six 500-gallon tanks. These tanks are used for formulation of dispersions of synthetic resins in water (adhesives). Use of toxic pollutants which can be expected in the next 5 years is:

1. Copper acetate inhibitor, ½ lb. per tank
2. Dibutyl phthalate, 50 lbs. per tank
3. Toulene, 5 lbs. per tank
4. Antimony oxide, 1 lb. per tank.

Based on normal cleaning, an average of 1% and a maximum of 3% of the contents of each tank is collected and discharged once every two weeks in the 150 gallons of water used for cleaning. Treatment (pH adjustment, flocculation,

filtration) removes 85% of metals and 50% of organic compounds.

Item VII. Self explanatory. The permitting authority may ask you to provide additional details after your application is received.

Item VIII. Self explanatory.

Item IX. The Clean Water Act provides for severe penalties for submitting false information on this application form.

Section 309(c)(2) of the Clean Water Act provides that "Any person who knowingly makes any false statement, representation, or certification in any application, . . . shall upon conviction, be punished by a fine of no more than \$10,000 or by imprisonment for not more than six months, or both."

Federal Regulations Require the Certification To Be Signed as Follows:

(1) For a corporation, by a principal executive officer of at least the level of vice president;

(2) For a partnership or sole proprietorship, by a general partner or the proprietor, respectively; or

(3) For a municipality, State, Federal, or other public facility, by either a principal executive officer or ranking elected official.

Table 2c-4.—Hazardous Substances

- | | | |
|-----------------------------|---|--|
| 1. Acetaldehyde | 40. Antimony potassium tartrate | 114. Dichloropropene-dichloropropane mix |
| 2. Acetic acid | 41. Antimony tribromide | 115. 2,2 Dichloropropionic acid |
| 3. Acetic anhydride | 42. Antimony trichloride | 116. Dichlorvos |
| 4. Acetone cyanohydrin | 43. Antimony trifluoride | 117. Dieldrin |
| 5. Acetyl bromide | 44. Antimony trioxide | 118. Diethylamine |
| 6. Acetyl chloride | 45. Arsenic disulfide | 119. Dimethylamine |
| 7. Acrolein | 46. Arsenic pentoxide | 120. Dinitrobenzene |
| 8. Acrylonitrile | 47. Arsenic trichloride | 121. Dinitrophenol |
| 9. Adipic acid | 48. Arsenic trioxide | 122. Dinitrotoluene |
| 10. Aldrin | 49. Arsenic trisulfide | 123. Diquat |
| 11. Allyl alcohol | 50. Barium cyanide | 124. Disulfoton |
| 12. Allyl chloride | 51. Benzene | 125. Diuron |
| 13. Aluminum sulfate | 52. Benzoic acid | 126. Dodecylbenzenesulfonic acid |
| 14. Ammonia | 53. Benzonitrile | 127. Endosulfan |
| 15. Ammonium acetate | 54. Benzoyl chloride | 128. Endrin |
| 16. Ammonium benzoate | 55. Benzyl chloride | 129. Epichlorohydrin |
| 17. Ammonium bicarbonate | 56. Beryllium chloride | 130. Ethion |
| 18. Ammonium bichromate | 57. Beryllium fluoride | 131. Ethylbenzene |
| 19. Ammonium bifluoride | 58. Beryllium nitrate | 132. Ethylenediamine |
| 20. Ammonium bisulfite | 59. Butylacetate | 133. Ethylene dibromide |
| 21. Ammonium carbamate | 60. n-Butylphthalate | 134. Ethylene dichloride |
| 22. Ammonium carbonate | 61. Butylaniline | 135. Ethylene diaminetetracetic acid
(EDTA) |
| 23. Ammonium chloride | 62. Butyric acid | 136. Ferric ammonium citrate |
| 24. Ammonium chromate | 63. Cadmium acetate | 137. Ferric ammonium oxalate |
| 25. Ammonium citrate | 64. Cadmium bromide | 138. Ferric chloride |
| 26. Ammonium fluoroborate | 65. Cadmium chloride | 139. Ferric fluoride |
| 27. Ammonium fluoride | 66. Calcium arsenate | 140. Ferric nitrate |
| 28. Ammonium hydroxide | 67. Calcium arsenite | 141. Ferric sulfate |
| 29. Ammonium oxalate | 68. Calcium carbide | 142. Ferrous ammonium sulfate |
| 30. Ammonium silicofluoride | 69. Calcium chromate | 143. Ferrous chloride |
| 31. Ammonium sulfamate | 70. Calcium cyanide | 144. Ferrous sulfate |
| 32. Ammonium sulfide | 71. Calcium dodecylbenzenesulfonate | 145. Formaldehyde |
| 33. Ammonium sulfite | 72. Calcium hypochlorite | 146. Formic acid |
| 34. Ammonium tartrate | 73. Captan | 147. Fumaric acid |
| 35. Ammonium thiocyanate | 74. Carbaryl | 148. Furfural |
| 36. Ammonium thiosulfate | 75. Carbofuran | 149. Guthion |
| 37. Amyl acetate | 76. Carbon disulfide | 150. Heptachlor |
| 38. Aniline | 77. Carbon tetrachloride | 151. Hexachlorocyclopentadiene |
| 39. Antimony pentachloride | 78. Chlordane | 152. Hydrochloric acid |
| | 79. Chlorine | 153. Hydrofluoric acid |
| | 80. Chlorobenzene | 154. Hydrogen cyanide |
| | 81. Chloroform | 155. Hydrogen sulfite |
| | 82. Chloropyrifos | 156. Isoprene |
| | 83. Chlorosulfonic acid | 157. Isopropanolamine
dodecylbenzenesulfonate |
| | 84. Chromic acetate | 158. Kelthane |
| | 85. Chromic acid | 159. Kepone |
| | 86. Chromic sulfate | 160. Lead acetate |
| | 87. Chromous chloride | 161. Lead arsenate |
| | 88. Cobaltous bromide | 162. Lead chloride |
| | 89. Cobaltous formate | 163. Lead fluoborate |
| | 90. Cobaltous sulfamate | 164. Lead flourite |
| | 91. Coumaphos | 165. Lead iodide |
| | 92. Cresol | 166. Lead nitrate |
| | 93. Crotonaldehyde | 167. Lead stearate |
| | 94. Cupric acetate | 168. Lead sulfate |
| | 95. Cupric acetoarsenite | 169. Lead sulfide |
| | 96. Cupric chloride | 170. Lead thiocyanate |
| | 97. Cupric nitrate | 171. Lindane |
| | 98. Cupric oxalate | 172. Lithium chromate |
| | 99. Cupric sulfate | 173. Malathion |
| | 100. Cupric sulfate ammoniated | 174. Maleic acid |
| | 101. Cupric tartrate | 175. Maleic anhydride |
| | 102. Cyanogen chloride | 176. Mercaptodimethur |
| | 103. Cyclohexane | 177. Mercuric cyanide |
| | 104. 2,4-D acid (2,4-Dichlorophenoxyacetic acid) | 178. Mercuric nitrate |
| | 105. 2,4-D esters (2,4-Dichlorophenoxyacetic acid esters) | 179. Mercuric sulfate |
| | 106. DDT | 180. Mercuric thiocyanate |
| | 107. Diazinon | 181. Mercurous nitrate |
| | 108. Dicamba | 182. Methoxychlor |
| | 109. Dichlobenil | 183. Methyl mercaptan |
| | 110. Dichlone | 184. Methyl methacrylate |
| | 111. Dichlorobenzene | 185. Methyl parathion |
| | 112. Dichloropropane | 186. Mevinphos |
| | 113. Dichloropropene | 187. Mexacarbate |

- | | |
|--|---------------------------------------|
| 188. Monoethylamine | 259. TDE (Tetrachlorodiphenyl ethane) |
| 189. Monomethylamine | 260. Tetraethyl lead |
| 190. Naled | 261. Tetraethyl pyrophosphate |
| 191. Napthalene | 262. Thallium sulfate |
| 192. Napthenic acid | 263. Toluene |
| 193. Nickel ammonium sulfate | 264. Toxaphene |
| 194. Nickel chloride | 265. Trichlorofon |
| 195. Nickel hydroxide | 266. Trichloroethylene |
| 196. Nickel nitrate | 267. Trichlorophenol |
| 197. Nickel sulfate | 268. Triethanolamine |
| 198. Nitric acid | dodecylbenzenesulfonate |
| 199. Nitrobenzene | 269. Triethylamine |
| 200. Nitrogen dioxide | 270. Trimethylamine |
| 201. Nitrophenol | 271. Uranyl acetate |
| 202. Nitrotoluene | 272. Uranyl nitrate |
| 203. Paraformaldehyde | 273. Vanadium pentoxide |
| 204. Parathion | 274. Vanadyl sulfate |
| 205. Pentachlorophenol | 275. Vinyl acetate |
| 206. Phenol | 276. Vinylidene chloride |
| 207. Phosgene | 277. Xylene |
| 208. Phosphoric acid | 278. Xylenol |
| 209. Phosphorus | 279. Zinc acetate |
| 210. Phosphorus oxychloride | 280. Zinc ammonium chloride |
| 211. Phosphorus pentasulfide | 281. Zinc borate |
| 212. Phosphorus trichloride | 282. Zinc bromide |
| 213. Polychlorinated biphenyls (PCB) | 283. Zinc carbonate |
| 214. Potassium arsenate | 284. Zinc chloride |
| 215. Potassium arsenite | 285. Zinc cyanide |
| 216. Potassium bichromate | 286. Zinc fluoride |
| 217. Potassium chromate | 287. Zinc formate |
| 218. Potassium cyanide | 288. Zinc hydrosulfonate |
| 219. Potassium hydroxide | 289. Zinc nitrate |
| 220. Potassium permanganate | 290. Zinc phenolsulfonate |
| 221. Propargite | 291. Zinc phosphide |
| 222. Propionic acid | 292. Zinc silicofluoride |
| 223. Propionic anhydride | 293. Zinc sulfate |
| 224. Propylene oxide | 294. Zirconium nitrate |
| 225. Pyrethrins | 295. Zirconium potassium flouride |
| 226. Quinoline | 296. Zirconium sulfate |
| 227. Resorcinol | 297. Zirconium tetrachloride |
| 228. Selenium oxide | |
| 229. Silver nitrate | BILLING CODE 6560-01-M |
| 230. Sodium | |
| 231. Sodium arsenate | |
| 232. Sodium arsenite | |
| 233. Sodium bichromate | |
| 234. Sodium bifluoride | |
| 235. Sodium bisulfite | |
| 236. Sodium chromate | |
| 237. Sodium cyanide | |
| 238. Sodium dodecylbenzenesulfonate | |
| 239. Sodium fluoride | |
| 240. Sodium hydrosulfide | |
| 241. Sodium hydroxide | |
| 242. Sodium hypochlorite | |
| 243. Sodium methylate | |
| 244. Sodium nitrite | |
| 245. Sodium phosphate (dibasic) | |
| 246. Sodium phosphate (tribasic) | |
| 247. Sodium selenite | |
| 248. Strontium chromate | |
| 249. Strychnine | |
| 250. Styrene | |
| 251. Sulfuric acid | |
| 252. Sulfur monochloride | |
| 253. 2,4,5-T acid (2,4,5-Trichlorophenoxyacetic acid) | |
| 254. 2,4,5-T amines (2,4,5-Trichlorophenoxy acetic acid amines) | |
| 255. 2,4,5-T esters (2,4,5-Trichlorophenoxy acetic acid esters) | |
| 256. 2,4,5-T salts (2,4,5-Trichlorophenoxy acetic acid salts) | |
| 257. 2,4,5-TP acid (2,4,5-Trichlorophenoxy propanoic acid) | |
| 258. 2,4,5-TP acid esters (2,4,5-Trichlorophenoxy propanoic acid esters) | |

CONTINUED FROM THE FRONT

C. Except for storm runoff, leaks, or spills, are any of the discharges described in Items II-A or B intermittent or seasonal?

YES (complete the following table) NO (go to Section III)

1. OUTFALL NUMBER (list)	2. OPERATION(S) CONTRIBUTING FLOW (list)	3. FREQUENCY		4. FLOW				5. DURATION (in days)
		a. DAYS PER WEEK (specify average)	b. MONTHS PER YEAR (specify average)	a. FLOW RATE (in mgd)		b. TOTAL VOLUME (specify with units)		
				1. LONG TERM AVERAGE	2. MAXIMUM DAILY	1. LONG TERM AVERAGE	2. MAXIMUM DAILY	

III. MAXIMUM PRODUCTION

A. Does an effluent guideline limitation promulgated by EPA under Section 304 of the Clean Water Act apply to your facility?

YES (complete Item III-B) NO (to Section IV)

B. Are the limitations in the applicable effluent guideline expressed in terms of production (or other measure of operation)?

YES (complete Item III-C) NO (go to Section IV)

C. If you answered "Yes" to Item III-B, list the quantity which represents an actual measurement of your maximum level of production, expressed in the terms and units used in the applicable effluent guideline, and indicate the affected outfalls.

1. MAXIMUM QUANTITY			2. AFFECTED OUTFALLS (list outfall numbers)
a. QUANTITY PER DAY	b. UNITS OF MEASURE	c. OPERATION, PRODUCT, MATERIAL, ETC. (specify)	

IV. IMPROVEMENTS

A. Are you now required by any Federal, State or local authority to meet any implementation schedule for the construction, upgrading or operation of wastewater treatment equipment or practices or any other environmental programs which may affect the discharges described in this application? This includes, but is not limited to, permit conditions, administrative or enforcement orders, enforcement compliance schedule letters, stipulations, court orders, and grant or loan conditions.

YES (complete the following table) NO (go to Item IV-B)

1. IDENTIFICATION OF CONDITION, AGREEMENT, ETC.	2. AFFECTED OUTFALLS		3. BRIEF DESCRIPTION OF PROJECT	4. FINAL COMPLIANCE DATE	
	a. NO.	b. SOURCE OF DISCHARGE		a. REQUIRED	b. PROJECTED

B. OPTIONAL: You may attach additional sheets describing any additional water pollution control programs (or other environmental projects which may affect your discharges) you now have underway or which you plan. Indicate whether each program is now underway or planned, and indicate your actual or planned schedules for construction. MARK "X" IF DESCRIPTION OF ADDITIONAL CONTROL PROGRAMS IS ATTACHED

EPA I.D. NUMBER (copy from Item 1 of Form 1)

Form Approved OMB No. 158-R0173

CONTINUED FROM PAGE 2

V. INTAKE AND EFFLUENT CHARACTERISTICS

A, B, & C: See instructions before proceeding — Complete one set of tables for each outfall — Annotate the outfall number in the space provided.
 NOTE: Tables V-A, V-B, and V-C are included on separate sheets numbered V-1 through V-9.

D. Use the space below to list any of the pollutants listed in Table 2c-3 of the instructions, which you know or have reason to believe is discharged or may be discharged from any outfall. For every pollutant you list, briefly describe the reasons you believe it to be present and report any analytical data in your possession.

1. POLLUTANT	2. SOURCE	1. POLLUTANT	2. SOURCE

FACSIMILE

VI. POTENTIAL DISCHARGES NOT COVERED BY ANALYSIS

A. Is any pollutant listed in Item V-C a substance or a component of a substance which you do or expect that you will over the next 5 years use or manufacture as an intermediate or final product or byproduct?

YES (list all such pollutants below) NO (go to Item VI-B)

B. Are your operations such that your raw materials, processes, or products can reasonably be expected to vary so that your discharges of pollutants may during the next 5 years exceed two times the maximum values reported in Item V?

YES (complete Item VI-C below) NO (go to Section VII)

C. If you answered "Yes" to Item VI-B, explain below and describe in detail the sources and expected levels of such pollutants which you anticipate will be discharged from each outfall over the next 5 years, to the best of your ability at this time. Continue on additional sheets if you need more space.

CONTINUED FROM THE FRONT

VII. BIOLOGICAL TOXICITY TESTING DATA

Do you have any knowledge or reason to believe that any biological test for acute or chronic toxicity has been made on any of your discharges or on a receiving water in relation to your discharge within the last 3 years?

YES (Identify the test(s) and describe their purposes below)

NO (go to Section VIII)

FACSIMILE

VIII. CONTRACT ANALYSIS INFORMATION

Were any of the analyses reported in Item V performed by a contract laboratory or consulting firm?

YES (list the name, address, and telephone number of, and pollutants analyzed by, each such laboratory or firm below)

NO (go to Section IX)

A. NAME	B. ADDRESS	C. TELEPHONE (area code & no.)	D. POLLUTANTS ANALYZED (list)

IX. CERTIFICATION

I certify under penalty of law that I have personally examined and am familiar with the information submitted in this application and all attachments and that, based on my inquiry of those individuals immediately responsible for obtaining the information, I believe that the information is true, accurate and complete. I am aware that there are significant penalties for submitting false information, including the possibility of fine and imprisonment.

A. NAME & OFFICIAL TITLE (type or print)	B. PHONE NO. (area code & no.)
C. SIGNATURE	D. DATE SIGNED

EPA I.D. NUMBER (copy from Item 1 of Form 1)

Form Approved OMB No. 158-R0173

OUTFALL NO.

PLEASE PRINT OR TYPE IN THE UNSHADED AREAS ONLY. You may report some or all of this information on separate sheets (use the same format) instead of completing these pages. SEE INSTRUCTIONS.

V. INTAKE AND EFFLUENT CHARACTERISTICS (continued from page 3 of Form 2-C)

PART A - You must provide the results of at least one analysis for every pollutant in this table. Complete one table for each outfall. See instructions for additional details.

1. POLLUTANT	2. EFFLUENT		3. UNITS (specify if blank)		4. INTAKE (optional)	
	a. MAXIMUM DAILY VALUE (1) CONCENTRATION	b. MAXIMUM DAILY VALUE (2) MASS	c. LONG TERM AVERAGE VALUE (1) CONCENTRATION	d. NO. OF ANALYSES	e. LONG TERM AVERAGE VALUE (1) MASS	f. NO. OF ANALYSES
a. Biochemical Oxygen Demand (BOD)						
b. Chemical Oxygen Demand (COD)						
c. Total Organic Carbon (TOC)						
d. Total Suspended Solids (TSS)						
e. Ammonia (as N)						
f. Flow	VALUE	VALUE			VALUE	
g. Temperature (winter)	VALUE	VALUE			VALUE	
h. Temperature (summer)	VALUE	VALUE			VALUE	
i. pH	MINIMUM	MAXIMUM			STANDARD UNITS	

PART B - Mark "X" in column 2-a for each pollutant you know or have reason to believe is present. Mark "X" in column 2-b for each pollutant you believe to be absent. If you mark column 2-a for any pollutant, you must provide the results of at least one analysis for that pollutant. Complete one table for each outfall. See the instructions for additional details and requirements.

1. POLLUTANT AND CAS NO. (if available)	2. MARK 'X'		3. EFFLUENT		4. UNITS		5. INTAKE (optional)	
	a. PRESENT	b. ABSENT	b. MAXIMUM DAILY VALUE (1) CONCENTRATION	c. LONG TERM AVERAGE VALUE (2) MASS	d. NO. OF ANALYSES	e. CONCENTRATION	f. MASS	g. NO. OF ANALYSES
a. Bromide (24000-87-8)								
b. Chlorine, Total Residual								
c. Color								
d. Fecal Coliform								
e. Fluoride (16984-48-8)								
f. Nitrate-Nitrite (as N)								

EPA Form 3510-2C (5-00)

PAGE V-1

CONTINUE ON REVERSE

ITEM V-B CONTINUED FROM FRONT

1. POLLUTANT AND GAS NO. (if applicable)	2. MARK 'X' a. SEC. b. SEC. c. SEC. d. SEC. e. SEC. f. SEC. g. SEC. h. SEC. i. SEC. j. SEC. k. SEC. l. SEC. m. SEC. n. SEC. o. SEC. p. SEC. q. SEC. r. SEC. s. SEC. t. SEC. u. SEC. v. SEC. w. SEC. x. SEC. y. SEC. z. SEC. aa. SEC. ab. SEC. ac. SEC. ad. SEC. ae. SEC. af. SEC. ag. SEC. ah. SEC. ai. SEC. aj. SEC. ak. SEC. al. SEC. am. SEC. an. SEC. ao. SEC. ap. SEC. aq. SEC. ar. SEC. as. SEC. at. SEC. au. SEC. av. SEC. aw. SEC. ax. SEC. ay. SEC. az. SEC. ba. SEC. bb. SEC. bc. SEC. bd. SEC. be. SEC. bf. SEC. bg. SEC. bh. SEC. bi. SEC. bj. SEC. bk. SEC. bl. SEC. bm. SEC. bn. SEC. bo. SEC. bp. SEC. bq. SEC. br. SEC. bs. SEC. bt. SEC. bu. SEC. bv. SEC. bw. SEC. bx. SEC. by. SEC. bz. SEC. ca. SEC. cb. SEC. cc. SEC. cd. SEC. ce. SEC. cf. SEC. cg. SEC. ch. SEC. ci. SEC. cj. SEC. ck. SEC. cl. SEC. cm. SEC. cn. SEC. co. SEC. cp. SEC. cq. SEC. cr. SEC. cs. SEC. ct. SEC. cu. SEC. cv. SEC. cw. SEC. cx. SEC. cy. SEC. cz. SEC. da. SEC. db. SEC. dc. SEC. dd. SEC. de. SEC. df. SEC. dg. SEC. dh. SEC. di. SEC. dj. SEC. dk. SEC. dl. SEC. dm. SEC. dn. SEC. do. SEC. dp. SEC. dq. SEC. dr. SEC. ds. SEC. dt. SEC. du. SEC. dv. SEC. dw. SEC. dx. SEC. dy. SEC. dz. SEC. ea. SEC. eb. SEC. ec. SEC. ed. SEC. ee. SEC. ef. SEC. eg. SEC. eh. SEC. ei. SEC. ej. SEC. ek. SEC. el. SEC. em. SEC. en. SEC. eo. SEC. ep. SEC. eq. SEC. er. SEC. es. SEC. et. SEC. eu. SEC. ev. SEC. ew. SEC. ex. SEC. ey. SEC. ez. SEC. fa. SEC. fb. SEC. fc. SEC. fd. SEC. fe. SEC. ff. SEC. fg. SEC. fh. SEC. fi. SEC. fj. SEC. fk. SEC. fl. SEC. fm. SEC. fn. SEC. fo. SEC. fp. SEC. fq. SEC. fr. SEC. fs. SEC. ft. SEC. fu. SEC. fv. SEC. fw. SEC. fx. SEC. fy. SEC. fz. SEC. ga. SEC. gb. SEC. gc. SEC. gd. SEC. ge. SEC. gf. SEC. gg. SEC. gh. SEC. gi. SEC. gj. SEC. gk. SEC. gl. SEC. gm. SEC. gn. SEC. go. SEC. gp. SEC. gq. SEC. gr. SEC. gs. SEC. gt. SEC. gu. SEC. gv. SEC. gw. SEC. gx. SEC. gy. SEC. gz. SEC. ha. SEC. hb. SEC. hc. SEC. hd. SEC. he. SEC. hf. SEC. hg. SEC. hh. SEC. hi. SEC. hj. SEC. hk. SEC. hl. SEC. hm. SEC. hn. SEC. ho. SEC. hp. SEC. hq. SEC. hr. SEC. hs. SEC. ht. SEC. hu. SEC. hv. SEC. hw. SEC. hx. SEC. hy. SEC. hz. SEC. ia. SEC. ib. SEC. ic. SEC. id. SEC. ie. SEC. if. SEC. ig. SEC. ih. SEC. ii. SEC. ij. SEC. ik. SEC. il. SEC. im. SEC. in. SEC. io. SEC. ip. SEC. iq. SEC. ir. SEC. is. SEC. it. SEC. iu. SEC. iv. SEC. iw. SEC. ix. SEC. iy. SEC. iz. SEC. ja. SEC. jb. SEC. jc. SEC. jd. SEC. je. SEC. jf. SEC. jg. SEC. jh. SEC. ji. SEC. jj. SEC. jk. SEC. jl. SEC. jm. SEC. jn. SEC. jo. SEC. jp. SEC. jq. SEC. jr. SEC. js. SEC. jt. SEC. ju. SEC. jv. SEC. jw. SEC. jx. SEC. jy. SEC. jz. SEC. ka. SEC. kb. SEC. kc. SEC. kd. SEC. ke. SEC. kf. SEC. kg. SEC. kh. SEC. ki. SEC. kj. SEC. kk. SEC. kl. SEC. km. SEC. kn. SEC. ko. SEC. kp. SEC. kq. SEC. kr. SEC. ks. SEC. kt. SEC. ku. SEC. kv. SEC. kw. SEC. kx. SEC. ky. SEC. kz. SEC. la. SEC. lb. SEC. lc. SEC. ld. SEC. le. SEC. lf. SEC. lg. SEC. lh. SEC. li. SEC. lj. SEC. lk. SEC. ll. SEC. lm. SEC. ln. SEC. lo. SEC. lp. SEC. lq. SEC. lr. SEC. ls. SEC. lt. SEC. lu. SEC. lv. SEC. lw. SEC. lx. SEC. ly. SEC. lz. SEC. ma. SEC. mb. SEC. mc. SEC. md. SEC. me. SEC. mf. SEC. mg. SEC. mh. SEC. mi. SEC. mj. SEC. mk. SEC. ml. SEC. mn. SEC. mo. SEC. mp. SEC. mq. SEC. mr. SEC. ms. SEC. mt. SEC. mu. SEC. mv. SEC. mw. SEC. mx. SEC. my. SEC. mz. SEC. na. SEC. nb. SEC. nc. SEC. nd. SEC. ne. SEC. nf. SEC. ng. SEC. nh. SEC. ni. SEC. nj. SEC. nk. SEC. nl. SEC. nm. SEC. no. SEC. np. SEC. nq. SEC. nr. SEC. ns. SEC. nt. SEC. nu. SEC. nv. SEC. nw. SEC. nx. SEC. ny. SEC. nz. SEC. oa. SEC. ob. SEC. oc. SEC. od. SEC. oe. SEC. of. SEC. og. SEC. oh. SEC. oi. SEC. oj. SEC. ok. SEC. ol. SEC. om. SEC. on. SEC. oo. SEC. op. SEC. oq. SEC. or. SEC. os. SEC. ot. SEC. ou. SEC. ov. SEC. ow. SEC. ox. SEC. oy. SEC. oz. SEC. pa. SEC. pb. SEC. pc. SEC. pd. SEC. pe. SEC. pf. SEC. pg. SEC. ph. SEC. pi. SEC. pj. SEC. pk. SEC. pl. SEC. pm. SEC. pn. SEC. po. SEC. pp. SEC. pq. SEC. pr. SEC. ps. SEC. pt. SEC. pu. SEC. pv. SEC. pw. SEC. px. SEC. py. SEC. pz. SEC. qa. SEC. qb. SEC. qc. SEC. qd. SEC. qe. SEC. qf. SEC. qg. SEC. qh. SEC. qi. SEC. qj. SEC. qk. SEC. ql. SEC. qm. SEC. qn. SEC. qo. SEC. qp. SEC. qq. SEC. qr. SEC. qs. SEC. qt. SEC. qu. SEC. qv. SEC. qw. SEC. qx. SEC. qy. SEC. qz. SEC. ra. SEC. rb. SEC. rc. SEC. rd. SEC. re. SEC. rf. SEC. rg. SEC. rh. SEC. ri. SEC. rj. SEC. rk. SEC. rl. SEC. rm. SEC. rn. SEC. ro. SEC. rp. SEC. rq. SEC. rr. SEC. rs. SEC. rt. SEC. ru. SEC. rv. SEC. rw. SEC. rx. SEC. ry. SEC. rz. SEC. sa. SEC. sb. SEC. sc. SEC. sd. SEC. se. SEC. sf. SEC. sg. SEC. sh. SEC. si. SEC. sj. SEC. sk. SEC. sl. SEC. sm. SEC. sn. SEC. so. SEC. sp. SEC. sq. SEC. sr. SEC. ss. SEC. st. SEC. su. SEC. sv. SEC. sw. SEC. sx. SEC. sy. SEC. sz. SEC. ta. SEC. tb. SEC. tc. SEC. td. SEC. te. SEC. tf. SEC. tg. SEC. th. SEC. ti. SEC. tj. SEC. tk. SEC. tl. SEC. tm. SEC. tn. SEC. to. SEC. tp. SEC. tq. SEC. tr. SEC. ts. SEC. tu. SEC. tv. SEC. tw. SEC. tx. SEC. ty. SEC. tz. SEC. ua. SEC. ub. SEC. uc. SEC. ud. SEC. ue. SEC. uf. SEC. ug. SEC. uh. SEC. ui. SEC. uj. SEC. uk. SEC. ul. SEC. um. SEC. un. SEC. uo. SEC. up. SEC. uq. SEC. ur. SEC. us. SEC. ut. SEC. uu. SEC. uv. SEC. uw. SEC. ux. SEC. uy. SEC. uz. SEC. va. SEC. vb. SEC. vc. SEC. vd. SEC. ve. SEC. vf. SEC. vg. SEC. vh. SEC. vi. SEC. vj. SEC. vk. SEC. vl. SEC. vm. SEC. vn. SEC. vo. SEC. vp. SEC. vq. SEC. vr. SEC. vs. SEC. vt. SEC. vu. SEC. vv. SEC. vw. SEC. vx. SEC. vy. SEC. vz. SEC. wa. SEC. wb. SEC. wc. SEC. wd. SEC. we. SEC. wf. SEC. wg. SEC. wh. SEC. wi. SEC. wj. SEC. wk. SEC. wl. SEC. wm. SEC. wn. SEC. wo. SEC. wp. SEC. wq. SEC. wr. SEC. ws. SEC. wt. SEC. wx. SEC. wy. SEC. wz. SEC. xa. SEC. xb. SEC. xc. SEC. xd. SEC. xe. SEC. xf. SEC. xg. SEC. xh. SEC. xi. SEC. xj. SEC. xk. SEC. xl. SEC. xm. SEC. xn. SEC. xo. SEC. xp. SEC. xq. SEC. xr. SEC. xs. SEC. xt. SEC. xu. SEC. xv. SEC. xw. SEC. xx. SEC. xy. SEC. xz. SEC. ya. SEC. yb. SEC. yc. SEC. yd. SEC. ye. SEC. yf. SEC. yg. SEC. yh. SEC. yi. SEC. yj. SEC. yk. SEC. yl. SEC. ym. SEC. yn. SEC. yo. SEC. yp. SEC. yq. SEC. yr. SEC. ys. SEC. yt. SEC. yu. SEC. yv. SEC. yw. SEC. yx. SEC. yy. SEC. yz. SEC. za. SEC. zb. SEC. zc. SEC. zd. SEC. ze. SEC. zf. SEC. zg. SEC. zh. SEC. zi. SEC. zj. SEC. zk. SEC. zl. SEC. zm. SEC. zn. SEC. zo. SEC. zp. SEC. zq. SEC. zr. SEC. zs. SEC. zt. SEC. zu. SEC. zv. SEC. zw. SEC. zx. SEC. zy. SEC. zz.	3. EFFLUENT		4. UNITS		5. INTAKE (optional)	
		a. MAXIMUM DAILY VALUE (1) CONCENTRATION (2) MASS	b. MAXIMUM 30 DAY VALUE (if applicable) (1) CONCENTRATION (2) MASS	a. CONCENTRATION (1) CONCENTRATION (2) MASS	b. MASS (1) CONCENTRATION (2) MASS	a. AVERAGE VALUE (1) CONCENTRATION (2) MASS	b. NO. OF ANAL. YSES
i. Nitrogen, Total Organic (as N)							
h. Oil and Grease							
i. Phosphorus (as P), Total (7723-14-0)							
J. Radioactivity							
(1) Alpha, Total							
(2) Beta, Total							
(3) Radium, Total							
(4) Radium 226, Total							
k. Sulfate (as SO ₄) (14806-79-8)							
l. Sulfide (as S)							
m. Sulfite (as SO ₃) (14285-45-3)							
n. Surfactants							
o. Aluminum, Total (7429-90-6)							
p. Barium, Total (7440-39-3)							
q. Boron, Total (7440-42-8)							
r. Cobalt, Total (7440-48-4)							
s. Iron, Total (7439-89-6)							
t. Magnesium, Total (7439-95-4)							
u. Molybdenum, Total (7439-98-7)							
v. Manganese, Total (7439-96-6)							
w. Tin, Total (7440-31-6)							
x. Titanium, Total (7440-32-6)							

EPA THIS IS A DRAFT COPY

EPA Form 3510-2C (5-80)

PAGE V-2

CONTINUE ON PAGE V-3

Form Approved OMB No. 158-R0173

EPA I.D. NUMBER (copy from Item 1 of Form 1) OUTFALL NUMBER

CONTINUED FROM PAGE 3 OF FORM 2-C

PART C - If you are a primary industry and this outfall contains process wastewater, refer to Table 2c-2 in the instructions to determine which of the GC/MS fractions you must test for. Mark "X" in column 2-a for all such GC/MS fractions that apply to your industry and for ALL toxic metals, cyanides, and total phenols. If you are not required to mark column 2-a (secondary industries, non-process wastewater outfalls, and non-required GC/MS fractions), mark "X" in column 2-b for each pollutant you know or have reason to believe is present. Mark "X" in column 2-c for each pollutant you believe to be absent. If you mark either columns 2-a or 2-b for any pollutant, you must provide the results of at least one analysis for that pollutant. Note that there are seven pages to this part; please review each carefully. Complete one table (all seven pages) for each outfall. See instructions for additional details and requirements.

1. POLLUTANT NUMBER (if available)	2. MARK 'X'		3. EFFLUENT			4. UNITS			5. INTAKE (optional)			
	AVG. NO. OF EQUIP. SERV. DAILY	C. REC. EQUIP. SERV. DAILY	A. MAXIMUM DAILY VALUE (1) CONCENTRATION	B. MAXIMUM 30 DAY VALUE (2) CONCENTRATION	C. LONG TERM AVG. VALUE (if available) (3) MASS	D. NO. OF ANAL. YEARS	B. CONCEN- TRATION	B. MASS	A. LONG TERM AVG. BASE VALUE (1) CONCEN- TRATION	(3) MASS	D. NO. OF ANAL. YEARS	
1M. Antimony Total (7440-36-0)												
2M. Arsenic, Total (7440-38-2)												
3M. Beryllium, Total (7440-41-7)												
4M. Cadmium, Total (7440-43-9)												
5M. Chromium, Total (7440-47-3)												
6M. Copper, Total (7850-80-8)												
7M. Lead, Total (7439-97-8)												
8M. Mercury, Total (7439-97-6)												
9M. Nickel, Total (7440-02-0)												
10M. Selenium, Total (7782-49-2)												
11M. Silver, Total (7440-22-4)												
12M. Thallium, Total (7440-28-0)												
13M. Zinc, Total (7440-66-5)												
14M. Cyanide, Total (57-12-5)												
15M. Phenols, Total												
DIOXIN												
2,3,7,8-Tetra-chlorodibenzo P-Dioxin (1784-01-6)												

EPA COMPLIANCE

DESCRIBE RESULTS

EPA Form 3510-2C (5-80)

PAGE V-3

CONTINUE ON REVERSE

1. POLLUTANT AND CAS NUMBER (if available)	2. MARK 'X' IN THE APPROPRIATE SQUARE		3. EFFLUENT		4. UNITS		5. INTAKE (optional)	
	a. MARK 'X' IN THE APPROPRIATE SQUARE	b. MARK 'X' IN THE APPROPRIATE SQUARE	b. MAXIMUM DAILY VALUE (1) CONCENTRATION (2) MASS	d. MAXIMUM 30 DAY VALUE (1) CONCENTRATION (2) MASS	a. LONG TERM AVERAGE VALUE (1) CONCENTRATION (2) MASS	b. NO. OF ANALYSES	a. LONG TERM AVERAGE VALUE (1) CONCENTRATION (2) MASS	b. NO. OF ANALYSES
GC/MS FRACTION - VOLATILE COMPOUNDS								
1V. Acrolein (107-02-8)								
2V. Acrylonitrile (107-13-1)								
3V. Benzene (71-43-2)								
4V. Bis (Chloromethyl) Ether (542-88-1)								
5V. Bromoform (75-26-2)								
6V. Carbon Tetrachloride (56-23-5)								
7V. Chlorobenzene (108-90-7)								
8V. Chlorodibromomethane (124-48-1)								
9V. Chloroethane (75-00-3)								
10V. 2-Chloroethylvinyl Ether (110-75-8)								
11V. Chloroform (67-66-3)								
12V. Dichlorobromomethane (75-27-4)								
13V. Dichlorodifluoromethane (75-71-8)								
14V. 1,1-Dichloroethane (75-34-3)								
15V. 1,2-Dichloroethane (107-06-2)								
16V. 1,1-Dichloroethylene (75-35-4)								
17V. 1,2-Dichloropropane (78-27-6)								
18V. 1,2-Dichloropropylene (542-75-6)								
19V. Ethylbenzene (100-41-4)								
20V. Methyl Bromide (74-83-9)								
21V. Methyl Chloride (74-87-3)								

EPA/MS/EFCS

CONTINUED FROM THE FRONT

EPA Form 3510-2C (5-80)

PAGE V-4

CONTINUE ON PAGE V-5

Form Approved OMB No. 158-R0173

CONTINUED FROM PAGE V-4

1. POLLUTANT AND GAS NUMBER (if available)	2. MARK 'X'		3. EFFLUENT				4. UNITS				5. INTAKE (optional)	
	A. TEST EQUIP. SENT	B. SEC. EQUIP. SENT	B. MAXIMUM DAILY VALUE (1) CONCENTRATION	(2) MASS	G. LONG TERM (30-DAY) VALUE (1) CONCENTRATION	(2) MASS	B. CONCENTRATION	B. MASS	(1) AVERAGE VALUE	(2) MASS	D. NO. OF ANAL. YSES	D. NO. OF ANAL. YSES
GC/MS FRACTION - VOLATILE COMPOUNDS (continued)												
22V. Methylene Chloride (75-09-2)												
23V. 1,1,2,2-Tetrachloroethane (78-34-5)												
24V. Tetrachloroethylene (127-18-4)												
25V. Toluene (108-88-2)												
26V. 1,2-Trichloroethylene (156-60-6)												
27V. 1,1,1-Trichloroethane (71-55-6)												
28V. 1,1,2-Trichloroethane (79-00-5)												
29V. Trichloroethylene (79-01-6)												
30V. Trichlorofluoromethane (75-69-4)												
31V. Vinyl Chloride (75-01-4)												
GC/MS FRACTION - ACID COMPOUNDS												
1A. 2-Chloropheno (85-87-8)												
2A. 2,4-Dichloropheno (120-83-2)												
3A. 2,4-Dimethylpheno (106-87-9)												
4A. 4-6-Dinitro-Cresol (834-82-1)												
5A. 2,4-Dinitrophenol (81-20-5)												
6A. 2-Nitrophenol (85-75-8)												
7A. 4-Nitrophenol (100-02-7)												
8A. P-Chloro-M-Cresol (89-80-7)												
9A. Pentschloropheno (07-80-8)												
10A. Phenol (108-85-2)												
11A. 2,4,6-Trichloropheno (101-08-2)												

EPA/MS/EEA/C

CONTINUE ON REVERSE

PAGE V-5

EPA Form 3510-2C (5-80)

1. POLLUTANT AND CAS NUMBER (if available)	2. MARK 'X' a. YES b. NO c. CONC. SENT d. SENT e. SENT	3. EFFLUENT				4. UNITS		5. INTAKE (optional)	
		a. MAXIMUM DAILY VALUE (1) CONCENTRATION (2) MASS	b. MAXIMUM DAILY VALUE (1) CONCENTRATION (2) MASS	c. LONG TERM AVERAGE VALUE (1) CONCENTRATION (2) MASS	d. NO. OF ANALYSES	a. CONCENTRATION	b. MASS	a. LONG TERM AVERAGE VALUE (1) CONCENTRATION (2) MASS	b. NO. OF ANALYSES
GC/MS FRACTION - BASE/NEUTRAL COMPOUNDS									
1B. Acenaphthene (83-32-9)									
2B. Acenaphthylene (208-98-6)									
3B. Anthracene (120-12-7)									
4B. Benzidine (92-87-5)									
5B. Benzo (a) Anthracene (56-55-3)									
6B. Benzo (a) Pyrene (50-32-9)									
7B. 3,4-Benzofluoranthene (205-99-2)									
8B. Benzo (ghi) Perylene (191-24-2)									
9B. Benzo (k) Fluoranthene (207-08-9)									
10B. Bis (2-Chlorophenyl) Methane (111-91-1)									
11B. Bis (2-Chlorophenyl) Ether (111-44-4)									
12B. Bis (2-Chloropropyl) Ether (39539-32-9)									
13B. Bis (2-Ethylhexyl) Phthalate (117-81-7)									
14B. 4-Bromophenyl Ether (101-55-3)									
15B. Butyl Benzyl Phthalate (85-68-7)									
16B. 2-Chloronaphthalene (91-58-7)									
17B. 4-Chlorophenyl Ether (1005-72-3)									
18B. Chrysene (218-01-9)									
19B. Dibenzo (a,h) Anthracene (53-70-3)									
20B. 1,2-Dichlorobenzene (95-60-1)									
21B. 1,3-Dichlorobenzene (541-73-1)									

EPA
STANDARD
DATA

CONTINUED FROM THE FRONT

EPA Form 3510-2C (5-80)

PAGE V-6

CONTINUE ON PAGE V-7

1. POLLUTANT AND CAS NUMBER (if available)	2. MARK 'X' AND CAS NUMBER (if available)		3. EFFLUENT		4. UNITS		5. INTAKE (optional)	
	MARK 'X'	CAS NUMBER	MAXIMUM DAILY VALUE (1) CONCENTRATION (2) MASS	MAXIMUM 30 DAY VALUE (1) CONCENTRATION (2) MASS	LONG TERM AVERAGE VALUE (1) CONCENTRATION (2) MASS	CONCENTRATION	MASS	LONG TERM AVERAGE VALUE (1) CONCENTRATION (2) MASS
GC/MS FRACTION - BASE/NEUTRAL COMPOUNDS (continued)								
43B. N-Nitro- codiphenylamine (86-3D-6)								
44B. Phenanthrene (85-01-8)								
45B. Pyrene (129-00-0)								
46B. 1,2,4-Tri- chlorobenzene (120-82-1)								
GC/MS FRACTION - PESTICIDES								
1P. Aldrin (309-00-2)								
2P. α -BHC (319-84-6)								
3P. β -BHC (319-85-7)								
4P. γ -BHC (58-89-9)								
5P. δ -BHC (319-86-8)								
6P. Chlordane (67-74-9)								
7P. 4,4'-DDT (50-29-3)								
8P. 4,4'-DDE (72-55-9)								
9P. 4,4'-DDD (72-54-8)								
10P. Dieldrin (60-57-1)								
11P. α -Endosulfan (115-29-7)								
12P. β -Endosulfan (115-29-7)								
13P. Endosulfan Sulfate (1031-07-8)								
14P. Endrin (72-20-8)								
15P. Endrin Aldehyde (7421-93-4)								
16P. Heptachlor (76-44-8)								

EPA/600/3-80-010

CONTINUE ON PAGE V-9

PAGE V-8

EPA Form 3510-2C (5-80)

Form Approved OMB No. 158-R0173

EPA I.D. NUMBER (copy from Item 1 of Form 1) OUTFALL NUMBER

CONTINUED FROM PAGE V-8

1. POLLUTANT AND CAS NUMBER (if available)	2. MARK 'X' IN BOXES: (1) YES (2) NO	3. EFFLUENT		4. UNITS		5. INTAKE (optional)	
		a. MAXIMUM DAILY VALUE (1) CONCENTRATION (2) MASS	b. MAXIMUM 30 DAY VALUE (1) CONCENTRATION (2) MASS	a. CONCEN-TRATION	b. MASS	a. LONG TERM AVERAGE VALUE (1) CONCEN-TRATION (2) MASS	b. NO. OF ANAL- YSES
GC/MS FRACTION - PESTICIDES (continued)							
17P. Heptachlor Epoxide (102457-3)							
18P. PCB-1242 (53409-21-0)							
19P. PCB-1254 (11007-60-1)							
20P. PCB-1221 (11104-28-2)							
21P. PCB-1232 (11141-16-5)							
22P. PCB-1248 (12672-30-6)							
23P. PCB-1280 (11008-02-6)							
24P. PCB-1016 (12674-11-2)							
25P. Toxaphene (8001-36-2)							

FACSIMILE

EPA Form 3610-2C (5-80)

BILLING CODE 6860-01-C

**Instructions.—Form 3—RCRA
Hazardous Waste Permit Application**

This form must be completed by all applicants who check "yes" to Item II-E in Form 1.

General Instructions

Permit Application Process.—There are two parts to a RCRA permit application—Part A and Part B. Part A consists of this form and Form 1 of the Consolidated Permit Application. Part B requires detailed site-specific information such as geology, hydrology, and engineering data. 40 CFR 122.25 specifies the information that will be required from hazardous waste management facilities in Part B.

RCRA established a procedure for obtaining "interim status" which allows existing hazardous waste management facilities to continue their operations until a final hazardous waste permit is issued. In order to qualify for interim status, existing hazardous waste management facilities must submit Part A of the permit application to EPA within six months after the promulgation of regulations under section 3001 of RCRA (40 CFR Part 261). In order to receive a hazardous waste permit, existing facilities must submit a complete Part B within six months after it is requested by EPA. New facilities must submit both Part A and Part B to EPA at least 180 days before physical construction is expected to commence.

Operation During Interim Status.—As provided in 40 CFR 122.23(b), Part A of the permit application defines the processes to be used for treatment, storage, and disposal of hazardous wastes; the design capacity of such processes; and the specific hazardous wastes to be handled at a facility during the interim status period. Once Part A is submitted to EPA, changes in the hazardous wastes handled, changes in design capacities, changes in processes, and changes in ownership or operational control at a facility during the interim status period may only be made in accordance with the procedures in 40 CFR 123.23(c). Changes in design capacity and changes in processes require prior EPA approval. Changes in the quantity of waste handled at a facility during interim status can be made without submitting a revised Part A provided the quantity does not exceed the design capacities of the processes specified in Part A of the permit application. Failure to furnish all information required to process a permit application is grounds for termination of interim status.

Confidential Information.—All information submitted in this form will

be subject to public disclosure, to the extent provided by RCRA and the Freedom of Information Act, 5 U.S.C. Section 552, and EPA's Business Confidentiality Regulations, 40 CFR Part 2 (see especially 40 CFR 2.305). Persons filing this form may make claims of confidentiality. Such claims must be clearly indicated by marking "confidential" on the specific information on the form for which confidential treatment is requested or on any attachments, and must be accompanied, *at the time of filing*, by a written substantiation of the claim, by answering the following questions:

1. Which portions of the information do you claim are entitled to confidential treatment?

2. For how long is confidential treatment desired for this information?

3. What measures have you taken to guard against undesired disclosure of the information to others?

4. To what extent has the information been disclosed to others, and what precautions have been taken in connection with that disclosure?

5. Has EPA or any other Federal agency made a pertinent confidentiality determination? If so, include a copy of such determination or reference to it, if available.

6. Will disclosure of the information be likely to result in substantial harmful effects on your competitive position? If so, what would those harmful effects be and why should they be viewed as substantial? Explain the causal relationship between disclosure and the harmful effects.

Information covered by a confidentiality claim and the above substantiation will be disclosed by EPA only to the extent and by means of the procedures set forth in 40 CFR Part 2.

If no claim of confidentiality or no substantiation accompanies the information when it is submitted, EPA may make the information available to the public without further notice to the submitter.

Definitions.—Terms used in these instructions and in this form are defined in the Glossary section of these instructions. For additional definitions and procedures to use in applying for a permit for a hazardous waste management facility, refer to the regulations promulgated under Section 3005 of RCRA and published in 40 CFR Parts 122 and 124.

Line by Line Instructions

Completing this form. Please type or print in the unshaded areas only. Some items have small graduation marks or boxes in the fill in spaces. These marks

indicate the number of characters that may be inputted into our data system. The marks are spaced at 1/6" intervals which accommodate elite type (12 characters per inch—one space between letters). If you do not have a typewriter with elite type then please print, placing each character between the marks. Abbreviate if necessary to stay within the number of characters allowed for each item. Use one space for breaks between words, but not for punctuation marks unless the space is needed to clarify your information.

Item I. Existing hazardous waste management facilities should enter their EPA Identification Number (if known). New facilities should leave this item blank.

Item II. A. First Application.—If this is the first application that is being filed for the facility place an "X" in either the Existing Facility box or the New Facility box.

1. Existing Facility.—Existing facilities are:

(1) Those facilities which received hazardous waste for treatment, storage, and/or disposal on or before October 21, 1976, or

(2) Those facilities for which construction had commenced on or before October 21, 1976. Construction had "commenced" only if:

(a) The owner or operator had obtained all necessary Federal, State, and local pre-construction approvals or permits; and

(b1) A continuous physical, on-site construction program had begun (facility design or other preliminary non-physical and non-site specific preparatory activities do not constitute an on-site construction program), or

(b2) The owner or operator had entered into contractual obligations (options to purchase or contracts for feasibility, engineering, and design studies do not constitute contractual obligations) which could not be cancelled or modified without substantial loss. Generally, a loss is deemed substantial if the amount an owner or operator must pay to cancel construction agreements or stop construction exceeds 10% of the total project cost.

(Note—This definition of "existing facility" reflects the literal language of the statute. However, EPA believes that amendments to RCRA now in conference will shortly be enacted and will change the date for determining when a facility is an "existing facility" to one no earlier than May of 1980; indications are the conferees are considering October 30, 1980. When those amendments are enacted, EPA

will amend the definition of "existing facility."

Accordingly, EPA encourages every facility built or under construction on the promulgation date of the RCRA program regulations to notify EPA and file Part A of the permit application so that it can be quickly processed for interim status when the change in the law takes effect.)

Existing Facility Date.—If the Existing Facility box is marked, enter the date hazardous waste operations began (i.e., the date the facility began treating, storing, or disposing of hazardous waste) or the date construction commenced.

2. New Facility.—New facilities are all facilities for which construction commenced, or will commence, after October 21, 1976.

New Facility Date.—If the New Facility box is marked, enter the date that operation began or is expected to begin.

B. Revised Application.—If this is a subsequent application that is being filed to amend data filed in a previous application, place an "X" in the appropriate box to indicate whether the facility has interim status or a permit.

1. Facility Has Interim Status.—Place an "X" in this box if this is a revised application to make changes at a facility during the interim status period.

2. Facility Has a Permit.—Place an "X" in this box if this is a revised application to make changes at a facility for which a permit has been issued.

(Note—When submitting a revised application, applicants must resubmit in their entirety each item on the application for which changes are requested. In addition, items I and IX (and item X if applicable) must be completed. It is not necessary to resubmit information for other items that will not change).

Item III. The information in item III describes all the processes that will be used to treat, store, or dispose of hazardous waste at existing facilities during the interim status period, and at new facilities after a permit is issued. The design capacity of each process must be provided as part of the description. The design capacity of injection wells and landfills at existing facilities should be measured as the remaining, unused capacity. See the form for the detailed instructions to item III.

Item IV. The information in item IV describes all the hazardous wastes that will be treated, stored, or disposed at existing facilities during the interim status period, and at new facilities after a permit is issued. In addition, the processes that will be used to treat,

store, or dispose of each waste and the estimated annual quantity of each waste must be provided. See the form for the detailed instructions to item IV.

Item V. All existing facilities must include a drawing showing the general layout of the facility during interim status. This drawing should be approximately to scale and fit in the space provided on the form. This drawing should show the following:

- The property boundaries of the facility;
- The areas occupied by all storage, treatment, or disposal operations that will be used during interim status;
- The name of each operation.
(Example—multiple hearth incinerator, drum storage area, etc.):
- Areas of past storage, treatment, or disposal operations;
- Areas of future storage, treatment, or disposal operations; and
- The approximate dimensions of the property boundaries and all areas

See Figure 3-1 for an example of a facility drawing. New facilities do not have to complete this item.

BILLING CODE 6560-01-M

Continued from page 4.

Form Approved OMB No. 158-S8004

V. FACILITY DRAWING (see page 4)

EXAMPLE

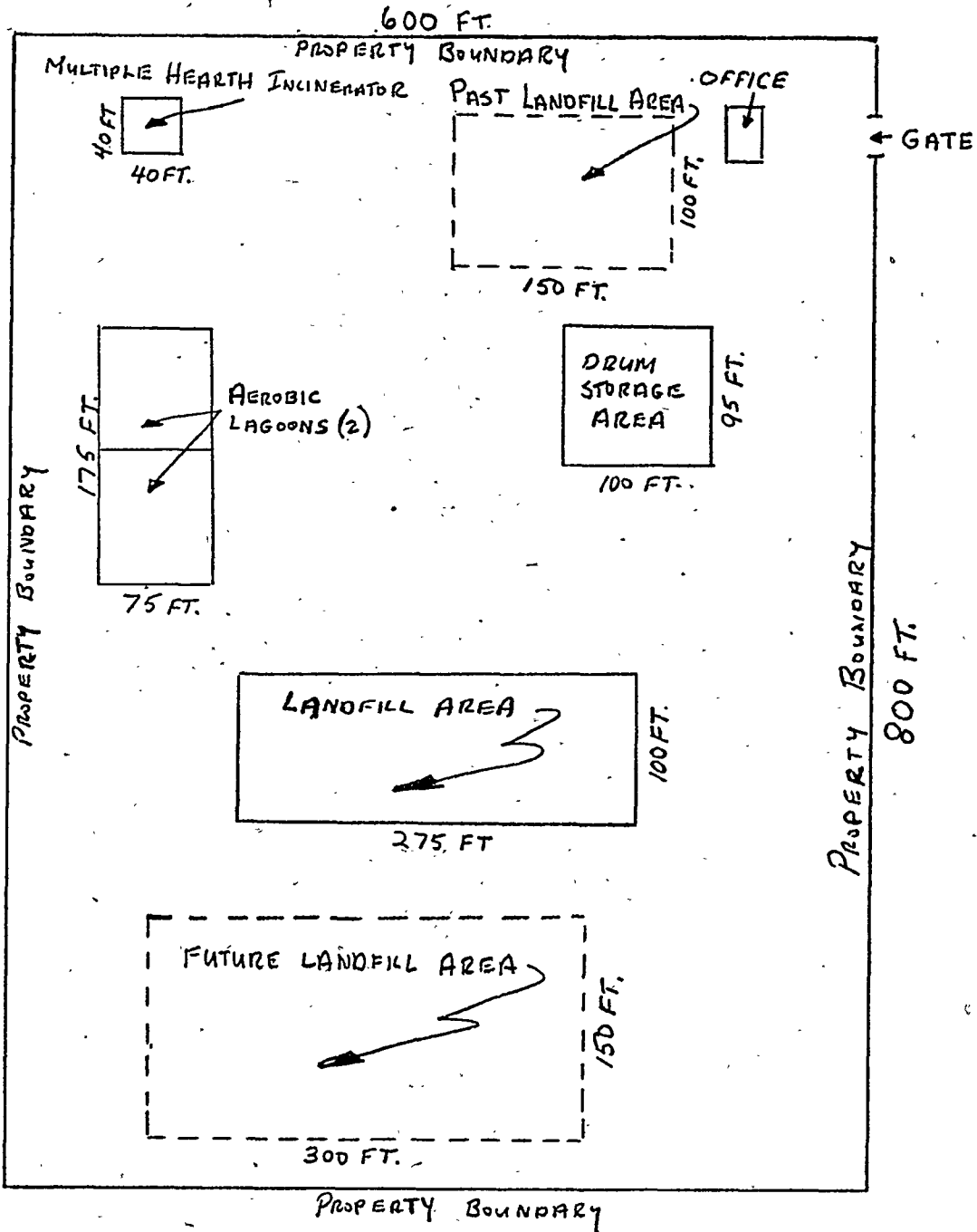

SCALE: 1 INCH = 1 FOOT

FIGURE 3-1

Item VI. All existing facilities must include photographs that clearly delineate *all* existing structures; *all* existing areas for storing, treating, or disposing of hazardous waste; and *all* known sites of future storage, treatment, or disposal operations. Photographs may be color or black and white, ground-level or aerial. Indicate the date the photograph was taken on the back of each photograph.

Item VII. Enter the latitude and longitude of the facility in degrees, minutes, and seconds. For larger facilities, enter the latitude and longitude at the approximate mid-point of the facility. You may use the map you provided for Item XI of Form 1 to determine latitude and longitude. Latitude and longitude information is also available from Regional Offices of the U.S. Department of Interior, Geological Survey; from State Agencies, such as the Department of Natural Resources; and from the National Cartographic Information Center, U.S. Geological Survey, 12202 Sunrise Valley Dr., Reston, VA. 22092.

Item VIII. See the form for the instructions to item VIII.

Item IX and Item X. All facility owners must sign Item IX. If the facility will be operated by someone other than the owner, then the operator must sign Item X. Federal regulations require the certification to be signed as follows.

(1) For a corporation, by a principal executive officer at least the level of vice president;

(2) For a partnership or sole proprietorship, by a general partner or the proprietor, respectively; or

(3) For a municipality, State, Federal, or other public facility, by either a principal executive officer or ranking elected official.

The Resource Conservation and Recovery Act provides for severe penalties for submitting false information on this application form.

Section 3008(d) of the Resource Conservation and Recovery Act provides that "Any person who knowingly makes any false statement or representation in any application, . . . shall, upon conviction be subject to a fine of not more than \$25,000 for each day of violation, or to imprisonment not to exceed one year, or both."

BILLING CODE 6550-01-M

Please print or type in the unshaded areas only
 (fill-in areas are spaced for elite type, i.e., 12 characters/inch).

Form Approved OMB No. 158-S80004

FORM 3	U.S. ENVIRONMENTAL PROTECTION AGENCY HAZARDOUS WASTE PERMIT APPLICATION <i>Consolidated Permits Program</i> <small>(This information is required under Section 3005 of RCRA.)</small>	I. EPA I.D. NUMBER <table border="1" style="width:100%; border-collapse: collapse;"> <tr> <td style="width:10%;">1</td><td style="width:10%;">2</td><td style="width:10%;">3</td><td style="width:10%;">4</td><td style="width:10%;">5</td><td style="width:10%;">6</td><td style="width:10%;">7</td><td style="width:10%;">8</td><td style="width:10%;">9</td><td style="width:10%;">10</td><td style="width:10%;">11</td><td style="width:10%;">12</td> </tr> <tr> <td></td><td></td><td></td><td></td><td></td><td></td><td></td><td></td><td></td><td></td><td></td><td></td> </tr> </table>	1	2	3	4	5	6	7	8	9	10	11	12												
1	2	3	4	5	6	7	8	9	10	11	12															

FOR OFFICIAL USE ONLY																							
APPLICATION APPROVED <table border="1" style="width:100%; border-collapse: collapse;"> <tr> <td style="width:10%;">32</td><td style="width:10%;">33</td><td style="width:10%;">34</td><td style="width:10%;">35</td><td style="width:10%;">36</td><td style="width:10%;">37</td><td style="width:10%;">38</td><td style="width:10%;">39</td><td style="width:10%;">40</td><td style="width:10%;">41</td><td style="width:10%;">42</td> </tr> <tr> <td></td><td></td><td></td><td></td><td></td><td></td><td></td><td></td><td></td><td></td><td></td> </tr> </table>	32	33	34	35	36	37	38	39	40	41	42												DATE RECEIVED (yr., mo., & day)
32	33	34	35	36	37	38	39	40	41	42													
COMMENTS																							

II. FIRST OR REVISED APPLICATION

Place an "X" in the appropriate box in A or B below (mark one box only) to indicate whether this is the first application you are submitting for your facility or a revised application. If this is your first application and you already know your facility's EPA I.D. Number, or if this is a revised application, enter your facility's EPA I.D. Number in Item I above.

A. FIRST APPLICATION (place an "X" below and provide the appropriate date)

1. EXISTING FACILITY (See instructions for definition of "existing" facility. Complete item below.)

2. NEW FACILITY (Complete item below.)

C

YR.	MO.	DAY	YR.	MO.	DAY
73	74	75	73	74	75

FOR EXISTING FACILITIES, PROVIDE THE DATE (yr., mo., & day) OPERATION BEGAN OR THE DATE CONSTRUCTION COMMENCED (use the boxes to the left)

B. REVISED APPLICATION (place an "X" below and complete Item I above)

1. FACILITY HAS INTERIM STATUS

2. FACILITY HAS A RCRA PERMIT

III. PROCESSES - CODES AND DESIGN CAPACITIES

A. PROCESS CODE - Enter the code from the list of process codes below that best describes each process to be used at the facility. Ten lines are provided for entering codes. If more lines are needed, enter the code(s) in the space provided. If a process will be used that is not included in the list of codes below, then describe the process (including its design capacity) in the space provided on the form (Item III-C).

B. PROCESS DESIGN CAPACITY - For each code entered in column A enter the capacity of the process.

1. AMOUNT - Enter the amount.

2. UNIT OF MEASURE - For each amount entered in column B(1), enter the code from the list of unit measure codes below that describes the unit of measure used. Only the units of measure that are listed below should be used.

PROCESS	PRO-CESS CODE	APPROPRIATE UNITS OF MEASURE FOR PROCESS DESIGN CAPACITY	PROCESS	PRO-CESS CODE	APPROPRIATE UNITS OF MEASURE FOR PROCESS DESIGN CAPACITY
Storage:			Treatment:		
CONTAINER (barrel, drum, etc.)	S01	GALLONS OR LITERS	TANK	T01	GALLONS PER DAY OR LITERS PER DAY
TANK	S02	GALLONS OR LITERS	SURFACE IMPOUNDMENT	T02	GALLONS PER DAY OR LITERS PER DAY
WASTE PILE	S03	CUBIC YARDS OR CUBIC METERS	INCINERATOR	T03	TONS PER HOUR, METRIC TONS PER HOUR, GALLONS PER HOUR OR LITERS PER HOUR
SURFACE IMPOUNDMENT	S04	GALLONS OR LITERS	OTHER (Use for physical, chemical, biological treatment processes not occurring in tanks, surface impoundments or incinerators. Describe the processes in the space provided; Item III-C.)	T04	GALLONS PER DAY OR LITERS PER DAY
Disposal:					
INJECTION WELL	D79	GALLONS OR LITERS			
LANDFILL	D80	ACRE-FEET (the volume that would cover one acre to a depth of one foot) OR HECTARE-METER			
LAND APPLICATION	D81	ACRES OR HECTARES			
OCEAN DISPOSAL	D82	GALLONS PER DAY OR LITERS PER DAY			
SURFACE IMPOUNDMENT	D83	GALLONS OR LITERS			

UNIT OF MEASURE	UNIT OF MEASURE CODE	UNIT OF MEASURE	UNIT OF MEASURE CODE	UNIT OF MEASURE	UNIT OF MEASURE CODE
GALLONS	G	LITERS PER DAY	V	ACRE-FEET	A
LITERS	L	TONS PER HOUR	D	HECTARE-METER	F
CUBIC YARDS	Y	METRIC TONS PER HOUR	W	ACRES	B
CUBIC METERS	C	GALLONS PER HOUR	E	HECTARES	Q
GALLONS PER DAY	U	LITERS PER HOUR	H		

EXAMPLE FOR COMPLETING ITEM III (shown in line numbers X-1 and X-2 below): A facility has two storage tanks, one tank can hold 200 gallons and the other can hold 400 gallons. The facility also has an incinerator that can burn up to 20 gallons per hour.

DUP															
III															
LINE NUMBER	A. PRO-CESS CODE (from list above)	B. PROCESS DESIGN CAPACITY					FOR OFFICIAL USE ONLY	LINE NUMBER	A. PRO-CESS CODE (from list above)	B. PROCESS DESIGN CAPACITY					FOR OFFICIAL USE ONLY
		1. AMOUNT (specify)	2. UNIT OF MEASURE (enter code)							1. AMOUNT	2. UNIT OF MEASURE (enter code)				
X-1	S 0 2	600	G					5							
X-2	T 0 3	20	E					6							
1								7							
2								8							
3								9							
4								10							

Continued from the front.

III. PROCESSES (continued)

C. SPACE FOR ADDITIONAL PROCESS CODES OR FOR DESCRIBING OTHER PROCESSES (code "T04"). FOR EACH PROCESS ENTERED HERE INCLUDE DESIGN CAPACITY.

IV. DESCRIPTION OF HAZARDOUS WASTES

A. EPA HAZARDOUS WASTE NUMBER — Enter the four-digit number from 40 CFR, Subpart D for each listed hazardous waste you will handle. If you handle hazardous wastes which are not listed in 40 CFR, Subpart D, enter the four-digit number(s) from 40 CFR, Subpart C that describes the characteristics and/or the toxic contaminants of those hazardous wastes.

B. ESTIMATED ANNUAL QUANTITY — For each listed waste entered in column A estimate the quantity of that waste that will be handled on an annual basis. For each characteristic or toxic contaminant entered in column A estimate the total annual quantity of all the non-listed waste(s) that will be handled which possess that characteristic or contaminant.

C. UNIT OF MEASURE — For each quantity entered in column B enter the unit of measure code. Units of measure which must be used and the appropriate codes are:

ENGLISH UNIT OF MEASURE		CODE	METRIC UNIT OF MEASURE		CODE
POUNDS	P	KILOGRAMS	K
TONS	T	METRIC TONS	M

If facility records use any other unit of measure for quantity, the units of measure must be converted into one of the required units of measure taking into account the appropriate density or specific gravity of the waste.

D. PROCESSES

1. PROCESS CODES:

For listed hazardous waste: For each listed hazardous waste entered in column A select the code(s) from the list of process codes contained in Item III to indicate how the waste will be stored, treated, and/or disposed of at the facility.

For non-listed hazardous waste: For each characteristic or toxic contaminant entered in column A, select the code(s) from the list of process codes contained in Item III to indicate all the processes that will be used to store, treat, and/or dispose of all the non-listed hazardous wastes that possess that characteristic or toxic contaminant.

Note: Four spaces are provided for entering process codes. If more are needed: (1) Enter the first three as described above; (2) Enter "000" in the extreme right box of Item IV-D(1); and (3) Enter in the space provided on page 4, the line number and the additional code(s).

2. PROCESS DESCRIPTION: If a code is not listed for a process that will be used, describe the process in the space provided on the form.

NOTE: HAZARDOUS WASTES DESCRIBED BY MORE THAN ONE EPA HAZARDOUS WASTE NUMBER — Hazardous wastes that can be described by more than one EPA Hazardous Waste Number shall be described on the form as follows:

- Select one of the EPA Hazardous Waste Numbers and enter it in column A. On the same line complete columns B, C, and D by estimating the total annual quantity of the waste and describing all the processes to be used to treat, store, or dispose of the waste.
- In column A of the next line enter the other EPA Hazardous Waste Number that can be used to describe the waste. In column D(2) on that line enter "included with above" and make no other entries on that line.
- Repeat step 2 for each other EPA Hazardous Waste Number that can be used to describe the hazardous waste.

EXAMPLE FOR COMPLETING ITEM IV (shown in line numbers X-1, X-2, X-3, and X-4 below) — A facility will treat and dispose of an estimated 900 pounds per year of chrome shavings from leather tanning and finishing operation. In addition, the facility will treat and dispose of three non-listed wastes. Two wastes are corrosive only and there will be an estimated 200 pounds per year of each waste. The other waste is corrosive and ignitable and there will be an estimated 100 pounds per year of that waste. Treatment will be in an incinerator and disposal will be in a landfill.

LINE NO.	A. EPA HAZARD. WASTE NO. (enter code)	B. ESTIMATED ANNUAL QUANTITY OF WASTE	C. UNIT OF MEASURE (enter code)	D. PROCESSES	
				1. PROCESS CODES (enter)	2. PROCESS DESCRIPTION (if a code is not entered in D(1))
X-1	K 0 5 4	900	P	T 0 3 D 8 0	
X-2	0 1 0 0	400	P	T 0 3 D 8 0	
X-3	0 1 0 0	100	P	T 0 3 D 8 0	
X-4	1 0 0 0				included with above

Continued from page 2.

NOTE: Photocopy this page before completing if you have more than 26 wastes to list.

Form Approved OMB No. 158-S80004

EPA I.D. NUMBER (enter from page 1)										FOR OFFICIAL USE ONLY									
W										W									
1										2									
IV. DESCRIPTION OF HAZARDOUS WASTES (continued)																			
LINE NO.	A. EPA HAZARD. WASTE NO. (enter code)	B. ESTIMATED ANNUAL QUANTITY OF WASTE	C. UNIT OF MEASURE (enter code)	D. PROCESSES															
				1. PROCESS CODES (enter)								2. PROCESS DESCRIPTION (if a code is not entered in D(1))							
1																			
2																			
3																			
4																			
5																			
6																			
7																			
8																			
9																			
10																			
11																			
12																			
13																			
14																			
15																			
16																			
17																			
18																			
19																			
20																			
21																			
22																			
23																			
24																			
25																			
26																			

Continued from the front.

IV. DESCRIPTION OF HAZARDOUS WASTES (continued)

E. USE THIS SPACE TO LIST ADDITIONAL PROCESS CODES FROM ITEM B(1) ON PAGE 3.

EPA I.D. NO. (enter from page 1)											
8	9	10	11	12	13	14	15	16	17	18	19
F											20
											6

V. FACILITY DRAWING

All existing facilities must include in the space provided on page 5 a scale drawing of the facility *see instructions for more detail*.

VI. PHOTOGRAPHS

All existing facilities must include photographs (aerial or ground-level) that clearly delineate all existing structures; existing storage, treatment and disposal areas; and sites of future storage, treatment or disposal areas *(see instructions for more detail)*.

VII. FACILITY GEOGRAPHIC LOCATION

LATITUDE (degrees, minutes, & seconds)

LONGITUDE (degrees, minutes, & seconds)

01	02	03	04	05	06	07	08	09	10

11	12	13	14	15	16	17

VIII. FACILITY OWNER

A. If the facility owner is also the facility operator as listed in Section VIII on Form 1, "General Information", place an "X" in the box to the left and skip to Section IX below.

B. If the facility owner is not the facility operator as listed in Section VIII on Form 1, complete the following items:

1. NAME OF FACILITY'S LEGAL OWNER				2. PHONE NO. (area code & no.)			
D				E			
3. STREET OR P.O. BOX		4. CITY OR TOWN		5. ST.	6. ZIP CODE		
E		F					

IX. OWNER CERTIFICATION

I certify under penalty of law that I have personally examined and am familiar with the information submitted in this and all attached documents, and that based on my inquiry of those individuals immediately responsible for obtaining the information, I believe that the submitted information is true, accurate, and complete. I am aware that there are significant penalties for submitting false information, including the possibility of fine and imprisonment.

A. NAME (print or type)	B. SIGNATURE	C. DATE SIGNED

X. OPERATOR CERTIFICATION

I certify under penalty of law that I have personally examined and am familiar with the information submitted in this and all attached documents, and that based on my inquiry of those individuals immediately responsible for obtaining the information, I believe that the submitted information is true, accurate, and complete. I am aware that there are significant penalties for submitting false information, including the possibility of fine and imprisonment.

A. NAME (print or type)	B. SIGNATURE	C. DATE SIGNED

Continued from page 4.

Form Approved OMB No. 158-S80004

V FACILITY DRAWING (see page 4)

S
A
M
P
L
E