

## CHAPTER 126 APPENDIX A

### CAPTURE EFFICIENCY TEST PROCEDURES

#### VOC CAPTURE EFFICIENCY

##### Procedure F.1 - Fugitive VOC Emissions from Temporary Enclosures

### 1. INTRODUCTION

**1.1 Applicability.** This procedure is applicable for determining the fugitive volatile organic compounds (VOC) emissions from a temporary total enclosure (TTE). It is intended to be used as a segment in the development of liquid/gas or gas/gas protocols for determining VOC capture efficiency (CE) for surface coating and printing operations.

**1.2 Principle.** The amount of fugitive VOC emissions (F) from the TTE is calculated as the sum of the products of the VOC content ( $C_{Fj}$ ), the flow rate ( $Q_{Fj}$ ), and the sampling time ( $t_F$ ) from each fugitive emissions point.

**1.3 Estimated Measurement Uncertainty.** The measurement uncertainties are estimated for each fugitive emission point as follows:  $Q_{Fj} = \pm 5.5$  percent and  $CFj = \pm 5.0$  percent. Based on these numbers, the probable uncertainty for F is estimated at about  $\pm 7.4$  percent.

**1.4 Sampling Requirements.** A capture efficiency test shall consist of at least three sampling runs. The sampling time for each run should be at least 8 hours, unless otherwise approved.

**1.5 Notes.** Because this procedure is often applied in highly explosive areas, caution and care should be exercised in choosing appropriate equipment and installing and using the equipment. Mention of trade names or company products does not constitute endorsement. All gas concentrations (percent, ppm) are by volume, unless otherwise noted.

### 2. APPARATUS AND REAGENTS

**2.1 Gas VOC Concentration.** A schematic of the measurement system is shown in Figure 1. The main components are described below:

**2.1.1 Sample Probe.** Stainless steel, or equivalent. The probe shall be heated to prevent VOC condensation.

**2.1.2 Calibration Valve Assembly.** Three-way valve assembly at the outlet of sample probe to direct the zero and calibration gases to the analyzer. Other methods, such as quick-connect lines, to route calibration gases to the outlet of the sample probe are acceptable.

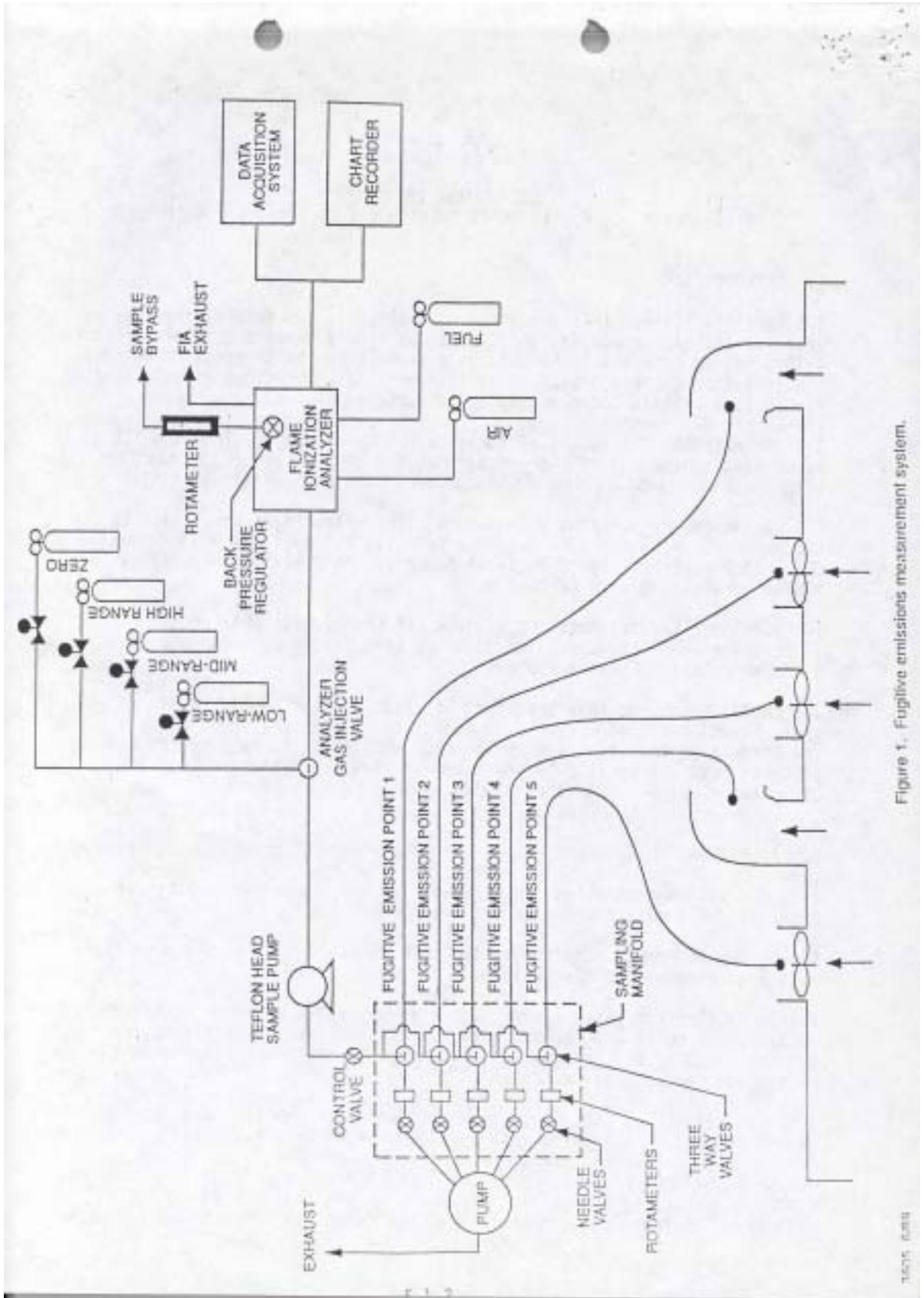

Figure 1. Fugitive emissions measurement system.

TR-05 6/2/88

**2.1.3 Sample line.** Stainless steel or Teflon tubing to transport the sample gas to the analyzer. The sample line must be heated to prevent condensation.

**2.1.4 Sample Pump.** A leak-free pump, to pull the sample gas through the system at a flow rate sufficient to minimize the response time of the measurement system. The components of the pump that contact the gas stream shall be constructed of stainless steel or Teflon. The sample pump must be heated to prevent condensation.

**2.1.5 Sample Flow Rate Control.** A sample flow rate control valve and rotameter, or equivalent, to maintain a constant sampling rate within 10 percent. The flow control valve and rotameter must be heated to prevent condensation. A control valve may also be located on the sample pump bypass loop to assist in controlling the sample pressure and flow rate.

**2.1.6 Sample Gas Manifold.** Capable of diverting a portion of the sample gas stream to the flame ionization analyzer (FIA), and the remainder to the bypass discharge vent. The manifold components shall be constructed of stainless steel or Teflon. If emissions are to be measured at multiple locations, the measurement system shall be designed to use separate sampling probes, lines, and pumps for each measurement location and a common sample gas manifold and FIA. The sample gas manifold and connecting lines to the FIA must be heated to prevent condensation.

**2.1.7 Organic Concentration Analyzer.** An FIA with a span value of 1.5 times the expected concentration as propane; however, other span values may be used if it can be demonstrated that they would provide more accurate measurements. The system shall be capable of meeting or exceeding the following specifications:

**2.1.7.1 Zero Drift.** Less than  $\pm 3.0$  percent of the span value.

**2.1.7.2 Calibration Drift.** Less than  $\pm 3.0$  percent of the span value.

**2.1.7.3 Calibration Error.** Less than  $\pm 5.0$  percent of the calibration gas value.

**2.1.7.4 Response Time.** Less than 30 seconds.

**2.1.8 Integrator/Data Acquisition System.** An analog or digital device or computerized data acquisition system used to integrate the FIA response or compute the average response and record measurement data. The minimum data sampling frequency for computing average or integrated values is one measurement value every 5 seconds. The device shall be capable of recording average values at least once per minute.

**2.1.9 Calibration and Other Gases.** Gases used for calibration, fuel, and combustion air (if required) are contained in compressed gas cylinders. All calibration gases shall be traceable to NIST standards and shall be certified by the manufacturer to  $\pm 1$  percent of the tag value. Additionally, the manufacturer of the cylinder should provide a recommended shelf life for each calibration gas cylinder over which the concentration does not change more than  $\pm 2$  percent from

the certified value. For calibration gas values not generally available, alternative methods for preparing calibration gas mixtures, such as dilution systems, may be used with prior approval.

**2.1.9.1 Fuel.** A 40 percent H<sub>2</sub>/60 percent He or 40 percent H<sub>2</sub>/60 percent N<sub>2</sub> gas mixture is recommended to avoid an oxygen synergism effect that reportedly occurs when oxygen concentration varies significantly from a mean value.

**2.1.9.2 Carrier Gas.** High purity air with less than 1 ppm of organic material (as propane or carbon equivalent) or less than 0.1 percent of the span value, whichever is greater.

**2.1.9.3 FIA Linearity Calibration Gases.** Low-, mid-, and high-range gas mixture standards with nominal propane concentrations of 20-30, 45-55, and 70-80 percent of the span value in air, respectively. Other calibration values and other span values may be used if it can be shown that more accurate measurements would be achieved.

**2.1.10 Particulate Filter.** An in-stack or an out-of-stack glass fiber filter is recommended if exhaust gas particulate loading is significant. An out-of-stack filter must be heated to prevent any condensation unless it can be demonstrated that no condensation occurs.

## **2.2 Fugitive Emissions Volumetric Flow Rate.**

**2.2.1 Method 2 or 2A Apparatus.** For determining volumetric flow rate.

**2.2.2 Method 3 Apparatus and Reagents.** For determining molecular weight of the gas stream. An estimate of the molecular weight of the gas stream may be used if it can be justified.

**2.2.3 Method 4 Apparatus and Reagents.** For determining moisture content, if necessary.

**2.3 Temporary Total Enclosure.** The criteria for designing a TTE are discussed in Procedure T.

## **3. DETERMINATION OF VOLUMETRIC FLOW RATE OF FUGITIVE EMISSIONS**

**3.1** Locate all points where emissions are exhausted from the TTE. Using Method 1, determine the sampling points. Be sure to check each site for cyclonic or swirling flow.

**3.2** Measure the velocity at each sampling site at least once every hour during each sampling run using Method 2 or 2A.

## **4. DETERMINATION OF VOC CONTENT OF FUGITIVE EMISSIONS**

**4.1 Analysis Duration.** Measure the VOC responses at each fugitive emission point during the entire test run or, if applicable, while the process is operating. If there are multiple emission

locations, design a sampling system to allow a single FIA to be used to determine the VOC responses at all sampling locations.

## **4.2 Gas VOC Concentration.**

**4.2.1** Assemble the sample train as shown in Figure 1. Calibrate the FIA and conduct a system check according to the procedures in Sections 5.1 and 5.3, respectively.

**4.2.2** Install the sample probe so that the probe is centrally located in the stack, pipe, or duct, and is sealed tightly at the stack port connection.

**4.2.3** Inject zero gas at the calibration valve assembly. Allow the measurement system response to reach zero. Measure the system response time as the time required for the system to reach the effluent concentration after the calibration valve has been returned to the effluent sampling position.

**4.2.4** Conduct a system check before and a system drift check after each sampling run according to the procedures in Sections 5.2 and 5.3. If the drift check following a run indicates unacceptable performance, the run is not valid. The tester may elect to perform system drift checks during the run not to exceed one drift check per hour.

**4.2.5** Verify that the sample lines, filter, and pump temperatures are  $120 \pm 5^{\circ}\text{C}$ .

**4.2.6** Begin sampling at the start of the test period and continue to sample during the entire run. Record the starting and ending times and any required process information as appropriate. If multiple emission locations are sampled using a single FIA, sample at each location for the same amount of time (e.g., 2 minutes) and continue to switch from one location to another for the entire test run. Be sure that total sampling time at each location is the same at the end of the test run. Collect at least 4 separate measurements from each sample point during each hour of testing. Disregard the response measurements at each sampling location until two times the response time of the measurement system has elapsed. Continue sampling for at least 1 minute and record the concentration measurements.

## **4.3 Background Concentration.**

### **4.3.1 Determination of VOC Background Concentration.**

**4.3.1.1** Locate all NDO's of the TTE. A sampling point shall be centrally located outside of the TTE at 4 equivalent diameters from each NDO, if possible. If there are more than 6 NDO's, choose 6 sampling points evenly spaced among the NDO's.

**4.3.1.2** Assemble the sample train as shown in Figure 2. Calibrate the FIA and conduct a system check according to the procedures in Sections 5.1 and 5.3.

**4.3.1.3** Position the probe at the sampling location.

**4.3.1.4** Determine the response time, conduct the system check and sample according to the procedures described in Sections 4.2.3 to 4.2.6.

**4.4 Alternative Procedure.** The direct interface sampling and analysis procedure described in

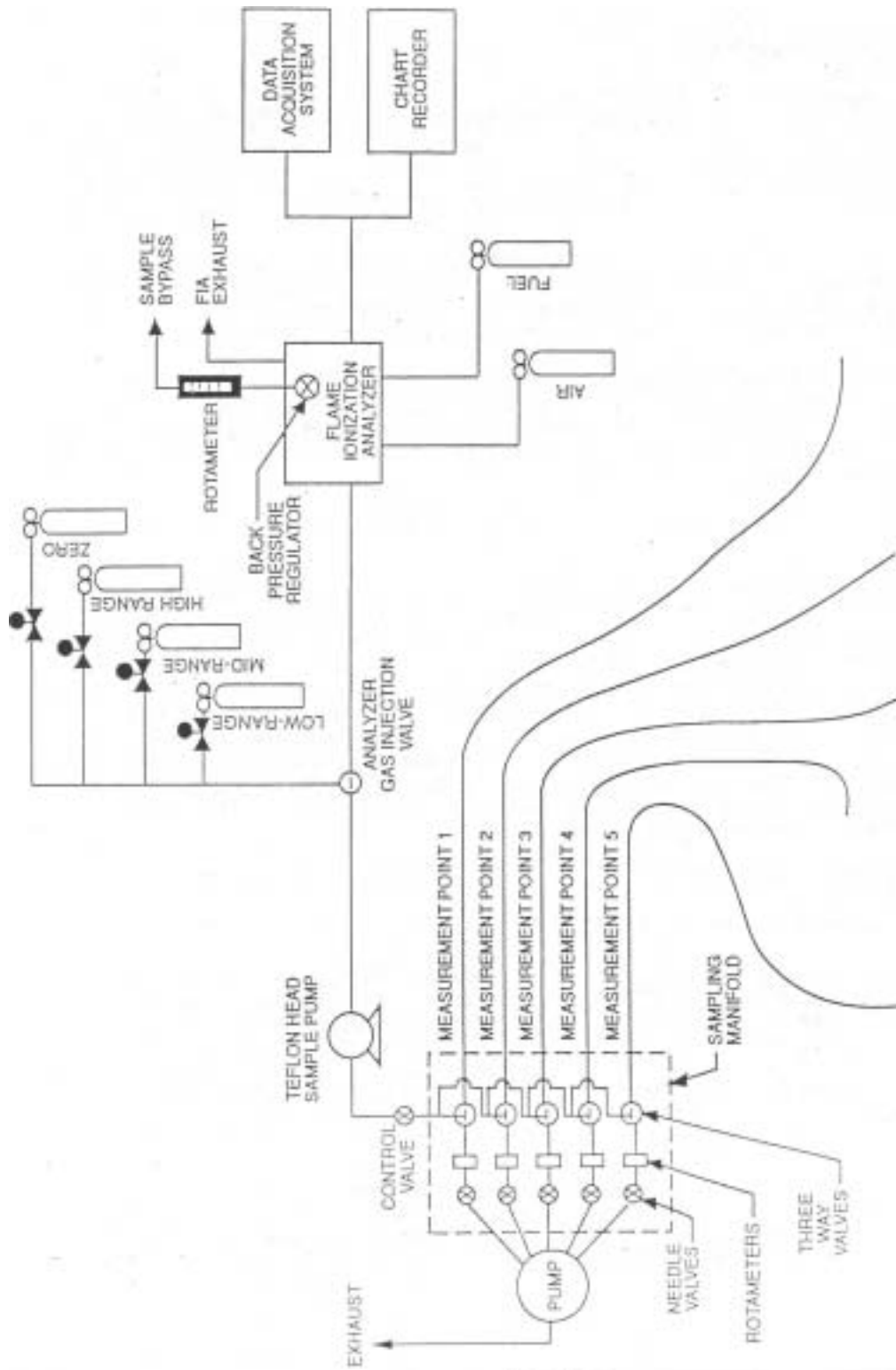

Figure 2. Background measurement system.

VOC 3/90



Section 7.2 of Method 18 may be used to determine the gas VOC concentration. The system must be designed to collect and analyze at least one sample every 10 minutes.

## 5. CALIBRATION AND QUALITY ASSURANCE

**5.1 FIA Calibration and Linearity Check.** Make necessary adjustments to the air and fuel supplies for the FIA and ignite the burner. Allow the FIA to warm up for the period recommended by the manufacturer. Inject a calibration gas into the measurement system and adjust the back-pressure regulator to the value required to achieve the flow rates specified by the manufacturer. Inject the zero- and the high-range calibration gases and adjust the analyzer calibration to provide the proper responses. Inject the low- and mid-range gases and record the responses of the measurement system. The calibration and linearity of the system are acceptable if the responses for all four gases are within 5 percent of the respective gas values. If the performance of the system is not acceptable, repair or adjust the system and repeat the linearity check. Conduct a calibration and linearity check after assembling the analysis system and after a major change is made to the system.

**5.2 Systems Drift Checks.** Select the calibration gas concentration that most closely approximates that of the fugitive gas emissions to conduct the drift checks. Introduce the zero and calibration gas at the calibration valve assembly and verify that the appropriate gas flow rate and pressure are present at the FIA. Record the measurement system responses to the zero and calibration gases. The performance of the system is acceptable if the difference between the drift check measurement and the value obtained in Section 5.1 is less than 3 percent of the span value. Conduct a system drift check at the end of each run.

**5.3 System Check.** Inject the high range calibration gas at the inlet of the sampling probe and record the response. The performance of the system is acceptable if the measurement system response is within 5 percent of the value obtained in Section 5.1 for the high range calibration gas. Conduct a system check before each test run.

**5.4 Analysis Audit.** Immediately before each test analyze an audit cylinder as described in Section 5.2. The analysis audit must agree with the audit cylinder concentration within 10 percent.

## 6. NOMENCLATURE

$A_i$  = area of NDO  $i$ , ft<sup>2</sup>.

$A_H$  = total area of all NDO's in the enclosure, ft<sup>2</sup>.

$C_{Bi}$  = corrected average VOC concentration of background emissions at point  $i$ , ppm propane.

$C_B$  = average background concentration, ppm propane.

$C_{DH}$  = average measured concentration for the drift check calibration gas, ppm propane.

$C_{DO}$  = average system drift check concentration for zero concentration gas,  
ppm propane.

$C_{Fj}$  = corrected average VOC concentration of fugitive emissions at point j,  
ppm propane.

$C_H$  = actual concentration of the drift check calibration gas, ppm propane.

$C_i$  = uncorrected average background VOC concentration at point i, ppm propane.

$C_j$  = uncorrected average VOC concentration measured at point j, ppm propane.

$F$  = total VOC content of fugitive emissions, kg.

$K_1$  =  $1.830 \times 10^{-6}$  kg/(m<sup>3</sup>-ppm).

$n$  = number of measurement points.

$Q_{Fj}$  = average effluent volumetric flow rate corrected to standard conditions at fugitive  
emissions point j, m<sup>3</sup>/min.

$F$  = total duration of fugitive emissions sampling run, min.

## 7. CALCULATIONS

### 7.1 Total VOC Fugitive Emissions.

$$F = \sum_{j=1}^n (C_{Fj} - C_B) Q_{Fj} F K_1 \quad \text{Eq. 1}$$

### 7.2 VOC Concentration of the Fugitive Emissions at Point j.

$$C_{Fj} = (C_j - C_{DO}) \frac{C_H}{C_{DH} - C_{DO}} \quad \text{Eq. 2}$$

### 7.3 Background VOC Concentration at Point i.

$$C_{Bi} = (C_i - C_{DO}) \frac{H}{DH - C_{DO}} C \quad \text{Eq. 3}$$

### 7.4 Average Background Concentration.

$$C_B = \frac{\sum_{i=1}^n C_{Bi} A_i}{n_H A} \quad \text{Eq. 4}$$

**NOTE:** If the concentration at each point is within 20 percent of the average concentration of all points, the terms "A<sub>i</sub>" and "A<sub>H</sub>" may be deleted from Equation 4.

## VOC CAPTURE EFFICIENCY

### Procedure F.2 - Fugitive VOC Emissions from Building Enclosures

#### 1. INTRODUCTION

**1.1 Applicability.** This procedure is applicable for determining the fugitive volatile organic compounds (VOC) emissions from a building enclosure (BE). It is intended to be used as a segment in the development of liquid/gas or gas/gas protocols for determining VOC capture efficiency (CE) for surface coating and printing operations.

**1.2 Principle.** The total amount of fugitive VOC emissions ( $F_B$ ) from the BE is calculated as the sum of the products of the VOC content ( $C_{Fj}$ ) of each fugitive emissions point, its flow rate ( $Q_{Fj}$ ), and time ( $t_F$ ).

**1.3 Measurement Uncertainty.** The measurement uncertainties are estimated for each fugitive emissions point as follows:  $Q_{Fj} = \pm 5.0$  percent and  $C_{Fj} = \pm 5.0$  percent. Based on these numbers, the probable uncertainty for  $F_B$  is estimated at about  $\pm 11.2$  percent.

**1.4 Sampling Requirements.** A capture efficiency test shall consist of at least three sampling runs. The sampling time for each run should be at least 8 hours, unless otherwise approved.

**1.5 Notes.** Because this procedure is often applied in highly explosive areas, caution and care should be exercised in choosing appropriate equipment and installing and using the equipment. Mention of trade names or company products does not constitute endorsement. All gas concentrations (percent, ppm) are by volume, unless otherwise noted.

#### 2. APPARATUS AND REAGENTS

**2.1 Gas VOC Concentration.** A schematic of the measurement system is shown in Figure 1. The main components are described below:

**2.1.1 Sample Probe.** Stainless steel, or equivalent. The probe shall be heated to prevent VOC condensation.

**2.1.2 Calibration Valve Assembly.** Three-way valve assembly at the outlet of sample probe to direct the zero and calibration gases to the analyzer. Other methods, such as quick-connect lines, to route calibration gases to the outlet of the sample probe are acceptable.

**2.1.3 Sample line.** Stainless steel or Teflon tubing to transport the sample gas to the analyzer. The sample line must be heated to prevent condensation.

**2.1.4 Sample Pump.** A leak-free pump, to pull the sample gas through the system at a flow rate

sufficient to minimize the response time of the measurement system. The components of the pump that contact the gas stream shall be constructed of stainless steel or Teflon. The sample

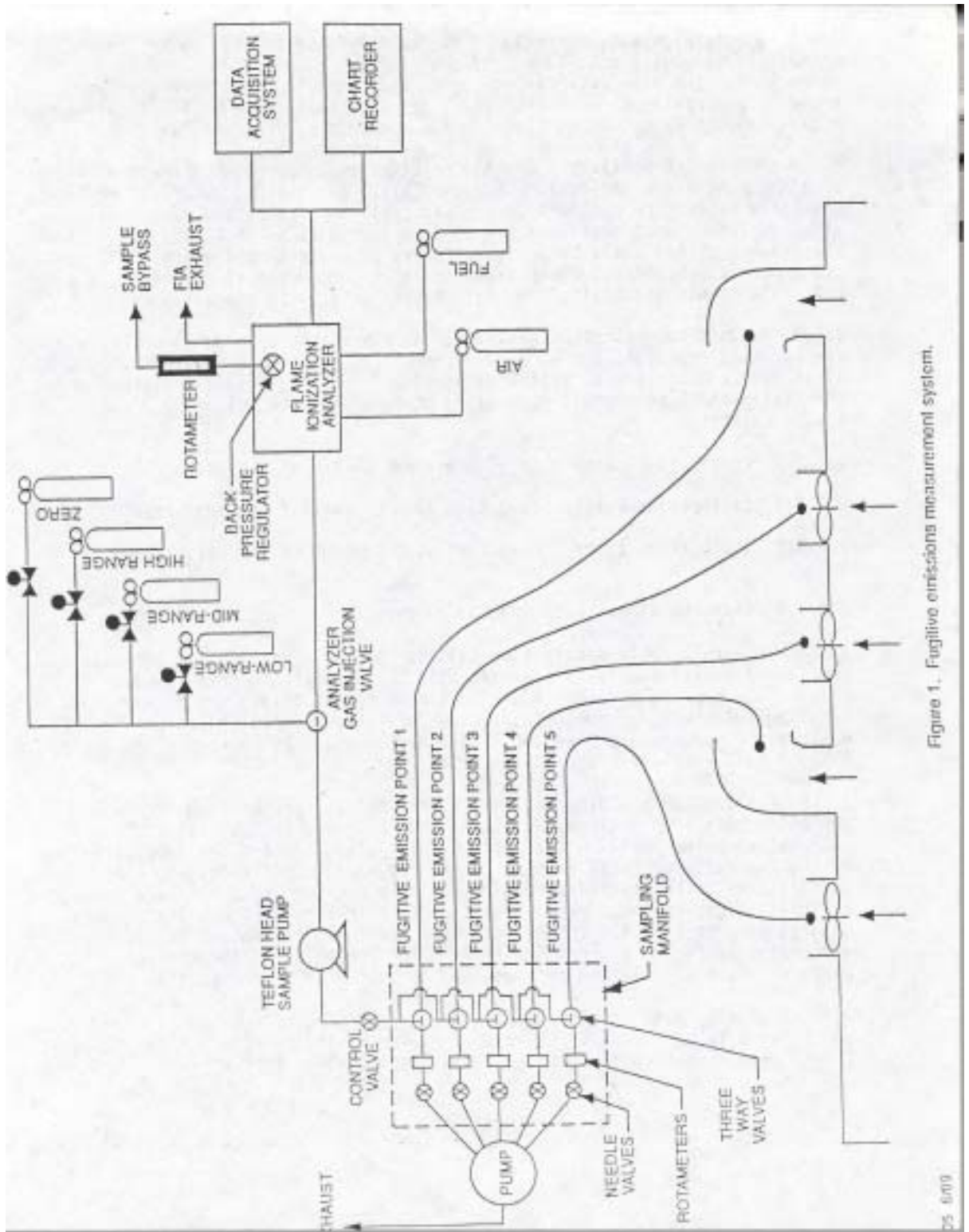

Figure 1. Fugitive emissions measurement system.

DS 6/09

pump must be heated to prevent condensation.

**2.1.5 Sample Flow Rate Control.** A sample flow rate control valve and rotameter, or equivalent, to maintain a constant sampling rate within 10 percent. The flow rate control valve and rotameter must be heated to prevent condensation. A control valve may also be located on the sample pump bypass loop to assist in controlling the sample pressure and flow rate.

**2.1.6 Sample Gas Manifold.** Capable of diverting a portion of the sample gas stream to the flame ionization analyzer (FIA), and the remainder to the bypass discharge vent. The manifold components shall be constructed of stainless steel or Teflon. If emissions are to be measured at multiple locations, the measurement system shall be designed to use separate sampling probes, lines, and pumps for each measurement location and a common sample gas manifold and FIA. The sample gas manifold must be heated to prevent condensation.

**2.1.7 Organic Concentration Analyzer.** An FIA with a span value of 1.5 times the expected concentration as propane; however, other span values may be used if it can be demonstrated that they would provide more accurate measurements. The system shall be capable of meeting or exceeding the following specifications:

**2.1.7.1 Zero Drift.** Less than  $\pm 3.0$  percent of the span value.

**2.1.7.2 Calibration Drift.** Less than  $\pm 3.0$  percent of the span value.

**2.1.7.3 Calibration Error.** Less than  $\pm 5.0$  percent of the calibration gas value.

**2.1.7.4 Response Time.** Less than 30 seconds.

**2.1.8 Integrator/Data Acquisition System.** An analog or digital device or computerized data acquisition system used to integrate the FIA response or compute the average response and record measurement data. The minimum data sampling frequency for computing average or integrated values is one measurement value every 5 seconds. The device shall be capable of recording average values at least once per minute.

**2.1.9 Calibration and Other Gases.** Gases used for calibration, fuel, and combustion air (if required) are contained in compressed gas cylinders. All calibration gases shall be traceable to NIST standards and shall be certified by the manufacturer to  $\pm 1$  percent of the tag value. Additionally, the manufacturer of the cylinder should provide a recommended shelf life for each calibration gas cylinder over which the concentration does not change more than  $\pm 2$  percent from the certified value. For calibration gas values not generally available, alternative methods for preparing calibration gas mixtures, such as dilution systems, may be used with prior approval.

**2.1.9.1 Fuel.** A 40 percent  $H_2$ /60 percent He or 40 percent  $H_2$ /60 percent  $N_2$  gas mixture is recommended to avoid an oxygen synergism effect that reportedly occurs when oxygen concentration varies significantly from a mean value.

**2.1.9.2 Carrier Gas.** High purity air with less than 1 ppm of organic material (propane or carbon equivalent) or less than 0.1 percent of the span value, whichever is greater.

**2.1.9.3 FIA Linearity Calibration Gases.** Low-, mid-, and high-range gas mixture standards with nominal propane concentrations of 20-30, 45-55, and 70-80 percent of the span value in air, respectively. Other calibration values and other span values may be used if it can be shown that more accurate measurements would be achieved.

**2.1.10 Particulate Filter.** An in-stack or an out-of-stack glass fiber filter is recommended if exhaust gas particulate loading is significant. An out-of-stack filter must be heated to prevent any condensation unless it can be demonstrated that no condensation occurs.

## **2.2 Fugitive Emissions Volumetric Flow Rate.**

**2.2.1 Flow Direction Indicators.** Any means of indicating inward or outward flow, such as light plastic film or paper streamers, smoke tubes, filaments, and sensory perception.

**2.2.2 Method 2 or 2A Apparatus.** For determining volumetric flow rate. Anemometers or similar devices calibrated according to the manufacturer's instructions may be used when low velocities are present. Vane anemometers (Young-maximum response propeller), specialized pitots with electronic manometers (e.g., Shortridge Instruments Inc., Airdata Multimeter 860) are commercially available with measurement thresholds of 15 and 8 mpm (50 and 25 fpm), respectively.

**2.2.3 Method 3 Apparatus and Reagents.** For determining molecular weight of the gas stream. An estimate of the molecular weight of the gas stream may be used if it can be justified.

**2.2.4 Method 4 Apparatus and Reagents.** For determining moisture content, if necessary.

## **3. DETERMINATION OF VOLUMETRIC FLOW RATE OF FUGITIVE EMISSIONS**

**3.1 Preliminary Determinations.** The purpose of this exercise is to determine which exhaust points should be measured for volumetric flow rates and VOC concentrations.

**3.1.1 Forced Draft Openings.** Identify all forced draft openings. Determine the volumetric flow rate according to Method 2.

**3.1.2 NDO's Exhaust Points.** The NDO's in the roof of a facility are considered to be exhaust points. Determine volumetric flow rate from these NDO's. Divide the cross-sectional area according to Method 1 using 12 equal areas. Use the appropriate velocity measurement devices, e.g., propeller anemometers.

**3.1.3 Other NDO's.**



**3.1.3.1** This step is optional. Determine the exhaust flow rate, including that of the control device, from the enclosure and the intake air flow rate. If the exhaust flow rate divided by the intake air flow rate is greater than 1.1, then all other NDO's are not considered to be significant exhaust points.

**3.1.3.2** If the option above is not taken, identify all other NDO's and other potential points through which fugitive emissions may escape the enclosure. Then use the following criteria to determine whether flow rates and VOC concentrations need to be measured:

**3.1.3.2.1** Using the appropriate flow direction indicator, determine the flow direction. An NDO with zero or inward flow is not an exhaust point.

**3.1.3.2.2** Measure the outward volumetric flow rate from the remainder of the NDO's. If the collective flow rate is 2 percent, or less, of the flow rate from Sections 3.1.1 and 3.1.2, then these NDO's, except those within two equivalent diameters (based on NDO opening) from VOC sources, may be considered to be non-exhaust points.

**3.1.3.2.3** If the percentage calculated in Section 3.1.3.2.2 is greater than 2 percent, those NDO's (except those within two equivalent diameters from VOC sources) whose volumetric flow rate total 2 percent of the flow rate from Sections 3.1.1 and 3.1.2 may be considered as non-exhaust points. All remaining NDO's shall be measured for volumetric flow rate and VOC concentrations during the CE test.

**3.1.3.2.4** The tester may choose to measure VOC concentrations at the forced exhaust points and the NDO's. If the total VOC emissions from the NDO's are less than 2 percent of the emissions from the forced draft and roof NDO's, then these NDO's may be eliminated from further consideration.

## **3.2 Determination of Flow Rates.**

**3.2.1** Measure the volumetric flow rate at all locations identified as exhaust points in Section 3.1. Divide each exhaust opening into 9 equal areas for rectangular openings and 8 for circular openings.

**3.2.2** Measure the velocity at each site at least once every hour during each sampling run using Method 2 or 2A, if applicable, or using the low velocity instruments in Section 2.2.2.

## **4. DETERMINATION OF VOC CONTENT OF FUGITIVE EMISSIONS**

**4.1 Analysis Duration.** Measure the VOC responses at each fugitive emission point during the entire test run or, if applicable, while the process is operating. If there are multiple emissions locations, design a sampling system to allow a single FIA to be used to determine the VOC responses at all sampling locations.

## **4.2 Gas VOC Concentration.**

**4.2.1** Assemble the sample train as shown in Figure 1. Calibrate the FIA and conduct a system check according to the procedures in Sections 5.1 and 5.3, respectively.

**4.2.2** Install the sample probe so that the probe is centrally located in the stack, pipe, or duct, and is sealed tightly at the stack port connection.

**4.2.3** Inject zero gas at the calibration valve assembly. Allow the measurement system response to reach zero. Measure the system response time as the time required for the system to reach the effluent concentration after the calibration valve has been returned to the effluent sampling position.

**4.2.4** Conduct a system check before and a system drift check after each sampling run according to the procedures in Sections 5.2 and 5.3. If the drift check following a run indicates unacceptable performance, the run is not valid. The tester may elect to perform drift checks during the run not to exceed one drift check per hour.

**4.2.5** Verify that the sample lines, filter, and pump temperatures are  $120 \pm 5^{\circ}\text{C}$ .

**4.2.6** Begin sampling at the start of the test period and continue to sample during the entire run. Record the starting and ending times and any required process information as appropriate. If multiple emission locations are sampled using a single FIA, sample at each location for the same amount of time (e.g., 2 minutes) and continue to switch from one location to another for the entire test run. Be sure that total sampling time at each location is the same at the end of the test run. Collect at least 4 separate measurements from each sample point during each hour of testing. Disregard the response measurements at each sampling location until two times the response time of the measurement system has elapsed. Continue sampling for at least 1 minute and record the concentration measurements.

**4.3 Alternative Procedure** The direct interface sampling and analysis procedure described in Section 7.2 of Method 18 may be used to determine the gas VOC concentration. The system must be designed to collect and analyze at least one sample every 10 minutes.

## **5. CALIBRATION AND QUALITY ASSURANCE**

**5.1 FIA Calibration and Linearity Check.** Make necessary adjustments to the air and fuel supplies for the FIA and ignite the burner. Allow the FIA to warm up for the period recommended by the manufacturer. Inject a calibration gas into the measurement system and adjust the back-pressure regulator to the value required to achieve the flow rates specified by the manufacturer. Inject the zero- and the high-range calibration gases and adjust the analyzer calibration to provide the proper responses. Inject the low- and mid-range gases and record the responses of the measurement system. The calibration and linearity of the system are acceptable if the responses for all four gases are within 5 percent of the respective gas values. If the

performance of the system is not acceptable, repair or adjust the system and repeat the linearity check. Conduct a calibration and linearity check after assembling the analysis system and after a major change is made to the system.

**5.2 Systems Drift Checks.** Select the calibration gas that most closely approximates the concentration of the captured emissions for conducting the drift checks. Introduce the zero and calibration gas at the calibration valve assembly and verify that the appropriate gas flow rate and pressure are present at the FIA. Record the measurement system responses to the zero and calibration gases. The performance of the system is acceptable if the difference between the drift check measurement and the value obtained in Section 5.1 is less than 3 percent of the span value. Conduct a system drift check at the end of each run.

**5.3 System Check.** Inject the high range calibration gas at the inlet of the sampling probe and record the response. The performance of the system is acceptable if the measurement system response is within 5 percent of the value obtained in Section 5.1 for the high range calibration gas. Conduct a system check before each test run.

**5.4 Analysis Audit.** Immediately before each test analyze an audit cylinder as described in Section 5.2. The analysis audit must agree with the audit cylinder concentration within 10 percent.

## 6. NOMENCLATURE

$C_{DH}$  = average measured concentration for the drift check calibration gas, ppm propane.

$C_{DO}$  = average system drift check concentration for zero concentration gas, ppm propane.

$C_{Fj}$  = corrected average VOC concentration of fugitive emissions at point j, ppm propane.

$C_H$  = actual concentration of the drift check calibration gas, ppm propane.

$C_j$  = uncorrected average VOC concentration measured at point j, ppm propane.

$F_B$  = total VOC content of fugitive emissions from the building, kg.

$K_1$  =  $1.830 \times 10^{-6}$  kg/(m<sup>3</sup>-ppm).

$n$  = number of measurement points.

$Q_{Fj}$  = average effluent volumetric flow rate corrected to standard conditions at fugitive emissions point j, m<sup>3</sup>/min.

$F$  = total duration of capture efficiency sampling run, min.

## 7. CALCULATIONS

### 7.1 Total VOC Fugitive Emissions From the Building.

$$F_B = \sum_{j=1}^n C_{Fj} Q_{Fj} \quad \text{Eq. 1}$$

### 7.2 VOC Concentration of the Fugitive Emissions at Point j.

$$C_{Fj} = (C_j - C_{DO}) \frac{H}{DH - C_{DO}} \quad \text{Eq. 2}$$

# VOC CAPTURE EFFICIENCY

## Procedure G.1 - Captured VOC Emissions

### 1. INTRODUCTION

**1.1 Applicability.** This procedure is applicable for determining the volatile organic compounds (VOC) content of captured gas streams. It is intended to be used as a segment in the development of liquid/gas or gas/gas protocols for determining VOC capture efficiency (CE) for surface coating and printing operations. The procedure may not be acceptable in certain site-specific situations, e.g., when: (1) direct fired heaters or other circumstances affect the quantity of VOC at the control device inlet; and (2) particulate organic aerosols are formed in the process and are present in the captured emissions.

**1.2 Principle.** The amount of VOC captured ( $G$ ) is calculated as the sum of the products of the VOC content ( $C_{Gj}$ ), the flow rate ( $Q_{Gj}$ ), and the sample time ( $t_j$ ) from each captured emissions point.

**1.3 Estimated Measurement Uncertainty.** The measurement uncertainties are estimated for each captured or fugitive emissions point as follows:  $Q_{Gj} = \pm 5.5$  percent and  $C_{Gj} = \pm 5.0$  percent. Based on these numbers, the probable uncertainty for  $G$  is estimated at about  $\pm 7.4$  percent.

**1.4 Sampling Requirements.** A capture efficiency test shall consist of at least three sampling runs. The sampling time for each run should be at least 8 hours, unless otherwise approved.

**1.5 Notes.** Because this procedure is often applied in highly explosive areas, caution and care should be exercised in choosing appropriate equipment and installing and using the equipment. Mention of trade names or company products does not constitute endorsement. All gas concentrations (percent, ppm) are by volume, unless otherwise noted.

### 2. APPARATUS AND REAGENTS

**2.1 Gas VOC Concentration.** A schematic of the measurement system is shown in Figure 1. The main components are described below:

**2.1.1 Sample Probe.** Stainless steel, or equivalent. The probe shall be heated to prevent VOC condensation.

**2.1.2 Calibration Valve Assembly.** Three-way valve assembly at the outlet of sample probe to direct the zero and calibration gases to the analyzer. Other methods, such as quick-connect lines, to route calibration gases to the outlet of the sample probe are acceptable.

**2.1.3 Sample Line.** Stainless steel or Teflon tubing to transport the sample gas to the analyzer.

The sample line must be heated to prevent condensation.

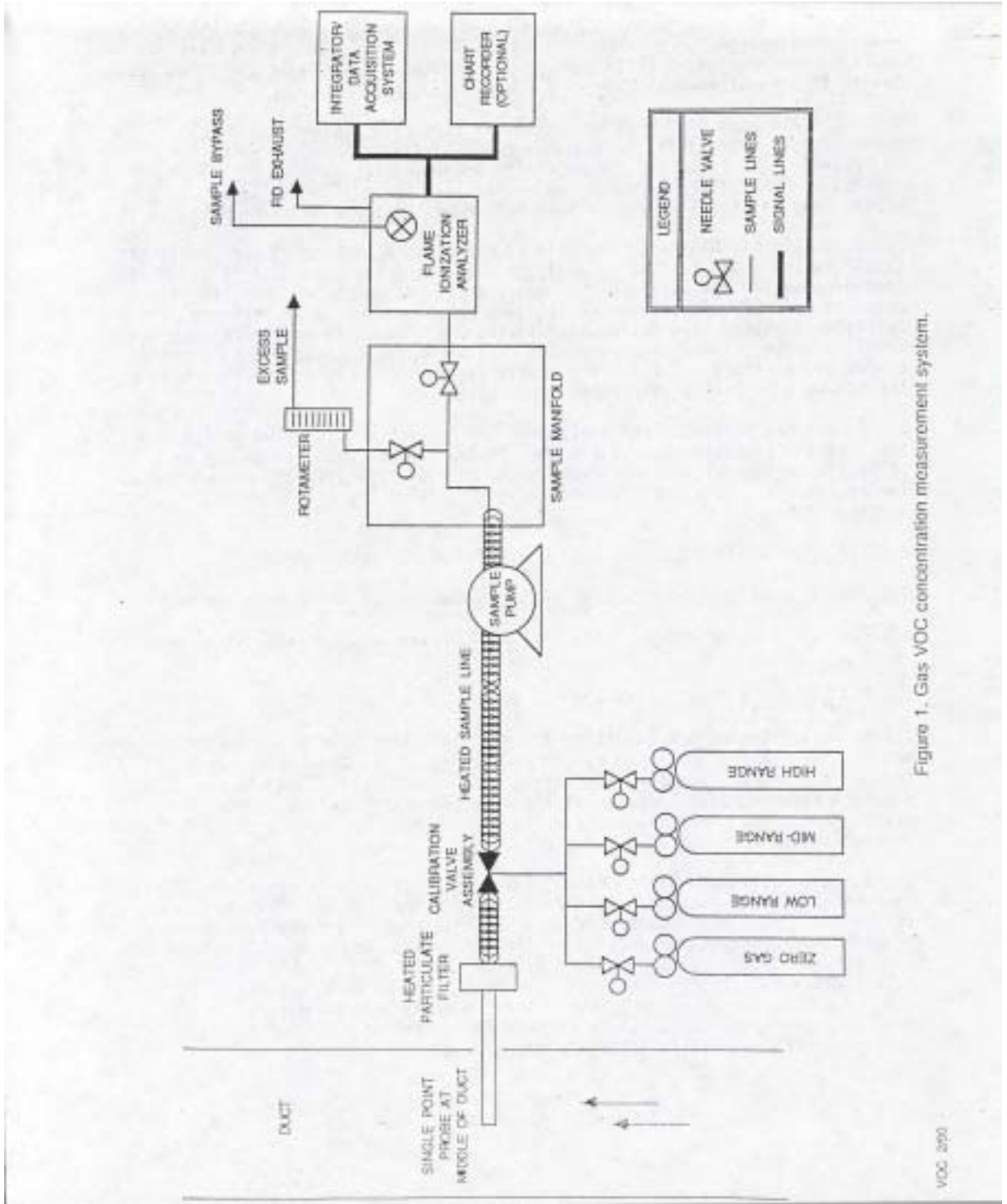

Figure 1. Gas VOC concentration measurement system.

**2.1.4 Sample Pump.** A leak-free pump, to pull the sample gas through the system at a flow rate sufficient to minimize the response time of the measurement system. The components of the pump that contact the gas stream shall be constructed of stainless steel or Teflon. The sample pump must be heated to prevent condensation.

**2.1.5 Sample Flow Rate Control.** A sample flow rate control valve and rotameter, or equivalent, to maintain a constant sampling rate within 10 percent. The flow rate control valve and rotameter must be heated to prevent condensation. A control valve may also be located on the sample pump bypass loop to assist in controlling the sample pressure and flow rate.

**2.1.6. Sample Gas Manifold.** Capable of diverting a portion of the sample gas stream to the flame ionization analyzer (FIA), and the remainder to the bypass discharge vent. The manifold components shall be constructed of stainless steel or Teflon. If captured or fugitive emissions are to be measured at multiple locations, the measurement system shall be designed to use separate sampling probes, lines, and pumps for each measurement location and a common sample gas manifold and FIA. The sample gas manifold and connecting lines to the FIA must be heated to prevent condensation.

**2.1.7 Organic Concentration Analyzer.** An FIA with a span value of 1.5 times the expected concentration as propane; however, other span values may be used if it can be demonstrated that they would provide more accurate measurements. The system shall be capable of meeting or exceeding the following specifications:

**2.1.7.1 Zero Drift.** Less than  $\pm 3.0$  percent of the span value.

**2.1.7.2 Calibration Drift.** Less than  $\pm 3.0$  percent of the span value.

**2.1.7.3 Calibration Error.** Less than  $\pm 5.0$  percent of the calibration gas value.

**2.1.7.4 Response Time.** Less than 30 seconds.

**2.1.8 Integrator/Data Acquisition System.** An analog or digital device or computerized data acquisition system used to integrate the FIA response or compute the average response and record measurement data. The minimum data sampling frequency for computing average or integrated values is one measurement value every 5 seconds. The device shall be capable of recording average values at least once per minute.

**2.1.9 Calibration and Other Gases.** Gases used for calibration, fuel, and combustion air {if required) are contained in compressed gas cylinders. All calibration gases shall be traceable to NIST standards and shall be certified by the manufacturer to  $\pm 1$  percent of the tag value. Additionally, the manufacturer of the cylinder should provide a recommended shelf life for each calibration gas cylinder over which the concentration does not change more than  $\pm 2$  percent from the certified value. For calibration gas values not generally available, alternative methods for preparing calibration gas mixtures, such as dilution systems, may be used with prior approval.



**2.1.9.1 Fuel.** A 40 percent H<sub>2</sub>/60 percent He or 40 percent H<sub>2</sub>/60 percent N<sub>2</sub> gas mixture is recommended to avoid an oxygen synergism effect that reportedly occurs when oxygen concentration varies significantly from a mean value.

**2.1.9.2 Carrier Gas.** High purity air with less than 1 ppm of organic material (as propane or carbon equivalent) or less than 0.1 percent of the span value, whichever is greater.

**2.1.9.3 FIA Linearity Calibration Gases.** Low-, mid-, and high-range gas mixture standards with nominal propane concentrations of 20-30, 45-55, and 70-80 percent of the span value in air, respectively. Other calibration values and other span values may be used if it can be shown that more accurate measurements would be achieved.

**2.1.10 Particulate Filter.** An in-stack or an out-of-stack glass fiber filter is recommended if exhaust gas particulate loading is significant. An out-of-stack filter must be heated to prevent any condensation unless it can be demonstrated that no condensation occurs.

## **2.2 Captured Emissions Volumetric Flow Rate.**

**2.2.1 Method 2 or 2A Apparatus.** For determining volumetric flow rate.

**2.2.2 Method 3 Apparatus and Reagents.** For determining molecular weight of the gas stream. An estimate of the molecular weight of the gas stream may be used if it can be justified.

**2.2.3 Method 4 Apparatus and Reagents.** For determining moisture content, if necessary.

## **3. DETERMINATION OF VOLUMETRIC FLOW RATE OF CAPTURED EMISSIONS**

**3.1** Locate all points where emissions are captured from the affected facility. Using Method 1, determine the sampling points. Be sure to check each site for cyclonic or swirling flow.

**3.2** Measure the velocity at each sampling site at least once every hour during each sampling run using Method 2 or 2A.

## **4. DETERMINATION OF VOC CONTENT OF CAPTURED EMISSIONS.**

**4.1 Analysis Duration.** Measure the VOC responses at each captured emissions point during the entire test run or, if applicable, while the process is operating. If there are multiple captured emission locations, design a sampling system to allow a single FIA to be used to determine the VOC responses at all sampling locations.

### **4.2 Gas VOC Concentration.**

**4.2.1** Assemble the sample train as shown in Figure 1. Calibrate the FIA according to the

procedure in Section 5.1.

**4.2.2** Conduct a system check according to the procedure in Section 5.3.

**4.2.3** Install the sample probe so that the probe is centrally located in the stack, pipe, or duct, and is sealed tightly at the stack port connection.

**4.2.4** Inject zero gas at the calibration valve assembly. Allow the measurement system response to reach zero. Measure the system response time as the time required for the system to reach the effluent concentration after the calibration valve has been returned to the effluent sampling position.

**4.2.5** Conduct a system check before and a system drift check after each sampling run according to the procedures in Sections 5.2 and 5.3. If the drift check following a run indicates unacceptable performance, the run is not valid. The tester may elect to perform system drift checks during the run not to exceed one drift check per hour.

**4.2.6** Verify that the sample lines, filter, and pump temperatures are  $120 \pm 5^{\circ}\text{C}$ .

**4.2.7** Begin sampling at the start of the test period and continue to sample during the entire run. Record the starting and ending times and any required process information as appropriate. If multiple captured emission locations are sampled using a single FIA, sample at each location for the same amount of time (e.g., 2 minutes) and continue to switch from one location to another for the entire test run. Be sure that total sampling time at each location is the same at the end of the test run. Collect at least 4 separate measurements from each sample point during each hour of testing. Disregard the measurements at each sampling location until two times the response time of the measurement system has elapsed. Continue sampling for at least 1 minute and record the concentration measurements.

### **4.3 Background Concentration.**

**4.3.1** Locate all NDO's of the TTE. A sampling point shall be centrally located outside of the TTE at 4 equivalent diameters from each NDO, if possible. If there are more than 6 NDO's, choose 6 sampling points evenly spaced among the NDO's.

**4.3.2** Assemble the sample train as shown in Figure 2. Calibrate the FIA and conduct a system check according to the procedures in Sections 5.1 and 5.3. **NOTE:** This sample train shall be a separate sampling train from the one to measure the captured emissions.

**4.3.3** Position the probe at the sampling location.

**4.3.4** Determine the response time, conduct the system check and sample according to the procedures described in Sections 4.2.4 to 4.2.7.

**4.4 Alternative Procedure.** The direct interface sampling and analysis procedure described in

Section 7.2 of Method 18 may be used to determine the gas VOC concentration. The system must be designed to collect and analyze at least one sample every 10 minutes.

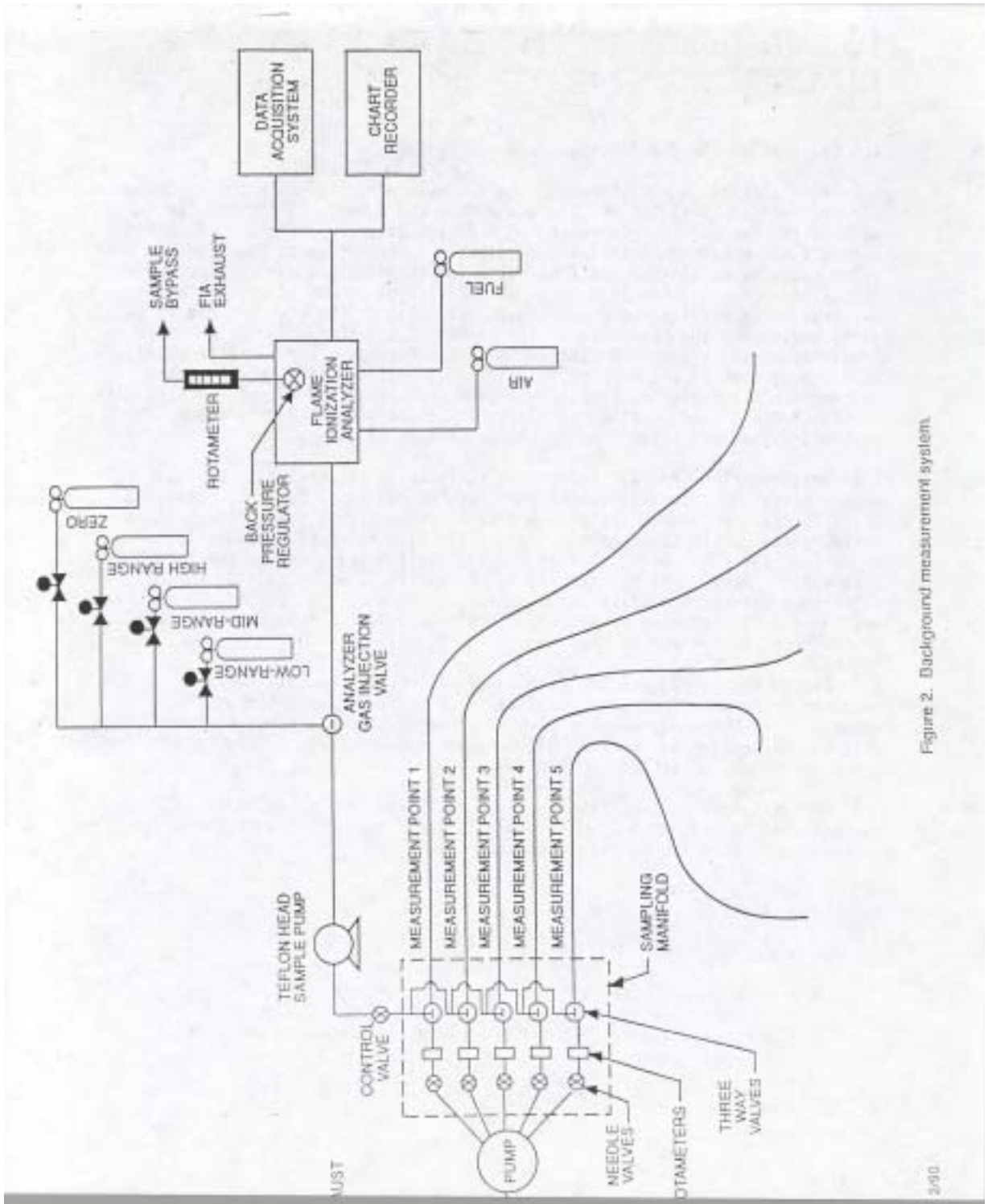

Figure 2. Background measurement system.

## 5. CALIBRATION AND QUALITY ASSURANCE

**5.1 FIA Calibration and Linearity Check.** Make necessary adjustments to the air and fuel supplies for the FIA and ignite the burner. Allow the FIA to warm up for the period recommended by the manufacturer. Inject a calibration gas into the measurement system and adjust the back-pressure regulator to the value required to achieve the flow rates specified by the manufacturer. Inject the zero- and the high-range calibration gases and adjust the analyzer calibration to provide the proper responses. Inject the low- and mid-range gases and record the responses of the measurement system. The calibration and linearity of the system are acceptable if the responses for all four gases are within 5 percent of the respective gas values. If the performance of the system is not acceptable, repair or adjust the system and repeat the linearity check. Conduct a calibration and linearity check after assembling the analysis system and after a major change is made to the system.

**5.2 Systems Drift Checks.** Select the calibration gas that most closely approximates the concentration of the captured emissions for conducting the drift checks. Introduce the zero and calibration gas at the calibration valve assembly and verify that the appropriate gas flow rate and pressure are present at the FIA. Record the measurement system responses to the zero and calibration gases. The performance of the system is acceptable if the difference between the drift check measurement and the value obtained in Section 5.1 is less than 3 percent of the span value. Conduct the system drift checks at the end of each run.

**5.3 System Check.** Inject the high range calibration gas at the inlet of the sampling probe and record the response. The performance of the system is acceptable if the measurement system response is within 5 percent of the value obtained in Section 5.1 for the high range calibration gas. Conduct a system check before and after each test run.

**5.4 Analysis Audit.** Immediately before each test analyze an audit cylinder as described in Section 5.2. The analysis audit must agree with the audit cylinder concentration within 10 percent.

## 6. NOMENCLATURE

$A_i$  = area of NDO  $i$ , ft<sup>2</sup>.

$A_H$  = total area of all NDO's in the enclosure, ft<sup>2</sup>.

$C_{Bi}$  = corrected average VOC concentration of background emissions at point  $i$ , ppm propane.

$C_B$  = average background concentration, ppm propane.

$C_{Gj}$  = corrected average VOC concentration of captured emissions at point  $j$ ,

ppm propane.

$C_{DH}$  = average measured concentration for the drift check calibration gas, ppm propane.

$C_{DO}$  = average system drift check concentration for zero concentration gas, ppm propane.

$C_H$  = actual concentration of the drift check calibration gas, ppm propane.

$C_i$  = uncorrected average background VOC concentration at point i, ppm propane.

$C_j$  = uncorrected average VOC concentration measured at point j, ppm propane.

$G$  = total VOC content of captured emissions, kg.

$K_1$  =  $1.830 \times 10^{-6}$  kg/(m<sup>3</sup>-ppm).

$n$  = number of measurement points.

$Q_{Gj}$  = average effluent volumetric flow rate corrected to standard conditions at captured emissions point j, m<sup>3</sup>/min.

$c$  = total duration of captured emissions sampling run, min.

## 7. CALCULATIONS

### 7.1 Total VOC Captured Emissions.

$$G = \sum_{j=1}^n (C_{Gj} - C_B) Q_{Gj} c K_1 \quad \text{Eq. 1}$$

### 7.2 VOC Concentration of the Captured Emissions at Point j.

$$C_{Gj} = (C_j - C_{DO}) \frac{C_H}{C_{DH} - C_{DO}} \quad \text{Eq. 2}$$

### 7.3 Background VOC Concentration at Point i.

$$C_{Bi} = (C_i - C_{DO}) \frac{H}{DH - C_{DO}} C \quad \text{Eq. 3}$$

### 7.4 Average Background Concentration.

$$C_B = \frac{\sum_{i=1}^n C_{Bi} A_i}{n_H A} \quad \text{Eq. 4}$$

**NOTE:** If the concentration at each point is within 20 percent of the average concentration of all points, the terms "A<sub>i</sub>" and "A<sub>H</sub>" may be deleted from Equation 4.

## VOC CAPTURE EFFICIENCY

### Procedure G.2 - Captured VOC Emissions (Dilution Technique)

#### 1. INTRODUCTION

**1.1 Applicability.** This procedure is applicable for determining the volatile organic compounds (VOC) content of captured gas streams. It is intended to be used as a segment in the development of a gas/gas protocol in which fugitive emissions are measured for determining VOC capture efficiency (CE) for surface coating and printing operations. A dilution system is used to reduce the VOC concentration of the captured emission to about the same concentration as the fugitive emissions. The procedure may not be acceptable in certain site-specific situations, e.g., when: (1) direct fired heaters or other circumstances affect the quantity of VOC at the control device inlet; and (2) particulate organic aerosols are formed in the process and are present in the captured emissions.

**1.2 Principle.** The amount of VOC captured ( $G$ ) is calculated as the sum of the products of the VOC content ( $C_{Gj}$ ), the flow rate ( $Q_{Gj}$ ), and the sampling time ( $t_c$ ) from each captured emissions point.

**1.3 Estimated Measurement Uncertainty.** The measurement uncertainties are estimated for each captured or fugitive emissions point as follows:  $Q_{Gj} = \pm 5.5$  percent and  $C_{Gj} = \pm 5$  percent. Based on these numbers, the probable uncertainty for  $G$  is estimated at about  $\pm 7.4$  percent.

**1.4 Sampling Requirements.** A capture efficiency test shall consist of at least three sampling runs. The sampling time for each run should be at least 8 hours, unless otherwise approved.

**1.5 Notes.** Because this procedure is often applied in highly explosive areas, caution and care should be exercised in choosing appropriate equipment and installing and using the equipment. Mention of trade names or company products does not constitute endorsement. All gas concentrations (percent, ppm) are by volume, unless otherwise noted.

#### 2. APPARATUS AND REAGENTS

**2.1 Gas VOC Concentration.** A schematic of the measurement system is shown in Figure 1. The main components are described below:

**2.1.1 Dilution System.** A Kipp in-stack dilution probe and controller or similar device may be used. The dilution rate may be changed by substituting different critical orifices or adjustments of the aspirator supply pressure. The dilution system shall be heated to prevent VOC condensation. **Note:** An out-of-stack dilution device may be used.

**2.1.2 Calibration Valve Assembly.** Three-way valve assembly at the outlet of sample probe to



direct the zero and calibration gases to the analyzer. Other methods, such as quick-connect lines, to route calibration gases to the outlet of the sample probe are acceptable.

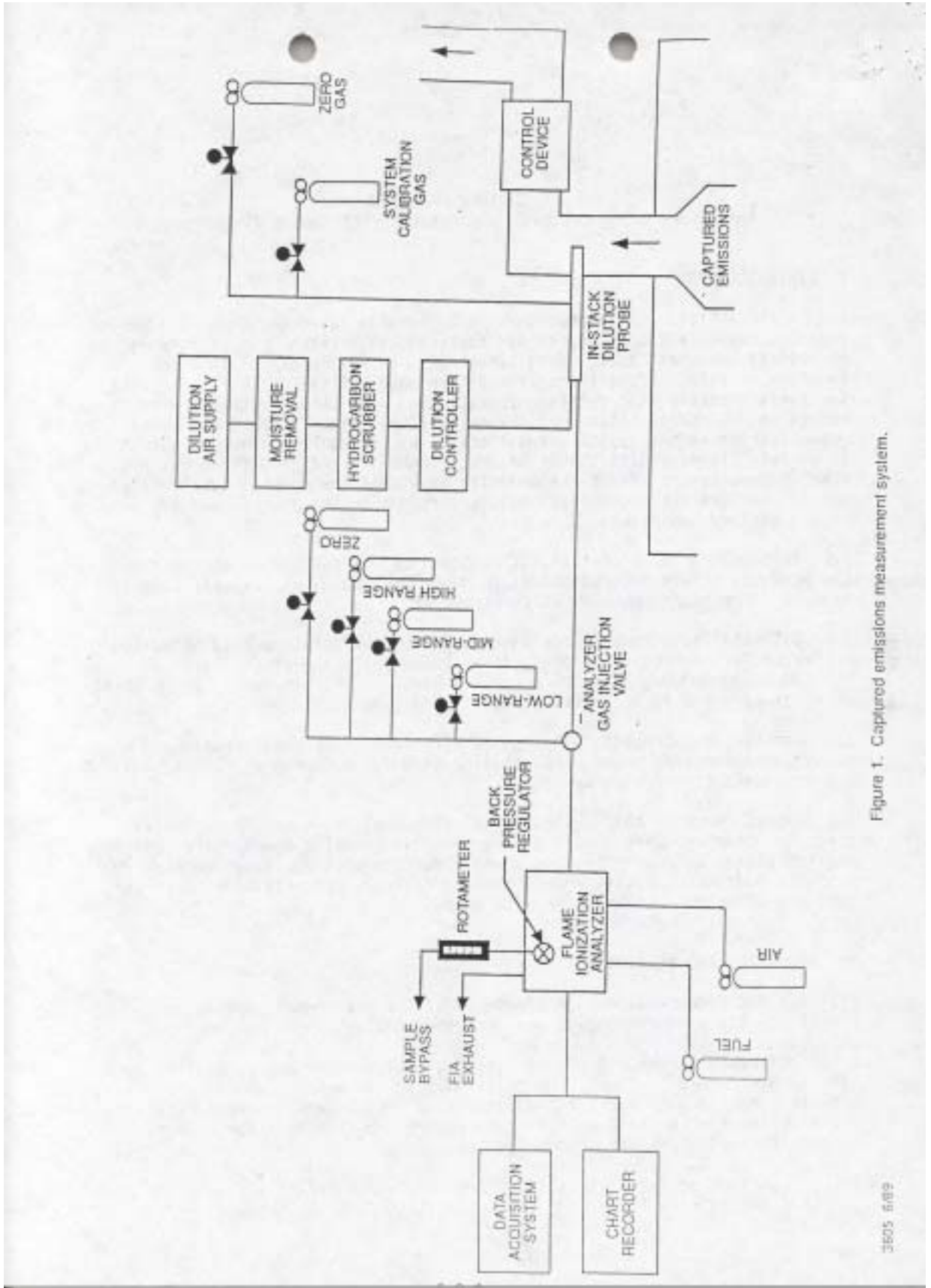

Figure 1. Captured emissions measurement system.

3605 6/89

**2.1.3 Sample Line.** Stainless steel or Teflon tubing to transport the sample gas to the analyzer. The sample line must be heated to prevent condensation.

**2.1.4 Sample Pump.** A leak-free pump, to pull the sample gas through the system at a flow rate sufficient to minimize the response time of the measurement system. The components of the pump that contact the gas stream shall be constructed of stainless steel or Teflon. The sample pump must be heated to prevent condensation.

**2.1.5 Sample Flow Rate Control.** A sample flow rate control valve and rotameter, or equivalent, to maintain a constant sampling rate within 10 percent. The flow control valve and rotameter must be heated to prevent condensation. A control valve may also be located on the sample pump bypass loop to assist in controlling the sample pressure and flow rate.

**2.1.6 Sample Gas Manifold.** Capable of diverting a portion of the sample gas stream to the flame ionization analyzer (FIA), and the remainder to the bypass discharge vent. The manifold components shall be constructed of stainless steel or Teflon. If captured or fugitive emissions are to be measured at multiple locations, the measurement system shall be designed to use separate sampling probes, lines, and pumps for each measurement location and a common sample gas manifold and FIA. The sample gas manifold and connecting lines to the FIA must be heated to prevent condensation.

**2.1.7 Organic Concentration Analyzer.** An FIA with a span value of 1.5 times the expected concentration as propane; however, other span values may be used if it can be demonstrated that they would provide more accurate measurements. The system shall be capable of meeting or exceeding the following specifications:

**2.1.7.1 Zero Drift.** Less than  $\pm 3.0$  percent of the span value.

**2.1.7.2 Calibration Drift.** Less than  $\pm 3.0$  percent of the span value.

**2.1.7.3 Calibration Error.** Less than  $\pm 5.0$  percent of the calibration gas value.

**2.1.7.4 Response Time.** Less than 30 seconds.

**2.1.8 Integrator/Data Acquisition System.** An analog or digital device or computerized data acquisition system used to integrate the FIA response or compute the average response and record measurement data. The minimum data sampling frequency for computing average or integrated values is one measurement value every 5 seconds. The device shall be capable of recording average values at least once per minute.

**2.1.9 Calibration and Other Gases.** Gases used for calibration, fuel, and combustion air (if required) are contained in compressed gas cylinders. All calibration gases shall be traceable to NIST standards and shall be certified by the manufacturer to  $\pm 1$  percent of the tag value. Additionally, the manufacturer of the cylinder should provide a recommended shelf life for each calibration gas cylinder over which the concentration does not change more than  $\pm 2$  percent

from the certified value. For calibration gas values not generally available, alternative methods for preparing calibration gas mixtures, such as dilution systems, may be used with prior approval.

**2.1.9.1 Fuel.** A 40 percent H<sub>2</sub>/60 percent He or 40 percent H<sub>2</sub>/60 percent N<sub>2</sub> gas mixture is recommended to avoid an oxygen synergism effect that reportedly occurs when oxygen concentration varies significantly from a mean value.

**2.1.9.2 Carrier Gas and Dilution Air Supply.** High purity air with less than 1 ppm of organic material (as propane or carbon equivalent) or less than 0.1 percent of the span value; whichever is greater.

**2.1.9.3 FIA Linearity Calibration Gases.** Low-, mid-, and high-range gas mixture standards with nominal propane concentrations of 20-30, 45-55, and 70-80 percent of the span value in air, respectively. Other calibration values and other span values may be used if it can be shown that more accurate measurements would be achieved.

**2.1.9.4 Dilution Check Gas.** Gas mixture standard containing propane in air, approximately half the span value after dilution.

**2.1.10 Particulate Filter.** An in-stack or an out-of-stack glass fiber filter is recommended if exhaust gas particulate loading is significant. An out-of-stack filter must be heated to prevent any condensation unless it can be demonstrated that no condensation occurs.

## **2.2 Captured Emissions Volumetric Flow Rate.**

**2.2.1 Method 2 or 2A Apparatus.** For determining volumetric flow rate.

**2.2.2 Method 3 Apparatus and Reagents.** For determining molecular weight of the gas stream. An estimate of the molecular weight of the gas stream may be used if it can be justified.

**2.2.3 Method 4 Apparatus and Reagents.** For determining moisture content, if necessary.

## **3. DETERMINATION OF VOLUMETRIC FLOW RATE OF CAPTURED EMISSIONS**

**3.1.1** Locate all points where emissions are captured from the affected facility. Using Method 1, determine the sampling points. Be sure to check each site for cyclonic or swirling flow.

**3.1.2** Measure the velocity at each sampling site at least once every hour during each sampling run using Method 2 or 2A.

## **4. DETERMINATION OF VOC CONTENT OF CAPTURED EMISSIONS**

**4.1 Analysis Duration.** Measure the VOC responses at each captured emissions point during

the entire test run or, if applicable, while the process is operating. If there are a multiple captured emissions locations, design a sampling system to allow a single FIA to be used to determine the VOC responses at all sampling locations.

## **4.2 Gas VOC Concentration.**

**4.2.1** Assemble the sample train as shown in Figure 1. Calibrate the FIA according to the procedure in Section 5.1.

**4.2.2** Set the dilution ratio and determine the dilution factor according to the procedure in Section 5.3.

**4.2.3** Conduct a system check according to the procedure in Section 5.4.

**4.2.4** Install the sample probe so that the probe is centrally located in the stack, pipe, or duct, and is sealed tightly at the stack port connection.

**4.2.5** Inject zero gas at the calibration valve assembly. Measure the system response time as the time required for the system to reach the effluent concentration after the calibration valve has been returned to the effluent sampling position.

**4.2.6** Conduct a system check before and a system drift check after each sampling run according to the procedures in Sections 5.2 and 5.4. If the drift check following a run indicates unacceptable performance, the run is not valid. The tester may elect to perform system drift checks during the run not to exceed one drift check per hour.

**4.2.7** Verify that the sample lines, filter, and pump temperatures are  $120 \pm 5^{\circ}\text{C}$ .

**4.2.8** Begin sampling at the start of the test period and continue to sample during the entire run. Record the starting and ending times and any required process information as appropriate. If multiple captured emission locations are sampled using a single FIA, sample at each location for the same amount of time (e.g., 2 minutes) and continue to switch from one location to another for the entire test run. Be sure that total sampling time at each location is the same at the end of the test run. Collect at least 4 separate measurements from each sample point during each hour of testing. Disregard the measurements at each sampling location until two times the response time of the measurement system has elapsed. Continue sampling for at least 1 minute and record the concentration measurements.

## **4.3 Background Concentration.**

**4.3.1** Locate all NDO's of the TTE. A sampling point shall be centrally located outside of the TTE at 4 equivalent diameters from each NDO, if possible. If there are more than 6 NDO's, choose 6 sampling points evenly spaced among the NDO's.

**4.3.2** Assemble the sample train as shown in Figure 2. Calibrate the FIA and conduct a system

check according to the procedures in Sections 5.1 and 5.4.

**4.3.3** Position the probe at the sampling location.

**4.3.4** Determine the response time, conduct the system check and sample according to the procedures described in Sections 4.2.4 to 4.2.8.

**4.4 Alternative Procedure.** The direct interface sampling and analysis procedure described in

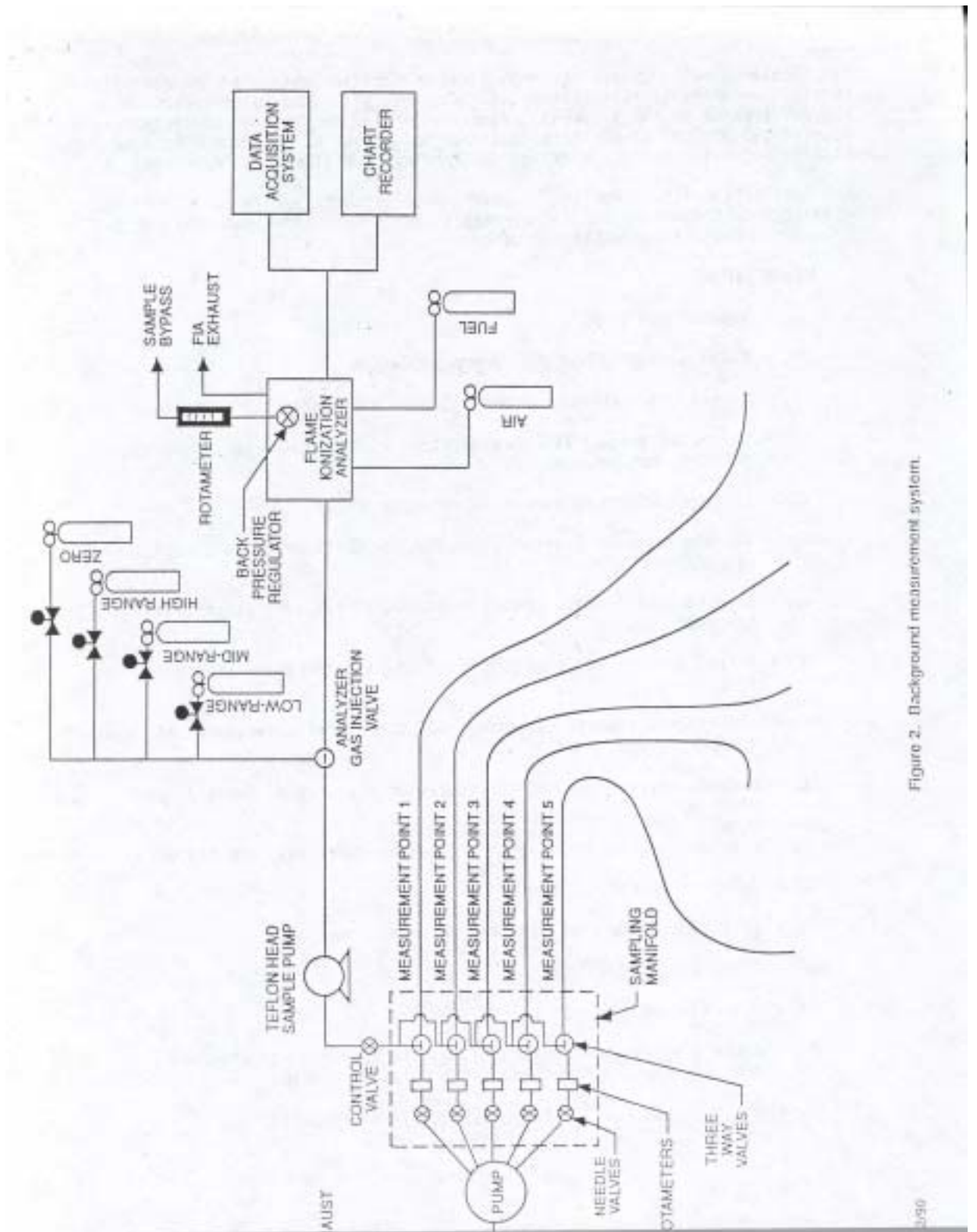

Figure 2. Background measurement system.

Section 7.2 of Method 18 may be used to determine the gas VOC concentration. The system must be designed to collect and analyze at least one sample every 10 minutes.

## 5. CALIBRATION AND QUALITY ASSURANCE

**5.1 FIA Calibration and Linearity Check.** Make necessary adjustments to the air and fuel supplies for the FIA and ignite the burner. Allow the FIA to warm up for the period recommended by the manufacturer. Inject a calibration gas into the measurement system after the dilution system and adjust the back-pressure regulator to the value required to achieve the flow rates specified by the manufacturer. Inject the zero- and the high-range calibration gases and adjust the analyzer calibration to provide the proper responses. Inject the low- and mid-range gases and record the responses of the measurement system. The calibration and linearity of the system are acceptable if the responses for all four gases are within 5 percent of the respective gas values. If the performance of the system is not acceptable, repair or adjust the system and repeat the linearity check. Conduct a calibration and linearity check after assembling the analysis system and after a major change is made to the system.

**5.2 Systems Drift Checks.** Select the calibration gas that most closely approximates the concentration of the diluted captured emissions for conducting the drift checks. Introduce the zero and calibration gas at the calibration valve assembly and verify that the appropriate gas flow rate and pressure are present at the FIA. Record the measurement system responses to the zero and calibration gases. The performance of the system is acceptable if the difference between the drift check measurement and the value obtained in Section 5.1 is less than 3 percent of the span value. Conduct the system drift check at the end of each run.

**5.3 Determination of Dilution Factor.** Inject the dilution check gas into the measurement system before the dilution system and record the response. Calculate the dilution factor using Equation 3.

**5.4 System Check.** Inject the high range calibration gas at the inlet to the sampling probe while the dilution air is turned off. Record the response. The performance of the system is acceptable if the measurement system response is within 5 percent of the value obtained in Section 5.1 for the high range calibration gas. Conduct a system check before and after each test run.

**5.5 Analysis Audit.** Immediately before each test analyze an audit cylinder as described in Section 5.2. The analysis audit must agree with the audit cylinder concentration within 10 percent.

## 6. NOMENCLATURE

$A_i$  = area of NDO  $i$ , ft<sup>2</sup>.

$A_H$  = total area of all NDO's in the enclosure, ft<sup>2</sup>.



$C_A$  = actual concentration of the dilution check gas, ppm propane.

$C_{Bi}$  = corrected average VOC concentration of background emissions at point i, ppm propane.

$C_B$  = average background concentration, ppm propane.

$C_{DH}$  = average measured concentration for the drift check calibration gas, ppm propane.

$C_{DO}$  = average system drift check concentration for zero concentration gas, ppm propane.

$C_H$  = actual concentration of the drift check calibration gas, ppm propane.

$C_i$  = uncorrected average background VOC concentration measured at point i, ppm propane.

$C_j$  = uncorrected average VOC concentration measured at point j, ppm propane.

$C_M$  = measured concentration of the dilution check gas, ppm propane.

DF = dilution factor.

G = total VOC content of captured emissions, kg.

$K_1 = 1.830 \times 10^{-6} \text{ kg}/(\text{m}^3\text{-ppm})$ .

n = number of measurement points.

$Q_{Gj}$  = average effluent volumetric flow rate corrected to standard conditions at captured emissions point j,  $\text{m}^3/\text{min}$ .

$c$  = total duration of capture efficiency sampling run, min.

## 7. CALCULATIONS

### 7.1 Total VOC Captured Emissions.

$$G = \sum_{j=1}^n C_{Gj} Q_{Gj} c K_1 \quad \text{Eq. 1}$$

### 7.2 VOC Concentration of the Captured Emissions at Point j.

$$C_{Gj} = DF (C_j - C_{DO}) \frac{H}{DH - C_{DO}} C \quad \text{Eq. 2}$$

### 7.3 Dilution Factor

$$DF = \frac{A C}{M C} \quad \text{Eq. 3}$$

### 7.4 Background VOC Concentration at Point i.

$$C_{Bi} = (C_i - C_{DO}) \frac{H}{DH - C_{DO}} C \quad \text{Eq. 4}$$

### 7.5 Average Background Concentration.

$$C_B = \frac{\sum_{i=1}^n C_{Bi} A_i}{n_H A} \quad \text{Eq. 5}$$

**NOTE:** If the concentration at each point is within 20 percent of the average concentration of all points, the terms "A<sub>i</sub>" and "A<sub>H</sub>" may be deleted from Equation 4.

# VOC CAPTURE EFFICIENCY

## Procedure L - VOC Input

### 1. INTRODUCTION

**1.1 Applicability.** This procedure is applicable for determining the input of volatile organic compounds (VOC). It is intended to be used as a segment in the development of liquid/gas protocols for determining VOC capture efficiency (CE) for surface coating and printing operations.

**1.2 Principle.** The amount of VOC introduced to the process (L) is the sum of the products of the weight (W) of each VOC containing liquid (ink, paint, solvent, etc.) used and its VOC content (V). A sample of each VOC containing liquid is analyzed with a flame ionization analyzer (FIA) to determine V.

**1.3 Estimated Measurement Uncertainty.** The measurement uncertainties are estimated for each VOC containing liquid as follows:  $W = \pm 2.0$  percent and  $V = \pm 12.0$  percent. Based on these numbers, the probable uncertainty for L is estimated at about  $\pm 12.2$  percent for each VOC containing liquid.

**1.4 Sampling Requirements.** A capture efficiency test shall consist of at least three sampling runs. The sampling time for each run should be at least 8 hours, unless otherwise approved.

**1.5 Notes.** Because this procedure is often applied in highly explosive areas, caution and care should be exercised in choosing appropriate equipment and installing and using the equipment. Mention of trade names or company products does not constitute endorsement. All gas concentrations (percent, ppm) are by volume, unless otherwise noted.

### 2. APPARATUS AND REAGENTS

#### 2.1 Liquid Weight.

**2.1.1 Balances/Digital Scales.** To weigh drums of VOC containing liquids to within 0.2 lb.

**2.1.2 Volume Measurement Apparatus (Alternative).** Volume meters, flow meters, density measurement equipment, etc., as needed to achieve same accuracy as direct weight measurements.

**2.2 VOC Content (Flame Ionization Analyzer Technique).** The liquid sample analysis system is shown in Figures 1 and 2. The following equipment is required:

**2.2.1 Sample Collection Can.** An appropriately sized metal can to be used to collect VOC

containing materials. The can must be constructed in such a way that it can be grounded to the coating container.

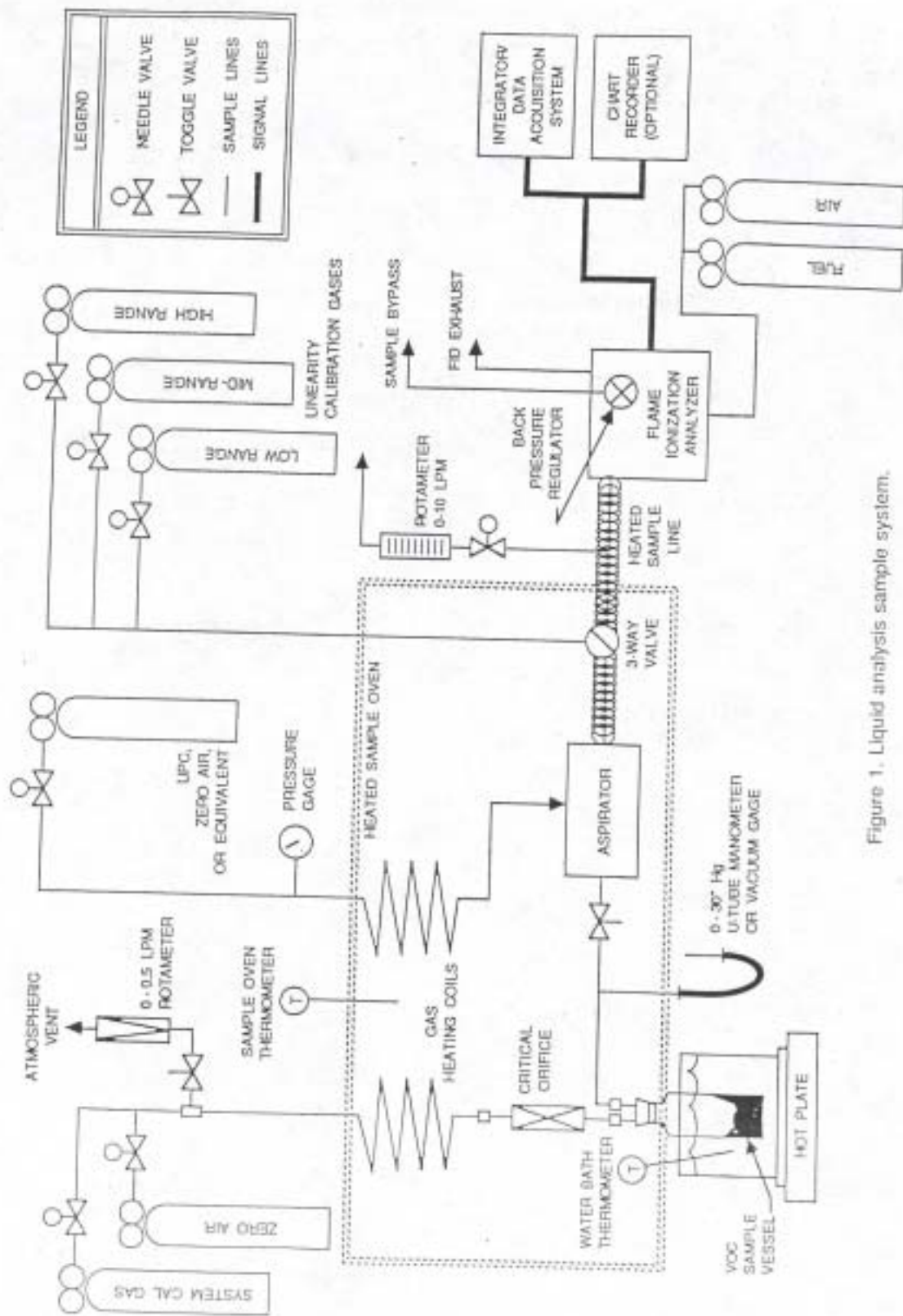

Figure 1. Liquid analysis sample system.

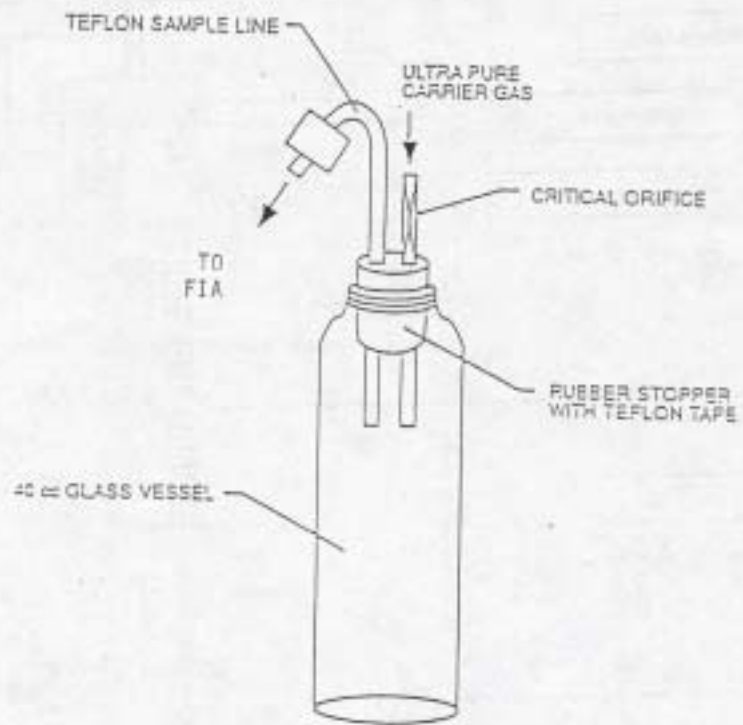

Figure 2. VOC sampling vessel.

L-3

**2.2.2. Needle Valves.** To control gas flow.

**2.2.2 Needle Valves.** To control gas flow.

**2.2.3 Regulators.** For carrier gas and calibration gas cylinders.

**2.2.4 Tubing.** Teflon or stainless steel tubing with diameters and lengths determined by connection requirements of equipment. The tubing between the sample oven outlet and the FIA shall be heated to maintain a temperature of  $120 \pm 5^{\circ}\text{C}$ .

**2.2.5 Atmospheric Vent.** A tee and 0- to 0.5- liter/min rotameter placed in the sampling line between the carrier gas cylinder and the VOC sample vessel to release the excess carrier gas. A toggle valve placed between the tee and the rotameter facilitates leak tests of the analysis system.

**2.2.6 Thermometer.** Capable of measuring the temperature of the hot water bath to within  $1^{\circ}\text{C}$ .

**2.2.7 Sample oven.** Heated enclosure, containing calibration gas coil heaters, critical orifice, aspirator, and other liquid sample analysis components, capable of maintaining a temperature of  $120 \pm 5^{\circ}\text{C}$ .

**2.2.8 Gas Coil Heaters.** Sufficient lengths of stainless steel or Teflon tubing to allow zero and calibration gases to be heated to the sample oven temperature before entering the critical orifice or aspirator.

**2.2.9 Water Bath.** Capable of heating and maintaining a sample vessel temperature of  $100 \pm 5^{\circ}\text{C}$ .

**2.2.10 Analytical Balance.** To measure to  $\pm 0.001$  g.

**2.2.11 Disposable Syringes.** 2-cc or 5-cc.

**2.2.12 Sample Vessel.** Glass, 40-ml septum vial. A separate vessel is needed for each sample.

**2.2.13 Rubber Stopper.** Two-hole stopper to accommodate 3.2-mm (1/8-in.) Teflon tubing, appropriately sized to fit the opening of the sample vessel. The rubber stopper should be wrapped in Teflon tape to provide a tighter seal and to prevent any reaction of the sample with the rubber stopper. Alternatively, any leak-free closure fabricated of non-reactive materials and accommodating the necessary tubing fittings may be used.

**2.2.14 Critical Orifices.** Calibrated critical orifices capable of providing constant flow rates from 50 to 250 ml/min at known pressure drops. Sapphire orifice assemblies (available from O'Keefe Controls Company) and glass capillary tubing have been found to be adequate for this application.

**2.2.15 Vacuum Gauge.** 0- to 760-mm (0- to 30-in.) Hg U-Tube manometer or vacuum gauge.

**2.2.16 Pressure Gauge.** Bourdon gauge capable of measuring the maximum air pressure at the aspirator inlet (e.g., 100 psig).

**2.2.17 Aspirator.** A device capable of generating sufficient vacuum at the sample vessel to create critical flow through the calibrated orifice when sufficient air pressure is present at the aspirator inlet. The aspirator must also provide sufficient sample pressure to operate the FIA. The sample is also mixed with the dilution gas within the aspirator.

**2.2.18 Soap Bubble Meter.** Of an appropriate size to calibrate the critical orifices in the system.

**2.2.19 Organic Concentration Analyzer.** An FIA with a span value of 1.5 times the expected concentration as propane; however other span values may be used if it can be demonstrated that they would provide more accurate measurements. The system shall be capable of meeting or exceeding the following specifications:

**2.2.19.1 Zero Drift.** Less than  $\pm 3.0$  percent of the span value.

**2.2.19.2 Calibration Drift.** Less than  $\pm 3.0$  percent of span value.

**2.2.19.3 Calibration Error.** Less than  $\pm 5.0$  percent of the calibration gas value.

**2.2.20 Integrator/Data Acquisition System.** An analog or digital device or computerized data acquisition system used to integrate the FIA response or compute the average response and record measurement data. The minimum data sampling frequency for computing average or integrated values is one measurement value every 5 seconds. The device shall be capable of recording average values at least once per minute.

**2.2.21 Chart Recorder (Optional).** A chart recorder or similar device is recommended to provide a continuous analog display of the measurement results during the liquid sample analysis.

**2.2.22 Calibration and other Gases.** For calibration, fuel, and combustion air (if required) contained in compressed gas cylinders. All calibration gases shall be traceable to NIST standards and shall be certified by the manufacturer to  $\pm 1$  percent of the tag value. Additionally, the manufacturer the cylinder should provide a recommended shelf life for each calibration gas cylinder over which the concentration does not change more than  $\pm 2$  percent from the certified value. For calibration gas values not generally available, alternative methods for preparing calibration gas mixtures, such as dilution systems, may be used with prior approval.

**2.2.22.1 Fuel.** A 40 percent  $H_2$ /60 percent He or 40 percent  $H_2$ /60 percent  $N_2$  gas mixture is recommended to avoid an oxygen synergism effect that reportedly occurs when oxygen concentration varies significantly from a mean value.

**2.2.22.2 Carrier Gas.** High purity air with less than 1 ppm of organic material (as propane) or



less than 0.1 percent of the span value, whichever is greater.

**2.2.22.3 FIA linearity Calibration Gases.** Low-, mid-, and high-range gas mixture standards with nominal propane concentrations of 20-30, 45-55, and 70-80 percent of the span value in air, respectively. Other calibration values and other span values may be used if it can be shown that more accurate measurements would be achieved.

**2.2.22.4 System Calibration Gas.** Gas mixture standard containing propane in air, approximating the undiluted VOC concentration expected for the liquid samples.

### **3. DETERMINATION OF LIQUID INPUT WEIGHT**

**3.1 Weight Difference.** Determine the amount of material introduced to the process as the weight difference of the feed material before and after each sampling run. In determining the total VOC containing liquid usage, account for: (a) the initial (beginning)VOC containing liquid mixture; (b) any solvent added during the test run; (c) any coating added during the test run; and (d) any residual VOC containing liquid mixture remaining at the end of the sample run.

**3.1.1** Identify all points where VOC containing liquids are introduced to the process. To obtain an accurate measurement of VOC containing liquids, start with an empty fountain (if applicable). After completing the run, drain the liquid in the fountain back into the liquid drum (if possible), and weigh the drum again. Weigh the VOC containing liquids to  $\pm 0.5$  percent of the total weight (full) or  $\pm 0.1$  percent of the total weight of VOC containing liquid used during the sample run, whichever is less. If the residual liquid cannot be returned to the drum, drain the fountain into a preweighed empty drum to determine the final weight of the liquid.

**3.1.2** If it is not possible to measure a single representative mixture, then weigh the various components separately (e.g., if solvent is added during the sampling run, weigh the solvent before it is added to the mixture). If a fresh drum of VOC containing liquid is needed during the run, then weigh both the empty drum and fresh drum.

**3.2 Volume Measurement (Alternative).** If direct weight measurements are not feasible, the tester may use volume meters and flow rate meters (and density measurements) to determine the weight of liquids used if it can be demonstrated that the technique produces results equivalent to the direct weight measurements. If a single representative mixture cannot be measured, measure the components separately.

### **4. DETERMINATION OF VOC CONTENT IN INPUT LIQUIDS**

#### **4.1 Collection of liquid Samples.**

**4.1.1** Collect a 100-ml or larger sample of the VOC containing liquid mixture at each application location at the beginning and end of each test run. A separate sample should be taken of each

VOC containing liquid added to the application mixture during the test run. If a fresh drum is needed during the sampling run, then obtain a sample from the fresh drum.

**4.1.2** When collecting the sample, ground the sample container to the coating drum. Fill the sample container as close to the rim as possible to minimize the amount of headspace.

**4.1.3** After the sample is collected, seal the container so the sample cannot leak out or evaporate.

**4.1.4** Label the container to identify clearly the contents.

## **4.2 Liquid Sample VOC Content.**

**4.2.1** Assemble the liquid VOC content analysis system as shown in Figure 1.

**4.2.2** Permanently identify all of the critical orifices that may be used. Calibrate each critical orifice under the expected operating conditions (i.e., sample vacuum and temperature) against a volume meter as described in Section 5.3.

**4.2.3** Label and tare the sample vessels (including the stoppers and caps) and the syringes.

**4.2.4** Install an empty sample vessel and perform a leak test of the system. Close the carrier gas valve and atmospheric vent and evacuate the sample vessel to 250 mm (10 in.) Hg absolute or less using the aspirator. Close the toggle valve at the inlet to the aspirator and observe the vacuum for at least one minute. If there is any change in the sample pressure, release the vacuum, adjust or repair the apparatus as necessary and repeat the leak test.

**4.2.5** Perform the analyzer calibration and linearity checks according to the procedure in Section 5.1. Record the responses to each of the calibration gases and the back-pressure setting of the FIA.

**4.2.6** Establish the appropriate dilution ratio by adjusting the aspirator air supply or substituting critical orifices. Operate the aspirator at a vacuum of at least 25 mm (1 in.) Hg greater than the vacuum necessary to achieve critical flow. Select the dilution ratio so that the maximum response of the FIA to the sample does not exceed the high-range calibration gas.

**4.2.7** Perform system calibration checks at two levels by introducing compressed gases at the inlet to the sample vessel while the aspirator and dilution devices are operating. Perform these checks using the carrier gas (zero concentration) and the system calibration gas. If the response to the carrier gas exceeds  $\pm 0.5$  percent of span, clean or repair the apparatus and repeat the check. Adjust the dilution ratio as necessary to achieve the correct response to the upscale check, but do not adjust the analyzer calibration. Record the identification of the orifice, aspirator air supply pressure, FIA back-pressure, and the responses of the FIA to the carrier and system calibration gases.

**4.2.8** After completing the above checks, inject the system calibration gas for approximately 10

minutes. Time the exact duration of the gas injection using a stopwatch. Determine the area under the FIA response curve and calculate the system response factor based on the sample gas flow rate, gas concentration, and the duration of the injection as compared to the integrated response using Equations 2 and 3.

**4.2.9** Verify that the sample oven and sample line temperatures are  $120 \pm 5^\circ\text{C}$  and that the water bath temperature is  $100^\circ \pm 5^\circ\text{C}$ .

**4.2.10** Fill a tared syringe with approximately 1 g of the VOC containing liquid and weigh it. Transfer the liquid to a tared sample vessel. Plug the sample vessel to minimize sample loss. Weigh the sample vessel containing the liquid to determine the amount of sample actually received. Also, as a quality control check, weigh the empty syringe to determine the amount of material delivered. The two coating sample weights should agree within  $\pm 0.02$  g. If not, repeat the procedure until an acceptable sample is obtained.

**4.2.11** Connect the vessel to the analysis system. Adjust the aspirator supply pressure to the correct value. Open the valve on the carrier gas supply to the sample vessel and adjust it to provide a slight excess flow to the atmospheric vent. As soon as the initial response of the FIA begins to decrease, immerse the sample vessel in the water bath. (Applying heat to the sample vessel too soon may cause the FID response to exceed the calibrated range of the instrument, and thus invalidate the analysis.)

**4.2.12** Continuously measure and record the response of the FIA until all of the volatile material has been evaporated from the sample and the instrument response has returned to the baseline (i.e., response less than 0.5 percent of the span value). Observe the aspirator supply pressure, FIA back-pressure, atmospheric vent, and other system operating parameters during the run; repeat the analysis procedure if any of these parameters deviate from the values established during the system calibration checks in Section 4.2.7. After each sample perform the drift check described in Section 5.2. If the drift check results are acceptable, calculate the VOC content of the sample using the equations in Section 7. Integrate the area under the FIA response curve, or determine the average concentration response and the duration of sample analysis.

## **5. CALIBRATION AND QUALITY ASSURANCE**

**5.1 FIA Calibration and Linearity Check.** Make necessary adjustments to the air and fuel supplies for the FIA and ignite the burner. Allow the FIA to warm up for the period recommended by the manufacturer. Inject a calibration gas into the measurement system and adjust the back-pressure regulator to the value required to achieve the flow rates specified by the manufacturer. Inject the zero- and the high-range calibration gases and adjust the analyzer calibration to provide the proper responses. Inject the low- and mid-range gases and record the responses of the measurement system. The calibration and linearity of the system are acceptable if the responses for all four gases are within 5 percent of the respective gas values. If the performance of the system is not acceptable, repair or adjust the system and repeat the linearity check. Conduct a calibration and linearity check after assembling the analysis system and after a

major change is made to the system.

**5.2 Systems Drift Checks.** After each sample, repeat the system calibration checks in Section 4.2.7 before any adjustments to the FIA or measurement system are made. If the zero or calibration drift exceeds  $\pm 3$  percent of the span value, discard the result and repeat the analysis.

### **5.3 Critical Orifice Calibration.**

**5.3.1** Each critical orifice must be calibrated at the specific operating conditions that it will be used. Therefore, assemble all components of the liquid sample analysis system as shown in Figure 3. A stopwatch is also required.

**5.3.2** Turn on the sample oven, sample line, and water bath heaters and allow the system to reach the proper operating temperature. Adjust the aspirator to a vacuum of 380 mm (15 in.) Hg vacuum. Measure the time required for one soap bubble to move a known distance and record barometric pressure.

**5.3.3** Repeat the calibration procedure at a vacuum of 406 mm (16 in.) Hg and at 25-mm (1-in.) Hg intervals until three consecutive determinations provide the same flow rate. Calculate the critical flow rate for the orifice in ml/min at standard conditions. Record the vacuum necessary to achieve critical flow.

## **6. NOMENCLATURE**

$A_L$  = area under the response curve of the liquid sample, area count.

$A_S$  = area under the response curve of the calibration gas, area count.

$C_S$  = actual concentration of system calibration gas, ppm propane.

$K$  =  $1.830 \times 10^{-9}$  g/(ml-ppm).

$L$  = total VOC content of liquid input, kg.

$M_L$  = mass of liquid sample delivered to the sample vessel, g.

$q$  = flow rate through critical orifice, ml/min.

$RF$  = liquid analysis system response factor, g/area count.

$t_s$  = total gas injection time for system calibration gas during integrator calibration, min.

$V_{Fj}$  = final VOC fraction of VOC containing liquid j.

$V_{ij}$  = initial VOC fraction of VOC containing liquid j.

$V_{Aj}$  = VOC fraction of VOC containing liquid j added during the run.

$V$  = VOC fraction of liquid sample.

$W_{Fj}$  = weight of VOC containing liquid j remaining at end of the run, kg.

$W_{ij}$  = weight of VOC containing liquid j at beginning of the run, kg.

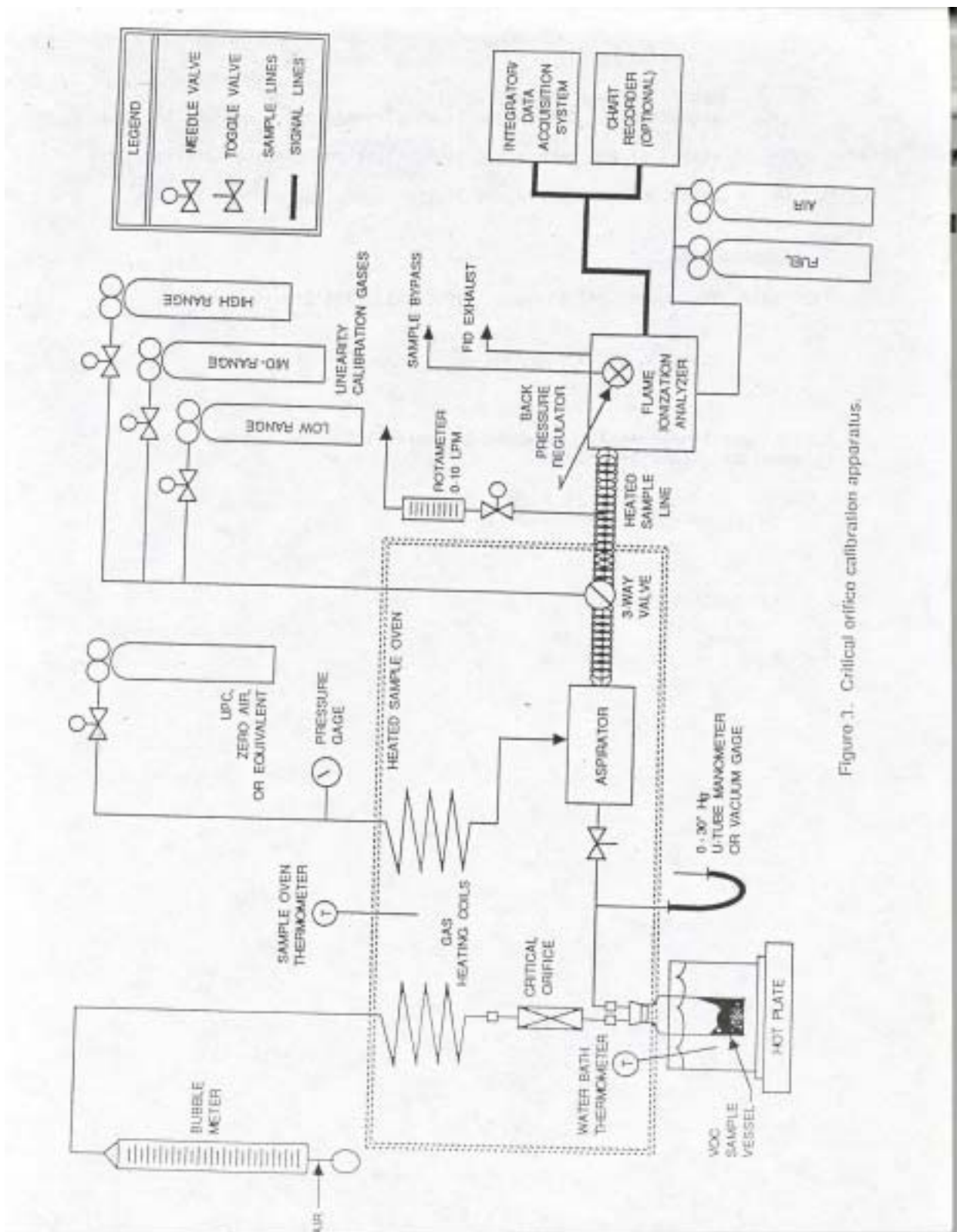

Figure 3. Critical orifice calibration apparatus.



$W_{Aj}$  = weight of VOC containing liquid j added during the run, kg.

## 7. CALCULATIONS

### 7.1 Total VOC Content of the Input VOC Containing Liquid.

$$L = \sum_{j=1}^n V_{lj} W_{lj} - \sum_{j=1}^n V_{Fj} W_{Fj} + \sum_{j=1}^n V_{Aj} W_{Aj} \quad \text{Eq. 1}$$

### 7.2 Liquid Sample Analysis System Response Factor for Systems Using Integrators, Grams/Area Counts.

$$RF = \frac{C_s K}{A_s} \quad \text{Eq. 2}$$

### 7.3 VOC Content of the Liquid Sample,

$$V = \frac{L RF}{M} \quad \text{Eq. 3}$$



## VOC CAPTURE EFFICIENCY

### Procedure T - Criteria for and Verification of a Permanent or Temporary Total Enclosure

#### 1. INTRODUCTION

**1.1 Applicability.** This procedure is used to determine whether a permanent or temporary enclosure meets the criteria of a total enclosure.

**1.2 Principle.** An enclosure is evaluated against a set of criteria. If the criteria are met and if all the exhaust gases are ducted to a control device, then the volatile organic compounds (VOC) capture efficiency (CE) is assumed to be 100 percent and CE need not be measured. However, if part of the exhaust gas stream is not ducted to a control device, CE must be determined.

#### 2. DEFINITIONS

**2.1 Natural Draft Opening (NDO)** Any permanent opening in the enclosure that remains open during operation of the facility and is not connected to a duct in which a fan is installed.

**2.2 Permanent Total Enclosure (PTE)** A permanently installed enclosure that completely surrounds a source of emissions such that all VOC emissions are captured and contained for discharge through a control device.

**2.3 Temporary Total Enclosure (TTE)** A temporarily installed enclosure that completely surrounds a source of emissions such that all VOC emissions are captured and contained for discharge through ducts that allow for the accurate measurement of VOC rates.

#### 3. CRITERIA OF A TEMPORARY TOTAL ENCLOSURE

**3.1** Any NDO shall be at least 4 equivalent opening diameters from each VOC emitting point.

**3.2** Any exhaust point from the enclosure shall be at least 4 equivalent duct or hood diameters from each NDO.

**3.3** The total area of all NDO's shall not exceed 5 percent of the surface area of the enclosure's four walls, floor, and ceiling.

**3.4** The average facial velocity (FV) of air through all NDO's shall be at least 3,600 m/hr (200 fpm). The direction of air through all NDO's shall be into the enclosure.

**3.5** All access doors and windows whose areas are not included in Section 3.3 and are not

included in the calculation in Section 3.4 shall be closed during routine operation of the process.

#### 4. CRITERIA OF A PERMANENT TOTAL ENCLOSURE

4.1 Same as Sections 3.1 and 3.3 - 3.5.

4.2 All VOC emissions must be captured and contained for discharge through a control device.

#### 5. PROCEDURE

5.1 Determine the equivalent diameters of the NDO's and determine the distances from each VOC emitting point to all NDO's. Determine the equivalent diameter of each exhaust duct or hood and its distance to all NDO's. Calculate the distances in terms of equivalent diameters. The number of equivalent diameters shall be at least 4.

5.2 Measure the total area ( $A_t$ ) of the enclosure and the total area ( $A_H$ ) of all NDO's of the enclosure. Calculate the NDO to enclosure area ratio (NEAR) as follows:

$$\text{NEAR} = A_H/A_t$$

The NEAR must be  $\geq 0.05$ .

5.3 Measure the volumetric flow rate, corrected to standard conditions, of each gas stream exiting the enclosure through an exhaust duct or hood using EPA Method 2. In some cases (e.g., when the building is the enclosure), it may be necessary to measure the volumetric flow rate, corrected to standard conditions, of each gas stream entering the enclosure through a forced makeup air duct using Method 2. Calculate FV using the following equation:

$$\text{FV} = [Q_o - Q_i] / A_H$$

where:

$Q_o$  = the sum of the volumetric flow from all gas streams exiting the enclosure through an exhaust duct or hood.

$Q_i$  = the sum of the volumetric flow from all gas streams into the enclosure through a forced makeup air duct; zero, if there is no forced makeup air into the enclosure.

$A_H$  = total area of all NDO's in enclosure.

The FV shall be at least 3,600 m/hr (200 fpm).

5.4 Verify that the direction of air flow through all NDO's is inward. Use streamers, smoke tubes, tracer gases, etc. Strips of plastic wrapping film have been found to be effective. Monitor

the direction of air flow at intervals of at least 10 minutes for at least 1 hour.

## **6. QUALITY ASSURANCE**

**6.1** The success of this protocol lies in designing the TTE to simulate the conditions that exist without the TTE, i.e., the effect of the TTE on the normal flow patterns around the affected facility or the amount of fugitive VOC emissions should be minimal. The TTE must enclose the application stations, coating reservoirs, and all areas from the application station to the oven. The oven does not have to be enclosed if it is under negative pressure. The NDO's of the temporary enclosure and a fugitive exhaust fan must be properly sized and placed.

**6.2.** Estimate the ventilation rate of the TTE that best simulates the conditions that exist without the TTE, i.e., the effect of the TTE on the normal flow patterns around the affected facility or the amount of fugitive VOC emissions should be minimal. Figure 1 may be used as an aid. Measure the concentration ( $C_G$ ) and flow rate ( $Q_G$ ) of the captured gas stream, specify a safe concentration ( $C_F$ ) for the fugitive gas stream; estimate the CE, and then use the plot in Figure 1 to determine the volumetric flowrate of the fugitive gas stream ( $Q_F$ ). A fugitive VOC emission exhaust fan that has a variable flow control is desirable.

**6.2.1** Monitor the concentration of VOC into the capture device without the TTE. To minimize the effect of temporal variation on the captured emissions, the baseline measurement should be made over as long a time period as practical. However, the process conditions must be the same for the measurement in Section 6.2.3 as they are for this baseline measurement. This may require short measuring times for this quality control check before and after the construction of the TTE .

**6.2.2** After the TTE is constructed, monitor the VOC concentration inside the TTE. This concentration shall not continue to increase and must not exceed the safe level according to OSHA requirements for permissible exposure limits. An increase in VOC concentration indicates poor TTE design or poor capture efficiency.

**6.2.3** Monitor the concentration of VOC into the capture device with the TTE. To limit the effect of the TTE on the process, the VOC concentration with and without the TTE must be within  $\pm 10$  percent. If the measurements do not agree, adjust the ventilation rate from the TTE until they agree within 10 percent.

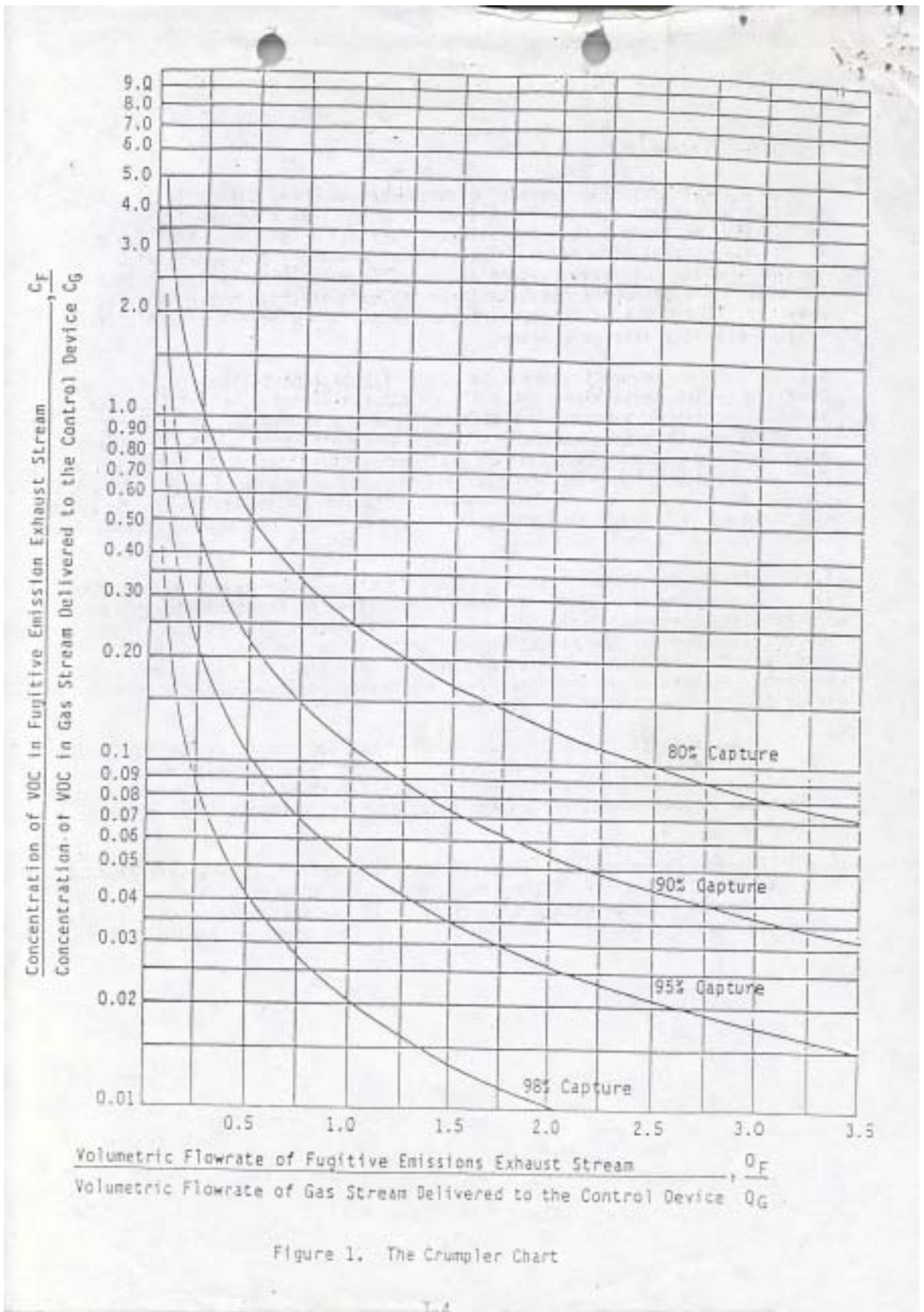

Figure 1. The Crumpler Chart

