

**Compendium of Methods
for the Determination of
Inorganic Compounds
in Ambient Air**

Compendium Method IO-3.6

**DETERMINATION OF METALS
IN AMBIENT PARTICULATE MATTER
USING PROTON INDUCED X-RAY
EMISSION (PIXE) SPECTROSCOPY**

Center for Environmental Research Information
Office of Research and Development
U.S. Environmental Protection Agency
Cincinnati, OH 45268

June 1999

Method IO-3.6

Acknowledgments

This Method is a part of *Compendium of Methods for the Determination of Inorganic Compounds in Ambient Air* (EPA/625/R-96/010a), which was prepared under Contract No. 68-C3-0315, WA No. 2-10, by Midwest Research Institute (MRI), as a subcontractor to Eastern Research Group, Inc. (ERG), and under the sponsorship of the U.S. Environmental Protection Agency (EPA). Justice A. Manning, John O. Burckle, Scott Hedges, Center for Environmental Research Information (CERI), and Frank F. McElroy, National Exposure Research Laboratory (NERL), all in the EPA Office of Research and Development, were responsible for overseeing the preparation of this method. Other support was provided by the following members of the Compendia Workgroup:

- James L. Cheney, U.S. Army Corps of Engineers, Omaha, NE
- Michael F. Davis, U.S. EPA, Region 7, KC, KS
- Joseph B. Elkins Jr., U.S. EPA, OAQPS, RTP, NC
- Robert G. Lewis, U.S. EPA, NERL, RTP, NC
- Justice A. Manning, U.S. EPA, ORD, Cincinnati, OH
- William A. McClenny, U.S. EPA, NERL, RTP, NC
- Frank F. McElroy, U.S. EPA, NERL, RTP, NC
- William T. "Jerry" Winberry, Jr., EnviroTech Solutions, Cary, NC

This Method is the result of the efforts of many individuals. Gratitude goes to each person involved in the preparation and review of this methodology.

Author(s)

- J. William Nelson, Florida State University, Tallahassee, FL
- Thomas Lapp, Midwest Research Institute, Cary, NC

Peer Reviewers

- David Brant, National Research Center for Coal and Energy, Morgantown, WV
- John Glass, SC Department of Health and Environmental Control, Columbia, SC
- David Harlos, Environmental Science and Engineering, Gainesville, FL
- Lauren Drees, U.S. EPA, NRMRI, Cincinnati, OH

DISCLAIMER

This Compendium has been subjected to the Agency's peer and administrative review, and it has been approved for publication as an EPA document. Mention of trade names or commercial products does not constitute endorsement or recommendation for use.

Method IO-3.6
Determination of Metals in Ambient Particulate Matter
Using Proton Induced X-Ray Emission (PIXE)
Spectroscopy

TABLE OF CONTENTS

	<u>Page</u>
1. Scope	3.6-1
2. Applicable Documents	3.6-2
2.1 ASTM Standards	3.6-2
2.2 Other Documents	3.6-2
3. Summary Of Method	3.6-2
3.1 Transport of Ambient Air Particulate Filters and Impaction Surfaces.	3.6-2
3.2 Multi-Element PIXE Analysis	3.6-2
4. Significance	3.6-3
5. Definitions	3.6-3
6. Descriptions of Air Sampling and Analytical Systems	3.6-4
6.1 Air Particulate Samples	3.6-4
6.2 Air Sampling Media (filters and impaction surfaces)	3.6-4
6.3 Air Particulate Samplers	3.6-4
6.4 Description of PIXE Analysis System	3.6-5
6.5 Laboratories with PIXE Capability	3.6-7
7. X-ray Spectra	3.6-7
7.1 X-ray Production	3.6-7
7.2 Computing Methods for Spectral Analysis	3.6-7
7.3 Elemental Mass Per Unit Area	3.6-7
7.4 Atmospheric Aerosol Concentrations	3.6-8
7.5 Detection Limits	3.6-8
8. Quality Control and Assurance	3.6-9
9. Precision and Accuracy	3.6-9
9.1 Precision	3.6-9
9.2 Accuracy	3.6-9
10. References	3.6-10

[This page intentionally left blank]

Chapter IO-3
CHEMICAL SPECIES ANALYSIS
OF FILTER COLLECTED SPM

Method IO-3.6
DETERMINATION OF METALS IN AMBIENT PARTICULATE MATTER
USING PROTON INDUCED X-RAY EMISSION (PIXE)
SPECTROSCOPY

1. Scope

1.1 Suspended particulate matter (SPM) in air generally is a complex multi-phase system consisting of all airborne solid and low vapor pressure liquified particles having aerodynamic particle sizes from below 0.01-100 μm and larger. Historically, SPM measurement has concentrated on total suspended particulates (TSP), with no preference to size selection.

1.2 Research on the health effects of TSP in ambient air has focused increasingly on particles that can be inhaled into the respiratory system, (i.e., particles of aerodynamic diameters less than 10 μm). The health community generally recognizes that these particles may cause significant, adverse health effects. Recent studies involving particle transport and transformation suggests strongly that atmospheric particles commonly occur in two distinct modes. The fine (< 2.5 μm) mode and the coarse (2.5 to 10.0 μm) mode. The fine or accumulation mode (also termed the respirable particulate matter) is attributed to growth of particles from the gas phase and subsequent agglomeration, while the coarse mode is made of mechanically abraded or ground particles. Particles that have grown from the gas phase tend to grow rapidly to accumulation mode particles around 0.5 μm , which are relatively stable in the air. This range of particle sizes includes inorganic ions such as sulfate, nitrate, ammonia, combustion-form carbon, organic aerosols, metals, and other combustion products. Coarse particles, on the other hand, are mainly produced by mechanical forces such as crushing and abrasion. Coarse particles, therefore, normally consist of finely divided minerals such as oxides of aluminum, silicon, iron, calcium, and potassium. Coarse particles of soil or dust primarily result from entrainment by the motion of air or from other mechanical action within their area. The suspended particulate matter of urban atmospheres contains substantial quantities of trace metals sulfates, organic matter, and other non-metallic constituents.

1.3 The procedure for analyzing the elemental metal components in ambient air particulate matter is described in this Compendium method. The method is based upon active sampling using particulate matter samplers which collect ambient air particulate on Polycarbonate Track Etched (PCTE) filters, Teflon®, or Kapton® impaction surfaces. The filter are then returned to the laboratory and analyzed by Proton Induced X-ray Emission Spectroscopy (PIXE). The trace element concentrations of each fraction are determined with nondestructive proton induced X-ray system. The data are processed by a computer to yield micrograms of trace element per square centimeter ($\mu\text{g}/\text{cm}^2$) and/or $\mu\text{g}/\text{m}^3$ of metal constituents in air.

1.4 The PIXE method is a form of elemental analysis based on the characteristics of X-rays and the nature of X-ray detection. The method uses beams of energetic ions, produced by an accelerator to generate a beam of protons in the 2-5 MeV range, to create inner electron shell vacancies. As these inner shell vacancies are filled by outer shell electrons, the characteristic X-rays emitted by this cascade effect can be detected by wavelength dispersion. In this method, the X-rays are detected by Lithium drifted Silicon (SiLi) detectors and the electrical pulses from the detector transferred to the pulse processor.

1.5 Computer codes are used to perform data reduction of the acquired X-ray spectrum to produce

quantitative results. The method provides the sensitivity for accurate measurements at the nanogram or less level for many important trace metals in the urban atmosphere. The PIXE method has the capability to analyze a very small sample diameter in addition to evenly-distributed wide-area samples, which is advantageous because it permits analysis of individual particle size fractions collected with single orifice type cascade impactors.

2. Applicable Documents

2.1 ASTM Standards

- D1356 *Definition of Terms Related to Atmospheric Sampling and Analysis*.
- D1357 *Planning the Sampling of the Ambient Atmosphere*.

2.2 Other Documents

- *ASM Metals Handbook (9th Ed.) Vol 10. Materials Characterization*.
- U.S. Environmental Protection Agency, *Quality Assurance Handbook for Air Pollution Measurement Systems, Volume I: A Field Guide for Environmental Quality Assurance*, EPA-600/R-94/038a.
- U.S. Environmental Protection Agency, *Quality Assurance Handbook for Air Pollution Measurement Systems, Volume II: Ambient Air Specific Methods (Interim Edition)*, EPA-600/R-94/038b.
- *Scientific Publications of Ambient Air Studies (1-12)*.

3. Summary Of Method

3.1 Transport of Ambient Air Particulate Filters and Impaction Surfaces.

The filters and impaction surfaces transported from the sampling site to the laboratory are shipped in holders specially designed to avoid contamination and minimize particle loss, then sealed in ziplock plastic bags. Care should be exercised when handling the samples so as to prevent tearing, punctures, and contamination.

3.2 Multi-Element PIXE Analysis

The trace element concentrations of each filter or impaction surface are determined using proton excitation with energy-dispersive X-ray detection by a Lithium drifted Silicon (SiLi) detector with associated amplifiers and a multichannel analyzer. The X-ray detection system consists of an X-ray spectrometer and a pulse processor. After the X-ray detection system is calibrated with gravimetric standards, the sample filters or impaction surfaces are placed in the instrument and analyzed. The data output from the system is processed by computer to yield micrograms of trace element per square centimeter ($\mu\text{g}/\text{cm}^2$) and subsequently $\mu\text{g}/\text{m}^3$ of air. PIXE is one of the more commonly used elemental analysis methods because of its relatively low cost, nondestructive multi-element capabilities, high detection limits, and preservation of the filter for any additional chemical analyses.

4. Significance

4.1 PIXE analysis represents a broad range method for rapid measurement of air particulate matter collected by filtration and impaction. The mass of elements ranging from sodium to uranium are simultaneously

measured with a few minutes bombardment and evaluated by computer code in a similar time. As such, PIXE is a useful tool in monitoring both the behavior of the aerosol in time as well as its distribution among particle sizes. Since the method requires samples in the microgram range, it allows the use of air samplers of modest size and cost.

4.2 The area of toxic air pollutants has been the subject of interest and concern for many years. The use of receptor models has resolved the elemental composition of atmospheric aerosol into components related to emission sources. The assessment of human health impacts resulting in major decisions on control actions by federal, state, and local governments are based on these data.

5. Definitions

[Note: Definitions used in this document are consistent with ASTM methods. All pertinent abbreviations and symbols are defined within this document at point of use.]

5.1 Accuracy. The agreement between an experimentally determined value and the accepted reference value.

5.2 Attenuation. Reduction of amplitude or change in wave form due to energy dissipation or distance with time.

5.3 Calibration. The of comparing a standard or instrument with one of greater accuracy smaller uncertainty for the purpose of obtaining quantitative estimates of the actual values of the standard being calibrated, the deviation of the actual value from the nominal value, or the difference between the value indicated by an instrument and the actual value.

5.4 Emissions. The total of substances discharged into the air from a stack, vent, or other discrete source.

5.5 Filter. A porous medium for collecting particulate matter.

5.6 Fluorescent X-rays (Fluorescent Analysis). Characteristic X-rays emitted by excited atoms.

5.7 Impaction Surface. A non-porous medium for collecting particulate matter.

5.8 Inhalable Particles. Particles with aerodynamic diameter of $< 10 \mu\text{m}$ that can be inhaled into the human lung.

5.9 Interference. An overlap of spectral peaks due to two different elements.

5.10 Precision. The degree of mutual agreement between individual measurements, namely repeatability and reproducibility.

5.11 Standard. A concept that has been established by authority, custom, or agreement to serve as a model or rule in the measurement of quantity or the establishment of a practice or procedure.

5.12 Traceability to NIST. A documented procedure by which a standard is related to a more reliable standard verified by the National Institute of Standards Technology (NIST).

5.13 Uncertainty. An allowance assigned to a measured value to take into account two major components of error: systematic errors and random errors attributed to the imprecision of the measurement process.

6. Descriptions of Air Sampling and Analytical Systems

6.1 Air Particulate Samples

Aerosols, among other things, are comprised of particulates that are composed of elements in the form of compounds. These particulates range in size from submicron to $> 100 \mu\text{m}$. The mass of elements in these particulates are almost never uniformly distributed across the size range of the aerosol. The character or composition of aerosols is due to their proximity to local sources and any regional transport associated with the air flow. The EPA has mandated that particular attention should be paid to the particulates that are deemed respirable. This respirable range, defined as $< 10 \mu\text{m}$, is significant because this is the range of particles that can be retained in the lungs.

Because aerosols are dynamic, the aerosol with temporal resolutions ranging from 1 h to days should be studied. Numerous devices are available that can fractionate the aerosol while providing the temporal resolution desired.

6.2 Air Sampling Media (filters and impaction surfaces)

For optimum results using PIXE analysis, samples should be collected on the thinnest possible backing materials composed exclusively from low atomic number elements such as carbon, hydrogen, oxygen or nitrogen. PCTE (Polycarbonate Track Etched) and Teflon® filters are often used, as are impaction surfaces such as Kapton® and Mylar®. Thicknesses should not exceed $1,000 \mu\text{g}/\text{cm}^2$ to keep the background during PIXE analysis low and therefore provide the best detection limits. Thick filters or thick particle deposits on the filter substrate will scatter the excitation protons and lower the signal-to-noise ratio.

6.3 Air Particulate Samplers

Samples collected by many samplers are analyzed via PIXE analysis. The most extensive use has been on those from the dichotomous sampler, as documented in Inorganic Compendium Method IO-2.2, and the Partisol® sampler, as documented in Inorganic Compendium Method IO-2.3.

6.4 Description of PIXE Analysis System

A PIXE analysis system typically consists of an accelerator that produces a proton beam in the range of 2 to 5 MEV, a beam transport system, optics, and a chamber for analysis. The detectors monitor the X-rays generated and the number of protons (charge) used to generate those X-rays. Lithium drifted Silicon (SiLi) detectors are commonly used to allow simultaneous collection of a range of X-rays generated by collision of the proton beam with the sample atoms. A typical PIXE arrangement in a thin target mode is depicted in Figure 1. Following is a description of a typical PIXE installation.

6.4.1 Accelerator.

6.4.1.1 The vertical 4MV Van De Graff accelerator HVEC model KN, with stainless steel electrode acceleration tube, produces and directs beams into a 90E analyzing magnet. Beam energy calibration is based upon measurements of the accurately known $^{13}\text{C}(p,n)^{13}\text{N}$ and $^7\text{Li}(p,n)^7\text{Be}$ neutron thresholds. The magnetic field intensity is measured by a proton resonance gaussmeter with frequency readout for proton energy. The beam proceeds horizontally from the analyzing magnet via a 51 mm diameter beam line through a control slit/ beam collimator assembly and magnetic quadrupole lens into the target chamber area. Cryogenic pumping is used at the target area, and a vacuum of 10^{-7} Torr is maintained during irradiation of targets.

6.4.1.2 Immediately behind the target chamber is the doorway to the control room, which houses both the accelerator controls and the data acquisition-analysis computer.

6.4.1.3 Samples are irradiated for a preset amount of charge as measured by a Tomlinson 2000 AEC rate meter and beam current integrator in which frequency output is gated off during busy periods in the counting system. Count rates are normally limited to 2,000 counts per second. For analysis of nonuniformly distributed samples, a homogeneous beam density is required, which is created with a quadrupole lens to focus the beam into a horizontal line that is then vertically swept across the collimators.

6.4.1.4 Automation of data acquisition in a PIXE analytic system is more than a convenience in that the accuracy required for quality assurance of final analytic results can best be achieved with a minimum of human operator intervention in a repetitive process. Analysis of air particulate samples requires accurate location of the samples. While a variety of encoders for angular position are available, an encoder was developed (based upon a 10-turn linear potentiometer) with advantages over standard units in cost, size, mounting convenience, and ease of interface to the computer.

6.4.2 Acquisition System Hardware.

6.4.2.1 The overall data acquisition system is diagramed in Figure 2 and consists of a mixture of CAMAC and NIM modules, with the exception of the stepping motor interface. Beam current integration is conventional with termination of a run by a preset scalar that monitors charge (exclusive of dead periods). Target positioning in the bombardment chamber is controlled by the computer via the Alpha Products interface and stepping motor. The position information is read as a voltage from a potentiometer by an Alpha 12 Bit Analog Input card, as shown in Figure 3. A 10-turn potentiometer was chosen for its small size (length 19 mm, diam. 22 mm), resolution (0.007%), linearity (0.20%), and dependability when operated in vacuum. For the sample holding wheel, both high and low mechanical stops are accurately located in the chamber so that the built-in stops of the potentiometer are not used. For a single 7.5E step of the motor, a 600:1 overall gear ratio results in a 0.0125E angular displacement.

6.4.2.2 Under a calibration routine, the stepping motor is operated at a conservative rate (to insure dependable stepping) to establish the nonlinear characteristic of the particular potentiometer. This information is stored in a table of position versus voltage and thereafter utilized for correct angular positioning of the sample holding wheel. As shown in Figure 3, a panel meter is provided for general indication to the operator; however, it does not reflect the nonlinearity correction. A switch is used to select meter calibration resistance so that steeper position is read in hours while a discrete eight position sample holder, used for individual targets, appears as digits 0 through 7.

6.4.3 Acquisition System Codes.

6.4.3.1 The software for the data acquisition is written in Microsoft Quick BASIC, version 3.0. This software was chosen for the following reasons:

- Allows structured code (e.g., IF...THEN...ELSE).
- Allows true subroutine and function calls (Format same as FORTRAN).
- Graphic functions are built into the language.
- Runs in "interpretive" mode for development and testing and uses compiled code for actual data acquisition.
- Direct access to absolute memory and I/O ports, enabling simple interface to special devices such

as CAMAC, Alpha Products controller, etc.

6.4.3.2 The system is menu-driven and uses the cursor keys to control pull down menus. Both live mode and acquisition mode are available options. The system features many safeguards under the acquisition mode to protect data from being overwritten or erased inadvertently. Provisions for archival and retrieval are also available under the tape options menu. Complete chain of custody identifiers, including tape labels, run numbers, irradiation date and time, sample identification, client, job number, and duration of irradiation are required prior to beginning data acquisition. All identifiers are written on the disk, along with the spectrum, as a single record in a random access file. Thus, no data collected can be written without identification information. Each file is capable of storing up to 500 1024 channel spectra in approximately two megabytes of disk space. The tape archival/retrieval submenu utilizes an escape to DOS/Batch file execution process, so that any commercially available archival program can be used for long-term data crunching and storage. PCTOOLS Backup/Restore utilities are being used successfully for this purpose, but other packages could also be employed. The tape options submenu also includes the ability to store up to six archived files (each containing 500 spectra) on the disk and allows the user to select any archived tape for spectral display.

6.4.3.3 Under acquisition, mode control is transferred to the CAMAC crate until scaler presets for irradiation duration are reached. Update frequency is approximately every 3-5 s to the screen. Once irradiation is complete, data must be written on disk or erased before the next sample irradiation can begin. A complete log file is maintained, which stores all write-and-erase operations and is transparent to the user. Another useful feature available under the acquisition mode is the auto/manual option. This option allows the user to run one irradiation at a time or set up for automated irradiation and stepping to the next target so that multiple irradiations can be completed without further user intervention. This feature is particularly advantageous for sequential type samples.

6.4.3.4 The system is also capable of displaying up to three spectra simultaneously with options for multiple overlaying, addition, subtraction, square root, and linear scaling, expansion between markers, overlay of multiple spectra, and peak energy identification. Computer hardware requirements are an IBM PC with an 80386 or later CPU, serial and parallel ports, an external floppy drive, and at least a 20 megabyte hard disk.

6.5 Laboratories with PIXE Capability

Positive ion accelerators capable of proton energies of 2 million volts and above generally are used to bombard samples and produce the characteristic X-rays. Beam diameters range from μm to centimeters. Approximately 100 laboratories having PIXE capability were counted in 1990.

7. X-ray Spectra

7.1 X-ray Production

The air particulate sample is placed in an evacuated (or helium-filled) chamber and subjected to bombardment by the proton beam. The resulting characteristic X-rays are detected by an energy dispersive (SiLi) detector with an associated pulse processor and multichannel pulse height analyzer producing a display of the peaks. A spectrum for an indoor industrial aerosol is shown in Figure 4. For a typical system, the efficiency for producing and detecting of the X-rays is shown as Figure 5. Using K, L, and M lines, the elements F and above are observable with varying sensitivities.

7.2 Computing Methods for Spectral Analysis

Several well documented computer codes are available to perform data reduction of the acquired X-ray spectrum to produce quantitative results. A typical example of a code that produces an automated evaluation of spectra is the computer code HEX, originally named REX. This code uses a library of measured X-ray intensities for each element, as determined from gravimetric thin film standards, to simultaneously fit the entire spectrum. The quality of the fit is judged by a non-linear least squares analysis. The background continuum is fit by a ninth order constrained polynomial. Interferences are accounted for in the fitting process since the library contains all the lines of each element and their ratios to one another. In the example shown as Figure 4, lines are drawn through both the fit and the background.

7.3 Elemental Mass Per Unit Area

From the spectral analysis, the mass per unit area of an element is found using the previously measured efficiency curves (shown in Figure 4). PIXE is an absolute analysis method in that the efficiency curve is fundamentally due to the physics of the atom, as reflected in the X-ray production cross-section curve for a specific proton energy. Such curves are functions that mirror the changes in the electronic structure of the inner shells of atoms as the atomic number increases. Therefore, they provide an additional criteria by which the accuracy of gravimetric standards can be verified.

The measured efficiency in the calibration of a particular laboratory system also includes the effects of solid angle subtended by the detector and the absorption of X-rays in reaching the detector. The measured efficiency, referred to as the sensitivity curve, has units of counts per microgram per centimeter squared per microCoulomb of collected charge, $\text{cts}/(\mu\text{g}/\text{cm}^2)/(\mu\text{C})$. To convert the output of the spectral fitting to a quantifiable value, $\mu\text{g}/\text{cm}^2$, the number of integrated counts in a peak is divided by the sensitivity for that element and the amount of charge collected to acquire the spectrum. For non-uniform samples (such as those from impactors), a proton beam of uniform areal density envelops the sample, which results in a measurement of the mass of the elements within the beam envelope instead of mass/area.

7.4 Atmospheric Aerosol Concentrations

The mass per unit volume of sampled air, $\mu\text{g}/\text{m}^3$, is found by multiplying the mass/area by the sample area and dividing by the volume of air V_{std} used to collect the sample, corrected to EPA's standard temperature (25EC) and standard pressure (760 mmHg). The sampled air volume is corrected to EPA reference conditions by:

$$V_{\text{std}} = V_s \left(\frac{T_{\text{std}}}{T_m} \right) \left(\frac{P_{\text{bar}}}{P_{\text{std}}} \right)$$

where:

- V_{std} = volume of ambient air sampled at EPA-reference conditions, m^3 .
- V_s = volume of ambient air pulled through the sampler, m^3 .
- T_{std} = absolute EPA-reference temperature, 298EK.
- T_m = average ambient temperature, EK.

P_{bar} = barometric pressure during sampling measurement condition, mmHg.
 P_{std} = EPA-reference barometric pressure, 760 mmHg.

7.5 Detection Limits

A detection limit for each element can be calculated using the calibrated sensitivity curve (Figure 5); however, this figure is not a good figure of merit because it represents the best case sensitivity for single (or two element) standards on very thin backings with no consideration as to what other factors affect detection limits. A more realistic approach for typical detection limits for a PIXE analysis in aerosol measurement should also include the sampling substrate material as shown in Table 1. This table lists minimum detection limits (in ng/cm²) for three commonly used filter substrates—Teflon® 2 µm pore size, mixed cellulose ester, and PCTE® 0.4 µm pore size. Minimum detection limit is defined here as the mass/area that is required to produce a peak spectral area that exceeds the background by a factor of three. In Table 1, the Teflon® filters detection limits are higher than those of PCTE and cellulose filters due largely to the additional background produced by inelastic scattering from the ¹⁹F nucleus with the impinging proton at beam energies used in PIXE analysis.

A detection limit in terms of atmospheric concentration can only be stated if the corresponding sample flowrate and time of sample collection are specified.

8. Quality Control and Assurance

The objective of a laboratory quality control and assurance program is to assure the accuracy, precision, and reliability of the laboratory results for its customers. As such, the QA/QC program must be all-encompassing and start well before any analysis is ever performed. Numerous sources for establishing a QA/QC program, including those outlined in the section on XRF analysis for NEA, Inc., have been established. Protocols for establishing such programs are also available from EPA, NIOSH, Industrial Hygiene Association, American Association for Laboratory Accreditation, ISO9000, ANSI/ASQC, etc.

9. Precision and Accuracy

9.1 Precision

Precision is defined as the ability for a measurement to be reproduced. Many factors can affect the stability of a measurement system that would alter its precision. Stability of the system parameters should be constantly monitored to ensure minimal variability. In PIXE these variables include beam energy, sample position, current integration, detector solid angle and efficiency, and system transmission. A good QA/QC program will include routine monitoring of these variables through the use of standards validation to ensure a high degree of precision. In general, a PIXE laboratory with such protocols in place should be able to maintain precision to about $\pm 1.5\%$ relative for its standards; that is, a standard of $5.0 \mu\text{g}/\text{cm}^2$ should be reproducible from $4.925\text{-}5.075 \mu\text{g}/\text{cm}^2$.

9.2 Accuracy

Accuracy is somewhat more difficult to define for aerosol samples. The usual procedure as outlined above would entail calibration with known thin film standards. These standards have a certain error associated with them in accordance with their methods of preparation. Many laboratories use thin films from MicroMatter, Inc., which certifies their values at $\pm 5\%$ based on gravimetric determinations. This uncertainty can be reduced somewhat based upon the known sensitivity curves for the elements, as described above under Section 7.3. Since the curves are continuous functions, outliers in the suite of standards used for calibration can be readily determined. In addition, standards obtained from other sources (for example, NIST) can further reduce this error. In general, considering all possible sources of error, analytical accuracies usually can be held to about $\pm 2.5\%$ for the standards.

Defining accuracies is somewhat more difficult for aerosol samples since errors associated with sampling procedures, as well as analytical errors due to self-absorption on large particles, are much more difficult to quantify. Although statistical procedures have been developed to correct for self-absorption on large particles, they are only approximations based upon a uniform distribution of the trace elements with the particles themselves. Of course, this assumption can never be known a priori and hence always remains an uncertainty. For small particles, this uncertainty is not a problem since self-absorption is minimal. The best methodologies for determining absolute accuracies for aerosol samples would have to involve inter-comparisons among samplers under various experimental conditions as well as inter-laboratory comparisons on the same filters to validate technique biases. Many such experiments have been conducted using many different types of samplers followed by analysis using ICP, AA, XRF, PIXE, and neutron activation. Absolute uncertainties of 10-20% on an element analysis are not uncommon in such comparisons.

10. References

1. Bauman, S., Nelson, J.W., and Hudson, G.M., "An Ion Beam Analysis Facility," *Proc. IEEE Trans. Nucl. Sci.*, NS-28:1374, 1981.
2. Cahill, T.A., "Particle Induced X-ray Emission", *ASM Metals Handbook*, 9th Ed., Vol. 10:213.
3. Bauman, S., Houmère, P.D., Leonard, R., and Nelson, J.W., "A Dedicated PIXE Analysis Laboratory Based upon a 4 MV Van De Graaff Accelerator," *Nucl. Inst. and Meth.*, Vol B3:119, 1984.
4. Johansson, J.E., et al., "Automation in PIXE Data Acquisition," *Nucl. Inst. and Meth.*, Vol B49:179, 1990.
5. Norman, L., et al., "A Bombardment Chamber for PIXE Analysis," *Nucl. Inst. and Meth.*, Vol B3:122, 1984.
6. Bauman, S., Houmère, P.D., and Nelson, J.W., "Cascade Impactor Aerosol samples for PIXE and PESA Analysis," *Nucl. Inst. and Meth.*, Vol. 181:499, 1981.
7. Cahill, T.A., Miranda, J. and Morales, R., "Survey of PIXE Programs - 1991," *Int. Jour. of PIXE*, Vol. 1:297, 1991.
8. Kaufmann, H.C., Akselsson, K.R., and Courtney, W.J., "REX - A Computer Programme for PIXE Analysis," *Nucl. Inst. and Meth.*, Vol. 142:251, 1977.
9. Nelson, R.O. and Nelson, J.W., "A Programable Controller for the Streaker® Air Sampler," *Nucl. Inst. and Meth.*, Vol. B22:353, 1987.
10. Cahill, T.A., et al., "The Stacked Filter Unit Revisited," *Visibility and Fine Particles*, Ed. C.V. Mathai, 213, 1990.
11. Johansson, S.A.E., and Campbell, J.L., *PIXE: A Novel Technique for Elemental Analysis*, Wiley, 1988.
12. Dzubay, T.G. (Ed.), *X-ray Fluorescence Analysis of Environmental Samples*, Ann Arbor Sci. Publ., 1977.

TABLE 1. METHOD DETECTION LIMIT FOR PIXE ANALYSIS ¹

Teflon® Filter			Teflon® Filter		
Element	(ng/cm ²)	(ng/m ³)	Element	(ng/cm ²)	(ng/m ³)
Na	94	28.28	In	761	239.88
Mg	62	18.66	Sn	906	272.64
Al	54	16.25	Sb	1250	376.16
Si	47	14.14	Te	103	30.99
P	48	14.44	I	97	29.19
S	43	12.94	Cs	84	25.28
Cl	41	12.34	Ba	75	22.57
K	33	9.93	La	69	20.76
Ca	27	8.12	Ce	60	18.06
Sc	26	7.82	Pr	53	15.95
Ti	22	6.62	Nd	50	15.05
V	18	5.42	Pm	42	12.64
Cr	13	3.91	Sm	40	12.04
Mn	10	3.01	Eu	35	10.53
Fe	9	2.71	Gd	34	10.23
Co	8	2.37	Tb	31	9.34
Ni	8	2.37	Dy	32	9.63
Cu	9	2.71	Ho	31	9.34
Zn	12	3.61	Er	29	8.73
Ga	12	3.61	Tm	34	10.23
Ge	14	4.21	Yb	35	10.53
As	18	5.42	Lu	36	10.83
Se	21	6.32	Hf	35	10.53
Br	41	12.34	Ta	36	10.83
Rb	59	17.75	W	40	12.04
Sr	77	23.17	Re	44	13.24
Y	95	28.59	Os	43	12.94
Zr	117	35.51	Ir	41	12.34
Nb	148	43.63	Pt	45	13.54
Mo	190	57.17	Au	48	14.44
Tc	243	73.12	Hg	48	14.44
Ru	297	89.37	Tl	55	16.55
Rh	348	104.72	Pb	59	16.85
Pd	446	134.21	Bi	59	16.85
Ag	551	165.81	Th	112	33.70
Cd	670	201.62	U	146	43.94

¹Based upon dichotomous sampling for 24-hours using a 37-mm Teflon® filter at a sampling rate of 0.9 m³/hr.

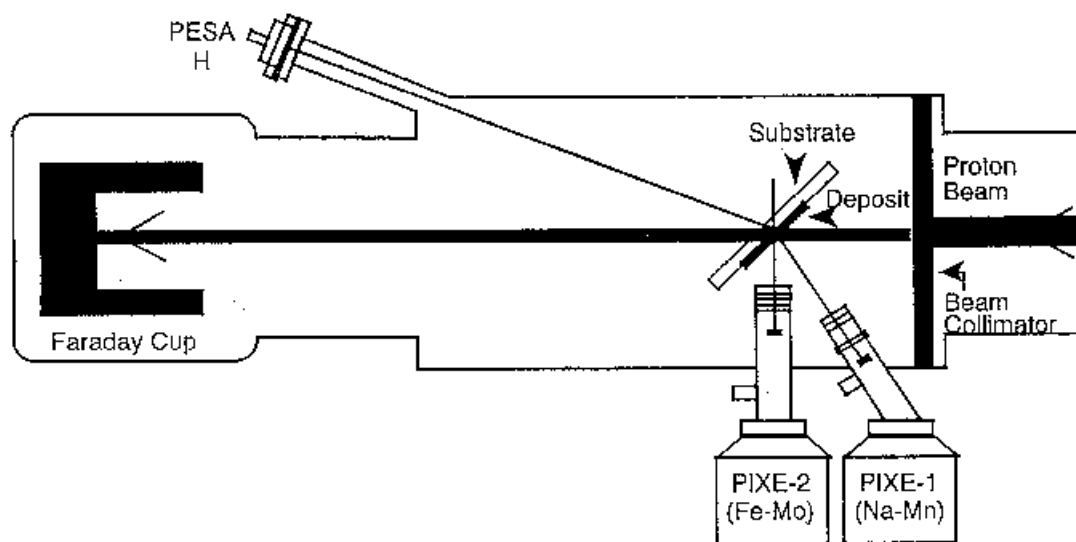

Figure 1. Example of schematic of a typical PIXE thin target system.

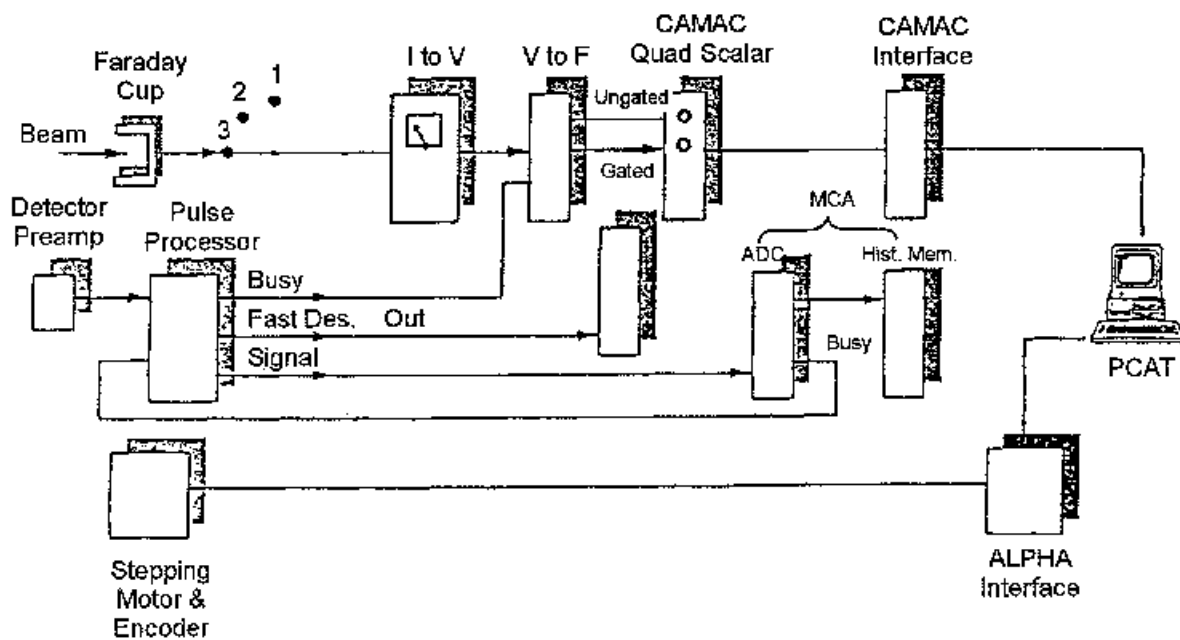

Figure 2. Example of PIXE Data Acquisition System.

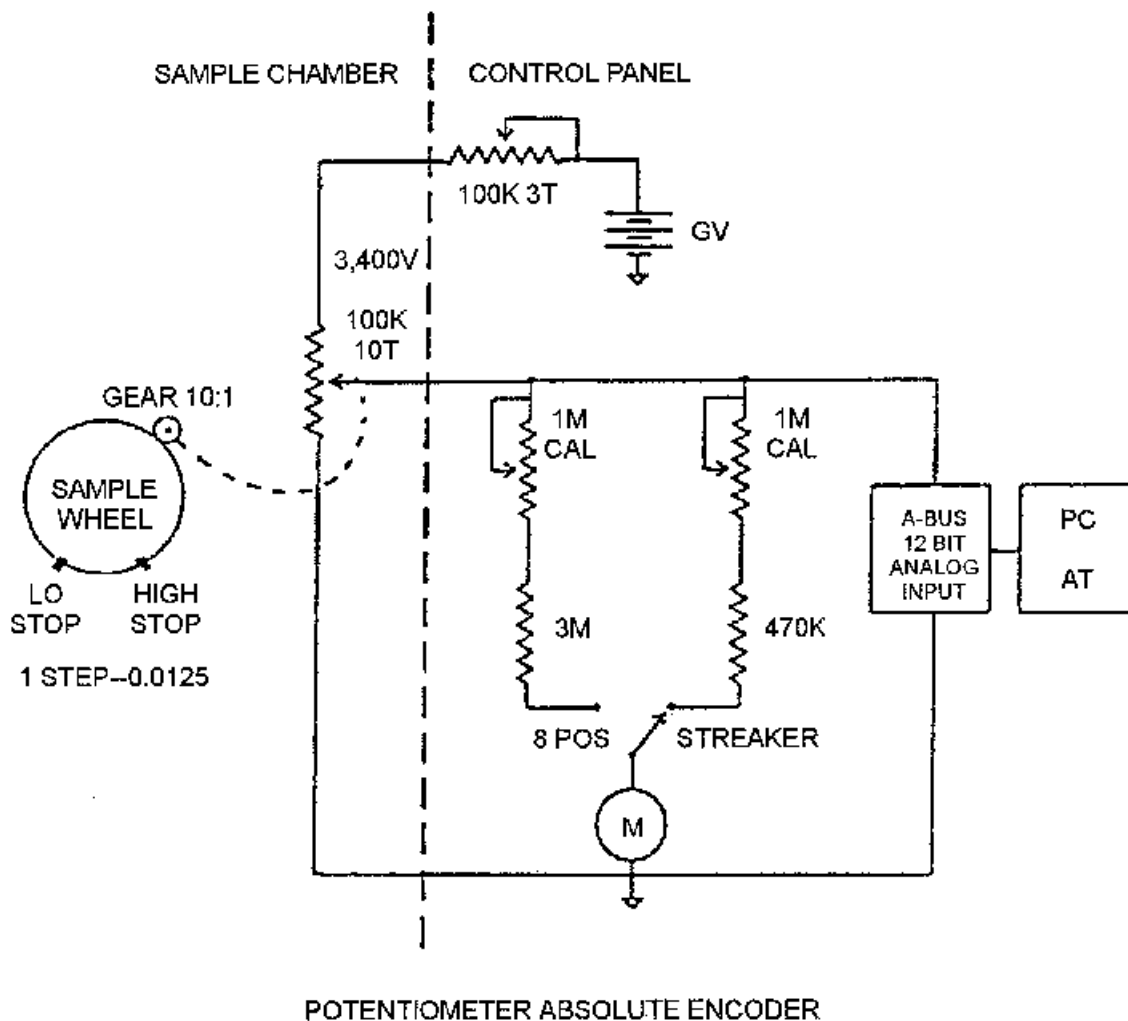

Figure 3. Absolute angular encoder based upon a ten-turn linear potentiometer.

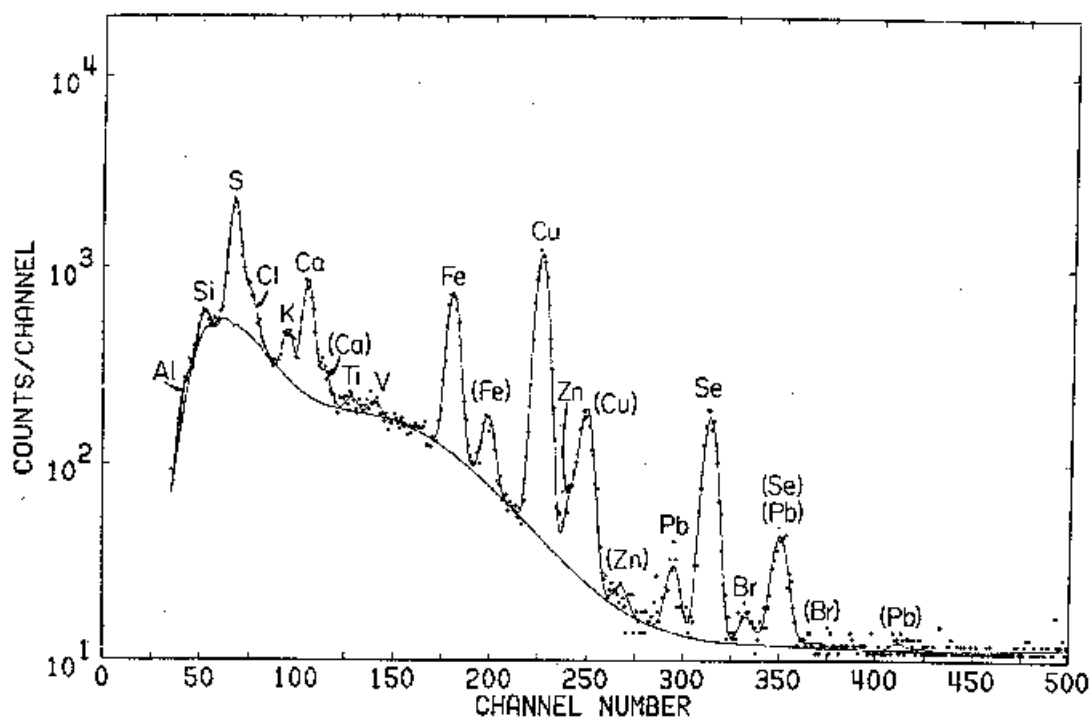

Figure 4. Example of spectrum for an indoor industrial aerosol.

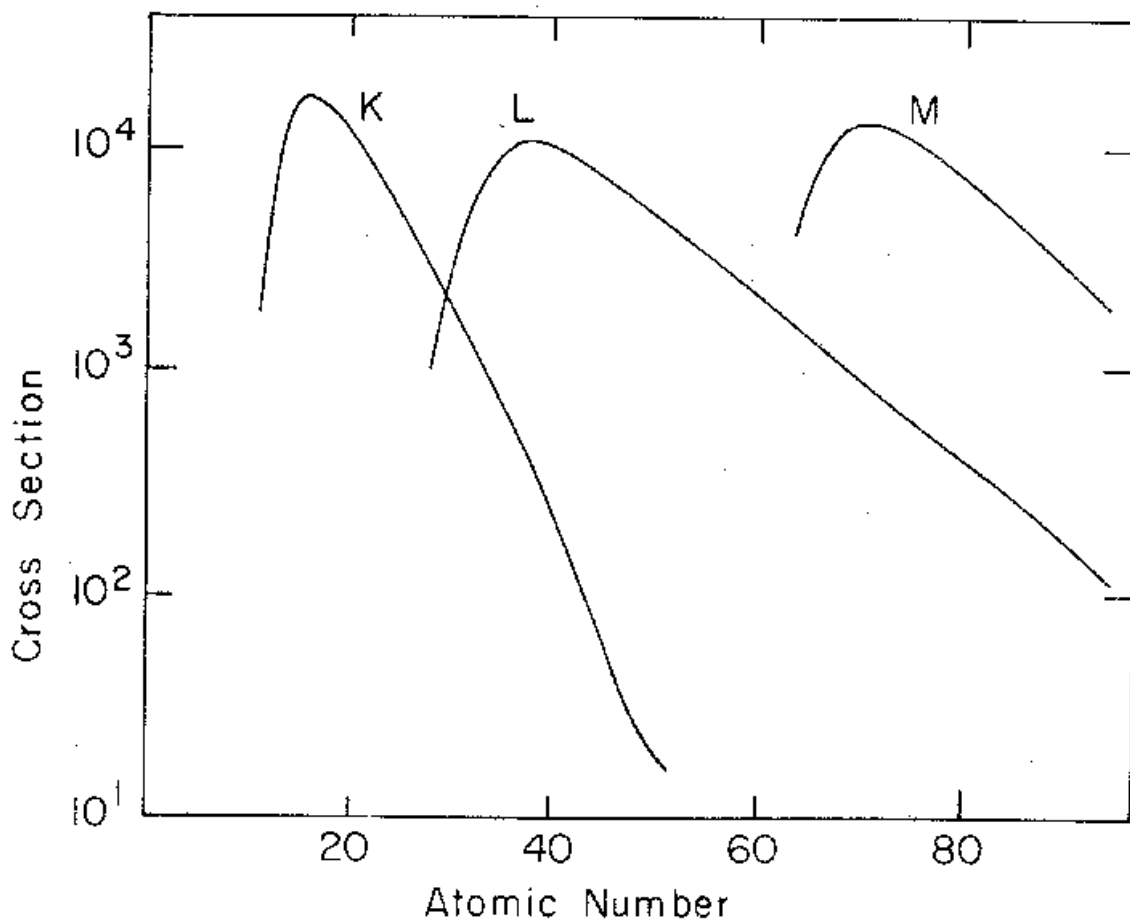

Figure 5. Example of efficiency for production and detection of x-rays.