

METHOD T0-7

METHOD FOR THE DETERMINATION OF N-NITROSODIMETHYLAMINE
IN AMBIENT AIR USING GAS CHROMATROGRAPHY

1. Scope

- 1.1 This document describes a method for determination of N-nitrosodimethylamine (NDMA) in ambient air. Although the method, as described, employs gas chromatography/mass spectrometry (GC/MS), other detection systems are allowed.
- 1.2 Although additional documentation of the performance of this method is required, a detection limit of better than 1 ug/m³ is achievable using GC/MS (1,2). Alternate, selective GC detection systems such as a thermal energy analyzer (2), a thermionic nitrogen-selective detector (3), or a Hall Electrolytic conductivity detector (4) may prove to more sensitive and selective in some instances.

2. Applicable Documents

- 2.1 ASTM Standards
D1356 Definitions of Terms Related to Atmospheric Sampling and Analysis (5)
- 2.2 Other Documents
Ambient air studies (1,2)
U.S. EPA Technical Assistance Document (6)

3. Summary of Method

- 3.1 Ambient air is drawn through a Thermosorb/N adsorbent cartridge at a rate of approximately 2 L per minute for an appropriate period of time. Breakthrough has been shown not to be a problem with total sampling volumes of 300 L (i.e., 150 minutes at 2 L per minute). The selection of Thermosorb/N adsorbent over Tenax GC, was due, in part, to recent laboratory studies indicating artifact formation on Tenax from the presence of oxides of nitrogen in the sample matrix.
- 3.2 In the laboratory, the cartridges are pre-eluted with 5 mL of dichloromethane (in the same direction as sample flow) to remove interferences. Residual dichloromethane is removed by purging the

cartridges with air in the same direction. The cartridges are then eluted, in the reverse direction, with 2 mL of acetone. This eluate is collected in a screw-capped vial and refrigerated until analysis.

- 3.3 NDMA is determined by GC/MS using a Carbowax 20M capillary column. NDMA is quantified from the response of the m/e 74 molecular ion using an external standard calibration method.

4. Significance

- 4.1 Nitrosamines, including NDMA, are suspected human carcinogens. These compounds may be present in ambient air as a result of direct emission (e.g., from tire manufacturing) or from atmospheric reactions between secondary or tertiary amines and NO_x.

- 4.2 Several papers (1,2,4) have been published describing analytical approaches for NDMA determination. The purpose of this document is to combine the attractive features of these methods into one standardized method. At the present time, this method has not been validated in its final form, and, therefore, one must use caution when employing it for specific applications.

5. Definitions

Definitions used in this document and in any user-prepared SOPs should be consistent with ASTM D1356(5). All abbreviations and symbols are defined within this document at the point of use.

6. Interferences

Compounds having retention times similar to NDMA, and yielding detectable m/e 74 ion fragments, may interfere in the method. The inclusion of a pre-elution step in the sample desorption procedure minimizes the number of interferences. Alternative GC columns and conditions may be required to overcome interferences in unique situations.

7. Apparatus

- 7.1 GC/MS System - capable of temperature-programmed, fused-silica capillary column operation. Unit mass resolution or better to 300 amu. Capable of full scan and selected ion monitoring with a scan rate of 0.8 second/scan or better.
- 7.2 Sampling system - capable of accurately and precisely sampling 100-2000 mL/minute of ambient air. (See Figure 1.) The dry test meter may not be accurate at flows below 500 mL/minute; in such cases it should be replaced by recorded flow readings at the start, finish, and hourly during the collection. See Section 9.4.
- 7.3 Stopwatch.
- 7.4 Friction top metal can, e.g., one-gallon (paint can) - to hold clean cartridges and samples.
- 7.5 Thermometer - to record ambient temperature.
- 7.6 Barometer (optional).
- 7.7 Glass syringe - 5 mL with Luer[®] fitting.
- 7.8 Volumetric flasks - 2 mL, 10 mL, and 100 mL.
- 7.9 Glass syringe - 10 μ L for GC injection.

8. Reagents and Materials

- 8.1 Thermosorb/N - Available from Thermedics Inc., 470 Wildwood St., P.O. Box 2999, Woburn, Mass., 01888-1799, or equivalent.
- 8.2 Dichloromethane - Pesticide quality, or equivalent.
- 8.3 Helium - Ultrapure compressed gas (99.9999%).
- 8.4 Perfluorotributylamine (FC-43) - for GC/MS calibration.
- 8.5 Chemical Standards - NDMA solutions. Available from various chemical supply houses. Caution: NDMA is a suspected human carcinogen. Handle in accordance with OSHA regulations.
- 8.6 Granular activated charcoal - for preventing contamination of cartridges during storage.
- 8.7 Glass jar, 4oz- to hold cartridges.
- 8.8 Glass vial - 1 dram, with Teflon[®] -lined screw cap.
- 8.9 Luer[®] fittings - to connect cartridges to sampling system.
- 8.10 Acetone - Reagent grade.

9. Sampling

- 9.1 Cartridges (Thermosorb/N) are purchased prepacked from Thermedics Inc. These cartridges are 1.5 cm ID x 2 cm long polyethylene tubes with Luer[®]-type fittings on each end. The adsorbent is held in place with 100-mesh stainless steel screens at each end. The cartridges are used as received and are discarded after use. At least one cartridge from each production lot should be used as a blank to check for contamination. The cartridges are stored in screw-capped glass jars (with Luer[®] style caps), and placed in a charcoal-containing metal can when not in use.
- 9.2 The sampling system may employ either a mass flow controller or a dry test meter. (See Figure 1.) For purposes of discussion, the following procedure assumes the use of a dry test meter.
- 9.3 Before sample collection, the entire assembly (including a "dummy" sampling cartridge) is installed and the flow rate is checked at a value near the desired rate. In general, flow rate of 100-2000 mL/minute should be employed. The flow rate should be adjusted so that no more than 300 L of air is collected over the desired sampling period. Generally, calibration is accomplished using a soap bubble flow meter or calibrated wet test meter connected to the flow exit, assuming the system is sealed. ASTM Method 3686 describes an appropriate calibration scheme not requiring a sealed flow system downstream of the pump.
- 9.4 Ideally, a dry gas meter is included in the system to record total flow. If a dry gas meter is not available, the operator must measure and record the sampling flow rate at the beginning and end of the sampling period to determine sample volume. If the sampling period exceeds two hours, the flow rate should be measured at intermediate points during the sampling period. Ideally, a rotameter should be included to allow observation of the flow rate without interruption of the sampling process.
- 9.5 To collect an air sample, a new Thermosorb/N cartridge is removed from the glass jar and connected to the sampling system using a Luer[®] adapter fitting. The glass jar is sealed for later use. The following parameters are recorded on the data sheet (see Figure 2 for an example): date, sampling location, time, ambient temperature, barometric pressure (if available), relative humidity (if available), dry gas meter reading (if appropriate), flow rate, rotameter setting, cartridge batch number, and dry gas meter and pump identification numbers.

- 9.6 The sampler is allowed to operate for the desired period, with periodic recording of the variables listed above. The total flow should not exceed 300 L.
- 9.7 At the end of the sampling period, the parameters listed in Section 9.5 are recorded and the sample flow is stopped. If a dry gas meter is not used, the flow rate must be checked at the end of the sampling interval. If the flow rates at the beginning and end of the sampling period differ by more than 15%, the sample should be marked as suspect.
- 9.8 Immediately after sampling, the cartridge is removed from the sampling system, capped, and placed back in the 4-oz glass jar. The jar is then capped, sealed with Teflon[®] tape, and placed in a friction-top can containing 1-2 inches of granular charcoal. The samples are stored in the can until analysis.
- 9.9 If a dry gas meter or equivalent total flow indicator is not used, the average sample flow rate must be calculated according to the following equation:

$$Q_A = \frac{Q_1 + Q_2 + \dots + Q_N}{N}$$

where

- Q_A = average flow rate (mL/minute).
- Q_1, Q_2, \dots, Q_N = flow rates determined at beginning, end, and immediate points during sampling.
- N = number of points averaged.

- 9.10 The total flow is then calculated using the following equation:

$$V_m = \frac{(T_2 - T_1) \times Q_A}{1000}$$

where

- V_m = total sample volume (L) at measured temperature and pressure.
- T_2 = stop time.
- T_1 = start time.
- $T_2 - T_1$ = sampling time (minutes).

- 9.11 The total volume (V_s) at standard conditions, 25°C and 760 mm Hg, is calculated from the following equation:

$$V_s = V_m \times \frac{P_A}{760} \times \frac{298}{273 + t_A}$$

- where V_s = total sample volume (L) at standard conditions of 25°C and 760 mm Hg.
- V_m = total sample volume (L) at measured temperature and pressure.
- P_A = average barometric pressure (mm Hg).
- t_A = average ambient temperature (°C).

10. Sample Desorption

- 10.1 Samples are returned to the laboratory and prepared for analysis within one week of collection.
- 10.2 Using a glass syringe, the samples are pre-eluted to remove potential interferences by passing 5 mL of dichloromethane through the cartridge, in the same direction as sample flow. This operation should be conducted over approximately a 2-minute period. Excess solvent is expelled by injecting 5 mL of air through the cartridge, again using the glass syringe.
- 10.3 The NDMA is then desorbed passing 2 mL of acetone through the cartridge, in the direction opposite to sample flow, using a glass syringe. A flow rate of approximately 0.5 mL/minute is employed and the eluate is collected in a 2-mL volumetric flask.
- 10.4 Desorption is halted once the volumetric flask is filled to the mark. The sample is then transferred to a 1-dram vial having a Teflon[®]-lined screw cap and refrigerated until analysis. The vial is wrapped with aluminum foil to prevent photolytic decomposition of the NDMA.

11. GC/MS Analysis

Although a variety of GC detectors can be used for NDMA determination, the following procedure assumes the use of GC/MS in the selected ion monitoring (SIM) mode.

11.1 Instrument Setup

11.1.1 Considerable variation in instrument configuration is expected from one laboratory to another. Therefore, each laboratory must be responsible for verifying that its particular system yields satisfactory results. The GC/MS system must be capable of accommodating a fused-silica capillary column, which can be inserted directly into the ion source. The system must be capable of acquiring the processing data in the selected ion monitoring mode.

11.1.2 Although alternative column systems can be used, a 0.2 mm I.D. x 50 m Carbowax 20M fused-silica column (Hewlett-Packard Part No. 19091-60150, or equivalent) is recommended. After installation, a helium carrier gas flow of 2 mL per minute is established and the column is conditioned at 250°C for 16 hours. The injector and GC/MS transfer line temperatures should also be set at 250°C.

11.1.3 The MS and data system are set up according to manufacturer's specifications. Electron impact ionization (70eV) should be employed. Once the entire GC/MS system is set up, it is calibrated as described in Section 11.2. The user should prepare a detailed standard operating procedure (SOP) describing this process for the particular instrument being used.

11.2 Instrument Calibration

11.2.1 Tuning and mass standardization of the MS system is performed according to manufacturer's instructions and relevant information from the user-prepared SOP. Perfluorotributylamine should generally be employed for this purpose. The material is introduced directly into the ion source through a molecular leak. The instrumental parameters (e.g., lens, voltages, resolution, etc.) should be adjusted to give the relative ion abundances shown in Table 1 as well as acceptable resolution and peak shape. If these approximate relative abundances cannot be achieved, the ion source may require cleaning according to manufacturer's instructions. In the event that the user's instrument cannot achieve these relative ion

abundances, but is otherwise operating properly, the user may adopt another set of relative abundances as performance criteria. However, these values must be repeatable on a day-to-day basis.

11.2.2 After the mass standardization and tuning process has been completed and the appropriate values entered into the data system, the user should set the SIM monitoring parameters (i.e., mass centroid and window to be monitored) by injecting a moderately high level standard solution (100 ug/mL) of NDMA onto the GC/MS in the full scan mode. The scan range should be 40 to 200 amu at a rate of 0.5 to 0.8 scans/second. The nominal mass 42, 43, and 74 amu ions are to be used for SIM monitoring, with the 74 amu ion employed for NDMA quantification.

11.2.3 Before injection of NDMA standards, the GC oven temperature is stabilized at 45°C. The filament and electron multiplier voltage are turned off. A 2-uL aliquot of an appropriate NDMA standard, dissolved in acetone, is injected onto the GC/MS system using the splitless injection technique. Concentrated NDMA standards can be purchased from chemical supply houses. The standards are diluted to the appropriate concentration with acetone. CAUTION: NDMA is a suspected carcinogen and must be handled according to OSHA regulations. After five minutes, the electron multiplier and filament are turned on, data acquisition is initiated, and the oven temperature is programmed to 250°C at a rate of 16°C/minute. After elution of the NDMA peak from the GC/MS (Figure 3), the data acquisition process can be halted and data processing initiated.

11.2.4 Once the appropriate SIM parameters have been established, as described in Section 11.2.2, the instrument is calibrated by analyzing a range of NDMA standards using the SIM procedure. If necessary, the electron multiplier voltage or amplifier gain can be adjusted to give the desired sensitivity for standards bracketing the range of interest. A calibration curve of m/e 74 ion intensity versus quantity of NDMA

injected is constructed and used to calculate NDMA concentration in the samples.

11.3 Sample Analysis

11.3.1 The sample analysis process is the same as that described in Section 11.2.3 for calibration standards. Samples should be handled so as to minimize exposure to light.

11.3.2 If a peak is observed for NDMA (within ± 6 seconds of the expected retention time), the areas (integrated ion intensities) for m/e 42, 43, and 74 are calculated. The area of m/e 74 peak is used to calculate NDMA concentration. The ratios of m/e 42/74 and 43/74 ion intensities are used to determine the certainty of the NDMA identification. Ideally, these ratios should be within $\pm 20\%$ of the ratios for an NDMA standard in order to have confidence in the peak identification. Figure 4 illustrates the MS scan for N-nitrosodimethylamine.

12. Calculations

12.1 Calibration Response Factors

12.1.1 Data from calibration standards are used to calculate a response factor for NDMA. Ideally, the process involves analysis of at least three calibration levels of NDMA during a given day and determination of the response factor (area/ng injected) from the linear least squares fit of a plot of nanograms injected versus area (for the m/e 74 ion). In general, quantities of NDMA greater than 1000 nanograms should not be injected because of column overloading and/or MS response nonlinearity.

12.1.2 If substantial nonlinearity is present in the calibration curve, a nonlinear least squares fit (e.g., quadratic) should be employed. This process involves fitting the data to the following equation:

$$Y = A + BX + CX^2$$

where

Y = peak area

X = quantity of NDMA (ng)

A, B, and C are coefficients in the equation

12.2 NDMA Concentration

- 12.2.1 Analyte quantities on a sample cartridge are calculated from the following equation:

$$Y_A = A + BX_A + CX_A^2$$

where

Y_A is the area of the m/e 74 ion for the sample injection.

X_A is the calculated quantity of NDMA (ng) on the sample cartridge.

A, B, C are the coefficients calculated from the calibration curve described in Section 12.1.2.

- 12.2.2 If instrumental response is essentially linear over the concentration range of interest, a linear equation (C=0 in the equation above) can be employed.

- 12.2.3 Concentration of analyte in the original air sample is calculated from the following equation:

$$C_A = \frac{X_A}{V_s}$$

where

C_A is the calculated concentration of analyte (ng/L).

V_s and X_A are as previously defined in Sections 9.11 and 12.2.1, respectively.

13. Performance Criteria and Quality Assurance

13.1 Standard Operating Procedures (SOPs).

- 13.1.1 User should generate SOPs describing the following activities in their laboratory: 1) assembly, calibration, and operation of the sampling system with make and model of equipment used; 2) preparation, purification, storage, and handling of Thermosorb/N cartridges and samples; 3) assembly, calibration, and operation of the GC/MS system with make and model of equipment used; and 4) all aspects of data recording and processing, including lists of computer hardware and software used.

13.1.2 SOPs should provide specific stepwise instructions and should be readily available to and understood by the laboratory personnel conducting the work.

13.2 Sample Collection

13.2.1 During each sampling event, at least one clean cartridge will accompany the samples to the field and back to the laboratory, having been placed in the sampler but without sampling air, to serve as a field blank. The average amount of material found on the field blank cartridges may be subtracted from the amount found on the actual samples. However, if the blank level is greater than 25% of the sample amount, data for that component must be identified as suspect.

13.2.2 During each sampling event, at least one set of parallel samples (two or more samples collected simultaneously) should be collected. If agreement between parallel samples is not generally within $\pm 25\%$, the user should collect parallel samples on a much more frequent basis (perhaps for all sampling points).

13.2.3 Backup cartridges (two cartridges in series) should be collected with each sampling event. Backup cartridges should contain less than 10% of the amount of NDMA found in the front cartridges, or be equivalent to the blank cartridge level, whichever is greater.

13.2.4 NDMA recovery for spiked cartridges (using a solution-spiking technique) should be determined before initial use of the method on real samples. Currently available information indicates that a recovery of 75% or greater should be achieved.

13.3 GC/MS Analysis

13.3.1 Performance criteria for MS tuning and mass standardization are discussed in Section 11.2 and Table 1. Additional criteria can be used by the laboratory, if desired. The following section provide performance guidance and suggested criteria for determining the acceptability of the GC/MS system.

13.3.2 Chromatographic efficiency should be evaluated daily by the injection of NDMA calibration standards. The NDMA peak should be plotted on an expanded time scale so that its width at 10% of the peak height can be

calculated, as shown in Figure 5. The width of the peak at 10% height should not exceed 10 seconds. More stringent criteria may be required for certain applications. The asymmetry factor (see Figure 5) should be between 0.8 and 2.0.

13.3.3 The detection limit for NDMA is calculated from the data obtained for calibration standards. The detection limit is defined as

$$DL = A + 3.3S$$

where

DL is the calculated detection limit in nanograms injected.

A is the intercept calculated in Section 12.1.2.

S is the standard deviation of replicate determinations of the lowest-level standard (at least three such determinations are required). The lowest-level standard should yield a signal-to-noise ratio (from the total ion current response) of approximately 5.

13.3.4 Replicate GC/MS analysis of NDMA standards and/or sample extracts should be conducted on a daily basis. A precision of $\pm 15\%$ RSD or better should be achieved.

REFERENCES

- (1) Marano, R. S., Updegrove, W. S., and Machem, R. C., "Determination of Trace Levels of Nitrosamines in Air by Gas Chromatography/Low Resolution Mass Spectrometry," *Anal. Chem.*, 54, 1947-1951 (1982).
- (2) Fine, D. H., et. al, "N-Nitrosodimethylamine in Air," *Bull. Env. Cont. Toxicol.*, 15, 739-746 (1976).
- (3) "EPA Method 607 - Nitrosamines," *Federal Register*, 49, 43313-43319, October 26, 1984.
- (4) Anderson, R. J., "Nitrogen-Selective Detection in Gas Chromatography," *Tracor Inc. Applications Note 79-3*, Austin, Texas.
- (5) *Annual Book of ASTM Standards*, Part 11.03, "Atmospheric Analysis," American Society for Testing and Materials, Philadelphia, Pennsylvania.
- (6) Riggin, R. M., "Technical Assistance Document for Sampling and Analysis of Toxic Organic Compounds in Ambient Air," EPA-600/4-83-027, U.S. Environmental Protection Agency, Research Triangle Park, North Carolina, 1983.

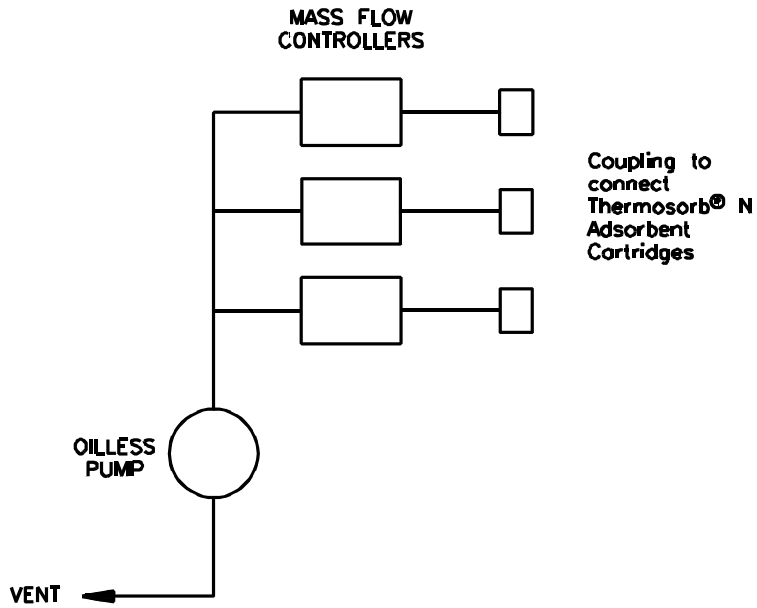

(a) MASS FLOW CONTROL

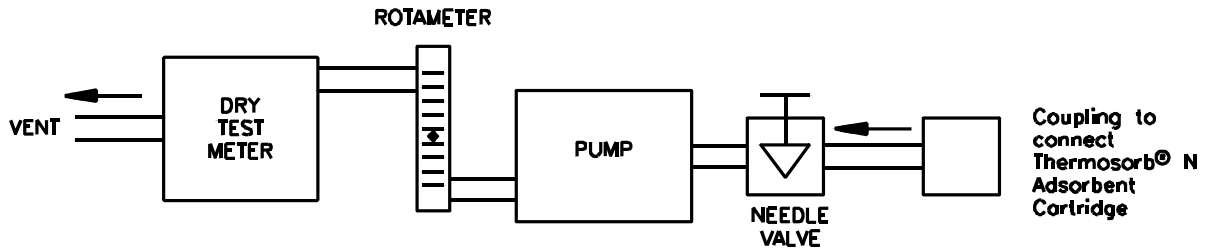

(DRY TEST METER SHOULD NOT BE USED FOR FLOW OF LESS THAN 500 ml/minutes)

(b) NEEDLE VALVE/DRY TEST METER

FIGURE 1. TYPICAL SAMPLING SYSTEM CONFIGURATION

SAMPLING DATA SHEET
(One Sample per Data Sheet)

PROJECT: _____ DATES(S) SAMPLED: _____
 SITE: _____ TIME PERIOD SAMPLED: _____
 LOCATION: _____ OPERATOR: _____
 INSTRUMENT MODEL NO: _____ CALIBRATED BY: _____
 PUMP SERIAL NO: _____

SAMPLING DATA

Sample Number: _____

Start Time: _____

Stop Time: _____

Time	Dry Gas Meter Reading	Rotameter Reading	Flow Rate, *Q mL/min	Ambient Temperature °C	Barometric Pressure, mm Hg	Relative Humidity, %	Comments
1.							
2.							
3.							
4.							
N.							

Total Volume Data**

$$V_m = (\text{Final} - \text{Initial}) \text{ Dry Gas Meter Reading, or} = \text{_____ L}$$

$$= \frac{Q_1 + Q_2 + Q_3 \dots Q_N}{N} \times \frac{1}{1000 \times (\text{Sampling Time in Minutes})} = \text{_____ L}$$

* Flow rate from rotameter or soap bubble calibrator (specify which).

** Use data from dry gas meter if available.

FIGURE 2. EXAMPLE SAMPLING DATA SHEET

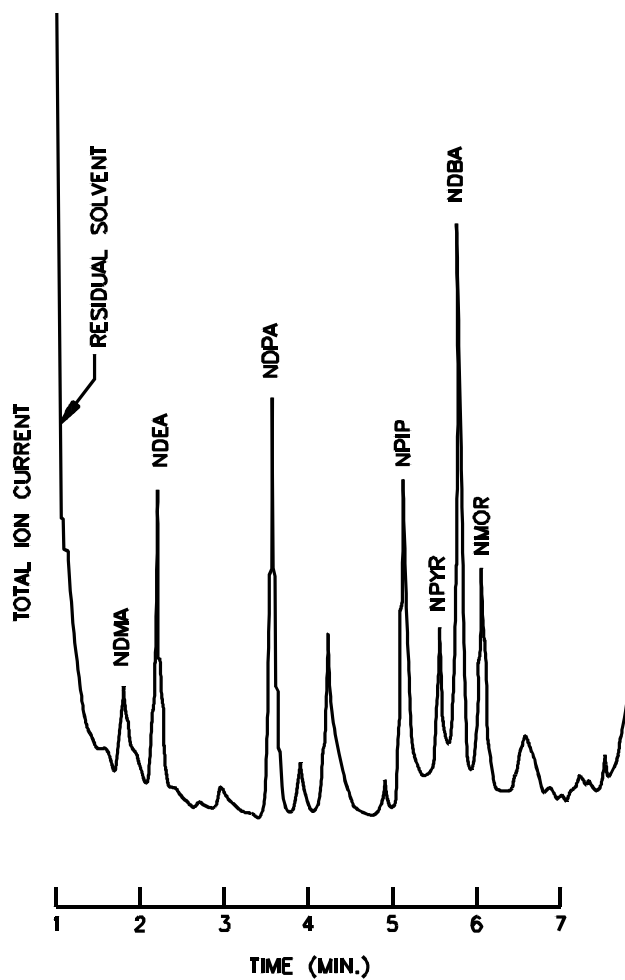
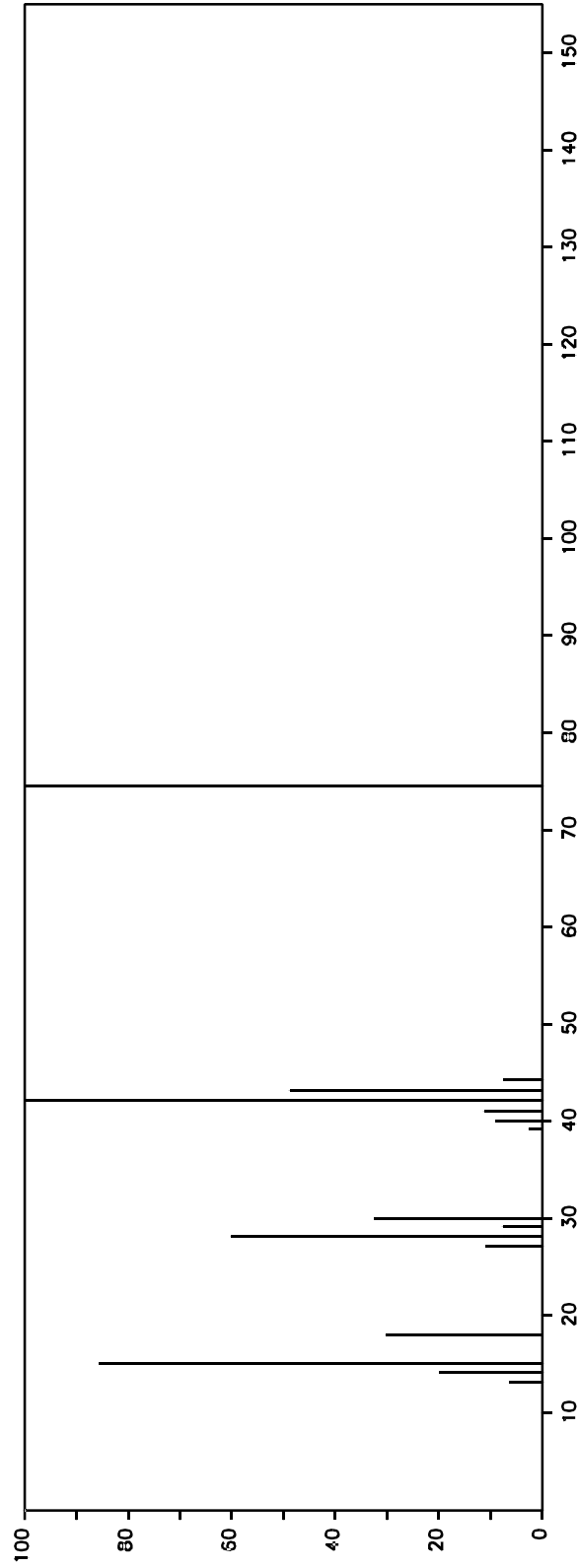

FIGURE 3. TOTAL ION CURRENT CHROMATOGRAM RESULTING FROM INJECTION OF 15 μL SAMPLE OF NDMA STANDARD (10 $\text{NG}/\mu\text{L}$ IN ETHANOL).

$C_2H_6N_2O$
Methanamine, N-methyl-N-nitroso-

Me₂NNO



T07-17

**FIGURE 4. MASS SPECTROSCOPY SCAN (10 TO 150 AMV)
OF NDMA AT A RATE OF 0.5 TO 0.8 SCANS/SECOND**

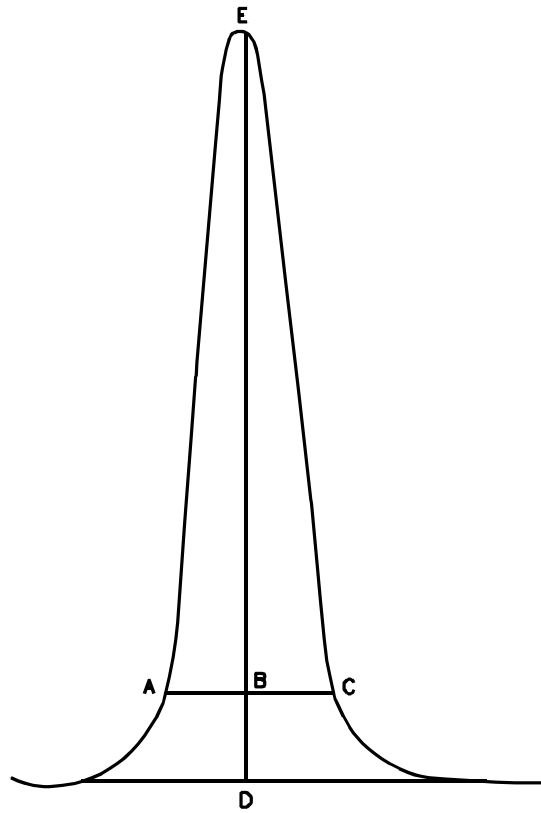

$$\text{Asymmetry Factor} = \frac{BC}{AB}$$

Example Calculation:

Peak Height = DE = 100mm

10% Peak Height = BD = 10mm

Peak Width at 10% Peak Height = AC = 23mm

AB = 11mm

BC = 12mm

$$\text{Therefore: Asymmetry Factor} = \frac{12}{11} = 1.1$$

FIGURE 5. PEAK ASYMMETRY CALCULATION

TABLE 1: SUGGESTED PERFORMANCE CRITERIA FOR RELATIVE ION ABUNDANCES FROM FC-43 MASS CALIBRATION

M/E	% Relative Abundance
51	1.8 ± 0.5
69	100
100	12.0 ± 1.5
119	12.0 ± 1.5
131	35.0 ± 3.5
169	3.0 ± 0.4
219	24.0 ± 2.5
264	3.7 ± 0.4
314	0.25 ± 0.1