

United States
Environmental
Protection Agency

Office of Ground Water
and Drinking Water (4601)

EPA/816-R-99-014p
September 1999



The Class V Underground Injection Control Study

Volume 16

Aquifer Remediation Wells

Table of Contents

	Page
1. Summary	1
2. Introduction	2
3. Prevalence of Wells	4
3.1 States Where Relatively Large Numbers of Aquifer Remediation Wells Exist	8
3.2 States That Reported No ARWs	8
4. Injectate Characteristics and Injection Practices	8
4.1 Injectate Characteristics	9
4.1.1 Remediation Agents	9
4.1.2 Treated Water	25
4.1.3 Freshwater	25
4.2 Well Characteristics and Operational Practices	30
4.2.1 Pump-and-Treat Systems	31
4.2.2 In Situ Bioremediation	31
4.2.3 In Situ Flushing	32
4.2.4 In Situ Chemical Treatment	32
4.2.5 Air Sparging	32
4.2.6 Steam Injection	40
4.2.7 Permeable Treatment Barrier Systems	40
4.2.8 Experimental Wells	42
5. Potential and Documented Damage to USDWs	42
5.1 Injectate Constituent Properties	50
5.2 Impacts on USDWs	51
6. Best Management Practices	53
6.1 Selection of Well Construction Materials	53
6.2 Compatibility with Site Conditions	54
6.3 Well Systems	54
6.3.1 Pump-and-Treat Systems	54
6.3.2 Air Sparging	55
6.3.3 Steam Injection	55
6.3.4 Permeable Treatment Barrier Systems	55

Table of Contents (cont'd)

	Page
7. Current Regulatory Requirements	55
7.1 Federal Programs	56
7.1.1 SDWA	56
7.1.2 CERCLA - Superfund Cleanups	57
7.1.3 RCRA Corrective Actions	58
7.1.4 Underground Storage Tank Program	58
7.2 State and Local Programs	59
ATTACHMENT A: State and Local Program Descriptions	60
REFERENCES	72

AQUIFER REMEDIATION WELLS

The U.S. Environmental Protection Agency (USEPA) conducted a study of Class V underground injection wells to develop background information the Agency can use to evaluate the risk that these wells pose to underground sources of drinking water (USDWs) and to determine whether additional federal regulation is warranted. The final report for this study, which is called the Class V Underground Injection Control (UIC) Study, consists of 23 volumes and five supporting appendices. Volume 1 provides an overview of the study methods, the USEPA UIC Program, and general findings. Volumes 2 through 23 present information summaries for each of the 23 categories of wells that were studied (Volume 21 covers 2 well categories). This volume, which is Volume 16, covers Class V aquifer remediation wells.

1. SUMMARY

Aquifer remediation wells (ARWs) are widely used around the country for beneficial uses associated with the control of ground water contamination. These wells may be used for different specific purposes, including to: (1) introduce remediation agents (i.e., chemicals or microorganisms) into contaminated aquifers to neutralize the contamination; (2) increase ground water flow through the contaminant zone in an aquifer to aid in contaminant removal; (3) form hydraulic barriers to contain contaminant plumes; and (4) re-inject treated ground water for aquifer recharge after an onsite pump-and-treat system.

For many reagents and nutrients injected into ARWs, the concentration in the injectate likely exceeds MCLs or HALs because higher concentrations of such reagents and nutrients are needed for them to serve their intended purposes. The data available about these wells are insufficient to establish meaningful comparisons between concentrations of injected reagents or nutrients in ground water monitoring wells, located downgradient from the ARW where they were injected, and the corresponding MCLs or HALs. Based on the information reviewed, it appears that ground water monitoring activities associated with remediation projects typically focus on the contaminants being remediated, rather than on the reagents, nutrients, or other substances injected into the affected aquifer as part of the remedial activity.

The injectate in ARWs is typically (i.e., in the case of the first three purposes mentioned above) directed into a contaminated aquifer where constituents of concern exceed MCLs. On the other hand, re-injection of treated ground water from an onsite pump-and-treat system may occur into a different formation than that which is being remediated, with the objective of recharging the aquifer. In this last case, the receiving formation may be a USDW and the injectate is monitored to ensure that constituents of concern present in the injectate do not exceed MCLs.

One contamination incident associated with an ARW was reported in the state and USEPA Regional survey conducted for this study. The incident occurred at the Hassayampa Landfill Superfund Site in Arizona in 1998. A failure in an automatic cut-off valve in a pump-and-treat system, concurrent with a failure in the treatment unit, resulted in the accidental injection of untreated ground water into a

clean USDW. The extent of the impact on the USDW or to drinking water wells was not reported.

A majority of ARWs appear to be covered under Comprehensive Environmental Response, Compensation, and Liability Act (CERCLA) Cleanups, Resource Conservation and Recovery Act (RCRA) Corrective Actions, or Underground Storage Tank (UST) cleanup actions. As with any remedial measure, they usually require the approval of the appropriate state and/or federal regulatory agencies. There is some concern for voluntary cleanups that are not approved or completed according to standards typical of cleanups with oversight. Limited information from the survey suggests that voluntary cleanups do occur, but little is known about them based on the information available. Nevertheless, in some USEPA Regions, voluntary cleanups are periodically the subject of inspections by state or federal regulatory agencies (Micham, 1999a) and in Ohio, one of the states with the highest number of ARWs, no contamination is known to have occurred as a result of the operation of an ARW (Cadmus, 1999).

The survey results indicated that there are 10,221 documented ARWs located in 39 states and territories. A significant fraction (65 percent) of the total is concentrated in South Carolina (3,409), Texas (1,177), Ohio (1,170), and Kansas (936). As part of this survey, state and USEPA Regional officials estimated that a slightly higher number of wells, 10,756, actually exists. Taking into consideration the fact that a significant number of additional wells were reported as “under construction” at the time of survey (e.g., 2,170 wells in South Carolina alone), the actual total number of wells could be between 12,000 and 14,000. This also suggests a potential future increase in the number of ARWs.

Based on a review of relevant regulations for the states where ARWs are most prevalent and for a limited set of additional states that constitute a broad geographical sample, it was established that individual permits are required for these wells in at least Arizona, California, Kansas, Nevada, Ohio (required for those wells expected to exceed MCLs), and South Carolina, which collectively have approximately one-half of the documented wells. ARWs may be authorized by rule in New Hampshire and Texas. At the federal level, ARWs are subject to the federal UIC standards, and, as indicated, may be additionally regulated under CERCLA Cleanups, RCRA Corrective Actions, and the UST Program.

2. INTRODUCTION

Aquifer remediation can be defined as the implementation of remedial measures to correct deficiencies, improve selected parameters (such as the quality of flow), or to prevent anticipated or possible problems in permeable materials which contain or are capable of containing ground water. The implementation of such measures historically has been in response to problems that have already occurred. During the 1980s, the United States saw an increase in the incidence or, at a minimum, the recognition of ground water contamination. The resulting aquifer remediation programs share certain goals. The main goal is the abatement of contamination, followed by containment of the area of contamination, and lastly, restoration of the aquifer (USEPA, 1987).

Under certain conditions, ground water remediation efforts may sometimes warrant the subsurface injection of fluids. Injection wells may be used to achieve one or more of the goals of an

aquifer remediation program. They may be used to introduce remediation agents (i.e., chemicals or microorganisms) into contaminated aquifers to neutralize the contamination. Aquifer remediation injection wells may also be used to aid in contaminant removal by increasing ground water flow through the contaminant zone; to form hydraulic barriers to contain contaminant plumes; and to re-inject treated ground water (USEPA, 1987).

The definition of Class V underground injection wells contained in the existing underground injection control (UIC) regulations in 40 CFR 146.5(e) does not specifically mention ARWs. However, all injection wells not included in Class I, II, III, or IV are defined as Class V wells. Class V ARWs are distinguished from Class IV wells, which dispose of hazardous or radioactive waste into or above a formation which contains a underground source of drinking water (USDW) within one-quarter mile (see 40 CFR §144.6(d)). Although Class IV wells are generally prohibited, they are allowed if they are used to inject contaminated ground water that has been treated and is being re-injected into the same formation from which it was drawn, if approved by USEPA pursuant to the provisions for cleanup of releases under CERCLA or RCRA (see 40 CFR §144.13(c)). A well that meets this definition qualifies as a Class IV well, not a Class V ARW.

In support of this study, USEPA conducted a survey of the state and regional staff that administer the UIC programs to collect information on ARWs and other types of Class V wells (Cadmus, 1999). The questionnaire used to gather data defined “ARWs” as wells that are “used to clean up, treat, or prevent contamination of USDWs. Treated ground water (pump-and-treat), bioremediation agents, or other recovery enhancement materials may be injected into the subsurface via Class V wells. These wells may be associated with RCRA or CERCLA projects.” As indicated earlier, ARWs may also be associated with leaking UST site cleanups, voluntary cleanups, or with cleanups regulated under specific state programs. While the UIC programs regulate the ARW itself, the cleanup level associated with the remediation project is generally established by another regulatory program.

ARWs include relatively sophisticated designs in which holes are drilled and cased with metal or plastic pipe. They also include simple systems designed to drain fluids to the subsurface. For example, an improved sinkhole, defined as a surface depression altered to direct fluids into the opening (USEPA, 1987), qualifies as an injection well, as does an abandoned drinking water well that has been adapted to convey fluids to the subsurface. If improved sinkholes or abandoned drinking water wells are used to help clean up contaminated ground water, either by injecting solutions to neutralize contamination or to return previously contaminated ground water that has been treated, they qualify as ARWs. Depending on the system design, some infiltration systems¹ may meet the definition of a Class V injection well. According to available UIC guidance on this matter, each of the vertical pipes in such a system, individually or in a series, should be considered an injection well subject to UIC authorities.

¹“Infiltration galleries” consisting of one or more vertical pipes leading to a horizontal, perforated pipe laid within a trench, often backfilled with gravel or some other permeable material are commonly used to return treated ground water at aquifer remediation sites.

Conventional aquifer remediation technologies have been based on “pump-and-treat” systems. In these systems, the contaminated water is extracted through a well or system of wells to the surface for treatment. The treated water can be re-injected into the subsurface and a cyclical process of water circulation can continue until the contamination level within the aquifer decreases to an acceptable level. “Pump-and-treat” systems have been widely and successfully used for aquifer remediation at numerous sites. However, these systems have been proven to be ineffective and/or considerably more expensive than non-conventional systems under certain conditions, as discussed in Section 4.2.1.

Non-conventional (or alternative) remediation technologies are increasingly being used in stead of conventional “pump-and-treat” systems. Since the early 1990s, innovative technologies have been widely used in decontaminating soil and ground water aquifer at more than 66 percent of the sites with leaking USTs (NRC, 1997). Innovative technologies that typically involve well injection include :

- C In situ bioremediation
- C in situ oxidation
- C in situ flushing
- C air sparging
- C steam injection
- C permeable active barrier systems.

3. PREVALENCE OF WELLS

For this study, data on the number of Class V ARWs were collected through a survey of state and USEPA Regional UIC Programs. The survey methods are summarized in Section 4 of Volume 1 of the Class V Study. Table 1 lists the numbers of Class V ARWs in each state, as determined from this survey. The table includes the documented number and estimated number of wells in each state, along with the source and basis for any estimate, when noted by the survey respondents. If a state is not listed in Table 1, it means that the UIC Program responsible for that state indicated in its survey response that it did not have any Class V ARWs.

A total of 33,872 documented ARWs were initially estimated nationwide by that survey. However, one state - Wyoming - accounted for over two thirds of all the wells based on the survey’s data. As part of the preparation of this report, the Wyoming data, as well as the data for a number of other states, were verified directly with the states or USEPA Regional UIC Programs. In the case of Wyoming, the number reported in the survey has been revised to eliminate many non-ARWs incorrectly assigned as ARWs (Lucht, 1999a). The data presented in Table 1 for Wyoming include one well permitted as a water intrusion barrier well that is used to form a hydraulic barrier to contain a contaminant plume, as discussed in Section 4.1.3. An additional apparent problem associated with the data obtained in the survey on ARWs lies in the

Table 1. Inventory of ARWs in the U.S.

State	Documented Number of Wells	Estimated Number of Wells	
		Number	Source of Estimate and Methodology ¹
USEPA Region 1			
ME	13	50 - 60	Best professional judgment.
NH	64	64	N/A
RI	18	18	N/A
VT	Unknown	10	Best professional judgment.
USEPA Region 2			
NY	30 per RCRA permits (NYSDEC)	100 (NYSDEC)	1998 survey of permits for RCRA facilities.
VI	0	50	Number of Superfund sites with a ground water component.
USEPA Region 3			
DC	25	25	Total estimated number counts the documented number when the estimate is NR.
DE	4	4	N/A
MD	8 facilities	> 17	4 facilities utilize infiltration galleries. One facility has 6 injection wells and another has five wells.
WV	46	46	N/A
USEPA Region 4			
AL	87*	87*	N/A [5 experimental ARWs at the site of Utilities Board of City of Bay Minette (ADEM, 1998)]
FL	25 (1997 UIC inventory) 4-5 sites (Southwest District DEP)	100 - 250	N/A
GA	457	457	N/A
NC	103*	103*	N/A [21 experimental ARWs (NCDENR, 1999)]
SC	3,409	3,409	3,409 active wells at 189 sites; 2,170 wells under construction at 145 sites (Devlin, 1999a).
USEPA Region 5			
IL	150	150	Suspects that more wells exist in IL than documented. Total estimated number counts the documented number when the estimate is NR.

State	Documented Number of Wells	Estimated Number of Wells	
		Number	Source of Estimate and Methodology ¹
IN	5	5	Total estimated number counts the documented number when the estimate is NR.
MI	107 (MI) 382 (Regional)	382	USEPA Region 5 (Micham, 1999b). Total estimated number counts the documented number when the estimate is NR.
MN	11	100	Based on state records and discussion with state officials.
USEPA Region 5 (cont'd)			
OH	1,170	1,170	Ohio EPA has conducted extensive outreach activities to consultants and industry and believes that most of the ARWs have been reported and inventoried. Some additional wells may exist since other state agencies involved in remediation (especially leaking underground storage tank remediation) do not consistently advise owners/operators of the UIC requirements.
WI	36	> 36	Best professional judgment.
USEPA Region 6			
LA	17	17	N/A
NM	83	83	83 active; 5 under construction; 224 temporarily abandoned; and 2 permanently abandoned.
OK	284	284	N/A
TX	1,177	1,177	TXNRCC (Eyster, 1999a).
USEPA Region 7			
IA	50	50	N/A
KS	936	> 936	KDHE Bureau of Water (Cochran, 1999).
NE	40	40	N/A
USEPA Region 8			
CO	94* sites	94* sites	N/A [38 experimental ARWs at 3 sites (USGS, 1996; SECOR, 1999; PEC, 1998)]
SD	623	623	N/A
UT	227	> 227	Some sites may have multiple wells. Inventory forms received in FY1998 are not reflected in the documented number because of an anticipated change in data systems. An additional 22 wells are under construction.

State	Documented Number of Wells	Estimated Number of Wells	
		Number	Source of Estimate and Methodology ¹
WY	11	12	22 existing wells; 11 active; the remaining wells were plugged and abandoned (Lucht, 1999a). Includes one well permitted as a water intrusion barrier well that is used to form a hydraulic barrier to contain a contaminant plume.
USEPA Region 9			
AZ	20	20	Suspects more wells exist in AZ than documented. Total estimated number counts the documented number when the estimate is NR.
CA	131	131	N/A
NV	197	197	N/A
USEPA Region 10			
AK	5	> 5	Best professional judgement. Many more wells than those documented are suspected to exist in AK (Williams, 1999).
ID	27	27	N/A
OR	36	70	Calvin Terada, USEPA Region 10, per telephone conversation with state personnel.
WA	220*	220*	1 experimental ARW at Fort Lewis Logistics Center, Fort Lewis (Pierce County).
All USEPA Regions			
All States	10,221*	10,756*	

¹ Unless otherwise noted, the best professional judgement is that of the state or USEPA Regional staff completing the survey questionnaire.

N/A Not available

Unknown Questionnaire completed, but number of wells is unknown.

* Inventory includes experimental ARWs.

fact that, at least in some cases, monitoring wells installed and operated as part of an aquifer remediation project may have been incorrectly reported as injection wells. For example, the number of ARWs reported in Arkansas was 964, but upon verification, it was established that the state's UIC program does not have any record of ARWs as part of its UIC program and that all the previously reported wells were actually monitoring or recovery wells at RCRA sites (Allen, 1999). As shown, the revised total number of documented ARWs nationwide is 10,221. However, as discussed in Section 3.1, the actual number of ARWs in the U.S. is assumed to be much higher than the survey estimate. In addition, it is estimated that the number of active ARWs may increase in the near future because new remediation projects are being started at a faster pace than the existing projects are being closed.

3.1 States Where Relatively Large Numbers of ARWs Exist

Approximately 65 percent of all the documented ARWs were reported in only four states, including 3,409 wells in South Carolina, 1,177 wells in Texas, 1,170 wells in Ohio, and 936 wells in Kansas. Eight other states (California, Georgia, Illinois, Nevada, Oklahoma, South Dakota, Utah, and Washington) reported between 100 and 900 documented ARWs, with a total number equivalent to approximately 22 percent of the national total. In one case, the survey respondents (South Carolina) provided information about an additional 2,170 ARWs which were under construction (Devlin, 1999a).

In several states, the actual number of ARWs is expected to be considerably higher than the reported number because a large number of wells are known to exist but are regulated by programs different from the UIC program (e.g., wells associated with cleanup of leaking underground storage tanks, Superfund cleanup, RCRA corrective actions, and voluntary cleanups). Some states reported the number of sites where ARWs are known to exist, but did not specify the actual number of wells, which can be expected to be much higher. For example, the state of Colorado reported 91 sites with ARWs. According to the USEPA's 1987 Report to Congress on Class V Injection Wells (USEPA, 1987), of the 81 such wells that existed in Colorado, all of them were located at a single site (i.e., the Rocky Mountain Arsenal). Based on this information, it is reasonable to assume that the actual number of ARWs in the U.S. is higher than reported in the survey.

3.2 States That Reported No ARWs

According to the survey, seven states and a tribal program reported no ARWs (Cadmus, 1999). Those states are located primarily in the eastern and southeastern part of the U.S. and include the following: Connecticut, Massachusetts, New Jersey, Puerto Rico, Pennsylvania, Virginia, Kentucky, Mississippi, and Hawaii. The same sources for uncertainty discussed in Section 3.1 may be applicable to states that reported the complete absence of this type of well.

4. INJECTATE CHARACTERISTICS AND INJECTION PRACTICES

This chapter provides an overview of the injectate and well characteristics of aquifer remediation practices. Section 4.1 summarizes the characteristics of remediation reagents and re-injected treated water that are injected into the ARWs. Section 4.2 discusses well systems and operational issues for aquifer remediation technologies that have been commonly adopted. It is recognized that aquifer remediation is an emerging field and innovative technologies are being developed rapidly. Information regarding alternative aquifer remediation technologies may be obtained through other sources, such as the Vendor Information System for Innovative Treatment Technologies (VISITT) database.² It is not the

² The VISITT database was developed by the USEPA Office of Solid Waste and Emergency Response to promote the use of innovative treatment technologies in the cleanup of soil and ground water contaminated by hazardous and petroleum waste. The database contains information on the technologies

intention of this report to be inclusive of aquifer remediation technologies and systems.

4.1 Injectate Characteristics

The characteristics of the injectate associated with ARWs depends on the intended use of the well. ARWs may be used for a variety of purposes, including:

- C introducing remediation agents (i.e., chemicals or microorganisms) into contaminated aquifers to neutralize the contamination
- C aiding in contaminant removal by increasing ground water flow through the contaminant zone
- C forming hydraulic barriers to contain contaminant plumes
- C re-injecting treated ground water.

Section 4.1.1 describes the various remediation agents associated with applications such as in situ bioremediation, in situ flushing, in situ oxidation, air sparging, steam injection, and permeable reactive systems. Section 4.1.2 presents information about re-injected treated ground water. Section 4.1.3 describes the use of freshwater injection to create a hydraulic barrier to prevent migration of a contaminant plume. The information on remediation agents as described in Section 4.1.1 is based on a limited review of published literature, papers released by the regulatory agencies, vendor literature, and information provided by the reviewers of the draft of this document. In this section, information on remediation agents is summarized in tabular form. In many cases, information regarding the empirical experiments or applications of these remediation agents is also presented in the same tables in order to provide the reader with a comprehensive view of such applications and thus minimize repetition of information throughout the report. The injectate data for treated water presented in Section 4.1.2 was obtained from various agencies. The reference to the hydraulic barrier application presented in Section 4.1.3 were obtained from the survey of state and USEPA Regional UIC Programs (Cadmus, 1999).

4.1.1 Remediation Agents

Bioremediation Agents

Bioremediation is a remediation technology that can take two forms: bioaugmentation and biostimulation. Bioaugmentation involves introducing non-native soil microbes into the contaminated aquifer. Biostimulation attempts to stimulate existing soil microorganisms with reagents to enhance their natural capacity to degrade contaminants (Piotrowski, 1992).

designed to remediate ground water or nonaqueous phase liquids (NAPL) in situ, soil, sludge, solid-matrix waste, natural sediments, and off-gas. The availability, performance, and cost of innovative technologies are provided in the database. The information in the database is submitted voluntarily by technology vendors to market their capabilities and enables federal, state, and private sector environmental professionals to screen innovative technologies for application to specific sites (USEPA, 1997d).

Bioaugmentation involves selecting bacterial strains to degrade specific contaminants. The microbes selected for remediation can be enhanced prior to injection by enrichment culturing. Enrichment culturing involves continually increasing the levels of contaminants that microbes are exposed to during culturing (Sims et al., 1992). A few field studies have been conducted with recombinant bacteria genetically engineered in the laboratory to degrade specific contaminants (USEPA, 1996c).

Biostimulation can be used more readily than bioaugmentation for larger contamination sites because nutrients can be dispersed more easily than microbes throughout the contaminant zone (Piotrowski, 1992). Nutrients injected to stimulate microorganisms may consist of inorganic phosphates, nitrogen in the form of ammonia (NH_4), and micronutrients (e.g., potassium, iron, sulfur, magnesium, calcium, and sodium) (Scalzi, 1992). The types of reagents used to create aerobic and anaerobic degradative environments are different. Oxygen, in the form of sparged air, hydrogen peroxide, or oxygen releasing compounds (ORCs), is necessary to stimulate aerobic biodegradation. Air sparging can create dissolved oxygen concentrations in the ground water as high as 8 to 10 mg/l. Hydrogen peroxide can supply oxygen at concentrations as high as 1,000 mg/l and not impair microbial degradation. Anaerobic microorganisms can be stimulated with reagents such as methane gas, toluene, acetate, lactate, and even molasses (NRC, 1994). Examples of bioremediation applications including the characteristics of injected fluids are shown in Table 2. Several examples of proprietary nutrient compounds used to stimulate microorganisms are shown in Table 3.

In Situ Flushing Agents

In situ flushing agents may be added to pump-and-treat injection well systems to enhance contaminant removal. The types of agents that are introduced into the subsurface by injection include co-solvents, surfactants, sugars, acids, and nutrients. These agents are cycled through an injection and extraction system and enhance contaminant removal through various physical processes. Table 4 provides examples of flushing agents and contaminants that can be used to remediate ground water.

Table 2. Examples of Bioremediation Applications

Remediation Agents	Pollutants	Well type	Site & Scale	Reference
<p>⊆ 5.4 kg (dry weight) <i>Methylosinus trichosporium</i> OB3b (strain of methanotrophic bacteria) suspended in 1,800 l of ground water (5.4×10^9 cells/ ml), injected at 3.8 L/min. for 7.9 hrs</p> <p>⊆ Higgins' phosphate solution (at a concentration with a molarity equal to 10 mM),</p> <p>⊆ phenol red (as a tracer, at a concentration with a molality equal to 20 μm)</p>	<p>⊆ trichloroethene (TCE) 425 ppb</p>	<p>⊆ single well at depth 27 m</p>	<p>⊆ Chico Municipal Airport, Chico, CA</p> <p>⊆ Field test (40 days)</p>	<p>Duba, 1996</p>
<p>5 tests with varying concentrations</p> <p>⊆ Acetate: 84-1,000 mg/l (electron donor)</p> <p>⊆ Nitrate: 120-1,400 mg/l (electron acceptor)</p>	<p>⊆ carbon tetrachloride (CCl_4)</p>	<p>⊆ single injection well</p>	<p>⊆ field demonstration, Hanford, WA</p> <p>⊆ 35 days per test</p>	<p>Hooker, 1994</p>
<p>⊆ Toluene: 7 to 13.4 mg/l</p> <p>⊆ mixture of gaseous oxygen & hydrogen peroxide to dissolved oxygen at conc. of 30-40 mg/l, to promote cometabolism of toluene and contaminants by microorganisms</p>	<p>⊆ TCE (0.5 -1.2 mg/l)</p>	<p>⊆ 2 injection wells 10 m apart</p>	<p>⊆ 410 day demonstration project at Edwards AFB, CA</p> <p>⊆ 22-meter sq. treatment zone, 60-m. wide ground water plume</p>	<p>McCarty, 1997</p> <p>McCarty, 1998</p>
<p>⊆ 1%-4% methane in air, pulsed injection</p> <p>⊆ 0.07% nitrous oxide and 0.007% tri-ethyl phosphate in air, continuously injected</p> <p>⊆ gaseous nutrient injection achieved better mass transfer than liquid nutrient injection</p>	<p>⊆ TCE</p> <p>⊆ PCE (tetrachloro-ethylene)</p>	<p>⊆ injection via a horizontal well in the contaminated aquifer</p> <p>⊆ extraction via parallel horizontal well in vadose zone</p>	<p>⊆ full scale demonstration, Savannah River Site, GA</p>	<p>Hazen, 1993</p> <p>U.S. DOE, 1995</p>

Table 2. Examples of Bioremediation Applications (cont'd)

Remediation Agents	Pollutants	Well type	Site & Scale	Reference
<p> C Methane research grade (99% purity) supplied in four 350-ft³ cylinders at levels between 1% and 1.8% v/v of injected air flow C air, injection rate varied from 1.5 cfm to 5 cfm C vapor-phase nutrients (if needed) C injected to stimulate methanotrophs to degrade methane and in doing so, produce an enzyme(MMO), a non-specific oxidizer, which degrades TCE </p>	<p>C TCE</p>	<p> C one 2-inch (diameter) air injection well screened just below ground water (39-41.5 feet) C one 4-inch (diameter) soil venting well, screened in the vadose zone and connected to soil venting blowers (to contain injected gasses and remove vapors through contaminated soil and water) </p>	<p> C CTMI test Nov. 2, 1994 - Feb. 17, 1995 </p>	<p>Sutfin & Ramey, 1997</p>
<p> C Sodium benzoate C Sodium lactate C Methanol C reagents recirculated in ground water at 1.5 gal/min. for a total of about 250,000 gal. (equals 2 pore volumes) during the pilot study C agents used to enhance anaerobic bacteria degradation </p>	<p>C 100-400 ppm chlorinated VOC's</p>	<p> C 3- 8 ft. deep gravel filled infiltration trenches C 2- 240 ft. long horizontal wells with 30 ft. screened intervals (horizontal wells at 16 and 26 ft. depths) </p>	<p> C Pinellas Science, Technology, and Research Ctr., Largo FL (former DOE site) C Pilot demonstration area 45 ft. x 45 ft. x 30 ft. C Feb. - Jun. 1997 </p>	<p>Hightower, 1998 Sewell, 1998</p>
<p> nutrient mix ratio: 100:10:1 (carbon: nitrogen: phosphorus) C Ammonium chloride C Sodium dibasic phosphate C Sodium monobasic phosphate substrate mix: C Sodium acetate (1,860 kg) C Sodium benzoate(2,163 kg) Added to both mixes C Sodium bromide (151 kg) or 1,000 mg/l </p>			<p>C Gulf Coast manufacturing site, anaerobic in situ bioremediation, 400 days</p>	<p>Leethem, 1995</p>

Table 2. Examples of Bioremediation Applications (cont'd)

Remediation Agents	Pollutants	Well type	Site & Scale	Reference
<p>∮ testing different methods to stimulate native anaerobic bacteria</p> <p>∮ test lane: metal rods carrying electric current generating hydrogen ions on the rods which microbes use to degrade contaminants</p> <p>∮ several test lanes of various nutrients and additives including yeast extract and vitamin B₁₂</p> <p>∮ the nutrients (including yeast extract and vitamin B₁₂) were added in various concentrations and at different depths.</p>	<p>∮ PCE</p> <p>∮ TCE</p>		<p>∮ Fallon Naval Air Station, Nevada. Test site was a fire training pit, test area is 20 ft. deep, 25 ft. long and has 5 treatment lanes (each 10 ft. wide, and separated by high density polyethylene sheet pile), ground water is 8-10 ft. below surface</p>	<p>Civil Engineering, 1998</p>
<p>∮ Vitamin B₁₂</p> <p>∮ Titanium citrate is added to reduce the central cobalt atom in B₁₂</p> <p>∮ both of these reagents are acceptable food additives</p> <p>∮ this biochemical system does not stimulate bacteria, rather it causes in situ reductive dechlorination.</p>	<p>∮ PCE</p> <p>∮ TCA</p> <p>∮ DNAPLs (dense non-aqueous phase liquids)</p>	<p>∮ patented in situ vertical circulation column</p>	<p>∮ series of in situ column experiments</p> <p>∮ University of Waterloo, Canada</p>	<p>Lesage et al., 1996</p> <p>Millar et al., 1997</p>
<p>∮ Vitamin B₁₂</p> <p>∮ Titanium citrate is added to reduce the central cobalt atom in B₁₂</p>	<p>∮ TCE</p> <p>∮ DNAPLs</p>	<p>∮ patented in situ vertical circulation column</p>	<p>∮ series of in situ column experiments</p>	<p>Sorel et al., 1998</p>

Table 2. Examples of Bioremediation Applications (cont'd)

Remediation Agents	Pollutants	Well type	Site & Scale	Reference
<p>⊘ Molasses, injection of this carbohydrate solution which is mostly sucrose, is degraded by heterotrophic microorganisms. The degradation depletes the dissolved oxygen in the ground water creating a reductive environment</p> <p>⊘ Carbon source (dilute molasses) periodically pumped into the center of the contaminant plume</p> <p>⊘ With in one month, strong reducing conditions existed after heterotrophic microorganisms depleted soluble oxygen in ground water</p> <p>⊘ Reduction can occur:</p> <ul style="list-style-type: none"> < by microbial processes involving species such as <i>Bacillus subtilis</i> < by extra cellular reaction with by-products of sulfate reduction such as H₂S < Or by biotic oxidation of the organic compounds including the soil organic matter such as humic and fulvic acids 	<p>⊘ Hexavalent Chromium (< 15 ppm)</p>	<p>⊘ 3 injection and 5 five monitoring wells</p>	<p>⊘ Field demonstration at a Midwest industrial facility</p>	<p>Nyer, 1996</p>

Table 3. Examples of Proprietary Nutrient Compounds for Bioremediation Applications

Manufacturer	Product Name	Nutrients	Contaminants	Source
Medina Agricultural Products Co., Inc. P.O. Box 390, Highway 90 West Hondo, Texas 78861 (830)-426-3011	<i>Medina Bio-D</i>	One gallon weighs (10 lbs.) & contains the following: C 95,367 mg Ammonia-N C 95,367 mg Nitrate-N C 626,466 mg Organic-N C 121,425 mg Ortho Phosphate C 79,450 mg Potassium C 136,200 mg Humic Material		Correspondence with manufacturer
Medina Agricultural Products Co., Inc. P.O. Box 390, Highway 90 West Hondo, Texas 78861	<i>Medina Microbial Activator</i>	One gallon weighs 8.75 lbs. & contains following: C 4,782 mg Magnesium C 1,392 mg Iron(+2) C 1,210 mg Zinc C 2,361 mg Sulfate C 14,710 mg Chloride		Correspondence with manufacturer
Horner & Co. 26197 Carmelo Street Carmel, CA 93923 (831)-620-0544	<i>MaxBac</i>	consists of a (resin coated) granule containing: C Ammonium nitrate C Phosphorus C trace inorganic nutrients C vitamins the complete structure is referred to as a <i>Prill</i> and is manufactured in two release profiles (3-4 months and 6-7 months) depending upon resin coating C concentrations used depends upon naturally present soil nutrients(nitrate-nitrogen, ammonium-nitrogen, & ortho-phosphate)	Organic wastes: gasoline, diesel fuel, crude oil, pesticides, creosote, and pentachlorophenol	Manufacturer literature

Table 3. Examples of Proprietary Nutrient Compounds for Bioremediation Applications (cont'd)

Manufacturer	Product Name	Nutrients	Contaminants	Source
Ecology Technologies International, Inc.	<i>FyreZyne</i> C nontoxic by USEPA recommended test for marine vertebrate and invertebrate forms, and non toxic by ingestion or inhalation in various organisms.	C FyreZyne (multifactoral aqueous liquid) source of : C Bacterial growth agents C Extracellular enzymes C Bioemulsifiers/surfactants which are biodegradable C can be diluted 4, 5, and 6% for bioremediation enhancing agent	Petroleum, partially oxidized contaminants	Manufacturer literature

Table 4. Examples of Flushing Agents and Their Application

Flushing Agents	Contaminants Targeted
Clean Water	High solubility organics; soluble inorganic salts
Surfactants	Low solubility organics; petroleum products
Water/Surfactants	Medium solubility organics
Co-solvents	Hydrophobic contaminants
Acids	Basic organic contaminants, metals
Bases	Phenolics, metals
Reductants/Oxidants	Metals

Source: RTDF, 1997

Nonaqueous phase liquids (NAPLs), which include dense nonaqueous phase liquids and light nonaqueous phase liquids (LNAPLs), are not removed effectively with conventional pump-and-treat remediation technologies. Injecting co-solvents (water plus a miscible organic solvent) into contaminated ground water aids in dissolving both DNAPLs and LNAPLs. Co-solvents can be effective in remediating NAPLs by increasing contaminant solubility in ground water. Once the co-solvent has begun to solubilize the contaminant, ground water can be pumped to the surface for further treatment. Co-solvent remediation agents can be used alone or in conjunction with surfactants. See Table 5 for examples of co-solvent applications.

Surfactants (surface-active-agents) work in much the same manner as co-solvents. Surfactants increase the solubility and/or mobility of NAPLs. However, unlike co-solvents, surfactants work by forming microemulsions of surfactant micelles that surround contaminant molecules, as well as decreasing the interfacial tension and capillary forces binding contaminants to porous aquifer materials. Thus, by increasing the solubility of the NAPLs, surfactants enhance pump-and-treat technology and allow for extraction of the contaminant in ground water. Most surfactants under investigation are used in detergents and food products. It is not uncommon to investigate more than 100 surfactants before selecting a remediation agent for a project (CH2MHill, 1997; Jafvert, 1996). This study did not identify documentation of actual full scale demonstrations of this technology, but numerous pilot demonstrations are under way or have already been completed. See Table 6 for examples of surfactant applications.

In situ flushing systems can also inject sugars, acids, and nutrients as remediation agents. The cycling of reagents through the aquifer provides enhanced dispersal in the contaminant zone. Extracted ground water can be analyzed and amended with additional reagents when necessary. For example, nutrient levels must be monitored and amended to ensure optimal microbial activity to ensure degradation levels of contaminants. See Table 7 for examples of in situ flushing application using sugars, acids and nutrients.

Table 5. Examples of In Situ Flushing (Co-solvent Remediation) Applications

Remediation Agents	Pollutants	Well type	Site & Scale	Reference
<ul style="list-style-type: none"> ☐ 70% ethanol ☐ 12% n-pentanol ☐ 28% water ☐ 40, 000 L of mixture used over 15 days 	☐ NAPL		<ul style="list-style-type: none"> ☐ Hill AFB, Utah ☐ Test 1 OPU 1 ☐ 3 m. x 5 m. test cell 30 ft. deep ☐ 1994-1995 	Jafvert, 1996
<ul style="list-style-type: none"> ☐ either tert-butanol or isopropanol mixed with n-hexanol ☐ 5,000-7,000 gallons of alcohol mixture 	☐ NAPL (60 gallons)		<ul style="list-style-type: none"> ☐ Hill AFB, UTAH ☐ Cell 3, OPU1 test cell ☐ 3 m x m. x 30 ft. deep ☐ summer 1996 	Jafvert, 1996
<ul style="list-style-type: none"> ☐ 1,000 gallons of tert-butanol followed by ☐ 2,000 gallons of tert-butanol/hexanol mixture followed by ☐ 4,000 gallons tert-butanol 	NAPLs: <ul style="list-style-type: none"> ☐ decane ☐ undecane ☐ toluene ☐ 1,1,1 TCA 		<ul style="list-style-type: none"> ☐ Hill AFB, UTAH ☐ Cell 3, OU-1 	RTDF, 1997
<ul style="list-style-type: none"> ☐ Ethanol 	☐ DNAPL ☐ PCE		<ul style="list-style-type: none"> ☐ Dover AFB, Dover Delaware ☐ Test Cell Dover 3 ☐ Pilot/Field Demonstration ☐ Scheduled 	Roote, 1998
<ul style="list-style-type: none"> ☐ washing solution: alcohol = n-butanol surfactant= Hostapur SAS 60® solvent = D-limonene and toluene ☐ preliminary wash with polymer solution 	☐ weathered refinery oil wastes from the 1960s ☐ chlorinated DNAPLs: <ul style="list-style-type: none"> ☐ 1,1,2-TCA ☐ naphtalene 	Cone injection well surrounded by four recovery wells	<ul style="list-style-type: none"> ☐ Thouin San Pit, Quebec, Canada ☐ 4.3 m x 4.3 m test plot (0.075% of contaminated site); 2 m thick silty sand layer 	Martel et al., 1998

* Note: Some co-solvents are used in conjunction with surfactants.

Table 6. Site Examples of In Situ Flushing (Surfactant Remediation) Applications

Remediation Agents	Pollutants	Well type	Site & Scale	Reference
<ul style="list-style-type: none"> ☒ Triton X-100, 400 mg/l at 3 gal/ min. for 30 days 	<ul style="list-style-type: none"> ☒ TCE at 1-5 mg/l 	<ul style="list-style-type: none"> ☒ 3 injection wells 10 ft. apart 	<ul style="list-style-type: none"> ☒ Picatinny Arsenal, NJ ☒ test site (6 months) 	Jafvert, 1996
<ul style="list-style-type: none"> ☒ Dowfax 8390, 60 mM, 540 gallons (3.8 wt %) at an injection rate of 1 gal/min. 	<ul style="list-style-type: none"> ☒ PCE 10 µg/l, jet fuel 	<ul style="list-style-type: none"> ☒ vertical circulation well, (two 5 ft. lengths of stainless steel screen separated by 2 ft. of steel casing) ☒ single borehole well system 	<ul style="list-style-type: none"> ☒ Coast Guard Station, Traverse City Michigan ☒ Field Test, June 1995 	Jafvert, 1996 Knox, 1997
<ul style="list-style-type: none"> ☒ 4.3 wt% Dowfax 8390 ☒ injected 2 PV* of water ☒ then 10 PV of Dowfax solution ☒ followed by 2 PV of water 	<ul style="list-style-type: none"> ☒ LNAPL 		<ul style="list-style-type: none"> ☒ Hill AFB, Utah ☒ Cell 6, OU-1 	RTDF, 1997
<ul style="list-style-type: none"> ☒ 3.6 wt % solution Dowfax 8390 and diphenyloxide disulfonate mixture, same as Traverse City site ☒ 10 PV of surfactant, followed by 5 PV of water 	<ul style="list-style-type: none"> ☒ NAPL 		<ul style="list-style-type: none"> ☒ Hill AFB, Utah ☒ OPU1, Cell 6 ☒ test cell 3 m x 5 m. x 30 ft. ☒ summer 1996 	Jafvert, 1996
<ul style="list-style-type: none"> ☒ Brij 97 (C₁₈EO₂₀) with n-pentanol as a cosurfactant (makes a Winsor Type I single phase microemulsion) ☒ expect to use 2 PV of water, 5-7 PV surfactant/ cosurfactant, 2 PV of surfactant (alone), & 5 PV water (PV = 2,500 gal.) 	<ul style="list-style-type: none"> ☒ NAPL 		<ul style="list-style-type: none"> ☒ Hill AFB, Utah ☒ OPU 1, Cell 8 ☒ test cell 3 m. x 5 m. x 30 ft. ☒ summer 1996 	Jafvert, 1996
<ul style="list-style-type: none"> ☒ 3% Brij 97, 2.5 % n-pentanol by weight in water, 9 PV of Brij 97 & n-pentanol, then 1PV of Brij 97 alone, and finally 6.5 PV of water ☒ produces a low viscosity oil-in-water microemulsion on contact with NAPL ☒ peristaltic pumps maintained a flow rate of 3.6 l/min or 1 pore volume per day (1PV=5,500 l) 	<ul style="list-style-type: none"> ☒ LNAPL (major components) ☒ 1,3,5, tri-methylbenzene ☒ undecane ☒ decane 	<ul style="list-style-type: none"> ☒ 15 multilevel samplers, 3 extraction wells and 4 injection wells. Injection and extraction wells were screened from 4.9 m to 7.9 m below ground surface with 0.25 mm slotted stainless steel casing. 	<ul style="list-style-type: none"> ☒ Hill AFB, Utah, OU1 ☒ sand and gravel aquifer material ☒ 2.8 m x 4.6 m test cell which penetrated into the clay aquitard 3.7 m. ☒ sheet pile enclosed test cell ☒ July-August 1996 	Rhue et al., 1998

Table 6. Site Examples of In Situ Flushing (Surfactant Remediation) Applications (cont'd)

Remediation Agents	Pollutants	Well type	Site & Scale	Reference
<ul style="list-style-type: none"> ☐ an Aerosol OT/ Tween series surfactant mixture, with added CaCl₂ 	<ul style="list-style-type: none"> ☐ NAPL 		<ul style="list-style-type: none"> ☐ Hill AFB, Utah ☐ Cell 5, OPU1, ☐ test cell 3 m. x 5 m x 30 ft. ☐ summer 1996 	Jafvert, 1996
<ul style="list-style-type: none"> ☐ 8% Aerosol MA (Sodium dihexyl sulfosuccinate) and 4% isopropyl co-solvent, injected 2.5 PV 	<ul style="list-style-type: none"> ☐ DNAPL ☐ 1,1,1, TCA ☐ TCE ☐ PCE 		<ul style="list-style-type: none"> ☐ Hill AFB, Utah ☐ OU2 	RTDF, 1997
<ul style="list-style-type: none"> ☐ 4% Aerosol MA ☐ 11,500 ppm NaCl ☐ air (added to the solution to create a foam that could control mobility) ☐ simultaneously inject air and 3.5 PV of surfactant solution ☐ cannot use alcohol with this system because it degrade foam 	<ul style="list-style-type: none"> ☐ DNAPL ☐ TCE 		<ul style="list-style-type: none"> ☐ Hill AFB, Utah ☐ OU2 ☐ April 1997 work completed 	RTDF, 1997
<ul style="list-style-type: none"> ☐ 4 wt% Aerosol MA ☐ Co-solvent 4 wt% isopropyl alcohol ☐ 2 wt% 1:1 NaCl and CaCl₂ 	<ul style="list-style-type: none"> ☐ DNAPLs ☐ TCE ☐ some PCBs and other chlorinated solvents 		<ul style="list-style-type: none"> ☐ DOE Gaseous Diffusion Site ☐ Portsmouth, Ohio ☐ Pilot/Field Demonstration ☐ completed 	Roote, 1998
<ul style="list-style-type: none"> ☐ 0.5 wt% Na₂CO₃ ☐ 1.1 wt% NaHCO₃ ☐ 0.5 wt% Na₂O(SiO₂)_{3.22} ☐ 0.01 wt% Chloramine T plus 1,000 mg/l ☐ xanthan gum 	<ul style="list-style-type: none"> ☐ Hydraulic oil ☐ LNAPL 		<ul style="list-style-type: none"> ☐ Hialeah County, Florida ☐ Pilot/Field Demonstration ☐ former industrial site ☐ completed 	Roote, 1998
<ul style="list-style-type: none"> ☐ Sorbitan monooleate (U.S. FDA food-grade additive) 	<ul style="list-style-type: none"> ☐ DNAPL(TCE) 		<ul style="list-style-type: none"> ☐ U.S. DOE Gaseous Diffusion Plant, Paducah, Kentucky ☐ pilot/field demonstration site 	Roote, 1998

* PV = pore volume

Table 7. Examples of In Situ Flushing (Sugars, Acids and Nutrients) Applications

Remediation Agents	Pollutants	Site & Scale	Reference
<p>(Sugars) C Cyclodextrin (beta cyclodextrin) C 10 pore volumes of 10% cyclodextrin</p>	<p>C 1,1,1-TCA C o-xylene C decane C undecane</p>	<p>C Hill AFB, Layton Utah C OU-1 Cell 4</p>	<p>RTDF, 1997</p>
<p>C Complexing sugar (macromolecular solubilization)</p>	<p>C DNAPL (PCE)</p>	<p>Dover AFB, Dover, Delaware C scheduled Pilot/Field Demonstration</p>	<p>Roote, 1998</p>
<p>(Acids) C Citric Acid (originally used at the site) C Now a proprietary compound is used.</p>	<p>C Arsenic</p>	<p>C Gulf Power Co, Lynn Haven Florida C Full Scale/ Commercial site</p>	<p>Roote, 1998</p>
<p>(Nutrients) C Nutrients (organic fertilizers) dissolved in treated site ground water</p>	<p>C PCP C PAHs C LNAPL (diesel fuel 5%PCP)</p>	<p>C Montana Pole & Treating, Butte Montana C Full-scale/Commercial C in progress</p>	<p>Roote, 1998</p>

In Situ Chemical Treatment

In situ chemical treatment may be accomplished with reaction such as oxidation or reduction. In situ oxidation involves the injection of reagents to stimulate degradative chemical reactions with the contaminants in the ground water. For example, in one application, hydrogen peroxide (H_2O_2) is injected with ferrous sulfate to produce hydroxyl radicals. The hydroxyl radicals then oxidize the organic compounds into carbon dioxide, water, and chloride ions (in the case of chlorinated hydrocarbons). In another application, hydrogen peroxide and potassium permanganate ($KMnO_4$) were used at a DOE site in Kansas City to eliminate VOCs, SVOCs, and PCBs in conjunction with soil mixing (Cline et al., 1997). Hydrogen peroxide has been used to treat DNAPLs, although it has only been effective with tetrachloroethylene (PCE) and trichloroethylene (TCE). Oxidation may also be fostered by introducing ORCs. Other in situ oxidants include ozone and chlorine, which are injected into the ground water as a gas. Examples of in situ oxidation applications can be found in Table 8.

Chemical reduction may also be used to remediate ground water contamination. For example, chromium (VI), a toxic and mutagenic form of chromium, may be reduced to chromium (III), which poses a lesser health concern. Iron (II) and iron (0) are traditionally used as reductants and recently calcium polysulfide was proven to be more effective (Sabatini, 1997; Slosky & Company, 1998).

Air Sparging

Air sparging uses wells to inject compressed air into the subsurface to volatilize dissolved contaminants with vapor pressures less than 1 mm Hg (USEPA, 1994). This technology focuses on contaminants that can be evaporated when exposed to increased air flow. Air sparging can also be used to stimulate aerobic microorganisms present in the subsurface environment by providing oxygen, by injecting either air or pure oxygen. Oxygen levels in the ground water can reach 8 to 10 mg/l if air is injected and as high as 40 mg/l if pure oxygen is injected (Piotrowski 1992). This type of system, may also be referred to as forced air injection, in situ aeration, or biosparging (depending, among other things, on the specific characteristics of the application).

Steam Injection

Steam injection is sometimes used to remove organic contaminants from ground water and soil. Pilot tests and full-scale applications have used steam injection to remove heavy fuel oils (No.2 diesel fuel to No.6 fuel oil, with vapor pressures >1.0 mm Hg) and to aid in vapor extraction and separate phase pumping (Dablow et al., 1995). Steam is injected into the subsurface through injection wells to stimulate volatilization of the contaminants. The high temperatures of the steam alter the phase of the contaminants into recoverable forms (a vapor phase, a separate liquid phase, and a dissolved aqueous phase). Steam also physically displaces the various phases of the contaminants and aids in surface recovery for further treatment. Steam injection can be effective in cases where viscous forces cannot be used to remove volatile or

Table 8. Examples of In Situ Chemical Treatment Applications

Remediation Agents	Pollutants	Well type	Site & Scale	Reference
<ul style="list-style-type: none"> ☐ Hydrogen peroxide(H₂O₂) 4,200 gallons incrementally injected ☐ Ferrous sulfate 	<ul style="list-style-type: none"> ☐ DNAPL (593 lbs.) ☐ TCE, PCE 		<ul style="list-style-type: none"> ☐ Full scale demonstration ☐ Savannah River Site, Aiken, SC ☐ (64,000 cubic foot site) 	Jerome, 1997 Cline et al., 1997
<ul style="list-style-type: none"> ☐ solution of acidified ferrous sulfate heptahydrate (FeSO₄ ☐ 7H₂O) ☐ 566 lbs. Fe⁺² ☐ 867 lbs. HCl ☐ 1,628 lbs. NaOH 	<ul style="list-style-type: none"> ☐ Hexavalent Chromium ☐ 75,000-100,000 gallons contaminated water 	<ul style="list-style-type: none"> ☐ 1,700 yd³ overlaying soil excavated to a depth of approx. 8ft. ☐ series of injection wells and trellises 	<ul style="list-style-type: none"> ☐ Perched aquifer 10-12ft. Below grade(aquifer with geology isolating it from other aquifers or water) 	Environmental Engineering, 1995
<ul style="list-style-type: none"> ☐ Potassium permanganate (KMNO₄) 	<ul style="list-style-type: none"> ☐ pure phase TCE 		<ul style="list-style-type: none"> ☐ Portsmouth Gaseous Diffusion Plant ☐ DOE's Subsurface Contaminant Focus Area (SCFA) 	Jerome, 1997 Cline et al., 1997
<ul style="list-style-type: none"> ☐ Hydrous pyrolysis / oxidation 	<ul style="list-style-type: none"> ☐ DNAPLs ☐ dissolved organic components 		<ul style="list-style-type: none"> ☐ Commercial wood treatment facility in CA ☐ DOE's SCFA 	Jerome, 1997
<ul style="list-style-type: none"> ☐ Chlorine dioxide (ClO₂) ☐ Treated 650 m³/day of ground water with oxidant concentration of 72 mg/l ☐ Used ClO₂ because potassium permanganate and hydrogen peroxide didn't have enough oxidation capability. 	<ul style="list-style-type: none"> ☐ Petroleum concentrations as high as 1.0 mg/l ☐ Over 80 organic pollutants ☐ Pollution not detected below 40m. of water table 	<ul style="list-style-type: none"> ☐ injection well 480 mm diameter, 200 m. deep. ☐ generator produced 2kg/h of mixed gases mainly of ClO₂ with small amounts of Cl₂, O₃ and H₂O₂ ☐ gases dissolved into circulating fresh water and injected at 106 m through a spray head. 	<ul style="list-style-type: none"> ☐ Zibo, China ☐ Pilot study (9 days) ☐ Karst aquifer 75-150m. below ground surface ☐ Water table at test site 26 m. below land surface 	Zhu et al., 1998

Table 8. Examples of In Situ Chemical Treatment Applications (cont'd)

Remediation Agents	Pollutants	Well type	Site & Scale	Reference
<p>ORC (oxygen release compound) C proprietary formulation of magnesium peroxide C ORC reacts with water to form a suspension of magnesium hydroxide C magnesium hydroxide is common Milk of Magnesia. <i>Regensis Bioremediation Products, San Juan Capistrano, CA</i></p>				<p>Manufacturer literature Chapman, 1997 Morin, 1997</p>
<p>Geo-Cleanse Process proprietary method and equipment which injects C hydrogen peroxide, aqueous solution ferrous sulfate C trace quantities of metallic salts a catalyst formulation <i>Geo-Cleanse, Ramsey, NJ</i></p>	<p>C Common organics including: C chlorinated hydrocarbons (including ethenes, ethanes, and DNAPLs) C BTEX C fuel oil C aromatic solvents C plasticizers C coal tar, C pesticides C PCB's</p>	<p>C patented methodology and equipment using patented mixing heads which deliver reagents under pressure via specially designed wells.</p>		<p>Manufacturer literature</p>
<p>C Vitamin B₁₂ C Titanium citrate is added to reduce the central cobalt atom in B₁₂ C both of these reagents are acceptable food additives C this biochemical system does not stimulate bacteria, rather is causes in situ reductive dechlorination.</p>	<p>C PCE, TCA C DNPALs C TCE, C DNAPLs</p>	<p>C patented in situ vertical circulation column</p>	<p>C series of in situ column experiments</p>	<p>Lesage et al., 1996 Millar et al., 1997 Sorel et al., 1998</p>

semi-volatile contaminants trapped in the subsurface (Davis, 1998a). Table 9 provides examples of applications of this remediation technology.

Permeable Reactive Treatment Systems

In some cases, the dimensions of treatment barriers are such that they meet the definition of an injection well. Permeable reactive treatment barriers are usually constructed downstream of a contaminant plume and reactive zones can be located throughout a contaminant plume or downstream of it. Contaminants become immobilized or degraded as ground water naturally flows through the wall or zone. Physical, chemical, and/or biological processes can be involved in remediating the contaminants. These processes can include: precipitation, sorption, oxidation/ reduction, fixation, or degradation. Treatment walls can be constructed of various compounds such as: metal-based catalysts, chelating agents, nutrients, slurry, and oxygen release compound (Vidic and Prohland, 1996). Examples of permeable treatment barrier systems can be found in Table 10.

4.1.2 Treated water

As indicated earlier, pump-and-treat systems have been applied extensively and successfully to aquifer remediation. Different onsite treatment technologies may be used as part of these systems, depending on the characteristics of the contaminants of concern, as well as onsite characteristics. Obviously, the composition of the re-injected treated ground water varies from site to site. As a result, a comprehensive discussion regarding the characteristics of the re-injected treated water is beyond the scope of this document. As an example, Table 11 presents data for the influent and effluent (i.e., the injectate) from the operation of an air stripping system at the U.S. Department of the Army's Pueblo Depot Activity in Pueblo, Colorado (USDOD, 1998). The data show that the concentrations of contaminants of concern found in the contaminated aquifer are consistently reduced to levels below primary drinking water quality standards in the effluent of the treatment system, which is then re-injected.

The South Carolina Department of Health & Environmental Control (SCDHEC) reported the results of injectate monitoring at a site where ground water hydrocarbon contamination was being treated using a pump-and-treat system that consisted of air strippers and activated carbon units. For all monitoring events during the period between November 1997 and September 1998, the quality of the injectate was consistently below the permit discharge limits (Devlin, 1999a). Table 12 summarizes the monitoring results; for simplicity, the table presents the range of influent and effluent concentrations over the period indicated.

4.1.3 Freshwater

As discussed in Section 2, one of the purposes of ARW is the formation of hydraulic barriers to contain contaminant plumes. This study did not identify documentation of hydraulic barrier applications permitted as ARWs. However, an example of such an application was identified, although it was permitted as a different type of well.

Table 9. Examples of Steam Injection Applications

Remediation Agents	Pollutants	Well type	Site & Scale	Effectiveness	Reference
<p>⊆ steam 270 million pounds, 171-182°C</p>	<p>⊆ creosote</p>	<p>⊆ 11 injection wells surrounding the free-phase creosote (80-100 ft. deep) ⊆ recovery through 7 centrally located extraction wells</p>	<p>Southern California's Edison's Visalia, CA Pole Yard, field scale operation</p>	<p>80,000 gallons recovered or destroyed since starting in May 1997</p>	<p>Davis, 1998b</p>
<p>⊆ air and/or steam is injected through the hollow kellys while augers drill</p>	<p>⊆ 500-5,000 ppm VOC's below a shallow water table <2 ft. below ground surface</p>	<p>⊆ dual auger 35 ft. long, with hollow kelly bars with 5 ft. diameter augers, 48 wells drilled</p>	<p>⊆ field scale operation (3 month) ⊆ treatment of 2,000 cubic yards of saturated soil and ground water</p>	<p>1,200 lbs. VOC's removed from soil and ground water, contaminant. levels reduced 70-80 %</p>	<p>Hightower, 1998</p>
<p>⊆ steam ⊆ pressure at wellheads varied from 3,500-14,000 kg/m² with a steam temp. of 120 °C ⊆ steam flowrates at 7,200 kg/h were required during initial heating ⊆ Once soil reached 100°C, the flowrate to maintain the temp was 3,600 kg/h</p>	<p>⊆ diesel fuel between 190,000 and 400,000 L</p>		<p>⊆ Huntington Beach, California ⊆ ruptured product delivery pipeline polluted a sand lens 12-13 meter deep (interbedded fine to medium sand, silt and minor clays) as well as a perched water to a depth of 13 feet</p>	<p>⊆ After 22 months, approx. 113,000 L of diesel fuel was removed (98% recovery)</p>	<p>Dablow et al., 1995</p>

Table 10. Examples of Permeable Treatment Barrier Systems

Remediation Agents	Pollutants	Reactive Wall Type	Site & Scale	Reference
<ul style="list-style-type: none"> ∩ ORC (oxygen release compound) 54 kg of sand and ORC mixture placed in each treatment well, for a total of 378kg 	<ul style="list-style-type: none"> BTEX 	<ul style="list-style-type: none"> ∩ 7 wells 20 cm. diameter PVC wire wrapped treatment wells 0.6 meters on center, ∩ total depth of 6.1 m. with 1.5 m. screen extending on both well ends. 	<ul style="list-style-type: none"> ∩ former gasoline storage site ∩ Ontario, Canada 	<ul style="list-style-type: none"> Chapman et al., 1997
<ul style="list-style-type: none"> ∩ ORC used to stimulate aerobic biodegradation ∩ treatment ratio of 3 pounds of oxygen to 1 pound of GRO and BTEX. ∩ Total of approximately 1,000 lbs. ORC used 	<ul style="list-style-type: none"> ∩ BTEX conc. of 48 mg/l ∩ GRO conc. up to 170 mg/l 	<ul style="list-style-type: none"> ∩ treatment “fence” consisting of 15 borings spaced 10 feet apart ∩ Each boring contained 90 lbs. of 65% solids ORC slurry. Each boring was 4 5/8 inches in diameter and to an approx. depth of 10 ft. below the water table 	<ul style="list-style-type: none"> ∩ southwestern Washington State ∩ retail gasoline station 	<ul style="list-style-type: none"> Morin, 1997

**Table 11. UIC Report – Pueblo Depot Activity, Pueblo, Colorado
(April through June, 1998)**

Influent Concentrations							
Analyte	4/2/98	4/14/98	5/5/98	5/20/98	6/03/98	6/16/98	MCL
1,1-dichloroethene	ND	0.00060	0.00086	0.00077	0.00067	0.00053	0.007
1,2- dichloroethene (cis)	0.033	0.030	0.036	0.034	0.031	0.027	0.070
1,2- dichloroethene (trans)	ND	ND	0.00036	0.00036	0.00033	0.00034	0.0001
Trichloroethene	0.055	0.050	0.056	0.055	0.048	0.041	0.005
Total Chromium	0.0081	0.013	0.0082	0.0074	0.0091	0.0085	0.1
Effluent = Injectate Concentrations							
Analyte	4/2/98	4/14/98	5/5/98	5/20/98	6/03/98	6/16/98	MCL
1,1-dichloroethene	ND	ND	ND	ND	ND	ND	0.007
1,2- dichloroethene (cis)	0.0034	0.0037	0.0028	0.0028	0.0032	0.0038	0.0070
1,2- dichloroethene (trans)	ND	ND	ND	ND	ND	ND	0.001
Trichloroethene	0.0026	0.0028	0.0017	0.0018	0.0020	0.0025	0.005
Total Chromium	0.0083	0.010	0.0082	0.0074	0.0090	0.0080	0.1

All concentrations in mg/l.

ND: non detect

Source: U.S. DOD, 1998.

**Table 12. SCDHEC, UIC Permit #149M - SCRDI
Bluff Road Ground Water Treatment System
(System Effluent Report - November 97 through September, 1998)**

Analyte	Permit Discharge Limit	Treatment system influent	Treatment system effluent = Injectate
Acetone	1.100	BDL – 0.073	BDL
Benzene	0.005	BDL – 0.009	BDL
Carbon tetrachloride	0.005	0.037 – 0.100	BDL
Chlorobenzene	0.100	BDL – 0.004	BDL
Chloroform	0.021	0.310 – 0.760	BDL – 0.001
1,1-Dichloroethane	0.005	0.120 – 0.270	BDL
1,2-Dichloroethane	0.005	0.017 – 0.035	BDL
1,1-Dichloroethene	0.007	0.068 – 0.240	BDL
1,2-Dichloroethene (total)	0.070	0.182 – 0.360	BDL
1,2-Dichloropropane	0.005	BDL – 0.0022	BDL
Ethylbenzene	0.700	0.0017 – BDL	BDL
Methylene chloride	0.017	BDL – 0.018	BDL
1,1,2,2-Tetrachloroethane	0.0006	0.033 – 0.072	BDL
Tetrachloroethene	0.005	0.040 – 0.094	BDL
Toluene	2.000	BDL – 0.011	BDL
1,1,1-Trichloroethane	0.200	0.023 – 0.062	BDL
1,1,2-Trichloroethane	0.002	BDL – 0.003	BDL
Trichloroethene	0.005	0.050 – 0.110	BDL
Xylene (total)	10.000	BDL – 0.005	BDL
Total VOCs	--	0.943 – 2.103	BDL – 0.001
Iron	- *	0.914 – 2.710	BDL – 0.012

All concentrations in mg/l

BDL: below detection limit

* Secondary MCL for iron: 0.300 mg/l

Source: South Carolina Dept. of Health & Environmental Control, 1998.

The Petrotonics Freshwater Injection System (PFIS) is used to prevent migration of a plume in Wyoming. The parameter used to characterize the plume was total dissolved solids (TDS) and the plume was caused by uranium tailings facilities. The PFIS is designed to inject freshwater through a buried perforated pipe into the contaminated aquifer creating a freshwater hydraulic barrier. The Land Quality Division of the Wyoming Department of Environmental Quality regulated the PFIS as a salt water intrusion barrier well (Lucht, 1999b).

4.2 Well Characteristics and Operational Practices

The selection, design, construction, and operation of ARWs depend on a wide range of site specific factors, the selected remedial techniques and reagents, and the well system designs. The site specific factors include: for soil -- subsurface geology, hydraulic gradients, intrinsic permeability, soil composition; for water - E_h , pH, suspended solids, and cation (calcium, magnesium, iron, sodium, and potassium) and anion (chloride, sulfate, phosphate and nitrate) concentrations, and reactivity of certain naturally occurring constituents present in the aquifer to the chemicals introduced; and for dissolved contaminant properties -- solubility and vapor pressure (FRTR, 1997). As a result of the wide range of variables that affect the operation of ARWs, it is extremely difficult to generalize the operational practices of the different types of ARWs.

ARWs can be used to inject remediation agents at various depths, pressures, phases and temperatures. For example, bioremediation and in situ oxidation remediation inject reagents directly into the contaminated aquifer. Remediation agents can also be injected below the contaminated aquifer, as can be the case for air sparging.

Temperature can play an important role in the selection of well construction materials for several types of ARWs. For example, in situ oxidation chemical reactions can generate significant amounts of heat that requires using heat resistant well materials. A steam injection well system must also be resistant to heat and pressure.

Clogging is a potential threat to the effectiveness or long term operation of most ARWs. For example, specific cations can precipitate out of solution when exposed to elevated levels of oxygen. Iron precipitation can lead to clogging of air sparging wells and the injection well apparatus. Practices used to prevent precipitation include lowering aquifer pH with acids to keep cations in solution or injecting chelating agents to bind iron. Well systems can also be clogged with excessive biomass, resulting from microbial growth due to biostimulation (Dahab, 1992). Microbiocides can be used to diminish bacterial growth at the well head. Colloid materials have been suggested as possible materials that may clog pump-and-treat systems.

In many applications, nutrients or reagents are not injected continuously, but rather periodically and often the frequency of injection depends on the development of the remediation process. Therefore, in such cases, the frequency of monitoring may be set to be the same as the frequency of nutrient/reagent injection. Maximum permissible concentrations may be established at the downgradient monitoring wells and operation of the injection system may be conditioned to meeting those maximum permissible concentrations. An operational condition may be such that the nutrient/reagent addition program would be reevaluated and appropriate adjustments made to the concentration of the injectate and/or to the frequency of injection if

downgradient monitoring well data indicate that the maximum permissible concentrations have been exceeded (USEPA, 1998b).

As stated earlier, the description of well systems used in aquifer remediation applications presented in this volume is not intended to be all inclusive. Some system designs are shown as examples of the application of conventional and innovative technologies. The omission of other alternative system and designs is not meant to imply that they are not useful or valid systems.

4.2.1 Pump-and-Treat Systems

“Pump-and-treat” is by far the most common technology used in aquifer remediation. The treatment system is composed of four elements: an extraction well or system of wells, a water pumping system, an above ground treatment system, and injection wells. “Pump-and-treat” systems can be used for hydraulic containment of contaminant plumes and/or for the removal of dissolved contaminants from ground water. Wells that extract water create hydraulic containment or capture zones (low hydraulic points to which nearby water will flow). Pressure ridges are formed by the water that is introduced to the subsurface from injection wells, which also cause an increase in water flow/velocity to the extraction wells. The specific numbers of injection and extraction wells are dependent upon the remediation site (USEPA, 1996a). As indicated earlier, “pump-and-treat systems have been widely and successfully used for aquifer remediation at numerous sites. However, pump-and-treat technology has been proven to be ineffective in removing contaminants that:

- C are immiscible in water
- C have diffused into micro pores or zones within the aquifer material not accessible to substantial water flow
- C sorb to subsurface materials
- C exist in heterogeneous subsurface environments.

In addition, a pump-and-treat system requires substantial infrastructure and expenses for installation and operation (NRC, 1997).

4.2.2 In Situ Bioremediation

The delivery of bioremediation agents most often occurs through injection wells, and well construction depends upon the type of agent being used. Bioremediation systems can be pump-and-treat systems that cycle added nutrients or can be in situ systems that inject dissolved agents or gases in to the subsurface. Horizontal and vertical injection wells have been used in bioremediation systems. Soil conditions can greatly affect the levels of nutrients added to a system. Soil composition needs to be taken into account for remediation since calcium, aluminum, iron, and lead can sequester injected nutrients in significant quantities (Scalzi, 1992).

Examples of bioremediation wells that inject methane gas and gaseous nutrients are shown in Figures 1- 3. These figures are for an in situ bioremediation project that used horizontal wells for reagent delivery. The horizontal and vertical sections of these wells were composed of an outer casing of steel with a smaller

diameter steel tube through which injection occurred. The well systems horizontal sections were composed of perforated steel tubing for gas injection and vapor removal.

4.2.3 In Situ Flushing

Pump-and-treat systems sometimes add reagents to the injected water to enhance the efficiency of contaminant removal. In situ flushing improves contaminant removal by increasing contaminant solubilization/emulsion formation and/or chemical reactions in each pore volume extracted. The extraction rate must be larger than the injection rate of the co-solvent/ surfactants to ensure recovery. Wells involved in situ flushing can be vertical, angled, and/or horizontal (Roote, 1997). Figure 4 is an example of the in situ flushing system.

4.2.4 In Situ Chemical Treatment

Injection of oxidative agents for in situ oxidation may require the use of metal as compared to PVC piping due to the heat that can be generated from chemical reactions. An example of a well system used for in situ oxidation is provided in Figure 5. This well system is composed of steel piping of two lengths, both with stainless steel screens at the pipe bottoms allowing for injection of the hydrogen peroxide and ferrous sulfate mixture. The wells are surrounded with grout and contain bentonite seals above each of the stainless steel screens. This system injects the remediation agents under pressure.

4.2.5 Air Sparging

Air sparging systems (also known as forced air injection, in situ aeration, or biosparging) use wells that inject pressurized air into the subsurface to volatilize contaminants that are dissolved in the aquifer. These wells are usually constructed of PVC or stainless steel pipe with diameters of 1 to 5 inches. The screened area of the well where air escapes ranges in length from 1 to 3 feet (screens of longer length do not transport air more efficiently because air usually escapes from the upper portion of the screen). Grouting of the well is essential to prevent leaks and maintain proper system function (USEPA, 1994). Figures 6 and 7 provide examples of air sparging treatment systems.

Vertical injection wells are used for deeper contamination (>25 feet) and in water tables (>10 feet). Horizontal wells can be used for sites that require numerous sparging or extraction wells and at a site with a shallow water table (<25 feet) (USEPA, 1994). The depth of the injection well is usually deeper than the contaminated aquifer to allow for percolation of air upward through the aquifer.

**Figure 1. In Situ Bioremediation Using Horizontal Wells:
Overall System Design**

U.S. Department of Energy; Savannah River Site, South Carolina

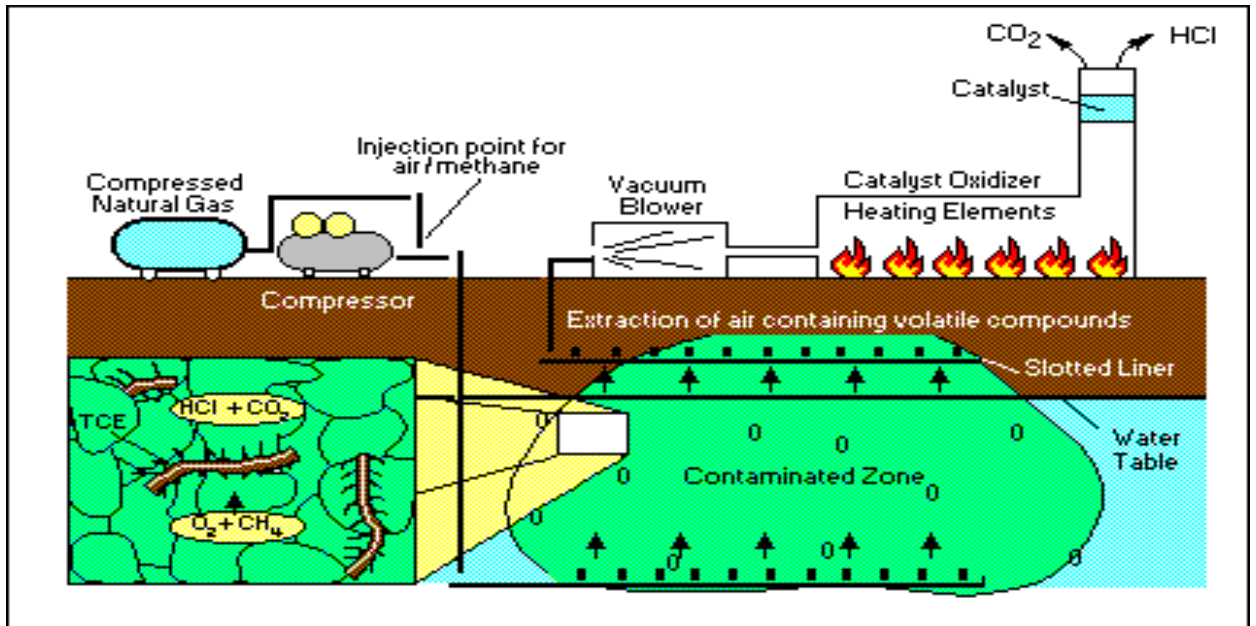

Source: U.S. DOE, 1995

Figure 2. In Situ Bioremediation Using Horizontal Wells: System Configuration

U.S. Department of Energy; Savannah River Site, South Carolina

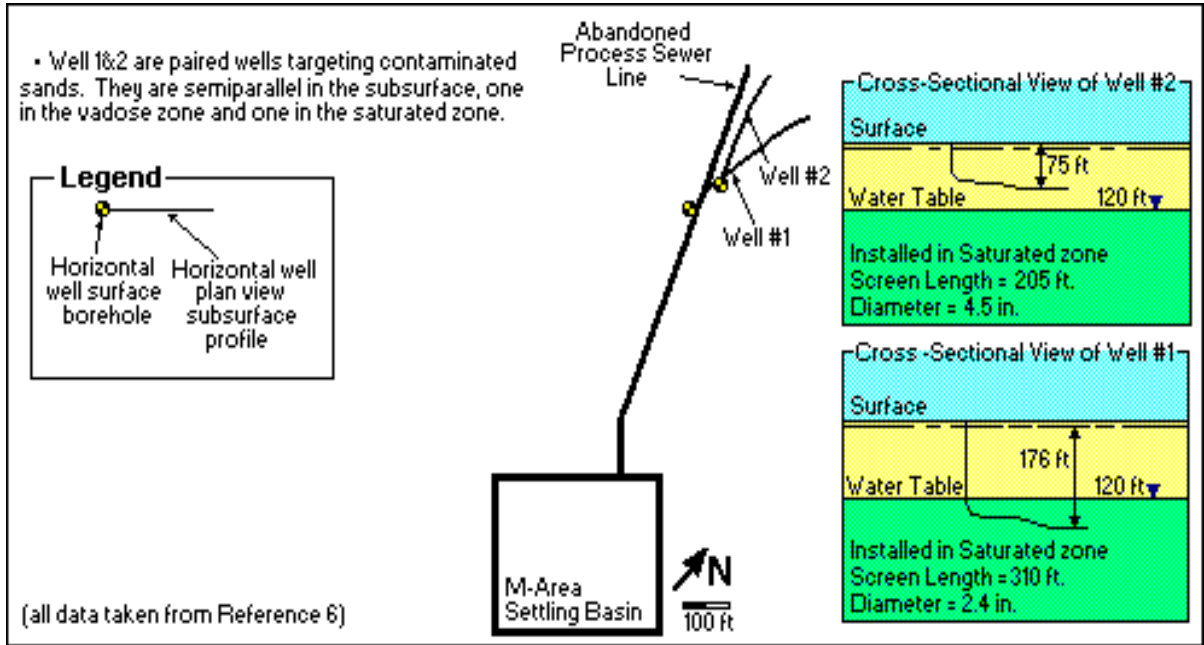

Source: U.S. DOE, 1995

**Figure 3. In Situ Bioremediation Using Horizontal Wells:
Horizontal Wells Close-up**
U.S. Department of Energy; Savannah River Site, South Carolina

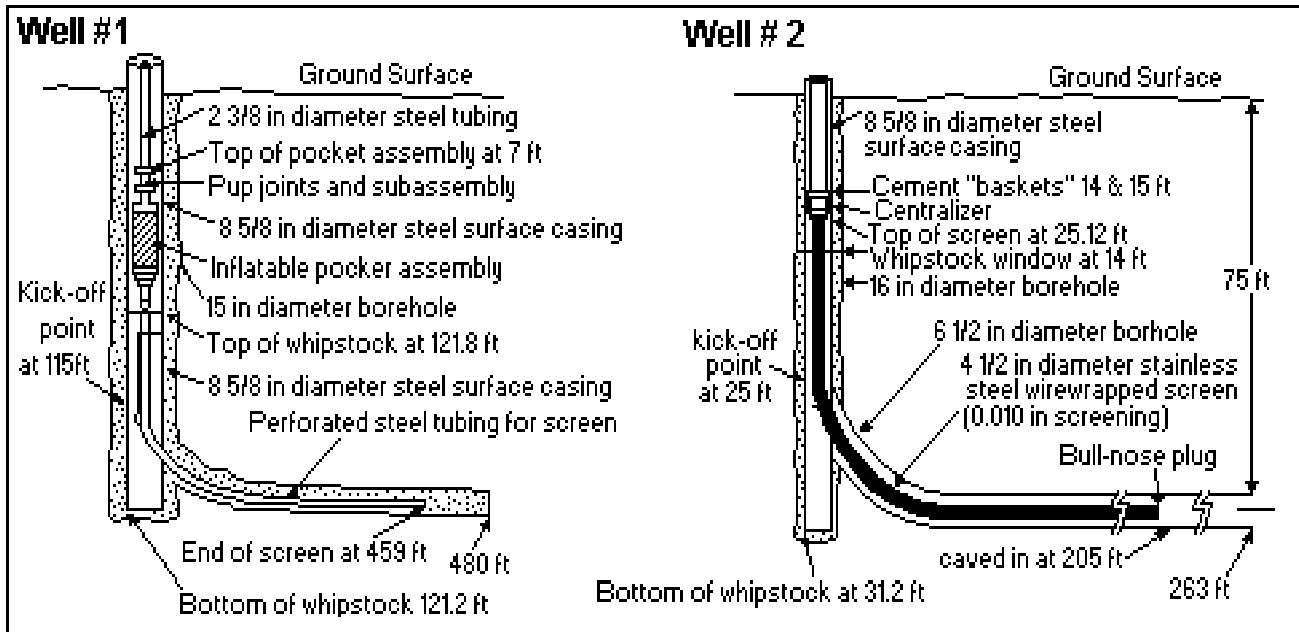

Source: U.S. DOE, 1995

Figure 4. An Example of an In Situ Flushing System

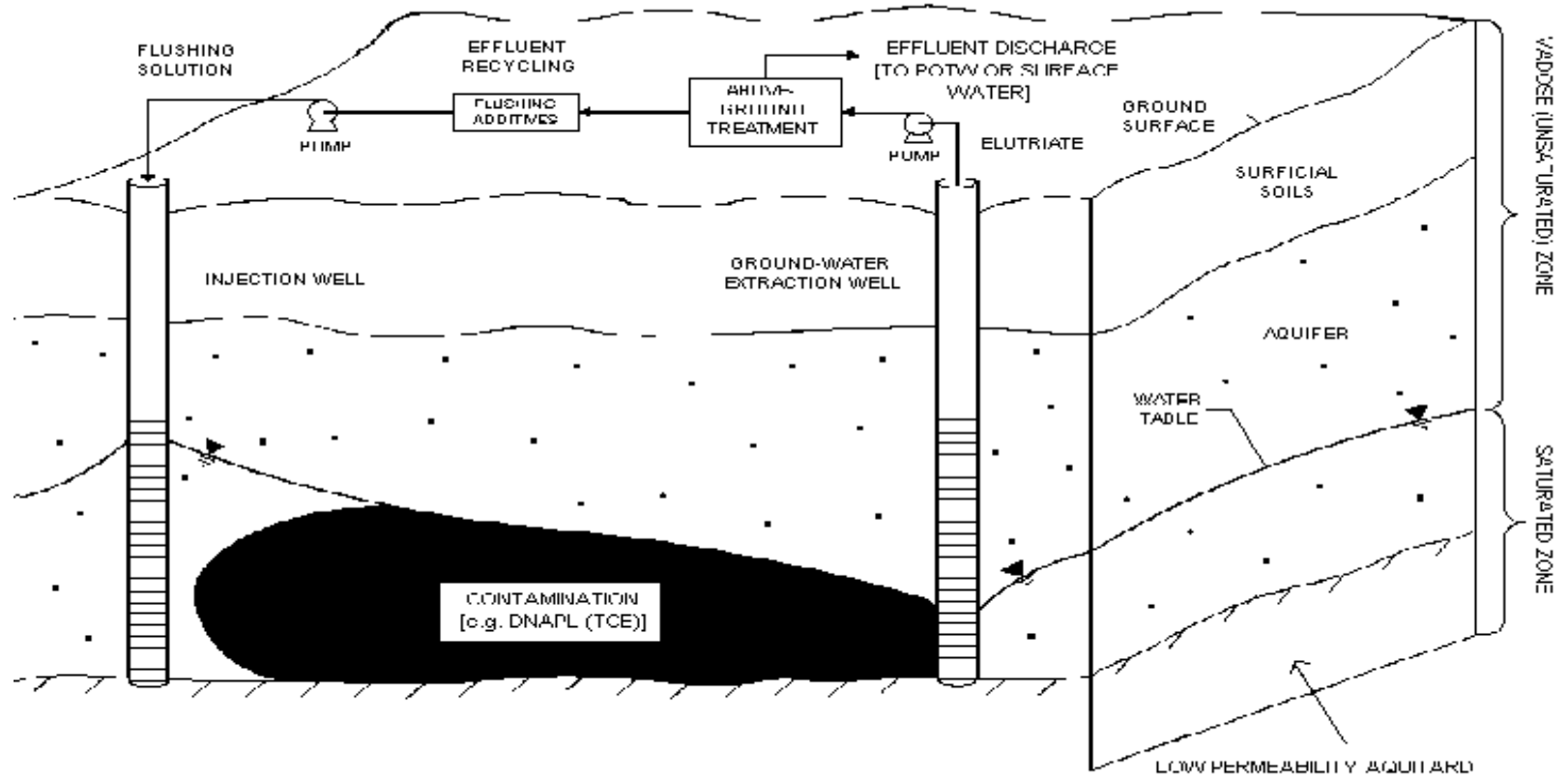

Modified from U.S. EPA (1991) and U.S. Department of Energy (1996).

Source: Roote, 1997

September 30, 1999

**Figure 5. An Example of an In Situ Oxidation Treatment System:
Geo-Cleanse Patented Process Flow Diagram**

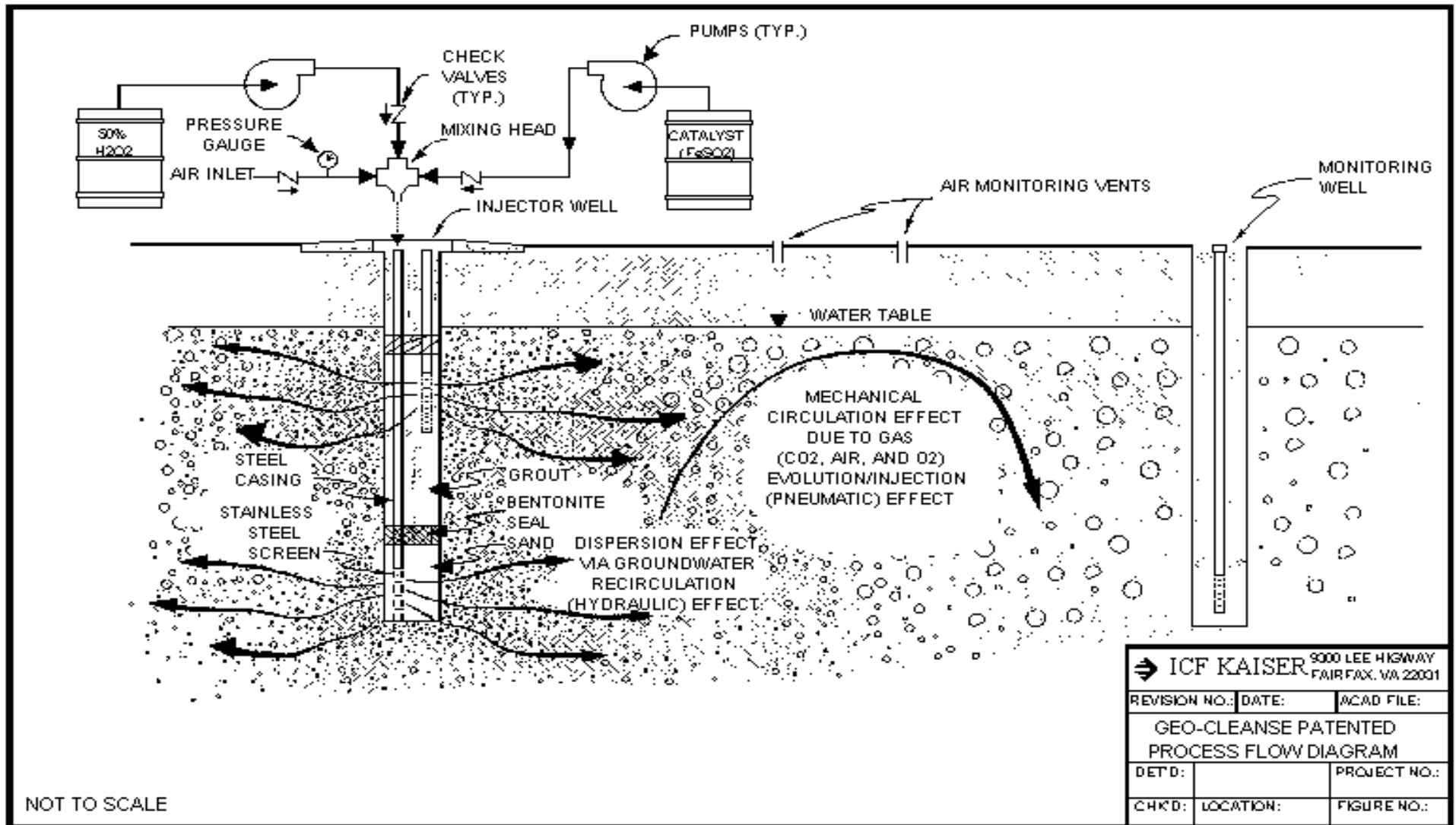
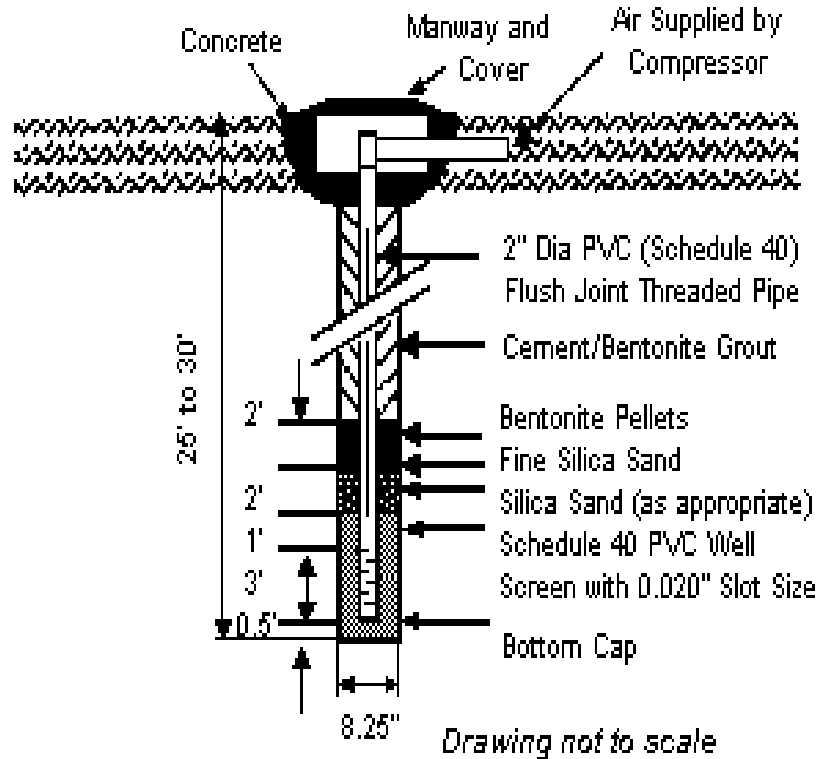

Figure 6. Example of an Air Sparging System

Typical Sparging Well



Note:

- C The in situ sparging system consists of 30 two-inch diameter air sparging wells within a 3-foot long screened section installed into a depth of approximately 25 to 30 feet, two 300 scfm blowers housed within the ground water treatment shed, and buried manifold connecting the blowers and sparging wells.
- C Sparging will be performed at an air flow rate of between 10 and 30 scfm and a pressure of 12 pounds per square inch at each well.

Source: FRTR, 1995

Figure 7. Typical Oxygen Enhanced Bioremediation System For Contaminated Ground Water (Air Sparging/Nutrient Enhancement)

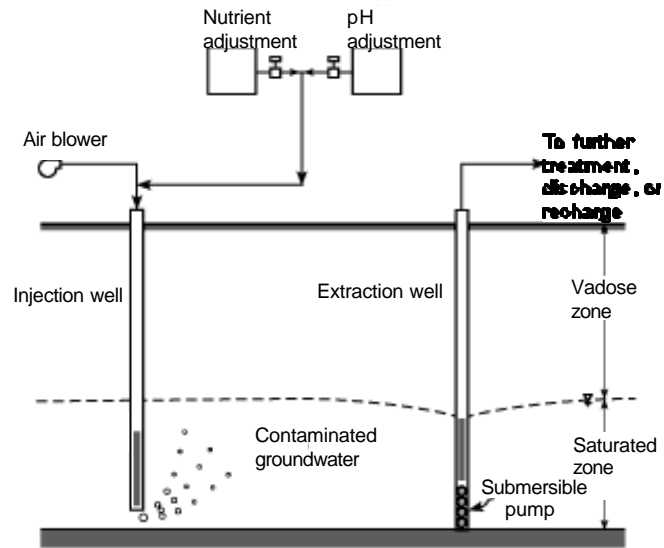

Source: RTDF, 1997

Dissolved minerals in the aquifer being remediated need to be assessed carefully. Dissolved iron can become oxidized from the increased oxygen flow and precipitate as a consequence. Precipitation can become a major problem, and eventually clog injection wells. Air sparging is an appropriate technology to be considered in soil types that have permeabilities which allow circulation of injected air (USEPA, 1994).

4.2.6 Steam Injection

Key elements of an injection system to produce and inject steam include a steam generator, distribution system to the wells, the extraction system, and the collars/condensers for the extracted fluids (Davis 1998a). Steam injection wells are frequently composed of steel casing, rather than PVC and fiberglass which are less resistant to temperature and pressure extremes. Well casing cementing also requires modification for steam injection because conventional well cements will not remain stable under high temperatures. Cements with 30 to 60 percent of quartz silica or silica by weight and sodium chloride are more stable to temperature extremes. Figure 8 presents an example of a steam injection well.

Factors to be taken into account for steam injection systems include steam injection rate, pressure, temperature, and quality.³ Soil fracture pressure can be estimated as 1.65 psi per meter of depth below the surface of the ground.

Equally important is the placement of wells. Well placement, in terms of the distance between injection wells and in overall system configuration, is crucial to system efficiency. A small contaminant area maybe be surrounded by injection wells and have extraction wells in the center of the area. Larger areas of contamination usually require a pattern of injection and extraction wells. Distances of 1.5 meters between wells have been used in pilot studies and spacings up to 18 meters have been used in full scale operations (Davis, 1998a). See Figure 9 for examples of steam injection well placement.

Injection rates are dependent upon the distance between injection wells, the sweep efficiency of injected steam, and the heat losses to over- and under-burden. Continuous steam injection has proven effective in contaminant removal in pilot and full-scale demonstrations (Davis, 1998a).

4.2.7 Permeable Treatment Barrier Systems

Permeable treatment barriers can be installed in several different ways. A trench can be dug downstream from a contaminant plume and backfilled with reactive material. This method can be used for shallow reactive barriers. However, if the length of the trench is greater than its depth, it is not considered a well. For sites with contaminant plumes at greater depths, treatment

³The injection pressure of steam is dependent upon the depth of injection. It is recommended that steam pressure be as high as possible without exceeding the soil overburden pressure such that fracturing occurs.

Figure 8. Steam Injection Well

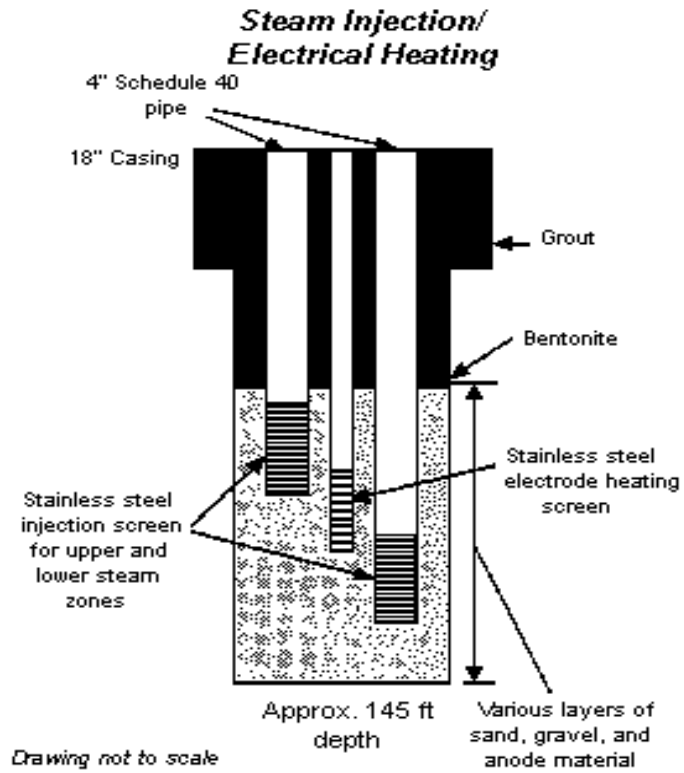

Source: FRTR, 1995

Figure 9. Common Steam Injection Well Patterns

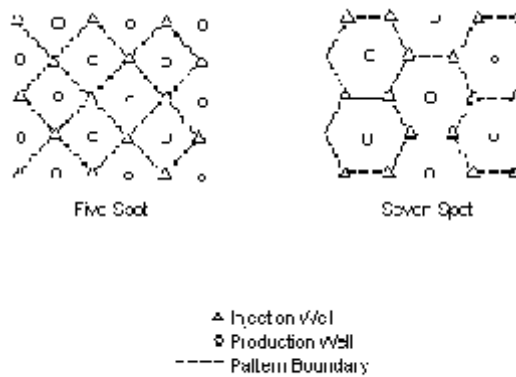

Five spot and seven spot well patterns used for steamflooding

Source: Davis, 1998a

walls require reinforcement with slurry or steel sheet pilings (Vidic and Pohland, 1996). Figure 10 shows an example of the well construction of permeable treatment barriers.

Permeable reactive zones, such as systems that inject ORC into wells in a contaminated area, can be created with a matrix of multiple injection points. The injection wells are basically created with tools used to inject well grout. An example of a reactive zone is presented in Figure 11; such a system may consist of 10 wells, each with a 6 inch diameter and packed with ORC through the contaminant zone. The dynamics of the barrier are governed by the amount of oxygen placed in the wells, in the form of ORC, and the oxygen release rate.

Based on information from the states of Texas (Eyster, 1999b) and South Carolina (Devlin, 1999b) and from USEPA Region 5 (Micham, 1999c) (which together, according to the inventory, represent approximately 60 percent of the total estimated number of wells nationwide), it appears that permeable treatment systems are not typically regulated as Class V wells. Only in South Carolina have such systems been permitted as Class V wells, and in both states and the region, such permitting is considered on a case-by-case basis. Based on the federal UIC regulatory definition of “fluid” and “injection well,” beyond the dimensions of a treatment wall, the type and physical state of the material placed in the treatment wall and the manner in which that material is placed are some of the factors that would be considered to determine if a Class V permit should be issued (e.g., a treatment wall filled with metal shavings or other solids may not be considered an injection well, while a slurry treatment barrier system or an treatment wall with ORC may be considered injection wells, according to the information provided).

4.2.8 Experimental Wells

Several state UIC programs identified injection wells being used to test innovative aquifer remediation technologies as experimental wells. Typically, these wells are initially permitted as experimental wells by the USEPA Region or state and, once the technology is proven and if the system is to continue operating, the wells are reclassified and the respective permits modified (Micham, 1999d). The wells involve experiments of in situ bioremediation, in situ chemical treatment, and air sparging. Table 13 summarizes information on the injectate and well characteristics as well as the operational practices of the experimental wells at seven sites. Figure 12 provides the schematic diagram of an upgradient injection well system of a pilot test at Power Engineering Company, located in Denver, Colorado.

5. POTENTIAL AND DOCUMENTED DAMAGE TO USDWS

The potential for damage of USDWs associated with ARWs depends on site-specific factors (i.e., hydrogeology, the nature of the injectate and remediation technology, the nature of the contaminants to be remediated, the quality of well construction, and the operating conditions of the remediation system). The fact that the purpose of ARWs is beneficial (i.e., to improve or protect the quality of an aquifer as a unit) and that implementation of an aquifer remediation system, as with any remedial measure, usually requires the approval of appropriate state and/or federal regulatory agencies, suggests that this type of Class V wells poses a low potential for contamination of USDWs. However, as with any system injecting substances at concentrations

Figure 10. Example of a Permeable Treatment Barrier Well Construction

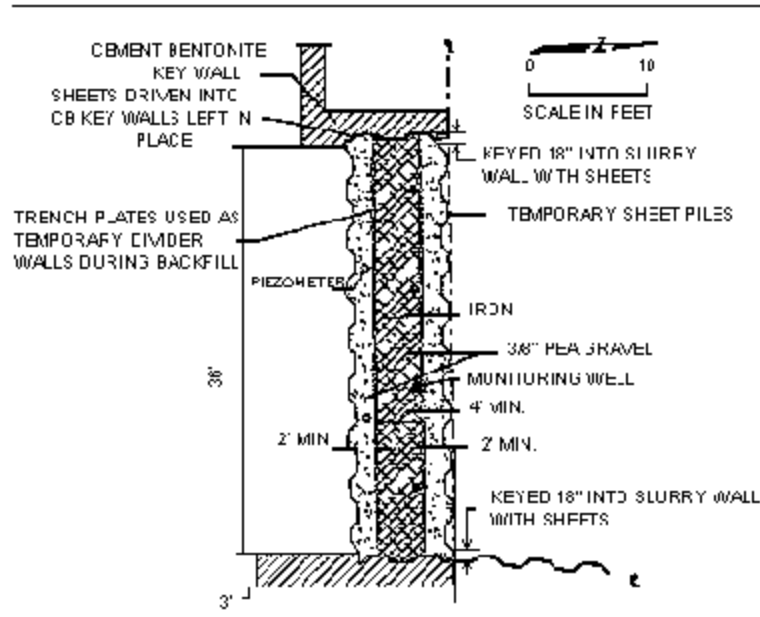
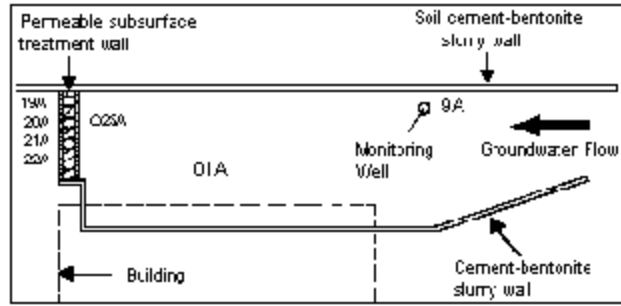

Design Plan for the Permeable Barrier Installed at the Intersil Facility, Sunnyvale, CA, Showing (a) Plan View of Funnel-and-Gate System and (b) Sectional View Through the Gate
 Source: Szerdy et al., 1996

Figure 11. Example of a Permeable Treatment Zone

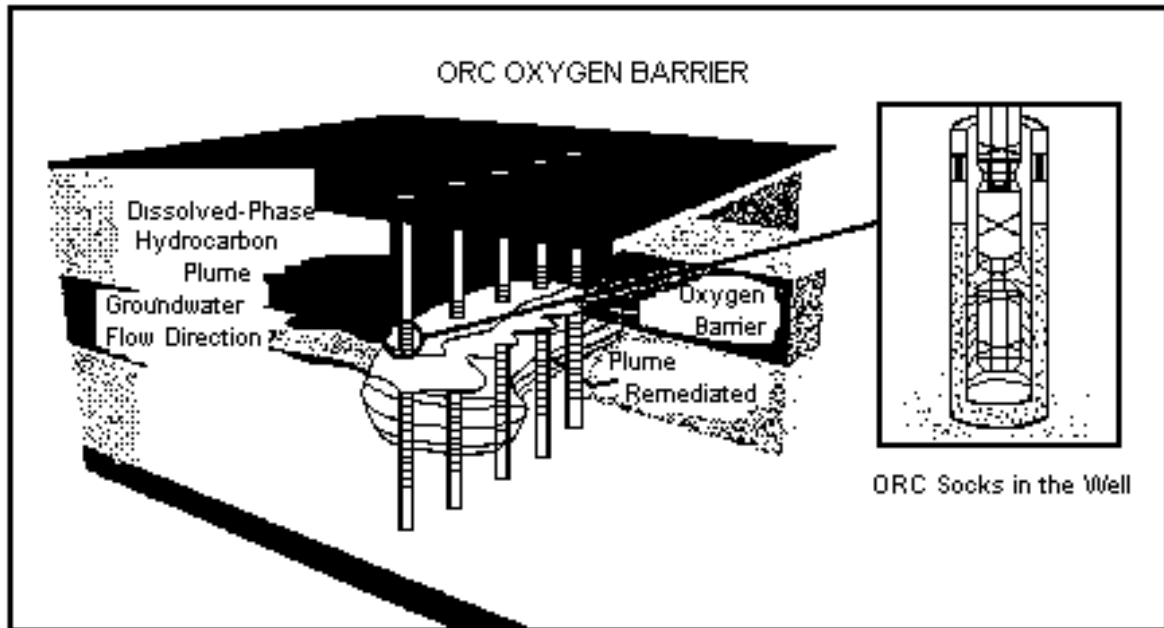

Source: Regenesis, Inc., Manufacturer Literature.

Table 13. A Summary of the Well Characteristics and Operational Practices of Experimental ARWs

Site & Scale	Remediation Agents	Pollutants	Well type	Operational Practices	Reference
Stevens Point Municipal Water Dept., WI	<p>ORC, consisting of a proprietary of:</p> <ul style="list-style-type: none"> ⊆ magnesium oxide (MgO) ⊆ magnesium dioxide (MgC₂) ⊆ magnesium hydroxide (Mg(OH)₂) ⊆ sodium hypochlorite (NaOCl) solution 	⊆ manganese	⊆ in situ bioremediation	<ul style="list-style-type: none"> ⊆ The system consists of 9 wells situated around a municipal water supply well in Stevens Point. < Phase I: 470 lbs of 10 % mixture (as O₂) of ORC; injection rate 5.2 lbs/day, 2 days/week for 24 weeks. < Phase II: 83 lbs of 5.6% NaOCl injected at a rate of 9.3 GPD, 2 days/week for 24 weeks. ⊆ Wells approved for 1-year operation ⊆ Wells subject to WI Admin. Code if standard are exceeded. ⊆ Monitoring for disinfection byproducts including total trihalomethanes (TTHMs) and total haloaceton acids (THMAs) 	<p>SPWSTD, 1998 UWSP, 1999 WDNR, 1998</p>
City of Bay Minette Utilities, AL	⊆ sodium hypochlorite (NaOCl) and water	⊆ bacteriological contamination	⊆ in situ bioremediation	<ul style="list-style-type: none"> ⊆ Five wells around the City of Bay Minette Utilities Board No. 5 drinking water production well ⊆ Approx. 5,000 gallons of a 0.2% solution of NaOCl injected into the wells once a month ⊆ Monthly monitoring reports submitted to Alabama Dept. of Environmental Management ⊆ Concern for formation of trihalomethanes (THMs) 	<p>City of Bay Minette, 1999 USEPA Region 8, 1999</p>

Table 13. A Summary of the Well Characteristics and Operational Practices of Experimental ARWs (cont'd)

Site & Scale	Remediation Agents	Pollutants	Well type	Operational Practices	Reference
Savannah River Site, Aiken, SC	<ul style="list-style-type: none"> ⊆ a gas mixture consisting of air, methane, nitrogen (as nitrous oxide, N₂O), phosphorous (as triethyl phosphate (C₂H₅)₃PO), and helium 	<ul style="list-style-type: none"> ⊆ TCE 	<ul style="list-style-type: none"> ⊆ air sparging 	<ul style="list-style-type: none"> ⊆ The well system consisted of 3 gas sparge wells, a gas extraction well, and 14 nested ground water monitoring points at various points in the saturated and unsaturated zones ⊆ The gas mixture injected into the sparge wells consisted of 15 standard ft³/min of air blended with 4% methane, 0.07% N₂O, 0.007-0.01% (C₂H₅)₃PO, and 1.0% helium injected as a tracer gas. Injection took place 8 hours a day for six consecutive days 	Brigmon et al., 1998
North Carolina State University In Situ Bioremediation Research Projects, NC	<ul style="list-style-type: none"> ⊆ nutrients and a NaCl tracer 	<ul style="list-style-type: none"> ⊆ aromatic hydrocarbons 	<ul style="list-style-type: none"> ⊆ in situ bioremediation 	<ul style="list-style-type: none"> ⊆ Three experimental ARWs with a total of 14 wells. Each well is approx. 17 feet deep, with 2-inch inner stainless steel casing diameter and 24-inch outer steel casing diameter; 6-inch diameter concrete pad and 18-inch bentonite seal ⊆ Each well is equipped with sampling ports to sample injectate and ground water quality 	NCDENR, 1999

Table 13. A Summary of the Well Characteristics and Operational Practices of Experimental ARWs (cont'd)

Site & Scale	Remediation Agents	Pollutants	Well type	Operational Practices	Reference
USGS experimental aquifer remediation study, Julesburg, CO	<ul style="list-style-type: none"> ☐ denatured ethanol (EtOH) ☐ methanol ☐ potassium bromide (KBr) tracer 	<ul style="list-style-type: none"> ☐ nitrates 	<ul style="list-style-type: none"> ☐ in situ bioremediation (denitrification) 	<ul style="list-style-type: none"> ☐ The USGS proposed to install 10 to 12 injection wells around a former drinking water production well. ☐ Denatured EtOH in water was injected at a concentration of 40 mg/l (as EtOH). A total of 2,000 gallons of denatured EtOH was anticipated to be injected over the course of the study. The maximum injectate concentration of MeOH from the denatured ethanol was 5 mg/l and the maximum concentration of EtOH was 70 mg/l (USGS 1996a). The KBr tracer was injected periodically at a concentration of 25 mg/l and it was anticipated that a total of 5 kilograms of KBr would be injected over the course of the study 	USGS, 1996a
SECOR International Hydrofracture Pilot Test, CO	<ul style="list-style-type: none"> ☐ aqueous slurry consisting of sand, guar (a food-grade additive), a cross-link breaker compound, and borax 	<ul style="list-style-type: none"> ☐ ground water contaminants 	<ul style="list-style-type: none"> ☐ air stripping; soil vapor extraction system 	<ul style="list-style-type: none"> ☐ two shallow wells and two deep wells are proposed for a hydraulic fracturing pilot test 	Rubin, 1999

Table 13. A Summary of the Well Characteristics and Operational Practices of Experimental ARWs (cont'd)

Site & Scale	Remediation Agents	Pollutants	Well type	Operational Practices	Reference
Power Engineering Company (PEC) aquifer remediation pilot test, CO	C calcium polysulfide	C chromium (VI)	C in situ reduction reaction	C PEC proposed to inject 520 GPD of calcium polysulfide into shallow aquifer upgradient of facility through 10 pairs of 1-inch PVC wells at one location. Injection rate of 0.12 GPM per well would achieve a 1% concentration of polysulfide in the aquifer. (Initial proposal of an injection rate of 0.18 GPM resulting in a 3% concentration of polysulfide was rejected because of potential impact to nearby river.)	Slosky & Company, 1998 USEPA Region 8, 1999

**Figure 12. Schematic Diagram of the Upgradient Injection Well System
Power Engineering Company Pilot Test, Denver, CO**

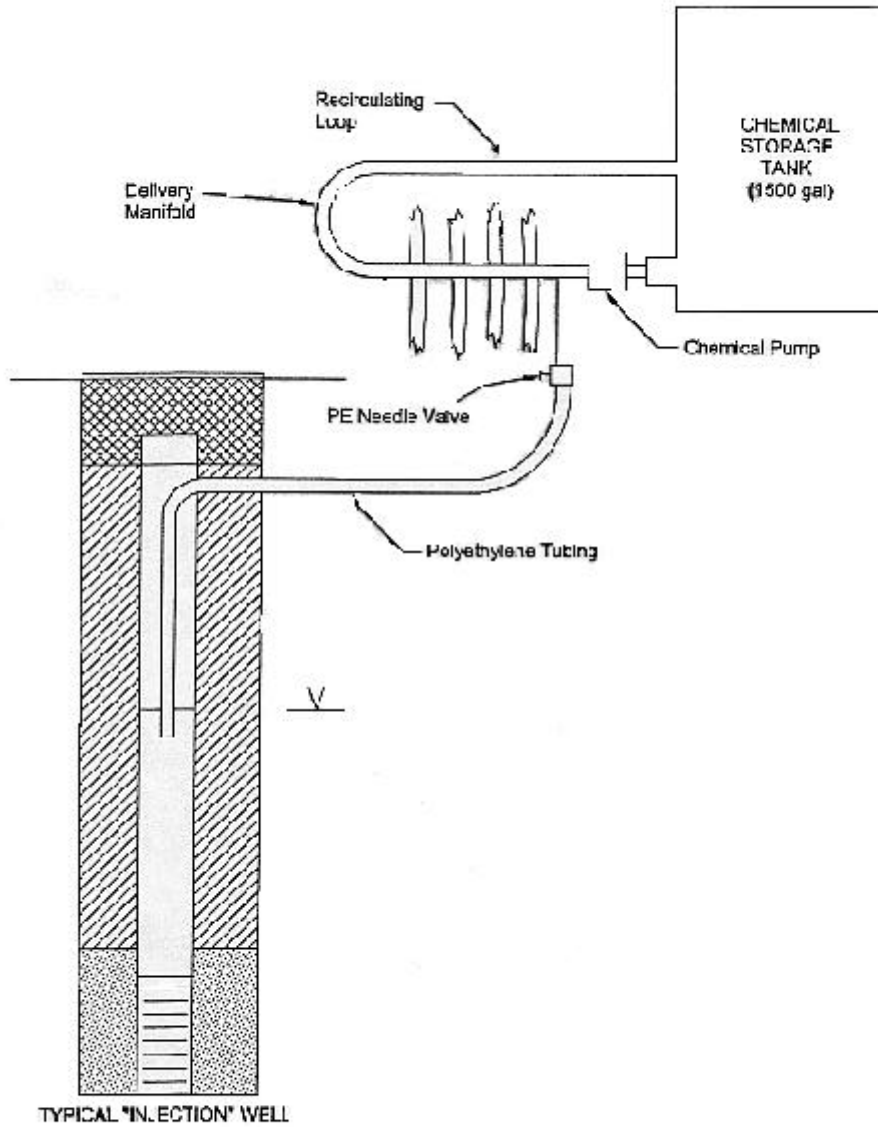

Drawing not to Scale		FLOW SCHEMATIC OF CHEMICAL DELIVERY SYSTEM	
	SLOSKY & COMPANY, INC. 1675 Broadway, Suite 1400, Denver, Colorado 80202		POWER ENGINEERING COMPANY 2525 S. Delaware, Denver, Colorado 80223

Figure

above MCLs into the subsurface, the potential for damage to USDWs exists, especially in instances involving voluntary cleanups that have not been adequately reviewed and approved by experts. Nevertheless, in some USEPA Regions, voluntary cleanups are periodically the subject of inspections by state regulatory agencies (Micham, 1999a). In addition, it is noted that improper plugging upon completion of cleanup would pose potential risk to the ground water aquifer (Micham, 1999a).

For example, a failure in the treatment train of a pump-and-treat aquifer remediation system may potentially lead to the injection of untreated ground water back into the contaminated aquifer, or to a different formation, which may be a clean aquifer. This latter case was reported in an incident that occurred in Arizona, which is described in Section 5.2. Proper design and operation of the system would prevent the occurrence of such an incident and proper monitoring could ensure early detection and correction. In the event of an incident, the potential for damage of USDWs depends on the site-specific factors mentioned above, as well as on the magnitude of the incident itself (i.e., amount of contaminants injected, duration of the incident).

The purpose of injecting any reagent or nutrient into an ARW is precisely its participation in a physico-chemical or a biological reaction within the affected aquifer. However, a variety of problems may occur, which may interfere with that purpose. Such problems include short-circuiting through preferential paths (e.g., cracks and faults), which would prevent proper mixing. As a result, a reagent would not react or be consumed completely, but rather, it would potentially be transported beyond the limits of the original contaminant plume at concentrations that may exceed MCLs or SMCLs. Additionally, chemical precipitation of soluble salts or excessive bacterial growth may lead to a loss of effective soil porosity, which would also affect proper mixing and reduce the effectiveness of reactions. Furthermore, unexpected physico-chemical and/or biological reactions between the injected reagents or nutrients and the existing contaminants or naturally occurring constituents present in the aquifer may result in the generation of compounds not previously present, which could potentially damage a USDW if they were not contained. These issues must be taken into consideration during the design, implementation, and monitoring of any in situ aquifer remediation project.

Lastly, it is possible for injected steam to change the chemistry of the formation such that the potential mobilization of previously immobile constituents could occur. This phenomenon has not yet been documented to have occurred in full-scale ARW, but it has been observed in experimental ARWs.

5.1 Injectate Constituent Properties

The primary constituent properties of concern when assessing the potential for Class V ARWs to adversely affect USDWs are toxicity, persistence, and mobility. The toxicity of a constituent is the potential of that contaminant to cause adverse health effects if consumed by humans. Appendix D to the Class V Study provides information on the health effects associated with contaminants found above drinking water standards or health advisory limits in the injectate of ARWs and other Class V wells.

Persistence is the ability of a chemical to remain unchanged in composition, chemical state, and physical state over time. Appendix E to the Class V Study presents published half-lives of common constituents in fluids released in ARWs and other Class V wells. All of the values reported in Appendix E to the Class V Study are for ground water. Caution is advised in interpreting these values because ambient

conditions have a significant impact on the persistence of both inorganic and organic compounds. Appendix E to the Class V Study also provides a discussion of mobility of certain constituents found in the injectate of ARWs and other Class V wells.

As presented in Section 4.1 of this volume, a wide variety of constituents may be present in the injectate of ARWs. It is fair to say that most reagents are not toxic (e.g., bioremediation nutrients), although there are exceptions (e.g., certain organic compounds used as substrates in in-situ bioremediation and certain co-solvents used as in-situ flushing agents). The instances when a constituent is present in the injectate of an ARW at a concentration that may exceed the respective MCL or HAL are related to either the injection of treated water, as in a pump-and-treat system, or to the injection of certain biological or chemical agents.

The universe of constituents that may be present in the injectate of pump-and-treat systems in the United States is as extensive as the universe of constituents present in contaminated aquifers. Therefore, a detailed discussion on the properties of those constituents is beyond the scope of this document. When the contaminated aquifer receives the injectate (which is typical), the concentration of the constituents of concern in the injectate will typically be lower, and at most equal (e.g., in the event of a system failure), to the concentration in the untreated ground water. For the contaminants present in the injectate that are also present in the untreated (pumped) ground water, the persistence and mobility characteristics of the contaminants following injection is generally expected to be similar to those prior to pumping.

Reagents injected into remediation wells are generally mobile but not persistent. They are mobile by design, because contact with the ground water to be treated is required for the system to be effective.⁴ Chemical reagents are generally not persistent in the ground water environment at a remediation site because they react with the contaminants as part of the treatment process. Biological reagents (microbes) are persistent as long as their food source (the contaminants) is available, but die and decay as the contaminant concentrations are reduced.

5.2 Impacts on USDWs

ARWs that inject reagents or nutrients are operated as part of a specific aquifer remediation technology. The conditions of the operation of such a system, including injectate properties, are generally designed specifically to address a particular type of aquifer contamination (e.g., heavy metals, chlorinated organic compounds). Overall, ARWs appear to be unlikely to contribute to ground water contamination. The fact that, in general, aquifer remediation projects involve the operation of monitoring wells implies that contamination incidents would be detected relatively quickly if they occur. Information related to contamination incidents associated with the operation of ARWs is very limited (Cadmus, 1999). Only one contamination incident in Arizona and two potential contamination incidents were reported, one in Kentucky and one in Colorado, as described below.

⁴ Some reagents are more less mobile than others, of course. Mobility is taken into account in system design in that the density of the injection well network will generally be greater for less mobile reagents to ensure contact with all of the ground water to be treated.

Some state regulators perceive that, in general, ARWs appear to be operating properly, based on ground water monitoring results. In Ohio, even though the remediation systems that these wells are a part of are not necessarily successful in remediating the subject aquifers, no contamination is known to have occurred as a result of the operation of an ARW (Ohio regulator as reported in Cadmus, 1999).

Contamination Incident at the Hassayampa Landfill Superfund Site, Arizona. The Arizona Department of Environmental Quality (ADEQ) reported an incident associated with an aquifer remediation system (Cadmus, 1999). The Hassayampa Landfill Site is an unlined solid waste landfill site where hazardous wastes were disposed of. Hazardous constituents leaked and impacted the underlying aquifer (Unit A). The contaminants included chlorinated organics such as 1,1-dichloroethane (1,1-DCA); 1,1-dichloroethene (1,1-DCE); 1,2-dichloroethene (1,2-DCE); 1,1,1-trichloroethane (1,1,1-TCA); and trichloroethene (TCE). A pump-and-treat system using air stripping technology was set up. In March 1998, after several months of operation of the treatment system, the air stripping unit failed (i.e., blower failure). However, the injection system was not cut off, leading to the injection of untreated water into a deeper aquifer (Unit B), which was a clean drinking water aquifer, over a period of almost ten hours. The estimated volume of contaminated water that was injected into Unit B was approximately 4,275 gallons. ADEQ required monitoring of Unit B over a four month period and re-design of the appropriate parts of the air stripping system to prevent further incidents of contamination. The requested monitoring did not take place and ADEQ collected samples six months after the incident occurred. The analyses of those samples did not detect any of the hazardous constituents that had leaked from the landfill (Victor, 1999).

Potential Contamination During Surfactant Demonstration Project, Kentucky. A proposed surfactant demonstration project to facilitate removal of TCE from ground water at the DOE's Paducah Gaseous Diffusion Plant in Kentucky apparently resulted in migration of the surfactant, as reported by the state's Division of Waste Management, Federal Facility Oversight Unit. During the demonstration, the contractor was unable to recover all of the surfactant, some of which may have either moved down gradient or was bound up in the matrix. Documentation of this case was not available. According to the Federal Facility Oversight, potential causes for the failure of the demonstration included inadequate pumping rate and poor preliminary geologic assessment prior to the demonstration. Nevertheless, after this incident, state regulators remained interested in the application of surfactants to enhance the performance of pump-and-treat systems (USEPA, 1995a).

Potential Impact of Sulfides at Power Engineering Company (PEC), Colorado, Pilot Test. Calcium polysulfide was used as injectate for experimental in situ remediation of a shallow aquifer contaminated with hexavalent chromium at the PEC facility. Both the ground water plume and the injection zone were located near the South Platte River and the plume flowed in the direction of the river. USEPA Region 8, the authorizing agency for this project, expressed concern that the injection of calcium polysulfide could result in formation and migration of bisulfide ions (HS^-) and hydrogen sulfide (H_2S) that are toxic to fish, and are more toxic than the hexavalent chromium being remediated (USEPA Region 8, 1999). USEPA Region 8 restricted injection to upgradient wells and made this a pilot study because of lack of adequate data regarding persistence of reaction and dissociation products, particularly sulfides, after injection. At the PEC site, the downgradient wells were very near to the South Platte River, and USEPA Region 8 wanted to prevent sulfides from entering that stream and affecting the fish. USEPA Region 8 indicated that recent

monitoring data from the PEC site show that sulfide was detected at several of the downgradient wells. The injection rate of calcium polysulfide was reduced upon the detection of sulfides and since then sulfides have not been detected. An additional problem was posed by the distribution of calcium polysulfide in the ground water plume after injection. The injectate being denser than the ground water, it migrated to the bottom of the plume and did not treat the chromium (VI) within the shallow portion of the plume. To address this problem, the injectate is being diluted to reduce the density difference between the injectate and the ground water.

6. BEST MANAGEMENT PRACTICES

Best management practices that are applicable to ground water wells in general (e.g., selection of well construction materials) obviously are also relevant to ARWs. Additionally, there are some BMPs that are specific to the different types of ARWs.

6.1 Selection of Well Construction Materials

Materials used for ARWs are similar to those for water wells (Miller, 1996a). Possible choices of well construction materials include:

- C fiber reinforces plastic (FRP);
- C fiberglass reinforced epoxy (FRE);
- C high density polyethylene (HDPE);
- C high temperature polyethylene (HTPE);
- C polyvinyl chloride (PVC);
- C stainless steel; and
- C porous polyethylene well screen.

Well materials must be compatible with the contaminants being removed and the remediation technology being employed. Well materials have been shown to be reactive with specific types of contaminants and ground water conditions. Stainless steel can be susceptible to leaching dissolved metals under anoxic conditions. Creosote wastes pumped under pressure can weaken and cause PVC to fail, thus creosote manufacturers recommend using steel. At a Superfund site in Texas, NAPLs caused a dedicated PVC bailer to fuse with the PVC well casing material inside a monitoring well. This caused permanent damage to the well and resulted in its abandonment. The use of an alkaline polymer surfactant (APS) at a creosote contaminated waste site in Laramie Wyoming caused the complete destruction of PVC piping (McCaulou et al., 1995).

Structural integrity of the well systems can be affected by the presence of NAPLs and high concentrations of dissolved organic compounds in ground water (McCaulou et al., 1996). McCaulou and Huling (1999) observed incompatibility between DNAPLs and bentonite. It was found the intrinsic permeability of water hydrated bentonite was 46 to 2,640 times greater to DNAPLs, thus developing desiccation cracks that detriment the well system. A chemical compatibility table for 73 chemicals and 28 commonly used materials was compiled based on laboratory tests and literature review (McCaulou et al., 1996).

Many manufacturers recommend compatibility testing of well materials and equipment before installation in a remediation system. However, even short-term testing may not indicate problems that would only become evident over the extended duration of a remediation project (McCaulou et al., 1995). Monitoring of well apparatus and equipment is thus highly appropriate to ensure minimizing system failures.

6.2 Compatibility with Site Conditions

An important consideration is the compatibility of aquifer remediation reagents with soil formation minerals and contaminants - beyond the primary contaminants of concern - present in the ground water. A potential reaction could result in the formation of complexes that may significantly reduce injection rates and potentially impact contaminant removal rates. Aquifer clogging or plugging may occur as a result of changes in aquifer characteristics due to an increase in iron precipitation or biomass accumulation caused by oxygen injections (Miller, 1996b).

An additional site specific consideration is the compatibility of the site lithology and soil heterogeneity with the mass transfer mechanisms associated with a particular aquifer remediation system. For example, air sparging would be ineffective if applied at a site where a low-permeability layer overlies the aquifer. Similarly, heterogeneous soils may cause channeling (preferential movement of a fluid - liquid or gas - through high conductivity layers and potentially away from the area of contamination) (Miller, 1996a). When low permeability clay lenses are present in an aquifer, the injected fluids often bypass these low permeability areas and, therefore, do not contact the contaminants contained within them (USEPA, 1997a).

A report on state regulators' perspectives and experiences with the use of surfactant injection for ground water remediation (USEPA, 1995a) presents some recommendations from a California regulator regarding the most important technical considerations associated with ARWs. The considerations included the following: (1) certainty of hydrogeologic control (for both surfactants and tracers) and (2) an understanding of the interaction of the surfactant with the contaminant and the media. The monitoring system in place must be able to address those two issues (USEPA, 1995a). Although these considerations specifically address the use of surfactants, they are relevant, and may be extrapolated, to the operation of aquifer remediation injection wells in general. The operation of monitoring wells is critical to establish whether the system is performing as planned, without exceeding ground water quality standards beyond the area of contamination as a direct result of the operation of the aquifer remediation injection well.

6.3 Well Systems

The following sections discuss some specific design, construction, and implementation issues and best management practices of individual well systems.

6.3.1 Pump-and-Treat

In addition to site characterization, design and operation of a pump-and-treat system are key components of the effective remediation of the system. As with any wells system, mathematical models are developed to capture the hydrogeologic characteristics of the site and provide insights to the flow patterns of

alternative treatment approaches. Optimization programming may be used to improve the system design (USEPA, 1996a). Construction of extraction wells and injection wells may be carried out with subsequent phases. Based on the monitoring results, the siting of subsequent wells could reflect the effectiveness of contaminant removal. The contaminant removal and re-injection rates may be maximized by operating the extraction and injection wells with an adaptive manner. It has been found that pulsed pumping can increase the contaminant concentration in pumped ground water and, therefore, could be used to improve contaminant removal.

6.3.2 Air Sparging

A basic objective of the design of an air sparging system is to ensure that the aeration of the contaminated soils occurs with little or no uncaptured volatilization. The blower, vent wells, and piping can be designed after making decisions about the required air flow system, air flow rates, and well spacing (USEPA, 1995b). In any case, the system must be carefully monitored to prevent possible health or safety violations, which can include ground water mounding, vapor migration, or increased mixing which in turn increases mass transfer of contaminants to ground water and vapor phases (Miller, 1996b).

6.3.3 Steam Injection

Injection pressure must be lower for shallow treatment zones than for deeper ones. High pressure can cause fractures which allow steam to escape to the surface, or gravity can cause steam override, both of which decrease efficiency. Special care must be taken in choosing materials to construct the steam injection well, due to both the high pressures and temperature involved. Also, the water is generally treated to prevent scale buildup in the generator. (Davis, 1998a).

6.3.4 Permeable Treatment Barrier Systems

Treatability studies and other field research can help determine the effectiveness of treatment walls. Specifically, it is important to determine the reactive media to be used and the reaction zone size. Even with the proper medium, the type of contaminant being treated may affect design choices. For example, radioactive contaminants can accumulate on the surface of the reactive medium, resulting in the need to replace the treatment wall.

Prolonging the life of the reactive medium is important to the success of this technology, and although some techniques have been developed, there are still concerns that gradual loss of media reactivity will decrease the effectiveness of the barrier. Barriers at depths of 10 - 30 m are currently not cost-efficient. To increase the effectiveness of this technology, other technologies such as in situ soil washing are used in combination with it (Vidic and Pohland, 1996).

7. CURRENT REGULATORY REQUIREMENTS

Several federal, state, and local programs exist that either directly manage or regulate Class V ARWs. On the federal level, management and regulation of these wells fall primarily under the underground injection control program authorized by the Safe Drinking Water Act (SDWA). Some states and localities have used

these authorities, as well as their own authorities, to extend the controls in their areas to address endemic concerns associated with ARWs.

Aquifer remediation injection wells potentially are subject to at least three categories of regulation. First, a state's underground injection control program (or in direct implementation states the federal UIC program) may have jurisdiction over such wells. In some states without UIC programs, the state's program for ground water protection or pollution elimination program requirements may apply to remediation wells. Finally, remediation wells are affected by federal and state remediation requirements, arising out of either Superfund programs or corrective action programs under RCRA, the UST program, or other environmental remediation programs. In the case of remediation programs, however, the regulatory requirements typically address the selection of aquifer remediation as a cleanup alternative and establish the degree of required cleanup in soil and/or groundwater, while deferring regulation of the injection wells used in the remediation to other programs. In the case of voluntary cleanup programs, some concern exists because they may not be approved or completed according to standards typical of cleanups overseen by a state or federal agency. Nevertheless, in some USEPA Regions, voluntary cleanups are periodically the subject of inspections by state regulatory agencies (Micham, 1999d).

7.1 Federal Programs

7.1.1 SDWA

Class V wells are regulated under the authority of Part C of SDWA. Congress enacted the SDWA to ensure protection of the quality of drinking water in the United States, and Part C specifically mandates the regulation of underground injection of fluids through wells. USEPA has promulgated a series of UIC regulations under this authority. USEPA directly implements these regulations for Class V wells in 19 states or territories (Alaska, American Samoa, Arizona, California, Colorado, Hawaii, Indiana, Iowa, Kentucky, Michigan, Minnesota, Montana, New York, Pennsylvania, South Dakota, Tennessee, Virginia, Virgin Islands, and Washington, DC). USEPA also directly implements all Class V UIC programs on Tribal lands. In all other states, which are called Primacy States, state agencies implement the Class V UIC program, with primary enforcement responsibility.

ARWs currently are not subject to any specific regulations tailored just for them, but rather are subject to the UIC regulations that exist for all Class V wells. Under 40 CFR 144.12(a), owners or operators of all injection wells, including ARWs, are prohibited from engaging in any injection activity that allows the movement of fluids containing any contaminant into USDWs, "if the presence of that contaminant may cause a violation of any primary drinking water regulation . . . or may otherwise adversely affect the health of persons."

Owners or operators of Class V wells are required to submit basic inventory information under 40 CFR 144.26. When the owner or operator submits inventory information and is operating the well such that a USDW is not endangered, the operation of the Class V well is authorized by rule. Moreover, under section 144.27, USEPA may require owners or operators of any Class V well, in USEPA-administered programs, to submit additional information deemed necessary to protect USDWs. Owners or operators who fail to submit the information required under sections 144.26 and 144.27 are prohibited from using their wells.

Sections 144.12(c) and (d) prescribe mandatory and discretionary actions to be taken by the UIC Program Director if a Class V well is not in compliance with section 144.12(a). Specifically, the Director must choose between requiring the injector to apply for an individual permit, ordering such action as closure of the well to prevent endangerment, or taking an enforcement action. Because ARWs (like other kinds of Class V wells) are authorized by rule, they do not have to obtain a permit unless required to do so by the UIC Program Director under 40 CFR 144.25. Authorization by rule terminates upon the effective date of a permit issued or upon proper closure of the well.

Separate from the UIC program, the SDWA Amendments of 1996 establish a requirement for source water assessments. USEPA published guidance describing how the states should carry out a source water assessment program within the state's boundaries. The final guidance, entitled *Source Water Assessment and Programs Guidance* (USEPA 816-R-97-009), was released in August 1997.

State staff must conduct source water assessments that are comprised of three steps. First, state staff must delineate the boundaries of the assessment areas in the state from which one or more public drinking water systems receive supplies of drinking water. In delineating these areas, state staff must use "all reasonably available hydrogeologic information on the sources of the supply of drinking water in the state and the water flow, recharge, and discharge and any other reliable information as the state deems necessary to adequately determine such areas." Second, the state staff must identify contaminants of concern, and for those contaminants, they must inventory significant potential sources of contamination in delineated source water protection areas. Class V wells, including ARWs, should be considered as part of this source inventory, if present in a given area. Third, the state staff must "determine the susceptibility of the public water systems in the delineated area to such contaminants." State staff should complete all of these steps by May 2003 according to the final guidance.⁵

7.1.2 CERCLA - Superfund Cleanups

According to the Comprehensive Environmental Response, Compensation, and Liability Act (CERCLA or Superfund), all remedial alternatives proposed for a Superfund site cleanup must be evaluated using the nine criteria established in 40 CFR 300.430 (e)(3)(iii). The nine criteria for evaluation are the following:

- C Overall protection of human health and the environment;
- C Compliance with applicable or relevant and appropriate requirements (ARARs) in other federal statutes or regulations;
- C Long-term effectiveness and permanence;
- C Reduction of toxicity, mobility, or volume through treatment;
- C Short-term effectiveness;
- C Implementability;
- C Cost;
- C State acceptance; and
- C Community acceptance.

⁵ May 2003 is the deadline including an 18-month extension.

Under Superfund, requirements for evaluating the effectiveness of a remedy are site-specific and must demonstrate that cleanup levels are achieved. This is generally consistent with RCRA requirements.

The purpose of the federal UIC program is to protect USDWs by prohibiting injections that may affect water quality in USDWs. On a site-specific basis, a contaminated aquifer at a Superfund site may not serve as USDW; under those circumstances, the UIC requirements may not apply to wells at a Superfund site (USEPA, 1996b).

7.1.3 RCRA Corrective Actions

RCRA regulations relevant to corrective actions are addressed in 40 CFR 264.90-101. RCRA requires that a ground water monitoring program be implemented to demonstrate the effectiveness of the corrective action. RCRA corrective action measures may be terminated when ground water monitoring data demonstrate that the contaminant levels are below the ground water protection standard.

Overall, the monitoring program must provide for the determination of the quality of background water that has not been affected by leakage from a regulated unit. Additionally, that monitoring program must yield ground water samples that represent the quality of ground water at the point of compliance, as established in 40 CFR 264.95. RCRA requires that ground water monitoring data be collected from background wells and wells at the compliance point(s) and that the data be maintained in the facility operating record. Reporting frequency is established by the Regional Administrator on a site-specific basis.

Under RCRA, the concentration limits in the ground water for hazardous constituents to be achieved through corrective action are established in the permit (40 CFR 264.94(a)). RCRA allows the EPA Regional Administrator to establish alternate concentration limits, provided that such limits are protective of human health and the environment.

7.1.4 Underground Storage Tank (UST) Program

In the event of a release from a UST system, an implementing agency under the UST program (40 CFR 280.60) may require owners and operators to develop and submit a corrective action plan for responding to contaminated soils and ground water. The implementing agency will ensure that the plan will adequately protect human health, safety, and the environment. The factors that the implementing agency must take into consideration, as appropriate, are as follows:

- C The physical and chemical characteristics of the regulated substance, including its toxicity, persistence, and potential for migration;
- C The hydrogeologic characteristics of the facility and the surrounding area;
- C The proximity, quality, and current and future uses of nearby surface water and ground water;
- C The potential effects of residual contamination on nearby surface water and ground water;
- C An exposure assessment; and
- C Any information assembled in compliance with the UST program.

40 CFR 280.66(c) establishes that owners and operators must monitor, evaluate, and report the results of implementing the plan.

7.2 State and Local Programs

ARWs are found in many states, although based on the inventory presented in Section 3, a significant portion of such wells are located in Kansas, Ohio, South Carolina, and Texas, which combined account for approximately 65 percent of all documented ARWs. Selected state programs relevant to Class V wells were reviewed in these four states, as well as five other states where substantial numbers of ARWs are found (Arizona, California, Colorado, Nevada, and New Hampshire) to provide a geographical sample of regulations for this type of well. Altogether, these nine states have a total of 7,198 documented ARWs, which corresponds to approximately 70 percent of the documented well inventory for the nation based on a survey conducted by the USEPA of the state and regional staff that administer the UIC programs (Cadmus, 1999).

In three of the nine states, Arizona, California, and Colorado, the USEPA Region directly implements the UIC Class V program in the state. All three states, however, also have enacted state requirements that can be used to regulate some ARWs. Arizona's Department of Environmental Quality issues Aquifer Protection Permits under the state's aquifer protection program. This permitting authority does not cover remedial actions for releases of hazardous substances, but does cover remediation of ground water contaminated by petroleum. California's Water Quality Control Act creates Regional Water Quality Control Boards that can prescribe requirements for discharges to ground water. Control boards issue site-specific orders addressing sites using reinjection of treated ground water in a remedial action. Colorado's State Engineer has authority to issue permits for well construction.

Of the six states that were reviewed with primacy for the UIC Class V program, individual permits are also required for ARWs in Arizona, Kansas, Nevada, Ohio (required for those wells expected to exceed MCLs), and South Carolina. ARWs may be authorized by rule in New Hampshire and Texas, although such authorization is prohibited if the well causes or allows the movement of fluid that would contaminate a USDW. In summary, individual permits are required for at least half of the documented ARWs.

No state has a direct regulatory prohibition on injection technologies for treating contaminated aquifers. Until recently, a few states prohibited the use of injectants, either through bans on new Class V injection wells or prohibition of injectants that did not meet ground water quality criteria. Currently, exceptions are made for Class V remediation wells, and the states that prohibit injection of fluids that do not meet ground water quality standards allow the use of site-specific criteria for contaminated aquifers (USEPA, 1996b). However, in some cases, local regulations may prohibit any type of injection well (e.g., Merced County, California).

Attachment A of this volume presents a more detailed overview of the state programs relevant to ARWs for the nine states summarized above.

ATTACHMENT A STATE AND LOCAL PROGRAM DESCRIPTIONS

This attachment presents an overview of the selected state programs relevant to ARWs for the four states (Kansas, Ohio, South Carolina, and Texas) where, based on the inventory presented in this volume, a significant portion of such wells are located. (The four states combined account for approximately 65 percent of all documented ARWs). The overview also includes regulations from other states (Arizona, California, Colorado, Nevada, and New Hampshire) selected to provide a geographical sample of regulations for this type of well. Altogether, these nine states have a total of 7,198 documented ARWs, which correspond to approximately 70 percent of the documented well inventory for the nation based on a survey conducted by the USEPA of the state and regional staff that administer the UIC programs (Cadmus, 1999). The overview also includes some examples of local programs.

Arizona

USEPA Region 6 directly implements the UIC program for Class V injection wells in Arizona. The state has not enacted regulations pertaining to underground injection wells. The state has enacted a ground water protection statute, however, that could address ARWs. Under the Arizona Revised Statutes (Title 49, Chapter 2, Article 3 - Aquifer Protection Permits) any facility that “discharges” is required to obtain an Aquifer Protection Permit (APP) from the Arizona Department of Environmental Quality (ADEQ) (§49-241.A). An injection well is considered a discharging facility and is required to obtain an APP, unless ADEQ determines that it will be “designed, constructed, and operated so that there will be no migration of pollutants directly to the aquifer or to the vadose zone” (§49-241.B).

The APP requirements do not cover all remedial activities. Under the authority of §49-250 of the statute, the APP rules provide that they do not apply to activities conducted pursuant to a remedial action order issued or a plan approved pursuant to §§49-281 through 49-287 and Rules 18-7-101 through 18-7-110. Sections 49-281 through 49-287 and associated rules pertain to remedial actions for the release or threat of release of hazardous substances. Under 49-282.06.A.4, ground water remedial actions may include controlled migration, physical containment, and plume remediation. An injection well used to remediate ground water that is not affected by hazardous substances (e.g., petroleum as defined in §49-1001 is not a hazardous substance in Arizona, except to the extent that certain constituents of petroleum are subject to 49-283.02) is subject to the APP requirements. An injection well used to remediate hazardous substances is subject to the remedial action requirements, which include preparation of a remedial investigation and feasibility study and a remedial action plan.

The aquifer protection statute provides that an applicant for an APP permit may be required to provide information on the design, operations, pollutant control measures, hydrogeological characterization, baseline data, pollutant characteristics, and closure strategy. Operators must demonstrate that the facility will be designed, constructed, and operated as to ensure greatest degree of discharge reduction and aquifer water quality will not be reduced or standards violated. By rule, presumptive best available demonstrated control technology, processes, operating methods or other alternatives, in order to achieve discharge reduction and water quality standards, are established by ADEQ (§49-243).

An APP may require monitoring, recordkeeping and reporting, contingency plan, discharge limitations, compliance schedule, and closure guidelines. The operator may need to furnish information, such as past performance, and technical and financial competence, relevant to its capability to comply with the permit terms and conditions. A facility must demonstrate financial assurance or competence before approval to operate is granted. Each owner of an injection well to whom an individual permit is issued must register the permit with ADEQ each year (§49-243).

ADEQ designates a point or points of compliance for each facility receiving a permit. The statute defines the point of compliance as the point at which compliance with aquifer water quality standards shall be determined and is a vertical plane down gradient of the facility that extends through the uppermost aquifer underlying that facility. If an aquifer is not or reasonably will not foreseeable be a USDW, monitoring for compliance may be established in another aquifer. Monitoring and reporting requirements also may apply for a facility managing pollutants that are determined not to migrate (§49-244).

Permitting

The Arizona Aquifer Protection Permit Rules (Chapter 19, sub-chapter 9, October 1997) define an injection well as “a well which receives a discharge through pressure injection or gravity flow.” Any facility that discharges is required to obtain an individual APP from ADEQ, unless the facility is subject to a general permit. Permit applications must include specified information. This includes topographic maps, facility site plans and designs, characteristics of past as well as proposed discharge, and best available demonstrated control technology, processes, operating methods, or other alternatives to be employed in the facility. In order to obtain an individual permit, a hydrogeologic study must be performed. This study must include a description of the geology and hydrology of the area; documentation of existing quality of water in the aquifers underlying the site; any expected changes in the water quality and ground water as a result of the discharge; and the proposed location of each point of compliance (R18-9-108).

Well Construction Standards

No injection wells may be constructed unless an APP has been completed and approved. Wells are required to be constructed in such a manner as not to impair future or foreseeable use of aquifers. Specific construction standards are determined on a case-by-case basis.

Operating Requirements

All wells must be operated in such a manner that they do not violate any rules under Title 49 of the Arizona Revised Statutes, including Article 2, relating to water quality standards, and Article 3, relating to APPs. Water quality standards must be met in order to preserve and protect the quality of waters in all aquifers for all present and reasonably foreseeable future uses.

Monitoring Requirements

Monitoring generally will be required for ARWs to ensure compliance with APP conditions.

Monitoring may include both injectate monitoring and monitoring of the injection site. The permit establishes, on a case-by-case basis, alert levels, discharge limitations, monitoring, reporting, and contingency plan requirements. Alert level is defined as a numeric value, expressed either as a concentration of a pollutant or a physical or chemical property of a pollutant, which serves as an early warning indicating a potential violation of any permit condition. If an alert level or discharge limitation is exceeded, an individual permit requires the facility to notify ADEQ and implement the contingency plan (R18-9-110).

Financial Assurance

An individual permit requires that a owner have and maintain the technical and financial capability necessary to fully carry out the terms and conditions of the permit. The owner must maintain a bond, insurance policy, or trust fund for the duration of the permit (R-18-9-117).

Plugging and Abandonment

Temporary cessation, closure, and post-closure requirements are specified on a case-by-case basis. The facilities are required to notify ADEQ before any cessation of operations occurs. A closure plan is required for facilities that cease activity without intending to resume. The plan describes the quantities and characteristics of the materials to be removed from the facility; the destination and placement of material to be removed; quantities and characteristics of the material to remain; the methods to treat and control the discharge of pollutants from the facility; and limitations on future water uses created as a result of operations or closure activities. A post-closure monitoring and maintenance plan is also required. This plan specifies duration, procedures, and inspections for post-closure monitoring (R-18-9-116).

California

USEPA Region 9 directly implements the UIC program for Class V injection wells in California. The California Water Quality Control Act (WQCA), however, established broad requirements for the coordination and control of water quality in the state, set up a State Water Quality Control Board, and divided the state into nine regions, with a Regional Water Quality Control Board that is delegated responsibilities and authorities to coordinate and advance water quality in each region (Chapter 4 Article 2 WQCA). A Regional Water Quality Control Board can prescribe requirements for discharges (waste discharge requirements or WDRs) into the waters of the state (13263 WQCA). These WDRs can apply to injection wells (13263.5 and 13264(b)(3) WQCA). In addition, the WQCA specifies that no provision of the Act or ruling of the State Board or a Regional Board is a limitation on the power of a city or county to adopt and enforce additional regulations imposing further conditions, restrictions, or limitations with respect to the disposal of waste or any other activity which might degrade the quality of the waters of the state (13002 WQCA). In some cases, however, actions taken by regulatory agencies to protect or restore the environment are exempted from otherwise applicable regulatory standards by California law.

Permitting

The WQCA provides that any person operating, or proposing to operate, an injection well (as defined

in §13051 WQCA) must file a report of the discharge, containing the information required by the appropriate Regional Board, with that agency (13260(a)(3) WQCA). Furthermore, the Regional Board, after any necessary hearing, may prescribe requirements concerning the nature of any proposed discharge, existing discharge, or material change in an existing discharge to implement any relevant regional water quality control plans. The requirements also must take into account the beneficial uses to be protected, the water quality objectives reasonably required for that purpose, other waste discharges, and the factors that the WQCA requires the Regional Boards to take into account in developing water quality objectives, which are specified in §13241 of the WQCA ((13263(a) WQCA). However, a Regional Board may waive the requirements in 13260(a) and 13253(a) as to a specific discharge or a specific type of discharge where the waiver is not against the public interest (13269(a) WQCA).

Two examples of the requirements imposed by Regional Water Quality Control Boards on remedial wells are the following. The California Central Valley Region in Order No. 96-138 and the North Coast Region in Order No. 96-022 have both issued site-specific WDRs to sites using re-injection of treated ground water in a remedial action. These WDRs have required geologic well logs, an engineering installation report, certifications of proper installation, and have included maximum contaminant levels for the injectate and site-specific monitoring and reporting programs. The Central Valley Board cited as authority the State Water Resources Control Board Resolution No. 92-49, which provides that dischargers shall cleanup and abate the effects of discharges in a manner that promotes attainment of background water quality or the highest water quality that is economically and technically feasible. The Central Valley Board also cited its own Water Quality Control Plan, which contains beneficial use designations and water quality objectives for all waters of the Basin. The Board noted that the action to adopt waste discharge requirements for the facility is exempt from the provisions of the California Water Quality Act, under California Code of Regulations 14, §§15308 and 15269. Section 15308 provides that actions by regulatory agencies for protection of the environment may be exempted from certain regulatory processes, although relaxation of standards allowing environmental degradation is not included in the exemption. Section 15269 provides that specific actions necessary to prevent or mitigate an emergency are exempt from the requirements of the California Environmental Quality Act.

The North Coast Regional Board cited CERCLA and the Department of Defense Installation/Restoration Program as authority for the ground water cleanup system. It also cited the Board's own Water Quality Control Plan for the Basin. Under the Public Resources Code, Section 21000 et seq. It specified that the discharger was required to protect the environment to the greatest degree possible. Finally, it noted that the discharge was exempt from the requirements of Chapter 15, Division 3, Title 23 of the California Code of Regulations, pursuant to Section 2511(b) because the Board had issued waste discharge requirements, the discharge complied with the Basin Plan, and the wastewater does not need to be managed as a hazardous waste. Section 2511 (d) provides that actions taken by or at the direction of public agencies to cleanup or abate conditions of pollution or nuisance arising from unintentional or unauthorized releases of waste or pollutants to the environment are exempt from certain Water Code requirements.

California counties also may enact requirements for ARWs. In some cases, they may prohibit certain categories of wells entirely. For example, Merced County prohibits the construction of "recharge/injection wells," defined in part as wells constructed to "introduce water, nutrients, and/or microbes for the purpose of

subsurface contamination treatment” (Merced County Code 9.28.060.B and 9.28.020 S).

Colorado

USEPA Region 8 directly implements the UIC program for Class V injection wells in Colorado. However, the State Engineer issues permits to construct wells. The Water Well Construction Rules (2 Colorado Code 402-2) apply to well construction contractors and drillers and to the construction of water wells, test holes, dewatering wells, monitoring and observation wells, and well plugging and sealing (abandonment). The rule specifies that excavations that do not penetrate through a confining layer between aquifers recognized by the State Engineer may be designed, constructed, used, and plugged and sealed by authorized individuals, as specified in the rule, who are not a licensed well construction contractor. Wells constructed for sampling, measuring and test pumping for scientific, engineering, and regulatory purposes that do not penetrate a confining layer may be constructed by an authorized individual.

Kansas

Kansas is a UIC Primacy State for Class V wells. It has incorporated the federal UIC regulations by reference in Kansas Administrative Regulations (KAR) Article 28-46. ARWs also must meet the well construction requirements for the state’s water wells (KAR 28-30).

Permitting

ARWs are required to obtain a site-specific operating permit developed by the Department of Health and Environment (KDHE) Bureau of Water.

Siting and Construction

Siting is dependant on location of the contaminant plume and is reviewed by KBER. Construction logs are reviewed by KDHE. Remediation projects also must be approved by the Bureau of Environmental Remediation (KBER).

Operating Requirements

Injectates are approved on a site-by-site basis. The permit requirements may include limits on injection volume and pressure, injectate monitoring, and ground water monitoring to evaluate the migration of contaminants. Requirements are determined in conjunction with the Bureau of Environmental Remediation or Bureau of Waste Management.

Nevada

Nevada is a UIC Primacy State for Class V wells and the Division of Environmental Protection (DEP) administers the UIC program. Aquifer remediation injection wells must satisfy Nevada’s UIC program

requirements, although the statute does not specifically define ARWs as Class V wells (445A.849 NRS).

Nevada Revised Statutes (NRS) §§ 445A.300 - 445A.730 and regulations under the Nevada Administrative Code (NAC) §§ 445A.810 - 445A.925 establish the state's basic underground injection control program. The injection of fluids through a well into any waters of the state, including underground waters, is prohibited without a permit issued by DEP, (445A.465 NRS), although the statute allows both general and individual permits (445A.475 NRS and 445A.480 NRS). Furthermore, injection of a fluid that degrades the physical, chemical, or biological quality of the aquifer into which it is injected is prohibited, unless the DEP exempts the aquifer and the federal USEPA does not disapprove the exemption within 45 days after notice of it (445A.850 NRS).

Regulations, particularly Chapter 445A NAC, "Underground Injection Control," define and elaborate these statutory requirements. First, they provide that any federal, state, county, or municipal law or regulation that provides greater protection to the public welfare, safety, health, and to the ground water prevails within the jurisdiction of that governmental entity over the Chapter 445A requirements (445A.843 NAC).

Permits

The UIC regulations specify detailed information that must be provided in support of permit applications, including proposed well location, description of geology, construction plans, proposed operating data on rates and pressures of injection, analysis of injectate, analysis of fluid in the receiving formation, proposed injection procedures, and corrective action plan (445A.867 NAC). The DEP may, however, modify the permit application information required for a Class V well.

Siting and Construction

The state specifies, among other siting requirements, that the well must be sited in such a way that it injects into a formation that is separated from any USDW by a confining zone that is free of known open faults or fractures within the area of review. It must be cased from the finished surface to the top of the zone for injection and cemented to prevent movement of fluids into or between USDW (445A.908 NAC).

Operating Requirements

Monitoring frequency for injection pressure, pressure of the annular space, rate of flow, and volume of injected fluid is specified by the permit for Class V wells. Analysis of injected fluid must be conducted with sufficient frequency to yield representative data. Mechanical integrity testing is required at once each 5 years, by a specified method (445A.913.5 NAC and 445A.916 - 445A.920 NAC).

Financial Responsibility

Class V wells may be required to provide a bond in favor of the state either equal to the estimated cost of plugging and abandonment of each well or, if approved by DEP, a sum not less than \$50,000 to cover all injection wells of the permit applicant in the state (445A.871 NAC). However, if adequate proof of financial

responsibility is presented, the bonding requirements may be waived or reduced.

Plugging and Abandonment

A plugging and abandonment plan and cost estimate must be prepared for each well, and reviewed annually. Before abandonment, a well must be plugged with cement in a manner that will not allow the movement of fluids into or between USDW (445A.923 NAC).

New Hampshire

New Hampshire is a UIC Primacy State for Class V wells. Part Env-Ws 410 of the New Hampshire Administrative Code (NHAC) establishes the state's ground water protection program, which includes underground injection registration. The state has established a policy that, unless due to a natural condition or specifically exempted, all ground waters of the state shall be suitable for use as drinking water without treatment, and that ground water shall not contain any regulated contaminant at a concentration greater than the ambient ground water standards in Env-Ws 410.05 (Env-Ws 410.03 NHAC). However, the rules contain a specific exemption for a discharge from a ground water treatment system operating under and in accordance with a ground water management permit (Env-Ws 410.08(a)(7)c.(1) NHAC).

Permitting

A ground water discharge permit is required to be obtained by certain categories of discharges. However, a ground water treatment system operating under and in accordance with a ground water management permit is considered to have a permit by rule and to be exempt from the requirements of Env-Ws 410.08 (Env-Ws 410.08(a)(7)c.(6) NHAC).

To obtain a ground water management permit, an applicant must submit the following (Env-Ws 410.18 NHAC):

- C A site investigation report that defines the nature, extent, and magnitude of contamination and identifies threats to human health and the environment. The report must meet the requirements of Env-Ws 410.22. The report must be reviewed and approved by the Department of Environmental Services (DES).
- C A remedial action plan, prepared in accordance with Env-Ws 410.23 to remedy ground water contamination and restore ground water quality to meet ground water quality criteria of Env-Ws 410.03. The plan must be approved by DES.
- C Detailed permit application materials, including maps, site plans locating 16 specifically listed types of features, including ground water contours, monitoring wells, and drinking water wells.
- C All monitoring results for the past 5 years.
- C Lists of reports on land use history, water quality, and hydrogeology associated with the site.
- C A detailed proposal for a water quality monitoring program.
- C Test pit data, specified in detail.
- C Well construction details.

The requirements for the site investigation report (Env-Ws 410.22 NHAC) and the remedial action plan (Env-Ws 410.23 NHAC) are specified in substantial detail. The latter requires a description of the operational details of the remedial action, a plan of the design and construction details of the remedial system, and delineation of the ground water management, among other requirements.

Every well that injects a fluid other than wastewater is required to register the underground injection with DES. Inventory information must be supplied in the application for registration.

Ohio

Ohio is a UIC Primacy State for Class V wells. Regulations establishing the underground injection control program are found in Chapter 3745-34 of the Ohio Administrative Code (OAC).

Permitting

Class V injection well definitions do not explicitly address ARWs (3745-34-04 OAC). However, any underground injection, except as authorized by permit or rule, is prohibited. The construction of any well required to have a permit is prohibited until the permit is issued (3745-34-06 OAC).

Injection into Class V injection wells is authorized by rule (3745-34-13 OAC). However, a drilling permit and an operating permit are required for injection into a Class V injection well of sewage, industrial wastes, or other wastes, as defined in § 6111.01 of the Ohio Revised Code, into or above a USDW (3745-34-13 OAC and 3745-34-14 OAC). Therefore, if the injectate is anticipated to exceed primary drinking water standards, MCLs or Health Advisories, permits to install and operate the well will be required.

Wells required to obtain an individual permit or an area permit from Ohio must submit detailed information, including location, formation into which the well is drilled, depth of well, nature of the injectate, and a topographical map showing the facility, other wells in the area, and treatment areas (3745-34-16(E) OAC).

Siting and Construction

There are no specific regulatory requirements for the siting and construction of wells permitted by rule. Wells required to obtain an individual permit must submit siting information and construction records.

Operating Requirements

There are no specific operating or monitoring requirements for wells permitted by rule. Injectate must meet drinking water standards at the point of injection, unless a permit allows otherwise. Permitted wells will have monthly and quarterly monitoring and reporting requirements (3745-34-26 (J) OAC).

Mechanical Integrity Testing

Not specified by statute or regulation.

Financial Responsibility

Not specified by statute or regulation.

Plugging and Abandonment

Under general standards for all wells, Ohio requires plugging and abandonment.

South Carolina

South Carolina is a UIC Primacy State for Class V wells. The state's underground injection control program is implemented by the Department of Health and Environmental Control (DHEC). The UIC regulations, found in Chapter 61 of the state regulations (SCR), divide Class V wells into two groups, with ARWs, defined as "corrective action wells used to inject ground water associated with aquifer remediation," found in group (A). ((R61-87.10E.(1)(i)) The same requirements apply to ARWs as are applied to other Class V(A) wells.

Permitting

ARWs, as Class V(A) wells, are prohibited except as authorized by permit (R61-87.10.E.(2)). The permit application must include:

- C A description of the activities to be conducted.
- C The name, address, and location of the facility.
- C The names and other information pertaining to the owner and operator.
- C A description of the business, and proposed operating data, including average and maximum daily rate and volume of fluid to be injected.
- C Average and maximum injection pressure, and source and an analysis of the chemical,

- physical, biological, and radiological characteristics of the injected fluid.
- C Drawings of the surface and subsurface construction of the well (R61-87.13.G(2)).

The movement of fluids containing wastes or contaminants into USDWs as a result of injection is prohibited if the waste or contaminant may cause a violation of any drinking water standard or otherwise adversely affect the health of persons (R61-87.5).

Siting and Construction

Siting and operating criteria and standards for Class V(A) wells require logs and tests, which will be specified by DHEC in the permit, to identify and describe USDWs and the injection formation. Construction standards are the same as those applied to drinking water wells.

Injection may not commence until construction is complete, the permittee has submitted notice of completion to DHEC, and DHEC has inspected the well and found it in compliance (R61-87.13U).

Operating Requirements

DHEC will establish maximum injection volumes and pressures and such other permit conditions as necessary to assure that fractures are not initiated in the confining zone adjacent to a USDW and to assure compliance with operating requirements (R61-87.13V). Operating requirements for Class V(A) wells are not distinguished in the state regulations from operating standards for Class II and III wells (R61-87.14). Injection pressure at the wellhead may not exceed a maximum calculated to ensure that injection does not initiate new fracturing or propagate existing fractures in the confining zone adjacent to the USDW

Monitoring requirements will be specified in the permit. Monitoring requirements for Class V(A) wells are the same as those for Class III wells, and may include installation of monitoring wells in the injection zone and adjacent zones as necessary to detect the dispersion and migration of injection fluids within and from the injection zone. Monitoring of the fluid levels and water quality in the injection and monitor wells at specified intervals and submission of monitoring results will be specified in the permit. However, reporting of monitoring results to DHEC is required at least quarterly (R61-87.14.G and I(1)).

Mechanical Integrity

Prior to granting approval for operation, DHEC will require a satisfactory demonstration of mechanical integrity. Tests will be performed at least every 5 years (R61-87.14.G).

Plugging and Abandonment

A plugging and abandonment plan must be prepared and approved by DHEC (R61-87.12.B and .15).

Texas

Texas is a UIC Primacy State for Class V wells. The Injection Well Act (Chapter 27 of the Texas Water Code) and Title 3 of the Natural Resources Code provide statutory authority for the underground injection control program. Regulations establishing the underground injection control program are found in Title 30, Chapter 331 of the Texas Administrative Code (TAC).

Permitting

Underground injection is prohibited, unless authorized by permit or rule (331.7 TAC). By rule, injection into a Class V well is authorized, although the Texas Natural Resources Control Commission (TNRCC) may require the owner or operator of a well authorized by rule to apply for and obtain an injection well permit (331.9 TAC). No permit or authorization by rule is allowed where an injection well causes or allows the movement of fluid that would result in the pollution of a USDW. A permit or authorization by rule must include terms and conditions reasonably necessary to protect fresh water from pollution (331.5 TAC). ARWs are not specifically defined as Class V wells, but the regulations state that Class V wells inject non-hazardous fluids into or above formations that contain USDWs, and that the Class V wells are not limited to listed categories (331.11 (a)(4) TAC).

Siting and Construction

All Class V wells are required to be completed in accordance with explicit specifications in the rules, unless otherwise authorized by the TNRCC. These specifications are:

- C A form provided either by the Water Well Drillers Board or the TNRCC must be completed;
- C The annular space between the borehole and the casing must be filled from ground level to a depth of not less than 10 feet below the land surface or well head with cement slurry. Special requirements are imposed in areas of shallow unconfined ground water aquifers and in areas of confined ground water aquifers with artesian head.
- C In all wells where plastic casing is used, a concrete slab or sealing block must be placed above the cement slurry around the well at the ground surface; and the rules include additional specifications concerning the slab;
- C In wells where steel casing is used, a slab or block will be required above the cement slurry, except when a pit-less adaptor is used, and the rules contain additional requirements concerning the adaptor;
- C All wells must be completed so that aquifers or zones containing waters that differ significantly in chemical quality are not allowed to commingle through the borehole-casing annulus or the gravel pack and cause degradation of any aquifer zone;
- C The well casing must be capped or completed in a manner that will prevent pollutants from entering the well; and
- C When undesirable water is encountered in a Class V well, the undesirable water must be sealed off and confined to the zone(s) of origin (331.132 TAC).

Operating Requirements

None specified. Chapter 331, Subpart H, “Standards for Class V Wells” addresses only construction and closure standards (331.131 to 331.133 TAC).

Mechanical Integrity Testing

Injection may be prohibited for Class V wells that lack mechanical integrity. The TNRCC may require a demonstration of mechanical integrity at any time if there is reason to believe mechanical integrity is lacking. The TNRCC may allow plugging of the well or require the permittee to perform additional construction, operation, monitoring, reporting, and corrective actions which are necessary to prevent the movement of fluid into or between USDW caused by the lack of mechanical integrity. Injection may resume on written notification from the TNRCC that mechanical integrity has been demonstrated (331.4 TAC).

Financial Responsibility

Chapter 27 of the Texas Water Code, “Injection Wells,” enacts financial responsibility requirements for persons to whom an injection well permit is issued. A performance bond or other form of financial security may be required to ensure that an abandoned well is properly plugged (§ 27.073). Detailed financial responsibility requirements also are contained in Chapter 331, Subchapter I of the state’s UIC regulations (331.141 to 331.144 TAC). A permittee is required to secure and maintain a performance bond or other equivalent form of financial assurance or guarantee to ensure the closing, plugging, abandonment, and post-closure care of the injection operation. However, the requirement, unless incorporated into a permit, applies specifically only to Class I and Class III wells (331.142 TAC).

Plugging and Abandonment

Plugging and abandonment of a well authorized by rule is required to be accomplished in accordance with §331.46 TAC (331.9 TAC). In addition, closure standards specific to Class V wells provide that closure is to be accomplished by removing all of the removable casing and filling the entire well with cement to land surface. Alternatively, if (1) the use of the well to be permanently discontinued, and (2) the well does not contain undesirable water, the well may be filled with fine sand, clay, or heavy mud followed by a cement plug extending from the land surface to a depth of not less than 10 feet. If the use of a well that does contain undesirable water is to be permanently discontinued, either the zone(s) containing undesirable water or the fresh water zone(s) must be isolated with cement plugs and the remainder of the well boring filled with sand, clay, or heavy mud to form a base for a cement plug extending from the land surface to a depth of not less than 10 feet (331.133 TAC).

REFERENCES

Allen, Robert. 1999. Water Division, Department of Pollution Control, Arkansas. Telephone communication with Jia Li, ICF Inc. April 26, 1999.

Alabama Department of Environmental Management (ADEM). 1998. Class V Underground Injection Control Permit No. ALSI9902355, issued by the Alabama Department of Environmental Management to the Utilities Board of the City of Bay Minette, Alabama. September 9, 1998.

Arizona Department of Environmental Quality (ADEQ). 1998. Best Available Demonstrated Control Technology (BADCT) Guidance Document for Domestic and Municipal Wastewater Treatment, Draft. Water Quality Division, Aquifer Protection Program.

Agency for Toxic Substances and Disease Registry (ATSDR). 1999. Public Health Statements. Atlanta, GA: Agency for Toxic Substances and Disease Registry, Division of Toxicology. Available: <http://www.atsdr.cdc.gov/ToxProfiles> [April, 1999]

Borden, R.C., R.T. Goin, C-M. Kao, C.G. Rosal. 1996. Enhanced Bioremediation of BTEX Using Immobilized Nutrients: Field Demonstration and Monitoring (Project Summary). U.S. Environmental Protection Agency, National Exposure Research Laboratory, EPA/600/SR-96/145. December 1996.

Brigmon, R.L. et. al. 1998. Evaluation of Methanotrophic Bacteria during Injection of Gaseous nutrients for In Situ Trichloroethylene Bioremediation in a Sanitary Landfill, 1998. Westinghouse Savannah River Company Report WSRC-MS-98-00854, 1998. Published at WSRC Internet site <http://www.srs.gov/general/sci-tech/fulltext/ms9800854/ms9800854.html>

California Regional Water Quality Control Board (CRWQCB). 1999. Waste Discharge Requirements for Coast Wood Preserving Inc. CRWQCB North Coast Region. Order No.99 ID No. IB235004224.

The Cadmus Group. 1999. State-by-State Notebooks Compiling Results from the Class V Underground Injection Control Study. February 1, 1999.

Chapman, S.W., B.T. Byerley, D.J.A. Smyth, D.M. Mackay. 1997. A Pilot Test of Passive Oxygen Release for Enhancement of In Situ Bioremediation of BTEX-Contaminated Ground Water, Ground Water Monitoring and Remediation (Spring 1997), p.93-105.

CH2MHILL (No date). Technology Practices Manual for Surfactants and Cosolvents, [Online]. Available at: <http://www.clu-in.com/aatdf/toc.htm> [1997, February].

Chapman, S.W., B.T. Byerley, D.J.A. Smyth, D.M. Mackay. 1997. A Pilot Test of Passive Oxygen Release for Enhancement of In Situ Bioremediation of BTEX-Contaminated Ground Water, Ground Water Monitoring and Remediation (GWMR), Spring 1997, p.93-105.

Civil Engineering. 1998. Air Force Tests Bioremediation Bugs. 63(3): 10-11.

City of Bay Minette Utilities Board. 1999. Letter from Mr. Harry Still, Jr., General Manager of Utilities Board of the City of Bay Minette, Alabama, to Mr. Scott Hughes, Alabama Department of Environmental Management, Groundwater Division, Re: UIC Permit Number ALSI 99902355 Monthly Monitoring Report. February 26, 1999.

Cline, S.R., O.R. West, R.L. Siegrist, W.L. Holden. 1997. Performance of in situ chemical oxidation field demonstrations at DOE sites, in the proceedings of the ASCE Geoenvironmental Conference, Special Publication No. 71, Minneapolis MN. October 5, 1997.

Cochran, M. 1999. Regional/state comments on the draft of the Aquifer Remediation Wells Information Summary dated May 14, 1999. KS Department of Health & Environment.

Dablow, J., R. Hicks, D. Cacciatore. 1995. Steam Injection and Enhanced Bioremediation of Heavy Fuel Oil Contamination. Applied Bioremediation of Petroleum Hydrocarbons, Conference Title: 3 International In Situ and on Site Bioreclamation Symposium, April 24-27, 1995. Bioremediation. 3(6):115-121.

Dahab, M.F., P.Y. Lee. 1992. Nitrate Reduction by In-Situ Bio-denitrification in Ground water. Wat.Sci.Tech. 26(7-8):1493-1502.

Davis, E.L. 1998a. Steam Injection for Soil and Aquifer Remediation. (Ground Water Issue). U.S. Environmental Protection Agency, Office of Research and Development, Office of Solid Waste and Emergency Response. EPA/540/S97/505. January 1998.

Davis, E.L. 1998b. Dynamic Underground Stripping for Creosote Removal, [Online]. U.S. Environmental Protection Agency, Solid Waste and Emergency Response. Ground Water Currents, Issue No.28. EPA/542/N98/006. Available: <http://clu-in.com/gwc/gwccurre.htm> [1998, July 1].

Devlin, Rob. 1999a. Ground Water Protection Division, South Carolina Department of Health & Environmental Control (SCDHEC). Telephone communication with Jia Li, ICF Incorporated. April 21, 1999.

Devlin, Rob. 1999b. Ground Water Protection Division, SCDHEC. Telephone communication with Jia Li, ICF Consulting. August 2, 1999.

Duba, A.G., K.J. Jackson, M.C. Jovanovich, R.B. Knapp, R.T. Taylor. 1996. TCE Remediation Using In Situ, Resting-State Bioaugmentation. Environ. Sci. Technol. 30(6):1982-1989. June 1996.

Environmental Engineering World. 1995. In Situ Process Converts Toxic Cr⁺⁶ to Non-tox Cr⁺³. 1(2): 38-39.

Eyster, Richard. 1999a. Texas Natural Resource Conservation Commission (TNRCC). Telephone conversation with Jia Li, ICF Inc. April 28, 1999.

- Eyster, Richard. 1999b. TNRCC. Telephone communication with Jia Li, ICF Consulting. August 3, 1999.
- Federal Remediation Technologies Roundtable (FRTR). 1997. Remediation Technologies Screening Matrix and Reference Guide, Version 3.0. Available: <http://www.frtr.gov>
- FRTR, 1995. Remediation Case Studies: Ground water Treatment. U.S. Environmental Protection Agency. EPA/542/R95/003.
- Hazen, T.C., B.B. Looney, M. Enzien, M.M. Franck, C.B. Fliermans, C.A. Eddy. 1993. In Situ Bioremediation Via Horizontal Wells. Conference Title: Symposium on engineering hydrology, San Francisco, CA, July 25-30, 1993, p. 862-867.
- Hightower, M. 1998. In Situ Steam Stripping and Bioremediation Used in Shallow Media at Pinellas. U.S. Environmental Protection Agency, Solid Waste and Emergency Response. Ground Water Currents, Issue No.28. EPA/542/N98/006. Available: <http://clu-in.com/gwc/gwccurre.htm> [1998, July 1].
- Hooker, B.S., R.S. Skeen, M.J. Truex, B.M. Peyton. 1994. A demonstration of in-situ bioremediation of CCl_4 at the Hanford Site. Conference title: 33. Hanford symposium on health and the environment: symposium on it-situ remediation—scientific basis for current and future technologies, Nov. 7-11, 1994, p. 281-292.
- Howard, P.H., R.S. Boethling, W.F. Jarvis, W.M. Meylan, E.M. Michalenko. 1991. Handbook of Environmental Degradation Rates. Lewis Publishers.
- Interstate Technology and Regulatory Cooperation (ITRC). 1998. Technical and Regulatory Requirements for Enhanced In Situ Bioremediation of Chlorinated Solvents in Groundwater. ITRC Work Group, In Situ Bioremediation Work Team. December 23, 1998.
- Jafvert, C. 1996. Surfactants/ Cosolvents (Technology Evaluation Report). Ground-Water Remediation Technologies Analysis Center. TE-96-02. December 1996.
- Jerome, K. 1997. In Situ Oxidation Destruction of DNAPL. Ground Water Currents, No.25. U.S. Environmental Protection Agency, Solid Waste and Emergency Response. EPA/542/N97/004. Available: <http://www.clu-in.com/gwc/gwc1.htm#August 1997> [1997 September].
- Knox, R.C., D.A. Sabatini, J.H. Harwell, R.E. Brown, C.C. West, F. Blaha, C. Griffin. 1997. Surfactant remediation field demonstration using a vertical circulation well. Ground Water. 30(6): 948-953.
- Leethem, J.T., R.E. Beeman, M.D. Lee, A.A. Biehle, D.E. Ellis, S. Shoemaker. 1995. Anaerobic In Situ Bioremediation: Injected Nutrient and Substrate Fate and Transport. Applied Bioremediation of Petroleum Hydrocarbons, Conference Title: 3 International In Situ and on Site Bioreclamation Symposium, April 24-27, 1995, Bioremediation. 3(6): 271-280.

Lesage, S., S. Brown, K. Millar. 1996. Vitamin B₁₂-Catalyzed Dechlorination of Perchloroethylene Present as Residual DNAPL. *GWMR*. 16(4): 76-85.

Lucht, Robert. 1999a. Water Division, Department of Environmental Quality, Wyoming. Telephone conversation with Jia Li, ICF Inc. April 23, 1999.

Lucht, Robert. 1999b. Water Division, Department of Environmental Quality, Wyoming. Telephone conversation with Alejandro Fernández, ICF Inc. September 22, 1999.

Martel, R., P.J. Gélinas, L. Saumure. 1998. Aquifer Washing by Micellar Solutions: 3 Field Test at the Thouin Sand Pit (L'Assomption, Québec, Canada). *J. of Contam. Hydrology*. 30:33-48.

McCarty, P.L. 1997. Biodegradation of TCE through Toluene Injection. *Ground Water Currents*. No.25. U.S. Environmental Protection Agency, Solid Waste and Emergency Response. EPA/542/N97/004. Available: <http://www.clu-in.com/gwc/gwc1.htm#August 1997> [1997, September].

McCarty, P.L., M.N. Goltz, G.D. Hopkins, M.E. Dolan, J.P. Allan, B.T. Kawakami, T.J. Carrothers. 1998. Full-Scale Evaluation of In Situ Cometabolic Degradation of Trichloroethylene in Ground water through Toluene Injection. *Environ. Sci. Technol.* 32(1):88-100.

McCaulou, D.R., D.G. Jewett, S.G. Huling. 1995. Nonaqueous Phase Liquids Compatibility with Materials Used in Well Construction, Sampling, and Remediation. U.S. Environmental Protection Agency, Office of Research and Development, Office of Solid Waste and Emergency Response. EPA/540/S95/503. July 1995.

McCaulou, D.R., D.G. Jewett, S.G. Huling. 1996. Compatibility of NAPLs and Other Organic Compounds with Materials Used in Well Construction, Sampling, and Remediation. *GWMR*. Fall 1996.

McCaulou, D.R., S.G. Huling. 1999. Compatibility of Bentonite and DNAPLs. *GWMR*. Spring 1999. Page 78-86.

Micham, Ross. 1999a. Responses to Peer Review. Change for Class V UIC Study, Aquifer Remediation Wells: Information Summary dated May 16, 1999. USEPA Region 5 UIC Program.

Micham, R. 1999b. Telephone conversation with Jia Li, ICF Inc. April 26, 1999. USEPA Region 5 UIC Program.

Micham, R. 1999c. Telephone communication with Jia Li, ICF Consulting. July 29, 1999. USEPA Region 5 UIC Program.

Micham, R. 1999d. Responses to Peer Review. Change for Class V UIC Study, Experimental Technology Wells: Information Summary dated May 16, 1999. USEPA Region 5 UIC Program.

Millar, K., S. Lesage. 1997. Bio-compatibility of the Vitamin B₁₂-catalyzed Reductive Dechlorination of Tetrachloroethylene. The Fourth International In Situ and On-Site Bioremediation Symposium. New Orleans. April 28-May 1, 1997.

Miller, R.R. 1996a. Horizontal Wells. Ground-Water Remediation Technologies Analysis Center. Technology Overview Report TO-96-02. October 1996.

Miller, R.R. 1996b. Air Sparging. Ground-Water Remediation Technologies Analysis Center. Technology Overview Report TO-96-04. October 1996.

Morin, T.C. 1997. Field Results on the Use of Solid-Phase Oxygen Supplementation Compounds to Accelerate Intrinsic Biodegradation of GRO and BTEX in a High K Aquifer. Kennedy/ Jenks Consultants. Proceedings of the Petroleum Hydrocarbons and Organic Chemicals in Ground Water--Prevention, Detection, and Remediation Conference: Nov. 12-14, 1997, Houston, TX. pp. 683-691. Series: Ground water management, Ground Water Publishing Co. 1997.

National Research Council (NRC). 1980. Drinking Water and Health. Volume 3. Washington, DC: National Academy Press. 3: 278-279.

NRC. 1994. Alternatives for Ground Water Cleanup. National Academy Press, Washington, D.C.

NRC. 1997. Innovations in Ground Water and Soil Cleanup: From Concept to Commercialization. National Academy Press. Washington, D.C.

North Carolina Department of Environment and Natural Resources (NCDENR). 1999. Application for Permit to Construct and Use a Well for Injection (Class 5). Submitted to the NCDENR Underground Injection Program by Dr. Robert C. Borden, North Carolina State University, June 1, 1998.

Nyer, E.K., S. Suthersan. 1996. In Situ Reactive Zones. GWMR. 16(3): 70-75.

Piotrowski, M.R. 1992. In Situ Aquifer Treatments. Environmental Protection. 3(4):34, 36-38, 49.

Puls, R.W., R.M. Powell. July 1997. Permeable Reactive Subsurface Barriers for the Interception and Remediation of Chlorinated Hydrocarbon and Chromium(VI) Plumes in Ground Water. U.S. Environmental Protection Agency, National Risk Management Research Laboratory, EPA/600/F-97/008.

Remediation Technologies Development Forum (RTDF). 1997. Summary of the Remediation Technologies Development Forum *In Situ* Flushing Action Team Meeting. RTDF In Situ Flushing Action Team. Hill Air Force Base, Utah. May 8-9, 1997., Available: <http://www.rtdf.org/public/flushing/minutes/Isf0597.htm> [1998, August 10].

RTDF Permeable Reactive Barriers Action Team, 1998a. LEAP Permeable Barrier Demonstration Facility, Portland, OR. Available at <http://rtdf.org/PRBSUMMS/Leapnm.htm> [Sept.2, 1998]

RTDF Permeable Reactive Barriers Action Team, 1998b. Nickel Rim Mine Site, Sudbury, Ontario Canada. Available at <http://rtdf.org/PRBSUMMS/Sudbury.htm> (Sept.2, 1998)

RTDF Permeable Reactive Barriers Action Team, 1998c. Summary of the Remediation Technologies Development Forum, Steering Committee Conference Call, 11:30A.M.-1:00P.M. June 1. Available: <http://www.rtdf.org>

Rhue, R.D., M.D. Annable, P.S.C. Rao. 1998. Lab and Field Evaluation of Single-Phase Microemulsions for Enhanced In-Situ Remediation of Contaminated Aquifers. Available: <http://www.ruf.rice.edu/~aatdf/pages/spme.htm> [1998, September 2].

Roote, D.S. 1997. In Situ Flushing (Technology Overview Report). Ground-Water Remediation Technologies Analysis Center, TO-97-02.

Roote, D.S. 1998. Featured Technology Summary Report In Situ Flushing August 7, 1998 (Information Report). Ground-Water Remediation Technologies Analysis Center. TI-98-01.

Sabatini, D.A., R.C. Knox, J.H. Harwell. August 1996. Surfactant-Enhanced DNAPL Remediation: Surfactant Selection, Hydraulic Efficiency, and Economic Factors (Environmental Research Brief). U.S. Environmental Protection Agency, National Risk Management Research Laboratory, EPA/600/S-96/002.

Sabatini, D.A., R.C. Knox, E.E. Tucker, R.W. Puls. 1997. Innovative Measures for Subsurface Chromium Remediation: Source Zone, Concentrated Plume, and Dilute Plume. EPA Environmental Research Brief. EPA/600/S-97/005. September 1997.

Scalzi, M. 1992. Bioremediation can produce predictable, reproducible results. Soil & Ground water Cleanup. Available: <http://www.sgcleanup.com/bio/biorem.html> [1998, Sept.15]

SECOR International Incorporated, 1999. Letter from Mr. Scott D. Andrews, P.E., Project Manager, SECOR International Incorporated, to Mr. Bob Becker, USEPA Region 8, Underground Injection Control Program, Re: Notification of Initiation of Hydrofracture Test Activities, Material Testing Laboratory Project, CDOT Headquarters, Denver, Colorado, March 19, 1999.

Sewell, G.W., M.F. DeFlaun, N.H. Baek, E. Lutz, B. Weesner, B. Mahaffey. 1998. Performance Evaluation of an In Situ Anaerobic Biotreatment System for Chlorinated Solvents. U.S. Environmental Protection Agency, National Risk Management Research Laboratory, EPA/600/A98/041.

Sims, J.L., J.M. Suflita, H.H. Russell. 1992. In-Situ Bioremediation of Contaminated Ground Water (Ground Water Issue). U.S. Environmental Protection Agency, Office of Research and Development, Office of Solid Waste and Emergency Response, EPA/540/S92/003. February 1992.

Slosky & Company. 1998. Letter from Michael J. Galloway, P.G., Senior Hydrologist, Slosky & Company,

Inc., to Ms. Valois Shea-Albin, USEPA Region 8, Underground Injection Control, Re: Class V Underground Injection on Behalf of Power Engineering Company, Denver, Colorado, December 15, 1998.

Sorel, M., J.A. Cherry, S. Lesage. 1998. In Situ Vertical Circulation Column: Contaminant System for Small-Scale DNAPL Field Experiments. GWMR. Winter 1998.

Stevens Point Water and Sewage Treatment Department (SPWSTD). 1998. Letter from Mr. Gregory R. Disher, Administrator, Stevens Point Water and Sewage Treatment Department, to Mr. Richard Roth, Wisconsin Department of Natural Resources, Bureau of Drinking Water and Groundwater, Re: University of Wisconsin Stevens Point Proposal for Groundwater Manganese Remediation Testing, June 10, 1998.

Sutfin, J.A., D. Ramey. 1997. In Situ Biological Treatment of TCE-Impacted Soil and Ground water: Demonstration Results. Environmental Progress. 16(4):287-296.

U. S. Department of Defense (USDOD). 1998. Letter to Mr. Ron Zbyd, USEPA, Region 8, from Phillip M. Mayer, Acting Director, Environmental Management, Pueblo Chemical Depot, Department of the Army. Subject: Quarterly Underground Injection Control Report for the Landfill Area – Ground Water Remediation System, Pueblo Depot Activity, Pueblo, Colorado (EPA File #CO5000-03986). August 4, 1998.

U.S. Department of Energy (USDOE). 1995. Office of Environmental Management, Office of Technology Development. In Situ Bioremediation Using Horizontal Wells. Innovative Technology Summary Report. Available: <http://www.em.doe.gov/plumesfa/intech/isbuhw/index.html>.

U.S. Environmental Protection Agency (USEPA). 1984. National Secondary Drinking Water Regulations. Publication No. EPA 570/9-76-000.

USEPA. 1986. *Quality Criteria for Water*. Washington, DC: Office of Water. EPA 440/5-86-001.

USEPA. 1987. Office of Water. September 1987. Report to Congress: Class V Injection Wells. EPA 570/987/006.

USEPA. 1998. National secondary drinking water regulations. 40 CFR §143.

USEPA. 1992. Integrated Risk Information System (IRIS) Background Document 4: USEPA Regulatory Action Summaries. Cincinnati, OH: Office of Research and Development. January 1992.

USEPA. 1994. Office of Solid Waste And Emergency Response. How To Evaluate Alternative Cleanup Technologies At Underground Storage Tank Sites. EPA 510/B94/003. March 1994.

USEPA. 1995. *Ecological Restoration: A Tool To Manage Stream Quality*. Washington, DC: Office of Water. EPA 841/F-95-007. Available at: <http://www.epa.gov/OWOW/NPS/Ecology/>

USEPA. 1995a. Office of Solid Waste and Emergency Response, Technology Innovation Office. Surfactant Injection for Ground Water Remediation: State Regulators' Perspectives and Experiences. EPA 542-R-95-011. December 1995.

USEPA. 1995b. Manual: Bioventing Principles and Practice. USEPA, Office of Research and Development. Washington, D.C. September 1995.

USEPA. 1996. Drinking Water Regulations and Health Advisories. Office of Water. EPA 822-B-96-002.

USEPA. 1996a. Office of Research and Development, National Risk Research Laboratory. Pump and Treat Ground-Water Remediation: A Guide for Decision Makers and Practitioners. EPA 625/R95/005. July 1996.

USEPA. 1996b. Technology Innovation Office. State Policy and Regulatory Barriers to In Situ Ground Water Remediation. EPA/542/R-96/001. March 1996.

USEPA. 1996c. Office of Solid Waste and Emergency Response, Technology Innovation Office. Summary of the August 1996 Meeting of the Bioremediation Action Committee. Available at: <http://www.clu-in.com/bac.htm> [1998, September 2].

USEPA. 1997a. Office of Research and Development, Office of Solid Waste and Emergency Response. How Heat Can Enhance In-Situ Soil and Aquifer Remediation: Important Chemical Properties and Guidance on Choosing the Appropriate Technique. EPA/540/S-97/502. April 1997.

USEPA. 1997b. Technology Innovative Office. Vendor Information System for Innovative Treatment Technologies. VISITT Database. Version 6.0. Available: <http://www.clu-in.com/> [December 1997]

USEPA. 1998. National Secondary Drinking Water Regulations. 40 CFR § 143.

USEPA, Region 8, 1998b. Situation Statement, UIC Class V Injection Well, Ground Water Remediation Injection Well, Rule Authorization, Mustang-Shadow Mountain Gas Station (EPA File #CO5000-03793). June 9, 1998.

USEPA. 1999. Drinking Water Regulations and Health Advisories. Publication No. EPA-822-b-96-002. October 1996. Available at: <http://www.epa.gov/OST/Tools/dwstds.html> (1999).

USEPA. 1999. Integrated Risk Information System (IRIS). Cincinnati, OH: Office of Research and Development, National Center for Environmental Assessment. Available: <http://www.epa.gov/ngispgm3/iris/index.html> [April, 1999]

USEPA. 1999a. Integrated Risk Information System (IRIS). Cincinnati, OH: Office of Research and Development, National Center for Environmental Assessment. Available: <http://www.epa.gov/ngispgm3/iris/index.html> [March, 1999]

USEPA. 1999b. National Primary Drinking water Regulations Technical Fact Sheets. Washington, D.C.: Office of Water, Office of Ground Water and Drinking Water. Available at: <http://www.epa.gov/OGWDW/hfacts.html> [March, 1999].

USEPA Region 8. 1999. State/Regional comments on the May 16 draft of the Experimental Technology Wells report.

U.S. Geological Survey (USGS). 1996a. Letter from Mr. Peter B. McMahon, Ph.D., Hydrologist, USGS Water Resources Division, Colorado District, to Mr. Ronald Zdyb, U.S. Environmental Protection Agency. July 28, 1996.

University of Wisconsin, Stevens Point (UWSP). 1999. Personal Communication between Professor Byron Shaw, University of Wisconsin at Stevens Point, and Mr. Michael Browning, ICF Inc. March 23, 1999.

Victor, W.R. 1998. Errol L. Montgomery & Associates, Inc. Assessment of Potential Impact of Blower Failure Groundwater Remediation system Hassayampa Landfill EPA Superfund Site. A letter addressed to Nadia Hollan (SFD-7-11), Remedial Project Manager, USEPA. March 23, 1998.

Vidic, R.D., F.G. Pohland. 1996. Treatment Walls (Technology Evaluation Report). Ground-Water Remediation Technologies Analysis Center. TE-96-01. October 1996.

Williams, Jonathan. 1999. USEPA Region 10. Telephone conversation with Jia Li, ICF Consulting. August 3, 1999.

Wisconsin Department of Natural Resources (WDNR). 1998. Letter from Mr. William T. Rock, P.E., Chief, Private Water Systems Section, Wisconsin Department of Natural Resources, Bureau of Drinking Water and Groundwater, to Mr. Gregory R. Disher, Administrator, Stevens Point Water and Sewage Treatment Department, Subject: Approval for underground injection of Oxygen Releasing Compound and sodium hypochlorite for the purpose of performing in-situ manganese reduction demonstration testing in the area of the Stevens Point Municipal Wellfield, June 30, 1998.

Zhu, H.K., L. Guanghe, L. Zhaochang. 1998. In Situ Remediation Of Petroleum Compounds In Ground water Aquifer With Chlorine Dioxide. *Water. Res.* 32(5):1471-1480.