

United States
Environmental Protection
Agency

Office of Water Regulations
and Standards (WH-552)
Industrial Technology Division
Washington, DC 20460

EPA 440/1-89-019.1
May 1989



Office of Water

Development **FINAL**
Document for
Effluent Limitations
Guidelines and
Standards for the
Nonferrous Metals
Manufacturing
Point Source
Category

Volume I
General

Printed on Recycled Paper

ORGANIZATION OF THIS DOCUMENT

This development document for the nonferrous metals manufacturing category consists of a general development document which considers the general and overall aspects of the regulation and 31 subcategory specific supplements. These parts are organized into 10 volumes as listed below.

The information in the general document and in the supplements is organized by sections with the same type of information reported in the same section of each part. Hence to find information on any specific aspect of the category one would need only look in the same section of the general document and the specific supplements of interest.

The ten volumes contain contain the following subjects:

- Volume I General Development Document
- Volume II Bauxite Refining
 Primary Aluminum Smelting
 Secondary Aluminum Smelting
- Volume III Primary Copper Smelting
 Primary Electrolytic Copper Refining
 Secondary Copper Refining
 Metallurgical Acid Plants
- Volume IV Primary Zinc
 Primary Lead
 Secondary Lead
 Primary Antimony
- Volume V Primary Precious Metals and Mercury
 Secondary Precious Metals
 Secondary Silver
 Secondary Mercury
- Volume VI Primary Tungsten
 Secondary Tungsten and Cobalt
 Primary Molybdenum and Rhenium
 Secondary Molybdenum and Vanadium
- Volume VII Primary Beryllium
 Primary Nickel and Cobalt
 Secondary Nickel
 Secondary Tin
- Volume VIII Primary Columbium and Tantalum
 Secondary Tantalum
 Secondary Uranium
- Volume IX Primary and Secondary Titanium
 Primary Zirconium and Hafnium
- Volume X Primary and Secondary Germanium and Gallium
 Primary Rare Earth Metals
 Secondary Indium

DEVELOPMENT DOCUMENT
for
EFFLUENT LIMITATIONS GUIDELINES AND STANDARDS
for the
NONFERROUS METALS MANUFACTURING POINT SOURCE CATEGORY

Volume I

General Development Document

William K. Reilly
Administrator

Rebecca Hanmer
Acting Assistant Administrator for Water

Martha G. Prothro, Director
Office of Water Regulations and Standards



Thomas M. O'Farrell, Director
Industrial Technology Division

Ernst P. Hall, P.E., Chief
Metals Industry Branch
and
Technical Project Officer

May 1989

U.S. Environmental Protection Agency
Office of Water
Office of Water Regulations and Standards
Industrial Technology Division
Washington, D.C. 20460

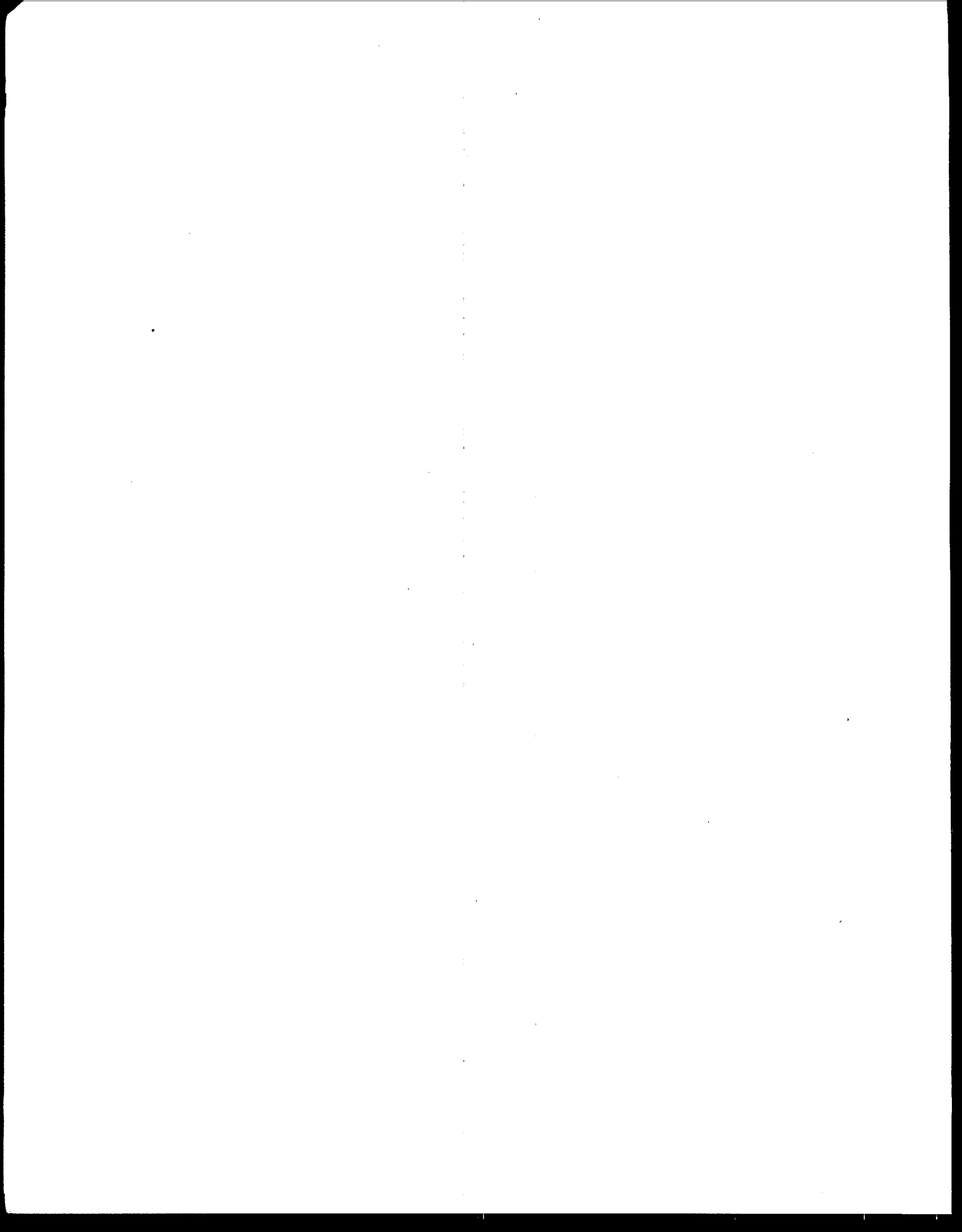

GENERAL DEVELOPMENT DOCUMENT

FOREWORD

This foreword briefly describes the recent history of regulations promulgated for this category and the litigation and subsequent settlement agreements resulting from promulgation of the rulemakings.

Revised and expanded effluent limitations and standards for the Nonferrous Metals Manufacturing Point Source Category were promulgated in two separate rulemakings, sometimes referred to as Phase I and Phase II. The category was divided into two phases for regulatory convenience; this division was generally consistent with Agency priorities of regulating first those segments which generate the largest quantities of toxic pollutants. The two finalized rulemakings and the three minor amendments derived from settlement agreements are integral parts of one regulation (40 CFR Part 421).

The Agency used the same overall approach in the development of each rulemaking, however, certain assumptions were made specific to each of the two phases. These assumptions, which are described in this document, were based on the best data available to EPA at the time each phase was developed.

EPA promulgated amendments to the nonferrous metals manufacturing category (Phase I) on March 8, 1984 (49 FR 8742). Twelve subcategories were addressed at that time:

1. Primary Aluminum Smelting
2. Secondary Aluminum Smelting
3. Primary Copper Smelting
4. Primary Copper Electrolytic Refining
5. Secondary Copper
6. Primary Lead
7. Primary Zinc
8. Metallurgical Acid Plants
9. Primary Tungsten
10. Primary Columbium-Tantalum
11. Secondary Silver
12. Secondary Lead

On September 20, 1985, EPA promulgated additional amendments for the nonferrous metals manufacturing category (Phase II) (50 FR 38276). Twenty-five subcategories were addressed in this amendment.

1. Bauxite Refining
2. Metallurgical Acid Plants (Molybdenum)
3. Primary Antimony
4. Primary Beryllium
5. Primary Boron
6. Primary Cesium and Rubidium
7. Primary and Secondary Germanium and Gallium
8. Secondary Indium
9. Primary Lithium

GENERAL DEVELOPMENT DOCUMENT

10. Primary Magnesium
11. Secondary Mercury
12. Primary Molybdenum and Rhenium
13. Secondary Molybdenum and Vanadium
14. Primary Nickel and Cobalt
15. Secondary Nickel
16. Primary Precious Metals and Mercury
17. Secondary Precious Metals
18. Primary Rare Earth Metals
19. Secondary Tantalum
20. Secondary Tin
21. Primary and Secondary Titanium
22. Secondary Tungsten and Cobalt
23. Secondary Uranium
24. Secondary Zinc
25. Primary Zirconium and Hafnium

After publication of the March 1984 amendments, twelve petitioners filed petitions for judicial review of the regulation. These challenges were consolidated into one lawsuit by the United States Court of Appeals for the Fourth Circuit (Kennecott v. EPA, 4th Cir. No. 84-1288 and Consolidated Cases). On December 26, 1985 the court denied the petitions for review of the primary lead, primary zinc, primary copper, metallurgical acid plants, secondary lead and the columbium-tantalum subcategories (780 F. 2d 445). The United States Supreme Court denied two petitions for a writ of certiorari on October 7, 1986.

In November, 1985 four aluminum parties in the consolidated lawsuits entered into two settlement agreements which resolved issues raised by the petitioners related to the primary and secondary aluminum subcategories. In accordance with the Settlement Agreements, EPA published a notice of proposed rulemaking on May 20, 1986 and solicited public comments on these proposed amendments to 40 CFR Part 421 (50 FR 18530). EPA promulgated these amendments (primary and secondary aluminum subcategories) on July 7, 1987 (52 FR 25552).

On June 26, 1986 EPA entered into a Settlement Agreement with AMAX, Inc. and intervenor GTE Products Corp., two petitioners affected by the regulations for the Primary Tungsten Subcategory. As a result of the settlement agreement, EPA proposed amendments to the Primary Tungsten Subcategory regulation on January 20, 1987 (52 FR 2480). After considering public comments on this proposal, EPA promulgated these amendments on January 21, 1988 (53 FR 1704).

Ten petitioners challenged the September 1985 (Phase II) amendments. The Agency has developed settlement agreements resolving the complaints of six petitioners; three petitioners have withdrawn their complaints and one complaint was made moot when the Agency withdrew the BPT and BAT limitations for one subcategory (primary rare earth metals). These settlement agreements are the basis for amendments proposed April 28, 1989 (54FR18412).

GENERAL DEVELOPMENT DOCUMENT

The five amendments of greatest significance to this document are:

<u>Proposal</u>	<u>Promulgation</u>
February 17, 1983 (48FR7032)	March 8, 1984 (49FR 8742)
June 27, 1984 (49FR26352)	September 20, 1985 (50FR38276)
May 20, 1986 (50FR18530)	July 7, 1987 (52FR25552)
January 20, 1987 (52FR2480)	January 21, 1988 (53FR1704)
April 28, 1989 (54FR18412)	

In the preparation of this document, including the supplements, the administrative records or court dockets have been used as the primary source of data and information. Obvious errors have been corrected and some substantial editing has been performed in some areas, especially where it was necessary to protect information claimed to be confidential by the firm that originally made the information available. Additionally, supplements which were originally prepared to support the March 8, 1984 and September 20, 1985 promulgations have been edited to reflect the most recent amendments to the regulation. The supplements have also been updated to reflect amendments to the regulations that would be effective if the April 1989 proposed amendments are promulgated without change.

The Agency has not substantially updated the information about specific plants or processes. It is recognized that much of the information was collected in the 1979 to 1983 period and that time may have allowed changes to creep into the data. This is unavoidable and should be taken into account when the data and information are being used for some purposes. For most uses, the data should be completely useful as it defines and clarifies the technical basis for the nonferrous metals manufacturing effluent limitations and standards.

In providing this technical basis for the regulation, the Agency believes that it will be useful to industry and permit writing authorities alike as it provides the best technical advice relative to the effluent standards and limitations. In an effort to provide this advice, the Agency has included a substantial amount of technical data about the processes and raw wastewaters within the processes. Where this data was available to the Agency but is not provided, it has been withheld because of claims of confidentiality. Additionally, where there were pollutants found but not specifically regulated, the levels at which they would have been regulated are shown to permit a ready technical evaluation in situations where wastewater streams from different categories or subcategories are combined for treatment and discharge.

Questions, comments, and corrections for this document may be addressed to The Environmental Protection Agency, Industrial Technology Division (WH552), Washington, DC 20460.

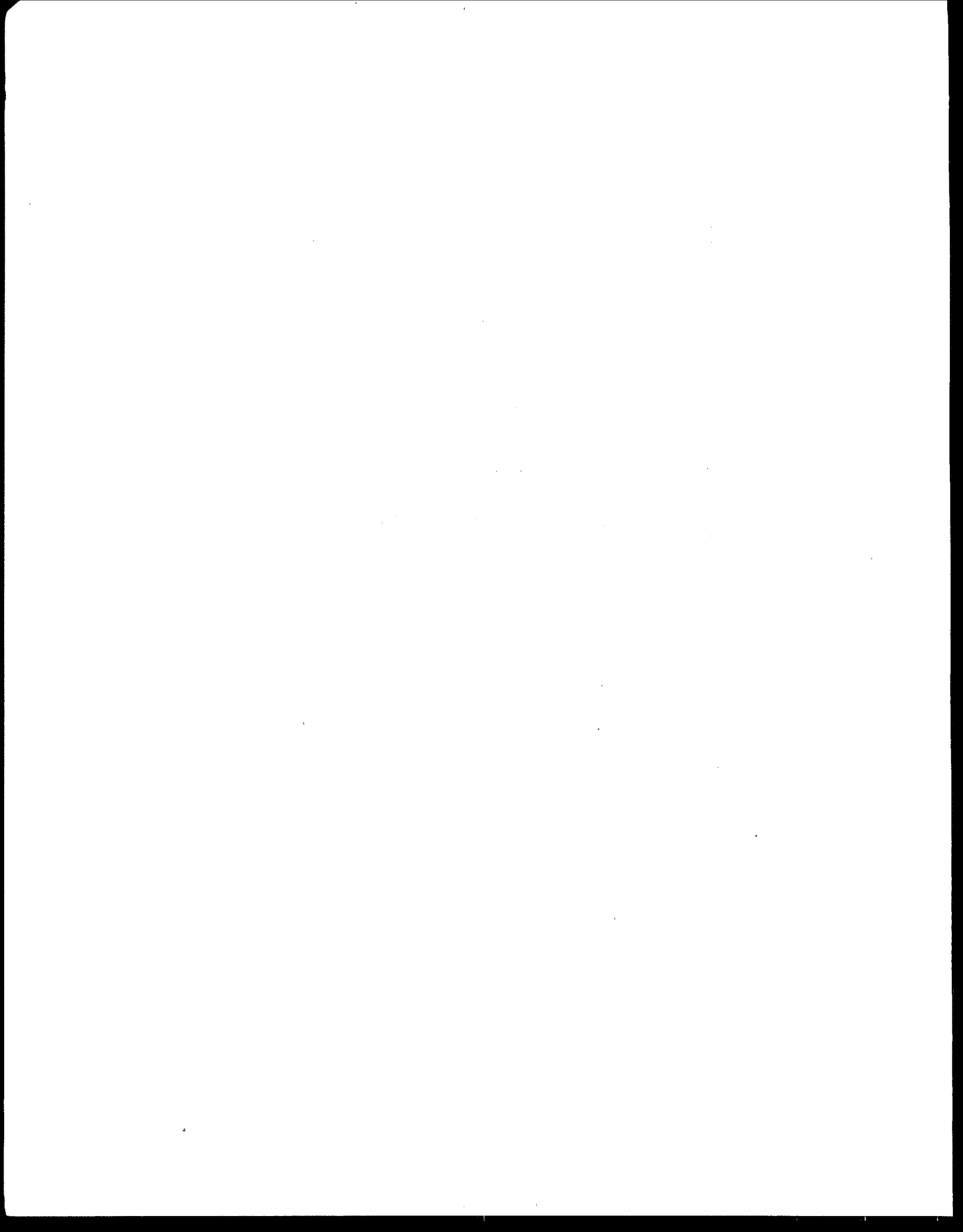

GENERAL DEVELOPMENT DOCUMENT

CONTENTS

<u>Section</u>	<u>Title</u>	<u>Page</u>
I	Summary and Conclusions	1
II	Recommendations	19
III	Introduction	21
IV	Industry Subcategorization	33
V	Water Use and Wastewater Characteristics	39
VI	Selection of Pollutant Parameters	49
VII	Control and Treatment Technology	141
VIII	Cost of Wastewater Treatment and Control	285
IX	Effluent Quality Attainable Through Application of the Best Practicable Control Technology Currently Available	365
X	Effluent Quality Attainable Through Application of the Best Available Technology Economically Achievable	391
XI	New Source Performance Standards	425
XII	Pretreatment Standards	441
XIII	Best Conventional Pollutant Control Technology	465
XIV	Acknowledgments	467
XV	References	469
XVI	Glossary	

GENERAL DEVELOPMENT DOCUMENT

LIST OF TABLES

<u>Table</u>	<u>Title</u>	<u>Page</u>
I-1	List of Subcategories Considered	7
I-2	Process Wastewater Streams Identified in Nonferrous Metals Manufacturing	8
I-3	Treatment Options Considered and Selected	16
II-1	Promulgated Effluent Limitations and Standards	20
III-1	Summary of DCP Respondents by Type of Metal Processed	32
V-1	Distribution of Sampled Plants in the Nonferrous Metals Manufacturing Category by Subcategories	48
VI-1	List of 129 Priority Pollutants	126
VI-2	Pollutants Selected for Further Consideration by Subcategory	131
VI-3	Polyneuclear Aromatic Hydrocarbons	143
VII-1	pH Control Effect on Metals Removal	235
VII-2	Effectiveness of Sodium Hydroxide for Metals Removal	235
VII-3	Effectiveness of Lime and Sodium Hydroxide for Metals Removal	236
VII-4	Theoretical Solubilities of Hydroxides and Sulfides of Selected Metals in Pure Water	236
VII-5	Sampling Data from Sulfide Precipitation -- Sedimentation Systems	237
VII-6	Sulfide Precipitation -- Sedimentation Performance	238
VII-7	Ferrite Co-Precipitation Performance	239
VII-8	Concentration of Total Cyanide	239
VII-9	Multimedia Filter Performance	240
VII-10	Performance of Selected Settling Systems	240
VII-11	Skimming Performance	241
VII-12	Selected Partition Coefficients	241

GENERAL DEVELOPMENT DOCUMENT

LIST OF TABLES (Continued)

<u>Table</u>	<u>Title</u>	<u>Page</u>
VII-13	Trace Organic Removal by Skimming -- API Plus Belt Skimmers	242
VII-14	Combined Metals Data Effluent Values	242
VII-15	L&S Performance -- Additional Pollutants	243
VII-16	Combined Metals Data Set-Untreated Wastewaters	243
VII-17	Pollutant Content of Untreated Wastewater	244
VII-18	Precipitation-Settling-Filtration (LS&F) Performance -- Plant A	245
VII-19	Precipitation-Settling-Filtration (LS&F) Performance -- Plant A	246
VII-20	Precipitation-Settling-Filtration (LS&F) Performance -- Plant A	247
VII-21	Summary of Treatment Effectiveness	248
VII-22	Treatability Rating of Priority Pollutants Utilizing Carbon Adsorption	249
VII-23	Classes of Organic Compounds Adsorbed on Carbon	250
VII-24	Activated Carbon Performance (MERCURY)	251
VII-25	Ion Exchange Performance	251
VII-26	Membrane Filtration System Effluent	252
VII-27	Peat Adsorption Performance	252
VII-28	Ultrafiltration Performance	253
VIII-1	BPT Cost of Compliance for the Nonferrous Metals Manufacturing Category	327
VIII-2	BAT Cost of Compliance for the Nonferrous Metals Manufacturing Category	328
VIII-3	PSES Costs of Compliance for the Nonferrous Metals Manufacturing Category	329
VIII-4	Nonferrous Metals Manufacturing Phase II Category Cost Equations for Recommended Treatment and Control Technologies	330

GENERAL DEVELOPMENT DOCUMENT

LIST OF TABLES (Continued)

<u>Table</u>	<u>Title</u>	<u>Page</u>
VIII-5	Components of Total Capital Investment	341
VIII-6	Components of Total Annualized Costs	342
VIII-7	Wastewater Sampling Frequency	343
VIII-8	Cost Program Pollutant Parameters	344
VIII-9	Flow Reduction Recycle Ratio and Associated Cost Assumptions	345
VIII-10	Nonferrous Metals Manufacturing (Phase I) Compliance Costs -- Secondary Silver Subcategory	347
VIII-11	Nonferrous Metals Manufacturing Waste Generation	348
VIII-12	Nonferrous Metals Manufacturing Energy Consumption	349
IX-1	Summary of Current Treatment Practices	383
IX-2	BPT Regulated Pollutant Parameters	386
X-1	Options Considered for Each of the Nonferrous Metals Manufacturing Subcategories	415
X-3	Priority Pollutants Effectively Controlled by Technologies Upon Which are Based Other Effluent Limitations and Guidelines	419
X-4	Toxic Pollutants Detected but only in Trace Amounts and are neither causing nor likely to cause Toxic Effects	424
XI-1	Regulated Pollutant Parameters	436
XII-1	Pollutants Selected for Regulation for Pretreatment Standards by Subcategory	461

GENERAL DEVELOPMENT DOCUMENT

LIST OF FIGURES

<u>Number</u>	<u>Title</u>	<u>Page</u>
VII-1	Comparative Solubilities of Metal Hydroxides and Sulfide as a Function of pH	254
VII-2	Effluent Zinc Concentration vs. Minimum Effluent pH	255
VII-3	Lead Solubility in Three Alkalis	256
VII-4	Hydroxide Precipitation Sedimentation Effectiveness -- Cadmium	257
VII-5	Hydroxide Precipitation Sedimentation Effectiveness -- Chromium	258
VII-6	Hydroxide Precipitation Sedimentation Effectiveness -- Copper	259
VII-7	Hydroxide Precipitation Sedimentation Effectiveness -- Lead	260
VII-8	Hydroxide Precipitation Sedimentation Effectiveness -- Nickel and Alumimum	261
VII-9	Hydroxide Precipitation Sedimentation Effectiveness -- Zinc	262
VII-10	Hydroxide Precipitation Sedimentation Effectiveness -- Iron	263
VII-11	Hydroxide Precipitation Sedimentation Effectiveness -- Manganese	264
VII-12	Hydroxide Precipitation Sedimentation Effectiveness -- TSS	265
VII-13	Hexaualent Chromium Reduction with Sulfur Dioxide	266
VII-14	Granular Bed Filtration	267
VII-15	Pressure Filtration	268
VII-16	Representative Types of Sedimentation	269
VII-17	Activated Carbon Adsorption Column	270
VII-18	Centrifugation	271
VII-19	Treatment of Cyanide Waste by Alkaline Chlorination	272

GENERAL DEVELOPMENT DOCUMENT

LIST OF FIGURES (Continued)

<u>Number</u>	<u>Title</u>	<u>Page</u>
VII-20	Typical Ozone Plant for Waste Treatment	273
VII-21	UV/Ozonation	274
VII-22	Types of Evaporation Equipment	275
VII-23	Dissolved Air Flotation	276
VII-24	Gravity Thickening	277
VII-25	Ion Exchange with Regeneration	278
VII-26	Simplified Reverse Osmosis Schematic	279
VII-27	Reverse Osmosis Membrane Configurations	280
VII-28	Sludge Drying Bed	281
VII-29	Simplified Ultrafiltration Flow Schematic	282
VII-30	Vacuum Filtration	283
VII-31	Flow Diagram for Recycling with a Cooling Tower	284
VIII-1	General Logic Diagram of Computer Cost Model	350
VIII-2	Logic Diagram of Module Design Procedure	351
VIII-3	Logic Diagram of the Cost Estimation Routing	352
VIII-4	Capital and Annual Costs for -- Cooling Tower, Holding Tank	353
VIII-5	Capital and Annual Costs for -- Flow Equalization	354
VIII-6	Capital and Annual Costs for -- Cyanide Precipitation	355
VIII-7	Capital and Annual Costs for -- Ammonia Steam Stripping	356
VIII-8	Capital and Annual Costs for -- Oil Water Separation	357
VIII-9	Capital and Annual Costs for -- Chemical Precipitation	358

GENERAL DEVELOPMENT DOCUMENT

LIST OF FIGURES (Continued)

<u>Number</u>	<u>Title</u>	<u>Page</u>
VIII-10	Capital and Annual Costs for -- Sulfide Precipitation	359
VIII-11	Capital and Annual Costs for -- Vacuum Filtration	360
VIII-12	Capital and Annual Costs for -- Holding Tanks, Recycle	361
VIII-13	Capital and Annual Costs for -- Multimedia Filtration	362
VIII-14	Capital and Annual Costs for -- Activated Carbon Adsorption	363
VIII-15	Costs for Contract Hauling	364

GENERAL DEVELOPMENT DOCUMENT

SECTION I

SUMMARY

The United States Environmental Protection Agency (EPA) has promulgated effluent limitations and standards for the nonferrous metals manufacturing category pursuant to Sections 301, 304, 306, 307, and 501 of the Clean Water Act. The promulgated regulation contains effluent limitations for best practicable control technology currently available (BPT), and best available technology economically achievable (BAT), as well as pretreatment standards for new and existing sources (PSNS and PSES), and new source performance standards (NSPS).

This development document presents the technical summary of EPA's study of the nonferrous metals manufacturing category. This volume summarizes the general findings of the study, while the remaining volumes contain supplements that detail specific results for each subcategory.

The Agency's economic analysis of the regulation is set forth in two documents entitled Economic Impact Analysis of Effluent Limitations, Guidelines and Standards for the Nonferrous Metals Manufacturing Point Source Category Phase I, and Phase II. These documents are available from the Office of Analysis and Evaluation, Economic Analysis Staff, WH-586, U.S. Environmental Protection Agency, Washington, D.C., 20460.

EXISTING REGULATIONS

Since 1974, implementation of the technology-based effluent limitations and standards has been guided by a series of settlement agreements into which EPA entered with several environmental groups, the latest of which occurred in 1979. NRDC v. Costle, 12 ERC 1833 (D.D.C. 1979), affirmed and remanded, EDF v. Costle, 14 ERC 2161 (1980). Under the settlement agreements, EPA was required to develop BAT limitations and pretreatment and new source performance standards for 65 classes of pollutants discharged from specific industrial point source categories. The list of 65 classes was substantially expanded to a list of 126 specific priority pollutants three of which subsequently have been removed.

METHODOLOGY

To develop the effluent limitations and standards presented in this document, the Agency characterized the category by subdividing it, collecting raw and treated wastewater samples, and examining water usage and discharge rates, and production processes. To gather data about the category, EPA developed a

questionnaire (data collection portfolio - dcp) to collect information regarding plant size, age and production, the production processes used, the quantity of process wastewater used and discharged, wastewater treatment in-place, and disposal practices. The dcp were sent to 540 firms (693 plants) known or believed to perform nonferrous smelting and refining operations. These responses were reviewed, and it was determined that there were 450 plants among the 693 plants queried that were within the nonferrous metals manufacturing point source category.

As a next step, EPA conducted a sampling and chemical analysis program to characterize the raw (untreated) and treated process wastewater. This program was carried out in three stages. In the first stage, 30 plants were sampled to characterize all the significant waste streams and production processes in these industries. In the second stage, 54 plants were sampled, to expand the data base, and to confirm data acquired during the first phase of sampling. The third stage consisted of a plant self-sampling effort in which eight plants submitted data on specific waste streams for which EPA had not previously acquired analytical data. These data were used to confirm assumptions made in developing the limitations. Samples were generally analyzed for 124 of the 126 priority pollutants and other pollutants deemed appropriate. Because no analytical standard was available for TCDD, samples were never analyzed for this pollutant, although there is no reason to believe that it would be present in nonferrous metals manufacturing wastewater. Also, few samples were analyzed for asbestos because there is no reason to believe that asbestos would be present in nonferrous metals manufacturing wastewaters. A discussion of the sampling and analytical methods and procedures is presented in Section V.

EPA then reviewed the rate of production and wastewater generation reported in the dcp's for each manufacturing operation, as well as the wastewater characteristics determined during sampling, as the principal basis for subcategorizing the industry. The data demonstrated that the industry should be subcategorized by major metal manufacturing process. A discussion of the subcategorization scheme is presented in Section IV. For this rulemaking, the nonferrous metals manufacturing point source category includes 36 subcategories (Table I-1, page 7). These subcategories addressed a total of 63 metals and metal types including both primary and secondary production.

The nonferrous metals manufacturing point source category is divided into subcategories based on differences in the quantity and quality of wastewater generated which are related to differences in manufacturing processes. This has resulted in the designation of 31 subcategories for regulation. Five subcategories were excluded from regulation. Primary boron, primary cesium and rubidium, primary lithium and secondary zinc were excluded because no plants in these subcategories discharge wastewater and primary magnesium was excluded because no plants in this subcategory discharge treatable concentrations of

pollutants. Each regulated subcategory is further subdivided into major sources of wastewater for specific limitation. The process wastewater streams identified in the nonferrous metals manufacturing category are listed by subcategory in Table I-2 (page 8).

There are more than 450 plants identified in the nonferrous metals manufacturing point source category discharging an estimated 136.2 billion liters per year of process wastewater. Untreated, this process wastewater contains approximately 3,650,000 kilograms of toxic pollutants.

The pollutants generated within the nonferrous metals manufacturing subcategories are diverse in nature due to varying raw materials and production processes. Thus, the Agency examined various end-of-pipe and pretreatment technologies to treat the pollutants present in the identified process wastewaters. The Pollutants selected for consideration for each subcategory are presented in Section VI. The treatment technologies considered for each subcategory are shown in Table I-3 (Page 16).

Engineering costs were prepared for each of the treatment options considered for each subcategory. These costs were then used by the Agency to estimate the impact of implementation of the various options by the industry. For each subcategory for each control and treatment option, the number of potential closures, number of employees affected, and impact on price were estimated. These results are reported in the economic impact analysis document.

The Agency then reviewed each of the treatment options for each subcategory to determine the estimated mass of pollutant removed by the application of each treatment technology. The pollutant removal after the application of the treatment technology is referred to as the benefit. The methodology used to calculate the pollutant removal estimates is presented in Section X.

TECHNOLOGY BASIS FOR LIMITATIONS AND STANDARDS

In general, the BPT level represents the average of the best existing performances of plants of various ages, sizes, processes or other common characteristics. Where existing performance is uniformly inadequate, BPT may be transferred from a different subcategory or category.

In balancing costs in relation to effluent reduction benefits, EPA considers the volume and nature of existing discharges, the volume and nature of discharges expected after application of BPT, the general environmental effects of the pollutants, and cost and economic impacts of the required pollution control level.

After examining the various treatment technologies, the Agency has identified BPT to represent the average of the best existing

plants. Metals removal based on chemical precipitation and sedimentation technology is the basis for the BPT limitations for 25 subcategories. Two subcategories, primary copper smelting and secondary copper, are already subject to zero discharge of all process wastewater pollutants. The Agency did not promulgate BPT requirements for three subcategories, secondary indium, secondary mercury, and secondary nickel because these subcategories contain no existing direct dischargers. EPA promulgated only minor technical amendments to the existing BPT limitations for the bauxite refining subcategory. Steam stripping is selected as the basis for ammonia limitations in nine subcategories. Air stripping is selected as the technology basis for ammonia limitations in one subcategory, namely, secondary molybdenum and vanadium. Oil skimming is selected as the basis for oil and grease limitations in three subcategories: primary precious metals and mercury, primary and secondary titanium, and secondary tungsten and cobalt. Cyanide precipitation is selected as the technology basis for cyanide limitations for the primary beryllium, secondary precious metals, secondary tin, and primary zirconium and hafnium subcategories. Ion exchange is selected as the technology basis for gold, platinum and palladium limitations in the primary precious metals and mercury, and secondary precious metals subcategories. Iron co-precipitation was selected as the technology basis for molybdenum limitations in the primary molybdenum and rhenium, metallurgical acid plants, and secondary molybdenum and vanadium subcategories. To meet the promulgated BPT effluent limitations based on these technologies, it is estimated that the nonferrous metals manufacturing point source category will incur a capital cost of \$7.28 million (1982 dollars) and an annual cost of \$9.3 million (1982 dollars).

The BAT technology level represents the best economically achievable performance of plants of various ages, sizes, processes or other shared characteristics. BAT may be transferred from a different subcategory or category. BAT may include feasible process changes or internal controls, even when not common industry practice.

In developing BAT, EPA has given substantial weight to the reasonableness of costs. The Agency considered the volume and nature of discharges, the volume and nature of discharges expected after application of BAT, the general environmental effects of the pollutants, and the costs and economic impacts of the required pollution control levels.

Despite this consideration of costs, the primary determinant of BAT is effluent reduction capability. For BAT, the Agency has built upon the BPT technology basis by adding in-process control technologies which include recycle of process water from air pollution control and metal contact cooling waste streams, as well as other flow reductions, where achievable. Filtration is added as an effluent polishing step to the end-of-pipe treatment scheme. Implementation of this technology increases the reliability of the treatment system by making it less susceptible to operator error and to surges in raw wastewater flow and

concentrations. Sulfide precipitation technology is added for primary copper electrolytic refining, primary lead, primary zinc, and metallurgical acid plants facilities.

To meet the BAT effluent limitations based on this technology, the nonferrous metals manufacturing point source category is estimated to incur a capital cost of \$28.4 million (1982 dollars) and an annual cost of \$22.7 million (1982 dollars).

New Source Performance Standards (NSPS) are based on the best demonstrated available technology (BDT), including process changes, in-plant controls, and end-of-pipe treatment technologies which reduce pollution to the maximum extent feasible. NSPS are equivalent to BAT for 25 subcategories. For three subcategories which currently have no direct dischargers, BAT was not promulgated. For one of these, secondary mercury, metals removal based on chemical precipitation, sedimentation, and filtration (the selected BAT for most of the 25 subcategories with direct dischargers) is the basis for NSPS limitations. For the secondary indium and secondary nickel subcategories chemical precipitation and sedimentation is selected as the basis for metals removal. In selecting NSPS, EPA recognizes that new plants have the opportunity to implement the best and most efficient manufacturing processes and treatment technology. As such, new source performance standards for the primary and secondary titanium subcategory are equivalent to BAT plus zero discharge for chip crushing, sponge crushing and screening, scrap milling, and chlorine liquefaction air pollution control. New source performance standards for the primary aluminum subcategory are based on dry alumina air pollution scrubbing systems or 100 percent recycle. Implementation of this technology at primary aluminum plants eliminates the discharge of toxic organics due to air emission scrubbing associated with anode paste plants, anode bake plants, potlines and potrooms. New source performance standards for the primary lead subcategory require zero discharge of all process wastewaters except for employee hand wash, employee respirator wash, and laundering of uniforms. Zero discharge for all other process wastewater is achievable through dry slag conditioning instead of using high pressure water jets to granulate smelter slag.

PSES (pretreatment standards for existing sources) are designed to prevent the discharge of pollutants which pass through, interfere with, or are otherwise incompatible with the operations of POTW. For PSES, the Agency selected the same technology as BAT, which is BPT end-of-pipe treatment in conjunction with in-process flow reduction control techniques followed by effluent polishing filtration, for the secondary aluminum, secondary copper, primary lead, primary zinc, metallurgical acid plants, primary tungsten, primary columbium-tantalum, secondary silver, secondary lead, secondary precious metals, primary rare earth metals, secondary tin, primary and secondary titanium, and secondary tungsten and cobalt subcategories. Chemical precipitation and sedimentation is selected as the technology basis for PSES limitations for the primary and secondary

germanium and gallium, secondary indium, and secondary nickel subcategories. The Agency did not promulgate PSES for the remaining 15 subcategories because there are no existing indirect dischargers in these subcategories. To meet the pretreatment standards for existing sources, the nonferrous metals manufacturing point source category is estimated to incur a capital cost of \$12.2 million (1982 dollars) and an annual cost of \$7.3 million (1982 dollars).

Pretreatment Standards for New Sources (PSNS) are designed to prevent the discharge of pollutants which pass through, interfere with, or are otherwise incompatible with the operation of the POTW. New indirect dischargers, like new direct dischargers, have the opportunity to incorporate the best available demonstrated technologies including process changes, in-plant controls, and end-of-pipe treatment technologies, and to use plant site selection to ensure adequate treatment system installation.

This regulation establishes mass-based PSNS for all 31 regulated subcategories. For PSNS, the Agency selected end-of-pipe treatment and in-process flow reduction control techniques equivalent to NSPS for 28 of the subcategories and equivalent to PSES for the remaining three subcategories.

Non-Water Quality Environmental Impacts

Eliminating or reducing one form of pollution may cause other environmental problems. Sections 304(b) and 306 of the Act require EPA to consider the non-water quality environmental impacts (including energy requirements) of certain regulations. In compliance with these provisions, EPA considered the effect of this regulation on air pollution, solid waste generation, water scarcity, and energy consumption.

This regulation was reviewed by EPA personnel responsible for non-water quality programs. While it is difficult to balance pollution problems against each other and against energy use, we believe that this regulation will best serve often competing national goals.

Wastewater treatment sludges from this category are expected to be non-hazardous by the E.P.Toxicity test under RCRA when generated using the model technology. Treatment of similar wastewaters from other categories using this technology has resulted in non-hazardous sludges. Costs for disposal of non-hazardous wastes are included in the annual costs. The only sludges expected to be hazardous under RCRA, generated as a result of wastewater treatment, are those from sulfide or cyanide precipitation steps. The Agency has included costs for disposal of those hazardous sludges in its estimates of compliance costs.

To achieve the BPT and BAT effluent limitations, a typical direct discharger will increase total energy consumption by less than one percent of the energy consumed for production purposes.

TABLE I-1

LIST OF SUBCATEGORIES CONSIDERED

1. Bauxite Refining
2. Primary Aluminum Smelting
3. Secondary Aluminum Smelting
4. Primary Copper Smelting
5. Primary Electrolytic Copper Refining
6. Secondary Copper
7. Primary Lead
8. Primary Zinc
9. Metallurgical Acid Plants
10. Primary Tungsten
11. Primary Columbium-Tantalum
12. Secondary Silver
13. Secondary Lead
14. Primary Antimony
15. Primary Beryllium
16. Primary Boron
17. Primary Cesium and Rubidium
18. Primary and Secondary Germanium and Gallium
19. Secondary Indium
20. Primary Lithium
21. Primary Magnesium
22. Secondary Mercury
23. Primary Molybdenum and Rhenium
24. Secondary Molybdenum and Vanadium
25. Primary Nickel and Cobalt
26. Secondary Nickel
27. Primary Precious Metals and Mercury
28. Secondary Precious Metals
29. Primary Rare Earth Metals
30. Secondary Tantalum
31. Secondary Tin
32. Primary and Secondary Titanium
33. Secondary Tungsten and Cobalt
34. Secondary Uranium
35. Secondary Zinc
36. Primary Zirconium and Hafnium

TABLE I-2

PROCESS WASTEWATER STREAMS IDENTIFIED IN
NONFERROUS METALS MANUFACTURINGBauxite Refining

Mud Impoundment Effluent (Net Precipitation Discharge)

Primary Aluminum Smelting

Anode and Cathode Paste Plant Wet Air Pollution Control
Anode Bake Plant Wet Air Pollution Control
Anode Contact Cooling and Briquette Quenching
Cathode Reprocessing
Potline Wet Air Pollution Control
Potroom Wet Air Pollution Control
Direct Chill Casting
Continuous Rod Casting
Stationary Casting or Shot Casting
Degassing Wet Air Pollution Control
Pot Repair and Soaking
Spent Potliner Leachate

Secondary Aluminum Smelting

Scrap Drying Wet Air Pollution Control
Scrap Screening and Milling
Dross Washing
Demagging Wet Air Pollution Control
Delacquering Wet Air Pollution Control
Direct Chill Casting
Ingot Conveyor Casting
Stationary Casting
Shot Casting

Primary Copper Smelting

Slag Granulation
Casting Contact Cooling
Casting Wet Air Pollution Control

Primary Electrolytic Copper Refining

Anode and Cathode Rinsing
Spent Electrolyte
Casting Contact Cooling
Casting Wet Air Pollution Control
By-Product Recovery

TABLE I-2 (Continued)

PROCESS WASTEWATER STREAMS IDENTIFIED IN
NONFERROUS METALS MANUFACTURING

Secondary Copper

Slag Milling and Classification
Smelting Wet Air Pollution Control
Casting Contact Cooling
Spent Electrolyte
Slag Granulation

Primary Lead

Sinter Plant Materials Handling Wet Air Pollution Control
Blast Furnace Slag Granulation
Blast Furnace Wet Air Pollution Control
Zinc Fuming Wet Air Pollution Control
Dross Reverberatory Slag Granulation
Dross Reverberatory Furnace Wet Air Pollution Control
Hard Lead Refining Slag Granulation
Hard Lead Refining Wet Air Pollution Control
Facility Washdown
Employee Hand Wash
Employee Respirator Wash
Laundering of Uniforms

Primary Zinc

Zinc Reduction Furnace Wet Air Pollution Control
Preleach of Zinc Concentrates
Leaching Wet Air Pollution Control
Electrolyte Bleed Wastewater
Cathode and Anode Washing
Casting Wet Air Pollution Control
Casting Contact Cooling
Cadmium Plant Wastewater

Metallurgical Acid Plants

Acid Plant Blowdown

TABLE I-2 (Continued)

PROCESS WASTEWATER STREAMS IDENTIFIED IN
NONFERROUS METALS MANUFACTURINGPrimary Tungsten

Tungstic Acid Rinse
 Acid Leach Wet Air Pollution Control
 Alkali Leach Wash
 Ion-Exchange Raffinate
 Calcium Tungstate Precipitate Wash
 Crystallization and Drying of Ammonium Paratungstate
 Ammonium Paratungstate Conversion to Oxide Wet Air
 Pollution Control
 Ammonium Paratungstate Conversion to Oxides Water of
 Formation
 Reduction to Tungsten Wet Air Pollution Control
 Reduction to Tungsten Water of Formation
 Tungsten Powder Acid Leach and Wash
 Molybdenum Sulfide Precipitation Wet Air Pollution Control
 Alkali Leach Condensate

Primary Columbium-Tantalum

Concentrate Digestion Wet Air Pollution Control
 Solvent Extraction Raffinate
 Solvent Extraction Wet Air Pollution Control
 Precipitation and Filtration of Metal Salts
 Precipitation and Filtration Wet Air Pollution Control
 Tantalum Salt Drying
 Reduction of Tantalum Salt to Metal
 Reduction of Tantalum Salt to Metal Wet Air Pollution
 Control
 Oxides Calcining Wet Air Pollution Control
 Tantalum Powder Wash
 Consolidation and Casting Contact Cooling

Secondary Silver

Film Stripping
 Film Stripping Wet Air Pollution Control
 Precipitation and Filtration of Film Stripping Solutions Wet
 Air Pollution Control
 Precipitation and Filtration of Film Stripping Solutions
 Precipitation and Filtration of Photographic Solutions
 Precipitation and Filtration of Photographic Solutions Wet
 Air Pollution Control
 Electrolytic Refining
 Furnace Wet Air Pollution Control
 Leaching
 Leaching Wet Air Pollution Control
 Precipitation of Nonphotographic Solutions Wet Air Pollution
 Control
 Precipitation and Filtration of Nonphotographic Solutions
 Floor and Equipment Washdown

TABLE I-2 (Continued)

PROCESS WASTEWATER STREAMS IDENTIFIED IN
NONFERROUS METALS MANUFACTURINGSecondary Lead

Battery Cracking
Blast, Reverberatory, and Rotary Furnace Wet Air Pollution
Control
Kettle Wet Air Pollution Control
Casting Contact Cooling
Lead Paste Desulfurization
Truck Wash
Facility Washdown
Battery Case Classification
Employee Hand Wash
Employee Respirator Wash
Laundering of Uniforms

Primary Antimony

Sodium Antimonate Autoclave Wastewater
Fouled Anolyte
Cathode Antimony Washwater

Primary Beryllium

Solvent Extraction Raffinate from Bertrandite Ore
Solvent Extraction Raffinate from Beryl Ore
Beryllium Carbonate Filtrate
Beryllium Hydroxide Filtrate
Beryllium Oxide Calcining Furnace Wet Air Pollution Control
Beryllium Hydroxide Supernatant
Process Water
Fluoride Furnace Scrubber
Chip Treatment Wastewater
Beryllium Pebble Plant Area-Vent Wet Air Pollution Control
Beryl Ore Gangue Dewatering
Bertrandite Ore Gangue Dewatering
Beryl Ore Processing
AIS Area Wastewater
Bertrandite Ore Leaching Scrubber
Bertrandite Ore Counter Current
Decantation Scrubber

Primary and Secondary Germanium and Gallium

Still Liquor
Chlorinator Wet Air Pollution Control
Germanium Hydrolysis Filtrate
Acid Wash and Rinse Water
Gallium Hydrolysis Filtrate
Solvent Extraction Raffinate

TABLE I-2 (Continued)

PROCESS WASTEWATER STREAMS IDENTIFIED IN
NONFERROUS METALS MANUFACTURINGSecondary Indium

Displacement Tank Supernatant
Spent Electrolyte

Secondary Mercury

Spent Battery Electrolyte
Acid Wash and Rinse Water
Furnace Wet Air Pollution Control

Primary Molybdenum and Rhenium

Molybdenum Sulfide Leaching
Roaster SO₂ Scrubber
Molybdic Oxide Leachate
Hydrogen Reduction Furnace Scrubber
Depleted Rhenium Scrubbing Solution

Secondary Molybdenum and Vanadium

Leach Tailings
Molybdenum Filtrate Solvent Extraction Raffinate
Vanadium Decomposition Wet Air Pollution Control
Molybdenum Drying Wet Air Pollution Control
Pure Grade Molybdenum

Primary Nickel and Cobalt

Raw Material Dust Control
Nickel Wash Water
Nickel Reduction Decant
Cobalt Reduction Decant

Secondary Nickel

Slag Reclaim Tailings
Acid Reclaim Leaching Filtrate
Acid Reclaim Leaching Belt Filter Backwash

TABLE I-2 (Continued)

PROCESS WASTEWATER STREAMS IDENTIFIED IN
NONFERROUS METALS MANUFACTURINGPrimary Precious Metals and Mercury

Smelter Wet Air Pollution Control
Silver Chloride Reduction Spent Solution
Electrolytic Cells Wet Air Pollution Control
Electrolyte Preparation Wet Air Pollution Control
Calciner Wet Air Pollution Control
Calciner Quench Water
Calciner Stack Gas Contact Cooling Water
Mercury Calcining Condensate
Mercury Cleaning Bath Water

Secondary Precious Metals

Furnace Wet Air Pollution Control
Raw Material Granulation
Spent Plating Solutions
Spent Cyanide Stripping Solutions
Retinery Wet Air Pollution Control
Gold Solvent Extraction Raffinate and Wash Water
Gold Spent Electrolyte
Gold Precipitation and Filtration
Platinum Precipitation and Filtration Palladium Precipitation and
Filtration Other Platinum Group Metals Precipitation and
Filtration Spent Solution from PGC Salt Production Equipment and
Floor Wash
Preliminary Treatment

Primary Rare Earth Metals

Dryer Vent Water Quench and Scrubber
Dryer Vent Caustic Wet Air Pollution Control
Electrolytic Cell Water Quench and Scrubber
Electrolytic Cell Caustic Wet Air Pollution Control
Sodium Hypochlorite Filter Backwash

Secondary Tantalum

Tantalum Alloy Leach and Rinse
Capacitor Leach and Rinse
Tantalum Sludge Leach and Rinse
Tantalum Powder Acid Wash and Rinse
Leaching Wet Air Pollution Control

TABLE I-2 (Continued)

PROCESS WASTEWATER STREAMS IDENTIFIED IN
NONFERROUS METALS MANUFACTURINGSecondary Tin

Tin Smelter SO₂ Scrubber
Dealuminizing Rinse
Tin Hydroxide Wash
Tin Mud Acid Neutralization Filtrate
Spent Electrowinning Solution from New Scrap
Spent Electrowinning Solution from Municipal Solid Waste
Tin Hydroxide Supernatant from Scrap
Tin Hydroxide Supernatant from Spent Flating Solutions and
Sludges
Tin Hydroxide Filtrate

Primary and Secondary Titanium

Chlorination Off-Gas Wet Air Pollution Control
Chlorination Area-Vent Wet Air Pollution Control
TiCl₄ Handling Wet Air Pollution Control
Reduction Area Wet Air Pollution Control
Melt Cell Wet Air Pollution Control
Chlorine Liquefaction Wet Air Pollution Control
Sodium Reduction Container Reconditioning Wash Water
Chip Crushing Wet Air Pollution Control
Acid Leachate and Rinse Water
Sponge Crushing and Screening Wet Air Pollution Control
Acid Pickle and Wash Water
Scrap Milling Wet Air Pollution Control
Scrap Detergent Wash Water
Casting Crucible Wash Water
Casting Contact Cooling Water

Secondary Tungsten and Cobalt

Tungsten Detergent Wash and Rinse
Tungsten Leaching Acid
Tungsten Post-Leaching Wash and Rinse
Synthetic Scheelite Filtrate
Tungsten Carbide Leaching Wet Air Pollution Control
Tungsten Carbide Wash Water
Cobalt Sludge Leaching Wet Air Pollution Control
Crystallization Decant
Acid Wash Decant
Cobalt Hydroxide Filtrate
Cobalt Hydroxide Filter Cake Wash

TABLE I-2 (Continued)

PROCESS WASTEWATER STREAMS IDENTIFIED IN
NONFERROUS METALS MANUFACTURINGSecondary Uranium

Refinery Sump Filtrate
Slag leach Reslurry
Solvent Extraction Raffinate Filtrate
Digestion Wet Air Pollution Control
Evaporation and Denitration Wet Air Pollution Control
Hydrofluorination Alkaline Scrubber
Hydrofluorination Water Scrubber
Magnesium Reduction and Casting Floor Wash Water
Laundry Wastewater

Primary Zirconium and Hafnium

Sand Drying Wet Air Pollution Control
Sand Chlorination Off-Gas Wet Air Pollution Control
Sand Chlorination Area-Vent Wet Air Pollution Control
SiCl₄ Purification Wet Air Pollution Control
Feed Make-up Wet Air Pollution Control
Iron Extraction (MIBK) Steam Stripper Bottoms
Zirconium Filtrate
Hafnium Filtrate
Calcining Caustic Wet Air Pollution Control
Pure Chlorination Wet Air Pollution Control
Reduction Area-Vent Wet Air Pollution Control
Magnesium Recovery Off Gas Wet Air Pollution Control
Magnesium Recovery Area-Vent Wet Air Pollution Control
Zirconium Chip Crushing Wet Air Pollution Control
Acid Leachate from Zirconium Metal Production
Acid Leachate from Zirconium Alloy Production
Leaching Rinse Water from Zirconium Metal Production
Leaching Rinse Water from Zirconium Alloy Production

TABLE I-3

TREATMENT OPTIONS CONSIDERED AND SELECTED

Subcategory	Treatment Technology Options						
	Considered			Selected			
	A	B	C	E	BPT	BAT	NSPS
Bauxite Refining				X	ZD	ZD	ZD
Primary Aluminum Smelting	X	X	X		-	C	C
Secondary Aluminum Smelting	X	X	X		-	C	C
Primary Copper Smelting	X		X		-	ZD	ZD
Primary Copper Electrolytic Refining	X	X	X		-	C	C
Secondary Copper	X		X		-	ZD	ZD
Primary Lead	X	X	X		A	C	C
Primary Zinc	X	X	X		-	C	C
Metallurgical Acid Plants	X	X	X		A	C	C
Primary Tungsten	X	X	X	X	A	C	C
Primary Columbium-Tantalum	X	X	X	X	A	C	C
Secondary Silver	X	X	X	X	A	C	C
Secondary Lead	X	X	X		A	C	C
Primary Antimony	X		X		A	C	C
Primary Beryllium	X		X		A	C	C
Primary Boron	X		X		-	-	-
Primary Cesium and Rubidium	X		X		-	-	-
Primary and Secondary Germanium and Gallium	X		X		A	A	A
Secondary Indium	X		X		-	-	A
Secondary Mercury	X		X		-	-	C
Primary Molybdenum and Rhenium	X	X	X		A	C	C
Secondary Molybdenum and Vanadium	X		X		A	C	C
Primary Nickel and Cobalt	X		X		A	C	C
Secondary Nickel	X		X		-	-	A
Primary Precious Metals and Mercury	X	X	X		A	C	C
Secondary Precious Metals	X	X	X		A	C	C
Primary Rare Earth Metals	X	X	X	X	-	-	C

TABLE I-3 (Continued)

TREATMENT OPTIONS CONSIDERED AND SELECTED

Subcategory	Treatment Technology Options Considered				Selected		
	A	B	C	E	BPT	BAT	NSPS
Secondary Tantalum	X		X		A	C	C
Secondary Tin	X		X		A	C	C
Primary and Secondary Titanium	X	X	X		A	C	C
Secondary Tungsten and Cobalt	X	X	X		A	C	C
Secondary Uranium	X		X		A	C	C
Primary Zirconium and Hafnium	X		X		A	C	C

Notes: Option A - Chemical precipitation and sedimentation and sulfide precipitation, iron co-precipitation, ion exchange, cyanide precipitation, ammonia steam or air stripping, activated carbon adsorption or oil skimming where appropriate.

Option B - Option A preceded by flow reduction by recycling variable quantities of process wastewater.

Option C - Option B plus filtration.

Option E - Option C plus activated carbon adsorption.

ZD - No discharge allowance for pollutants in process wastewater discharged.

THIS PAGE INTENTIONALLY LEFT BLANK

SECTION II

CONCLUSIONS

The nonferrous metals manufacturing point source category has been divided into thirty six subcategories, thirty one of which are regulated by this regulation. The Agency concluded that five of the subcategories should not be regulated at this time and that the remaining thirty one should be subject to effluent limitations and standards published in the Federal Register. For some of the subcategories, limitations or standards were not developed for existing sources because there were either no direct discharging or no indirect discharging sources. Table II-1 (Page 20) lists all of the regulated subcategories and the limitations and standards promulgated within each subcategory. BCT limitations are not promulgated for any subcategory.

Section II of the development document supplement for each specific subcategory contains a tabulation of the specific numerical limitations and standards for that subcategory.

TABLE II-1

PROMULGATED EFFLUENT LIMITATIONS AND STANDARDS

Subcategory	BPT	BAT	NSPS	PSES	PSNS
Bauxite Refining	X	X	X		
Primary Aluminum Smelting	X	X	X	X	X
Secondary Aluminum Smelting	X	X	X	X	X
Primary Copper Smelting	X	X	X	X	X
Primary Electrolytic Copper Refining	X	X	X		X
Secondary Copper	X	X	X	X	X
Primary Lead	X	X	X	X	X
Primary Zinc	X	X	X	X	X
Primary Tungsten	X	X	X	X	X
Primary Columbium & Tantalum	X	X	X	X	X
Secondary Silver	X	X	X	X	X
Secondary Lead	X	X	X	X	X
Primary Antimony	X	X	X	X	X
Primary Beryllium	X	X	X		X
Primary and Secondary Germanium and Gallium	X	X	X		X
Secondary Indium			X	X	X
Secondary Mercury			X		X
Primary Molybdenum and Rhenium	X	X	X		X
Metallurgical Acid Plants	X	X	X	X	X
Secondary Molybdenum and Vanadium	X	X	X		X
Primary Nickel and Cobalt	X	X	X		X
Secondary Nickel			X	X	X
Primary Precious Metals Mercury	X	X	X		X
Secondary Precious Metals	X	X	X	X	X
Primary Rare Earth Metals			X	X	X
Secondary Tantalum	X	X	X		X
Secondary Tin	X	X	X	X	X
Primary and Secondary Titanium	X	X	X	X	X
Secondary Tungsten and Cobalt	X	X	X	X	X
Secondary Uranium	X	X	X		X
Primary Zirconium and Hafnium	X	X	X		X

SECTION III

INTRODUCTION

PURPOSE AND AUTHORITY

The Federal Water Pollution Control Act Amendments of 1972 established a comprehensive program to "restore and maintain the chemical, physical, and biological integrity of the Nation's waters," Section 101(a). By July 1, 1977, existing industrial dischargers were required to achieve "effluent limitations requiring the application of the best practicable control technology currently available" (BPT), Section 301(b)(1)(A). By July 1, 1984, these dischargers were required to achieve "effluent limitations requiring the application of the best available technology economically achievable -- which will result in reasonable further progress toward the national goal of eliminating the discharge of all pollutants" (BAT), Section 301(b)(2)(A). New industrial direct dischargers were required to comply with Section 306 new source performance standards (NSPS), based on best available demonstrated technology; and new and existing dischargers to publicly owned treatment works (POTW) were subject to pretreatment standards under Sections 307(b) and (c) of the Act. The requirements for direct dischargers were to be incorporated into National Pollutant Discharge Elimination System (NPDES) permits issued under Section 402 of the Act. Pretreatment standards were made enforceable directly against dischargers to POTW (indirect dischargers).

Although Section 402(a)(1) of the 1972 Act authorized the setting of requirements for direct dischargers on a case-by-case basis, Congress intended that, for the most part, control requirements would be based on regulations promulgated by the Administrator of EPA. Section 304(b) of the Act required the Administrator to promulgate regulations providing guidelines for effluent limitations setting forth the degree of effluent reduction attainable through the application of BPT and BAT. Moreover, Sections 304(c) and 306 of the Act required promulgation of regulations for NSPS, and Sections 304(f), 307(b), and 307(c) required promulgation of regulations for pretreatment standards. In addition to these regulations for designated industry categories, Section 307(a) of the Act required the Administrator to promulgate effluent standards applicable to all dischargers of toxic pollutants. Finally, Section 501(a) of the Act authorized the Administrator to prescribe any additional regulations "necessary to carry out his functions" under the Act.

EPA was unable to promulgate many of these regulations by the dates contained in the Act. In 1976, EPA was sued by several environmental groups, and in settlement of this lawsuit, EPA and the plaintiffs executed a "Settlement Agreement" which was approved by the District Court. This Agreement required EPA to develop a program and adhere to a schedule for promulgating, for

21 major industries, BAT effluent limitations guidelines, pretreatment standards, and new source performance standards for 65 "priority" pollutants and classes of pollutants. See Natural Resources Defense Council, Inc. v. Train, 8 ERC 2120 (D.D.C. 1976), modified, 12 ERC 1833 (D.D.C. 1979), modified by additional orders of August 25, 1982, October 26, 1982, August 2, 1983 and January 6, 1984.

On December 27, 1977, the President signed into law the Federal Water Pollution Control Act (P.L. 95-217), commonly referred to as the Clean Water Act of 1977. Although this law makes several important changes in the federal water pollution control program, its most significant feature is it incorporates into the Act several of the basic elements of the Settlement Agreement program for toxic pollutant control. Sections 301(b)(2)(A) and 301(b)(2)(C) of the Act now require the achievement of effluent limitations requiring BAT for "toxic" pollutants, including the 65 "pollutants and classes of pollutants which Congress declared "toxic" under Section 307(a) of the Act. Likewise, EPA's programs for new source performance standards and pretreatment standards are now aimed principally at toxic pollutant controls. Moreover, to strengthen the toxics control program, Section 304(e) of the Act authorizes the Administrator to prescribe "best management practices" (BMP) to prevent the release of toxic and hazardous pollutants from plant site runoff, spillage or leaks, sludge or waste disposal, and drainage from raw material storage associated with, or ancillary to, the manufacturing or treatment process.

The 1977 Amendments added Section 301(b)(2)(E) to the Act, establishing "best conventional pollutant control technology" (BCT) for discharges of conventional pollutants from existing industrial point sources. Conventional pollutants are those mentioned specifically in Section 304(a)(4) (biochemical oxygen demanding pollutants (BOD) total suspended solids (TSS) fecal coliform, and pH), and any additional pollutants defined by the Administrator as "conventional." (To date, the Agency has added one such pollutant, oil and grease, 44 FR 44501, July 30, 1979.) before establishing them as BCT. In no case may BCT be less stringent than BPT.

BCT is not an additional limitation but replaces BAT for the control of conventional pollutants. In addition to other factors specified in Section 304(b)(4)(B), the Act requires that BCT limitations be assessed in light of a two-part "cost-reasonableness" test, American Paper Institute v. EPA, 660 F.2d 954 (4th Cir. 1981). The first test compares the cost for private industry to reduce its conventional pollutants with the costs to publicly owned treatment works for similar levels of reduction in their discharge of these pollutants. The second test examines the cost-effectiveness of additional industrial treatment beyond BPT. EPA must find that limitations are "reasonable" under both tests.

EPA published its methodology for carrying out the BCT analysis on August 29, 1979 (44 FR 50372). In the case mentioned above, the Court of Appeals ordered EPA to correct data errors underlying EPA's calculation of the first test, and to apply the second cost test. (EPA had argued that a second cost test was not required.)

A revised methodology for the general development of BCT limitations was proposed on October 29, 1982 (47 FR 49176), but had not been promulgated as a final rule when this regulation was promulgated. We accordingly have not proposed BCT limits for plants in the nonferrous metals manufacturing category. We will await establishing nationally applicable BCT limits for this industry until promulgation of the final methodology for BCT.

For nonconventional pollutants, Sections 301(b)(2)(A) and (b)(2)(F) require achievement of BAT effluent limitations within three years after their establishment or July 1, 1984, whichever is later, but not later than July 1, 1987.

The purpose of these promulgated regulations is to provide effluent limitations guidelines for BPT and BAT, and to establish NSPS, pretreatment standards for existing sources (PSES), and pretreatment standards for new sources (PSNS), under Sections 301, 304, 306, 307, and 501 of the Clean Water Act.

PRIOR EPA REGULATIONS

EPA previously promulgated effluent limitations and pretreatment standards for certain nonferrous metals manufacturing subcategories. The nonferrous metals manufacturing regulations existing prior to the present rulemaking effort (Phase I and Phase II) and the technological basis for them are briefly discussed below.

Bauxite Refining Subcategory. EPA promulgated BPT, BAT, NSPS, and PSNS in this subcategory (39 FR 12822, March 26, 1974). BPT, BAT, NSPS and PSNS were based on zero discharge of process wastewater, but allow for a monthly net precipitation discharge from the red mud impoundment.

Primary Aluminum Subcategory. EPA promulgated BPT, BAT, NSPS, and PSNS in this subcategory (39 FR 12822, March 26, 1974). BPT was based on lime precipitation and sedimentation technology. BAT was based on this technology and flow reduction; NSPS and PSNS were based on BPT plus additional flow reduction.

Secondary Aluminum Subcategory. Existing regulations in this subcategory cover BPT, BAT, NSPS, PSES and PSNS (39 FR 12822 (March 26, 1974) and 41 FR 54854 (December 15, 1976) (establishing pretreatment standards)). BPT was based on lime precipitation and sedimentation with pH adjustment to control ammonia. BAT required no discharge of wastewater pollutants, PSES was based on oil skimming, pH adjustment and ammonia air stripping, while NSPS and PSNS were based on lime precipitation

and sedimentation and flow reduction. (Promulgated NSPS and PSNS were less stringent than BAT and PSES because the processes believed to be necessary to achieve zero discharge were not yet demonstrated in 1974 or 1976, but it was believed that they would be demonstrated at the time of the BAT and PSES compliance dates.)

Primary Copper Smelting. The existing regulation covered BPT and BAT. The amended BPT required no discharge of process wastewater pollutants subject to an exception for unlimited discharge of the volume of water falling within impoundments in excess of the 10-year, 24-hour storm (known as a catastrophic precipitation event) when a storm of at least that magnitude occurred. See 45 FR 44926 (July 2, 1980). Existing BAT, promulgated earlier (40 FR 8523 (February 27, 1975)), was less stringent than BPT, allowing as exemptions to zero discharge a similar unlimited discharge for stormwater (except the allowance is for a volume of wastewater in excess of a 25-year, 10-hour storm), and a further discharge during any calendar month equal in volume to the difference between precipitation on and evaporation from the impoundment during that month. This latter discharge is subject to concentration-based limitations.

Primary Electrolytic Copper Refining. Existing regulations cover BPT and BAT. The BPT regulation for this subcategory allowed a mass-based continuous discharge based on lime precipitation and sedimentation. 45 FR 44926 (July 2, 1980). The BAT regulation, promulgated earlier (40 FR 8524 (February 27, 1975)) was impoundment rather than hardware-based, and established a mass-based continuous discharge limitation, based on flow reduction, lime precipitation, sedimentation, and the same allowances for catastrophic stormwater discharge and net precipitation discharge described for primary copper smelting, previously. (Refiners located in areas of net evaporation, however, cannot discharge process wastewaters, based on the use of solar evaporation. The monthly net precipitation and catastrophic discharges may be discharged.)

Secondary Copper. EPA established BPT, BAT and PSES in this subcategory. BPT and BAT, based on the presence of impoundments (or cooling tower circuits), required no discharge of process wastewater pollutants with allowances for catastrophic stormwater discharge and net precipitation discharge as described above when impoundments are used instead of cooling tower circuits. See 40 FR 8526 (February 27, 1975). PSES, promulgated later (41 FR 54854 (December 15, 1976)) was based on lime precipitation and sedimentation.

Primary Lead. The existing BPT and BAT limitations in this subcategory were based on impoundments. See 40 FR (February 27, 1975). These limitations required no discharge of process wastewater pollutants, with exemptions for catastrophic stormwater and net precipitation discharge of acid plant blowdown (subject to mass limitations) and monthly net precipitation on impoundments. The existing limitations did not apply to primary

lead refineries not on-site with a smelter.

Primary Zinc. EPA promulgated BPT and BAT in this subcategory. See 40 FR 8528 (February 27, 1975). This limitation was based on lime precipitation and sedimentation technology for BPT, with flow reduction added for BAT.

Metallurgical Acid Plants. This subcategory was established in 1980, and at that time included only acid plants (i.e., plants recovering by-product sulfuric acid from sulfur dioxide smelter air emissions) associated with primary copper smelting operations. (See 45 FR 44926.) Primary lead and zinc plants also have associated acid plants; the applicability of the metallurgical acid plants subcategory was expanded to include these sources and was finalized on March 8, 1984 (49 FR 8742). EPA further expanded the existing regulation for metallurgical acid plants by modifying the applicability of the metallurgical acid plants subcategory to include molybdenum acid plants.

METHODOLOGY

Approach of Study

The nonferrous metals manufacturing category comprises plants that process ore concentrates and scrap metals to recover and increase the metal purity contained in these materials. The promulgated effluent limitations and standards for nonferrous metals manufacturing addresses 31 subcategories (See Table I-3, page 15).

The 31 subcategories in nonferrous metals manufacturing contain 38 primary metals and metal groups, 24 secondary metals and metal groups, and bauxite refining. A group of metals-- including six primary metals and five secondary metals--were excluded from regulation either because the manufacturing processes do not use water or because they are regulated by toxics limitations and standards in other categories (e.g., ferroalloys and inorganic chemicals). Four of these metals which were excluded from regulation on May 10, 1979 -- primary antimony, primary tin, secondary molybdenum, and secondary tantalum -- have since been reconsidered based on information received during more recent data collection efforts. EPA also studied the segments of the nonferrous metals industry associated with forming or casting nonferrous metals. EPA promulgated regulations for aluminum forming (48 FR 49126) in October, 1983; for copper forming (48 FR 36942) in August, 1983; for metal molding and casting (50 FR 45212) October, 1985; and for forming of nonferrous metals other than aluminum and copper (50 FR 34242) in August, 1985.

In the course of developing these guidelines, EPA gathered and evaluated technical data in order to perform the following tasks:

1. To profile the category with regard to the production, manufacturing processes, geographical distribution, potential wastewater streams, and discharge mode of nonferrous metals

manufacturing plants.

2. To subcategorize, if necessary, in order to permit regulation of the nonferrous metals manufacturing category in an equitable and manageable way.

3. To characterize wastewater, detailing water use, wastewater discharge, and the occurrence of toxic, conventional, and nonconventional pollutants, in waste streams from nonferrous metals manufacturing processes.

4. To select pollutant parameters -- those toxic, nonconventional, or conventional pollutants present at significant concentrations in wastewater streams -- that should be considered for regulation.

5. To consider control and treatment technologies and select alternative methods for reducing pollutant discharge in this category.

6. To evaluate the costs of implementing the alternative control and treatment technologies.

7. To present regulatory alternatives.

Data Collection and Methods of Evaluation

Data on the nonferrous metals manufacturing category were gathered from previous EPA studies, literature studies, inquiries to federal and state environmental agencies, trade association contacts and the manufacturers themselves. Meetings were also held with industry representatives and the EPA. All known companies within the nonferrous metals manufacturing category were sent data collection portfolios to solicit specific information concerning each facility. Finally, a sampling program was carried out at 84 plants. Wastewater samples were collected in three phases. In the first phase, 30 plants were sampled in an attempt to characterize all the significant waste streams and production processes in these segments. In the second phase, 46 plants were sampled to expand the data base, and to confirm data acquired during the first phase of sampling. The third stage consisted of a plant self-sampling effort, in which eight plants submitted data on specific waste streams for which EPA had not previously acquired analytical data. These data were used to confirm assumptions made in developing the limitations. Samples were generally analyzed for 124 of the 126 toxic pollutants and other pollutants deemed appropriate. Because no analytical standard was available for TCDD, samples were never analyzed for this pollutant, although there is no reason that it would be present in nonferrous metals manufacturing wastewater. Asbestos was not analyzed for in any of the samples because there was no reason to believe it would be present in wastewater resulting from the manufacture of nonferrous metals. At least one plant in every major subcategory was sampled during the data collection effort, with some subcategories sampled at more than one plant, when the

production processes were different.

Specific details of the sampling program and information from the above data sources are presented in Section V. Details on selection of plants for sampling, and analytical results, are contained in Section V of each of the subcategory supplements.

Literature Review. EPA reviewed and evaluated existing literature for background information to clarify and define various aspects of the nonferrous metals manufacturing category and to determine general characteristics and trends in production processes and wastewater treatment technology. Review of current literature continued throughout the development of these limitations and standards. Information gathered in this review was used, along with information from other sources as discussed below, in the following specific areas:

Subcategory Profile (Section III of each of the subcategory supplements) - Description of production processes and the associated raw materials and wastewater streams.

Subcategorization (Section IV of each of the subcategory supplements) - Identification of differences in manufacturing process technology and their potential effect on associated wastewater streams.

Selection of Pollutant Parameters (Section VI) - Information regarding the toxicity and potential sources of the pollutants identified in wastewater from nonferrous metals manufacturing processes.

Control and Treatment Technology (Section VII) - Information on alternative controls and treatment and corresponding effects on pollutant removal.

Costs (Section VIII) - Formulation of the methodology for determining the current capital and annual costs to apply the selected treatment alternatives.

Existing Data. Previous EPA studies of the following nonferrous metals manufacturing subcategories were reviewed:

Primary Aluminum
 Secondary Aluminum
 Primary Copper
 Secondary Copper
 Primary Lead
 Primary Zinc
 Secondary Lead
 Primary Columbium-Tantalum
 Primary Beryllium
 Primary and Secondary Germanium
 Primary Magnesium
 Secondary Zinc
 Primary Zirconium and Hafnium

The available information included a summary of the category describing the production processes, the wastewater characteristics associated with the processes, recommended pollutant parameters requiring control; applicable end-of-pipe treatment technologies for wastewaters; effluent characteristics resulting from this treatment, and a background bibliography. Also included in these studies were detailed production and sampling information for many plants.

The concentration or mass loading of pollutant parameters in wastewater effluent discharges are monitored and reported as required by individual state agencies. Where available, these historical data were obtained from NPDES monitoring reports and reviewed.

Other useful data sources were industry personnel and trade associations. Contributions from these sources were particularly useful for clarifying differences in production processes. Finally, general information was derived from publications of the U.S. Bureau of Mines, including the Minerals Yearbook and supplements, and through discussions with commodity experts at the U.S. Bureau of Mines.

Data Collection Portfolios. EPA conducted a survey of the non-ferrous metals manufacturing plants to gather information regarding plant size, age and production, the production processes used, economic parameters, and the quantity, treatment, and disposal of wastewater generated at these plants. This information was requested in data collection portfolios (dcp) mailed to all companies known or believed to belong to the nonferrous metals manufacturing category. A listing of the companies comprising the nonferrous metals industry (as classified by standard industrial code numbers) was compiled by consulting trade associations and the U.S. Bureau of Mines.

In all, dcp were sent to 540 firms (693 plants). In some cases, companies contacted were not actually members of the nonferrous metals manufacturing category as it is defined by the Agency. Where firms had nonferrous metals manufacturing operations at more than one location, a dcp was returned for each plant.

If the dcp was not returned, information on production processes, sources of wastewater and treatment technology at these plants was collected by telephone interview. The information so gathered was validated by sending a copy of the information recorded to the party consulted. The information was assumed to be correct as recorded if no reply was received in 30 days. In total, more than 99 percent of the category was contacted either by mail or by telephone.

A total of 450 dcp applicable to the nonferrous metals manufacturing category were returned. A breakdown of these facilities by type of metal processed is presented in Table III-1 (page 32).

The dcp responses were interpreted individually, and the following data were documented for future reference and evaluation:

Company name, plant address, and name of the contact listed in the dcp.

Plant discharge status as direct (to surface water), indirect (to POTW), or zero discharge.

Production process and waste streams present at the plant, as well as associated flow rates; production rates; operating hours; wastewater treatment, reuse, or disposal methods; and the quantity and nature of process chemicals.

Capital and annual wastewater treatment costs.

Availability of pollutant monitoring data provided by the plant.

The summary listing of this information provided a consistent, systematic method of evaluating and summarizing the dcp responses. In addition, procedures were developed to simplify subsequent analyses, which had the following capabilities:

Selection and listing of plants containing specific production process streams or treatment technologies.

Summation of the number of plants containing specific process waste streams and treatment combinations.

Calculation of the percent recycle present for specific waste streams and summation of the number of plants recycling these waste streams within various percent recycle ranges.

Calculation of annual production values associated with each process stream and summation of the number of plants with these process streams having production values within various ranges.

Calculation of water use and discharge from individual process streams.

The calculated information and summaries were used in developing these effluent limitations and standards. Summaries were used in the category profile, evaluation of subcategorization, and analysis of in-place treatment and control technologies. Calculated information was used in the determination of water use and discharge values for the conversion of pollutant concentrations to mass loadings.

GENERAL PROFILE OF THE NONFERROUS METALS MANUFACTURING CATEGORY

The nonferrous metals manufacturing point source category encom-

passes the primary smelting and refining of nonferrous metals (Standard Industrial Classification (SIC) 333) and the secondary smelting and refining of nonferrous metals (SIC 334). The category does not include the mining and concentration of ores, rolling, drawing, or extruding of metals, or scrap metal collection and preliminary grading.

Nonferrous metal manufacturers include processors of ore concentrates or other virgin materials (primary) and processors of scrap (secondary). Metals produced as by- or co-products of primary metals are themselves considered primary metals. For example, rhenium recovered from primary molybdenum roaster flue gases is considered to be primary rhenium, rather than secondary. Table III-1 (page 32) summarizes the nonferrous metals manufacturers studied by the type of metal processed.

The nonferrous metals manufacturing category is quite complex and the production process for a specific metal is dictated by the characteristics of raw materials, the economics of by-product recovery, and the process chemistry and metallurgy of the metals.

Employment data are given in the dcp responses for 456 plants. These plants report a total of 74,500 workers involved in nonferrous metals manufacturing plants. Industry production figures show that bauxite refining and primary aluminum dominates the industry in terms of tonnage. Other subcategories with large production figures are primary copper, lead, zinc and molybdenum.

Two hundred thirteen plants (47 percent) indicated that no wastewater from nonferrous metals manufacturing operations is discharged to either surface waters or a POTW. Of the remaining 243 plants, 112 (25 percent) discharge an effluent from nonferrous metals manufacturing directly to surface waters, and 131 (28 percent) discharge indirectly, sending nonferrous metals manufacturing effluent through a POTW.

EPA recognizes that plants sometimes combine process and non-process wastewater prior to treatment and discharge. Pollutant discharge allowances will be established under this regulation only for nonferrous metals manufacturing process wastewater, not the nonprocess wastewaters. The nonprocess flows and wastewater characteristics are a function of the plant layout and water handling practices. As a result, the pollutant discharge effluent limitation for nonprocess wastewater streams will be prepared by the permitting authority. A discussion of how a permit writer would construct a permit for a facility that combines wastewater is presented in Section IX.

Section III of each of the subcategory supplements presents a detailed profile of the plants in each subcategory and describes the production processes involved. In addition, the following specific information is presented:

1. Raw materials,
2. Manufacturing process,

3. Geographic locations of manufacturing plants,
4. Age of plants by discharge status,
5. Production ranges by discharge status, and
6. Summary of waste streams for each process.

Table III-1

SUMMARY OF DCP RESPONDENTS BY TYPE OF METAL PROCESSED

<u>Subcategory</u>	<u>Number of Plants</u>
Bauxite Refining	8
Primary Aluminum Smelting	33
Secondary Aluminum Smelting	59
Primary Copper Smelting	21
Primary Electrolytic Copper Refining	17
Secondary Copper	31
Primary Lead	9
Secondary Lead	73
Primary Zinc	8
Primary Tungsten	18
Primary Columbium-Tantalum	5
Secondary Silver	81
Metallurgical Acid Plants	29
Primary Antimony	8
Primary Beryllium	2
Primary and Secondary Germanium and Gallium	5
Secondary Indium	1
Secondary Mercury	4
Primary Molybdenum and Rhenium	9
Secondary Molybdenum and Vanadium	1
Primary Nickel and Cobalt	1
Secondary Nickel	2
Primary Precious Metals and Mercury	8
Secondary Precious Metals	49
Primary Rare Earth Metals	4
Secondary Tantalum	3
Secondary Tin	12
Primary and Secondary Titanium	8
Secondary Tungsten and Cobalt	6
Secondary Uranium	3
Primary Zirconium and Hafnium	3
	<hr/>
TOTAL	521

SECTION IV

INDUSTRY SUBCATEGORIZATION

Subcategorization should take into account pertinent industry characteristics, manufacturing process variations, wastewater characteristics, and other factors. Effluent limitations and standards establish mass limitations on the discharge of pollutants which are applied, through the permit issuance process, to specific dischargers. To allow the national standard to be applied to a wide range of sizes of production units, the mass of pollutant discharge must be referenced to a unit of production. This factor is referred to as a production normalizing parameter and is developed in conjunction with subcategorization.

Division of the category into subcategories provides a mechanism for addressing process and product variations which result in distinct wastewater characteristics. The selection of production normalizing parameters provides the means for compensating for differences in production rates among plants with similar products and processes within a uniform set of mass-based effluent limitations and standards.

This subcategorization analysis is actually an ongoing process. The first subcategories (bauxite refining, primary aluminum smelting, and secondary aluminum smelting) were established in a 1973 Agency rulemaking. Since that time, some subcategories have been modified. New subcategories were added in 1975 and then again in 1980.

A comprehensive analysis of each factor that might warrant separate limitations for different segments of the industry has led the Agency to promulgate the following subcategorization scheme for BPT and BAT effluent limitations guidelines and PSNS, PSES, and NSPS in the nonferrous metals manufacturing category. (See listing in Table V-1, page 48)

Most of these subcategories are further segmented into subdivisions for the development of effluent limitations; these subdivisions are enumerated and discussed in the subcategory supplements to this document.

SUBCATEGORIZATION BASIS

Technology-based effluent limitations are based primarily upon the treatability of pollutants in wastewaters generated by the category under review. The treatability of these pollutants is, of course, directly related to the flow and characteristics of the untreated wastewater, which in turn can be affected by factors inherent to a processing plant in the category. Therefore, these factors and the degree to which each influences wastewater flow and characteristics form the basis for subcategorization of the category, i.e., those factors which have a strong influence

on untreated wastewater flow and characteristics are applied to the category to subcategorize it in an appropriate manner.

The list of potential subcategorization factors considered for the nonferrous metals manufacturing category include:

- Metal products, co-products, and by-products;
- Raw materials;
- Manufacturing processes;
- Product form;
- Plant location;
- Plant age;
- Plant size;
- Air pollution control methods;
- Meteorological conditions;
- Treatment costs;
- Solid waste generation and disposal;
- Number of employees;
- Total energy requirements (manufacturing process and wastewater treatment and control); and
- Unique plant characteristics.

For the reasons discussed below, the metal or other products, the raw materials, and the manufacturing process were discovered to have the greatest influence on wastewater flow characteristics and treatability, and thus ultimately on the appropriateness of effluent limitations. These three factors were used to subcategorize the category. As mentioned previously, further division of some subcategories is warranted based on the sources of waste waters (manufacturing processes) within the plant. Each manufacturing process generates differing amounts of wastewater and in some instances specific waste streams contain pollutants requiring preliminary treatment to reduce concentrations of oil and grease, ammonia, cyanide, and toxic organics prior to combined treatment. Thus, each subcategory is further subdivided based on the manufacturing processes used. These subdivisions are discussed in the appropriate supplement.

Metal Products, Co-Products, and By-Products

The metal products, co-products, and by-products is the most important factor in identifying subcategories for this category. Subcategorizing on this basis is consistent with the existing division of plants, i.e., plants are identified as (and identify themselves as) nickel plants, tin plants, titanium plants, etc. The production of each metal is based on its own raw materials and production processes, which directly affect wastewater volume and characteristics.

In nonferrous metals manufacturing, production and refining of metal by-products and co-products generally will be covered by means of subcategorization with the major metal product. There are several examples of this. EPA found that production of the co-product metals primary zirconium and hafnium are inherently allied, so both were considered in a single subcategory. The

same is true for primary molybdenum and rhenium, primary nickel and cobalt, primary precious metals and mercury, and primary rare earth metals. Secondary cobalt is a by-product of the secondary tungsten manufacturing process, thus, the two are placed together in one subcategory.

Raw Materials

The raw materials used (ore concentrates or scrap) in nonferrous metals manufacturing determine the reagents used, and to a large extent the wastewater characteristics. Raw materials are significant in differentiating between primary and secondary producers. It is therefore selected as a basis for subcategorization. In some cases (e.g., primary and secondary titanium), the raw material differences did not warrant separate subcategorization due to common processing steps or other factors.

Manufacturing Processes

The production processes for each metal are unique and are affected by the raw materials used and the type of end product. The processes used will, in turn, affect the volume and characteristics of the resulting wastewater.

The processes performed (or the air pollution controls used on the process emissions) in the production of nonferrous metals determine the amount and characteristics of wastewater generated and thus are a logical basis for the establishment of subcategories. In this category, however, similar processes may be applied to differing raw materials in the production of different metals yielding different wastewater characteristics. For example, molybdenum, precious metals, and tin may all be produced by roasting. As a result of these considerations, specific process operation was not generally found to be suitable as a primary basis for subcategorization. However, process variations which result in significant differences in wastewater generation are reflected in the allowances for discrete unit operations within each subcategory (see the discussion of building blocks in Section IX).

In the case of primary copper manufacturing, the production processes used are deemed to be a reasonable basis for subcategorization, even though these processes are sometimes practiced at a single site. This resulted in the establishment of the primary copper smelting subcategory and the primary copper electrolytic refining subcategory (see Section IV of the Primary Copper Supplement). This is consistent with the structure of the category since smelting and refining are often conducted at different sites.

Product Form

This factor becomes important when the final product from a plant is actually an intermediate that another plant purchases and processes to render the metal in a different form. An example of

this is the production of molybdenum, which some plants produce by reducing molybdenum trioxide (MoO_3), an intermediate that may have been produced by another plant. This practice, however, is not found to be common in the category and its effect on wastewater volume and total subcategory raw waste generation is not as significant as the factors chosen.

Plant Location

Most plants in the category are located near raw materials sources, transportation centers, markets, or sources of inexpensive energy. While larger primary copper, lead, zinc, molybdenum and titanium producers are mainly found near Mid-western and Western ores and are remote from population centers, proximity to shipping lanes in the lower Mississippi region is important for bauxite refiners. Secondary producers, on the other hand, are generally located in or near large metropolitan areas. Therefore, primary producers often have more land available for treatment systems than secondary producers. Plant location also may be significant because evaporation ponds can be used only where solar evaporation is feasible and where sufficient land is available. However, location does not significantly affect wastewater characteristics or treatability, and thus different effluent limitations are not warranted based on this factor.

Plant Age

Plants within a given subcategory may have significantly different ages in terms of initial operating year. To remain competitive, however, plants must be constantly modernized.

Plants may be updated by modernizing a particular component, or by installing new components. For example, an old furnace might be equipped with oxygen lances to increase the throughput, or replaced entirely by a new, more efficient furnace. Modernization of production processes and air pollution control equipment produces analogous wastes among all plants producing a given metal, despite the original plant start-up date. While the relative age of a plant may be important in considering the economic impact of a guideline, as a subcategorization factor it does not account for differences in the raw wastewater characteristics. For these reasons, plant age is not selected as a basis for subcategorization.

Plant Size

The size of a plant generally does not affect either the production methods or the wastewater characteristics. Generally, more water is used at larger plants. However, when water use and discharge are normalized on a production basis, no major differences based on plant size are found within the same subcategory. Thus, plant size is not selected as a basis for subcategorization.

Air Pollution Control Methods

Many facilities use wet scrubbers to control emissions which influence wastewater characteristics. In some cases, the type of air pollution control equipment used provides a basis for regulation, because if wet air pollution control is used, an allowance may be necessary for that waste stream, while a plant using only dry systems does not need an allowance for a non-existent waste stream. Therefore, this factor is often selected as a basis for subdivision within some subcategories (i.e., developing an allowance for this unit operation as part of the limitation or standard for the subcategory), but not as a means for subcategorizing the category.

Meteorological Conditions

Climate and precipitation may affect the feasibility of certain treatment methods, e.g., solar evaporation through the use of impoundments is a feasible method of wastewater treatment only in areas of net evaporation. This factor was not selected for subcategorization, however, because the differences in wastewater characteristics and treatability are better explained by other factors such as metal products and manufacturing processes. Therefore, different effluent limitations based on this factor are not warranted.

Solid Waste Generation and Disposal

Physical and chemical characteristics of solid waste generated by the nonferrous metals category are determined by the raw material, process, and type of air pollution control in use. Therefore, this factor does not provide a primary basis for subcategorization.

Number of Employees

The number of employees in a plant does not directly provide a basis for subcategorization because the number of employees does not directly affect the production or process water usage rate at any plant. Because the amount of process wastewater generated is related to the production rates rather than employee number, the number of employees does not provide a definitive relationship to wastewater generation.

Total Energy Requirements

Total energy requirements was not selected as a basis for subcategorization primarily because energy requirements are found to vary widely within this category and are not meaningfully related to wastewater generation and pollutant discharge. Additionally, it is often difficult to obtain reliable energy estimates specifically for production and waste treatment. When available, estimates are likely to include other energy requirements such as lighting, air conditioning, and heating or cooling energy.

Unique Plant Characteristics

Unique plant characteristics such as land availability and water availability do not provide a proper basis for subcategorization because they do not materially affect the raw wastewater characteristics of the plant. Process water availability may indeed be a function of the geography of a plant. However, the impact of limited water supplies is to encourage conservation by recycle and efficient use of water. Therefore, insufficient water availability only tends to encourage the early installation of practices that are advisable for the entire category in order to reduce treatment costs and improve pollutant removals.

Limited land availability for constructing a waste treatment facility may affect the economic impact of an effluent limitation. The availability of land for treatment, however, is generally not a major issue in the nonferrous metals manufacturing category. Most primary plants are located on very large sites and land availability would not be a factor. While secondary producers tend to be located in more urban settings, the amount of land available to them for treatment is sufficient for the types of treatment and control technologies considered.

PRODUCTION NORMALIZING PARAMETERS

To ensure equitable regulation of the category, effluent guidelines limitations and standards of performance are established on a production-related basis (i.e., a mass of pollutant per unit of production). In addition, by using these mass-based limitations the total mass of pollutants discharged is minimized. The underlying premise for mass-based limitations is that pollutant loadings and water discharged from each process are correlated to the amount of material produced by that process. This correlation is calculated as the mass of pollutant or wastewater discharged per unit of production. The units of production are known as production normalizing parameters (PNPs). The type and value of the PNPs vary according to the subcategory or subdivision. In one case, it may be the total mass of metal produced from that line while in others it may be some other characteristic parameter. Two criteria are used in selecting the appropriate PNP for a given subcategory or subdivision: (1) maximizing the degree of correlation between the production of metal reflected by the PNP and the corresponding discharge of pollutants, and (2) ensuring that the PNP is easily measured and feasible for use in establishing regulations.

The production normalizing parameter identified for each subcategory or subdivision, and the rationale used in selection are discussed in detail in Section IV of the appropriate supplements.

SECTION V

WATER USE AND WASTEWATER CHARACTERISTICS

This section presents the data collection and data analysis methods used for characterizing water use and wastewater associated with the nonferrous metals manufacturing category. Raw waste and treated effluent sample data, and production normalized water use and wastewater discharge data are presented in Section V of each of the subcategory supplements.

DATA SOURCESHistorical Data

A useful source of long-term or historical data available for nonferrous metals manufacturing plants are the Discharge Monitoring Reports (DMR's) completed as a part of the National Pollutant Discharge Elimination System (NPDES). All applicable DMR's were obtained through the EPA regional offices and state regulatory agencies for the year 1982, the last complete year prior to the proposal of the first segment (Phase I) of this regulation for which information was available. These data were available from 14 nonferrous metals manufacturing plants. The DMR's present a summary of the analytical results from a series of samples taken during a given month for the pollutants designated in the plant's permit. In general, minimum, maximum, and average values, in mg/l or lbs/day, are presented for such pollutants as total suspended solids, aluminum, oil and grease, pH, copper, and zinc. The samples are collected from the plant outfall(s), which represents the discharge(s) from the plant. For facilities with wastewater treatment, the DMR's provide a measure of the performance of the treatment system. In theory, these data could then serve as a basis for characterizing treated wastewater from nonferrous metals manufacturing plants; however, there is no influent to treatment information (i.e., paired influent-effluent data) and too little information on the performance of the plant at the time the samples were collected to be the preferred source of data in formulating achievable performance for various types of treatment. They do serve as a set of data that can be used to verify the technology performances presented in Section VII, Control and Treatment Technology (Table VII-21, page 248). DMR data from 12 plants with lime precipitation and sedimentation treatment were used as a check on the achievability of the treatment effectiveness concentrations used to establish the limitations and standards. These DMR data and a comparison of them to the treatment effectiveness concentrations are found in the record of this rulemaking.

Data Collection Portfolios

Information on plant location and size, number of employees, dis-

charge status, production processes and quantities, wastewater sources and flows, treatment system processes, operations and costs, economic information, and pollutant characterization data was solicited in the data collection portfolio (dcp).

Two of the most important items are the production processes and quantities and the associated flows. These data were evaluated, and two flow-to-production ratios were calculated for each stream in each subcategory. The two ratios, water use and wastewater discharge flow, are differentiated by the flow value used in calculation. Water use is defined as the volume of water or other fluid required for a given process per mass of metal product and is therefore based on the sum of recycle and make-up flows to a given process. Wastewater flow discharged after preliminary treatment or recycle (if these are present) is the volume of wastewater discharged from a given process to further treatment, disposal, or discharge per mass of metal produced. The production values used in this calculation correspond to the production normalizing parameter, PNP, assigned to each stream, as outlined in Section IV of each of the subcategory supplements. This value is most often the amount of metal processed by each operation that generates a wastewater.

The production normalized water use and discharge flows were compiled and summarized for each stream. The flows are presented in Section V of each of the subcategory supplements. Where appropriate, an attempt was made to identify factors that could account for variations in water use. The flows for each stream were evaluated to establish BPT, BAT, NSPS, and pretreatment discharge flows. These are used in calculating the effluent limitations and standards in Sections IX, X, XI, and XII of each of the subcategory supplements.

The regulatory production normalized discharge flows were also used to estimate flows at nonferrous metals manufacturing plants that supplied EPA with only production data in their dcp. Actual discharge flows, or estimated flows, when an actual flow was not reported in the dcp, were then used to determine the cost of various wastewater treatment options at these facilities.

Sampling and Analysis Program

The sampling and analysis program discussed in this section was undertaken to collect specific data to implement the requirements of the 1977 amendments to the Act and to identify pollutants of concern in the nonferrous metals manufacturing point source category, with emphasis on toxic pollutants. EPA and its contractors collected and analyzed samples from 84 nonferrous metals manufacturing facilities.

This section summarizes the purpose of the sampling trips and identifies the parameters analyzed. It also presents an overview of sample collection, preservation, and transportation techniques. Finally, it describes the pollutant parameters quantified, the methods of analyses and laboratories used, the

detectable concentration of each pollutant, and the general approach used to ensure the reliability of the analytical data produced.

Site Selection. Information gathered in the data collection portfolios was used to select sites for wastewater sampling for each subcategory. The plants sampled were selected to be representative of each subcategory. Considerations included how well each facility represented the subcategory as indicated by available data, potential problems in meeting technology-based standards, differences in production processes used, number and variety of unit operations generating wastewater, and wastewater treatment in place. Additional details on site selection are presented in Section V of each of the subcategory supplements.

Field Sampling. After plants to be sampled were selected, each plant was contacted by telephone, and sent a letter of notification as to when a visit would be expected. These telephone inquiries disclosed facility information necessary for efficient on-site sampling. Based on this information, the sources of wastewater to be sampled at each plant were selected. The sample points included, but were not limited to, untreated and treated discharges, process wastewater, and partially treated wastewater.

During this program, 84 nonferrous metals manufacturing plants were sampled. The distribution of these plants by subcategory is presented in Table V-1 (page 48).

Wastewater samples were collected in three stages. In the first stage, 30 plants were sampled in an attempt to characterize all the significant waste streams and production processes in these industries. In the second stage, 46 plants were sampled in an attempt to fill any gaps in the data base, and to confirm data acquired during the first phase of sampling. In the third stage, EPA conducted a small plant self-sampling effort under Section 308 of the Clean Water Act. In this effort eight plants submitted data on specific waste streams for which EPA had not previously acquired analytical data. These data were used to confirm assumptions made by EPA in developing the limitations. Samples were generally analyzed for 124 (excluding TCDD and asbestos) of the 126 toxic pollutants and other pollutants deemed appropriate. Because no analytical standard was available for TCDD, samples were never analyzed for this pollutant, although there is no reason that it would be present in nonferrous metals manufacturing wastewater. Also, no samples were analyzed for asbestos because there is no reason to believe that asbestos would be present in wastewater resulting from the manufacture of nonferrous metals. At least one plant in every major subcategory was sampled during the data collection effort, with some subcategories sampled at more than one plant, when the production processes were different.

To reduce the volume of data handled, avoid unnecessary expense, and direct the scope of the sampling program, analyses were only

performed for pollutants expected to be present in a plant's wastewater. Two sources of information were used for selecting the analyzed pollutants: the pollutants that industry believes or knows are present in their wastewater, and the pollutants the Agency believes could be present after studying the processes and materials used by the industry. If industry and the Agency did not believe a pollutant or class of pollutants likely to be present in the wastewater after studying the processes and materials used, analyses for that pollutant were not completed.

The 126 toxic pollutants were listed in each dcp and each facility was asked to indicate for each particular pollutant whether it was known to be present or believed to be present. If the pollutant had been analyzed for and detected, the facility was to indicate that it was known to be present. If the pollutant had not been analyzed, but might be present in the wastewater, the facility was to indicate that it was believed to be present. The reported results are tabulated in Section V of the subcategory supplements.

Sample Collection, Preservation, and Transportation. Samples were collected, preserved, and transported in accordance with procedures outlined in Appendix III of "Sampling and Analysis Procedures for Screening of Industrial Effluents for Priority Pollutants" (published by the Environmental Monitoring and Support Laboratory, Cincinnati, Ohio, March 1977, revised, April 1977), "Sampling Screening Procedure for the Measurement of Priority Pollutants" (published by the EPA Effluent Guidelines Division, Washington, D.C., October 1976), Handbook for Sampling and Sample Preservation of Water and Wastewater (published by the Environmental Monitoring and Support Laboratory, Cincinnati, Ohio, September 1982) and in "Methods for Chemical Analysis of Water and Wastes", USEPA, EMSL, Cincinnati, Ohio 45268, EPA-600/4-79-020 (March 1983); "Guidelines Establishing Test Procedures for the Analysis of Pollutants Under the Clean Water Act", 49 FR 43234 (October 26, 1984). The procedures are summarized below.

Whenever practical, all samples collected at each sampling point were taken from mid-channel at mid-depth in a turbulent, well-mixed portion of the waste stream. Periodically, the temperature and pH of each waste stream sampled were measured onsite.

Before collection of automatic composite samples, new Tygon tubing was cut to minimum lengths and installed on the inlet and outlet (suction and discharge) fittings of the automatic sampler. Two liters (2.1 quarts) of blank water, known to be free of organic compounds and brought to the sampling site from the analytical laboratory, were pumped through the sampler and its attached tubing into a 3.8 liter (1 gallon) glass jug; the water was then distributed to cover the interior of the jug and subsequently discarded.

A field blank sample was produced by pumping an additional three liters (0.8 gal) of blank water through the sampler into the

glass jug. The blank sample was sealed with a Teflon-lined cap, labeled, and packed in ice in a plastic foam-insulated chest. This sample subsequently was analyzed to determine any contamination contributed by the automatic sampler.

Each large composite (Type 1) sample was collected in a 10-liter (2.6 gallon) wide-mouth glass jar that had been washed with detergent and water, rinsed with tap water, rinsed with distilled water and then methylene chloride, and air dried at room temperature in a dust-free environment.

During collection of each Type 1 sample, the wide-mouth glass jar was packed in ice in a separate plastic foam-insulated container. After the complete composite sample had been collected, it was mixed to provide a homogenous mixture, and 1-liter aliquots were removed for metals analysis and placed in two new labeled plastic 1-liter bottles which had been rinsed with distilled water. Both of the 1-liter aliquots were preserved by the addition of 5 ml of concentrated nitric acid. The bottles were then sealed, placed in an insulated chest and shipped for metals analyses. These analyses include atomic absorption spectrophotometry and inductively coupled argon plasma emission spectroscopy (ICAP).

After removal of the two 1-liter metals aliquots from the composite sample, the balance of the sample in the glass jar was subdivided for analysis of nonvolatile organics, conventional, and nonconventional parameters. If a portion of this sample was requested by a plant representative for independent analysis, a 1-liter aliquot was placed in a sample container supplied by the representative.

Sample Types 2 (cyanide) and 3 (total phenols) were stored in new bottles which had been iced and labeled; 1-liter clear plastic bottles for Type 2, and 1-liter amber glass for Type 3. The bottles had been cleaned by rinsing with distilled water, and the samples were preserved as described below.

To each Type 2 (cyanide) sample, sodium hydroxide was added as necessary to elevate the pH to 12 or more (as measured using pH paper). Where the presence of chlorine (which would decompose most of the cyanide) was suspected, the sample was tested for chlorine by using potassium iodide-starch paper. If the paper turned blue, ascorbic acid crystals were slowly added and dissolved until a drop of the sample produced no change in the color of the test paper. An additional 0.6 gram (0.021 ounce) of ascorbic acid was added, and each sample bottle was sealed (by a Teflon-lined cap), labeled, iced, and shipped for analysis.

To each Type 3 (total phenols) sample, sulfuric acid was added as necessary to reduce the pH to 2 or less (as measured using pH paper). Each sample bottle was sealed with a Teflon-lined cap, labeled, iced, and shipped for analysis.

Each Type 4 (volatile organics) sample was stored in a new 40-ml

glass vial that had been rinsed with tap water and distilled water, heated to 105°C (221°F) for one hour, and cooled. The septum and lid for each bottle were also prepared by this method. Each bottle, when used, was filled to overflowing, sealed with a Teflon-faced silicone septum (Teflon side down), capped; labeled, and iced. Proper sealing was verified by inverting and tapping the container to confirm the absence of air bubbles. (If bubbles were found, the bottle was opened, a few additional drops of sample were added, and proper sealing was verified.) Samples were labeled, iced to 4°C, and sent for analysis.

A 1-quart wide-mouth glass bottle was used to collect each grab sample for oil and grease analysis. Because oil tends to form a film on top of water in quiescent streams, the sample was collected in an area of complete mixing. Sulfuric acid was added as necessary to reduce the pH to less than 2. The sample bottle was sealed with a Teflon-lined cap, labeled, iced to 4°C and shipped for analysis.

Sample Analysis. Samples were shipped by air to laboratories where inductively coupled argon plasma emission spectroscopy (ICAP) and atomic absorption spectrophotometry (AA) analyses were performed. The samples were analyzed only for metals shown to be significant in the nonferrous metals manufacturing category or those expected to consume large amounts of lime. Twenty-three metals were analyzed by ICAP, and six metals were analyzed by AA, as shown below. Total metals analysis was used for all samples.

Two nonconventional metal pollutants (tantalum and tungsten) were analyzed by X-ray fluorescence. Uranium was analyzed by fluorometry.

Metals Analyzed by ICAP

Aluminum	Magnesium
Barium	Manganese
*Beryllium	Molybdenum
Boron	*Nickel
*Cadmium	Sodium
Calcium	Tin
*Chromium	Titanium
Cobalt	Vanadium
*Copper	Yttrium
Gold	*Zinc
Iron	Zirconium
*Lead	

Metals Analyzed by AA

*Antimony	*Selenium
*Arsenic	*Silver
*Mercury	*Thallium

Metals Analyzed by X-Ray Fluorescence

Tantalum
Tungsten

Metals Analyzed by Fluorometry

Uranium

*Priority pollutant metals.

Mercury was analyzed by cold vapor flameless atomic absorption spectrophotometry.

Radium-226 was analyzed by the precipitation method. The reference for this method is the Interim Radiochemical Methodology.

Samples also went to laboratories for organics analysis. Due to their very similar physical and chemical properties, it is extremely difficult to separate the seven polychlorinated biphenyls (pollutants 106 to 112) for analytical identification and quantification. For that reason, the concentrations of the polychlorinated biphenyls are reported by the analytical laboratory in two groups: one group consists of PCB-1222, PCB-1252, and PCB-1221; the other group consists of PCB-1232 PCB-1248, PC8-1260, and PCB-1016. For convenience, the first group has been referred to as PCB-1254 and the second as PCB-1228.

The samples were not analyzed for Pollutant 129, 2,3,7,8-tetrachlorodibenzo-p-dioxin (TCDD) because no reference sample was available to the analytical laboratory.

Three of the five conventional pollutant parameters were selected for analysis for evaluating treatment system performance. They are total suspended solids (TSS), oil and grease, and pH. The other two conventionals, fecal coliform and biochemical oxygen demand (BOD), were not measured because there is no reason to believe that fecal matter or oxygen demanding biological materials would be present in these wastewaters. Ammonia, fluoride, and total phenols (4-AAP) were analyzed for in selected samples if there was reason to believe they would be present based on the processes used. While not classified as toxic pollutants, they affect the water quality. Chemical oxygen demand (COD) and total organic carbon (TOC) were also selected for analysis for selected samples for subsequent use in evaluating treatment system performance. Total dissolved solids (TDS) was measured to evaluate the potential for accumulation of dissolved salts.

In addition, chloride, alkalinity-acidity, total solids, total phosphorus (as PO₄), and sulfate were measured to provide data to evaluate the performance and cost of lime and settle treatment of certain wastewater streams.

Samples were also analyzed for asbestos by transmission electron microscopy. Total fiber and chrysotile fiber counts were

reported by the testing laboratory. Chrysotile was chosen by the Agency as the screening parameter for asbestos for mining related activities because: (1) of its known toxicity when particles are inhaled, (2) its industrial prevalence, (3) its distinguishing selected area electron diffraction (SAED) pattern, and (4) the cumbersome nature of the transmission electron microscopic (TEM) analysis technique limits the identification to one mineral form at the present time due to economics and time constraints.

While the asbestos data vary, the testing laboratory's report indicates that when the total fiber count is performed in conjunction with a count of chrysotile fibers, a good initial screening parameter is produced. The report recommends re-examining any facility with chrysotile fiber counts greater than 100 million fibers per liter (MFL) because this represents a significant departure from ambient counts of 3 MFL in the Great Lakes Basin. The technique used had a threshold of detection of 0.22 MFL.

The analytical quantification limits used in evaluation of the sampling data reflect the accuracy of the analytical methods used. Below these concentration, the identification of the individual compounds is possible, but quantification is difficult. Pesticides and PCBs can be analytically quantified at concentrations above 0.005 mg/l, and other organic priority pollutants at concentrations above 0.010 mg/l. Analytical quantification limits associated with priority inorganic pollutants are as follows: 0.100 mg/l for antimony; 0.10 mg/l for arsenic; 10 MFL for asbestos; 0.010 mg/l for beryllium; 0.002 mg/l for cadmium; 0.005 mg/l for chromium; 0.009 mg/l for copper; 0.02 mg/l for cyanide; 0.02 mg/l for lead; 0.0001 mg/l for mercury; 0.005 mg/l for nickel; 0.010 mg/l for selenium; 0.020 mg/l for silver; 0.100 mg/l for thallium; and 0.050 mg/l for zinc.

These detection limits are not the same as published detection limits for these pollutants by the same analytical methods (40 CFR Part 136 - Guidelines Establishing Test Procedures for the Analysis of Pollutants; 40 CFR Part 136 - Proposed, 44 FR 69464, December 3, 1979; 1982 Annual Book of ASTM Standards, Part 31, Water, ASTM, Philadelphia, PA: "Methods for Chemical Analysis of Water and Wastes," Environmental Monitoring and Support Laboratory, Office of Research and Development, U.S. EPA Cincinnati, OH, March, 1979, EPA-600 4-79-020; Handbook for Monitoring Industrial Wastewater, U.S. EPA Technology Transfer, August, 1973). The detection limits used were reported with the analytical data and hence are the appropriate limits to apply to the data. Detection limit variation can occur as a result of a number of laboratory equipment and daily operator-specific factors, such as day-to-day differences in machine calibration, variation in stock solutions, and variation in operators.

Quality Control. Quality control measures used in performing all analyses conducted for this program complied with the guidelines given in "Handbook for Analytical Quality Control in Water and

Wastewater Laboratories" (published by EPA Environmental Monitoring and Support Laboratory, Cincinnati, Ohio, 1976). As part of the daily quality control program, blanks (including sealed samples of blank water carried to each sampling site and returned unopened, as well as samples of blank water used in the field), standards, and spiked samples were routinely analyzed with actual samples. As part of the overall program, all analytical instruments (such as balances, spectrophotometers, and recorders) were routinely maintained and calibrated.

The atomic-absorption spectrophotometer used for metal analysis was checked to see that it was operating correctly and performing within expected limits. Appropriate standards were included after at least every 10 samples. Reagent blanks were also analyzed for each metal.

WATER USE AND WASTEWATER CHARACTERISTICS

In each of the subcategory supplements, wastewater characteristics corresponding to the subcategories in the nonferrous metals manufacturing category are presented and discussed. Tables are presented in Section V of each of the subcategory supplements which present the sampling program data for raw waste and treated effluent sampled streams. For those pollutants detected above analytically quantifiable concentrations in any sample of a given wastewater stream, the actual analytical data are presented. Where no data are listed for a specific day of sampling, it indicates that the wastewater samples for the stream were not collected.

The statistical analysis of data includes some samples measured at concentrations considered not quantifiable. The base neutrals, acid fraction, and volatile organics are considered not quantifiable at concentrations equal to or less than 0.010 mg/l. Below this level, organic analytical results are not quantitatively accurate; however, the analyses are useful to indicate the presence of a particular pollutant. Nonquantifiable results are designated in the tables with an asterisk (double asterisk for pesticides).

When calculating averages from the organic sample data, non-quantifiable results and data reported as not detected (ND) were assumed to be zero. When calculating averages from metal, cyanide, conventional and nonconventional sampling data, values reported as less than a certain value were considered as not quantifiable, and consequently were assigned a value of zero.

Table V-1

DISTRIBUTION OF SAMPLED PLANTS IN THE NONFERROUS METALS
MANUFACTURING CATEGORY BY SUBCATEGORY

<u>Subcategory</u>	<u>Number of Plants</u>
Bauxite Refining	2
Primary Aluminum Smelting	7
Secondary Aluminum Smelting	5
Primary Copper Smelting	4
Secondary Copper	5
Primary Lead	3
Secondary Lead	8
Primary Zinc	6
Primary Tungsten	6
Primary Columbium-Tantalum	4
Secondary Silver	4
Metallurgical Acid Plants*	-
Primary Antimony	-
Primary Beryllium	1
Primary and Secondary Germanium and Gallium	2
Secondary Indium	1
Primary Magnesium**	1
Secondary Mercury	-
Primary Molybdenum and Rhenium (includes Molybdenum Acid Plants	3
Secondary Molybdenum and Vanadium	1
Primary Nickel and Cobalt	1
Secondary Nickel	1
Primary Precious Metals and Mercury	2
Secondary Precious Metals	5
Primary Rare Earth Metals	1
Secondary Tantalum	2
Secondary Tin	5
Primary and Secondary Titanium	3
Secondary Tungsten and Cobalt	2
Secondary Uranium	1
Primary Zirconium and Hafnium	2
 	<hr/>
TOTAL (!)	84

**The primary magnesium subcategory has been recommended for exclusion under Paragraph 8 of the Settlement Agreement.

*Acid plant wastewater samples were collected at the primary copper, lead, and zinc plants listed above.

!Because several plants were sampled for more than one subcategory, the actual number of plants sampled is less than the total number of plants sampled for all subcategories.

SECTION VI

SELECTION OF POLLUTANT PARAMETERS

The Agency has studied nonferrous metals manufacturing wastewaters to determine the presence or absence of toxic, conventional, and selected nonconventional pollutants. The toxic pollutants and nonconventional pollutants are subject to BAT effluent limitations and guidelines. Conventional pollutants are considered in establishing BPT, BCT, and NSPS limitations.

Sixty five pollutants and classes of pollutants were classified as toxic by the CWA amendments of 1977. The Agency clarified this into the list of 129 specific toxic pollutants listed in Table VI-1 (page 126) for which specific analysis procedures and standards were available. These 129 toxic pollutants are sometimes referred to as priority pollutants. Three pollutants have been deleted from the toxic pollutant list. Dichlorodifluoromethane and trichlorofluoromethane were deleted (46 FR 2266, January 8, 1981) followed by the deletion of bis-(chloromethyl) ether (46 FR 10723, February 4, 1981) The Agency has concluded that deleting these compounds will not compromise adequate control over their discharge into the aquatic environment and that no adverse effects on the aquatic environment or on human health will occur as a result of deleting them from the list of toxic pollutants.

Past studies by EPA and others have identified many pollutant parameters in addition to the toxic pollutants useful in characterizing industrial wastewaters and in evaluating treatment process removal efficiencies. For this reason, a number of other pollutants and pollutant parameters were also studied for the nonferrous metals manufacturing category.

The conventional pollutants considered in this rulemaking (total suspended solids, oil and grease, and pH) traditionally have been studied to characterize industrial wastewaters. These parameters impact water quality and are especially useful in evaluating the effectiveness of some wastewater treatment processes. EPA has defined the criteria for the selection of conventional pollutants (43 FR 32857 January 11, 1980).

Several nonconventional pollutants were also considered in developing these regulations. These include aluminum, barium, boron, cesium, cobalt, gallium, germanium, hafnium, manganese, radium-226, rhenium, rubidium, uranium, vanadium, zirconium, chemical oxygen demand (COD), and total organic carbon (TOC). In addition, calcium, chloride, magnesium, alkalinity-acidity, total dissolved solids, total phosphorus (as PO_4), and sulfate were measured to provide data to evaluate the cost of chemical precipitation and sedimentation treatment of certain wastewater streams.

Fluoride, ammonia (NH_3), and total phenols (4-AAP) were also identified as pollutants for some of the subcategories. Fluoride compounds are used in the production of primary aluminum, columbium-tantalum, and beryllium and secondary uranium and are present in the raw wastewater of these industries. NH_3 is used in the process or formed during a process step in the primary aluminum, columbium-tantalum, tungsten, and zirconium subcategories and in the secondary molybdenum and vanadium, precious metals, tungsten and cobalt, uranium, aluminum and silver subcategories. In other subcategories, it has been used for neutralization of the wastewater.

RATIONALE FOR SELECTION OF POLLUTANT PARAMETERS

In determining which pollutants to regulate, a pollutant that was never detected, or that was never found above its analytical quantification level, usually was eliminated from consideration. The analytical quantification level for a pollutant is the minimum concentration at which that pollutant can be reliably measured. Below that concentration, the identification of the individual compounds is possible, but quantification is difficult. For the priority pollutants in this study, the analytical quantification levels are: 0.005 mg/l for pesticides, PCB's, chromium, and nickel; 0.010 mg/l for the remaining organic priority pollutants and cyanide, arsenic, beryllium, and selenium; 10 million fibers per liter (10 MFL) for asbestos; 0.020 mg/l for lead and silver; 0.009 mg/l for copper; 0.002 mg/l for cadmium; and 0.0001 mg/l for mercury.

These detection limits are not the same as published detection limits for these pollutants by the same analytical methods. The detection limits used were reported with the analytical data and hence are the appropriate limits to apply to the data. Detection limit variation can occur as a result of a number of laboratory-specific, equipment-specific, and daily operator-specific factors. These factors can include day-to-day differences in machine calibration, variation in stock solutions, and variation in operators.

Because the analytical standard for TCDD was judged to be too hazardous to be made generally available, samples were never analyzed for this pollutant. There is no reason to expect that TCDD would be present in nonferrous metals manufacturing wastewaters.

Pollutants which were detected below concentrations considered achievable by available treatment technology were also eliminated from further consideration. For the toxic metals, the chemical precipitation, sedimentation, and filtration technology values, which are presented in Section VII (Table VII-21 page 248) were used. For the toxic organic pollutants detected above their analytical quantification limit, achievable concentrations for activated carbon technology were used. These concentrations represent the most stringent treatment options considered for pollutant removal.

The pollutant exclusion procedure was applied to the raw waste data for each subcategory. Detailed specific results are presented in Section VI of each of the subcategory supplements. Summary results of selected pollutants for each subcategory are presented later in this section.

Toxic pollutants remaining after the application of the exclusion process were then selected for further consideration in establishing specific regulations.

DESCRIPTION OF POLLUTANT PARAMETERS

The following discussion addresses the pollutant parameters detected above their analytical quantification limit in any sample of nonferrous metals manufacturing wastewater. The description of each pollutant provides the following information: the source of the pollutant; whether it is a naturally occurring element, processed material, or manufactured compound; general physical properties and the form of the pollutant; toxic effects of the pollutant in humans and other animals; and behavior of the pollutant in a POTW at concentrations that might be expected from industrial discharges.

Acenaphthene (1). Acenaphthene (1,2-dihydroacenaphthylene, or 1,8-ethylene-naphthalene) is a polynuclear aromatic hydrocarbon (PAH) with molecular weight of 154 and a formula of $C_{12}H_{10}$.

Acenaphthene occurs in coal tar produced during high temperature coking of coal. It has been detected in cigarette smoke and gasoline exhaust condensates.

The pure compound is a white crystalline solid at room temperature with a melting range of $95^{\circ}C$ to $97^{\circ}C$ and a boiling range of $278^{\circ}C$ to $280^{\circ}C$. Its vapor pressure at room temperature is less than 0.02 mm Hg. Acenaphthene is slightly soluble in water (100 mg/l), but even more soluble in organic solvents such as ethanol, toluene, and chloroform. Acenaphthene can be oxidized by oxygen or ozone in the presence of certain catalysts. It is stable under laboratory conditions.

Acenaphthene is used as a dye intermediate, in the manufacture of some plastics, and as an insecticide and fungicide.

So little research has been performed on acenaphthene that its mammalian and human health effects are virtually unknown. The water quality criterion of 0.02 mg/l is recommended to prevent the adverse effects on humans due to the organoleptic properties of acenaphthene in water.

No detailed study of acenaphthene behavior in a POTW is available. However, it has been demonstrated that none of the organic toxic pollutants studied so far can be broken down by biological treatment processes as readily as fatty acids, carbohydrates, or proteins. Many of the toxic pollutants have been investigated,

at least in laboratory-scale studies, at concentrations higher than those expected to be contained by most municipal wastewaters. General observations relating molecular structure to ease of degradation have been developed for all of the toxic organic pollutants.

The conclusion reached by study of the limited data is that biological treatment produces little or no degradation of acenaphthene. No evidence is available for drawing conclusions about its possible toxic or inhibitory effect on POTW operation.

Its water solubility would allow acenaphthene present in the influent to pass through a POTW into the effluent. The hydrocarbon character of this compound makes it sufficiently hydrophobic that adsorption onto suspended solids and retention in the sludge may also be a significant route for removal of acenaphthene from the POTW.

Acenaphthene has been demonstrated to affect the growth of plants through improper nuclear division and polyploidal chromosome number. However, it is not expected that land application of sewage sludge containing acenaphthene at the low concentrations which are to be expected in a POTW sludge would result in any adverse effects on animals ingesting plants grown in such soil.

Benzene (4). Benzene (C_6H_6) is a clear, colorless liquid obtained mainly from petroleum feedstocks by several different processes. Some is recovered from light oil obtained from coal carbonization gases. It boils at $80^{\circ}C$ and has a vapor pressure of 100 mm Hg at $26^{\circ}C$. It is slightly soluble in water (1.8 g/l at $25^{\circ}C$) and it dissolves in hydrocarbon solvents. Annual U.S. production is three to four million tons.

Most of the benzene used in the U.S. goes into chemical manufacture. About half of that is converted to ethylbenzene which is used to make styrene. Some benzene is used in motor fuels.

Benzene is harmful to human health according to numerous published studies. Most studies relate effects of inhaled benzene vapors. These effects include nausea, loss of muscle coordination, and excitement, followed by depression and coma. Death is usually the result of respiratory or cardiac failure. Two specific blood disorders are related to benzene exposure. One of these, acute myelogenous leukemia, represents a carcinogenic effect of benzene. However, most human exposure data are based on exposure in occupational settings and benzene carcinogenesis is not considered to be firmly established.

Oral administration of benzene to laboratory animals produced leukopenia, a reduction in number of leukocytes in the blood. Subcutaneous injection of benzene-oil solutions has produced suggestive, but not conclusive, evidence of benzene carcinogenesis.

Benzene demonstrated teratogenic effects in laboratory animals,

and mutagenic effects in humans and other animals.

For maximum protection of human health from the potential carcinogenic effects of exposure to benzene through ingestion of water and contaminated aquatic organisms, the ambient water concentration is zero. Concentrations of benzene estimated to result in additional lifetime cancer risk at levels of 10^{-7} , 10^{-6} , and 10^{-5} are 0.00015 mg/l, 0.0015 mg/l, and 0.015 mg/l, respectively.

Some studies have been reported regarding the behavior of benzene in a POTW. Biochemical oxidation of benzene under laboratory conditions, at concentrations of 3 to 10 mg/l, produced 24, 27, 24, and 20 percent degradation in 5, 10, 15, and 20 days, respectively, using unacclimated seed cultures in fresh water. Degradation of 58, 67, 76, and 80 percent was produced in the same time periods using acclimated seed cultures. Other studies produced similar results. Based on these data and general conclusions relating molecular structure to biochemical oxidation, it is expected that biological treatment in a POTW will remove benzene readily from the water. Other reports indicate that most benzene entering a POTW is removed to the sludge and that influent concentrations of 1m/l inhibit sludge digestion. There is no information about possible effects of benzene on crops grown in soils amended with sludge containing benzene.

Carbon Tetrachloride (6). Carbon tetrachloride (CCl_4), also called tetrachloromethane, is a colorless liquid produced primarily by the chlorination of hydrocarbons, particularly methane. Carbon tetrachloride boils at 77°C and has a vapor pressure of 90 mm Hg at 20°C . It is slightly soluble in water (0.8 gm/l at 25°C) and soluble in many organic solvents. Approximately one-third of a million tons is produced annually in the U.S.

Carbon tetrachloride, which was displaced by perchloroethylene as a dry cleaning agent in the 1930's, is used principally as an intermediate for production of chlorofluoromethanes for refrigerants, aerosols, and blowing agents. It is also used as a grain fumigant.

Carbon tetrachloride produces a variety of toxic effects in humans. Ingestion of relatively large quantities - greater than 5 grams - has frequently proved fatal. Symptoms are burning sensation in the mouth, esophagus, and stomach, followed by abdominal pains, nausea, diarrhea, dizziness, abnormal pulse, and coma. When death does not occur immediately, liver and kidney damage are usually found. Symptoms of chronic poisoning are not as well defined. General fatigue, headache, and anxiety have been observed, accompanied by digestive tract and kidney discomfort or pain.

Data concerning teratogenicity and mutagenicity of carbon tetrachloride are scarce and inconclusive. However, carbon tetrachloride has been demonstrated to be carcinogenic in laboratory

animals. The liver was the target organ.

For maximum protection of human health from the potential carcinogenic effects of exposure to carbon tetrachloride through ingestion of water and contaminated aquatic organisms, the ambient water concentration is zero. Concentrations of carbon tetrachloride estimated to result in additional lifetime cancer risk at risk levels of 10^{-7} , 10^{-6} , and 10^{-5} are 0.000026 mg/l, 0.00026 mg/l, and 0.0026 mg/l, respectively.

Data on the behavior of carbon tetrachloride in a POTW are not available. Many of the toxic organic pollutants have been investigated, at least in laboratory-scale studies, at concentrations higher than those expected to be found in most municipal wastewaters. General observations have been developed relating molecular structure to ease of degradation for all of the toxic organic pollutants. The conclusion reached by study of the limited data is that biological treatment produces a moderate degree of removal of carbon tetrachloride in a POTW. No information was found regarding the possible interference of carbon tetrachloride with treatment processes. Based on the water solubility of carbon tetrachloride, and the vapor pressure of this compound, it is expected that some of the undegraded carbon tetrachloride will pass through to the POTW effluent and some will be volatilized in aerobic processes.

Chlorobenzene (7). Chlorobenzene (C_6H_5Cl), also called monochlorobenzene is a clear, colorless, liquid manufactured by the liquid phase chlorination of benzene over a catalyst. It boils at $132^\circ C$ and has a vapor pressure of 12.5 mm Hg at $25^\circ C$. It is almost insoluble in water (0.5 g/l at $30^\circ C$), but dissolves in hydrocarbon solvents. U.S. annual production is near 150,000 tons.

Principal uses of chlorobenzene are as a solvent and as an intermediate for dyes and pesticides. Formerly it was used as an intermediate for DDT production, but elimination of production of that compound reduced annual U.S. production requirements for chlorobenzene by half.

Data on the threat to human health posed by chlorobenzene are limited. Laboratory animals, administered large doses of chlorobenzene subcutaneously, died as a result of central nervous system depression. At slightly lower dose rates, animals died of liver or kidney damage. Metabolic disturbances occurred also. At even lower dose rates of orally administered chlorobenzene similar effects were observed, but some animals survived longer than at higher dose rates. No studies have been reported regarding evaluation of the teratogenic, mutagenic, or carcinogenic potential of chlorobenzene.

For the prevention of adverse effects due to the organoleptic properties of chlorobenzene in water the recommended criterion is 0.020 mg/l.

Only limited data are available on which to base conclusions about the behavior of chlorobenzene in a POTW. Laboratory studies of the biochemical oxidation of chlorobenzene have been carried out at concentrations greater than those expected to normally be present in POTW influent. Results showed the extent of degradation to be 25, 28, and 44 percent after 5, 10, and 20 days, respectively. In another, similar study using a phenol-adapted culture, 4 percent degradation was observed after 3 hours with a solution containing 80 mg/l. On the basis of these results and general conclusions about the relationship of molecular structure to biochemical oxidation, it is concluded that chlorobenzene remaining intact is expected to volatilize from the POTW in aeration processes. The estimated half-life of chlorobenzene in water based on water solubility, vapor pressure and molecular weight is 5.8 hours.

1,2,4-Trichlorobenzene (8). 1,2,4-Trichlorobenzene ($C_6H_3Cl_3$), 1,2,4-TCB) is a liquid at room temperature, solidifying to a crystalline solid at $17^\circ C$ and boiling at $214^\circ C$. It is produced by liquid phase chlorination of benzene in the presence of a catalyst. Its vapor pressure is 4 mm Hg at $25^\circ C$. 1,2,4-TCB is insoluble in water and soluble in organic solvents. Annual U.S. production is in the range of 15,000 tons. 1,2,4-TCB is used in limited quantities as a solvent and as a dye carrier in the textile industry. It is also used as a heat transfer medium and as a transfer fluid. The compound can be selectively chlorinated to 1,2,4,5-tetrachlorobenzene using iodine plus antimony trichloride as catalyst.

No reports were available regarding the toxic effects of 1,2,4-TCB on humans. Limited data from studies of effects in laboratory animals fed 1,2,4-TCB indicate depression of activity at low doses and predeath extension convulsions at lethal doses. Metabolic disturbances and liver changes were also observed. Studies for the purpose of determining teratogenic or mutagenic properties of 1,2,4-TCB have not been conducted. No studies have been made of carcinogenic behavior of 1,2,4-TCB administered orally.

For the prevention of adverse effects due to the organoleptic properties of 1,2,4-trichlorobenzene in water, the water quality criterion is 0.013 mg/l.

Data on the behavior of 1,2,4-TCB in POTW are not available. However, this compound has been investigated in a laboratory scale study of biochemical oxidation at concentrations higher than those expected to be contained by most municipal wastewaters. Degradations of 0, 87, and 100 percent were observed after 5, 10, and 20 days, respectively. Using this observation and general observations relating molecular structure to ease of degradation for all of the organic priority pollutants, the conclusion was reached that biological treatment produces a high degree of removal in POTW.

Hexachlorobenzene (9). Hexachlorobenzene (C_6H_6) is a non-

flammable crystalline substance which is virtually insoluble in water. However, it is soluble in benzene, chloroform, and ether. Hexachlorobenzene (HCB) has a density of 2.044 g/ml. It melts at 231°C and boils at 323 to 326°C. Commercial production of HCB in the U.S. was discontinued in 1976, though it is still generated as a by-product of other chemical operations. In 1972, an estimated 2,425 tons of HCB were produced in this way.

Hexachlorobenzene is used as a fungicide to control fungal diseases in cereal grains. The main agricultural use of HCB is on wheat seed intended solely for planting. HCB has been used as an impurity in other pesticides. It is used in industry as a plasticizer for polyvinyl chloride as well as a flame retardant.

HCB is also used as a starting material for the production of pentachlorophenol which is marketed as a wood preservative.

Hexachlorobenzene can be harmful to human health as was seen in Turkey from 1955 to 1959. Wheat that had been treated with HCB in preparation for planting was consumed as food. Those people affected by HCB developed cutanea tarda porphyria, the symptoms of which included blistering and epidermolysis of the exposed parts of the body, particularly the face and the hands. These symptoms disappeared after consumption of HCB contaminated bread was discontinued. However, the HCB which was stored in body fat contaminated maternal milk. As a result of this, at least 95 percent of the infants feeding on this milk died. The fact that HCB remains stored in body fat after exposure has ended presents an additional problem. Weight loss may result in a dramatic redistribution of HCB contained in fatty tissue. If the stored levels of HCB are high, adverse effects might ensue.

Limited testing suggests that hexachlorobenzene is not teratogenic or mutagenic. However, two animal studies have been conducted which indicate that HCB is a carcinogen. HCB appears to have multipotential carcinogenic activity; the incidence of hepatomas, haemangioendotheliomas and thyroid adenomas was significantly increased in animals exposed to HCB by comparison to control animals.

For maximum protection of human health from the potential carcinogenic effects of exposure to hexachlorobenzene through ingestion of water and contaminated aquatic organisms, the ambient water concentration is zero. Concentrations of HCB estimated to result in additional lifetime cancer risk at levels of 10^{-7} , 10^{-6} , and 10^{-5} are 7.2×10^{-8} mg/l, 7.2×10^{-7} mg/l, and 7.2×10^{-6} mg/l, respectively. If contaminated aquatic organisms alone are consumed, excluding the consumption of water, the water concentration should be less than 7.4×10^{-6} mg/l to keep the increased lifetime cancer risk below 10^{-5} . Available data show that adverse effects on aquatic life occur at concentrations higher than those cited for human health risks.

No detailed study of hexachlorobenzene behavior in POTW is available. However, general observations relating molecular

structure to ease of degradation have been developed for all of the organic priority pollutants. The conclusion reached by study of the limited data is that biological treatment produces little or no degradation of hexachlorobenzene. No evidence is available for drawing conclusions regarding its possible toxic or inhibitory effect on POTW operations.

1,2-Dichloroethane (10). 1,2-Dichloroethane is a halogenated aliphatic used in the production of tetraethyl lead and vinyl chloride, as an industrial solvent, and as an intermediate in the production of other organochlorine compounds. Some chlorinated ethanes have been found in drinking waters, natural waters, aquatic organisms, and foodstuffs. Research indicates that they may have mutagenic and carcinogenic properties.

1,1,1-Trichloroethane (11). 1,1,1-Trichloroethane is one of the two possible trichloroethanes. It is manufactured by hydrochlorinating vinyl chloride to 1,1-dichloroethane which is then chlorinated to the desired product. 1,1,1-Trichloroethane is a liquid at room temperature with a vapor pressure of 96 mm Hg at 20°C and a boiling point of 74°C. Its formula is CCl_3CH_3 . It is slightly soluble in water (0.48 g/l) and is very soluble in organic solvents. U.S. annual production is greater than one-third of a million tons.

1,1,1-Trichloroethane is used as an industrial solvent and degreasing agent.

Most human toxicity data for 1,1,1-trichloroethane relates to inhalation and dermal exposure routes. Limited data are available for determining toxicity of ingested 1,1,1-trichloroethane, and those data are all for the compound itself, not solutions in water. No data are available regarding its toxicity to fish and aquatic organisms. For the protection of human health from the toxic properties of 1,1,1-trichloroethane ingested through the consumption of water and fish, the ambient water criterion is 15.7 mg/l. The criterion is based on bioassays for possible carcinogenicity.

No detailed study of 1,1,1-trichloroethane behavior in a POTW is available. However, it has been demonstrated that none of the toxic organic pollutants of this type can be broken down by biological treatment processes as readily as fatty acids, carbohydrates, or proteins.

Biochemical oxidation of many of the toxic organic pollutants has been investigated, at least in laboratory-scale studies, at concentrations higher than commonly expected in municipal wastewater. General observations relating molecular structure to ease of degradation have been developed for all of these pollutants. The conclusion reached by study of the limited data is that biological treatment produces a moderate degree of degradation of 1,1,1-trichloroethane. No evidence is available for drawing conclusions about its possible toxic or inhibitory effect on POTW operation. However, for degradation to occur, a fairly constant

input of the compound would be necessary.

Its water solubility would allow 1,1,1-trichloroethane, present in the influent and not biodegradable, to pass through a POTW into the effluent. One factor which has received some attention, but no detailed study, is the volatilization of the lower molecular weight organics from a POTW. If 1,1,1-trichloroethane is not biodegraded, it will volatilize during aeration processes in the POTW.

Hexachloroethane (12). Hexachloroethane (CCl_3CCl_3), also called perchloroethane is a white crystalline solid with a camphor-like odor. It is manufactured from tetrachloroethylene, and is a minor product in many industrial chlorination processes designed to produce lower chlorinated hydrocarbons. Hexachloroethane sublimates at 185°C and has a vapor pressure of about 0.2 mm Hg at 20°C . It is insoluble in water (50 mg/l at 22°C) and soluble in some organic solvents

Hexachloroethane can be used in lubricants designed to withstand extreme pressure. It is used as a plasticizer for cellulose esters, and as a pesticide. It is also used as a retarding agent in fermentation, as an accelerator in the rubber industry, and in pyrotechnic and smoke devices.

Hexachloroethane is considered to be toxic to humans by ingestion and inhalation. In laboratory animals liver and kidney damage have been observed. Symptoms in humans exposed to hexachloroethane vapor include severe eye irritation and vision impairment. Based on studies on laboratory animals, hexachloroethane is considered to be carcinogenic.

For the maximum protection to human health from the potential carcinogenic effects of exposure to hexachloroethane through ingestion of water and contaminated aquatic organisms, the ambient water concentration is zero. Concentrations of hexachloroethane estimated to result in additional lifetime cancer risks at levels of 10^{-7} , 10^{-6} , and 10^{-5} are 0.000059 mg/l, 0.00059 mg/l, and 0.0059 mg/l, respectively.

Data on the behavior of hexachloroethane in POTW are not available. Many of the organic priority pollutants have been investigated at least in laboratory scale studies, at concentrations higher than those expected to be contained by most municipal wastewaters. General observations have been developed relating molecular structure to ease of degradation for all of the organic priority pollutants. The conclusion reached by study of the limited data is that biological treatment produces little or no removal of hexachloroethane in POTW. The lack of water solubility and the expected affinity of hexachloroethane for solid particles lead to the expectation that this compound will be removed to the sludge in POTW. No information was found regarding possible uptake of hexachloroethane by plants grown on soils amended with hexachloroethane-bearing sludge.

1,1-Dichloroethane (13). 1,1-Dichloroethane, $C_2H_4Cl_2$, also called ethylidene dichloride and ethylidene chlorrde, is a colorless liquid manufactured by reacting hydrogen chloride with vinyl chloride in 1,1-dichloroethane solution in the presence of a catalyst. However, it is reportedly not manufactured commercially in the U.S. 1,1-Dichloroethane boils at $57^{\circ}C$ and has a vapor pressure of 182 mm Hg at $20^{\circ}C$. It is slightly soluble in water (5.5 g/l at $20^{\circ}C$) and very soluble in organic solvents.

1,1-Dichloroethane is used as an extractant for heat-sensitive substances and as a solvent for rubber and silicone grease.

1,1-Dichloroethane is less toxic than its isomer (1,2-dichloroethane), but its use as an anaesthetic has been discontinued because of marked excitation of the heart. It causes central nervous system depression in humans. There are insufficient data to derive water quality criteria for 1,1-dichloroethane.

Data on the behavior of 1,1-dichloroethane in a POTW are not available. Many of the toxic organic pollutants have been investigated, at least in laboratory-scale studies, at concentrations higher than those expected to be contained by most municipal wastewaters. General observations have been developed relating molecular structure to ease of degradation for all of the toxic organic pollutants. The conclusion reached by study of the limited data is that biological treatment produces only a moderate removal of 1,1-dichloroethane in a POTW by degradation.

The high vapor pressure of 1,1-dichloroethane is expected to result in volatilization of some of the compound from aerobic processes in a POTW. Its water solubility will result in some of the 1,1-dichloroethane which enters the POTW leaving in the effluent from the POTW.

1,1,2-Trichloroethane (14). 1,1,2-Trichloroethane is one of the two possible trichloroethanes and is sometimes called ethane trichloride or vinyl trichloride. It is used as a solvent for fats, oils, waxes, and resins, in the manufacture of 1,1-dichloroethylene, and as an intermediate in organic synthesis.

1,1,2-Trichloroethane is a clear, colorless liquid at room temperature with a vapor pressure of 16.7 mm Hg at $20^{\circ}C$, and a boiling point of $113^{\circ}C$. It is insoluble in water and very soluble in organic solvents. The formula is $CHCl_2CH_2Cl$.

Human toxicity data for 1,1,2-trichloroethane do not appear in the literature. The compound does produce liver and kidney damage in laboratory animals after intraperitoneal administration. No literature data were found concerning teratogenicity or mutagenicity of 1,1,2-trichloroethane. However, mice treated with 1,1,2-trichloroethane showed increased incidence of hepatocellular carcinoma. Although bioconcentration factors are not available for 1,1,2-trichloroethane in fish and other freshwater aquatic organisms, it is concluded on the basis of octanol-water

partition coefficients that bioconcentration does occur.

For the maximum protection of human health from the potential carcinogenic effects of exposure to 1,1,2-trichloroethane through ingestion of water and contaminated aquatic organisms, the ambient water concentration is zero. Concentrations of this compound estimated to result in additional lifetime cancer risks at risk levels of 10^{-7} , 10^{-6} , and 10^{-5} are 0.00006 mg/l, 0.0006 mg/l, and 0.006 mg/l, respectively. If contaminated aquatic organisms alone are consumed, excluding the consumption of water, the water concentration should be less than 0.418 mg/l to keep the increased lifetime cancer risk below 10^{-5} . Available data show that adverse effects on aquatic life occur at concentrations higher than those cited for human health risks.

No detailed study of 1,1,2-trichloroethane behavior in a POTW is available. However, it is reported that small amounts are formed by chlorination processes and that this compound persists in the environment (greater than two years) and it is not biologically degraded. This information is not completely consistent with the conclusions based on laboratory-scale biochemical oxidation studies and relating molecular structure to ease degradation. That study concluded that biological treatment in a POTW will produce moderate removal of 1,1,2-trichloroethane.

The lack of water solubility and the relatively high vapor pressure may lead to removal of this compound from a POTW by volatilization.

2,4,6-Trichlorophenol (21). 2,4,6-Trichlorophenol ($6H_2Cl_3OH$, abbreviated here to 2,4,6-TCP) is a colorless, crystalline solid at room temperature. It is prepared by the direct chlorination of phenol. 2,4,6-TCP melts at $68^{\circ}C$ and is slightly soluble in water (0.8 gm/l at $25^{\circ}C$). This phenol does not produce a color with 4-aminoantipyrene, and therefore does not contribute to the nonconventional pollutant parameter "Total Phenols." No data were found on production volumes.

2,4,6-TCP is used as a fungicide, bactericide, glue and wood preservative, and for antimildew treatment. It is also used for the manufacture of 2,3,4,6-tetrachlorophenol and pentachlorophenol.

No data were found on human toxicity effects of 2,4,6-TCP. Reports of studies with laboratory animals indicate that 2,4,6-TCP produced convulsions when injected interperitoneally. Body temperature was elevated also. The compound also produced inhibition of ATP production in isolated rat liver mitochondria, increased mutation rates in one strain of bacteria, and produced a genetic change in rats. No studies on teratogenicity were found. Results of a test for carcinogenicity were inconclusive.

For the prevention of adverse effects due to the organoleptic properties of 2,4,6-trichlorophenol in water, the water quality criterion is 0.100 mg/l.

Although no data were found regarding the behavior of 2,4,6-TCP in a POTW, studies of the biochemical oxidation of the compound have been made at laboratory scale at concentrations higher than those normally expected in municipal wastewaters. Biochemical oxidation to 2,4,6-TCP at 100 mg/l produced 23 percent degradation using a phenol-adapted acclimated seed culture. Based on these results, biological treatment in a POTW is expected to produce a moderate degree of degradation. Another study indicates that 2,4,6-TCP may be produced in a POTW by chlorination of phenol during normal chlorination treatment.

Para-chloro-meta-cresol (22). Para-chloro-meta-cresol (C_7H_6OH) is thought to be a 4-chloro-3-methyl-phenol (4-chloro-meta-cresol, or 2-chloro-5-hydroxy-toluene), but is also used by some authorities to refer to 6-chloro-3-methyl-phenol (6-chloro-meta-cresol, or 4-chloro-3-hydroxy-toluene), depending on whether the chlorine is considered to be para to the methyl or to the hydroxy group. It is assumed for the purposes of this document that the subject compound is 2-chloro-5-hydroxy-toluene. This compound is a colorless crystalline solid melting at 66 to 68°C. It is slightly soluble in water (3.8 gm/l) and soluble in organic solvents. This phenol reacts with p-aminoantipyrene to give a colored product and therefore contributes to the nonconventional pollutant parameter designated "Total Phenols." No information on manufacturing methods or volumes produced was found.

Para-chloro-meta cresol (abbreviated here as PCMC) is marketed as a microbiocide, and was proposed as an antiseptic and disinfectant more than 40 years ago. It is used in glues, gums, paints, inks, textiles, and leather goods. PCMC was found in raw wastewaters from the die casting quench operation from one subcategory of foundry operations.

Although no human toxicity data are available for PCMC, studies on laboratory animals have demonstrated that this compound is toxic when administered subcutaneously and intravenously. Death was preceded by severe muscle tremors. At high dosages, kidney damage occurred. On the other hand, an unspecified isomer of chlorocresol, presumed to be PCMC, is used at a concentration of 0.15 percent to preserve mucous heparin, a natural product administered intravenously as an anticoagulant. The report does not indicate the total amount of PCMC typically received. No information was found regarding possible teratogenicity, or carcinogenicity of PCMC.

Two reports indicate that PCMC undergoes degradation in biochemical oxidation treatments carried out at concentrations higher than are expected to be encountered in POTW influents. One study showed 50 percent degradation in 3.5 hours when a phenol-adapted acclimated seed culture was used with a solution of 60 mg/l PCMC. The other study showed 100 percent degradation of a 20 mg/l solution of PCMC in two weeks in an aerobic activated sludge test system. No degradation of PCMC occurred

under anaerobic conditions.

Chloroform (23). Chloroform, CHCl_3 , also called trichloromethane, is a colorless liquid manufactured commercially by chlorination of methane. Careful control of conditions maximizes chloroform production, but other products must be separated. Chloroform boils at 61°C and has a vapor pressure of 200 mm Hg at 25°C . It is slightly soluble in water (8.22 g/l at 20°C) and readily soluble in organic solvents.

Chloroform is used as a solvent and to manufacture refrigerants, pharmaceuticals, plastics, and anesthetics. It is seldom used as an anesthetic.

Toxic effects of chloroform on humans include central nervous system depression, gastrointestinal irritation, liver and kidney damage, and possible cardiac sensitization to adrenalin. Carcinogenicity has been demonstrated for chloroform on laboratory animals.

For the maximum protection of human health from the potential carcinogenic effects of exposure to chloroform through ingestion of water and contaminated aquatic organisms, the ambient water concentration is zero. Concentrations of chloroform estimated to result in additional lifetime cancer risks at the levels of 10^{-7} , 10^{-6} , and 10^{-5} were 0.000021 mg/l, 0.00021 mg/l, and 0.0021 mg/l, respectively.

No data are available regarding the behavior of chloroform in a POTW. However, the biochemical oxidation of this compound was studied in one laboratory-scale study at concentrations higher than those expected to be contained by most municipal wastewaters. After 5, 10, and 20 days no degradation of chloroform was observed. The conclusion reached is that biological treatment produces little or no removal by degradation of chloroform in a POTW.

The high vapor pressure of chloroform is expected to result in volatilization of the compound from aerobic treatment steps in a POTW. Remaining chloroform is expected to pass through into the POTW effluent.

2-Chlorophenol (24). 2-Chlorophenol ($\text{ClC}_6\text{H}_4\text{OH}$), also called ortho-chlorophenol, is a colorless liquid at room temperature, manufactured by direct chlorination of phenol followed by distillation to separate it from the other principal product, 4-chlorophenol. 2-Chlorophenol solidifies below 7°C and boils at 176°C . It is soluble in water (28.5 gm/l at 20°C) and soluble in several types of organic solvents. This phenol gives a strong color with 4-aminoantipyrene and therefore contributes to the nonconventional pollutant parameter "Total Phenols." Production statistics could not be found. 2-Chlorophenol is used almost exclusively as a chemical intermediate in the production of pesticides and dyes. Production of some phenolic resins uses 2-chlorophenol.

Very few data are available on which to determine the toxic effects of 2-chlorophenol on humans. The compound is more toxic to laboratory mammals when administered orally than when administered subcutaneously or intravenously. This effect is attributed to the fact that the compound is almost completely in the unionized state at the low pH of the stomach and hence is more readily absorbed into the body. Initial symptoms are restlessness and increased respiration rate, followed by motor weakness and convulsions induced by noise or touch. Coma follows. Following lethal doses, kidney, liver, and intestinal damage were observed. No studies were found which addressed the teratogenicity or mutagenicity of 2-chlorophenol. Studies of 2-chlorophenol as a promoter of carcinogenic activity of other carcinogens were conducted by dermal application. Results do not bear a determinable relationship to results of oral administration studies.

For the prevention of adverse effects due to the organoleptic properties of 2-chlorophenol in water, the criterion is 0.0003 mg/l.

Data on the behavior of 2-chlorophenol in a POTW are not available. However, laboratory-scale studies have been conducted at concentrations higher than those expected to be found in municipal wastewaters. At 1 mg/l of 2-chlorophenol, an acclimated culture produced 100 percent degradation by biochemical oxidation after 15 days. Another study showed 45, 70, and 79 percent degradation by biochemical oxidation after 5, 10, and 20 days, respectively. The conclusion reached by the study of these limited data, and general observations on all toxic organic pollutants relating molecular structure to ease of biochemical oxidation, is that 2-chlorophenol is removed to a high degree or completely by biological treatment in a POTW. Undegraded 2-chlorophenol is expected to pass through a POTW into the effluent because of the water solubility. Some 2-chlorophenol is also expected to be generated by chlorination treatments of POTW effluents containing phenol.

1,1-Dichloroethylene (29). 1,1-Dichloroethylene (1,1-DCE), also called vinylidene chloride, is a clear colorless liquid manufactured by dehydrochlorination of 1,1,2-trichloroethane. 1,1-DCE has the formula CCl_2CH_2 . It has a boiling point of 32°C , and a vapor pressure of 591 mm Hg at 25°C . 1,1-DCE is slightly soluble in water (2.5 mg/l) and is soluble in many organic solvents. U.S. production is in the range of hundreds of thousands of tons annually.

1,1-DCE is used as a chemical intermediate and for copolymer coatings or films. It may enter the wastewater of an industrial facility as the result of decomposition of 1,1,1-trichloroethylene used in degreasing operations, or by migration from vinylidene chloride copolymers exposed to the process water. Human toxicity of 1,1-DCE has not been demonstrated; however, it is a suspected human carcinogen. Mammalian toxicity studies have

focused on the liver and kidney damage produced by 1,1-DCE. Various changes occur in those organs in rats and mice ingesting 1,1-DCE.

For the maximum protection of human health from the potential carcinogenic effects of exposure to 1,1-dichloroethylene through ingestion of water and contaminated aquatic organisms, the ambient water concentration is zero. The concentration of 1,1-DCE estimated to result in an additional lifetime cancer risk of 1 in 100,000 is 0.0013 mg/l.

Under laboratory conditions, dichloroethylenes have been shown to be toxic to fish. The primary effect of acute toxicity of the dichloroethylenes is depression of the central nervous system. The octanol-water partition coefficient of 1,1-DCE indicates it should not accumulate significantly in animals.

The behavior of 1,1-DCE in a POTW has not been studied. However, its very high vapor pressure is expected to result in release of significant percentages of this material to the atmosphere in any treatment involving aeration. Degradation of dichloroethylene in air is reported to occur, with a half-life of eight weeks.

Biochemical oxidation of many of the toxic organic pollutants has been investigated in laboratory-scale studies at concentrations higher than would normally be expected in municipal wastewaters. General observations relating molecular structure to ease of degradation have been developed for all of these pollutants. The conclusion reached by study to the limited data is that biological treatment produces little or no degradation of 1,1-dichloroethylene. No evidence is available for drawing conclusions about the possible toxic or inhibitory effect of 1,1-DCE on POTW operation. Because of water solubility, 1,1-DCE which is not volatilized or degraded is expected to pass through a POTW. Very little 1,1-DCE is expected to be found in sludge from a POTW.

1,2-trans-Dichloroethylene (30). 1,2-Dichloroethylene (1,2-trans-DCE) is a clear, colorless liquid with the formula CHClCHCl . 1,2-trans-DCE is produced in mixture with the cis-isomer by chlorination of acetylene. The cis-isomer has distinctly different physical properties. Industrially, the mixture is used rather than the separate isomers. 1,2-trans-DCE has a boiling point of 48°C , and a vapor pressure of 234 mm Hg at 25°C .

The principal use of 1,2-dichloroethylene (mixed isomers) is to produce vinyl chloride. It is used as a lead scavenger in gasoline, general solvent, and for synthesis of various other organic chemicals. When it is used as a solvent, 1,2-trans-DCE can enter wastewater streams.

Although 1,2-trans-DCE is thought to produce fatty degeneration of mammalian liver, there are insufficient data on which to base any ambient water criterion.

In the reported toxicity test of 1,2-trans-DCE on aquatic life, the compound appeared to be about half as toxic as the other dichloroethylene (1,1-DCE) on the toxic pollutants list.

The behavior of 1,2-trans-DCE in a POTW has not been studied. However, its high vapor pressure is expected to result in release of a significant percentage of this compound to the atmosphere in any treatment involving aeration. Degradation of the dichloroethylenes in air is reported to occur, with a half-life of eight weeks.

Biochemical oxidation of many of the toxic organic pollutants has been investigated in laboratory-scale studies at concentrations higher than would normally be expected in municipal wastewaters. General observations relating molecular structure to ease of degradation have been developed for all of these pollutants. The conclusion reached by the study of the limited data is that biochemical oxidation produces little or no degradation of 1,2-trans-dichloroethylene. No evidence is available for drawing conclusions about the possible toxic or inhibitory effect of 1,2-trans-dichloroethylene on POTW operation. It is expected that its low molecular weight and degree of water solubility will result in 1,2-trans-DCE passing through a POTW to the effluent if it is not degraded or volatilized. Very little 1,2-trans-DCE is expected to be found in sludge from a POTW.

2,4-Dichlorophenol (31). 2,4-Dichlorophenol, a white, low melting solid, melts at 45°C. It is soluble in alcohol and carbon tetrachloride and slightly soluble in water. This compound is moderately toxic by ingestion and is a strong irritant to tissue.

2,4-Dimethylphenol (34). 2,4-Dimethylphenol (2,4-DMP), also called 2,4-xyleneol, is a colorless, crystalline solid at room temperature (25°C), but melts at 27°C to 28°C. 2,4-DMP is slightly soluble in water and, as a weak acid, is soluble in alkaline solutions. Its vapor pressure is less than 1 mm Hg at room temperature.

2,4-DMP (C₈H₁₀O) is a natural product, occurring in coal and petroleum sources. It is used commercially as an intermediate for manufacture of pesticides, dye stuffs, plastics and resins, and surfactants. It is found in the water runoff from asphalt surfaces. It can find its way into the wastewater of a manufacturing plant from any of several adventitious sources.

Analytical procedures specific to this compound are used for its identification and quantification in wastewaters. This compound does not contribute to "Total Phenols" determined by the 4-aminoantipyrine method.

Three methylphenol isomers (cresols) and six dimethylphenol isomers (xyleneols) generally occur together in natural products, industrial processes, commercial products, and phenolic wastes. Therefore, data are not available for human exposure to 2,4-DMP

alone. In addition to this, most mammalian tests for toxicity of individual dimethylphenol isomers have been conducted with isomers other than 2,4-DMP.

In general, the mixtures of phenol, methylphenols, and dimethylphenols contain compounds which produced acute poisoning in laboratory animals. Symptoms were difficult breathing, rapid muscular spasms, disturbance of motor coordination, and asymmetrical body position. In a 1977 National Academy of Science publication the conclusion was reached that, "In view of the relative paucity of data on the mutagenicity, carcinogenicity, teratogenicity, and long term oral toxicity of 2,4-dimethylphenol, estimates of the effects of chronic oral exposure at low levels cannot be made with any confidence." No ambient water quality criterion can be set at this time. In order to protect public health, exposure to this compound should be minimized as soon as possible.

Toxicity data for fish and freshwater aquatic life are limited; however, in reported studies of 2,4-dimethylphenol at concentrations as high as 2 mg/l no adverse effects were observed.

The behavior of 2,4-DMP in a POTW has not been studied. As a weak acid, its behavior may be somewhat dependent on the pH of the influent to the POTW. However, over the normal limited range to POTW pH, little effect of pH would be expected.

Biological degradability of 2,4-DMP as determined in one study, showed 94.5 percent removal based on chemical oxygen demand (COD). Thus, substantial removal is expected for this compound. Another study determined that persistence of 2,4-DMP in the environment is low, and thus any of the compound which remained in the sludge or passed through the POTW into the effluent would be degraded within moderate length of time (estimated as two months in the report).

2,4-Dinitrotoluene (35) 2,4-Dinitrotoluene ((N02)2C6H3CH3), a yellow crystalline compound, is manufactured as a co-product with the 2,6-isomer by nitration of nitrotoluene. It melts at 71°C. 2,4-Dinitrotoluene is insoluble in water (0.27 g/l at 22°C) and soluble in a number of organic solvents. Production data for the 2,4-isomer alone are not available. The 2,4- and 2,6-isomers are manufactured in an 80:20 or 65:35 ratio, depending on the process used. Annual U.S. commercial production is about 150 thousand tons of the two isomers. Unspecified amounts are Produced by the U.S. government and further nitrated to trinitrotoluene (TNT) for military use. The major use of the dinitrotoluene mixture is for production of toluene diisocyanate used to make polyurethanes. Another use is in production of dyestuffs.

The toxic effect of 2,4-dinitrotoluene in humans is primarily methemoglobinemia (a blood condition hindering oxygen transport by the blood). Symptoms depend on severity of the disease. but include cyanosis, dizziness, pain in joints, headache, and loss of appetite in workers inhaling the compound. Laboratory animals

fed oral doses of 2,4-dinitrotoluene exhibited many of the same symptoms. Aside from the effects in red blood cells, effects are observed in the nervous system and testes.

Chronic exposure to 2,4-dinitrotoluene may produce liver damage and reversible anemia. No data were found on teratogenicity of this compound. Mutagenic data are limited and are regarded as confusing. Data resulting from studies of carcinogenicity of 2,4-dinitrotoluene point to a need for further testing for this property.

For the maximum protection of human health from the potential carcinogenic effects of exposure to 2,4-dinitrotoluene through ingestion of water and contaminated aquatic organisms, the ambient water concentration is zero. Concentrations of 2,4-dinitrotoluene estimated to result in additional lifetime cancer risk at risk levels of 10^{-7} , 10^{-6} and 10^{-5} are 0.00074 mg/l, 0.074 mg/l, and 0.740 mg/l, respectively.

Data on the behavior of 2,4-dinitrotoluene in a POTW are not available. However, biochemical oxidation of 2,4-dinitrophenol was investigated on a laboratory scale. At 100 mg/l of 2,4-dinitrotoluene, a concentration considerably higher than expected in municipal wastewaters, biochemical oxidation by an acclimated, phenol-adapted seed culture produced 52 percent degradation in three hours. Based on this limited information and general observations relating molecular structure to ease of degradation for all the toxic organic pollutants, it was concluded that biological treatment in a POTW removes 2,4-dinitrotoluene to a high degree or completely. No information is available regarding possible interference by 2,4-dinitrotoluene in POTW treatment processes, or on the possible detrimental effect on sludge used to amend soils in which food crops are grown.

Ethylbenzene (38). Ethylbenzene (C_8H_{10}) is a colorless, flammable liquid manufactured commercially from benzene and ethylene. Approximately half of the benzene used in the U.S. goes into the manufacture of more than three million tons of ethylbenzene annually. Ethylbenzene boils at $136^{\circ}C$ and has a vapor pressure of 7 mm Hg at $20^{\circ}C$. It is slightly soluble in water (0.14 g/l at $15^{\circ}C$) and is very soluble in organic solvents.

About 98 percent of the ethylbenzene produced in the U.S. goes into the production of styrene, much of which is used in the plastics and synthetic rubber industries. Ethylbenzene is a constituent of xylene mixtures used as diluents in the paint industry, agricultural insecticide sprays, and gasoline blends.

Although humans are exposed to ethylbenzene from a variety of sources in the environment, little information on effects of ethylbenzene in man or animals is available. Inhalation can irritate eyes, affect the respiratory tract, or cause vertigo. In laboratory animals, ethylbenzene exhibited low toxicity. There are no data available on teratogenicity, mutagenicity, or carcinogenicity of ethylbenzene.

Criteria are based on data derived from inhalation exposure limits. For the protection of human health from the toxic properties of ethylbenzene ingested through water and contaminated aquatic organisms, the ambient water quality criterion is 1.1 mg/l.

The behavior of ethylbenzene in a POTW has not been studied in detail. Laboratory-scale studies of the biochemical oxidation of ethylbenzene at concentrations greater than would normally be found in municipal wastewaters have demonstrated varying degrees of degradation. In one study with phenol-acclimated seed cultures, 27 percent degradation was observed in a half day at 250 mg/l ethylbenzene. Another study at unspecified conditions showed 32, 38, and 45 percent degradation after 5, 10, and 20 days, respectively. Based on these results and general observations relating molecular structure of degradation, it is concluded that biological treatment produces only moderate removal of ethylbenzene in a POTW by degradation.

Other studies suggest that most of the ethylbenzene entering a POTW is removed from the aqueous stream to the sludge. The ethylbenzene contained in the sludge removed from the POTW may volatilize.

Fluoranthene (39). Fluoranthene (1,2-benzacenaphthene) is one of the compounds called polynuclear aromatic hydrocarbons (PAH). A pale yellow solid at room temperature, it melts at 111°C and has a negligible vapor pressure at 25°C. Water solubility is low (0.2 mg/l). Its molecular formula is C₁₆H₁₀. Fluoranthene, along with many other PAHs, is found throughout the environment. It is produced by pyrolytic processing of organic raw materials, such as coal and petroleum, at high temperature (coking processes). It occurs naturally as a product of plant biosynthesis. Cigarette smoke contains fluoranthene. Although it is not used as the pure compound in industry, it has been found at relatively higher concentrations (0.002 mg/l) than most other PAH's in at least one industrial effluent. Furthermore, in a 1977 EPA survey to determine levels of PAH in U.S. drinking water supplies, none of the 110 samples analyzed showed any PAH other than fluoranthene.

Experiments with laboratory animals indicate that fluoranthene presents a relatively low degree of toxic potential from acute exposure, including oral administration. Where death occurred, no information was reported concerning target organs or specific cause of death.

There is no epidemiological evidence to prove that PAH in general, and fluoranthene, in particular, present in drinking water are related to the development of cancer. The only studies directed toward determining carcinogenicity of fluoranthene have been skin tests on laboratory animals. Results of these tests show that fluoranthene has no activity as a complete carcinogen (i.e., an agent which produces cancer when applied by itself),

but exhibits significant cocarcinogenicity (i.e., in combination with a carcinogen, it increases the carcinogenic activity).

Based on the limited animal study data, and following an established procedure, the ambient water quality criterion for fluoranthene alone (not in combination with other PAH) is determined to be 200 mg/l for the protection of human health from its toxic properties.

There are no data on the chronic effects of fluoranthene on freshwater organisms. One saltwater invertebrate shows chronic toxicity at concentrations below 0.016 mg/l. For some freshwater fish species the concentrations producing acute toxicity are substantially higher, but data are very limited.

Results of studies of the behavior of fluoranthene in conventional sewage treatment processes found in a POTW have been published. Removal of fluoranthene during primary sedimentation was found to be 62 to 66 percent (from an initial value of 0.00323 to 0.04435 mg/l to a final value of 0.00122 to 0.0146 mg/l), and the removal was 91 to 99 percent (final values of 0.00028 to 0.00026 mg/l) after biological purification with activated sludge processes.

A review was made of data on biochemical oxidation of many of the toxic organic pollutants investigated in laboratory-scale studies at concentrations higher than would normally be expected in municipal wastewaters. General observations relating molecular structure to ease of degradation have been developed for all of these pollutants. The conclusion reached by study of the limited data is that biological treatment produces little or no degradation of fluoranthene. The same study, however, concludes that fluoranthene would be readily removed by filtration and oil-water separation and other methods which rely on water insolubility, or adsorption on other particulate surfaces. This latter conclusion is supported by the previously cited study showing significant removal by primary sedimentation.

No studies were found to give data on either the possible interference of fluoranthene with POTW operation, or the persistence of fluoranthene in sludges or POTW effluent waters. Several studies have documented the ubiquity of fluoranthene in the environment and it cannot be readily determined if this results from persistence of anthropogenic fluoranthene or the replacement of degraded fluoranthene by natural processes such as biosynthesis in plants.

Methylene Chloride (44). Methylene chloride, also called dichloromethane (CH_2Cl_2), is a colorless liquid manufactured by chlorination of methane or methyl chloride followed by separation from the higher chlorinated methanes formed as co-products. Methylene chloride boils at 40°C , and has a vapor pressure of 362 mm Hg at 20°C . It is slightly soluble in water (20 g/l at 20°C), and very soluble in organic solvents. U.S. annual production is about 250,000 tons.

Methylene chloride is a common industrial solvent found in insecticides, metal cleaners, paint, and paint and varnish removers.

Methylene chloride is not generally regarded as highly toxic to humans. Most human toxicity data are for exposure by inhalation. Inhaled methylene chloride acts as a central nervous system depressant. There is also evidence that the compound causes heart failure when large amounts are inhaled.

Methylene chloride does produce mutation in tests for this effect. In addition, a bioassay recognized for its extremely high sensitivity to strong and weak carcinogens produced results which were marginally significant. Thus potential carcinogenic effects of methylene chloride are not confirmed or denied, but are under continuous study. Difficulty in conducting and interpreting the test results at the low boiling point (40°C) of methylene chloride increases the difficulty of maintaining the compound in growth media during incubation at 37°C; and the difficulty of removing all impurities, some of which might themselves be carcinogenic.

For the protection of human health from the toxic properties of methylene chloride ingested through water and contaminated aquatic organisms, the ambient water criterion is 0.002 mg/l. The behavior of methylene chloride in a POTW has not been studied in any detail. However, the biochemical oxidation of this compound was studied in one laboratory-scale study at concentrations higher than those expected to be contained by most municipal wastewaters. After five days no degradation of methylene chloride was observed. The conclusion reached is that biological treatment produces little or no removal by degradation of methylene chloride in a POTW.

The high vapor pressure of methylene chloride is expected to result in volatilization of the compound from aerobic treatment steps in a POTW. It has been reported that methylene chloride inhibits anaerobic processes in a POTW. Methylene chloride that is not volatilized in the POTW is expected to pass through into the effluent.

Dichlorobromomethane (48). This compound is a halogenated aliphatic. Research has shown that halomethanes have carcinogenic properties, and exposure to this compound may have adverse effects on human health.

Chlorodibromomethane (51). This compound is a halogenated aliphatic. Research has shown that halomethanes have carcinogenic properties, and exposure to this compound may have adverse effects on human health.

Isophorone (54). Isophorone is an industrial chemical produced at a level of tens of millions of pounds annually in the U.S. The chemical name for isophorone is 3,5,5-trimethyl-2-cyclohexen-1-

one and it is also known as trimethyl cyclohexanone and isoacetophorone. The formula is $C_6H_5(CH_3)_3O$. Normally, it is produced as the gamma isomer; technical grades contain about 3 percent of the beta isomer (3,5,5-trimethyl-3-cyclohexen-1-one). The pure gamma isomer is a water-white liquid, with vapor pressure less than 1 mm Hg at room temperature, and a boiling point of 215.2°C. It has a camphor- or peppermint-like odor and yellows upon standing. It is slightly soluble (12 mg/l) in water and dissolves in fats and oils.

Isophorone is synthesized from acetone and is used commercially as a solvent or cosolvent for finishes, lacquers, polyvinyl and nitrocellulose resins, pesticides, herbicides, fats, oils, and gums. It is also used as a chemical feedstock.

Because isophorone is an industrially used solvent, most toxicity data are for inhalation exposure. Oral administration to laboratory animals in two different studies revealed no acute or chronic effects during 90 days and no hematological or pathological abnormalities were reported. Apparently, no studies have been completed on the carcinogenicity of isophorone.

Isophorone does undergo bioconcentration in the lipids of aquatic organisms and fish.

Based on subacute data, the ambient water quality criterion for isophorone ingested through consumption of water and fish is set at 460 mg/l for the protection of human health from its toxic properties

Studies of the effects of isophorone on fish and aquatic organisms reveal relatively low toxicity compared to some other toxic pollutants.

The behavior of isophorone in a POTW has not been studied. However, the biochemical oxidation of many of the toxic organic pollutants has been investigated in laboratory scale studies at concentrations higher than would normally be expected in municipal wastewaters. General observations relating molecular structure to ease of degradation have been developed for all of these pollutants. The conclusion reached by the study of the limited data is that biochemical treatment in a POTW produces moderate removal of isophorone. This conclusion is consistent with the findings of an experimental study of microbiological degradation of isophorone which showed about 45 percent oxidation in 15 to 20 days in domestic wastewater, but only 9 percent in salt water. No data were found on the persistence of isophorone in sewage sludge.

Naphthalene (55). Naphthalene is an aromatic hydrocarbon with two orthocondensed benzene rings and a molecular formula of $C_{10}H_8$. As such, it is properly classed as a polynuclear aromatic hydrocarbon (PAH). Pure naphthalene is a white crystalline solid melting at 80°C. For a solid, it has a relatively high vapor pressure (0.05 mm Hg at 20°C), and moderate water solubility (19

mg/l at 20°C). Naphthalene is the most abundant single component of coal tar. Production is more than a third of a million tons annually in the U.S. About three fourths of the production is used as feedstock for phthalic anhydride manufacture. Most of the remaining production goes into manufacture of insecticide, dyestuffs, pigments, and pharmaceuticals. Chlorinated and partially hydrogenated naphthalenes are used in some solvent mixtures. Naphthalene is also used as a moth repellent.

Naphthalene, ingested by humans, has reportedly caused vision loss (cataracts), hemolytic anemia and occasionally renal disease. These effects of naphthalene ingestion are confirmed by studies on laboratory animals. No carcinogenicity studies are available which can be used to demonstrate carcinogenic activity for naphthalene. Naphthalene does bioconcentrate in aquatic organisms.

For the protection of human health from the toxic properties of naphthalene ingested through water and through contaminated aquatic organisms, the ambient water criterion is determined to be 143 mg/l.

Only a limited number of studies have been conducted to determine the effects of naphthalene on aquatic organisms. The data from those studies show only moderate toxicity.

Naphthalene has been detected in sewage plant effluents at concentrations up to 0.022 mg/l in studies carried out by the U.S. EPA. Influent levels were not reported. The behavior of naphthalene in a POTW has not been studied. However, recent studies have determined that naphthalene will accumulate in sediments at 100 times the concentration in overlying water. These results suggest that naphthalene will be readily removed by primary and secondary settling in a POTW, if it is not biologically degraded.

Biochemical oxidation of many of the toxic organic pollutants has been investigated in laboratory-scale studies at concentrations higher than would normally be expected in municipal wastewaters. General observations relating molecular structure to ease to degradation have been developed for all of these pollutants. The conclusion reached by study of the limited data is that biological treatment produces a high removal by degradation of naphthalene. One recent study has shown that microorganisms can degrade naphthalene, first to a dihydro compound, and ultimately to carbon dioxide and water.

Nitrobenzene (56). Nitrobenzene (C₆H₅N₀₂), also called nitrobenzol and oil of mirbane, is a pale yellow, oily liquid, manufactured by reacting benzene with nitric acid and sulfuric acid. Nitrobenzene boils at 210°C and has a vapor pressure of 0.3g mm Hg at 25°C. It is slightly soluble in water (1.9 g/l at 20°C) and is miscible with most organic solvents. Estimates of annual U.S. production vary widely, ranging from 100 to 350 thousand tons.

Almost the entire volume of nitrobenzene produced (97 percent) is converted to aniline, which is used in dyes, rubber, and medicinals. Other uses for nitrobenzene include: solvent for organic synthesis, metal polishes, shoe polish, and perfume.

The toxic effects of ingested or inhaled nitrobenzene in humans are related to its action in blood: methemoglobinemia and cyanosis. Nitrobenzene administered orally to laboratory animals caused degeneration of heart, kidney and liver tissue; paralysis, and death. Nitrobenzene has also exhibited teratogenicity in laboratory animals but studies conducted to determine mutagenicity or carcinogenicity did not reveal either of these properties.

For the prevention of adverse effects due to the organoleptic properties of nitrobenzene in water, the criterion is 0.030 mg/l.

Data on the behavior of nitrobenzene in POTW are not available. However, laboratory-scale studies have been conducted at concentrations higher than those expected to be found in municipal wastewaters. Biochemical oxidation produced no degradation after 5, 10, and 20 days. A second study also reported no degradation after 28 hours, using an acclimated, phenol-adapted seed culture with nitrobenzene at 100 mg/l. Based on these limited data, and on general observations relating molecular structure to ease of biological oxidation, it is concluded that little or no removal of nitrobenzene occurs during biological treatment in POTW. The low water solubility and low vapor pressure of nitrobenzene lead to the expectation that nitrobenzene will be removed from POTW in the effluent and by volatilization during aerobic treatment.

2-Nitrophenol (57). 2-Nitrophenol ($\text{NO}_2\text{C}_6\text{H}_4\text{OH}$), also called orthonitrophenol, is a light yellow crystalline solid, manufactured commercially by hydrolysis of 2-chloro-nitrobenzene with aqueous sodium hydroxide. 2-Nitrophenol melts at 45°C and has a vapor pressure of 1 mm Hg at 49°C . 2-Nitrophenol is slightly soluble in water (2.1 g/l at 20°C) and soluble in organic solvents. This phenol does not react to give a color with 4-amino-antipyrene, and therefore does not contribute to the nonconventional pollutant parameter "Total Phenols." U.S. annual production is 5,000 to 8,000 tons.

The principle use of ortho-nitrophenol is to synthesize ortho-aminophenol, ortho-nitroanisole, and other dyestuff intermediates.

The toxic effects of 2-nitrophenol on humans have not been extensively studied. Data from experiments with laboratory animals indicate that exposure to this compound causes kidney and liver damage. Other studies indicate that the compound acts directly on cell membranes, and inhibits certain enzyme systems in vitro.

No information regarding potential teratogenicity was found. Available data indicate that this compound does not pose a mutagenic hazard to humans. Very limited data for 2-nitrophenol do not reveal potential carcinogenic effects.

The available data base is insufficient to establish an ambient water criterion for protection of human health from exposure to 2-nitrophenol. No data are available on which to evaluate the adverse effects of 2-nitrophenol on aquatic life.

Data on the behavior of 2-nitrophenol in POTW were not available. However, laboratory-scale studies have been conducted at concentrations higher than those expected to be found in municipal wastewater. Biochemical oxidation using adapted cultures from various sources produced 95 percent degradation in three to six days in one study. Similar results were reported for other studies. Based on these data, and general observations relating molecular structure to ease of biological oxidation, it is expected that 2-nitrophenol will be biochemically oxidized to a lesser extent than domestic sewage by biological treatment in POTWs.

4-Nitrophenol (58). 4-Nitrophenol ($\text{NO}_2\text{C}_6\text{H}_4\text{OH}$). also called paranitrophenol, is a colorless to yellowish crystalline solid manufactured commercially by hydrolysis of 4-chloro-nitrobenzene with aqueous sodium hydroxide. 4-Nitrophenol melts at 114°C . Vapor pressure is not cited in the usual sources. 4-Nitrophenol is slightly soluble in water (15 mg/l at 25°C) and soluble in organic solvents. This phenol does not react to give a color with 4-aminoantipyrene, and therefore does not contribute to the nonconventional pollutant parameter "Total Phenols." U.S. annual production is about 20,000 tons.

Paranitrophenol is used to prepare phenetidine, acetaphenetidine, azo and sulfur dyes, photochemicals, and pesticides.

The toxic effects of 4-nitrophenol on humans have not been extensively studied. Data from experiments with laboratory animals indicate that exposure to this compound results in methemoglobinemia (a metabolic disorder of blood), shortness of breath, and stimulation followed by depression. Other studies indicate that the compound acts directly on cell membranes, and inhibits certain enzyme systems in vitro. No information regarding potential teratogenicity was found. Available data indicate that this compound does not pose a mutagenic hazard to humans. Very limited data for 4-nitrophenol do not reveal potential carcinogenic effects, although the compound has been selected by the National Cancer Institute for testing under the Carcinogenic Bioassay Program.

No U.S. standards for exposure to 4-nitrophenol in ambient water have been established.

Data on the behavior of 4-nitrophenol in a POTW are not available. However, laboratory-scale studies have been conducted

at concentrations higher than those expected to be found in municipal wastewaters. Biochemical oxidation using adapted cultures from various sources produced 95 percent degradation in three to six days in one study. Similar results were reported for other studies. Based on these data, and on general observations relating molecular structure to ease of biological oxidation, it is concluded that complete or nearly complete removal of 4-nitrophenol occurs during biological treatment in a POTW.

2,4-Dinitrophenol (59). 2,4-Dinitrophenol ($C_6H_4N_2O_5$), a yellow crystalline solid, is manufactured by hydrolysis of 2,4-dinitro-1-chlorobenzene with sodium hydroxide. 2,4-Dinitrophenol sublimes at $114^{\circ}C$. Vapor pressure is not cited in usual sources. It is slightly soluble in water (7.0 mg/l at $25^{\circ}C$) and soluble in organic solvents. This phenol does not react with 4-aminoantipyrine and therefore does not contribute to the nonconventional pollutant parameter "Total Phenols." U.S. annual production is about 500 tons.

2,4-Dinitrophenol is used to manufacture sulfur and azo dyes, photochemicals, explosives, and pesticides.

The toxic effects of 2,4-dinitrophenol in humans is generally attributed to their ability to uncouple oxidative phosphorylation. In brief, this means that sufficient 2,4-dinitrophenol short-circuits cell metabolism by preventing utilization of energy provided by respiration and glycolysis. Specific symptoms are gastrointestinal disturbances, weakness, dizziness, headache, and loss to weight. More acute poisoning includes symptoms such as: burning thirst, agitation, irregular breathing, and abnormally high fever. This compound also inhibits other enzyme systems, and acts directly on the cell membrane, inhibiting chloride permeability. Ingestion of 2,4-dinitrophenol also causes cataracts in humans.

Based on available data it appears unlikely that 2,4-dinitrophenol poses a teratogenic hazard to humans. Results of studies of mutagenic activity of this compound are inconclusive as far as humans are concerned. Available data suggest that 2,4-dinitrophenol does not possess carcinogenic properties.

To protect human health from the adverse effects of 2,4-dinitrophenol ingested in contaminated water and fish, the suggested water quality criterion is 0.0686 mg/l.

Data on the behavior of 2,4-dinitrophenol in a POTW are not available. However, laboratory-scale studies have been conducted at concentrations higher than those expected to be found in municipal wastewaters. Biochemical oxidation using a phenol-adapted seed culture produced 92 percent degradation in 3.5 hours. Similar results were reported for other studies. Based on these data, and on general observations relating molecular structure to ease of biological oxidation, it is concluded that complete or nearly complete removal of 2,4-dinitrophenol occurs

during biological treatment in a POTW.

4,6-Dinitro-o-cresol (60). 4,6-Dinitro-o-cresol (DNOC) is a yellow crystalline solid derived from o-cresol. DNOC melts at 85.8°C and has a vapor pressure of 0.000052 mm Hg at 20°C. DNOC is sparingly soluble in water (100 mg/l at 20°C), while it is readily soluble in alkaline aqueous solutions, ether, acetone, and alcohol. DNOC is produced by sulfonation of o-cresol followed by treatment with nitric acid.

DNOC is used primarily as a blossom thinning agent on fruit trees and as a fungicide, insecticide, and miticide on fruit trees during the dormant season. It is highly toxic to plants in the growing stage. DNOC is not manufactured in the U.S. as an agricultural chemical. Imports of DNOC have been decreasing recently with only 30,000 pounds imported in 1976.

While DNOC is highly toxic to plants, it is also very toxic to humans and is considered to be one to the more dangerous agricultural pesticides. The available literature concerning humans indicates that DNOC may be absorbed in acutely toxic amounts through the respiratory and gastrointestinal tracts and through the skin, and that it accumulates in the blood. Symptoms of poisoning include profuse sweating, thirst, loss of weight, headache, malaise, and yellow staining to the skin, hair, sclera, and conjunctiva.

There is no evidence to suggest that DNOC is teratogenic, mutagenic, or carcinogenic. The effects of DNOC in the human due to chronic exposure are basically the same as those effects resulting from acute exposure. Although DNOC is considered a cumulative poison in humans, cataract formation is the only chronic effect noted in any human or experimental animal study. It is believed that DNOC accumulates in the human body and that toxic symptoms may develop when blood levels exceed 20 mg/kg.

For the protection of human health from the toxic properties of dinitro-o-cresol ingested through water and contaminated aquatic organisms, the ambient water criterion is determined to be 0.0134 mg/l. If contaminated aquatic organisms alone are consumed, excluding the consumption of water, the ambient water criterion is determined to be 0.765 mg/l. No data are available on which to evaluate the adverse effects of 4,6-dinitro-o-cresol on aquatic life.

Some studies have been reported regarding the behavior of DNOC in POTW. Biochemical oxidation of DNOC under laboratory conditions at a concentration of 100 mg/l produced 22 percent degradation in 3.5 hours, using acclimated phenol adapted seed cultures. In addition, the nitro group in the number 4 (para) position seems to impart a destabilizing effect on the molecule. Based on these data and general conclusions relating molecular structure to biochemical oxidation, it is expected that 4,6-dinitro-o-cresol will be biochemically oxidized to a lesser extent than domestic sewage by biological treatment in POTW.

N-nitrosodiphenylamine (62). N-nitrosodiphenylamine $[(C_6H_5)_2NNO]$, also called nitrous diphenylamide, is a yellow crystalline solid manufactured by nitrosation of diphenylamine. It melts at $66^\circ C$ and is insoluble in water, but soluble in several organic solvents other than hydrocarbons. Production in the U.S. has approached 1,500 tons per year. The compound is used as a retarder for rubber vulcanization and as a pesticide for control of scorch (a fungus disease of plants).

N-nitroso compounds are acutely toxic to every animal species tested and are also poisonous to humans. N-nitrosodiphenylamine toxicity in adult rats lies in the mid range of the values for 60 N-nitroso compounds tested. Liver damage is the principal toxic effect. N-nitrosodiphenylamine, unlike many other N-nitrosoamines, does not show mutagenic activity. N-nitrosodiphenylamine has been reported by several investigations to be non-carcinogenic. However, the compound is capable of trans-nitrosation and could thereby convert other amines to carcinogenic N-nitrosoamines. Sixty-seven of 87 N-nitrosoamines studied were reported to have carcinogenic activity. No water quality criteria have been proposed for N-nitrosodiphenylamine.

No data are available on the behavior of N-nitrosodiphenylamine in a POTW. Biochemical oxidation of many of the toxic organic pollutants have been investigated, at least in laboratory-scale studies, at concentrations higher than those expected to be contained in most municipal wastewaters. General observations have been developed relating molecular structure to ease of degradation for all the toxic organic pollutants. The conclusion reached by study of the limited data is that biological treatment produces little or no removal of N-nitrosodiphenylamine in a POTW. No information is available regarding possible interference by N-nitrosodiphenylamine in POTW processes, or on the possible detrimental effect on sludge used to amend soils in which crops are grown. However, no interference or detrimental effects are expected because N-nitroso compounds are widely distributed in the soil and water environment, at low concentrations, as a result of microbial action on nitrates and nitrosatable compounds.

Pentachlorophenol (64). Pentachlorophenol (C_6Cl_5OH) is a white crystalline solid produced commercially by chlorination of phenol or polychlorophenols. U.S. annual production is in excess of 20,000 tons. Pentachlorophenol melts at $190^\circ C$ and is slightly soluble in water (14 mg/l). Pentachlorophenol is not detected by the 4-amino antiprene method.

Pentachlorophenol is a bactericide and fungicide and is used for preservation of wood and wood products. It is competitive with creosote in that application. It is also used as a preservative in glues, starches, and photographic papers. It is an effective algicide and herbicide.

Although data are available on the human toxicity effects of

pentachlorophenol, interpretation of data is frequently uncertain. Occupational exposure observations must be examined carefully because exposure to pentachlorophenol is frequently accompanied by exposure to other wood preservatives. Additionally, experimental results and occupational exposure observations must be examined carefully to make sure that observed effects are produced by the pentachlorophenol itself and not by the by-products which usually contaminate pentachlorophenol.

Acute and chronic toxic effects of pentachlorophenol in humans are similar: muscle weakness, headache, loss of appetite, abdominal pain, weight loss, and irritation of skin, eyes, and respiratory tract. Available literature indicates that pentachlorophenol does not accumulate in body tissues to any significant extent. Studies on laboratory animals of distribution of the compound in body tissues showed the highest levels of pentachlorophenol in liver, kidney, and intestine, while the lowest levels were in brain, fat, muscle, and bone.

Toxic effects of pentachlorophenol in aquatic organisms are much greater at pH 6 where this weak acid is predominantly in the undissociated form than at pH 9 where the ionic form predominates. Similar results were observed in mammals where oral lethal doses of pentachlorophenol were lower when the compound was administered in hydrocarbon solvents (un-ionized form) than when it was administered as the sodium salt (ionized form) in water.

There appear to be no significant teratogenic, mutagenic, or carcinogenic effects of pentachlorophenol.

For the protection of human health from the toxic properties of pentachlorophenol ingested through water and through contaminated aquatic organisms, the ambient water quality criterion is determined to be 0.140 mg/l.

Only limited data are available for reaching conclusions about the behavior of pentachlorophenol in a POTW. Pentachlorophenol has been found in the influent to a POTW. In a study of one POTW the mean removal was 59 percent over a seven-day period. Trickling filters removed 44 percent at the influent pentachlorophenol, suggesting that biological degradation occurs. The same report compared removal of pentachlorophenol at the same plant and two additional POTW facilities on a later date and obtained values of 4.4, 19.5, and 28.6 percent removal, the last value being for the plant which was 59 percent removal in the original study. Influent concentrations of pentachlorophenol ranged from 0.0014 to 0.0046 mg/l. Other studies, including the general review of data relating molecular structure to biological oxidation, indicate that pentachlorophenol is not removed by biological treatment processes in a POTW. Anaerobic digestion processes are inhibited by 0.4 mg/l pentachlorophenol.

The low water solubility and low volatility of pentachlorophenol

lead to the expectation that most of the compound will remain in the sludge in a POTW. The effect on plants grown on land treated with pentachlorophenol-containing sludge is unpredictable. Laboratory studies show that this compound affects crop germination at 5.4 mg/l. However, photodecomposition of pentachlorophenol occurs in sunlight. The effects of the various breakdown products which may remain in the soil were not found in the literature.

Phenol (65). Phenol, also called hydroxybenzene and carbolic acid, is a clear, colorless, hygroscopic, deliquescent, crystalline solid at room temperature. Its melting point is 43°C and its vapor pressure at room temperature is 0.35 mm Hg. It is very soluble in water (67 gm/l at 1°C) and can be dissolved in benzene, oils, and petroleum solids. Its formula is C₆H₅OH.

Although a small percent of the annual production of phenol is derived from coal tar as a naturally occurring product, most of the phenol is synthesized. Two of the methods are fusion of benzene sulfonate with sodium hydroxide, and oxidation of cumene followed by cleavage with a catalyst. Annual production in the U.S. is in excess of one million tons. Phenol is generated during distillation of wood and the microbiological decomposition of organic matter in the mammalian intestinal tract.

Phenol is used as a disinfectant, in the manufacture of resins, dyestuffs, and in pharmaceuticals, and in the photo processing industry. In this discussion, phenol is the specific compound which is separated by methylene chloride extraction of an acidified sample and identified and quantified by GC/MS. Phenol also contributes to the "Total Phenols," discussed elsewhere which are determined by the 4-AAP colorimetric method.

Phenol exhibits acute and sub-acute toxicity in humans and laboratory animals. Acute oral doses of phenol in humans cause sudden collapse and unconsciousness by its action on the central nervous system. Death occurs by respiratory arrest. Sub-acute oral doses in mammals are rapidly absorbed and quickly distributed to various organs, then cleared from the body by urinary excretion and metabolism. Long-term exposure by drinking phenol-contaminated water has resulted in a statistically significant increase in reported cases of diarrhea, mouth sores, and burning of the mouth. In laboratory animals, long-term oral administration at low levels produced slight liver and kidney damage. No reports were found regarding carcinogenicity of phenol administered orally -- all carcinogenicity studies were skin test.

For the protection of human health from phenol ingested through water and through contaminated aquatic organisms, the concentration in water should not exceed 3.4 mg/l.

Fish and other aquatic organisms demonstrated a wide range of sensitivities to phenol concentration. However, acute toxicity

values were at moderate levels when compared to other toxic organic pollutants.

Data have been developed on the behavior of phenol in a POTW. Phenol is biodegradable by biota present in a POTW. The ability of a POTW to treat phenol-bearing influents depends upon acclimation of the biota and the constancy of the phenol concentration. It appears that an induction period is required to build up the population of organisms which can degrade phenol. Too large a concentration will result in upset or pass through in the POTW, but the specific level causing upset depends on the immediate past history of phenol concentrations in the influent. Phenol levels as high as 200 mg/l have been treated with 95 percent removal in a POTW, but more or less continuous presence of phenol is necessary to maintain the population of microorganisms that degrade phenol.

Phenol which is not degraded is expected to pass through the POTW because of its very high water solubility. However, in a POTW where chlorination is practiced for disinfection of the POTW effluent, chlorination of phenol may occur. The products of that reaction may be toxic pollutants.

The EPA has developed data on influent and effluent concentrations of total phenols in a study of 103 POTW facilities. However, the analytical procedure was the 4-AAP method mentioned earlier and not the GC/MS method specifically for phenol. Discussion of the study, which of course includes phenol, is presented under the pollutant heading "Total Phenols."

Phthalate Esters (66-71). Phthalic acid or 1,2-benzenedicarboxylic acid, is one of three isomeric benzenedicarboxylic acids produced by the chemical industry. The other two isomeric forms are called isophthalic and terephthalic acids. The formula for all three acids is $C_6H_4(COOH)_2$. Some esters of phthalic acid are designated as toxic pollutants. They will be discussed as a group here, and specific properties of individual phthalate esters will be discussed afterwards.

Phthalic acid esters are manufactured in the U.S. at an annual rate in excess of one billion pounds. They are used as plastiizers, primarily in the production of polyvinyl chloride (PVC) resins. The most widely used phthalate plasticizer is bis(2ethylhexyl) phthalate (66) which accounts for nearly one-third of the phthalate esters produced. This particular ester is commonly referred to as dioctyl phthalate (DOP) and should not be confused with one of the less used esters, di-n-octyl phthalate (69), which is also used as a plasticizer. In addition to these two isomeric dioctyl phthalates, four other esters, also used primarily as plasticizers, are designated as toxic pollutants. They are: butyl benzyl phthalate (67), di-n-butyl phthalate (68), diethyl phthalate (70), and dimethyl phthalate (71).

Industrially, phthalate esters are prepared from phthalic anhydride and the specific alcohol to form the ester. Some

evidence is available suggesting that phthalic acid esters also may be synthesized by certain plant and animal tissues. The extent to which this occurs in nature is not known.

Phthalate esters used as plasticizers can be present in concentrations up to 60 percent of the total weight of the PVC plastic. The plasticizer is not linked by primary chemical bonds to the PVC resin. Rather, it is locked into the structure of intermeshing polymer molecules and held by van der Waals forces. The result is that the plasticizer is easily extracted. Plasticizers are responsible for the odor associated with new plastic toys or flexible sheet that has been contained in a sealed package.

Although the phthalate esters are not soluble or are only very slightly soluble in water, they do migrate into aqueous solutions placed in contact with the plastic. Thus, industrial facilities with tank linings, wire and cable coverings, tubing, and sheet flooring of PVC are expected to discharge some phthalate esters in their raw waste. In addition to their use as plasticizers, phthalate esters are used in lubricating oils and pesticide carriers. These also can contribute to industrial discharge of phthalate esters.

From the accumulated data on acute toxicity in animals, phthalate esters may be considered as having a rather low order of toxicity. Human toxicity data are limited. It is thought that the toxic effects of the esters is most likely due to one of the metabolic products, in particular the monoester. Oral acute toxicity in animals is greater for the lower molecular weight esters than for the higher molecular weight esters.

Orally administered phthalate esters generally produced enlarging of liver and kidney, and atrophy of testes in laboratory animals. Specific esters produced enlargement of heart and brain, splenitis, and degeneration of central nervous system tissue.

Sub-acute doses administered orally to laboratory animals produced some decrease in growth and degeneration of the testes. Chronic studies in animals showed similar effects to those found in acute and sub-acute studies, but to a much lower degree. The same organs were enlarged, but pathological changes were not usually detected.

A recent study of several phthalic esters produced suggestive but not conclusive evidence that dimethyl and diethyl phthalates have a cancer liability. Only four of the six toxic pollutant esters were included in the study. Phthalate esters do bioconcentrate in fish. The factors, weighted for relative consumption of various aquatic and marine food groups, are used to calculate ambient water quality criteria for four phthalate esters. The values are included in the discussion of the specific esters.

Studies of toxicity of phthalate esters in freshwater and salt water organisms are scarce. A chronic toxicity test with bis(2-

ethylhexyl) phthalate showed that significant reproductive impairment occurred at 0.003 mg/l in the freshwater crustacean, Daphnia magna. In acute toxicity studies, saltwater fish and organisms showed sensitivity differences of up to eight-fold to butyl benzyl, diethyl and dimethyl phthalates. This suggests that each ester must be evaluated individually for toxic effects.

The behavior of phthalate esters in a POTW has not been studied. However, the biochemical oxidation of many of the toxic organic pollutants has been investigated in laboratory-scale studies at concentrations higher than would normally be expected in municipal wastewaters. Three of the phthalate esters were studied. Bis(2-ethylhexyl) phthalate was found to be degraded slightly or not at all and its removal by biological treatment in a POTW is expected to be slight or zero. Di-n-butyl phthalate and diethyl phthalate were degraded to a moderate degree and their removal by biological treatment in a POTW is expected to occur to a moderate degree. Using these data and other observations relating molecular structure to ease of biochemical degradation of other toxic organic pollutants, the conclusion was reached that butyl benzyl phthalate and dimethyl phthalate would be removed in a POTW to a moderate degree by biological treatment. On the same basis, it was concluded that di-n-octyl phthalate would be removed to a slight degree or not at all. An EPA study of seven POTW facilities revealed that for all but di-n-octyl phthalate, which was not studied, removals ranged from 62 to 87 percent.

No information was found on possible interference with POTW operation or the possible effects on sludge by the phthalate esters. The water - insoluble phthalate esters (butyl benzyl and di-n-octyl phthalate) would tend to remain in sludge, whereas the other four toxic pollutant phthalate esters with water solubilities ranging from 50 mg/l to 4.5 mg/l would probably pass through into the POTW effluent.

Bis(2-ethylhexyl) Phthalate (66). In addition to the general remarks and discussion on phthalate esters, specific information on bis(2-ethylhexyl) phthalate is provided. Little information is available about the physical properties of bis(2-ethylhexyl) phthalate. It is a liquid boiling at 387°C at 5 mm Hg and is insoluble in water. Its formula is $C_6H_4(COOC_8H_{17})_2$. This toxic pollutant constitutes about one-third of the phthalate ester production in the U.S. It is commonly referred to as dioctyl phthalate, or DOP, in the plastics industry where it is the most extensively used compound for the plasticization of polyvinyl chloride (PVC). Bis(2-ethylhexyl) phthalate has been approved by the FDA for use in plastics in contact with food. Therefore, it may be found in wastewaters coming in contact with discarded plastic food wrappers as well as the PVC films and shapes normally found in industrial plants. This toxic pollutant is also a commonly used organic diffusion pump oil, where its low vapor pressure is an advantage.

For the protection of human health from the toxic properties of

bis(2-ethylhexyl) phthalate ingested through water and through contaminated aquatic organisms, the ambient water quality criterion is determined to be 15 mg/l. If contaminated aquatic organisms alone are consumed, excluding the consumption of water, the ambient water criteria is determined to be 50 mg/l.

Although the behavior of bis(2-ethylhexyl) phthalate in a POTW has not been studied, biochemical oxidation of this toxic pollutant has been studied on a laboratory scale at concentrations higher than would normally be expected in municipal wastewater. In fresh water with a non-acclimated seed culture, no biochemical oxidation was observed after 5, 10, and 20 days. However, with an acclimated seed culture, biological oxidation occurred to the extents of 13, 0, 6, and 23 percent of theoretical after 5, 10, 15, and 20 days, respectively. Bis(2-ethylhexyl) phthalate concentrations were 3 to 10 mg/l. Little or no removal of bis(2-ethylhexyl) phthalate by biological treatment in a POTW is expected.

Butyl Benzyl Phthalate (67). In addition to the general remarks and discussion on phthalate esters, specific information on butyl benzyl phthalate is provided. No information was found on the physical properties of this compound.

Butyl benzyl phthalate is used as a plasticizer for PVC. Two special applications differentiate it from other phthalate esters. It is approved by the U.S. FDA for food contact in wrappers and containers, and it is the industry standard for plasticization of vinyl flooring because it provides stain resistance.

No ambient water quality criterion is proposed for butyl benzyl phthalate.

Butyl benzyl phthalate removal in a POTW by biological treatment is expected to occur to a moderate degree.

Di-n-butyl Phthalate (68). In addition to the general remarks and discussion on phthalate esters, specific information on di-n-butyl phthalate (DBP) is provided. DBP is a colorless oil liquid, boiling at 340°C. Its water solubility at room temperature is reported to be 0.4 g/l and 4.5 g/l in two different chemistry handbooks. The formula for DBP, $C_6H_4(COOC_4H_9)_2$ is the same as for its isomer, di-isobutyl phthalate. DBP production is 1 to 2 percent of total U.S. phthalate ester production.

Dibutyl phthalate is used to a limited extent as a plasticizer for polyvinyl chloride (PVC). It is not approved for contact with food. It is used in liquid lipsticks and as a dilluent for polysulfide dental impression materials. DBP is used as a plasticizer for nitrocellulose in making gun powder, and as a fuel in solid propellants for rockets. Further uses are insecticides, safety glass manufacture, textile lubricating agents, printing inks, adhesives, paper coatings, and resin

solvents.

For protection of human health from the toxic properties of dibutyl phthalate ingested through water and through contaminated aquatic organisms, the ambient water quality criterion is determined to be 34 mg/l. If contaminated aquatic organisms alone are consumed, excluding the consumption of water, the ambient water criterion is 154 mg/l.

Although the behavior of di-n-butyl phthalate in a POTW has not been studied, biochemical oxidation of this toxic pollutant has been studied on a laboratory scale at concentrations higher than would normally be expected in municipal wastewaters. Biochemical oxidation of 35, 43, and 45 percent of theoretical oxidation were obtained after 5, 10, and 20 days, respectively, using sewage microorganisms as an unacclimated seed culture.

Biological treatment in a POTW is expected to remove di-n-butyl phthalate to a moderate degree.

Di-n-octyl Phthalate (69). In addition to the general remarks and discussion on phthalate esters, specific information on di-n-octyl phthalate is provided. Di-n-octyl phthalate is not to be confused with the isomeric bis(2-ethylhexyl) phthalate which is commonly referred to in the plastics industry as DOP. Di-n-octyl phthalate is a liquid which boils at 220°C at 5 mm Hg. It is insoluble in water. Its molecular formula is $C_6H_4(COOC_8H_{17})_2$. Its production constitutes about 1 percent of all phthalate ester production in the U.S.

Industrially, di-n-octyl phthalate is used to plasticize polyvinyl chloride (PVC) resins.

No ambient water quality criterion is proposed for di-n-octyl phthalate.

Biological treatment in a POTW is expected to lead to little or no removal of di-n-octyl phthalate.

Diethyl Phthalate (70). In addition to the general remarks and discussion on phthalate esters, specific information on diethyl phthalate is provided. Diethyl phthalate, or DEP, is a colorless liquid boiling at 296°C, and is insoluble in water. Its molecular formula is $C_6H_4(COOC_2H_5)_2$. Production of diethyl phthalate constitutes about 1.5 percent of phthalate ester production in the U.S.

Diethyl phthalate is approved for use in plastic food containers by the U.S. FDA. In addition to its use as a polyvinyl chloride (PVC) plasticizer, DEP is used to plasticize cellulose nitrate for gun powder, to dilute polysulfide dental impression materials and as an accelerator for dyeing triacetate fibers. An additional use which would contribute to its wide distribution in the environment is as an approved special denaturant for ethyl alcohol. The alcohol-containing products for which DEP is an

approved denaturant include a wide range of personal care items such as bath preparations, bay rum, colognes, hair preparations, face and hand creams, perfumes and toilet soaps. Additionally, this denaturant is approved for use in biocides, cleaning solutions, disinfectants, insecticides, fungicides, and room deodorants which have ethyl alcohol as part of the formulation. It is expected, therefore, that people and buildings would have some surface loading of this toxic pollutant which would find its way into raw wastewaters.

For the protection of human health from the toxic properties of diethyl phthalate ingested through water and through contaminate aquatic organisms, the ambient water quality criterion is determined to be 350 mg/l. If contaminated aquatic organisms alone are consumed, excluding the consumption of water, the ambient water criterion is 1,800 mg/l.

Although the behavior of diethyl phthalate in a POTW has not been studied, biochemical oxidation of this toxic pollutant has been studied on a laboratory scale at concentrations higher than would normally be expected in municipal wastewaters. Biochemical oxidation of 79, 84, and 89 percent of theoretical was observed after 5, 15, and 20 days, respectively. Biological treatment in a POTW is expected to lead to a moderate degree of removal of diethyl phthalate.

Dimethyl Phthalate (71). In addition to the general remarks and discussion on phthalate esters, specific information on dimethyl phthalate (DMP) is provided. DMP has the lowest molecular weight of the phthalate esters - M.W. = 194 compared to M.W. of 391 for bis(2-ethylhexyl) phthalate. DMP has a boiling point of 282°C. It is a colorless liquid, soluble in water to the extent of 5 mg/l. its molecular formula is $C_6H_4(COOCH_3)_2$.

Dimethyl phthalate production in the U.S. is just under 1 percent of total phthalate ester production. DMP is used to some extent as a plasticizer in cellulose; however, its principal specific use is for dispersion of polyvinylidene fluoride (PVDF). PVDF is resistant to most chemicals and finds use as electrical insulation, chemical process equipment (particularly pipe), and as a case for long-life finishes for exterior metal siding. Coil coating techniques are used to apply PVDF dispersions to aluminum or galvanized steel siding.

For the protection of human health from the toxic properties of dimethyl phthalate ingested through water and through contaminated aquatic organisms, the ambient water criterion is determined to be 313 mg/l. If contaminated aquatic organisms alone are consumed excluding the consumption of water, the ambient water criterion is 2,900 mg/l.

Based on limited data and observations relating molecular structure to ease of biochemical degradation of other toxic organic pollutants, it is expected that dimethyl phthalate will be biochemically oxidized to a lesser extent than domestic sewage

by biological treatment in a POTW.

Polynuclear Aromatic Hydrocarbons (72-84). The polynuclear aromatic hydrocarbons (PAH) selected as toxic pollutants are a group of 13 compounds consisting of substituted and unsubstituted polycyclic aromatic rings. These compounds and their structural formulae are shown in Figure VI-3 (page 143). The general class of PAH includes heterocyclics, but none of those were selected as toxic pollutants. PAH are formed as the result of incomplete combustion when organic compounds are burned with insufficient oxygen. PAH are found in coke oven emissions, vehicular emissions, and volatile products of oil and gas burning. The compounds chosen as toxic pollutants are listed with their structural formulae and melting points (m.p.). All are relatively insoluble in water.

Some of these toxic pollutants have commercial or industrial uses. Benzo(a)anthracene, benzo(a)pyrene, chrysene, anthracene, dibenzo(a,h)anthracene, and pyrene are all used as antioxidants. Chrysene, acenaphthylene, anthracene, fluorene, phenanthrene, and pyrene are all used for synthesis of dyestuffs or other organic chemicals. 3,4-Benzofluoranthrene, benzo(k)fluoranthene, benzo(ghi)perylene, and indeno (1,2,3-cd)pyrene have no known industrial uses, according to the results of a recent literature search.

Several of the PAH toxic pollutants are found in smoked meats, in smoke flavoring mixtures, in vegetable oils, and in coffee. Consequently, they are also found in many drinking water supplies. The wide distribution of these pollutants in complex mixtures with the many other PAHs which have not been designated as toxic pollutants results in exposures to humans that cannot be associated with specific individual compounds.

The screening and verification analysis procedures used for the toxic organic pollutants are based on gas chromatography (GC). Three pairs of the PAH have identical elution times on the column specified in the protocol, which means that the parameters of the pair are not differentiated. For these three pairs [anthracene (78) - phenanthrene (81); 3,4-benzofluoranthene (74) - benzo(k)-fluoranthene (75); and benzo(a)anthracene (72) - chrysene (76)] results are obtained and reported as "either-or." Either both are present in the combined concentration reported, or one is present in the concentration reported.

There are no studies to document the possible carcinogenic risks to humans by direct ingestion. Air pollution studies indicate an excess of lung cancer mortality among workers exposed to large amounts of PAH containing materials such as coal gas, tars, and coke-oven emissions. However, no definite proof exists that the PAH present in these materials are responsible for the cancers observed.

Animal studies have demonstrated the toxicity of PAH by oral and dermal administration. The carcinogenicity of PAH has been

traced to formation of PAH metabolites which, in turn, lead to tumor formation. Because the levels of PAH which induce cancer are very low, little work has been done on other health hazards resulting from exposure. It has been established in animal studies that tissue damage and systemic toxicity can result from exposure to non-carcinogenic PAH compounds.

Because there were no studies available regarding chronic oral exposures to PAH mixtures, proposed water quality criteria were derived using data on exposure to a single compound. Two studies were selected, one involving benzo(a)pyrene ingestion and one involving dibenzo(a,h)anthracene ingestion. Both are known animal carcinogens.

For the maximum protection of human health from the potential carcinogenic effects of exposure to polynuclear aromatic hydrocarbons (PAH) through ingestion of water and contaminated aquatic organisms, the ambient water concentration is zero. Concentrations of PAH estimated to result in additional risk of 1 in 100,000 were derived by the EPA and the Agency is considering setting criteria at an interim target risk level in the range of 10^{-7} , 10^{-6} , or 10^{-5} with corresponding criteria of 0.000000097 mg/l, 0.00000097 mg/l, and 0.0000097 mg/l, respectively.

No standard toxicity tests have been reported for freshwater or saltwater organisms and any of the 13 PAH discussed here.

The behavior of PAH in a POTW has received only a limited amount of study. It is reported that up to 90 percent of PAH entering a POTW will be retained in the sludge generated by conventional sewage treatment processes. Some of the PAH can inhibit bacterial growth when they are present at concentrations as low as 0.018 mg/l. Biological treatment in activated sludge units has been shown to reduce the concentration of phenanthrene and anthracene to some extent; however, a study of biochemical oxidation of fluorene on a laboratory scale showed no degradation after 5, 10, and 20 days. On the basis of that study and studies of other toxic organic pollutants, some general observations were made relating molecular structure to ease of degradation. Those observations lead to the conclusion that the 13 PAH selected to represent that group as toxic pollutants will be removed only slightly or not at all by biological treatment methods in a POTW. Based on their water insolubility and tendency to attach to sediment particles, very little pass through of PAH to POTW effluent is expected. Sludge contamination is the likely environmental fate, although no data are available at this time to support any conclusions about contamination of land by PAH on which sewage sludge containing PAH is spread.

Tetrachloroethylene (85). Tetrachloroethylene ($\text{CCl}_2\text{sCCl}_2$), also called perchloroethylene and PCE, is a colorless, nonflammable liquid produced mainly by two methods - chlorination and pyrolysis of ethane and propane, and oxychlorination of dichloroethane. U.S. annual production exceeds 300,000 tons. PCE boils at 121°C , a vapor pressure of 19 mm Hg at 20°C . It is

insoluble in water but soluble in organic solvents.

Approximately two-thirds of the U.S. production of PCE is used for dry cleaning. Textile processing and metal degreasing, in equal amounts consume about one-quarter of the U.S. production.

The principal toxic effect of PCE on humans is central nervous system depression when the compound is inhaled. Headache, fatigue, sleepiness, dizziness, and sensations of intoxication are reported. Severity of effects increases with vapor concentration. High integrated exposure (concentration times duration) produces kidney and liver damage. Very limited data on PCE ingested by laboratory animals indicate liver damage occurs when PCE is administered by that route. PCE tends to distribute to fat in mammalian bodies.

One report found in the literature suggests, but does not conclude, that PCE is teratogenic. PCE has been demonstrated to be a liver carcinogen in B6C3-F1 mice.

For the maximum protection of human health from the potential carcinogenic effects of exposure to tetrachlorethylene through ingestion of water and contaminated aquatic organisms, the ambient water concentration is zero. Concentrations of tetrachloroethylene estimated to result in additional lifetime cancer risk levels of 10^{-7} , 10^{-6} , and 10^{-5} are 0.00002 mg/l, 0.0002 mg/l, and 0.002 mg/l, respectively.

No data were found regarding the behavior of PCE in a POTW. Many of the toxic organic pollutants have been investigated, at least in laboratory-scale studies, at concentrations higher than those expected to be contained by most municipal wastewaters. General observations have been developed relating molecular structure to ease of degradation for all of the toxic organic pollutants. The conclusion reached by the study of the limited data is that biological treatment produces a moderate removal of PCE in a POTW by degradation. No information was found to indicate that PCE accumulates in the sludge, but some PCE is expected to be adsorbed onto settling particles. Some PCE is expected to be volatilized in aerobic treatment processes and little, if any, is expected to pass through into the effluent from the POTW.

Toluene (86). Toluene is a clear, colorless liquid with a benzene-like odor. It is a naturally occurring compound derived primarily from petroleum or petrochemical processes. Some toluene is obtained from the manufacture of metallurgical coke. Toluene is also referred to as toluol, methylbenzene, methacide, and phenylmethane. It is an aromatic hydrocarbon with the formula $C_6H_5CH_3$. It boils at $111^\circ C$ and has a vapor pressure of Hg at room temperature. The water solubility of toluene is 535 mg/l, and it is miscible with a variety of organic solvents. Annual production of toluene in the U.S. is greater than two million metric tons. Approximately two-thirds of the toluene is converted to benzene and the remaining 30 percent is divided approximately equally into chemical manufacture, and use as a

paint solvent and aviation gasoline additive. An estimated 5,000 metric tons is discharged to the environment annually as a constituent in wastewater.

Most data on the effects of toluene in human and other mammals have been based on inhalation exposure or dermal contact studies. There appear to be no reports of oral administration of toluene to human subjects. A long-term toxicity study on female rats revealed no adverse effects on growth, mortality, appearance and behavior, organ to body weight ratios, blood-urea nitrogen levels, bone marrow counts, peripheral blood counts, or morphology of major organs. The effects of inhaled toluene on the central nervous system, both at high and low concentrations, have been studied in humans and animals. However, ingested toluene is expected to be handled differently by the body because it is absorbed more slowly and must first pass through the liver before reaching the nervous system. Toluene is extensively and rapidly metabolized in the liver. One of the principal metabolic products of toluene is benzoic acid, which itself seems to have little potential to produce tissue injury.

Toluene does not appear to be teratogenic in laboratory animals or man. Nor is there any conclusive evidence that toluene is mutagenic. Toluene has not been demonstrated to be positive in any in vitro mutagenicity or carcinogenicity bioassay system, nor to be carcinogenic in animals or man.

Toluene has been found in fish caught in harbor waters in the vicinity of petroleum and petrochemical plants. Bioconcentration studies have not been conducted, but bioconcentration factors have been calculated on the basis of the octanol-water partition coefficient.

For the protection of human health from the toxic properties of toluene ingested through water and through contaminated aquatic organisms, the ambient water criterion is determined to be 14.3 mg/l. If contaminated aquatic organisms alone are consumed excluding the consumption of water, the ambient water criterion is 424 mg/l. Available data show that the adverse effects on aquatic life occur at concentrations as low as 5 mg/l.

Acute toxicity tests have been conducted with toluene and a variety of freshwater fish and Daphnia magna. The latter appears to be significantly more resistant than fish. No test results have been reported for the chronic effects of toluene on freshwater fish or invertebrate species.

No detailed study of toluene behavior in a POTW is available. However, the biochemical oxidation of many of the toxic pollutants has been investigated in laboratory scale studies at concentrations greater than those expected to be contained by most municipal wastewaters. At toluene concentrations ranging from 3 to 250 mg/l biochemical oxidation proceeded to 50 percent of theoretical or greater. The time period varied from a few hours to 20 days depending on whether or not the seed culture was

acclimated. Phenol adapted acclimated seed cultures gave the most rapid and extensive biochemical oxidation.

Based on study of the limited data, it is expected that toluene will be biochemically oxidized to a lesser extent than domestic sewage by biological treatment in a POTW. The volatility and relatively low water solubility of toluene lead to the expectation that aeration processes will remove significant quantities of toluene from the POTW. The EPA studied toluene removal in seven POTW facilities. The removals ranged from 40 to 100 percent. Sludge concentrations of toluene ranged from 54×10^{-3} to 1.85 mg/l.

Trichloroethylene (87). Trichloroethylene (1,1,2-trichloroethylene or TCE) is a clear, colorless liquid boiling at 87°C. It has a vapor pressure of 77 mm Hg at room temperature and is slightly soluble in water (1 gm/l). U.S. production is greater than 0.25 million metric tons annually. It is produced from tetrachloroethane by treatment with lime in the presence of water.

TCE ($\text{CHCl}=\text{CCl}_2$) is used for vapor phase degreasing of metal parts, cleaning and drying electronic components, as a solvent for paints, as a refrigerant, for extraction of oils, fats, and waxes, and for dry cleaning. Its widespread use and relatively high volatility result in detectable levels in many parts of the environment.

Data on the effects produced by ingested TCE are limited. Most studies have been directed at inhalation exposure. Nervous system disorders and liver damage are frequent results of inhalation exposure. In the short term exposures, TCE acts as a central nervous system depressant - it was used as an anesthetic before its other long-term effects were defined.

TCE has been shown to induce transformation in a highly sensitive in vitro Fischer rat embryo cell system (F1706) that is used for identifying carcinogens. Severe and persistent toxicity to the liver was recently demonstrated when TCE was shown to produce carcinoma of the liver in mouse strain B6C3F1. One systematic study of TCE exposure and the incidence of human cancer was based on 518 men exposed to TCE. The authors of that study concluded that although the cancer risk to man cannot be ruled out, exposure to low levels of TCE probably does not present a very serious and general cancer hazard.

TCE is bioconcentrated in aquatic species, making the consumption of such species by humans a significant source of TCE. For the protection of human health from the potential carcinogenic effects of exposure to trichloroethylene through ingestion of water and contaminated aquatic organisms, the ambient water concentration is zero. Concentrations of trichloroethylene estimated to result in additional lifetime cancer risks of 10^{-7} , 10^{-6} , and 10^{-5} are 0.00027 mg/l, 0,0027 mg/l, and 0,027 mg/l, respectively. If contaminated aquatic organisms alone are

consumed, excluding the consumption of water, the water concentration should be less than 0.807 mg/l to keep the additional lifetime cancer risk below 10^{-5} .

Only a very limited amount of data on the effects of TCE on freshwater aquatic life are available. One species of fish (fat-head minnows) showed a loss of equilibrium at concentrations below those resulting in lethal effects.

The behavior of trichloroethylene in a POTW has not been studied. However, in laboratory-scale studies of toxic organic pollutants, TCE was subjected to biochemical oxidation conditions. After 5, 10, and 20 days no biochemical oxidation occurred. On the basis of this study and general observations relating molecular structure to ease of degradation, the conclusion is reached that TCE would undergo no removal by biological treatment in a POTW. The volatility and relatively low water solubility of TCE is expected to result in volatilization of some of the TCE in aeration steps in a POTW.

Vinyl Chloride (88). No freshwater organisms have been tested with vinyl chloride and no statement can be made concerning acute or chronic toxicity.

For the maximum protection of human health from the potential carcinogenic effects due to exposure of vinyl chloride through ingestion of contaminated water and contaminated aquatic organisms, the ambient water concentrations should be zero based on the non-threshold assumption for this chemical. However, zero level may not be attainable at the present time. Therefore, the levels which may result in incremental increase of cancer risk over the lifetime are estimated at 10^{-5} , 10^{-6} , and 10^{-7} . The corresponding recommended criteria are 0.020 mg/l, 0.0020 mg/l, and 0.00020 mg/l, respectively. For consumption of aquatic organisms only, excluding consumption of water, the levels are 5.246 mg/l, 0.525 mg/l, and 0.052 mg/l, respectively.

Vinyl chloride has been used for over 40 years in producing polyvinyl chloride (PVC) which in turn is the most widely used material in the manufacture of plastics throughout the world. Of the estimated 18 billion pounds of vinyl chloride produced worldwide in 1972, about 25 percent was manufactured in the United States. Production of vinyl chloride in the United States reached slightly over 5 billion pounds in 1978.

Vinyl chloride and polyvinyl chloride are used in the manufacture of numerous products in building and construction, the automotive industry, for electrical wire insulation and cables, piping, industrial and household equipment, packaging for food products, medical supplies, and is depended upon heavily by the rubber, paper, and glass industries. Polyvinyl chloride and vinyl chloride copolymers are distributed and processed in a variety of forms including dry resins, plastisol (dispersions in plasticizers), organosol (dispersions in plasticizers plus volatile solvent), and latex (colloidal dispersion in water).

Latexes are used to coat or impregnate paper, fabric, or leather.

Vinyl chloride (CH_2CHCl : molecular weight 62.5) is a highly flammable chloroolefinic hydrocarbon which emits a sweet or pleasant odor and has a vapor density slightly more than twice that of air. It has a boiling point of -13.9°C and a melting point of -153.8°C . Its solubility in water at 28°C is 0.11 g/100 g water and it is soluble in alcohol and very soluble in ether and carbon tetrachloride. Vinyl chloride is volatile and readily passes from solution into the gas phase under most laboratory and ecological conditions. Many salts such as soluble silver and copper salts, ferrous chloride, platinous chloride, iridium dichloride, and mercurous chloride to name a few, have the ability to form complexes with vinyl chloride which results in its increased solubility in water. Conversely, alkali metal salts such as sodium or potassium chloride may decrease the solubility of vinyl chloride in ionic strengths of the aqueous solution. Therefore, the amounts of vinyl chloride in water could be influenced significantly by the presence of salts.

Vinyl chloride introduced into aquatic systems will most probably be quickly transferred to the atmosphere through volatilization. In fact, results from model simulations indicate that vinyl chloride should not remain in an aquatic ecosystem under most natural conditions.

Based on the information found, it does not appear that oxidation hydrolysis, biodegradation or sorption, are important fate processes for vinyl chloride in the aquatic environment.

Based on the 1982 POTW study, "Fate of Priority Pollutants in Publicly Owned Treatment Works, Final Report," Effluent Guidelines Division, U.S. Environmental Protection Agency, EPA 440/1-82/303, September 1983, the removal efficiency for vinyl chloride at a POTW with secondary treatment is 94 percent.

4,4'-DDD (94). 4,4'-DDD is toxic by ingestion, inhalation, skin absorption, and is combustible.

a-Endosulfan-alpha (95). Endosulfan is toxic by ingestion, inhalation and skin absorption.

a-BHC-alpha (102). BHC-alpha is toxic by ingestion, skin absorption, is an eye irritant, and a central nervous system depressant.

b-BHC-beta (103). BHC-beta is moderately toxic by inhalation, highly toxic by ingestion, and is a strong irritant by skin absorption. It acts as a central nervous system depressant.

Polychlorinated Biphenyls (106 - 112). Polychlorinated biphenyls ($\text{C}_{12}\text{H}_{10-n}\text{Cl}_n$, $\text{H}_{10-n}\text{Cl}_n$ where n can range from 1 to 10), designated PCBs, are chlorinated derivatives of biphenyls. The commercial products are complex mixtures of chlorobiphenyls, but are no longer produced in the U.S. The mixtures produced formerly were

characterized by the percentage chlorination. Direct chlorination of biphenyl was used to produce mixtures containing from 21 to 70 percent chlorine. Seven of these mixtures have been selected as toxic pollutants:

Toxic Pollu- tant No.	Name	Percent Chlorine	Range (°C) Distilla- tion	Pour Point (°C)	Water Solubility
	Arochlor				
106	1242	42	325-366	-19	240
107	1254	54	365-390	10	12
108	1221	20.5-21.5	275-320	1	<200
109	1232	31.4-32.5	290-325	-35.5	--
110	1248	48	340-375	-7	54
111	1260	60	385-420	31	2.7
112	1016	41	323-356	--	225-250

The arochlors 1221, 1232, 1016, 1242, and 1248 are colorless, oily liquids; 1254 is a viscous liquid; 1260 is a sticky resin at room temperature. Total annual U.S. production of PCBs averaged about 20,000 tons in 1972 to 1974.

Prior to 1971, PCBs were used in several applications including plasticizers, heat transfer liquids, hydraulic fluids, lubricants, vacuum pump and compressor fluids, and capacitor and transformer oils. After 1970, when PCB use was restricted to closed systems, the latter two uses were the only commercial applications.

The toxic effects of PCB's ingested by humans have been reported to range from acne-like skin eruptions and pigmentation of the skin to numbness of limbs, hearing and vision problems, and spasms. Interpretation of results is complicated by the fact that the very highly toxic polychlorinated dibenzofurans (PCDFs) are found in many commercial PCB mixtures. Photochemical and thermal decomposition appear to accelerate the transformation of PCBs to PCDFs. Thus the specific effects of PCBs may be masked by the effects of PCDFs. However, if PCDFs are frequently present to some extent in any PCB mixture, then their effects may be properly included in the effects of PCB mixtures.

Studies of effects of PCBs in laboratory animals indicate that liver and kidney damage, large weight losses, eye discharges, and interference with some metabolic processes occur frequently. Teratogenic effects of PCBs in laboratory animals have been observed, but are rare. Growth retardations during gestation, and reproductive failure are more common effects observed in studies of PCB teratogenicity. Carcinogenic effects of PCBs have been studied in laboratory animals with results interpreted as positive. Specific reference has been made to liver cancer in rats in the discussion of water quality criterion formulation.

For the maximum protection of human health from the potential

For the maximum protection of human health from the potential carcinogenic effects of exposure to PCBs through ingestion of water and contaminated aquatic organisms, the ambient water concentration should be zero. Concentrations of PCBs estimated to result in additional lifetime cancer risk at risk levels of 10^{-7} , 10^{-6} , and 10^{-5} are 0.000000026 mg/l, 0.00000026 mg/l, and 0.0000026 mg/l, respectively.

The behavior of PCBs in a POTW has received limited study. Most PCB's will be removed with sludge. One study showed removals of 82 to 89 percent, depending on suspended solid removal. The PCB's adsorb onto suspended sediments and other particulates. In laboratory-scale experiments with PC8 1221, 81 percent was removed by degradation in an activated sludge system in 47 hours. Biodegradation can form polychlorinated dibenzofurans which are more toxic than PCBs (as noted earlier). PCBs at concentrations of 0.1 to 1,000 mg/l inhibit or enhance bacterial growth rates, depending on the bacterial culture and the percentage chlorine in the PCB. Thus, activated sludge may be inhibited by PCBs. Based on studies of bioaccumulation of PCBs in food crops grown on soils amended with PCB-containing sludge, the U.S. FDA has recommended a limit of 10 mg PCB/kg dry weight of sludge used for application to soils bearing food crops.

Antimony (114). Antimony, classified as a non-metal or metalloid, is a silvery white, brittle crystalline solid. Antimony is found in small ore bodies throughout the world. Principal ores are oxides of mixed antimony valences, and an oxysulfide ore. Complex ores with metals are important because the antimony is recovered as a by-product. Antimony melts at 631°C , and is a poor conductor of electricity and heat.

Annual U.S. consumption of primary antimony ranges from 10,000 to 20,000 tons. About half is consumed in metal products - mostly antimonial lead for lead acid storage batteries, and about half in non-metal products. A principal compound is antimony trioxide which is used as a flame retardant in fabrics, and as an opacifier in glass, ceramics, and enamels. Several antimony compounds are used as catalysts in organic chemicals synthesis, as fluorinating agents (the antimony fluoride), as pigments, and in fireworks. Semiconductor applications are economically significant.

Essentially no information on antimony-induced human health effects has been derived from community epidemiology studies. The available data are in literature relating effects observed with therapeutic or medicinal uses of antimony compounds and industrial exposure studies. Large therapeutic doses of antimonial compounds, usually used to treat schistosomiasis, have caused severe nausea, vomiting, convulsions, irregular heart action, liver damage, and skin rashes. Studies of acute industrial antimony poisoning have revealed loss of appetite, diarrhea, headache, and dizziness in addition to the symptoms found in studies of therapeutic doses of antimony.

For the protection of human health from the toxic properties of antimony ingested through water and through contaminated aquatic organisms the ambient water criterion is determined to be 0.146 mg/l. If contaminated aquatic organisms are consumed, excluding the consumption of water, the ambient water criterion is determined to be 45 mg/l. Available data show that adverse effects on aquatic life occur at concentrations higher than those cited for human health risks.

Very little information is available regarding the behavior of antimony in a POTW. The limited solubility of most antimony compounds expected in a POTW (i.e., the oxides and sulfides), suggests that at least part of the antimony entering a POTW will be precipitated and incorporated into the sludge. However, some antimony is expected to remain dissolved and pass through the POTW into the effluent. Antimony compounds remaining in the sludge under anaerobic conditions may be connected to stibine (SbH_3), a very soluble and very toxic compound. There are no data to show antimony inhibits any POTW processes. Antimony is not known to be essential to the growth of plants, and has been reported to be moderately toxic. Therefore, sludge containing large amounts of antimony could be detrimental to plants if it is applied in large amounts to cropland.

Arsenic (115). Arsenic is classified as a non-metal or metalloid. Elemental arsenic normally exists in the alpha-crystalline metallic form which is steel gray and brittle, and in the beta form which is dark gray and amorphous. Arsenic sublimes at 615°C . Arsenic is widely distributed throughout the world in a large number of minerals. The most important commercial source of arsenic is as a by-product from treatment of copper, lead, cobalt, and gold ores. Arsenic is usually marketed as the trioxide (As_2O_3). Annual U.S. production of the trioxide approaches 40,000 tons.

The principal use of arsenic is in agricultural chemicals (herbicides) for controlling weeds in cotton fields. Arsenicals have various applications in medicinal and veterinary use, as wood preservatives, and in semiconductors.

The effects of arsenic in humans were known by the ancient Greeks and Romans. The principal toxic effects are gastrointestinal disturbances. Breakdown of red blood cells occurs. Symptoms of acute poisoning include vomiting, diarrhea, abdominal pain lassitude, dizziness, and headache. Longer exposure produced dry, falling hair, brittle, loose nails, eczema, and exfoliation. Arsenicals also exhibit teratogenic and mutagenic effects in humans. Oral administration of arsenic compounds has been associated clinically with skin cancer for nearly one hundred years. Since 1888 numerous studies have linked occupational exposure and therapeutic administration of arsenic compounds to increased incidence of respiratory and skin cancer.

For the maximum protection of human health from the potential carcinogenic effects of exposure to arsenic through ingestion of

water and contaminated aquatic organisms, the ambient water concentration is zero. Concentrations of arsenic estimated to result in additional lifetime cancer risk levels of 10^{-7} , 10^{-6} , and 10^{-5} are 2.2×10^{-7} mg/l, 2.2×10^{-6} mg/l, and 2.2×10^{-5} mg/l, respectively. If contaminated aquatic organisms alone are consumed, excluding the consumption of water, the water concentration should be less than 1.75×10^{-4} to keep the increased lifetime cancer risk below 10^{-5} . Available data show that adverse effects on aquatic life occur at concentrations higher than those cited for human health risks.

A few studies have been made regarding the behavior of arsenic in a POTW. One EPA survey of nine POTW facilities reported influent concentrations ranging from 0.0005 to 0.693 mg/l; effluents from three POTW facilities having biological treatment contained 0.0004 to 0.01 mg/l; two POTW facilities showed arsenic removal efficiencies of 50 and 71 percent in biological treatment. Inhibition of treatment processes by sodium arsenate is reported to occur at 0.1 mg/l in activated sludge, and 1.6 mg/l in anaerobic digestion processes. In another study based on data from 60 POTW facilities, arsenic in sludge ranged from 1.6 to 65.6 mg/kg and the median value was 7.8 mg/kg. Arsenic in sludge spread on cropland may be taken up by plants grown on that land. Edible plants can take up arsenic, but normally their growth is inhibited before the plants are ready for harvest.

Asbestos (116). Asbestos is a generic term used to describe a group of hydrated mineral silicates that can appear in a fibrous crystal form (asbestiform) and, when crushed, can separate into flexible fibers. The types of asbestos presently used commercially fall into two mineral groups: the serpentine and amphibole groups. Asbestos is mineralogically stable and is not prone to significant chemical or biological degradation in the aquatic environment. In 1978, the total consumption of asbestos in the U.S. was 583,000 metric tons. Asbestos is an excellent insulating material and is used in a wide variety of products. Based on 1975 figures, the total annual identifiable asbestos emissions are estimated at 243,527 metric tons. Land discharges account for 98.3 percent of the emissions, air discharges account for 1.5 percent, and water discharges account for 0.2 percent.

Asbestos has been found to produce significant incidence of disease among workers occupationally exposed in mining and milling, in manufacturing, and in the use of materials containing the fiber. The predominant type of exposure has been inhalation, although some asbestos may be swallowed directly or ingested after being expectorated from the respiratory tract. Noncancerous asbestos has been found among people directly exposed to high levels of asbestos as a result of excessive work exposure; much less frequently, among those with lesser exposures although there is extensive evidence of pulmonary disease among people exposed to airborne asbestos. There is little evidence of disease among people exposed to waterborne fibers.

Asbestos at the concentrations currently found in the aquatic

environment does not appear to exert toxic effects on aquatic organisms. For the maximum protection of human health from the potential carcinogenic effects of exposure to asbestos through ingestion of water and contaminated aquatic organisms, the ambient water concentration should be zero based on the non-threshold assumption of this substance. However, zero level may not be attainable at the present time. Therefore, levels which may result in incremental increase of cancer risk over the life time are estimated at 10^{-5} , 10^{-6} , and 10^{-7} . The corresponding recommended criteria are 300,000 fibers/l, 30,000 fibers/l, and 3,000 fibers/l.

The available data indicate that technologies used at POTW for reducing levels of total suspended solids in wastewater also provide a concomitant reduction in asbestos levels. Asbestos removal efficiencies ranging from 80 percent to greater than 99 percent have been reported following sedimentation of wastewater. Filtration and sedimentation with chemical addition (i.e., lime and polymer) have achieved even greater percentage removals.

Beryllium (117). Beryllium is a dark gray metal of the alkaline earth family. It is relatively rare, but because of its unique properties finds widespread use as an alloying element, especially for hardening copper which is used in springs, electrical contacts and non-sparking tools. World production is reported to be in the range of 250 tons annually. However, much more reaches the environment as emissions from coal burning operations. Analysis of coal indicates an average beryllium content of 3 ppm and 0.1 to 1.0 percent in coal ash or fly ash.

The principal ores are beryl ($3\text{BeO}\cdot\text{Al}_2\text{O}_3\cdot 6\text{SiO}_2$) and bertrandite ($\text{Be}_4\text{Si}_2\text{O}_7(\text{OH})_2$). Only two industrial facilities produce beryllium in the U.S. because of limited demand and the highly toxic character. About two-thirds of the annual production goes into alloys, 20 percent into heat sinks, and 10 percent into beryllium oxide (BeO) ceramic products.

Beryllium has a specific gravity of 1.846, making it the lightest metal with a high melting point ($1,350^\circ\text{C}$). Beryllium alloys are corrosion resistant, but the metal corrodes in aqueous environments. Most common beryllium compounds are soluble in water, at least to the extent necessary to produce a toxic concentration of beryllium ions.

Most data on toxicity of beryllium is for inhalation of beryllium oxide dust. Some studies on orally administered beryllium in laboratory animals have been reported. Despite the large number of studies implicating beryllium as a carcinogen, there is no recorded instance of cancer being produced by ingestion. However, a recently convened panel of uninvolved experts concluded that epidemiologic evidence is suggestive that beryllium is a carcinogen in man.

In the aquatic environment, beryllium is chronically toxic to aquatic organisms at 0.0053 mg/l. Water softness has a large

effect on beryllium toxicity to fish. In soft water, beryllium is reportedly 100 times as toxic as in hard water.

For the maximum protection of human health from the potential carcinogenic effects of exposure to beryllium through ingestion of water and contaminated aquatic organisms the ambient water concentration is zero. Concentrations of beryllium estimated to result in additional lifetime cancer risk levels of 10^{-7} , 10^{-6} , and 10^{-5} are 0.00000068 mg/l, 0.0000068 mg/l, and 0.000068 mg/l, respectively. If contaminated aquatic organisms alone are consumed excluding the consumption of water, the concentration should be less than 0.00115 mg/l to keep the increased lifetime cancer risk below 10^{-5} .

Information on the behavior of beryllium in a POTW is scarce. Because beryllium hydroxide is insoluble in water, most beryllium entering a POTW will probably be in the form of suspended solids. As a result, most of the beryllium will settle and be removed with sludge. However, beryllium has been shown to inhibit several enzyme systems, to interfere with DNA metabolism in liver, and to induce chromosomal and mitotic abnormalities. This interference in cellular processes may extend to interfere with biological treatment processes. The concentration and effects of beryllium in sludge which could be applied to cropland have not been studied.

Cadmium (118). Cadmium is a relatively rare metallic element that is seldom found in sufficient quantities in a pure state to warrant mining or extraction from the earth's surface. It is found in trace amounts of about 1 ppm throughout the earth's crust. Cadmium is, however, a valuable by-product of zinc production.

Cadmium is used primarily as an electroplated metal and is found as an impurity in the secondary refining of zinc, lead, and copper.

Cadmium is an extremely dangerous cumulative toxicant, causing progressive chronic poisoning in mammals, fish, and probably other organisms. The metal is not excreted.

Toxic effects of cadmium on man have been reported from throughout the world. Cadmium may be a factor in the development of such human pathological conditions as kidney disease, testicular tumors, hypertension, arteriosclerosis, growth inhibition, chronic disease of old age, and cancer. Cadmium is normally ingested by humans through food and water as well as by breathing air contaminated by cadmium dust. Cadmium is cumulative in the liver, kidney, pancreas, and thyroid of humans and other animals.

A severe bone and kidney syndrome known as ita-ita disease has been documented in Japan as caused by cadmium ingestion via drinking water and contaminated irrigation water. Ingestion of as little as 0.6 mg/day has produced the disease. Cadmium acts synergistically with other metals. Copper and zinc substantially

increase its toxicity.

Cadmium is concentrated by marine organisms, particularly mollusks, which accumulate cadmium in calcareous tissues and in the viscera. A concentration factor of 1,000 for cadmium in fish muscle has been reported, as have concentration factors of 3,000 in marine plants and up to 29,600 in certain marine animals. The eggs and larvae of fish are apparently more sensitive than adult fish to poisoning by cadmium, and crustaceans appear to be more sensitive than fish eggs and larvae.

For the protection of human health from the toxic properties of cadmium ingested through water and through contaminated aquatic organisms, the ambient water criterion is determined to be 0.010 mg/l. Available data show that adverse effects on aquatic life occur at concentrations in the same range as those cited for human health, and they are highly dependent on water hardness.

Cadmium is not destroyed when it is introduced into a POTW, and will either pass through to the POTW effluent or be incorporated into the POTW sludge. In addition, it can interfere with the POTW treatment process.

In a study of 189 POTW facilities, 75 percent of the primary plants, 57 percent of the trickling filter plants, 66 percent of the activated sludge plants, and 62 percent of the biological plants allowed over 90 percent of the influent cadmium to pass through to the POTW effluent. Only two of the 189 POTW facilities allowed less than 20 percent pass-through, and none less than 10 percent pass-through. POTW effluent concentrations ranged from 0.001 to 1.97 mg/l (mean 0.028 mg/l, standard deviation 0.167 mg/l).

Cadmium not passed through the POTW will be retained in the sludge where it is likely to build up in concentration. Cadmium contamination of sewage sludge limits its use on land since it increases the level of cadmium in the soil. Data show that cadmium can be incorporated into crops, including vegetables and grains, from contaminated soils. Since the crops themselves show no adverse effects from soils with levels up to 100 mg/kg cadmium, these contaminated crops could have a significant impact on human health. Two Federal agencies have already recognized the potential adverse human health effects posed by the use of sludge on cropland. The FDA recommends that sludge containing over 30 mg/kg of cadmium should not be used on agricultural land. Sewage sludge contains 3 to 300 mg/kg (dry basis) of cadmium (mean = 10 mg/kg, median = 16 mg/kg). The USDA also recommends placing limits on the total cadmium from sludge that may be applied to land.

Chromium (119). Chromium is an elemental metal usually found as a chromite ($\text{FeO} \cdot \text{Cr}_2\text{O}_3$). The metal is normally produced by reducing the oxide with aluminum. A significant proportion of the chromium used is in the form of compounds such as sodium dichromate (Na_2CrO_4), and chromic acid (CrO_3) - both are

hexavalent chromium compounds.

Chromium is found as an alloying component of many steels and its compounds are used in electroplating baths and as corrosion inhibitors for closed water circulation systems.

The two chromium forms most frequently found in industry wastewaters are hexavalent and trivalent chromium. Hexavalent chromium is the form used for metal treatments. Some of it is reduced to trivalent chromium as part of the process reaction. The raw wastewater containing both valence states is usually treated first to reduce remaining hexavalent to trivalent chromium, and second to precipitate the trivalent form as the hydroxide. The hexavalent form is not removed by lime treatment.

Chromium, in its various valence states, is hazardous to man. It can produce lung tumors when inhaled, and induces skin sensitizations. Large doses of chromates have corrosive effects on the intestinal tract and can cause inflammation of the kidneys. Hexavalent chromium is a known human carcinogen. Levels of chromate ions that show no effect in man appear to be so low as to prohibit determination, to date.

The toxicity of chromium salts to fish and other aquatic life varies widely with the species, temperature, pH, valence of the chromium, and synergistic or antagonistic effects, especially the effect of water hardness. Studies have shown that trivalent chromium is more toxic to fish of some types than is hexavalent chromium. Hexavalent chromium retards growth of one fish species at 0.0002 mg/l. Fish food organisms and other lower forms of aquatic life are extremely sensitive to chromium. Therefore, both hexavalent and trivalent chromium must be considered harmful to particular fish or organisms.

For the protection of human health from the toxic properties of chromium (except hexavalent chromium) ingested through water and contaminated aquatic organisms, the ambient water quality criterion is 170 mg/l. If contaminated aquatic organisms alone are consumed excluding the consumption of water, the ambient water criterion for trivalent chromium is 3,443 mg/l. The ambient water quality criterion for hexavalent chromium is recommended to be identical to the existing drinking water standard for total chromium which is 0.050 mg/l.

Chromium is not destroyed when treated by a POTW (although the oxidation state may change), and will either pass through to the POTW effluent or be incorporated into the POTW sludge. Both oxidation states can cause POTW treatment inhibition and can also limit the usefulness of municipal sludge.

Influent concentrations of chromium to POTW facilities have been observed by EPA to range from 0.005 to 14.0 mg/l, with a median concentration of 0.1 mg/l. The efficiencies for removal of chromium by the activated sludge process can vary greatly, depending on chromium concentration in the influent, and other

operating conditions at the POTW. Chelation of chromium by organic matter and dissolution due to the presence of carbonates can cause deviations from the predicted behavior in treatment systems.

The systematic presence of chromium compounds will halt nitrification in a POTW for short periods, and most of the chromium will be retained in the sludge solids. Hexavalent chromium has been reported to severely affect the nitrification process, but trivalent chromium has little or no toxicity to activated sludge, except at high concentrations. The presence of iron, copper, and low pH will increase the toxicity of chromium in a POTW by releasing the chromium into solution to be ingested by microorganisms in the POTW.

The amount of chromium which passes through to the POTW effluent depends on the type of treatment processes used by the POTW. In a study of 240 POTW facilities, 56 percent of the primary plants allowed more than 80 percent pass-through to POTW effluent. More advanced treatment results in less pass-through. POTW effluent concentrations ranged from 0.003 to 3.2 mg/l total chromium (mean = 0.197, standard deviation = 0.48), and from 0.002 to 0.1 mg/l hexavalent chromium (mean = 0.017, standard deviation = 0.020).

Chromium not passed through the POTW will be retained in the sludge, where it is likely to build up in concentration. Sludge concentrations of total chromium of over 20,000 mg/kg (dry basis) have been observed. Disposal of sludges containing very high concentrations of trivalent chromium can potentially cause problems in uncontrolled landfills. Incineration, or similar destructive oxidation processes, can produce hexavalent chromium from lower valence states. Hexavalent chromium is potentially more toxic than trivalent chromium. In cases where high rates of chrome sludge application on land are used, distinct growth inhibition and plant tissue uptake have been noted.

Pretreatment of discharges substantially reduces the concentration of chromium in sludge. In Buffalo, New York, pretreatment of electroplating waste resulted in a decrease in chromium concentrations in POTW sludge from 2,510 to 1,040 mg/kg. A similar reduction occurred in Grand Rapids, Michigan, POTW facilities where the chromium concentration in sludge decreased from 11,000 to 2,700 mg/kg when pretreatment was made a requirement.

Copper (120). Copper is a metallic element that sometimes is found free, as the native metal, and is also found in minerals such as cuprite (Cu_2O , malechite [$\text{CuCO}_3 \cdot \text{Cu}(\text{OH})_2$], azurite [$2\text{CuCO}_3 \cdot \text{Cu}(\text{OH})_2$], chalcopyrite (CuFeS_2), and bornite (Cu_5FeS_4). Copper is obtained from these ores by smelting, leaching, and electrolysis. It is used in the plating, electrical, plumbing, and heating equipment industries, as well as in insecticides and fungicides.

Traces of copper are found in all forms of plant and animal life,

and the metal is an essential trace element for nutrition. Copper is not considered to be a cumulative systemic poison for humans as it is readily excreted by the body, but it can cause symptoms of gastroenteritis, with nausea and intestinal irritations, as relatively low dosages. The limiting factor in domestic water supplies is taste. To prevent this adverse organoleptic effect of copper in water, a criterion of 1 mg/l has been established.

The toxicity of copper to aquatic organisms varies significantly, not only with the species, but also with the physical and chemical characteristics of the water including temperature, hardness, turbidity, and carbon dioxide content. In hard water, the toxicity of copper salts may be reduced by the precipitation of copper carbonate or other insoluble compounds. The sulfates of copper and zinc, and of copper and calcium are synergistic in their toxic effect on fish.

Relatively high concentrations of copper may be tolerated by adult fish for short periods of time; the critical effect of copper appears to be its higher toxicity to young or juvenile fish. Concentrations of 0.02 to 0.03 mg/l have proved fatal to some common fish species. In general, the salmonoids are very sensitive and the sunfishes are less sensitive to copper.

The recommended criterion to protect freshwater aquatic life is 0.0056 mg/l as a 24-hour average, and 0.012 mg/l maximum concentration at a hardness of 50 mg/l CaCO_3 . For total recoverable copper, the criterion to protect freshwater aquatic life is 0.0056 mg/l as a 24-hour average.

Copper salts cause undesirable color reactions in the food industry and cause pitting when deposited on some other metals such as aluminum and galvanized steel. To control undesirable taste and odor quality of ambient water due to the organoleptic properties of copper, the estimated level is 1.0 mg/l for total recoverable copper.

Irrigation water containing more than minute quantities of copper can be detrimental to certain crops. Copper appears in all soils, and its concentration ranges from 10 to 80 ppm. In soils, copper occurs in association with hydrous oxides of manganese and iron, and also as soluble and insoluble complexes with organic matter. Copper is essential to the life of plants, and the normal range of concentration in plant tissue is from 5 to 20 ppm. Copper concentrations in plants normally do not build up to high levels when toxicity occurs. For example, the concentrations of copper in snapbean leaves and pods was less than 50 and 20 mg/kg, respectively, under conditions of severe copper toxicity. Even under conditions of copper toxicity, most of the excess copper accumulates in the roots; very little is moved to the aerial part of the plant.

Copper is not destroyed when treated by a POTW, and will either pass through to the POTW effluent or be retained in the POTW sludge. It can interfere with the POTW treatment processes and

can limit the usefulness of municipal sludge.

The influent concentration of copper to a POTW has been observed by the EPA to range from 0.01 to 1.97 mg/l, with a median concentration of 0.12 mg/l. The copper that is removed from the influent stream of a POTW is absorbed on the sludge or appears in the sludge as the hydroxide of the metal. Bench-scale pilot studies have shown that from about 25 percent to 75 percent of the copper passing through the activated sludge process remains in solution in the final effluent. Four-hour slug dosages of copper sulfate in concentrations exceeding 50 mg/l were reported to have severe effects on the removal efficiency of an unacclimated system, with the system returning to normal in about 100 hours. Slug dosages of copper in the form of copper cyanide were observed to have much more severe effects on the activated sludge system, but the total system returned to normal in 24 hours.

In a recent study of 268 POTW facilities, the median pass-through was over 80 percent for primary plants and 40 to 50 percent for trickling filter, activated sludge, and biological treatment plants. POTW effluent concentrations of copper ranged from 0.003 to 1.8 mg/l (mean = 0.126, standard deviation = 0.242).

Copper which does not pass through the POTW will be retained in the sludge where it will build up in concentration. The presence of excessive levels of copper in sludge may limit its use on cropland. Sewage sludge contains up to 16,000 mg/kg of copper, with 730 mg/kg as the mean value. These concentrations are significantly greater than those normally found in soil which usually range from 18 to 80 mg/kg. Experimental data indicate that when dried sludge is spread over tillable land, the copper tends to remain in place down to the depth of the tillage, except for copper which is taken up by plants grown in the soil. Recent investigation has shown that the extractable copper content of sludge-treated soil decreased with time, which suggests a reversion of copper to less soluble forms was occurring.

Cyanide (121). Cyanides are among the most toxic of pollutants commonly observed in industrial wastewaters. Introduction of cyanide into industrial processes is usually by dissolution of potassium cyanide (KCN) or sodium cyanide (NaCN) in process waters. However, hydrogen cyanide (HCN), formed when the above salts are dissolved in water, is probably the most acutely lethal compound.

The relationship of pH to hydrogen cyanide formation is very important. As pH is lowered to below 7, more than 99 percent of the cyanide is present as HCN and less than 1 percent as cyanide ions. Thus, at neutral pH, that of most living organisms, the more toxic form of cyanide prevails.

Cyanide ions combine with numerous heavy metal ions to form complexes. The complexes are in equilibrium with HCN. Thus, the stability of the metal-cyanide complex and the pH determine the

concentration of HCN. Stability of the metal-cyanide anion complexes is extremely variable. Those formed with zinc, copper, and cadmium are not stable - they rapidly dissociate, with production of HCN, in near neutral or acid waters. Some of the complexes are extremely stable. Cobaltocyanide is very resistant to acid distillation in the laboratory. Iron cyanide complexes are also stable, but undergo photodecomposition to give HCN upon exposure to sunlight. Synergistic effects have been demonstrated for the metal cyanide complexes making zinc, copper, and cadmium cyanides more toxic than an equal concentration of sodium cyanide.

The toxic mechanism of cyanide is essentially an inhibition of oxygen metabolism (i.e., rendering the tissues incapable of exchanging oxygen). The cyanogen compounds are true noncumulative protoplasmic poisons. They arrest the activity of all forms of animal life. Cyanide shows a very specific type of toxic action. It inhibits the cytochrome oxidase system. This system is the one which facilitates electron transfer from reduced metabolites to molecular oxygen. The human body can convert cyanide to a non-toxic thiocyanate and eliminate it. However, if the quantity of cyanide ingested is too great at one time, the inhibition of oxygen utilization proves fatal before the detoxifying reaction reduces the cyanide concentration to a safe level.

Cyanides are more toxic to fish than to lower forms of aquatic organisms such as midge larvae, crustaceans, and mussels. Toxicity to fish is a function of chemical form and concentration, and is influenced by the rate of metabolism (temperature), the level of dissolved oxygen, and pH. In laboratory studies, free cyanide concentrations ranging from 0.05 to 0.1g mg/l have been proven to be fatal to sensitive fish species including trout, bluegill, and fathead minnows. Levels above 0.2 mg/l are rapidly fatal to most fish species. Long-term sublethal concentrations of cyanide as low as 0.01 mg/l have been shown to affect the ability of fish to function normally (e.g., reproduce, grow, and swim).

For the protection of human health from the toxic properties of cyanide ingested through water and through contaminated aquatic organisms, the ambient water quality criterion is determined to be 0.200 mg/l.

Persistence of cyanide in water is highly variable and depends upon the chemical form of cyanide in the water, the concentration of cyanide, and the nature of other constituents. Cyanide may be destroyed by strong oxidizing agents such as permanganate and chlorine. Chlorine is commonly used to oxidize strong cyanide solutions. Carbon dioxide and nitrogen are the products of complete oxidation. But if the reaction is not complete, the very toxic compound, cyanogen chloride, may remain in the treatment system and subsequently be released to the environment. Partial chlorination may occur as part of a POTW treatment, or during the disinfection treatment of surface water for drinking water preparation.

Cyanides can interfere with treatment processes in a POTW, or pass through to ambient waters. At low concentrations and with acclimated microflora, cyanide may be decomposed by microorganisms in anaerobic and aerobic environments or waste treatment systems. However, data indicate that much of the cyanide introduced passes through to the POTW effluent. The mean pass-through of 14 biological plants was 71 percent. In a recent study of 41 POTW facilities the effluent concentrations ranged from 0.002 to 100 mg/l (mean = 2.518, standard deviation = 15.6). Cyanide also enhances the toxicity of metals commonly found in POTW effluents, including the toxic pollutants cadmium, zinc, and copper.

Data for Grand Rapids, Michigan, showed a significant decline in cyanide concentrations downstream from the POTW after pretreatment regulations were put in force. Concentrations fell from 0.66 mg/l before, to 0.01 mg/l after pretreatment was required.

Lead (122). Lead is a soft, malleable, ductile, blueish-gray, metallic element, usually obtained from the mineral galena (lead sulfide, PbS), anglesite (lead sulfate, PbSO₄), or cerussite (lead carbonate, PbCO₃). Because it is usually associated with minerals of zinc, silver, copper, gold, cadmium, antimony, and arsenic, special purification methods are frequently used before and after extraction of the metal from the ore concentrate by smelting.

Lead is widely used for its corrosion resistance, sound and vibration absorption, low melting point (solders), and relatively high imperviousness to various forms of radiation. Small amounts of copper, antimony and other metals can be alloyed with lead to achieve greater hardness, stiffness, or corrosion resistance than is afforded by the pure metal. Lead compounds are used in glazes and paints. About one third of U.S. lead consumption goes into storage batteries. About half of U.S. lead consumption is from secondary lead recovery. U.S. consumption of lead is in the range of one million tons annually.

Lead ingested by humans produces a variety of toxic effects including impaired reproductive ability, disturbances in blood chemistry, neurological disorders, kidney damage, and adverse cardiovascular effects. Exposure to lead in the diet results in permanent increase in lead levels in the body. Most of the lead entering the body eventually becomes localized in the bones where it accumulates. Lead is a carcinogen or cocarcinogen in some species of experimental animals. Lead is teratogenic in experimental animals. Mutagenicity data are not available for lead.

The ambient water quality criterion for lead is recommended to be identical to the existing drinking water standard which is 0.050 mg/l. Available data show that adverse effects on aquatic life occur at concentrations as low as 7.5×10^{-4} mg/l of total

recoverable lead as a 24-hour average with a water hardness of 50 mg/l as CaCO₃.

Lead is not destroyed in a POTW, but is passed through to the effluent or retained in the POTW sludge; it can interfere with POTW treatment processes and can limit the usefulness of POTW sludge for application to agricultural croplands. Threshold concentration for inhibition of the activated sludge process is 0.1 mg/l, and for the nitrification process is 0.5 mg/l. In a study of 214 POTW facilities, median pass-through values were over 80 percent for primary plants and over 60 percent for trickling filter, activated sludge, and biological process plants. Lead concentration in POTW effluents ranged from 0.003 to 1.8 mg/l (mean = 0.106 mg/l, standard deviation = 0.222).

Application of lead-containing sludge to cropland should not lead to uptake by crops under most conditions because normally lead is strongly bound by soil. However, under the unusual condition of low pH (less than 5.5) and low concentrations of labile phosphorus, lead solubility is increased and plants can accumulate lead.

Mercury (123). Mercury is an elemental metal rarely found in nature as the free metal. Mercury is unique among metals as it remains a liquid down to about 39 degrees below zero. It is relatively inert chemically and is insoluble in water. The principal ore is cinnabar (HgS).

Mercury is used industrially as the metal and as mercurous and mercuric salts and compounds. Mercury is used in several types of batteries. Mercury released to the aqueous environment is subject to biomethylation - conversion to the extremely toxic methyl mercury.

Mercury can be introduced into the body through the skin and the respiratory system as the elemental vapor. Mercuric salts are highly toxic to humans and can be absorbed through the gastrointestinal tract. Fatal doses can vary from 1 to 30 grams. Chronic toxicity of methyl mercury is evidenced primarily by neurological symptoms. Some mercuric salts cause death by kidney failure.

Mercuric salts are extremely toxic to fish and other aquatic life. Mercuric chloride is more lethal than copper, hexavalent chromium, zinc, nickel, and lead towards fish and aquatic life. In the food cycle, algae containing mercury up to 100 times the concentration in the surrounding sea water are eaten by fish which further concentrate the mercury. Predators that eat the fish in turn concentrate the mercury even further.

For the protection of human health from the toxic properties of mercury ingested through water and through contaminated aquatic organisms, the ambient water criterion is determined to be 0.0002 mg/l.

Mercury is not destroyed when treated by a POTW, and will either pass through to the POTW effluent or be incorporated into the POTW sludge. At low concentrations it may reduce POTW removal efficiencies. and at high concentrations it may upset the POTW operation.

The influent concentrations of mercury to a POTW have been observed by the EPA to range from 0.002 to 0.24 mg/l, with a median concentration of 0.001 mg/l. Mercury has been reported in the literature to have inhibiting effects upon an activated sludge POTW at levels as low as 0.1 mg/l. At 5 mg/l of mercury losses of COD removal efficiency of 14 to 40 percent have been reported, while at 10 mg/l, loss of removal of 59 percent has been reported. Upset of an activated sludge POTW is reported in the literature to occur near 200 mg/l. The anaerobic digestion process is much less affected by the presence of mercury, with inhibitory effects being reported at 1,365 mg/l.

In a study of 22 POTW facilities having secondary treatment, the range of removal of mercury from the influent to the POTW ranged from 4 to 99 percent with median removal of 41 percent. Thus significant pass-through of mercury may occur.

In sludges, mercury content may be high if industrial sources of mercury contamination are present. Little is known about the form in which mercury occurs in sludge. Mercury may undergo biological methylation in sediments, but no methylation has been observed in soils, mud, or sewage sludge.

The mercury content of soils not receiving additions of POTW sewage sludge lie in the range from 0.01 to 0.5 mg/kg. In soils receiving POTW sludges for protracted periods, the concentration of mercury has been observed to approach 1.0 mg/kg. In the soil, mercury enters into reactions with the exchange complex of clay and organic fractions, forming both ionic and covalent bonds. Chemical and microbiological degradation of mercurials can take place side by side in the soil, and the products - ionic or molecular - are retained by organic matter and clay or may be volatilized if gaseous. Because of the high affinity between mercury and the solid soil surfaces, mercury persists in the upper layer of the soil.

Mercury can enter plants through the roots, it can readily move to other parts of the plant, and it has been reported to cause injury to plants. In many plants mercury concentrations range from 0.01 to 0.20 mg/kg, but when plants are supplied with high levels of mercury, these concentrations can exceed 0.5 mg/kg. Bioconcentration occurs in animals ingesting mercury in food.

Nickel (124). Nickel is seldom found in nature as the pure elemental metal. It is a relatively plentiful element and is widely distributed throughout the earth's crust. It occurs in marine organisms and is found in the oceans. The chief commercial ores for nickel are pentlandite [(Fe,Ni)9S8], and a lateritic ore consisting of hydrated nickel-iron-magnesium

silicate.

Nickel has many and varied uses. It is used in alloys and as the pure metal. Nickel salts are used for electroplating baths.

The toxicity of nickel to man is thought to be very low, and systemic poisoning of human beings by nickel or nickel salts is almost unknown. In non-human mammals nickel acts to inhibit insulin release, depress growth, and reduce cholesterol. A high incidence of cancer of the lung and nose has been reported in humans engaged in the refining of nickel.

Nickel salts can kill fish at very low concentrations. However, nickel has been found to be less toxic to some fish than copper, zinc, and iron. Nickel is present in coastal and open ocean water at concentrations in the range of 0.0001 to 0.006 mg/l although the most common values are 0.002 to 0.003 mg/l. Marine animals contain up to 0.4 mg/l and marine plants contain up to 3 mg/l. Higher nickel concentrations have been reported to cause reduction in photosynthetic activity of the giant kelp. A low concentration was found to kill oyster eggs.

For the protection of human health based on the toxic properties of nickel ingested through water and through contaminated aquatic organisms, the ambient water criterion is determined to be 0.0134 mg/l. If contaminated aquatic organisms are consumed, excluding consumption of water, the ambient water criterion is determined to be 0.100 mg/l. Available data show that adverse effects on aquatic life occur for total recoverable nickel concentrations as low as 0.0071 mg/l as a 24-hour average.

Nickel is not destroyed when treated in a POTW, but will either pass through to the POTW effluent or be retained in the POTW sludge. It can interfere with POTW treatment processes and can also limit the usefulness of municipal sludge.

Nickel salts have caused inhibition of the biochemical oxidation of sewage in a POTW. In a pilot plant, slug doses of nickel significantly reduced normal treatment efficiencies for a few hours, but the plant acclimated itself somewhat to the slug dosage and appeared to achieve normal treatment efficiencies within 40 hours. It has been reported that the anaerobic digestion process is inhibited only by high concentrations of nickel, while a low concentration of nickel inhibits the nitrification process.

The influent concentration of nickel to a POTW has been observed by the EPA to range from 0.01 to 3.19 mg/l, with a median of 0.33 mg/l. In a study of 190 POTW facilities, nickel pass-through was greater than 90 percent for 82 percent of the primary plants. Median pass-through for trickling filter, activated sludge, and biological process plants was greater than 80 percent. POTW effluent concentrations ranged from 0.002 to 40 mg/l (mean = 0.410, standard deviation = 3.279).

Nickel not passed through the POTW will be incorporated into the sludge. In a recent two-year study of eight cities, four of the cities had median nickel concentrations of over 350 mg/kg, and two were over 1,000 mg/kg. The maximum nickel concentration observed was 4,010 mg/kg.

Nickel is found in nearly all soils, plants, and waters. Nickel has no known essential function in plants. In soils, nickel typically is found in the range from 10 to 100 mg/kg. Various environmental exposures to nickel appear to correlate with increased incidence of tumors in man. For example, cancer in the maxillary antrum of snuff users may result from using plant materials grown on soil high in nickel.

Nickel toxicity may develop in plants from application of sewage sludge on acid soils. Nickel has caused reduction of yields for a variety of crops including oats, mustard, turnips, and cabbage. In one study, nickel decreased the yields of oats significantly at 100 mg/kg.

Whether nickel exerts a toxic effect on plants depends on several soil factors, the amount of nickel applied, and the contents of other metals in the sludge. Unlike copper and zinc, which are more available from inorganic sources than from sludge, nickel uptake by plants seems to be promoted by the presence of the organic matter in sludge. Soil treatments, such as liming, reduce the solubility of nickel. Toxicity of nickel to plants is enhanced in acidic soils.

Selenium (125). Selenium is a non-metallic element existing in several allotropic forms. Gray selenium, which has a metallic appearance, is the stable form at ordinary temperatures and melts at 220°C. Selenium is a major component of 38 minerals and a minor component of 37 others found in various parts of the world. Most selenium is obtained as a by-product of precious metals recovery from electrolytic copper refinery slimes. U.S. annual production at one time reached one million pounds.

Principal uses of selenium are in semi-conductors, pigments, decoloring of glass, and metallurgy. It also is used to produce ruby glass used in signal lights. Several selenium compounds are important oxidizing agents in the synthesis of organic chemicals and drug products.

While results of some studies suggest that selenium may be an essential element in human nutrition, the toxic effects of selenium in humans are well established. Lassitude, loss of hair, discoloration and loss of fingernails are symptoms of selenium poisoning. In a fatal case of ingestion or a larger dose of selenium acid, peripheral vascular collapse, pulmonary edema, and coma occurred. Selenium produces mutagenic and teratogenic effects, but it has not been established as exhibiting carcinogenic activity.

For the protection of human health from the toxic properties of

selenium ingested through water and through contaminated aquatic organisms, the ambient water criterion is determined to be 0.010 mg/l, (i.e., the same as the drinking water standard). Available data show that adverse effects on aquatic life occur at concentrations higher than that cited for human toxicity.

Very few data are available regarding the behavior of selenium in a POTW. One EPA survey of 103 POTW facilities revealed one POTW using biological treatment and having selenium in the influent. Influent concentration was 0.0025 mg/l, and effluent concentration was 0.0016 mg/l, giving a removal of 37 percent. It is not known to be inhibitory to POTW processes. In another study, sludge from POTW facilities in 16 cities was found to contain from 1.8 to 8.7 mg/kg selenium, compared to 0.01 to 2 mg/kg in untreated soil. These concentrations of selenium in sludge present a potential hazard for humans or other mammals eating crops grown on soil treated with selenium-containing sludge.

Silver (126). Silver is a soft lustrous white metal that is insoluble in water and alkali. In nature, silver is found in the elemental state (native silver) and combined in ores such as argentite (Ag_2S), horn silver (AgCl), proustite (Ag_3AsS_3), and pyrargyrite (Ag_3SbS_3). Silver is used extensively in several industries, among them electroplating.

Metallic silver is not considered to be toxic, but most of its salts are toxic to a large number of organisms. Upon ingestion by humans, many silver salts are absorbed in the circulatory system and deposited in various body tissues, resulting in generalized or sometimes localized gray pigmentation of the skin and mucous membranes known as argyria. There is no known method for removing silver from the tissues once it is deposited, and the effect is cumulative.

Silver is recognized as a bactericide and doses from 0.000001 to 0.0005 mg/l have been reported as sufficient to sterilize water. The criterion for ambient water to protect human health from the toxic properties of silver ingested through water and through contaminated aquatic organisms is 0.010 mg/l.

The chronic toxic effects of silver on the aquatic environment have not been given as much attention as many other heavy metals. Data from existing literature support the fact that silver is very toxic to aquatic organisms. Despite the fact that silver is nearly the most toxic of the heavy metals, there are insufficient data to adequately evaluate even the effects of hardness on silver toxicity. There are no data available on the toxicity of different forms of silver.

There is no available literature on the incidental removal of silver by a POTW. An incidental removal of about 50 percent is assumed as being representative. This is the highest average incidental removal of any metal for which data are available. (Copper has been indicated to have a median incidental removal rate of 49 percent.)

Bioaccumulation and concentration of silver from sewage sludge has not been studied to any great degree. There is some indication that silver could be bioaccumulated in mushrooms to the extent that there could be adverse physiological effects on humans if they consumed large quantities of mushrooms grown in silver-enriched soil. The effect, however, would tend to be unpleasant rather than fatal.

There are little summary data available on the quantity of silver discharged to a POTW. Presumably there would be a tendency to limit its discharge from a manufacturing facility because of its high intrinsic value.

Thallium (127). Thallium is a soft, silver-white, dense, malleable metal. Five major minerals contain 15 to 85 percent thallium, but they are not of commercial importance because the metal is produced in sufficient quantity as a by-product of lead-zinc smelting of sulfide ores. Thallium melts at 304°C. U.S. annual production of thallium and its compounds is estimated to be 1,500 pounds.

Industrial uses of thallium include the manufacture of alloys, electronic devices and special glass. Thallium catalysts are used for industrial organic syntheses.

Acute thallium poisoning in humans has been widely described. Gastrointestinal pains and diarrhea are followed by abnormal sensation in the legs and arms, dizziness, and, later, loss of hair. The central nervous system is also affected. Somnolence, delirium or coma may occur. Studies on the teratogenicity of thallium appear inconclusive; no studies on mutagenicity were found; and no published reports on carcinogenicity of thallium were found.

For the protection of human health from the toxic properties of thallium ingested through water and contaminated aquatic organisms, the ambient water criterion is 0.004 mg/l.

No reports were found regarding the behavior of thallium in a POTW. It will not be degraded; therefore, it must pass through to the effluent or be removed with the sludge. However, since the sulfide (TlS) is very insoluble, if appreciable sulfide is present, dissolved thallium in the influent to a POTW may be precipitated into the sludge. Subsequent use of sludge bearing thallium compounds as a soil amendment to crop bearing soils may result in uptake of this element by food plants. Several leafy garden crops (cabbage, lettuce, leek, and endive) exhibit relatively higher concentrations of thallium than other foods such as meat.

Zinc (128). Zinc occurs abundantly in the earth's crust, concentrated in ores. It is readily refined into the pure, stable, silver-white metal. In addition to its use in alloys, zinc is used as a protective coating on steel. It is applied by

hot dipping (i.e., dipping the steel in molten zinc) or by electroplating.

Zinc can have an adverse effect on man and animals at high concentrations. Zinc at concentrations in excess of 5 mg/l causes an undesirable taste which persists through conventional treatment. For the prevention of adverse effects due to these organoleptic properties of zinc, 5 mg/l was adopted for the ambient water criterion. Available data show that adverse effects on aquatic life occur at concentrations as low as 0.047 mg/l as a 24-hour average.

Toxic concentrations of zinc compounds cause adverse changes in the morphology and physiology of fish. Lethal concentrations in the range of 0.1 mg/l have been reported. Acutely toxic concentrations induce cellular breakdown of the gills, and possibly the clogging of the gills with mucous. Chronically toxic concentrations of zinc compounds cause general enfeeblement and widespread histological changes to many organs, but not to gills. Abnormal swimming behavior has been reported at 0.04 mg/l. Growth and maturation are retarded by zinc. It has been observed that the effects of zinc poisoning may not become apparent immediately, so that fish removed from zinc-contaminated water may die as long as 48 hours after removal.

In general, salmonoids are most sensitive to elemental zinc in soft water; the rainbow trout is the most sensitive in hard waters. A complex relationship exists between zinc concentration, dissolved zinc concentration, pH, temperature, and calcium and magnesium concentration. Prediction of harmful effects has been less than reliable and controlled studies have not been extensively documented.

The major concern with zinc compounds in marine waters is not with acute lethal effects but rather with the long-term sub-lethal effects of the metallic compounds and complexes. Zinc accumulates in some marine species and marine animals contain zinc in the range of 6 to 1,500 mg/kg. From the point of view of acute lethal effects, invertebrate marine animals seem to be the most sensitive organism tested.

Toxicities of zinc in nutrient solutions have been demonstrated for a number of plants. A variety of fresh water plants tested manifested harmful symptoms at concentrations of 0.030 to 21.6 mg/l. Zinc sulfate has also been found to be lethal to many plants and it could impair agricultural uses of the water.

Zinc is not destroyed when treated by a POTW, but will either pass through to the POTW effluent or be retained in the POTW sludge. It can interfere with treatment processes in the POTW and can also limit the usefulness of municipal sludge.

In slug doses, and particularly in the presence of copper, dissolved zinc can interfere with or seriously disrupt the operation of POTW biological processes by reducing overall

removal efficiencies, largely as a result of the toxicity of the metal to biological organisms. However, zinc solids in the form of hydroxides or sulfides do not appear to interfere with biological treatment processes, on the basis of available data. Such solids accumulate in the sludge.

The influent concentrations of zinc to a POTW have been observed by the EPA to range from 0.017 to 3.91 mg/l, with a median concentration of 0.33 mg/l. Primary treatment is not efficient in removing zinc; however, the microbial floc of secondary treatment readily adsorbs zinc.

In a study of 258 POTW facilities, the median pass-through values were 70 to 88 percent for primary plants, 50 to 60 percent for trickling filter and biological process plants, and 30 to 40 percent for activated process plants. POTW effluent concentrations of zinc ranged from 0.003 to 3.6 mg/l (mean = 0.330, standard deviation = 0.464).

The zinc which does not pass through the POTW is retained in the sludge. The presence of zinc in sludge may limit its use on cropland. Sewage sludge contains 72 to over 30,000 mg/kg of zinc, with 3,366 mg/kg as the mean value. These concentrations are significantly greater than those normally found in soil, which range from 0 to 195 mg/kg, with 94 mg/kg being a common level. Therefore, application of sewage sludge to soil will generally increase the concentration of zinc in the soil. Zinc can be toxic to plants, depending upon soil pH. Lettuce, tomatoes, turnips, mustard, kale, and beets are especially sensitive to zinc contamination.

Oil and Grease. Oil and grease are taken together as one pollutant parameter. This is a conventional pollutant and some of its components are:

1. Light Hydrocarbons - These include light fuels such as gasoline, kerosene, and jet fuel, and miscellaneous solvents used for industrial processing, degreasing, or cleaning purposes. The presence of these light hydrocarbons may make the removal of other heavier oil wastes more difficult.

2. Heavy Hydrocarbons, Fuels, and Tars - These include the crude oils, diesel oils, #6 fuel oil, residual oils, slop oils, and in some cases, asphalt and road tar.

3. Lubricants and Cutting Fluids - These generally fall into two classes: non-emulsifiable oils such as lubricating oils and greases and emulsifiable oils such as water soluble oils, rolling oils, cutting oils, and drawing compounds. Emulsifiable oils may contain fat, soap, or various other additives.

4. Vegetable and Animal Fats and Oils - These originate primarily from processing of foods and natural products.

These compounds can settle or float and may exist as solids or

liquids depending upon factors such as method of use, production process, and temperature of water.

Oil and grease even in small quantities cause troublesome taste and odor problems. Scum lines from these agents are produced on water treatment basin walls and other containers. Fish and water fowl are adversely affected by oils in their habitat. Oil emulsions may adhere to the gills of fish causing suffocation, and the flesh of fish is tainted when microorganisms that were exposed to waste oil are eaten. Deposition of oil in the bottom sediments of water can serve to inhibit normal benthic growth. Oil and grease exhibit an oxygen demand.

Many of the toxic organic pollutants will be found distributed between the oil phase and the aqueous phase in industrial wastewaters. The presence of phenols, PCBs, PAHs, and almost any other organic pollutant in the oil and grease make characterization of this parameter almost impossible. However, all of these other organics add to the objectionable nature of the oil and grease.

Levels of oil and grease which are toxic to aquatic organisms vary greatly, depending on the type and the species susceptibility. However, it has been reported that crude oil in concentrations as low as 0.3 mg/l is extremely toxic to freshwater fish. It has been recommended that public water supply sources be essentially free from oil and grease.

Oil and grease in quantities of 100 l/sq km show up as a sheen on the surface of a body of water. The presence of oil slicks decreases the aesthetic value of a waterway.

Oil and grease is compatible with a POTW activated sludge process in limited quantity. However, slug loadings or high concentrations of oil and grease interfere with biological treatment processes. The oils coat surfaces and solid particles, preventing access of oxygen, and sealing in some microorganisms. Land spreading of POTW sludge containing oil and grease uncontaminated by toxic pollutants is not expected to affect crops grown on the treated land or animals eating those crops.

pH. Although not a specific pollutant, pH is related to the acidity or alkalinity of a wastewater stream. It is not, however, a measure of either. The term pH is used to describe the hydrogen ion concentration (or activity) present in a given solution. Values for pH range from 0 to 14, and these numbers are the negative logarithms of the hydrogen ion concentrations. A pH of 7 indicates neutrality. Solutions with a pH above 7 are alkaline, while those solutions with a pH below 7 are acidic. The relationship of pH and acidity and alkalinity is not necessarily linear or direct. Knowledge of the water pH is useful in determining necessary measures for corrosion control, sanitation, and disinfection. Its value is also necessary in the treatment of industrial wastewaters to determine amounts of chemicals required to remove pollutants and to measure their

effectiveness. Removal of pollutants, especially dissolved solids is affected by the pH of the wastewater.

Waters with a pH below 6.0 are corrosive to water works structures, distribution lines, and household plumbing fixtures and can thus add constituents to drinking water such as iron, copper, zinc, cadmium, and lead. The hydrogen ion concentration can affect the taste of the water, and at a low pH, water tastes sour. The bactericidal effect of chlorine is weakened as the pH increases, and it is advantageous to keep the pH close to 7.0. This is significant for providing safe drinking water.

Extremes of pH or rapid pH changes can exert stress conditions or kill aquatic life outright. Even moderate changes from acceptable criteria limits of pH are deleterious to some species.

The relative toxicity to aquatic life of many materials is increased by changes in the water pH. For example, metalocyanide complexes can increase a thousand-fold in toxicity with a drop of 1.5 pH units.

Because of the universal nature of pH and its effect on water quality and treatment, it is selected as a pollutant parameter for many industry categories. A neutral pH range (approximately 6 to 9) is generally desired because either extreme beyond this range has a deleterious effect on receiving waters or the pollutant nature of other wastewater constituents.

Pretreatment for regulation of pH is covered by the "General Pretreatment Regulations for Existing and New Sources of Pollution," 40 CFR 403.5. This section prohibits the discharge to a POTW of "pollutants which will cause corrosive structural damage to the POTW but in no case discharges with pH lower than 5.0 unless the works is specially designed to accommodate such discharges."

Total Suspended Solids (TSS). Suspended solids include both organic and inorganic materials. The inorganic compounds include sand, silt, and clay. The organic fraction includes such materials as grease, oil, tar, and animal and vegetable waste products. These solids may settle out rapidly, and bottom deposits are often a mixture of both organic and inorganic solids. Solids may be suspended in water for a time and then settle to the bed of the stream or lake. These solids discharged with man's wastes may be inert, slowly biodegradable materials, or rapidly decomposable substances. While in suspension, suspended solids increase the turbidity of the water, reduce light penetration, and impair the photosynthetic activity of aquatic plants.

Suspended solids in water interfere with many industrial processes and cause foaming in boilers and encrustations on equipment exposed to such water, especially as the temperature rises. They are undesirable in process water used in the manufacture of steel, in the textile industry, in laundries,

in dyeing, and in cooling systems.

Solids in suspension are aesthetically displeasing. When they settle to form sludge deposits on the stream or lake bed, they are often damaging to the life in the water. Solids, when transformed to sludge deposit, may do a variety of damaging things, including blanketing the stream or lake bed and thereby destroying the living spaces for those benthic organisms that would otherwise occupy the habitat. When of an organic nature, solids use a portion or all of the dissolved oxygen available in the area. Organic materials also serve as a food source for sludgeworms and associated organisms.

Disregarding any toxic effect attributable to substances leached out by water, suspended solids may kill fish and shellfish by causing abrasive injuries and by clogging the gills and respiratory passages of various aquatic fauna. Indirectly, suspended solids are inimical to aquatic life because they screen out light, and they promote and maintain the development of noxious conditions through oxygen depletion. This results in the killing of fish and fish food organisms. Suspended solids also reduce the recreational value of the water.

Total suspended solids is a traditional pollutant which is compatible with a well-run POTW. This pollutant, with the exception of those components which are described elsewhere in this section (e.g., heavy metal components), does not interfere with the operation of a POTW. However, since a considerable portion of the innocuous TSS may be inseparably bound to the constituents which do interfere with POTW operation, or produce unusable sludge, or subsequently dissolve to produce unacceptable POTW effluent, TSS may be considered a toxic waste.

Aluminum. Aluminum, a nonconventional pollutant, is the most common metallic element in the earth's crust, and the third most abundant element (8.1 percent). It is never found free in nature. Most rocks and various clays contain aluminum in the form of aluminosilicate minerals. Generally, aluminum is first converted to alumina (Al_2O_3) from bauxite ore. The alumina then undergoes electrolytic reduction to form the metal. Aluminum powders (used in explosives, fireworks, and rocket fuels) form flammable mixtures in the air. Aluminum metal resists corrosion under many conditions by forming a protective oxide film on the surface. This oxide layer corrodes rapidly in strong acids and alkalis, and by the electrolytic action of other metals with which it comes in contact. Aluminum is light, malleable, ductile, possesses high thermal and electrical conductivity, and is non-magnetic. It can be formed, machined, or cast. Aluminum is used in the building and construction, transportation, and the container and packaging industries and competes with iron and steel in these markets. Total U.S. production of primary aluminum in 1981 was 4,948,000 tons. Secondary aluminum (from scrap) production in 1981 was 886,000 tons.

Aluminum is soluble under both acidic and basic conditions, with environmental transport occurring most readily under these conditions. In water, aluminum can behave as an acid or base, can form ionic complexes with other substances, and can polymerize, depending on pH and the dissolved substances in water. Aluminum's high solubility at acidic pH conditions makes it readily available for accumulation in aquatic life. Acidic waters consistently contain higher levels of soluble aluminum than neutral or alkaline waters. Loss of aquatic life in acidified lakes and streams has been shown to be due in part to increased concentrations of aluminum in waters as a result of leaching of aluminum from soil by acidic rainfall.

Aluminum has been found to be toxic to freshwater and marine aquatic life. In freshwaters, acute toxicity and solubility increases as pH levels increase above pH 7. This relationship also appears to be true as the pH levels decrease below pH 7. Chronic effects of aluminum on aquatic life have also been documented. Aluminum has been found to be toxic to certain plants. A water quality standard for aluminum was established (U.S. Federal Water Pollution Control Administration, 1968) for interstate agricultural and irrigation waters, which set a trace element tolerance at 1 mg/l for continuous use on all soils and 20 mg/l for short-term use on fine-textured soils.

There are no reported adverse physiological effects on man from exposure to low concentrations of aluminum in drinking water. Large concentrations of aluminum in the human body, however, are alleged to cause changes in behavior. Aluminum compounds, especially aluminum sulfate, are major coagulants used in the treatment of drinking water. Aluminum is not among the metals for which a drinking water standard has been established.

The highest aluminum concentrations in animals and humans occur in the lungs, mostly from the inhalation of airborne particulate matter. Pulmonary fibrosis has been associated with the inhalation of very fine particles of aluminum flakes and powders among workers in the explosives and fireworks industries. An occupational exposure Threshold Limit Value (TLV) of 5 mg/m³ is recommended for pyro powders to prevent lung changes, and a time weighted average (TWA) of 10 mg/m³ is recommended for aluminum dust. High levels of aluminum have been found in the brains, muscles, and bones of patients with chronic renal failure who are being treated with aluminum hydroxide, and high brain levels of aluminum are found in those suffering from Alzheimers disease (presenile dementia) which manifests behavioral changes.

Aluminum and some of its compounds used in food preparation and as food additives are generally recognized as safe and are sanctioned by the Food and Drug Administration. No limits on aluminum content in food and beverage products have been established.

Aluminum has no adverse effects on POTW operation at concentrations normally encountered. The results of an EPA study

of 50 POTW revealed that 49 POTW contained aluminum with effluent concentrations ranging from less than 0.1 mg/l to 1.07 mg/l and with an average removal of 82 percent.

Ammonia. Ammonia (chemical formula NH_3) is a nonconventional pollutant. It is a colorless gas with a very pungent odor, detectable at concentrations of 20 ppm in air by the nose, and is very soluble in water (570 gm/l at 25°C). Ammonia is produced industrially in very large quantities (nearly 20 million tons annually in the U.S.). It is converted to ammonium compounds or shipped in the liquid form (it liquifies at -33°C). Ammonia also results from natural processes. Bacterial action on nitrates or nitrites, as well as dead plant and animal tissue and animal wastes produces ammonia. Typical domestic wastewaters contain 12 to 50 mg/l ammonia.

The principal use of ammonia and its compounds is as fertilizer. High amounts are introduced into soils and the water runoff from agricultural land by this use. Smaller quantities of ammonia are used as a refrigerant. Aqueous ammonia (2 to 5 percent solution) is widely used as a household cleaner. Ammonium compounds find a variety of uses in various industries; as an example, ammonium hydroxide is used as a reactant in the purification of tungsten.

Ammonia is toxic to humans by inhalation of the gas or ingestion of aqueous solutions. The ionized form, ammonium (NH_4^+), is less toxic than the un-ionized form. Ingestion of as little as one ounce of household ammonia has been reported as a fatal dose. Whether inhaled or ingested, ammonia acts destructively on mucous membrane with resulting loss of function. Aside from breaks in liquid ammonia refrigeration equipment, industrial hazard from ammonia exists where solutions of ammonium compounds may be accidentally treated with a strong alkali, releasing ammonia gas. As little as 150 ppm ammonia in air is reported to cause laryngeal spasms and inhalation of 5,000 ppm in air is considered sufficient to result in death.

The behavior of ammonia in POTW is well documented because it is a natural component of domestic wastewaters. Only very high concentrations of ammonia compounds could overload POTW. One study has shown that concentrations of un-ionized ammonia greater than 90 mg/l reduce gasification in anaerobic digesters and concentrations of 140 mg/l stop digestion completely. Corrosion of copper piping and excessive consumption of chlorine also result from high ammonia concentrations. Interference with aerobic nitrification processes can occur when large concentrations of ammonia suppress dissolved oxygen. Nitrites are then produced instead of nitrates. Elevated nitrite concentrations in drinking water are known to cause infant methemoglobinemia.

Cobalt. Cobalt is a nonconventional pollutant. It is a brittle, hard, magnetic, gray metal with a reddish tinge. Cobalt ores are usually the sulfide or arsenic [smaltite-(Co, Ni)As₂; cobaltite-CoAsS] and are sparingly distributed in the earth's crust.

Cobalt is usually produced as a by-product of mining copper, nickel, arsenic, iron, manganese, or silver. Because of the variety of ores and the very low concentrations of cobalt, recovery of the metal is accomplished by several different processes. Most consumption of cobalt is for alloys. Over two-thirds of U.S. production goes to heat-resistant, magnetic, and wear-resistant alloys. Chemicals and color pigments make up most of the rest of consumption.

Cobalt and many of its alloys are not corrosion resistant; therefore, minor corrosion of any of the tool alloys or electrical resistance alloys can contribute to its presence in raw wastewater from a variety of manufacturing facilities. Additionally, the use of cobalt soaps used in coatings may be a general source of small quantities of the metal. Several cobalt pigments are used in paints to produce yellows or blues.

Cobalt is an essential nutrient for humans and other mammals, and is present at a fairly constant level of about 1.2 mg in the adult human body. Mammals tolerate low levels of ingested water-soluble cobalt salts without any toxic symptoms; safe dosage levels in man have been stated to be 2-7 mg/kg body weight per day. A goitrogenic effect in humans is observed after the systematic administration of 3-4 mg cobalt as cobaltous chloride daily for three weeks. Fatal heart disease among heavy beer drinkers was attributed to the cardiotoxic action of cobalt salts which were formerly used as additives to improve foaming. The carcinogenicity of cobalt in rats has been verified; however, there is no evidence for the involvement of dietary cobalt in carcinogenesis in mammals.

There are no data available on the behavior of cobalt in POTW. There are no data to lead to an expectation of adverse effects of cobalt on POTW operation or the utility of sludge from POTW for crop application. Cobalt which enters POTW is expected to pass through to the effluent unless sufficient sulfide ion is present, or generated in anaerobic processes in the POTW to cause precipitation of the very insoluble cobalt sulfide.

Fluoride. Fluoride ion (F^-) is a nonconventional pollutant. Fluorine is an extremely reactive, pale yellow gas which is never found free in nature. Compounds of fluorine - fluorides - are found widely distributed in nature. The principal minerals containing fluorine are fluorspar (CaF_2) and cryolite (Na_2AlF_6). Although fluorine is produced commercially in small quantities by electrolysis of potassium bifluoride in anhydrous hydrogen fluoride, the elemental form bears little relation to the combined ion. Total production of fluoride chemicals in the U.S. is difficult to estimate because of the varied uses. Large volume usage compounds are: calcium fluoride (estimated 1,500,000 tons in U.S.) and sodium fluoraluminate (estimated 100,000 tons in U.S.). Some fluoride compounds and their uses are sodium fluoroaluminate - aluminum production; calcium fluoride - steelmaking, hydrofluoric acid production,

enamel, iron foundry; boron trifluoride - organic synthesis; antimony penta-fluoride - fluorocarbon production; fluoboric acid and fluobor-ates - electroplating; perchloryl fluoride (ClO_3F) - rocket fuel oxidizer; hydrogen fluoride - organic fluoride manufacture, pickling acid in stainless steelmaking manufacture of aluminum fluoride sulfur hexafluoride - insulator in high voltage trans-formers; polytetrafluoroethylene - inert plastic. Sodium fluoride is used at a concentration of about 1 mg/l in many public drinking water supplies to prevent tooth decay in children.

The toxic effects of fluoride on humans include severe gastroenteritis, vomiting, diarrhea, spasms, weakness, thirst, failing pulse and delayed blood coagulation. Most observations of toxic effects are made on individuals who intentionally or accidentally ingest sodium fluoride intended for use as rat poison or insecticide. Lethal doses for adults are estimated to be as low as 2.5 g. At 1.5 ppm in drinking water, mottling of tooth enamel is reported, and 14 ppm, consumed over a period of years, may lead to deposition of calcium fluoride in bone and tendons.

Fluorides found in irrigation waters in high concentrations have caused damage to certain plants exposed to these waters. Chronic fluoride poisoning of livestock has been observed. Fluoride from waters apparently does not accumulate in soft tissue to a significant degree; it is transferred to a very small extent into the milk and to a somewhat greater degree in eggs. Data for fresh water indicate that fluorides are toxic to fish.

Very few data are available on the behavior of fluoride in POTW. Under usual operating conditions in POTW, fluorides pass through into the effluent. Very little of the fluoride entering conventional primary and secondary treatment processes is removed. In one study of POTW influents conducted by the U.S. EPA, nine POTW reported concentrations of fluoride ranging from 0.7 mg/l to 1.2 mg/l, which is the range of concentrations used for fluoridated drinking water.

Iron. Iron is a nonconventional pollutant. It is an abundant metal found at many places in the earth's crust. The most common iron ore is hematite (Fe_2O_3) from which iron is obtained by reduction with carbon. Other forms of commercial ores are magnetite (Fe_3O_4) and taconite (FeSiO). Pure iron is not often found in commercial use, but it is usually alloyed with other metals and minerals. The most common of these is carbon.

Iron is the basic element in the production of steel. Iron with carbon is used for casting of major parts of machines and it can be machined, cast, formed, and welded. Ferrous iron is used in paints, while powdered iron can be sintered and used in powder metallurgy. Iron compounds are also used to precipitate other metals and undesirable minerals from industrial wastewater streams.

Corrosion products of iron in water cause staining of porcelain fixtures, and ferric iron combines with tannin to produce a dark violet color. The presence of excessive iron in water discourages cows from drinking and thus reduces milk production. High concentrations of ferric and ferrous ions in water kill most fish introduced to the solution within a few hours. The killing action is attributed to coatings of iron hydroxide precipitates on the gills. Iron oxidizing bacteria are dependent on iron in water for growth. These bacteria form slimes that can affect the aesthetic values of bodies of water and cause stoppage of flows in pipes. However, high concentrations of iron can precipitate on bottom sediments and affect rooted aquatic and invertebrate benthos.

Iron is an essential nutrient and micro-nutrient for all forms of growth. Drinking water standards in the U.S. set a limit of 0.3 mg/l of iron in domestic water supplies based on aesthetic and organoleptic properties of iron in water.

High concentrations of iron do not pass through a POTW into the effluent. In some POTW iron salts are added to coagulate precipitates and suspended sediments into a sludge. In an EPA study of POTW, the concentration of iron in the effluent of 22 biological POTW meeting secondary treatment performance levels ranged from 0.048 to 0.569 mg/l with a median value of 0.25 mg/l. This represented removals of 76 to 97 percent with a median of 87 percent removal.

Iron in sewage sludge spread on land used for agricultural purposes is not expected to have a detrimental effect on crops grown on the land.

Molybdenum. Molybdenum is present in the environment in trace quantities. It is estimated that 3.6×10^{10} grams of molybdenum are released into surface waters of the world each year by natural processes. Most surface waters contain less than 0.020 mg Mo/l, and sea water concentrations range from 0.004 to 0.012 mg Mo/l. Finished waters in the United States contain a median of 0.0014 mg Mo/l and a maximum of 0.068 mg Mo/l. Normal concentrations in stream sediments range from 1 to 5 ppm Mo, and the concentration of molybdenum tends to increase with decreasing grain size.

Molybdenum is vitally necessary to plants and animals as it is a constituent of essential enzymes needed for life processes. Molybdenum concentrations in plants normally range from 1 to 2 ppm, though a range of tenths to hundredths of ppm have been observed. Legumes tend to take up more molybdenum than other plants. Accumulation of molybdenum in plants occurs without detrimental effects.

Disease related to molybdenum in humans and animals has historically been a result of excessive uptake of molybdenum.

Average daily intake of molybdenum in the United States varies

between 0.120 and 0.240 mg Mo/day, depending on age, sex, and family income. Estimated daily intake of molybdenum in the U.S.S.R. has been reported to be between 0.329 and 0.376 mg Mo/day. Abnormally high intakes, as high as 10 to 15 mg Mo/day, have been documented in India, the U.S.S.R., and are suspected in Turkey. Diet plays a large part in determining molybdenum uptake. Legumes, cereal grains, leafy vegetables, liver, and kidney beans are among the foods which contain greater concentrations of molybdenum than fruits, root and stem vegetables, muscle meats, and dairy products.

The only clinical symptom resulting from excessive molybdenum uptake in humans is described as a gout-like disease. Study of a human population receiving 10 to 15 mg Mo/day found high incidence of this gout-like disease. In addition, increased uric acid levels were noted. Another study where humans were exposed to 10 mg Mo/day found greatly increased blood and urine levels of molybdenum, and significant increases in uric acid excretion, though the levels of uric acid were still within an acceptable range for humans. For daily intake levels between 0.5 and 1.0 mg Mo, increased urinary copper excretion was noted in human subjects. Increased urinary excretion of molybdenum has been observed in humans whose water supply contained 0.050 to 0.200 mg Mo/l. No biochemical or clinical effects are known in humans whose water supply contains less than 0.050 mg Mo/l.

Sources of molybdenum for animals are primarily in pasture forage and grain feed. Intake from water sources is not very significant. Molybdenum is more toxic to animals than to humans, and cattle and sheep are more susceptible to disease caused by excessive molybdenum than rats, poultry, horses, and pigs. These species differences are not understood. The Registry of Toxic Effects for Chemical Substances states the lower toxic dose (oral) for rats and rodents is 6.050 mg/kg.

All cattle are susceptible to molybdenosis, with dairy cattle and calves showing a higher susceptibility. The characteristic scouring disease and weight loss may be debilitating to the point of permanent injury or death. Pastures containing 20 to 100 ppm Mo (dry weight basis) are likely to induce the disease as compared to health forage containing 3 to 5 ppm molybdenum or less. It is difficult to assign a firm threshold value of molybdenum contained in pasture that will include molybdenosis because of the effects of two other dietary constituents. High levels of molybdenum act to decrease the retention of copper in an animal. Increased copper intake could, therefore, mitigate the effect of high amounts of molybdenum. The second factor in the diet is sulfate. It has been shown that in animals showing increasing levels of molybdenum, an increase in dietary sulfate causes more of the molybdenum to be excreted harmlessly.

A study of the effects on frogs to changes in the molybdenum concentration in the aqueous environment concluded that while high concentrations of aqueous molybdenum increased blood levels of molybdenum in frogs, no deleterious effects were observed.

Laboratory bioassays involving rainbow trout have also been conducted to determine long-term and acute toxicity of molybdenum. Long-term toxicity tests included sodium molybdate dissolved in demineralized water in concentrations ranging from 0 to 17 mg/l Mo. After one year, results showed no significant differences in growth and mortality for the exposed fish. Acute toxicity results determined that for rainbow trout averaging 55 mm and 20 mm, the 96 hr LC50 is 1,320 mg/l Mo and 800 mg/l Mo, respectively. Generally it was concluded that molybdenum as molybdate in the aquatic environment constitutes little danger to rainbow trout.

A third study was done to determine whether or not molybdenum mining in Colorado was causing any environmental problems to the natural wildlife in geographic areas impacted by molybdenum mining and milling. Animals in the area were assayed, fish were placed a mile downstream of mine tailings, and tailings were fed to chicks. No serious adverse effects were discovered in animals, and chicks fed 20 percent mine tailings remained healthy. Some adverse effects and abnormal tissue were found in the fish, but it was not certain whether these conditions were caused by excessive molybdenum or other heavy metals also present in the stream.

In conclusion, molybdenum is not very toxic to humans. Clinical effects have been reported at steady intake levels of 10 to 15 mg Mo/day, and biochemical effects in the range of 0.5 to 10 mg Mo/day. Below 0.5 mg Mo/day, there is no evidence of substantial toxic effects of molybdenum to humans.

The greatest problem of molybdenum toxicity involves cattle and other ruminants. These animals are for unknown reasons particularly susceptible to molybdenosis, and in addition, rely entirely on forage for food. It is known that plants can accumulate molybdenum without harmful effects but herbage containing more than 20 ppm Mo (dry weight basis) may cause molybdenosis in cattle.

High molybdenum content in surface waters in the United States is rare and usually associated with molybdenum mining and milling, uranium mining and milling, copper mining and milling, molybdenum smelting and purification, or shale oil production. Toxicity of molybdenum to some aquatic life has been shown to be low. Surface or ground waters high in molybdenum that are used for farmland irrigation may increase molybdenum content of plants. This may have effects on animals further along the food chain.

Phenols (Total). "Total Phenols" is a nonconventional pollutant parameter. Total phenols is the result of analysis using the 4-AAP (4-aminoantipyrene) method. This analytical procedure measures the color development of reaction products between 4-AAP and some phenols. The results are reported as phenol. Thus "total phenol" is not total phenols because many phenols (notably nitrophenols) do not react. Also, since each reacting phenol contributes to the color development to a different degree, and

each phenol has a molecular weight different from others and from phenol itself, analyses of several mixtures containing the same total concentration in mg/l of several phenols will give different numbers depending on the proportions in the particular mixture.

Despite these limitations of the analytical method, total phenols is a useful parameter when the mix of phenols is relatively constant and an inexpensive monitoring method is desired. In any given plant or even in an industry subcategory, monitoring of "total phenols" provides an indication of the concentration of this group of priority pollutants as well as those phenols not selected as priority pollutants. A further advantage is that the method is widely used in water quality determinations.

In an EPA survey of 103 POTW the concentration of "total phenols" ranged from 0.0001 mg/l to 0.176 mg/l in the influent, with a median concentration of 0.016 mg/l. Analysis of effluents from 22 of these same POTW which had biological treatment meeting secondary treatment performance levels showed "total phenols" concentrations ranging from 0 mg/l to 0.203 mg/l with a median of 0.007. Removals were 64 to 100 percent with a median of 78 percent.

It must be recognized, however, that six of the 11 priority pollutant phenols could be present in high concentrations and not be detected. Conversely, it is possible, but not probable, to have a high "total phenol" concentration without any phenol itself or any of the 10 other priority pollutant phenols present. A characterization of the phenol mixture to be monitored to establish constancy of composition will allow "total phenols" to be used with confidence.

Titanium. Titanium is a nonconventional pollutant. It is a lustrous white metal occurring as the oxide in ilmenite ($\text{FeO}\cdot\text{TiO}_2$) and rutile (TiO_2). The metal is used in heat-resistant, high-strength, light-weight alloys for aircraft and missiles. It is also used in surgical appliances because of its high strength and light weight. Titanium dioxide is used extensively as a white pigment in paints, ceramics, and plastics.

Toxicity data on titanium are not abundant. Because of the lack of definitive data, titanium compounds are generally considered non-toxic. Large oral doses of titanium dioxide (TiO_2) and thiotitanic acid (H_4TiSO_3) were tolerated by rabbits for several days with no toxic symptoms. However, impaired reproductive capacity was observed in rats fed 5 mg/l titanium as titanite in drinking water. There was also a reduction in the male/female ratio and in the number of animals surviving to the third generation. Titanium compounds are reported to inhibit several enzyme systems and to be carcinogenic.

The behavior of titanium in POTW has not been studied. On the basis of the insolubility of the titanium oxides in water, it is expected that most of the titanium entering the POTW will be

removed by settling and will remain in the sludge. No data were found regarding possible effects on plants as a result of spreading titanium-containing sludge on agricultural cropland.

SUMMARY OF POLLUTANT SELECTION

After examining the sampling data, pollutants and pollutant parameters were selected by subcategory for further consideration for limitation. The selection of a pollutant was based on the concentration of the pollutant in the raw sampling data and the frequency of occurrence above concentrations considered treatable. The pollutants selected under this rationale are listed in Table VI-2 (page 131). The analysis that led to the selection of these priority pollutants and the exclusion of pollutants is presented in Section VI of each subcategory supplement.

Table VI-1

LIST OF 129 PRIORITY POLLUTANTS

Compound Name

1. acenaphthene
2. acrolein
3. acrylonitrile
4. benzene
5. benzidene
6. carbon tetrachloride (tetrachloromethane)

Chlorinated benzenes (other than dichlorobenzenes)

7. chlorobenzene
8. 1,2,4-trichlorobenzene
9. hexachlorobenzene

Chlorinated ethanes (including 1,2-dichloroethane, 1,1,1-trichloroethane and hexachloroethane)

10. 1,2-dichloroethane
11. 1,1,1-trichloroethane
12. hexachloroethane
13. 1,1-dichloroethane
14. 1,1,2-trichloroethane
15. 1,1,2,2-tetrachloroethane
16. chloroethane

Chloroalkyl ethers (chloromethyl, chloroethyl and mixed ethers)

17. bis(chloromethyl) ether (deleted)
18. bis (2-chloroethyl) ether
19. 2-chloroethyl vinyl ether (mixed)

Chlorinated naphthalene

20. 2-chloronaphthalene

Chlorinated phenols (other than those listed elsewhere: includes trichlorophenols and chlorinated cresols)

21. 2,4,6-trichlorophenol
22. parachlorometa cresol
23. chloroform (trichloromethane)
24. 2-chlorophenol

Table VI-1 (Continued)

LIST OF 129 PRIORITY POLLUTANTS

Dichlorobenzenes

- 25. 1,2-dichlorobenzene
- 26. 1,3-dichlorobenzene
- 27. 1,4-dichlorobenzene

Dichlorobenzidine

- 28. 3,3'-dichlorobenzidine

Dichloroethylenes (1,1-dichloroethylene and 1,2-dichloroethylene)

- 29. 1,1-dichloroethylene
- 30. 1,2-trans-dichloroethylene
- 31. 2,4-dichlorophenol

Dichloropropane and dichloropropene

- 32. 1,2-dichloropropane
- 33. 1,2-dichloropropylene (1,3-dichloropropene)
- 34. 2,4-dimethylphenol

Dinitrotoluene

- 35. 2,4-dinitrotoluene
- 36. 2,6-dinitrotoluene
- 37. 1,2-diphenylhydrazine
- 38. ethylbenzene
- 39. fluoranthene

Haloethers (other than those listed elsewhere)

- 40. 4-chlorophenyl phenyl ether
- 41. 4-bromophenyl phenyl ether
- 42. bis(2-chloroisopropyl) ether
- 43. bis(2-chloroethoxy) methane

Halomethanes (other than those listed elsewhere)

- 44. methylene chloride (dichloromethane)
- 45. methyl chloride (chloromethane)
- 46. methyl bromide (bromomethane)

Table VI-1 (Continued)

LIST OF 129 PRIORITY POLLUTANTS

Halomethanes (Cont.)

47. bromoform (tribromomethane)
48. dichlorobromomethane
49. trichlorofluoromethane (deleted)
50. dichlorofluoromethane (deleted)
51. chlorodibromomethane
52. hexachlorobutadiene
53. hexachlorocyclopentadiene
54. isophorone
55. naphthalene
56. nitrobenzene

Nitrophenols (including 2,4-dinitrophenol and dinitrocresol)

57. 2-nitrophenol
58. 4-nitrophenol
59. 2,4-dinitrophenol
60. 4,6-dinitro-o-cresol

Nitrosamines

61. N-nitrosodimethylamine
62. N-nitrosodiphenylamine
63. N-nitrosodi-n-propylamine
64. pentachlorophenol
65. phenol

Phthalate esters

66. bis(2-ethylhexyl) phthalate
67. butyl benzyl phthalate
68. di-n-butyl phthalate
69. di-n-octyl phthalate
70. diethyl phthalate
71. dimethyl phthalate

Polynuclear aromatic hydrocarbons

72. benzo (a)anthracene (1,2-benzanthracene)
73. benzo (a)pyrene (3,4-benzopyrene)
74. 3,4-benzofluoranthene
75. benzo(k)fluoranthene (11,12-benzofluoranthene)

Table VI-1 (Continued)

LIST OF 129 PRIORITY POLLUTANT

Polynuclear aromatic hydrocarbons (Cont.)

76. chrysene
77. acenaphthylene
78. anthracene
79. benzo(ghi)perylene (1,11-benzoperylene)
80. fluorene
81. phenanthrene
82. dibenzo (a,h)anthracene (1,2,5,6-dibenzanthracene)
83. indeno (1,2,3-cd)pyrene (w,e,o-phenylenepyrene)
84. pyrene
85. tetrachloroethylene
86. toluene
87. trichloroethylene
88. vinyl chloride (chloroethylene)

Pesticides and metabolites

89. aldrin
90. dieldrin
91. chlordane (technical mixture and metabolites)

DDT and metabolites

92. 4,4'-DDT
93. 4,4'-DDE(p,p' DDX)
94. 4,4'-DDD(p,p TDE)

Polychlorinated biphenyls (PCB's)Endosulfan and metabolites

95. a-endosulfan-Alpha
96. b-endosulfan-Beta
97. endosulfan sulfate

Endrin and metabolites

98. endrin
99. endrin aldehyde

Heptachlor and metabolites

100. heptachlor
101. heptachlor epoxide

Table VI-1 (Continued)

LIST OF 129 PRIORITY POLLUTANTS

Hexachlorocyclohexane (all isomers)

- 102. a-BHC-Alpha
- 103. b-BHC-Beta
- 104. r-BHC (lindane)-Gamma
- 105. g-BHC-Delta
- 106. PCB-1242 (Arochlor 1242)
- 107. PCB-1254 (Arochlor 1254)
- 108. PCB-1221 (Arochlor 1221)
- 109. PCB-1232 (Arochlor 1232)
- 110. PCB-1248 (Arochlor 1248)
- 111. PCB-1260 (Arochlor 1260)
- 112. PCB-1016 (Arochlor 1016)

Other

- 113. toxaphene

Metals and Cyanide, and Asbestos

- 114. antimony
- 115. arsenic
- 116. asbestos (Fibrous)
- 117. beryllium
- 118. cadmium
- 119. chromium (Total)
- 120. copper
- 121. cyanide (Total)
- 122. lead
- 123. mercury
- 124. nickel
- 125. selenium
- 126. silver
- 127. thallium
- 128. zinc
- 129. 2,3,7,8-tetra chlorodibenzo-p-dioxin (TCDD)

TABLE VI-2

POLLUTANTS SELECTED FOR FURTHER CONSIDERATION BY SUBCATEGORY

Bauxite Refining

- 21. 2,4,6-trichlorophenol
- 24. 2-chlorophenol
- 31. 2,4-dichlorophenol
- 57. 2-nitrophenol
- 58. 4-nitrophenol
- 65. phenol
- phenols (4-AAP)
- pH

Primary Aluminum Smelting Subcategory

- 1. acenaphthene
- 39. fluoranthene
- 55. naphthalene
- 72. benzo(a)anthracene (1,2-benzanthracene)
- 73. benzo(a)pyrene
- 76. chrysene
- 78. anthracene (a)
- 79. benzo(ghi)perylene (1,11-benzoperylene)
- 80. fluorene
- 81. phenanthrene (a)
- 82. dibenzo(a,h)anthracene (1,2,5,6-dibenzanthracene)
- 84. pyrene
- 114. antimony
- 115. arsenic
- 116. asbestos (Fibrous)
- 118. cadmium
- 119. chromium (Total)
- 120. copper
- 121. cyanide (Total)
- 122. lead
- 124. nickel
- 125. selenium
- 128. zinc
- aluminum
- fluoride
- oil and grease
- TSS
- pH

(a) Reported together

TABLE VI-2 (Continued)

POLLUTANTS SELECTED FOR FURTHER CONSIDERATION BY SUBCATEGORY

Secondary Aluminum Subcategory

65. phenol
118. cadmium
122. lead
128. zinc
aluminum
ammonia (N)
total phenolics (by 4-AAP method)
oil and grease
TSS
pH

Primary Electrolytic Copper Refining Subcategory

115. arsenic
119. chromium (Total)
120. copper
122. lead
124. nickel
126. silver
128. zinc
TSS
pH

Primary Lead Subcategory

116. asbestos (Fibrous)
118. cadmium
122. lead
128. zinc
TSS
pH

Primary Zinc Subcategory

115. arsenic
116. asbestos (Fibrous)
118. cadmium
119. chromium (Total)
120. copper
122. lead
124. nickel
126. silver
128. zinc
TSS
pH

TABLE VI-2 (Continued)

POLLUTANTS SELECTED FOR FURTHER CONSIDERATION BY SUBCATEGORY

Metallurgical Acid Plants

114. antimony
115. arsenic
118. cadmium
119. chromium
120. copper
122. lead
123. mercury
124. nickel
125. selenium
126. silver
128. zinc
fluoride
molybdenum
total suspended solids (TSS)
pH

Primary Tungsten Subcategory

11. 1,1,1-trichloroethane
55. naphthalene
65. phenol
73. benzo(a)pyrene
79. benzo(ghi)perylene
82. dibenzo(a,h)anthracene
85. tetrachloroethylene
86. toluene
118. cadmium
119. chromium (Total)
122. lead
124. nickel
126. silver
127. thallium
128. zinc
ammonia (N)
TSS
pH

TABLE VI-2 (Continued)

POLLUTANTS SELECTED FOR FURTHER CONSIDERATION BY SUBCATEGORY

Primary Columbium-Tantalum Subcategory

- 4. benzene
- 6. carbon tetrachloride
- 7. chlorobenzene
- 8. 1,2,4-trichlorobenzene
- 10. 1,2-dichloroethane
- 30. 1,2-trans-dichloroethylene
- 38. ethylbenzene
- 51. chlorodibromomethane
- 85. tetrachloroethylene
- 87. trichloroethylene
- 114. antimony
- 115. arsenic
- 116. asbestos (Fibrous)
- 118. cadmium
- 119. chromium (Total)
- 120. copper
- 122. lead
- 124. nickel
- 125. selenium
- 127. thallium
- 128. zinc
- ammonia (N)
- fluoride
- TSS
- pH

TABLE VI-2 (Continued)

POLLUTANTS SELECTED FOR FURTHER CONSIDERATION BY SUBCATEGORY

Secondary Silver Subcategory

- 4. benzene
- 6. carbon tetrachloride (tetrachloromethane)
- 10. 1,2-dichloroethane
- 11. 1,1,1-trichloroethane
- 29. 1,1-dichloroethylene
- 30. 1,2-trans-dichloroethylene
- 38. ethylbenzene
- 84. pyrene
- 85. tetrachloroethylene
- 86. toluene
- 87. trichloroethylene
- 114. antimony
- 115. arsenic
- 118. cadmium
- 119. chromium (Total)
- 120. copper
- 121. cyanide
- 122. lead
- 124. nickel
- 125. selenium
- 126. silver
- 127. thallium
- 128. zinc
- ammonia (N)
- total phenolics (by 4-AAP method)
- TSS
- pH

Secondary Lead Subcategory

- 114. antimony
- 115. arsenic
- 118. cadmium
- 119. chromium (Total)
- 120. copper
- 122. lead
- 124. nickel
- 126. silver
- 127. thallium
- 128. zinc
- ammonia
- TSS
- pH

TABLE VI-2 (Continued)

POLLUTANTS SELECTED FOR FURTHER CONSIDERATION BY SUBCATEGORY

Primary Antimony Subcategory

114. antimony
115. arsenic
118. cadmium
120. copper
122. lead
123. mercury
128. zinc
total suspended solids (TSS)
pH

Primary Beryllium

117. beryllium
119. chromium
120. copper
121. cyanide
ammonia (as N)
fluoride
total suspended solids (TSS)
pH

Primary and Secondary Germanium and Gallium

114. antimony
115. arsenic
118. cadmium
119. chromium
120. copper
122. lead
124. nickel
125. selenium
126. silver
127. thallium
128. zinc
fluoride
germanium
gallium
total suspended solids (TSS)
pH

TABLE VI-2 (Continued)

POLLUTANTS SELECTED FOR FURTHER CONSIDERATION BY SUBCATEGORY

Secondary Indium

118. cadmium
119. chromium
122. lead
124. nickel
125. selenium
126. silver
127. thallium
128. zinc
 indium
 total suspended solids (TSS)
 pH

Secondary Mercury

122. lead
123. mercury
127. thallium
128. zinc
 total suspended solids (TSS)
 pH

Primary Molybdenum and Rhenium

115. arsenic
119. chromium (total)
120. copper
122. lead
124. nickel
125. selenium
128. zinc
 ammonia (as N)
 fluoride
 molybdenum
 rhenium
 total suspended solids (TSS)
 pH

TABLE VI-2 (Continued)

POLLUTANTS SELECTED FOR FURTHER CONSIDERATION BY SUBCATEGORY

Secondary Molybdenum and Vanadium

115. arsenic
119. chromium
120. copper
122. lead
124. nickel
128. zinc
aluminum
ammonia (as N)
boron
cobalt
germanium
iron
manganese
molybdenum
tin
titanium
vanadium
total suspended solids
pH

Primary Nickel and Cobalt

120. copper
124. nickel
128. zinc
cobalt
ammonia (as N)
total suspended solids (TSS)
pH

Secondary Nickel

115. arsenic
119. chromium
120. copper
124. nickel
128. zinc
total suspended solids (TSS)
pH

TABLE VI-2 (Continued)

POLLUTANTS SELECTED FOR FURTHER CONSIDERATION BY SUBCATEGORY

Primary Precious Metals and Mercury

115. arsenic
118. cadmium
119. chromium
120. copper
122. lead
123. mercury
124. nickel
126. silver
127. thallium
128. zinc
gold
oil and grease
total suspended solids (TSS)
pH

Secondary Precious Metals

114. antimony
115. arsenic
118. cadmium
119. chromium
120. copper
121. cyanide
122. lead
124. nickel
125. selenium
126. silver
127. thallium
128. zinc
ammonia (as N)
gold
palladium
platinum
total suspended solids (TSS)
pH

TABLE VI-2 (Continued)

POLLUTANTS SELECTED FOR FURTHER CONSIDERATION BY SUBCATEGORY

Primary Rare Earth Metals

- 4. benzene
- 9. hexachlorobenzene
- 115. arsenic
- 118. cadmium
- 119. chromium (total)
- 120. copper
- 122. lead
- 124. nickel
- 125. selenium
- 126. silver
- 127. thallium
- 128. zinc
- total suspended solids (TSS)
- pH

Secondary Tantalum

- 114. antimony
- 120. copper
- 122. lead
- 124. nickel
- 126. silver
- 128. zinc
- tantalum
- total suspended solids (TSS)
- pH

TABLE VI-2 (Continued)

POLLUTANTS SELECTED FOR FURTHER CONSIDERATION BY SUBCATEGORY

Secondary Tin

114. antimony
115. arsenic
118. cadmium
119. chromium
120. copper
121. cyanide
122. lead
124. nickel
125. selenium
126. silver
127. thallium
128. zinc
aluminum
barium
boron
fluoride
iron
manganese
tin
total suspended solids (TSS)
pH

Primary and Secondary Titanium

114. antimony
118. cadmium
119. chromium (total)
120. copper
122. lead
124. nickel
127. thallium
128. zinc
titanium
oil and grease
total suspended solids (TSS)
pH

TABLE VI-2 (Continued)

POLLUTANTS SELECTED FOR FURTHER CONSIDERATION BY SUBCATEGORY

Secondary Tungsten and Cobalt

115. arsenic
118. cadmium
119. chromium
120. copper
122. lead
124. nickel
126. silver
128. zinc
 ammonia (as N)
 cobalt
 tungsten
 oil and grease
 total suspended solids (TSS)
 pH

Secondary Uranium

114. antimony
115. arsenic
118. cadmium
119. chromium (total)
120. copper
122. lead
124. nickel
125. selenium
126. silver
128. zinc
 fluoride
 uranium
 total suspended solids (TSS)
 pH

Primary Zirconium and Hafnium

118. cadmium
119. chromium (total)
121. cyanide (total)
122. lead
124. nickel
127. thallium
128. zinc
 ammonia (as N)
 hafnium
 radium-226
 zirconium
 total suspended solids (TSS)
 pH

FIGURE VI-3

POLYNUCLEAR AROMATIC HYDROCARBONS
(Toxic Pollutant No's 72 - 84)





72	Benzo(a)anthracene (1,2-benzanthracene)		m.p. 162°C
73	Benzo(a)pyrene (3,4-benzopyrene)		m.p. 176°C
74	3,4-Benzofluoranthene		m.p. 168°C
75	Benzo(k)fluoranthene (11,12-benzofluoranthene)		m.p. 217°C
76	Chrysene (1,2-benzphenanthrene)		m.p. 255°C
77	Acenaphthylene		m.p. 92°C
78	Anthracene		m.p. 216°C
79	Benzo(ghi)perylene (1,12-benzoperylene)		m.p. not reported
80	Fluorene (alpha-diphenylenemethane)		m.p. 116°C
81	Phenanthrene		m.p. 101°C

FIGURE VI-3 (Continued)

POLYNUCLEAR AROMATIC HYDROCARBONS
(Toxic Pollutant No's 72 - 84)

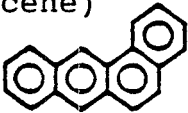
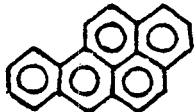
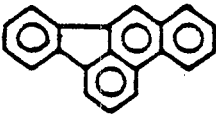
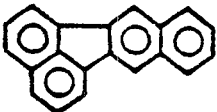
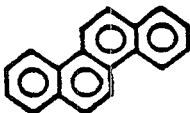
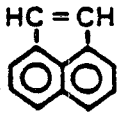
82 Dibenzo(a,h)anthracene
(1,2,5,6-dibenzoanthracene)

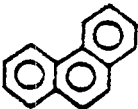
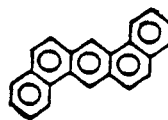

m.p. 269°C

83 Indeno (1,2,3-cd)pyrene
(2,3-o-phenylenepyrene)

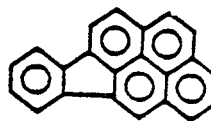

m.p. not available

84 Pyrene

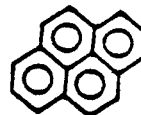

m.p. 156°C

FIGURE VI-3

POLYNUCLEAR AROMATIC HYDROCARBONS
(Toxic Pollutant No's 72 - 84)







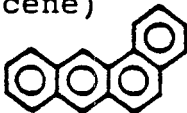
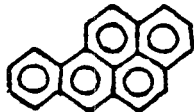

72	Benzo(a)anthracene (1,2-benzanthracene)		m.p. 162°C
73	Benzo(a)pyrene (3,4-benzopyrene)		m.p. 176°C
74	3,4-Benzofluoranthene		m.p. 168°C
75	Benzo(k)fluoranthene (11,12-benzofluoranthene)		m.p. 217°C
76	Chrysene (1,2-benzphenanthrene)		m.p. 255°C
77	Acenaphthylene		m.p. 92°C
78	Anthracene		m.p. 216°C
79	Benzo(ghi)perylene (1,12-benzoperylene)		m.p. not reported
80	Fluorene (alpha-diphenylenemethane)		m.p. 116°C
81	Phenanthrene		m.p. 101°C

FIGURE VI-3 (Continued)

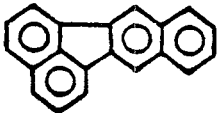
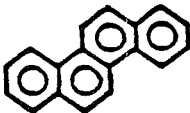
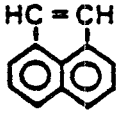
POLYNUCLEAR AROMATIC HYDROCARBONS
(Toxic Pollutant No's 72 - 84)

- | | | | |
|----|---|--|--------------------|
| 82 | Dibenzo(a,h)anthracene
(1,2,5,6-dibenzoanthracene) |  | m.p. 269°C |
| 83 | Indeno (1,2,3-cd)pyrene
(2,3-o-phenylenepyrene) |  | m.p. not available |
| 84 | Pyrene |  | m.p. 156°C |

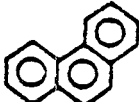
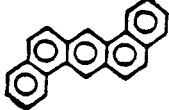
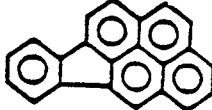
NONFERROUS METALS MANUFACTURING

SECTION VII

CONTROL AND TREATMENT TECHNOLOGY

This section describes the treatment techniques currently used or available to remove or recover wastewater pollutants normally generated by the nonferrous metals manufacturing industrial point source category. Included are discussions of individual end-of-pipe treatment technologies and in-plant technologies. These treatment technologies are widely used in many industrial categories, and data and information to support their effectiveness has been drawn from a similarly wide range of sources and data bases.

END-OF-PIPE TREATMENT TECHNOLOGIES

Individual recovery and treatment technologies are described which are used or are suitable for use in treating wastewater discharges from nonferrous metals manufacturing plants. Each description includes a functional description and discussion of application and performance, advantages and limitations, operational factors (reliability, maintainability, solid waste aspects), and demonstration status. The treatment processes described include both technologies presently demonstrated within the nonferrous metals manufacturing category, and technologies demonstrated in treatment of similar wastes in other industries.

Nonferrous metals manufacturing wastewaters characteristically may contain treatable concentrations of toxic metals. The toxic metals antimony, arsenic, beryllium, cadmium, chromium, copper, lead, mercury, nickel, selenium, silver, thallium and zinc are found in nonferrous metals manufacturing wastewater streams at treatable concentrations; and are generally free from strong chelating agents. Aluminum, ammonia, barium, boron, cesium, cobalt, columbium, cyanide, fluoride, gallium, germanium, gold, hafnium, indium, iron, manganese, molybdenum, palladium, phosphorus, platinum, radium-226, rhenium, rubidium, tantalum, tin, titanium, tungsten, uranium, vanadium, zirconium and some toxic organics (polynuclear aromatic hydrocarbons and phenols) also may be present. The toxic inorganic pollutants constitute the most significant wastewater pollutants in this category.

In general, these pollutants are removed by chemical precipitation and sedimentation or filtration. Most of them may be effectively removed by precipitation of metal hydroxides or carbonates utilizing the reaction with lime, sodium hydroxide, or sodium carbonate. For some, improved removals are provided by the use of sodium sulfide or ferrous sulfide to precipitate the pollutants as sulfide compounds with very low solubilities.

Discussion of end-of-pipe treatment technologies is divided into three parts: the major technologies; treatment effectiveness of major technologies; and minor technologies.

MAJOR TECHNOLOGIES

In Sections IX, X, XI, and XII the rationale for selecting model treatment systems is discussed. The individual technologies used in the system are described here. The major end-of-pipe technologies for treating nonferrous metals manufacturing wastewaters are: (1) chemical reduction of chromium, (2) chemical precipitation, (3) cyanide precipitation, (4) granular bed filtration, (5) pressure filtration, (6) settling, and (7) skimming. In practice, precipitation of metals and settling of the resulting precipitates is often a unified two-step operation. Suspended solids originally present in raw wastewaters are not appreciably affected by the precipitation operation and are removed with the precipitated metals in the settling operations. Settling operations can be evaluated independently of hydroxide or other chemical precipitation operations, but hydroxide and other chemical precipitation operations can only be evaluated in combination with a solids removal operation.

1. Chemical Reduction of Chromium

Description of the Process. Reduction is a chemical reaction in which electrons are transferred to the chemical being reduced from the chemical initiating the transfer (the reducing agent). Sulfur dioxide, sodium bisulfite, sodium metabisulfite, and ferrous sulfate form strong reducing agents in aqueous solution and are often used in industrial waste treatment facilities for the reduction of hexavalent chromium to the trivalent form. The reduction allows removal of chromium from solution in conjunction with other metallic salts by alkaline precipitation. Hexavalent chromium is not precipitated as the hydroxide.

Gaseous sulfur dioxide is a widely used reducing agent and provides a good example of the chemical reduction process. Reduction using other reagents is chemically similar. The reactions involved may be illustrated as follows:

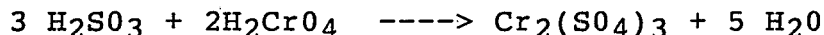

The above reaction is favored by low pH. A pH of from 2 to 3 is normal for situations requiring complete reduction. At pH levels above 5, the reduction rate is slow. Oxidizing agents such as dissolved oxygen and ferric iron interfere with the reduction process by consuming the reducing agent.

A typical treatment consists of 45 minutes retention in a reaction tank. The reaction tank has an electronic recorder-

controller device to control process conditions with respect to pH and oxidation reduction potential (ORP). Gaseous sulfur dioxide is metered to the reaction tank to maintain the ORP within the range of 250 to 300 millivolts. Sulfuric acid is added to maintain a pH level of from 1.8 to 2.0. The reaction tank is equipped with a propeller agitator designed to provide approximately one turnover per minute. Figure VII-13 (Page 266) shows a continuous chromium reduction system.

Application and Performance. Chromium reduction is most usually required to treat electroplating and metal surfacing rinse waters, but may also be required in nonferrous metals manufacturing plants. A study of an operational waste treatment facility chemically reducing hexavalent chromium has shown that a 99.7 percent reduction efficiency is easily achieved. Final concentrations of 0.05 mg/l are readily attained, and concentrations of 0.01 mg/l are considered to be attainable by properly maintained and operated equipment.

Advantages and Limitations. The major advantage of chemical reduction to reduce hexavalent chromium is that it is a fully proven technology based on many years of experience. Operation at ambient conditions results in minimal energy consumption, and the process, especially when using sulfur dioxide, is well suited to automatic control. Furthermore, the equipment is readily obtainable from many suppliers, and operation is straightforward.

One limitation of chemical reduction of hexavalent chromium is that for high concentrations of chromium, the cost of treatment chemicals may be prohibitive. When this situation occurs, other treatment techniques are likely to be more economical. Chemical interference by oxidizing agents is possible in the treatment of mixed wastes, and the treatment itself may introduce pollutants if not properly controlled. Storage and handling of sulfur dioxide is somewhat hazardous.

Operational Factors. Reliability: Maintenance consists of periodic removal of sludge; the frequency of removal depends on the input concentrations of detrimental constituents.

Solid Waste Aspects: Pretreatment to eliminate substances which will interfere with the process may often be necessary. This process produces trivalent chromium which can be controlled by further treatment. However, small amounts of sludge may be collected as the result of minor shifts in the solubility of the contaminants. This sludge can be processed by the main sludge treatment equipment.

Demonstration Status. The reduction of chromium waste by sulfur dioxide or sodium bisulfite is a classic process and is used by numerous plants which have hexavalent chromium compounds in wastewaters from operations such as electroplating, conversion coating and noncontact cooling.

2. Chemical Precipitation

Dissolved toxic metal ions and certain anions may be chemically precipitated for removal by physical means such as sedimentation, filtration, or centrifugation. Several reagents are commonly used to effect this precipitation:

1) Alkaline compounds such as lime or sodium hydroxide may be used to precipitate many toxic metal ions as metal hydroxides. Lime also may precipitate phosphates as insoluble calcium phosphate, fluorides as calcium fluoride and arsenic as calcium arsenate.

2) Both "soluble" sulfides such as hydrogen sulfide or sodium sulfide and "insoluble" sulfides such as ferrous sulfide may be used to precipitate many heavy metal ions as metal sulfides.

3) Ferrous sulfate, zinc sulfate or both (as is required) may be used to precipitate cyanide as a ferro or zinc ferricyanide complex.

4) Carbonate precipitates may be used to remove metals either by direct precipitation using a carbonate reagent such as calcium carbonate or by converting hydroxides into carbonates using carbon dioxide.

These treatment chemicals may be added to a flash mixer or rapid mix tank, to a presettling tank, or directly to a clarifier or other settling device. Because metal hydroxides tend to be colloidal in nature, coagulating agents may also be added to facilitate settling. After the solids have been removed, final pH adjustment may be required to reduce the high pH created by the alkaline treatment chemicals.

Chemical precipitation as a mechanism for removing metals from wastewater is a complex process of at least two steps -- precipitation of the unwanted metals and removal of the precipitate. Some very small amount of metal will remain dissolved in the wastewater after precipitation is complete. The amount of residual dissolved metal depends on the treatment chemicals used and related factors. The effectiveness of this method of removing any specific metal depends on the fraction of the specific metal in the raw waste (and hence in the precipitate) and the effectiveness of suspended solids removal. In specific instances, a sacrificial ion such as iron or aluminum may be added to aid in the removal of toxic metals by co-precipitation process and reduce the fraction of a specific metal in the precipitate.

Application and Performance. Chemical precipitation is used in nonferrous metals manufacturing for precipitation of dissolved metals. It can be used to remove metal ions such as aluminum, antimony, arsenic, beryllium, cadmium, chromium, copper, lead, mercury, nickel, zinc, cobalt, iron, manganese, tungsten, molybdenum and tin. The process is also applicable to any

substance that can be transformed into an insoluble form such as fluorides, phosphates, soaps, sulfides and others. Because it is simple and effective, chemical precipitation is extensively used for industrial waste treatment.

The performance of chemical precipitation depends on several variables. The more important factors affecting precipitation effectiveness are:

1. Maintenance of an appropriate (usually alkaline) pH throughout the precipitation reaction and subsequent settling;
2. Addition of a sufficient excess of treatment ions to drive the precipitation reaction to completion;
3. Addition of an adequate supply of sacrificial ions (such as iron or aluminum) to ensure precipitation and removal of specific target ions; and
4. Effective removal of precipitated solids (see appropriate solids removal technologies).

Control of pH. Irrespective of the solids removal technology employed, proper control of pH is absolutely essential for favorable performance of precipitation-sedimentation technologies. This is clearly illustrated by solubility curves for selected metals hydroxides and sulfides shown in Figure VII-1, (page 254), and by plotting effluent zinc concentrations against pH as shown in Figure VII-2 (page 255). Figure VII-2 was obtained from Development Document for the Proposed Effluent Limitations Guidelines and New Source Performance Standards for the Zinc Segment of Nonferrous Metals Manufacturing Point Source Category, U.S. E.P.A., EPA 440/1-74/033, November, 1974. Figure VII-2 was plotted from the sampling data from several facilities with metal finishing operations. It is partially illustrated by data obtained from 3 consecutive days of sampling at one metal processing plant (47432) as displayed in Table VII-1 (page 235). Flow through this system is approximately 49,263 l/h (13,000 gal/hr).

This treatment system uses lime precipitation (pH adjustment) followed by coagulant addition and sedimentation. Samples were taken before (in) and after (out) the treatment system. The best treatment for removal of copper and zinc was achieved on day one, when the pH was maintained at a satisfactory level. The poorest treatment was found on the second day, when the pH slipped to an unacceptably low level; intermediate values were achieved on the third day, when pH values were less than desirable but in between those for the first and second days.

Sodium hydroxide is used by one facility (plant 439) for pH adjustment and chemical precipitation, followed by settling (sedimentation and a polishing lagoon) of precipitated solids. Samples were taken prior to caustic addition and following the polishing lagoon. Flow through the system is approximately

22,700 l/hr. (6,000 gal/hr). These data displayed in Table VII-2 (page 235) indicate that the system was operated efficiently. Effluent pH was controlled within the range of 8.6 to 9.3, and, while raw waste loadings were not unusually high, most toxic metals were removed to very low concentrations.

Lime and sodium hydroxide (combined) are sometimes used to precipitate metals. Data developed from plant 40063, a facility with a metal bearing wastewater, exemplify efficient operation of a chemical precipitation and settling system. Table VII-3 (page 236) shows sampling data from this system, which uses lime and sodium hydroxide for pH adjustment and chemical precipitation, polyelectrolyte flocculant addition, and sedimentation. Samples were taken of the raw waste influent to the system and of the clarifier effluent. Flow through the system is approximately 19,000 l/hr (5,000 gal/hr).

At this plant, effluent TSS levels were below 15 mg/l on each day, despite average raw waste TSS concentrations of over 3500 mg/l. Effluent pH was maintained at approximately 8, lime addition was sufficient to precipitate the dissolved metal ions, and the flocculant addition and clarifier retention served to remove effectively the precipitated solids.

Sulfide precipitation is sometimes used to precipitate metals resulting in improved metals removals. Most metal sulfides are less soluble than hydroxides, and the precipitates are frequently more dependably removed from water. Solubilities for selected metal hydroxide, carbonate and sulfide precipitates are shown in Table VII-4, (page 236). (Source: Lange's Handbook of Chemistry). Sulfide precipitation is particularly effective in removing specific metals such as silver and mercury. Sampling data from three industrial plants using sulfide precipitation appear in Table VII-5 (page 237). In all cases except iron, effluent concentrations are below 0.1 mg/l and in many cases below 0.01 mg/l for the three plants studied.

Sampling data from several chlorine-caustic manufacturing plants using sulfide precipitation demonstrate effluent mercury concentrations varying between 0.009 and 0.03 mg/l. As shown in Figure VII-1 (page 254), the solubilities of PbS and Ag₂S are lower at alkaline pH levels than either the corresponding hydroxides or other sulfide compounds. This implies that removal performance for lead and silver sulfides should be comparable to or better than that for the metal hydroxides. Bench-scale tests on several types of metal finishing and manufacturing wastewater indicate that metals removal to levels of less than 0.05 mg/l and in some cases less than 0.01 mg/l are common in systems using sulfide precipitation followed by clarification. Some of the bench-scale data, particularly in the case of lead, do not support such low effluent concentrations. However, lead is consistently removed to very low levels (less than 0.02 mg/l) in systems using hydroxide and carbonate precipitation and sedimentation.

Of particular interest is the ability of sulfide to precipitate hexavalent chromium (Cr^{+6}) without prior reduction to the trivalent state as is required in the hydroxide process. When ferrous sulfide is used as the precipitant, iron and sulfide act as reducing agents for the hexavalent chromium according to the reaction:

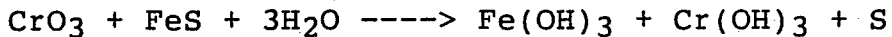

The sludge produced in this reaction consists mainly of ferric hydroxides, chromic hydroxides, and various metallic sulfides. Some excess hydroxyl ions are generated in this process, possibly requiring a downward re-adjustment of pH.

Based on the available data, Table VII-6 (page 238) shows the minimum reliably attainable effluent concentrations for sulfide precipitation-sedimentation systems. These values are used to calculate performance predictions of sulfide precipitation-sedimentation systems.

Sulfide precipitation is used in many process and wastewater treatment applications in nonferrous metals manufacturing. This technology is used to treat process wastewater discharges from cadmium recovery and to recover metals from zinc baghouse dusts at a U.S. nonferrous metals manufacturing plant. Another plant achieves complete recycle of electrolyte from copper refining through removal of metal impurities via sulfide precipitation. Primary tungsten is frequently separated from molybdenum via sulfide precipitation. In secondary tin production, lead is recovered from alkaline detinning solutions with sulfide precipitation just prior to electrowinning. In the production of beryllium hydroxide, sulfide precipitation is used to remove metal impurities prior to precipitating beryllium hydroxide. These demonstrations show that sulfide precipitation is in use in the nonferrous metals manufacturing category that may present equal or greater treatment difficulties as wastewater.

Sulfide precipitation also is used as a preliminary or polishing treatment technology for nonferrous metals manufacturing wastewater. A U.S. nonferrous metals manufacturing facility specifically uses sulfide precipitation operated at a low pH to remove specific toxic metals from the acid plant blowdown prior to discharging the wastewater to a lime and settle treatment system. Hydrogen sulfide is used to precipitate selenium. Arsenic is also precipitated as arsenic sulfide. The arsenic and selenium sulfides are removed in a plate and frame filter. EPA sampling at this plant found three-day averages of arsenic and selenium in the untreated acid plant blowdown of 4.74 mg/l and 21.5 mg/l of arsenic and selenium, respectively. Composite samples of treated (sulfide precipitation and filtration) acid plant blowdown collected during the EPA sampling visit showed arsenic concentrations at 0.066, 0.348 and 0.472 mg/l. Likewise, the treated acid plant blowdown samples contained selenium concentrations at 0.015, 0.05, and 0.132 mg/l.

Performance data collected by personnel at this same plant over a one-year time period (24 data points) indicate the long-term arithmetic mean for arsenic is 1.2 mg/l. Selenium data gathered at the same plant over one year (33 data points) show a long-term arithmetic mean of 0.53 mg/l. The effluent data submitted to the Agency are quite variable due to the methods used to control reagent addition by the plant. In fact, there is almost as much variability in the treated effluent from the filter press as there is in the raw acid plant blowdown. This is not characteristic of the well-operated treatment systems where a significant reduction in variability of raw waste loads is observed. Hydrogen sulfide is added to the acid plant blowdown based on flow rate, not influent concentration. EPA sampling data demonstrate that slight increases in influent arsenic concentration also produce similar increases in effluent arsenic concentrations. This is characteristic of a system in which treatment reagents are not being added in sufficient quantities. The Agency believes more uniform performance would be achieved if sulfide addition were properly controlled using a specific ion electrode. This method of control is demonstrated in sulfide treatment to recover silver from photographic solutions. In this way, excess sulfide is consistently added to ensure proper precipitation of arsenic and selenium sulfides.

While the average for arsenic from this plant is 1.2 mg/l, the system as operated was able to achieve concentrations as low as 0.04 mg/l. Likewise, for selenium, concentrations as low as 0.01 mg/l were achieved. The Agency recognizes that it is unlikely that plants could consistently achieve 0.04 mg/l and 0.01 mg/l, respectively; however, this performance indicates that through proper control of reagent addition the plant would vastly improve the performance.

Data are also available from a Swedish copper and lead smelter that operates a full-scale sulfide precipitation and hydroxide precipitation unit on acid plant blowdown, storm water, and facility cleaning wastewaters. The full-scale sulfide-hydroxide precipitation plant was started up in May 1978 and has operated since that time. The plant personnel compared hydroxide and sulfide precipitation for removal of toxic metals at the bench scale prior to design of the full-scale plant. On the basis of laboratory data, they determined that a combined sulfide-hydroxide process would be best. This approach resulted in the best overall removals and yielded a sludge that could be recycled into the smelting process.

This Swedish plant operates the sulfide precipitation portion of the process at a pH in the range of 3 to 5 standard units. This results in good copper, lead, and zinc removals as well as some reduction of arsenic and selenium. This mode of operation was selected to yield a sludge containing copper and lead sulfides that could be reintroduced readily into the smelter furnaces. Arsenic concentrations as low as 1.9 mg/l were achieved even in

this mode which is not optimized for arsenic removal.

There is a Japanese copper smelter with a metallurgical acid plant that operates a sulfide precipitation and filtration preliminary treatment system. The plant uses sulfide to treat acid plant blowdown containing arsenic concentrations of 8,530 mg/l, copper at 120 mg/l, lead at 30 mg/l, copper at 120 mg/l, lead at 30 mg/l and cadmium at 60 mg/l. The filtrate from this treatment system typically contains concentrations of 0.03 mg/l for arsenic, 0.03 mg/l for copper, 0.5 mg/l for lead and 0.3 mg/l for cadmium. Wastewater from the acid plant is pumped from the acid plant to a 50-cubic-meter stirred reaction tank where sodium hydrosulfide is added. Completion of the precipitation reaction is measured by a oxidation-reduction potentiometer. After the reaction is complete the wastewater is pumped to a filter press to separate the precipitated solids from solution. The filtrate is pumped for additional wastewater treatment downstream.

EPA also conducted bench-scale tests to determine the effectiveness of sulfide precipitation on metallurgical acid plant discharges. Wastewater samples were collected from a U.S. copper smelter and refinery with a metallurgical acid plant on site. The U.S. plant did not have raw wastewater arsenic concentrations as high as those of the Japanese plant; however, the arsenic concentrations from the U.S. facility have been observed to range from 50-150 mg/l. Bench-scale tests were conducted using sulfide precipitation and filtration preliminary treatment in the same way as the full-scale Japanese plant. At a pH of 1.5 standard units with excess sodium sulfide, an arsenic concentration of 1.5 mg/l was achieved with this preliminary treatment. The fact that the concentration achieved for arsenic in the bench-scale tests is higher (1.5 mg/l as opposed to 0.03 mg/l) than that observed in the full-scale Japanese facility is not unexpected. The purpose of the bench-scale tests was to demonstrate that effective removal of arsenic was possible. These operating conditions were not optimized as they were in the full-scale facility. The bench-scale tests are described in greater detail in a report entitled Laboratory Studies on Sulfide Precipitation Applied to Metallurgical Acid Plant Wastewaters, found in the record supporting this rulemaking.

Sulfide precipitation may also be applied following or in conjunction with hydroxide precipitation (two-stage treatment-lime followed by sulfide). In these applications sulfide precipitation acts to further reduce toxic metal concentrations. Responses to Section 308 data collection portfolios indicate that there are four nonferrous metals manufacturing plants using sulfide precipitation as a polishing step - two primary zinc and two secondary silver plants.

EPA conducted bench-scale tests to examine the effectiveness of sulfide precipitation used in conjunction with lime precipitation and following lime and settle treatment. Sulfide precipitation

used in conjunction with lime precipitation applied to wastewater from a primary zinc process wastewater containing 1.4 mg/l of arsenic, 15 mg/l of cadmium, 7 mg/l of copper, 5 mg/l of lead and 114 mg/l of zinc, achieved effluent concentrations of 0.04 mg/l of arsenic, 0.05 mg/l of cadmium, 0.038 mg/l of copper, 0.027 mg/l of lead and 0.31 mg/l of zinc. Sulfide precipitation applied as a polishing step after lime precipitation achieved 0.04 mg/l of arsenic, 0.004 mg/l of cadmium, 0.014 mg/l of copper, 0.003 mg/l of lead and 0.036 mg/l of zinc when treating the same process wastewater.

Carbonate precipitation is sometimes used to precipitate metals, especially where precipitated metals values are to be recovered. The solubility of most metal carbonates is intermediate between hydroxide and sulfide solubilities; in addition, carbonates form easily filtered precipitates. Carbonate ions appear to be particularly useful in precipitating lead and antimony. Sodium carbonate has been observed being added at treatment to improve lead precipitation and removal in some industrial plants. The lead hydroxide and lead carbonate solubility curves displayed in Figure VII-3 (page 256) (Source: "Heavy Metals Removal," by Kenneth Lanovette, Chemical Engineering/Deskbook Issue, October 17, 1977) explain this phenomenon.

Co-precipitation With Iron. The presence of substantial quantities of iron in metal-bearing wastewaters before treatment has been shown to improve the removal of toxic metals. In some cases this iron is an integral part of the industrial wastewater; in other cases iron is deliberately added as a preliminary treatment or first step of treatment. The iron functions to improve toxic and other metals (such as molybdenum) removal by three mechanisms: the iron co-precipitates with toxic metals forming a stable precipitate which desolubilizes the toxic metal; the iron improves the settleability of the precipitate; and the large amount of iron reduces the fraction of toxic metal in the precipitate. Co-precipitation with iron has been practiced for many years incidentally when iron was a substantial constituent of raw wastewater and intentionally when iron salts were added as a coagulant aid. Aluminum or mixed iron-aluminum salt also have been used.

Co-precipitation using large amounts of ferrous iron salts is known as ferrite co-precipitation because magnetic iron oxide or ferrite is formed. The addition of ferrous salts (sulfate) is followed by alkali precipitation and air oxidation. The resultant precipitate is easily removed by filtration and may be removed magnetically. Data illustrating the performance of ferrite co-precipitation is shown in Table VII-7, (page 239).

Removal of PAH

EPA and its contractor conducted a series of bench- and pilot-scale tests examining the effectiveness of removing polynuclear aromatic hydrocarbons (PAH) from primary aluminum smelting

potline wet air pollution control wastewater. In the study, the effectiveness of lime and settle, multimedia filtration and activated carbon adsorption was examined. The study demonstrated that PAH commonly found in potline wet air pollution control wastewater can be removed by lime and settle technology. PAH present in the untreated potline scrubber liquor at concentrations ranging from 0.030 to 2.740 mg/l were reduced to less than 0.170 mg/l (ND to 0.170 mg/l) by lime and settle treatment.

Advantages and Limitations. Chemical precipitation has proved to be an effective technique for removing many pollutants from industrial wastewater. It operates at ambient conditions and is well suited to automatic control. The use of chemical precipitation may be limited because of interference by chelating agents, because of possible chemical interference with mixed wastewaters and treatment chemicals, or because of the potentially hazardous situation involved with the storage and handling of those chemicals. Nonferrous metals manufacturing wastewaters do not normally contain chelating agents or complex pollutant matrix formations which would interfere with or limit the use of chemical precipitation. One exception to this statement is wastewaters generated by secondary precious metals facilities. These wastewaters are expected to contain metal complexes which may require lime or sulfide addition to help overcome complexing effects.

Lime is usually added as a slurry when used in hydroxide precipitation. The slurry must be kept well mixed and the addition lines periodically checked to prevent blocking which may result from a build-up of solids. Also, lime precipitation usually makes recovery of the precipitated metals difficult, because of the heterogeneous nature of most lime sludges.

The major advantage of the sulfide precipitation process is that the extremely low solubility of most metal sulfides promotes very high metal removal efficiencies; the sulfide process also has the ability to remove chromates and dichromates without preliminary reduction of the chromium to its trivalent state. In addition, sulfide can precipitate metals complexed with most complexing agents. The process demands care, however, in maintaining the pH of the solution at approximately 10 in order to restrict the generation of toxic hydrogen sulfide gas. For this reason, ventilation of the treatment tanks may be a necessary precaution in most installations. The use of insoluble sulfides reduces the problem of hydrogen sulfide evolution. As with hydroxide precipitation, excess sulfide ion must be present to drive the precipitation reaction to completion. Since the sulfide ion itself is toxic, sulfide addition must be carefully controlled to maximize heavy metals precipitation with a minimum of excess sulfide to avoid the necessity of additional wastewater treatment. At very high excess sulfide levels and high pH, soluble mercury-sulfide compounds may also be formed. Where excess sulfide is present,

aeration of the effluent stream can aid in oxidizing residual sulfide to the less harmful sodium sulfate (Na_2SO_4). The cost of sulfide precipitants is high in comparison to hydroxide precipitants, and disposal of metallic sulfide sludges may pose problems. An essential element in effective sulfide precipitation is the removal of precipitated solids from the wastewater and proper disposal in an appropriate site. Sulfide precipitation will also generate a higher volume of sludge than hydroxide precipitation, resulting in higher disposal and dewatering costs. This is especially true when ferrous sulfide is used as the precipitant.

Sulfide precipitation may be used as a polishing treatment after hydroxide precipitation-sedimentation. This treatment configuration may provide the better treatment effectiveness of sulfide precipitation while minimizing the variability caused by changes in raw waste and reducing the amount of sulfide precipitant required.

Operational Factors. Reliability: Alkaline chemical precipitation is highly reliable, although proper monitoring and control are required. Sulfide precipitation systems provide similar reliability.

Maintainability: The major maintenance needs involve periodic upkeep of monitoring equipment, automatic feeding equipment, mixing equipment, and other hardware. Removal of accumulated sludge is necessary for efficient operation of precipitation-sedimentation systems.

Solid Waste Aspects: Solids which precipitate out are removed in a subsequent treatment step. Ultimately, these solids require proper disposal.

Demonstration Status. Chemical precipitation of metal hydroxides is a classic waste treatment technology used by most industrial waste treatment systems. Chemical precipitation of metals in the carbonate form alone has been found to be feasible and is commercially used to permit metals recovery and water reuse. Full-scale commercial sulfide precipitation units are in operation at numerous installations, including several plants in the nonferrous metals manufacturing category. As noted earlier, sedimentation to remove precipitates is discussed separately.

Use in Nonferrous Metals Manufacturing Plants: Hydroxide chemical precipitation is used at 121 nonferrous metals manufacturing plants. Sulfide precipitation is used in four nonferrous metals manufacturing plants.

3. Cyanide Precipitation

Cyanide precipitation, although a method for treating cyanide in wastewaters, does not destroy cyanide. The cyanide is retained in the sludge that is formed. Reports indicate that during exposure to sunlight, the cyanide complexes can break down and

form free cyanide. For this reason, the sludge from this treatment method must be disposed of carefully.

Cyanide may be precipitated and settled out of wastewaters by the addition of zinc sulfate or ferrous sulfate. In the presence of iron, cyanide will form extremely stable cyanide complexes. The addition of zinc sulfate or ferrous sulfate forms zinc ferrocyanide or ferro ferricyanide complexes.

Cyanide precipitation occurs in two steps: reaction with ferrous sulfate or zinc sulfate at an alkaline pH to form iron or zinc cyanide complexes followed by reaction at a low pH with additional ferrous sulfate to form insoluble iron cyanide precipitates. Cyanide precipitation is applicable to all cyanide containing wastewater and, unlike many oxidation technologies, is not limited by the presence of complexed cyanides. The oxidation technologies discussed later in this section are applicable for waste streams containing only uncomplexed cyanides. Cyanide precipitation has been selected as the technology basis for cyanide control because of the presence of iron, nickel, and zinc in wastewaters in this category. These toxic metals are known to form stable complexes with cyanide.

Cyanide-containing wastewater is introduced into a mixing chamber where ferrous sulfate (as the heptahydrate $(\text{FeSO}_4 \cdot 7(\text{H}_2\text{O}))$), is added to form a hexacyanoferrate complex. The hexacyanoferrate complex is most stable at a pH of 9 (standard units). Thus, the complexation reaction is performed at pH 9. The amount or dosage of ferrous sulfate is dependent upon the chemical form of the cyanide in the wastewater. Cyanide may be present in one of two forms, free or complexed (sometimes referred to as fixed). Various analytical methods to determine the portions of free and complexed cyanides in wastewater are discussed in the open literature. Free cyanide refers to the portion of total cyanide that freely dissociates in water (e.g., HCN).

When ferrous sulfate is added to the wastewater at pH 9, the ferrous ion readily oxidizes to the ferric ion. The complexation step is then expected to occur as follows:

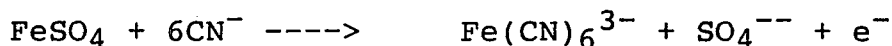

To a lesser degree, the free cyanide may also be complexed according to:



Complexed cyanide, present as the hexacyanoferrate or metalocyanide complexes, is already in the desired chemical form. In theory, the ferrous sulfate dosage is determined by calculating the stoichiometric equivalent required for the free cyanide present, that is, one mole of ferrous sulfate per six moles of cyanide. In actual practice, the dosage requirements are greater than the stoichiometric equivalent. One reason

that excess ferrous sulfate is required is that the complexation reaction is very slow and the excess of reactants increases the reaction rate. Another reason is that in treatment systems, where lime or other sources of hydroxide ions are added to raise the pH to 8, some of the lime will react with the ferrous sulfate to form calcium sulfate.

After forming the complex, the wastewater is then mixed with additional ferrous sulfate and the pH adjusted using acid (e.g., H₂SO₄) in the range of 2 to 4. The ferrous sulfate reacts with the hexacyanoferrate to form ferroxhexacyanoferrate, according to:

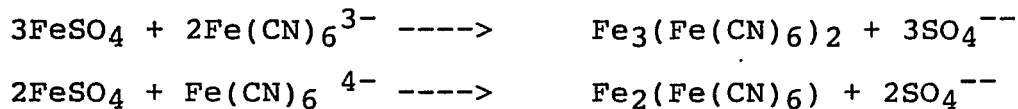

It appears that it may also be possible to use ferric chloride in the precipitation step, according to:

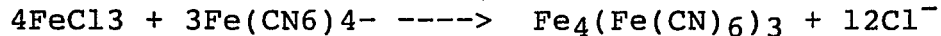

However, based on data obtained from cyanide-bearing waters in the primary aluminum industry, ferric chloride did not increase the amount of cyanide precipitate formed. In wastewaters obtained from two different facilities, the dosage of ferrous sulfate was held constant while the dosage of ferric chloride was varied. Results from both plants indicate that the addition of ferric chloride has little, if any, effect on the precipitation chemistry.

Following complexation the wastewater is introduced into a clarifier to allow these insoluble precipitates to settle. Sedimentation (settling) is discussed in a later subsection.

Adequate complexation of cyanide requires that the pH must be kept at 9.0 and an appropriate retention time be maintained. A study has shown that the formation of the complex is very dependent on pH. At a pH of either 8 or 10, the residual cyanide concentrations measured are twice that of the same reaction carried out at a pH of 9. Removal efficiencies also depend heavily on the retention time allowed. The formation of the complexes takes place rather slowly. Depending upon the excess amount of zinc sulfate or ferrous sulfate added, at least a 30 minute retention time should be allowed for the formation of the cyanide complex before continuing on to the clarification stage.

One experiment with an initial concentration of 10 mg/l of cyanide showed that 98 percent of the cyanide was complexed ten minutes after the addition of ferrous sulfate at twice the theoretical amount necessary. Interference from other metal ions, such as cadmium, might result in the need for longer retention times.

Table VII-8 (page 239) presents cyanide precipitation data from three coil coating plants. A fourth plant was visited for the purpose of observing plant testing of the cyanide precipitation system. Specific data from this facility are not included because: (1) the pH was usually well below the optimum level of 9.0; (2) the historical treatment data were not obtained using the standard cyanide analysis procedure; and (3) matched input-output data were not made available by the plant. Scanning the available data indicates that the raw waste CN level was in the range of 25.0; the pH 7.5; and treated CN level was from 0.1 to 0.2.

The concentrations are those of the stream entering and leaving the treatment system. Plant 1057 allowed a 27-minute retention time for the formation of the complex. The retention time for the other plants is not known. The data suggest that over a wide range of cyanide concentration in the raw waste, the concentration of cyanide can be reduced in the effluent stream to under 0.15 mg/l.

Application and Performance. Cyanide precipitation can be used when cyanide destruction is not feasible because of the presence of cyanide complexes which are difficult to destroy. Effluent concentrations of cyanide well below 0.15 mg/l are possible.

Advantages and Limitations. Cyanide precipitation is an inexpensive method of treating cyanide. Problems may occur when metal ions interfere with the formation of the complexes.

4. Granular Bed Filtration

Filtration occurs in nature as surface and ground waters are cleansed by sand. Silica sand, anthracite coal, and garnet are common filter media used in water treatment plants. These are usually supported by gravel. The media may be used singly or in combination. The multi-media filters may be arranged to maintain relatively distinct layers by virtue of balancing the forces of gravity, flow, and buoyancy on the individual particles. This is accomplished by selecting appropriate filter flow rates (gpm/sq-ft), media grain size, and density.

Granular bed filters may be classified in terms of filtration rate, filter media, flow pattern, or method of pressurization. Traditional rate classifications are slow sand, rapid sand, and high rate mixed media. In the slow sand filter, flux or hydraulic loading is relatively low, and removal of collected solids to clean the filter is therefore relatively infrequent. The filter is often cleaned by scraping off the inlet face (top) of the sand bed. In the higher rate filters, cleaning is frequent and is accomplished by a periodic backwash, opposite to the direction of normal flow.

A filter may use a single medium such as sand or diatomaceous earth, but dual and mixed (multiple) media filters allow higher flow rates and efficiencies. The dual media filter usually

consists of a fine bed of sand under a coarser bed of anthracite coal. The coarse coal removes most of the influent solids, while the fine sand performs a polishing function. At the end of the backwash, the fine sand settles to the bottom because it is denser than the coal, and the filter is ready for normal operation. The mixed media filter operates on the same principle, with the finer, denser media at the bottom and the coarser, less dense media at the top. The usual arrangement is garnet at the bottom (outlet end) of the bed, sand in the middle, and anthracite coal at the top. Some mixing of these layers occurs and is, in fact, desirable.

The flow pattern is usually top-to-bottom, but other patterns are sometimes used. Upflow filters are sometimes used, and in a horizontal filter the flow is horizontal. In a biflow filter, the influent enters both the top and the bottom and exits laterally. The advantage of an upflow filter is that with an upflow backwash, the particles of a single filter medium are distributed and maintained in the desired coarse-to-fine (bottom-to-top) arrangement. The disadvantage is that the bed tends to become fluidized, which ruins filtration efficiency. The biflow design is an attempt to overcome this problem.

The classic granular bed filter operates by gravity flow; however, pressure filters are fairly widely used. They permit higher solids loadings before cleaning and are advantageous when the filter effluent must be pressurized for further downstream treatment. In addition, pressure filter systems are often less costly for low to moderate flow rates.

Figure VII-14 (page 267) depicts a high rate, dual media, gravity downflow granular bed filter, with self-stored backwash. Both filtrate and backwash are piped around the bed in an arrangement that permits gravity upflow of the backwash, with the stored filtrate serving as backwash. Addition of the indicated coagulant and polyelectrolyte usually results in a substantial improvement in filter performance.

Auxiliary filter cleaning is sometimes employed in the upper few inches of filter beds. This is conventionally referred to as surface wash and is accomplished by water jets just below the surface of the expanded bed during the backwash cycle. These jets enhance the scouring action in the bed by increasing the agitation.

An important feature for successful filtration and backwashing is the underdrain. This is the support structure for the bed. The underdrain provides an area for collection of the filtered water without clogging from either the filtered solids or the media grains. In addition, the underdrain prevents loss of the media with the water, and during the backwash cycle it provides even flow distribution over the bed. Failure to dissipate the velocity head during the filter or backwash cycle will result in bed upset and the need for major repairs.

Several standard approaches are employed for filter underdrains. The simplest one consists of a parallel porous pipe embedded under a layer of coarse gravel and manifolded to a header pipe for effluent removal. Other approaches to the underdrain system are known as the Leopold and Wheeler filter bottoms. Both of these incorporate false concrete bottoms with specific porosity configurations to provide drainage and velocity head dissipation.

Filter system operation may be manual or automatic. The filter backwash cycle may be on a timed basis, a pressure drop basis with a terminal value which triggers backwash, or a solids carry-over basis from turbidity monitoring of the outlet stream. All of these schemes have been used successfully.

Application and Performance. Wastewater treatment plants often use granular bed filters for polishing after clarification, sedimentation, or other similar operations. Granular bed filtration thus has potential application to nearly all industrial plants. Chemical additives which enhance the upstream treatment equipment may or may not be compatible with or enhance the filtration process. Normal operating flow rates for various types of filters are:

Slow Sand	2.04 - 5.30	l/sq m-hr
Rapid Sand	40.74 - 51.48	l/sq m-hr
High Rate Mixed Media	81.48 - 122.22	l/sq m-hr

Suspended solids are commonly removed from wastewater streams by filtering through a deep 0.3-0.9 m (1-3 feet) granular filter bed. The porous bed formed by the granular media can be designed to remove practically all suspended particles. Even colloidal suspensions (roughly 1 to 100 microns) are adsorbed on the surface of the media grains as they pass in close proximity in the narrow bed passages.

Properly operated filters following some pretreatment to reduce suspended solids below 200 mg/l should produce water with less than 10 mg/l TSS. For example, multimedia filters produced the effluent qualities shown in Table VII-9 (page 240).

The addition of multimedia filtration to lime precipitation and sedimentation resulted in further reduction of the PAH; all less than 0.110 mg/l. Benzo(a)pyrene was reduced to the analytical quantification limit of 0.010 mg/l. The study conducted on potline scrubber liquor is discussed more fully in Section VII of the primary aluminum subcategory supplement and in a report entitled Physical-Chemical Treatment of Aluminum Plant Potline Scrubber Wastewater, found in the record supporting this rule.

Advantages and Limitations. The principal advantages of granular bed filtration are its comparatively (to other filters) low initial and operating costs, reduced land requirements over other methods to achieve the same level of solids removal, and

elimination of chemical additions to the discharge stream. However, the filter may require pretreatment if the solids level is high (over 100 mg/l). Operator training must be somewhat extensive due to the controls and periodic backwashing involved, and backwash must be stored and dewatered for economical disposal.

Operational Factors. Reliability: The recent improvements in filter technology have significantly improved filtration reliability. Control systems, improved designs, and good operating procedures have made filtration a highly reliable method of water treatment.

Maintainability: Deep bed filters may be operated with either manual or automatic backwash. In either case, they must be periodically inspected for media attrition, partial plugging, and leakage. Where backwashing is not used, collected solids must be removed by shoveling, and filter media must be at least partially replaced.

Solid Waste Aspects: Filter backwash is generally recycled within the wastewater treatment system, so that the solids ultimately appear in the clarifier sludge stream for subsequent dewatering. Alternatively, the backwash stream may be dewatered directly or, if there is no backwash, the collected solids may be disposed of in a suitable landfill. In either of these situations there is a solids disposal problem similar to that of clarifiers.

Demonstration Status. Deep bed filters are in common use in municipal treatment plants. Their use in polishing industrial clarifier effluent is increasing, and the technology is proven and conventional. Granular bed filtration is used in 25 nonferrous metals manufacturing plants. As noted previously, however, little data is available characterizing the effectiveness of filters presently in use within the industry.

5. Pressure Filtration

Pressure filtration works by pumping the liquid through a filter material which is impenetrable to the solid phase. The positive pressure exerted by the feed pumps or other mechanical means provides the pressure differential which is the principal driving force. Figure VII-15 (page 268) represents the operation of one type of pressure filter.

A typical pressure filtration unit consists of a number of plates or trays which are held rigidly in a frame to ensure alignment and which are pressed together between a fixed end and a traveling end. On the surface of each plate, a filter made of cloth or synthetic fiber is mounted. The feed stream is pumped into the unit and passes through holes in the trays along the length of the press until the cavities or chambers between the trays are completely filled. The solids are then entrapped, and a cake begins to form on the surface of the filter material. The

water passes through the fibers, and the solids are retained.

At the bottom of the trays are drainage ports. The filtrate is collected and discharged to a common drain. As the filter medium becomes coated with sludge, the flow of filtrate through the filter drops sharply, indicating that the capacity of the filter has been exhausted. The unit must then be cleaned of the sludge. After the cleaning or replacement of the filter media, the unit is again ready for operation.

Application and Performance. Pressure filtration is used in nonferrous metals manufacturing for sludge dewatering and also for direct removal of precipitated and other suspended solids from wastewater. Because dewatering is such a common operation in treatment systems, pressure filtration is a technique which can be found in many industries concerned with removing solids from their waste stream.

In a typical pressure filter, chemically preconditioned sludge detained in the unit for one to three hours under pressures varying from 5 to 13 atmospheres exhibited final solids content between 25 and 50 percent.

Advantages and Limitations. The pressures which may be applied to a sludge for removal of water by filter presses that are currently available range from 5 to 13 atmospheres. As a result, pressure filtration may reduce the amount of chemical pretreatment required for sludge dewatering. Sludge retained in the form of the filter cake has a higher percentage of solids than that from centrifuge or vacuum filter. Thus, it can be easily accommodated by materials handling systems.

As a primary solids removal technique, pressure filtration requires less space than clarification and is well suited to streams with high solids loadings. The sludge produced may be disposed without further dewatering, but the amount of sludge is increased by the use of filter precoat materials (usually diatomaceous earth). Also, cloth pressure filters often do not achieve as high a degree of effluent clarification as clarifiers or granular media filters.

Two disadvantages associated with pressure filtration in the past have been the short life of the filter cloths and lack of automation. New synthetic fibers have largely offset the first of these problems. Also, units with automatic feeding and pressing cycles are now available.

For larger operations, the relatively high space requirements, as compared to those of a centrifuge, could be prohibitive in some situations.

Operational Factors. Reliability: With proper pretreatment, design, and control, pressure filtration is a highly dependable system.

Maintainability: Maintenance consists of periodic cleaning or replacement of the filter media, drainage grids, drainage piping, filter pans, and other parts of the system. If the removal of the sludge cake is not automated, additional time is required for this operation.

Solid Waste Aspects: Because it is generally drier than other types of sludges, the filter sludge cake can be handled with relative ease. The accumulated sludge may be disposed by any of the accepted procedures depending on its chemical composition.

Demonstration Status. Pressure filtration is a commonly used technology in a great many commercial applications.

6. Settling

Settling is a process which removes solid particles from a liquid matrix by gravitational force. This is done by reducing the velocity of the feed stream in a large volume tank or lagoon so that gravitational settling can occur. Figure VII-16 (page 269) shows two typical settling devices.

Settling is often preceded by chemical precipitation which converts dissolved pollutants to solid form and by coagulation which enhances settling by coagulating suspended precipitates into larger, faster settling particles.

If no chemical pretreatment is used, the wastewater is fed into a tank or lagoon where it loses velocity and the suspended solids are allowed to settle out. Long retention times are generally required. Accumulated sludge can be collected either periodically or continuously and either manually or mechanically. Simple settling, however, may require excessively large catchments, and long retention times (days as compared with hours) to achieve high removal efficiencies. Because of this, addition of settling aids such as alum or polymeric flocculants is often economically attractive.

In practice, chemical precipitation often precedes settling, and inorganic coagulants or polyelectrolytic flocculants are usually added as well. Common coagulants include sodium sulfate, sodium aluminate, ferrous or ferric sulfate, and ferric chloride. Organic polyelectrolytes vary in structure, but all usually form larger floc particles than coagulants used alone.

Following this pretreatment, the wastewater can be fed into a holding tank or lagoon for settling, but is more often piped into a clarifier for the same purpose. A clarifier reduces space requirements, reduces retention time, and increases solids removal efficiency. Conventional clarifiers generally consist of a circular or rectangular tank with a mechanical sludge collecting device or with a sloping funnel-shaped bottom designed for sludge collection. In advanced settling devices, inclined plates, slanted tubes, or a lamellar network may be included within the clarifier tank in order to increase the effective

settling area, increasing capacity. A fraction of the sludge stream is often recirculated to the inlet, promoting formation of a denser sludge.

Settling is based on the ability of gravity (Newton's Law) to cause small particles to fall or settle (Stokes' Law) through the fluid they are suspended in. Presuming that the factors affecting chemical precipitation are controlled to achieve a readily settleable precipitate, the principal factors controlling settling are the particle characteristics and the upflow rate of the suspending fluid. When the effective settling area is great enough to allow settling, any increase in the effective settling area will produce no increase in solids removal.

Therefore, if a plant has installed equipment that provides the appropriate overflow rate, the precipitated solids (including toxic metals) in the effluent can be effectively removed. The number of settling devices operated in series or in parallel by a facility is not important with regard to suspended solids removal. Rather, it is important that the settling devices provide sufficient effective settling area.

Another important facet of sedimentation theory is that diminishing removal of suspended solids is achieved for a unit increase in the effective settling area. Generally, it has been found that suspended solids removal performance varies with the effective up-flow rate. Qualitatively the performance increases asymptotically to a maximum level beyond which a decrease in up-flow rate provides incrementally insignificant increases in removal. This maximum level is dictated by particle size distribution, density characteristic of the particles and the water matrix, chemicals used for precipitation and pH at which precipitation occurs.

Application and Performance. Settling and clarification are used in the nonferrous metals manufacturing category to remove precipitated metals. Settling can be used to remove most suspended solids in a particular waste stream; thus it is used extensively by many different industrial waste treatment facilities. Because most metal ion pollutants are readily converted to solid metal hydroxide precipitates, settling is of particular use in those industries associated with metal production, metal finishing, metal working, and any other industry with high concentrations of metal ions in their wastewaters. In addition to toxic metals, suitably precipitated materials effectively removed by settling include aluminum, iron, manganese, cobalt, antimony, beryllium, molybdenum, fluoride, phosphate, and many others.

A properly operating settling system can efficiently remove suspended solids, precipitated metal hydroxides, and other impurities from wastewater. The performance of the process depends on a variety of factors, including the density and particle size of the solids, the effective charge on the suspended particles, and the types of chemicals used in

pretreatment. The site of flocculant or coagulant addition also may significantly influence the effectiveness of clarification. If the flocculant is subjected to too much mixing before entering the clarifier, the complexes may be sheared and the settling effectiveness diminished. At the same time, the flocculant must have sufficient mixing and reaction time in order for effective set-up and settling to occur. Plant personnel have observed that the line or trough leading into the clarifier is often the most efficient site for flocculant addition. The performance of simple settling is a function of the movement rate, particle size and density, and the surface area of the basin.

The data displayed in Table VII-10 (page 240) indicate suspended solids removal efficiencies in settling systems.

The mean effluent TSS concentration obtained by the plants shown in Table VII-10 is 10.1 mg/l. Influent concentrations averaged 838 mg/l. The maximum effluent TSS value reported is 23 mg/l. These plants all use alkaline pH adjustment to precipitate metal hydroxides, and most add a coagulant or flocculant prior to settling.

Advantages and Limitations. The major advantage of simple settling is its simplicity as demonstrated by the gravitational settling of solid particulate waste in a holding tank or lagoon. The major problem with simple settling is the long retention time necessary to achieve complete settling, especially if the specific gravity of the suspended matter is close to that of water. Some materials cannot be practically removed by simple settling alone.

Settling performed in a clarifier is effective in removing slow-settling suspended matter in a shorter time and in less space than a simple settling system. Also, effluent quality is often better from a clarifier. The cost of installing and maintaining a clarifier, however, is substantially greater than the costs associated with simple settling.

Inclined plate, slant tube, and lamella settlers have even higher removal efficiencies than conventional clarifiers, and greater capacities per unit area are possible. Installed costs for these advanced clarification systems are claimed to be one half the cost of conventional systems of similar capacity.

Operational Factors. Reliability: Settling can be a highly reliable technology for removing suspended solids. Sufficient retention time and regular sludge removal are important factors affecting the reliability of all settling systems. Proper control of pH adjustment, chemical precipitation, and coagulant or flocculant addition are additional factors affecting settling efficiencies in systems (frequently clarifiers) where these methods are used.

Those advanced settlers using slanted tubes, inclined plates, or a lamellar network may require pre-screening of the waste in

order to eliminate any fibrous materials which could potentially clog the system. Some installations are especially vulnerable to shock loadings, as from storm water runoff, but proper system design will prevent this.

Maintainability: When clarifiers or other advanced settling devices are used, the associated system utilized for chemical pretreatment and sludge dragout must be maintained on a regular basis. Routine maintenance of mechanical parts is also necessary. Lagoons require little maintenance other than periodic sludge removal.

Demonstration Status. Settling represents the typical method of solids removal and is employed extensively in industrial waste treatment. The advanced clarifiers are just beginning to appear in significant numbers in commercial applications.

7. Skimming

Pollutants with a specific gravity less than water will often float unassisted to the surface of the wastewater. Skimming removes these floating wastes. Skimming normally takes place in a tank designed to allow the floating debris to rise and remain on the surface, while the liquid flows to an outlet located below the floating layer. Skimming devices are therefore suited to the removal of non-emulsified oils from raw waste streams. Common skimming mechanisms include the rotating drum type, which picks up oil from the surface of the water as it rotates. A doctor blade scrapes oil from the drum and collects it in a trough for disposal or reuse. The water portion is allowed to flow under the rotating drum. Occasionally, an underflow baffle is installed after the drum; this has the advantage of retaining any floating oil which escapes the drum skimmer. The belt type skimmer is pulled vertically through the water, collecting oil which is scraped off from the surface and collected in a drum. Gravity separators, such as the API type, utilize overflow and underflow baffles to skim a floating oil layer from the surface of the wastewater. An overflow-underflow baffle allows a small amount of wastewater (the oil portion) to flow over into a trough for disposition or reuse while the majority of the water flows underneath the baffle. This is followed by an overflow baffle, which is set at a height relative to the first baffle such that only the oil bearing portion will flow over the first baffle during normal plant operation. A diffusion device, such as a vertical slot baffle, aids in creating a uniform flow through the system and in increasing oil removal efficiency.

Application and Performance. Oil skimming is used in nonferrous metals manufacturing to remove free oil and grease used as lubricants in some types of metal casting. Another source of oil is lubricants for drive mechanisms and other machinery contacted by process water. Skimming is applicable to any waste stream containing pollutants which float to the surface. It is commonly used to remove free oil, grease, and soaps. Skimming is often used in conjunction with air flotation or clarification in order

to increase its effectiveness.

The removal efficiency of a skimmer is partly a function of the retention time of the water in the tank. Larger, more buoyant particles require less retention time than smaller particles. Thus, the efficiency also depends on the composition of the waste stream. The retention time required to allow phase separation and subsequent skimming varies from 1 to 15 minutes, depending on the wastewater characteristics.

API or other gravity-type separators tend to be more suitable for use where the amount of surface oil flowing through the system is consistently significant. Drum and belt type skimmers are applicable to waste streams which evidence smaller amounts of floating oil and where surges of floating oil are not a problem. Using an API separator system in conjunction with a drum type skimmer would be a very effective method of removing floating contaminants from non-emulsified oily waste streams. Sampling data shown in Table VII-11 (page 241) illustrate the capabilities of the technology with both extremely high and moderate oil influent levels.

These data are intended to be illustrative of the very high level of oil and grease removals attainable in a simple two-step oil removal system. Based on the performance of installations in a variety of manufacturing plants and permit requirements that are consistently achieved, it is determined that effluent oil levels may be reliably reduced below 10 mg/l with moderate influent concentrations. Very high concentrations of oil such as the 22 percent shown above may require two-step treatment to achieve this level.

Skimming which removes oil may also be used to remove base levels of organics. Plant sampling data show that many organic compounds tend to be removed in standard wastewater treatment equipment. Oil separation not only removes oil but also organics that are more soluble in oil than in water. Clarification removes organic solids directly and probably removes dissolved organics by adsorption on inorganic solids.

The source of these organic pollutants is not always known with certainty, although in metal forming operations they seem to derive mainly from various process lubricants. They are also sometimes present in the plant water supply, as additives to proprietary formulations of cleaners, or as the result of leaching from plastic lines and other materials.

High molecular weight organics in particular are much more soluble in organic solvents than in water. Thus they are much more concentrated in the oil phase that is skimmed than in the wastewater. The ratio of solubilities of a compound in oil and water phases is called the partition coefficient. The logarithm of the partition coefficients for selected polynuclear aromatic hydrocarbon (PAH) and other toxic organic compounds in octanol and water are shown in Table VII-12 (page 241).

A review of priority organic compounds commonly found in metal forming operation waste streams indicated that incidental removal of these compounds often occurs as a result of oil removal or clarification processes. When all organics analyses from visited plants are considered, removal of organic compounds by other waste treatment technologies appears to be marginal in many cases. However, when only raw waste concentrations of 0.05 mg/l or greater are considered, incidental organics removal becomes much more apparent. Lower values, those less than 0.05 mg/l, are much more subject to analytical variation, while higher values indicate a significant presence of a given compound. When these factors are taken into account, analysis data indicate that most clarification and oil removal treatment systems remove significant amounts of the toxic organic compounds present in the raw waste. The API oil-water separation system performed notably in this regard, as shown in Table VII-13 (page 242).

Data from five plant days demonstrate removal of organics by the combined oil skimming and settling operations performed on coil coating wastewaters. Days were chosen where treatment system influent and effluent analyses provided paired data points for oil and grease and the organics present. All organics found at quantifiable levels on those days were included. Further, only those days were chosen where oil and grease raw wastewater concentrations exceeded 10 mg/l and where there was reduction in oil and grease going through the treatment system. All plant sampling days which met the above criteria are included below. The conclusion is that when oil and grease are removed, organics also are removed.

Plant-Day	Percent Removal	
	Oil & Grease	Organics
1054-3	95.9	98.2
13029-2	98.3	78.0
13029-3	95.1	77.0
38053-1	96.8	81.3
38053-2	98.5	86.3
Mean	96.9	84.2

The unit operation most applicable to removal of trace priority organics is adsorption, and chemical oxidation is another possibility. Biological degradation is not generally applicable because the organics are not present in sufficient concentration to sustain a biomass and because most of the organics are resistant to biodegradation.

Advantages and Limitations. Skimming as a pretreatment is effective in removing naturally floating waste material. It also improves the performance of subsequent downstream treatments. Many pollutants, particularly dispersed or emulsified oil, will

not float "naturally" but require additional treatments. Therefore, skimming alone may not remove all the pollutants capable of being removed by air flotation or other more sophisticated technologies.

Operational Factors. Reliability: Because of its simplicity, skimming is a very reliable technique.

Maintainability: The skimming mechanism requires periodic lubrication, adjustment, and replacement of worn parts.

Solid Waste Aspects: The collected layer of debris must be disposed of by contractor removal, landfill, or incineration. Because relatively large quantities of water are present in the collected wastes, incineration is not always a viable disposal method.

Demonstration Status. Skimming is a common operation utilized extensively by industrial waste treatment systems. Oil skimming is used in four nonferrous metals manufacturing plants.

MAJOR TECHNOLOGY EFFECTIVENESS

The performance of individual treatment technologies was presented above. Performance of operating systems is discussed here. Two different systems are considered: L&S (hydroxide precipitation and sedimentation or lime and settle) and LS&F (hydroxide precipitation, sedimentation, and filtration or lime, settle, and filter). Subsequently, an analysis of effectiveness of such systems is made to develop one-day maximum, ten-day and thirty-day average concentration levels to be used in regulating pollutants. Evaluation of the L&S and the LS&F systems is carried out on the assumption that chemical reduction of chromium, cyanide precipitation and oil removal are installed and operating properly where appropriate.

L&S Performance -- Combined Metals Data Base

A data base known as the "combined metals data base" (CMDB) was used to determine treatment effectiveness of lime and settle treatment for certain pollutants. The CMDB was developed over several years and has been used in a number of regulations. During the development of coil coating and other categorical effluent limitations and standards, chemical analysis data were collected of raw wastewater (treatment influent) and treated wastewater (treatment effluent) from 55 plants (126 data days) sampled by EPA (or its contractor) using EPA sampling and chemical analysis protocols. These data are the initial data base for determining the effectiveness of L&S technology in treating nine pollutants. Each of the plants in the initial data base belongs to at least one of the following industry categories: aluminum forming, battery manufacturing, coil coating (including canmaking), copper forming, electroplating and porcelain enameling. All of the plants employ pH adjustment and hydroxide precipitation using lime or caustic, followed by

Stokes' law settling (tank, lagoon or clarifier) for solids removal. An analysis of this data was presented in the development documents for the proposed regulations for coil coating and porcelain enameling (January 1981). Prior to analyzing the data, some values were deleted from the data base. These deletions were made to ensure that the data reflect properly operated treatment systems. The following criteria were used in making these deletions:

- Plants where malfunctioning processes or treatment systems at the time of sampling were identified.
- Data days where pH was less than 7.0 for extended periods of time or TSS was greater than 50 mg/l (these are prima facie indications of poor operation).

In response to the coil coating and porcelain enameling proposals, some commenters claimed that it was inappropriate to use data from some categories for regulation of other categories. In response to these comments, the Agency reanalyzed the data. An analysis of variance was applied to the data for the 126 days of sampling to test the hypothesis of homogeneous plant mean raw and treated effluent levels across categories by pollutant. This analysis is described in the report "A Statistical Analysis of the Combined Metals Industries Effluent Data" which is in the administrative record supporting this rulemaking. Homogeneity is the absence of statistically discernible differences among the categories, while heterogeneity is the opposite (i.e., the presence of statistically discernible differences). The main conclusion drawn from the analysis of variance is that, with the exception of electroplating, the categories included in the data base are generally homogeneous with regard to mean pollutant concentrations in both raw and treated effluent. That is, when data from electroplating facilities are included in the analysis, the hypothesis of homogeneity across categories is rejected. When the electroplating data are removed from the analysis the conclusion changes substantially and the hypothesis of homogeneity across categories is not rejected. On the basis of this analysis, the electroplating data were removed from the data base used to determine limitations for the final coil coating, porcelain enameling, copper forming, aluminum forming, battery manufacturing, nonferrous metals manufacturing, nonferrous metals forming, and canmaking regulations.

Analytical data from nonferrous metals manufacturing treatment systems which include paired raw waste influent treatment and treated effluent are limited to nine plants with lime precipitation and sedimentation systems. Three of these systems were deemed to be inappropriate for consideration in establishing treatment effectiveness concentration for nonferrous metals manufacturing. Two of the plants had large non-scope flows entering the treatment system and the third had

high TSS (N 1000 mg/l) concentrations at the outfall of its lime and settle treatment system; concentrations indicative of poor system operation. The treated data from six of these nine nonferrous metals manufacturing plants with properly operated lime precipitation and sedimentation systems were compared to the achievable concentrations derived using the combined metals data base. These data generally supported the combined metals data base concentrations. These data and the analysis performed using the data are in the administrative record supporting this rulemaking.

EPA examined the homogeneity among nonferrous metals manufacturing subcategories, as well as across the combined metals data base. Homogeneity is the absence of statistically discernible differences among mean untreated pollutant concentrations observed in a set of data. The purpose of these analyses was to corroborate the Agency's engineering judgment that the untreated wastewater characteristics observed in the nonferrous category were similar to those observed in the combined metals data. Establishment of similarity of raw wastes through a statistical assessment provides further support to EPA's assumption that lime and settle treatment reduces the toxic metal pollutant concentrations in untreated nonferrous metals manufacturing wastewater to concentrations achieved by the same technology applied to the wastewater from the categories in the combined metals data base. In general, the results of the analysis showed that the nonferrous subcategories are homogeneous with respect to mean pollutant concentrations across subcategories. Comparison of the untreated nonferrous metals manufacturing data combined across subcategories and the combined metals data also showed good agreement.

The homogeneity observed among the nonferrous untreated data and the combined metals data supports the hypothesis of similar untreated wastewater characteristics and suggests that lime and settle treatment would reduce the concentrations of toxic metal pollutants in the nonferrous metals manufacturing to concentrations comparable to those achievable by lime and settle treatment of wastewater from the categories included in the combined metals data base.

There were several exceptions to the general finding of homogeneity among the industrial categories discussed above. The exceptional cases include:

1. Primary aluminum - cathode reprocessing wastewater and potline wet air pollution control wastewater commingled with cathode reprocessing wastewater.
2. Primary lead, zinc, and metallurgical acid plants - all process wastewater.
3. The primary beryllium subcategory has higher beryllium concentrations in the untreated wastewater than other plants in

phase II.

4. The secondary precious metals subcategory has higher zinc concentrations in the untreated wastewater than other plants in phase II.

5. The untreated nickel concentrations in specific secondary tungsten and cobalt plants are higher than in the plants in the combined metals data base.

These first two special cases are discussed later in this section.

EPA is considering the use of sulfide precipitation in conjunction with lime and settle, and lime, settle and filtration for these three latter cases where the influent metals concentrations are higher than those observed in the combined metals data base. These special cases are discussed in a memorandum entitled "Analysis of the Wastewater Pollutant Concentrations from the Phase II Subcategories of the Nonferrous Metals Manufacturing Category," found in the record supporting this rulemaking. The combined metals data base as discussed below is applicable to all nonferrous metals manufacturing wastewater as demonstrated by the homogeneity.

Properly operated hydroxide precipitation and sedimentation will result in effluent concentrations that are directly related to pollutant solubilities. Since the nonferrous metals manufacturing raw wastewater matrix contains the same toxic pollutants in the same order of magnitude as the combined metals data base, the treatment process effluent long-term performance and variability will be quite similar. In addition, interfering properties (such as chelating agents) usually do not exist in nonferrous metals manufacturing wastewater that would interfere with metal precipitation and so prevent attaining concentrations calculated from the combined metals data base.

It should be noted, however, that statistical analyses indicate that the raw wastewater matrix in nonferrous metals manufacturing contains higher concentrations of lead and cadmium than the raw wastewater of plants used for the combined metals data base. Because the precipitation (and ultimate removal by sedimentation) of these metals is directly related to their solubility, EPA believes that the differences in raw waste concentrations, while statistically significant, are not large enough to alter the achievable concentrations following treatment.

The statistical analysis provides support for the technical engineering judgment that electroplating wastewaters are sufficiently different from the wastewaters of other industrial categories in the data base to warrant removal of electroplating data from the data base used to determine treatment effectiveness.

For the purpose of determining treatment effectiveness, additional data were deleted from the data base. These deletions were made, almost exclusively, in cases where effluent data points were associated with low influent values. This was done in two steps. First, effluent values measured on the same day as influent values that were less than or equal to 0.1 mg/l were deleted. Second, the remaining data were screened for cases in which all influent values at a plant were low although slightly above the 0.1 mg/l value. These data were deleted not as individual data points but as plant clusters of data that were consistently low and thus not relevant to assessing treatment. A few data points were also deleted where malfunctions not previously identified were recognized. The data basic to the CMDB are displayed graphically in Figures VII-4 to 12 (Pages 257 to 265).

After all deletions, 148 data points from 19 plants remained. These data were used to determine the concentration basis of limitations derived from the CMDB used for the proposed nonferrous metals manufacturing regulations.

The CMDB was reviewed following its use in a number of proposed regulations (including nonferrous metals manufacturing). Comments pointed out a few errors in the data and the Agency's review identified a few transcription errors and some data points that were appropriate for inclusion in the data that had not been used previously because of errors in data record identification numbers. Documents in the record of this rulemaking identify all the changes, the reasons for the changes, and the effect of these changes on the data base. Comments on other proposed regulations asserted that the data base was too small and that the statistical methods used were overly complex. Responses to specific comments are provided in a document included in the record of this rulemaking. The Agency believes that the data base is adequate to determine effluent concentrations achievable with lime and settle treatment. The statistical methods employed in the analysis are well known and appropriate statistical references are provided in the documents in the record that describe the analysis.

The revised data base was re-examined for homogeneity. The earlier conclusions were unchanged. The categories show good overall homogeneity with respect to concentrations of the nine pollutants in both raw and treated wastewaters with the exception of electroplating.

The same procedures used in developing limitations for nonferrous metals manufacturing from the combined metals data base were then used on the revised data base. That is, certain effluent data associated with low influent values were deleted, and then the remaining data were fit to a lognormal distribution to determine limitations values. The deletion of data was done in two steps. First, effluent values measured on the same day as influent values that were less than or equal to 0.1 mg/l were deleted. Second, the remaining data were screened

for cases in which all influent values at a plant were low although slightly above the 0.1 mg/l value. These data were deleted not as individual data points but as plant clusters of data that were consistently low and thus not relevant to assessing treatment.

One-day Effluent Values

The basic assumption underlying the determination of treatment effectiveness is that the data for a particular pollutant are lognormally distributed by plant. The lognormal has been found to provide a satisfactory fit to plant effluent data in a number of effluent guidelines categories and there was no evidence that the lognormal was not suitable in the case of the CMDDB. Thus, we assumed measurements of each pollutant from a particular plant, denoted by X, followed a lognormal distribution with log mean " μ " and log variance σ^2 . The mean, variance and 99th percentile of X are then:

$$\text{mean of } X = E(X) = \exp(\mu + \sigma^2/2)$$

$$\text{variance of } X = V(X) = \exp(2\mu + \sigma^2) [\exp(\sigma^2) - 1]$$

$$99\text{th percentile} = X_{.99} = \exp(\mu + 2.33\sigma)$$

where exp is e, the base of the natural logarithm. The term lognormal is used because the logarithm of X has a normal distribution with mean μ and variance σ^2 . Using the basic assumption of lognormality of the actual treatment effectiveness was determined using a lognormal distribution that, in a sense, approximates the distribution of an average of the plants in the data base, i.e., an "average plant" distribution. The notion of an "average plant" distribution is not a strict statistical concept but is used here to determine limits that would represent the performance capability of an average of the plants in the data base.

This "average plant" distribution for a particular pollutant was developed as follows: the log mean was determined by taking the average of all the observations for the pollutant across plants. The log variance was determined by the pooled within plant variance. This is the weighted average of the plant variances. Thus, the log mean represents the average of all the data for the pollutant and the log variance represents the average of the plant log variances or average plant variability for the pollutant.

The one day effluent values were determined as follows:

Let X_{ij} = the jth observation on a particular pollutant at plant i where

$i = 1, \dots, I$
 $j = 1, \dots, J_i$
 $I =$ total number of plants
 $J_i =$ number of observations at plant i .

Then $Y_{ij} = \ln X_{ij}$

where \ln means the natural logarithm.

Then $y =$ log mean over all plants

$$= \sum_{i=1}^I \sum_{j=1}^{J_i} y_{ij}/n,$$

where $n =$ total number of observations

$$= \sum_{i=1}^I J_i$$

and $V(y) =$ pooled log variance

$$= \frac{\sum_{i=1}^I (J_i - 1) S_i^2}{\sum_{i=1}^I (J_i - 1)}$$

where $S_i^2 =$ log variance at plant i

$$= \sum_{j=1}^{J_i} (y_{ij} - \bar{y}_i)^2 / (J_i - 1)$$

$\bar{y}_i =$ log mean at plant i .

Thus, y and $V(y)$ are the log mean and log variance, respectively, of the lognormal distribution used to determine the treatment effectiveness. The estimated mean and 99th percentile of this distribution form the basis for the long term average and daily maximum effluent limitations, respectively. The estimates are

$$\text{mean} = E(X) = \exp(y) \psi_n(0.5 V(y))$$

$$99\text{th percentile} = X_{.99} = \exp [y + 2.33 \sqrt{V(y)}]$$

where $\psi(\cdot)$ is a Bessel function and \exp is e , the base of the natural logarithms (See Aitchison, J. and J.A.C. Brown, The Lognormal Distribution, Cambridge University Press, 1963). In cases where zeros were present in the data, a generalized form of

the lognormal, known as the delta distribution was used (See Aitchison and Brown, op. cit., Chapter 9).

For certain pollutants, this approach was modified slightly to ensure that well-operated lime and settle plants in all CMDB categories would achieve the pollutant concentration values calculated from the CMDB. For instance, after excluding the electroplating data and other data that did not reflect pollutant removal or proper treatment, the effluent copper data from the copper forming plants were statistically significantly greater than the copper data from the other plants. This indicated that copper forming plants might have difficulty achieving an effluent concentration value calculated from copper data from all CMDB categories. Thus, copper effluent values shown in Table VII-14 (page 242) are based only on the copper effluent data from the copper forming plants. That is, the log mean for copper is the mean of the logs of all copper values from the copper forming plants only and the log variance is the pooled log variance of the copper forming plant data only. A similar situation occurred in the case of lead. That is, after excluding the electroplating data, the effluent lead data from battery manufacturing were significantly greater than the other categories. This indicated that battery manufacturing plants might have difficulty achieving a lead concentration calculated from all the CMDB categories. The lead values proposed in nonferrous metals manufacturing phase I were therefore based on the battery manufacturing lead data only. Comments on the proposed battery manufacturing regulation objected to this procedure and asserted that the lead concentration values were too low. Following proposal, the Agency obtained additional lead effluent data from a battery manufacturing facility with well-operated lime and settle treatment. These data were combined with the proposal lead data and analyzed to determine the final treatment effectiveness concentrations. The mean lead concentration is unchanged at 0.12 mg/l but the final one-day maximum and monthly 10-day average maximum increased to 0.42 and 0.20 mg/l, respectively. A complete discussion of the lead data and analysis is contained in a memorandum in the administrative record for this rulemaking.

In the case of cadmium, after excluding the electroplating data and data that did not reflect removal or proper treatment, there were insufficient data to estimate the log variance for cadmium. The variance used to determine the values shown in Table VII-14 for cadmium was estimated by pooling the within plant variances for all the other metals. Thus, the cadmium variability is the average of the plant variability averaged over all the other metals. The log mean for cadmium is the mean of the logs of the cadmium observations only. A complete discussion of the data and calculations for all the metals is contained in the administrative record for this rulemaking.

Average Effluent Values

Average effluent values that form the basis for the monthly

limitations were developed in a manner consistent with the method used to develop one-day treatment effectiveness in that the lognormal distribution used for the one-day effluent values was also used as the basis for the average values. That is, we assume a number of consecutive measurements are drawn from the distribution of daily measurements. The average of ten measurements taken during a month was used as the basis for the monthly average limitations. The approach used for the 10 measurement values was employed previously in regulations for other categories. That is, the distribution of the average of 10 samples from a lognormal was approximated by another lognormal distribution. Although the approximation is not precise theoretically, there is empirical evidence based on effluent data from a number of categories that the lognormal is an adequate approximation for the distribution of small samples. In the course of previous work the approximation was verified in a computer simulation study (see "Development Document for Existing Sources Pretreatment Standards for the Electroplating Point Source Category", EPA 440/1-79/003, U.S. Environmental Protection Agency, Washington, D.C., August 1979). We also note that the average values were developed assuming independence of the observations although no particular sampling scheme was assumed.

Ten-Sample Average:

The formulas for the 10-sample limitations were derived on the basis of simple relationships between the mean and variance of the distributions of the daily pollutant measurements and the average of 10 measurements. We assume the daily concentration measurements for a particular pollutant, denoted by X , follow a lognormal distribution with log mean and log variance denoted by μ and σ^2 , respectively. Let X_{10} denote the mean of 10 consecutive measurements. The following relationships then hold assuming the daily measurements are independent:

$$\text{mean of } X_{10} = E(X_{10}) = E(X)$$

$$\text{variance of } X_{10} = V(X_{10}) = V(X) \quad 10.$$

Where $E(X)$ and $V(X)$ are the mean and variance of X , respectively, defined above. We then assume that X_{10} follows a lognormal distribution with log mean μ_{10} and log standard deviation σ_{10}^2 . The mean and variance of X_{10} are then

$$E(X_{10}) = \exp(\mu_{10} + 0.5 \sigma_{10}^2)$$

$$V(X_{10}) = \exp(2\mu_{10} + \sigma_{10}^2) [\exp(\sigma_{10}^2) - 1]$$

Now, μ_{10} and σ_{10}^2 can be derived in terms of μ and σ^2 as

$$\mu_{10} = \mu + \sigma^2/2 + 0.5 \ln [1 + \exp(\sigma^2/N)]$$

$$\sigma^2_{10} = \ln [1 + (\exp(\sigma^2) - 1)/N]$$

Therefore, μ_{10} and σ^2_{10} can be estimated using the above relationships and the estimates of μ and σ^2 obtained for the underlying lognormal distribution. The 10 sample limitation value was determined by the estimate of the approximate 99th percentile of the distribution of the 10 sample average given by

$$X_{10} (.99) = \exp (\hat{\mu}_{10} + 2.33 \sigma_{10}).$$

where $\hat{\mu}_{10}$ and σ_{10} are the estimates of μ_{10} and σ_{10} respectively.

Thirty Sample Average

Monthly average values based on the average of 30 daily measurements were also calculated. These are included because monthly limitations based on 30 samples have been used in the past and for comparison with the 10 sample values. The average values based on 30 measurements are determined on the basis of a statistical result known as the Central Limit Theorem. This Theorem states that, under general and nonrestrictive assumptions, the distribution of a sum of a number of random variables, say n , is approximated by the normal distribution. The approximation improves as the number of variables, n , increases. The Theorem is quite general in that no particular distributional form is assumed for the distribution of the individual variables. In most applications (as in approximating the distribution of 30-day averages) the Theorem is used to approximate the distribution of the average of n observations of a random variable. The result makes it possible to compute approximate probability statements about the average in a wide range of cases. For instance, it is possible to compute a value below which a specified percentage (e.g., 99 percent) of the averages of n observations are likely to fall. Most textbooks state that 25 or 30 observations are sufficient for the approximation to be valid. In applying the Theorem to the distribution of the 30-day average effluent values, we approximate the distribution of the average of 30 observations drawn from the distribution of daily measurements and use the estimated 99th percentile of this distribution.

Thirty Sample Average Calculation

The formulas for the 30 sample average were based on an application of the Central Limit Theorem. According to the Theorem, the average of 30 observations drawn from the distribution of daily measurements, denoted by X_{30} , is approximately normally distributed. The mean and variance of

X30 are:

$$\text{mean of } \bar{X}_{30} = E(\bar{X}_{30}) = E(X)$$

$$\text{variance of } \bar{X}_{30} = V(\bar{X}_{30}) = V(X)/30.$$

The 30 sample average value was determined by the estimate of the approximate 99th percentile of the distribution of the 30 sample average given by

$$\bar{X}_{30}(\hat{.99}) = \hat{E}(X) = 2.33 \sqrt{V(X) / 30}$$

where

$$\hat{E}(X) = \exp(\bar{y}) \psi_n(0.5V(y))$$

$$\text{and } \hat{V}(X) = \exp(2\bar{y}) \left[\psi_n(2V(y)) - n(n-2)/(n-1) V(y) \right]$$

The formulas for $\hat{E}(X)$ and $\hat{V}(X)$ are estimates of $E(X)$ and $V(X)$, respectively, given in Aitchison, J. and J.A.C. Brown, The Lognormal Distribution, Cambridge University Press, 1963, page 45.

Application

In response to the proposed coil coating and porcelain enameling regulations, the Agency received comments pointing out that permits usually required less than 30 samples to be taken during a month while the monthly average used as the basis for permits and pretreatment requirements usually is based on the average of 30 samples.

In applying the treatment effectiveness values to regulations, we have considered the comments, examined the sampling frequency required by many permits and considered the change in values of averages depending on the number of consecutive sampling days in the averages. The most common frequency of sampling required in permits is about ten samples per month or slightly greater than twice weekly. The 99th percentiles of the distribution of averages of ten consecutive sampling days are not substantially different from the 99th percentile of the distribution's 30-day average. (Compared to the one-day maximum, the ten-day average is about 80 percent of the difference between one- and 30-day values). Hence the ten-day average provides a reasonable basis for a monthly average limitation and is typical of the sampling frequency required by existing permits.

The monthly average limitation is to be achieved in all permits and pretreatment standards regardless of the number of samples required to be analyzed and averaged by the permit or the pretreatment authority. Treatment effectiveness for the nine pollutants studied in the combined metals data base are tabulated

in Table VII-14 (page 242) and are included in Table VII-21.

Additional Pollutants

Thirty-three additional pollutant parameters were evaluated to determine the performance of lime and settle treatment systems in removing them from industrial wastewater. Performance data for these parameters are not a part of the CMDB so other available data have been used to determine the long term average performance of lime and settle technology for each pollutant. These data are displayed in Table VII-15 (page 243). Treatment effectiveness values for these additional pollutants were calculated by multiplying the mean performance from Table VII-15 by the appropriate variability factor. (The variability factor is the ratio of the value of concern to the mean). The pooled variability factors are: one-day maximum - 4.100; ten-day average 1.821; and 30-day average - 1.618. These one-, ten-, and thirty-day values are tabulated in Table VII-21 (page 248).

In establishing which data were suitable for use in Table VII-15 two factors were heavily weighed: (1) the nature of the wastewater; and (2) the range of pollutants or pollutant matrix in the raw wastewater. These data have been selected from processes that generate dissolved metals in the wastewater and which are generally free from complexing agents. The pollutant matrix was evaluated by comparing the concentrations of pollutants found in the raw wastewaters with the range of pollutants in the raw wastewaters of the combined metals data set. The raw wastewater pollutant matrix for the CMDB is shown in Table VII-16 (page 243). Table VII-17 (page 244), displays the raw waste pollutant matrix of wastewaters from which long term average treatment effectiveness data were derived for 18 of the added pollutant(s). Data for the remaining added pollutants were developed from CMDB related manufacturing facilities. The available data on these added pollutants do not allow a homogeneity analysis as was performed on the combined metals data base. Because the concentrations of the components in the raw wastewaters is similar to or less than that of the CMDB it is appropriate to logically assume transferability of the treated pollutant concentrations to the combined metals data base.

Antimony (Sb) - The achievable performance for antimony is based on data from a battery and secondary lead plant. Both EPA sampling data and recent permit data (1978-1982) confirm the achievability of 0.7 mg/l in the battery manufacturing wastewater matrix included in the combined data set. The 0.7 mg/l concentration is achieved at a nonferrous metals manufacturing and secondary lead plant with the comparable untreated wastewater matrix shown in Table VII-17 (page 244).

Arsenic (As) - The achievable performance of 0.51 mg/l for arsenic is based on permit data from two nonferrous metals

manufacturing plants. The untreated wastewater matrix shown in Table VII-17 (page 244) is comparable with the combined data set matrix.

Beryllium (Be) - The achievable performance of beryllium is from the nonferrous metals manufacturing industry. The 0.3 mg/l performance is achieved at a beryllium plant with the comparable untreated wastewater matrix shown in Table VII-17.

Mercury (Hg) - The achievable concentration of 0.06 mg/l for mercury is based on data from four battery plants. The untreated wastewater matrix at these plants was considered in the combined metals data set.

Selenium (Se) - The achievable concentration of 0.30 mg/l for selenium is based on recent permit data from one of the nonferrous metals manufacturing plants also used for arsenic performance. The untreated wastewater matrix for this plant is shown in Table VII-17.

Silver (S) - The achievable concentration of 0.1 mg/l for silver is based on an estimate from the inorganic chemicals industry. Additional data supporting a treatability as stringent or more stringent than 0.1 mg/l is also available from seven nonferrous metals manufacturing plants. The untreated wastewater matrix for these plants is comparable and summarized in Table VII-17.

Thallium (Tl) The 0.50 mg/l treatability for thallium is transferred from the inorganic chemicals industry. Although no untreated wastewater data are available to verify comparability with the combined metals data set plants, no other sources of data for thallium treatability could be identified.

Aluminum (Al) - The 2.24 mg/l achievable concentration of aluminum is based on the mean performance of three aluminum forming plants and one coil coating plant. These plants are from categories included in the combined metals data set, assuring untreated wastewater matrix comparability.

Barium (Ba) - The achievable performance for barium (0.42 mg/l) is based on data from one nonferrous metals forming plant. The untreated wastewater matrix shown in Table VII-17 is comparable with the combined metals data base.

Boron (B) - The achievable performance of 0.36 mg/l for boron is based on data from a nonferrous metals plant. The untreated wastewater matrix shown in Table VII-17 is comparable with the combined metals data base.

Cesium (Cs) - The achievable performance for cesium (0.124 mg/l) is based on the performance achievable for sodium using ion exchange technology. This transfer of performance is technically justifiable because of the similarity of the chemical and physical behavior of these monovalent atoms.

Cobalt (Co) - The 0.05 mg/l achievable concentration is based on nearly complete removal of cobalt at a porcelain enameling plant with a mean untreated wastewater cobalt concentration of 4.31 mg/l. In this case, the analytical detection limit using aspiration techniques for this pollutant is used as the basis of the treatability. Porcelain enameling was considered in the combined metals data base, assuring untreated wastewater matrix comparability.

Columbium (Nb) - Data collected at two refractory metals forming plants indicate that lime and settle reduces columbium to below the level of detection (using x-ray fluorescence analytical methods) when an operating pH of eight is maintained. Another sampled lime and settle treatment system is operated at a higher pH, from 10.5 to 11.5. Effluent concentrations of columbium from this system are significantly higher. Therefore, the data indicate that if the treatment system is operated at a pH near 8, columbium should be removed to below the level of detection. The level of detection (0.12 mg/l) is used as the one-day maximum concentration for lime and settle treatment effectiveness values are established since it is impossible to determine precisely what concentrations are achievable. The untreated wastewater matrix shown in Table VII-17 (page 244) is comparable with the combined metals data base.

Fluoride (F) - The 14.5 mg/l treatability of fluoride generally applicable to metals processing is based on the mean performance (47 samples) from two electronics manufacturing phase II plants. The untreated wastewater matrix for this plant shown in Table VII-17 is comparable to the combined metals data set.

Gallium (Ga) - The achievable concentration of gallium is assumed to be the same as the level for chromium (0.084 mg/l) for the reasons discussed below for indium.

Germanium (Ge) - The achievable concentration of germanium is assumed to be the same as the level for chromium (0.084 mg/l) for the reasons discussed for indium (see below).

Gold (Au). The treatment effectiveness value for gold (0.1 mg/l) is based on the performance achieved at a secondary precious metals manufacturing facility whose treatment scheme includes lime, settle, filter and ion exchange. This value is supported by data obtained from an ion exchange equipment manufacturer (Rohm & Haas) for treatment of electroplating rinse water.

Hafnium (Hf) - The achievable performance for hafnium (7.28 mg/l) is based on the performance achieved for zirconium at two nonferrous metals forming plants. The Agency believes that since the water chemistry for zirconium and hafnium is similar, hafnium can be removed to the same levels as zirconium.

Indium (In) - The achievable concentration for indium is assumed to be the same as the level for chromium (0.084 mg/l).

Lacking any treated effluent data for indium, a comparison was made between the theoretical solubilities of indium and the metals in the Combined Metals Data Base: cadmium, chromium, copper, lead, nickel and zinc. The theoretical solubility of indium (2.5×10^{-7}) is more similar to the theoretical solubility of chromium (1.65×10^{-8}) than it is to the theoretical solubilities of cadmium, copper, lead, nickel or zinc. The theoretical solubilities of these metals range from 20×10^{-3} to 2.2×10^{-5} mg/l. This comparison is further supported by the fact that indium and chromium both form hydroxides in the trivalent state. Cadmium, copper, lead, nickel and zinc all form divalent hydroxides.

Molybdenum (Mo) - The 1.83 mg/l treatment effectiveness is based on data from a nonferrous metals manufacturing and forming plant which uses coprecipitation of molybdenum with iron. The treatment effectiveness concentration of 1.83 mg/l is achievable with iron coprecipitation and lime and settle treatment. The untreated wastewater matrix shown in Table VII-17 (page 244) is comparable with the combined metals data base.

Palladium (Pd) - The treatment effectiveness value for palladium (0.1 mg/l) is based on the performance achieved at a secondary precious metals manufacturing facility whose treatment scheme includes lime, settle, filter and ion exchange. This value is supported by data obtained from an ion exchange equipment manufacturer (Rohm & Haas) for treatment of electroplating rinse water.

Phosphorus (P) - The 4.08 mg/l achievable concentration of phosphorus is based on the mean of 44 samples including 19 samples from the Combined Metals Data Base and 25 samples from the electroplating data base. Inclusion of electroplating data with the combined metals data was considered appropriate, since the removal mechanism for phosphorus is a precipitation reaction with calcium rather than hydroxide.

Platinum (Pt) - The treatment effectiveness value for platinum (0.1 mg/l) is based on the performance achieved at a secondary precious metals manufacturing facility whose treatment scheme includes lime, settle, filter and ion exchange. This value is supported by data obtained from an ion exchange equipment manufacturer (Rohm & Haas) for treatment of electroplating rinse water.

Radium 226 (Ra 226) - The achievable performance of 6.17 picocuries per liter for radium 226 is based on data from one facility in the uranium subcategory of the Ore Mining and Dressing category which practices barium chloride coprecipitation in conjunction with lime and settle treatment. The untreated wastewater matrix shown in Table VII-17 is comparable with the Combined Metals Data Base.

Rhenium (Re) - The achievable performance for rhenium (1.83 mg/l) is based on the performance achieved for molybdenum at a

nonferrous metals manufacturing and forming plant. This transfer of performance is technically justifiable because of the similarity of the physical and chemical behavior of these compounds.

Rubidium (Rb) - The achievable performance for rubidium (0.124 mg/l) is based on the performance achievable for sodium using ion exchange technology. This transfer of performance is technically justifiable because of the similarity of the chemical and physical behavior of these monivalent atoms.

Tantalum (Ta) - As with columbium, data collected at two refractory metals forming plants indicate that lime and settle reduces tantalum to below the level of detection (using x-ray fluorescence analytical methods) when an operating pH of eight is maintained. Another sampled lime and settle treatment system is operated at a higher pH, from 10.5 to 11.5. Effluent concentrations of tantalum from this system are significantly higher. Therefore, the data indicate that if the treatment system is operated at a pH near 8, tantalum should be removed to below the level of detection. The level of detection (0.45 mg/l) is used as the one-day maximum concentration for lime and settle treatment effectiveness. No long-term, 10-day, and 30-day average treatment effectiveness values are established since it is impossible to determine precisely what concentrations are achievable. The untreated wastewater matrix shown in Table VII-17 is comparable with the combined metals data base.

Tin (Sn) - The achievable performance of 0.14 mg/l for tin is based on data from one metal finishing tin plant. The untreated wastewater matrix shown in Table VII-17 is comparable with the combined metals data base.

Titanium (Ti) - The 0.19 mg/l achievable concentration is based on the mean performance of four nonferrous metals forming plants. A total of 9 samples were included in the calculation of the mean performance. The untreated wastewater matrix shown in Table VII-17 is comparable with the combined metals data base.

Tungsten (W) - The 1.29 mg/l treatability (using x-ray fluorescence analytical methods) is based on data collected from the refractory metals forming plant where an operating pH of 10.5 to 11.5 was used. The data indicate that maintaining the pH within this range achieves significantly better removal of tungsten than a pH near 8. Therefore, plants that treat wastewaters containing both tantalum and tungsten or other metals that precipitate at a higher pH may need to use a two-stage lime and settle system to remove all of these metals. The untreated wastewater matrix shown in Table VII-17 is comparable with the combined metals data base.

Uranium (U) - The achievable performance of 4.0 mg/l for uranium is based on data from one facility in the uranium

subcategory of the Ore Mining and Dressing category which practices chemical precipitation and sedimentation treatment. The untreated wastewater matrix shown in Table VII-17 (page 244) is comparable with the combined metals data base.

Vanadium (V) - Data collected at two nonferrous metals forming plants indicate that lime and settle reduces vanadium to below the detection limit. The level of detection (0.10 mg/l) is used as the one-day maximum concentration for lime and settle treatment. No long-term, 10-day or 30-day average treatment effectiveness values are established since it is impossible to determine precisely what concentrations are achievable. The untreated wastewater matrix shown in Table VII-17 is comparable with the combined metals data base.

Zirconium (Zr) - The zirconium treatment effectiveness of 7.28 mg/l is based on the mean performance of two nonferrous metals forming plants with lime and settle treatment. One plant forms zirconium and the other plant forms refractory metals. The untreated wastewater matrix shown in Table VII-17 is comparable with the combined metals data base.

Applicability of CMBD and Additional Pollutant Data Base to Plants with Elevated Raw Wastewater Concentrations

Several comments on the proposed regulations for nonferrous metals manufacturing pointed out that plants in the category had concentrated process wastewater discharges containing significantly higher concentrations of toxic metals than those observed in plants in the combined metals data base and plants used to establish treatment effectiveness concentrations for the additional pollutants. Plants with elevated cadmium, copper, lead, and zinc concentrations may apply sulfide precipitation and filtration as a polishing step following lime and settle to achieve the concentrations based on the CMDB. Plants with elevated arsenic and selenium concentrations may apply sulfide precipitation and filtration as a preliminary treatment to lime and settle to achieve the CMDB concentrations.

Lime and Settle Performance on Cathode Reprocessing Wastewater - Primary Aluminum

Treatment performance data gathered during a pilot-scale study conducted by EPA on primary aluminum wastewater demonstrated that plants operating cathode reprocessing operations and using the wastewater as makeup for potline scrubber liquor cannot achieve the performance values proposed for aluminum, antimony, nickel, and fluoride. This is due to the matrix differences resulting from cathode reprocessing. The cathode reprocessing wastewater, and subsequently the potline scrubber liquor, contain dissolved solids levels in the five to six percent range. Consequently, the Agency is promulgating effluent limitations and standards based on specific treatment effectiveness concentrations for those primary aluminum plants that operate cathode reprocessing

and commingle resulting wastewater with potline scrubber liquor. To receive these alternate limitations the plant may not dilute potline scrubber liquor blowdown or cathode reprocessing wastewater with any process or nonprocess wastewater source. If the potline scrubber blowdown is diluted with other wastewaters, the complexity of the matrix decreases and thus the concentrations of the combined metals data base (as well as the transferred aluminum, antimony and fluoride concentrations) can be achieved. The derivation of the limitations and standards for this wastewater is detailed in the primary aluminum supplement.

Cyanide Precipitation Performance in Cathode Reprocessing Wastewaters

Cyanide is present in wastewater resulting from cathode reprocessing in the primary aluminum smelting industry. Its presence is due to the use of coke and pitch in the electrolytic reduction of alumina to produce aluminum metal. Cyanide has been detected at concentrations ranging from approximately 50 to 800 mg/l in this wastewater. In general, approximately 90 percent of the cyanide is present as a complex, hexacyanoferrate.

EPA conducted bench-scale and pilot-scale studies on cathode reprocessing and cryolite recovery wastewater from a primary aluminum plant. The study was directed at examining the effectiveness of removing cyanide from this wastewater by precipitating with ferrous sulfate and ferric chloride. These treatment performance studies revealed that the performance limits for cyanide precipitation are not transferrable from coil coating to primary aluminum wastewater. The pilot study is summarized in Section VII of the primary aluminum subcategory supplement.

Treatment Effectiveness Concentrations for Fluoride in Primary Aluminum and Primary Columbium-Tantalum Subcategories

The Agency has re-evaluated lime and settle technology performance for fluoride removal. The proposed treatment performance for fluoride was transferred from electrical and electronic component manufacturing (phase I) lime and settle mean performance. However, examination of the electronics data has lead the Agency to conclude that the raw concentrations of fluoride in nonferrous metals manufacturing wastewaters more closely resemble the higher concentrations found in electrical and electronics phase II rather than phase I (49 FR 55690). Therefore, the Agency believes it is appropriate to use the mean performance and daily maximum variability developed for electronics phase II to establish treatment effectiveness for fluoride removal by lime and settle treatment.

The fluoride data from Electrical and Electronic Components - Phase II were taken from self-sampling data from two plants. There were 20 observations from one plant and 27 from the other, totaling 47. A geometrical form of the lognormal distribution, known as the delta lognormal distribution, was used to model the

data. The new long-term performance concentration of 14.5 mg/l was estimated using the mean of the distribution of effluent concentrations. The daily maximum limitation of 35 mg/l was based upon estimates of the 99th percentile of the distribution of effluent concentrations. The monthly average limitation of 20 mg/l was based on the 99th percentile of the distribution of averages of 10 samples drawn from the distribution of effluent concentrations.

LS&F Performance

Tables VII-18 and VII-19 (pages 245 and 246) show long-term data from two plants which have well operated precipitation-settling treatment followed by filtration. The wastewaters from both plants contain pollutants from metals processing and finishing operations (multi-category). Both plants reduce hexavalent chromium before neutralizing and precipitating metals with lime. A clarifier is used to remove much of the solids load and a filter is used to "polish" or complete removal of suspended solids. Plant A uses a pressure filter, while plant B uses a rapid sand filter.

Raw wastewater data was collected only occasionally at each facility and the raw wastewater data is presented as an indication of the nature of the wastewater treated. Data from plant A was received as a statistical summary and is presented as received. Raw laboratory data was collected at plant B and reviewed for spurious points and discrepancies. The method of treating the data base is discussed below under lime, settle, and filter treatment effectiveness.

Table VII-20 (page 247) shows long-term data for zinc and cadmium removal at plant C, a primary zinc smelter, which operates a LS&F system. This data represents about 4 months (103 data days) taken immediately before the smelter was closed. It has been arranged similarly to Plants A and B for comparison and use.

These data are presented to demonstrate the performance of precipitation-settling-filtration (LS&F) technology under actual operating conditions and over a long period of time.

It should be noted that the iron content of the raw wastewater of plants A and B is high while that for Plant C is low. This results, for plants A and B, in co-precipitation of toxic metals with iron. Precipitation using high-calcium lime for pH control yields the results shown above. Plant operating personnel indicate that this chemical treatment combination (sometimes with polymer assisted coagulation) generally produces better and more consistent metals removal than other combinations of sacrificial metal ions and alkalis.

The LS&F performance data presented here are based on systems that provide polishing filtration after effective L&S treatment. We have previously shown that L&S treatment is equally applicable to wastewaters from the five categories because of the

homogeneity of its raw and treated wastewaters, and other factors. Because of the similarity of the wastewaters after L&S treatment, the Agency believes these wastewaters are equally amenable to treatment using polishing filters added to the L&S treatment system. The Agency concludes that these LS&F data based in part on porcelain enameling are directly applicable to nonferrous metals manufacturing.

Analysis of Treatment System Effectiveness

Data are presented in Table VII-14 showing the mean, one-day, 10-day, and 30-day values for nine pollutants examined in the L&S combined metals data base. The pooled variability factor for seven metal pollutants (excluding cadmium because of the small number of data points) was determined and is used to estimate one-day, 10-day and 30-day values. (The variability factor is the ratio of the value of concern to the mean. The pooled variability factors are: one-day maximum - 4.100; ten-day average - 1.821; and 30-day average - 1.618.) For values not calculated from the CMDB as previously discussed, the mean value for pollutants shown in Table VII-15 were multiplied by the variability factors to compute the one, ten and 30-day values. These are tabulated in Table VII-21.

The treatment effectiveness for sulfide precipitation and filtration has been calculated similarly. Long-term average values shown in Table VII-6 (page 238) have been multiplied by the appropriate variability factor to estimate one-day maximum, and ten-day and 30-day average values. Variability factors developed in the combined metals data base were used because the raw wastewaters are identical and the treatment methods are similar as both use chemical precipitation and solids removal to control metals.

LS&F technology data are presented in Tables VII-18 and VII-19 (pages 245 and 246). These data represent two operating plants (A and B) in which the technology has been installed and operated for some years. Plant A data was received as a statistical summary and is presented without change. Plant B data was received as raw laboratory analysis data. Discussions with plant personnel indicated that operating experiments and changes in materials and reagents and occasional operating errors had occurred during the data collection period. No specific information was available on those variables. To sort out high values probably caused by methodological factors from random statistical variability, or data noise, the plant B data were analyzed. For each of four pollutants (chromium, nickel, zinc, and iron), the mean and standard deviation (sigma) were calculated for the entire data set. A data day was removed from the complete data set when any individual pollutant concentration for that day exceeded the sum of the mean plus three sigma for that pollutant. Fifty-one data days (from a total of about 1300) were eliminated by this method.

Another approach was also used as a check on the above method of

eliminating certain high values. The minimum values of raw wastewater concentrations from Plant B for the same four pollutants were compared to the total set of values for the corresponding pollutants. Any day on which the treated wastewater pollutant concentration exceeded the minimum value selected from raw wastewater concentrations for that pollutant was discarded. Forty-five days of data were eliminated by that procedure. Forty-three days of data in common were eliminated by either procedures. Since common engineering practice (mean plus 3 sigma) and logic (treated wastewater concentrations should be less than raw wastewater concentrations) seem to coincide, the data base with the 51 spurious data days eliminated is the basis for all further analysis. Range, mean plus standard deviation and mean plus two standard deviations are shown in Tables VII-18 and VII-19 (pages 245 and 246) for Cr, Cu, Ni, Zn and Fe.

The Plant B data was separated into 1979, 1978, and total data base (six years) segments. With the statistical analysis from Plant A for 1978 and 1979 this in effect created five data sets in which there is some overlap between the individual years and total data sets from Plant B. By comparing these five parts it is apparent that they are quite similar and all appear to be from the same family of numbers. The largest mean found among the five data sets for each pollutant was selected as the long-term mean for LS&F technology and is used as the LS&F mean in Table VII-21.

Plant C data was used as a basis for cadmium removal performance and as a check on the zinc values derived from Plants A and B. The cadmium data is displayed in Table VII-20 (page 247) and is incorporated into Table VII-21 (page 248) for LS&F. The zinc data was analyzed for compliance with the 1-day and 30-day values in Table VII-21; no zinc value of the 103 data points exceeded the 1-day zinc value of 1.02 mg/l. The 103 data points were separated into blocks of 30 points and averaged. Each of the 3 full 30-day averages was less than the Table VII-21 value of 0.31 mg/l. Additionally the Plant C raw wastewater pollutant concentrations (Table VII-20) are well within the range of raw wastewater concentrations of the combined metals data base (Table VII-16), further supporting the conclusion that Plant C wastewater data is compatible with similar data from Plants A and B.

Concentration values for regulatory use are displayed in Table VII-21. Mean one-day, ten-day and 30-day values for L&S for nine pollutants were taken from Table VII-14 (page 242; the remaining L&S values were developed using the mean values in Table VII-15 and the mean variability factors discussed above.

LS&F mean values for Cd, Cr, Ni, Zn and Fe are derived from plants A, B, and C as discussed above. One-, ten- and thirty-day values are derived by applying the variability factor developed from the pooled data base for the specific pollutant to the mean for that pollutant. Other LS&F values are calculated using the long-term average or mean and the appropriate variability

factors.

Copper levels achieved at Plants A and B may be lower than generally achievable because of the high iron content and low copper content of the raw wastewaters. Therefore, the mean concentration value from plants A and B achieved is not used; the LS&F mean for copper is derived from the L&S technology.

L&S cyanide mean levels shown in Table VII-8 (page 239) are converted to one-day, ten-day and 30-day values using mean variability factors. LS&F mean cyanide is calculated by applying the ratios of removals L&S and LS&F as discussed previously for LS&F metals limitations. The treatment method used here is cyanide precipitation. Because cyanide precipitation is limited by the same physical processes as the metal precipitation, it is expected that the variabilities will be similar. Therefore, the average of the metal variability factors has been used as a basis for calculating the cyanide one-day, ten-day and thirty-day average treatment effectiveness values.

The filter performance for removing TSS as shown in Table VII-9 (page 240) yields a mean effluent concentration of 2.61 mg/l and corresponds to a 10-day average of 4.33, 30-day average of 3.36 mg/l and a one-day maximum of 8.88. These calculated values more than amply support the classic thirty-day and one-day values of 10 mg/l and 15 mg/l, respectively, which are used for LS&F.

Although iron concentrations were decreased in some LS&F operations, some facilities using that treatment introduce iron compounds to aid settling. Therefore, the one-day, ten-day and 30-day values for iron at LS&F were held at the L&S level so as to not unduly penalize the operations which use the relatively less objectionable iron compounds to enhance removals of toxic metals.

The removal of additional fluoride by adding polishing filtration is suspect because lime and settle technology removes calcium fluoride to a concentration near its solubility. The one available data point appears to question the ability of filters to achieve high removals of additional fluoride. The fluoride concentrations demonstrated for L&S are used as the treatment effectiveness for LS&F.

MINOR TECHNOLOGIES

Several other treatment technologies were considered for possible application in this subcategory. These technologies are presented here.

8. Carbon Adsorption

The use of activated carbon to remove dissolved organics from water and wastewater is a long demonstrated technology. It is

one of the most efficient organic removal processes available. This sorption process is reversible, allowing activated carbon to be regenerated for reuse by the application of heat and steam or solvent. Activated carbon has also proved to be an effective adsorbent for many toxic metals, including mercury. Regeneration of carbon which has adsorbed significant metals, however, may be difficult.

The term activated carbon applies to any amorphous form of carbon that has been specially treated to give high adsorption capacities. Typical raw materials include coal, wood, coconut shells, petroleum base residues, and char from sewage sludge pyrolysis. A carefully controlled process of dehydration, carbonization, and oxidation yields a product which is called activated carbon. This material has a high capacity for adsorption due primarily to the large surface area available for adsorption, 500 to 1500 m²/sq m resulting from a large number of internal pores. Pore sizes generally range from 10 to 100 angstroms in radius.

Activated carbon removes contaminants from water by the process of adsorption, or the attraction and accumulation of one substance on the surface of another. Activated carbon preferentially adsorbs organic compounds and, because of this selectivity, is particularly effective in removing organic compounds from aqueous solution.

Carbon adsorption requires pretreatment to remove excess suspended solids, oils, and greases. Suspended solids in the influent should be less than 50 mg/l to minimize backwash requirements; a downflow carbon bed can handle much higher levels (up to 2000 mg/l) but requires frequent backwashing. Backwashing more than two or three times a day is not desirable; at 50 mg/l suspended solids, one backwash will suffice. Oil and grease should be less than about 10 mg/l. A high level of dissolved inorganic material in the influent may cause problems with thermal carbon reactivation (i.e., scaling and loss of activity) unless appropriate preventive steps are taken. Such steps might include pH control, softening, or the use of an acid wash on the carbon prior to reactivation.

Activated carbon is available in both powdered and granular form. An adsorption column packed with granular activated carbon is shown in Figure VII-17 (page 270). Powdered carbon is less expensive per unit weight and may have slightly higher adsorption capacity, but it is more difficult to handle and to regenerate.

Application and Performance. Carbon adsorption is used to remove mercury from wastewaters. The removal rate is influenced by the mercury level in the influent to the adsorption unit. In Table VII-24, removal levels found at three manufacturing facilities are listed.

In the aggregate these data indicate that very low effluent levels could be attained from any raw waste by use of multiple

adsorption stages. This is characteristic of adsorption processes.

Isotherm tests have indicated that activated carbon is very effective in adsorbing 65 percent of the organic priority pollutants and is reasonably effective for another 22 percent. Specifically, for the organics of particular interest, activated carbon was very effective in removing 2,4-dimethylphenol, fluoranthene, isophorone, naphthalene, all phthalates, and phenanthrene. It was reasonably effective on 1,1,1-trichloroethane, 1,1-dichloroethane, phenol, and toluene. Table VII-22 (page 249) summarizes the treatment effectiveness for most of the organic priority pollutants by activated carbon as compiled by EPA. Table VII-23 (page 250) summarizes classes of organic compounds together with examples of organics that are readily adsorbed on carbon.

In response to comments from companies in the primary aluminum subcategory on the proposed mass limitations for benzo(a)pyrene, the Agency conducted bench and pilot-scale tests on potline scrubber liquor to determine the effectiveness of various wastewater treatment technologies, including carbon adsorption, in removing polynuclear aromatic hydrocarbons (PAH) from these wastewaters. The study is discussed in greater detail in Section VII of the primary aluminum subcategory supplement and in the record supporting this rulemaking.

The pilot tests demonstrated that activated carbon will reduce the polynuclear aromatic hydrocarbons to the nominal quantification limit of 0.010 mg/l.

Advantages and Limitations. The major benefits of carbon treatment include applicability to a wide variety of organics and high removal efficiency. Inorganics such as cyanide, chromium, and mercury are also removed effectively. Variations in concentration and flow rate are well tolerated. The system is compact, and recovery of adsorbed materials is sometimes practical. However, destruction of adsorbed compounds often occurs during thermal regeneration. If carbon cannot be thermally desorbed, it must be disposed of along with any adsorbed pollutants. The capital and operating costs of thermal regeneration are relatively high. Cost surveys show that thermal regeneration is generally economical when carbon use exceeds about 1,000 lb/day. Carbon cannot remove low molecular weight or highly soluble organics. It also has a low tolerance for suspended solids, which must be removed to at least 50 mg/l in the influent water.

Operational Factors. Reliability: This system should be very reliable with upstream protection and proper operation and maintenance procedures.

Maintainability: This system requires periodic regeneration or replacement of spent carbon and is dependent upon raw waste load and process efficiency.

Solid Waste Aspects: Solid waste from this process is contaminated activated carbon that requires disposal. Carbon undergoes regeneration, which reduces the solid waste problem by reducing the frequency of carbon replacement.

Demonstration Status. Carbon adsorption systems have been demonstrated to be practical and economical in reducing COD, BOD, and related parameters in secondary municipal and industrial wastewaters; in removing toxic or refractory organics from isolated industrial wastewaters; in removing and recovering certain organics from wastewaters; and in removing and some times recovering selected inorganic chemicals from aqueous wastes. Carbon adsorption is a viable and economic process for organic waste streams containing up to 1 to 5 percent of refractory or toxic organics. Its applicability for removal of inorganics such as metals has also been demonstrated.

9. Centrifugation

Centrifugation is the application of centrifugal force to separate solids and liquids in a liquid-solid mixture or to effect concentration of the solids. The application of centrifugal force is effective because of the density differential normally found between the insoluble solids and the liquid in which they are contained. As a waste treatment procedure, centrifugation is applied to dewatering of sludges. One type of centrifuge is shown in Figure VII-18 (page 271).

There are three common types of centrifuges; disc, basket, and conveyer. All three operate by removing solids under the influence of centrifugal force. The fundamental difference among the three types is the method by which solids are collected in and discharged from the bowl.

In the disc centrifuge, the sludge feed is distributed between narrow channels that are present as spaces between stacked conical discs. Suspended particles are collected and discharged continuously through small orifices in the bowl wall. The clarified effluent is discharged through an overflow weir.

A second type of centrifuge which is useful in dewatering sludges is the basket centrifuge. In this type of centrifuge, sludge feed is introduced at the bottom of the basket, and solids collect at the bowl wall while clarified effluent overflows the lip ring at the top. Since the basket centrifuge does not have provision for continuous discharge of collected cake, operation requires interruption of the feed for cake discharge for a minute or two in a 10 to 30 minute overall cycle.

The third type of centrifuge commonly used in sludge dewatering is the conveyer type. Sludge is fed through a stationary feed pipe into a rotating bowl in which the solids are settled out against the bowl wall by centrifugal force. From the bowl wall, the solids are moved by a screw to the end of the machine, at

which point they are discharged. The liquid effluent is discharged through ports after passing the length of the bowl under centrifugal force.

Application And Performance. Virtually all industrial waste treatment systems producing sludge can use centrifugation to dewater it. Centrifugation is currently being used by a wide range of industrial concerns.

The performance of sludge dewatering by centrifugation depends on the feed rate, the rotational velocity of the drum, and the sludge composition and concentration. Assuming proper design and operation, the solids content of the sludge can be increased to 20 to 35 percent.

Advantages And Limitations. Sludge dewatering centrifuges have minimal space requirements and show a high degree of effluent clarification. The operation is simple, clean, and relatively inexpensive. The area required for a centrifuge system installation is less than that required for a filter system or sludge drying bed of equal capacity, and the initial cost is lower.

Centrifuges have a high power cost that partially offsets the low initial cost. Special consideration must also be given to providing sturdy foundations and soundproofing because of the vibration and noise that result from centrifuge operation. Adequate electrical power must also be provided since large motors are required. The major difficulty encountered in the operation of centrifuges has been the disposal of the concentrate which is relatively high in suspended, non-settling solids.

Operational Factors. Reliability: Centrifugation is highly reliable with proper control of factors such as sludge feed, consistency, and temperature. Pretreatment such as grit removal and coagulant addition may be necessary, depending on the composition of the sludge and on the type of centrifuge employed.

Maintainability: Maintenance consists of periodic lubrication, cleaning, and inspection. The frequency and degree of inspection required varies depending on the type of sludge solids being dewatered and the maintenance service conditions. If the sludge is abrasive, it is recommended that the first inspection of the rotating assembly be made after approximately 1,000 hours of operation. If the sludge is not abrasive or corrosive, then the initial inspection might be delayed. Centrifuges not equipped with a continuous sludge discharge system require periodic shutdowns for manual sludge cake removal.

Solid Waste Aspects: Sludge dewatered in the centrifugation process may be disposed of by landfill. The clarified effluent (centrate), if high in dissolved or suspended solids, may require further treatment prior to discharge.

Demonstration Status. Centrifugation is currently used in a

great many commercial applications to dewater sludge. Work is underway to improve the efficiency, increase the capacity, and lower the costs associated with centrifugation.

10. Coalescing

The basic principle of coalescence involves the preferential wetting of a coalescing medium by oil droplets which accumulate on the medium and then rise to the surface of the solution as they combine to form larger particles. The most important requirements for coalescing media are wettability for oil and large surface area. Monofilament line is sometimes used as a coalescing medium.

Coalescing stages may be integrated with a wide variety of gravity oil separation devices, and some systems may incorporate several coalescing stages. In general, a preliminary oil skimming step is desirable to avoid overloading the coalescer.

One commercially marketed system for oily waste treatment combines coalescing with inclined plate separation and filtration. In this system, the oily wastes flow into an inclined plate settler. This unit consists of a stack of inclined baffle plates in a cylindrical container with an oil collection chamber at the top. The oil droplets rise and impinge upon the undersides of the plates. They then migrate upward to a guide rib which directs the oil to the oil collection chamber, from which oil is discharged for reuse or disposal.

The oily water continues on through another cylinder containing replaceable filter cartridges, which remove suspended particles from the waste. From there the wastewater enters a final cylinder in which the coalescing material is housed. As the oily water passes through the many small, irregular, continuous passages in the coalescing material, the oil droplets coalesce and rise to an oil collection chamber.

Application and Performance. Coalescing is used to treat oily wastes which do not separate readily in simple gravity systems. The three-stage system described above has achieved effluent concentrations of 10 to 15 mg/l oil and grease from raw waste concentrations of 1000 mg/l or more.

Advantages and Limitations. Coalescing allows removal of oil droplets too finely dispersed for conventional gravity separation-skimming technology. It also can significantly reduce the residence times (and therefore separator volumes) required to achieve separation of oil from some wastes. Because of its simplicity, coalescing provides generally high reliability and low capital and operating costs. Coalescing is not generally effective in removing soluble or chemically stabilized emulsified oils. To avoid plugging, coalescers must be protected by pretreatment from very high concentrations of free oil and grease and suspended solids. Frequent replacement of prefilters may be necessary when raw waste oil concentrations are high.

Operational Factors. Reliability: Coalescing is inherently highly reliable since there are no moving parts, and the coalescing substrate (monofilament, etc.) is inert in the process and therefore not subject to frequent regeneration or replacement requirements. Large loads or inadequate pretreatment, however, may result in plugging or bypass of coalescing stages.

Maintainability: Maintenance requirements are generally limited to replacement of the coalescing medium on an infrequent basis.

Solid Waste Aspects: No appreciable solid waste is generated by this process.

Demonstration Status. Coalescing has been fully demonstrated in industries generating oily wastewater, although none are currently in use at any nonferrous metals manufacturing facilities.

11. Cyanide Oxidation by Chlorine

Cyanide oxidation using chlorine is widely used in industrial waste treatment to oxidize cyanide. Chlorine can be utilized in either the elemental or hypochlorite forms. This classic procedure can be illustrated by the following two step chemical reaction:

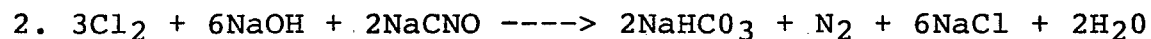
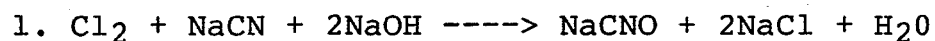

The reaction presented as Equation 2 for the oxidation of cyanate is the final step in the oxidation of cyanide. A complete system for the alkaline chlorination of cyanide is shown in Figure VII-19 (page 272).

The alkaline chlorination process oxidizes cyanides to carbon dioxide and nitrogen. The equipment often consists of an equalization tank followed by two reaction tanks, although the reaction can be carried out in a single tank. Each tank has an electronic recorder-controller to maintain required conditions with respect to pH and oxidation reduction potential (ORP). In the first reaction tank, conditions are adjusted to oxidize cyanides to cyanates. To effect the reaction, chlorine is metered to the reaction tank as required to maintain the ORP in the range of 350 to 400 millivolts, and 50 percent aqueous caustic soda is added to maintain a pH range of 9.5 to 10. In the second reaction tank, conditions are maintained to oxidize cyanate to carbon dioxide and nitrogen. The desirable ORP and pH for this reaction are 600 millivolts and a pH of 8.0. Each of

the reaction tanks is equipped with a propeller agitator designed to provide approximately one turnover per minute. Treatment by the batch process is accomplished by using two tanks, one for collection of water over a specified time period, and one for the treatment of an accumulated batch. If dumps of concentrated wastes are frequent, another tank may be required to equalize the flow to the treatment tank. When the holding tank is full, the liquid is transferred to the reaction tank for treatment. After treatment, the supernatant is discharged and the sludges are collected for removal and ultimate disposal.

Application and Performance. The oxidation of cyanide waste by chlorine is a classic process and is found in most industrial plants using cyanide. This process is capable of achieving effluent levels that are nondetectable.

Advantages and Limitations. Some advantages of chlorine oxidation for handling process effluents are operation at ambient temperature, suitability for automatic control, and low cost. Disadvantages include the need for careful pH control, possible chemical interference in the treatment of mixed wastes, and the potential hazard of storing and handling chlorine gas.

Operational Factors. Reliability: Chlorine oxidation is highly reliable with proper monitoring and control and proper pretreatment to control interfering substances.

Maintainability: Maintenance consists of periodic removal of sludge and recalibration of instruments.

Solid Waste Aspects: There is no solid waste problem associated with chlorine oxidation.

Demonstration Status. The oxidation of cyanide wastes by chlorine is a widely used process in plants using cyanide in cleaning and metal processing baths. Alkaline chlorination is also used for cyanide treatment in a number of inorganic chemical facilities producing hydrocyanic acid and various metal cyanides.

12. Cyanide Oxidation By Ozone

Ozone is a highly reactive oxidizing agent which is approximately ten times more soluble than oxygen on a weight basis in water. Ozone may be produced by several methods, but the silent electrical discharge method is predominant in the field. The silent electrical discharge process produces ozone by passing oxygen or air between electrodes separated by an insulating material. A complete ozonation system is represented in Figure VII-20 (page 273).

Application and Performance. Ozonation has been applied commercially to oxidize cyanides, phenolic chemicals, and organometal complexes. Its applicability to photographic wastewaters has been studied in the laboratory with good results. Ozone is used in industrial waste treatment primarily

to oxidize cyanide to cyanate and to oxidize phenols and dyes to a variety of colorless nontoxic products.

Oxidation of cyanide to cyanate is illustrated below:

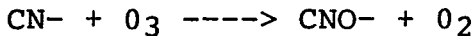

Continued exposure to ozone will convert the cyanate formed to carbon dioxide and ammonia; however, this is not economically practical.

Ozone oxidation of cyanide to cyanate requires 1.8 to 2.0 pounds ozone per pound of CN^- ; complete oxidation requires 4.6 to 5.0 pounds ozone per pound of CN^- . Zinc, copper, and nickel cyanides are easily destroyed to a nondetectable level, but cobalt and iron cyanides are more resistant to ozone treatment.

Advantages and Limitations. Some advantages of ozone oxidation for handling process effluents are its suitability to automatic control and on-site generation and the fact that reaction products are not chlorinated organics and no dissolved solids are added in the treatment step. Ozone in the presence of activated carbon, ultraviolet, and other promoters shows promise of reducing reaction time and improving ozone utilization, but the process at present is limited by high capital expense, possible chemical interference in the treatment of mixed wastes, and an energy requirement of 25 kwh/kg of ozone generated. Cyanide is not economically oxidized beyond the cyanate form.

Operational Factors. Reliability: Ozone oxidation is highly reliable with proper monitoring and control, and proper pretreatment to control interfering substances.

Maintainability: Maintenance consists of periodic removal of sludge, and periodic renewal of filters and desiccators required for the input of clean dry air; filter life is a function of input concentrations of detrimental constituents.

Solid Waste Aspects: Pretreatment to eliminate substances which will interfere with the process may be necessary. Dewatering of sludge generated in the ozone oxidation process or in an "in line" process may be desirable prior to disposal.

13. Cyanide Oxidation By Ozone With UV Radiation

One of the modifications of the ozonation process is the simultaneous application of ultraviolet light and ozone for the treatment of wastewater, including treatment of halogenated organics. The combined action of these two forms produces reactions by photolysis, photosensitization, hydroxylation, oxygenation, and oxidation. The process is unique because several reactions and reaction species are active simultaneously.

Ozonation is facilitated by ultraviolet absorption because both

the ozone and the reactant molecules are raised to a higher energy state so that they react more rapidly. In addition, free radicals for use in the reaction are readily hydrolyzed by the water present. The energy and reaction intermediates created by the introduction of both ultraviolet and ozone greatly reduce the amount of ozone required compared with a system using ozone alone. Figure VII-21 (page 274) shows a three-stage UV-ozone system. A system to treat mixed cyanides requires pretreatment that involves chemical coagulation, sedimentation, clarification, equalization, and pH adjustment.

Application and Performance. The ozone-UV radiation process was developed primarily for cyanide treatment in the electroplating and color photo-processing areas. It has been successfully applied to mixed cyanides and organics from organic chemicals manufacturing processes. The process is particularly useful for treatment of complexed cyanides such as ferricyanide, copper cyanide, and nickel cyanide, which are resistant to ozone alone.

14. Cyanide Oxidation By Hydrogen Peroxide

Hydrogen peroxide oxidation removes both cyanide and metals in cyanide containing wastewaters. In this process, cyanide bearing waters are heated to 49 to 54° C (120 to 130°F) and the pH is adjusted to 10.5 to 11.8. Formalin (37 percent formaldehyde) is added while the tank is vigorously agitated. After 2 to 5 minutes, a proprietary peroxygen compound (41 percent hydrogen peroxide with a catalyst and additives) is added. After an hour of mixing, the reaction is complete. The cyanide is converted to cyanate, and the metals are precipitated as oxides or hydroxides. The metals are then removed from solution by either settling or filtration.

The main equipment required for this process is two holding tanks equipped with heaters and air spargers or mechanical stirrers. These tanks may be used in a batch or continuous fashion, with one tank being used for treatment while the other is being filled. A settling tank or a filter is needed to concentrate the precipitate.

Application and Performance. The hydrogen peroxide oxidation process is applicable to cyanide-bearing wastewaters, especially those containing metal-cyanide complexes. In terms of waste reduction performance, this process can reduce total cyanide to less than 0.1 mg/l and the zinc or cadmium to less than 1.0 mg/l.

Advantages and Limitations. Chemical costs are similar to those for alkaline chlorination using chlorine and lower than those for treatment with hypochlorite. All free cyanide reacts and is completely oxidized to the less toxic cyanate state. In addition, the metals precipitate and settle quickly, and they may be recoverable in many instances. However, the process requires energy expenditures to heat the wastewater prior to treatment.

Demonstration Status. This treatment process was introduced in

1971 and is used in several facilities. No nonferrous metals manufacturing plants are known to use oxidation by hydrogen peroxide.

15. Evaporation

Evaporation is a concentration process. Water is evaporated from a solution, increasing the concentration of solute in the remaining solution. If the resulting water vapor is condensed back to liquid water, the evaporation-condensation process is called distillation. However, to be consistent with industry terminology, evaporation is used in this report to describe both processes. Both atmospheric and vacuum evaporation are commonly used in industry today. Specific evaporation techniques are shown in Figure VII-22 (page 275) and discussed below.

Atmospheric evaporation could be accomplished simply by boiling the liquid. However, to aid evaporation, heated liquid is sprayed on an evaporation surface, and air is blown over the surface and subsequently released to the atmosphere. Thus, evaporation occurs by humidification of the air stream, similar to a drying process. Equipment for carrying out atmospheric evaporation is quite similar for most applications. The major element is generally a packed column with an accumulator bottom. Accumulated wastewater is pumped from the base of the column, through a heat exchanger, and back into the top of the column, where it is sprayed into the packing. At the same time, air drawn upward through the packing by a fan is heated as it contacts the hot liquid. The liquid partially vaporizes and humidifies the air stream. The fan then blows the hot, humid air to the outside atmosphere. A scrubber is often unnecessary because the packed column itself acts as a scrubber.

Another form of atmospheric evaporator also works on the air humidification principle, but the evaporated water is recovered for reuse by condensation. These air humidification techniques operate well below the boiling point of water and can utilize waste process heat to supply the energy required.

In vacuum evaporation, the evaporation pressure is lowered to cause the liquid to boil at reduced temperature. All of the water vapor is condensed, and to maintain the vacuum condition, noncondensable gases (air in particular) are removed by a vacuum pump. Vacuum evaporation may be either single or double effect. In double effect evaporation, two evaporators are used, and the water vapor from the first evaporator (which may be heated by steam) is used to supply heat to the second evaporator. As it supplies heat, the water vapor from the first evaporator condenses. Approximately equal quantities of wastewater are evaporated in each unit; thus, the double effect system evaporates twice the amount of water that a single effect system does, at nearly the same cost in energy but with added capital cost and complexity. The double effect technique is thermodynamically possible because the second evaporator is maintained at lower pressure (higher vacuum) and, therefore, lower evaporation temperature. Vacuum evaporation equipment may

be classified as submerged tube or climbing film evaporation units.

Another means of increasing energy efficiency is vapor recompression evaporation, which enables heat to be transferred from the condensing water vapor to the evaporating wastewater. Water vapor generated from incoming wastewaters flows to a vapor compressor. The compressed steam then travels through the wastewater via an enclosed tube or coil in which it condenses as heat is transferred to the surrounding solution. In this way, the compressed vapor serves as a heating medium. After condensation, this distillate is drawn off continuously as the clean water stream. The heat contained in the compressed vapor is used to heat the wastewater, and energy costs for system operation are reduced.

In the most commonly used submerged tube evaporator, the heating and condensing coil are contained in a single vessel to reduce capital cost. The vacuum in the vessel is maintained by an eductor-type pump, which creates the required vacuum by the flow of the condenser cooling water through a venturi. Wastewater accumulates in the bottom of the vessel, and it is evaporated by means of submerged steam coils. The resulting water vapor condenses as it contacts the condensing coils in the top of the vessel. The condensate then drips off the condensing coils into a collection trough that carries it out of the vessel. Concentrate is removed from the bottom of the vessel.

The major elements of the climbing film evaporator are the evaporator, separator, condenser, and vacuum pump. Wastewater is "drawn" into the system by the vacuum so that a constant liquid level is maintained in the separator. Liquid enters the steam-jacketed evaporator tubes, and part of it evaporates so that a mixture of vapor and liquid enters the separator. The design of the separator is such that the liquid is continuously circulated from the separator to the evaporator. The vapor entering the separator flows out through a mesh entrainment separator to the condenser, where it is condensed as it flows down through the condenser tubes. The condensate, along with any entrained air, is pumped out of the bottom of the condenser by a liquid ring vacuum pump. The liquid seal provided by the condensate keeps the vacuum in the system from being broken.

Application and Performance. Both atmospheric and vacuum evaporation are used in many industrial plants, mainly for the concentration and recovery of process solutions. Many of these evaporators also recover water for rinsing. Evaporation has also been applied to recovery of phosphate metal cleaning solutions.

In theory, evaporation should yield a concentrate and a deionized condensate. Actually, carry-over has resulted in condensate metal concentrations as high as 10 mg/l, although the usual level is less than 3 mg/l, pure enough for most final rinses. The condensate may also contain organic brighteners and antifoaming agents. These can be removed with an activated carbon bed, if

necessary. Samples from one plant showed 1,900 mg/l zinc in the feed, 4,570 mg/l in the concentrate, and 0.4 mg/l in the condensate. Another plant had 416 mg/l copper in the feed and 21,800 mg/l in the concentrate. Chromium analysis for that plant indicated 5,060 mg/l in the feed and 27,500 mg/l in the concentrate. Evaporators are available in a range of capacities, typically from 15 to 75 gph, and may be used in parallel arrangements for processing of higher flow rates.

Advantages and Limitations. Advantages of the evaporation process are that it permits recovery of a wide variety of process chemicals, and it is often applicable to concentration or removal of compounds which cannot be accomplished by any other means. The major disadvantage is that the evaporation process consumes relatively large amounts of energy for the evaporation of water. However, the recovery of waste heat from many industrial processes (e.g., diesel generators, incinerators, boilers and furnaces) should be considered as a source of this heat for a totally integrated evaporation system. Also, in some cases solar heating could be inexpensively and effectively applied to evaporation units. Capital costs for vapor compression evaporators are substantially higher than for other types of evaporation equipment. However, the energy costs associated with the operation of a vapor compression evaporator are significantly lower than costs of other evaporator types. For some applications, pretreatment may be required to remove solids or bacteria which tend to cause fouling in the condenser or evaporator. The build-up of scale on the evaporator surfaces reduces the heat transfer efficiency and may present a maintenance problem or increase operating cost. However, it has been demonstrated that fouling of the heat transfer surfaces can be avoided or minimized for certain dissolved solids by maintaining a seed slurry which provides preferential sites for precipitate deposition. In addition, low temperature differences in the evaporator will eliminate nucleate boiling and supersaturation effects. Steam distillable impurities in the process stream are carried over with the product water and must be handled by pre-or post treatment.

Operational Factors. Reliability: Proper maintenance will ensure a high degree of reliability for the system. Without such attention, rapid fouling or deterioration of vacuum seals may occur, especially when corrosive liquids are handled.

Maintainability: Operating parameters can be automatically controlled. Pretreatment may be required, as well as periodic cleaning of the system. Regular replacement of seals, especially in a corrosive environment, may be necessary.

Solid Waste Aspects: With only a few exceptions, the process does not generate appreciable quantities of solid waste.

Demonstration Status. Evaporation is a fully developed, commercially available wastewater treatment system. It is used

extensively to recover plating chemicals in the electroplating industry, and a pilot-scale unit has been used in connection with phosphating of aluminum. Proven performance in silver recovery indicates that evaporation could be a useful treatment operation for the photographic industry, as well as for metal finishing. Vapor compression evaporation has been practically demonstrated in a number of industries, including chemical manufacturing, food processing, pulp and paper, and metal working.

16. Flotation

Flotation is the process of causing particles such as metal hydroxides or oil to float to the surface of a tank where they can be concentrated and removed. This is accomplished by releasing gas bubbles which attach to the solid particles, increasing their buoyancy and causing them to float. In principle, this process is the opposite of sedimentation. Figure VII-23 (page 276) shows one type of flotation system.

Flotation is used primarily in the treatment of wastewater streams that carry heavy loads of finely divided suspended solids or oil. Solids having a specific gravity only slightly greater than 1.0, which would require abnormally long sedimentation times, may be removed in much less time by flotation. Dissolved air flotation is of greatest interest in removing oil from water and is less effective in removing heavier precipitates.

This process may be performed in several ways: foam, dispersed air, dissolved air, gravity, and vacuum flotation are the most commonly used techniques. Chemical additives are often used to enhance the performance of the flotation process.

The principal difference among types of flotation is the method of generating the minute gas bubbles (usually air) in a suspension of water and small particles. Chemicals may be used to improve the efficiency with any of the basic methods. The following paragraphs describe the different flotation techniques and the method of bubble generation for each process.

Froth Flotation - Froth flotation is based on differences in the physiochemical properties in various particles. Wettability and surface properties affect the particles' ability to attach themselves to gas bubbles in an aqueous medium. In froth flotation, air is blown through the solution containing flotation reagents. The particles with water repellent surfaces stick to air bubbles as they rise and are brought to the surface. A mineralized froth layer, with mineral particles attached to air bubbles, is formed. Particles of other minerals which are readily wetted by water do not stick to air bubbles and remain in suspension.

Dispersed Air Flotation - In dispersed air flotation, gas bubbles are generated by introducing the air by means of mechanical agitation with impellers or by forcing air through porous media. Dispersed air flotation is used mainly in the metallurgical

industry.

Dissolved Air Flotation - In dissolved air flotation, bubbles are produced by releasing air from a supersaturated solution under relatively high pressure. There are two types of contact between the gas bubbles and particles. The first type is predominant in the flotation of flocculated materials and involves the entrapment of rising gas bubbles in the flocculated particles as they increase in size. The bond between the bubble and particle is one of physical capture only. The second type of contact is one of adhesion. Adhesion results from the intermolecular attraction exerted at the interface between the solid particle and gaseous bubble.

Vacuum Flotation - This process consists of saturating the wastewater with air either directly in an aeration tank, or by permitting air to enter on the suction of a wastewater pump. A partial vacuum is applied, which causes the dissolved air to come out of solution as minute bubbles. The bubbles attach to solid particles and rise to the surface to form a scum blanket, which is normally removed by a skimming mechanism. Grit and other heavy solids that settle to the bottom are generally raked to a central sludge pump for removal. A typical vacuum flotation unit consists of a covered cylindrical tank in which a partial vacuum is maintained. The tank is equipped with scum and sludge removal mechanisms. The floating material is continuously swept to the tank periphery, automatically discharged into a scum trough, and removed from the unit by a pump also under partial vacuum. Auxiliary equipment includes an aeration tank for saturating the wastewater with air, a tank with a short retention time for removal of large bubbles, vacuum pumps, and sludge pumps.

Application and Performance. The primary variables for flotation design are pressure, feed solids concentration, and retention period. The suspended solids in the effluent decrease, and the concentration of solids in the float increases with increasing retention period. When the flotation process is used primarily for clarification, a retention period of 20 to 30 minutes usually is adequate for separation and concentration.

Advantages and Limitations. Some advantages of the flotation process are the high levels of solids separation achieved in many applications, the relatively low energy requirements, and the adaptability to meet the treatment requirements of different waste types. Limitations of flotation are that it often requires addition of chemicals to enhance process performance and that it generates large quantities of solid waste.

Operational Factors. Reliability: Flotation systems normally are very reliable with proper maintenance of the sludge collector mechanism and the motors and pumps used for aeration.

Maintainability: Routine maintenance is required on the pumps and motors. The sludge collector mechanism is subject to possible corrosion or breakage and may require periodic

replacement.

Solid Waste Aspects: Chemicals are commonly used to aid the flotation process by creating a surface or a structure that can easily adsorb or entrap air bubbles. Inorganic chemicals, such as the aluminum and ferric salts, and activated silica, can bind the particulate matter together and create a structure that can entrap air bubbles. Various organic chemicals can change the nature of either the air-liquid interface or the solid-liquid interface, or both. These compounds usually collect on the interface to bring about the desired changes. The added chemicals plus the particles in solution combine to form a large volume of sludge which must be further treated or properly disposed.

Demonstration Status. Flotation is a fully developed process and is readily available for the treatment of a wide variety of industrial waste streams. Flotation separation is demonstrated in one primary aluminum plant, namely, at the a smelter as a part of a system for oil removal.

17. Gravity Sludge Thickening

In the gravity thickening process, dilute sludge is fed from a primary settling tank or clarifier to a thickening tank where rakes stir the sludge gently to densify it and to push it to a central collection well. The supernatant is returned to the primary settling tank. The thickened sludge that collects on the bottom of the tank is pumped to dewatering equipment or hauled away. Figure VII-24 (page 277) shows the construction of a gravity thickener.

Application and Performance. Thickeners are generally used in facilities where the sludge is to be further dewatered by a compact mechanical device such as a vacuum filter or centrifuge. Doubling the solids content in the thickener substantially reduces capital and operating cost of the subsequent dewatering device and also reduces cost for hauling. The process is potentially applicable to almost any industrial plant.

Organic sludges from sedimentation units of one to two percent solids concentration can usually be gravity thickened to six to ten percent; chemical sludges can be thickened to four to six percent.

Advantages and Limitations. The principal advantage of a gravity sludge thickening process is that it facilitates further sludge dewatering. Other advantages are high reliability and minimum maintenance requirements.

Limitations of the sludge thickening process are its sensitivity to the flow rate through the thickener and the sludge removal rate. These rates must be low enough not to disturb the thickened sludge.

Operational Factors. Reliability: Reliability is high with proper design and operation. A gravity thickener is designed on the basis of square feet per pound of solids per day, in which the required surface area is related to the solids entering and leaving the unit. Thickener area requirements are also expressed in terms of mass loading, grams of solids per square meter per day (lbs/sq ft/day).

Maintainability: Twice a year, a thickener must be shut down for lubrication of the drive mechanisms. Occasionally, water must be pumped back through the system in order to clear sludge pipes.

Solid Waste Aspects: Thickened sludge from a gravity thickening process will usually require further dewatering prior to disposal, incineration, or drying. The clear effluent may be recirculated in part, or it may be subjected to further treatment prior to discharge.

Demonstration Status. Gravity sludge thickeners are used throughout industry to reduce water content to a level where the sludge may be efficiently handled. Further dewatering is usually practiced to minimize costs of hauling the sludge to approved landfill areas.

18. Insoluble Starch Xanthate

Insoluble starch xanthate is essentially an ion exchange medium used to remove dissolved heavy metals from wastewater. The water may then either be reused (recovery application) or discharged (end-of-pipe application). In a commercial electroplating operation, starch xanthate is coated on a filter medium. Rinse water containing dragged out heavy metals is circulated through the filters and then reused for rinsing. The starch-heavy metal complex is disposed of and replaced periodically. Laboratory tests indicate that recovery of metals from the complex is feasible, with regeneration of the starch xanthate. Besides electroplating, starch xanthate is potentially applicable to any other industrial plants where dilute metal wastewater streams are generated. Its present use is limited to one electroplating plant.

19. Ion Exchange

Ion exchange is a process in which ions, held by electrostatic forces to charged functional groups on the surface of the ion exchange resin, are exchanged for ions of similar charge from the solution in which the resin is immersed. This is classified as a sorption process because the exchange occurs on the surface of the resin, and the exchanging ion must undergo a phase transfer from solution phase to solid phase. Thus, ionic contaminants in a waste stream can be exchanged for the harmless ions of the resin.

Although the precise technique may vary slightly according to the

application involved, a generalized process description follows. The wastewater stream being treated passes through a filter to remove any solids, then flows through a cation exchanger which contains the ion exchange resin. Here, metallic impurities such as copper, iron, and trivalent chromium are retained. The stream then passes through the anion exchanger and its associated resin. Hexavalent chromium, for example, is retained in this stage. If one pass does not reduce the contaminant levels sufficiently, the stream may then enter another series of exchangers. Many ion exchange systems are equipped with more than one set of exchangers for this reason. A strongly basic anion exchange resin may be used alone to remove precious metals, such as gold, palladium and platinum.

The other major portion of the ion exchange process concerns the regeneration of the resin, which now holds those impurities retained from the waste stream. An ion exchange unit with in-place regeneration is shown in Figure VII-25 (page 278). Metal ions such as nickel are removed by an acid, cation exchange resin, which is regenerated with hydrochloric or sulfuric acid, replacing the metal ion with one or more hydrogen ions. Anions such as dichromate are removed by a basic, anion exchange resin, which is regenerated with sodium hydroxide, replacing the anion with one or more hydroxyl ions. The three principal methods employed by industry for regenerating the spent resin are:

A) Replacement Service: A regeneration service replaces the spent resin with regenerated resin, and regenerates the spent resin at its own facility. The service then has the problem of treating and disposing of the spent regenerant.

B) In-Place Regeneration: Some establishments may find it less expensive to do their own regeneration. The spent resin column is shut down for perhaps an hour, and the spent resin is regenerated. This results in one or more waste streams which must be treated in an appropriate manner. Regeneration is performed as the resins require it, usually every few months.

C) Cyclic Regeneration: In this process, the regeneration of the spent resins takes place within the ion exchange unit itself in alternating cycles with the ion removal process. A regeneration frequency of twice an hour is typical. This very short cycle time permits operation with a very small quantity of resin and with fairly concentrated solutions, resulting in a very compact system. Again, this process varies according to application, but the regeneration cycle generally begins with caustic being pumped through the anion exchanger, carrying out hexavalent chromium, for example, as sodium dichromate. The sodium dichromate stream then passes through a cation exchanger, converting the sodium dichromate to chromic acid. After concentration by evaporation or other means, the chromic acid can be returned to the process line. Meanwhile, the cation exchanger is regenerated with sulfuric acid, resulting in a waste acid stream containing the metallic impurities removed earlier. Flushing the exchangers with water completes the cycle. Thus, the wastewater is purified

and, in this example, chromic acid is recovered. The ion exchangers, with newly regenerated resin, then enter the ion removal cycle again.

Application and Performance. The list of pollutants for which the ion exchange system has proved effective includes aluminum, arsenic, cadmium, chromium (hexavalent and trivalent), copper, cyanide, gold, iron, lead, manganese, nickel, palladium, platinum, selenium, silver, tin, zinc, and more. Thus, it can be applied to a wide variety of industrial concerns. Because of the heavy concentrations of metals in their wastewater, the metal finishing industries utilize ion exchange in several ways. As an end-of-pipe treatment, ion exchange is certainly feasible, but its greatest value is in recovery applications. It is commonly used as an integrated treatment to recover rinse water and process chemicals. Some electroplating facilities use ion exchange to concentrate and purify plating baths. Also, many industrial concerns, including a number of nonferrous metals manufacturing plants, use ion exchange to reduce salt concentrations in incoming water sources.

The ion exchange process may be used to remove cyanide in a ferrocyanide complex from wastewater. The process generates a concentrated stream of the complex, which may be treated using cyanide precipitation.

Ion exchange is applicable to cyanide removal when the cyanide is complexed with iron. Experimental data have shown that a specific resin (Rohm & Haas IRA-958) is very selective to the removal of iron cyanide complexes. The process described below is based on the use of this resin and upon operating data obtained from the vendor and from an actual operating ion exchange facility.

Two downflow columns are used. The columns are operated in a merry-go-round configuration (see the granular activated carbon adsorption process description in this section for a discussion on this type of operation). The regeneration step is carried out in two stages. The first step uses regeneration solution from the previous second regeneration step. The second step uses fresh regeneration solution. This is done because a large majority of the pollutant ions are eluted in the first step. The solution used in the second step yields a dilute solution of the pollutant and can be used in the first step of the next regeneration cycle. Separation of the regeneration solution in this manner results in a 50 percent savings in regeneration solution costs and a more concentrated product. The regeneration solution used is 15 percent brine (NaCl).

Unless the cyanide in the influent is already in complexed form, the wastewater must be treated to convert the free cyanide to the ferrocyanide complex.

The spent brine solution produced in the regeneration step may be disposed of as a hazardous waste or sent to cyanide

precipitation. In this module the cyanide complex is combined with more iron at low pH to produce an insoluble complex.

Ion exchange is highly efficient at recovering metal bearing solutions. Recovery of chromium, nickel, phosphate solution, and sulfuric acid from anodizing is commercial. A chromic acid recovery efficiency of 99.5 percent has been demonstrated. Typical data for purification of rinse water have been reported and are displayed in Table VII-25 (page 251). Sampling at one nonferrous metals manufacturing plant characterized influent and effluent streams for an ion exchange unit on a silver bearing waste. This system was in start-up at the time of sampling, however, and was not found to be operating effectively.

Advantages and Limitations. Ion exchange is a versatile technology applicable to a great many situations. This flexibility, along with its compact nature and performance, makes ion exchange a very effective method of wastewater treatment. However, the resins in these systems can prove to be a limiting factor. The thermal limits of the anion resins, generally in the vicinity of 60°C, could prevent its use in certain situations. Similarly, nitric acid, chromic acid, and hydrogen peroxide can all damage the resins, as will iron, manganese, and copper when present with sufficient concentrations of dissolved oxygen. Removal of a particular trace contaminant may be uneconomical because of the presence of other ionic species that are preferentially removed. The regeneration of the resins presents its own problems. The cost of the regenerative chemicals can be high. In addition, the waste streams originating from the regeneration process are extremely high in pollutant concentrations, although low in volume. These must be further processed for proper disposal.

Operational Factors. Reliability: With the exception of occasional clogging or fouling of the resins, ion exchange has proved to be a highly dependable technology.

Maintainability: Only the normal maintenance of pumps, valves, piping and other hardware used in the regeneration process is required.

Solid Waste Aspects: Few, if any, solids accumulate within the ion exchangers, and those which do appear are removed by the regeneration process. Proper prior treatment and planning can eliminate solid build-up problems altogether. The brine resulting from regeneration of the ion exchange resin must usually be treated to remove metals before discharge. This can generate solid waste.

Demonstration Status. All of the applications mentioned in this document are available for commercial use, and industry sources estimate the number of units currently in the field at well over 120. The research and development in ion exchange is focusing on improving the quality and efficiency of the resins, rather than

new applications. Work is also being done on a continuous regeneration process whereby the resins are contained on a fluidtransfusible belt. The belt passes through a compartmentalized tank with ion exchange, washing, and regeneration sections. The resins are therefore continually used and regenerated. No such system, however, has been reported beyond the pilot stage.

Ion exchange has been used to treat cyanide containing wastewater at two plants in the primary aluminum subcategory in the nonferrous metals manufacturing category.

Ion exchange has also been used to treat wastewaters from three secondary precious metals facilities in the nonferrous metals manufacturing category. These wastewaters contain gold, platinum and palladium, as well as base metals.

20. Membrane Filtration

Membrane filtration is a treatment system for removing precipitated metals from a wastewater stream. It must therefore be preceded by those treatment techniques which will properly prepare the wastewater for solids removal. Typically, a membrane filtration unit is preceded by pH adjustment or sulfide addition for precipitation of the metals. These steps are followed by the addition of a proprietary chemical reagent which causes the precipitate to be non-gelatinous, easily dewatered, and highly stable. The resulting mixture of pretreated wastewater and reagent is continuously recirculated through a filter module and back into a recirculation tank. The filter module contains tubular membranes. While the reagent-metal hydroxide precipitate mixture flows through the inside of the tubes, the water and any dissolved salts permeate the membrane. When the recirculating slurry reaches a concentration of 10 to 15 percent solids, it is pumped out of the system as sludge.

Application and Performance. Membrane filtration appears to be applicable to any wastewater or process water containing metal ions which can be precipitated using hydroxide, sulfide or carbonate precipitation. It could function as the primary treatment system, but also might find application as a polishing treatment (after precipitation and settling) to ensure continued compliance with metals limitations. Membrane filtration systems are being used in a number of industrial applications, particularly in the metal finishing area. They have also been used for toxic metals removal in the metal fabrication industry and the paper industry.

The permeate is claimed by one manufacturer to contain less than the effluent concentrations shown in Table VII-26 (page) regardless of the influent concentrations. These claims have been largely substantiated by the analysis of water samples at various plants in various industries.

In the performance predictions for this technology, pollutant

concentrations are reduced to the levels shown below in Table VII-26 (page 252) unless lower levels are present in the influent stream.

Advantages and Limitations. A major advantage of the membrane filtration system is that installations can use most of the conventional end-of-pipe systems that may already be in place. Removal efficiencies are claimed to be excellent, even with sudden variation of pollutant input rates; however, the effectiveness of the membrane filtration system can be limited by clogging of the filters. Because pH changes in the waste stream greatly intensify clogging problems, the pH must be carefully monitored and controlled. Clogging can force the shutdown of the system and may interfere with production. In addition, the relatively high capital cost of this system may limit its use.

Operational Factors. Reliability: Membrane filtration has been shown to be a very reliable system, provided that the pH is strictly controlled. Improper pH can result in the clogging of the membrane. Also, surges in the flow rate of the waste stream must be controlled in order to prevent solids from passing through the filter and into the effluent.

Maintainability: The membrane filters must be regularly monitored, and cleaned or replaced as necessary. Depending on the composition of the waste stream and its flow rate, frequent cleaning of the filters may be required. Flushing with hydrochloric acid for 6 to 24 hours will usually suffice. In addition, the routine maintenance of pumps, valves, and other plumbing is required.

Solid Waste Aspects: When the recirculating reagent-precipitate slurry reaches 10 to 15 percent solids, it is pumped out of the system. It can then be disposed of directly or it can undergo a dewatering process. Because this sludge contains toxic metals, it requires proper disposal.

Demonstration Status. There are more than 25 membrane filtration systems presently in use on metal finishing and similar wastewaters. Bench-scale and pilot-studies are being run in an attempt to expand the list of pollutants for which this system is known to be effective.

21. Peat Adsorption

Peat moss is a complex natural organic material containing lignin and cellulose as major constituents. These constituents, particularly lignin, bear polar functional groups, such as alcohols, aldehydes, ketones, acids, phenolic hydroxides, and ethers, that can be involved in chemical bonding. Because of the polar nature of the material, its adsorption of dissolved solids such as transition metals and polar organic molecules is quite high. These properties have led to the use of peat as an agent for the purification of industrial wastewater.

Peat adsorption is a "polishing" process which can achieve very low effluent concentrations for several pollutants. If the concentrations of pollutants are above 10 mg/l, then peat adsorption must be preceded by pH adjustment for metals precipitation and subsequent clarification. Pretreatment is also required for chromium wastes using ferric chloride and sodium sulfide. The wastewater is then pumped into a large metal chamber called a kier which contains a layer of peat through which the waste stream passes. The water flows to a second kier for further adsorption. The wastewater is then ready for discharge. This system may be automated or manually operated.

Application and Performance. Peat adsorption can be used in nonferrous metals manufacturing for removal of residual dissolved metals from clarifier effluent. Peat moss may be used to treat wastewaters containing heavy metals such as mercury, cadmium, zinc, copper, iron, nickel, chromium, and lead, as well as organic matter such as oil, detergents, and dyes. Peat adsorption is currently used commercially at a textile plant, a newsprint facility, and a metal reclamation operation.

Table VII-27 (page 252) contains performance figures obtained from pilot-plant studies. Peat adsorption was preceded by pH adjustment for precipitation and by clarification.

In addition, pilot plant studies have shown that chelated metal wastes, as well as the chelating agents themselves, are removed by contact with peat moss.

Advantages and Limitations. The major advantages of the system include its ability to yield low pollutant concentrations, its broad scope in terms of the pollutants eliminated, and its capacity to accept wide variations of waste water composition.

Limitations include the cost of purchasing, storing, and disposing of the peat moss; the necessity for regular replacement of the peat may lead to high operation and maintenance costs. Also, the pH adjustment must be altered according to the composition of the waste stream.

Operational Factors. Reliability: The question of long-term reliability is not yet fully answered. Although the manufacturer reports it to be a highly reliable system, operating experience is needed to verify the claim.

Maintainability: The peat moss used in this process soon exhausts its capacity to adsorb pollutants. At that time, the kiers must be opened, the peat removed, and fresh peat placed inside. Although this procedure is easily and quickly accomplished, it must be done at regular intervals, or the system's efficiency drops drastically.

Solid Waste Aspects: After removal from the kier, the spent peat must be eliminated. If incineration is used, precautions should

be taken to insure that those pollutants removed from the water are not released again in the combustion process. Presence of sulfides in the spent peat, for example, will give rise to sulfur dioxide in the fumes from burning. The presence of significant quantities of toxic heavy metals in nonferrous metals manufacturing wastewater will in general preclude incineration of peat used in treating these wastes.

Demonstration Status. Only three facilities currently use commercial adsorption systems in the United States - a textile manufacturer, a newsprint facility, and a metal reclamation firm. No data have been reported showing the use of peat adsorption in nonferrous metals manufacturing plants.

22. Reverse Osmosis

The process of osmosis involves the passage of a liquid through a semipermeable membrane from a dilute to a more concentrated solution. Reverse osmosis (RO) is an operation in which pressure is applied to the more concentrated solution, forcing the permeate to diffuse through the membrane and into the more dilute solution. This filtering action produces a concentrate and a permeate on opposite sides of the membrane. The concentrate can then be further treated or returned to the original operation for continued use, while the permeate water can be recycled for use as clean water. Figure VII-26 (page 279) depicts a reverse osmosis system.

As illustrated in Figure VII-27, (page 280), there are three basic configurations used in commercially available RO modules: tubular, spiral-wound, and hollow fiber. All of these operate on the principle described above, the major difference being their mechanical and structural design characteristics.

The tubular membrane module uses a porous tube with a cellulose acetate membrane lining. A common tubular module consists of a length of 2.5 cm (1 inch) diameter tube wound on a supporting spool and encased in a plastic shroud. Feed water is driven into the tube under pressures varying from 40 to 55 atm (600-800 psi). The permeate passes through the walls of the tube and is collected in a manifold while the concentrate is drained off at the end of the tube. A less widely used tubular RO module uses a straight tube contained in a housing, under the same operating conditions.

Spiral-wound membranes consist of a porous backing sandwiched between two cellulose acetate membrane sheets and bonded along three edges. The fourth edge of the composite sheet is attached to a large permeate collector tube. A spacer screen is then placed on top of the membrane sandwich, and the entire stack is rolled around the centrally located tubular permeate collector. The rolled up package is inserted into a pipe able to withstand the high operating pressures employed in this process, up to 55 atm (800 psi) with the spiral-wound module. When the system is operating, the pressurized product water permeates the membrane

and flows through the backing material to the central collector tube. The concentrate is drained off at the end of the container pipe and can be reprocessed or sent to further treatment facilities.

The hollow fiber membrane configuration is made up of a bundle of polyamide fibers of approximately 0.0075 cm (0.003 in.) OD and 0.0043 cm (0.0017 in.) ID. A commonly used hollow fiber module contains several hundred thousand of the fibers placed in a long tube, wrapped around a flow screen, and rolled into a spiral. The fibers are bent in a U-shape and their ends are supported by an epoxy bond. The hollow fiber unit is operated under 27 atm (400 psi), the feed water being dispersed from the center of the module through a porous distributor tube. Permeate flows through the membrane to the hollow interiors of the fibers and is collected at the ends of the fibers.

The hollow fiber and spiral-wound modules have a distinct advantage over the tubular system in that they are able to load a very large membrane surface area into a relatively small volume. However, these two membrane types are much more susceptible to fouling than the tubular system, which has a larger flow channel. This characteristic also makes the tubular membrane much easier to clean and regenerate than either the spiral-wound or hollow fiber modules. One manufacturer claims that its helical tubular module can be physically wiped clean by passing a soft porous polyurethane plug under pressure through the module.

Application and Performance. In a number of metal processing plants, the overflow from the first rinse in a countercurrent setup is directed to a reverse osmosis unit, where it is separated into two streams. The concentrated stream contains dragged out chemicals and is returned to the bath to replace the loss of solution caused by evaporation and dragout. The dilute stream (the permeate) is routed to the last rinse tank to provide water for the rinsing operation. The rinse flows from the last tank to the first tank, and the cycle is complete.

The closed-loop system described above may be supplemented by the addition of a vacuum evaporator after the RO unit in order to further reduce the volume of reverse osmosis concentrate. The evaporated vapor can be condensed and returned to the last rinse tank or sent on for further treatment.

The largest application has been for the recovery of nickel solutions. It has been shown that RO can generally be applied to most acid metal baths with a high degree of performance, providing that the membrane unit is not overtaxed. The limitations most critical here are the allowable pH range and maximum operating pressure for each particular configuration. Adequate prefiltration is also essential. Only three membrane types are readily available in commercial RO units, and their overwhelming use has been for the recovery of various acid metal baths. For the purpose of

calculating performance predictions of this technology, a rejection ratio of 98 percent is assumed for dissolved salts, with 95 percent permeate recovery.

Advantages and Limitations. The major advantage of reverse osmosis for handling process effluents is its ability to concentrate dilute solutions for recovery of salts and chemicals with low power requirements. No latent heat of vaporization or fusion is required for effecting separations; the main energy requirement is for a high pressure pump. It requires relatively little floor space for compact, high capacity units, and it exhibits good recovery and rejection rates for a number of typical process solutions. A limitation of the reverse osmosis process for treatment of process effluents is its limited temperature range for satisfactory operation. For cellulose acetate systems, the preferred limits are 18 to 30°C (65 to 85°F); higher temperatures will increase the rate of membrane hydrolysis and reduce system life, while lower temperatures will result in decreased fluxes with no damage to the membrane. Another limitation is inability to handle certain solutions. Strong oxidizing agents, strongly acidic or basic solutions, solvents, and other organic compounds can cause dissolution of the membrane. Poor rejection of some compounds such as borates and low molecular weight organics is another problem. Fouling of membranes by slightly soluble components in solution or colloids has caused failures, and fouling of membranes by feed waters with high levels of suspended solids can be a problem. A final limitation is inability to treat or achieve high concentration with some solutions. Some concentrated solutions may have initial osmotic pressures which are so high that they either exceed available operating pressures or are uneconomical to treat.

Operational Factors. Reliability: Very good reliability is achieved so long as the proper precautions are taken to minimize the chances of fouling or degrading the membrane. Sufficient testing of the waste stream prior to application of an RO system will provide the information needed to insure a successful application.

Maintainability: Membrane life is estimated to range from six months to three years, depending on the use of the system. Downtime for flushing or cleaning is on the order of two hours as often as once each week; a substantial portion of maintenance time must be spent on cleaning any prefilters installed ahead of the reverse osmosis unit.

Solid Waste Aspects: In a closed-loop system utilizing RO there is a constant recycle of concentrate and a minimal amount of solid waste. Prefiltration eliminates many solids before they reach the module and helps keep the build-up to a minimum. These solids require proper disposal.

Demonstration Status. There are presently at least one hundred reverse osmosis wastewater applications in a variety of

industries. In addition to these, there are 30 to 40 units being used to provide pure process water for several industries. Despite the many types and configurations of membranes, only the spiral-wound cellulose acetate membrane has had widespread success in commercial applications.

23. Sludge Bed Drying

As a waste treatment procedure, sludge bed drying is employed to reduce the water content of a variety of sludges to the point where they are amenable to mechanical collection and removal to landfill. These beds usually consist of 15 to 45 cm (6 to 18 in.) of sand over a 30 cm (12 in.) deep gravel drain system made up of 3 to 6 mm (1/8 to 1/4 in.) graded gravel overlying drain tiles. Figure VII-28 (page 281) shows the construction of a drying bed.

Drying beds are usually divided into sectional areas approximately 7.5 meters (25 ft) wide x 30 to 60 meters (100 to 200 ft) long. The partitions may be earth embankments, but more often are made of planks and supporting grooved posts.

To apply liquid sludge to the sand bed, a closed conduit or a pressure pipeline with valved outlets at each sand bed section is often employed. Another method of application is by means of an open channel with appropriately placed side openings which are controlled by slide gates. With either type of delivery system, a concrete splash slab should be provided to receive the falling sludge and prevent erosion of the sand surface.

Where it is necessary to dewater sludge continuously throughout the year regardless of the weather, sludge beds may be covered with a fiberglass reinforced plastic or other roof. Covered drying beds permit a greater volume of sludge drying per year in most climates because of the protection afforded from rain or snow and because of more efficient control of temperature. Depending on the climate, a combination of open and enclosed beds will provide maximum utilization of the sludge bed drying facilities.

Application and Performance. Sludge drying beds are a means of dewatering sludge from clarifiers and thickeners. They are widely used both in municipal and industrial treatment facilities.

Dewatering of sludge on sand beds occurs by two mechanisms: filtration of water through the bed and evaporation of water as a result of radiation and convection. Filtration is generally complete in one to two days and may result in solids concentrations as high as 15 to 20 percent. The rate of filtration depends on the drainability of the sludge.

The rate of air drying of sludge is related to temperature, relative humidity, and air velocity. Evaporation will proceed at a constant rate to a critical moisture content, then at a falling

rate to an equilibrium moisture content. The average evaporation rate for a sludge is about 75 percent of that from a free water surface.

Advantages and Limitations. The main advantage of sludge drying beds over other types of sludge dewatering is the relatively low cost of construction, operation, and maintenance.

Its disadvantages are the large area of land required and long drying times that depend, to a great extent, on climate and weather.

Operational Factors. Reliability: Reliability is high with favorable climactic conditions, proper bed design and care to avoid excessive or unequal sludge application. If climatic conditions in a given area are not favorable for adequate drying, a cover may be necessary.

Maintainability: Maintenance consists basically of periodic removal of the dried sludge. Sand removed from the drying bed with the sludge must be replaced and the sand layer resurfaced.

The resurfacing of sludge beds is the major expense item in sludge bed maintenance, but there are other areas which may require attention. Underdrains occasionally become clogged and have to be cleaned. Valves or sludge gates that control the flow of sludge to the beds must be kept watertight. Provision for drainage of lines in winter should be provided to prevent damage from freezing. The partitions between beds should be tight so that sludge will not flow from one compartment to another. The outer walls or banks around the beds should also be watertight.

Solid Waste Aspects: The full sludge drying bed must either be abandoned or the collected solids must be removed to a landfill. These solids contain whatever metals or other materials were settled in the clarifier. Metals will be present as hydroxides, oxides, sulfides, or other salts. They have the potential for leaching and contaminating ground water, whatever the location of the semidried solids. Thus the abandoned bed or landfill should include provision for runoff control and leachate monitoring.

Demonstration Status. Sludge beds have been in common use in both municipal and industrial facilities for many years. However, protection of ground water from contamination is not always adequate.

24. Ultrafiltration

Ultrafiltration (UF) is a process which uses semipermeable polymeric membranes to separate emulsified or colloidal materials suspended in a liquid phase by pressurizing the liquid so that it permeates the membrane. The membrane of an ultrafilter forms a molecular screen which retains molecular particles based on their differences in size, shape, and chemical structure. The membrane permits passage of solvents and lower molecular weight molecules.

At present, an ultrafilter is capable of removing materials with molecular weights in the range of 1,000 to 100,000 and particles of comparable or larger sizes.

In an ultrafiltration process, the feed solution is pumped through a tubular membrane unit. Water and some low molecular weight materials pass through the membrane under the applied pressure of 2 to 8 atm (10 to 100 psig). Emulsified oil droplets and suspended particles are retained, concentrated, and removed continuously. In contrast to ordinary filtration, retained materials are washed off the membrane filter rather than held by it. Figure VII-29 (page 282) represents the ultrafiltration process.

Application and Performance. Ultrafiltration has potential application to nonferrous metals manufacturing for separation of oils and residual solids from a variety of waste streams. In treating nonferrous metals manufacturing wastewater, its greatest applicability would be as a polishing treatment to remove residual precipitated metals after chemical precipitation and clarification. Successful commercial use, however, has been primarily for separation of emulsified oils from wastewater. Over one hundred such units now operate in the United States, treating emulsified oils from a variety of industrial processes. Capacities of currently operating units range from a few hundred gallons a week to 50,000 gallons per day. Concentration of oily emulsions to 60 percent oil or more is possible. Oil concentrates of 40 percent or more are generally suitable for incineration, and the permeate can be treated further and in some cases recycled back to the process. In this way, it is possible to eliminate contractor removal costs for oil from some oily waste streams.

The test data in Table VII-28 (page 253) indicate ultrafiltration performance (note that UF is not intended to remove dissolved solids).

The removal percentages shown are typical, but they can be influenced by pH and other conditions.

The permeate or effluent from the ultrafiltration unit is normally of a quality that can be reused in industrial applications or discharged directly. The concentrate from the ultrafiltration unit can be disposed of as any oily or solid waste.

Advantages and Limitations. Ultrafiltration is sometimes an attractive alternative to chemical treatment because of lower capital equipment, installation, and operating costs, very high oil and suspended solids removal, and little required pretreatment. It places a positive barrier between pollutants and effluent which reduces the possibility of extensive pollutant discharge due to operator error or upset in settling and skimming systems. Alkaline values in alkaline cleaning solutions can be recovered and reused in process.

A limitation of ultrafiltration for treatment of process effluents is its narrow temperature range (18°C to 30°C) for satisfactory operation. Membrane life decreases with higher temperatures, but flux increases at elevated temperatures. Therefore, surface area requirements are a function of temperature and become a tradeoff between initial costs and replacement costs for the membrane. In addition, ultrafiltration cannot handle certain solutions. Strong oxidizing agents, solvents, and other organic compounds can dissolve the membrane. Fouling is sometimes a problem, although the high velocity of the wastewater normally creates enough turbulence to keep fouling at a minimum. Large solids particles can sometimes puncture the membrane and must be removed by gravity settling or filtration prior to the ultrafiltration unit.

Operational Factors. Reliability: The reliability of an ultrafiltration system is dependent on the proper filtration, settling or other treatment of incoming waste streams to prevent damage to the membrane. Careful pilot studies should be done in each instance to determine necessary pretreatment steps and the exact membrane type to be used.

Maintainability: A limited amount of regular maintenance is required for the pumping system. In addition, membranes must be periodically changed. Maintenance associated with membrane plug-ging can be reduced by selection of a membrane with optimum physical characteristics and sufficient velocity of the waste stream. It is occasionally necessary to pass a detergent solution through the system to remove an oil and grease film which accumulates on the membrane. With proper maintenance, membrane life can be greater than twelve months.

Solid Waste Aspects: Ultrafiltration is used primarily to recover solids and liquids. It therefore eliminates solid waste problems when the solids (e.g., paint solids) can be recycled to the process. Otherwise, the stream containing solids must be treated by end-of-pipe equipment. In the most probable applications within the nonferrous metals manufacturing category, the ultrafilter would remove hydroxides or sulfides of metals which have recovery value.

Demonstration Status. The ultrafiltration process is well developed and commercially available for treatment of wastewater or recovery of certain high molecular weight liquid and solid contaminants.

25. Vacuum Filtration

In wastewater treatment plants, sludge dewatering by vacuum filtration generally uses cylindrical drum filters. These drums have a filter medium which may be cloth made of natural or synthetic fibers or a wire-mesh fabric. The drum is suspended above and dips into a vat of sludge. As the drum rotates slowly,

part of its circumference is subject to an internal vacuum that draws sludge to the filter medium. Water is drawn through the porous filter cake to a discharge port, and the dewatered sludge, loosened by compressed air, is scraped from the filter mesh. Because the dewatering of sludge on vacuum filters is relatively expensive per kilogram of water removed, the liquid sludge is frequently thickened prior to processing. A vacuum filter is shown in Figure VII-30 (page 100).

Application and Performance. Vacuum filters are frequently used both in municipal treatment plants and in a wide variety of industries. They are most commonly used in larger facilities, which may have a thickener to double the solids content of clarifier sludge before vacuum filtering.

The function of vacuum filtration is to reduce the water content of sludge, so that the solids content increases from about 5 percent to about 30 percent.

Advantages and Limitations. Although the initial cost and area requirement of the vacuum filtration system are higher than those of a centrifuge, the operating cost is lower, and no special provisions for sound and vibration protection need be made. The dewatered sludge from this process is in the form of a moist cake and can be conveniently handled.

Operational Factors. Reliability: Vacuum filter systems have proven reliable at many industrial and municipal treatment facilities. At present, the largest municipal installation is at the West Southwest wastewater treatment plant of Chicago, Illinois, where 96 large filters were installed in 1925, functioned approximately 25 years, and then were replaced with larger units. Original vacuum filters at Minneapolis-St. Paul, Minnesota, now have over 28 years of continuous service, and Chicago has some units with similar or greater service life.

Maintainability: Maintenance consists of the cleaning or replacement of the filter media, drainage grids, drainage piping, filter pans, and other parts of the equipment. Experience in a number of vacuum filter plants indicates that maintenance consumes approximately 5 to 15 percent of the total time. If carbonate buildup or other problems are unusually severe, maintenance time may be as high as 20 percent. For this reason, it is desirable to maintain one or more spare units.

If intermittent operation is used, the filter equipment should be drained and washed each time it is taken out of service. An allowance for this wash time must be made in filtering schedules.

Solid Waste Aspects: Vacuum filters generate a solid cake which is usually trucked directly to landfill. All of the metals extracted from the plant wastewater are concentrated in the filter cake as hydroxides, oxides, sulfides, or other salts.

Demonstration Status. Vacuum filtration has been widely used for

many years. It is a fully proven, conventional technology for sludge dewatering. Vacuum filtration is used in 20 nonferrous metals manufacturing plants for sludge dewatering.

26. Permanganate Oxidation

Permanganate oxidation is a chemical reaction by which wastewater pollutants can be oxidized. When the reaction is carried to completion, the by-products of the oxidation are not environmentally harmful. A large number of pollutants can be practically oxidized by permanganate, including cyanides, hydrogen sulfide, and phenol. In addition, the chemical oxygen demand (COD) and many odors in wastewaters and sludges can be significantly reduced by permanganate oxidation carried to its end point. Potassium permanganate can be added to wastewater in either dry or slurry form. The oxidation occurs optimally in the 8 to 9 pH range. As an example of the permanganate oxidation process, the following chemical equation shows the oxidation of phenol by potassium permanganate:

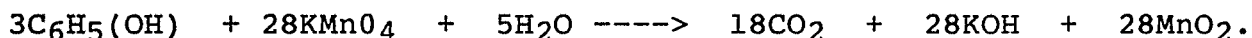

One of the by-products of this oxidation is manganese dioxide (MnO₂), which occurs as a relatively stable hydrous colloid usually having a negative charge. These properties, in addition to its large surface area, enable manganese dioxide to act as a sorbent for metal cation, thus enhancing their removal from the wastewater.

Application and Performance. Commercial use of permanganate oxidation has been primarily for the control of phenol and waste odors. Several municipal waste treatment facilities report that initial hydrogen sulfide concentrations (causing serious odor problems) as high as 100 mg/l have been reduced to zero through the application of potassium permanganate. A variety of industries (including metal finishers and agricultural chemical manufacturers) have used permanganate oxidation to totally destroy phenol in their wastewaters.

Advantages and Limitations. Permanganate oxidation has several advantages as a wastewater treatment technique. Handling and storage are facilitated by its non-toxic and non-corrosive nature. Performance has been proved in a number of municipal and industrial applications. The tendency of the manganese dioxide by-product to act as a coagulant aid is a distinct advantage over other types of chemical treatment.

The cost of permanganate oxidation treatment can be limiting where very large dosages are required to oxidize wastewater pollutants. In addition, care must be taken in storage to prevent exposure to intense heat, acids, or reducing agents; exposure could create a fire hazard or cause explosions. Of greatest concern is the environmental hazard which the use of manganese chemicals in treatment could cause. Care must be taken to remove the manganese from treated water before discharge.

Operation Factors. Reliability: Maintenance consists of periodic sludge removal and cleaning of pump feed lines. Frequency of maintenance is dependent on wastewater characteristics.

Solid Waste Aspects: Sludge is generated by the process where the manganese dioxide by-product tends to act as a coagulant aid. The sludge from permanganate oxidation can be collected and handled by standard sludge treatment and processing equipment. No nonferrous metals manufacturing facilities are known to use permanganate oxidation for wastewater treatment at this time.

Demonstration Status. The oxidation of wastewater pollutants by potassium permanganate is a proven treatment process in several types of industries. It has been shown effective in treating a wide variety of pollutants in both municipal and industrial wastes.

27. Activated Alumina Adsorption

Application, Performance, Advantages and Limitations. Activated alumina adsorbs arsenic and fluorides. Alumina's removal efficiency depends on the wastewater characteristics. High concentrations of alkalinity or chloride and high pH reduce activated alumina's capacity to adsorb. This reduction in adsorptive capacity is due to the alkalinity causing (e.g., hydroxides, carbonates, etc.) and chlorine anions competing with arsenic and fluoride ions for removal sites on the alumina.

While chemical precipitation can reduce fluoride to less than 14 mg/l by formation of calcium fluoride, activated alumina can reduce fluoride levels to below 1.0 mg/l on a long-term basis. An initial concentration of 30 mg/l of fluoride can be reduced by as much as 85 to 99+ percent. Influent arsenic concentrations of 0.3 to 10 mg/l can be reduced by 85 to 99+ percent. However, some complex forms of fluoride are not removed by activated alumina. Caustic, sulfuric acid, hydrochloric acid, and alum are used to chemically regenerate activated alumina.

Operational Factors--Reliability and Maintainability: Activated alumina has been used at potable water treatment plants for many years. Furthermore, the equipment is similar to that found in ion-exchange water softening plants which are commonly used in industry to prepare boiler water.

Demonstration Status. The use of activated alumina has not been reported by any nonferrous metals manufacturing plants nor is it widely applied in any other industrial categories. High capital and operation costs generally limit the wide application of this process in industrial applications.

28. Ammonia Stripping

Ammonia, often used as a process reagent, dissolves in water to

an extent governed by the partial pressure of the gas in contact with the liquid. The ammonia may be removed from process wastewaters by stripping with air or steam.

Air stripping takes place in a packed or lattice tower; air is blown through the packed bed or lattice, over which the ammonia-laden stream flows. Usually, the wastewater is heated prior to delivery to the tower, and air is used at ambient temperature.

The term "ammonia steam stripping" refers to the process of desorbing aqueous ammonia by contacting the liquid with a sufficient amount of ammonia-free steam. The steam is introduced countercurrent to the wastewater to maximize removal of ammonia. The operation is commonly carried out in packed bed or tray columns, and the pH is adjusted to 12 or more with lime. Simple tray designs are used in steam stripping because of the presence of appreciable suspended solids and the scaling produced by lime. These allow easy cleaning of the tower, at the expense of somewhat lower steam water contact efficiency, necessitating the use of more trays for the same removal efficiency.

Application and Performance. The evaporation of water and the volatilization of ammonia generally produces a drop in both temperature and pH, which ultimately limit the removal of ammonia in a single air stripping tower. However, high removals are favored by:

1. High pH values, which shift the equilibrium from ammonium toward free ammonia;
2. High temperature, which decreases the solubility of ammonia in aqueous solutions; and
3. Intimate and extended contact between the wastewater to be stripped and the stripping gas.

Of these factors, pH and temperature are generally more cost-effective to optimize than increasing contact time by an increase in contact tank volume or recirculation ratio. The temperature will, to some extent, be controlled by the climatic conditions; the pH of the wastewater can be adjusted to assure optimum stripping.

Steam stripping offers better ammonia removal (99 percent or better) than air stripping for high ammonia wastewaters found in the primary columbium-tantalum, primary molybdenum and rhenium, primary tungsten, secondary silver, secondary molybdenum and vanadium, primary nickel and cobalt, secondary precious metals, primary and secondary tin, secondary tungsten and cobalt, secondary uranium and primary zirconium and hafnium subcategories of this category.

The performance of an ammonia stripping column is influenced by a number of important variables that are associated with the wastewater being treated and column design. Brief discussions

of these variables follow.

Wastewater pH: Ammonia in water exists in two forms, NH_3 and NH_4^+ , the distribution of which is pH dependent. Since only the molecular form of ammonia (NH_3) can be stripped, increasing the fraction of NH_3 by increasing the pH enhances the rate of ammonia desorption.

Column Temperature: The temperature of the stripping column affects the equilibrium between gaseous and dissolved ammonia, as well as the equilibrium between the molecular and ionized forms of ammonia in water. An increase in the temperature reduces the ammonia solubility and increases the fraction of aqueous ammonia that is in the molecular form, both exhibiting favorable effects on the desorption rate.

Steam rate: The rate of ammonia transfer from the liquid to gas phase is directly proportional to the degree of ammonia undersaturation in the desorbing gas. Increasing the rate of steam supply, therefore, increases undersaturation and ammonia transfer.

Column design: A properly designed stripper column achieves uniform distribution of the feed liquid across the cross section of the column, rapid renewal of the liquid gas interface, and extended liquid-gas contacting area and time.

Chemical analysis data were collected for raw waste (treatment influent) and treated waste (treatment effluent) from one plant of the iron and steel manufacturing category. EPA collected six paired samples in a two-month period. These data are the data base for determining the effectiveness of ammonia steam stripping technology and are contained within the public record supporting this rulemaking. Ammonia treatment at this coke plant consisted of two steam stripping columns in series with steam injected countercurrently to the flow of the wastewater. A lime reactor for pH adjustment separated the two stripping columns.

An arithmetic mean of the treatment effluent data produced an ammonia long-term mean value of 32.2 mg/l. The one-day maximum, 10-day and 30-day average concentrations attainable by ammonia steam stripping were calculated using the long-term mean of the 32.2 mg/l and the variability factors developed for the combined metals data base. This produced ammonia treatment effectiveness concentrations of 133.3, 58.6, and 52.1 mg/l ammonia for the one-day maximum, 10-day and 30-day averages, respectively.

As discussed below, steam stripping is demonstrated within the nonferrous metals manufacturing category. EPA believes the performance data from the iron and steel manufacturing category provide a valid measure of this technology's performance on nonferrous category wastewater.

The Agency has verified the steam stripping performance values using steam stripping data collected at a zirconium-hafnium manufacturing plant, which is in the nonferrous category. Data collected by the plant represent almost two years of daily operations, and support the long-term mean used to establish treatment effectiveness.

The Agency also has corroborated the steam stripping performance values with data submitted by a facility manufacturing columbium and tantalum. This facility has high influent concentrations of ammonia and also high influent concentrations of dissolved solids.

Steam stripping can recover significant quantities of reagent ammonia from wastewaters containing extremely high initial ammonia concentrations, which partially offsets the capital and energy costs of the technology.

Advantages and Limitations. Strippers are widely used in industry to remove a variety of materials, including hydrogen sulfide and volatile organics as well as ammonia, from aqueous streams. The basic techniques have been applied both in process and in wastewater treatment applications and are well understood. The use of steam strippers with and without pH adjustment is standard practice for the removal of hydrogen sulfide and ammonia in the petroleum refining industry and has been studied extensively in this context. Air stripping has treated municipal and industrial wastewater and is recognized as an effective technique of broad applicability. Both air and steam stripping have successfully treated ammonia-laden wastewater, both within the nonferrous metals manufacturing category or for similar wastes in closely related industries.

The major drawback of air stripping is the low efficiency in cold weather and the possibility of freezing within the tower. Because lime may cause scaling problems and the types of towers used in air stripping are not easily cleaned, caustic soda is generally employed to raise the feed pH. Air stripping simply transfers the ammonia from one medium to another (water to air), whereas steam stripping allows for recovery and, if so desired, reuse of ammonia. Four primary tungsten plants use steam stripping to recover ammonia from process wastewater and reuse the ammonia in the manufacture of ammonium paratungstate. The two major limitations of steam strippers are the critical column design required for proper operation and the operational problems associated with fouling of the packing material.

Operational Factors. Reliability and Maintainability: Strippers are relatively easy to operate. The most complicated part of a steam stripper is the boiler. Periodic maintenance will prevent unexpected shutdowns of the boiler.

Packing fouling interferes with the intimate contacting of

liquid-gas, thus decreasing the column efficiency, and eventually leads to flooding. The stripper column is periodically taken out of service and cleaned with acid and water with air sparging. Column cutoff is predicated on a maximum allowable pressure drop across the packing of maximum "acceptable" ammonia content in the stripper bottoms. Although packing fouling may not be completely avoidable due to endothermic CaSO_4 precipitation, column runs could be prolonged by a preliminary treatment step designed to remove suspended solids originally present in the feed and those precipitated after lime addition.

Demonstration Status. Steam stripping has proved to be an efficient, reliable process for the removal of ammonia from many types of industrial wastewaters that contain high concentrations of ammonia. Industries using ammonia steam stripping technology include the fertilizer industry, iron and steel manufacturing, petroleum refining, organic chemicals manufacturing, and nonferrous metals manufacturing. Eight plants in the nonferrous metals manufacturing category currently practice steam stripping.

IN-PLANT TECHNOLOGY

The intent of in-plant technology for the nonferrous metals manufacturing point source category is to reduce or eliminate the waste load requiring end-of-pipe treatment and thereby improve the efficiency of an existing wastewater treatment system or reduce the requirements of a new treatment system. In-plant technology involves water conservation, automatic controls, good housekeeping practices, process modifications, and waste treatment.

Process Water Recycle

EPA has promulgated BAT for most subcategories based on 90 percent recycle of wet air pollution control and contact cooling wastewater. The Agency promulgated a higher rate for certain waste streams where reported rates of recycle are even higher. Water is used in wet air pollution control systems to capture particulate matter or fumes evolved during manufacturing. Cooling water is used to remove excess heat from cast metal products.

Recycle is part of the technical basis for many of the promulgated regulations in the nonferrous metals manufacturing category. The Agency identified both demonstrated and feasible recycle opportunities as early as 1973 in proposed effluent limitations for secondary aluminum.

Recycling of process water is the practice of recirculating water to be used again for the same purpose. An example of recycling process water is the return of casting contact cooling water to the casting process after the water passes through a cooling tower. Two types of recycle are possible--recycle with a bleed stream (blowdown) and total recycle. Total recycle may be

prohibited by the presence of dissolved solids. Dissolved solids (e.g., sulfates and chlorides) entering a totally recycled waste stream may precipitate, forming scale if the solubility limits of the dissolved solids are exceeded. A bleed stream may be necessary to prevent maintenance problems (pipe plugging or scaling, etc.) that would be created by the precipitation of dissolved solids. While the volume of bleed required is a function of the amount of dissolved solids in the waste stream, 10 percent bleed is a common value for a variety of process waste streams in the nonferrous metals manufacturing category. The recycle of process water is currently practiced where it is cost effective, where it is necessary due to water shortage, or where the local permitting authority has required it. Recycle, as compared to the once-through use of process water, is an effective method of conserving water.

Application and Performance. Required hardware necessary for recycle is highly site-specific. Basic items include pumps and piping. Additional materials are necessary if water treatment occurs before the water is recycled. These items will be discussed separately with each unit process. Chemicals may be necessary to control scale build-up, slime, and corrosion problems, especially with recycled cooling water.

The Agency based its zero discharge of pollutants regulation for PSES in the secondary copper subcategory on the use of cooling towers in conjunction with lime precipitation and sedimentation. The lime precipitation and sedimentation technology was included to reduce the metals concentrations so that the wastewater could be completely recycled and reused without corrosion and scaling problems. Maintenance and energy use are limited to that required by the pumps, and solid waste generation is dependent on the type of treatment system in place.

Recycling through cooling towers is the most common practice. One type of application is shown in Figure VII-31 (page 284). Casting contact cooling water is recycled through a cooling tower with a blowdown discharge.

A cooling tower is a device which cools water by bringing the water into contact with air. The water and air flows are directed in such a way as to provide maximum heat transfer. The heat is transferred to air primarily by evaporation (about 75 percent), while the remainder is removed by sensible heat transfer.

Factors influencing the rate of heat transfer and, ultimately, the temperature range of the tower, include water surface area, tower packing and configuration, air flow, and packing height. A large water surface area promotes evaporation, and sensible heat transfer rates are lower in proportion to the water surface area provided. Packing (an internal latticework contact area) is often used to produce small droplets of water which evaporate more easily, thus increasing the total surface area per unit of throughput. For a given water flow, increasing the air flow

increases the amount of heat removed by maintaining higher thermodynamic potentials. The packing height in the tower should be high enough so that the air leaving the tower is close to saturation.

A mechanical-draft cooling tower consists of the following major components: (1) Inlet-water distributor (2) Packing (3) Air fans (4) Inlet-air louvers (5) Drift or carry-over eliminators (6) Cooled water storage basin.

Advantages and Limitations. Recycle offers economic as well as environmental advantages. Water consumption is reduced and wastewater handling facilities (pumps, pipes, clarifiers, etc.) can thus be sized for smaller flows. By concentrating the pollutants in a much smaller volume (the bleed stream), greater removal efficiencies can be attained by any applied treatment technologies. Recycle may require some treatment such as sedimentation or cooling of water before it is reused.

The ultimate benefit of recycling process water is the reduction in total wastewater discharge and the associated advantages of lower flow streams. A potential problem is the build-up of dissolved solids which could result in scaling. Scaling can usually be controlled by depressing the pH and increasing the bleed flow.

Operational Factors. Reliability and Maintainability: Although the principal construction material in mechanical-draft towers is wood, other materials are used extensively. For long life and minimum maintenance, wood is generally pressure-treated with a preservative. Although the tower structure is usually made of treated redwood, a reasonable amount of treated fir has been used in recent years. Sheathing and louvers are generally made of asbestos cement, and the fan stacks of fiberglass. There is a trend to use fire-resistant extracted PVC as fill which, at little or no increase in cost, offers the advantage of permanent fire-resistant properties.

The major disadvantages of wood are its susceptibility to decay and fire. Steel construction is occasionally used, but not to any great extent. Concrete may be used but has relatively high construction labor costs, although it does offer the advantage of fire protection.

Various chemical additives are used in cooling water systems to control scale, slime, and corrosion. The chemical additives needed depend on the character of the make-up water. All additives have definite limitations and cannot eliminate the need for blowdown. Care should be taken in selecting nontoxic or readily degraded additives, if possible.

Solid Waste Aspects: The only solid waste associated with cooling towers may be removed scale.

Demonstration Status. Predominantly two types of waste streams

in the nonferrous metals manufacturing category are currently being recycled; casting contact cooling water and air pollution control scrubber liquor. Two variations of recycle are used: (1) a wastewater is recycled within a given process, and (2) a wastewater is combined with others, treated, and the combined wastewater is recycled to the processes from which it originated.

For example, scrubber liquor may be recycled within the scrubber, or treated by sedimentation and recycled back to the scrubber.

Total recycle may become more wide-spread in the future if methods for removal of dissolved solids, such as reverse osmosis and ion exchange, become more common and less expensive.

The Agency observed extensive recycle of contact cooling water and scrubber liquor throughout the category. Indeed, some plants reported 100 percent recycle of process wastewater from these operations. The Agency believes, however, that most plants may have to discharge a portion of the recirculating flow to prevent the excessive build-up of dissolved solids unless dragout of solids in products or slags is sufficient to prevent this build-up.

Existing practice supports the selection of a 90 percent recycle rate. Twenty-nine of 61 aluminum smelting and forming plants practice greater than 90 percent recycle of the direct chill casting contact cooling water. Two of the five aluminum smelters practicing continuous rod casting recycle 90 percent or more of their contact cooling water. Four of eight primary aluminum plants using wet air pollution control on anode bake ovens, five of 11 plants using wet scrubbers on potlines, and three of eight plants using wet scrubbers for potrooms recycle 90 percent or more of their scrubber water.

Five of 10 primary electrolytic copper plants currently recycle 90 percent or more of their casting contact cooling water. Two of three primary zinc plants with leaching scrubbers recycle 90 percent or more. Two of five primary tungsten plants with scrubbers on reduction furnaces practice 90 percent or greater recycle. Six of seven secondary silver plants with furnace scrubbers currently recycle 90 percent or more of the scrubber water.

Process Water Reuse

Reuse of process water is the practice of recirculating water used in one production process for subsequent use in a different production process.

Application and Performance. Reuse of wastewater in a different process can include using a relatively clean wastewater for another application, or using a relatively dirty water for an application where water quality is of no concern.

Advantages and Limitations. Advantages of reuse are similar to

the advantages of recycle. Water consumption is reduced and wastewater treatment facilities can be sized for smaller flows. Also, in areas where water shortages occur, reuse is an effective means of conserving water.

Operational Factors. The hardware necessary for reuse of process wastewaters varies, depending on the specific application. The basic elements include pumps and piping. Chemical addition is not usually warranted, unless treatment is required prior to reuse. Maintenance and energy use are limited to that required by the pumps. Solid waste generated is dependent upon the type of treatment used and will be discussed separately with each unit process.

Demonstration Status. Reuse applications in the nonferrous metals manufacturing category are varied. For example, a secondary uranium facility reuses wastewater from evaporation and calcination wet air pollution control in raw material leaching operations. Bauxite refineries commonly reuse water from red mud impoundments in digestion operations. A primary aluminum plant reuses wastewater from casting for air scrubbing. A lead smelter uses wastewater from air scrubbing for slag granulation, where all the water is evaporated. A primary copper refinery reuses precipitated spent electrolyte, known as "black acid," in leaching operations that are part of an ore beneficiation plant.

Process Water Use Reduction

Process water use reduction is the decrease in the amount of process water used as an influent to a production process per unit of production. Section V of each of the subcategory supplements discusses water use in detail for each nonferrous metals manufacturing operation. A range of water use values taken from the data collection portfolios is presented for each operation. The range of values indicates that some plants use process water more efficiently than others for the same operation.

Application and Performance. Noncontact cooling water can replace contact cooling water in some applications. The use of noncontact heat exchangers eliminates concentration of dissolved solids by evaporation and minimizes scaling problems. A copper refinery is currently using this method to achieve zero discharge. However, industry-wide conversion to noncontact cooling may not be possible because of a need for extensive retrofitting. Certain molten metals require contact cooling to produce desired surface characteristics. Some plants produce a metal shot by allowing molten metal to flow through a screen into a tank of water, immediately quenching the metal and producing a spherical shot product. Shot, generally cannot be produced without contact cooling water.

Air Cooling of Cast Metal Products

Application and Performance. Air cooling, for some operations,

is an alternative to contact cooling water but limited potential except in low tonnage situations. For example, air cooling is not generally used in the production of high tonnage casting for several reasons. The casting line can be inordinately long (or large), a result of an increased number of molds to compensate for the slower cooling of the metal.

Operational Factors. Maintenance costs are generally higher because of the longer conveyer, the added heat load on equipment and lubricants, and the need for added air blowers. Air cooling without these process appurtenances might greatly reduce finished metal production from rates now possible with water cooling.

Conversion to dry air pollution control equipment, discussed further on in this section, is another way to eliminate water use.

Dry Slag Processing and Granulation

Slag from pyrometallurgical processes is a solid waste that must be disposed of or reprocessed. Slag can be prepared for disposal by slag granulation or slag dumping.

Application and Performance. Slag granulation uses a high-velocity water jet to produce a finely divided and evenly sized rock, which can be used as concrete agglomerate or for road surfacing. Slag dumping is the dumping and subsequent solidification of slag, composed almost entirely of insolubles, which can be crushed and sized for such applications as road surfacing. Slag can be reprocessed if the metal content is high enough to be economically recovered. Wet or dry milling, and recovery of metal by melting can be used to process slag with recoverable amounts of metal. Of course, in all slag reuse processes, ultimate disposal of the reprocessed slag must be considered.

Operational Factors. Although slag dumping eliminates the wastewater associated with slag granulation, an additional factor is that large volumes of dust are generated during subsequent crushing operations and dust control systems may be necessary.

Demonstration Status. Four of the seven primary lead smelters currently granulate slag prior to disposal. One of the four plants granulates the slag, mixes the granulated slag in with ore concentrate feed to sintering to control lead content of the feed.

Dry Air Pollution Control Devices

Application and Performance. The use of dry air pollution control devices would allow the elimination of waste streams with high pollution potentials. The choice of air pollution control equipment is complicated, and sometimes a wet system is the necessary choice. The important difference between wet and dry devices is that wet devices control gaseous pollutants as well as

particulates.

Wet devices may be chosen over dry devices when any of the following factors are found: (1) the particle size is predominantly under 20 microns, (2) flammable particles or gases are to be treated at minimal combustion risk, (3) both vapors and particles are to be removed from the carrier medium, (4) the gases are corrosive and may damage dry air pollution control devices, and (5) the gases are hot and may damage dry air pollution control devices.

Equipment for dry control of air emissions includes cyclones, dry electrostatic precipitators, fabric filters, and afterburners. These devices remove particulate matter, the first three by entrapment and the afterburners by combustion.

Afterburner use is limited to air emissions consisting mostly of combustible particles. Characteristics of the particulate-laden gas which affect the design and use of a device are gas density, temperature, viscosity, flammability, corrosiveness, toxicity, humidity, and dew point. Particulate characteristics which affect the design and use of a device are particle size, shape, density, resistivity, concentration, and other physiochemical properties.

In the primary and secondary aluminum subcategories, melting prior to casting requires wet air pollution control only when chlorine gas is present in the offgases. Dry air pollution control methods with inert gas or salt furnace fluxing have been demonstrated in the category. It is possible to perform all the metal treatment tasks of removing hydrogen, non-metallic inclusions, and undesirable trace elements and meet the most stringent quality requirements without furnace fluxing, using only in-line metal treatment units. To achieve this, the molten aluminum is treated in the transfer system between the furnace and casting units by flowing the metal through a region of very fine, dense, mixed-gas bubbles generated by a spinning rotor or nozzle. No process wastewater is generated in this operation. A schematic diagram depicting the spinning nozzle refining principle is shown in Figure VII-32 (page xxx). Another similar alternate degassing method is to replace the chlorine-rich degassing agent with a mixture of inert gases and a much lower proportion of chlorine. The technique provides adequate degassing while permitting dry scrubbing.

To the extent that nonferrous metals manufacturing processes are designed to limit the volume or severity of air emissions, the volume of scrubber water used for air pollution control also can be reduced. For example, new or replacement furnaces can be designed to minimize emission volumes.

Advantages and Limitations. Proper application of a dry control device can result in particulate removal efficiencies greater than 99 percent by weight for fabric filters, electrostatic precipitators, and afterburners, and up to 95 percent for

cyclones.

Common wet air pollution control devices are wet electrostatic precipitators, venturi scrubbers, and packed tower scrubbers. Collection efficiency for gases will depend on the solubility of the contaminant in the scrubbing liquid. Depending on the contaminant removed, collection efficiencies usually approach 99 percent for particles and gases.

Demonstration Status. Plants in the primary and secondary aluminum, primary zinc, primary lead, secondary copper, secondary silver, primary precious metals and mercury, and secondary precious metals subcategories all report the use of dry air pollution control devices on furnaces and smelting operations.

Good Housekeeping

Good housekeeping and proper equipment maintenance are necessary factors in reducing wastewater loads to treatment systems. Control of accidental spills of oils, process chemicals, and wastewater from washdown and filter cleaning or removal can aid in abating or maintaining the segregation of wastewater streams. Curbed areas should be used to contain or control these wastes.

Leaks in pump casings, process piping, etc., should be minimized to maintain efficient water use. One particular type of leakage which may cause a water pollution problem is the contamination of noncontact cooling water by hydraulic oils, especially if this type of water is discharged without treatment.

Good housekeeping is also important in chemical, solvent, and oil storage areas to preclude a catastrophic failure situation. Storage areas should be isolated from high fire-hazard areas and arranged so that if a fire or explosion occurs, treatment facilities will not be overwhelmed nor excessive groundwater pollution caused by large quantities of chemical-laden fire-protection water.

A conscientiously applied program of water use reduction can be a very effective method of curtailing unnecessary wastewater flows. Judicious use of washdown water and avoidance of unattended running hoses can significantly reduce water use.

TABLE VII-1

pH CONTROL EFFECT ON METALS REMOVAL

	Day 1		Day 2		Day 3	
	<u>In</u>	<u>Out</u>	<u>In</u>	<u>Out</u>	<u>In</u>	<u>Out</u>
pH Range	2.4-3.4	8.5-8.7	1.0-3.0	5.0-6.0	2.0-5.0	6.5-8.1
(mg/l)						
TSS	39	8	16	19	16	7
Copper	312	0.22	120	5.12	107	0.66
Zinc	250	0.31	32.5	25.0	43.8	0.66

TABLE VII-2

EFFECTIVENESS OF SODIUM HYDROXIDE FOR METALS REMOVAL

	Day 1		Day 2		Day 3	
	<u>In</u>	<u>Out</u>	<u>In</u>	<u>Out</u>	<u>In</u>	<u>Out</u>
pH Range	2.1-2.9	9.0-9.3	2.0-2.4	8.7-9.1	2.0-2.4	8.6-9.1
(mg/l)						
Cr	0.097	0.0	0.057	0.005	0.068	0.005
Cu	0.063	0.018	0.078	0.014	0.053	0.019
Fe	9.24	0.76	15.5	0.92	9.41	0.95
Pb	1.0	0.11	1.36	0.13	1.45	0.11
Mn	0.11	0.06	0.12	0.044	0.11	0.044
Ni	0.077	0.011	0.036	0.009	0.069	0.011
Zn	0.054	0.0	0.12	0.0	0.19	0.037
TSS		13		11		11

TABLE VII-3

EFFECTIVENESS OF LIME AND SODIUM HYDROXIDE FOR METALS REMOVAL

	Day 1		Day 2		Day 3	
	<u>In</u>	<u>Out</u>	<u>In</u>	<u>Out</u>	<u>In</u>	<u>Out</u>
pH range (mg/l)	9.2-9.6	8.3-9.8	9.2	7.6-8.1	9.6	7.8-8.2
Al	37.3	0.35	38.1	0.35	29.9	0.35
Co	3.92	0.0	4.65	0.0	4.37	0.0
Cu	0.65	0.003	0.63	0.003	0.72	0.003
Fe	137	0.49	110	0.57	208	0.58
Mn	175	0.12	205	0.012	245	0.12
Ni	6.86	0.0	5.84	0.0	5.63	0.0
Se	28.6	0.0	30.2	0.0	27.4	0.0
Ti	143	0.0	125	0.0	115	0.0
Zn	18.5	0.027	16.2	0.044	17.0	0.01
TSS	4390	9	3595	13	2805	13

TABLE VII-4

THEORETICAL SOLUBILITIES OF HYDROXIDES AND SULFIDES
OF SELECTED METALS IN PURE WATER

Metal	Solubility of metal ion, mg/l		
	<u>As Hydroxide</u>	<u>As Carbonate</u>	<u>As Sulfide</u>
Cadmium (Cd ⁺⁺)	2.3 x 10 ⁻⁵	10 x 10 ⁻⁴	6.7 x 10 ⁻¹⁰
Chromium (Cr ⁺⁺⁺)	8.4 x 10 ⁻⁴		No precipitate
Cobalt (Co ⁺⁺)	2.2 x 10 ⁻¹		1.0 x 10 ⁻⁸
Copper (Cu ⁺⁺)	2.2 x 10 ⁻²		5.8 x 10 ⁻¹⁸
Iron (Fe ⁺⁺)	8.9 x 10 ⁻¹		3.4 x 10 ⁻⁵
Lead (Pb ⁺⁺)	2.1	7.0 x 10 ⁻³	3.8 x 10 ⁻⁹
Manganese (Mn ⁺⁺)	1.2		2.1 x 10 ⁻³
Mercury (Hg ⁺⁺)	3.9 x 10 ⁻⁴	3.9 x 10 ⁻²	9.0 x 10 ⁻²⁰
Nickel (Ni ⁺⁺)	6.9 x 10 ⁻³	1.9 x 10 ⁻¹	6.9 x 10 ⁻⁸
Silver (Ag ⁺)	13.3	2.1 x 10 ⁻¹	7.4 x 10 ^{-12s}
Tin (Sn ⁺⁺)	1.1 x 10 ⁻⁴		3.8 x 10 ⁻⁸
Zinc (Zn ⁺⁺)	1.1	7.0 x 10 ⁻⁴	2.3 x 10 ⁻⁷

TABLE VII-5

SAMPLING DATA FROM SULFIDE
PRECIPITATION-SEDIMENTATION SYSTEMS

Treatment	Lime, FeS, Polyelectrolyte, Settle, Filter		Lime, FeS, Polyelectrolyte, Settle, Filter		NaOH, Ferric Chloride, Na ₂ S Clarify (1 stage)	
	In	Out	In	Out	In	Out
+						
pH	5.0-6.8	8-9	7.7	7.38		
(mg/l)						
Cr ⁺⁶	25.6	<0.014	0.022	<0.020	11.45	<.005
Cr	32.3	<0.04	2.4	<0.1	18.35	<.005
Cu					0.029	0.003
Fe	0.52	0.10	108	0.6		
Ni			0.68	<0.1		
Zn	39.5	<0.07	33.9	0.01	0.060	0.009

These data were obtained from three sources:

Summary Report, Control and Treatment Technology for the Metal Finishing Industry: Sulfide Precipitation, USEPA, EPA No. 625/8/80-003, 1979.

Industrial Finishing, Vol. 35, No. 11, November, 1979.

Electroplating sampling data from plant 27045.

TABLE VII-6

SULFIDE PRECIPITATION-SEDIMENTATION PERFORMANCE

<u>Parameter</u>	<u>Treated Effluent</u> (mg/l)
Cd	0.01
Cr (T)	0.05
Cu	0.05
Pb	0.01
Hg	0.03
Ni	0.05
Ag	0.05
Zn	0.01

Table VII-6 is based on two reports:

Summary Report, Control and Treatment Technology for the Metal Finishing Industry: Sulfide Precipitation, USEPA, EPA No. 625/8/80-003, 1979.

Addendum to Development Document for Effluent Limitations Guidelines and New Source Performance Standards, Major Inorganic Products Segment of Inorganics Point Source Category, USEPA., EPA Contract No. EPA 68-01-3281 (Task 7), June, 1978.

TABLE VII-7

FERRITE CO-PRECIPIATION PERFORMANCE

Metal	Influent (mg/l)	Effluent (mg/l)
Mercury	7.4	0.001
Cadmium	240	0.008
Copper	10	0.010
Zinc	18	0.016
Chromium	10	<0.010
Manganese	12	0.007
Nickel	1,000	0.200
Iron	600	0.06
Bismuth	240	0.100
Lead	475	0.010

NOTE: These data are from:

Sources and Treatment of Wastewater in the Nonferrous Metals Industry, USEPA, EPA No. 600/2-80-074, 1980.

TABLE VII-8

CONCENTRATION OF TOTAL CYANIDE
(mg/l)

<u>Plant</u>	<u>Method</u>	<u>In</u>	<u>Out</u>
1057	FeSO ₄	2.57	0.024
		2.42	0.015
		3.28	0.032
33056	FeSO ₄	0.14	0.09
		0.16	0.09
12052	ZnSO ₄	0.46	0.14
		0.12	<u>0.06</u>
Mean			0.07

TABLE VII-9

MULTIMEDIA FILTER PERFORMANCE

<u>Plant ID #</u>	<u>TSS Effluent Concentration, mg/l</u>
06097	0.0, 0.0, 0.5
13924	1.8, 2.2, 5.6, 4.0, 4.0, 3.0, 2.2, 2.8 3.0, 2.0, 5.6, 3.6, 2.4, 3.4
18538	1.0
30172	1.4, 7.0, 1.0
36048	2.1, 2.6, 1.5
mean	2.61

TABLE VII-10

PERFORMANCE OF SELECTED SETTLING SYSTEMS

<u>PLANT ID</u>	<u>SETTLING DEVICE</u>	<u>SUSPENDED SOLIDS CONCENTRATION (mg/l)</u>					
		<u>Day 1</u>		<u>Day 2</u>		<u>Day 3</u>	
		<u>In</u>	<u>Out</u>	<u>In</u>	<u>Out</u>	<u>In</u>	<u>Out</u>
01057	Lagoon	54	6	56	6	50	5
09025	Clarifier & Settling Ponds	1100	9	1900	12	1620	5
11058	Clarifier	451	17				
12075	Settling Pond	284	6	242	10	502	14
19019	Settling Tank	170	1	50	1		
33617	Clarifier & Lagoon			1662	16	1298	4
40063	Clarifier	4390	9	3595	12	2805	13
44062	Clarifier	182	13	118	14	174	23
46050	Settling Tank	295	10	42	10	153	8

TABLE VII-11

SKIMMING PERFORMANCE

<u>Plant</u>	<u>Skimmer Type</u>	<u>Oil & Grease (mg/l)</u>	
		<u>In</u>	<u>Out</u>
06058	API	224,669	17.9
06058	Belt	19.4	8.3

TABLE VII-12

SELECTED PARTITION COEFFICIENTS

<u>Priority Pollutant</u>	<u>Log Octanol-Water Partition Coefficient</u>
1 Acenaphthene	4.33
11 1,1,1-Trichloroethane	2.17
13 1,1-Dichloroethane	1.79
15 1,1,2,2-Tetrachloroethane	2.56
18 Bis(2-chloroethyl)ether	1.58
23 Chloroform	1.97
29 1,1-Dichloroethylene	1.48
39 Fluoranthene	5.33
44 Methylene chloride	1.25
64 Pentachlorophenol	5.01
66 Bis(2-ethylhexyl) phthalate	8.73
67 Butyl benzyl phthalate	5.80
68 Di-n-butyl phthalate	5.20
72 Benzo(a)anthracene	5.61
73 Benzo(a)pyrene	6.04
74 3,4-benzofluoranthene	6.57
75 Benzo(k)fluoranthene	6.84
76 Chrysene	5.61
77 Acenaphthylene	4.07
78 Anthracene	4.45
79 Benzo(ghi)perylene	7.23
80 Fluorene	4.18
81 Phenanthrene	4.46
82 Dibenzo(a,h)anthracene	5.97
83 Indeno(1,2,3,cd)pyrene	7.66
84 Pyrene	5.32
85 Tetrachloroethylene	2.88
86 Toluene	2.69

TABLE VII-13

TRACE ORGANIC REMOVAL BY SKIMMING
API PLUS BELT SKIMMERS
(From Plant 06058)

<u>Pollutant</u>	<u>Influent</u> (mg/l)	<u>Effluent</u> (mg/l)
Oil & Grease	225,000	14.6
Chloroform	0.023	0.007
Methylene Chloride	0.013	0.012
Naphthalene	2.31	0.004
N-nitrosodiphenylamine	59.0	0.182
Bis-2-ethylhexyl phthalate	11.0	0.027
Diethyl phthalate		
Butylbenzyl phthalate	0.005	0.002
Di-n-octyl phthalate	0.019	0.002
Anthracene - phenanthrene	16.4	0.014
Toluene	0.02	0.012

TABLE VII-14

COMBINED METALS DATA EFFLUENT VALUES (mg/l)

	<u>Mean</u>	<u>One Day</u> <u>Max.</u>	<u>10 Day Avg.</u> <u>Max.</u>	<u>30 Day Avg.</u> <u>Max.</u>
Cd	0.079	0.34	0.15	0.13
Cr	0.084	0.44	0.18	0.12
Cu	0.58	1.90	1.00	0.73
Pb	0.12	0.42	0.20	0.16
Ni	0.74	1.92	1.27	1.00
Zn	0.33	1.46	0.61	0.45
Fe	0.41	1.20	0.61	0.50
Mn	0.16	0.68	0.29	0.21
TSS	12.0	41.0	19.5	15.5

TABLE VII-15
L&S PERFORMANCE
ADDITIONAL POLLUTANTS
(mg/l)

<u>Pollutant</u>	<u>Average Performance</u>	<u>Pollutant</u>	<u>Average Performance</u>
Sb	0.7	Hf	7.28
As	0.51	In	0.084
Be	0.30	Mo	1.83
Hg	0.06	Pd	0.01
Se	0.30	P	4.08
Ag	0.10	Pt	0.01
Th	0.50	Ra-226	6.17
Al	2.24	Re	1.83
Ba	0.42	Rb	0.124
B	0.36	Ta	<0.12
Cz	0.124	Sn	0.14
Co	0.05	Ti	0.19
Nb	0.12	W	1.29
F	14.5	U	4.0
Ga	0.084	V	<0.10
Ge	0.084	Xr	7.28
Au	0.01		

NOTE: Ra-226 is in picocuries per liter

TABLE VII-16
COMBINED METALS DATA SET - UNTREATED WASTEWATER

<u>Pollutant</u>	<u>Min. Conc. (mg/l)</u>	<u>Max. Conc. (mg/l)</u>
Cd	<0.1	3.83
Cr	<0.1	116
Cu	<0.1	108
Pb	<0.1	29.2
Ni	<0.1	27.5
Zn	<0.1	337
Fe	<0.1	263
Mn	<0.1	5.98
TSS	4.6	4,390

TABLE VII-17

POLLUTANT CONTENT OF UNTREATED WASTEWATER
For Selection of Average Treatment Effectiveness for Additional Pollutants
(mg/l)

Specific Pollu- tant	Additional Pollutant ---->												
	Sb	As	Be	Ag	B	F	Ba,Mo&U	Ra-226	Sn	Ti	W	Zr	Nb&Ta
Sb	8.5	0.58	-	-	-	-	-	-	-	-	-	-	-
As	0.024	4.2	-	-	0.008	-	-	0.068	-	-	-	-	-
Be	-	-	10.24	-	0.02	-	-	-	-	-	-	-	-
Cd	0.83	<0.1	-	<0.1	0.043	<0.1	<0.25	-	1.88	<0.25	<0.03	<0.25	9.2
Cr	-	0.18	8.60	0.23	14.0	22.8	0.4	0.035	79.2	0.4	0.07	<0.3	13.
Cu	0.41	33.2	1.24	110.5	2.4	2.2	4.7	0.02	107.0	4.7	0.2	0.5	120.
Pb	76.0	6.5	0.35	11.4	2.70	5.35	9.2	0.065	0.16	9.2	0.2	22.	160.
Hg	-	-	-	-	-	-	-	-	-	-	-	-	-
Ni	-	-	-	100	34.0	0.69	1.4	0.06	47.7	1.4	0.9	<0.25	170.
Se	-	0.58	-	-	-	-	-	-	-	-	-	-	-
Ag	-	-	-	4.7	0.001	-	-	-	-	-	-	-	-
Zn	0.53	3.62	0.12	1512.	0.3	<0.1	0.6	0.17	197.	0.6	1.0	<0.25	0.5
Ba	-	-	-	-	-	-	2.6	-	-	-	-	-	-
B	-	-	-	-	17.0	-	1.6	-	-	-	-	-	-
Co	-	-	-	-	-	-	2.2	-	-	-	-	-	-
Ni	-	-	-	-	-	-	-	-	-	-	-	-	98.
F	-	-	-	-	1050.	760.	12.	-	9.25	12.	-	-	-
Fe	-	-	646.	-	62.0	-	-	-	38.3	-	-	-	-
Mo	-	-	-	-	0.5	-	9.2	0.07	-	-	-	-	-
Ra-226	-	-	-	-	-	-	-	1098.	-	-	-	-	-
Ta	-	-	-	-	-	-	-	-	-	-	-	-	90.
Sn	-	-	-	-	1.1	-	-	-	4.39	-	-	-	-
Ti	-	-	-	-	-	-	-	-	-	24	12	-	170.
W	-	-	-	-	-	-	-	-	-	-	2.4	-	37.
U	-	-	-	-	-	-	2.30	10.53	-	230	-	-	-
V	-	-	-	-	7.0	-	6.0	-	-	-	-	-	-
Zr	-	-	-	-	-	-	-	-	-	-	-	170.	6.7
O&G	-	16.9	-	16.	-	2.8	220.	-	33.	220.	<1.	860.	72.
TSS	134.	352.	796.	587.8	690.	5.6	420.	1639.	3500.	420.	<1.	42.	450.
Data Source	NFM 234	NFM 280& 214	NFM 3921	NFM	NFF #Y	E&EC 2258& 30167	NFF #V	OMD	MF 20086	NFF #D,V, X&Y	NFF #X	NFF #W&Z	NFF #X&Z

NOTES:

Values of Ra-226 in picocuries per liter.

(-) indicates pollutant not analyzed.

Data source consists of industry category and plant ID.

NFM - Nonferrous metals manufacturing

NFF - Nonferrous metals forming

E&EC - Electrical and electronic componets

MF - Metal Finishing

OMD - Ore Mining and Derassing

TABLE VII-18

PRECIPITATION-SETTLING-FILTRATION (LS&F) PERFORMANCE
Plant A

<u>Parameters</u>	<u>No Pts.</u>	<u>Range mg/l</u>	<u>Mean + std. dev.</u>	<u>Mean + 2 std. dev.</u>
<u>For 1979-Treated Wastewater</u>				
Cr	47	0.015 - 0.13	0.045 +0.029	0.10
Cu	12	0.01 - 0.03	0.019 ±0.006	0.03
Ni	47	0.08 - 0.64	0.22 ±0.13	0.48
Zn	47	0.08 - 0.53	0.17 ±0.09	0.35
Fe				
<u>For 1978-Treated Wastewater</u>				
Cr	47	0.01 - 0.07	0.06 + 0.10	0.26
Cu	28	0.005 - 0.055	0.016 ± 0.010	0.04
Ni	47	0.10 - 0.92	0.20 ± 0.14	0.48
Zn	47	0.08 - 2.35	0.23 ± 0.34	0.91
Fe	21	0.26 - 1.1	0.49 ± 0.18	0.85
<u>Raw Waste</u>				
Cr	5	32.0 - 72.0		
Cu	5	0.08 - 0.45		
Ni	5	1.65 - 20.0		
Zn	5	33.2 - 32.0		
Fe	5	10.0 - 95.0		

TABLE VII-19

PRECIPITATION-SETTLING-FILTRATION (LS&F) PERFORMANCE
Plant B

<u>Parameters</u>	<u>No Pts.</u>	<u>Range mg/l</u>	<u>Mean +</u> <u>std. dev.</u>	<u>Mean + 2</u> <u>std. dev.</u>
<u>For 1979-Treated Wastewater</u>				
Cr	175	0.0 - 0.40	0.068 +0.075	0.22
Cu	176	0.0 - 0.22	0.024 +0.021	0.07
Ni	175	0.01 - 1.49	0.219 +0.234	0.69
Zn	175	0.01 - 0.66	0.054 +0.064	0.18
Fe	174	0.01 - 2.40	0.303 +0.398	1.10
TSS	2	1.00 - 1.00		
<u>For 1978-Treated Wastewater</u>				
Cr	144	0.0 - 0.70	0.059 +0.088	0.24
Cu	143	0.0 - 0.23	0.017 +0.020	0.06
Ni	143	0.0 - 1.03	0.147 +0.142	0.43
Zn	131	0.0 - 0.24	0.037 +0.034	0.11
Fe	144	0.0 - 1.76	0.200 +0.223	0.47
<u>Total 1974-1979-Treated Wastewater</u>				
Cr	1288	0.0 - 0.56	0.038 +0.055	0.15
Cu	1290	0.0 - 0.23	0.011 +0.016	0.04
Ni	1287	0.0 - 1.88	0.184 +0.211	0.60
Zn	1273	0.0 - 0.66	0.035 +0.045	0.13
Fe	1287	0.0 - 3.15	0.402 +0.509	1.42
<u>Raw Waste</u>				
Cr	3	2.80 - 9.15	5.90	
Cu	3	0.09 - 0.27	0.17	
Ni	3	1.61 - 4.89	3.33	
Zn	2	2.35 - 3.39		
Fe	3	3.13 - 35.9	22.4	
TSS	2	177 - 466.		

TABLE VII-20

PRECIPITATION-SETTLING-FILTRATION (LS&F) PERFORMANCE
Plant C

<u>Parameters</u>	<u>No Pts.</u>	<u>Range (mg/l)</u>	<u>Mean +</u> <u>std. dev.</u>	<u>Mean + 2</u> <u>std. dev.</u>
<u>For Treated Wastewater</u>				
Cd	103	0.010 - 0.500	0.049 +0.049	0.147
Zn	103	0.039 - 0.899	0.290 +0.131	0.552
TSS	103	0.100 - 5.00	1.244 +1.043	3.33
pH	103	7.1 - 7.9	9.2*	
<u>For Untreated Wastewater</u>				
Cd	103	0.039 - 2.319	0.542 +0.381	1.304
Zn	103	0.949 - 29.8	11.009 +6.933	24.956
Fe	3	0.107 - 0.46	0.255	
TSS	103	0.80 - 19.6	5.616 +2.896	11.408
pH	103	6.8 - 8.2	7.6*	

* pH value is median of 103 values.

TABLE VII-21

SUMMARY OF TREATMENT EFFECTIVENESS (mg/l)

Pollutant Parameter	L & S Technology System				L S & F Technology System				Sulfide & Filter Technology System			
	Mean	One-day Maximum	10-day Average	30-day Average	Mean	One-day Maximum	10-day Average	30-day Average	Mean	One-day Maximum	10-day Average	30-day Average
114 Sb	0.70	2.87	1.28	1.14	0.47	1.93	0.86	0.76				
115 As	0.51	2.09	0.93	0.83	0.34	1.39	0.62	0.55				
117 Be	0.30	1.23	0.55	0.49	0.20	0.82	0.37	0.32				
118 Cd	0.079	0.34	0.15	0.13	0.049	0.20	0.08	0.08	0.01	0.04	0.02	0.02
119 Cr	0.084	0.44	0.18	0.12	0.07	0.37	0.15	0.10	0.08	0.21	0.09	0.08
120 Cu	0.58	1.90	1.00	0.73	0.39	1.28	0.61	0.49	0.05	0.21	0.09	0.08
121 CN	0.07	0.29	0.12	0.11	0.047	0.20	0.08	0.08				
122 Pb	0.12	0.42	0.20	0.16	0.08	0.28	0.13	0.11	0.01	0.04	0.02	0.02
123 Hg	0.06	0.25	0.10	0.10	0.036	0.15	0.06	0.06	0.03	0.13	0.06	0.05
124 Ni	0.74	1.92	1.27	1.00	0.22	0.55	0.37	0.29	0.05	0.21	0.09	0.08
125 Se	0.30	1.23	0.55	0.49	0.20	0.82	0.37	0.33				
126 Ag	0.10	0.41	0.17	0.16	0.07	0.29	0.12	0.10	0.05	0.21	0.09	0.08
127 Tl	0.50	2.05	0.91	0.81	0.34	1.40	0.61	0.55				
128 Zn	0.33	1.46	0.61	0.45	0.23	1.02	0.42	0.31	0.01	0.04	0.02	0.02
Al	2.24	6.43	3.20	2.52	1.49	6.11	2.71	2.41				
Co	0.05	0.21	0.09	0.08	0.034	0.14	0.07	.06				
F	14.50	35.00	19.90		14.50	35.00	19.90					
Fe	0.41	1.20	0.61	0.50	0.28	1.20	0.61	.50				
Mn	0.16	0.68	0.29	0.21	0.14	0.30	0.23	.19				
P	4.08	16.70	6.83	6.60	2.72	11.20	4.60	4.40				
O&G		20.00	12.00	10.00		10.00	10.00	10.00				
TSS	12.00	41.00	19.50	15.50	2.60	15.00	12.00	10.00				
Ammonia	32.20	133.30	58.60	52.10	32.20	133.30	58.60	52.10				
Barium	0.42	5.55	2.54	NC	0.28	1.15	0.51	NC				
Boron	0.36	1.84	0.84	NC	0.36	1.84	0.84	NC				
Cesium	0.124	0.51	0.23	NC	0.124	0.51	0.23	NC				
Gallium	0.084	0.44	0.18	0.12	0.07	0.37	0.15	0.10				
Germanium	0.084	0.44	0.18	0.12	0.07	0.37	0.15	0.10				
Gold	**	*.10	**	**	**	*.10	**	**				
Hafnium	7.28	28.80	13.90	NC	4.81	19.70	9.01	NC				
Indium	0.084	0.44	0.18	0.12	0.07	.37	0.15	0.10				
Molybdenum	1.83	6.61	3.42	NC	1.23	5.03	2.23	NC				
Palladium	**	*.10	**	**	**	*.10	**	**				
Platinum	**	*.10	**	**	**	*.10	**	**				
Radium***	6.17	30.00	11.23	10.00	4.13	20.00	7.52	6.67				
Rhenium	1.83	6.61	3.42	NC	1.23	5.03	2.23	NC				
Rubidium	0.124	0.51	0.23	NC	0.124	0.51	0.23	NC				
Tantalum	**	*.45	**	**	**	*.45	**	**				
Tin	0.14	0.38	0.22	**	0.14	0.38	0.22	**				
Titanium	0.19	0.94	0.41	NC	0.13	0.53	0.23	NC				
Tungsten	1.29	6.96	2.78	NC	0.85	3.48	1.55	NC				
Uranium	4.00	6.50	4.73	NC	2.67	4.29	3.12	NC				
Vanadium	**	*.10	**	**	**	*.10	**	**				
Zirconium	7.28	28.80	13.90	NC	4.81	19.70	9.01	NC				

07/03/86

NC - Not Calculated
 * - Limits of detection
 ** - None established
 *** - Isotope 226, values in
 picocuries per liter

TABLE VII-22

TREATABILITY RATING OF PRIORITY POLLUTANTS
UTILIZING CARBON ADSORPTION

Priority Pollutant

1.	acenaphthene	H	48.	dichlorobromomethane	M
2.	acrolein	L	51.	chlorodibromomethane	H
3.	acrylonitrile	L	52.	hexachlorobutadiene	H
4.	benzene	M	53.	hexachlorocyclopentadiene	H
5.	benzidine	H	54.	isophorone	H
6.	carbon tetrachloride	H	55.	naphthalene	H
7.	chlorobenzene	H	56.	nitrobenzene	H
8.	1,2,4-trichlorobenzene	H	57.	2-nitrophenol	H
9.	hexachlorobenzene	H	58.	4-nitrophenol	H
10.	1,2-dichloroethane	M	59.	2,4-dinitrophenol	H
11.	1,1,1-trichloroethane	M	60.	4,6-dinitro-o-cresol	H
12.	hexachloroethane	H	61.	N-nitrosodimethylamine	M
13.	1,1-dichloroethane	M	62.	N-nitrosodiphenylamine	H
14.	1,1,2-trichloroethane	M	63.	N-nitrosodi-n-propylamine	M
15.	1,1,2,2-tetrachloroethane	H	64.	pentachlorophenol	H
16.	chloroethane	L	65.	phenol	M
18.	bis (2-chloroethyl) ether	M	66.	bis(2-ethylhexyl) phthalate	H
19.	2-chloroethyl vinyl ether	L	67.	butyl benzyl phthalate	H
20.	2-chloronaphthalene	H	68.	di-n-butyl phthalate	H
21.	2,4,6-trichlorophenol	H	69.	di-n-octyl phthalate	H
22.	parachlorometa cresol	H	70.	diethyl phthalate	H
23.	chloroform (trichloromethane)	L	71.	dimethyl phthalate	H
24.	2-chlorophenol	H	72.	benzo (a)anthracene	H
25.	1,2-dichlorobenzeneH		73.	benzo (a)pyrene	H
26.	1,3-dichlorobenzene	H	74.	3,4-benzofluoranthene	H
27.	1,4-dichlorobenzene	H	75.	benzo(k)fluoranthene	H
28.	3,3'-dichlorobenzidine	H	76.	chrysene	H
29.	1,1-dichloroethylene	L	77.	acenaphthylene	H
30.	1,2-trans-dichloroethylene	L	78.	anthracene	H
31.	2,4-dichlorophenol	H	79.	benzo(ghi)perylene	H
32.	1,2-dichloropropane	M	80.	fluorene	H
33.	1,2-dichloropropylene	M	81.	phenanthrene	H
34.	2,4-dimethylphenol	H	82.	dibenzo (a,h)anthracene	H
35.	2,4-dinitrotoluene	H	83.	indeno (1,2,3-cd)pyrene	H
36.	2,6-dinitrotoluene	H	84.	pyrene	-
37.	1,2-diphenylhydrazine	H	85.	tetrachloroethylene	M
38.	ethylbenzene	M	86.	toluene	M
39.	fluoranthene	H	87.	trichloroethylene	L
40.	4-chlorophenyl phenyl ether	H	88.	vinyl chloride	L
41.	4-bromophenyl phenyl ether	H	106.	PCB-1242 (Arochlor 1242)	H
42.	bis(2-chloroisopropyl) ether	M	107.	PCB-1254 (Arochlor 1254)	H
43.	bis(2-chloroethoxy) methane	M	108.	PCB-1221 (Arochlor 1221)	H
44.	methylene chloride	L	109.	PCB-1232 (Arochlor 1232)	H
45.	methyl chloride	L	110.	PCB-1248 (Arochlor 1248)	H
46.	methyl bromide	L	111.	PCB-1260 (Arochlor 1260)	H
47.	bromoform (tribromomethane)	H	112.	PCB-1016 (Arochlor 1016)	H

Category H (high removal)

Adsorbs at levels >100 mg/g carbon at $C_f = 10$ mg/lAdsorbs at levels ≥ 100 mg/g carbon at $C_f < 10$ mg/l

Category M (high removal)

Adsorbs at levels >100 mg/g carbon at $C_f = 10$ mg/lAdsorbs at levels ≤ 100 mg/g carbon at $C_f < 10$ mg/l

Category L (high removal)

Adsorbs at levels <100 mg/g carbon at $C_f = 10$ mg/lAdsorbs at levels <100 mg/g carbon at $C_f < 10$ mg/l C_f = final concentration of priority pollutant at equilibrium.

TABLE VII-23

CLASSES OF ORGANIC COMPOUNDS ADSORBED ON CARBON

<u>Organic Chemical Class</u>	<u>Example of Chemical Class</u>
Aromatic Hydrocarbons	Benzene, toluene, xylene
Polynuclear Hydrocarbons	Napthalene, anthracene, biphenols
Chlorinated Aromatics	Chlorobenzene, pollychlorinated biphenyls, aldrin, endrin
Phenolics	Phenol, cresol, resorcenol, polyphenyls
Chlorinated Phenolics	Trichlorophenol, pentachlorophenol
High Molecular Weight Alphatic and Branch Chain Hydrocarbons	Gasoline, kerosine
Chlorinated Alphatic Hydrocarbons	Carbon tetrachloride, chlorethylenes
High Molecular Weight Alphatic Acids and Aromatic Acids	Tar acids, benzoic acid
High Molecular Weight Alphatic Amines and Aromatic Amines	analine, toluene, diamine
High Molecular Weight Ketones, Esters, Ethers and Alcohols	Hydroquinone, polyethylene glycol
Surfactants	alkyl benzene sulfonates
Soluble Organic Dyes	Melkylene blue, Indigo carmine

High molecular weight includes compounds in the broad range from four to 20 carbon atoms.

TABLE VII-24

ACTIVATED CARBON PERFORMANCE (MERCURY)

<u>Plant</u>	<u>Mercury levels (mg/l)</u>	
A	28.0	0.9
B	0.36	0.015
C	0.008	0.0005

TABLE VII-25

ION EXCHANGE PERFORMANCE
(mg/l)

<u>Parameter</u>	<u>Plant A</u>		<u>Plant B</u>	
	<u>In</u>	<u>Out</u>	<u>In</u>	<u>Out</u>
Al	5.6	0.20	-	-
Cd	5.7	0.00	-	-
Cr ⁺³	3.1	0.01	-	-
Cr ⁺⁶	7.1	0.01	-	-
Cu	4.5	0.09	43.0	0.10
CN	9.8	0.04	3.40	0.09
Au	-	-	2.30	0.10
Fe	7.4	0.01	-	-
Pb	-	-	1.79	0.01
Mn	4.4	0.00	-	-
Ni	6.2	0.00	1.60	0.01
Ag	1.5	0.00	9.10	0.01
SO ₄	-	-	210.00	2.00
Sn	1.7	0.00	1.10	0.10
Zn	14.8	0.40	-	-

TABLE VII-26

MEMBRANE FILTRATION SYSTEM EFFLUENT

<u>Specific Metal</u>	<u>Manufacturers Guarantee</u>	<u>Plant 19066 In</u>	<u>Plant 19066 Out</u>	<u>Plant 31022 In</u>	<u>Plant 31022 Out</u>	<u>Predicted Performance</u>
Al	0.5					
Cr ⁺⁶	0.02	0.46	0.01	5.25	<0.005	
Cr (T)	0.03	4.13	0.018	98.4	0.057	0.05
Cu	0.1	18.8	0.043	8.00	0.222	0.02
Fe	0.1	288	0.3	21.1	0.263	0.30
Pb	0.05	0.652	0.01	0.288	0.01	0.05
CN	0.02	<0.005	<0.005	<0.005	<0.005	0.02
Ni	0.1	9.56	0.017	194	0.352	0.40
Zn	0.1	2.09	0.046	5.00	0.051	0.10
TSS		632	0.1	13.0	8.0	1.0

TABLE VII-27

PEAT ADSORPTION PERFORMANCE
(mg/l)

<u>Pollutant</u>	<u>In</u>	<u>Out</u>
Cr ⁺⁶	35000	0.04
Cu	250	0.24
CN	36.0	0.7
Pb	20.0	0.025
Hg	1.0	0.02
Ni	2.5	0.07
Ag	1.0	0.05
Sb	2.5	0.9
Zn	1.5	0.25

TABLE VII-28

ULTRAFILTRATION PERFORMANCE

<u>Parameter</u>	<u>Feed (mg/l)</u>	<u>Permeate (mg/l)</u>
Oil (Freon extractable)	1230	4
COD	8920	148
TSS	1380	13
Total Solids	2900	296

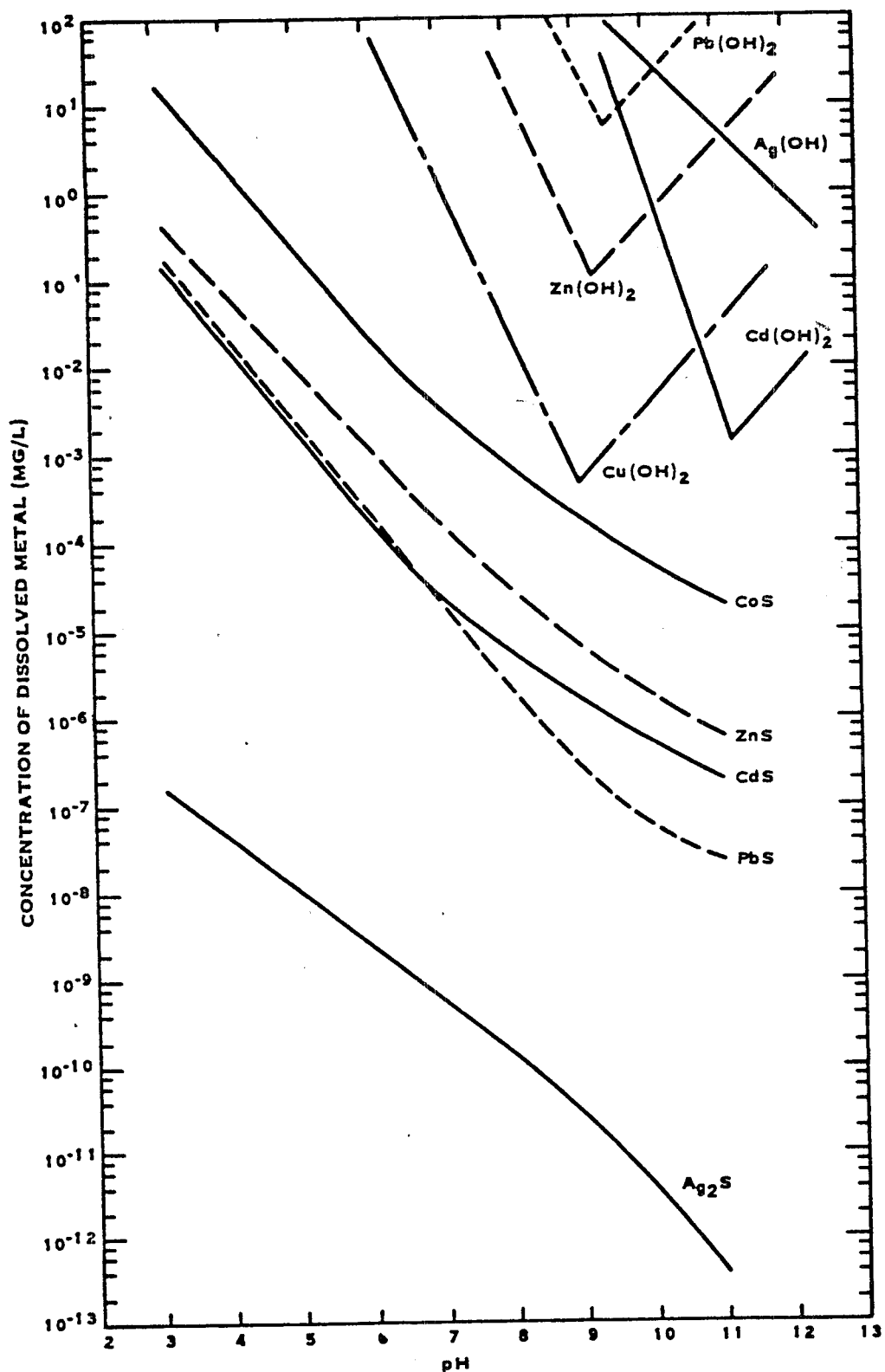

FIGURE VII - 1. COMPARATIVE SOLUBILITIES OF METAL HYDROXIDES AND SULFIDE AS A FUNCTION OF pH

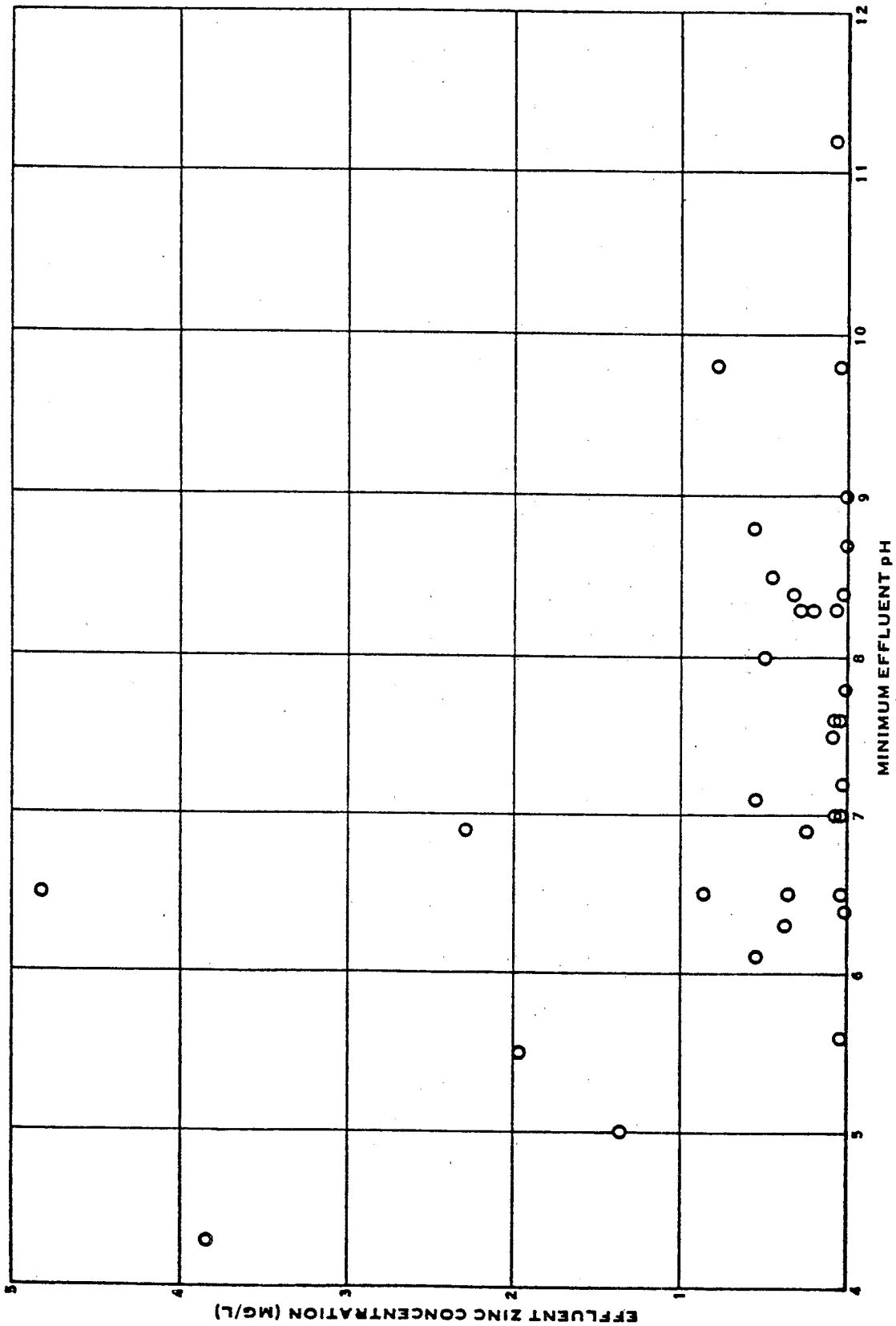

FIGURE VII 2 EFFLUENT ZINC CONCENTRATION VS. MINIMUM EFFLUENT pH

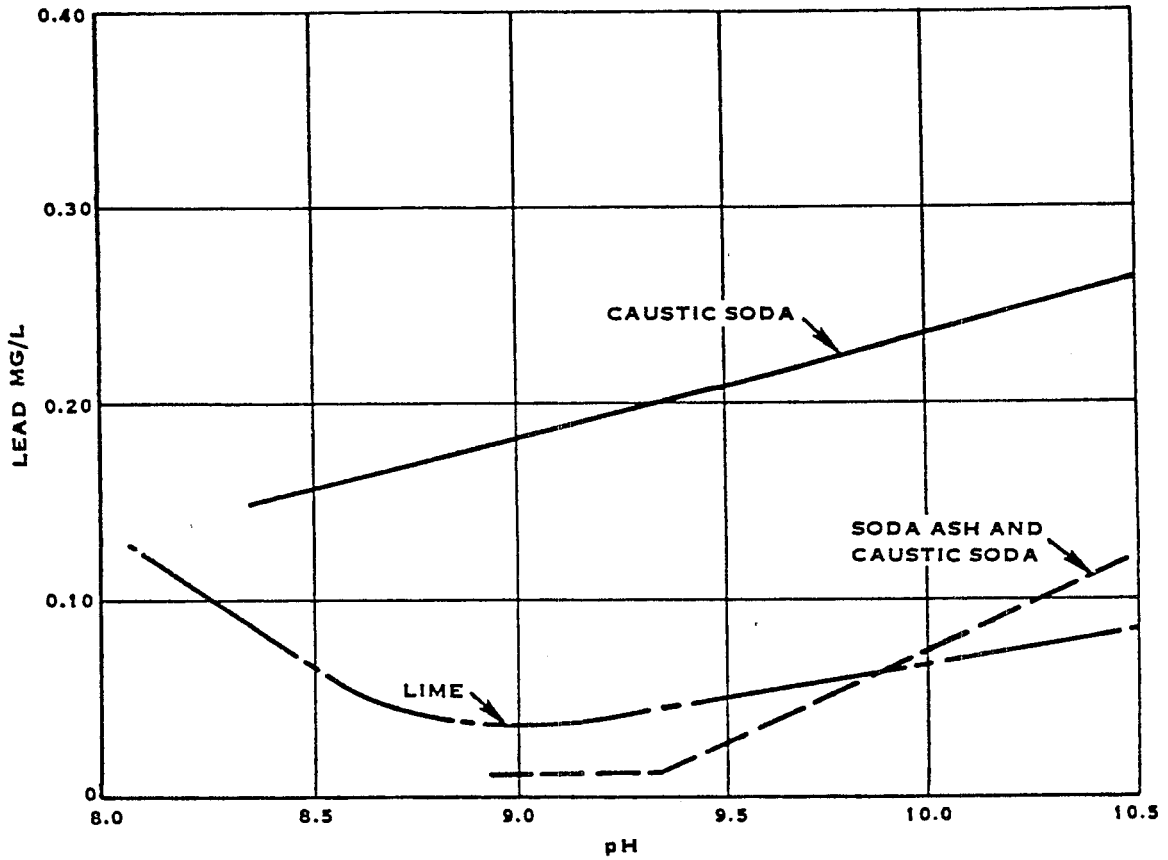
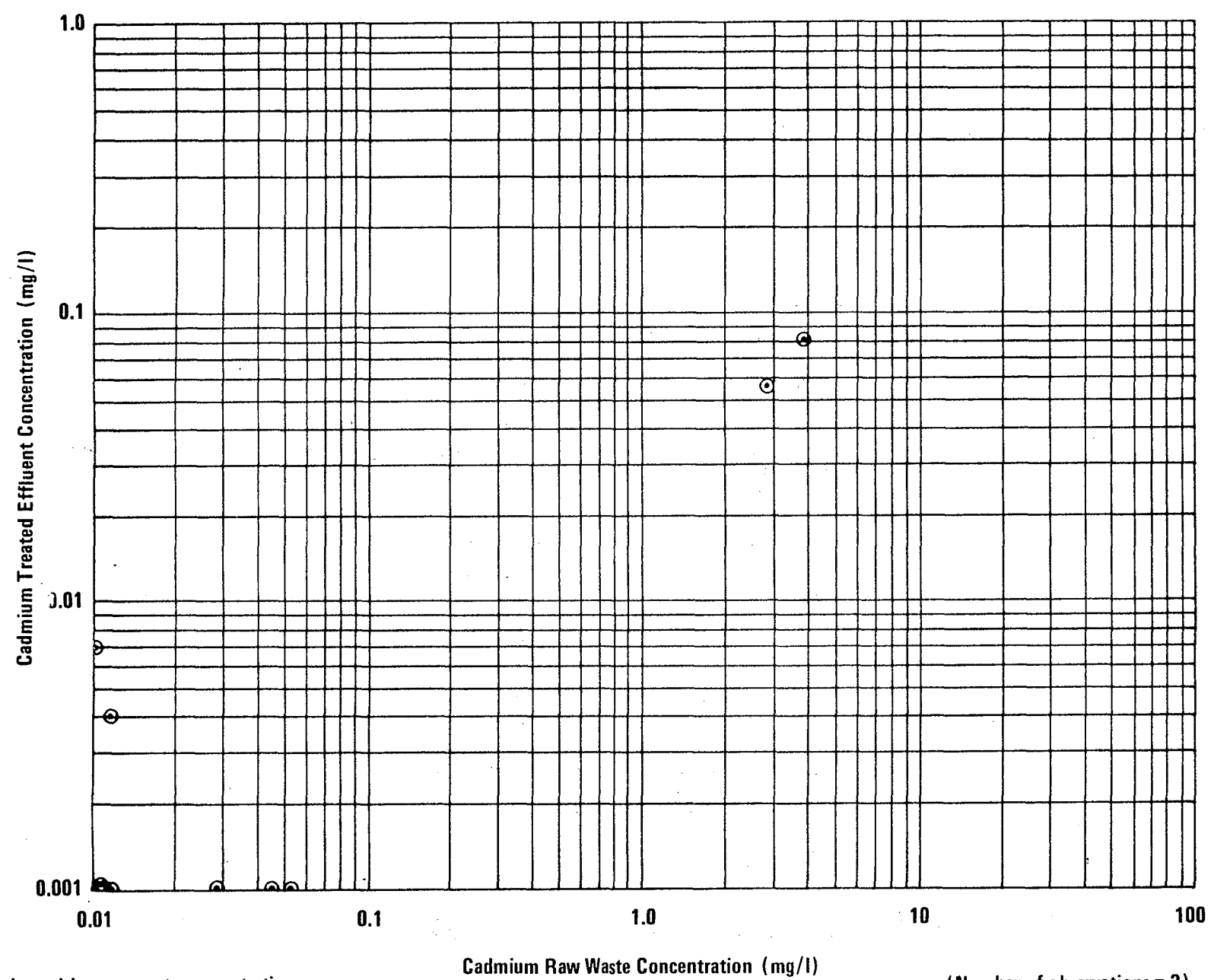

FIGURE VII - 3 LEAD SOLUBILITY IN THREE ALKALIES

257



Data points with a raw waste concentration less than 0.1 mg/l were not included in treatment effectiveness calculations.

(Number of observations = 2)

FIGURE VII-4
HYDROXIDE PRECIPITATION SEDIMENTATION EFFECTIVENESS
CADMIUM

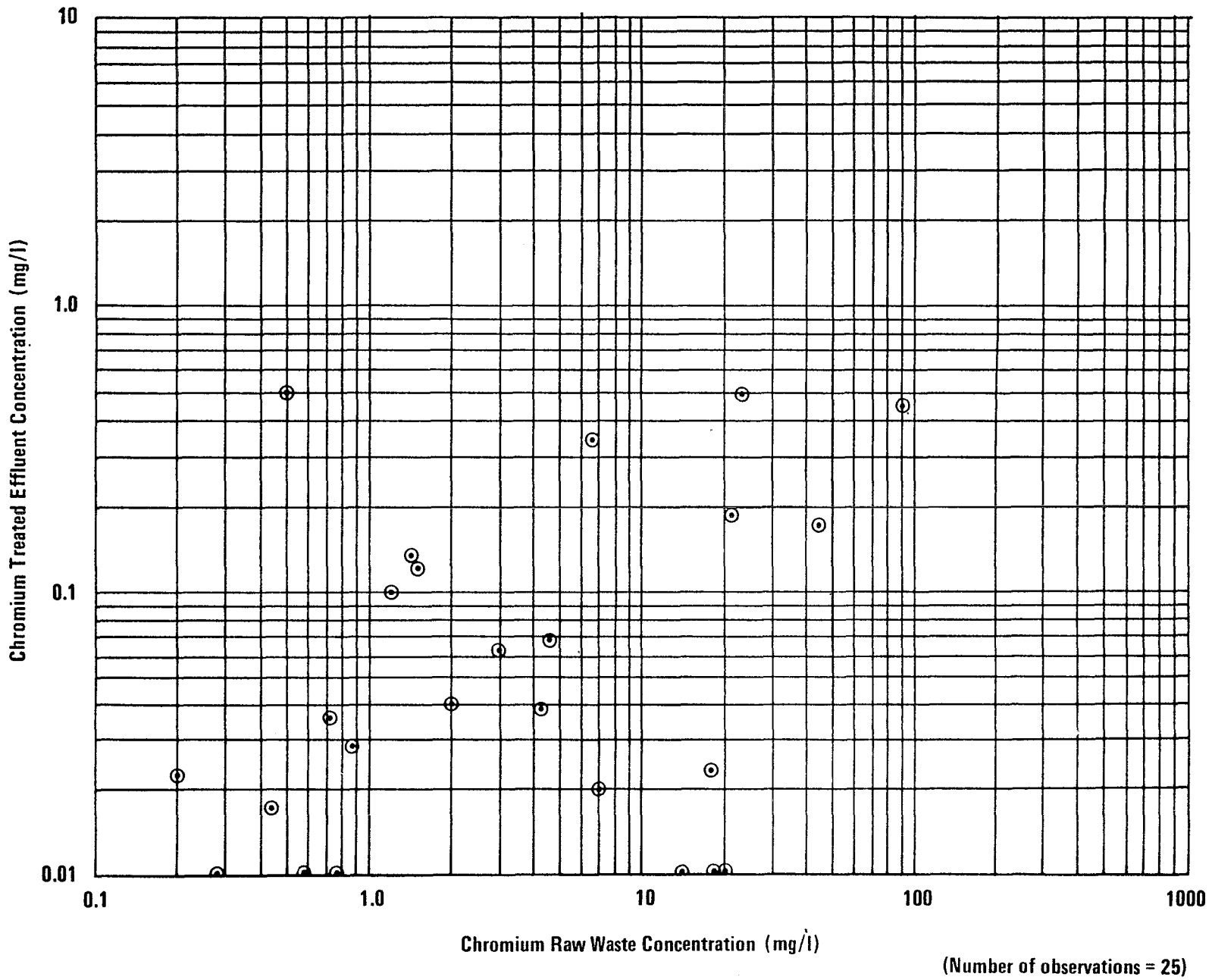

FIGURE VII-5
HYDROXIDE PRECIPITATION SEDIMENTATION EFFECTIVENESS
CHROMIUM

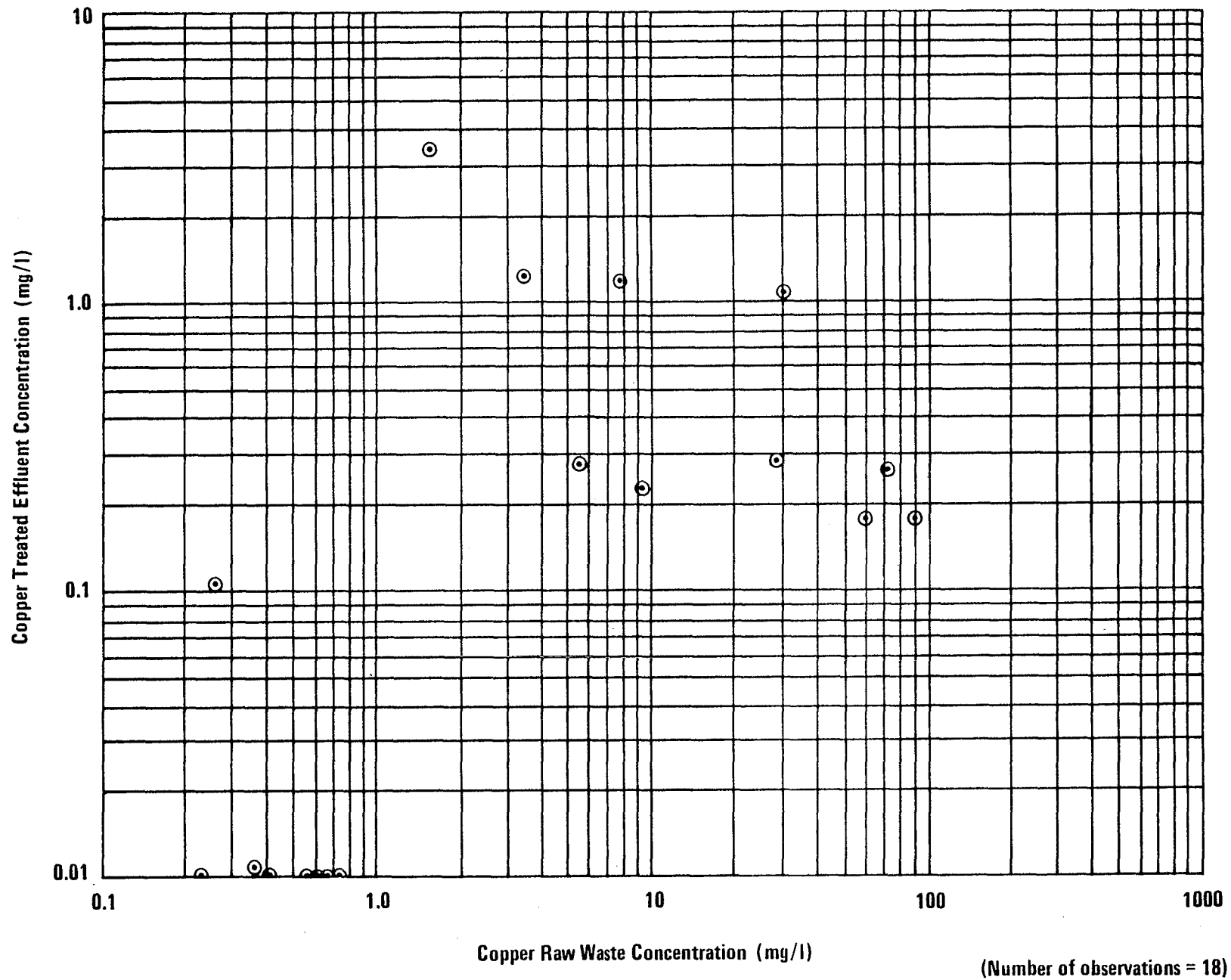

FIGURE VII-6
HYDROXIDE PRECIPITATION SEDIMENTATION EFFECTIVENESS
COPPER

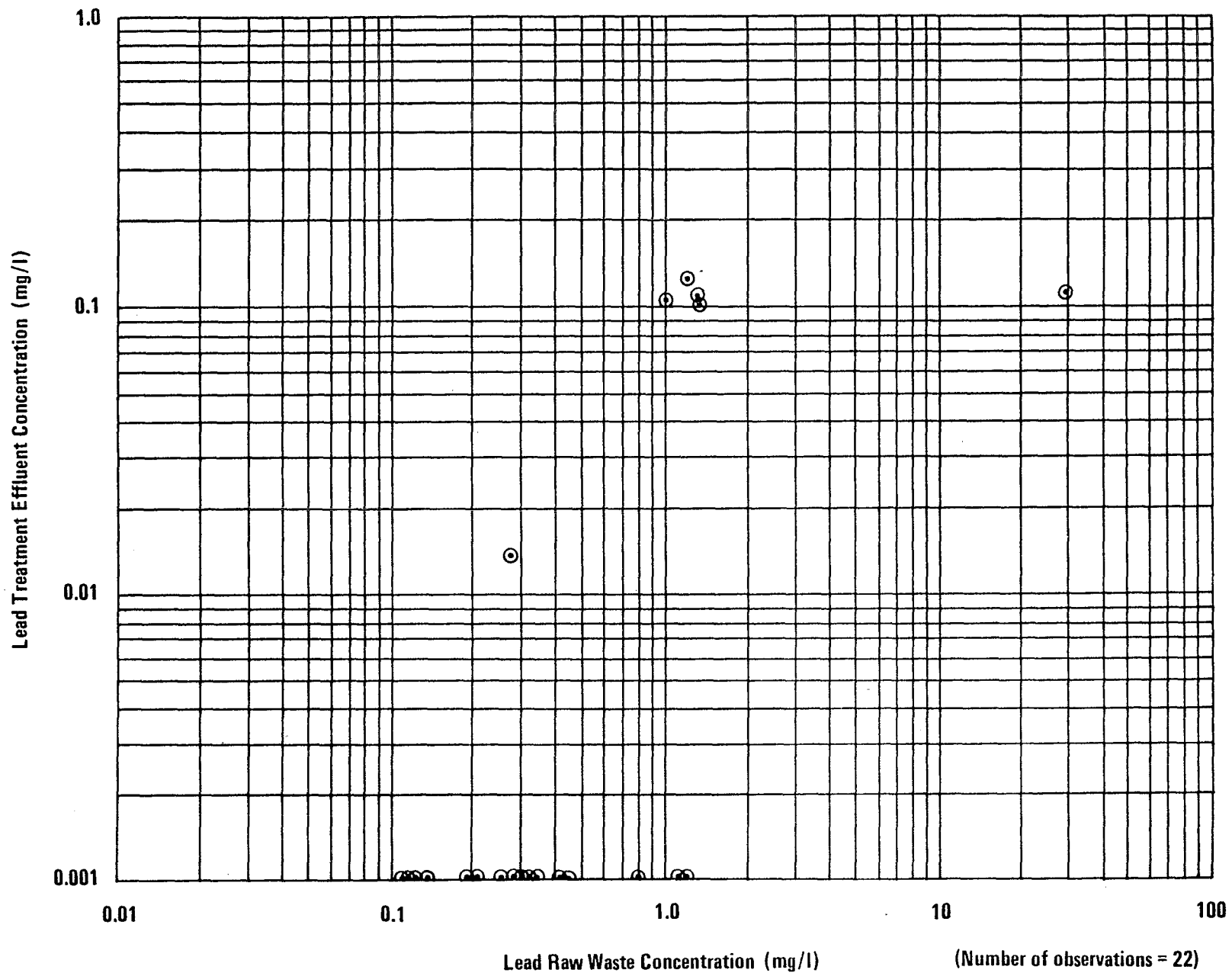

FIGURE VII-7
HYDROXIDE PRECIPITATION SEDIMENTATION EFFECTIVENESS
LEAD

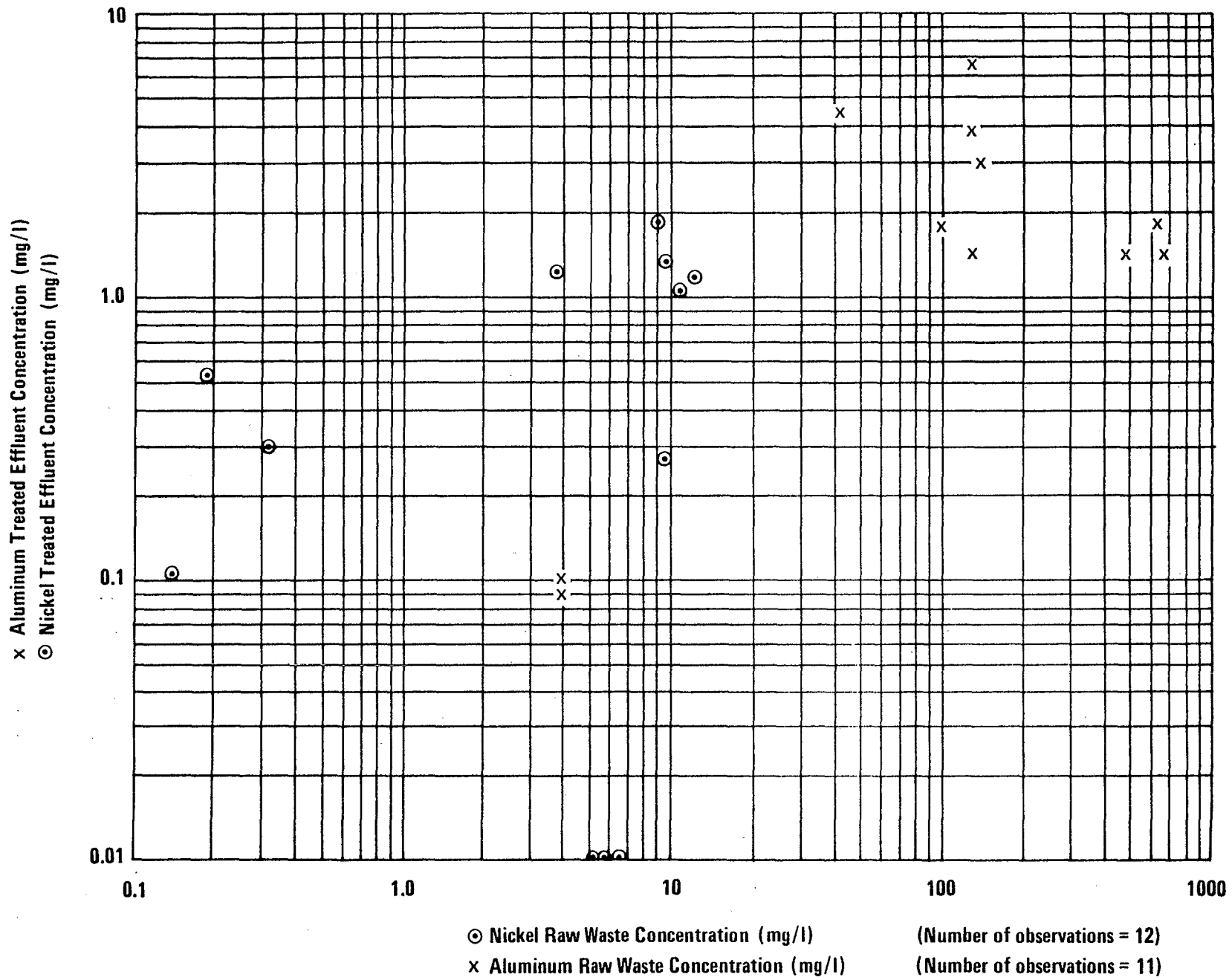
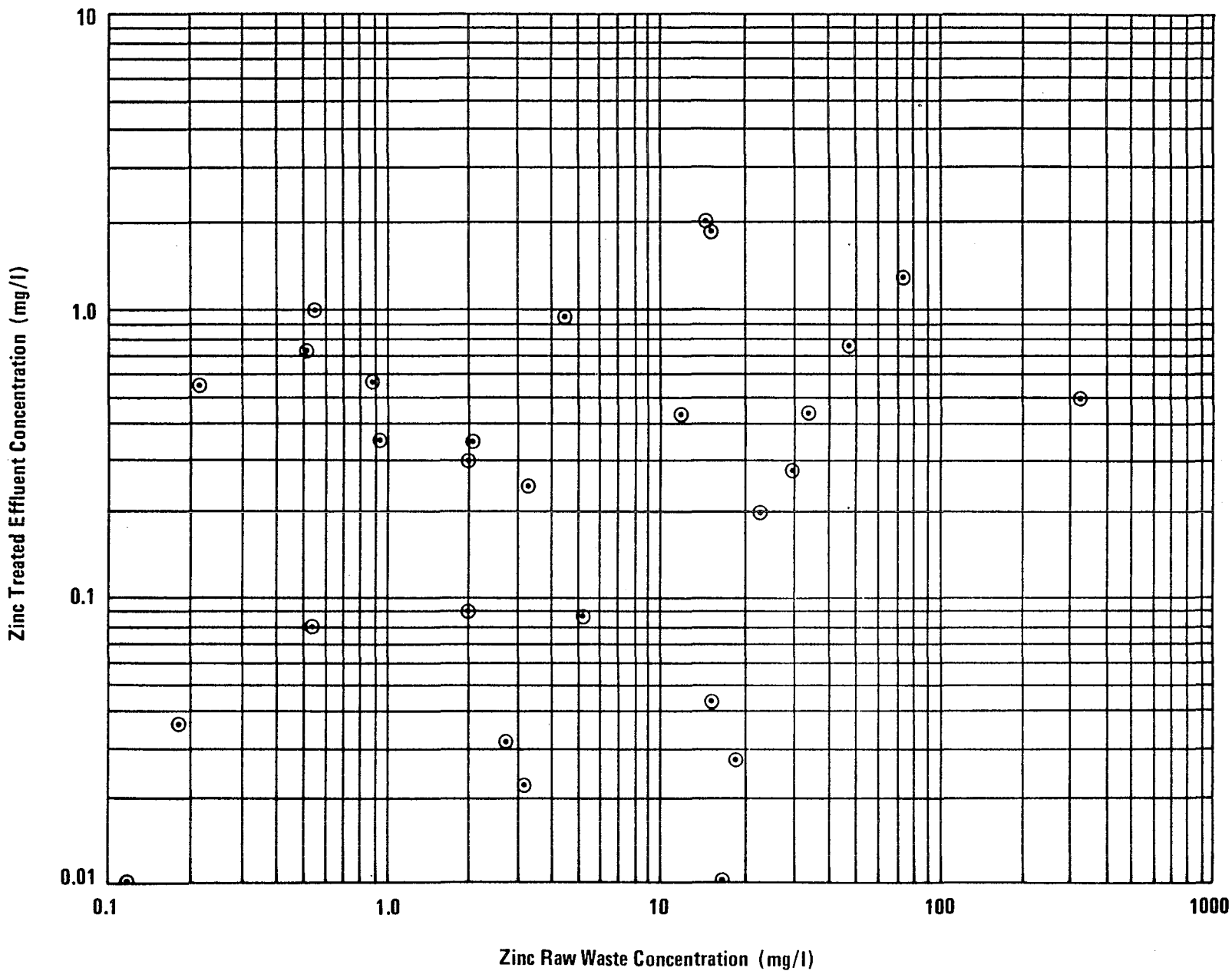
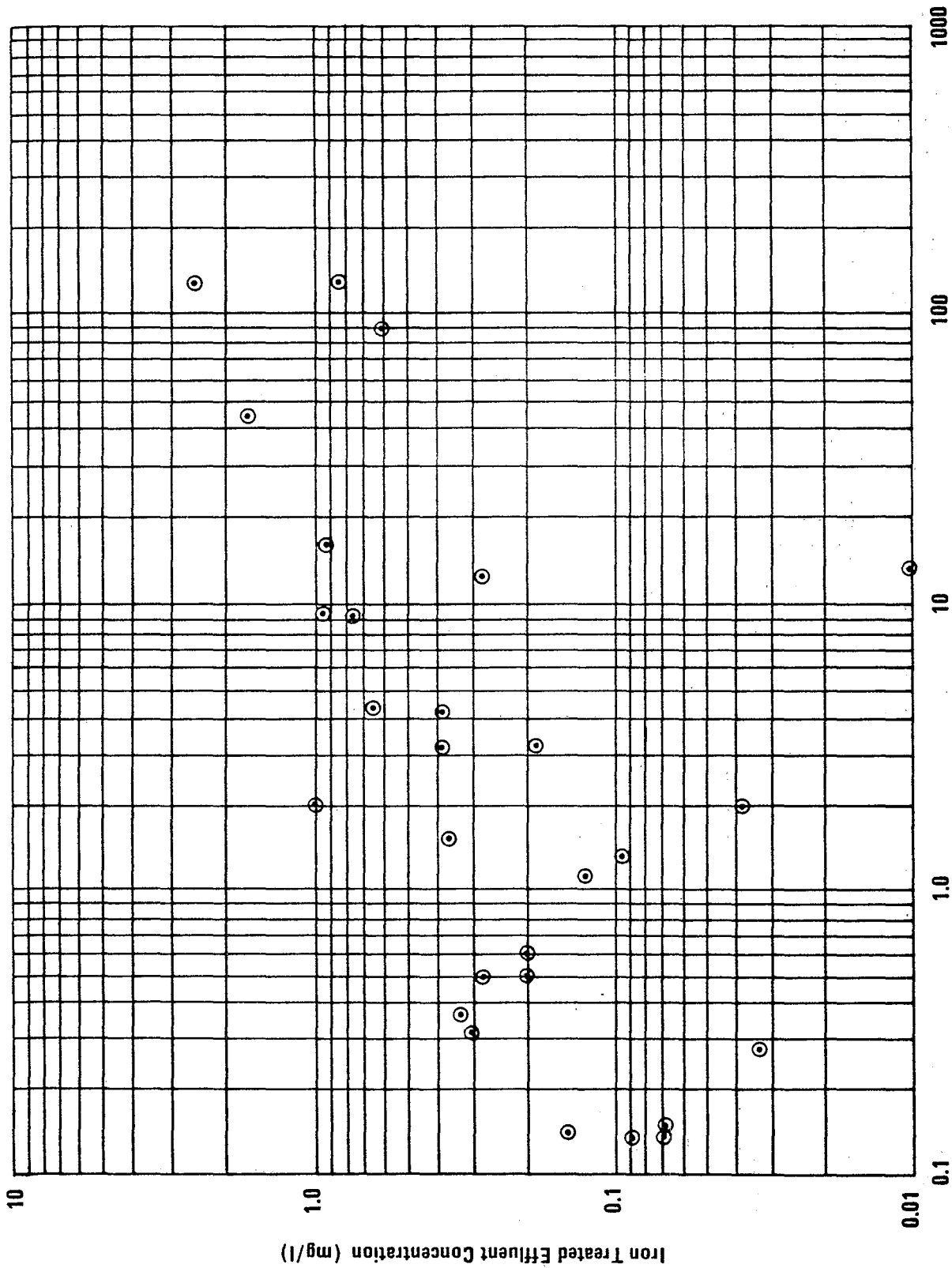

FIGURE VII-8
 HYDROXIDE PRECIPITATION SEDIMENTATION EFFECTIVENESS
 NICKEL AND ALUMINUM



(Number of observations = 28)

FIGURE VII-9
HYDROXIDE PRECIPITATION SEDIMENTATION EFFECTIVENESS
ZINC



Iron Raw Waste Concentration (mg/l) (Number of observations = 28)

FIGURE VII-10
HYDROXIDE PRECIPITATION SEDIMENTATION EFFECTIVENESS
IRON

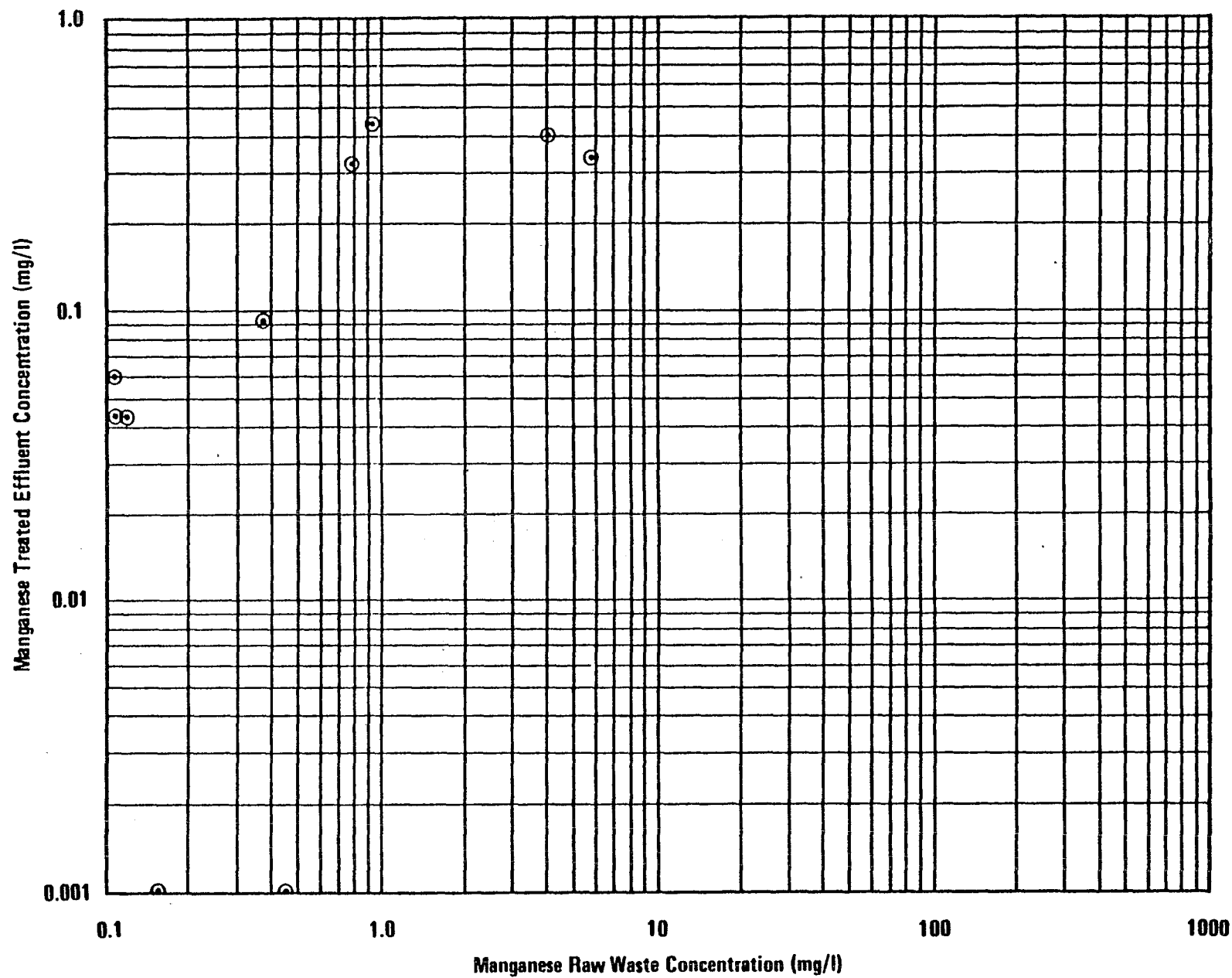

(Number of observations = 10)

FIGURE VII-11
HYDROXIDE PRECIPITATION SEDIMENTATION EFFECTIVENESS
MANGANESE

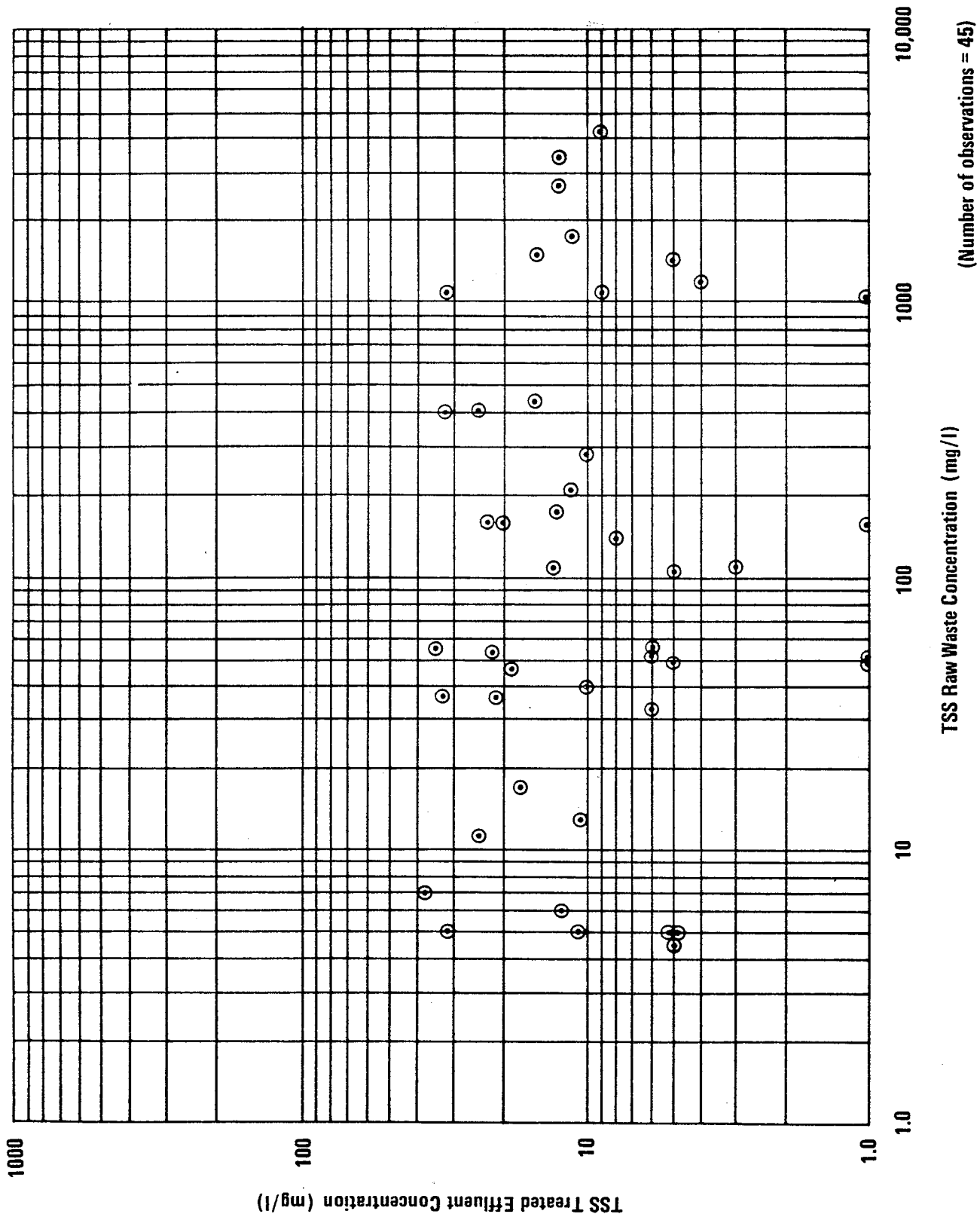

(Number of observations = 45)

FIGURE VII-12
HYDROXIDE PRECIPITATION SEDIMENTATION EFFECTIVENESS
TSS

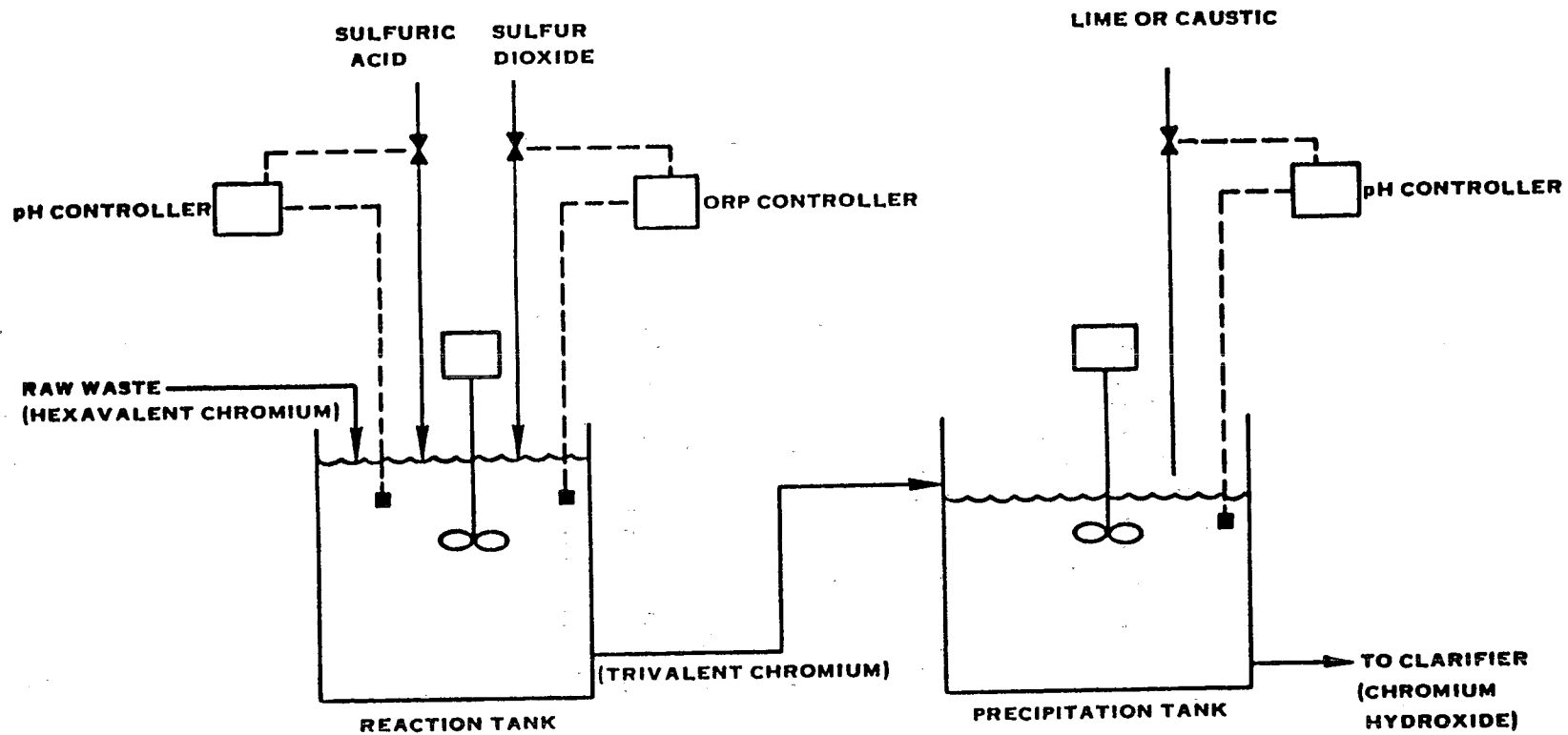

FIGURE VII-13. HEXAVALENT CHROMIUM REDUCTION WITH SULFUR DIOXIDE

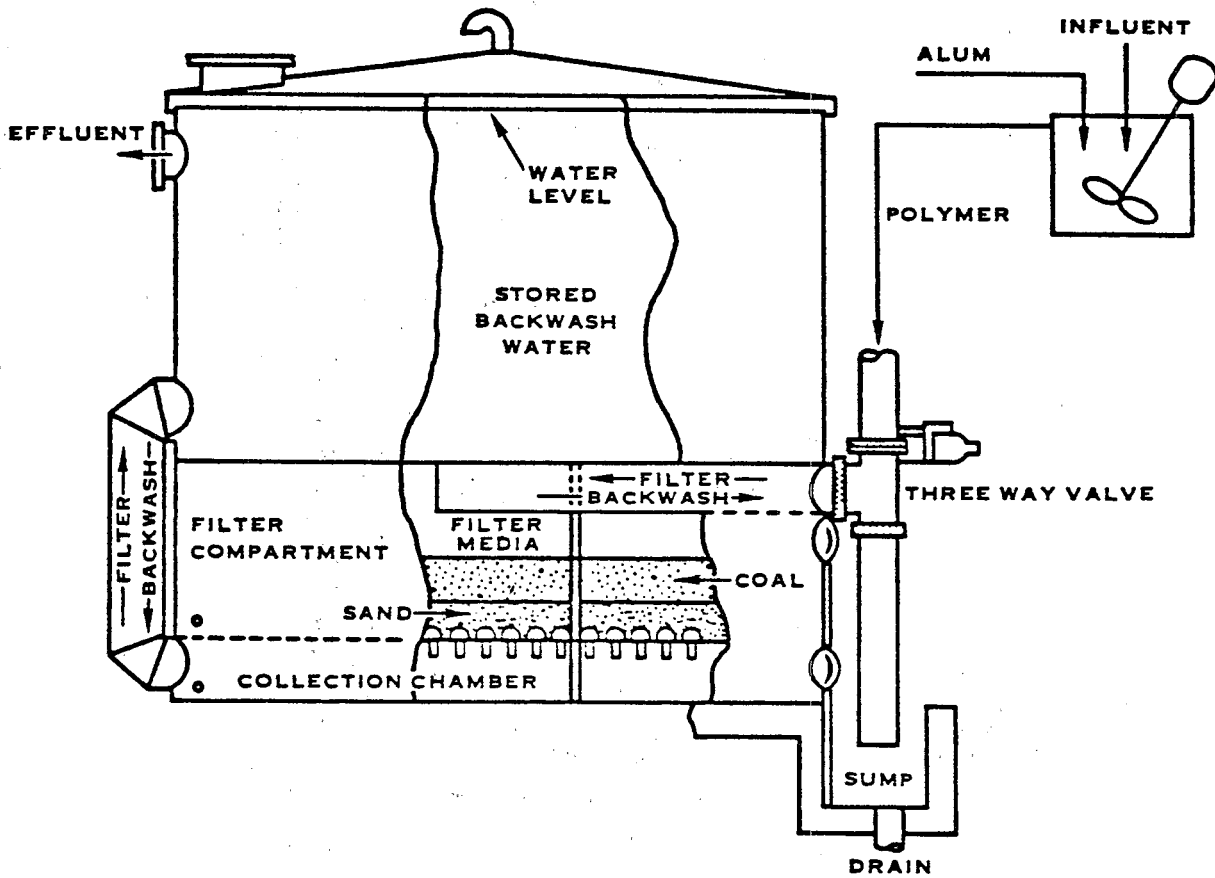

FIGURE VII-14. GRANULAR BED FILTRATION

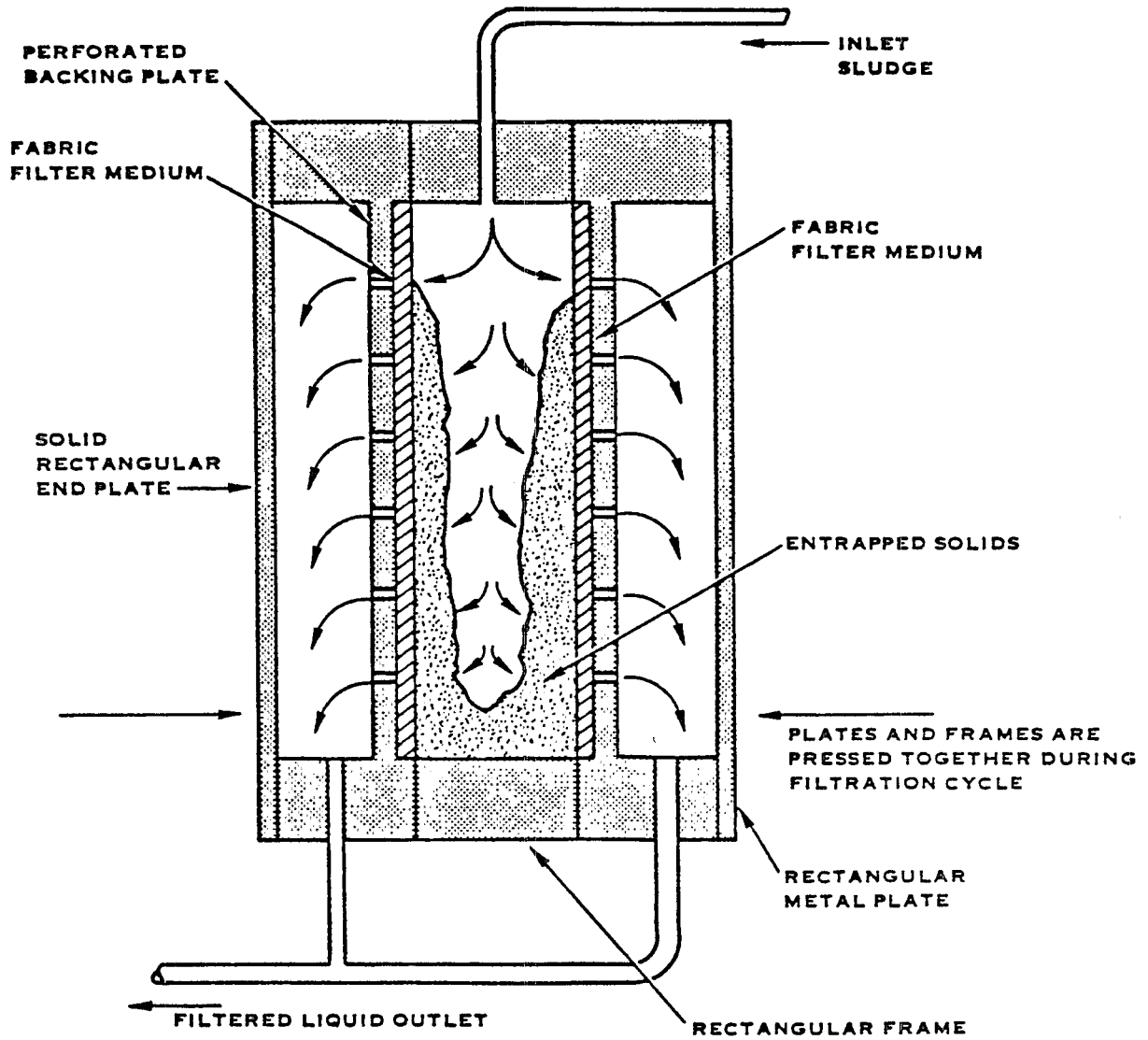
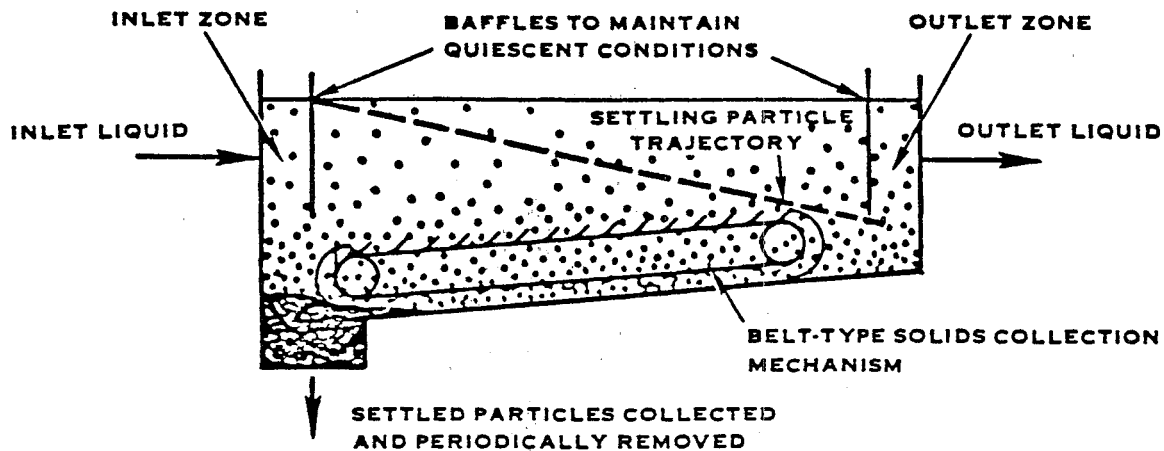

FIGURE VII-15. PRESSURE FILTRATION

SEDIMENTATION BASIN



CIRCULAR CLARIFIER

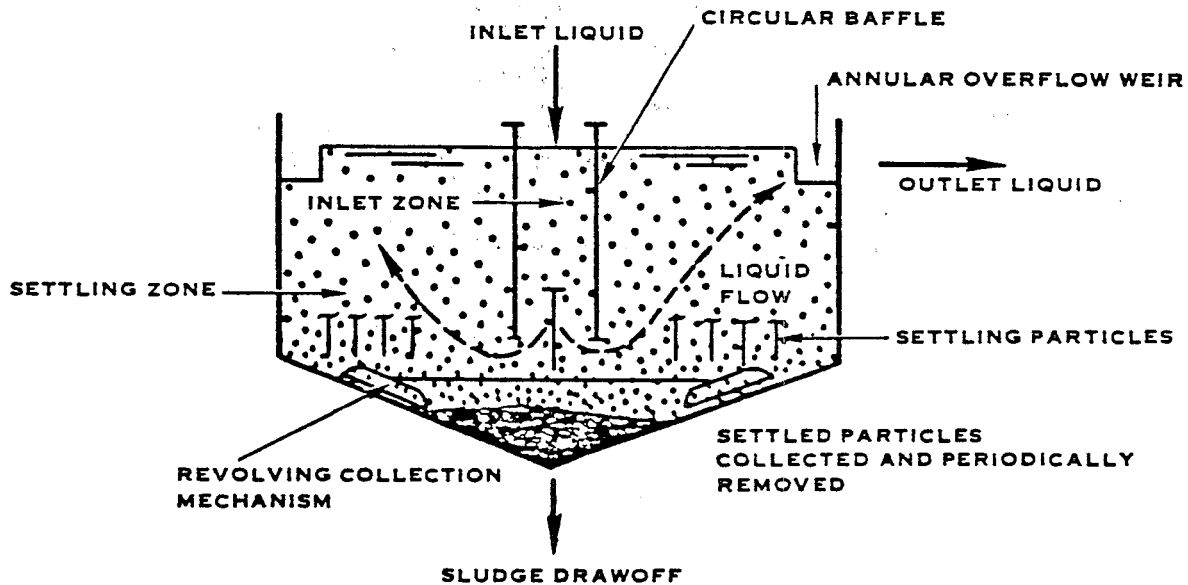

FIGURE VII-16. REPRESENTATIVE TYPES OF SEDIMENTATION

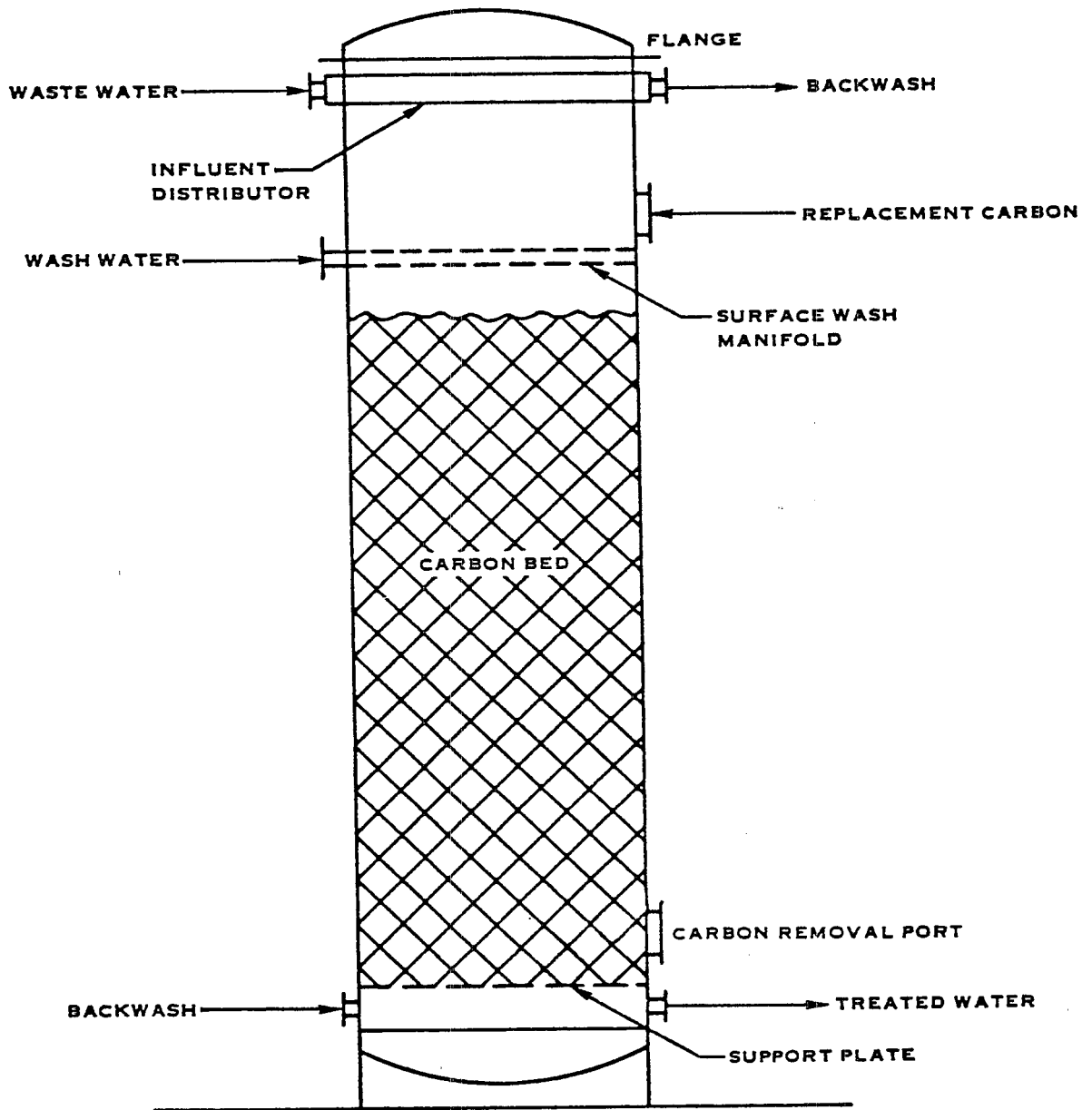

FIGURE VII - 17. ACTIVATED CARBON ADSORPTION COLUMN

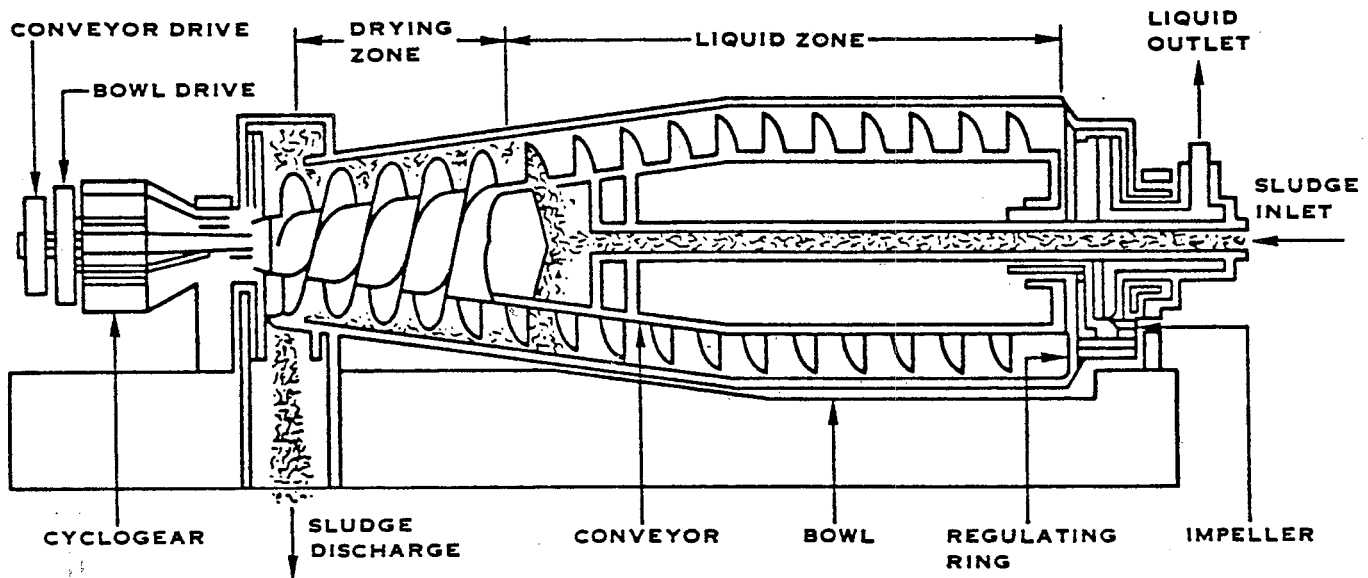

FIGURE VII - 18. CENTRIFUGATION

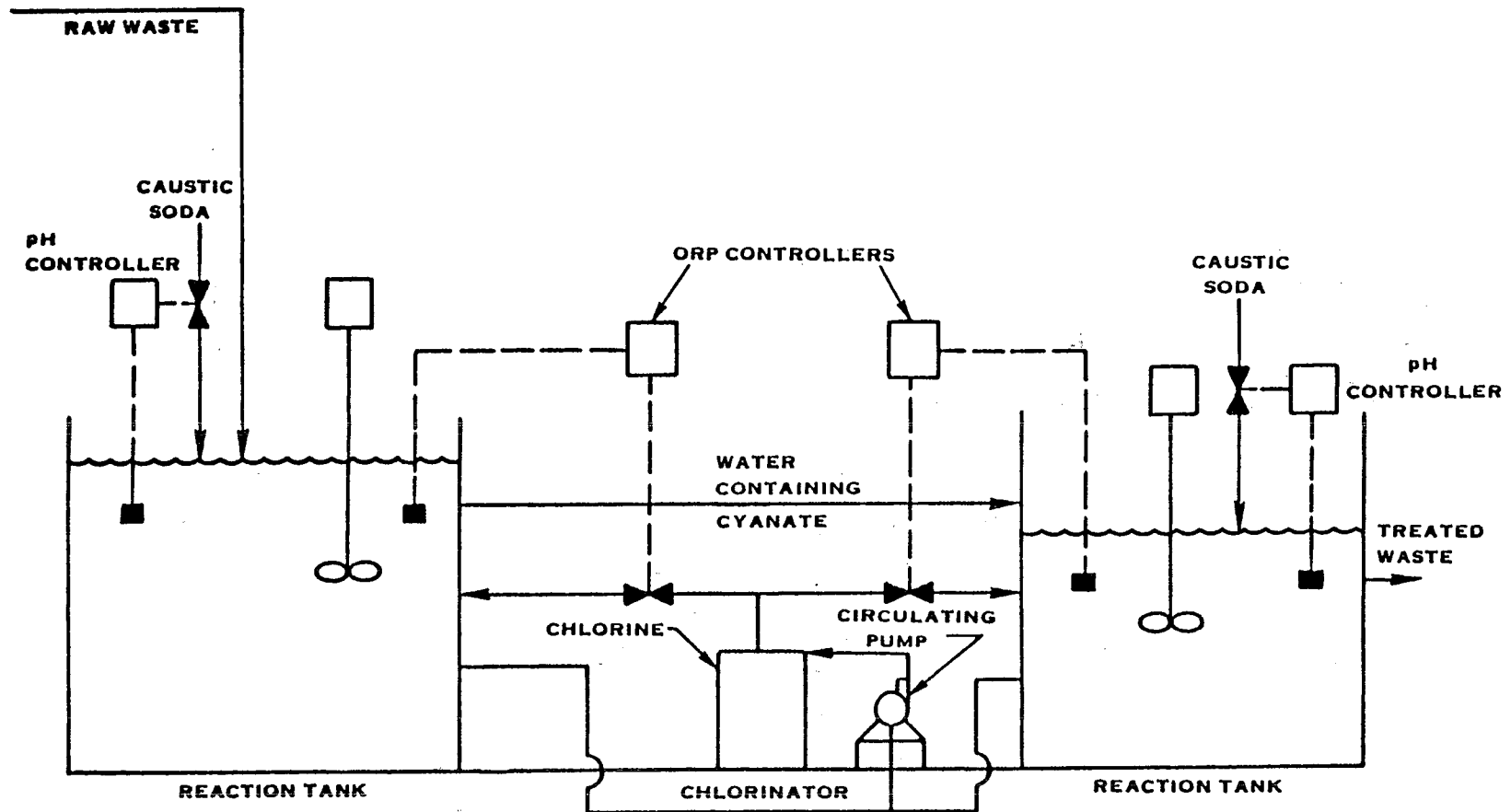

FIGURE VII - 19. TREATMENT OF CYANIDE WASTE BY ALKALINE CHLORINATION

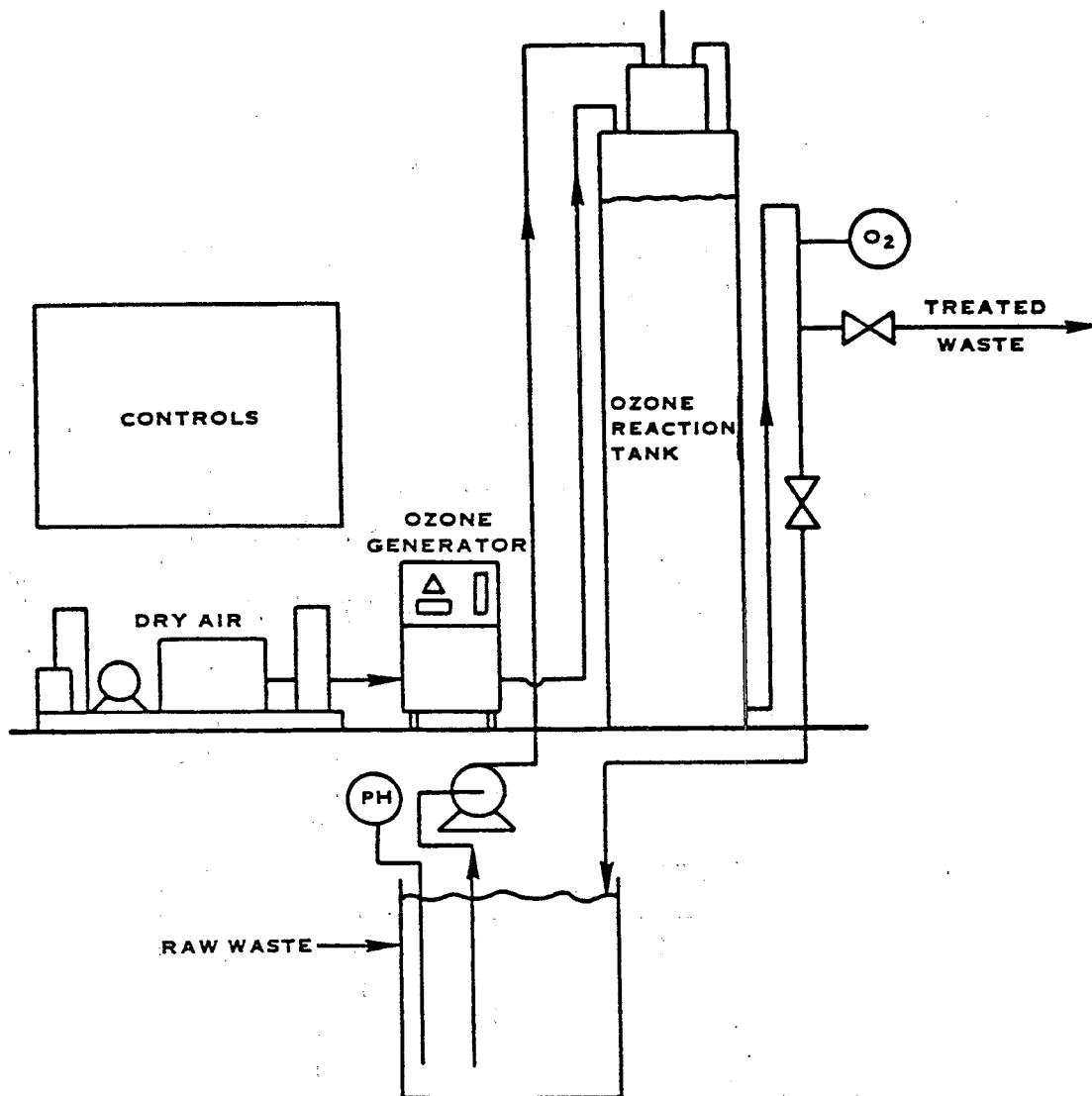

FIGURE VII - 20. TYPICAL OZONE PLANT FOR WASTE TREATMENT

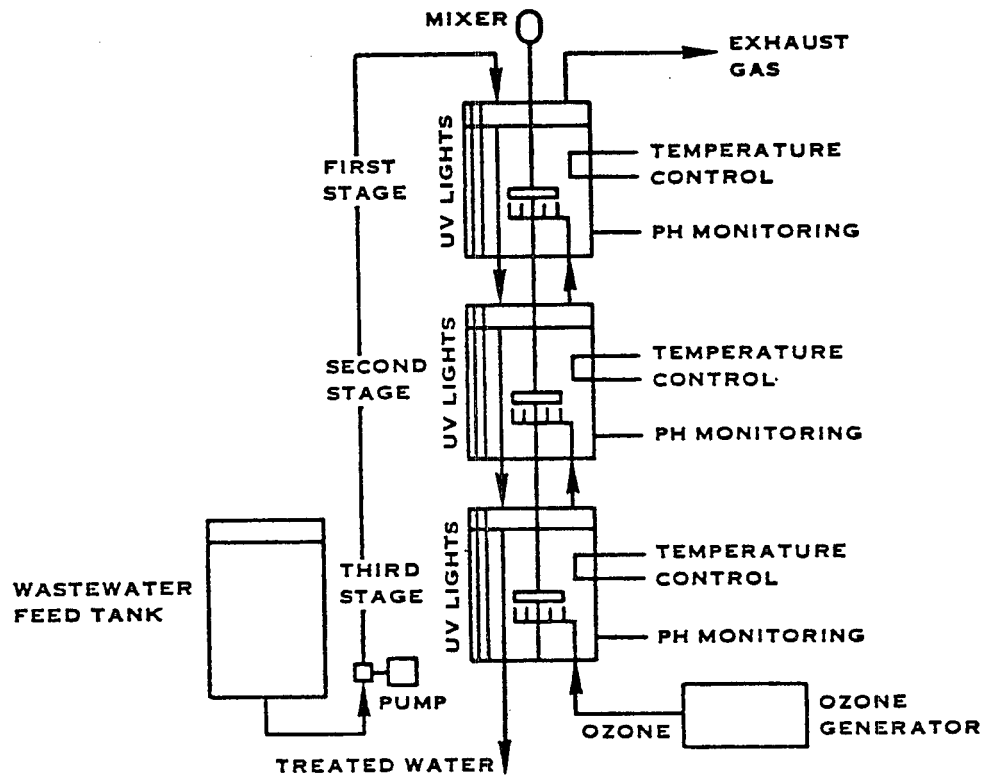

FIGURE VII - 21. UV/OZONATION

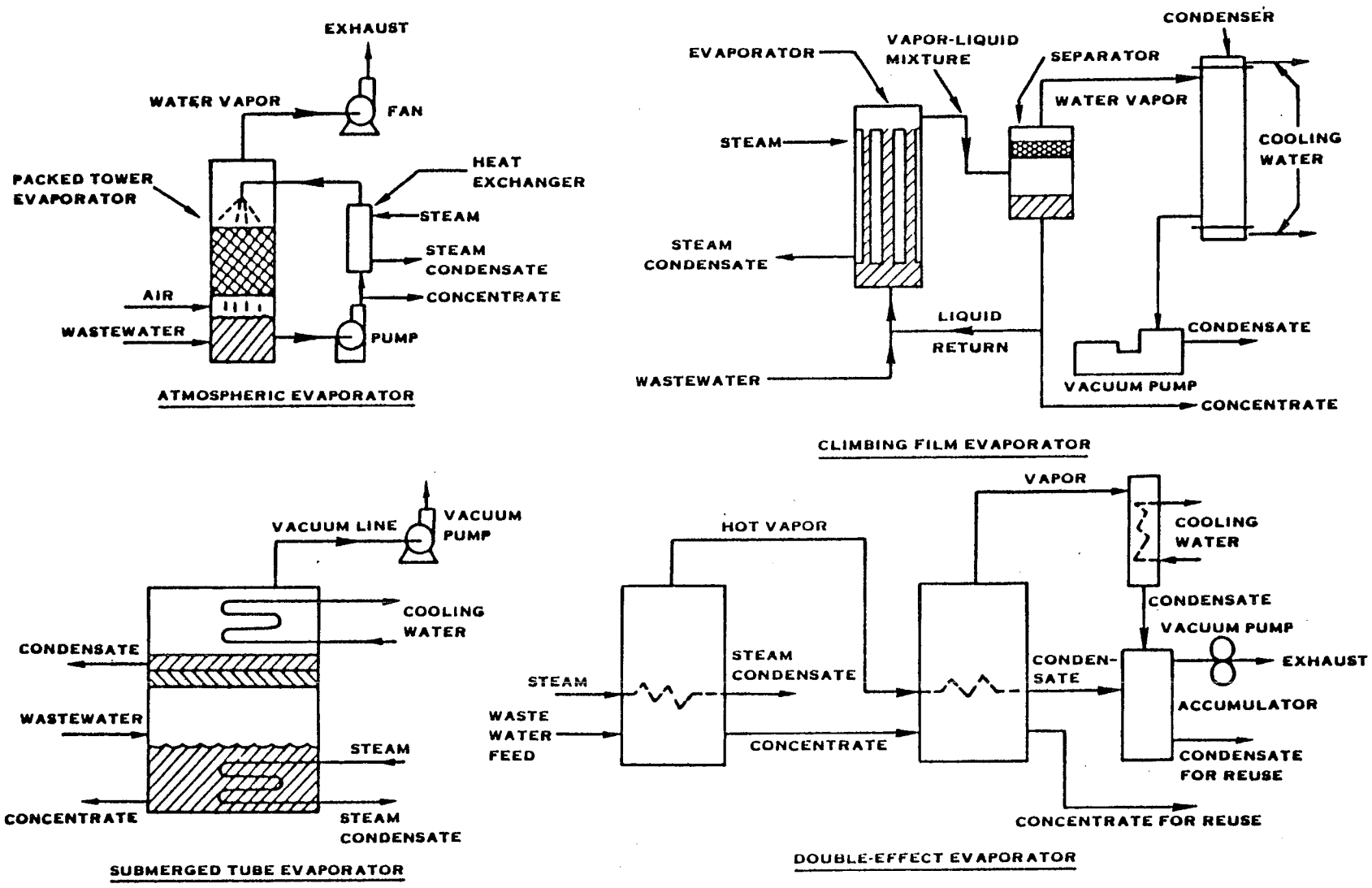

FIGURE VII - 22. TYPES OF EVAPORATION EQUIPMENT

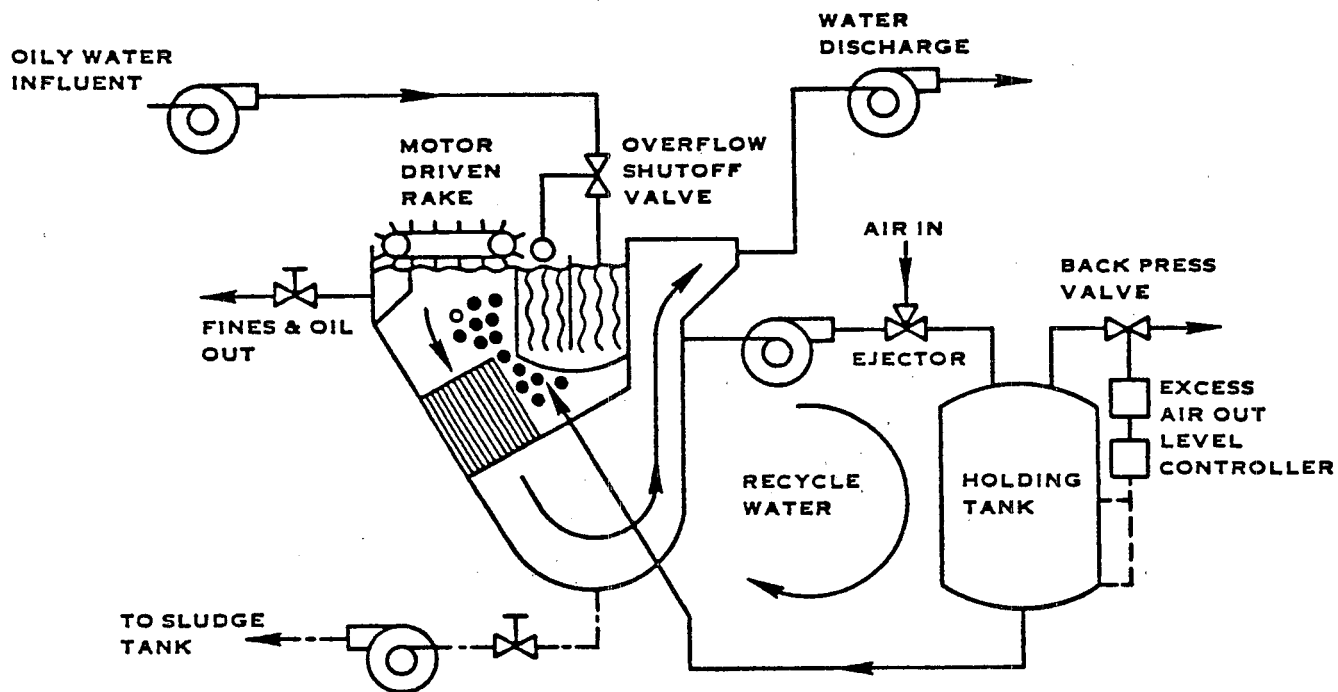

FIGURE VII - 23. DISSOLVED AIR FLOTATION

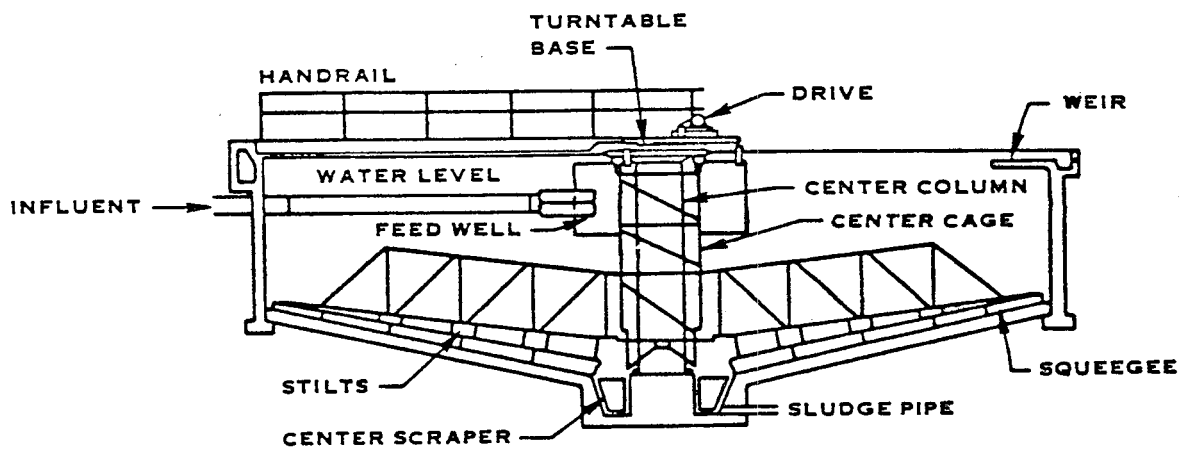
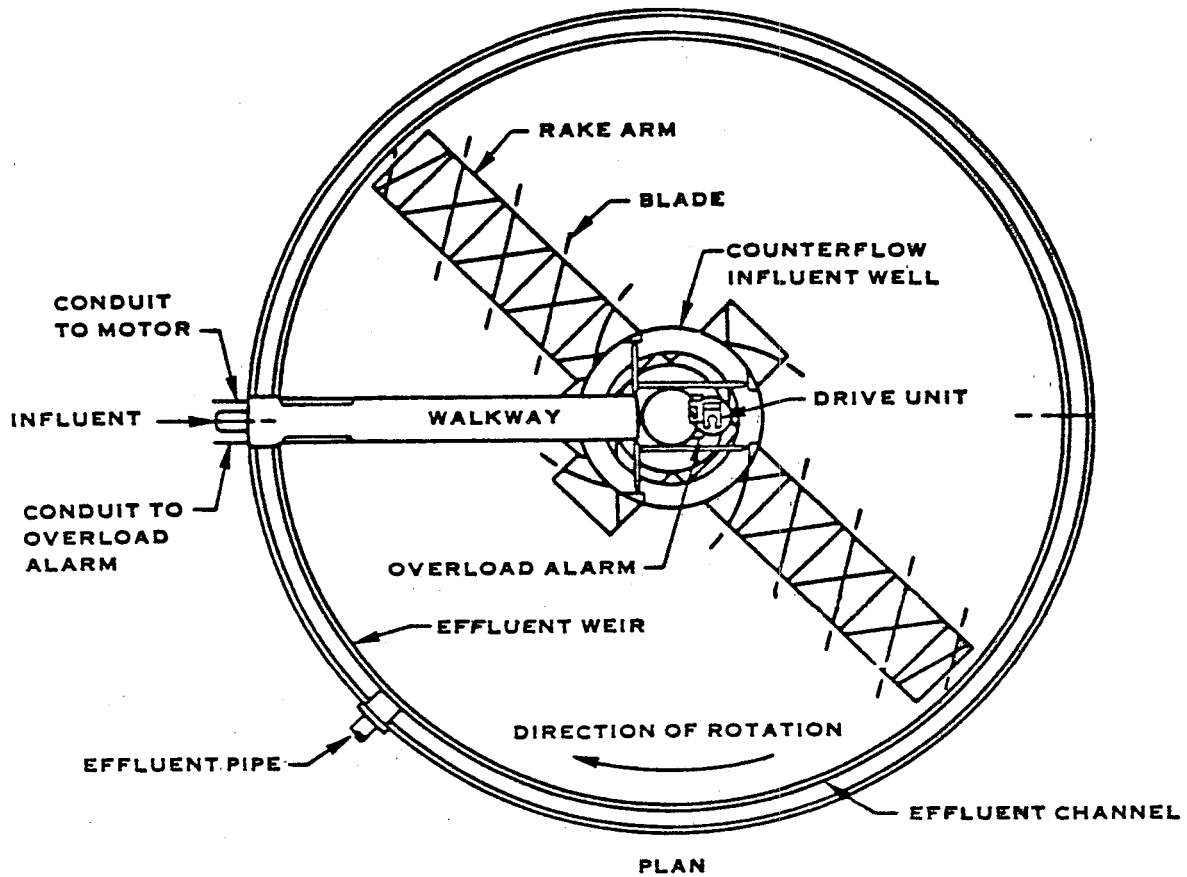

FIGURE VII - 24. GRAVITY THICKENING

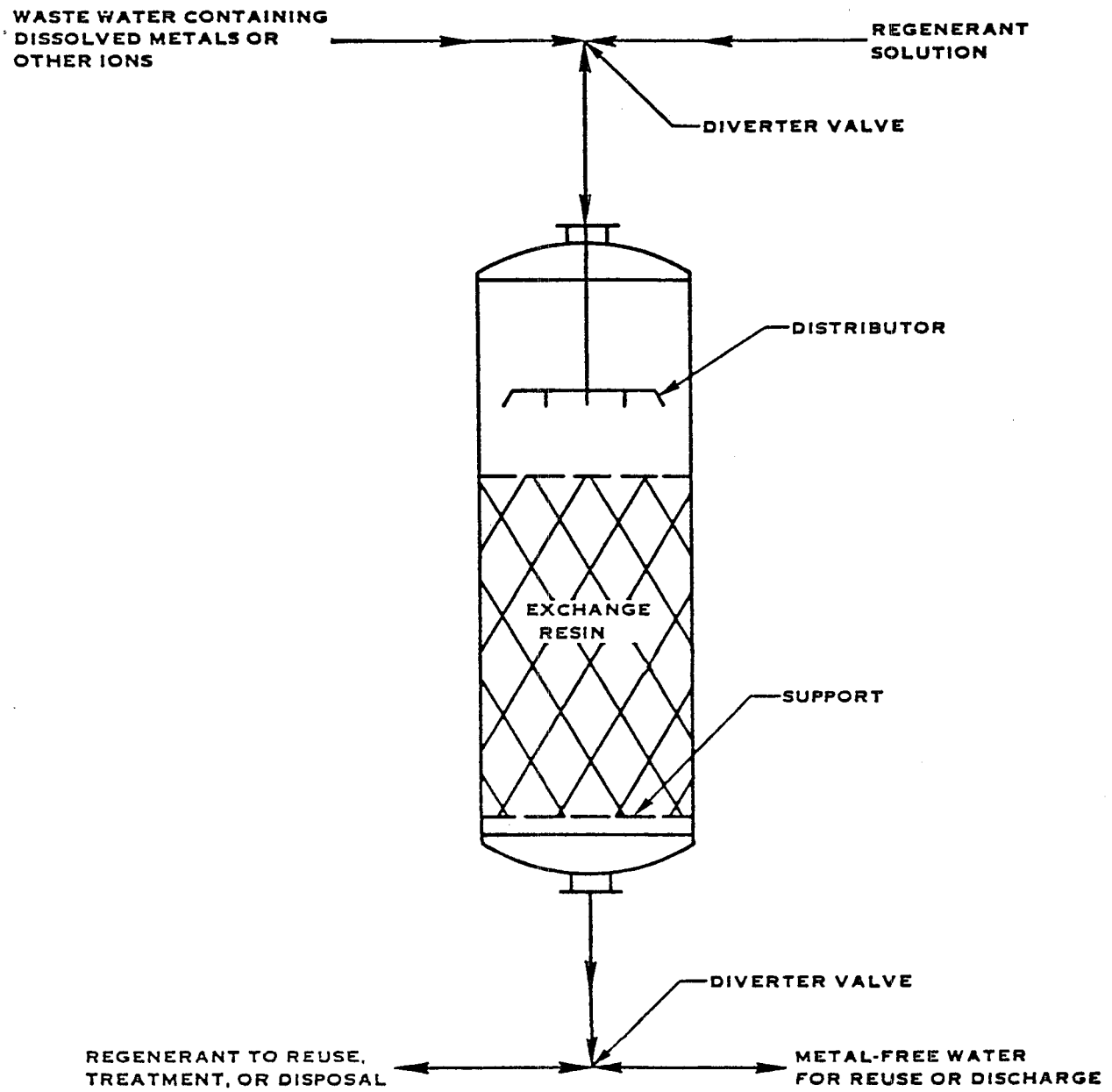

FIGURE VII - 25. ION EXCHANGE WITH REGENERATION

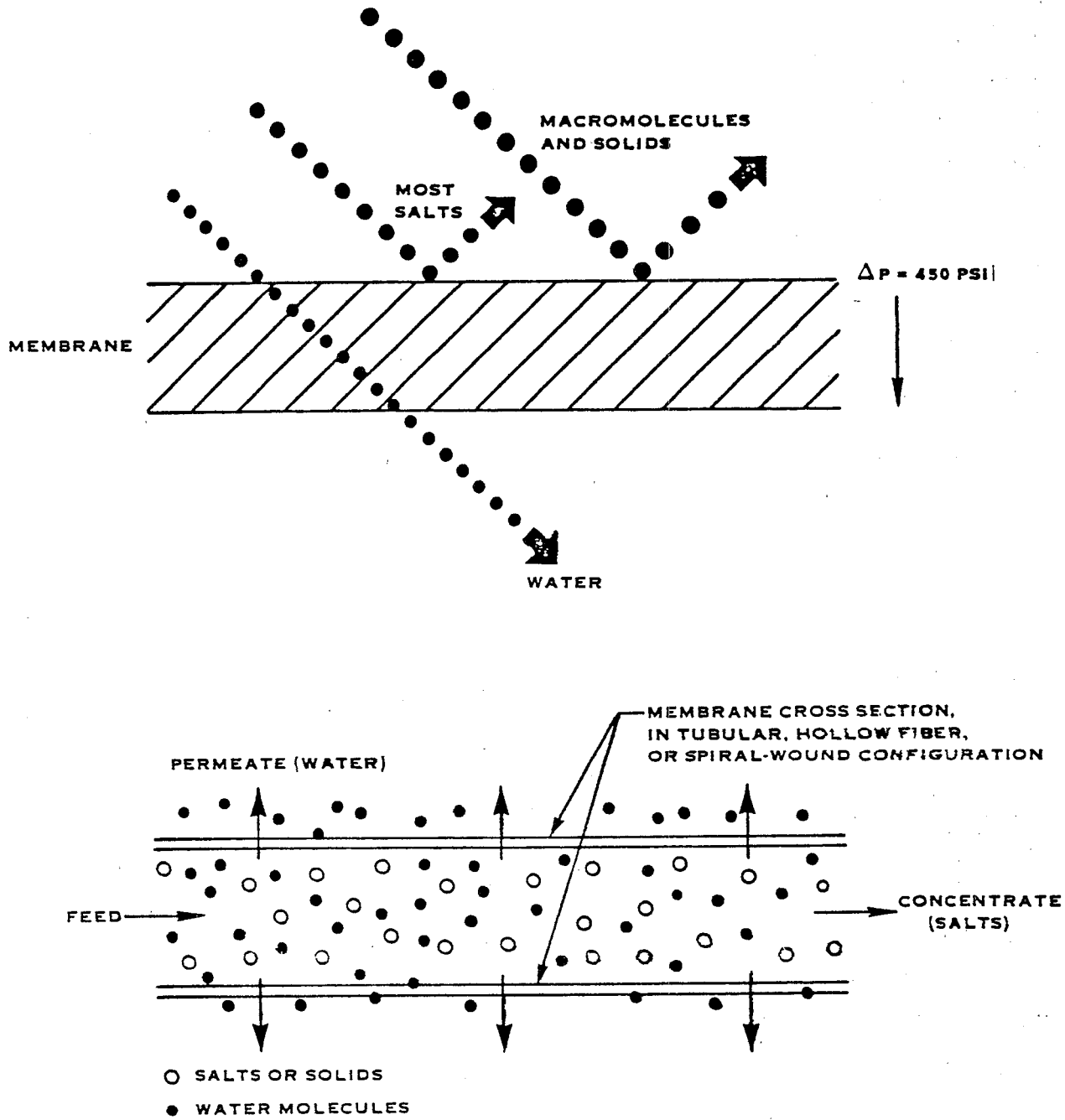

FIGURE VII - 26. SIMPLIFIED REVERSE OSMOSIS SCHEMATIC

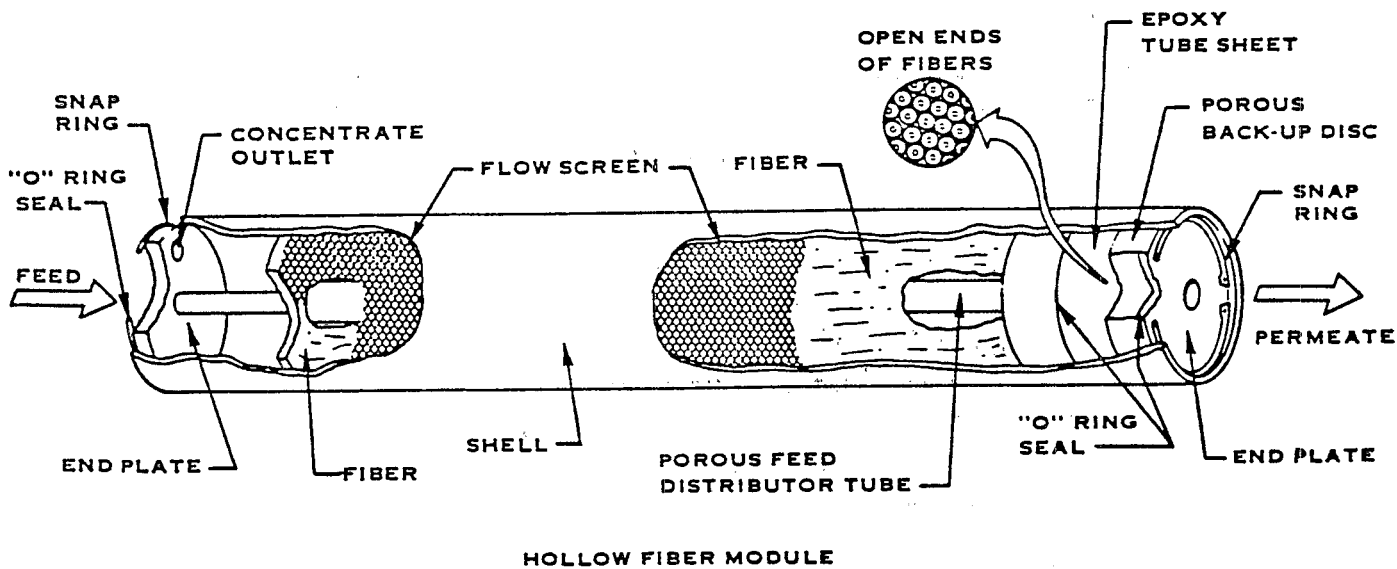
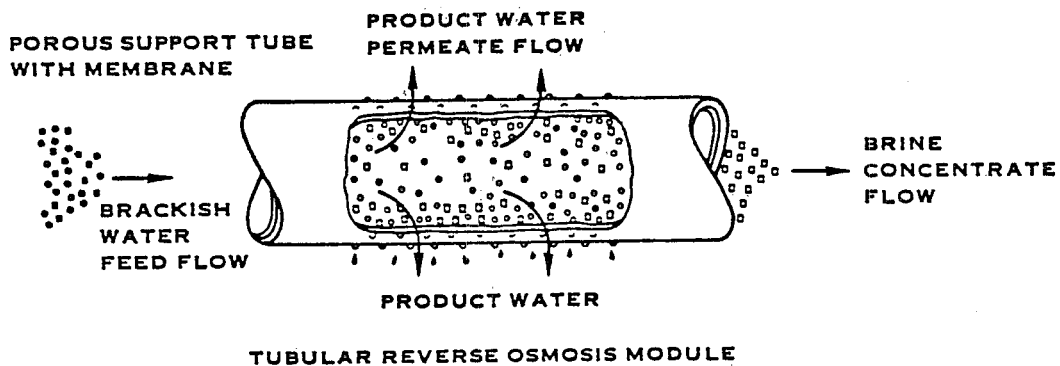
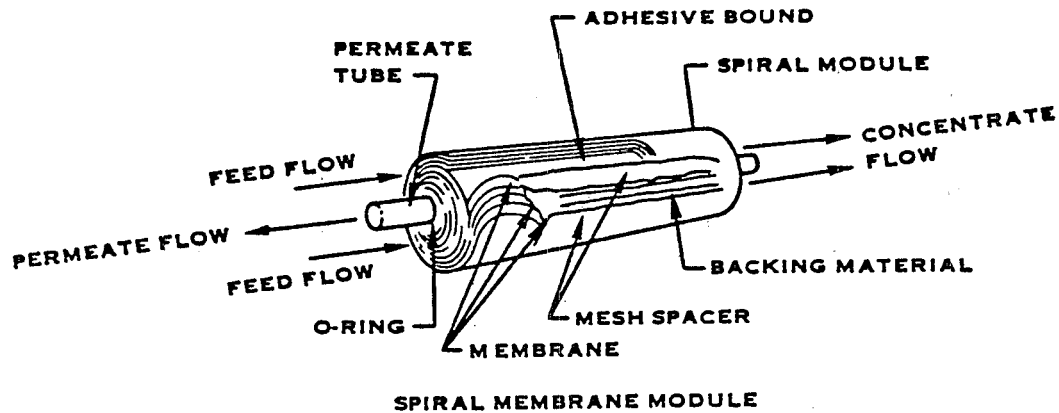

FIGURE VII - 27. REVERSE OSMOSIS MEMBRANE CONFIGURATIONS

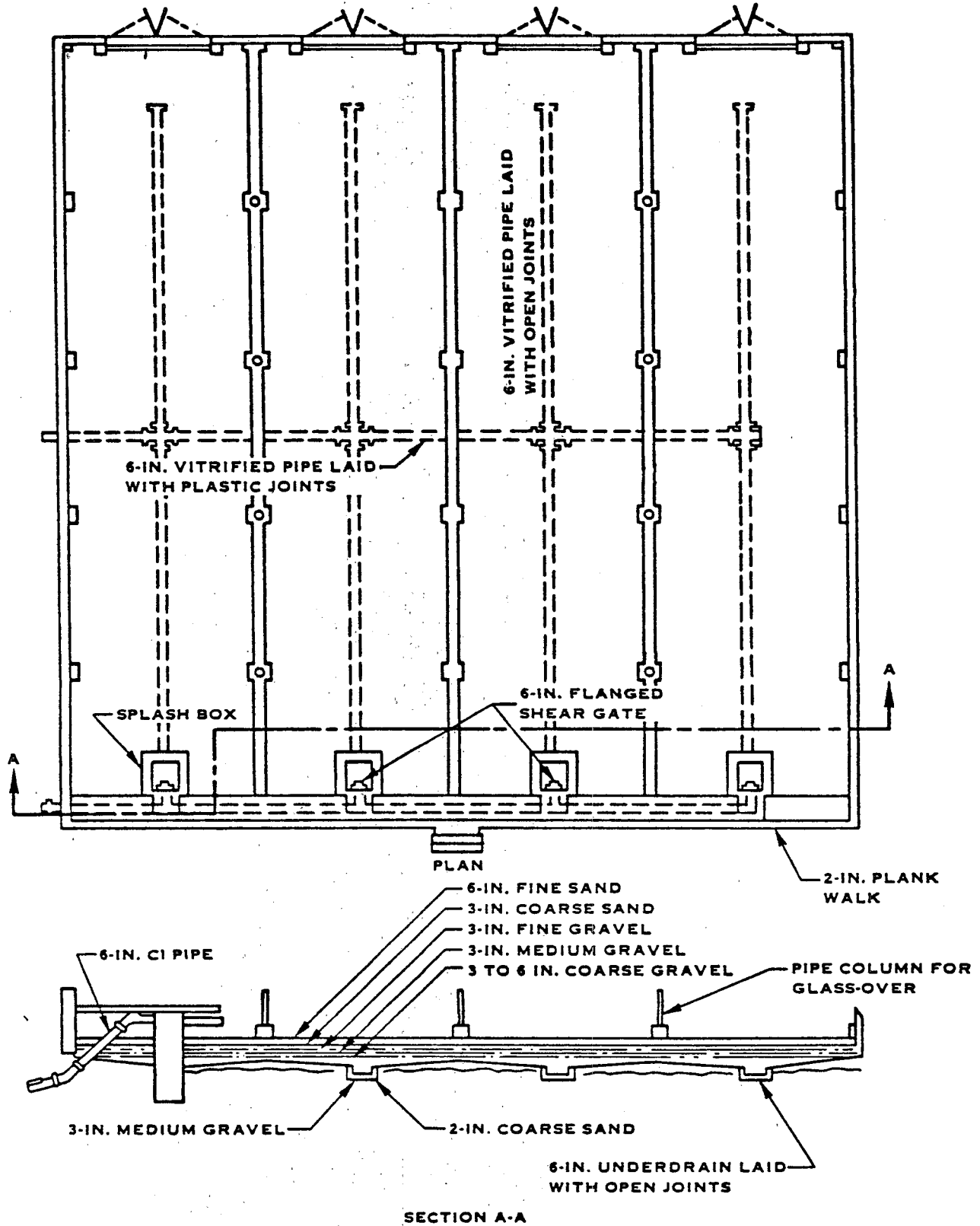

FIGURE VII - 28. SLUDGE DRYING BED

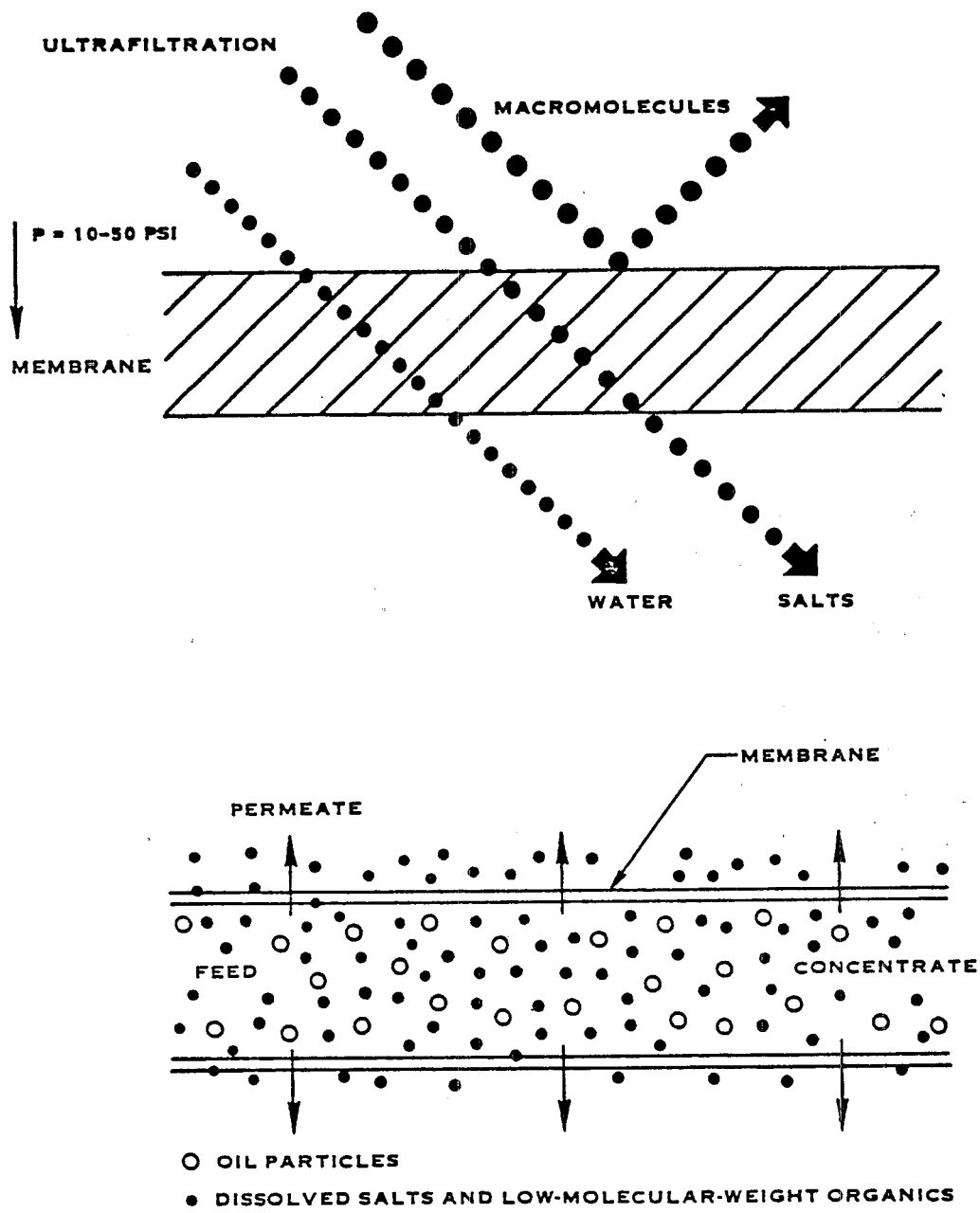

FIGURE VII - 29. SIMPLIFIED ULTRAFILTRATION FLOW SCHEMATIC

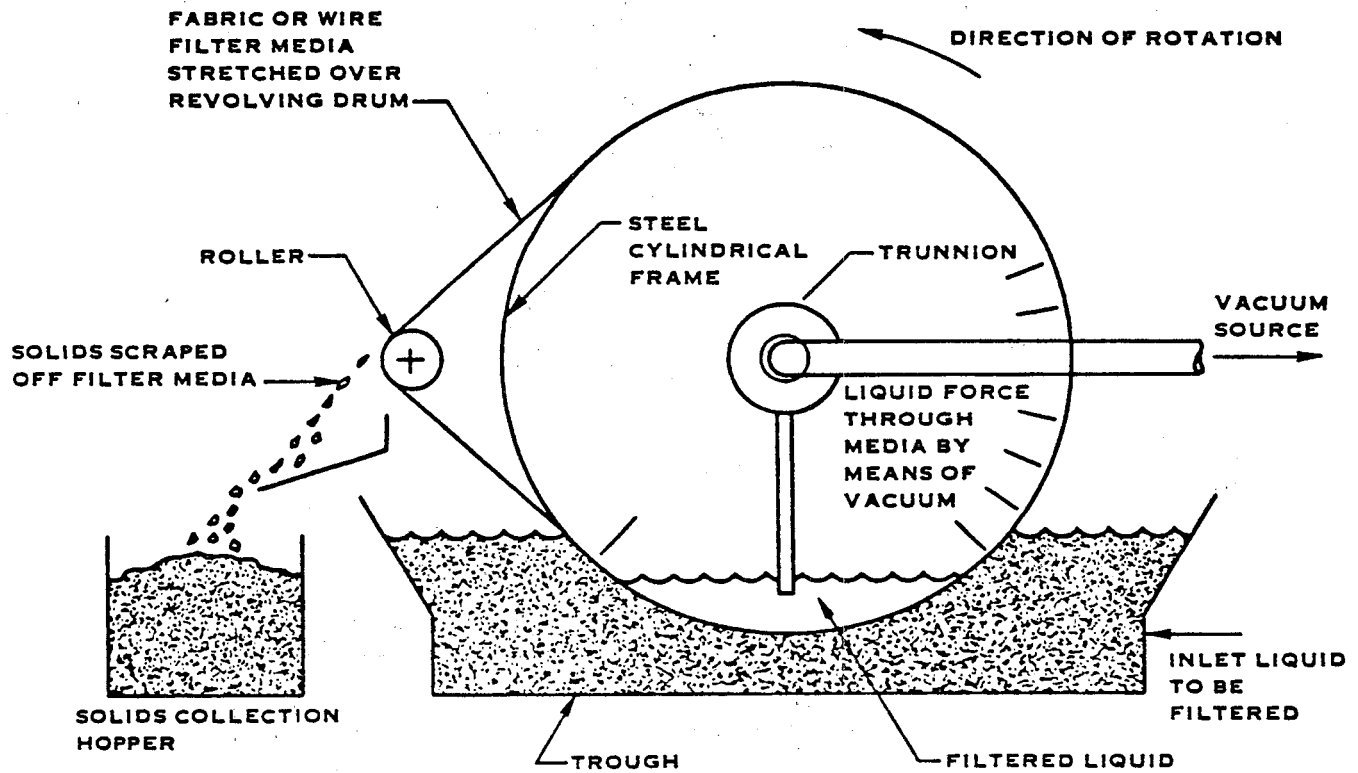

FIGURE VII - 30. VACUUM FILTRATION

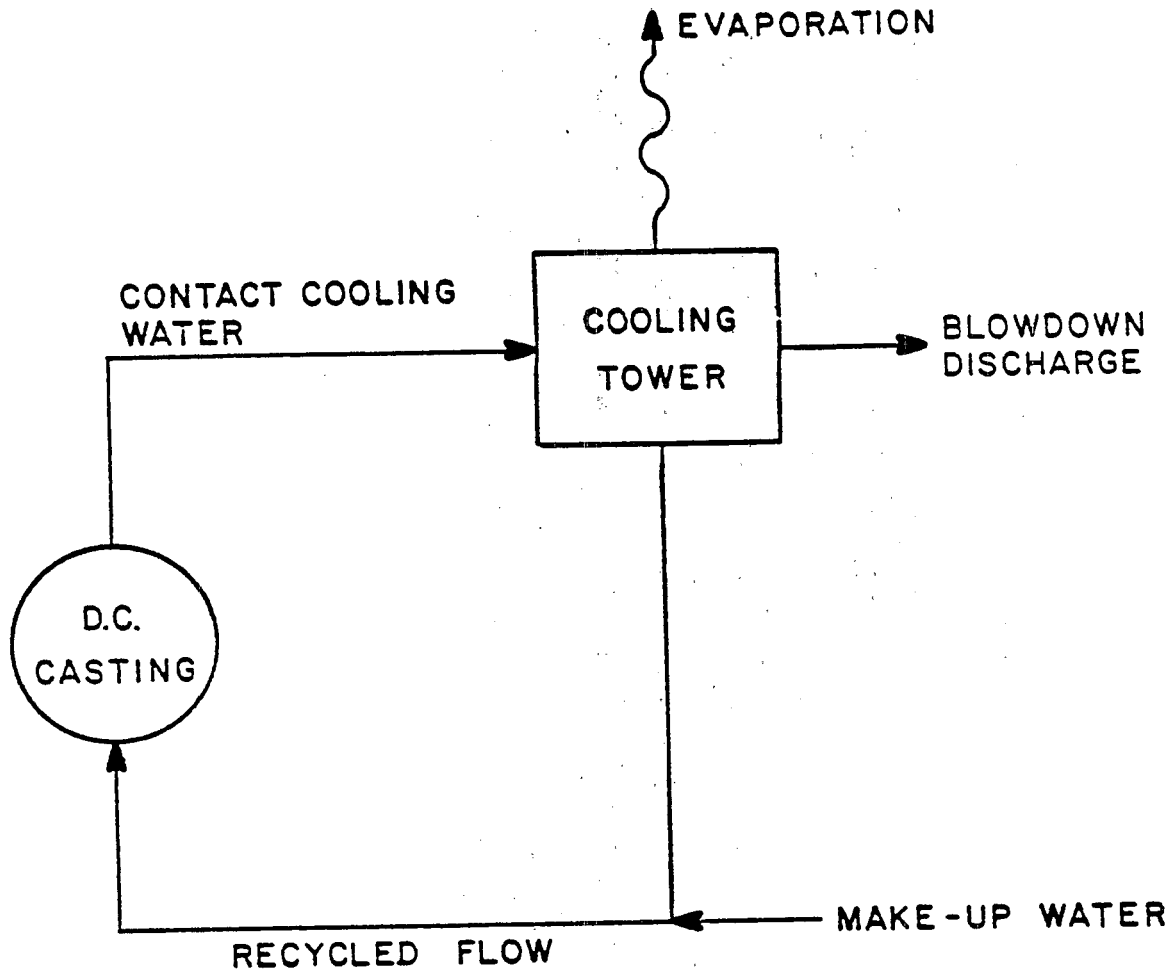

Figure VII-31

FLOW DIAGRAM FOR RECYCLING WITH A COOLING TOWER

SECTION VIII

COST OF WASTEWATER TREATMENT AND CONTROL

This section contains a summary of cost estimates, a discussion of the cost methodology used to develop these estimates, and descriptions of the equipment and assumptions for each individual treatment technology. These cost estimates, together with the estimated pollutant reduction performance for each treatment and control option presented in Sections IX, X, XI, and XII of the subcategory supplements, provide a basis for evaluating each regulatory option, as well as for identification of the best practicable technology currently available (BPT), best available technology economically achievable (BAT), best demonstrated technology (BDT), and the appropriate technology for pretreatment standards. The cost estimates also provide the basis for determining the probable economic impact of regulation on the category at different pollutant discharge levels. In addition, this section addresses nonwater quality environmental impacts of wastewater treatment and control alternatives, including air pollution, solid wastes, and energy requirements.

SUMMARY OF COST ESTIMATES

The total capital and annual costs of compliance with the promulgated regulation are presented by subcategory in Tables VIII-1 through VIII-3 (pages 327-329) for regulatory options BPT, BAT, and PSES, respectively. The number of direct and indirect discharging plants in each subcategory is also shown. The methodology used to obtain these plant cost estimates is described in the following sections.

COST ESTIMATION METHODOLOGY

Two general approaches to cost estimation are possible. The first is a plant-by-plant approach in which costs are estimated for each individual plant in the category. Alternatively, in a model plant approach, costs can be projected for an entire category (or subcategory) based on cost estimates for an appropriately selected subset of plants. The plant-by-plant cost estimation procedure is usually more accurate compared with the model plant approach because it affords a higher degree of flexibility and maximizes the use of plant specific data. For the nonferrous metals manufacturing category, the plant-by-plant approach was adopted.

For the primary aluminum, secondary aluminum, primary copper smelting, primary copper electrolytic refining, primary lead, primary zinc, primary columbium-tantalum, primary tungsten, secondary silver, secondary copper, secondary lead, and metallurgical acid plants subcategories, the Agency revised its cost estimation methodology between proposal and promulgation of effluent limitations.

The revisions are based on a more detailed engineering analysis of each plant so that estimated costs better represent actual cost to each plant for compliance with the regulations. The revised methodology also reflects the comments received by the Agency on its cost estimation approach. The pre- and post-proposal cost estimation methodologies are, in general, very similar. The major revisions in the methodology are listed below.

(1) The revised approach made greater use of plant-specific data for treatment system design and equipment information for costs.

(2) Treatment-in-place was considered.

(3) The method of determining the flow rate of wastewater into the treatment system was revised.

(4) Specific design and cost assumptions were revised.

(5) The method of calculating the pollutant loading in each waste stream was revised.

(6) The chemical precipitation system configuration was simplified.

(7) Costs for contract hauling of nonhazardous wastes were revised.

(8) Enclosure costs were revised.

To implement the revised approach, the wastewater characteristics and appropriate treatment technologies for the category were identified. These are discussed in Section V of each subcategory supplement and Section VII of this document, respectively. Based on a preliminary technical and economic evaluation, the model treatment systems were developed for each regulatory option from the available set of treatment processes. When these systems were established, a cost data base is developed containing capital and operating costs for each applicable technology. To apply this data base to each plant for cost estimation, the following steps were taken:

1. Define the components of the treatment system (e.g., chemical precipitation, multimedia filtration) and their sequence that are applicable to the waste streams under consideration.

2. Define the flows and pollutant concentrations of the waste streams entering the treatment system.

3. Estimate capital and annual costs for this treatment system.

4. Estimate the actual compliance costs by accounting for existing treatment in place.

5. Repeat steps 1-4 for each regulatory option.

Because of the large number of plants in the category and to provide a greater degree of accuracy, the above steps were accomplished by development of a computer-based cost estimation model for the nonferrous metals manufacturing category and related categories with similar treatment technology. This model represents the key element in the plant-by-plant cost estimation approach.

Each of the steps involved in the cost estimation methodology outlined above is described in more detail below.

Cost Data Base Development

A step required prior to cost estimation is the development of a cost data base, which includes the compilation of cost data and standardization of the data to a common dollar basis. Capital and annual cost data for the selected treatment processes were obtained from three sources: (1) equipment manufacturers and vendors, (2) literature data, and (3) cost data from existing plants. The major source of equipment costs was contacts with equipment vendors, while the majority of annual cost information was obtained from in-house files and the literature. Additional cost and design data were obtained from data collection portfolios when possible. The components of the cost estimates, the sources of cost data, and the update factors used for standardization (to March 1982 dollars) are described below.

Components of Costs

The components of the capital and annual costs and the terminology used in this study are presented here in order to ensure unambiguous interpretation of the cost estimates and cost curves included in this section.

Capital Costs. The total capital costs consist of two major components: direct, or total module capital costs and indirect, or system capital costs. The direct capital costs include:

- (1) Purchased equipment cost.
- (2) Delivery charges (based on a shipping distance of 500 miles), and
- (3) Installation (including labor, excavation, site work, and materials).

The direct components of the total capital cost are derived separately for each unit process, or treatment technology. Each unit process cost comprises individual equipment costs (e.g., pumps, tanks, feed systems, etc.). The correlating equations

used to generate the individual equipment costs are presented in Table VIII-4 (page 330).

Indirect capital costs consist of contingency, engineering and contractor fees. These indirect costs are derived from factored estimates (i.e., they are estimated as percentages of a subtotal of the total capital cost, as shown in Table VIII-5 (page 341)).

Annual Costs. The total annualized costs also consist of a direct and a system component as in the case of total capital costs. The components of the total annualized costs are listed in Table VIII-6 (page 340). Direct annual costs include the following:

Raw materials - These costs are for chemicals and other materials used in the treatment processes, which may include lime, caustic, sodium sulfide, activated carbon, sulfuric acid, ferrous sulfate, and polyelectrolyte.

Operating labor and materials - These costs account for the labor and materials directly associated with operation of the process equipment. Labor requirements are estimated in terms of hours per year. A labor rate of \$21 per hour was used to convert the hour requirements into an annual cost. This composite labor rate included a base labor rate of \$9 per hour for skilled labor, 15 percent of the base labor rate for supervision and plant overhead at 100 percent of the total labor rate. The base labor rate was obtained from the "Monthly Labor Review," which is published by the Bureau of Labor Statistics of the U.S. Department of Labor. For the metals industry, this wage rate was approximately \$9 per hour in March of 1982.

Maintenance labor and materials - These costs account for the labor and materials required for repair and routine maintenance of the equipment. They are based on information gathered from the open literature and from equipment vendors.

Energy - Energy, or power, costs are calculated based on total energy requirements (in kw-hrs). an electricity charge of \$0.0483/kilowatt-hour and an operating schedule of 24 hours/day, 250 days/year unless otherwise specified. The electricity charge rate (March 1982) is based on the average retail electricity prices charged for industrial service by selected Class A privately-owned utilities, as reported in the Department of Energy's Monthly Energy Review.

System annual costs include monitoring, insurance and amortization. Monitoring refers to the periodic analysis of wastewater effluent samples to ensure that discharge limitations are being met. The annual cost of monitoring was calculated using an analytical lab fee of \$120 per wastewater sample and a sampling frequency based on the wastewater discharge rate, as shown in Table VIII-7 (page 343). The values shown in Table

VIII-7 represent typical requirements contained in NPDES permits. For the economic impact analysis, the Agency also estimated monitoring costs based on 10 samples per month, which is consistent with the statistical basis for the monthly effluent limitations.

The cost of taxes and insurance is assumed to be one percent of the total depreciable capital investment.

Amortization costs, which account for depreciation and the cost of financing, were calculated using a capital recovery factor (CRF). A CRF value of 0.177 was used, which is based on an interest rate of 12 percent, and a taxable lifetime of 10 years. The CRF is multiplied by the total depreciable investment to obtain the annual amortization costs.

Standardization of Cost Data

All capital and annual cost data completed were standardized by adjusting to March 1982 dollars based on the following cost indices.

Capital Investment. Investment costs were adjusted using the EPA-Sewage Treatment Plant Construction Cost Index. The value of this index for March 1982 is 414.0.

Chemicals. The Chemical Engineering Producer Price Index for industrial chemicals was used. This index is published biweekly in Chemical Engineering magazine. The March 1982 value of this index is 362.6.

Energy. Power costs were adjusted by using the price of electricity on the desired date and multiplying it by the energy requirements for the treatment module in kw-hr equivalents. The industrial charge rate for electricity for March 1982 is \$0.0483 per kw-hr as mentioned previously in the annual costs discussion.

Labor. Annual labor costs were adjusted by multiplying the hourly labor rate by the labor requirements (in man-hours), if the latter is known. The labor rate for March 1982 was computed to be 21 dollars per hour as discussed above. In cases where the man-hour requirements are unknown, the annual labor costs are updated using cost indices. The ENR Skilled Labor Index was used for the primary aluminum, primary copper smelting, primary copper electrolytic refining, primary lead, primary zinc, primary columbium-tantalum, primary tungsten, secondary aluminum, secondary silver, secondary copper, secondary lead, and metallurgical acid plants subcategories. The value of this index for March 1982 is 3,256.23. For all other subcategories in this rulemaking the EPA-Sewage Treatment Plant Construction Cost Index was used. The value of this index for March 1982, is 414.0 as stated above.

Plant Specific Flowsheet

When the cost data base has been developed, the first step of the cost estimation procedure is the selection of the appropriate treatment technologies and their sequence for a particular plant. These are determined for a given option by applying the general treatment diagram for that subcategory to the plant, which is then modified as appropriate to reflect the treatment technologies that the plant will require. For instance, one plant in a subcategory may generate wastewater from a certain operation that requires oil-water separation. Another plant in the same subcategory may not generate this waste stream and thus does not require oil-water separation technology. The specific plant flowsheets will reflect this difference.

Wastewater Characteristics

Upon establishing the flowsheet required for a given plant, the next step is to define the influent waste stream characteristics (flow and pollutant concentrations).

The list of pollutants which may influence the design (and thus the cost) of the treatment system is shown in Table VIII-8. This list includes the conventional pollutants, and priority metal and selected nonconventional pollutants that are generally found in metal-bearing waste streams. Inclusion of these pollutants allows the model to account for the effects of varying influent concentrations upon the various wastewater treatment processes. For example, influent waste streams with high metals loadings require a greater volume of precipitant (such as lime) and generate a greater amount of sludge than wastestreams with lower metals concentrations.

The raw waste concentrations of pollutants present in the influent waste streams for cost estimation were based primarily on field sampling data. A production normalized raw waste value in milligrams of pollutant per metric ton of production was calculated for each pollutant by multiplying the measured concentration by the corresponding waste stream flow and dividing this result by the corresponding production associated with generation of the waste stream. These raw waste values are averaged across all sampled plants where the waste stream is found. These final raw waste values are used in the cost estimation procedure to establish influent pollutant loadings to each plant's treatment system. The underlying assumption in this approach is that the amount of pollutant that is discharged by a process is a function only of the amount of product that is generated by the process (or in some cases, the amount of raw material used in the process). The amount of water used in the processes is assumed to not have an affect on the pollutant quantity discharged. This assumption is also called the constant mass assumption since the mass of pollutant discharged remains the same even if the flow of water carrying the pollutant is changed.

The individual flows for cost estimation are determined for each waste stream. The procedure used to derive these flows is as

follows:

(1) The production normalized flows (l/kg) were determined for each waste stream based on production (kkg/yr) and current flow (l/yr) data obtained from each plant's dcp or trip report data where possible.

(2) This flow was compared to the regulatory flow allowance (l/kg) established by the Agency for each waste stream.

(3) The lower of the two flows was selected as the cost estimation flow. The flow in l/yr is calculated by multiplying the selected flow by the production associated with that waste stream.

(4) The regulatory flow was assigned to waste streams for which actual flow rate data were unavailable for a plant.

Treatment System Cost Estimation

Once the treatment system and waste stream characteristics have been defined, they can be used as input to the cost estimation step, which is based on the cost estimation model and general cost assumptions described below.

Cost Estimation Model

The computer-based cost estimation model was designed to provide conceptual wastewater treatment design and cost estimates based on wastewater flows, pollutant loadings, and unit operations that are specified by the user. The model was developed using a modular approach; that is, individual wastewater treatment processes such as gravity settling are contained in semi-independent entities known as modules. These modules are used as building blocks in the determination of the treatment system flow diagram. Because this approach allows substantial flexibility in treatment system cost estimation, the model did not require modification for each regulatory option.

Each module was developed by coupling design information from the technical literature with actual design data from operating plants. This results in a more realistic design than using either theoretical or actual data alone, and correspondingly more accurate cost estimates. The fundamental units for cost estimation are not the modules themselves but the components within each module. These components range in configuration from a single piece of equipment such as a pump to components with several individual pieces, such as a lime feed system. Each component is sized based on one or more fundamental parameters. For instance, the lime feed system is sized by calculating the lime dosage required to adjust the pH of the influent to 9 and precipitate dissolved pollutants. Thus, a larger feed system would be designed for a chemical precipitation unit treating effluent containing high concentrations to dissolved metals than for one treating effluent of the same flow rate but lower metals

loadings. This flexibility in design results in a treatment system tailored to each plant's wastewater characteristics.

The cost estimation model consists to four main parts, or categories of programs:

User input programs,
Design and simulation programs,
Cost estimation programs, and
Auxiliary programs.

A general logic diagram depicting the overall calculational sequence is shown in Figure VIII-1 (page 350).

The user input programs allow entry of all data required by the model, including the plant-specific flowsheet, flow and composition data for each waste stream, and specification of recycle loops. The design portion of the model calculates the design parameter for each module of the flowsheet based on the user input and material balances performed around each module. Figure VIII-2 (page 351) depicts the logic flow diagram for the design portion of the model.

The design parameters are used as input to the cost estimation programs to calculate the costs for each module equipment component (individual correlating cost equations were developed for each of these components). The total direct capital and annual costs are equal to the sum of the module capital and annual costs, respectively. System, or indirect costs (e.g., engineering, amortization) are then calculated (see Tables VIII-5, and VIII-6 (pages 341 and 342)) and added to the total direct costs to obtain the total system costs. The logic flow for the cost estimation programs is displayed in Figure VIII-3 (page 352). The auxiliary programs store and transfer the final cost estimates to data files, which are then used to generate final summary tables (see Table VIII-10, page 347, for a sample summary table).

General Cost Assumptions

The following general assumptions apply to cost estimation in all subcategories:

(1) Unless otherwise specified, all wastewater treatment sludges are considered to be nonhazardous.

(2) In cases in which a single plant has wastewater generating processes associated with different nonferrous metals manufacturing subcategories, costs are estimated for a single treatment system. In most cases, the combined treatment system costs are then apportioned between subcategories on a flow-weighted basis since hydraulic flow is the primary determinant of equipment size and cost. It is possible, however, for the combined treatment system to include a treatment module that is required by only one of the associated subcategories. In this

case, the total costs for that particular module are included in the costs for the subcategory which requires the module. Where the module in question involves flow reduction, the costs are apportioned based on an influent flow weighted basis. Such cost apportioning is essentially only a bookkeeping exercise to allocate costs because the total costs calculated for the plant remain the same.

(3) In most cases, where a plant has wastewater sources from the nonferrous metals manufacturing category and a category other than nonferrous manufacturing (for example, nonferrous forming) costs are calculated for segregating these different wastewaters. This means of cost estimation accounts for the possibility that respective regulations for each category are based on different technologies (and may control different pollutants).

Consideration of Existing Treatment

The cost estimates calculated by the model represent "greenfield costs" that do not account for equipment that plants may already have in place, i.e., these costs include existing treatment equipment. In order to estimate the actual compliance cost incurred by a plant to meet the effluent guidelines, "credit" should be given to account for treatment in place at that plant. This was accomplished by subtracting capital costs of treatment in-place (as estimated by the model) from the "greenfield costs" to obtain the actual or required capital costs of compliance. Annual costs associated with treatment in place (as estimated by the model), however, are not subtracted because these costs recur and must be borne by the facility each year. Further, inclusion of these annual costs ensures that EPA adequately considers the costs for proper operation of each module in the treatment system. For an example the reader is referred to Table VIII-10, (page 347 which presents compliance cost estimates for a plant that has chemical precipitation of sufficient capacity already in place.

Existing treatment is considered as such only if the capacity and performance of the existing equipment (measured in terms of estimated ability to meet the effluent limitations) is equivalent to that of the technologies considered by the Agency. The primary source of information regarding existing treatment was data collection portfolios (dcps).

General assumptions applying to all subcategories used for determining treatment in place qualifications in specific instances include:

(1) In cases in which existing equipment has adequate performance but insufficient capacity, the plant is assumed to comply by either installing additional required capacity to supplement the existing equipment or disregarding the existing equipment and installing new equipment to treat the entire flow. This selection was based on the lowest total annualized

cost.

(2) When a plant reported recycle of treatment plant sludges, capital and annual costs for sludge handling (vacuum filtration and contract hauling) are not included in the compliance costs. It is assumed that it is economical for the plant to practice recycle in this case, and therefore, the related costs are considered to be process associated, or a cost of doing business.

(3) Capital costs for flow reduction (via recycling) were not included in the compliance costs whenever the plant reported recycle to the stream, even if the specific method of recycle was not reported.

(g) Settling lagoons were assumed to be equivalent to vacuum filtration for dewatering treatment plant sludges. Thus, whenever a plant reported settling lagoons to be currently in use for treatment plant sludges, the capital costs of vacuum filtration were not included. It was assumed that annual vacuum filtration costs were comparable to those for operation of settling lagoons and were thus retained.

COST ESTIMATES FOR INDIVIDUAL TREATMENT TECHNOLOGIES

Treatment technologies have been selected from among the larger set of available alternatives discussed in Section VII after considering such factors as raw waste characteristics, typical plant characteristics (e.g., location, production schedules, product mix, and land availability), and present treatment practices. Specific rationale for selection is addressed in Sections IX, X, XI, and XII of this document and the subcategory supplements. Cost estimates for each technology addressed in this section include investment costs and annual costs for amortization, operation and maintenance, and energy.

The specific design and cost assumptions for each wastewater treatment module are listed under the subheadings to follow. Costs are presented as a function of influent wastewater flow except where noted in the unit process assumptions.

Costs are presented for the following control and treatment technologies:

- Cooling towers,
- Flow equalization,
- Cyanide precipitation and gravity settling,
- Ammonia steam stripping.
- Oil-water separation,
- Chemical precipitation and gravity settling,
- Sulfide precipitation and gravity settling,
- Vacuum filtration,
- Holding tanks,
- Multimedia filtration,
- Activated carbon adsorption,

Chemical oxidation, and
Contract hauling.

In addition, costs for the following items associated with compliance costs are also discussed:

Enclosures
Segregation

Cooling Towers

Cooling towers are used to reduce discharge flows by recycling cooling water waste streams. Holding tanks are used to recycle flows less than 3,400 liters per hour (15 gpm). This flow represents the effective minimum cooling tower capacity generally available.

The cooling tower capacity is based on the amount of heat removed, which takes into account both the design flow and the temperature decrease needed across the cooling tower. The influent flow to the cooling tower and the recycle rate are based on the assumptions given in Table VIII-9 (page 346). It should be noted that for BAT a cooling tower is not included for cases in which the actual flow is less than the reduced regulatory flow (BAT flow) since flow reduction is not required. The recycle ratios for waste streams undergoing flow reduction (based on cooling tower technology) are discussed in Section X of the pertinent subcategory supplement.

The temperature decrease is calculated as the difference between the hot water (inlet) and cold water (outlet) temperatures. The cold water temperature was assumed to be 29°C (85°F) and an average value calculated from sampling data is used as the hot water temperature for a particular waste stream. When such data were unavailable, or resulted in a temperature less than 35°C (95°F), a value of 35°C (95°F) was assumed, resulting in a cooling requirement for a 6°C (10°F) temperature drop. The other two design parameters, namely the wet bulb temperature (i.e., ambient temperature at 100 percent relative humidity) and the approach (the difference between the outlet water temperature and the wet bulb temperature), were assumed to be constant at 25°C (77°F) and 4°C (8°F), respectively.

For flow rates above 3,400 l/hr, a cooling tower is designed. The cooling tower is sized by calculating the required capacity in evaporative tons. Cost data were gathered for cooling towers up to 700 evaporative tons.

The capital costs of cooling tower systems include the following equipment:

Cooling tower (crossflow, mechanically-induced) and typical accessories

Piping and valves (305 meters (1,000 ft.)), carbon

steel)

Cold water storage tank (1-hour retention time)

Recirculation pump, centrifugal

Chemical treatment system (for pH, slime and corrosion control)

For heat removal requirements exceeding 700 evaporative tons, multiple cooling towers are designed.

The direct capital costs include purchased equipment cost, delivery, and installation. Installation costs for cooling towers are assumed to be 200 percent to the cooling tower cost based on information supplied by vendors.

Direct annual costs include raw chemicals for water treatment and fan energy requirements. Maintenance and operating labor was assumed to be constant at 60 hours per year. The water treatment chemical cost is based on a rate to \$220/1,000 lph (\$5/gpm) of recirculated water.

For small recirculating flows (less than 15 gpm), holding tanks were used for recycling cooling water. A holding tank system consists of a steel tank, 61 meters (200 feet) piping, and a recirculation pump. The capacity of the holding tank is based on the cooling requirements of the water to be cooled. Calculation of the tank volume is based on a surface area requirement of 0.025 m²/lph (60 ft²/gpm) to recirculated flow and constant relative tank dimensions.

Capital costs for the holding tank system include purchased equipment cost, delivery, and installation. The annual costs are attributable to the operation of the pump only (i.e., annual costs for tank and piping are assumed to be negligible).

Capital and annual costs for cooling towers and tanks are presented in Figure VIII-4 (page 353).

Flow Equalization

Flow equalization is accomplished through steel equalization tanks which are sized based on a retention time of 8 or 16 hours and an excess capacity factor of 1.2. A retention time of 16 hours was assumed only when the equalization tank preceded a chemical precipitation system with "low flow" mode, and the operating hours were greater than or equal to 16 hours per day. In this case, the additional retention time is required to hold wastewater during batch treatment, since treatment is assumed to require 16 hours and only one reaction tank is included in the "low flow" batch mode. Cost data were available for steel equalization tank up to a capacity of 1,893,000 liters (500,000 gallons); multiple units were required for volumes greater than 1,893,000 liters (500,000 gallons). Fiberglass tanks are used

for capacities below 24,000 gallons. The tanks are fitted with agitators with a horsepower requirement of 0.006 kw/1,000 liters (0.03 hp/1,000 gallons) of capacity to prevent sedimentation. An effluent transfer pump is also included in the equalization system. Cost curves for capital and annual costs are presented in Figure VIII-5 (page 354), for equalization at 8 hours and 16 hours retention time. Figure VIII-5 presents cost curves for capital and annual costs that are applicable to the following list of subcategories: primary aluminum, secondary aluminum, primary copper, secondary copper, primary lead, primary zinc, primary tungsten, primary columbium-tantalum, secondary silver, and secondary lead.

Cyanide Precipitation and Gravity Settling

Cyanide precipitation is a two-stage process to remove complexed and uncomplexed cyanide as a precipitate. In the first step, the wastewater is contacted with an excess of $\text{FeSO}_4 \cdot 7\text{H}_2\text{O}$ at pH 9.0 to ensure that all cyanide is converted to the complexed form:

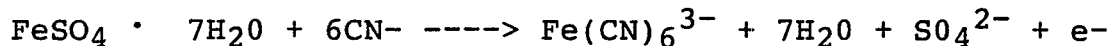

The hexacyanoferrate is then routed to the second stage, where additional $\text{FeSO}_4 \cdot 7\text{H}_2\text{O}$ and acid are added. In this stage, the pH is lowered to 4.0 or less, causing the precipitation of $\text{Fe}_3(\text{Fe}(\text{CN})_6)_2$ (Turnbull's blue) and its analogues:

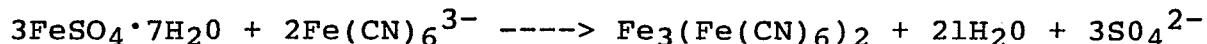

A chemical defoamer may be added prior to pH adjustment to inhibit foaming, as carbon dioxide degassing may occur when the pH is lowered.

The blue precipitate is settled and the overflow is discharged for further treatment.

Since the complexation step adjusts the pH to 9, metal hydroxides will precipitate. These hydroxides may either be settled and removed at pH 9 or resolubilized at pH 4 in the final precipitation step and removed later in a downstream chemical precipitation unit. Advantages of removal of the metal hydroxides include reduced acid requirements in the final precipitation step, since the metals will resolubilize when the pH is adjusted to 4. However, the hydroxide sludge may be classified as hazardous due to the presence of cyanide. In addition, the continuous mode of operation requires an additional clarifier between the complexation and precipitation step. These additional costs make the settling of metal hydroxides economically unattractive in the continuous mode. However, the batch mode requires no extra equipment. Consequently, metal hydroxide sludge removal in this case is desirable before the precipitation step. Therefore, the batch cyanide precipitation step settles two sludges: metal hydroxide sludge (at pH 9) and

cyanide sludge (at pH 4).

Costs were estimated for both batch and continuous systems with the operating mode selected on a least cost basis. The equipment and assumptions used in each mode are detailed below.

Costs for the complexation step in the continuous mode are based on the following:

- (1) Ferrous sulfate feed system
 - ferrous sulfate steel
 - storage hoppers with dust collectors (largest hopper size is 170 mg (6,000 ft³); 15 days storage)
 - enclosure for storage tanks
 - volumetric feeders (small installations)
 - mechanical weigh belt feeders (large installations)
 - dissolving tanks (5-minute detention time, 6 percent solution)
 - dual-head diaphragm metering pumps
 - instrumentation and controls
- (2) Lime feed system
 - hydrated lime
 - feeder
 - slurry mix tank (5-minute retention time)
 - feed pump
 - instrumentation (pH control)
- (3) H₂SO₄ feed system (used when influent pH is >9)
 - 93 percent H₂SO₄ delivered in bulk or in drums
 - acid storage tank (15 days retention) when delivered in bulk
 - metering pump (standby provided)
 - pipe and valves
 - instrumentation and controls
- (4) Reaction tank and agitator (fiberglass, 60-minute retention time, 20 percent excess capacity, agitator mount, concrete slab)
- (5) Effluent transfer pump

For the primary aluminum subcategory, the lime feed system was replaced with a caustic feed system. This system consisted of day tanks (2) with mixers and feeders for feed rates less than 200 lbs/day, a fiberglass tank with a 15-day storage capacity for feed rates greater than 200 lbs/day, chemical metering pumps, pipes and valves, and instruments and controls.

Costs for the second step (precipitation) in the continuous mode are based on the following equipment:

- (1) FeSO₄ feed system - as above
- (2) H₂SO₄ feed system - as above
- (3) Polymer feed system
 chemical mix tank with agitator
 chemical metering pump
 system storage hopper
- (4) Reaction tank with agitator (fiberglass, 30-minute retention time, 20 percent excess capacity, agitator mount, concrete slab)
- (5) Clarifier
 sized based on 709 lph/m² (17.4 gph/ft²), 3 percent solids in underflow
 steel or concrete, above ground
 support structure, sludge scraper, and other internals
 center feed
- (6) Effluent transfer pump
- (7) Sludge transfer pump

A chemical defoaming system may be included. Defoaming costs consist of the antifoam chemical and the chemical feed system.

Operation and maintenance costs for continuous mode cyanide precipitation include labor requirements to operate and maintain the system, electric power for mixers, pumps, clarifier and controls, and treatment chemicals. Electrical requirements are also included for the chemical storage enclosures for lighting and ventilation and in the case of caustic storage, heating. The following assumptions are used in establishing OEM costs for the complexation step in the continuous mode:

- (1) Ferrous sulfate feed system
 stoichiometry of 1 mole
 FeSO₄ 7H₂O to 6 moles CN-
 1.5 times stoichiometric dosage to
 drive reaction to completion
 operating labor at 10 min/feeder/shift
 maintenance labor at 8 hr/yr for liquid metering
 pumps
 power based on agitators, metering pumps
 maintenance materials at 3 percent of capital cost
 chemical cost at \$0.1268 per kg (\$0.0575 per lb)
- (2) Lime feed system

dosage based on pH and metals content to raise pH to 9
 operating and maintenance labor requirements are based on 20 min/day; in addition, 8 hr/7,260 kg (8 hr/16,000 lbs) are assumed for delivery of hydrated lime
 maintenance materials cost is estimated as 3 percent of the purchased equipment cost
 chemical cost of lime is based on \$0.0474/kg (\$0.0215 per lb) for hydrated lime delivered in bags

(3) Acid feed system (if required)

dosage based on pH and metals to bring pH to 9
 labor unloading - 0.25 hr/drum acid
 labor operation - 15 min/day
 annual maintenance - 8 hrs
 power (includes metering pump)
 maintenance materials - 3 percent of capital cost
 chemical cost at \$0.082 per kg (\$0.037 per lb)

(4) Reaction tank with agitator

operating and maintenance labor at 120 hrs/yr
 maintenance materials
 -- tank: 2 percent of tank capital cost
 -- pump: 5 percent of pump capital cost
 For the primary aluminum subcategory
 maintenance materials costs were estimated at 5 percent of capital cost.
 power based on agitator (70 percent efficiency) at 0.099 kW/1,000 liters (0.5 hp/1,000 gallons) of tank volume

(5) Pump

operating labor at 0.04 hr/operating day
 maintenance labor at 0.005 hr/operating hour for flow <22,700 liters per hour (100 gpm)
 maintenance materials at 5 percent of capital cost
 power based on pump hp

For the primary aluminum subcategory, the lime feed system was replaced by a caustic feed system. The costs for the caustic feed system are as follows:

Caustic feed system

dosage based on pH and metals content to raise pH to 9
 maintenance materials - 3 percent of manufactured equipment cost (excluding storage tank cost)

labor unloading
--dry NaOH - 8 hrs/16,000 lbs
--liquid 50 percent NaOH - 5 hrs/50,000 lbs
labor operation (dry NaOH only) 10 min/day/feeder
labor operation for metering pump - 15 min/day
annual maintenance - 8 hrs
power [includes metering pump hp, instrumentation
and control, volumetric feeder (dry NaOH)]
chemical cost at \$0.183 per lb

The following assumptions were used for the continuous mode precipitation step:

(1) Ferrous sulfate feed system

stoichiometric dosage based on 3 moles
 $\text{FeSO}_4 \cdot 7\text{H}_2\text{O}$ to 2 moles of iron-complexed
cyanide ($\text{Fe}(\text{CN})_6^{3-}$)
total dosage is 10 times stoichiometric dosage
based on data from an Agency treatability study
other assumptions as above

(2) H_2SO_4 feed system

dosage based on pH adjustment to 4 and
resolubilization of the metal hydroxides
from the complexation step
other assumptions as above

(3) Polymer feed system

2 mg/l dosage
operation labor at 134 hr/yr, maintenance labor at
32 hr/yr
maintenance materials at 3 percent of the capital
cost
energy at 17,300 kWh/yr
chemical cost at \$4.96/kg (\$2.25/lb)

(4) Reaction tank with agitator

see assumptions above

(5) Clarifier

sized based on 417 gpd/ft², 3 percent solids
in underflow
maintenance materials range from 0.8 percent to
2 percent as a function of increasing size
labor - 150 to 500 hr/yr (depending on size)
power - based on horsepower requirements for
sludge pumping and sludge scraper drive unit

(6) Effluent transfer pump

see assumptions above

(7) Sludge pump

sized on underflow from clarifier
 operation and maintenance labor varies with flow
 rate
 maintenance materials - varies from 7 percent to
 10 percent of capital cost depending on flow rate

The batch mode cyanide precipitation step accomplishes both complexation and precipitation in the same vessel. Costs for batch mode cyanide complexation and precipitation are based on the following equipment:

(1) Ferrous sulfate addition

from bags
 added manually to reaction tank

(2) Lime addition

from bags
 added manually to reaction tank

(3) H₂SO₄ addition

from 208 liter (55 gallon) drums
 stainless steel valve to control flow

(4) Reaction tank and agitator (fiberglass, 8.5 hour minimum retention time, 20 percent excess capacity, agitator mount, concrete slab)

(5) Pump

effluent transfer pump
 sludge pump

Operation and maintenance costs for batch mode cyanide complexation and precipitation include costs for the labor required to operate and maintain the equipment, electrical power for agitators, pumps, and controls, and chemicals. The assumptions used in estimating costs are as follows:

(1) Ferrous sulfate addition

stoichiometric dosage

--complexation: 1 mole FeSO₄·7H₂O per 6 moles
 CN⁻

--precipitation: 3 moles FeSO₄·7H₂O per 2
 moles of the iron cyanide complex (Fe(CN)₆³⁻)
 actual dosage in excess of stoichiometric
 complexation: 1.5 times stoichiometric dosage added

precipitation: 10 times stoichiometric dosage added
 operating labor at 0.25 hr/batch
 chemical cost at \$0.1268/kg (\$0.0575/lb)
 no maintenance labor or materials or power costs

(2) Lime addition

dosage based on pH and metals content to raise pH
 to 9
 operating labor at 0.25 hr/batch
 chemical cost at \$0.0474/kg (\$0.0215/lb)
 no maintenance labor or materials or power costs

(3) H₂SO₄ addition

dosage based on pH and metals content to lower pH
 to 9 (for complexation if required) and/or to lower
 pH to 4 (for precipitation)
 operating labor at 0.25 hr/batch
 chemical cost at \$0.082/kg (\$0.037/lb)
 no maintenance labor or materials or power costs

(4) Reaction tank with agitator

maintenance materials
 --tank: 2 percent of tank capital cost
 --pump: 5 percent of pump capital cost
 power based on agitator (70 percent efficiency) at
 0.099 kW/1,000 liters (0.5 hp/1,000 gallons) of tank
 volume

(5) Pumps

effluent transfer pump
 --operating labor at 0.04 hr/operating day
 --maintenance labor at 0.005 hr/operating day (or
 flows < 22,700 l/hr (100 gpm)
 --maintenance materials at 5 percent of capital cost
 --power based on pump hp
 sludge pump
 --operation and maintenance costs vary with flow
 rate
 --maintenance materials costs vary from 7 to 10 per-
 cent of capital cost depending on flow rate

Capital and annual costs for continuous and batch mode cyanide precipitation are presented in Figure VIII-6 (page 355). Figure VIII-6 presents cost curves for capital and annual costs that are applicable to the following list of subcategories: primary aluminum, secondary aluminum, primary copper, secondary copper, primary lead, primary zinc, primary tungsten, primary columbium-tantalum, secondary silver, and secondary lead.

Ammonia Steam Stripping

Ammonia removal using steam is a proven technology that is in use in many industries. Ammonia is more volatile than water and may be removed using steam to raise the temperature and preferentially evaporate the ammonia. This process is most economically done in a plate or packed tower, where the method of contacting the liquid and vapor phases reduces the steam requirement.

The pH of the influent wastewater is raised to approximately 12 to convert almost all of the ammonia present to molecular ammonia (NH_3) by the addition of lime. The water is then preheated before it is sent to the column. This process takes place by indirectly contacting the influent with the column effluent and with the gaseous product via heat exchangers. The water enters the top of the column and travels downward. The steam is injected at the bottom and rises through the column, contacting the water in a countercurrent fashion. The source of the steam may be either reboiled wastewater or another steam generation system, such as the plant boiler system.

The presence of solids in the wastewater, both those present in the influent and those which may be generated by adjusting the pH (such as metal hydroxides), necessitates periodic cleaning of the column. This requires an acid cleaning system and a surge tank to hold wastewater while the column is being cleaned. The column is assumed to require cleaning approximately once per week based on the demonstrated long-term cleaning requirements of an ammonia stripping facility. The volume of cleaning solution used per cleaning operation is assumed to be equal to the total volume of the empty column (i.e., without packing).

For the estimation of capital and annual costs, the following pieces of equipment were included in the design of the steam stripper:

(1) Packed tower

3-inch Rashig rings
hydraulic loading rate = 2 gpm/ft²
height equivalent to a theoretical plate = 3ft

(2) pH adjustment system

lime feed system (continuous) - see chemical precipitation section for discussion
rapid mix tank, fiberglass (5-minute retention time)
agitator (velocity gradient is 300 ft/sec/ft)
control system
pump

(3) Heat exchangers (stainless steel)

(4) Reboiler (gas-fired)

(5) Acid cleaning system

batch tank, fiberglass
 agitator (velocity gradient is 60/sec.)
 metering pump

(6) Surge tank (8-hour retention time)

The direct capital cost to the lime feed system was based on the chemical feed rate as noted in the discussion on chemical precipitation. Sulfuric acid used in the acid cleaning system was assumed to be added manually, requiring no special equipment. Other equipment costs were direct or indirect functions of the influent flow rate. Direct annual costs include operation and maintenance labor for the lime feed system, heat exchangers and reboiler, the cost of lime and sulfuric acid, maintenance materials, energy costs required to run the agitators and pumps, and natural gas costs to operate the reboiler. The total direct capital and annual costs are presented in Figure VIII-7 (page 356).

Oil-Water Separation

Oil skimming costs apply to the removal of free (non-emulsified) oil using either a coalescent plate oil-water separator or a belt skimmer located on the equalization tank. The latter is applicable to low oily waste flows (less than 189 liters per day) whereas the coalescent plate separator is used for oily flows greater than 189 liters/day (50 gpd).

Although the required coalescent plate separator capacity is dependent on many factors, the sizing was based primarily on the influent wastewater flow rate, with the following design values assumed for the remaining parameters of importance:

Parameter	Design Value
Specific gravity of oil	0.85
Operating temperature ($^{\circ}\text{F}$)	68
Influent oil concentration (mg/l)	30,000
Effluent oil concentration (mg/l)	10.0

Extreme operating conditions, such as influent oil concentrations greater than 30,000 mg/l, or temperatures much lower than 20°C (68°F) were accounted for in the sizing of the separator. Additional capacity for such extreme conditions was provided using correlations developed from actual oil separator performance data.

The capital and annual costs of oil-water separation include the following equipment:

Coalescent plate separator with automatic shutoff
 valve and level sensor

Oily waste storage tanks (2-week retention time)
Oily waste discharge pump
Effluent discharge pump

Influent flow rates up to 159,100 l/hr (700 gpm) are treated in a single unit. Flows greater than this require multiple units.

The direct annual costs for oil-water separation include the cost of operating and maintenance labor and replacement parts. Annual costs for the coalescent plate separators alone are minimal and involve only periodic cleaning and replacement of the plates.

If the amount of oil discharged is 189 liters/day (50 gpd) or less, it is more economical to use a belt skimmer rather than a coalescent plate separator. This belt skimmer may be attached to the equalization basin which is usually necessary to equilibrate flow surges. The belt skimmer-equalization basin configuration is assumed to achieve 10 mg/l oil in the effluent.

The equipment included in the belt oil skimmer and associated design parameters and assumptions are presented below.

1. Belt oil skimmer
12-inch width
6-foot length
2. Oily waste storage tank
2-week storage
fiberglass

Capital costs for belt skimmers were obtained from published vendor quotes. Annual costs were estimated from the energy and operation and maintenance requirements. Energy requirements are calculated from the skimmer motor horsepower. Operating labor is assumed constant at 26 hours per year. Maintenance labor is assumed to require 24 labor hours per year and belt replacement once a year. Cost curves for capital and annual costs of oil-water separation are presented in Figure VIII-8 (page 357). Figure VIII-8 presents cost curves for capital and annual costs that are applicable to the following list of subcategories: primary aluminum, secondary aluminum, primary copper, secondary copper, primary lead, primary zinc, primary tungsten, primary columbium-tantalum, secondary silver, and secondary lead.

Chemical Precipitation and Gravity Settling

Chemical precipitation using lime or caustic followed by gravity settling is a fundamental technology for metals removal. In practice, quicklime (CaO), hydrated lime (Ca(OH)₂), or caustic (NaOH) can be used to precipitate toxic and other metals. Where lime is selected, hydrated lime is generally more economical for low lime requirements since the use of slakers, which are

necessary for quicklime usage, is practical only for large volume applications of lime (greater than 50 lbs/hr). The chemical precipitant used for compliance cost estimation depends on a variety of factors in the subcategory being considered. The basis for the chemical precipitant (lime or caustic) used for a particular subcategory may be found in the appropriate supplement.

Lime or caustic is used to adjust the pH of the influent waste stream to a value of approximately 9, at which optimum overall precipitation of the metals as metal hydroxides is assumed to occur. The chemical precipitant dosage is calculated as a theoretical stoichiometric requirement based on the pH and the influent metals concentrations. In addition, particular waste streams may contain significant amounts of fluoride, such as those found in the secondary tin and primary columbium-tantalum subcategories. The fluoride will form calcium fluoride (CaF_2) when combined with free calcium ions which are present if lime is used as the chemical precipitant. The additional sludge due to calcium fluoride formation is included in the sludge generation calculations. In cases where the calcium consumed by calcium fluoride formation exceeds the calcium level resulting from dosing for pH adjustment and metal hydroxide formation, the additional lime needed to consume the remaining fluoride is included in the total theoretical dosage calculation. The total chemical dosage requirement is obtained by assuming an excess of 10 percent of the theoretical dosage. The effluent concentrations are generally based on the Agency's combined metals data base treatment effectiveness values for chemical precipitation technology described in Section VII (see Table VII-21, page 248).

The costs of chemical precipitation and gravity settling are based on one of three operating modes, depending on the influent flow: continuous, "normal" batch, or "low flow" batch. The use of a particular mode for cost estimation purposes is determined on a least cost (total annualized) basis. The economic break-point between continuous and normal batch was estimated to be 10,600 l/hr (46.7 gpm). Below 2,200 l/hr, it was found that the low flow batch was the most economical. The direct capital and annual costs are presented in Figure VIII-9 (page 358 for all three operating modes. Figure VIII-9 presents cost curves for capital and annual costs that are applicable to the following list of subcategories: primary aluminum, secondary aluminum, primary copper, secondary copper, primary lead, primary zinc, primary tungsten, primary columbium-tantalum, secondary silver, and secondary lead.

Continuous Mode. For continuous operation, the following equipment is included in the determination of capital and annual costs:

- (1) Chemical precipitant feed system (continuous)

lime

--bags (for hydrated lime) or storage units (30-day

storage capacity) for quicklime
 --slurry mix tank (5-minute retention time) or
 slaker
 --feed pumps (for hydrated lime slurry) or gravity
 feed (for quicklime slurry)
 --instrumentation (pH control)
 caustic
 --day tanks (2) with mixers and feeders for feed
 rates less than 200 lbs/day; fiberglass tank with
 15-day storage capacity otherwise
 --chemical metering pumps
 --pipe and valves
 --instrumentation (pH control)

(2) Polymer feed system

storage hopper
 chemical mix tank with agitator
 chemical metering pump

(3) Reaction system

rapid mix tank. fiberglass (5-minute retention time)
 agitator (velocity gradient is 300 ft/sec/ft)
 instrumentation and control

(4) Gravity settling system

clarifier, circular, steel (overflow rate of 360
 gpd/ft. and underflow solids of 5 percent) were
 used for most subcategories. However, for the
 following subcategories, an overflow rate of
 500 gpd/ft² and an underflow solids of 3 percent
 was used: primary aluminum, secondary aluminum,
 primary copper, secondary copper, primary lead,
 primary zinc, primary tungsten, primary
 columbium-tantalum, secondary silver, and secondary
 lead.

(5) Sludge pump

Ten percent of the clarifier underflow stream is recycled to the
 pH adjustment tank to serve as seed material for the incoming
 waste stream.

The direct capital costs of the chemical precipitant and polymer
 feed are based on the respective feed rates (dry lbs/hr), which
 are dependent on the influent waste stream characteristics. The
 flexibility of this feature (i.e., costs are independent of other
 module components) was previously noted in the description of the
 cost estimation model. The remaining equipment costs (e.g., for
 tanks, agitators, pumps) were developed as a function of the
 influent flow (either directly or indirectly, when coupled with
 the design assumptions).

Direct annual costs for the continuous system are based on the following assumptions:

(1) Lime feed system

Operating and maintenance labor requirements are based on 3 hrs/day for the quicklime feed system and 20 min/day for the hydrated lime feed system. In addition, 5 hrs/50,000 lbs are required for bulk delivery of quicklime and 8 hrs/16,000 lbs are assumed for delivery of hydrated lime.

Maintenance materials cost is estimated as 3 percent of the purchased equipment cost.

Chemical cost of lime is based on \$47.40/kg (\$43.00/ton) for hydrated lime delivered in bags and \$34.50/kg (\$31.30/ton) for quicklime delivered on a bulk basis. These costs were obtained from the Chemical Weekly Reporter (March 1982).

(2) Caustic feed system

Labor for unloading of dry NaOH requires 8 hours per 16,000 lbs delivered. Liquid 50 percent NaOH requires 5 hours per 50,000 lbs.

Operating labor for dry NaOH feeders is 10 min/day/feeder

Operating labor for metering pump is 15 min/day

Maintenance materials cost is assumed to be 3 percent of the purchased equipment cost.

Energy cost is based on the horsepower requirements for the feed pumps and mixers. Energy requirements generally represent less than 5 percent of the total annual costs for the caustic feed system.

Chemical cost is \$1.183 per lb.

(3) Polymer feed system

Polymer requirements are based on a dosage of 2 mg/l.

The operating labor is assumed to be 134 hrs/yr, which includes delivery and solution preparation requirements. Maintenance labor is estimated at 32 hrs/yr.

Energy costs for the feed pump and mixer are based on 17,300 kw-hr/yr.

Chemical cost for polymer is based on \$5.00/kg (\$2.225/lb).

(4) Reaction system

Operating and maintenance labor requirements are 120 hrs/yr.

Pumps are assumed to require 0.005 hrs of maintenance/operating hr (for flows less than 100 gpm) or 0.01 hrs/operating hr (flows greater than 100 gpm), in addition to 0.05 hrs/operating day for pump operation.

Maintenance materials costs are estimated as 5 percent of the purchased equipment cost.

Energy costs are based on the power requirements for the pump (function of flow) and agitator (0.06 hp/1,000 gal). An agitator efficiency of 70 percent was assumed.

(5) Gravity settling system

Annual operating and maintenance labor requirements range from 150 hrs for the minimum size clarifier (300 ft.²) to 500 hrs for a clarifier of 30,000 ft.². In addition, labor hrs for operation and maintenance of the sludge pumps were assumed to range from 55 to 420 hrs/yr, depending on the pump capacity (10 to 1,500 gpm).

Maintenance material costs are estimated as 3 percent of the purchased equipment cost.

Energy costs are based on power requirements for the sludge pump and rake mechanism.

Normal Batch Mode. The normal batch treatment system, which is used for flows between 2,200 and 10,600 l/hr, consists of the following equipment:

(1) Chemical precipitant feed system

lime (batch)

--slurry tank (5-minute retention time)

--agitator

--feed pump

caustic (batch)

--fiberglass tank (1-week storage)

--chemical metering pump

(2) Polymer feed system

chemical mix tank

agitator

chemical metering pump

(3) Reaction system

reaction tanks (minimum of 2) (8-hour retention time each)

agitators (2) (velocity gradient is 300 ft/sec/ft)
pH control system

The reaction tanks used for pH adjustment are sized to hold the wastewater volume accumulated for one batch period (assumed to be 8 hours). The tanks are arranged in a parallel setup to allow treatment in one tank while wastewater is accumulated in the other tank. A separate gravity settler is not necessary since settling can occur in the reaction tank after precipitation has taken place. The settled sludge is then pumped to the dewatering stage if necessary.

Direct annual costs for the batch treatment system are based on the following assumptions:

(1) Lime feed system (batch)

Operating labor requirements range from 15 to 60 min/batch, depending on the feedrate (5 to 1,000 lbs of hydrated lime/batch).
Maintenance labor is assumed to be constant at 52 hrs/yr (1 hr/week).
Energy costs for the agitator and feed pump are assumed to be negligible.
Chemical costs are based on the use of hydrated lime (see continuous feed system assumptions).

(2) Caustic feed system (batch)

Operating labor requirements are based on 30 min/metering pump/shift.
Maintenance labor requirements are 16 hrs/metering pump/yr.
Energy costs are assumed to be negligible.
Chemical costs are based on the use of 50 percent liquid caustic solution (see continuous feed system).

(3) Polymer feed system (batch)

Polymer requirements are based on a dosage of 2 mg/l.
Operating and maintenance labor are assumed to require 50 hrs/yr.
Chemical cost for polymer is based on \$5.00/kkg (\$2.25/lb).

(4) Reaction system

Required operating labor is assumed to be 1 hr/batch (for pH control, sampling, valve operation, etc.)
Maintenance labor requirements are 52 hrs/yr.
Energy costs are based on power requirements for operation of the sludge pump and agitators.

Low-Flow Batch Mode. For small influent flows (less than 2,200 l/hr), it is more economical on a total annualized cost basis to select the "low flow" batch treatment system. The lower flows allow an assumption of up to five days for the batch duration, or holding time, as opposed to eight hours for the normal batch system. However, whenever the total batch volume (based on a five-day holding time) exceeds 10,000 gallons, which is the maximum single batch tank capacity, the holding time is decreased accordingly to maintain the batch volume under this level. The cutoff value used for maximum single batch tank capacity for the following list of subcategories was 25,000 gallons, rather than 10,000 gallons: primary aluminum, secondary aluminum, primary copper, secondary copper, primary lead, primary zinc, primary tungsten, primary columbium-tantalum, secondary silver and secondary lead. Capital costs for the low flow system are based on the following equipment:

(1) Reaction system

reaction/holding tank (5-day or less retention time)
agitator
transfer pump

(2) Polymer feed system (batch)

chemical mix tank (5-day retention time)
agitator
chemical metering pump

The polymer feed system is included for the low flow system for manufacturing processes operating in excess of 16 hours per day. The addition of polymer for plants operating 16 hours or less per day is assumed to be unnecessary due to the additional settling time available.

Only one tank is required for both equalization and treatment since sedimentation is assumed to be accomplished during non-production hours (since the holding time is greater than the time required for treatment). Costs for a chemical precipitant feed system are not included since lime or caustic addition at low application rates can be assumed to be done manually by the operator. A common pump is used for transfer of both the supernatant and sludge through an appropriate valving arrangement.

As in the normal batch case, annual costs consist mainly of labor costs for the low flow system and are based on the following assumptions:

(1) Reaction system

Operating labor is assumed to be constant at 1 hr/
batch (for pH control, sampling, filling, etc.).
For the primary aluminum, secondary aluminum,

primary copper, secondary copper, primary lead, primary zinc, primary tungsten, primary columbium-tantalum, secondary silver, and secondary lead subcategories operating labor value of 2 hrs/batch is used.

Additional labor is also required for the manual addition of lime or caustic, ranging from 15 minutes to 1.5 hrs/batch depending on the feed requirement (1 to 500 lbs/batch).

Maintenance labor is 52 hrs/yr (1 hr/wk).

Energy costs are based on power requirements associated with the agitator and pump.

Chemical costs are based on the use of hydrated lime or liquid caustic (50 percent).

(2) Polymer feed system (batch)

See assumptions for normal batch treatment.

The capital and annual costs for chemical precipitation are presented in Figure VIII-9 (page 358), for all three operating modes.

Sulfide Precipitation and Gravity Settling

Precipitation using sulfide followed by gravity settling is a technology similar to lime precipitation. In general, sulfide precipitation removes more metals from wastewater than lime precipitation because metal sulfides are less soluble than metal hydroxides. Another configuration using sulfide precipitation is appropriate for removal of arsenic and selenium (as well as other metals) in the metallurgical acid plant subcategory. That system is discussed in Section VIII of the metallurgical acid plant subcategory supplement.

Sulfide precipitants can be either soluble sulfides (such as sodium sulfide, or sodium hydrosulfide) or insoluble sulfides (such as ferrous sulfide). Soluble sulfides generate less sludge than insoluble sulfides, are less expensive, and are more commonly used in industry. As such, the sulfide precipitation module is based on the use of sodium sulfide.

The sulfide precipitation system generally used for this category consists of the use of sulfide precipitation as a polishing step following chemical precipitation (described above). Sodium sulfide is added to the wastewater. The sodium sulfide reacts with the remaining dissolved metals to form metal sulfides. The sodium sulfide concentration is calculated as the theoretical stoichiometric requirement based on the influent metals concentration. To calculate chemical requirements, the sodium sulfide dosage is obtained by assuming an excess of 25 percent of the theoretical sodium sulfide dosage. This 25 percent excess of sodium sulfide is needed to ensure complete reaction to the metal sulfides within the time allowed in the reaction tank. As noted below, the sulfide dosage would actually be controlled in a plant by a specific-ion electrode. Effluent concentrations are based

on treatment effectiveness values for sulfide precipitation.

The reaction tank is equipped with a specific-ion electrode which monitors the solution potential during the addition of sodium sulfide. The sulfide ion reacts with the metals in solution to form insoluble metal sulfides as discussed above. When all of the metal is reacted, excess sulfide ion causes a sharp negative potential change, which automatically stops the sulfide addition at the correct point. This control equipment helps to eliminate the release of H₂S gas from the reaction tank. A ventilation hood is included in the cost estimate to control any H₂S which would be released. As a final protection, an aeration system is included to remove any excess sulfide prior to discharge.

As with lime precipitation costs, the costs for sulfide precipitation, and gravity settling are based on one of three operation modes, depending on the influent flow rate: continuous, normal batch, and low flow batch. The use of a particular mode for cost estimation purposes was determined on a least cost (total annualized) basis for a given flow rate. The economic breakpoint between continuous and normal batch is assumed to be 10,600 liters/hour. Below 2,200 liters/hour, it is assumed that the low flow batch system is most economical. Although all three modes of operation were available for cost estimations for the category, the flow rates for all plants requiring sulfide precipitation were in the continuous range of operation. Since only the continuous mode was used, the normal batch and low flow batch operation modes are not included in the following discussion.

For a continuous operation, the following equipment were included in the determination of the capital and annual costs:

(1) Sodium sulfide feed system (continuous)

storage units (sized for 15-day storage)
mix tank (5-minute retention time)
feed pumps
hood for ventilation

(2) Polymer feed system

storage hopper
chemical mix tank with agitator
chemical metering pump

(3) pH adjustment system

rapid mix tank, fiberglass
agitator (velocity gradient is 300 ft/sec/ft)
control system

(4) Sulfide precipitation system

rapid mix tank, fiberglass

agitator (velocity gradient is 300 ft/sec/ft)
hood for ventilation
a specific-ion electrode

(5) Flocculation system

slow mix tank, fiberglass
agitator (velocity gradient is 100 ft/sec/ft)
2.0 mg/l polymer dosage

(6) Gravity settling system

clarifier, circular, steel (overflow rate is 500
gpd/ft², underflow is 3 percent solids)
sludge pump (1)

Lime is added to adjust pH as necessary. Lime costs are included in the subcategory supplements where appropriate. An aeration system (tank and spargers) for removing excess hydrogen sulfide is also included in the costs.

The direct capital costs of the lime, sodium sulfide, and polymer feed systems were based on the respective chemical feed rates (dry lbs/hour), which are dependent on the influent waste stream characteristics. Direct annual costs for the continuous system include operating and maintenance labor for the feed systems and the clarifier, the cost of lime, sodium sulfide, and polymer, maintenance materials and energy costs required to run the agitators and pumps. The assumptions for each of these are similar to those used for lime precipitation. Cost curves are presented in Figure VIII-10 (page 359), page for capital and annual costs of the continuous system. Figure VIII-10 presents cost curves for capital and annual costs that are applicable to the following list of subcategories: primary aluminum, secondary aluminum, primary copper, secondary copper, primary lead, primary zinc, primary tungsten, primary columbium-tantalum, secondary silver, and secondary lead.

Vacuum Filtration

The underflow from the clarifier at 3 percent solids is routed to a rotary precoat vacuum filter, which dewateres sludge to a cake of 20 percent dry solids. The dewatered sludge is disposed of by contract hauling and the filtrate is recycled to the chemical precipitation step.

The capacity of the vacuum filter, expressed as square feet of filtration area, is based on a yield of 14.6 kg of dry solids/hr per square meter of filter area (3 lbs/hr/ft²), a solids capture of 95 percent and an excess capacity of 30 percent. It was assumed that the filter operates eight hours/operating day.

Cost data were compiled for vacuum filters ranging from 0.9 to 69.7 m (9.4 to 750 ft) of filter surface area. Based on a total annualized cost comparison, it was assumed that it was more

economical to directly contract haul clarifier underflow streams which were less than 50 l/hr (0.23 gpm), rather than dewater by vacuum filtration before hauling. For the following list of subcategories, a flow cutoff value of 42 l/hr (0.19 gpm) was used: primary aluminum, secondary aluminum, primary copper, secondary copper, primary lead, primary zinc, primary tungsten, primary columbium-tantalum, secondary silver, and secondary lead.

The costs for the vacuum filtration system include the following equipment:

- (1) Vacuum filter with precoat but no sludge conditioning
- (2) Housing
- (3) Influent transfer pump
- (4) Slurry holding tank
- (5) Sludge pumps

The vacuum filter is sized based on 8 hrs/day operation. The slurry holding tank and pump are excluded when the treatment system operates 8 hrs/day or less. It was assumed in this case that the underflow from the clarifier directly enters the vacuum filter and that holding time volume for the slurry in addition to the clarifier holding time was unnecessary. For cases where the treatment system is operated for more than 8 hrs/day, the underflow is stored during vacuum filter non-operating hours. The filter is sized accordingly to filter the stored slurry in an 8 hour period each day. The holding tank capacity is based on the difference between the plant and vacuum filter operating hours plus an excess capacity of 20 percent. Cost curves for direct capital and annual costs are presented in Figure VIII-11 (page 360), for vacuum filtration. Figure VIII-11 presents cost curves for capital and annual costs that are applicable to the following list of subcategories: primary aluminum, secondary aluminum, primary copper, secondary copper, primary lead, primary zinc, primary tungsten, primary columbium-tantalum, secondary silver, and secondary lead.

The following assumptions were made for developing capital and annual costs:

- (1) Annual costs associated with the vacuum filter were developed based on continuous operation (24 hrs/day! 365 days/yr). These costs were adjusted for a plant's individual operating schedule by assuming that annual costs are proportional to the hours the vacuum filter actually operates. Thus, annual costs were adjusted by the ratio of actual vacuum filter operating hours per year (8 hrs/day x no. days/yr) to the number of hours in continuous operation (8,760 hrs/yr).
- (2) Annual vacuum filter costs include operating and maintenance labor (ranging from 200 to 3,000 hrs/yr as a function of filter size), maintenance materials (generally less than five percent of capital cost), and energy requirements (mainly for the vacuum pumps).

- (3) Enclosure costs for vacuum filtration were based on applying rates of \$45/ft² and \$5/ft /yr for capital and annual costs, respectively to the estimated floor area required by the vacuum filter system. The capital cost rate for enclosure is the standard value as discussed below in the costs for enclosures discussion. The annual cost rate accounts for electrical energy requirements for the filter housing. Floor area for the enclosure is based on equipment dimensions reported in vendor literature, ranging from 300 ft² for the minimum size filter (9.4 ft²) to 1,400 ft² for a vacuum filtration capacity of 1,320 ft².

Holding Tanks-Recycle

A holding tank may be used to recycle water back to a process or for miscellaneous purposes, e.g., storage for hose washdown for plant equipment. Holding tanks are usually implemented when the recycled water need not be cooled. The equipment used to determine capital costs are a fiberglass tank, pump, and recycle piping. Annual costs are associated only with the pump. The capital cost of a fiberglass tank is estimated on the basis of required tank volume. Required tank volume is calculated on the basis of influent flow rate, 20 percent excess capacity, and four hour retention time. The influent flow and the degree of recycle were derived from the assumptions outlined in Table VIII-9.

Cost curves for direct capital and annual costs are presented in Figure VIII-12 (page 361).

Multimedia Filtration

Multimedia filtration is used as a wastewater treatment polishing device to remove suspended solids not removed in previous treatment processes. The filter beds consist of graded layers of coarse anthracite coal and fine sand. The equipment used to determine capital and annual costs are as follows:

- (1) Gravity flow, vertical steel cylindrical filters with media (anthracite and sand)
- (2) Influent storage tank sized for one backwash volume
- (3) Backwash tank sized for one backwash volume
- (4) Backwash pump to provide necessary flow and head for backwash operations including an air scour system
- (5) Influent transfer pump including piping, valves, and a control system

The hydraulic loading rate is 7,335 lph/m² (180 gph/ft²) and the backwash loading rate is 29,340 lph/m² (720 gph/ft²). The filter is backwashed once per 24 hours for 10 minutes. The backwash volume is provided from the stored filtrate.

Effluent pollutant concentrations are based on the Agency's combined metals data base for treatability of pollutants by

filtration technology.

Cartridge-type filters are used instead of multimedia filters to treat small flows (less than 800 liters/hour) since they are more economical than multimedia filters at these flows (based on a least total annualized cost comparison). The effluent quality achieved by these filters was equivalent to the level attained by multimedia filters. The equipment used to determine capital and annual costs for membrane filtration are as follows:

- (1) influent holding tank sized for eight hours retention
- (2) pump
- (3) prefilter
 - prefilter cartridges
 - prefilter housings
- (g) membrane filter
 - membrane filter cartridges
 - housing

The majority of annual cost is attributable to replacement of the spent prefilter and membrane filter cartridges. The maximum loading for the prefilter and membrane filter cartridges was assumed to be 0.225 kg per 0.254 meter length of cartridge. The annual energy and maintenance costs associated with the pump are also included in the total annual costs. Cost curves for direct capital and annual costs are presented in Figure VIII-13 (page 362) for cartridge and multimedia filtration.

Activated Carbon Adsorption

Activated carbon is used to remove dissolved organic contaminants from wastewater. As the wastewater is pumped through the carbon column, organic contaminants diffuse into the carbon particles through pores and are adsorbed onto the pore walls. As organic material accumulates, the carbon loses its effectiveness and must be replaced or regenerated periodically.

Two downflow carbon columns in series are used. The leading column loses its effectiveness first, since most of the organics are adsorbed in it. When breakthrough occurs (i.e., when the column effluent concentration of a specified organic exceeds a specified maximum), the column is taken off-line and the second column becomes the leading column. When the carbon in the first column is regenerated or replaced, it becomes the following column. This configuration, known as a merry-go-round, results in a more consistent effluent quality than a single, larger column or a system where one column is active and one on standby. During column operation, solids accumulate in the interstices of the carbon bed. To prevent the column from plugging, the bed must be periodically backwashed to remove these solids. Also, a method for replacing spent carbon is required. Either replacement with virgin carbon and disposal of the spent carbon

or regeneration of the spent carbon via off-site or on-site regeneration may be used.

The following pieces of equipment were included in the determination of capital and annual costs:

(1) Carbon adsorption system

adsorption columns (2), downflow, merry-go-round configuration
--hydraulic loading of 2.5 gpm/ft^2
initial carbon charge
pump

(2) Backwash facilities

backwash hold tank - to provide 15 gpm/ft^2 per column for 15 min.
pump

(3) Influent surge tank (1-hour retention time)

(4) Carbon replacement/regeneration facilities

replacement
off-site regeneration
on-site regeneration

The direct capital costs for the adsorption system pump, backwash facilities, and surge tank are direct or indirect functions of the influent flow rate. Direct capital costs for the adsorption columns and replacement or regeneration facilities are functions of the influent flow rate and the rate at which carbon is used, or the carbon exhaustion rate. The rate (expressed in kg/l or lbs/ 1,000 gal) used depended upon the data available for the types of organic contaminants being adsorbed. Carbon adsorption data for a specific type of wastewater were preferred when available; otherwise, isotherm data for selected organics were used with conservative design factors. The specific exhaustion rates selected are provided in the subcategory supplements.

The direct annual costs for the adsorption columns, backwash facilities, and surge tank included operation and maintenance labor for the columns and backwash facilities, maintenance materials, and energy costs for pumping.

The carbon usage rate (kg carbon exhausted/hr) is a function of the influent flow rate combined with the carbon exhaustion rate expressed as a carbon usage rate (lbs carbon exhausted/hr). One of three operating regimes is chosen on a least cost (total annualized) basis for a given carbon usage rate. Below a usage rate of about 1.6 lbs/hr, replacement of spent carbon with virgin carbon and disposal of the spent carbon as a hazardous waste was found to be most economical. Between 1.6 and 53 lbs/hr, regeneration by an off-site regeneration service is more cost

effective. On-site regeneration facilities are more economical above 53 lbs/hr.

For the carbon replacement option, no additional capital investment is required. Direct annual costs consist of contract hauling the spent carbon as a hazardous waste and the purchase and installation of virgin carbon.

Direct capital costs for the off-site regeneration option include hoppers for dewatering and storage of spent carbon. Also included is the cost of acquiring an increased carbon inventory where the actual required inventory is less than the minimum for economical off-site regeneration (about 20,000 lbs). Direct annual costs include the charge for regeneration, transportation of the carbon to and from the regeneration facility, and costs for placing carbon into the column.

Direct capital costs for an on-site regeneration facility include costs for a multiple hearth furnace and associated equipment, spent carbon storage, exhaust gas scrubbers, a carbon slurry system, quench tank, housing, and controls and instrumentation. Direct annual costs include operation and maintenance labor for the regeneration facility, maintenance materials, and electricity and natural gas costs for the building, electrical equipment, and furnace. Also included is the cost of replacing carbon lost in the regeneration process (10 percent of the spent carbon passing through the furnace) with virgin carbon.

The total direct capital and annual costs for the activated carbon adsorption system are presented in Figure VIII-14 (page 363). Figure VIII-14 presents cost curves for capital and annual costs that are applicable to the following list of subcategories: primary aluminum, secondary aluminum, primary copper, secondary copper, primary lead, primary zinc, primary tungsten, primary columbium-tantalum, secondary silver, and secondary lead.

Chemical Oxidation

Chemical oxidation using ozone is an alternative technology to activated carbon adsorption in the bauxite refining subcategory for removing dissolved organics from the red mud impoundment net precipitation discharges. Compliance costs for the bauxite subcategory were based on activated carbon adsorption since it was more cost-effective than chemical oxidation based on a total annualized cost comparison. Chemical oxidation with ozone proved to be uneconomical due to the capital intensive ozone generation equipment required for the relatively high ozone consumption rates encountered.

Ozone and hydrogen peroxide are considered as chemical oxidants because they do not result in the release of secondary pollutants, such as manganese or residual chlorine. Given the high pH of the red mud impoundment net precipitation discharge (11.5), ozone was selected over hydrogen peroxide because the peroxide reaction occurs optimally at a pH of 4 or less, whereas

ozone only requires neutralization to a pH of 7. An ozone dosage level of 50 mg/l was assumed for the particular organics and COD loadings found in the red mud impoundment waste stream. Neutralization of the waste stream to a pH of 7 with lime prior to contact with ozone was accounted for in developing costs.

The costs for chemical oxidation with ozone were based on the following equipment:

- (1) Ozone generator
 - ozone preparation and dissolution equipment
 - electrical and instrumentation
 - safety and monitoring equipment
- (2) Contact chamber, concrete (90 minute contact time)
- (3) Neutralization system
 - mixing tank
 - pump
 - agitator

Annual costs comprise mainly the labor and electricity costs required to operate the ozone generation equipment and operation and maintenance cost of the neutralization system.

Contract Hauling

Concentrated sludge and waste oils are removed on a contract basis for off-site disposal. The cost of contract hauling depends on the classification of the waste as being either hazardous or nonhazardous. For nonhazardous wastes, a rate of \$0.106/liter (\$0.40/gallon) was used in determining contract hauling costs. The cost for contract hauling hazardous wastes was developed from a survey of waste disposal services and varies with the amount of waste hauled. No capital costs are associated with contract hauling. Annual cost curves for contract hauling nonhazardous and hazardous wastes are presented in Figure VIII-15 (page 364).

Enclosures

The costs of enclosures for equipment considered to require protection from inclement weather were accounted for separately from the module costs (except for vacuum filtration). In particular, chemical feed systems were generally assumed to require enclosure.

Costs for enclosures were obtained by first estimating the required enclosure area and then multiplying this value by the unit cost in dollars per unit area. A capital cost of \$485/m² (\$45/ft²) was estimated, based on the following:

- structure (including roofing, materials, insulation, etc.)
- site work (masonry, installation, etc.)

-- electrical and plumbing

The rate for annual costs of enclosures is \$54/m² (\$5/ft²) which accounts for energy requirements for heating and lighting the enclosure.

The required enclosure area is determined as the amount to total required enclosure area which exceeds the enclosure area estimated to be available at a particular plant. It was assumed that a common structure could be used to enclose all equipment needing housing unless information was available to indicate that separate enclosures are needed (e.g., due to plant layout). The individual areas are estimated from equipment dimensions reported by vendors and appropriate excess factors. The available enclosure areas were assumed as a function of plant site, based on experience from site visits at numerous plants.

Segregation

Costs for segregation of wastewaters not included in this regulation (e.g., noncontact cooling water) or for routing regulated waste streams not currently treated to the treatment system were included in the compliance cost estimates. The capital costs for segregating the above streams were determined using a rate of \$6,900 for each stream requiring segregation. This rate is based on the purchase and installation of 50 feet of 10 cm (4-inch) piping (with valves, pipe racks, and elbows) for each stream. Annual costs associated with segregation are assumed to be negligible.

Where a common stormwater-process wastewater piping system was used at a plant, costs were included for both segregation of each process waste stream to treatment (based on the above rate) and segregation of stormwater for rerouting around the treatment system.

Stormwater segregation cost is \$8,800 based on the underground installation of 305 m (300 feet) of 0.61 m (24-inch) diameter concrete pipe.

COMPLIANCE COST ESTIMATION

To calculate the compliance cost estimates, the model was run using input data as described previously. A cost summary is prepared for each plant. An example of this summary may be found in Table VIII-10 (page 347). Referring to this table, four types of data are included for each option: run number, total capital costs, required capital costs, and annual costs. Run number refers to the computer run from which the costs were derived.

Total capital costs include the capital cost estimate for each piece of wastewater treatment equipment necessary to meet mass limitations. Required capital costs are determined by considering the equipment and wastewater treatment system a plant currently has in place. As discussed previously, the required

capital costs reflect the estimates of the actual capital cost the facility will incur to purchase and install the necessary treatment equipment by accounting for what that facility already has installed. Adequate operation and size of equipment currently at a facility must be demonstrated before equipment is considered to be in place. This prevents compliance cost underestimation. Annual costs are based on all equipment in the treatment system, as discussed previously.

NONWATER QUALITY ASPECTS

The elimination or reduction of one form of pollution may aggravate other environmental problems. Therefore, Sections 304(b) and 306 of the Act require EPA to consider the nonwater quality environmental impacts (including energy requirements) of certain regulations. In compliance with these provisions, EPA has considered the effect of this regulation on air pollution, solid waste generation, water scarcity, and energy consumption. This regulation was circulated to and reviewed by EPA personnel responsible for nonwater quality environmental programs. While it is difficult to balance pollution problems against each other and against energy utilization, the Administrator has determined that the impacts identified below are justified by the benefits associated with compliance with the limitations and standards. The following are the nonwater quality environmental impacts associated with compliance with BPT, BAT, NSPS, PSES, and PSNS.

Air Pollution, Radiation, and Noise

In general, none of the wastewater treatment or control processes causes air pollution. Steam stripping of ammonia has a potential to generate atmospheric emissions, however, with proper design and operation, air pollution impacts are prevented. Air stripping to ammonia also has a potential to generate atmospheric emissions, because air stripping transfers ammonia from a water to an air medium. Because air stripping was only considered as a technology option for plants which presently use air stripping, the Agency does not believe it will create an air quality problem. Sulfide precipitation operations can involve hydrogen sulfide vapors if not properly controlled. EPA's design for sulfide precipitation includes an automatic pH-controller equipped with a specific-ion electrode that monitors solution potential during sulfide addition. When all to the available metal ions are sequestered by the sulfide, the excess sulfide ion causes a sharp negative potential change, automatically stopping the sulfide addition. None of the wastewater treatment processes cause objectionable noise or have any potential for radiation hazards.

Solid Waste Disposal

As shown in the subcategory supplements, the waste streams being discharged contain large quantities of toxic and other metals: the most common method to removing the metals is by chemical precipitation. Consequently, significant volumes of heavy

metal laden sludge are generated that must be disposed of properly.

The technologies that directly generate sludge are:

1. Cyanide precipitation
2. Chemical precipitation (lime, caustic, sulfide, iron co-precipitation, etc.)
3. Multimedia filtration
4. Oil-water separation

Spent carbon from activated carbon adsorption also represents a solid waste stream requiring disposal. The sludge volumes generated by plants complying with these effluent limitations and standards are estimated for each subcategory in Table VIII-12 (page 348).

The estimated sludge volumes generated from wastewater treatment were obtained from material balances performed by the computer model during cost estimation. The sludges resulting from the technologies listed above will vary in characteristics depending on the subcategory and combination of streams being treated. The majority of sludge produced will be either dewatered sludge from filtration or sludge from chemical precipitation.

A major concern in the disposal of sludges is the contamination of soils, plants, and animals by the heavy metals contained in the sludge. The leaching of heavy metals from sludge and subsequent movement through soils is enhanced by acidic conditions. Sludges formed by chemical precipitation possess high pH values and thus are more resistant to acid leaching. Since the largest amount of sludge that results from the alternatives is generated by chemical precipitation, it is not expected that metals will be readily leached from the sludge. Disposal of sludges in a lined sanitary landfill will further reduce the possibility of heavy metals contamination of soil, plants, and animals.

Other methods of treating and disposing sludge are available. One method currently being used at a number of plants is reuse or recycle, usually to recover metals. Since the metal concentrations in some sludges may be substantial, it may be cost effective for some plants to recover the metal fraction of their sludges prior to disposal.

The Solid Waste Disposal Act Amendments of 1980 prohibited EPA from regulating certain wastes under Subtitle C of RCRA until completion of certain studies and certain rulemaking. Among these wastes are "solid waste from the extraction, beneficiation and processing of ores and minerals." EPA has therefore exempted from hazardous waste status any solid wastes from primary smelting and refining, as well as from exploration, mining, and

milling.

The Agency has not made a determination of the hazardous character of sludges and solid wastes generated from the secondary metals processing plants covered by this regulation. Each sludge generator in the secondary metals subcategories is subject to the RCRA tests for ignitability, corrosivity, reactivity, and toxicity. Costs for treatment and disposal of such sludges and solid wastes, as well as nonhazardous sludges and solid wastes, have been presented in this section.

Wastewater treatment sludges from this category are expected to be non-hazardous by the E.P. Toxicity test under RCRA when generated using the model technology. The only sludges expected to be hazardous under RCRA, generated as a result of wastewater treatment, are those from sulfide or cyanide precipitation steps. The Agency has included costs for disposal of those hazardous sludges in its estimates of compliance costs. Treatment of similar wastewaters from other categories using this technology has resulted in non-hazardous sludges. Costs for disposal of non-hazardous wastes are included in the annual costs.

Consumptive Water Loss

Treatment and control technologies that require extensive recycling and reuse of water may require cooling mechanisms. Evaporative cooling mechanisms can cause water loss and contribute to water scarcity problems, a primary concern in arid and semi-arid regions. While this regulation assumes water reuse, the overall amount of reuse through evaporative cooling mechanisms is low and the quantity of water involved is not significant. The Agency has concluded that consumptive water loss is insignificant and that the pollution reduction benefits of recycle technologies outweigh their impact on consumptive water loss.

Energy Requirements

The incremental energy requirements of a wastewater treatment system have been determined in order to consider the impact of this regulation on natural resource depletion and on various national economic factors associated with energy consumption. The calculation of energy requirements for wastewater treatment facilities proceeded in two steps. First, the portion of operating costs which were attributable to energy requirements was estimated for each wastewater treatment module. Then, these fractions, or energy factors, were applied to each module in all plants to obtain the energy costs associated with wastewater treatment for each plant. These costs were summed for each subcategory and converted to kW-hrs using the electricity charge rate previously mentioned (\$0.0483/kW-hr for March 1982). The total plant energy usage was calculated based on the data collection portfolios.

Table VIII-12 (page 349), presents these energy requirements for

each regulatory option on each subcategory. From the data in this table, the Agency has concluded that the energy requirements of the proposed treatment options will not significantly affect the natural resource base nor energy distribution or consumption in communities where plants are located.

Table VIII-1

BPT COSTS OF COMPLIANCE FOR THE
NONFERROUS METALS MANUFACTURING CATEGORY

<u>Subcategory</u>	Final Regulation Cost Estimates (\$1982)	
	<u>Capital</u>	<u>Annual</u>
Primary Lead	242,000	112,000
Primary Tungsten	619,000	1,008,000
Primary Columbium-Tantalum	680,000	1,139,000
Secondary Silver	110,000	309,000
Secondary Lead	1,631,000	1,124,000
Primary Antimony	196,400	554,200
Primary Beryllium	226,500	211,200
Primary and Secondary Germanium and Gallium	B	B
Primary Molybdenum and Rhenium	B	B
Metallurgical Acid Plants (associated with molybdenum roasters)	B	B
Secondary Molybdenum and Vanadium	B	B
Primary Nickel and Cobalt	B	B
Primary Precious Metals and Mercury	2,200	26,800
Secondary Precious Metals	B	B
Primary Rare Earth Metals	A	28,700
Secondary Tantalum	B	B
Secondary Tin	841,300	692,600
Primary and Secondary Titanium	644,500	505,300
Secondary Tungsten and Cobalt	B	B
Secondary Uranium	54,800	90,400
Primary Zirconium and Hafnium	B	B

NOTES: A = no incremental costs
B = based on confidential data

*Costs are shown for the selected option only.

Table VIII-2

BAT COSTS OF COMPLIANCE FOR THE
NONFERROUS METALS MANUFACTURING CATEGORY

<u>Subcategory</u>	<u>Number of Dischargers</u>	<u>Promulgated Regulation Cost Estimates (\$1982)*</u>	
		<u>Capital</u>	<u>Annual</u>
Primary Lead		242,000	112,000
Primary Tungsten		619,000	1,008,000
Primary Columbium-Tantalum		680,000	1,139,000
Secondary Silver		110,000	309,000
Secondary Lead		1,631,000	1,124,000
Primary Antimony	1	196,400	554,200
Bauxite Refining	3	A	B
Primary Beryllium	1	226,500	211,200
Primary and Secondary Germanium and Gallium	0	B	B
Primary Molybdenum and Rhenium	2	B	B
Metallurgical Acid Plants (associated with molybdenum roasters)	2	B	B
Secondary Molybdenum and Vanadium	1	B	B
Primary Nickel and Cobalt	1	B	B
Primary Precious Metals and Mercury	1	3,025	27,300
Secondary Precious Metals	4	B	B
Primary Rare Earth Metals	1	B	B
Secondary Tantalum	3	B	B
Secondary Tin	3	B	B
Primary and Secondary Titanium	4	1,030,000	585,000
Secondary Tungsten and Cobalt	4	B	B
Secondary Uranium	1	88,000	106,700
Primary Zirconium and Hafnium	1	B	B

NOTES: A = no incremental costs

B = based on confidential data

*Costs are shown for the selected option only.

Table VIII-3

PSES COSTS OF COMPLIANCE FOR THE
NONFERROUS METALS MANUFACTURING CATEGORY

<u>Subcategory</u>	<u>Number of Indirect Dischargers</u>	<u>Promulgated Regulation Cost Estimates (\$1982)*</u>	
		<u>Capital</u>	<u>Annual</u>
Primary and Secondary Germanium and Gallium	1	B	B
Secondary Indium	1	17,300	25,400
Secondary Nickel	1	320,000	161,200
Secondary Precious Metals	30	1,734,300	1,059,400
Primary Rare Earth Metals	1	B	B
Secondary Tin	2	160,200	50,000
Primary and Secondary Titanium	2	B	B
Secondary Tungsten and Cobalt	1	16,300	8,800

NOTES: B = based on confidential information

*Costs are shown for the selected option only.

Table VIII-4

NONFERROUS METALS MANUFACTURING PHASE II CATEGORY
COST EQUATIONS FOR RECOMMENDED TREATMENT
AND CONTROL TECHNOLOGIES

<u>Equipment</u>	<u>Equation</u>	<u>Range of Validity</u>
Aerator for Sulfide Precipitation	$C = 207.046 + 0.974477 (X)$ $- 1.58743 \times 10^{-5} (X)^2$ $A = -1.536 + 0.504294 (X)$ $- 8.15566 \times 10^{-7} (X)^2$	$100 < X < 25,000$
330 Agitator, C-clamp	$C = 839.1 + 587.5 (HP)$ $A = 0.0483 \times 0.746 (HP) + 0.05 (C)$	$0.25 < HP < 0.33$
Agitator, Top Entry	$C = 1,585.55 + 125.302 (HP) - 3.27437 (HP)^2$ $A = 0.0483 \times 0.746 (HP) + 0.05 (C)$	$0.33 < HP < 5.0$
Clarifier, Concrete	$C = 78,400 + 32.65 (S) - 7.5357 \times 10^{-4} (S)^2$ $A = \exp[8.22809 - 0.224781 (\ln S)$ $+ 0.0563252 (\ln S)^2]$	$500 < S < 12,000$
Clarifier Steel	$C = 41,197.1 + 72.0979(S) + 0.0106542(S)^2$ $A = \exp[8.22809 - 0.224781 (\ln S)$ $+ 0.0563252 (\ln S)^2]$	$300 < S < 2,800$

Table VIII-4 (Continued)

NONFERROUS METALS MANUFACTURING PHASE II CATEGORY
 COST EQUATIONS FOR RECOMMENDED TREATMENT
 AND CONTROL TECHNOLOGIES

<u>Equipment</u>	<u>Equation</u>	<u>Range of Validity</u>	
Cooling Tower System	$C = \exp[8.76408 + 0.07048 (\ln CTON) + 0.05095 (\ln CTON)^2]$	$5 < CTON < 700$	
	$A = \exp[9.08702 + 0.75544 (\ln CTON) + 0.140379 (\ln CTON)^2]$	$5 < CTON < 700$	
Contract Hauling	$C = 0$	Non Hazardous	
	$A = 0.40 (G)(HPY)$		
Equalization Basin	$C = 0$	Hazardous	
	$A = \exp[-0.0240857 + 1.02731 (\ln G) - 0.0196787 (\ln G)^2](HPY)$		
	$C = 14,759.8 + 0.170817 (V) - 8.44271 \times 10^{-8} (V)^2$		$24,000 < V < 500,000$
	$C = 3,100.44 + 1.19041 (V) - 1.7288 \times 10^{-5} (V)^2$		$1,000 < V < 24,000$
	$C = \exp[4.73808 - 0.0628537 (\ln V) + 0.0754345 (\ln V)^2]$	$V < 1,000$	
	$A = 0.05 (C)$	$0 < V < 500,000$	

Table VIII-4 (Continued)

NONFERROUS METALS MANUFACTURING PHASE II CATEGORY
COST EQUATIONS FOR RECOMMENDED TREATMENT
AND CONTROL TECHNOLOGIES

<u>Equipment</u>	<u>Equation</u>	<u>Range of Validity</u>
Equalization Basin	$C = 14,759.8 + 0.170817 (V) - 8.44271$ $\times 10^{-8} (V)^2$	$24,000 < V < 500,000$
	$C = 3,100.44 + 1.19041 (V) - 1.7288$ $\times 10^{-5} (V)^2$	$1,000 < V < 24,000$
	$C = \exp[4.73808 - 0.0628537(\ln V)$ $+ 0.0754345 (\ln V)^2]$	$V < 1,000$
	$A = 0.05 (C)$	$0 < V < 500,000$
Feed System, Caustic	Continuous feed:	
	$C = \exp[9.63461 + 8.36122 \times 10^{-3} (\ln F)$ $+ 0.0241809 (\ln F)^2]$	$0.4 < F < 417$
	$A = \exp[7.9707 - 4.45846 \times 10^{-3} (\ln F)$ $+ 0.0225972 (\ln F)^2] + 0.183 (HPY)(F)$	
	Batch feed:	
	$C = \exp[7.50026 + 0.199364 (\ln F)$ $+ 0.0416602 (\ln F)^2]$	$1.5 < F < 1,500$
	$A = (21)[16 + 0.5 (BPY)] + 0.131 (F)(HPY)$	

Table VIII-4 (Continued)

NONFERROUS METALS MANUFACTURING PHASE II CATEGORY
COST EQUATIONS FOR RECOMMENDED TREATMENT
AND CONTROL TECHNOLOGIES

<u>Equipment</u>	<u>Equation</u>	<u>Range of Validity</u>
	Low flow batch feed:	
	C = 250	X < 100
	A = 10.5 (BPY) + 0.131 (F) (HPY)	
Feed System, Defoamer	C = 980	0 < X < 83,000
	A = 6.5 x 10 ⁻⁵ (X) (HPY)	
Feed System, Lime (Manual)	C = 0	
	A = (DPY)[0.074 (B) + 5.25 (NB)]	X < 2,000
Feed System, Lime (Batch)	C = 1,697.79 + 19.489 (B) - 0.036824 (B) ²	1 < B < 200
	C = 16,149.2 + 10.2512 (B) - 1.65864 x 10 ⁻³ (B) ²	B > 200
	A = (BPY)[5.01989 + 0.0551812 (B) - 1.79331 x 10 ⁻⁵ (B) ²] + 545	
Feed System, Lime (Continuous)	C = exp[6.32249 + 1.70246 (lnF) - 0.137186 (lnF) ²]	10 < F < 1,000
	A = exp[4.87322 + 1.78557 (lnF) + 0.136732 (lnF) ²] + (F)(HPY)(LC)	

Table VIII-4 (Continued)

NONFERROUS METALS MANUFACTURING PHASE II CATEGORY
 COST EQUATIONS FOR RECOMMENDED TREATMENT
 AND CONTROL TECHNOLOGIES

<u>Equipment</u>	<u>Equation</u>	<u>Range of Validity</u>
Feed System, Ferrous Sulfate	$C = \exp[10.1703 - 0.38694 (\ln F) + 0.0765919 (\ln F)^2]$ $A = \exp[9.696551 - 0.612972 (\ln F) + 0.0960144 (\ln F)^2] + 0.0575 (F) (\text{HPY})$	$10.7 < F < 5350$
Feed System, Polymer	$C = \exp[9.83111 + 0.663271 (\ln F) + 0.0557039 (\ln F)^2]$ $A = 0.42 (F)(\text{HPY}) + 1050$ $C = 13,150 + 2515.2 (F)$ $A = \exp[8.60954 + 0.04109 (\ln F) + 0.0109397 (\ln F)^2] + 2.25 (F)(\text{HPY})$	$0.04 < F < 0.5$ $0.5 < F < 12$
Feed System, Sodium Sulfide (Manual)	$C = 0$ $A = [0.240 (B) + 5.25 (NB)](\text{DPY})$	$X < 2200$
Feed System, Sodium Sulfide (Continuous)	$C = 13,953.3 + 117.18 (F) - 0.069117 (F)^2$ $A = [0.758002 + 0.140318 (F) - 8.6493 \times 10^{-8} (F)^2](\text{HPY})$	$10 < F < 5,350$

Table VIII-4 (Continued)

NONFERROUS METALS MANUFACTURING PHASE II CATEGORY
 COST EQUATIONS FOR RECOMMENDED TREATMENT
 AND CONTROL TECHNOLOGIES

<u>Equipment</u>	<u>Equation</u>	<u>Range of Validity</u>
Feed System, Sulfuric Acid	$C = \exp[8.1441 + 0.23345 (\ln F) + 0.0180092 (\ln F)^2]$ $A = \exp[7.36913 + 0.0133111 (\ln F) + 0.029219 (\ln F)^2] + 0.03743 (F)(HPY)$	$0.01 < F < 3,200$
Filter, Multimedia	$C = 10,888 + 277.85 (SA) - 0.154337 (SA)^2$ $A = \exp[8.20771 + 0.275272 (\ln SA) + 0.0323124 (\ln SA)^2]$	$7 < SA < 500$
Filter, Membrane	$C = 290.48 + 31.441 (Y) - 0.050717 (Y)^2$ $A = [8.34253 \times 10^{-3} + 0.173683 (SR) - 4.1435 \times 10^{-5} (SR)^2](HPY)$	$2 < Y < 140$
	$C = -2,922.48 + 60.6411 (Y) - 0.065206 (Y)^2$ $A = [-0.0152849 + 0.172153 (SR) - 3.46041 \times 10^{-6} (SR)^2](HPY)$	$140 < Y < 336$
Granular Activated Carbon	$C = 1.739 (CINT)(0.93662)$ $A = 1.739 (CLOS)(0.93662)$	$0 < CINT < 107$ $0 < CLOS < 107$

Table VIII-4 (Continued)

NONFERROUS METALS MANUFACTURING PHASE II CATEGORY
COST EQUATIONS FOR RECOMMENDED TREATMENT
AND CONTROL TECHNOLOGIES

<u>Equipment</u>	<u>Equation</u>	<u>Range of Validity</u>
Granular Activated Carbon Columns	$C = \exp[9.649881 + 0.645947 (\ln DF) + 0.0572931 (\ln DF)^2]$ $A = \exp[7.37615 + 0.570095 (\ln DF) + 0.196441 (\ln DF)^2]$	$2 < DF < 9$
Granular Activated Carbon, Off-site Regeneration	$C = \exp[7.602986 + 0.900958 (\ln CB) - 9.70893 \times 10^{-3} (\ln CB)^2]$ $A = 1.84214 + 4516.24 (LBC) + 3.66964 \times 10^{-3} (LBC)^2$	$26.5 < CB < 530$ $3.4 < LBC < 342$
Granular Activated Carbon, On-site Regeneration	$C = \exp[11.797 + 0.317114 (\ln LBC) + 8.85061 \times 10^{-3} (\ln LBC)^2]$ $A = \exp[8.84373 + 0.490475 (\ln LBC) + 0.0252024 (\ln LBC)^2] (HPB)$	$56 < LBC < 3138$
Oil/Water Separator, Coalescent type	$C = 5,542.07 + 65.7158 (Y) - 0.029627 (Y)^2$ $A = 783.04 + 6.3616 (Y) - 0.001736 (Y)^2$	$0 < Y < 700$

Table VIII-4 (Continued)

NONFERROUS METALS MANUFACTURING PHASE II CATEGORY
COST EQUATIONS FOR RECOMMENDED TREATMENT
AND CONTROL TECHNOLOGIES

<u>Equipment</u>	<u>Equation</u>	<u>Range of Validity</u>
Oil/Water Separator, Belt-type (Small Flow)	C = 2370 A = 1300 C = 2900 A = 1500	OC < 25 OC > 25
Piping, Recycle	C = $\exp[6.55278 + 0.382166 (\ln D)$ $+ 0.133144 (\ln D)^2] (0.01)(L)$ A = 0	D > 1
Prefilter, Cartridge	C = $283.353 + 25.9111 (Y) - 0.058203 (Y)^2$ A = $[0.118985 + 0.0803004 (SR) - 1.66003$ $\times 10^{-5} (SR)^2](HPY)$	2 < Y < 140
	C = $-2,612.73 + 51.568 (Y) - 0.059361 (Y)^2$ A = $[-3.82339 + 0.0937196 (SR) - 1.7736$ $\times 10^{-5} (SR)^2](HPY)$	140 < Y < 336
Pump, Centrifugal	C = $\exp[6.31076 + 0.228887(\ln Y)$ $+ 0.0206172 (\ln Y)^2]$ A = $\exp[6.67588 + 0.031335 (\ln Y)$ $+ 0.062016 (\ln Y)^2] (HPB)$	3 < Y < 3,500

Table VIII-4 (Continued)

NONFERROUS METALS MANUFACTURING PHASE II CATEGORY
COST EQUATIONS FOR RECOMMENDED TREATMENT
AND CONTROL TECHNOLOGIES

<u>Equipment</u>	<u>Equation</u>	<u>Range of Validity</u>
Pump, Sludge	$C = 2,264.31 + 21.0097 (Y) - 0.0037265 (Y)^2$ $A = \exp[7.64414 + 0.192172 (\ln Y) + 0.0202428 (\ln Y)^2] \text{ (HPB)}$	$5 < Y < 500$
Tank, Batch Reactor	$C = \exp[4.73808 - 0.0628537 (\ln V) + 0.0754345 (\ln V)^2]$ $C = 3,100.44 + 1.19041 (V) - 1.7288 \times 10^{-5} (V)^2$ $A = 1,090 + 21 \text{ (BPY)}$ $A = \exp[8.65018 - 0.0558684 (\ln X) + 0.0145276 (\ln X)^2]$	$57 < V < 1,000$ $1,000 < V < 24,000$ $X < 2,200$ $2,200 < X < 11,600$
Tank, Concrete	$C = 5,800 + 0.8V$ $A = 0.02 \text{ (C)}$	$24,000 < V < 500,000$
Tank, Large Fiberglass	$C = 3,100.44 + 1.19041 (V) - 1.7288 \times 10^{-5} (V)^2$ $A = 0.02 \text{ (C)}$	$1,000 < V < 24,000$
Tank, Small	$C = \exp[4.7308 - 0.0628537 (\ln V) + 0.0754345 (\ln V)^2]$ $A = 0.02 \text{ (C)}$	$57 < V < 1,000$

Table VIII-4 (Continued)

NONFERROUS METALS MANUFACTURING PHASE II CATEGORY
COST EQUATIONS FOR RECOMMENDED TREATMENT
AND CONTROL TECHNOLOGIES

<u>Equipment</u>	<u>Equation</u>	<u>Range of Validity</u>
Tank, Large Steel	$C = 3,128.83 + 2.37281 (V) - 7.10689$ $\quad \times 10^{-5}(V)^2$	$500 < V < 12,000$
	$C = 14,759.8 + 0.170817 (V)$ $\quad - 8.44271 \times 10^{-8} (V)^2$	$V > 25,000$
	$A = 0.02 (C)$	
Tank, Small Steel	$C = 692.824 + 6.16706 (V) - 3.95367$ $\quad \times 10^{-3}(V)^2$	$100 < V < 500$
	$A = 0.02 (C)$	
Vacuum Filter	$C = 71,083.7 + 442.3 (SA) - 0.233807 (SA)^2$ $A = 17,471.4 + 677.408 (SA) - 0.484647 (SA)^2$	$9.4 < SA < 750$
Vacuum Filter Housing	$C = (45)[308.253 + 0.836592 (SA)]$ $A = (4.96)[308.253 + 0.836592 (SA)]$	$9.4 < SA < 750$

Table VIII-4 (Continued)

NONFERROUS METALS MANUFACTURING PHASE II CATEGORY
 COST EQUATIONS FOR RECOMMENDED TREATMENT
 AND CONTROL TECHNOLOGIES

VARIABLE DEFINITIONS

- A = Direct annual costs (1982 dollars/year)
- B = Batch chemical feed rate (pounds/batch)
- BD = Batch chemical feed rate (pounds/day)
- BPY = Number of batches per year
- C = Direct capital, or equipment costs (1982 dollars)
- CB = Activated carbon inventory (10^3 lb)
- CINT = Initial carbon charge (lb)
- CLOS = Carbon replacement requirement (lb)
- CTON = Evaporative tons
- D = Inner diameter of pipe (inches)
- DF = Inner diameter of column (feet)
- DPY = Days of operation per year
- F = Chemical feed rate (pounds/hour)
- G = Sludge disposal rate (gallons/hour)
- HP = Power requirement (horsepower)
- HPB = Fraction of time equipment is in operation
- HPY = Plant operating hours (hours/year)
- L = Length of piping (feet)
- LBC = Activated carbon regeneration rate (lb/hr)
- LC = Lime cost (\$/lb, March 1982)
- NB = Number of batches per day
- OC = Oil removed (gallons/day)
- S = Clarifier surface area (square feet)
- SA = Filter surface area (square feet)
- SR = Solids removed by filter (grams/hour)
- V = Tank capacity (gallons)
- X = Wastewater flow rate (liters/hour)
- Y = Wastewater flow rate (gallons/minute)

Table VIII-5

COMPONENTS OF TOTAL CAPITAL INVESTMENT

<u>Item Number</u>	<u>Item</u>	<u>Cost</u>
1	Bare Module Capital Costs	Direct capital costs from model ^a
2	Electrical & instrumentation	0% of item 1
3	Yard piping	0% of item 2
4	Enclosure	Included in item 1
5	Pumping	Included in item 1
6	Retrofit allowance	Included in item 1
7	Total Module Cost	Item 1 + items 2 through 6
8	Engineering/admin. & legal	10.0% of item 7
9	Construction/yardwork	0% of item 7
10	Monitoring	0% of item 7
11	Total Plant Cost	Item 7 + items 8 through 10
12	Contingency	15% of item 11
13	Contractor's fee	10% of item 11
14	Total Construction Cost	Item 11 + items 12 through 13
15	Interest during construction	0% of item 14
16	Total Depreciable Investment	Item 14 + item 15
17	Land	0% of item 16
18	Working capital	0% of item 16
19	Total Capital Investment	Item 16 + items 17 through 18

^aDirect capital costs include costs of equipment and required accessories, installation, and delivery.

Table VIII-6
COMPONENTS OF TOTAL ANNUALIZED COSTS

<u>Item Number</u>	<u>Item</u>	<u>Cost</u>
20	Bare Module Annual Costs	Direct annual costs from model ^a
21	Overhead	0% of item 16 ^b
22	Monitoring	See footnote c
23	Taxes and Insurance	1% of item 16
24	Amortization	CRF x item 16 ^d
25	Total Annualized Costs	Item 20 + items 21 through 24

^aDirect annual costs include costs of raw materials, energy, operating labor, maintenance and repair.

^bItem 16 is the total depreciable investment obtained from Table VIII-4.

^cSee page ___ for an explanation of the determination of monitoring costs.

^dThe capital recovery factor (CRF) was used to account for depreciation and the cost of financing.

TABLE VIII-7
WASTEWATER SAMPLING FREQUENCY

Wastewater Discharge (l/day)	Sampling Frequency
0 - 37850	Once per month
36851 - 189250	Twice per month
189251 - 378500	Once per week
378501 - 946250	Twice per week
946251 - & above	Three times per week

TABLE VIII-8

COST PROGRAM POLLUTANT PARAMETERS

Parameter	Units
Flow rate	mg/l
pH	mg/l
Temperature	mg/l
Total suspended solids	mg/l
Acidity (as CaCO ₃)	mg/l
Aluminum	mg/l
Ammonia	mg/l
Antimony	mg/l
Arsenic	mg/l
Cadmium	mg/l
Chromium (+3)	mg/l
Chromium (+6)	mg/l
Cobalt	mg/l
Copper	mg/l
Cyanide (free)	mg/l
Cyanide (total)	mg/l
Fluoride	mg/l
Germanium	mg/l
Iron	mg/l
Lead	mg/l
Manganese	mg/l
Molybdenum	mg/l
Nickel	mg/l
Oil and Grease	mg/l
Phosphorus	mg/l
Selenium	mg/l
Silver	mg/l
Thallium	mg/l
Tin	mg/l
Titanium	mg/l
Zinc	mg/l

Table VIII-9

FLOW REDUCTION RECYCLE RATIO AND ASSOCIATED COST ASSUMPTIONS

Condition	Action
<u>Option A:</u>	
1. Actual flow from process* is greater than Option A.	1. Reduce flow to Option A at zero cost. Use flow to cost central treatment system.
2. Actual flow from process is less than Option A.	2. Use actual plant flow to cost central treatment plant.
<u>Options B and C:</u>	
1. Actual flow from process is greater than Option A and <u>no</u> in-process flow reduction techniques are in place.	1. Reduce flow to Option A at zero cost. Reduce flow to Option B using recycle ratio.*
2. Actual flow from process is greater than Option A. The actual plant recycle ratio is known and results in a flow less than Option A but <u>greater</u> than Option B.	2. Reduce flow to Option A at zero cost. Reduce flow to Option B using recycle ratio.
3. Actual flow from process is greater than Option A. The actual plant recycle ratio is known and results in a flow <u>less</u> than Option B.	3. Reduce flow to Option A at zero cost. Set discharge from flow reduction equipment equal to actual plant <u>reduced</u> flow.
4. Actual flow from process is greater than Option A and the actual plant recycle is unknown.	4. Reduce flow to Option A at zero cost. Reduce flow to Option B using constant recycle ratio.

345

Table VIII-9 (Continued)

FLOW REDUCTION RECYCLE RATIO AND ASSOCIATED COST ASSUMPTIONS

Condition	Action
5. Actual flow from process is less than Option A (but greater than Option B) and the actual plant recycle ratio is known and results in a flow less than Option B.	5. Set discharge from flow reduction equipment equal to actual plant <u>reduced</u> flow.
6. Actual flow from process is less than Option A (but greater than Option B) and the actual plant recycle ratio is unknown, zero, or results in a flow greater than Option B.	6. Set discharge from flow reduction equipment equal to Option B.
7. Actual flow from process is less than Option B using <u>no</u> flow reduction techniques.	7. Set discharge equal to actual plant flow.

346

*Flow before any reported flow reduction techniques (i.e., holding tanks, cooling towers, thickeners).

**The constant recycle ratio is calculated as: $R = \frac{\text{Option A Flow} - \text{Option B Flow}}{\text{Option A Flow}}$

Note:

Option A = Lime and settle.

Option B = Lime and settle with in-process flow reduction.

Option C = Lime, settle, and multimedia filtration with in-process flow reduction.

Table VIII-10

NONFERROUS METALS MANUFACTURING (PHASE I) COMPLIANCE COSTS
SECONDARY SILVER SUBCATEGORY
PLANT XXXX
DISCHARGE STATUS: INDIRECT

Equipment	Option A				Option B				Option C			
	Run	Total Capital	Required Capital	Annual	Run	Total Capital	Required Capital	Annual	Run	Total Capital	Required Capital	Annual
Cyanide Precipitation												
Ammonia Steam Stripping												
Cooling Towers												
Equalization	1	2,800	2,800	1,900	1	2,800	2,800	1,900	1	2,800	2,800	1,900
Chemical Precipitation	1	9,000	9,000	4,300	1	9,000	9,000	4,300	1	9,000	9,000	4,300
Gravity Settling		(4)				(4)				(4)		
Vacuum Filtration		(5)				(5)				(5)		
Multimedia Filtration												
Contract Hauling	1	0	0	1,300	1	0	0	1,300	1	1,700	1,700	1,200
Hold Tanks, Recycle	1	3,600	3,600	900	1	3,600	3,600	900	1	0	0	1,300
Segregation Costs		6,500	6,500	0		6,500	6,500	0		3,600	3,600	900
Subtotal		21,900	21,900	8,400		21,900	21,900	8,400		6,500	6,500	0
System Capital Costs		8,212	8,212			8,212	8,212			8,850	8,850	
Enclosure				0				0				0
Insurance and Taxes				301				301				324
Amortization				5,329				5,329				5,743
Monitoring				1,440				1,440				1,440
TOTAL		30,112	30,112	15,470		30,112	30,112	15,470		32,450	32,450	17,107

FOOTNOTES:

- All costs are in March, 1982 dollars.
- System capital costs are calculated as 37.5 percent of the total direct capital costs (capital subtotal).
- Amortization is calculated as 17.7 percent of the total required capital costs.
- Chemical precipitation operated in batch mode; gravity settling not costed.
- Flow to vacuum filter is less than minimum for sizing (42 l/hr). Stream is contract hauled.

347

GENERAL DEVELOPMENT DOCUMENT
SECT - VIII

TABLE VIII-11

NONFERROUS METALS MANUFACTURING WASTE GENERATION
(tons/yr)

<u>Subcategory</u>	<u>Discharger Type</u>	
	<u>Direct</u>	<u>Indirect</u>
Primary Aluminum	734336	NA
Secondary Aluminum	*	5697
Primary Copper	*	NA
Secondary Copper	*	*
Secondary Silver	1878	2893
Primary Lead	65 _a	NA
Primary Zinc	3.5 _a	0.6 _a
Metallurgical Acid Plants	88 _a	3.4 _a
Primary Tungsten	896	1212
Primary Columbium & Tantalum	17932	25003
Secondary Lead		
Primary Antimony	3361	0
Bauxite Refining	0	0
Primary Beryllium	695	0
Primary Boron	0	0
Primary Cesium and Rubidium	0	0
Primary & Secondary Germanium & Gallium	0	108
Secondary Indium	0	170
Secondary Mercury	0	0
Primary Molybdenum & Rhenium	1682	0
Secondary Molybdenum & Vanadium	850	0
Primary Nickel and Cobalt	10.4	0
Secondary Nickel	0	423
Primary Precious Metals & Mercury	11.4	0
Secondary Precious Metals	524	1585
Primary Rare Earth Metals	0	17
Secondary Tantalum	173	0
Secondary Tin	2762	19.3
Primary & Secondary Titanium	339	50.2
Secondary Tungsten & Cobalt	562	0.2
Secondary Uranium	320	0
Primary Zirconium & Hafnium	2624	5.6

* Solid waste generation accounted for by existing BPT regulation
a - Sulfide precipitation sludge

TABLE VIII-12

NONFERROUS METALS MANUFACTURING ENERGY CONSUMPTION
(kW-hr/yr)

<u>Subcategory</u>	<u>BPT</u>	<u>BAT</u>	<u>PSES</u>
Primary Aluminum	*	11079204	NA
Secondary Aluminum	*	884061	1613178
Primary Copper	*	166302	NA
Secondary Copper	*	*	179190
Secondary Silver	662074	711872	217053
Primary Lead	125247	1100028	NA
Primary Zinc	*	69564	13706
Metallurgical Acid Plants	*	469968	16666
Primary Tungsten	4600400	4641860	904665
Primary Columbium & Tantalum	3373589	3406603	1859916
Secondary Lead	1727280	1813408	3607300
Primary Antimony	393800	396500	NA
Bauxite Refining	0	0	NA
Primary Beryllium	1067300	1137000	NA
Primary Boron	0	0	0
Primary Cesium and Rubidium	0	0	0
Primary & Secondary Germanium & Gallium	0	0	6253
Secondary Indium	NA	NA	5900
Secondary Mercury	0	0	0
Primary Molybdenum & Rhenium	1261200	1267200	NA
Secondary Molybdenum & Vanadium	926000	936000	NA
Primary Nickel and Cobalt	20600	28570	NA
Secondary Nickel	NA	NA	88300
Primary Precious Metals & Mercury	4224	5155	NA
Secondary Precious Metals	489000	497000	4981000
Primary Rare Earth Metals	43500	39400	26000
Secondary Tantalum	16000	18000	NA
Secondary Tin	576000	581000	319200
Primary & Secondary Titanium	680340	687150	340300
Secondary Tungsten & Cobalt	1150000	1185000	3700
Secondary Uranium	57000	66000	NA
Primary Zirconium & Hafnium	12210000	12264000	NA

NOTE: NA = not applicable

* Energy consumption was considered for the promulgated BPT regulation; no additional energy consumption is attributed to this regulation.

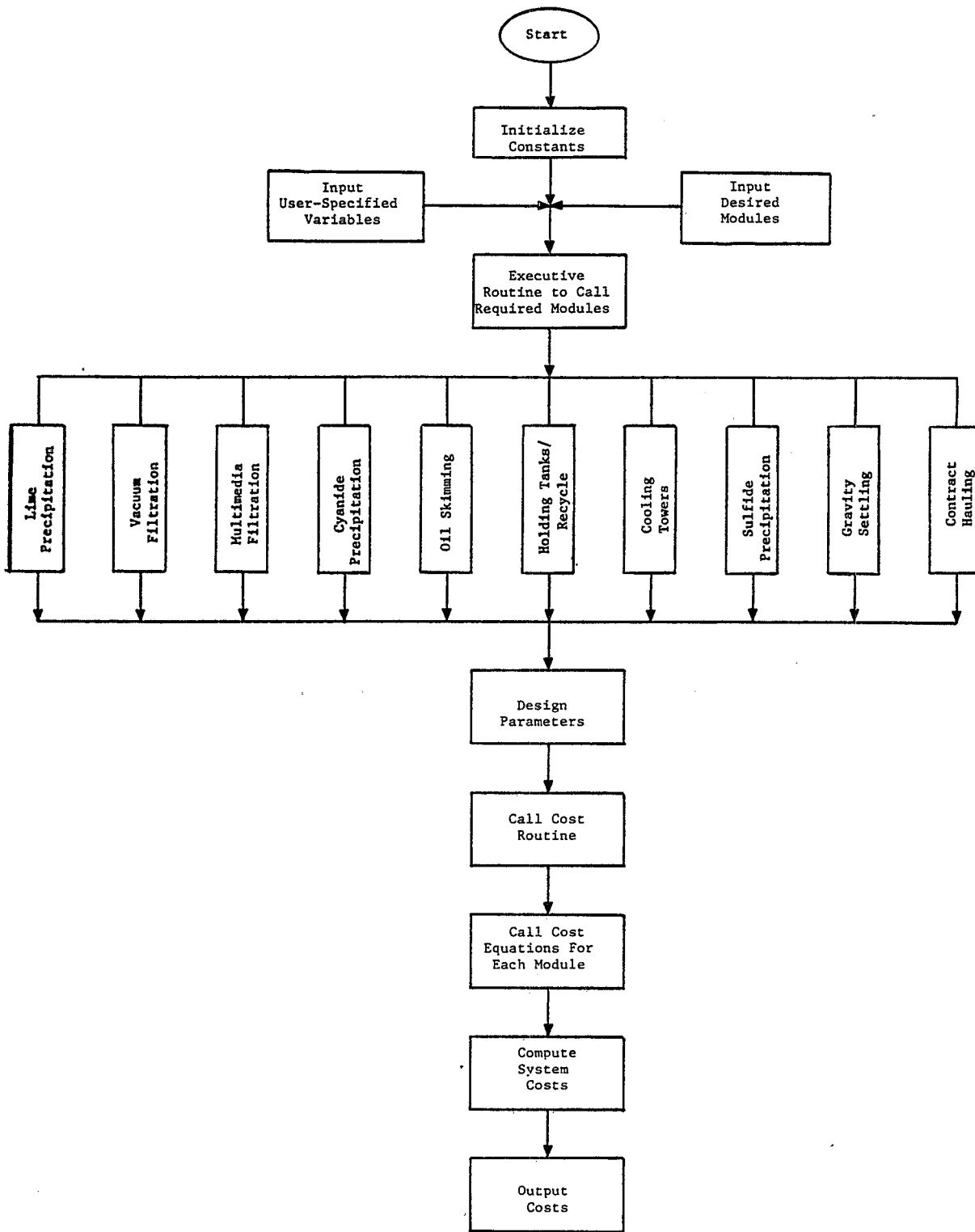

Figure VIII-1

GENERAL LOGIC DIAGRAM OF COMPUTER COST MODEL

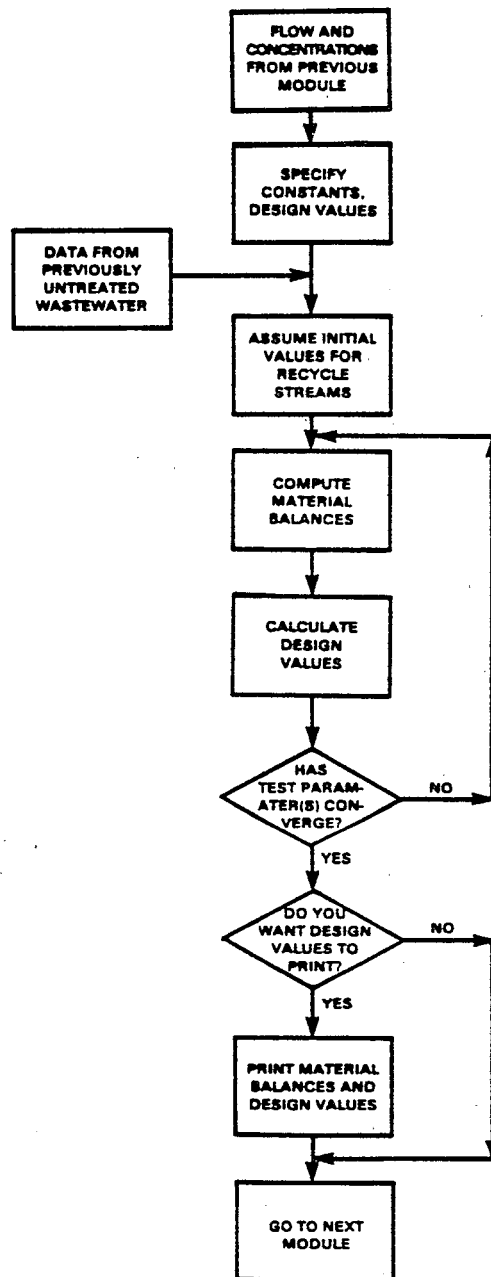

Figure VIII-2

LOGIC DIAGRAM OF MODULE DESIGN PROCEDURE

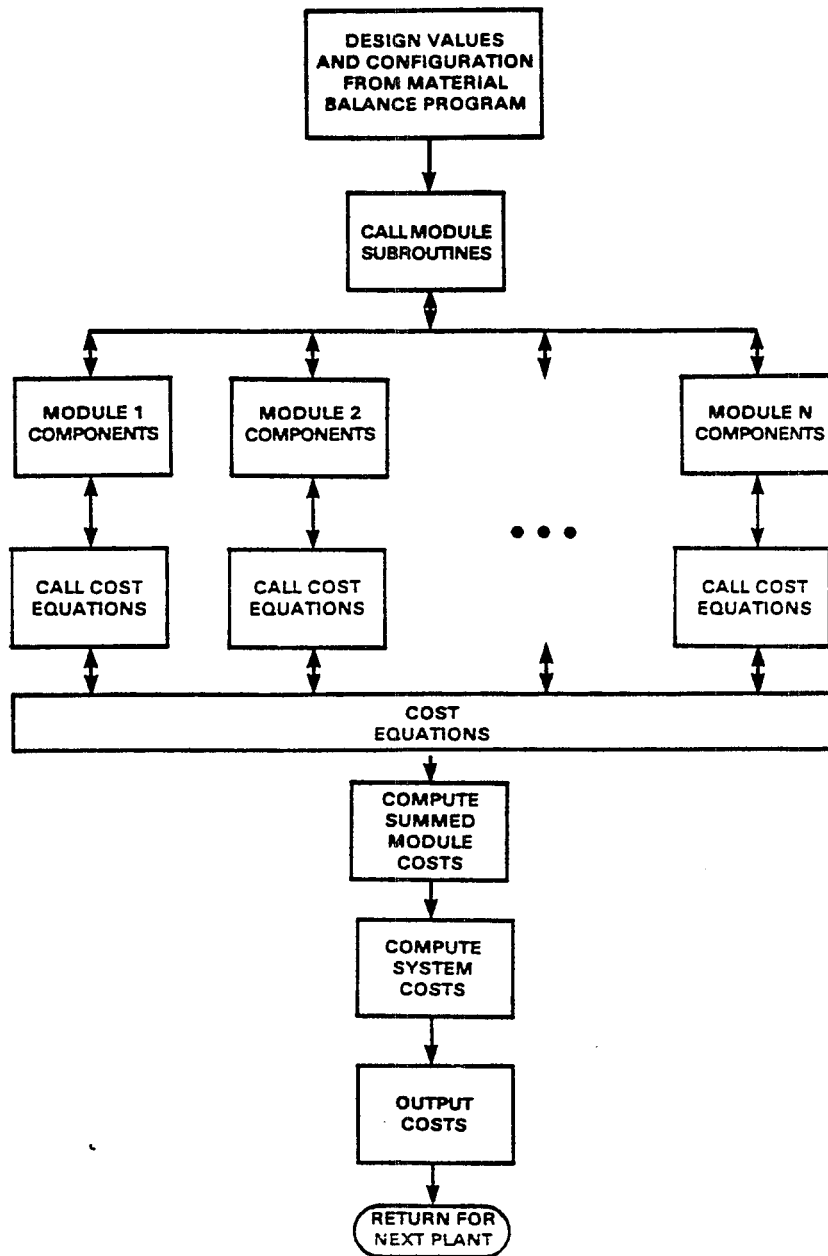

Figure VIII-3

LOGIC DIAGRAM OF THE COST ESTIMATION ROUTINE

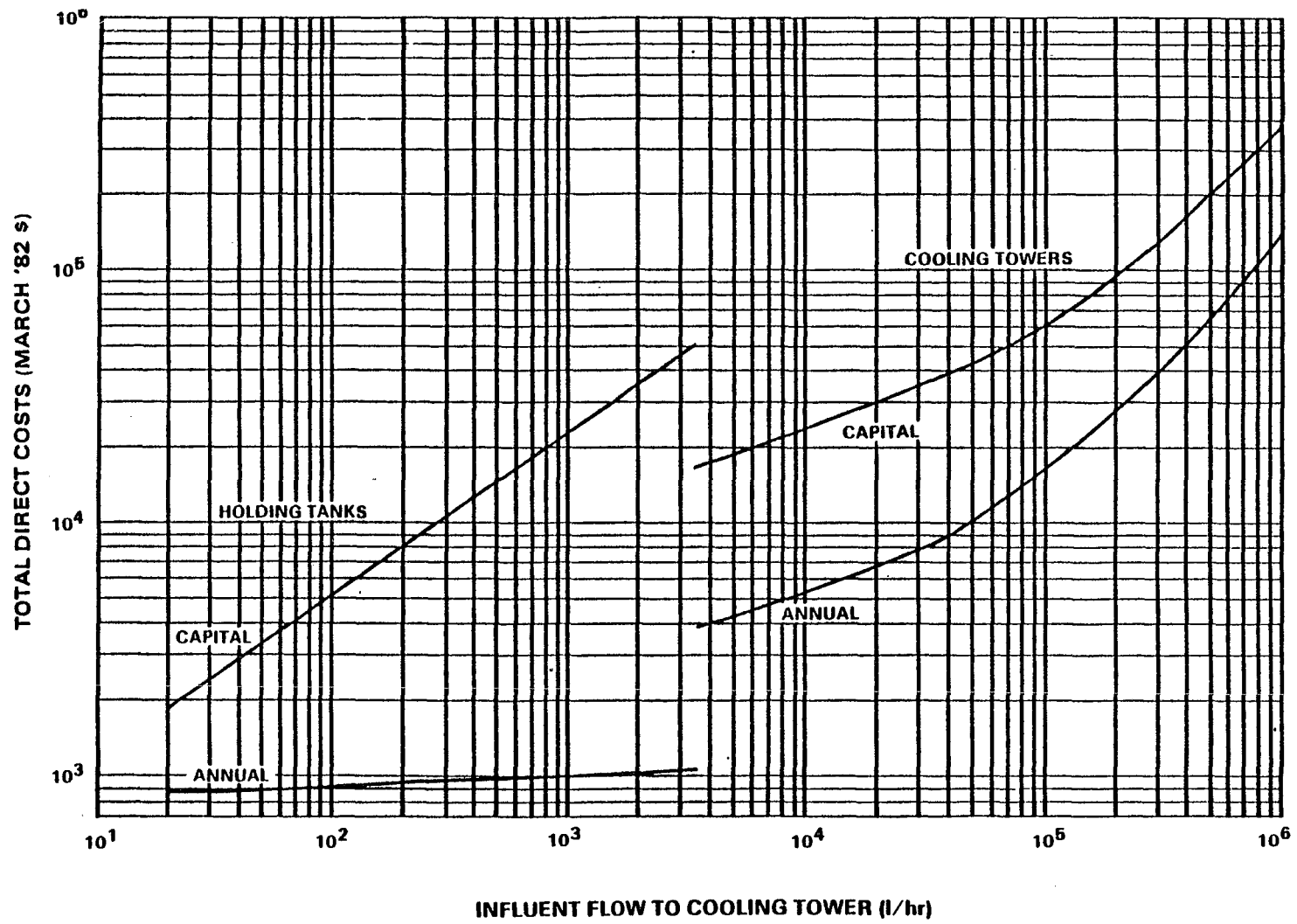

Figure VIII-4
CAPITAL AND ANNUAL COSTS FOR COOLING TOWER/HOLDING TANK

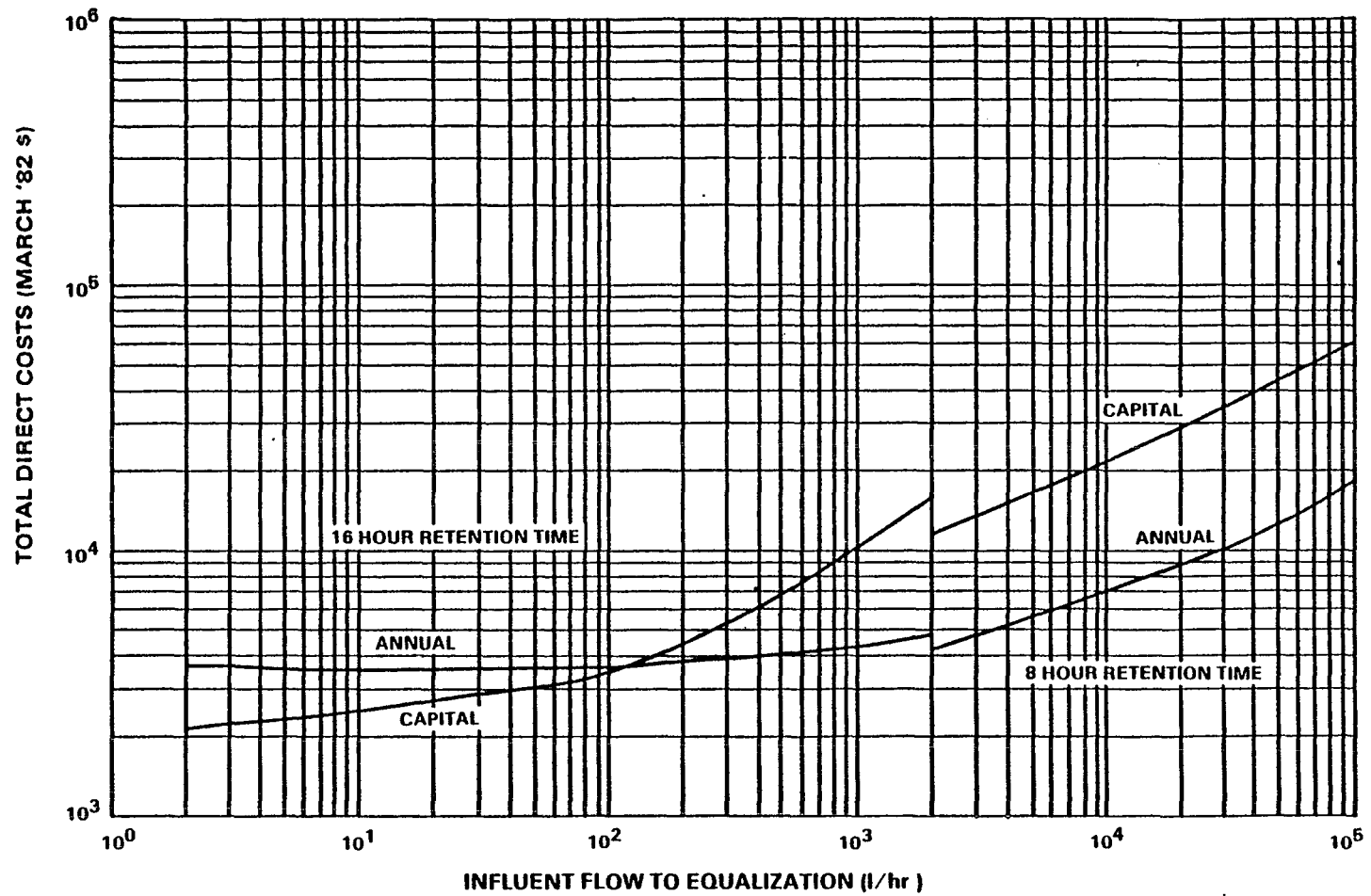

Figure VIII-5
CAPITAL AND ANNUAL COSTS FOR FLOW EQUALIZATION

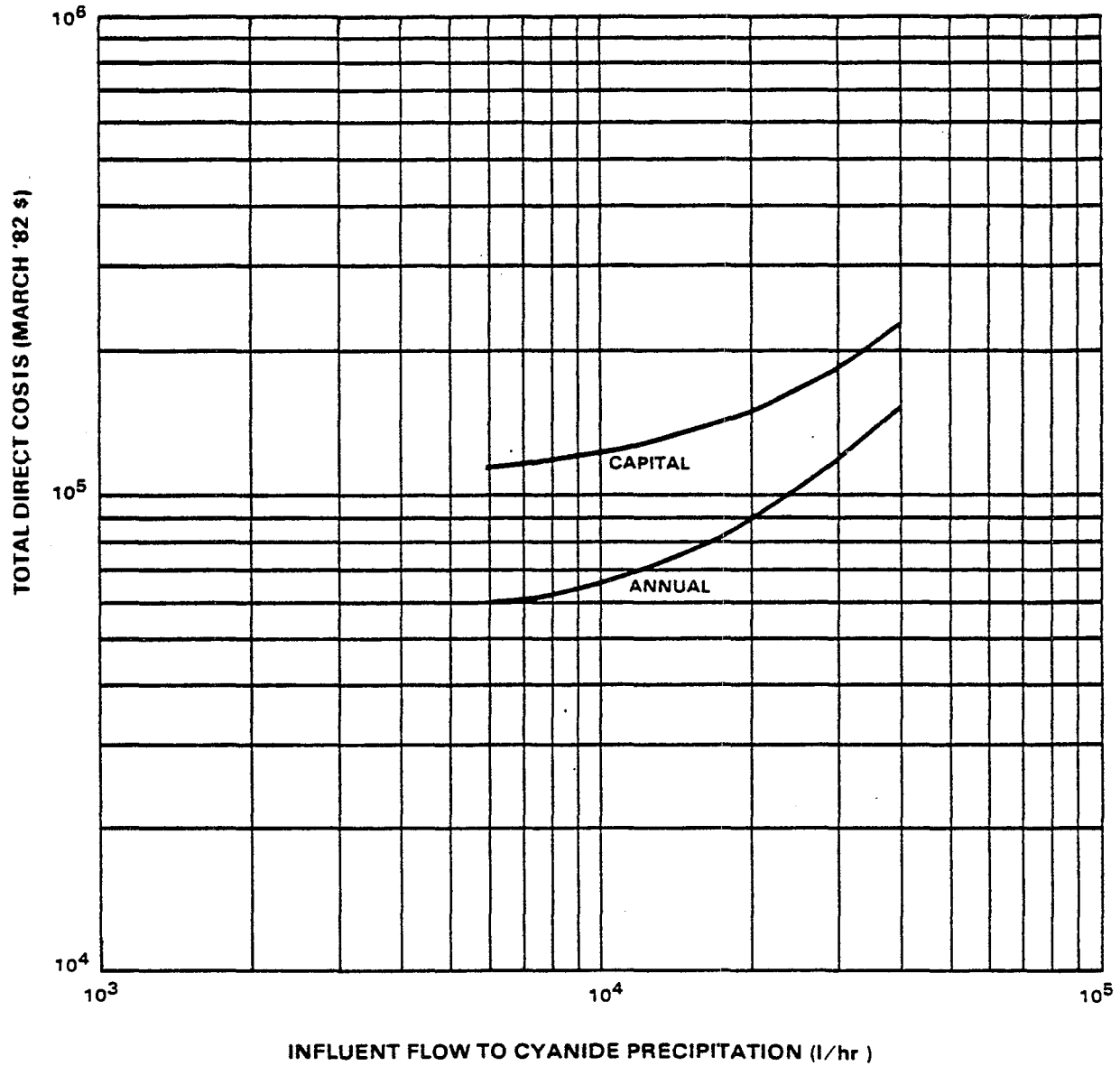

Figure VIII-6
 CAPITAL AND ANNUAL COSTS FOR CYANIDE PRECIPITATION

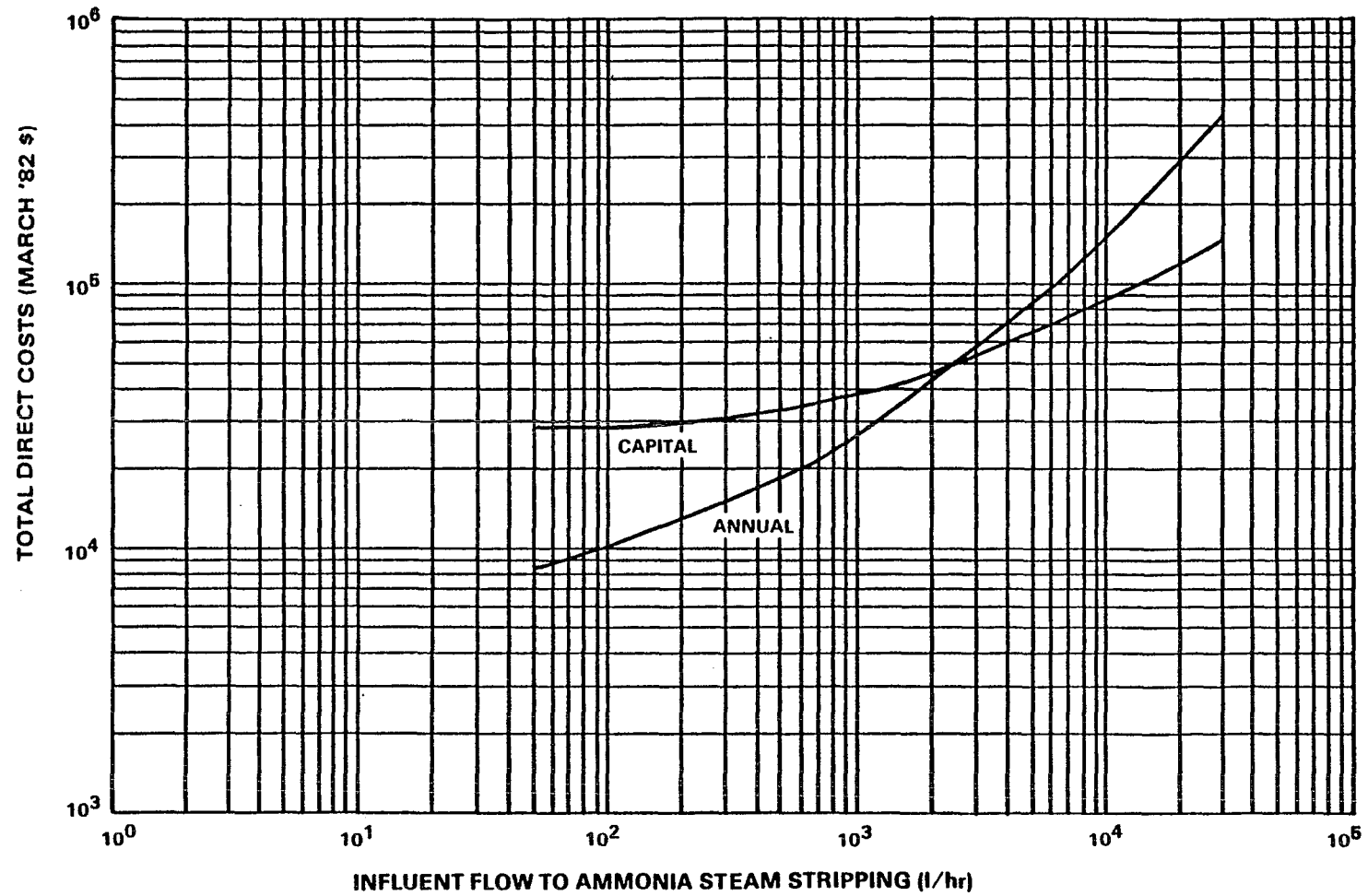

Figure VIII-7

CAPITAL AND ANNUAL COSTS FOR AMMONIA STEAM STRIPPING

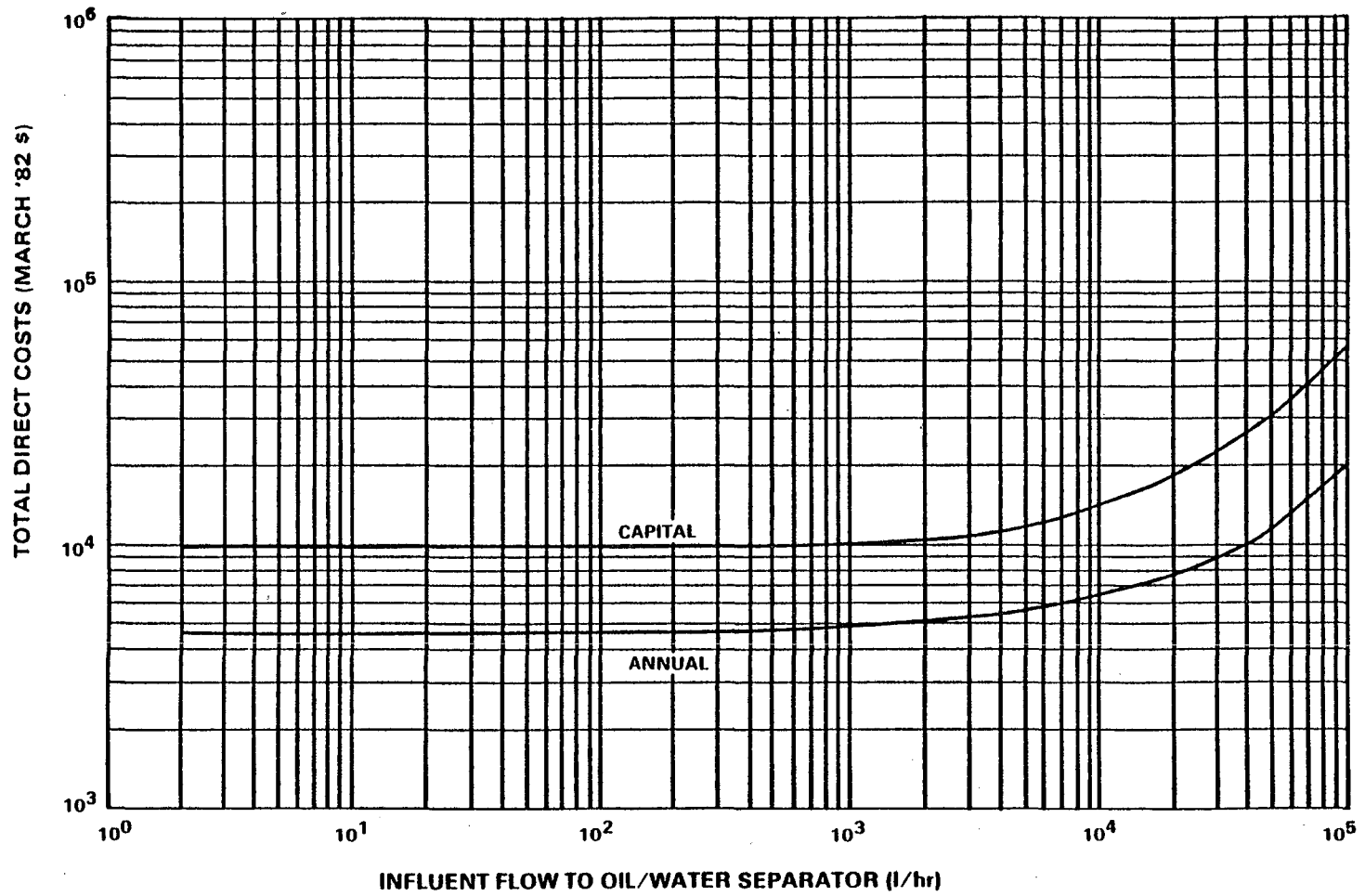

Figure VIII-8
CAPITAL AND ANNUAL COSTS FOR OIL/WATER SEPARATION

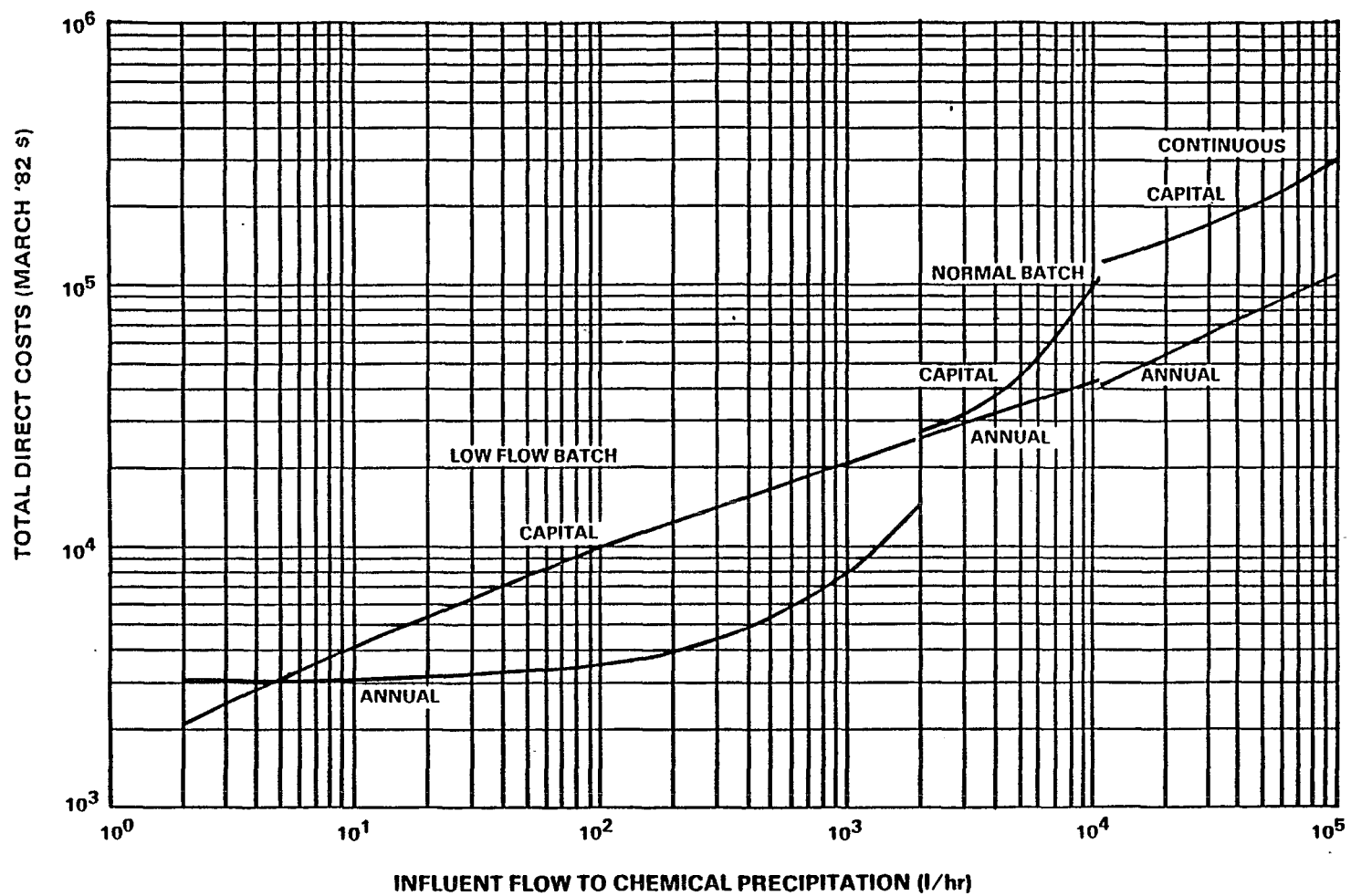

Figure VIII-9
CAPITAL AND ANNUAL COSTS FOR CHEMICAL PRECIPITATION

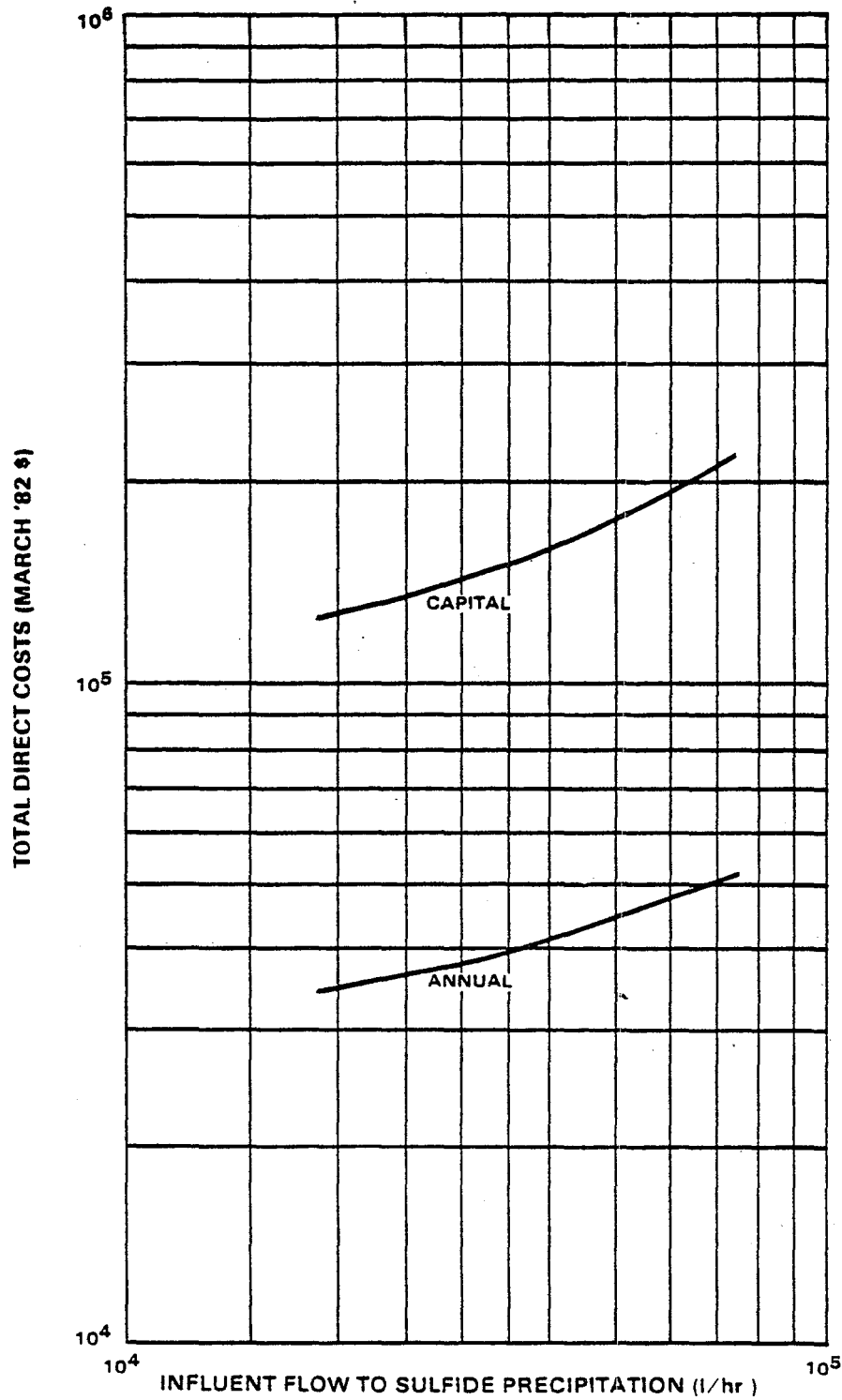

Figure VIII-10

CAPITAL AND ANNUAL COSTS FOR SULFIDE PRECIPITATION

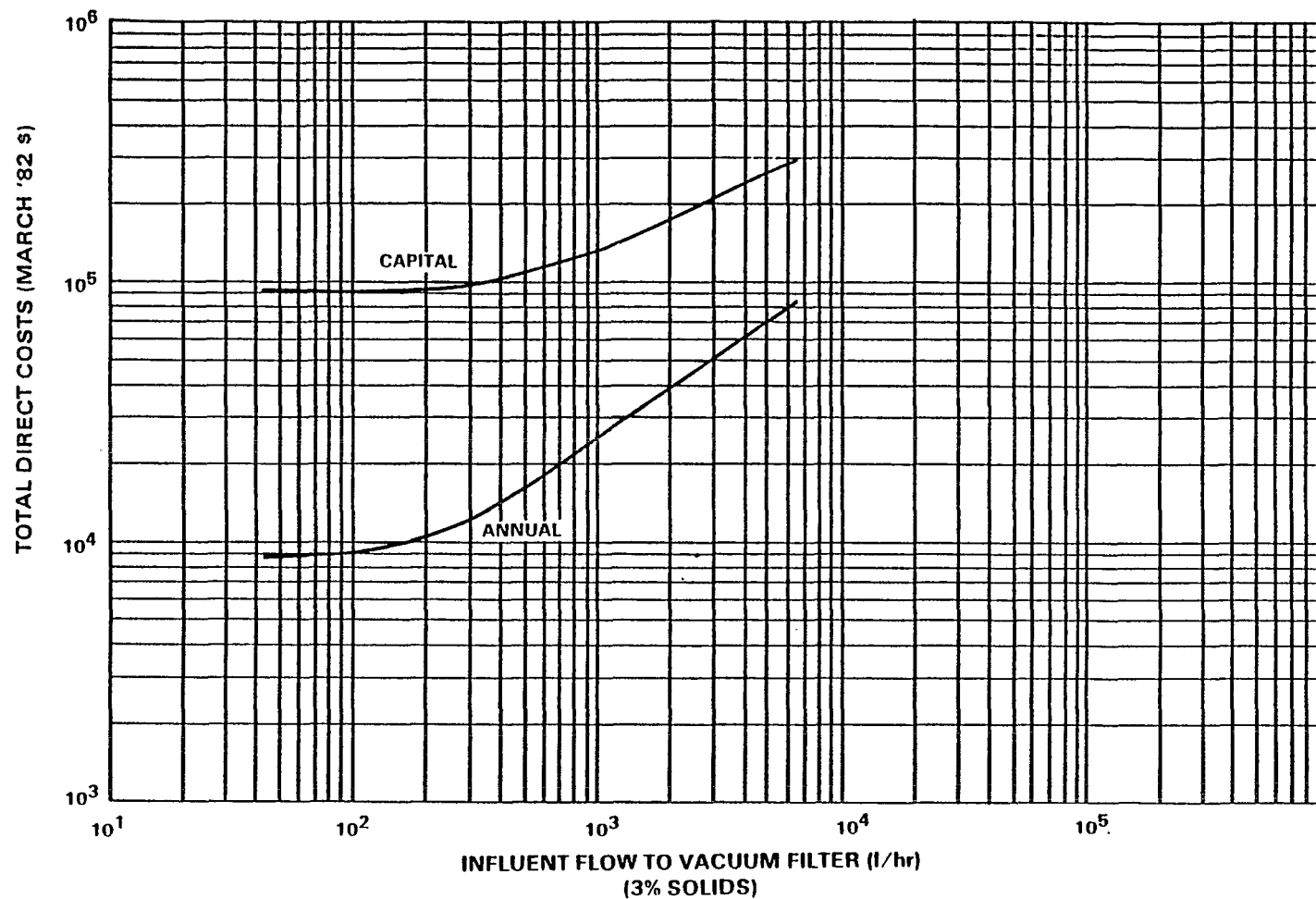

Figure VIII-11

CAPITAL AND ANNUAL COSTS FOR VACUUM FILTRATION

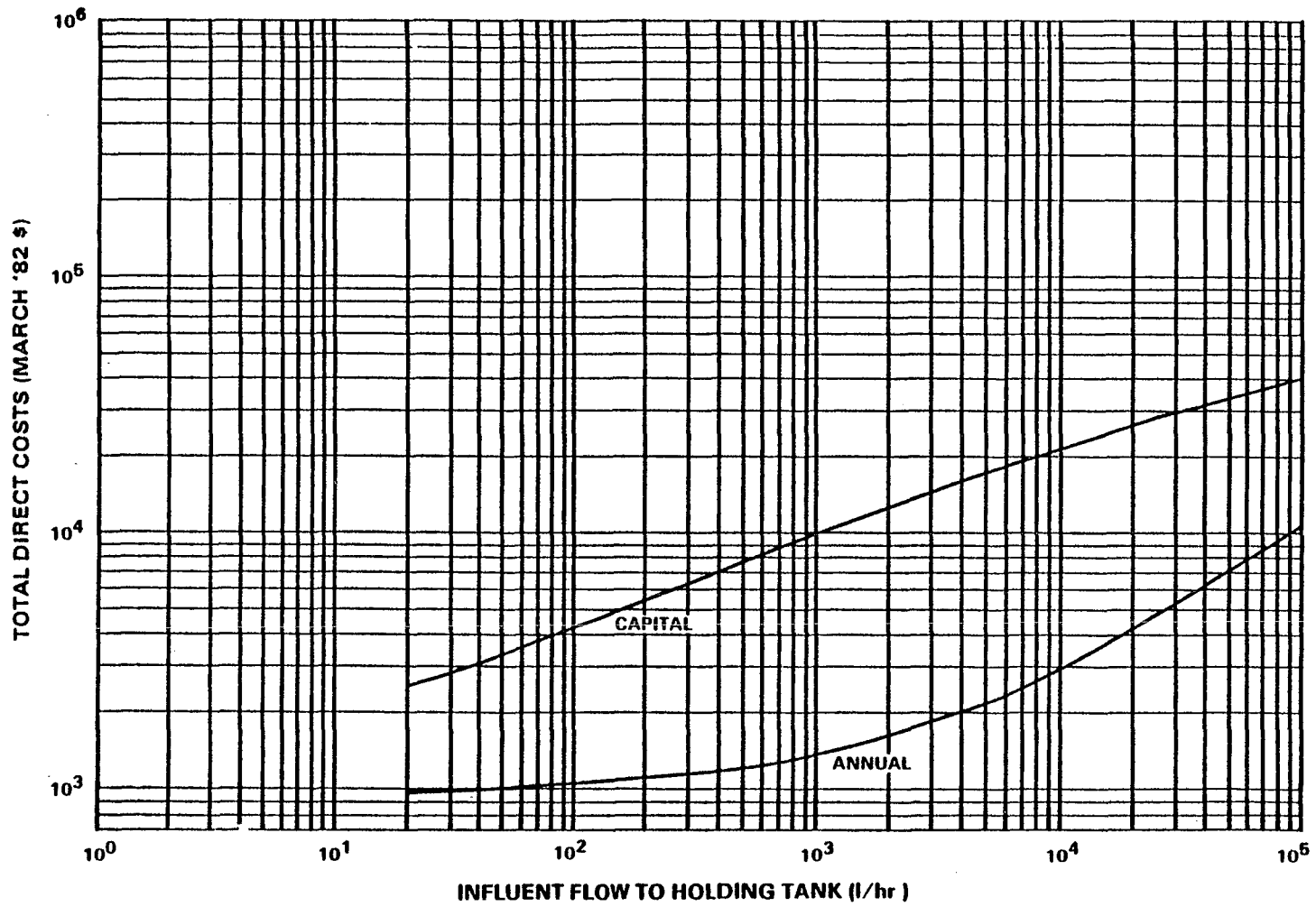

Figure VIII-12

CAPITAL AND ANNUAL COSTS FOR HOLDING TANKS/RECYCLE

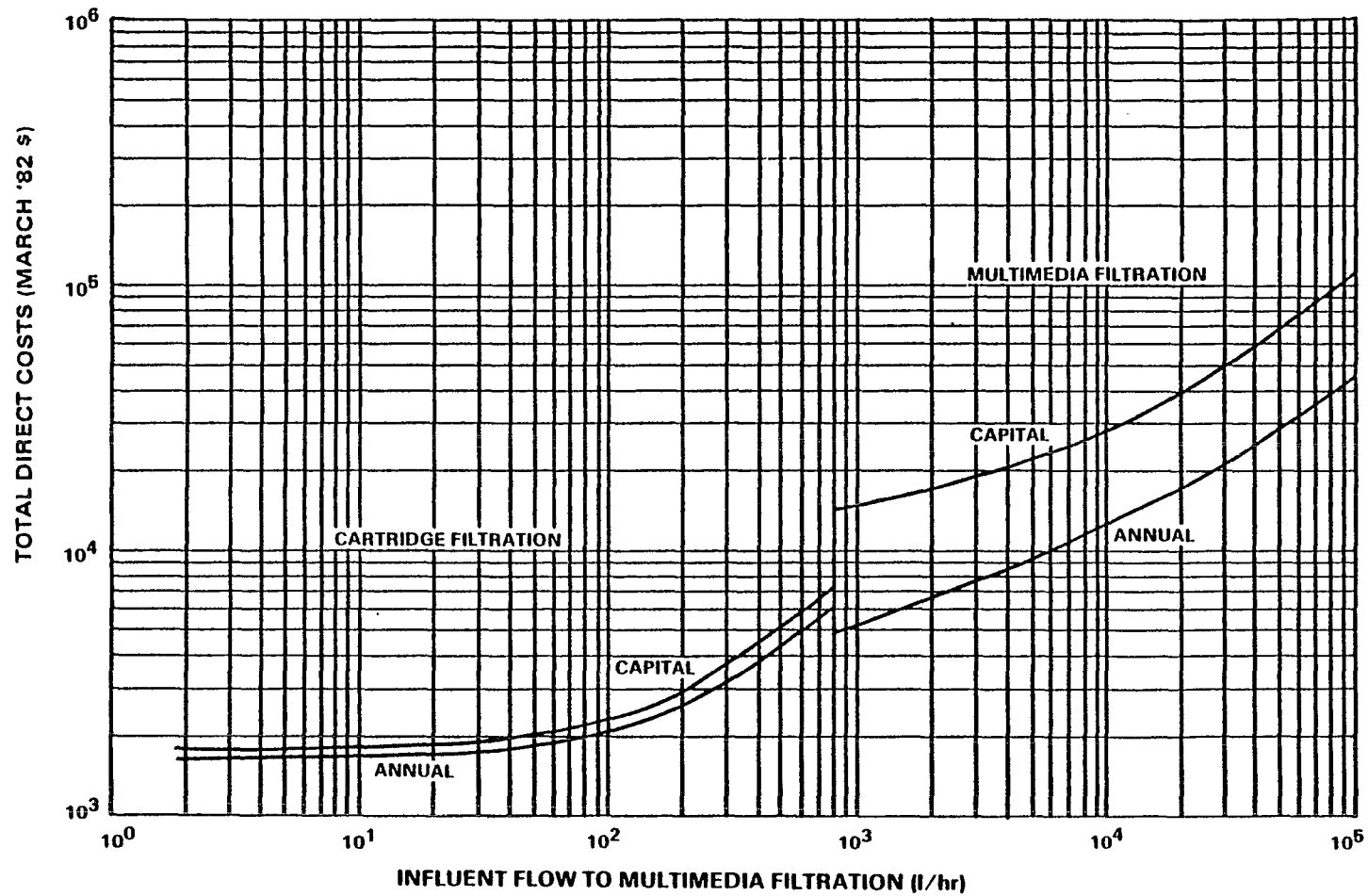

Figure VIII-13

CAPITAL AND ANNUAL COSTS FOR MULTIMEDIA FILTRATION

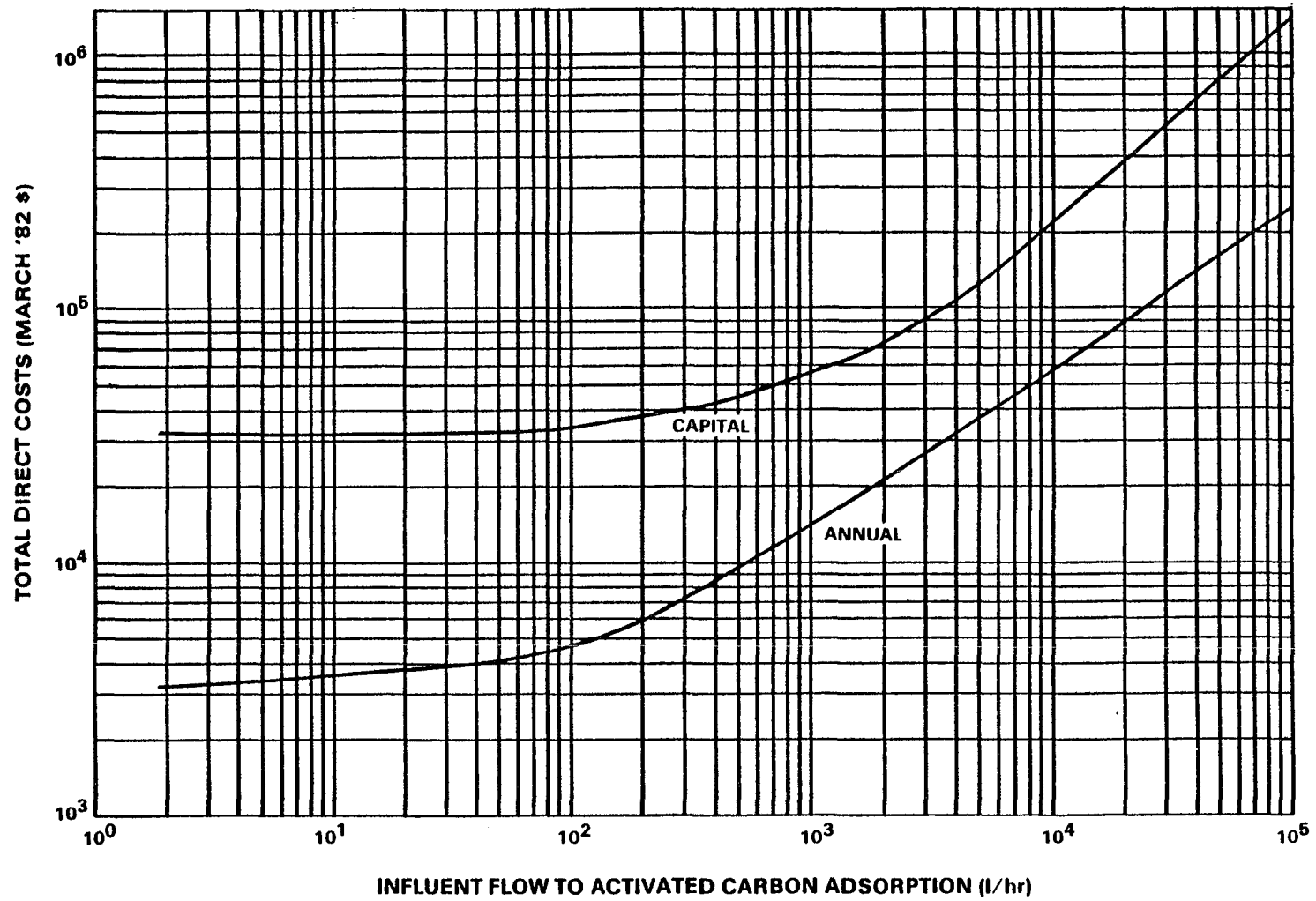

Figure VIII-14

CAPITAL AND ANNUAL COSTS FOR ACTIVATED CARBON ADSORPTION

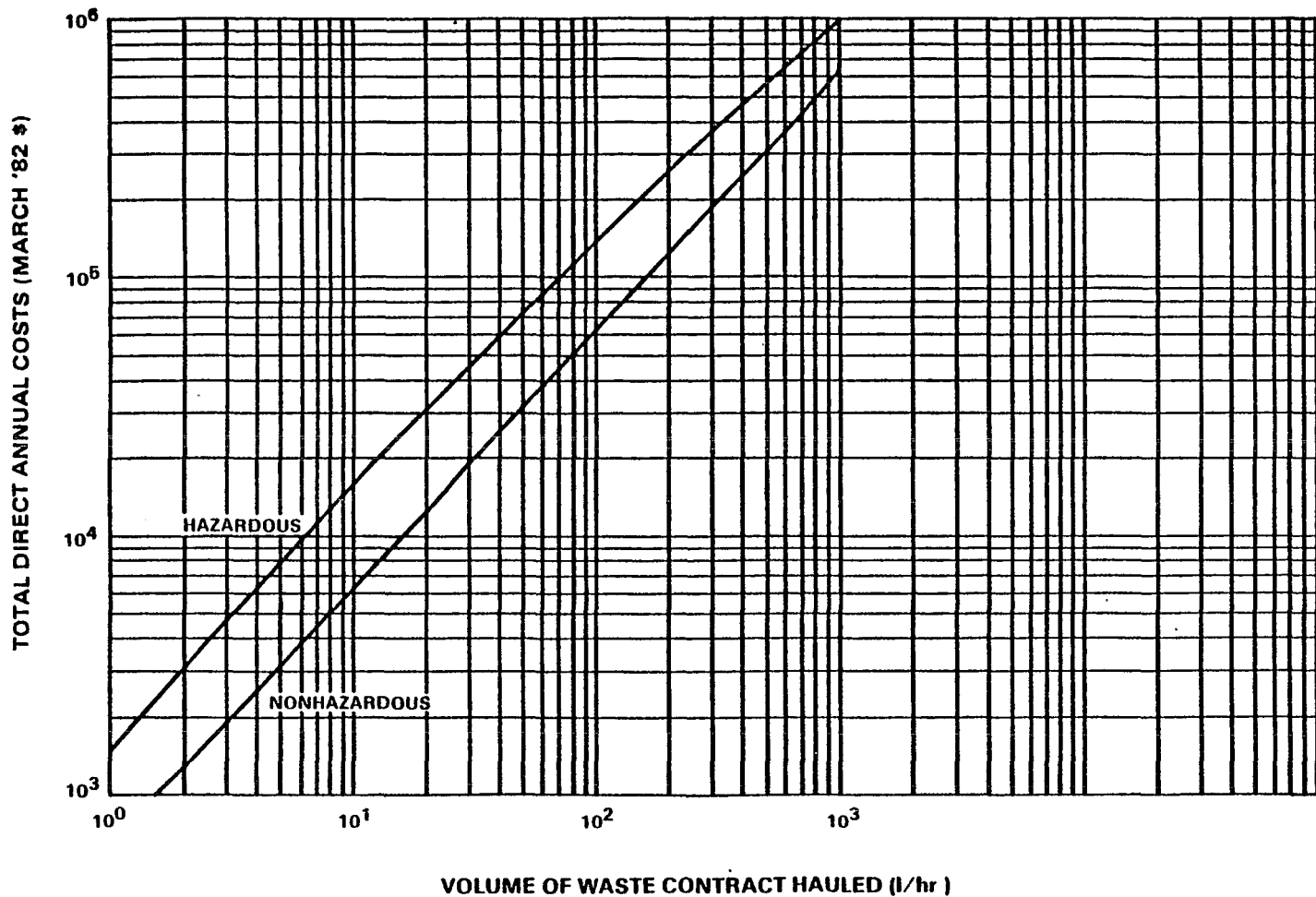

Figure VIII-15
COSTS FOR CONTRACT HAULING

SECTION IX

EFFLUENT QUALITY ATTAINABLE THROUGH APPLICATION OF THE
BEST PRACTICABLE CONTROL TECHNOLOGY CURRENTLY AVAILABLE

This section sets forth the effluent limitations attainable through the application of best practicable control technology currently available (BPT). It also serves to summarize changes from previous rulemakings in the nonferrous metals manufacturing category, and presents the development and use of the mass-based production related effluent limitations.

A number of considerations guide the BPT analysis. First, effluent limitations based on BPT generally reflect performance levels achieved at plants in each subcategory equipped with the best wastewater treatment facilities. The BPT analysis emphasizes treatment facilities at the end of a manufacturing process but can also include in-plant control techniques when they are considered to be normal practice within the subcategory. Finally, the Agency closely examines the effectiveness of the various treatment technologies by weighing the pollutant removals achievable by each treatment alternative and by assessing installation and operational costs.

The limitations are organized by subcategory, and are presented in Section II of each subcategory supplement.. The limitations were developed based on the sampling, treatment effectiveness, and cost data that have been presented in this document.

TECHNICAL APPROACH TO BPT

In the past, the technical approach for the nonferrous metals manufacturing category considered each plant as a single wastewater source, without specific regard to the different unit processes that are used in plants within the same subcategory. This approach may be appropriate for BPT which is generally based upon end-of-pipe technology. In-process controls are generally not used to establish BPT; however, they may be used as the basis of BPT when they are widely used in the category. In reviewing the existing BAT regulations and developing new BAT regulations, the Agency closely examined each process and the potential for implementing in-process controls. It became apparent that it was best to establish effluent limitations and standards recognizing specific waste streams associated with specific manufacturing operations. This also results in more effective pollution abatement by tailoring the regulation to reflect these various wastewater sources. Currently promulgated BPT effluent limitations and standards which have been developed using this approach generally have not been modified.

This approach, referred to as the building block approach, establishes pollutant discharge limitations for each source of wastewater identified within the subcategory. Each wastewater

source is allocated a discharge based on the average reported discharge rates for that source. These flows are normalized (related to a common basis) using a characteristic production parameter associated with the wastewater source (e.g. volume of wastewater discharged per unit mass of production). The mass limitations established for a wastewater source are obtained by multiplying the effluent concentrations attainable by the selected BPT technology by the regulatory (production normalized) flow for each wastewater source. Thus, the specific pollutant discharge allowances for a plant's final discharge permit are calculated by multiplying the appropriate production rates with the corresponding mass limitations for each wastewater source in that plant, and then summing the results. This calculation is performed to obtain the one-day maximum and the monthly average limitations. It is important to note that the plant need only comply with the total mass limitations for the discharge and not the flow allowances or concentrations. In cases where process wastewaters and nonprocess waters not specifically regulated by this proposal are discharged together from a facility, the permit authority must treat the nonprocess segment on a case-by-case basis.

Although each waste stream may not include each selected pollutant, discharge allowances are provided for all pollutants in every waste stream from the same subcategory because each waste stream contributes to the total loading of a combined waste treatment system. Since a discharge allowance is included for each pollutant in every waste stream, facilities would not be required to reduce pollutant concentrations below the performance limits of the technology. Instead, this approach allows plants to achieve the performance determined for the technology at the plant discharge point. Therefore, the mass limitation for each pollutant in each building block is the product of the concentration achievable by the technology basis of the limitation and the regulatory flow for that building block.

In determining the technology basis for BPT, the Agency reviewed a wide range of technology options and selected four alternatives which could be applied to nonferrous metals manufacturing as BPT options. These options include:

1. Option A - End-of-pipe treatment consisting of chemical precipitation and clarification, and preliminary treatment, where necessary, consisting of oil skimming, cyanide precipitation, sulfide precipitation, iron coprecipitation, and ammonia air or steam stripping. This combination of technologies reduces toxic metals and cyanide, conventional, and nonconventional pollutants. Ion exchange end-of-pipe treatment is also included in Option A where necessary to reduce certain nonconventional pollutants.
2. Option B - Option B is equal to Option A preceded by flow reduction of process wastewater through the use of cooling towers for contact cooling water and holding tanks for all other process wastewater subject to recycle.

3. Option C - Option C is equal to Option B plus end-of-pipe polishing filtration for further reduction of priority metal pollutants and TSS.
4. Option E - Option E consists of Option C plus activated carbon adsorption applied to the total plant discharge as a polishing step to reduce toxic organic concentrations.

Two additional technologies, activated alumina and reverse osmosis, were evaluated prior to proposing mass limitations for this category. Activated alumina treatment was included for reduction of fluoride and arsenic concentrations. Reverse osmosis was considered so that complete recycle of all process wastewater could be attained. However, both of these technologies were rejected because they are not demonstrated in the nonferrous metals manufacturing category, nor are they clearly transferable.

For each of the selected options, the mass of pollutant removed and the costs associated with application of the option were estimated. A description of the pollutant removal estimates associated with the application of each option is presented in Section X, while the cost methodology is presented in Section VIII.

MODIFICATIONS TO EXISTING BPT EFFLUENT LIMITATIONS

Prior to this rulemaking session, BPT effluent limitations were promulgated for nine of the 31 nonferrous metals manufacturing subcategories:

1. bauxite refining,
2. primary aluminum smelting,
3. secondary aluminum smelting,
4. primary copper smelting,
5. primary electrolytic copper refining,
6. secondary copper,
7. primary lead,
8. primary zinc, and
9. metallurgical acid plants.

On February 17, 1983, four new subcategories were proposed for inclusion in the nonferrous metals manufacturing point source category (48 FR 7032). No effluent limitations had previously been promulgated for these subcategories.

1. primary tungsten,
2. primary columbium-tantalum,
3. secondary silver, and
4. secondary lead.

On June 27, 1984, 20 new subcategories were proposed for inclusion in the nonferrous metals manufacturing point source category (49 FR 26352.) There had been no previous effluent

limitations developed for these 20 subcategories. Following proposal, EPA decided to exclude two of the 20 subcategories, primary boron and primary cesium and rubidium, from regulation. The 20 new subcategories EPA proposed for regulation are listed below:

1. primary antimony
2. primary beryllium
3. primary boron
4. primary cesium & rubidium
5. primary and secondary germanium and gallium
6. secondary indium
7. secondary mercury
8. primary molybdenum and rhenium
9. secondary molybdenum and vanadium
10. primary nickel and cobalt
11. secondary nickel
12. primary precious metals and mercury
13. secondary precious metals
14. primary rare earth metals
15. secondary tantalum
16. secondary tin
17. primary and secondary titanium
18. secondary tungsten and cobalt
19. secondary uranium
20. primary zirconium and hafnium

EPA modified BPT effluent limitations for the primary lead subcategory and secondary aluminum subcategory because new data and information submitted to the Agency made it necessary to revise these limits. EPA is modified the metallurgical acid plants subcategory to include acid plants associated with primary molybdenum, primary zinc and primary lead. In addition, modifications were promulgated for existing stormwater exemptions previously promulgated in the primary lead subcategory.

PRIMARY LEAD

The 1975 promulgated BPT for this subcategory is based on the complete recycle and reuse of slag granulation wastewater (or dry slag dumping), dry air scrubbing, and treatment and impoundment (subject to allowances for net precipitation and catastrophic precipitation events) of acid plant blowdown. As mentioned earlier, acid plant wastewater is now included in the metallurgical acid plants subcategory. This suggests that BPT for primary lead should be zero discharge. Since 1975, however, additional data collected by the Agency support the need for discharge of wastewater from slag granulation. Although it was previously thought that slag granulation is a net water consuming operation, the additional data show that at least one plant uses an ore with a lead content sufficiently high to justify recycling blast furnace slag into the sintering machine to recover the remaining lead content. For this reason, EPA modified the 1975 promulgated BPT for this subcategory to allow a discharge from dross slag granulation operations.

METALLURGICAL ACID PLANTS

On February 17, 1983, EPA proposed to expand the metallurgical acid plants subcategory to include metallurgical acid plants at primary lead and primary zinc smelters as well as those at primary copper smelters.

On June 27, 1984, EPA proposed to include metallurgical acid plants associated (i.e., on-site) with primary molybdenum roasters as part of the metallurgical acid plants subcategory. These operations, which were previously regulated under their respective primary metal subcategories, are now subject to limitations for acid plants. All these plants would accordingly have identical effluent limitations and standards, with one exception: acid plants associated with primary molybdenum roasters would also have fluoride and molybdenum regulated in their effluent. In making this determination, that all acid plants be regulated in one subcategory, the Agency considered the way in which acid plants are operated when associated with the primary smelters and the characteristics of the wastewater generated by each type to acid plant. Our conclusion is that these processes, rate of process discharge, and wastewater matrices are similar, justifying a single subcategory for all acid plants.

Metallurgical acid plants are constructed on-site with primary copper, lead, zinc, and molybdenum smelters to treat the smelter emissions, remove the sulfur dioxide, and produce sulfuric acid as a marketable by-product. Although two basic technologies, single contact and double contact, are used in the industry, the Agency found no predominance of either technology in place in plants of the four metal types. Finally, the Agency found no difference in the characterization of the wastewater at plants which burn supplemental sulfur.

The processes are also similar in terms of waste streams generated. Wastewaters are typically combined in acid plants into a single waste stream (acid plant blowdown). Principal streams going into the blowdown (compressor condensate, blowdown from acid plant scrubbing, mist precipitation, mist elimination, and steam generation) are common to all four types of plants.

The wastewater matrices from all four types of acid plants also are similar. The Agency reviewed the analytical data that were obtained in sampling programs described in Section V and compared the characteristics of untreated acid plant blowdown from plants associated with each of the four primary metals considered. There were similar concentrations (i.e., in the same order of magnitude) of antimony, arsenic, chromium, mercury, and selenium, among the four. All of these metals were present at concentrations that are treatable to the same effluent concentration upon application of chemical precipitation and sedimentation or chemical precipitation, sedimentation and multimedia filtration, and are within the range used in

calculating treatment effectiveness for these technologies. One dissimilarity which was observed between molybdenum acid plant wastewater matrices and the matrices associated with other acid plants is that treatable concentrations of fluoride and molybdenum are present in molybdenum acid plant wastewaters and not in the wastewaters from other metallurgical acid plants. The Agency is establishing limitations for fluoride and molybdenum in discharges from metallurgical acid plants associated with primary molybdenum roasters. Molybdenum limitations are based on iron co-precipitation preliminary treatment.

Therefore, in light of these essential similarities of process, wastewater flow and composition, we have chosen to include all acid plants in a single subcategory.

MODIFIED APPROACH TO STORMWATER

Stormwater, in all effluent limitations and standards, is only considered process wastewater when commingled with actual process wastewater. If commingling occurs, the stormwater, which usually does not contain significant pollutant loadings, is contaminated with the pollutants contained in the process wastewater, and as such should be subject to treatment. No allowance, however, is given for this additional flow, since stormwater is or can be segregated from the process wastewater.

Existing BPT effluent limitations for the nonferrous metals subcategories primary copper smelting, secondary copper, and primary lead have promulgated stormwater exemptions. Facilities in these three subcategories are subject to a zero discharge requirement according to promulgated BPT effluent limitations; however, facilities meeting certain design capacity requirements could discharge, regardless of effluent quality, a volume of water falling within the impoundment in excess of the 10-year, 24-hour storm, when a storm of at least that magnitude occurred. Further, facilities in the secondary copper and primary lead subcategories can discharge once per month, subject to concentration-based effluent limitations, a volume of water equal to the difference between precipitation and evaporation falling on the impoundment in that month.

The Agency made some revisions to some of these impoundment-based regulations in 1980 for primary copper smelting and electrolytic refining BPT. The 1983-1989 rulemaking session promulgated revisions to others. The revised regulations are based on end-of-pipe treatment using hardware (lime precipitation and sedimentation technology using clarifiers). By eliminating impoundments, the need for a net precipitation allowance and stormwater discharge (subject to an exception discussed below) is eliminated.

The Agency is reluctant to issue limitations based on impoundments for a number of reasons:

1. Discharge from impoundments can be as a "slug,"

allowing potentially heavy and damaging pollutant loadings to be discharged all at once;

2. Impoundments allow dilution of heavily contaminated process wastewaters with relatively cleaner process streams;
3. Net precipitation limitations are hard to calculate because of periodic shifts between net precipitation and net evaporation;
4. Impoundments pose a risk of groundwater contamination; and,
5. Impoundment-based regulations effectively require the Agency to specify impoundment design.

For reference, see generally 45 FR at 44926 (July 2, 1980), revising impoundment-based regulations in the primary copper smelting and electrolytic refining subcategories. In addition, plants within these subcategories have, in many cases, already installed hardware-based lime precipitation and sedimentation technology, so that these technologies are now BPT or BAT for these subcategories.

In light of these considerations, an allowance for net precipitation is not included for BPT for the primary lead subcategory because the effluent limitations for BPT are not based on settling and evaporation impoundments. EPA is not promulgating any modifications to previously promulgated BPT effluent limitations for the primary copper smelting and secondary copper subcategories.

It is recognized that this approach to catastrophic rainfalls varies from the approach used for the ore mining and dressing category (47 FR 54603). In that regulation EPA required only that the impoundments be designed and operated so as to contain a 10-year, 24-hour storm, while this promulgated regulation requires that no discharge from the impoundment may occur except when a 10-year, 24-hour storm occurs. This difference is justified by the fact that the nonferrous metals manufacturing allowance applies only to water falling on the surface of the impoundment while the ore mining allowance applies to stormwater drainage from various processing locations at the ore mine and mill. The relative surface area of a nonferrous manufacturing impoundment is a small fraction of the area drained at an ore mine or mill. Therefore, the quantity of stormwater that must be contained at a nonferrous plant impoundment is much smaller, making containment of the stormwater under the provisions of this regulation achievable. The Agency believes that decisions regarding stormwater are site-specific and are best handled based on the judgment of individual permit writers.

BPT OPTION SELECTION

The treatment option selected for the technology basis of BPT throughout the category is Option A (chemical precipitation and sedimentation, with ammonia steam or air stripping, oil skimming, sulfide precipitation, iron co-precipitation and cyanide precipitation pretreatment, and ion-exchange end-of-pipe treatment where appropriate). Chemical precipitation, sedimentation, and ammonia stripping are widely demonstrated at plants with the best treatment practices in the nonferrous metals manufacturing category. Of the 240 discharging plants (shown by subcategory in table IX-1, (page 384), 133 plants have treatment to remove metals and suspended solids, one plant practices oil skimming, one plant has technology for cyanide precipitation, eight have technology for cyanide oxidation, 11 practice ammonia stripping, three employ ion exchange and 13 practice end-of-pipe filtration. The remainder of the dischargers did not report any treatment for their nonferrous metals manufacturing wastewaters. The preponderance of technology is chemical precipitation and sedimentation equipment. Multimedia filtration (Option C) as an add-on polishing step to the precipitation and sedimentation system was not selected at BPT since it was less widely demonstrated.

Recycle after treatment consisting of lime precipitation and sedimentation is practiced at one plant. Thirty-nine plants practice recycle of scrubber water without any treatment, and two plants practice recycle of process water using cooling towers.

Between 1975 and 1980, BPT effluent limitations were promulgated for nine of the 36 nonferrous metals manufacturing subcategories, namely, bauxite refining, primary aluminum, secondary aluminum, primary copper smelting, primary electrolytic copper refining, secondary copper, primary lead, primary zinc, and metallurgical acid plants. Of the remaining 27 subcategories, EPA has reserved setting BPT limitations for the following three subcategories because there are no existing direct discharging plants in these subcategories:

1. Secondary Indium
2. Secondary Mercury
3. Secondary Nickel

As discussed earlier, EPA has excluded the following five subcategories from limitations.

1. Primary Boron
2. Primary Cesium and Rubidium
3. Primary Lithium
4. Primary Magnesium
5. Secondary Zinc

Effluent BPT limitations were promulgated for the following 18 subcategories in 1985:

1. Primary Tungsten
2. Primary Columbium-Tantalum
3. Secondary Silver
4. Secondary Lead
5. Primary Antimony
6. Primary Beryllium
7. Primary and Secondary Germanium and Gallium
8. Primary Molybdenum and Rhenium
9. Secondary Molybdenum and Vanadium
10. Primary Nickel and Cobalt
11. Primary Precious Metals and Mercury
12. Secondary Precious Metals
13. Secondary Tantalum
14. Secondary Tin
15. Primary and Secondary Titanium
16. Secondary Tungsten and Cobalt
17. Secondary Uranium
18. Primary Zirconium and Hafnium

Briefly discussed below are descriptions of the options selected for each of these 18 subcategories. A discussion of primary lead and secondary aluminum BPT option selection will also be presented since limitations for these subcategories were modified. The mass limitations developed for these subcategories are presented in Section II of this document and the corresponding supplements. Table IX-2 (page 386) presents the pollutants selected for limitation in each of the subcategories.

PRIMARY LEAD

The technology basis for the BPT limitations is lime precipitation and sedimentation technology to remove metals and solids from combined wastewaters and to control pH. This technology is demonstrated at two primary lead smelters and will remove an estimated 4,286 kg/yr of toxic metals from the estimated raw discharge. Removal of TSS from raw discharge is estimated at 261,130 kg/yr. The capital and annual costs for achieving BPT are estimated at \$0.24 million (March 1982 dollars) and \$0.11 million, respectively.

PRIMARY TUNGSTEN

The technology basis for the BPT limitations is lime precipitation and sedimentation technology to remove metals and solids from combined wastewaters and to control pH, and ammonia steam stripping to remove ammonia. Lime and settle technology is already in place at three direct dischargers for this subcategory. Ammonia steam stripping is used by one direct discharger.

Implementation of the promulgated BPT limitations will result in the removal of 5,350 kg/yr of toxic metals from raw discharge estimates. Removal estimates from raw discharge for ammonia is 141,000 kg/yr and 50,300 kg/yr of TSS. The capital and annual costs for achieving BPT are estimated at \$0.62 million (March

1982 dollars) and \$1.0 million, respectively.

PRIMARY COLUMBIUM-TANTALUM

The technology basis for BPT effluent mass limitations is lime precipitation and sedimentation to control toxic metals, TSS, pH and fluoride, and ammonia steam stripping. Lime and settle technology is currently in place at all three direct dischargers. Ammonia steam stripping is currently used at two of the three direct discharging facilities.

Application of BPT treatment will result in the removal of 61,000 kg/yr of toxic pollutants, 1,692,000 kg/yr of conventional pollutants, and 941,000 kg/yr of ammonia from raw discharge estimates. The estimated capital investment cost of BPT is \$0.680 million (March 1982 dollars) and the estimated annual cost is \$1.14 million. These costs represent wastewater treatment not currently in place.

SECONDARY SILVER

The technology basis for BPT effluent mass limitations is lime precipitation and sedimentation to remove toxic metals and TSS and to control pH. Ammonia steam stripping is applied as pretreatment for removal of ammonia. Lime and settle treatment is currently in place at five direct dischargers, while ammonia steam stripping is transferred from the columbium-tantalum and tungsten subcategories.

The promulgated BPT will result in the removal of 30,900 kg/yr of toxic pollutants and 664,000 kg/yr of ammonia from estimated raw discharge levels. The estimated capital investment cost of BPT is \$0.11 million (March 1982 dollars) and the estimated annual cost is \$0.31 million. These costs represent wastewater treatment equipment not currently in place.

SECONDARY LEAD

The technology basis for BPT effluent mass limitations for the secondary lead subcategory is lime precipitation and sedimentation to control toxic metals, pH, and TSS. This technology is currently in place at five discharging facilities in the secondary lead subcategory.

The promulgated BPT will result in the removal of 25,350 kg/yr of toxic pollutants and 2,852,000 kg/yr of conventional pollutants from estimated raw discharge levels. The estimated capital investment cost of BPT is \$1.6 million (March 1982 dollars) and the estimated annual cost is \$0.684 million. These costs represent wastewater treatment equipment not currently in place.

PRIMARY ANTIMONY

The technology basis for the BPT limitations is lime

precipitation and sedimentation technology to remove metals and solids from combined wastewaters and to control pH and sulfide precipitation preliminary treatment. Lime and settle technology is in place at the one discharger in this subcategory. Sulfide precipitation is necessary to ensure that large amounts of arsenic present in the raw wastes are removed to the desired level.

Implementation of the BPT limitations will remove annually an estimated 17,522 kg of priority metals and 26,156 kg of pollutants including TSS from the current discharge. We project a capital cost of approximately \$196,350 and an annualized cost of approximately \$554,180 for achieving BPT.

More stringent technology options were not selected for BPT since they require in-process changes or end-of-pipe technologies less widely practiced in the subcategory, and, therefore, are more appropriately considered under BAT.

PRIMARY BERYLLIUM

The technology basis for the BPT limitations is chemical precipitation and sedimentation technology to remove metals and solids from combined wastewaters and to control pH and fluoride along with scrubber liquor recycle, and cyanide precipitation and ammonia steam stripping preliminary treatment. Lime and settle technology is already in place at the one discharger in the subcategory.

Implementation of BPT limitations will remove an estimated 2,698 kg/yr of priority metal pollutants and cyanide, 69,943 kg/yr of ammonia, and 131,734 kg/yr of pollutants including TSS from the raw wastewater. We project \$226,500 in capital costs and \$211,200 in annual costs for achieving promulgated BPT.

PRIMARY AND SECONDARY GERMANIUM AND GALLIUM

The technology basis for the BPT limitations is chemical precipitation and sedimentation technology to remove metals, fluoride, and solids from combined wastewaters and to control pH. The pollutants specifically included for regulation at BPT are arsenic, lead, zinc, fluoride, TSS, and pH.

Although there are no existing direct dischargers in this subcategory, BPT is promulgated for any existing zero discharger that elects to discharge at some point in the future. This action is necessary because wastewaters from germanium and gallium operations which contain significant loadings of priority pollutants are currently being disposed of in a RCRA - permitted surface impoundment.

More stringent technology options were not selected for BPT since they require in-process changes or end-of-pipe technologies less widely practiced in the subcategory, and, therefore, are more appropriately considered under BAT.

The cost and specific removal data for this subcategory are not presented here because the data on which they are based have been claimed to be confidential.

PRIMARY MOLYBDENUM AND RHENIUM

The technology basis for the BPT limitations is chemical precipitation and sedimentation technology to remove metals and solids from combined wastewaters and to control pH, and ammonia steam stripping and iron co-precipitation preliminary treatment. All to these technologies except iron co-precipitation are already in-place at one to the two dischargers in the subcategory.

Implementation of the BPT limitations will remove annually an estimated 73,644 kg to priority metals, 737 kg of molybdenum, 63,443 kg of ammonia, and 51,529 kg of TSS from the current discharge. While one discharging plant has the equipment in place to comply with BPT, we do not believe that plant is currently achieving the BPT mass limitations. The cost data for this subcategory are not presented here because the data on which they are based have been claimed to be confidential.

More stringent technology options were not selected for BPT since they require in-process changes or end-of-pipe technologies less widely practiced in the subcategory, and, therefore, are more appropriately considered under BAT.

SECONDARY MOLYBDENUM AND VANADIUM

The technology basis for the BPT limitations is iron co-precipitation, chemical precipitation and sedimentation technology to remove metals and solids from combined wastewaters and to control pH, and air stripping to remove ammonia. Except for iron co-precipitation, these technologies are already in place at the one discharger in the subcategory.

Implementation of the BPT limitations will remove annually an estimated 319 kg of priority metals and cyanide, 18,477 kg of molybdenum, 563,160 kg of ammonia, and 28,136 kg of TSS from the raw waste load. Although the one discharging facility in this subcategory has some of the technology in place to comply with BPT, we do not believe that the plant is currently achieving the BPT mass limitations. The cost data for this subcategory are not presented here because the data on which they are based have been claimed to be confidential.

More stringent technology options were not selected for BPT since they require in-process changes or end-of-pipe technologies not practiced at the one plant in the subcategory. These technologies must, therefore, be transferred from other subcategories where the technologies have been defined as BAT rather than BPT.

PRIMARY NICKEL AND COBALT

The technology basis for the BPT limitations is chemical precipitation and sedimentation technology to remove metals and solids from combined wastewaters and to control pH, and ammonia steam stripping to remove ammonia. Chemical precipitation and sedimentation technology is already in place at the one discharger in the subcategory.

Implementation of the BPT limitations will remove annually an estimated 241 kg of priority metals and 252 kg of total pollutants from the current discharge. While the one discharging plant has the equipment in place to comply with BPT, we do not believe that the plant is currently achieving the BPT mass limitations. The cost data for this subcategory are not presented here because the data on which they are based have been claimed to be confidential.

More stringent technology options were not selected for BPT since they require in-process changes or end-of-pipe technologies not practiced at the one plant in the subcategory. These technologies must, therefore, be transferred from other subcategories where the technologies have been defined as BAT rather than BPT.

PRIMARY PRECIOUS METALS AND MERCURY

The technology basis for the BPT limitations is chemical precipitation, sedimentation and ion exchange technology to remove metals and solids from combined wastewaters and to control pH, and oil skimming to remove oil and grease. Lime and settle technology is in place at the one discharger in this subcategory.

Implementation of the BPT limitations will remove annually an estimated 50,442 kg of priority metals and 53,768 kg of total pollutants including TSS from the raw waste load. We project a capital cost of \$2,200 and an annualized cost of \$26,814 for achieving proposed BPT limitations.

More stringent technology options were not selected for BPT since they require in-process changes or end-of-pipe technologies less widely practiced in the subcategory, and, therefore, are more appropriately considered under BAT.

SECONDARY PRECIOUS METALS

The technology basis for the BPT limitations is chemical precipitation, sedimentation and ion exchange technology to remove metals and solids from combined wastewaters and to control pH, ammonia steam stripping pretreatment to remove ammonia, and cyanide precipitation pretreatment to remove free and complexed cyanide. Chemical precipitation and sedimentation technology is already in place at 20 of the dischargers in the subcategory. One plant has cyanide precipitation in place. Although ammonia steam stripping is not currently practiced by

any of the plants in this subcategory, air stripping is practiced at one plant and steam stripping is demonstrated at plants in other nonferrous metals manufacturing subcategories.

Some of the plants in this subcategory have unusually high zinc levels. For those plants, costs were developed for two-stage precipitation using sulfide polishing as the second stage. Sulfide controls zinc to the desired levels and helps overcome complexation problems. Sulfide costs were included in the economic impact analysis.

Implementation of the BPT limitations will remove annually an estimated 94 kg of priority pollutants (which include 63 kg of cyanide), and 4,677 of total pollutants, which include 494 kg of ammonia, and 2,946 kg of TSS from the current discharge. The cost and specific removal data for this subcategory are not presented here because the data on which they are based have been claimed to be confidential.

More stringent technology options were not selected for BPT since they require in-process changes or end-of-pipe technologies less widely practiced in the subcategory, and, therefore, are more appropriately considered under BAT.

PRIMARY RARE EARTH METALS

EPA has withdrawn the BPT limitations that were promulgated for the Primary Rare Earth Metals Subcategory on September 20, 1985. These limitations were withdrawn because EPA failed to adequately address the sole direct discharging plant's comments in the Administrative Record. Therefore, national BPT limitations are not available for this subcategory, and applicable plant's effluent limitations will need to be developed by the local permitting authority through the NPDES program.

SECONDARY TANTALUM

The technology basis for the BPT limitations is chemical precipitation and sedimentation technology to remove metals and solids from combined wastewaters and to control pH. These technologies are already in place at three dischargers in the subcategory.

Implementation of the BPT limitations will remove annually an estimated 26,268 kg of priority metals, 1,490 kg of tantalum, and 51,392 kg of total pollutants including TSS from the current discharge. The cost and specific removal data for this subcategory are not presented here because the data on which they are based have been claimed to be confidential.

More stringent technology options were not selected for BPT since they require in-process changes or end-of-pipe technologies not practiced by any of the three existing plants in the subcategory. These technologies must, therefore, be transferred from other subcategories where the technologies have been defined as BAT

rather than BPT.

SECONDARY TIN

The technology basis for the BPT limitations is chemical precipitation and sedimentation technology to remove metals, fluoride, and solids from combined wastewaters and to control pH, with preliminary treatment consisting of cyanide precipitation for certain building blocks. Chemical precipitation and sedimentation technology is already in place at two of the three direct dischargers in the subcategory.

Implementation of the BPT limitations will remove annually from raw discharge an estimated 688 kg of priority metals, 144 kg of cyanide, 237,220 kg of fluoride, and 506,900 kg of TSS, for a total pollutant removal of 800,967 kg. Projected capital costs are estimated to be approximately \$841,285 while annual costs are estimated to be \$692,625. The Agency has determined that the pollutant reduction benefits associated with compliance justify the costs for this subcategory.

More stringent technology options were not selected for BPT since they require in-process changes or end-of-pipe technologies less widely practiced in the subcategory, and, therefore, are more appropriately considered under BAT.

PRIMARY AND SECONDARY TITANIUM

The technology basis for the BPT limitations is chemical precipitation and sedimentation technology to remove metals and solids from combined wastewaters and to control pH, and oil skimming preliminary treatment for streams with treatable concentrations of oil and grease. These technologies are already in place at two of the four direct dischargers in the subcategory. The pollutants specifically regulated at BPT are chromium, lead, nickel, titanium, oil and grease, TSS, and pH. We have exempted from regulation facilities which do not practice electrolytic recovery of magnesium and which use vacuum distillation instead of leaching to purify titanium sponge. We are promulgating these regulations for all other titanium plants and the two-tiered regulation as proposed is not promulgated.

Implementation of the BPT limitations will remove annually an estimated 217 kg of priority metals, 5,791 kg of titanium, and 64,446 kg of TSS from the raw waste load. While two plants have the equipment in place to comply with BPT, we do not believe that the plants are currently achieving the BPT limitations. We project a capital cost of \$644,500 and annualized cost of \$505,300 for achieving the BPT limitations.

More stringent technology options were not selected for BPT since they require in-process changes or end-of-pipe technologies less widely practiced in the subcategory, and, therefore, are more appropriately considered under BAT.

SECONDARY TUNGSTEN AND COBALT

The technology basis for the BPT limitations is chemical precipitation and sedimentation technology to remove metals and solids from combined wastewaters and to control pH, ammonia steam stripping to remove ammonia and oil skimming to remove oil and grease. Chemical precipitation and sedimentation technology is already in place at three direct dischargers in the subcategory.

Implementation of the BPT limitations will remove annually an estimated 150,600 kg of priority metals, 108,700 kg of TSS, and 420,200 of total pollutants from the current discharge. The cost and specific removal data for this subcategory are not presented here because the data on which they are based have been claimed to be confidential.

More stringent technology options were not selected for BPT since they require in-process changes or end-of-pipe technologies less widely practiced in the subcategory, and, therefore, are more appropriately considered under BAT.

SECONDARY URANIUM

The technology basis for the BPT limitations is chemical precipitation and sedimentation technology to remove metals and solids from combined wastewaters and to control pH. Chemical precipitation and sedimentation technology is already in place at the one discharger in the subcategory.

Implementation of the BPT limitations will remove annually an estimated 100 kg of priority metals and 5,034 kg of total pollutants including 651 kg of TSS from the estimated raw waste load. While the one discharging plant has the equipment in place to comply with BPT, we do not believe that the plant is currently achieving the BPT limitations. We project capital and annual costs of \$54,800 and \$90,400 (1982 dollars), respectively, for modifications to technology presently in-place at the discharging facility to achieve BPT regulations.

More stringent technology options were not selected for BPT since they require in-process changes or end-of-pipe technologies not practiced by any of the plants in the subcategory. These technologies must, therefore, be transferred from other subcategories where the technologies have been defined as BAT rather than BPT.

PRIMARY ZIRCONIUM AND HAFNIUM

The technology basis for the BPT limitations is recycle of scrubber liquors, chemical precipitation and sedimentation technology to remove metals and solids from combined wastewaters and to control pH, plus ammonia steam stripping and cyanide precipitation preliminary treatment to streams containing ammonia

and cyanide. Chemical precipitation and sedimentation technology and ammonia steam stripping is already in-place at one discharger in the subcategory. The pollutants specifically regulated at BPT are chromium, cyanide, lead, nickel, ammonia, TSS, and pH. We are now exempting from national regulation facilities which only produce zirconium or zirconium-nickel alloys by magnesium reduction of ZrO_2 . These BPT limitations apply to all other zirconium-hafnium facilities.

Implementation of the BPT limitations will remove annually an estimated 14,110 kg of priority metals and cyanide, and 19.4 million kg of pollutants including 38,240 kg of TSS from the raw waste load. The cost data for this subcategory are not presented here because the data on which they are based have been claimed to be confidential.

More stringent technology options were not selected for BPT since they require in-process changes or end-of-pipe technologies less widely practiced in the subcategory, and, therefore, are more appropriately considered under BAT.

THE BUILDING BLOCK APPROACH IN DEVELOPING PERMITS

A plant is to receive a discharge allowance for a particular building block only if it is actually operating that particular process. In this way, the building block approach recognizes and accommodates the fact that not all plants use identical steps in manufacturing a given metal. However, the plant need not be discharging wastewater from the process to receive the allowance. Thus, for example, if the regulation contains a discharge allowance for wet scrubber effluent and a particular plant has dry scrubbers, it cannot include a discharge allowance for wet scrubbers as part of its aggregate limitation. On the other hand, if it has wet scrubbers and discharges less than the allowable limit or does not discharge from the scrubbers, it would receive the full regulatory allowance in developing the permit.

There are several facilities within this category that have integrated manufacturing operations; that is, they combine wastewater from smelting and refining operations which are part of this point source category, with wastewater from other manufacturing operations which are not a part of this category, and treat the combined stream prior to discharge. For direct dischargers, this problem would be approached using the building block approach and developing discharge allowances for the additional wastewater streams from other applicable effluent limitations and standards or, if such are not available, using best professional judgment (BPJ). For indirect dischargers, this problem would be approached by determining the discharge allowances for the nonferrous metals manufacturing segment and applying the combined waste formula to determine the discharge allowance for the entire wastewater stream being treated. The combined wastewater formula is presented in 40 CFR 403 and is specifically intended to apply to those situations where

wastewaters from various categories or non categorical wastewaters are comingled before treatment and discharge.

Additional discussion of the development of discharge allowances from the mixed wastewaters within this category is presented at the end of Section X.

A summary of the BPT limitations (and also BAT, NSPS, PSES and PSNS) is presented in Section II of each supplement. Additionally, in each supplement, a table is presented for BPT (also for BAT, NSPS, PSES and PSNS) showing the levels at which all of the pollutants found at treatable levels would have been regulated if the Agency had deemed it necessary or appropriate to directly limit all of these pollutants. This additional information is presented so it may be used by permit writers as the Agency's best professional judgment whenever it becomes necessary or desirable to set limitations on the additional pollutants.

TABLE IX-1

SUMMARY OF CURRENT TREATMENT PRACTICES

Subcategory	Lime and Settle 1	Lime, Settle and Filter	Oil Skimming	Ammonia Stripping		Cyanide Treatment		Ion Exchange	Discharge Status			Total
				Air	Steam	Oxidation	Precipitation		Direct	Indirect	Zero	
Pri Aluminum Smelting	11 (1) 2 1 (0) 24 7 31											
Sec Aluminum Smelting	2 (1)	0 (0)							10	14	23	47
Pri Copper Smelting	3 (3)	0 (0)							2		18	20
Pri Electro- lytic Copper Refining	5 (3)	0 (0)	1 (1)						4		11	14
Sec Copper	5 (3)	2 (1)							5	6	20	31
Pri Lead	2 (0)	1 (0)							4	2	0	6
Sec Lead	26 (4)	2 (1)							8	26	15	49
Pri Zinc	4 (0)	1 (0)							3	1	4	8
Sec Silver	13 (0)	2 (0)							7	26	28	61
Pri Columbium and Tantalum	3 (0)	0 (0)			2 (0)				3	2		5
Pri Tungsten	4 (0)	0 (0)			3 (1)				4	6	6	16
Metallurgical Acid Plants	11 (1)	2 (0)							8	2	9	19
Pri Antimony	1								1		6	7
Bauxite Refin- ing									3		5	8
Pri Beryllium	1								1		2	3

TABLE IX-1 (Continued)
SUMMARY OF CURRENT TREATMENT PRACTICES

Subcategory	Lime and Settle 1	Lime, Settle and Filter	Oil Skimming	Ammonia Stripping		Cyanide Treatment		Ion Exchange	Discharge Status			Total
				Air	Steam	Oxidation	Precipitation		Direct	Indirect	Zero	
Pri Boron											2	2
Pri Cesium & Rubidium											1	1
Pri and Sec Germanium and Gallium										1	4	5
Sec Indium	1									1		1
Sec Mercury											4	
Pri Molybdenum and Rhenium	3 (1)				1				4		9	13
Sec Molybdenum and Vanadium	1			1					1			1
Pri Nickel and Cobalt	1	1							1			1
Sec Nickel	1 (1)									1	1	2
Pri Precious Mtls & Mercury	1								1		7	8
Sec Precious Metals	20	1		1		7 (1)	1	3	4	30	15	49
Pri Rare Earth Metals	1								1	1	2	4
Sec Tantalum	3								3			3

384

TABLE IX-1 (Continued)
 SUMMARY OF CURRENT TREATMENT PRACTICES

Subcategory	Lime and Settle 1	Lime, Settle and Filter	Oil Skimming	Ammonia Stripping		Cyanide Treatment		Ion Exchange	Discharge Status			Total
				Air	Steam	Oxidation	Precipitation		Direct	Indirect	Zero	
Sec Tin	2					1			3	2	7	12
Pri and Sec Titanium	2								4	2	2	8
Sec Tungsten and Cobalt	3				1				4	1	1	6
Sec Uranium	1								1		2	3
Pri Zirconium and Hafnium	2				1				1	1	1	3
Totals	133	13	1	3	8	8	1	3	115	125	211	451

NOTES:

1 The numbers in this column include plants tallied in the lime, settle and filter column.

2 Numbers in parentheses indicate zero dischargers with treatment.

Pri = primary

Sec = secondary

Table IX-2

BPT REGULATED POLLUTANT PARAMETERS

<u>Subcategory</u>	<u>Pollutant Parameters</u>
Primary Lead	122. lead 128. zinc TSS pH
Primary Tungsten	122. lead 128. zinc ammonia (N) TSS pH
Primary Columbium-Tantalum	122. lead 128. zinc ammonia (N) fluoride TSS pH
Secondary Silver	120. copper 128. zinc ammonia (N) TSS pH
Secondary Lead	114. antimony 115. arsenic 122. lead 128. zinc ammonia (N) TSS pH
Primary Antimony	114. antimony 115. arsenic 123. mercury TSS pH
Primary Beryllium	117. beryllium 119. chromium (total) 120. copper 121. cyanide ammonia (as N) fluoride TSS pH

Table IX-2 (Continued)

BPT REGULATED POLLUTANT PARAMETERS

<u>Subcategory</u>	<u>Pollutant</u>	<u>Parameters</u>	
Primary and Secondary Germanium and Gallium	115.	arsenic	
	122.	lead	
	128.	zinc	
		fluoride TSS pH	
Primary Molybdenum and Rhenium	115.	arsenic	
	122.	lead	
	124.	nickel	
	125.	selenium fluoride molybdenum ammonia (as N) TSS pH	
Secondary Molybdenum and Vanadium	115.	arsenic	
	119.	chromium	
	122.	lead	
	124.	nickel molybdenum ammonia (as N) iron TSS pH	
Primary Nickel and Cobalt	120.	copper	
	124.	nickel cobalt ammonia (as N) TSS pH	
Primary Precious Metals and Mercury	122.	lead	
	123.	mercury	
	126.	silver	
	128.	zinc gold oil and grease TSS pH	

Table IX-2 (Continued)

BPT REGULATED POLLUTANT PARAMETERS

<u>Subcategory</u>	<u>Pollutant Parameters</u>
Secondary Precious Metals	120. copper 121. cyanide 128. zinc ammonia (as N) gold palladium platinum TSS pH
Primary Rare Earth Metals	119. chromium (Total) 122. lead 124. nickel TSS pH
Secondary Tantalum	120. copper 122. lead 124. nickel 128. zinc tantalum TSS pH
Secondary Tin	115. arsenic 121. cyanide 122. lead iron tin fluoride TSS pH
Primary and Secondary Titanium	119. chromium (total) 122. lead 124. nickel titanium oil and grease TSS pH

Table IX-2 (Continued)

BPT REGULATED POLLUTANT PARAMETERS

<u>Subcategory</u>	<u>Pollutant Parameters</u>
Secondary Tungsten and Cobalt	120. copper 124. nickel cobalt tungsten oil and grease ammonia (as N) TSS pH
Secondary Uranium	119. chromium (total) 120. copper 124. nickel fluoride TSS pH
Primary Zirconium and Hafnium	119. chromium (total) 121. cyanide (total) 122. lead 124. nickel ammonia (as N) TSS pH

THIS PAGE INTENTIONALLY LEFT BLANK

SECTION X

EFFLUENT QUALITY ATTAINABLE THROUGH APPLICATION OF
THE BEST AVAILABLE TECHNOLOGY ECONOMICALLY ACHIEVABLE

This section sets forth the effluent limitations attainable through the application of best available technology economically achievable (BAT). It also serves to summarize changes from previous rulemakings in the nonferrous metals manufacturing category, and presents the development and use of the mass-based effluent limitations.

A number of factors guide the BAT analysis including the age of equipment and facilities involved, the processes employed, process changes, non-water quality environmental impacts (including energy requirements), and the costs of application of such technology. BAT technology represents the best available technology economically achievable at plants of various ages, sizes, processes, or other characteristics. BAT may include process changes or internal controls, even when these are not common industry practice. This level of technology also considers those plant processes and control and treatment technologies which, at pilot plant and other levels, have demonstrated both technological performance and economic viability at a level sufficient to justify investigation.

The required assessment of BAT "considers" costs, but does not require a balancing of costs against effluent reduction benefits (see Weyerhaeuser v. Costle, 11 ERC 2149 (D.C. Cir. 1978)). In developing the proposed and promulgated BAT, however, EPA has given substantial weight to the economic achievability of the technology. The Agency has considered the volume and nature of discharges expected after application of BAT, the general environmental effects of the pollutants, and the costs and economic impacts of the required pollution control levels.

The BAT effluent limitations are organized by subcategory for individual sources of wastewater. The limitations were developed based on the attainable effluent concentrations and production normalized flows that have been presented in this document. Implementation of the BAT effluent limitations is expected to remove 1,968,000 kg/yr of priority pollutants from current discharge. The estimated capital cost of BAT is \$28.4 million (1982 dollars), and the estimated annual cost is \$22.7 million (1982 dollars).

TECHNICAL APPROACH TO BAT

In the past, the technical approach for the nonferrous metals manufacturing category considered each plant as a single wastewater source, without specific regard to the different unit processes that are used in plants within the same subcategory. For this rulemaking, end-of-pipe treatment technologies and in-process controls were examined in the selection of the best

available technology. After examining in-process controls, it became apparent that it was best to establish effluent limitations and standards recognizing specific wastewater streams associated with specific manufacturing operations. The approach adopted for this rule considers the individual wastewater sources within a plant, resulting in more effective pollution abatement by tailoring the regulation to reflect these various wastewater sources. This approach, known as the building block approach, was presented in Section IX. Another example to this approach is given at the end of this section.

INDUSTRY COST AND POLLUTANT REDUCTION BENEFITS OF THE VARIOUS TREATMENT OPTIONS

Under these guidelines, four treatment options were evaluated in selection of BAT for the category. Because of the diverse processes and raw materials used in the nonferrous category, the pollutant parameters found in various waste streams are not uniform. This required the identification of significant pollutants in the various waste streams so that appropriate treatment technologies could be selected for further evaluation. The options considered applicable to the nonferrous metals manufacturing subcategories are presented in Table X-1 (page). A thorough discussion of the treatment technologies considered applicable to wastewaters from the nonferrous metals manufacturing category is presented in Section VII of this document. In Section VII, the attainable effluent concentrations of each technology are presented along with their uniform applicability to all subcategories. Mass limitations developed from these options may vary, however, because of the impact of different production normalized wastewater discharge flows.

In summary, the treatment technologies considered for nonferrous metals manufacturing are:

Option A is based on:

Chemical precipitation of metals followed by sedimentation, and, where required, cyanide precipitation, sulfide precipitation, iron co-precipitation, ammonia air or steam stripping and oil skimming pretreatment, with ion-exchange end-of-pipe treatment.

(This option is equivalent to the technology on which BPT is based.)

Option B is based on:

Option A (chemical precipitation and sedimentation with cyanide precipitation, sulfide precipitation, iron co-precipitation, ammonia air or steam stripping, and oil skimming pretreatment, with ion exchange end-of-pipe treatment where needed) plus process wastewater flow reduction by the following methods:

- Contact cooling water recycle through cooling towers.
- Holding tanks for all other process wastewater subject

to recycle.

Option C is based on:

Option B (chemical precipitation and sedimentation with cyanide precipitation, sulfide precipitation, iron co-precipitation, ammonia air or steam stripping, and oil skimming pretreatment, with ion exchange end-of-pipe treatment where needed, preceded by in-process flow reduction), plus multimedia filtration.

Option E is based on:

Option C (chemical precipitation, sedimentation with cyanide precipitation, sulfide precipitation, iron co-precipitation, ammonia air or steam stripping, and oil skimming pretreatment, with ion exchange end-of-pipe treatment where needed, in-process flow reduction, and multimedia filtration), plus activated carbon adsorption applied to the total plant discharge as a polishing step.

Two additional technologies, activated alumina and reverse osmosis, were evaluated for this category. Activated alumina treatment was included for reduction of fluoride and arsenic concentrations. Reverse osmosis was considered so that complete recycle of all process wastewater could be attained. However, both of these technologies were rejected because they are not demonstrated in the nonferrous metals manufacturing category, nor are they clearly transferable. These two technologies are discussed in greater detail in Section VII of this document.

As a means of evaluating the economic achievability of each of these treatment options, the Agency developed estimates of the compliance costs and pollutant reduction benefits. An estimate of capital and annual costs for the applicable BAT options was prepared for each subcategory as an aid in choosing the best BAT option. The cost estimates are presented in Section X of each of the subcategory supplements. All costs are based on March 1982 dollars.

The cost methodology has been described in detail in Section VIII. For most treatment technologies, standard cost literature sources were used for module capital and annual costs. Data from several sources were combined to yield average or typical costs as a function of flow or other characteristic design parameters. In a small number of modules, the technical literature was reviewed to identify the key design criteria, which were then used as a basis for vendor contacts. The resulting costs for individual pieces of equipment were combined to yield module costs. In all cases, the cost data were coupled with flow data from each plant to establish system costs for each facility.

The estimated pollutant removal that the treatment technologies can achieve for each option for each subcategory is presented in Section X of each of the subcategory supplements.

The first step in the calculation of the removal estimates is the calculation of production normalized raw waste values (mg/kkg) for each pollutant in each waste stream. The raw waste values were calculated using one of three methods. When analytical concentration data (mg/l) and sampled production normalized flow values (l/kkg) were available for a given waste stream, individual raw waste values for each sample were calculated and averaged. This method allows for the retention of any relationship between concentration, flow and production. When sampled production normalized flows were not available for a given waste stream, an average concentration was calculated for each pollutant, and the average production normalized flow taken from the dcp information for that waste stream was used to calculate the raw waste. When analytical values were not available for a given waste stream, the raw waste values for a stream of similar water quality was used.

The total flow (l/yr) for each option for each subcategory was calculated by the following three steps: first, comparing the actual discharge to the regulatory flow for each waste stream; second, selecting the smaller of the two values; and third, summing the smaller flow values for each waste stream in the subcategory for each option. The regulatory flow values were calculated by multiplying the total production associated with each waste stream in each subcategory (kkg/yr) by the appropriate production normalized flow (l/kkg) for each waste stream for each option.

The raw waste mass values (kg/yr) for each pollutant in each subcategory were calculated by summing individual raw waste masses for each waste stream in the subcategory. The individual raw waste mass values were calculated by multiplying the total production associated with each waste stream in each subcategory (kkg/yr) by the raw waste value (mg/kkg) for each pollutant in each waste stream.

The mass discharged (kg/yr) for each pollutant for each option for each subcategory was calculated by multiplying the total flow (l/yr) for those waste streams which enter the central pretreatment system, by the treatment effectiveness concentration (mg/l) (Table VII-21 page xxx) for each pollutant for the appropriate option.

The total mass removed (kg/yr) for each pollutant for each option for each subcategory was calculated by subtracting the total mass discharged (kg/yr) from the total raw mass (kg/yr).

Total treatment performance values for each subcategory were calculated by using the total production (kkg/yr) of all plants in the subcategory for each waste stream. Treatment performance values for direct dischargers in each subcategory were calculated by using the total production (kkg/yr) of all direct dischargers in the subcategory for each waste stream.

MODIFICATION OF EXISTING BAT EFFLUENT LIMITATIONS

Modifications were promulgated to all existing promulgated BAT effluent limitations in the nonferrous metals manufacturing category. In general, the existing BAT effluent limitations have been modified to incorporate the building block approach. A detailed discussion regarding the development of mass limitations from this approach is presented in Section IX. Other modifications to the primary lead subcategory, secondary aluminum subcategory, primary zinc subcategory, and metallurgical acid plants subcategory were made as a result of new information supplied to the Agency.

To reflect the changes in stormwater allowances promulgated for BPT in the primary copper smelting and secondary copper subcategories, the Agency is promulgating modifications to the stormwater allowances promulgated under BAT. The promulgated changes allow a discharge resulting from a catastrophic rainstorm, but they eliminate the monthly net precipitation discharge allowance. The building block approach is not developed for these two subcategories since they are required to maintain zero discharge of all process wastewater pollutants.

The technology basis for BAT has been modified, in most cases to be lime precipitation, sedimentation and filtration. Sulfide precipitation is also included as the technology basis for the primary lead, primary zinc, and metallurgical acid plants subcategories and for one primary copper plant. The Agency believes this represents the best available technology economically achievable.

Allowances for Net Precipitation in Bauxite Refining

Promulgated BPT and BAT limitations for the bauxite refining subcategory are based on the use of settling impoundments. Facilities in this subcategory are subject to a zero discharge requirement; however, during any month they can discharge a volume of water equal to the difference between precipitation that falls within the impoundment and evaporation from that impoundment for that month (net precipitation).

We are promulgating minor technical amendments to delete or correct references to FDF considerations under Part 125 and pretreatment references to Part 128. We are not altering the existing BAT (promulgated on April 8, 1974 under Subpart A to 40 CFR Part 421) which prohibits the discharge of process wastewater except for an allowance for net precipitation that falls within process wastewater impoundments.

Primary Aluminum Smelting

The previous BAT effluent limitations were developed by considering each plant as a single wastewater source and allocating one discharge rate from which the effluent limitations were calculated. The technology basis from which these effluent limitations were developed are lime and settle performance values. The modified BAT effluent limitations were developed for individual wastewater sources identified within the primary aluminum subcategory, and effluent concentrations attainable with lime precipitation, sedimentation, filtration, and cyanide precipitation. This technology is discussed in greater detail in the BAT option selection of this section.

Secondary Aluminum Smelting

The previously promulgated BAT for this subcategory prohibited the discharge of process wastewater. However, new information supports the need for discharge of wastewater from chlorine demagging, an operation considered and included in the promulgated zero discharge regulation. Three dry processes existed at the time of promulgation: the Durham process; the Alcoa process; and the Teller process. The Agency believed that each of these processes were sufficiently well demonstrated to be installed and become operational by 1984, the compliance date for BAT. Consequently, there was no justification for a discharge allowance associated with this waste stream.

New information shows that the technologies are not sufficiently demonstrated nor are they applicable to plants on a nationwide basis. For this reason, the promulgated BAT has been modified; the modified BAT is based on the use of wet scrubbing on chlorine demagging operations.

Information received through comments on the 1983 proposed regulation and through data requests shows a need for discharge of water from ingot conveyer casting. A discharge allowance will be provided, but is intended only for those plants that do not practice chlorine demagging wet air pollution control. Complete reuse of ingot conveyer casting contact cooling water in demagging wet air scrubber operations is demonstrated.

Comments and information received in response to dcp requests subsequent to the 1983 proposal also show the need for a discharge allowance for wet scrubbers used in delacquering operations, where paint and lacquers are burned from the surface of aluminum can scrap. The promulgated BAT effluent limitations include this waste stream, which was not considered nor included in the 1974 BAT regulation.

Primary Electrolytic Copper Refining

The previous BAT effluent limitations were developed by considering each plant as a single wastewater source and allocating one discharge rate from which the effluent limitations

were calculated. The technology basis was lime precipitation and sedimentation performance values. The modified BAT effluent limitations were developed for individual wastewater sources identified within the primary electrolytic copper refining subcategory, and effluent concentrations attainable with lime precipitation, sedimentation, in-process flow reduction, and multimedia filtration. This technology is discussed in greater detail in the BAT option selection of this section.

Primary Lead

With the exception of stormwater exemptions, the previous BAT effluent limitations required zero discharge of all process wastewater pollutants. Before proposing modified limitations in 1983, information supplied to the Agency showed that slag removed from the smelting furnace may contain recoverable concentrations of lead. For the smelter slag to be recycled back into the production process, it must be granulated so that it is compatible with concentrated ore. The Agency has determined that this waste stream requires a discharge to control the build-up of suspended solids.

However, in the final rule, EPA has moved the proposed flow allowance for blast furnace slag granulation to dross reverberatory slag granulation. The Agency changed this allowance so that a plant that achieves zero discharge of blast furnace slag granulation would not receive a discharge allowance that is not needed.

Primary Zinc

The previous BAT effluent limitations were developed from one wastewater discharge rate and lime and settle performance values. The modified BAT effluent limitations were developed for individual wastewater sources identified within the primary zinc subcategory, and effluent concentrations attainable with lime precipitation, sedimentation, sulfide precipitation (and sedimentation), in-process flow reduction, and multimedia filtration. This technology is discussed in greater detail in the BAT option selection of this section.

Metallurgical Acid Plants

As discussed in Section IX, the metallurgical acid plants subcategory has been modified to include acid plants associated with primary lead and zinc smelters, and primary molybdenum roasters. This is based on the similarity between discharge rates and effluent characteristics of wastewaters from all metallurgical acid plants. The Agency is also establishing effluent limitations for fluoride and molybdenum in discharges from acid plants associated with primary molybdenum operations. The existing BAT limitations are based on the BPT technology (lime precipitation and sedimentation), in-process wastewater reduction, with sulfide precipitation, iron co-precipitation preliminary treatment and filtration. Flow reductions are based

on 90 percent recycle of scrubber liquor.

Compliance with the BAT limitations for the metallurgical acid plants subcategory by the two direct discharging primary molybdenum facilities which operate sulfuric acid plants will result in the annual removal of an estimated 4,651 kg of priority pollutants which is 219 kg of priority pollutants greater than the estimated BPT removed and 67,539 kg of total pollutants including molybdenum.

The costs for this subcategory are not presented here because the data on which they are based have been claimed to be confidential. The Agency has determined that BAT limitations for this subcategory are technically feasible and economically achievable.

MODIFIED APPROACH TO STORMWATER

For the same reasons discussed in detail in Section IX, no allowance will be given for stormwater under BAT. Stormwater is or can be segregated from the process wastewater. Furthermore, stormwater is site-specific and is best addressed on a case-by-case basis by the permit writer. Should a sufficient number of plants demonstrate that segregation of stormwater would result in excessive costs or is not technically feasible, or demonstrate that contamination of stormwater with process pollutants is an unavoidable result of manufacturing processes, the Agency will consider modification of the promulgated regulation as appropriate.

The BAT regulations on catastrophic and net precipitation exemptions are modified for several subcategories. These changes are presented in Table X-2 (page xxx). The reasons for modifying the BAT relief provisions for primary copper smelting, primary copper electrolytic refining, secondary copper and primary lead are as follows:

1. The technology basis for BAT has been changed from wastewater impoundments to equipment such as holding tanks, cooling towers, and clarifiers. This type of equipment is not influenced to the same degree as cooling impoundments. As a result, storm relief is not necessary to treat process wastewater (with the exception noted in (2) below).
2. For primary copper smelting and secondary copper, impoundments to treat cooling water are used at many facilities as an alternative to cooling towers. EPA has thus provided that stormwater may be discharged from these impoundments when a 25-year, 24-hour storm or larger has been experienced by the facility. The volume of water that may be discharged is only that which falls directly on the impoundment surface. Further, since the size required for cooling water impoundments is substantially smaller than impoundments

that treat other process wastewaters, no net precipitation relief is necessary. The amount of freeboard available in the proper design and operation of these cooling water ponds is sufficient for most facilities to accommodate the fluctuations in volume resulting from the precipitation cycle without having to discharge.

BAT OPTION SELECTION

The option generally selected throughout the category is Option C - chemical precipitation, sedimentation, in-process flow reduction, and multimedia filtration, along with applicable pretreatment, including ammonia air or steam stripping, cyanide precipitation, sulfide precipitation, iron co-precipitation, and oil skimming pretreatment, and ion exchange end-of-pipe treatment. The Agency has selected BPT plus in-process wastewater flow reduction and the use of filtration as an effluent polishing step as BAT for all of the subcategories except secondary aluminum, which includes preliminary treatment of phenolics with activated carbon adsorption, where applicable, and primary and secondary germanium and gallium, where BAT is based on lime and settle.

This combination of treatment technologies has been selected because they are technically feasible and are demonstrated within the nonferrous metals manufacturing category. Implementation of this treatment scheme would result in the removal of an estimated 1,968,000 kg/yr of priority pollutants from current discharge estimates. Although the Agency is not required to balance the costs against effluent reduction benefits (see Weyerhaeuser v. Costle, supra), the Agency has given substantial weight to the reasonableness of cost. The Agency's current economic analysis shows that this combination of treatment technologies is economically achievable. Price increases are not expected to exceed 2.5 percent for any subcategory.

Of the 36 subcategories considered in nonferrous metals manufacturing, EPA has reserved setting BAT limitations for the following three subcategories:

1. Secondary Indium
2. Secondary Mercury
3. Secondary Nickel

As discussed earlier, EPA has excluded the following five subcategories from limitations under the provisions of Paragraph 8 of the Settlement Agreement:

1. Primary Boron
2. Primary Cesium and Rubidium
3. Primary Lithium
4. Primary Magnesium
5. Secondary Zinc

BAT Effluent limitations have been promulgated for the following 28 subcategories:

1. Bauxite Refining
2. Primary Aluminum Smelting
3. Secondary Aluminum Smelting
4. Primary Copper Smelting
5. Primary Electrolytic Copper Refining
6. Secondary Copper
7. Primary Lead
8. Primary Zinc
9. Metallurgical Acid Plants
10. Primary Tungsten
11. Primary Columbium-Tantalum
12. Secondary Silver
13. Secondary Lead
14. Primary Antimony
15. Primary Beryllium
16. Primary and Secondary Germanium and Gallium
17. Primary Molybdenum and Rhenium
18. Secondary Molybdenum and Vanadium
19. Primary Nickel and Cobalt
20. Primary Precious Metals and Mercury
21. Secondary Precious Metals
22. Primary Rare Earth Metals
23. Secondary Tantalum
24. Secondary Tin
25. Primary and Secondary Titanium
26. Secondary Tungsten and Cobalt
27. Secondary Uranium
28. Primary Zirconium and Hafnium

The general approach taken by the Agency for BAT regulation of this category and the BAT option selected for each subcategory is presented in this section. The actual limitations may be found in Section II of each subcategory supplement.

After publication of the nonferrous metals manufacturing regulations, some petitioners challenged the promulgated rule. EPA developed settlement agreements based on some of these petitions. The results of these settlement agreements are discussed in the pertinent subcategory supplements.

In the regulatory sections of each subcategory supplement, the pollutants considered for regulation are included in the regulatory tables for that subcategory. Only some of these pollutants were selected for regulation and the regulated pollutants are indicated with an asterisk in each table. The pollutants found at treatable levels but not regulated are presented to assist the permit writer by advising him of the discharge allowance that would have been assigned if these pollutants had been regulated.

Primary Aluminum Smelting

The BAT option selected is flow reduction, lime precipitation, sedimentation, and filtration for control of toxic metals and fluoride, and cyanide precipitation preliminary treatment.

This combination of treatment technologies was selected because it provides additional pollutant removal achievable by the primary aluminum subcategory and it is economically achievable. Lime precipitation and sedimentation are widely practiced at primary aluminum plants, and as indicated in the previous section, form the basis for the BPT limitations. Filtration serves as an important polishing step in BAT. For this subcategory, it results in the removal of 271,350 kg/yr of toxic pollutants and 5,231,000 kg/yr of nonconventional pollutants from the estimated raw discharge. Further, lime precipitation and sedimentation are demonstrated at 11 primary aluminum smelters, while filtration is demonstrated at 23 plants in the nonferrous metals manufacturing category including one plant in the primary aluminum subcategory. The estimated capital investment cost of BAT is \$16 million (1982 dollars) and the annual cost is \$10.5 million.

Cyanide precipitation preliminary treatment is directed at control of free and complexed cyanides in waste streams within the primary aluminum subcategory that result from use of coke and pitch in the electrolytic reduction process. These waste streams collectively discharge approximately 62,000 kg/yr of cyanide. The Agency conducted a pilot-scale treatment performance study for cyanide precipitation on wastewater from a cathode reprocessing operation, the only primary aluminum operation to generate cyanide. The treatment effectiveness concentration for cyanide achieved from this study is the basis for the mass limitation. The mean was also shown, in data submitted by a primary aluminum facility, to be achievable by ion exchange technology applied to cyanide-contaminated groundwater. In developing variability factors for cyanide precipitation technology, EPA will continue to use the mean variability from the combined metals data base because only two data points were generated by the treatability study.

Flow reduction is an important element of BAT because it results in reduced dilution of pollutants and smaller hydraulic flows, which in turn lead to more efficient treatment, smaller treatment systems, and an associated reduction in the net cost of treatment. Wastewater flow reduction is based on increased recycle of scrubber liquor from potline, potline SO₂ emissions, potroom, and anode bake scrubbers, in addition to casting contact cooling water.

Secondary Aluminum Smelting

The BAT effluent limitations for the secondary aluminum subcategory are based on lime precipitation, sedimentation, filtration, ammonia steam stripping, and activated carbon

adsorption. Ammonia steam stripping is selected by the Agency over air stripping because air stripping reduces ammonia concentrations by simply transferring pollutants from one media (water) to another (air). Steam stripping reduces ammonia concentrations by stripping the ammonia from wastewater with steam. The ammonia is concentrated in the steam phase and may be condensed, collected, and sold as a by-product or disposed off-site. Ammonia steam stripping is demonstrated by five facilities in the nonferrous metals manufacturing category. Filtration is not demonstrated in the secondary aluminum subcategory; however, it is demonstrated in the nonferrous metals manufacturing category.

Activated carbon adsorption preliminary treatment to remove 4-AAP phenols applies to plants discharging scrubber water from delacquering furnace operations (an operation that removes paint and other surface coatings from aluminum scrap).

Application of the promulgated BAT will result in the removal of 9,590 kg/yr of toxic pollutants, 526 kg/yr of phenols, and 90,300 kg/yr of aluminum from the estimated raw discharge. The estimated capital investment cost of the promulgated BAT is \$1.1 million (1982 dollars) and the estimated annual cost is \$0.64 million.

Primary Copper Electrolytic Refining

The BAT effluent limitations for Primary Copper Electrolytic Refining are based on in-process flow reduction and end-of-pipe treatment technology consisting of lime precipitation, sedimentation, and multimedia filtration. Sulfide precipitation is added for one integrated copper refiner and smelter based on the demonstrated inability of this plant to meet the arsenic mass limitations with lime and settle technology. The Agency believes that the mass limitations are achievable using sulfide precipitation based on bench-scale performance tests using the plant's wastewater. Filtration is not demonstrated in this subcategory, but it is transferred from the primary aluminum, secondary copper, primary zinc, primary lead, secondary lead, and secondary silver subcategories.

Application of the promulgated BAT will result in the removal of 48,700 kg/yr of toxic pollutants from the estimated raw discharge. The estimated capital investment cost of the promulgated BAT is \$2.7 million (1982 dollars) and the estimated annual cost is \$1.7 million.

Primary Lead

The effluent limitations for the primary lead subcategory are based on the existing BPT with additional reduction in pollutant discharge achieved through in-process wastewater flow reduction, sulfide precipitation technology, and the use of filtration as an effluent polishing step. Wastewater flow reduction is based on the complete recycle of process wastewater from zinc fuming wet

air pollution control, blast furnace slag granulation, and hard lead refining wet air pollution control. Extensive treatment performance data submitted to the Agency from a well-operated plant in this subcategory indicate that, for this facility, the proposed BAT mass limitations are not achievable with lime, settle and filter technology. The principal reason for not being able to attain the proposed effluent limits is the inability to achieve the combined metals data base lime, settle and filter concentration values. The specific technical factors in this failure could not be determined from the data submitted. However, the Agency believes the addition of sulfide precipitation, in conjunction with multimedia filtration, will achieve the treatment effectiveness values because of the lower solubility of metal sulfides (i.e., lower than metal hydroxides) as well as performance data for sulfide technology obtained from treating nonferrous metals and inorganic chemical wastewaters. Sulfide precipitation is currently demonstrated at a primary molybdenum plant with a metallurgical acid plant, and at a cadmium plant in the primary zinc subcategory. Filtration is currently demonstrated by one facility in the primary lead subcategory.

Application of the promulgated BAT will result in the removal of 734 kg/yr of toxic pollutants over the estimated BPT removal. The primary lead subcategory is estimated to incur a capital cost of \$0.2 million (1982 dollars) and an annual cost of \$0.11 million to implement the BAT technology.

Primary Zinc

The BAT effluent limitations for the primary zinc subcategory are based on BPT with additional reduction in pollutant discharge achieved through in-process wastewater flow reduction, sulfide precipitation technology, and the use of filtration as an effluent polishing step. Wastewater flow reduction is based on increased recycle of casting scrubber water and casting contact cooling water. As discussed above, sulfide precipitation and filtration is added to ensure achievability of the combined metals data base treatment effectiveness concentration values for lime, settle and filter technology. Sulfide precipitation is currently demonstrated at a cadmium plant in the primary zinc subcategory, and at a primary molybdenum plant with a metallurgical acid plant. Filtration is currently in place at one of the three direct discharging plants in the primary zinc subcategory.

Application of the promulgated BAT effluent mass limitations will result in the removal of 1,159,000 kg/yr of toxic pollutants from the estimated raw discharge. The estimated capital investment cost of the promulgated BAT is \$0.46 million (1982 dollars) and the estimated annual cost is \$0.24 million. Activated alumina and reverse osmosis were also considered for BAT but were rejected. These technologies are not demonstrated in the category, nor are they clearly transferable.

Metallurgical Acid Plants

The BAT effluent limitations for metallurgical acid plants are based on BPT with additional reduction in pollutant discharge achieved through in-process wastewater flow reduction, sulfide precipitation technology, and the use of filtration as an effluent polishing step. Wastewater flow reduction is based on increased recycle of acid plant scrubber liquor. As discussed above, sulfide precipitation and filtration is added to ensure achievability of the combined metals data base treatment effectiveness concentration values for lime, settle and filter technology. Sulfide precipitation is currently demonstrated at a cadmium plant in the primary zinc subcategory, and at a primary molybdenum plant with a metallurgical acid plant. Filtration is currently demonstrated at two of the seven direct discharging plants in the metallurgical acid plants subcategory.

Application of the promulgated BAT mass limitations will result in the removal of 136,800 kg/yr of toxic pollutants from the estimated raw discharge. The estimated capital investment cost of BAT is \$1.97 million (1982 dollars) and the annual cost is \$1.24 million.

Filtration, option C, was selected instead of option B because it is demonstrated and results in removal of 7,590 kg/yr of toxic pollutants.

Primary Tungsten

The BAT limitations for the primary tungsten subcategory are based on BPT with additional reduction in pollutant discharge achieved through in-process wastewater flow reduction and the use of filtration as an effluent polishing step. Wastewater flow reduction is based on 90 percent recycle of scrubber liquors. Filtration is currently demonstrated at 23 plants in the category.

Application of the promulgated BAT will remove an estimated 5,140 kg/yr of toxic pollutants, which is 318 kg/yr of toxic metals over the estimated BPT removal. No additional ammonia is removed at BAT, nor are any toxic organics removed. The estimated capital investment cost of BAT is \$0.77 million (1982 dollars) and the estimated annual cost is \$1.0 million.

Primary Columbium-Tantalum

The BAT limitations for the primary columbium-tantalum subcategory are based on BPT with additional reduction in pollutant discharge achieved through in-process wastewater flow reduction and the use of filtration as an effluent polishing step. Wastewater flow reduction is based on increased recycle of scrubber liquors associated with three sources: concentrate digestion scrubber, solvent extraction scrubber, and precipitation scrubber. Filtration is currently demonstrated at 23 nonferrous metals manufacturing plants.

Application of the promulgated BAT will result in the removal of 283 kg/yr of toxic pollutants and 1,980 kg/yr of nonconventional pollutants over the estimated BPT removal. The estimated capital investment cost of BAT is \$0.83 million (1982 dollars) and the estimated annual cost is \$1.2 million.

Filtration, option C, was selected instead of option B because it is demonstrated and results in removal of 57 kg/yr of toxic pollutants and 94 kg/yr of nonconventional pollutants.

Secondary Silver

The BAT limitations for the secondary silver subcategory are based on BPT with additional reduction in pollutant discharge through in-process wastewater flow reduction and the use of filtration as an effluent polishing step. Wastewater flow reduction is based on complete recycle of furnace scrubber water. Filtration is currently demonstrated at two of the seven direct discharging secondary silver plants.

Application of the promulgated BAT will result in the removal of 132 kg/yr of toxic pollutants over the estimated BPT removal. The estimated capital investment cost of the promulgated BAT is \$0.28 million (1982 dollars) and the annual cost is \$0.39 million.

Filtration, option C, was selected instead of option B because it is demonstrated and results in removal of 132 kg/yr of toxic pollutants.

Secondary Lead

The BAT limitations for the secondary lead subcategory are based on BPT with additional reduction in pollutant discharge through in-process wastewater flow reduction and the use of filtration as an effluent polishing step. Wastewater flow reduction is based on 90 percent recycle of casting contact cooling water and complete recycle of facility washdown water and battery case classification wastewater. Filtration is currently demonstrated at one of eight direct discharging secondary lead plants and seven plants in this subcategory.

Application of the promulgated BAT will result in the removal of 350 kg/yr of toxic pollutants over the estimated BPT removal. The estimated capital investment cost of this technology is \$1.86 million, (1982 dollars) and the estimated annual cost is \$1.24 million.

Primary Antimony

The BAT limitations for the primary antimony subcategory are based on chemical precipitation and sedimentation and sulfide precipitation preliminary treatment (BPT technology) with the

addition of filtration.

The pollutants specifically limited under BAT are antimony, arsenic, and mercury. The priority pollutants cadmium, copper, lead, and zinc were also considered for regulation because they were found at treatable concentrations in the raw wastewaters from this subcategory. These pollutants were not selected for specific regulation because they will be effectively controlled when the regulated priority metals are treated to the levels achievable by the model BAT technology.

Implementation of the BAT limitations would remove annually an estimated 18 kg of priority metals over the estimated BPT discharge. Estimated capital cost for achieving BAT is \$208,300, and annualized cost is \$560,400.

Primary Beryllium

The BAT limitations for the primary beryllium subcategory are based on chemical precipitation and sedimentation preceded by scrubber liquor recycle, ammonia steam stripping and cyanide precipitation (BPT technology), with the addition of filtration and scrubber water recycle. Flow reduction is based on greater than 90 percent recycle of beryllium oxide calcining furnace wet air pollution control. The one beryllium plant currently generating beryllium oxide calcining furnace wet air pollution control wastewater does practice recycle.

The pollutants specifically limited under BAT are beryllium, chromium, copper, cyanide, ammonia, and fluoride.

Implementation of the BAT limitations would remove annually an estimated 8 kg of priority metals and 0.5 kg of cyanide over the estimated BPT discharge. No additional ammonia is removed.

The costs and specific removal data for this subcategory are not presented here because the data on which they are based has been claimed to be confidential.

Primary and Secondary Germanium and Gallium

The BAT limitations for the primary and secondary germanium and gallium subcategory are based on chemical precipitation and sedimentation (BPT technology).

The pollutants specifically limited under BAT are arsenic, lead, zinc, and fluoride. The priority pollutants antimony, cadmium, chromium, copper, nickel, selenium, silver and thallium were also considered for regulation because they were found at treatable concentrations in the raw wastewaters from this subcategory. These pollutants were not selected for specific regulation because they will be effectively controlled when the regulated priority metals are treated to the concentrations achievable by the model BAT technology. EPA is including limitations for gallium and germanium as guidance for permitting authorities.

Although there are no existing direct dischargers in this subcategory, BAT is promulgated for any existing zero discharger who elects to discharge at some point in the future. This action was necessary because wastewaters from germanium and gallium operations which contain significant loadings of priority pollutants are currently being disposed of in a RCRA permitted surface impoundment.

The costs and specific removal data for this subcategory are not presented here because the data on which they are based has been claimed to be confidential.

Primary Molybdenum and Rhenium

The BAT limitations for the primary molybdenum and rhenium subcategory are based on preliminary treatment consisting to ammonia steam stripping, iron co-precipitation, and end-of-pipe treatment consisting of chemical precipitation and sedimentation (BPT technology), with the addition of in-process wastewater flow reduction and filtration. Flow reductions are based on 90 percent recycle of scrubber liquor, a rate demonstrated by one of the two direct discharger plants.

The pollutants specifically limited under BAT are arsenic, lead, molybdenum, nickel, selenium, fluoride, and ammonia. The priority pollutants chromium, copper, and zinc were also considered for regulation because they were found at treatable concentrations in the raw wastewaters from this subcategory. These pollutants were not selected for specific regulation because they will be effectively controlled when the regulated priority metals are treated to the levels achievable by the model BAT technology.

Implementation of the BAT limitations would remove annually an estimated 11 kg of priority metals greater than the estimated BPT removal. No additional ammonia is removed at BAT.

The costs and specific removal data for this subcategory are not presented here because the data on which they are based has been claimed to be confidential.

Secondary Molybdenum and Vanadium

The BAT limitations for the secondary molybdenum and vanadium subcategory are based on preliminary treatment consisting of ammonia air stripping followed by end-of-pipe treatment consisting of iron co-precipitation, chemical precipitation and sedimentation (BPT technology) and filtration.

The pollutants specifically limited under BAT are arsenic, chromium, lead, molybdenum, nickel, iron, and ammonia. The priority pollutants antimony, beryllium, cadmium, and zinc were also considered for regulation because they were found at treatable concentrations in the raw wastewaters from this

subcategory. These pollutants were not selected for specific regulation because they will be effectively controlled when the regulated priority metals are treated to the concentrations achievable by the model BAT technology. EPA is providing limitations for the following pollutants as guidance for permitting authorities: copper, zinc, aluminum, boron, cobalt, germanium, manganese, tin, titanium, and vanadium.

Implementation of the BAT limitations would remove annually an estimated 76 kg of priority metals greater than the estimated BPT removal.

The costs and specific removal data for this subcategory are not presented here because the data on which they are based has been claimed to be confidential.

Primary Nickel and Cobalt

The BAT limitations for the primary nickel and cobalt subcategory are based on preliminary treatment consisting of ammonia steam stripping followed by end-of-pipe treatment consisting of chemical precipitation and sedimentation (BPT technology), and filtration. A filter is presently utilized by the one plant in this subcategory.

The pollutants specifically limited under BAT are cobalt, copper, nickel, and ammonia. The priority pollutant zinc was also considered for regulation because it was found at treatable concentrations in the raw wastewaters from this subcategory. This pollutant was not selected for specific regulation because it will be effectively controlled when the regulated priority metals are treated to the levels achievable by the model BAT technology.

Implementation of the BAT limitations would remove annually an estimated 5 kg of toxic metals greater than the estimated BPT removal.

The costs and specific removal data for this subcategory are not presented here because the data on which they are based has been claimed to be confidential.

Primary Precious Metals and Mercury

The BAT limitations for the primary precious metals and mercury subcategory are based on preliminary treatment consisting of oil skimming and end-of-pipe treatment consisting of chemical precipitation and sedimentation (BPT technology), with the addition of in-process wastewater flow reduction, filtration and ion-exchange.

The pollutants specifically limited under BAT are gold, lead, mercury, silver, and zinc. The priority pollutants arsenic, cadmium, chromium, copper, nickel and thallium were also considered for regulation because they were found at treatable

concentrations in the raw wastewaters from this subcategory. These pollutants were not selected for specific regulation because they will be effectively controlled when the regulated priority metals are treated to the levels achievable by the model BAT technology.

Implementation of the BAT limitations would remove annually an estimated 1.0 kg of priority metals greater than the estimated BPT removal. Estimated capital cost for achieving BAT is \$3,025, and annualized cost is \$27,300.

Secondary Precious Metals

The BAT limitations for the secondary precious metals subcategory are based on preliminary treatment consisting of cyanide precipitation and ammonia steam stripping and end-of-pipe treatment consisting of chemical precipitation and sedimentation (BPT technology), with the addition of in-process wastewater flow reduction, filtration and ion exchange. Flow reductions are based on recycle of scrubber effluent. Twenty-one of the 29 existing plants currently have scrubber liquor recycle rates of 90 percent or greater. A filter is also presently utilized by one plant in the subcategory.

The pollutants specifically limited under BAT are copper, cyanide, zinc, ammonia, gold, palladium, and platinum. The priority pollutants antimony, arsenic, cadmium, chromium, lead, nickel, selenium, silver and thallium were also considered for regulation because they were found at treatable concentrations in the raw wastewaters from this subcategory. These pollutants were not selected for specific regulation because they will be effectively controlled when the regulated priority metals are treated to the levels achievable by the model BAT technology.

Implementation to the BAT limitations would remove annually an estimated 10 kg of priority pollutants greater than the estimated BPT removal. No additional ammonia or cyanide is removed at BAT.

The costs and specific removal data for this subcategory are not presented here because the data on which they are based has been claimed to be confidential.

Primary Rare Earth Metals

The BAT limitations that were promulgated for the primary rare earth metals subcategory on September 20, 1985 have been withdrawn. These limitations were withdrawn because EPA failed to adequately address the sole plant's comments in the Administrative Record. Therefore, national BAT limitations are not available for this subcategory, and a rare earth metal manufacturing plant's effluent limitations will need to be developed by the local permitting authority through the NPDES program.

Secondary Tantalum

The BAT limitations for the secondary tantalum subcategory are based on chemical precipitation and sedimentation (BPT technology) with the addition of filtration.

The pollutants specifically limited under BAT are copper, lead, nickel, zinc, and tantalum. The priority pollutants antimony, beryllium, cadmium, chromium, and silver were also considered for regulation because they were found at treatable concentrations in the raw wastewaters from this subcategory. These pollutants were not selected for specific regulation because they will be effectively controlled when the suggested priority metals are treated to the levels achievable by the model BAT technology.

Implementation of the BAT limitations would remove annually an estimated 4.8 kg of metal priority pollutants more than the estimated BPT removal.

The costs and specific removal data for this subcategory are not presented here because the data on which they are based has been claimed to be confidential.

Secondary Tin

The BAT limitations for the secondary tin subcategory are based on preliminary treatment consisting of cyanide precipitation when required, and end-of-pipe treatment consisting of chemical precipitation and sedimentation (BPT technology), with the addition of filtration.

The pollutants specifically limited under BAT are arsenic, cyanide, lead, iron, tin, and fluoride. The priority pollutants antimony, cadmium, chromium, copper, nickel, selenium, silver, thallium, and zinc were also considered for regulation because they were found at treatable concentrations in the raw wastewaters from this subcategory. These pollutants were not selected for specific regulation because they will be effectively controlled when the regulated priority metals are treated to the levels achievable by the model BAT technology.

Implementation to the BAT limitations would remove annually an estimated 26 kg of priority metals over the estimated BPT discharge. An additional 128 kg of fluoride is removed annually at BAT. The costs and specific removal data for this subcategory are not presented here because the data on which they are based has been claimed to be confidential.

Primary and Secondary Titanium

EPA is exempting from limitations those titanium plants which do not practice electrolytic recovery of magnesium and which use vacuum distillation instead of leaching to purify titanium sponge. BAT limitations are promulgated for all other titanium plants based on chemical precipitation, sedimentation, and oil skimming pretreatment where required (BPT technology), plus flow

reduction and filtration. Flow reduction is based on 90 percent recycle of scrubber effluent through holding tanks and 90 percent recycle of casting contact cooling water through cooling towers.

The pollutants specifically limited under BAT are chromium, lead, nickel, and titanium. The priority pollutants antimony, cadmium, copper, thallium, and zinc were also considered for regulation because they were found at treatable concentrations in the raw wastewaters from this subcategory. These pollutants were not selected for specific regulation because they will be effectively controlled when the regulated priority metals are treated to the levels achievable by the model BAT technology.

Implementation of the BAT limitations would remove annually an estimated 299 kg to priority pollutants from the current discharge. Estimated capital cost for achieving BAT is \$1,030,000, and annualized cost is \$585,000.

Secondary Tungsten and Cobalt

The BAT limitations for the secondary tungsten and cobalt subcategory are based on preliminary treatment consisting of ammonia steam stripping and oil skimming, and end-of-pipe treatment consisting of chemical precipitation and sedimentation (BPT technology), plus filtration.

The pollutants specifically limited under BAT are cobalt, copper, nickel, tungsten, and ammonia. The priority pollutants arsenic, cadmium, chromium, lead, silver, and zinc were also considered for regulation because they were found at treatable concentrations in the raw wastewaters from this subcategory. These pollutants were not selected for specific regulation because they will be effectively controlled when the regulated priority metals are treated to the levels achievable by the model BAT technology.

Implementation of the BAT limitations would remove annually an estimated 100 kg of priority pollutants more than estimated BPT removal.

The costs and specific removal data for this subcategory are not presented here because the data on which they are based has been claimed to be confidential.

Secondary Uranium

The BAT limitations for the secondary uranium subcategory are based on end-of-pipe treatment consisting of chemical precipitation and sedimentation (BPT technology), and filtration. Flow reduction of laundry wastewater is included in BAT.

The pollutants specifically limited under BAT are chromium, copper, nickel, and fluoride. The priority pollutants antimony, arsenic, cadmium, lead, selenium, silver, zinc, and the nonconventional pollutant uranium were also considered for

regulation because they were found at treatable concentrations in the raw wastewaters from the subcategory. These pollutants were not selected for specific regulation because they will be effectively controlled when the regulated priority metals are treated to the levels achievable by the model BAT technology. Guidance is being provided to permit writers for the control of uranium.

Implementation of the BAT limitations would remove annually an estimated 126 kg of priority metals from the current discharge. Estimated capital cost for achieving BAT is \$88,000, and annualized cost is \$107,000 (1982 dollars).

Primary Zirconium and Hafnium

EPA is exempting from limitations those plants which only produce zirconium or zirconium-nickel alloys by magnesium reduction of ZrO_2 . Limitations apply to all other plants in the subcategory. BAT limitations are based on the same flow allowances provided at BPT (cyanide precipitation, ammonia steam stripping and chemical precipitation and sedimentation), plus in-process wastewater flow reduction and filtration.

The pollutants specifically limited under BAT are chromium, cyanide, lead, nickel, and ammonia. The priority pollutants cadmium, thallium, zinc, and the nonconventional pollutants zirconium and hafnium were also considered for regulation because they were found at treatable concentrations in the raw wastewaters from this subcategory. These pollutants were not selected for specific regulation because they will be effectively controlled when the regulated priority metals are treated to the levels achievable by the model BAT technology.

The costs and specific removal data for this subcategory are not presented here because the data on which they are based has been claimed to be confidential.

REGULATED POLLUTANT PARAMETERS

Presented in Section VI of this document is a list of the pollutant parameters found at concentrations and frequencies above treatable concentrations that warrant further consideration. Although these pollutants were found at treatable concentrations, the Agency is not promulgating regulation of each pollutant selected for further consideration. The high cost associated with analysis of metal priority pollutants has prompted EPA to develop an alternative method for regulating and monitoring toxic pollutant discharges from the nonferrous metals manufacturing category. Rather than developing specific effluent mass limitations and standards for each of the priority metals found in treatable concentrations in the raw wastewater from a given subcategory, the Agency is promulgating effluent mass limitations only for those pollutants generated in the greatest quantities as shown by the pollutant reduction benefit analysis.

By establishing limitations and standards for certain metal pollutants, dischargers will attain the same degree of control over metal pollutants as they would have been required to achieve had all the metal pollutants been directly limited. This approach is technically justified since the treatable concentrations achievable with chemical precipitation and sedimentation technology are based on optimized treatment for concomitant multiple metals removal. Thus, even though metals have somewhat different theoretical solubilities, they will be removed at very nearly the same rate in a chemical precipitation and sedimentation treatment system operated for multiple metals removal. Filtration as part of the technology basis is likewise justified because this technology removes metals non-preferentially.

The Agency has excluded several toxic organic pollutants from specific regulation in the primary tungsten, primary columbium-tantalum, and secondary silver subcategories because they were found in trace (de minimus quantities) amounts and are neither causing nor likely to cause toxic effects.

The conventional pollutants oil and grease, pH, and TSS are excluded from regulation in BAT. They are regulated by BCT. Table X-2 (page 416) presents the pollutants selected for specific regulation in BAT and Table X-3 (page 419) presents those pollutants that are effectively controlled by technologies upon which are based other effluent limitations and guidelines. Table X-4 (page 424) presents those pollutants excluded because they are neither causing nor likely to cause toxic effects. A more detailed discussion on the selection and exclusion of priority pollutants is presented in Sections VI and X of each subcategory supplement.

EXAMPLE OF THE BUILDING BLOCK APPROACH IN DEVELOPING PERMITS

That there is a wide range of differences in manufacturing facilities has been emphasized by industry representatives and observed by Agency personnel. This diversity of processes makes it virtually impossible to establish effluent limitations and standards on a whole plant basis such that they are fair and achievable for industry and protective of the environment. To better accomplish these seemingly mutually exclusive goals, the Agency has adopted the building block approach to developing discharge limits for use in water discharge permits. The building block approach allows the permit writer to establish appropriate and achievable effluent limits for any discharge point by combining appropriate limitations based upon the various processes that contribute wastewater to the discharge point.

Each building block represents a single process or discharge stream from a process within the subcategory. Because of differences in manufacturing processes, all building blocks will not occur in every plant in a subcategory. Similarly, the amount of material processed through any building block may vary from plant to plant both because of the product output of the plant

and the manufacturing processes used. The building block approach takes both of these variables into account; the first by allowing the selection of only those building blocks that are in use and the second by relating the quantity of pollutant allowed to be discharged to the materials processed or produced by a building block. This measure of production is called a production normalizing parameter (PNP) and is specific to each building block.

As a simplified example, consider a facility which produces aluminum from bauxite and treats the wastewater prior to discharge. The facility in this example discharges wastewater from potroom wet air pollution control and direct chill casting. Only a part of the aluminum reduced in the potroom is processed through the direct chill casting operation; the remainder is cast into sow molds and generates no process wastewater. By multiplying the production for each of these operations by the limitations or standards in 40 CFR 421 for potroom wet air pollution control and direct chill casting and by summing the products obtained for each of these waste streams, the permit writer can obtain the allowable mass discharge.

The permit writer must develop a quantification of the PNP for each building block so that it is a reasonable representation of the actual production level of the building block. The factors to be taken into account in this quantification and the procedures for calculating the reasonable representation of the actual production have been reviewed in the development of 40 CFR 126. The permit writer is expected to take into account production variations in establishing a reasonable measure of the actual production for use in the calculation of the discharge allowance.

If, for example, the reasonable representation of the actual production associated with the potroom wet air pollution control system is 550 kkg/day and the reasonable representation of the production of aluminum through direct chill casting is 410 kkg/day the maximum for any one day discharge limit based on the best available technology economically achievable (BAT) for the pollutant nickel is 0.72486 kg/day as calculated below:

Potroom Wet Air Pollution Control

$$(550 \text{ kkg/day}) \times (0.733 \text{ mg/kg}) \times (10^{-3} \text{ mg/kg}) \\ = 0.42515 \text{ kg nickel, maximum for any one day}$$

Direct Chill Casting

$$(410 \text{ kkg/day}) \times (0.731 \text{ mg/kg}) \times (10^{-3} \text{ mg/kg}) \\ = 0.29971 \text{ kg nickel, maximum for any one day}$$

$$\text{Total} = 0.72486 \text{ kg nickel, maximum for any one day}$$

Table X-1

OPTIONS CONSIDERED FOR EACH OF THE NONFERROUS
METALS MANUFACTURING SUBCATEGORIES

<u>Subcategory</u>	<u>Options Considered</u>			
	<u>A</u>	<u>B</u>	<u>C</u>	<u>E</u>
Primary Aluminum Smelting	X	X	X	X
Secondary Aluminum Smelting	X	X	X	
Primary Copper Electrolytic Refining	X	X	X	
Primary Zinc	X	X	X	
Primary Lead	X	X	X	
Metallurgical Acid Plants	X	X	X	
Primary Tungsten	X	X	X	
Primary Columbium-Tantalum	X	X	X	
Secondary Silver	X	X	X	
Secondary Lead	X	X	X	
Primary Antimony	X		X	
Primary Beryllium	X ¹		X	
Primary and Secondary Germanium and Gallium	X		X	
Secondary Indium	X		X	
Secondary Mercury	X		X	
Primary Molybdenum and Rhenium	X	X	X	
Secondary Molybdenum and Vanadium	X		X	
Primary Nickel and Cobalt	X		X	
Secondary Nickel	X		X	
Primary Precious Metals and Mercury	X	X	X	
Secondary Precious Metals	X	X	X	
Primary Rare Earth Metals	X	X	X	X
Secondary Tantalum	X		X	
Secondary Tin	X ¹		X	
Primary and Secondary Titanium	X	X	X	
Secondary Tungsten and Cobalt	X		X	
Secondary Uranium	X		X	
Primary Zirconium and Hafnium	X ¹		X	

¹Includes recycle of scrubber liquors as part of Option A.

Table X-2

BAT REGULATED POLLUTANT PARAMETERS

<u>Subcategory</u>	<u>Pollutant Parameters</u>
Primary Aluminum Smelting	73. benzo(a)pyrene 114. antimony 121. cyanide (total) 124. nickel aluminum fluoride
Secondary Aluminum	122. lead 128. zinc aluminum ammonia (N) phenolics (total; by 4-AAP method)
Primary Electrolytic Copper Refining	114. arsenic 120. copper 124. nickel
Primary Lead	122. lead 128. zinc
Primary Zinc	118. cadmium 120. copper 122. lead 128. zinc
Metallurgical Acid Plants	115. arsenic 118. cadmium 120. copper 122. lead 128. zinc
Primary Tungsten	122. lead 128. zinc ammonia (N)
Primary Columbium-Tantalum	122. lead 128. zinc ammonia (N) fluoride
Secondary Silver	120. copper 128. zinc ammonia (N)

Table X-2 (Continued)

BAT REGULATED POLLUTANT PARAMETERS

<u>Subcategory</u>	<u>Pollutant Parameters</u>
Secondary Lead	114. antimony 115. arsenic 122. lead 128. zinc ammonia (N)
Primary Antimony	114. antimony 115. arsenic 123. mercury
Primary Beryllium	117. beryllium 119. chromium (total) 120. copper 121. cyanide ammonia (as N) fluoride
Primary and Secondary Germanium and Gallium	115. arsenic 122. lead 128. zinc fluoride
Primary Molybdenum and Rhenium	115. arsenic 122. lead 124. nickel 125. selenium fluoride molybdenum ammonia (as N)
Secondary Molybdenum and Vanadium	115. arsenic 119. chromium 122. lead 124. nickel molybdenum ammonia (as N) iron
Primary Nickel and Cobalt	120. copper 124. nickel cobalt ammonia (as N)
Primary Precious Metals and Mercury	122. lead 123. mercury 126. silver 128. zinc gold

Table X-2 (Continued)

BAT REGULATED POLLUTANT PARAMETERS

<u>Subcategory</u>	<u>Pollutant Parameters</u>
Secondary Precious Metals	120. copper 121. cyanide 128. zinc ammonia (as N) gold palladium platinum
Primary Rare Earth Metals	9. hexachlorobenzene 119. chromium (total) 122. lead 124. nickel
Secondary Tantalum	120. copper 122. lead 124. nickel 128. zinc tantalum
Secondary Tin	115. arsenic 121. cyanide 122. lead iron tin fluoride
Primary and Secondary Titanium	119. chromium (total) 122. lead 124. nickel titanium
Secondary Tungsten and Cobalt	120. copper 124. nickel cobalt tungsten ammonia (as N)
Secondary Uranium	119. chromium (total) 120. copper 124. nickel fluoride
Primary Zirconium and Hafnium	119. chromium (total) 121. cyanide (total) 122. lead 124. nickel ammonia (as N)

Table X-3

PRIORITY POLLUTANTS EFFECTIVELY CONTROLLED BY TECHNOLOGIES UPON
WHICH ARE BASED OTHER EFFLUENT LIMITATIONS AND GUIDELINES

<u>Subcategory</u>	<u>Pollutant Parameters</u>
Primary Aluminum Smelting	1. acenaphthene
	39. fluoranthene
	55. naphthalene
	72. benzo(a)anthracene (1,2-benzanthracene)
	76. chrysene
	78. anthracene (a)
	79. benzo(ghi)perylene (1,11-benzoperylene)
	80. fluorene
	81. phenanthrene (a)
	82. dibenzo(a,h)anthracene (1,2,5,6-dibenzanthracene)
	84. pyrene
	115. arsenic
	116. asbestos (Fibrous)
	118. cadmium
	119. chromium (Total)
	120. copper
	122. lead
125. selenium	
128. zinc	
	(a) Reported together.
Secondary Aluminum	65. phenol
	118. cadmium
Primary Electrolytic Copper Refining	119. chromium (Total)
	122. lead
	126. silver
	128. zinc
Primary Lead	116. asbestos (Fibrous)
	118. cadmium
Primary Zinc	115. arsenic
	116. asbestos (Fibrous)
	119. chromium (Total)
	124. nickel
	126. silver

Table X-3 (Continued)

TOXIC POLLUTANTS EFFECTIVELY CONTROLLED BY TECHNOLOGIES
UPON WHICH ARE BASED OTHER EFFLUENT LIMITATIONS AND GUIDELINES

<u>Subcategory</u>	<u>Pollutants</u>
Metallurgical Acid Plants	114. antimony 119. chromium (Total) 123. mercury 124. nickel 125. selenium 126. silver
Primary Tungsten	118. cadmium 119. chromium (Total) 124. nickel 125. silver 127. thallium
Primary Columbium-Tantalum	114. antimony 115. arsenic 116. asbestos (Fibrous) 118. cadmium 119. chromium (Total) 120. copper 124. nickel 125. selenium 127. thallium
Secondary Silver	114. antimony 115. arsenic 118. cadmium 119. chromium (Total) 121. cyanide 122. lead 124. nickel 125. selenium 126. silver 127. thallium
Secondary Lead	118. cadmium 119. chromium (Total) 120. copper 124. nickel 126. silver 127. thallium
Primary Antimony	118. cadmium 120. copper 128. zinc

Table X-3 (Continued)

TOXIC POLLUTANTS EFFECTIVELY CONTROLLED BY TECHNOLOGIES
UPON WHICH ARE BASED OTHER EFFLUENT LIMITATIONS AND GUIDELINES

<u>Subcategory</u>	<u>Pollutants</u>
Primary and Secondary Germanium and Gallium	114. antimony
	118. cadmium
	119. chromium
	120. copper
	124. nickel
	125. selenium
	126. silver
	127. thallium
Primary Molybdenum and Rhenium	119. chromium (total)
	120. copper
	128. zinc
Secondary Molybdenum and Vanadium	114. antimony
	117. beryllium
	118. cadmium
	128. zinc
Primary Nickel and Cobalt	128. zinc
Primary Precious Metals and Mercury	115. arsenic
	118. cadmium
	119. chromium
	120. copper
	124. nickel
	127. thallium
Secondary Precious Metals	114. antimony
	115. arsenic
	118. cadmium
	119. chromium
	122. lead
	124. nickel
	125. selenium
	126. silver
	127. thallium

Table X-3 (Continued)

PRIORITY POLLUTANTS EFFECTIVELY CONTROLLED BY TECHNOLOGIES UPON
WHICH OTHER EFFLUENT LIMITATIONS AND GUIDELINES ARE BASED

<u>Subcategory</u>	<u>Pollutant Parameters</u>
Primary Rare Earth Metals	4. benzene
	115. arsenic
	118. cadmium
	120. copper
	125. selenium
	126. silver
	127. thallium
	128. zinc
Secondary Tantalum	114. antimony
	117. beryllium
	118. cadmium
	119. chromium (total)
	126. silver
Secondary Tin	114. antimony
	118. cadmium
	119. chromium
	120. copper
	124. nickel
	125. selenium
	126. silver
	127. thallium
128. zinc	
Primary and Secondary Titanium	114. antimony
	118. cadmium
	120. copper
	128. zinc
Secondary Tungsten and Cobalt	115. arsenic
	118. cadmium
	119. chromium
	124. lead
	126. silver
	128. zinc

Table X-3 (Continued)

PRIORITY POLLUTANTS EFFECTIVELY CONTROLLED BY TECHNOLOGIES UPON
WHICH OTHER EFFLUENT LIMITATIONS AND GUIDELINES ARE BASED

<u>Subcategory</u>	<u>Pollutant Parameters</u>
Secondary Uranium	114. antimony 115. arsenic 118. cadmium 122. lead 125. selenium 126. silver 128. zinc
Primary Zirconium and Hafnium	118. cadmium 127. thallium 128. zinc

Table X-4

TOXIC POLLUTANTS DETECTED BUT ONLY IN TRACE AMOUNTS
AND ARE NEITHER CAUSING NOR LIKELY TO CAUSE TOXIC EFFECTS

<u>Subcategory</u>	<u>Pollutants</u>
Primary Tungsten	11. 1,1,1-trichloroethane
	55. naphthalene
	65. phenol
	73. benzo(a)pyrene
	79. benzo(ghi)perylene
	82. dibenzo(a,h)anthracene
	85. tetrachloroethylene
	86. toluene
Primary Columbium-Tantalum	4. benzene
	6. carbon tetrachloride
	7. chlorobenzene
	8. 1,2,4-trichlorobenzene
	10. 1,2-dichloroethane
	30. 1,2-trans-dichloroethylene
	38. ethylbenzene
	51. chlorodibromomethane
	85. tetrachloroethylene
	87. trichloroethylene
Secondary Silver	4. benzene
	6. carbon tetrachloride (tetrachloroemethane)
	10. 1,2-dichloroethane
	11. 1,1,1-trichloroethane
	29. 1,1-dichloroethylene
	30. 1,2-trans-dichloroethylene
	38. ethylbenzene
	84. pyrene
	85. tetrachloroethylene
	86. toluene
87. trichloroethylene total phenolics (by 4-AAP method)	

SECTION XI

NEW SOURCE PERFORMANCE STANDARDS

The basis for new source performance standards (NSPS) under Section 306 of the Clean Water Act is the best available demonstrated technology (BDT). New plants have the opportunity to design the best and most efficient production processes and wastewater treatment technologies. Therefore, NSPS includes process changes, in-plant controls (including elimination to wastewater discharges for some streams), operating procedure changes, and end-of-pipe treatment technologies to reduce pollution to the maximum extent possible. This section describes the control technology for treatment of wastewater from new sources and presents mass discharge limitations of regulated pollutants for NSPS, based on the described control technology.

TECHNICAL APPROACH TO NSPS

All wastewater treatment technologies applicable to a new source in the nonferrous metals manufacturing category have been considered previously for the BAT options. For this reason, four options were considered as the basis for NSPS, all identical to BAT options in Section X. In summary, the treatment technologies considered for nonferrous metals manufacturing new facilities are outlined below:

Option A is based on:

Chemical precipitation of metals followed by sedimentation, and, where required, ion exchange, sulfide precipitation, iron co-precipitation, cyanide precipitation, ammonia air or steam stripping, and oil skimming.

Option B is based on:

Option A plus process wastewater flow reduction by the following methods:

Contact cooling water recycle through cooling towers.
Holding tanks for all other process wastewater subject to recycle.

Option C is based on:

Option B plus multimedia filtration.

Option E is based on:

Option C plus activated carbon adsorption applied to the total plant discharge as a polishing step.

The options listed above are general and can be applied to all subcategories. Wastewater flow reduction within the nonferrous metals manufacturing category is generally based on the recycle of scrubbing liquors and casting contact cooling water. Additional flow reduction is achievable for new sources through alternative process methods which are subcategory-specific. Additional flow reduction attainable for each subcategory is discussed later in this section regarding the NSPS option selection.

For several subcategories, the regulatory production normalized flows for NSPS are the same as the production normalized flows for the selected BAT option. The mass of pollutant allowed to be discharged per mass of product is calculated by multiplying the appropriate treatment effectiveness value (one-day maximum and 10-day average values) (mg/l) by the production normalized flows (l/kg). When these calculations are performed, the mass-based NSPS can be derived for the selected option. Effluent concentrations attainable by the NSPS treatment options are identical to those presented in Section VII of this document (Table VII-21 page xxx).

MODIFICATIONS TO EXISTING NSPS

New source performance standards had been promulgated previously for the primary and secondary aluminum smelting subcategories. The technology basis for these standards was lime precipitation, sedimentation, and in-process flow reduction of process wastewater. EPA is promulgating modifications to these NSPS to incorporate changes promulgated for BAT and to include additional flow reductions possible at new sources in the primary aluminum subcategory.

As discussed in Section IX, the metallurgical acid plants subcategory has been modified to include acid plants associated with primary lead and zinc smelters, and primary molybdenum roasters. This is based on the similarity between discharge rates and effluent characteristics of wastewaters from all metallurgical acid plants.

NSPS OPTION SELECTION

In general, EPA is promulgating that the best available demonstrated technology be equivalent to BAT technology (NSPS Option C). For the subcategories where EPA has reserved setting BAT limitations, chemical precipitation, sedimentation, and filtration is generally selected as the technology basis for NSPS. The principal treatment method for Option C is in-process flow reduction, chemical precipitation, sedimentation, and multimedia filtration. Option C also includes ion exchange, sulfide precipitation, cyanide precipitation, iron co-precipitation, ammonia air or steam stripping, and oil skimming, where required. As discussed in Sections IX and X, these technologies are currently used at plants within this point

source category. The Agency recognizes that new sources have the opportunity to implement more advanced levels of treatment without incurring the costs to retrofit equipment, and the costs of partial or complete shutdown to install new production equipment. Specifically the design of new plants can be based on recycle of contact cooling water through cooling towers, recycle of air pollution control scrubber liquor or the use of dry air pollution control equipment. New plants also have the opportunity to consider alternate degassing or slag granulation methods during the preliminary design of the facility.

The data relied upon for selection of NSPS were primarily the data developed for existing sources which included costs on a plant-by-plant basis along with retrofit costs where applicable. The Agency believes that compliance costs could be lower for new sources than the cost estimates for equivalent existing sources, because production processes can be designed on the basis of lower flows and there will be no costs associated with retrofitting the in-process controls. Therefore, new sources will have costs that are not greater than the costs that existing sources would incur in achieving equivalent pollutant discharge reduction. Based on this analysis, the Agency believes that the selected NSPS (NSPS Option C) is an appropriate choice.

Section II of each subcategory supplement presents a summary of the NSPS for the Nonferrous Metals Manufacturing Point Source Category. The pollutants selected for regulation for each subcategory are identical to those selected for BAT with the addition of conventional pollutant parameters (e.g., TSS, oil and grease, and pH). The pollutants regulated under NSPS are presented for each subcategory in Table XI-1 (page 435). Presented below is a brief discussion describing the technology option selected for NSPS for each subcategory.

Primary Aluminum Smelting

New source performance standards for primary aluminum are based on BAT plus additional flow reduction. Additional flow reduction is achievable through the use of dry air pollution scrubbing on potlines, anode bake plants, and anode paste plants and elimination of potroom and degassing scrubber discharges. Potroom scrubbing discharges are eliminated by design of efficient potline scrubbing (eliminating potroom scrubbing completely) or 100 percent recycle (with blowdown recycled to casting). Degassing scrubbers are limited by replacing chlorine degassing with inert gases.

These flow reductions are demonstrated at existing plants, but are not included in BAT because they might involve substantial retrofit costs at other existing plants. However, new plants can include these reductions in plant design at no significant additional cost.

The Agency does not believe that the promulgated NSPS will provide a barrier to entry for new facilities. In fact,

installation of dry scrubbing instead of wet scrubbing in new facilities reduces the cost of end-of-pipe treatment by reducing the overall volume of wastewater discharged.

Secondary Aluminum Smelting

The technology basis and discharge allowances for NSPS are equivalent to that of the promulgated BAT, with the exception of dross washing. Dross washing is not provided a discharge allowance in the NSPS because of the demonstration of dry milling in the subcategory. Dry milling is not required for existing sources due to the extensive retrofit costs of installing milling, grinding, and screening operations. However, new sources have the opportunity to install the best equipment without the cost of major retrofits. The Agency also does not believe that new plants could achieve any additional flow reduction for chlorine demagging and casting contact cooling beyond that promulgated for BAT.

Primary Copper Smelting

The promulgated NSPS for the primary copper smelting subcategory is zero discharge of all process pollutants without a catastrophic storm discharge allowance. The Agency believes that new smelting facilities can be constructed using cooling towers to cool and recirculate casting contact cooling water and slag granulation wastewater instead of large volume cooling impoundments. This technology is demonstrated in this subcategory. Thus, this modification eliminates the allowance for the catastrophic precipitation discharge allowed at BAT. The costs associated with construction and operation of a cooling tower system are not significantly greater than those for cooling impoundments, and as such, the Agency believes that the promulgated NSPS will not constitute a barrier for entry of new facilities. As a result of this modification, the discharge of toxic metals during months of net precipitation will be eliminated.

Primary Electrolytic Copper Refining

The promulgated NSPS for the primary electrolytic copper refining subcategory are equivalent to promulgated BAT. Review of the subcategory indicates that no additional demonstrated technologies exist that improve on BAT. The Agency also believes that new plants could not achieve any additional flow reduction beyond that promulgated for BAT.

Secondary Copper

New source performance standards for the secondary copper subcategory are promulgated as zero discharge of all process wastewater pollutants. It is believed that new sources can be constructed with demonstrated cooling tower technology exclusively and that the cost of cooling towers instead of cooling impoundments is minimal. This eliminates the allowance

needed for catastrophic stormwater provided at BAT. Therefore, NSPS, as defined, does not constitute a barrier to entry for new plants.

Primary Lead

The promulgated NSPS prohibit the discharge of all process wastewater pollutants from primary lead smelting except those industrial hygiene streams provided an allowance at BAT and for which an allowance remains necessary. Zero discharge is achievable through complete recycle and reuse of dross and blast furnace slag granulation wastewater or through slag dumping. Elimination of discharge from dross or blast furnace slag granulation is demonstrated in four of the six existing plants, but it is not included at BAT because it would involve substantial retrofit costs for the one existing discharger by requiring the installation of a modified sintering machine. New plants can include elimination of the discharge from the slag granulation process in the plant design at no significant additional cost. Elimination of the sinter plant materials handling wet air pollution control waste stream is based on dry scrubbing to control fugitive lead emissions during materials handling. Therefore, NSPS does not present any barrier to entry for new plants.

Primary Zinc

New source performance standards for the primary zinc subcategory are promulgated equal to BAT. Review of the subcategory indicates that no new demonstrated technologies exist that improve on BAT.

Dry scrubbing is not demonstrated for controlling emissions from zinc reduction furnaces, leaching, and product casting. The nature of these emissions (acidic fumes, hot particulate matter) technically precludes the use of dry scrubbers. Therefore, a discharge allowance is included from this source at NSPS equivalent to that promulgated for BAT. The Agency believes that new plants could not achieve any additional flow reduction beyond that promulgated for BAT.

Metallurgical Acid Plants

New source performance standards for the metallurgical acid plants subcategory are promulgated equal to BAT. Review of the subcategory indicates that no new demonstrated technologies exist that improve on BAT. The Agency also does not believe that new plants could achieve any additional flow reduction beyond that promulgated for BAT.

Primary Tungsten

For the primary tungsten subcategory, NSPS are promulgated as equal to BAT. Review of the subcategory indicates that no new demonstrated technologies that improve on BAT exist.

Dry scrubbing is not demonstrated for controlling emissions from acid leaching, APT conversion to oxides and tungsten reduction furnaces. The nature of these emissions (acid fumes, hot particulate matter) technically precludes the use of dry scrubbers. Therefore, a discharge allowance is included for these sources at NSPS equivalent to that promulgated for BAT. Also, the Agency does not believe that new plants could achieve any additional flow reduction beyond the 90 percent scrubber effluent recycle promulgated for BAT.

Primary Columbiu-m-Tantalum

The promulgated NSPS for the primary columbiu-m-tantalum subcategory is equivalent to BAT. Review of the subcategory indicates that no new demonstrated technologies that improve on BAT exist.

Dry scrubbing is not demonstrated for controlling emissions from concentration digestion, solvent extraction, precipitation, oxides calcining, and reduction of tantalum salt to metal. The nature of these emissions (acidic fumes, hot particulate matter) technically precludes the use of dry scrubbers. Therefore, a discharge allowance is included for these sources at NSPS equivalent to that promulgated for BAT. The Agency also does not believe that new plants could achieve any additional flow reduction beyond that promulgated for BAT.

Secondary Silver

The promulgated NSPS for the secondary silver subcategory is equivalent to BAT. Review of the subcategory indicates that no new demonstrated technologies that improve on BAT exist.

Dry scrubbing is not demonstrated for controlling emissions from film stripping and precipitation of film stripping solutions, precipitation and filtration of photographic solutions, and leaching and precipitation of non-photographic solutions. The nature of these emissions (acidic fumes, hot particulate matter) technically precludes the use of dry scrubbers. Therefore, a discharge allowance is included for these sources at NSPS equivalent to that promulgated for BAT. The Agency also does not believe that new plants could achieve any additional flow reduction beyond that promulgated for BAT.

Secondary Lead

The promulgated NSPS for the secondary lead subcategory is equivalent to BAT with additional flow reduction over BAT levels using dry scrubbing to control emissions from kettle refining. Review of the subcategory indicates that no other new demonstrated technologies that improve on BAT exist.

Existing wet scrubbers are used to control emissions and prevent baghouse fires caused by sparking when sawdust and phosphorus are

applied to the surface of the metal while in the kettle. Dry scrubbers can be used for this purpose if spark arrestors and settling chambers are installed to trap sparks. According to the Secondary Lead Smelters Association, this is a demonstrated and viable technology option. Dry scrubbing is not required at BAT because of the extensive retrofit costs of switching from wet to dry scrubbing. Dry scrubbing, however, is not demonstrated for controlling emissions from blast and reverberatory furnaces, and the nature of these emissions (hot particulate matter) precludes the use of dry scrubbing. Therefore, a discharge allowance is included for this source at NSPS equivalent to that promulgated for BAT. The Agency also does not believe that new plants could achieve any additional flow reduction beyond that promulgated for BAT.

Primary Antimony

The promulgated NSPS for primary antimony are equal to BAT. We do not believe that new plants could achieve any reduction in flow beyond the flows promulgated for BAT. Because NSPS is equal to BAT, we believe that the NSPS will not pose a barrier to the entry of new plants into this subcategory.

Primary Beryllium

The promulgated NSPS for primary beryllium are equal to BAT. We do not believe that new plants could achieve any flow reduction beyond the allowances promulgated for BAT. Because NSPS is equal to BAT, we believe that the NSPS will not have a detrimental impact on the entry of new plants into this subcategory.

Primary and Secondary Germanium and Gallium

The promulgated NSPS for primary and secondary germanium and gallium are equal to BAT. We do not believe that new plants could achieve any reduction in flow beyond the flow allowances promulgated for BAT. Because NSPS is equal to BAT, we believe that the NSPS will not have a detrimental impact on the entry of new plants into this subcategory.

Secondary Indium

The NSPS for the secondary indium subcategory are based on chemical precipitation and sedimentation, (the same model technology as PSES). The pollutants and pollutant parameters specifically limited under NSPS are cadmium, lead, zinc, indium, total suspended solids, and pH. The priority pollutants chromium, nickel, selenium, silver, and thallium were also considered for regulation because they are present at treatable concentrations in the raw wastewaters from this subcategory. These pollutants were not selected for specific regulation because they will be effectively controlled when the regulated priority metals are treated to the levels achievable by the model technology.

The costs and specific removal data for this subcategory are not presented here because the data on which they are based has been claimed to be confidential. We believe the promulgated NSPS are economically achievable, and that they do not pose a barrier to entry of new plants into this subcategory.

Secondary Mercury

The promulgated NSPS for secondary mercury are based on chemical precipitation, sedimentation, and filtration. This technology is fully demonstrated in many nonferrous metals manufacturing subcategories and would be expected to perform at the same level in this subcategory.

The pollutants specifically limited under NSPS are lead, mercury, TSS, and pH. The priority pollutants arsenic, cadmium, copper, silver, and zinc were also considered for regulation because they are present at treatable concentrations in the raw wastewaters from this subcategory. These pollutants were not selected for specific regulation because they will be effectively controlled when the regulated priority metals are treated to the levels achievable by the model technology.

We believe the promulgated NSPS are economically achievable, and that they are not a barrier to entry of new plants into this subcategory.

Primary Molybdenum and Rhenium

The promulgated NSPS for primary molybdenum and rhenium are equal to BAT. We do not believe that new plants could achieve any flow reduction beyond the allowances promulgated for BAT. Because NSPS are equal to BAT, we believe that the NSPS will not have a detrimental impact on the entry to new plants into this subcategory.

Secondary Molybdenum and Vanadium

The promulgated NSPS for secondary molybdenum and vanadium are equal to BAT. We do not believe that new plants could achieve any reduction in flow beyond the flow allowances promulgated for BAT. Because NSPS are equal to BAT, we believe that the NSPS will not pose a barrier to the entry of new plants into this subcategory.

Primary Nickel and Cobalt

The promulgated NSPS for primary nickel and cobalt are equal to BAT. We do not believe that new plants could achieve any reduction in flow beyond the flow allowances promulgated for BAT. Because NSPS are equal to BAT, we believe that the NSPS will not pose a barrier to the entry of new plants into this subcategory.

Secondary Nickel

The promulgated NSPS for secondary nickel are equivalent to PSES (chemical precipitation and sedimentation technology). We do not believe that new plants could achieve any reduction in flow beyond the flow allowances promulgated for PSES. Because NSPS are equal to PSES, we believe that the NSPS will not pose a barrier to the entry of new plants into this subcategory.

Primary Precious Metals and Mercury

The promulgated NSPS for primary precious metals and mercury are equal to BAT. We do not believe that new plants could achieve any reduction in flow beyond the allowances promulgated for BAT. Because NSPS are equal to BAT, we believe that the NSPS will not have a detrimental impact on the entry of new plants into this subcategory.

Secondary Precious Metals

The promulgated NSPS for secondary precious metals are equal to BAT. We do not believe that new plants could achieve any reduction in flow beyond the allowances promulgated for BAT. Because NSPS are equal to BAT, we believe that the NSPS are economically achievable, and that they are not a barrier to entry of new plants into this subcategory.

Primary Rare Earth Metals

The promulgated NSPS for primary rare earth metals are equal to BAT, which is based on in-process flow reduction, lime, settle and filter treatment, followed by activated carbon polishing technology for control of toxic inorganic and organic pollutants. Although the BPT and BAT limitations were remanded for this subcategory, EPA feels that new sources would be able to economically achieve these new source standards.

The NSPS for this subcategory are based on in-process wastewater flow reduction, followed by lime, settle, and filter and activated carbon adsorption end of pipe treatments. Flow reduction is based on 90 percent recycle of scrubber effluent. Activated carbon technology is transferred from the iron and steel category where it is a demonstrated technology for removal of toxic organic pollutants.

The pollutants specifically limited under NSPS are hexachlorobenzene, chromium, lead, and nickel. The priority pollutants benzene, arsenic, cadmium, copper, selenium, silver, thallium, and zinc were also considered for regulation because they were found at treatable concentrations in the raw wastewaters from this subcategory. These pollutants were not selected for specific regulation because they will be effectively controlled when the regulated priority pollutants are treated to the levels achievable by the model NSPS technology.

Secondary Tantalum

The promulgated NSPS for secondary tantalum are equal to BAT. We do not believe that new plants could achieve any reduction in flow beyond the allowances promulgated for BAT. Because NSPS are equal to BAT, we believe that the NSPS will not pose a barrier to the entry of new plants into this subcategory.

Secondary Tin

The promulgated NSPS for secondary tin are equal to BAT. We do not believe that new plants could achieve any reduction in flow beyond the allowances promulgated for BAT. Because NSPS are equal to BAT, we believe that the NSPS will not pose a barrier to the entry of new plants into this subcategory.

Primary and Secondary Titanium

The promulgated NSPS for primary and secondary titanium are equal to BAT plus flow reduction technology with additional flow reduction for four streams. Zero discharge is promulgated for chip crushing, sponge crushing and screening, and scrap milling wet air pollution control wastewater based on dry scrubbing. Zero discharge is also promulgated for chlorine liquefaction wet air pollution control based on by-product recovery of scrubber liquor as hypochlorous acid. Cost for dry scrubbing air pollution control in a new facility is no greater than the cost for wet scrubbing which was the basis for BAT cost estimates. Because NSPS are equal to BAT, we believe that the NSPS will not pose a barrier to the entry of new plants into this subcategory.

Secondary Tungsten and Cobalt

The promulgated NSPS for secondary tungsten and cobalt are equal to BAT. We do not believe that new plants could achieve any reduction in flow beyond the allowances promulgated for BAT. Because NSPS are equal to BAT, we believe that the NSPS will not pose a barrier to the entry of new plants into this subcategory.

Secondary Uranium

The promulgated NSPS for secondary uranium are equal to BAT. We do not believe that new plants could achieve any reduction in flow beyond the allowances promulgated for BAT. Because NSPS are equal to BAT, we believe that the NSPS will not pose a barrier to the entry of new plants into this subcategory.

Primary Zirconium and Hafnium

The promulgated NSPS for primary zirconium and hafnium are equal to BAT. We do not believe that new plants could achieve any reduction in flow beyond the allowances promulgated for BAT. Because NSPS are equal to BAT, we believe that the NSPS will not pose a barrier to the entry of new plants into this subcategory.

Table XI-1

REGULATED POLLUTANT PARAMETERS

Subcategory	Pollutant Parameters
Primary Aluminum Smelting	73. benzo(a)pyrene 114. antimony 121. cyanide (total) 124. nickel aluminum fluoride oil and grease TSS pH
Secondary Aluminum Smelting	122. lead 128. zinc aluminum ammonia (N) oil and grease phenolics (total; by 4-AAP method) TSS pH
Primary Electrolytic Copper Refining	114. arsenic 120. copper 124. nickel TSS pH
Primary Lead	122. lead 128. zinc TSS pH
Primary Zinc	118. cadmium 120. copper 122. lead 128. zinc TSS pH
Metallurgical Acid Plants	115. arsenic 118. cadmium 120. copper 122. lead 128. zinc TSS pH

Table XI-1 (Continued)

REGULATED POLLUTANT PARAMETERS

Subcategory	Pollutant Parameters
Primary Tungsten	122. lead
	128. zinc ammonia (N) TSS pH
Primary Columbium-Tantalum	122. lead
	128. zinc ammonia (N) fluoride TSS pH
Secondary Silver	120. copper
	128. zinc ammonia (N) TSS pH
Secondary Lead	114. antimony
	115. arsenic
	122. lead
	128. zinc ammonia (N) TSS pH
Primary Antimony	114. antimony
	115. arsenic
	123. mercury
	TSS pH
Primary Beryllium	117. beryllium
	119. chromium (total)
	120. copper
	121. cyanide ammonia (as N) fluoride TSS pH
Primary and Secondary Germanium and Gallium	115. arsenic
	122. lead
	128. zinc fluoride TSS pH

Table XI-1 (Continued)

REGULATED POLLUTANT PARAMETERS

Subcategory	Pollutant Parameters
Secondary Molybdenum and Vanadium	115. arsenic 119. chromium 122. lead 124. nickel molybdenum ammonia (as N) iron TSS pH
Primary Nickel and Cobalt	120. copper 124. nickel cobalt ammonia (as N) TSS pH
Primary Precious Metals and Mercury	122. lead 123. mercury 126. silver 128. zinc gold oil and grease TSS pH
Secondary Precious Metals	120. copper 121. cyanide 128. zinc ammonia (as N) gold palladium platinum TSS pH
Primary Rare Earth Metals	119. chromium (Total) 122. lead 124. nickel TSS pH

Table XI-1 (Continued)

REGULATED POLLUTANT PARAMETERS

Subcategory	Pollutant Parameters
Secondary Tantalum	120. copper 122. lead 124. nickel 128. zinc tantalum TSS pH
Secondary Tin	115. arsenic 121. cyanide 122. lead iron tin fluoride TSS pH
Primary and Secondary Titanium	119. chromium (total) 122. lead 124. nickel titanium oil and grease TSS pH
Secondary Tungsten and Cobalt	120. copper 124. nickel cobalt tungsten oil and grease ammonia (as N) TSS pH
Secondary Uranium	119. chromium (total) 120. copper 124. nickel fluoride TSS

Table XI-1 (Continued)

REGULATED POLLUTANT PARAMETERS

Subcategory	Pollutant Parameters
Primary Zirconium and Hafnium	119. chromium (total) 121. cyanide (total) 122. lead 124. nickel ammonia (as N) TSS pH

THIS PAGE INTENTIONALLY LEFT BLANK

SECTION XII

PRETREATMENT STANDARDS

Section 307(b) of the Clean Water Act requires EPA to promulgate pretreatment standards for existing sources (PSES), which must be achieved within three years of promulgation. PSES are designed to prevent the discharge of pollutants which pass through, interfere with, or are otherwise incompatible with the operation of publicly owned treatment works (POTW). The Clean Water Act of 1977 adds a new dimension by requiring pretreatment for pollutants, such as heavy metals, that limit POTW sludge management alternatives, including the beneficial use of sludges on agricultural lands. The legislative history of the 1977 Act indicates that pretreatment standards are to be technology-based, analogous to the best available technology for removal of priority pollutants.

Section 307(c) of the Act requires EPA to promulgate pretreatment standards for new sources (PSNS) at the same time that it promulgates NSPS. New indirect discharge facilities, like new direct discharge facilities, have the opportunity to incorporate the best available demonstrated technologies, including process changes, in-plant controls, and end-of-pipe treatment technologies, and to use plant site selection to ensure adequate treatment system installation.

General Pretreatment Regulations for Existing and New Sources of Pollution were published in the Federal Register, Vol. 46, No. 18, Wednesday, January 28, 1981. These regulations describe the Agency's overall policy for establishing and enforcing pretreatment standards for new and existing users of a POTW and delineates the responsibilities and deadlines applicable to each party in this effort. In addition, 40 CFR Part 403, Section 403.5(b), outlines prohibited discharges which apply to all users of a POTW.

This section describes the treatment and control technology for pretreatment of process wastewaters from existing sources and new sources, and presents mass discharge limitations of regulated pollutants for existing and new sources, based on the described control technology. It also serves to summarize changes from previous rulemakings in the nonferrous metals manufacturing category.

REGULATORY APPROACH

There are 125 facilities, representing 28 percent of the nonferrous metals manufacturing category, who discharge wastewaters to POTW. Pretreatment standards are established to ensure removal of pollutants discharged by these facilities which may interfere with, pass through, or be incompatible with POTW operations. A determination of which pollutants may pass through or be incompatible with POTW operations, and thus be subject to

pretreatment standards, depends on the level of treatment used by the POTW. In general, more pollutants will pass through or interfere with a POTW using primary treatment (usually physical separation by settling) than one which has installed secondary treatment (settling plus biological treatment).

Many of the pollutants contained in nonferrous metals manufacturing wastewaters are not biodegradable and are, therefore, not effectively treated by such systems. Furthermore, these pollutants have been known to pass through or interfere with the normal operations of these systems. Problems associated with the uncontrolled release of pollutant parameters identified in nonferrous metals manufacturing process wastewaters to POTW were discussed in Section VI.

The Agency based the selection of pretreatment standards for the nonferrous metals manufacturing category on the minimization of pass-through of priority pollutants at POTW. For each subcategory, the Agency compared removal rates for each priority pollutant limited by the pretreatment options to the removal rate for that pollutant at well-operated POTW. The POTW removal rates were determined through a study conducted by the Agency at over 40 POTW and a statistical analysis of the data. (See Fate of Priority Pollutants in Publicly Owned Treatment Works, EPA 440/1-80-301, October, 1980; and Determining National Removal Credits for Selected Pollutants for Publicly Owned Treatment Works, EPA 440/82-008, September, 1982.) The POTW removal rates are presented below:

<u>Priority Pollutant</u>	<u>POTW Removal Rate</u>
Antimony	0%
Arsenic	0%
Cadmium	38%
Chromium	65%
Copper	58%
Cyanide	52%
Lead	48%
Mercury	69%
Nickel	19%
Selenium	0%
Silver	66%
Zinc	65%
Hexachlorobenzene	12%
Ammonia	40%
Fluoride	0%
Total Regulated Metals	62%

There were no data concerning POTW removals for beryllium, boron, cobalt, germanium, indium, molybdenum, radium 226, thallium, tin, titanium, and uranium, to compare with our estimates of in-plant treatment. Removal of these pollutants is solubility related. Since the removal of metal pollutants for which data are available is also solubility related, EPA believes that these pollutants may pass through a POTW. It was assumed, therefore,

that these metals pass through a POTW because they are soluble in water and are not degradable. Pass-through data are not available for benzo(a)pyrene; however, pass-through data for five other polynuclear aromatic hydrocarbons do not exceed 83 percent. This value was used for organics pass-through calculations.

A pollutant is deemed to pass through the POTW when the average percentage removed nationwide by well-operated POTW, meeting secondary treatment requirements, is less than the percentage removed by direct dischargers complying with BAT effluent limitations guidelines for that pollutant. (See generally, 46 FR 9415-16 (January 28, 1981).) For example, if the selected PSES option removed 90 percent of the cadmium generated by the subcategory, cadmium would be considered to pass through because a well-operated POTW would be expected to remove 38 percent. Conversely, if the selected PSES option removed only 30 percent of the cadmium generated by the subcategory, it would not be considered to pass through. In the latter case, cadmium would not be selected for specific regulation because a well-operated POTW would have a greater removal efficiency.

The analysis described above was performed for each subcategory starting with the pollutants selected for regulation at BAT. The conventional pollutant parameters (TSS, pH, and oil and grease) and aluminum were not considered for regulation under pretreatment standards. The conventional pollutants are effectively controlled by POTW, while aluminum is used to enhance settling. For those subcategories where ammonia was selected for specific limitation, it will also be selected for limitation under pretreatment standards. Most POTW in the United States are not designed for nitrification. Hence, aside from incidental removal, most, if not all, of the ammonia introduced into POTW will pass through into receiving waters without treatment.

An examination of the percent removal for the selected pretreatment options indicated that the pretreatment option selected removed at least 95 percent of the priority pollutants generated in the nonferrous metals manufacturing point source category. Consequently, the priority pollutants regulated for each subcategory under BAT will also be regulated under pretreatment standards. Table XII-1 (page 460) presents the pollutants selected for regulation for pretreatment standards.

MODIFICATIONS TO EXISTING PRETREATMENT STANDARDS

Existing pretreatment standards proposed for the nonferrous metals manufacturing category are being revised to incorporate the building block approach as discussed earlier. In addition, information has become available regarding proposed pretreatment standards that warrant revision of promulgated standards.

Primary Aluminum Smelting

Pretreatment standards for new sources had been promulgated previously to limit the quantity of fluoride discharged from

primary aluminum smelters to POTW. The technology basis for this limitation was lime precipitation and sedimentation. PSNS for primary aluminum has been revised to incorporate the building block approach and the same technology basis as for new sources. Since the PSNS regulation was proposed, three additional technologies have been identified as demonstrated or transferable to the primary aluminum subcategory. These technologies, filtration, activated carbon, and dry alumina for scrubbing systems, would greatly reduce the amount of toxic pollutants discharged by a new source. A thorough discussion of the building block approach and selection of regulated pollutant parameters is presented in the primary aluminum supplement.

Secondary Aluminum Smelting

The previously promulgated pretreatment standards for existing secondary aluminum facilities limited the quantity of oil and grease allowed to be discharged from metal cooling, the pH from demagging fume scrubbers, and the quantity of ammonia discharged from residue milling. These mass limitations have been revised to include additional waste streams that warrant regulations and to upgrade the technology basis so that it is analogous to the promulgated BAT.

Pretreatment standards previously promulgated for new sources require zero discharge of all process generated pollutants into POTW with the exception of demagging fume scrubber liquor. A discharge from this scrubber was allowed only when chlorine is used as a demagging agent. Mass limitations developed for this discharge were based on chemical precipitation and sedimentation technology. Revision of the promulgated pretreatment standard was necessary in light of comments and information received and to incorporate the more thorough building block approach (see Section X). An extensive description of the development of these standards can be found in the secondary aluminum supplement.

Secondary Copper

The promulgated pretreatment standards for existing sources allows the discharge of process wastewaters subject to limitations developed from chemical precipitation and sedimentation technology. Currently promulgated BAT limitations, however, require zero discharge of all process wastewaters. Therefore, PSES is being promulgated as zero discharge through recycle and reuse making it equivalent to BAT.

Metallurgical Acid Plants

As discussed in Section IX, the metallurgical acid plants subcategory has been modified to include acid plants associated with primary molybdenum roasters. This is based on the similarity between discharge rates and effluent characteristics of wastewaters from all metallurgical acid plants.

EPA is not extend the applicability of the existing

metallurgical acid plant pretreatment standards to include molybdenum acid plants because there are no indirect discharging molybdenum acid plants.

We have extended the applicability of the existing PSNS for metallurgical acid plants to include metallurgical acid plants associated with primary molybdenum roasters. It is necessary to promulgate PSNS to prevent pass-through of arsenic, cadmium, copper, lead, and zinc. These priority pollutants are removed by a well-operated POTW achieving secondary treatment at an average of 42 percent, while BAT level technology removes approximately 83 percent.

We believe that the promulgated PSNS are achievable, and that they are not a barrier to entry of new plants into this subcategory.

OPTION SELECTION

The treatment schemes considered for pretreatment standards for existing sources are identical to those considered for BAT. The treatment schemes considered for pretreatment standards for new sources are also identical to those considered for BAT with the exception of primary aluminum smelting, secondary aluminum, primary lead, and secondary lead, where additional flow reduction is required. Each of the options considered builds upon the BPT technology basis of chemical precipitation and sedimentation. Depending on the pollutants present in the subcategories' raw wastewaters, a combination of the treatment technologies listed below were considered:

- o Option A - End-of-pipe treatment consisting of chemical precipitation, sedimentation, and ion-exchange, and preliminary treatment, where necessary, consisting of oil skimming, cyanide precipitation, sulfide precipitation, iron co-precipitation, and ammonia air or steam stripping. This combination of technology reduces priority metals and cyanide, conventional, and nonconventional pollutants.
- o Option B - Option B is equal to Option A preceded by flow reduction of process wastewater through the use of cooling towers for contact cooling water and holding tanks for all other process wastewater subject to recycle.
- o Option C - Option C is equal to Option B plus end-of-pipe polishing filtration for further reduction of priority metals and TSS.
- o Option E - Option E consists of Option C plus activated carbon adsorption applied to the total plant discharge as a polishing step to reduce priority organic concentrations.

The general approach taken by the Agency for pretreatment standards for this category is presented below. The mass-based standards for each subcategory may be found in Section II of each subcategory supplement. The options selected for the category on which to base pretreatment standards are discussed below.

Primary Aluminum Smelting

Pretreatment standards for existing sources will not be promulgated for the primary aluminum smelting subcategory since there are no existing indirect dischargers.

The technology basis for PSNS is identical to NSPS and includes flow reduction, lime precipitation, sedimentation, and filtration for control of toxic metals, and cyanide precipitation preliminary treatment.

Secondary Aluminum Smelting

The technology basis for PSES is in-process flow reduction lime, precipitation, sedimentation, and filtration. Preliminary treatment consisting of ammonia steam stripping and activated carbon adsorption is included for selected streams. The achievable concentration for ammonia steam stripping is based on iron and steel manufacturing category data. Flow reduction for the selected technology option over current discharge rates represents a 75 percent reduction in flow. Ammonia steam stripping and lime precipitation and sedimentation, and filter technologies are presently demonstrated in the nonferrous metals manufacturing category. Ammonia air stripping was the technology basis for the previously promulgated PSES. Steam stripping was promulgated in this rule instead of air stripping because it is a superior technology in that it does not transfer the pollutant from one media to another. Activated carbon adsorption is selected to control phenolics in the scrubber stream from delacquering operations.

Implementation of the promulgated PSES would remove annually an estimated 11,300 kg/yr of toxic pollutants, 96 kg/yr of ammonia, and 212 kg/yr of phenolics over estimated raw discharges. Capital cost for achieving promulgated PSES is \$2.3 million (1982 dollars), and annual cost of \$1.4 million.

The technology basis used to develop standards for new sources is identical to those used for existing sources. There is no demonstrated technology that is better than the PSES technology.

Primary Copper Smelting

No pretreatment standards for existing sources are promulgated for the primary copper smelting subcategory since there are no existing indirect dischargers.

The technology basis for promulgated PSNS is identical to NSPS

(and BAT), which is zero discharge of all process wastewater pollutants, with no allowance for catastrophic stormwater discharge. New indirect dischargers will be constructed with cooling towers, not cooling impoundments, since they will be located near POTW, suggesting that they will be near heavily populated areas where land is scarce making the cost of acquiring land to install an impoundment relatively high. Thus, we do not believe there are any incremental costs associated with PSNS.

Primary Electrolytic Copper Refining

No pretreatment standards for existing sources are promulgated for the primary electrolytic copper refining subcategory since there are no existing indirect dischargers.

The technology basis of pretreatment for new sources is identical to BAT and NSPS and is based on lime precipitation, sedimentation, filtration, and 90 percent recycle for casting contact cooling water. As in NSPS, all other waste streams generated at copper refineries are not included in the flow allowance.

Secondary Copper

As mentioned earlier in this section, PSES for secondary copper is being modified to make it equivalent to BAT, or zero discharge. Implementation of the promulgated PSES would remove an estimated 9,500 kg/yr of toxic pollutants from raw discharges. The estimated capital cost for achieving the promulgated PSES is \$0.654 million (1982 dollars) and the annual cost is \$0.277 million.

The technology basis for promulgated PSNS is identical to NSPS, PSES, and BAT. No allowance for catastrophic stormwater discharges is provided as is discussed in Chapter XI for NSPS.

Primary Lead

The technology for promulgated PSES is equivalent to BAT treatment and consists of in-process flow reduction, lime precipitation, sedimentation, sulfide precipitation (and sedimentation), and multimedia filtration. Implementation of the promulgated PSES will remove an estimated 117 kg/yr of toxic pollutants over raw discharge. The capital cost for achieving PSES is \$0.057 million (1982 dollars) and the annual cost is \$0.011 million.

The technology basis for promulgated PSNS is equivalent to NSPS or zero discharge except for industrial hygiene streams provided an allowance at NSPS. As discussed in Chapter XI for NSPS, slag removed from dross reverberatory furnaces contains economical recoverable amounts of lead that are granulated before recycling. New facilities will have the opportunity to install dry slag conditioning devices to eliminate the usage of wastewater in this process or implement a 100 percent recycle system of slag

granulation wastewater. Elimination of the sinter plant materials handling wet air pollution control stream can also be accomplished with dry methods or 100 percent recycle. The Agency believes the elimination of these process wastewater sources can be accomplished without additional cost beyond BAT-equivalent costs.

Primary Zinc

The technology basis for the promulgated PSES in the primary zinc subcategory is equivalent to BAT. The treatment consists of in-process flow reduction, lime precipitation, sedimentation, sulfide precipitation (and sedimentation), and multimedia filtration. Implementation of the PSES would remove an estimated 650,000 kg/yr of toxic pollutants over raw discharge. The estimated capital cost for achieving PSES is \$0.12 million (1982 dollars) and the annual cost is \$0.058 million.

The technology basis for promulgated pretreatment standards for new sources is equivalent to the NSPS basis of flow reduction, lime precipitation, sedimentation, sulfide precipitation and sedimentation, and filtration. The PSNS flow allowances are based on minimization of process wastewater wherever possible through the use of cooling towers to recycle contact cooling water and sedimentation basins for wet scrubbing wastewater. The discharges from contact cooling and scrubbers is based on 90 percent recycle. Elimination of wastewater from scrubbers by installing dry scrubbers is not demonstrated for controlling emissions from zinc reduction furnaces, leaching, and product casting. The nature of emissions from these sources (acidic fumes, hot particulate matter) technically precludes the use of dry scrubbers.

Metallurgical Acid Plants

The technology basis for the promulgated PSES in the metallurgical acid plants subcategory is equivalent to BAT. The treatment consists of in-process flow reduction, lime precipitation, sedimentation, and multimedia filtration. Sulfide precipitation is included for all primary lead and primary zinc acid plants and one primary copper acid plant. Implementation of the promulgated PSES would remove approximately 12,500 kg/yr of toxic metals over raw discharge. The capital cost for PSES is an estimated \$0.16 million (1982 dollars) and the annual cost is \$0.085 million.

The promulgated technology basis for pretreatment for new sources is equivalent to the NSPS basis of flow reduction, lime precipitation, sedimentation, sulfide precipitation, and filtration. There is no demonstrated technology that provides better pollutant removal than that promulgated for PSNS. The acid plant blowdown allowance allocated for PSNS is based on 90 percent recycle. The Agency believes that no additional flow reduction is feasible for new sources because the only other available flow reduction technology, reverse osmosis, is not

demonstrated nor is it clearly transferable for this subcategory.

Primary Tungsten

The technology basis for the promulgated PSES in the primary tungsten subcategory is equivalent to BAT. The selected treatment consists of in-process flow reduction, lime precipitation and sedimentation, ammonia steam stripping, and filtration.

Implementation of the promulgated PSES limitations would remove an estimated 3,400 kg/yr of toxic pollutants over estimated raw discharge, and an estimated 63,320 kg/yr of ammonia. The capital cost for achieving promulgated PSES is \$0.568 million (1982 dollars), and annual cost of \$0.445 million.

The technology basis for promulgated PSNS is identical to PSES. The PSES flow allowances are based on minimization of process wastewater wherever possible through the use of cooling towers to recycle contact cooling water and sedimentation basins for wet scrubbing wastewater. These discharges are based on 90 percent recycle of these waste streams. Dry scrubbing is not demonstrated for controlling emissions from acid leaching, APT conversion to oxides and tungsten reduction furnaces. The nature of these emissions (acidic fumes, hot particulate matter) technically precludes the use of dry scrubbers.

Primary Columbium-Tantalum

The technology basis for the promulgated PSES in the primary columbium-tantalum subcategory is equivalent to BAT. The selected treatment consists of in-process flow reduction, lime precipitation and sedimentation, ammonia steam stripping, and filtration. Flow reduction is based on 90 percent recycle of scrubber effluent that is the flow basis of BAT. This flow rate is achieved by both indirect dischargers in the subcategory, and filters are demonstrated at 23 plants in the nonferrous metals manufacturing category.

Implementation of the promulgated PSES limitations would remove 18,590 kg/yr of toxic pollutants, 290,460 kg/yr of ammonia and 400,175 kg/yr of fluoride from raw discharges. Capital cost for achieving promulgated PSES is \$1.03 million (1982 dollars), and annual cost of \$0.7 million.

The technology basis for promulgated PSNS is identical to NSPS, PSES and BAT. There is no known economically feasible, demonstrated technology that is better than PSES technology. The PSES flow allowances are based on minimization of process wastewater wherever possible through the use of cooling towers to recycle contact cooling water and sedimentation basins for wet scrubbing wastewater. The discharges are based on 90 percent recycle of these waste streams. Dry scrubbing is not demonstrated for controlling emissions from concentration digestion, solvent extraction, precipitation, oxides calcining,

and reduction of tantalum salt to metal. The nature of these emissions (acidic fumes, hot particulate matter) technically precludes the use of dry scrubbers.

Secondary Silver

The technology basis for the promulgated PSES in the secondary silver subcategory is equivalent to BAT. The selected treatment consists of in-process flow reduction, lime precipitation, sedimentation, and multimedia filtration, along with ammonia steam stripping preliminary treatment. Flow reduction is based on complete recycle of furnace wet air pollution control. Filtration is currently in place at eight of the 26 indirect discharging secondary silver plants. Promulgated PSES would remove an estimated 4,259 kg/yr of toxic pollutants and approximately 42,400 kg/yr of ammonia generated by the industry. Capital cost for achieving promulgated PSES is \$0.63 million (1982 dollars), with an annual cost of \$0.42 million.

The promulgated technology basis for PSNS is equivalent to the NSPS basis of in-process flow reduction, lime precipitation and sedimentation, filtration, and ammonia steam stripping. Review of the subcategory indicates that no new demonstrated technologies that improve on this BAT technology exist.

Dry scrubbing is not demonstrated for controlling emissions from film stripping and precipitation of film stripping solutions, precipitation and filtration of photographic solutions, and leaching and precipitation of non-photographic solutions. The nature of these emissions (acidic fumes, hot particulate matter) technically precludes the use of dry scrubbers. Therefore, an allowance is included for these sources at PSES equivalent to that promulgated for BAT and PSES. The Agency also does not believe that new plants could achieve any additional flow reduction beyond that promulgated for BAT.

Secondary Lead

The technology basis for the promulgated PSES in the secondary lead subcategory is equivalent to BAT. The selected treatment consists of in-process flow reduction, lime precipitation, sedimentation, and multimedia filtration. Flow reduction is based on 90 percent recycle of casting contact cooling water through cooling towers. Filtration is achieved by five of the 26 indirect discharging secondary lead plants.

Implementation of the promulgated PSES would remove an estimated 46,500 kg/yr of toxic pollutants over estimated raw discharge. Capital cost for achieving promulgated PSES is \$4.26 million (1982 dollars), with an annual cost of \$2.51 million.

Pretreatment standards for new sources are equivalent to the NSPS basis of in-process flow reduction, lime precipitation, sedimentation and filtration with the additional flow reduction over BAT levels using dry scrubbing to control emissions from

kettle refining. Flow reduction is based on 90 percent recycle of scrubber effluent and casting contact cooling water using cooling towers and holding tanks. There is no known demonstrated technology that is better than the technology basis promulgated for new secondary lead plants. Existing wet scrubbers are used to control emissions and prevent baghouse fires caused by sparking when sawdust and phosphorus are applied to the surface of the metal while in the kettle. Dry scrubbers can be used for this purpose if spark arrestors and settling chambers are installed to trap sparks. According to the Secondary Lead Smelters Association, this is a demonstrated and viable technology option. Dry scrubbing is not required at BAT because of the extensive retrofit costs of switching from wet to dry scrubbing. Dry scrubbing is not demonstrated for controlling emissions from blast and reverberatory furnaces, and the nature of these emissions (hot particulate matter) precludes the use of dry scrubbing.

Primary Antimony

Pretreatment standards for existing sources were not promulgated for the primary antimony subcategory because there are no existing indirect dischargers. We have promulgated PSNS equivalent to NSPS and BAT. The technology basis for PSNS is identical to NSPS and BAT. It was necessary to promulgate PSNS to prevent pass-through of priority metals. These metals are removed by a well-operated POTW achieving secondary treatment at an average of 61 percent. PSNS technology removes these pollutants at an average of 98 percent. No additional flow reduction for new sources is feasible beyond the allowances promulgated for BAT. We believe that the PSNS are not a barrier to entry of new plants into this subcategory because they do not include any additional costs compared to BAT.

Primary Beryllium

Pretreatment standards for existing sources were not promulgated for the primary beryllium subcategory since there are no indirect dischargers. The technology basis for promulgated PSNS is identical to NSPS and BAT. It was necessary to promulgate PSNS to prevent pass-through of beryllium, chromium, copper, cyanide, and fluoride. These priority pollutants are removed by a well-operated POTW achieving secondary treatment at an average of 41 percent while BAT technology removes approximately 93 percent. The PSNS flow allowances are based on minimization to process wastewater wherever possible through the use of holding tanks for wet scrubbing wastewater. The flow allowances are identical to those promulgated for BAT.

Primary and Secondary Germanium and Gallium

EPA promulgated PSES and PSNS limitations for this subcategory based on chemical precipitation and sedimentation treatment.

We have promulgated PSES to prevent pass-through to arsenic,

lead, zinc, and fluoride. These pollutants are removed by a well-operated POTW achieving secondary treatment at an average of 33 percent while BAT technology removes approximately 87 percent.

Implementation of the PSES limitations would remove annually an estimated 564 kg of priority metal pollutants.

The costs and specific removal data for this subcategory are not presented here because the data on which they are based have been claimed to be confidential. The promulgated PSES will not result in adverse economic impacts.

We have promulgated PSNS equivalent to PSES, NSPS and BAT. The technology basis for promulgated PSNS is identical to NSPS, PSES, and BAT. The same pollutants pass through as at PSES, for the same reasons. We believe that the promulgated PSNS are not a barrier to entry of new plants into this subcategory because they do not include any additional costs compared to BAT.

Secondary Indium

PSES limitations for this subcategory are promulgated based on chemical precipitation and sedimentation technology. The pollutants specifically regulated under PSES are cadmium, lead, zinc, and indium. The priority pollutants chromium, nickel, selenium, silver, and thallium were also considered for regulation because they are present at treatable concentrations in the raw wastewaters from this subcategory. These pollutants were not selected for specific regulation because they will be effectively controlled when the regulated priority metals are treated to the levels achievable by the model technology. It is necessary to promulgate PSES to prevent pass-through of cadmium, lead, and zinc. These toxic pollutants are removed by a well-operated POTW achieving secondary treatment at an average of 38 percent while this BAT level technology removes approximately 90 percent.

Implementation of the PSES limitations would remove annually an estimated 586 kg of priority metals and 288 kg of indium.

We have promulgated PSNS equal to NSPS. The technology basis for PSNS is identical to NSPS. The same pollutants pass through as at PSES, for the same reasons.

We believe that the promulgated PSNS are achievable, and that they are not a barrier to entry of new plants into this subcategory.

Secondary Mercury

Pretreatment standards for existing sources were not promulgated for the secondary mercury subcategory since there are no existing indirect dischargers.

We have promulgated PSNS equivalent to NSPS for this subcategory. It was necessary to promulgate PSNS to prevent pass-through of

lead and mercury. These pollutants are removed by a well-operated POTW achieving secondary treatment at an average of 59 percent while PSNS level technology removes approximately 99 percent.

We believe that the promulgated PSNS are achievable, and that they are not a barrier to entry of new plants into this subcategory.

Primary Molybdenum and Rhenium

Pretreatment standards for existing sources were not promulgated for the primary molybdenum and rhenium subcategory since there are no existing indirect dischargers.

We have promulgated PSNS equal to BAT and NSPS for this subcategory. It was necessary to promulgate PSNS to prevent pass-through of arsenic, lead, nickel, selenium, molybdenum, and ammonia. These priority pollutants are removed by a well-operated POTW achieving secondary treatment at an average of 13 percent, while the NSPS and BAT level technology removes approximately 79 percent.

We believe that the promulgated PSNS are achievable, and that they are not a barrier to entry of new plants into this subcategory.

Secondary Molybdenum and Vanadium

Pretreatment standards for existing sources were not promulgated for the secondary molybdenum and vanadium subcategory since there are no existing indirect dischargers.

We have promulgated PSNS equal to BAT and NSPS for this subcategory. It was necessary to promulgate PSNS to prevent pass-through of arsenic, chromium, lead, nickel, molybdenum, iron, and ammonia. These priority pollutants are removed by a well-operated POTW achieving secondary treatment at an average of 23 percent, while the NSPS and BAT level technology removes approximately 98 percent.

The technology basis for PSNS is ammonia air stripping, iron co-precipitation, chemical precipitation, sedimentation, and filtration. The achievable concentration for ammonia air stripping is based on nonferrous metals manufacturing category data, as explained in the discussion of BPT and BAT in this subcategory supplement.

We believe that the promulgated PSNS are achievable, and that they are not a barrier to entry of new plants into this subcategory because they do not include any additional costs compared to BAT.

Primary Nickel and Cobalt

Pretreatment standards for existing sources were not promulgated for the primary nickel and cobalt subcategory since there are no existing indirect dischargers.

We have promulgated PSNS equal to BAT and NSPS for this subcategory. It was necessary to promulgate PSNS to prevent pass-through to copper, nickel, cobalt, and ammonia. These priority pollutants are removed by a well-operated POTW at an average of 26 percent, while 8AT technology removes approximately 58 percent.

The technology basis for PSNS is ammonia steam stripping, chemical precipitation and sedimentation, and filtration. The achievable concentration for ammonia steam stripping is based on iron and steel manufacturing category data, as explained in the discussion of BPT and BAT for this subcategory.

We believe that the promulgated PSNS are achievable, and that they are not a barrier to entry of new plants into this subcategory because they do not include any additional costs compared to BAT.

Secondary Nickel

PSES for this subcategory are promulgated based on chemical precipitation and sedimentation. The pollutants specifically regulated under PSES are chromium, copper, and nickel. The priority pollutants arsenic and zinc were also considered for regulation because they are present at treatable concentrations in the raw wastewaters from this subcategory. These pollutants were not selected for specific regulation because they will be effectively controlled when the regulated priority metals are treated to the levels achievable by the model technology. We are promulgating PSES to prevent pass-through to chromium, copper, and nickel. These pollutants are removed by a well-operated POTW at an average of 32 percent while PSES technology removes approximately 84 percent.

Implementation of the promulgated PSES limitations would remove annually an estimated 1,624 kg of priority metals from the raw waste loads. We estimate a capital cost of \$320,000 and an annualized cost of \$161,233 to achieve PSES. The promulgated PSES will not result in adverse economic impacts.

We have promulgated PSNS equivalent to NSPS and PSES. The same pollutants pass through at PSNS as at PSES, for the same reasons. The PSES flow allowances are based on minimization of process wastewater wherever possible.

We believe that the promulgated PSNS are achievable, and that they are not a barrier to entry of new plants into this subcategory.

Primary Precious Metals and Mercury

Pretreatment standards for existing sources were not promulgated for the primary precious metals and mercury subcategory because there are no existing indirect dischargers.

We have promulgated PSNS equal to BAT and NSPS for this subcategory. It was necessary to promulgate PSNS to prevent pass-through of gold, lead, mercury, silver, and zinc. These priority pollutants are removed by a well-operated POTW at an average of 62 percent, while the NSPS and BAT technology removes approximately 93 percent.

The technology basis for PSNS is oil skimming, chemical precipitation and sedimentation, wastewater flow reduction, filtration and ion exchange. Flow reduction is based on 90 percent recycle of scrubber effluent that is the flow basis of BAT.

We believe that the promulgated PSNS are achievable, and that they are not a barrier to entry to new plants into this subcategory because they do not include any additional costs compared to BAT.

Secondary Precious Metals

The technology basis for the promulgated PSES in the secondary precious metals subcategory is equivalent to BAT. It is necessary to promulgate PSES to prevent pass-through of copper, cyanide, zinc, ammonia, gold, palladium, and platinum. The priority pollutants are removed by a well-operated POTW achieving secondary treatment at an average of 32 percent while BAT level technology removes approximately 99 percent. The technology basis for PSES is chemical precipitation and sedimentation, ammonia steam stripping, cyanide precipitation, wastewater flow reduction, filtration, and ion exchange. The achievable concentration for ammonia steam stripping is based on iron and steel manufacturing category data, as explained in the discussion of BPT and BAT for this subcategory. Flow reduction is based on the same recycle of scrubber effluent and granulation water that is the flow basis of BAT. Recycle is practiced by 21 of the 29 existing plants in the subcategory.

Implementation of the promulgated PSES limitations would remove annually an estimated 110,300 kg of priority pollutants including 866 kg of cyanide, and an estimated 10,530 kg of ammonia from the raw waste load. Capital cost for achieving PSES is \$1,734,265 and annualized cost of \$1,059,367. The proposed PSES will not result in adverse economic impacts.

We have promulgated PSNS equivalent to NSPS and BAT. The technology basis for promulgated PSNS is identical to NSPS and BAT. The same pollutants pass through at PSNS as at PSES, for the same reasons. The NSPS flow allowances are based on minimization of process wastewater wherever possible through the use of holding tanks to recycle wet scrubbing wastewater and granulation water. The discharges are based on recycle of these waste

streams. We believe that the promulgated PSNS are achievable, and that they are not a barrier to entry of new plants into this subcategory because they do not include any additional costs compared to BAT and PSES.

Primary Rare Earth Metals

PSES and PSNS for this subcategory are based on chemical precipitation and sedimentation, in-process wastewater flow reduction, filtration, and activated carbon adsorption. Flow reduction is based on 90 percent recycle of scrubber effluent. Activated carbon technology is transferred from the iron and steel category where it is a demonstrated technology for removal of priority organic pollutants.

The pollutants specifically limited under PSES and PSNS are hexachlorobenzene, chromium, lead, and nickel. The priority pollutants benzene, arsenic, cadmium, copper, selenium, silver, thallium, and zinc were also considered for regulation because they were found at treatable concentrations in the raw wastewaters from this subcategory. These pollutants were not selected for specific regulation because they will be effectively controlled when the regulated priority pollutants are treated to the levels achievable by the model PSES and PSNS technology.

Secondary Tantalum

Pretreatment standards for existing sources were not promulgated for the secondary tantalum subcategory since there are no existing indirect dischargers.

We have promulgated PSNS equal to NSPS and BAT. It was necessary to promulgate PSNS to prevent pass-through of copper, lead, nickel, zinc, and tantalum. These priority pollutants are removed by a well-operated POTW achieving secondary treatment at an average of 48 percent, while BAT level technology removes approximately 99 percent.

We believe that the promulgated PSNS are achievable, and that they are not a barrier to entry to new plants into this subcategory because they do not include any additional costs compared to BAT.

Secondary Tin

The technology basis for the promulgated PSES in the secondary tin subcategory is equivalent to BAT. It is necessary to promulgate PSES to prevent pass-through to arsenic, cyanide, lead, iron, tin, and fluoride. These priority pollutants and fluoride are removed by a well-operated POTW achieving secondary treatment at an average of 17 percent while BAT technology removes approximately 97 percent. The technology basis for PSES is chemical precipitation, sedimentation, and filtration with preliminary treatment consisting of cyanide precipitation where required.

Implementation of the promulgated PSES limitations would remove annually an estimated 167 kg of priority metals, 6,227 kg of tin, 20 kg of cyanide, and 25,105 kg of fluoride over estimated current discharge. Capital cost for achieving PSES is \$160,187, and annual cost of \$50,044. The promulgated PSES will not result in adverse economic impacts.

We have promulgated PSNS equivalent to PSES, NSPS, and BAT. The technology basis for PSNS is identical to NSPS, PSES, and BAT. The same pollutants pass through at PSNS as at PSES, for the same reasons. The PSNS flow allowances are identical to the flow allowances for BAT, NSPS, and PSES.

There would be no additional cost for PSNS above the costs estimated for BAT. We believe that the promulgated PSNS are achievable, and that they are not a barrier to entry of new plants into this subcategory because they do not include any additional costs compared to BAT and PSES.

Primary and Secondary Titanium

We have promulgated PSES equal to BAT for this subcategory. It is necessary to promulgate PSES to prevent pass-through of chromium, lead, nickel, and titanium. These priority pollutants are removed by a well-operated POTW achieving secondary treatment at an average of 14 percent while BAT technology removes approximately 76 percent. Implementation of the promulgated PSES limitations would remove annually an estimated 1.7 kg of priority pollutants, and 147 kg of titanium from the current discharge.

The cost data for this subcategory are not presented here because the data on which they are based have been claimed to be confidential. The promulgated PSES will not result in adverse economic impacts.

We have promulgated PSNS equivalent to NSPS. The technology basis for promulgated PSNS is identical to NSPS. The same pollutants are regulated at PSNS as at PSES and they pass through at PSNS as at PSES, for the same reasons. The PSNS and NSPS flow allowances are based on minimization to process wastewater wherever possible through the use of cooling towers to recycle contact cooling water and holding tanks for wet scrubbing wastewater. The discharge allowance for pollutants is the same at PSNS and NSPS. The discharges are based on 90 percent recycle of these waste streams (see Section IX - recycle of wet scrubber and contact cooling water). As in NSPS, flow reduction beyond BAT (zero discharge) is promulgated for chip crushing, sponge crushing and screening, and scrap milling wet air pollution control wastewater based on dry scrubbing. Also, zero discharge is promulgated for chlorine liquification wet air pollution control wastewater based on by-product recovery.

We believe that the promulgated PSNS are achievable, and that they are not a barrier to entry of new plants into this

subcategory because they do not include any additional costs compared to BAT and PSES.

Secondary Tungsten and Cobalt

The technology basis for the promulgated PSES in the secondary tungsten and cobalt subcategory is equivalent to BAT and PSNS. It was necessary to promulgate PSES and PSNS to prevent pass-through to copper, nickel, cobalt, tungsten, and ammonia. These priority pollutants are removed by a well-operated POTW achieving secondary treatment at an average of 26 percent, while the NSPS and BAT level technology removes approximately 97 percent.

The technology basis for PSES and PSNS is ammonia steam stripping, oil skimming, chemical precipitation and sedimentation, and filtration. The achievable concentration for ammonia steam stripping is based on iron and steel manufacturing category data, as explained in the discussion of BPT and BAT for this subcategory.

Implementation of the PSES limitations would remove annually an estimated 13 kg of priority pollutants. Capital and annual costs expected to be incurred to achieve PSES are \$16,293 and \$8,765, respectively. The Agency has determined that PSES are economically achievable and will not result in adverse economic impacts.

We believe that the promulgated PSNS are achievable, and that they are not a barrier to entry of new plants into this subcategory because they do not include any additional costs compared to BAT.

Secondary Uranium

Pretreatment standards for existing sources were not promulgated for the secondary uranium subcategory since there are no existing indirect dischargers.

We have promulgated PSNS equal to BAT and NSPS for this subcategory. It was necessary to promulgate PSNS to prevent passthrough of chromium, copper, nickel, and fluoride. These priority pollutants are removed by a well-operated POTW achieving secondary treatment at an average of 40 percent, while the NSPS and BAT level technology removes approximately 88 percent.

The technology basis for PSNS is chemical precipitation, sedimentation, and filtration, plus in-process wastewater flow reduction.

We believe that the promulgated PSNS are achievable, and that they are not a barrier to entry of new plants into this subcategory because they do not include any additional costs compared to BAT.

Primary Zirconium and Hafnium

EPA did not promulgate pretreatment standards for existing sources for the primary zirconium and hafnium subcategory. We had proposed PSES for this subcategory in a two tier regulatory approach. However, we are excluding from national regulation plants which only reduce zirconium or zirconium-nickel alloys from zirconium dioxide with magnesium or hydrogen. Since the only indirect discharger in the subcategory complies with this requirement, we have decided not to establish PSES for this subcategory. However, this facility will still be subject to general pretreatment standards.

We are promulgating PSNS equivalent to NSPS and BAT. The technology basis for promulgated PSNS is identical to NSPS. The following priority pollutants pass through: chromium, cyanide, lead, nickel, and ammonia. It is necessary to promulgate PSNS to prevent pass-through. These pollutants are removed by a well-operated POTW achieving secondary treatment at an average of 30 percent, while BAT technology removes approximately 80 percent. We know of no economically feasible, demonstrated technology that is better than BAT and NSPS technology.

We believe that the promulgated PSNS are achievable, and that they are not a barrier to entry of new plants into this subcategory because they do not include any additional costs compared to BAT and PSES.

Table XII-1

POLLUTANTS SELECTED FOR REGULATION FOR PRETREATMENT
STANDARDS BY SUBCATEGORY

<u>Subcategory</u>	<u>Pollutant Parameters</u>
Primary Aluminum Smelting*	73. benzo(a)pyrene 114. antimony 121. cyanide (total) 124. nickel fluoride
Secondary Aluminum Smelting	122. lead 128. zinc ammonia (N) phenolics (by 4-AAP Method)
Primary Copper Smelting	
Primary Electrolytic Copper Refining*	114. arsenic 120. copper 124. nickel
Primary Lead	122. lead 128. zinc
Primary Zinc	118. cadmium 120. copper 122. lead 128. zinc
Metallurgical Acid Plants	115. arsenic 118. cadmium+ 120. copper 122. lead 128. zinc+
Primary Tungsten	122. lead 128. zinc ammonia (N)
Primary Columbium-Tantalum	122. lead 128. zinc ammonia (N) fluoride
Secondary Silver	120. copper 128. zinc ammonia (N)

Table XII-1 (Continued)

POLLUTANTS SELECTED FOR REGULATION FOR PRETREATMENT
STANDARDS BY SUBCATEGORY

<u>Subcategory</u>	<u>Pollutant Parameters</u>
Secondary Lead	114. antimony 115. arsenic 122. lead 128. zinc ammonia (N)
Primary Antimony	114. antimony 115. arsenic 123. mercury
Primary Beryllium	117. beryllium 119. chromium 120. copper 121. cyanide ammonia (as N) fluoride
Primary and Secondary Germanium and Gallium	115. arsenic 122. lead 128. zinc fluoride
Secondary Indium	118. cadmium 122. lead 128. zinc indium
Secondary Mercury	122. lead 123. mercury
Primary Molybdenum and Rhenium	115. arsenic 122. lead 124. nickel 125. selenium fluoride molybdenum ammonia (as N)
Secondary Molybdenum and Vanadium	115. arsenic 119. chromium 122. lead 124. nickel iron molybdenum ammonia (as N)

Table XII-1 (Continued)

POLLUTANTS SELECTED FOR REGULATION FOR PRETREATMENT
STANDARDS BY SUBCATEGORY

<u>Subcategory</u>	<u>Pollutant Parameters</u>
Primary Nickel and Cobalt	120. copper 124. nickel cobalt ammonia (as N)
Secondary Nickel	119. chromium 120. copper 124. nickel
Primary Precious Metals and Mercury	122. lead 123. mercury 126. silver 128. zinc gold
Secondary Precious Metals	120. copper 121. cyanide 128. zinc ammonia (as N) gold palladium platinum
Primary Rare Earth Metals	9. hexachlorobenzene 119. chromium (total) 122. lead 124. nickel
Secondary Tantalum	120. copper 122. lead 124. nickel 128. zinc tantalum
Secondary Tin	115. arsenic 121. cyanide 122. lead iron tin fluoride

Table XII-1 (Continued)

POLLUTANTS SELECTED FOR REGULATION FOR PRETREATMENT
STANDARDS BY SUBCATEGORY

<u>Subcategory</u>	<u>Pollutant Parameters</u>
Primary and Secondary Titanium	119. chromium (total) 122. lead 124. nickel titanium
Secondary Tungsten and Cobalt	120. copper 124. nickel cobalt tungsten ammonia (as N)
Secondary Uranium	119. chromium (total) 120. copper 124. nickel fluoride
Primary Zirconium and Hafnium	119. chromium (total) 121. cyanide (total) 122. lead 124. nickel ammonia (as N)

*Regulated by PSNS only.

+Regulated by PSES only.

THIS PAGE INTENTIONALLY LEFT BLANK

SECTION XIII

BEST CONVENTIONAL POLLUTANT CONTROL TECHNOLOGY

EPA is not promulgating best conventional pollutant control technology (BCT) for the nonferrous metals manufacturing category at this time.

THIS PAGE INTENTIONALLY LEFT BLANK

SECTION XIV

ACKNOWLEDGMENTS

The nonferrous metals manufacturing project has been ongoing as a regulation development project since the Consent Agreement of 1976 required EPA to re-study and expand the regulation of this industry category. During this eleven year period many persons have contributed in a meaningful way toward the successful completion of the project. This section is intended to provide some recognition to those who have labored in behalf of this regulation development effort.

Much of the sampling, analysis, data compilation and draft manuscript preparation has been conducted by contractors for the EPA. The initial contractor in this effort was Sverdrup and Parcel and Associates under Contact No. 68-01-4409. Technical personnel of this contractor who worked on the project included: Mr. Donald Washington, Project Manager, Mr. Garry Aronberg, Ms. Claudia O'Leary, Mr. Antony Tawa, Mr. Charles Amelotti and Mr. Jeff Carlton. The second and final contractor in this effort was Radian Corporation under Contracts N. 68-01-6529, 68-01-6999 and 68-03-3411. Technical personnel of this contractor who worked on the project included: Mr. James Sherman, Program Manager, Mr. Mark Hereth, Project Director, Mr. Ron Dickson, Mr. John Vidumsky, Mr. Richard Weisman, Mr. Tom Grome, Mr. Marc Papai, Ms. Lori Stoll, Mr. John Collins, Mr. Mike Zapkin, Mr. Andrew Oven and Ms. Diane Neuhaus. Acknowledgment and appreciation is also made to the Radian secretarial staff, Ms. Nancy Johnson, Ms. Sandra Zapkin and Ms. Daphne Phillips for their tireless efforts.

This regulation development project has been under the direction of Mr. Ernst P. Hall, Chief of the Metals Industry Branch, Industrial Technology Division of EPA. Technical Project Officers for this project were (in order of succession) Ms. Patricia Williams, Mr. James Berlow, Ms. Maria Irizarry, and Ms. Eleanor Zimmerman, with assistant project Officers Mr. Geoffery Grubbs and Mr. Stuart Colton. The final review and editing of this document has been under the immediate direction of Mr. Hall.

Special note is made of the contribution of the word processing staff of the Industrial Technology Division, Ms. Kaye Starr, Ms. Nancy Zubric, Ms. Pearl Smith, Ms. Carol Swann and Ms. Glenda Nesby and a special commendation is given to Ms. Smith for her tireless efforts in producing the final drafts and camera ready copy of the entire document.

The cooperation of the Aluminum Association, American Mining Congress, Aluminum Recycling Association, Tantalum Producers Association and Secondary Lead Smelters Association along with their technical committees and individual companies that supplied information and whose plants were sampled is gratefully acknowledged.

THIS PAGE INTENTIONALLY LEFT BLANK

SECTION XV

REFERENCES

1. Sampling and Analysis Procedures for Screening of Industrial Effluents for Priority Pollutants, USEPA Environmental Monitoring and Support Laboratory, Cincinnati, OH 45268 (March, 1977, revised April, 1977).
2. "Mineral Facts and Problems," Bureau of Mines Bulletin 667, Washington, D.C., Department of the Interior (1975).
3. Development Document for Effluent Limitations Guidelines and New Source Performance Standards for the Primary Aluminum Smelting Subcategory, EPA-440/1-74-019d. Environmental Protection Agency (March, 1974).
4. Development Document for Effluent Limitations Guidelines and New Source Performance Standards for the Secondary Aluminum Subcategory, EPA-400/1-74-019e, Environmental Protection Agency (March, 1974).
5. Development Document for Interim Final Effluent Limitations Guidelines and Proposed New Source Performance Standards for the Primary Copper Smelting Subcategory and Primary Copper Refining Subcategory, EPA-440/1-75/032b, Environmental Protection Agency (February, 1975).
6. Development Document for Interim Final Effluent Limitations Guidelines and Proposed New Source Performance Standards for the Secondary Copper Subcategory, EPA-440/1-75/032c, Environmental Protection Agency (February, 1975).
7. Development Document for Interim Final Effluent Limitations Guidelines and Proposed New Source Performance Standards for the Lead Segment, EPA-440/1-75/032a, Environmental Protection Agency (February, 1975).
8. Development Document for Interim Final Effluent Limitations Guidelines and Proposed New Source Performance Standards for the Zinc Segment, EPA-440/1-75/032, Environmental Protection Agency (February, 1975).
9. Draft Development Document for Effluent Limitations Guidelines and New Source Performance Standards for the Miscellaneous Nonferrous Metals Segment, EPA-440/1-76/067, Environmental Protection Agency (March, 1977).
10. "National Resources Defense Council v. Train", Environmental Reporter - Cases 8 ERC 2120 (1976).

11. Development Document for Effluent Limitations Guidelines and New Source Performance Standards for the Bauxite Refining Industry, EPA-440/1-74/019c, Environmental Protection Agency (March, 1974).
12. Pound, C. E. and Crites, R. W., "Land Treatment of Municipal Wastewater Effluents, Design Factors - Part 1," Paper presented at USEPA Technology Transfer Seminars (1975).
13. Wilson, Phillip R., Brush Wellman, Inc., Elmore, OH, Personal Communication (August, 1978).
14. Description of the Beryllium Production Processes at the Brush Wellman, Inc. Plant in Elmore, OH, Brush Wellman, Inc. (1977). (Photocopy).
15. Phillips, A. J., "The World's Most Complex Metallurgy (Copper, Lead and Zinc)," Transactions to the Metallurgical Society of AIME, 224, 657 (August, 1976).
16. Schack, C. H. and Clemmons, B. H., "Review and Evaluation of Silver-Production Techniques," Information Circular 8266, United States Department of the Interior, Bureau of Mines (March, 1965).
17. Technical Study Report: BATEA-NSPS-PSES-PSNS-Textile Mills Point Source Category, Report submitted to EPA-Effluent Guidelines Division by Sverdrup & Parcel and Associates, Inc. (November, 1978).
18. The Merck Index, 8th edition, Merck & Co., Inc., Rahway, NJ (1968).
19. Rose, A. and Rose, E., The Condensed Chemical Dictionary, 6th ed., Reinhold Publishing Company, New York (1961).
20. McKee, J. E. and Wolf, H. W. (eds.), Water Quality Criteria, 2nd edition, California State Water Resources Control Board (1963).
21. Quinby-Hunt, M. S., "Monitoring Metals in Water," American Chemistry (December, 1978), pp. 17-37.
22. Fassel, V. A. and Kniseley, R. N., "Inductively Coupled Plasma - Optical Emission Spectroscopy," Analytical Chemistry, 46,13 (1974)
23. Study of Selected Pollutant Parameters in Publicly Owned Treatment Works, Draft report submitted to EPA-Effluent Guidelines Division by Sverdrup & Parcel and Associates, Inc. (February, 1977).
24. Schwartz, H. G. and Buzzell, J. C., The Impact of Toxic Pollutants on Municipal Wastewater Systems, EPA Technology Transfer, Joint Municipal/Industrial Seminar on Pretreatment of Industrial Wastes, Dallas, TX (July, 1978).

25. Class notes and research compiled for graduate class, Autumn Qtr., 1976-77 School year at Montana State University by G. A. Murgel.
26. Gough, P. and Shocklette, H. T., "Toxicity of Selected Elements to Plants, Animals and Man--An Outline," Geochemical Survey of the Western Energy Regions, Third Annual Progress Report, July, 1976, US Geological Survey Open File Report 76-729, Department of the Interior, Denver (1976).
27. Second Interim Report - Textile Industry BATEA-NSPS-PSES-PSNS Study, report submitted to EPA-Effluent Guidelines Division by Sverdrup & Parcel and Associates, Inc. (June, 1978).
28. Proposed Criteria for Water Quality, Vol. 1, Environmental Protection Agency (October, 1973) citing Vanselow, A. P., "Nickel, in Diagnostic Criteria for Plants and Soils," H. D. Chapman, ed., University of California, Division of Agricultural Science, Berkeley, pp. 302-309 (1966).
29. Morrison, R. T. and Boyd, R. N., Organic Chemistry, 3rd ed., Allyn and Bacon, Inc., Boston (1973).
30. McKee, J. E. and Woll, H. W. (eds), Water Quality Criteria, 2nd edition, California State Water Resources Control Board (1963) citing Browning, E., "Toxicity of Industrial Metals, Butterworth, London, England (1961).
31. citing Stokinger, H. E. and Woodward, R. L., "Toxicologic Methods for Establishing Drinking Water Standards," Journal AWWA, 50, 515 (1958).
32. citing Waldichuk, M., "Sedimentation of Radioactive Wastes in the Sea," Fisheries Research Board of Canada, Circular No. 59 (January, 1961).
33. citing "Quality Criteria for Water," U.S. Environmental Protection Agency, Washington, D.C., Reference No. 440/9-76-023.
34. Bronstein, M. A., Privitera, E. L., and Terlecky, P. M., Jr., "Analysis of Selected Wastewater Samples of Chrysotile Asbestos and Total Fiber Counts - Nonferrous Metals Point Source Category," Calspan Advanced Technology Center, Report No. ND-5782-M-19 for USEPA, Effluent Guidelines Division (November 1, 1978).
35. Hallenbeck, W. H. and Hesse, C. S., "A Review of the Health Effects of Ingested Asbestos," Review of Environmental Health, 2, 3, 157 (1977).
36. McKee, J. E. and Wolf, H. W. (eds), Water quality Criteria, 2nd edition, California State Water Resources Control Board, (1963) citing The Merck Index, 7th ed., Merck & Co., Inc., Rahway, NJ (1960).

37. citing Pomelee, C. S., "Toxicity of Beryllium," Sewage and Industrial Wastes, 25, 1424 (1953).
38. citing Rothstein, "Toxicology of the Minor Metals," University of Rochester, AEC Project, UR-262 (June 5, 1953).
39. citing Truhout, R. and Boudene, C., "Enquiries Into the Facts of Cadmium in the Body During Poisoning: Of Special Interest to Industrial Medicine," Archiv. Hig. Roda 5, 19 (1954); AMA Archives of Industrial Health 11, 179 (February, 1955).
40. citing Fairhall, L. T., "Toxic Contaminants of Drinking Water," Journal New England Water Works Association, 55, 400 (1941).
41. citing Ohio River Valley Water Sanitation Commission, "Report on the Physiological Effects of Copper on Man," The Kettering Laboratory, College of Medicine, University of Cincinnati, Cincinnati, OH (January 28, 1953).
42. citing "Copper and the Human Organism," Journal American Water Works Association, 21, 262 (1929).
43. citing Taylor, E. W., "The Examination of Waters and Water Supplies," P. Blakiston's Son and Co. (1949).
44. citing "Water Quality and Treatment," 2nd ed., AWWA (1950).
45. citing Hale, F. E., "Relation to Copper and Brass Pipe to Health," Water Works Eng., 95, 240, 84, 139, 187 (1942).
46. citing "Drinking Water Standards," Title 42 - Public Health Chapter 1 - Public Health Service, Department to Health, Education, and Welfare; Part 72 - Interstate Quarantine Federal Register 2152 (March 6, 1962).
47. citing Derby, R. L., Hopkins, O. C., Gullans, O., Baylis, J. R., Bean, E. L., and Malony, F., "Water Quality Standards," Journal American Water Works Association, 52, 1159 (September, 1960).
48. McKee, J. E. and Wolf, H. W., (eds.), Water Quality Criteria, 2nd edition, California State Water Resources Control Board, (1963) citing Klein, L., "Aspects of River Pollution," Butterworth Scientific Publications, London and Academic Press, Inc., New York (1957).
49. citing Fuchess, H., Bruns, H., and Haupt, H., "Danger of Lead Poisoning From Water Supplies," Theo. Steinkopff (Dresden) (1938); Journal American Water Works Association, 30, 1425 (1938).
50. citing "Ohio River Valley Water Sanitation Commission, Subcommittee on Toxicities, Metal Finishing Industries Action

Committee," Report No. 3 (1950).

51. Pickering, Q. H. and Henderson, C., "The Acute Toxicity of Some Heavy Metals to Different Species of Warm Water Fish," *Intnat. J. Air-Water Pollution*, 10: 453-463 (1966).

52. Murdock, H. R. *Industrial Wastes*, "Ind. Eng. Chem. 99A-102A (1953).

53. Calabrese, A., et. al., "The Toxicity of Heavy Metals of Embryos of the American Oyster, *Crassostrea Virginica*," *Marine Biology* 38: 162-166 (1973).

54. citing Russell, F. C., "Minerals in Pasture, Deficiencies and Excesses in Relation to Animal Health," *Imperial Bureau of Animal Nutrition, Aberdeen, Scotland, Tech. Communication 15 (1944).*

55. citing Hurd-Kaner, A., "Selenium Absorption by Plants and their Resulting Toxicity to Animals," *Smithsonian Inst. Ann. Rept.*, p. 289 (1934-35).

56. citing Byers, H. G., "Selenium Occurrence in Certain Soils in the United States with a Discussion of Related Topics," *U.S. Department of Agr. Tech. Bull. No. 582 (August, 1935).*

57. citing Fairhall, L. T., "Toxic Contaminants of Drinking Water," *Journal New England Water Works Association*, 55, 400 (1941).

58. citing Smith, M. I., Franke, K. W., and Westfall, B. B., "Survey to Determine the Possibility of Selenium Detoxification in the Rural Population Living on Seleniferous Soil," *Public Health Repts.* 51, 1496 (1936).

59. citing Kehoe, R. A., Cholak, J., and Largent, E. J., "The Hygienic Significance of the Contamination of Water with Certain Mineral Constituents," *Journal American Water Works Association*, 36, 645 (1944).

60. citing Schwarz, K., "Effects of Trace Amounts of Selenium," *Proc. Conf. Physical. Effects of Water Quality, U.S.P.H.S.*, p. 79 (September, 1960).

61. *Water Quality Criteria of 1972. NAS Report.*

62. *US Department of Agriculture, Agricultural Research Science, Consumer and Food Economics Research Division, "Food Consumption of Households in the United States" (Spring, 1965), Preliminary Report, Agricultural Research Service, Washington, D.C.*

63. Hill, W. R. and Pillsburg" D. M., "Argyria Investigation - Toxicity Properties of Silver," *American Silver Producers Research Project Report, Appendix 11.*

64. citing Brown, A. W. A., "Insect Control by Chemicals," John Wiley and Sons (1951).
65. Lougis, P., "The Physiological Effect of Zinc in Seawater," Comptes Rendu, Paris, 253:740-741 (1961).
66. Wisely, B. and Blick, R. A., "Mortality of Marine Invertebrate Larvae in Mercury, Copper and Zinc Solutions," Aust. J. of Mar. Fresh. Res., 18:63-72 (1967).
67. Clarke, G. L., "Poisoning and Recovery in Barnacles and Mussels," Biol. Bull., 93:73-91 (1947).
68. Foreman, C. T., "Food Safety and the Consumer," EPA Jour. 4, 10, 16 (November/December, 1978).
69. Marnahan, S. E., Environmental Chemistry, 2nd ed., Willard Grant Press, Boston (1975).
70. Methods for Chemical Analysis of Water and Wastes, Environmental Monitoring and Support Laboratory, EPA-625/6-74-003a USEPA, Cincinnati, OH (1976).
71. Krocta, H. and Lucas, R. L., "Information Required for the Selection and Performance Evaluation of Wet Scrubbers," Journal of Pollution Control Association, 22, 6, 459.
72. Pourbaix, M., Atlas of Electrochemical Equilibria in Aqueous Solutions, Pergamon Press, New York (1966) cited in Development Document for Interim Final Effluent Limitations Guidelines and Proposed New Source Performance Standards for the Primary Copper Smelting Subcategory and Primary Copper Refining Subcategory, EPA-440/1-75/032b, Environmental Protection Agency (February, 1975).
73. Draft Development Document for Effluent Limitations Guidelines and New Source Performance Standards for the Miscellaneous Nonferrous Metals Segment, EPA-440/1-76/067, Environmental Protection Agency (March, 1977) citing Miller, D. G., "Fluoride Precipitation in Metal Finishing Waste Effluent," Water-1974:I. Industrial Waste Treatment, American Institute of Chemical Engineers Symposium Series, 70, 144 (1974).
74. Parker and Fong, "Fluoride Removal: Technology and Cost Estimates," Industrial Wastes (November/December, 1975).
75. Rohrer, L., "Lime, Calcium Chloride Beat Fluoride Wastewater," Water and Wastes Engineering (November, 1974), p. 66 cited in Draft Development Document for Effluent Limitations Guidelines and New Source Performance Standards for the Miscellaneous Nonferrous Metals Segment, EPA-440/1-76/067, Environmental Protection Agency (March, 1977).
76. Zabben, W. and Jewett, H. W., "The Treatment of Fluoride

Wastes," Proceedings of 22nd Industrial Waste Conference, Purdue University (May 2-4, 1967), pp. 706-716.

77. Manual of Treatment Techniques for Meeting the Interim Primary Drinking Water Regulations, EPA-600/8-77-005, Environmental Protection Agency (April, 1978).

78. Patterson, J.W. "Technology and Economics of Industrial Pollution Abatement," IIEQ Document #76/22 Project #20.070A (1976).

79. Maruyama, T., Hannah, S. A., and Cohen, J. M., "Metal Removal by Chemical Treatment Processes," Journal Water Pollution Control Federation, 47, 5, 962.

80. Culp, G. L. and Culp, R. L., New Concepts in Water Purification, (Van Nostrand, Reinhold and Company, New York (1974), pp. 222-224.

81. Jenkins, S. N., Knight, D. G., and Humphreys, R. E., "The Solubility of Heavy Metal Hydroxides in Water, Sewage, and Sewage Sludge, I. The Solubility of Some Metal Hydroxides," International Journal of Air and Water Pollution, 8, 537 (1964).

82. Sittig, M., Pollutant Removal Handbook. Noyes Data Corp., Park Ridge, NJ (1973).

83. Link, W. E. and Rabosky, J. G., "Fluoride Removal from Wastewater Employing Calcium Precipitation and Iron Salt Coagulation," Proceedings of the 31st Industrial Waste Conference, Purdue University, pp. 485-500 (1976).

84. Beychak, M. R., Aqueous Wastes from Petroleum and Petrochemical Plants, John Wiley and Sons (1967) cited in Draft Development Document for Effluent Limitations Guidelines and New Source Performance Standards for the Miscellaneous Nonferrous Metals Segment, EPA-440/1-76-067, Environmental Protection Agency (March, 1977).

85. "Stripping, Extraction, Adsorption, and Ion Exchange," Manual on Disposal of Refinery Wastes - Liquid Wastes, American Petroleum Institute, Washington, D. C. (1973) cited by Draft Development Document for Effluent Limitations Guidelines and New Source Performance Standards for the Miscellaneous Nonferrous Metals Segment, EPA-440/1-76/067, Environmental Protection Agency (March, 1977).

86. Grantz, R. G., "Stripper Performance Tied to NH₃ Fixation," Oil and Gas Journal, 73, 24, 80 (1975) cited by Draft Development Document for Effluent Limitations Guidelines and New Source Performance Standards for the Miscellaneous Nonferrous Metals Segment, EPA-440/1-76/067, Environmental Protection Agency (March, 1977).

87. Wrek, W. J. and Snow, R. H., "Design to Cross Flow Cooling

Towers and Ammonia Stripping Towers," Industrial Engineering Process Design Development, 11, 3 (1972) cited by Draft Development Document for Effluent Limitations Guidelines and New Source Performance Standards for the Miscellaneous Metals Segment, EPA-440/1-76-067, Environmental Protection Agency (March, 1977).

88. Mioderszewski, D., "Ammonia Removal - What's Best," Water and Wastes Engineering (July, 1975) cited by Draft Development Document for Effluent Limitations Guidelines and New Source Performance Standards for the Miscellaneous Metals Segment, EPA-440/1-76-067, Environmental Protection Agency (March, 1977).

89. Schlauch, R. M., and Epstein, A. C., Treatment to Metal Finishing Wastes by Sulfide Precipitation, EPA 600/2-77-049.

90. Coleman, R. T., Colley, D. J., Klausmeier, R. F., Malish, D. A., Meserole, N. P., Micheletti, W. C., and Schwitzgebel, K., Draft Copy Treatment Methods for Acidic Wastewater Containing Potentially Toxic Metal Compounds, Report by Radian Corporation, Austin, TX, submitted to USEPA Industrial Environmental Research Laboratory, Cincinnati, OH (1978).

91. Bettler, C. R., "Lime Neutralization of Low-Acidity Wastewater," Proceedings of 32nd Industrial Waste Conference, Purdue University (1977), p. 830.

92. Permutt Co., Inc., Proceedings of seminar on metal waste treatment featuring the Sulfex process, Paramus, NJ, undated.

93. Larson, H. P., Shou, K. P., Ross, L. W., "Chemical Treatment of Metal Bearing Mine Drainage," Journal Water Pollution Control Federation, 45, 8, 1682 (1974) cited by Coleman, R. T., et. al., Draft Copy Treatment Methods for Acidic Wastewater Containing Potentially Toxic Metal Compounds, Report by Radian Corporation, Austin, TX, submitted to USEPA Industrial Environmental Research Laboratory, Cincinnati, OH (1978).

94. Murao, K. and Sei, N., "Recovery of Heavy Metals from the Wastewater of Sulfuric Acid Process in Aho Smelter," Proceedings of Joint MMIJ AIME Meeting on World Mining and Metallurgical Technology, Denver, September, 1976, Volume 2, pp. 808-16 (1976) cited by Coleman, R. T., et. al., Draft Copy Treatment Methods for Acidic Wastewater Containing Potentially Toxic Metal Compounds, Report by Radian Corporation, Austin, TX, submitted to USEPA Industrial Environmental Research Laboratory, Cincinnati, OH (1978).

95. LaPerle, R. L., "Removal of Metals from Photographic Effluent by Sodium Sulfide Precipitation," Journal Appl. Photogr. Eng. 2, 134, (1976) cited by Coleman, R. T., et. al., Draft Copy Treatment Methods for Acidic Wastewater Containing Potentially Toxic Metal Compounds, Report by Radian Corporation, Austin, TX, submitted to USEPA Industrial Environmental Research Laboratory, Cincinnati, OH (1978).

96. Scott, M. (Senior Marketing Specialist, Permutit Company), Private communications with R. Klausmeier (November, 1977) cited by Coleman, R. T., et. al., Draft Copy Treatment Methods for Acidic Wastewater Containing Potentially Toxic Metal Compounds, Report by Radian Corporation, Austin, TX, submitted to USEPA Industrial Environmental Research Laboratory, Cincinnati, OH (1978).

97. Development Document for Interim Final and Proposed Effluent Limitations Guidelines and New Source Performance Standards for the Ore Mining and Dressing Industry, EPA-440/1-75-061, Environmental Protection Agency (1975) cited by Coleman, R. T., et. al., Draft Copy Treatment Methods for Acidic Wastewater Containing Potentially Toxic Metal Compounds, Report by Radian Corporation, Austin, TX, submitted to USEPA Industrial Environmental Research Laboratory, Cincinnati, OH (1978).

98. Coleman, R. T. and Malish, D. A., Trip Report to Paul Bergoe and Son, Boliden Aktiebolag and Outokumpu as part to EPA Contract 68-02-2608, Radian Corporation (November, 1977) cited by Coleman, R. T., et. al., Draft Copy Treatment Methods for Acidic Wastewater Containing Potentially Toxic Metal Compounds, Report by Radian Corporation, Austin, TX, submitted to USEPA Industrial Environmental Research Laboratory, Cincinnati, OH (1978).

99. Maltson, M. E., "Membrane Desalting Gets Big Push," Water and Wastes Engineering (April, 1975), p. 35.

100. Cruver, J. E., "Reverse Osmosis for Water Reuse," Gulf Environmental System (June, 1973).

101. "Water Renovation of Municipal Effluents by Reverse Osmosis," Gulf Oil Corporation, San Diego (February, 1972).

102. Spatz, D. D., "Methods of Water Purification," Presented to the American Association of Nephrology Nurses and Technicians at the ASAIO AANNT Joint Conference, Seattle, Washington (April, 1972).

103. Donnelly, R. G., Goldsmith, R. L., McNulty, K. J., Grant, D. C., and Tan, M., Treatment to Electroplating Wastes by Reverse Osmosis, EPA-600/2-76-261, Environmental Protection Agency (September, 1976).

104. Rook, J. J., "Haloforms in Drinking Water," Journal American Water Works Association, 68:3:168 (1976).

105. Rook, J. J., "Formation to Haloforms During Chlorination of Natural Waters," Journal Water Treatment Examination, 23:234 (1974).

106. Trussell, R. R. and Umphres, M. D., "The Formation of Trihalomethanes," Journal American Water Works Association 70:11:604 (1978).

107. Nebel, C., Goltschlintg, R. D., Holmes, J. L., and Unangst, P. C., "Ozone Oxidation of Phenolic Effluents," Proceedings of the 31st Industrial Waste Conference, Purdue University (1976), pp. 940-951.
108. Rosen, H. M., "Wastewater Ozonation: a Process Whose Time Has Come," Civil Engineering, 47, 11, 65 (1976).
109. Hardisty, D. M. and Rosen, H. M., "Industrial Wastewater Ozonation," Proceedings of the 32nd Industrial Waste Conference, Purdue University (1976), pp. 940-951.
110. Traces of Heavy Metals in Water Removal Processes and Monitoring, EPA-902/9-74-D01, Environmental Protection Agency (November, 1973).
111. Symons, J. M., "Interim Treatment Guide for Controlling Organic Contaminants in Drinking Water Using Granular Activated Carbon," Water Supply Research Division, Municipal Environmental Research Laboratory, Office of Research and Development, USEPA, Cincinnati, OH (January, 1978).
112. McCreary, J. J. and V. L. Snoeyink, "Granular Activated Carbon in Water Treatment," Journal American Water Works Association, 69, 8, 437 (1977).
113. Grieves, C. G. and Stevenson, M. K., "Activated Carbon Improves Effluents," Industrial Wastes (July/August, 1977), pp. 30-35.
114. Beebe, R. L. and Stevens, J. I., "Activated Carbon System for Wastewater Renovation," Water and Wastes Engineering (January, 1967), pp. 43-45.
115. Culp, G. L. and Shuckrow, A. J., "What lies ahead for PAC," Water and Wastes Engineering (February, 1977), pp. 67-72, 74.
116. Savinelli, E. A. and Black, A. P., "Defluoridation of Water With Activated Alumina," Journal American Water Works Association, 50, 1, 33 (1958).
117. Paulson, E. G., "Reducing Fluoride in Industrial Wastewater," Chemical Engineering, Deskbook Issue (October 17, 1977).
118. Bishop, P. L. and Sansovey, G., "Fluoride Removal from Drinking Water by Fluidized Activated Alumina Adsorption," Journal American Water Works Association, 70, 10, 554 (1978).
119. Harmon, J. A. and Kalichman, S. G., "Defluoridation of Drinking Water in Southern California," Journal American Water Works Association, 57:2:245 (1965).
120. Maier, F. J., "Partial Defluoridation of Water," Public Works, 91:90 (1960).

121. Bellack, E., "Arsenic Removal from Potable Water," Journal American Water Works Association, 63, 7 (1971).
122. Gupta, S. K. and Chen, K. Y., "Arsenic Removal by Adsorption," Journal Water Pollution Control Association (March, 1978), pp. 493-506.
123. Johnson, D. E. L., "Reverse Osmosis Recycling System for Government Arsenal," American Metal Market (July 31, 1973) cited in Draft Development Document for Effluent Limitations Guidelines and New Source Performance Standards for the Miscellaneous Nonferrous Metals Segment, EPA-440/1-76-067, Environmental Protection Agency (March, 1977).
124. Nachod, F. C. and Schubert, J., Ion Exchange Technology, Academic Press, Inc. (1956).
125. Volkert, David, and Associates, "Monograph on the Effectiveness and Cost of Water Treatment Processes for the Removal of Specific Contaminants," EPA 68-01-1833, Office of Air and Water (1974) cited by Contaminants Associated with Direct and Indirect Reuse of Municipal Wastewater, EPA-600/1-78-019 (March, 1978).
126. Clark, J. W., Viessman, W., Jr., and Hammer, M., Water Supply and Pollution Control, (3rd ed.) IEP, New York (1977).
127. AWARE (Associated Water and Air Resources Engineers, Inc.), Analysis to National Industrial Water Pollution Control Costs," (May 21, 1973).
128. AWARE, "Alternatives for Managing Wastewater in the Three Rivers Watershed Area," (October, 1972).
129. Bechtel, "A Guide to the Selection of Cost-Effective Wastewater Treatment Systems," EPA 430/9-75-002 (July, 1975).
130. Smith R., "Cost of Conventional and Advanced Treatment of Wastewater," Journal Water Pollution Control Federation, 40, 9, 1546 (1968).
131. Icarus, "Capital and Operating Costs of Pollution Control Equipment Modules," Vols. I and II, EPA-R5-73-023a & b (July, 1973).
132. Monti, R. P. and Silberman, P. T., "Wastewater System Alternatives: What Are They . . . and What Cost," Water and Waste Engineering (May, 1974), p. 40.
133. Process Design Manual for Removal of Suspended Solids, EPA-625/175-003a (January, 1975).
134. Process Design Manual for Carbon Adsorption, EPA 625/1-71-002a (October, 1973).
135. Grits, G. J., "Economic Factors in Water Treatment,"

Industrial Water Engineering (November, 1971), p. 22.

136. Barnard, J. L. and Eckenfelder, W. W., Jr., "Treatment Cost Relationships for Industrial Waste Treatment, Environmental and Water Resources Engineering, Vanderbilt University (1971).

137. Grits, G. J. and Glover, G. G., "Cooling Blowdown in Cooling Towers," Water and Wastes Engineering (April, 1975), p. 45.

138. Kremen, S. S., "The True Cost of Reverse Osmosis," Industrial Wastes (November/December, 1973), p. 24.

139. Cruver, J. E. and Sleigh, J. H., "Reverse Osmosis - The Emerging Answer to Seawater Desalination," Industrial Water Engineering (June/July, 1976), p. 9.

140. Doud, D. H., "Field Experience with Five Reverse Osmosis Plants," Water and Sewage Works (June, 1976), p. 96.

141. Lacey, R. E. and Loed, S., (eds.), "Industrial Processing with Membranes," in The Cost of Reverse Osmosis, John Wiley and Sons (1972).

142. Disposal of Brines Produced in Renovation of Industrial Wastewater, FWPA Contract #14-12-492 (May, 1970).

143. Process Design Manual for Sludge Treatment and Disposal, EPA 625/1-74-006 (October, 1974).

144. Black & Veatch, "Estimating Cost and Manpower Requirements for Conventional Wastewater Treatment Facilities," EPA Contract #14-12-462 (October, 1971).

145. Osmonics, Inc., "Reverse Osmosis and Ultrafiltration Systems Bulletin No. G7606," (1978).

146. Buckley, J. D., "Reverse Osmosis Moving from Theory to Practice," From Fluid Systems Div., UOP, Inc. (Reprint from Consulting Engineer), 45, 5, 55 (1975).

147. Process Design Manual for Nitrogen Control, EPA-Technology Transfer (October, 1975).

148. Rizzo and Shepherd, "Treating Industrial Wastewater with Activated Carbon," Chemical Engineering (January 3, 1977).

149. Richardson, "1978-79 Process Equipment," Vol. 4 of Richardson Rapid System.

150. Thiansky, D. P., "Historical Development of Water Pollution Control Cost Functions," Journal Water Pollution Control Federation, 46, 5, 813 (1974).

151. Zimmerman, O. T., "Wastewater Treatment," Cost Engineering

(October, 1971), p. 11.

152. Watson, I. C., (Control Research, Inc.) "Manual for Calculation of Conventional Water Treatment Costs," Office of Saline Water (March, 1972).

153. Culp, R. L., Wesner, G. M., Culp, G. L., Handbook of Advanced Wastewater Treatment, McGraw Hill (1978).

154. Dynatech R/D Company, A Survey of Alternate Methods for Cooling Condenser Discharge Water Large-Scale Heat Rejection Equipment, EPA Project No. 16130 DHS (July, 1969).

155. Development Document for Steam Electric Power Generating, EPA 440/1-73/029 (March, 1974).

156. "Cooling Towers - Special Report," Industrial Water Engineering (May, 1970).

157. AFL Industries, Inc., "Product Bulletin #12-05.B1 (Shelter Uses)," Chicago, IL (December 29, 1977).

158. Fisher Scientific Co., Catalog 77 (1977).

159. Isco, Inc., Purchase Order Form, Wastewater Samplers (1977).

160. Dames & Moore, Construction Cost for Municipal Wastewater Treatment Plants: 1973-1977, EPA-430/9-77-013, MCD-37 (January, 1978).

161. Metcalf & Eddy, Inc., Wastewater Engineering: Collection, Treatment, Disposal, McGraw-Hill, New York (1972).

162. Obert, E. F. and Young, R. L., Elements of Thermodynamics and Heat Transfer, McGraw-Hill (1962), p. 270.

163. Paulson, E. G., "How to Get Rid of Toxic Organics," Chemical Engineering, Deskbook Issue (October 17, 1977), pp. 21-27.

164. CH2-M-Hill, "Estimating Staffing for Municipal Wastewater Treatment Facilities," EPA #68-01-0328 (March, 1973).

165. "EPA Indexes Reflect Easing Costs," Engineering News Record (December 23, 1976), p. 87.

166. Chemical Marketing Reporter, Vol. 210, 10-26 (December 6 and December 20, 1976).

167. Smith, J. E., "Inventory of Energy Use in Wastewater Sludge Treatment and Disposal," Industrial Water Engineering (July/August, 1977).

168. Jones, J. L., Bomberger, D. C., Jr., and Lewis, F. M.,

"Energy Usage and Recovery in Sludge Disposal, Parts 1 & 2, "Water and Sewage Works (July and August, 1977), pp. 44-47 and 42-46.

169. Hagen, R. M. and Roberts, E. B., "Energy Requirements for Wastewater Treatment, Part 2," Water and Sewage Works (December, 1976), p. 52.

170. Banersi, S. K. and O'Conner, J. T., "Designing More Energy Efficient Wastewater Treatment Plants," Civil Engineering (September, 1977), p. 76.

171. "Electrical Power Consumption for Municipal Wastewater Treatment," EPA-R2-73-281 (1973).

172. Hillmer, T. J., Jr., "Economics of Transporting Wastewater Sludge," Public Works (September, 1977), p. 110.

173. Ettlich, W. F., "Economics of Transport Methods of Sludge." Proceedings of the Third National Conference on Sludge Management, Disposal and Utilization (December 14-16, 1976), pp. 7-14.

174. NUS/Rice Laboratory, "Sampling Prices," Pittsburgh, PA (1978).

175. WARF Instruments, Inc., "Pricing Lists and Policies," Madison, WI (June, 15, 1973).

176. Orlando Laboratories, Inc., "Service Brochure and Fee Schedule #16," Orlando, FL (January 1, 1978).

177. St. Louis Testing Laboratory, "Water and Wastewater Analysis - Fee Schedule," St. Louis, MO (August, 1976).

178. Ecology Audits, Inc., "Laboratory Services - Individual Component Analysis," Dallas, TX (August, 1976).

179. Laclede Gas Company, (Lab Div.), "Laboratory Pricing Schedule," St. Louis, MO (August, 1977).

180. Industrial Testing Lab, Inc., "Price List," St. Louis, MO (October, 1975).

181. Luther, P. A., Kennedy, D. C., and Edgerley, E., Jr. "Treatability and Functional Design of a Physical-Chemical Wastewater Treatment System for a Printing and Photodeveloping Plant," 31st Purdue Industrial Waste Conference, pp. 876-884 (1976).

182. Hindin, E. and Bennett, P. J., "Water Reclamation by Reverse Osmosis," Water and Sewage Works, 116, 2, 66 (February, 1969).

183. Cruver, J. E. and Nusbaum, I., "Application of Reverse Osmosis to Wastewater Treatment," Journal Water Pollution Control Association, 476, 2, 301 (February, 1974).

184. Cruver, J. E., "Reverse Osmosis - Where It Stands Today," Water and Sewage Works, 120, 10, 74 (October, 1973).
185. Vanderborght, B. M. and Vangrieken, R. E., "Enrichment of Trace Metals by Adsorption on Activated Carbon," Analytic Chemistry, 49, 2, 311 (February, 1977).
186. Hannah, S. A., "Jelus, by Physical and Chemical Treatment Processes," Journal Water Pollution Control Federation, 50, 11, 2297 (1978).
187. Argo, D. G. and Culp, G. L., "Heavy Metals Removed in Wastewater Treatment Processes - Parts 1 and 2," Water and Sewage Works, August, 1972, pp. 62-65, and September, 1972, pp. 128-132.
188. Hager, D. G., "Industrial Wastewater Treatment by Granular Activated Carbon," Industrial Water Engineering, pp. 14-28 (January/February, 1974) 189. Rohrer, K. L., "Chemical Precipitants for Lead-Bearing Wastewaters," Industrial Water Engineering, 12, 3 13 (1975).
189. Brody, M. A. and Lumpkins, R. J., "Performance of Dual-Media Filters," Chemical Engineering Progress (April, 1977).
190. Bernardin, F. E., "Cyanide Detoxification Using Absorption and Catalytic Oxidation," Journal Water Pollution Control Federation, 45, 2 (February, 1973).
191. Russel, D. L., "PCB's: The Problem Surrounding Us and What Must be Done," Pollution Engineering (August, 1977).
192. Chriswell, C. D., et. al., "Comparison of Macroreticular Resin and Activated Carbon as Sorbents," Journal American Water Works Association (December, 1977).
193. Gehm, H. W. and Bregman, J. I., Handbook of Water Resources and Pollution Control, Van Nostrand Reinhold Company (1976).
194. Considine, Douglas M., Energy Technology Handbook, McGraw-Hill Book Company, New York, c.1977, pp. 5-173-5-181.
195. Absalom, Sandra T., Boron, U.S. Dept. of the Interior, Bureau of Mines, Washington, D.C., May, 1979.
196. Rathen, John A., Antimony, U.S. Dept. to the Interior, Bureau of Mines, Washington, D.C., June, 1979.
197. Harris, Keith L., Cesium, U.S. Dept. of the Interior, Bureau of Mines, Washington, D.C., May, 1979.

THIS PAGE INTENTIONALLY LEFT BLANK

SECTION XVI

GLOSSARY

This section is an alphabetical listing to technical terms (with definitions) used in this document which may not be familiar to the reader.

4-AAP Colorimetric Method

An analytical method for total phenols and total phenolic compounds that involves reaction with the color developing agent 4-aminoantipyrine.

Acidity

The quantitative capacity to aqueous solutions to react with hydroxyl ions. It is measured by titration with a standard solution to a base to a specified end point, and is usually expressed as milligrams per liter to calcium carbonate.

The Act

The Federal Water Pollution Control Act Amendments of 1972 as amended by the Clean Water Act to 1977 (PL 92-500).

Amortization

The allocation of a cost or account according to a specified schedule, based on the principal, interest and period of cost allocation.

Analytical Quantification Level

The minimum concentration at which quantification of a specified pollutant can be reliably measured.

Anglesite

A mineral occurring in crystalline form or as a compact mass.

Antimonial Lead

An alloy composed of lead and up to 25 percent antimony.

Backwashing

The operation of cleaning a filter or column by reversing the flow of liquid through it and washing out matter previously trapped.

Baghouses

The area for housing bag type air filters, an air pollution control equipment device.

Ball Mill

Pulverizing equipment for the grinding of raw material. Grinding is done by steel balls, pebbles, or rods.

Barton Process

A process for making lead oxide to be used in lead acid batteries. Molten lead is fed, agitated, and stirred in a pot with the resulting fine droplets oxidized. Material is collected in a settling chamber where crystalline varieties of lead oxide are formed.

Batch Treatment

A waste treatment method where wastewater is collected over a period of time and then treated prior to discharge. Treatment is not continuous, but collection may be continuous.

Bench Scale Pilot Studies

Experiments providing data concerning the treatability of a wastewater stream or the efficiency of a treatment process conducted using laboratory-size equipment.

Best Available Demonstrated Technology (BDT)

Treatment technology upon which new source performance standards are to be based as defined by Section 306 to the Act.

Best Available Technology Economically Achievable (BAT)

The selected technology applicable to control toxic and nonconventional pollutants on which effluent limitations are established. These limitations are to be achieved by July 1, 1984 by industrial discharges to surface waters as defined by Section 301(b)(2)(C) of the Act.

Best Conventional Pollutant Control Technology (BCT)

The selected technology applicable to control conventional pollutants used to develop effluent limitations to be achieved by July 1, 1984 for industrial discharges to surface waters as defined in Section 301(b)(2)(E) of the Act.

Best Management Practices (BMP)

Regulations intended to control the release of toxic and hazardous pollutants from plant runoff, spillage, leaks, solid waste disposal, and drainage from raw material storage.

Best Practicable Control Technology Currently Available (BPT)

The selected technology applicable to develop effluent limitations to have been achieved by July 1, 1977 (originally) for industrial discharges to surface waters as defined by Section 301(b)(1)(A) of the Act.

Betterton Process

A process used to remove bismuth from lead by adding calcium and magnesium. These compounds precipitate the bismuth which floats to the top of the molten bath where it can be skimmed from the molten metal.

Billet

A long, round slender cast product used as raw material in subsequent forming operations.

Biochemical Oxygen Demand (BOD)

The quantity of oxygen used in the biochemical oxidation of organic matter under specified conditions for a specified time.

Blast Furnace

A furnace for smelting ore concentrates. Heated air is blown in at the bottom to the furnace, producing changes in the combustion rate.

Blister Copper

Copper with 96 to 99 percent purity and appearing blistered; made by forcing air through molten copper matte.

Blowdown

The minimum discharge to circulating water from a unit operation such as a scrubber for the purpose of discharging dissolved solids or other contaminants contained in the water, the further buildup of which would cause concentration in amounts exceeding limits established by best engineering practice.

Building Block

The smallest sub-unit or segment of a subcategory for which a specific effluent limitation is established. Building blocks are directly usable in defining the processes used in a plant and in developing the discharge allowances for that plant.

Calcining

Heating to a high temperature without fusing so as to remove material or make other changes.

Carbon Reduction

The process of using the carbon of coke as a reducing agent in the blast furnace.

Cementation

A process in which metal is added to a solution to initiate the precipitation of another metal. For example, iron may be added to a copper sulfate solution to precipitate Cu:

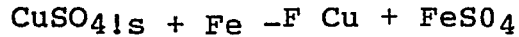
Cerussite

A mineral occurring in crystalline form and made of lead carbonate.

Charge

Material that has been melted by being placed inside a furnace.

Charging Scrap

Scrap material put into a furnace for melting.

Chelation

The formation to coordinate covalent bonds between a central metal ion and a liquid that contains two or more sites for combination with the metal ion.

Chemical Oxygen Demand (COD)

A measure of the oxygen-consuming capacity to the organic and inorganic matter present in the water or wastewater.

Cold-Crucible Arc Melting

Melting and purification of metal in a cold refractory vessel or pot.

Colloid

Suspended solids whose diameter may vary between less than one micron and fifteen microns.

Composite Samples

A series of samples collected over a period of time but combined into a single sample for analysis. The individual samples can be taken after a specified amount of time has passed (time composited), or after a specified volume of water has passed the sampling point (flow composited). The sample can be automatically

collected and composited by a sampler or can be manually collected and combined.

Consent Decree (Settlement Agreement)

Agreement between EPA and various environmental groups, as instituted by the United States District Court for the District of Columbia, directing EPA to study and promulgate regulations for the toxic pollutants (NRDC, Inc. v. Train, 8 ERC 2120 (D.D.C. 1976), modified March 9, 1979, 12 ERC 1833, 1841).

Contact Water

Any water or oil that comes into direct contact with the metal, whether it is raw material, intermediate product, waste product, or finished product.

Continuous Casting

A casting process that produces sheet, rod, or other long shapes by solidifying the metal while it is being poured through an open-ended mold using little or no contact cooling water. Thus, no restrictions are placed on the length of the product and it is not necessary to stop the process to remove the cast product.

Continuous Treatment

Treatment of waste streams operating without interruption as opposed to batch treatment. Sometimes referred to as flow-through treatment.

Contractor Removal

Disposal of oils, spent solutions, or sludge by a commercial firm.

Conventional Pollutants

Constituents of wastewater as determined by Section 304(a)(4) of the Act, including but not limited to pollutants classified as biological-oxygen-demanding, oil and grease, suspended solids, fecal coliforms, and pH.

Converting

The process of blowing air through molten metal to oxidize impurities.

Cooling Tower

A hollow, vertical structure with internal baffles designed to break up falling water so that it is cooled by upward-flowing air and the evaporation of water.

Copper Matte

An impure sulfide mixture formed by smelting the sulfide ores in copper.

Cupelled

Refined by means of a small shallow porous bone cup that is used in assaying precious metals.

Cupola Furnace

A vertical cylindrical furnace for melting materials on a small scale. This furnace is similar to a reverberatory furnace but only on a smaller scale.

Cyclones

A funnel-shaped device for removing particulates from air or other fluids by centrifugal means.

Data Collection Portfolio (dcp)

The questionnaire used in the survey of the nonferrous metals manufacturing industry.

Degassing

The removal of dissolved hydrogen from the molten metal prior to casting. This process also helps to remove oxides and impurities from the melt.

Direct Chill Casting

A method of casting where the molten metal is poured into a water-cooled mold. The base of this mold is the top of a hydraulic cylinder that lowers the aluminum first through the mold and then through a water spray and bath to cause solidification. The vertical distance of the drop limits the length of the ingot. This process is also known as semi-continuous casting.

Direct Discharger

Any point source that discharges to a surface water.

Dore

Gold and silver bullion remaining in a cupelling furnace after oxidized lead is removed.

Dross

Oxidized impurities occurring on the surface of molten metal.

Drying Beds

Areas for dewatering of sludge by evaporation and seepage.

Effluent

Discharge from a point source.

Effluent Limitation

Any standard (including schedules of compliance) established by a state or EPA on quantities, rates, and concentrations of chemical, physical, biological, and other constituents that are discharged from point sources into navigable waters, the waters of the contiguous zone, or the ocean.

Electrolysis

A method of producing chemical reactions by sending electric current through electrolytes or molten salt.

Electrolytic Refining

A purification process in which metals undergo electrolysis.

Electrolytic Slime

Insoluble impurities removed from the bottom of an electrolytic cell during electrolytic refining.

Electron Beam Melting

A melting process in which an electron beam is used as a heating source.

Electrostatic Precipitator (ESP)

A gas cleaning device that induces an electrical charge on a solid particle which is then attracted to an oppositely charged collector plate. The collector plates are intermittently vibrated to discharge the collected dust to a hopper.

End-of-Pipe Treatment

The reduction of pollutants by wastewater treatment prior to discharge or reuse.

Film Stripping

Separation of silver-bearing material from scrap photographic film.

Fluid Bed Roaster

A type of roaster in which the material is suspended in air during roasting.

Fluxes

Substances added to molten metal to help remove impurities and prevent excessive oxidation, or promote the fusing of the metals.

Galena

A bluish gray mineral occurring in the form of crystals, masses, or grains; it constitutes the principal ore of lead.

Gangue

Valueless rock and mineral mined with ore. When separated from ore, the material is known as "slag."

Gas Chromatography/Mass Spectroscopy (GC/MS)

Chemical analytical instrumentation used for quantitative organic analysis.

Grab Sample

A single sample of wastewater taken without regard to time or flow.

Hardeners

Master alloys that are added to a melt to control hardness.

Harris Process

A process in which sodium hydroxide and sodium nitrate are added to molten lead to soften or refine it. These two compounds react with impurities in the molten metal forming a slag that floats to the top of the molten metal.

Humidification Chamber

A chamber in which the water vapor content of a gas is increased.

Hydrogenation

The addition of hydrogen to a molecule.

Hydrometallurgical

The use of wet processes to treat metals.

Indirect Discharger

Any point source that discharges to a publicly owned treatment works.

Inductively-Coupled Argon Plasma Spectrophotometer (ICAP)

A laboratory device used for the analysis of metals.

Ingot

A large, block-shaped casting produced by various methods. Ingots are intermediate products from which other products are made.

In-Process Control Technology

Any procedure or equipment used to conserve chemicals and water throughout the production operations, resulting in a reduction of the wastewater volume.

Litharge

A yellowish lead oxide compound with a crystalline form; also known as lead monoxide.

Matte

A metal sulfide mixture produced by smelting sulfide ores.

Mischmetal

A rare earth metal alloy comprised of 94 to 99 percent of the natural mixture of rare earth metals. The balance of the alloy includes traces of other elements and 1 to 2 percent iron.

Mitsubishi Process

A process used in primary copper refining which incorporates three furnaces to combine roasting, smelting, and converting into one continuous process. The Mitsubishi process results in reduced smelting rates and heating costs.

New Source Performance Standards (NSPS)

Effluent limitations for new industrial point sources as defined by Section 306 of the Act.

Nonconventional Pollutant

Parameters selected for use in performance standards that have not been previously designated as either conventional or toxic pollutants.

Non-Water Quality Environmental Impact

The ecological impact as a result to solid, air, or thermal pollution due to the application to various wastewater technologies to achieve the effluent guidelines limitations. Also associated with the non-water quality aspect is the energy impact of wastewater treatment.

NPDES Permits

Permits issued by EPA or an approved state program under the National Pollutant Discharge Elimination System as required by the Clean Water Act.

Off-Gases

Gases, vapors, and fumes produced as a result of a metal forming operation.

Oil and Grease (O&G)

Any material that is extracted by freon from an acidified sample and that is not volatilized during the analysis, such as hydrocarbons, fatty acids, soaps, fats, waxes, and oils.

Outokumpu Furnace

A furnace used for flash smelting, in which hot sulfide concentrate is fed into a reaction shaft along with preheated air and fluxes. The concentrate roasts and smelts itself in a single autogeneous process.

Parke's Process

A process in which zinc is added to molten lead to form insoluble zinc-gold and zinc-silver compounds. The compounds are skimmed and the zinc is removed through vacuum de-zincing.

Pelletized

An agglomeration process in which an unbaked pellet is heat hardened. The pellets increase the reduction rate in a blast furnace by improving permeability and gas-solid contact.

pH

The pH is the negative logarithm of the hydrogen ion activity of a solution.

Platinum Group Metals

A name given to a group of metals comprised of platinum, palladium, rhodium, iridium, osmium, and ruthenium.

Pollutant Parameters

Those constituents of wastewater determined to be detrimental and, therefore, requiring control.

Precious Metals

A generic term referring to the elements gold, silver, platinum, palladium, rhodium, iridium, osmium, and ruthenium as a group.

Precipitation Supernatant

A liquid or fluid forming a layer above precipitated solids.

Priority Pollutants

Those pollutants included in Table 2 of Committee Print number 95-30 of the "Committee on Public Works and Transportation of the House of Representatives," subject to the Act.

Process Water

Water used in a production process that contacts the product, raw materials, or reagents.

Production Normalizing Parameter (PNP)

The unit to production specified in the regulations used to determine the mass of pollution a production facility may discharge.

PSES

Pretreatment standards (effluent regulations) for existing sources applicable to indirect dischargers.

PSNS

Pretreatment standards (effluent regulations) for new sources applicable to new indirect dischargers.

Publicly Owned Treatment Works (POTW)

A waste treatment facility that is owned by a state or municipality.

Pug Mill

A machine for mixing and tempering a plastic material by the action to blades revolving in a drum or trough.

Pyrometallurgical

The use to high-temperature processes to treat metals.

Raffinate

Undissolved liquid mixture not removed during solvent refining.

Rare Earth Metals

A name given to a group of elements including scandium, yttrium, and lanthanum to lutetium, inclusive.

Recycle

Returning treated or untreated wastewater to the production process from which it originated for use as process water.

Reduction

A reaction in which there is a decrease in valence resulting from a gain in electrons.

Reuse

The use of treated or untreated process wastewater in a different production process.

Reverberatory Furnaces

Rectangular furnaces in which the fuel is burned above the metal and the heat reflects off the walls and into the metal.

Roasting

Heating ore to remove impurities prior to smelting. Impurities within the ore are oxidized and leave the furnace in gaseous form.

Rod

An intermediate metal product having a solid, round cross section 9.5 mm (3/8 inches) or more in diameter.

Rotary Furnace

A circular furnace which rotates the workpiece around the axis of the furnace during heat treatment.

Scrubber Liquor

The untreated wastewater stream produced by wet scrubbers cleaning gases produced by metal manufacturing operations.

Shot Casting

A method of casting in which molten metal is poured into a vibrating feeder, where droplets of molten metal are formed through perforated openings. The droplets are cooled in a quench tank.

Sintering

The process of forming a bonded mass by heating metal powders without melting.

Skimmings

Slag removed from the surface of smelted metal.

Slag

The product of fluxes and impurities resulting from the smelting of metal.

Smelting

The process of heating ore mixtures to separate liquid metal and impurities.

Soft Lead

Lead produced by the removal of antimony through oxidation. The lead is characterized by low hardness and strength.

Spent Hypo Solution

A solution consisting of photographic film fixing bath and wash water which contains unreduced silver from film processing.

Stationary Casting

A process in which the molten metal is poured into molds and allowed to air-cool. It is often used to recycle in-house scrap.

Subcategorization

The process of segmentation of an industry into groups of plants for which uniform effluent limitations can be established.

Supernatant

A liquid or fluid forming a layer above settled solids.

Surface Water

Any visible stream or body of water, natural or man-made. This does not include bodies of water whose sole purpose is wastewater retention or the removal of pollutants, such as holding ponds or lagoons.

Surfactants

Surface active chemicals that tend to lower the surface tension between liquids.

Sweating

Bringing small globules of low-melting constituents to an alloy surface during heat treatment.

Total Dissolved Solids (TDS)

Organic and inorganic molecules and ions that are in true solution in the water or wastewater.

Total Organic Carbon (TOC)

A measure of the organic contaminants in a wastewater. The TOC analysis does not measure as much of the organics as the COD or BOD tests, but is much quicker than these tests.

Total Recycle

The complete reuse of a stream, with make-up water added for evaporation losses. There is no blowdown stream from a totally recycled flow and the process water is not periodically or continuously discharged.

Total Suspended Solids (TSS)

Solids in suspension in water, wastewater, or treated effluent. Also known as suspended solids.

Traveling Grate Furnace

A furnace with a moving grate that conveys material through the heating zone. The feed is ignited on the surface as the grate moves past the burners; air is blown in the charge to burn the fuel by downdraft combustion as it moves continuously toward discharge.

Tubing Blank

A sample taken by passing one gallon of distilled water through a composite sampling device before initiation of actual wastewater sampling.

Tuyere

Openings in the shell and refractory lining of a furnace through which air is forced.

Vacuum Dezincing

A process for removing zinc from a metal by melting or heating the solid metal in a vacuum.

Venturi Scrubbers

A gas cleaning device utilizing liquid to remove dust and mist from process gas streams.

Volatile Substances

Materials that are readily vaporizable at relatively low temperatures.

Wastewater Discharge Factor

The ratio between water discharged from a production process and the mass of product of that production process. Recycle water is not included.

Water Use Factor

The total amount of contact water or oil entering a process divided by the amount of product produced by this process. The amount of water involved includes the recycle and make-up water.

Wet Scrubbers

Air pollution control devices used for removing pollutants as the gas passes through the spray.

Zero Discharger

Any industrial or municipal facility that does not discharge wastewater.

The following sources were used for defining terms in the glossary:

Gill, G. B., Nonferrous Extractive Metallurgy. John Wiley & Sons, New York, NY, 1980.

Lapedes, Daniel N., Dictionary of Scientific and Technical Terms, 2nd edition. New York, NY, McGraw-Hill Book Co., 1978.

McGannon, Harold E., The Making, Shaping, and Treating of Steel, 9th edition. Pittsburgh, PA, U.S. Steel Corp., 1971.

THIS PAGE INTENTIONALLY LEFT BLANK