

*EPA-440/1-74-018-a*

*Development Document for Effluent Limitations Guidelines  
and New Source Performance Standards for the*

# **SOAP AND DETERGENT**

*Manufacturing  
Point Source Category*

APRIL 1974



U.S. ENVIRONMENTAL PROTECTION AGENCY  
Washington, D.C. 20460

DEVELOPMENT DOCUMENT

for

**EFFLUENT LIMITATIONS GUIDELINES**

and

**NEW SOURCE PERFORMANCE STANDARDS**

**SOAP AND DETERGENT MANUFACTURING  
POINT SOURCE CATEGORY**

**Russell E. Train  
Administrator**

**James L. Agee  
Acting Assistant Administrator for Water and Hazardous Materials**



**Allen Cywin  
Director, Effluent Guidelines Division**

**Richard T. Gregg  
Project Officer**

**April, 1974**

**Effluent Guidelines Division  
Office of Water and Hazardous Materials  
U.S. Environmental Protection Agency  
Washington, D.C. 20460**



## ABSTRACT

This document presents the findings of an extensive study of the soap and detergent manufacturing industry by Colin A. Houston and Associates for the Environmental Protection Agency for the purpose of developing effluent limitations guidelines, Federal standards of performance, and pretreatment standards for the industry to implement Sections 304, 306 and 307 of the Federal Water Pollution Control Act Amendments of 1972.

Effluent limitations guidelines recommended herein set forth the degree of effluent reduction attainable through the application of the best practicable control technology currently available and the degree of effluent reduction attainable through application of the best available technology economically achievable, which must be achieved by existing point sources by July 1, 1977, and July 1, 1983, respectively. The Standards of Performance for new sources recommended herein set the degree of effluent reduction which is achievable through application of the best available demonstrated control technology, processes, operating methods, or other alternatives.

The development of data and recommendations in the document relate to the nineteen subcategories into which the industry was divided on the basis of raw waste loads and appropriate control and treatment technology. Separate effluent limitations are proposed for each subcategory on the basis of raw waste load control and end-of-pipe treatment achievable by suggested model systems.

Supportive data and rationales for development of the proposed effluent limitations guidelines and standards of performance are contained in this report. Potential approaches for achieving the limitations levels and their associated costs are discussed.



## CONTENTS

<u>Section</u>		<u>Page</u>
I	CONCLUSIONS	1
	General	1
	Categorization	2
	History and Source of Data	3
	Integrated Plants	3
	Potential Developments	4
II	RECOMMENDATIONS	5
III	INTRODUCTION	13
	Purpose and Authority	13
	Limitations Guidelines and Standards of Performance	14
	General Description of the Industry	15
	Historical	15
	Companies and Markets	16
	Industrial Cleaning Compounds	18
	Sales and Production	19
	Physical Plant	19
	Trade Practices	19
	Industry Problems	20
	Future Trends	20
	Soap Process Descriptions	20
	Soap Manufacture by Batch Kettle	20
	Fatty Acid Manufacture by Fat Splitting	24
	Soap From Fatty Acid Neutralization	26
	Glycerine Recovery	29
	Soap Flakes and Powders	31
	Bar Soap	33
	Liquid Soap	35
	Detergent Process Descriptions	37
	Oleum Sulfonation/Sulfation	38
	Air-SO <sub>3</sub> Sulfonation/Sulfonation	38
	SO <sub>3</sub> Solvent and Vacuum Sulfonation	41
	Sulfamic Acid Sulfation	41
	Chlorosulfonic Acid Sulfation	41
	Neutralization of Sulfuric Acid Esters and Sulfonic Acids	45
	Spray Dried Detergents	45
	Liquid Detergents	47
	Dry Detergent Blending	49
	Drum Dried Detergents	49
	Detergent Bars and Cakes	53
	Formulations	53

<u>Section</u>		<u>Page</u>
IV	INDUSTRY CATEGORIZATION	59
	Introduction	59
	Categorization	60
V	WASTE CHARACTERIZATION	63
	Introduction	63
	Soap Manufacture by Batch Kettle	63
	Fatty Acids by Fat Splitting	65
	Soap by Fatty Acid Neutralization	66
	Glycerine Recovery	66
	Soap Flakes and Powders	68
	Bar Soaps	68
	Liquid Soaps	69
	Oleum Sulfonation and Sulfation	69
	Air-SO <sub>3</sub> Sulfonation and Sulfation	70
	SO <sub>3</sub> Solvent and Vacuum Sulfonation	71
	Sulfamic Acid Sulfation	72
	Chlorosulfonic Acid Sulfation	72
	Neutralization of Sulfuric Acid Esters and Sulfonic Acids	73
	Spray Dried Detergents	74
	Liquid Detergent Manufacture	75
	Detergent Manufacturing by Dry Blending	77
	Drum Dried Detergents	77
	Detergent Bars and Cakes	77
VI	POLLUTANT PARAMETERS	79
	Introduction	79
	Control Parameter Recommendations	79
	Biochemical Oxygen Demand	79
	<b>Chemical Oxygen Demand</b>	81
	Suspended Solids	81
	Surfactants (MBAS)	82
	Oil and Grease	82
	pH	83
	Parameters Omitted	84
	Nitrogen	84
	Phosphorus and Boron	84
	Scope of Parameter Measurements - By Process	85
	Soap Manufacture by Batch Kettle	85
	Fatty Acids by Fat Splitting	86
	Soap by Fatty Acid Neutralization	86
	Glycerine Recovery	86
	Soap Flakes and Powders	87
	Bar Soaps	87
	Liquid Soap	87

<u>Section</u>		<u>Page</u>
	Oleum Sulfonation and Sulfation	88
	Air-SO <sub>3</sub> Sulfation and Sulfonation	88
	SO <sub>3</sub> Solvent and Vacuum Sulfonation	88
	Sulfamic Acid Sulfation	88
	Neutralization of Sulfuric Acid Esters and Sulfonic Acids	89
	Spray Dried Detergents	89
	Liquid Detergents	90
	Dry Detergent Blending	90
	Drum Dried Detergents	90
	Detergent Bars and Cakes	90
	Industrial Cleaners	90
VII	CONTROL AND TREATMENT TECHNOLOGY	93
	Introduction	93
	Nature of Pollutants	94
	Discussion of Treatment Techniques	95
	Oil and Grease Removal	95
	Coagulation and Sedimentation	98
	Bioconversion Systems	98
	Carbon Absorption Systems	98
	Filtration for Removal of Suspended Solids	98
	Dissolved Solids Removal	99
	Other Treatment Technique Considerations	99
	Special Operational Aspects of Control Technology	100
	Solid Waste Generation Associated with Treatment Technology	103
VIII	COST, ENERGY AND NONWATER QUALITY ASPECTS	105
	In-Plant Control	105
	Impurities Removal	106
	By-product/Degradation Product Control	107
	Dilute Product from Cleanouts, Leaks and Spills	108
	End-of-Pipe Treatment	108
	Energy Requirements	113
	Nonwater Quality Aspects	113
	Implementation of Treatment Plans	114
IX	BEST PRACTICABLE CONTROL TECHNOLOGY CURRENTLY AVAILABLE	117
	Introduction	117
	Soap Manufacture by Batch Kettle	118
	Fatty Acid Manufacture by Fat Splitting	123
	Fatty Acid Hydrogenation	126
	Soap from Fatty Acid Neutralization	126
	Glycerine Recovery	127
	Soap Flake and Powders	130



<u>Section</u>		<u>Page</u>
	Bar Soaps	131
	Liquid	133
	Oleum Sulfonation and Sulfation	134
	Air-SO <sub>3</sub> Sulfation and Sulfonation	135
	SO <sub>3</sub> Solvent and Vacuum Sulfonation	137
	Sulfamic Acid Sulfation	138
	Chlorosulfonic Acid Sulfation	139
	Neutralization of Sulfuric Acid Esters and Sulfonic Acids	140
	Spray Dried Detergents	142
	Liquid Detergent Manufacture	146
	Dry Detergent Blending	148
	Drum Dried Detergents	149
	Detergent Bars and Cakes	150
X	BEST CONTROL TECHNOLOGY ECONOMICALLY ACHIEVABLE	153
	Introduction	153
	Modified Soap Manufacture by Batch Kettle	155
	Fatty Acid Manufacture by Fat Splitting	155
	Glycerine Recovery and Concentration	159
	Bar Soaps	162
	Air-SO <sub>3</sub> Sulfation and Sulfonation	166
	SO <sub>3</sub> Solvent and Vacuum Sulfonation	166
	Sulfamic Acid Sulfation	166
	Chlorosulfonic Acid Sulfation	166
	Spray Dried Detergents	166
	Liquid Detergents	167
	Detergent Bars and Cakes	167
XI	NEW SOURCE PERFORMANCE STANDARDS AND PRETREATMENT STANDARDS	169
	Introduction	169
	Soap Manufacture by Batch Kettle	171
	Soap from Fatty Acid Neutralization	172
	Bar Soap - Drying	173
	Solvent Process for Soap Manufacture	173
	Oleum Sulfation and Sulfonation	174
	Air-SO <sub>3</sub> Sulfation and Sulfonation	174
	Pretreatment Requirements	183
	Fats and Oils	183
	Fats and Oils - Detergent Plants	184
	Zinc	184
	Industrial Cleaners	184
XII	ACKNOWLEDGEMENTS	187
XIII	REFERENCES	189
XIV	GLOSSARY	195

## TABLES

<u>Number</u>		<u>Page</u>
1	Summary Value of Shipments at Manufacturers Level Soaps and Detergents SIC 2841	17
2	Treatment Methods Used in Elimination of Pollutants	96
3	Relative Efficiency of Several Methods Used in Removing Pollutants	97
4	Range of Water Use by Process	105
5	Cost and Energy Requirements Associated with Various Treatment Methods	109
6	Cost of Sludge Conditioning and Disposal Operations	116
7-1	Best Available Technology Economically Achievable Guidelines Reflecting No Change From Best Practicable Control Technology Currently Available	153
7-2	Best Available Technology Economically Achievable Guidelines Reflecting Changes From Best Practicable Control Technology Currently Available	154
8	New Source Performance Standards Guidelines	170



## FIGURES

<u>Number</u>	<u>Title</u>	<u>Page</u>
1	Soap Manufacture by Batch Kettle	22
2	Soap Making	25
3	Fatty Acid Manufacture by Fat Splitting	27
4	Soap From Fatty Acid Neutralization	28
5	Glycerine Recovery	30
6	Soap Flakes and Powders	32
7	Bar Soaps	34
8	Liquid Soap Processing	36
9	Oleum Sulfation and Sulfonation (Batch and Continuous)	39
10	Air-SO <sub>3</sub> Sulfation and Sulfonation (Batch and Continuous)	40
11	SO <sub>3</sub> Solvent and Vacuum Sulfonation	42
12	Sulfamic Acid Sulfation	43
13	Chlorosulfonic Acid Sulfation	44
14	Neutralization of Sulfuric Acid Esters and Sulfonic Acids	46

<u>Number</u>	<u>Title</u>	<u>Page</u>
15	Spray Dried Detergents	48
16	Liquid Detergent Manufacture	50
17	Detergent Manufacture by Dry Blending	51
18	Drum Dried Detergent	52
19	Detergent Bars and Cakes	54
20	Composite Flow Sheet Waste Treatment Soap and Detergent Industry	101
21	Sludge Solids Handling Soap and Detergent Industry	102
22	Waste Water Sources in Soap Manufacture	120
23	Fat Splitting	121
24	Fats Recovery System	125
25	Glycerine Concentration	128
26	Soap Manufacture by Batch Kettle: Modified	156
27	Modified: Fatty Acid Manufacture by Fat Splitting	157
28	Fatty Acids Manufacture: Hydrogenation Step, If Carried Out	158

<u>Number</u>	<u>Title</u>	<u>Page</u>
29	Glycerine Recovery	160
30	Concentration of 80% Glycerine to 99.5%	161
31	Continuous Detergent Slurry Processing Plant High-Active Alkylate Sulfonation with Oleum	176
32	Continuous Detergent Slurry Processing Plant Fatty Alcohol Sulfation with Oleum	177
33	Soap Manufacture by Continuous Saponification	178
34	Soap by Continuous Fatty Acid Neutralization and Neat Soap Drying: For Bar Soaps	179
35	Combined Processes SO <sub>3</sub> Sulfonation/Sulfation- Continuous and Neutralization of Sulfonic or Alkyl Sulfuric Acid Processes-Continuous	180
36	Fatty Alcohol Sulfation: With SO <sub>3</sub>	181
37	Alpha-Olefin Sulfonation with SO <sub>3</sub>	182



## SECTION I

### CONCLUSIONS

#### General

The manufacturing of soaps and synthetic detergents represents a minor source of water pollution. The industry uses approximately 15,160 million liters a year (or 4 billion gallons a year) as process water. The pollutants emanating from its plants are nontoxic and readily responsive to treatment. Some exceptions to this statement exist in the industrial surfactant area and are discussed in this report. More than 95 percent of plant effluents go to municipal treatment plants with less than 5 percent classed as point sources.

Virtually all of the 5.8 billion kilograms (12.8 billion pounds) of product estimated from these plants in 1973 is destined for the nation's treatment plants and waterways; the intricacies of the manufacturing processes of this industry warrant better understanding.

Soaps and detergents are performance products. (By dictionary definition a detergent is a cleaning agent and includes ordinary bar soap, which is classically based on natural fat. In popular usage, however, the term detergent excludes soap, being restricted to the family of cleaning compounds derived largely from petrochemicals. This report follows popular usage.) Literally thousands of chemical compositions can be formulated which clean a surface. Detergents can be formulated with entirely different organic and inorganic chemicals to exhibit the same cleaning power or have the same biodegradability. They also can be formulated to:

1. Maximize cleaning power
2. Maximize biodegradability
3. Minimize eutrophication potential in a specific receiving water
4. Maximize cleaning power/unit cost
5. Minimize air or water pollutants and solid wastes arising from the manufacturing processes.

Guidelines can be directed toward minimized water pollution from manufacturing, but not to the extent of excluding consideration of other factors. It is possible today to design formulas to give almost zero discharge of pollutants from the manufacturing process. However, the imposition of such low pollutant discharge limits on water from the plants of the industry might result in forcing radical reformulations with adverse effects in other areas of environmental concern. For example, one formulation



which would enable a zero discharge from a manufacturing plant was voluntarily discarded by the industry 10 years ago because of its poor biodegradability.

### Categorization

For the purpose of establishing effluent limitation guidelines and standards of performance, the soap and detergent industry can be divided into 19 subcategories based on processes and products.

#### SOAP MANUFACTURE

##### PROCESS DESCRIPTION

Soap Manufacture - Batch Kettle and Continuous (101)  
Fatty Acid Manufacture by Fat Splitting (102)  
Soap From Fatty Acid Neutralization (103)  
Glycerine Recovery (104)  
Glycerine Concentration (104A)  
Glycerine Distillation (104B)  
Soap Flakes & Powders (105)  
Bar Soaps (106)  
Liquid Soap (107)

#### DETERGENT MANUFACTURE

##### PROCESS DESCRIPTION

Oleum Sulfonation & Sulfation (Batch & Continuous) (201)  
Air SO<sub>3</sub> Sulfation and Sulfonation (Batch & Continuous) (202)  
SO<sub>3</sub> Solvent and Vacuum Sulfonation (203)  
Sulfamic Acid Sulfation (204)  
Chlorosulfonic Acid Sulfation (205)  
Neutralization of Sulfuric Acid Esters & Sulfonic Acids (206)  
Spray Dried Detergents (207)  
Liquid Detergent Manufacture (208)  
Detergent Manufacturing By Dry Blending (209)  
Drum Dried Detergents (210)  
Detergent Bars & Cakes (211)

The code numbers shown after the processes are used to identify them throughout this report.

These subcategories cover the major unit operations of the soap and synthetic detergent industry as it is established in the Federal Standard Industrial Classification Manual, Industry Code Number 2841. Some special processes in the production of surfactants have been omitted, namely:

Amine Oxides	Quaternaries	Isethionates
Amides	Alkyl Glyceryl Ether	Hydrotropes
Taurides	Sulfonates	

The categories covered in this report allow the permit granting authority to identify the unit operations in a soap and detergent plant and the important measurable effluents associated with each. Where several units are present in the same plant, the permit granting authority can establish a maximum permissible effluent standard for a given plant by adding the effluent allowable from each unit. Where a large number of units are grouped together in a single plant it is possible to reduce the total permissible effluent that would be arrived at simply by adding the individual units in that site. Techniques for such reduction are covered in the body of this report.

#### HISTORY AND SOURCE OF DATA

When the study was initiated on January 16, 1973, there were no detailed effluent studies available on this industry. A literature search including previous EPA and state work yielded little useful data. The Corps of Engineers permit applications yielded little correlatable data since information as to the products produced and any relationship of product or processes to effluent flows was lacking. Another problem then arose when it was found that the soap and detergent companies possessed little or no detailed data regarding their effluent flows. Most effluent data from the companies turned out to be on combined sewers (combining the effluent of three to ten process units) and hence were of limited value. Therefore, the sample program originally conceived by the EPA and Contractor as a program to verify literature and company-provided information had to be enlarged and turned into a major research project. Though a relatively sound data base was obtained, ideally such data should be obtained by composite sampling over a period lasting from thirty days to a year. Because of the great pressure to complete this work to enable the EPA to publish guidelines October 18, 1973, as called for in the Act, Public Law 92-500, it was impossible to run any composite program longer than one week. A number of the sample programs initiated are being continued voluntarily by the companies, and more sophisticated information has begun to come in.

For publication of this report, it was necessary to foreclose use of further data June 15, 1973. The data flow is expected to continue and, after collation, is being turned over to the EPA as received. A major conclusion stemming from this work is the recognition of the necessity of arranging for a long term EPA depository for industry effluent data so that water handling problems can be fairly and inventively dealt with.

#### Integrated Plants

An important conclusion reached in this study was that integrated plants having a group of several unit processes at the same plant site have a substantial advantage in their ability to minimize pollution by cascading water and working off the by-products from one process into another unit process step. Although we have indicated many places where we believe the permit writer should, for this reason, apply more lenient standards to the small one or two unit process plant, this is really an area needing case by case evaluation.

#### Potential Developments

This report is written around soaps and synthetic detergents as formulated in 1973. From a national treatment standpoint, and to lessen the possible eutrophication impact of soap and detergent formulas, it may be necessary to change the 1973 formulas considerably. Such changes will result in different effluents from the production units. In the soap and glycerine field, changes in formulation are not likely to be very pronounced, but they are in detergent bars, powders and liquids. Substantial changes in effluents from unit processes and hence detergent plants may be necessary to minimize ecological impact of the end product in specific receiving watersheds. Particularly in this industry, the guidelines need to be reviewed periodically to adjust to improvements in formulas.

## SECTION II

### RECOMMENDATIONS

As a result of the findings of this report the following recommendations are made:

1. That the effluent limitations and standards of performance be based on the level of waste reduction attainable as an average for a thirty day period with the following values established for the designated segments of the industry. (All values are given in terms of kilograms (kg) of pollutant per kkg of the anhydrous product produced in the numbered process given. As all values express weight to weight ratios the units are interchangeable and lb can be substituted for kg. For example, 0.6 kg BOD<sub>5</sub> per kkg of product is an identical ratio to 0.6 lb BOD<sub>5</sub> per 1000 lb of product.)

#### Best Practicable Control Technology Currently Available

Subcategory	BOD <sub>5</sub>	COD	Suspended Solids	Surfactants	Oil & Grease
Soap Manufacture Batch Kettle	0.60	1.50	0.40	NA	0.10
Fatty Acid Manufacture By Fat Splitting	1.20	3.30	2.20	NA	0.30
Hydrogenation	0.15	0.25	0.10	NA	0.10
Soap From Fatty Acid Neutrali- zation	0.01	0.05	0.02	NA	0.01
Glycerine Con- centration	1.50	4.50	0.20	NA	0.10
Glycerine Dis- tillation	0.50	1.50	0.20	NA	0.10
Soap Flakes and Powders	0.01	0.05	0.01	NA	0.01
Bar Soaps	0.34	0.85	0.58	NA	0.04
Liquid Soaps	0.01	0.05	0.01	NA	0.01
Oleum Sulfona- tion & Sulfa- tion (Batch & Continuous)	0.02	.09	0.03	0.03	0.07

Air-SO <sub>3</sub> Sulfation & Sulfonation (Batch & Continuous)	0.30	1.35	0.03	0.30	0.05
SO <sub>3</sub> Solvent & Vacuum Sulfonation Sulfamic	0.30	1.35	0.03	0.30	0.05
Acid Sulfation	0.30	1.35	0.03	0.30	0.05
Chlorosulfonic Acid Sulfation	0.30	1.35	0.03	0.30	0.05
Neutralization of Sulfuric Acid Ester & Sulfonic Acids	0.01	0.05	0.03	0.02	0.01
Spray Dried Detergents (normal)	0.01	0.05	0.01	0.02	0.005
Spray Dried Detergents (air restrictions)	0.08	0.35	0.10	0.15	0.03
Spray Dried Detergents (fast turnaround)*	0.02	0.09	0.02	0.03	0.005
Liquid Detergent Manufacture	0.20	0.60	0.005	0.13	0.005
Liquid Detergent Manufacture (fast turnaround)**	0.05	0.15	0.002	0.04	0.002
Detergent Manufacturing by Dry Blending	0.01	0.07	0.01	0.01	0.005
Drum Dried Detergents	0.01	0.05	0.01	0.01	0.01
Detergent Bars & Cakes	0.70	3.30	0.20	0.50	0.02

- \* Allowance for each turnaround in excess of six in a 30-day period.
- \*\* Allowance for each turnaround in excess of eight in a 30-day period.

Best Available Technology Economically Achievable

Subcategory	BOD <sub>5</sub>	COD	Suspended Solids	Surfactants	Oil & Grease
Soap Manufacture Batch Kettle	0.40	1.05	0.40	NA	0.05
Fatty Acid Manufacture by Fat Splitting	0.25	0.90	0.20	NA	0.15
Hydrogenation	0.15	0.25	0.10	NA	0.10
Soap From Fatty Acid Neutralization	0.01	0.05	0.02	NA	0.01
Glycerine Concentration	0.40	1.20	0.10	NA	0.04
Glycerine Distillation	0.30	0.90	0.04	NA	0.02
Soap Flakes and Powders	0.01	0.05	0.01	NA	0.01
Bar Soaps	0.20	0.60	0.34	NA	0.03
Liquid Soap	0.01	0.05	0.01	NA	0.01
Oleum Sulfonation & Sulfation (Batch & Continuous)	0.02	0.09	0.03	0.03	0.07
Air-SO <sub>3</sub> Sulfonation and Sulfonation (Batch & Continuous)	0.19	0.55	0.02	0.18	0.04
SO <sub>3</sub> Solvent and Vacuum Sulfonation	0.10	0.45	0.01	0.10	0.02
Sulfamic Acid Sulfation	0.10	0.45	0.01	0.10	0.02
Chlorosulfonic Acid Sulfation	0.15	0.75	0.02	0.15	0.03

Neutralization of Sulfuric Acid Esters & Sulfonic Acids	0.01	0.05	0.03	0.02	0.01
Spray Dried Detergents (normal)	0.01	0.04	0.02	0.02	0.005
Spray Dried Detergents (air restrictions)	0.06	0.25	0.07	0.10	0.02
Spray Dried Detergents (fast turnaround)	0.02	0.07	0.02	0.02	0.005
Liquid Deter- gent Manufacture	0.05	0.22	0.005	0.05	0.005
Liquid Deter- gent Manufacture (fast turnaround)	0.02	0.07	0.002	0.02	0.002
Detergent Manu- facturing by Dry Blending	0.01	0.07	0.01	0.01	0.005
Drum Dried Detergents	0.01	0.05	0.01	0.01	0.01
Detergent Bars & Cakes	0.30	1.35	0.10	0.20	0.02



Standards of Performance for New Sources

Subcategory	BOD <sub>5</sub>	COD	Suspended Solids	Surfactants	Oil & Grease
Soap Manufacture Batch Kettle	0.40	1.05	0.40	NA	0.05
Fatty Acid Manufacture by Fat Splitting	0.25	0.90	0.20	NA	0.15
Hydrogenation	0.15	0.25	0.10	NA	0.10
Soap From Fatty Acid Neutralization	0.01	0.05	0.02	NA	0.01
Glycerine Concentration	0.40	1.20	0.10	NA	0.04
Glycerine Distillation	0.30	0.90	0.04	NA	0.02
Soap Flakes & Powders	0.01	0.05	0.01	NA	0.01
Bar Soaps	0.20	0.60	0.34	NA	0.03
Liquid Soap	0.01	0.05	0.01	NA	0.01
Oleum Sulfonation & Sulfation (Batch & Continuous)	0.01	0.03	0.02	0.01	0.04
Air-SO <sub>3</sub> Sulfation & Sulfonation (Batch & Continuous)	0.09	0.40	0.02	0.09	0.02
SO <sub>3</sub> Solvent & Vacuum Sulfonation	0.10	0.45	0.01	0.10	0.02
Sulfamic Acid Sulfation	0.10	0.45	0.01	0.10	0.02
Chlorosulfonic Acid Sulfation	0.15	0.75	0.02	0.15	0.03

Neutralization of Sulfuric Acid Esters & Sulfonic Acids	0.01	0.04	0.03	0.02	0.01
Spray Dried Detergents (Normal)	0.01	0.04	0.02	0.02	0.005
Spray Dried Detergents (Air restricted)	0.06	0.25	0.07	0.10	0.02
Spray Dried Detergents (Fast turnaround)	0.02	0.07	0.02	0.02	0.005
Liquid Detergent Manufacture	0.05	0.22	0.005	0.05	0.005
Liquid Detergent Manufacture (fast turnaround)	0.02	0.07	0.0002	0.02	0.002
Detergent Manufacturing by Dry Blending	0.01	0.07	0.01	0.01	0.005
Drum Dried Detergents	0.01	0.05	0.01	0.01	0.01
Detergent Bars & Cakes	0.30	1.35	0.10	0.20	0.02

The pH of final discharge(s) should be within the range of 6.0-9.0 at all times.

2. For purposes of monitoring and enforcement, periods and values other than those for the 30-day average should be adopted. Daily maximums 3 times and 2 times the 30-day averages are recommended as reflecting reliability of control and treatment for best practicable and best available control

3. A continuing effort is recommended to further study the waste water effluent problems of the soap and detergent field, particularly detergents. The technology is in a state of rapid flux and merits close observation.

Basically two areas should be considered:

- (a) Changes in detergent formulations and how they affect wastes associated with manufacture and the environmental

impact resulting from use by the consumer.

- (b) Control and treatment practices as they affect water pollution, air pollution, and solid waste.

## SECTION III

### INTRODUCTION

#### Purpose and Authority

Section 301(b) of the Act requires the achievement by not later than July 1, 1977, of effluent limitations for point sources, other than publicly owned treatment works, which are based on the application of the best practicable control technology currently available as defined by the Administrator pursuant to Section 304(b) of the Act. Section 301(b) also requires the achievement by not later than July 1, 1983, of effluent limitations for point sources, other than publicly owned treatment works, which are based on the application of the best available technology economically achievable which will result in reasonable further progress toward the national goal of eliminating the discharge of all pollutants, as determined in accordance with regulations issued by the Administrator pursuant to Section 304(b) of the Act. Section 306 of the Act requires the achievement by new sources of a Federal standard of performance providing for the control of the discharge of pollutants which reflects the greatest degree of effluent reduction which the Administrator determines to be achievable through the application of the best available demonstrated control technology, processes, operating methods, or other alternatives, including, where practicable, a standard permitting no discharge of pollutants.

Section 304(b) of the Act requires the Administrator to publish, within one year of enactment of the Act, regulations providing guidelines for effluent limitations setting forth the degree of effluent reduction attainable through the application of the best practicable control technology currently available and the degree of effluent reduction attainable through the application of the best control measures and practices economically achievable, including treatment techniques, process and procedure innovations, operation methods and other alternatives. The regulations proposed herein set forth effluent limitations guidelines pursuant to Section 304(b) of the Act for the soap and detergent industry.

Section 306 of the Act requires the Administrator, within one year after a category of sources is included in a list published pursuant to Section 306(b) (1) (A) of the Act, to propose regulations establishing Federal standards of performances for new sources within such categories. The Administrator published in the Federal Register of January 16, 1973 (38 F.R. 1624), a list of 27 source categories. Publication of the list constituted announcement of the Administrator's intention of establishing, under Section 306, standards of performance applicable to new sources within the soap and detergent category, which was included within the list published January 16, 1973.

### Limitations Guidelines and Standards of Performance

The effluent limitations guidelines and standards of performance proposed herein were developed in the following manner. The point source category was first categorized for the purpose of determining whether separate limitations and standards are appropriate for different segments within a point source category. Such subcategorization was based upon raw material used, product produced, manufacturing process employed, and other factors. The raw waste characteristics for each subcategory were then identified. This included an analysis of (1) the source and volume of water used in the process employed and the sources of waste and waste waters in the plant; and (2) the constituents (including thermal) of all waste waters including toxic constituents and other constituents which result in taste, odor, and color in water or aquatic organisms. The constituents of waste waters which should be subject to effluent limitations guidelines and standards of performance were identified.

The full range of control and treatment technologies existing within each subcategory was identified. This included an identification of each distinct control and treatment technology, including both inplant and end-of-process technologies, which are existent or capable of being designed for each subcategory. It also included an identification in terms of the amount of constituents (including thermal) and the chemical, physical, and biological characteristics of pollutants, of the effluent level resulting from the application of each of the treatment and control technologies. The problems, limitations and reliability of each treatment and control technology and the required implementation time was also identified. In addition, the non-water quality environmental impact, such as the effects of the application of such technologies upon other pollution problems, including air, solid waste, noise and radiation were also identified. The energy requirements of each of the control and treatment technologies was identified as well as the cost of the application of such technologies.

The information, as outlined above, was then evaluated in order to determine what levels of technology constituted the "best practicable control technology currently available," "best available technology economically achievable" and the "best available demonstrated control technology, processes, operating methods, or other alternatives." In identifying such technologies, various factors were considered. These included the total cost of application of technology in relation to the effluent reduction benefits to be achieved from such application, the age of equipment and facilities involved, the process employed, the engineering aspects of the application of various types of control techniques, process changes, non-water quality environmental impact (including energy requirements) and other factors.

The data for identification and analyses were derived from a number of sources. These sources included EPA research information, published literature, a voluntary industrywide audit, an extensive industry plant effluent sampling program, qualified technical consultation, and on-site visits and interviews at exemplary soap and detergent processing plants throughout the United States. All references used in developing the guidelines for effluent limitations and standards of performance for new sources reported herein are included in Section XIII of this document.

### General Description of the Industry

This industrial category is covered under Standard Industrial Code 2841 and includes establishments primarily engaged in the manufacture of soap, synthetic organic detergents, inorganic alkaline detergents, or any combination. Crude and refined glycerine from vegetable and animal fats and oils are also included. Excluded from this category are establishments primarily engaged in manufacturing shampoos or shaving products and synthetic glycerine. Also excluded are specialty cleaners, polishing and sanitation preparations.

### Historical

The industry which produces products for cleaning of fabrics, dishes, and hard surfaces goes back to the earliest recorded history. Clay tablets found in ancient Mesopotamia dating back to the third millenium B.C., gave a soap recipe calling for a mixture of potash and oil to be used in the making of cloth. Modern soap and synthetic detergent formulations and business practices were shaped by a series of events which started in the 1930s. These include the introduction of synthetic surface active ingredients in the mid 1930s. There followed the war-induced shortage of the natural ingredients for soap making such as tallow and coconut oils and the consequent rapid increase then in the use of synthetics.

The discovery of polyphosphate builders followed, which made synthetic laundry products suitable replacements for soap. The scramble of soap and detergent companies for the housewives' favor occurred during the 1950s and determined market shares of companies in the household segment even today. Finally, there began the formulation of detergent products to meet environmental considerations.

The first environmental reformulation consisted of a voluntary industry switchover to more biodegradable linear benzene sulfonate surfactants to replace the original highly branched, poorly degradable benzene sulfonates in the 1960s. Shortly thereafter the use of phosphate builders in detergents came under attack from environmentalists. Of the 3 nutrients, phosphorus, nitrogen and carbon, which cause eutrophication of lakes, phosphorus appears to be the only nutrient amenable to control.

A series of events led to today's confusing and indeterminate situation vis-a-vis phosphate builders. Nitrilotriacetic acid use was begun and then stopped because of fears over teratogenicity. Detergents built with carbonates and silicates were introduced and then somewhat squelched because some of the products represented alkalinity hazards and there were also problems such as interference with flame retardancy, and deposition of hard water reaction products on clothes. Today the search for a safe, effective builder to replace phosphate continues in full swing with citrates and multifunctional compounds such as carboxy methylene oxy succinate getting much research effort. Other detergent ingredients have also been the subject of concern as to their safety and environmental impact. Enzymes are an example, and sales of enzyme-containing detergents suffered for a time as a result.

### Companies and Markets

The household detergent industry is dominated by three large companies. The largest U.S. company has about one half of the U.S. sales and production. The next two companies in size each have about one sixth of the U.S. market. The remaining 17 percent of the business is shared by over 300 companies. Very few companies beyond the five largest produce and market products across the country. The smaller companies captured an appreciable portion of the market share of the big three with non-phosphate detergents before bad publicity put a damper on sales of phosphate-free laundry detergents.

Laundry detergents are the largest category of products made by the soap and detergent industry. The number one selling brand has held about a 25 percent share of the U.S. market for over two decades. This brand is the industry standard for this category of product and the market leader fights hard to maintain his level of sales of household detergents. Other detergent companies constantly search for improved products containing better ingredients so they can get a bigger share of this market. The cost of the search for new and improved products has increased greatly because of the more sophisticated safety and environmental approaches now needed.

In considering other household cleaning products, it will be noted that the big three producers have a less dominant position. Liquid hand dishwashing detergents are next to laundry detergents in importance. Although the largest companies do dominate this market there are many private label products sold by supermarket chains and also quite a number of brands marketed by smaller companies. The liquid hand dishwashing detergent market is static in growth because of the constant shift toward home automatic dishwashers.

Automatic dishwashing detergents are produced in sizable amounts by medium and small sized firms as well as the larger detergent companies. This category of product has grown very rapidly with

TABLE 1  
SUMMARY VALUE OF SHIPMENTS AT MANUFACTURERS LEVEL  
SOAPS AND DETERGENTS SIC 2841  
AFTER 1967 CENSUS OF MANUFACTURERS (ADJUSTED)

	<u>1963</u> (in millions)			<u>1967</u> (in millions)			<u>1973</u> (in millions)		
	<u>Kilograms</u>	<u>Pounds</u>	<u>Dollars</u>	<u>Kilograms</u>	<u>Pounds</u>	<u>Dollars</u>	<u>Kilograms</u>	<u>Pounds</u>	<u>Dollars</u>
All Soaps	<u>605.1</u>	<u>1332.8</u>	<u>355.0</u>	<u>563.1</u>	<u>1240.3</u>	<u>383.9</u>	<u>540.4</u>	<u>1190.4</u>	<u>415.1</u>
Glycerine									
Natural	63.6	140.0	26.0	65.8	145.0	36.0	68.1	150.0	35.0
Alkali									
Detergents	519.0	1143.2	200.2	670.1	1476.0	279.6	887.6	1955.0	384.5
Acid Type									
Cleaners	156.1	343.8	35.2	256.1	564.0	61.7	398.6	878.0	100.7
Synthetic									
Org. Det.									
Household	2098.7	4622.7	1029.4	2513.5	5536.4	1235.4	3169.9	6982.2	1565.0
Synthetic Org.									
Det. Non-									
Household	287.2	632.6	115.3	357.5	787.4	141.1	443.1	976.0	167.0
Soap and Other									
Det. NSK	38.6	85.0	17.6	166.2	366.0	73.2	332.3	732.0	146.4
Grand Total									
Soaps and									
Detergents	3768.3	8300.1	1778.7	4592.3	10115.1	2210.9	5840.1	12863.6	2813.7



the proliferation of the home automatic dishwasher. With only a third of the nation's households having automatic dishwashers great growth can be expected to continue.

Household specialty cleaners of all types are produced by hundreds of companies in successful competition with the big three. This is possible because the specialties require less capital investment than spray dried laundry detergents. Also, specialties are amenable to smaller and localized marketing and advertising programs.

As opposed to the production of detergents, the soap producing segment of the industry is now concerned primarily with the production of toilet bars. A modest amount of soap is used in synthetic household detergent manufacture, both in heavy duty solid formulations and in combination detergent - soap bars. There is a possibility of a moderate increase in the marketing of laundry soap if more local ordinances prohibiting the use of detergents were to be passed. For a number of economic reasons, for example, the doubling of the cost of natural fats and oils used in soap manufacture within the last year alone, it seems unlikely that soap sales will increase significantly from their present levels.

The largest sales of bar soaps are again made by the three largest companies. In general, other soap companies specialize in private label, specialty soaps, and institutional sales.

Glycerine is an important product of the industry. It is made as a by-product of soap production, and synthetically from petroleum-derived propylene. Glycerine is an important cosmetic and food intermediate and many soap and detergent companies are also in these businesses. Synthetic glycerine competes with the naturally derived product. Its synthesis bears no relationship to the fat-derived product, but in composition it is essentially identical.

Glycerine is a mature chemical whose use is presently growing at the rate of 3 percent a year. The total 1972 estimated U.S. production was 158 million kilograms (348 million lb) with exceptionally high exports accounting for 29 million kilograms (64 million lb). Synthetic glycerine (not included in SIC 2841) is estimated to have accounted for approximately 91 million kilograms (200 million lb) of the total production in 1972 with natural glycerine production accounting for 68 million kilograms (150 million lb). There are 3 new fat splitting plants under construction in the U.S. which will give 3 new sources of by-product glycerine.

#### Industrial Cleaning Compounds

Industrial cleaning compounds are also an important part of this industry. Compounds are made for metal cleaning, textile processing, food sanitation, and a host of other applications.

Total dollar value of the non-household cleaning market was \$263 million in 1967 and is estimated at \$373 million for 1973. There are a host of small companies and divisions of large companies in this business area. Most producers, though, serve a limited market and a limited geographical area.

### Sales and Production

Table I gives an estimate of dollar values and poundage produced for the products comprising SIC 2841. It is interesting that the oldest product, soap, still securely retains an important market; that is, toilet and bath bars. Automatic dishwashing detergents are growing rapidly and these products are even more vitally affected by the phosphate controversy than are laundry detergents.

### Physical Plant

In general, the soap and detergent industry has not integrated backwards toward their raw materials. Basic raw materials come from a host of supplier companies. Caustic, fats, and oils for soap making come from chemical and agricultural processors, although some companies do own coconut plantations. Detergent alkylate, alcohols and non-ionic surfactants usually come from large chemical and petrochemical companies. Some anionic surfactant is also produced by suppliers, but in general the soap and detergent companies do most of their own sulfation and sulfonation. The inorganic builders and other additives come exclusively from supplier companies.

The three largest companies in the household market have plants in major metropolitan areas across the country. Not only are distribution costs important, but also the large volume of products makes it possible for one company to build economical sized plants in a number of locations. There are about 30 major plants for production of heavy duty laundry detergents in the United States.

### Trade Practices

It is fairly common for the major companies to contract with other companies for toll processing. In these arrangements the soap and detergent company will buy synthetic detergent bases, send them to a second company for reaction, and have the product returned for further compounding. For example, detergent alcohols may be bought by a soap and detergent company and then toll ethoxylated by a petrochemical company and returned to the soap and detergent company for further processing.

Another business arrangement is the production of packaged detergents by private label producers which are then sold by the major food chains under their own brand names.

The capital requirements for a spray dried detergent bead plant limit the number of these units. To be competitive, these complexes produce volumes on the order of 13,620 kg per hour (30,000 lb per hour) and cost up to 10 million dollars. Soap making equipment can be fairly capital intensive, especially the newer fat splitting and fatty acid purification processes. Production of light-duty liquid detergents and dry blended products require less capital and consequently many more producers are found. Freight is an important consideration in shipping liquids.

### Industry Problems

Foremost in difficulty is the phosphate problem. Large sums of money have been spent both by detergent companies and by their suppliers to find phosphate replacements. To date, no replacement has been found which is entirely safe, effective, and economically feasible. Generally, companies are reformulating with lower phosphate levels, substituting nonionic for anionic organic surfactants, and using additional amounts of alkaline builders like sodium carbonate and sodium silicates.

New product development is not as frequent and fruitful as in the past. It is much more difficult to produce new products which meet environmental requirements, so development money leads to fewer products.

An appreciable portion of the waste load encountered in soap and detergent manufacturing is attributable to general practices within the industry. The industry is strongly oriented to sales promotion, with sales promotion frequently pitched to emotion or aesthetic factors which have little or no affect on product performance. This has led to great variety in things such as color, scent and opacity which produce the need for frequent cleanouts to avoid cross contamination and result in generation of added waste loads.

### Future Trends

The industry is growing at a rate of 5 percent per year. It is secure in the knowledge that its products are vitally necessary. The relative standing of various industry members depends upon how successfully they solve environmentally actuated formulation problems.

### SOAP PROCESS DESCRIPTIONS

Each of the following process descriptions are associated with a process flow sheet. All of the expected waste water effluents are identified in the flow sheet by name and code number for quick reference.

#### SOAP MANUFACTURE BY BATCH KETTLE (101)

Most of the soap made by this process finds its way into toilet bar form for household usage. This use demands freedom from offensive odors, and displeasing colors. In order to meet this requirement, the starting fats and oils must be refined. There is a direct relationship between quality of the fats and the quality of the finished soap.

### Fat Refining and Bleaching

There are several ways in which fats are refined. One of the most frequently used methods employs activated clay as the extraction agent. Activated clay, having a large ratio of surface area to weight, is agitated with warm oil and filtered. Color bodies, dirt, etc., are removed, usually through a plate and frame press. The clay is disposed of as solid waste. A small amount of clay remains in the refined fat.

The clay is often "activated" by being given an acid treatment itself by the clay supplier and is a source of sulfate ion build-up in some soap recycling streams.

Other ways in which fats are refined include caustic extraction, steam stripping and proprietary aqueous chemicals.

When soap accounted for the major portion of the soap and detergent market, the Solexol process of extraction found use in refining of fats and oils. The design of this liquid propane extraction process is based on the diminishing solubility of fats in liquid propane with increasing temperature. The fats are completely miscible at 48.84 C (120 F) but become almost insoluble at 82.14 C (180 F) and most of the color bodies precipitate.

Color bodies fall to the bottom of the treating tower while decolorized oils dissolved in liquid propane sit on the solvent (liquid propane) layer and are recovered from the top. This process is not now used in the United States, but should be reexamined since it offers a way to eliminate water use and thus could again become economical as discharges must be reduced.

### Soap Boiling

Although a very old process, kettle boiling still makes a very satisfactory product and in several well integrated manufacturing plants this process has a very low discharge of waste water effluents.

Making a batch of neat soap (65 - 70 percent soap in water) can take as long as four to six days to complete. A series of large steel tanks are used in a counter current manner to "boil" soap. Their capacity can be as high as 54,480 kilograms (120,000 pounds) of ingredients. Ever weakening caustic streams are met by enriched fat so that the caustic is essentially exhausted in the presence of fresh fat. In actual practice the fat never

### 101 SOAP MANUFACTURE BY BATCH KETTLE

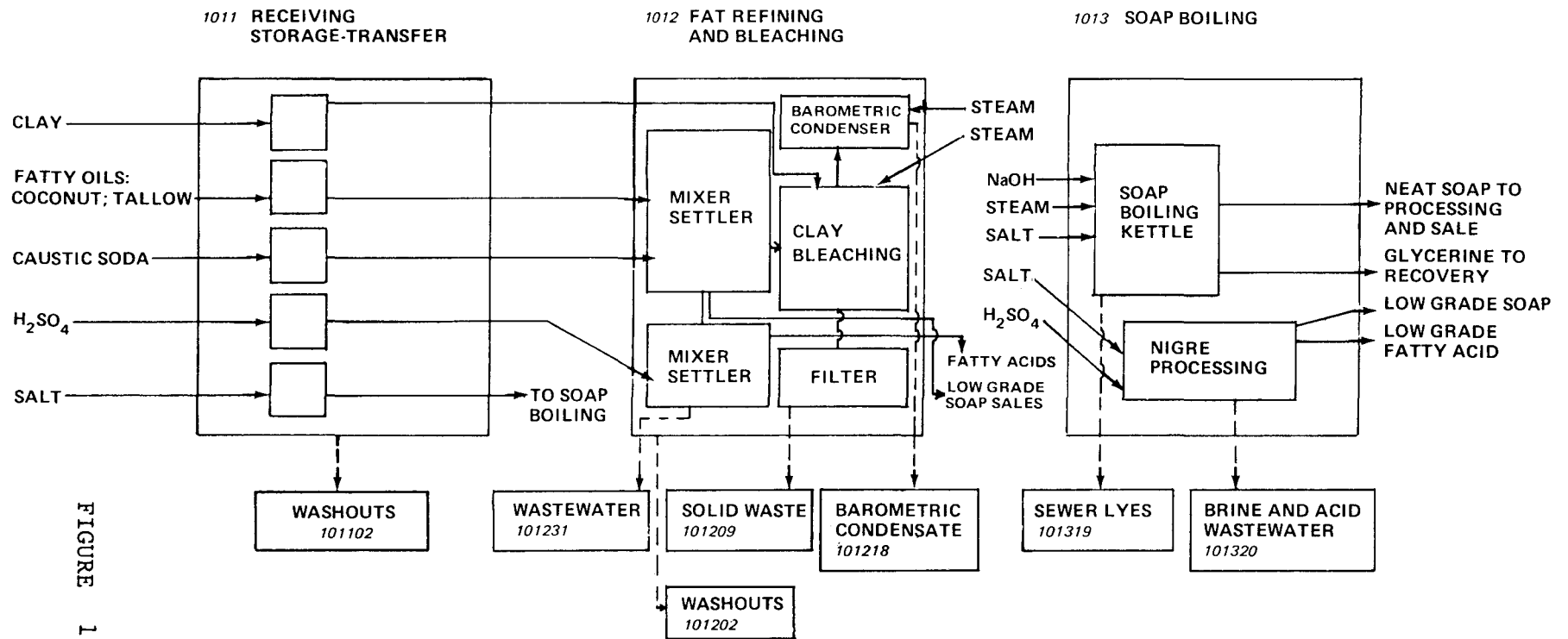

FIGURE 1

leaves the tank in which it starts until it is converted into neat soap. Just the aqueous caustic stream flows from tank to tank.

A simplified process description for kettle boiling soap follows:

Step 1 weigh in fats & oils and alkali	Step 2 turn on steam and saponify	Step 3 add salt and boil for graining	Step 4 turn off steam and settle
Step 5 drain off spent lye and send to recovery	Step 6 add water to kettle and boil closing	Step 7 add strong alkali to closed soap	Step 8 settle and run off lye to Step 1
Step 9 add water and heat to close soap for filling change	Step 10 settle and draw off neat soap	Step 11 recycle bottom nigre to Step 1	Neat Soap

Step 1 - Fats and oils are weighed in. The caustic stream from the "extreme change" of step 7 is run in as well as the nigre from step 11.

Step 2 - Live steam is customarily released into the kettle where it not only heats up the materials but also performs the stirring function. About three or four hours are consumed in this step.

Step 3 - Graining is the act of separating the newly formed soap from the exhausted lye solution. An operator adds salt or salt solution until a sample withdrawn with a trowel separates distinctly into soap and lye. About 10 - 12 percent NaCl is required.

Step 4 - About four hours are needed to completely settle the contents into two layers.

Step 5 - The spent lye contains 7 - 8 percent glycerine and is sent to the glycerine recovery unit.

Step 6 - "closed soap" is now made by adding fresh water to the kettle and heating it to make a continuous creamy material, dissolving the remaining glycerine and salt.

Step 7 - The "strong change" is carried out by adding fresh, concentrated lye which saponifies the last remnants of fat. The batch is brought to a boil again, water is added until the soap

is closed, then the lye is run in. Since the soap is not soluble in the strong alkali it becomes grainy.

Step 8 - Steam is shut off and the batch allowed to settle for three hours. The lye is run off and added to a beginning batch in the "extreme kill."

Step 9 - Heating is again begun and water run in until the mass is closed and boiling is continued until the soap removed on a trowel can be poured off in a transparent sheet.

Step 10 - Heat is turned off and the batch is allowed to settle. Neat soap is drawn off the top and run off to be processed into one of many forms of soap products. The lower layer is the nigre which contains the color bodies, dark soap, etc. It contains as much as 20 - 25 percent of the kettle contents (30 - 40 percent soap). When the nigre becomes heavily loaded with impurities it can itself be salted out, making a low grade soap for sale.

Step 11 - Frequently the nigre is recirculated to the kettle for the start of a new batch.

An overall schematic of the soap-making process is as follows:

The waste water from kettle boiling is essentially from the nigre stream. The nigre is the aqueous layer which contains the color bodies generated in the soap making process, mostly dark soaps. They are often marketed as industrial lubricants or low grade special purpose soaps. Where such a market can be established a kettle boil soap process is already at the zero discharge effluent level except for the oil refining step.

#### Salt Usage

In order to maintain suitable solubility for proper processing, salt is added to the soap making process to maintain the required electrolytic balance. Most of the salt charged into the process is ultimately returned to it from the glycerine concentration step, which will be discussed later. Practically every kettle boiling soap manufacturer concentrates his glycerine stream, although only a few go on to the distillation of glycerine.

#### FATTY ACID MANUFACTURE BY FAT SPLITTING (102)

By means of fat splitting very low grade fats and oils are upgraded to high value products by splitting the glycerides into their two components, fatty acids and glycerine. Fat splitting is an hydrolytic reaction which proceeds as follows:



Using a Twitchell catalyst (an aromatic sulfonic acid) and a long residence time, fats can be split at nearly atmospheric

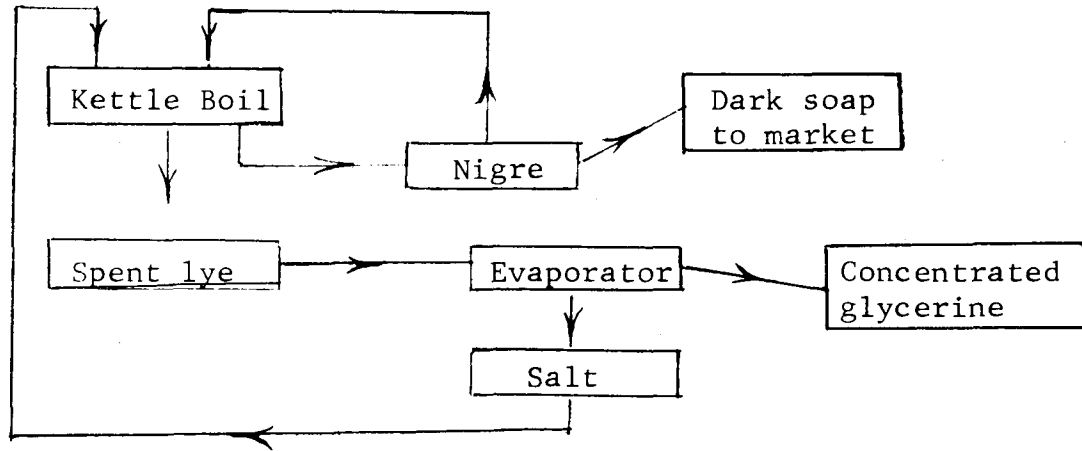

SOAP MAKING

FIGURE 2



pressures. Today, however, most fat splitting takes place in a high pressure, high temperature tower operated at around 34 atm and 260°C (500 psig and 500°F).

Heated fat, 254°C (490°F) and under pressure, is fed into the bottom of the tower and water, 204°C (400°F) and also under pressure, is fed into the top. The two streams mix counter-currently and hydrolysis takes place, often in the presence of a zinc or tin catalyst. At the high temperatures employed the fat is soluble to the extent in 12 - 25 percent of water, depending upon which fat is used.

In about 90 minutes the splitting can be as high as 99 percent complete. The glycerine by-product can be produced at a variety of concentrations depending upon how complete a fat hydrolysis is desired. More concentrated glycerine can be provided at some expense of fatty acid yields.

The crude acids are flashed in a pressure reducer and then distilled at 0.0026 - 0.0039 atm (2 - 3 mm) pressure. The resulting product may be subjected to an additional process step of flash hydrogenation to reduce the amount of unsaturated acids.

#### SOAP FROM FATTY ACID NEUTRALIZATION (103)

Soap making by fatty acid neutralization exceeds the kettle boil process in speed and minimization of waste water effluent. Although widely used by the large soap producers, it is also very popular with the smaller manufacturer.

This route from the acids is faster, simpler (no by-product dilute glycerine stream to handle) and "cleaner" than the kettle boil process. Distilled, partially hydrogenated acids are usually used.

The fatty acid neutralization process has several additional advantages over the kettle boiling process. It does not have a large salt load to recycle, and has a free alkali concentration in the order of 0.1 - 0.2 percent, contrasted with around 1 percent in the kettle boiling process.

The reaction that takes place is substantially:



Often, sodium carbonate is used in place of caustic with the attendant evolution of carbon dioxide. When liquid soaps (at room temperature) are desired, the more soluble potassium soaps are made by starting with potassium hydroxide. The potassium soaps are used in the familiar liquid hand soap dispensers, in many industrial applications, and often as lubricants.

As in kettle boiling soap manufacture, the most popular mix of acids for bar soap is in the ratio of 20:80 20/80 coconut

## 102 FATTY ACID MANUFACTURE BY FAT SPLITTING

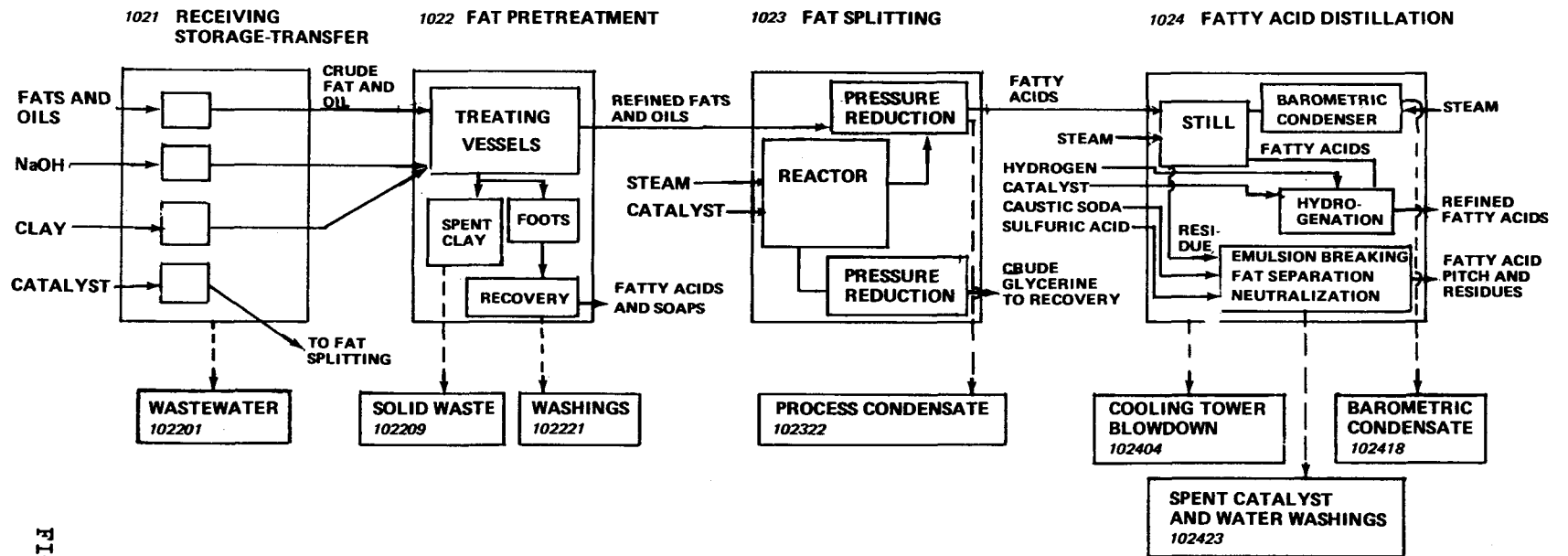

27

FIGURE 3

### 103 SOAP FROM FATTY ACID NEUTRALIZATION

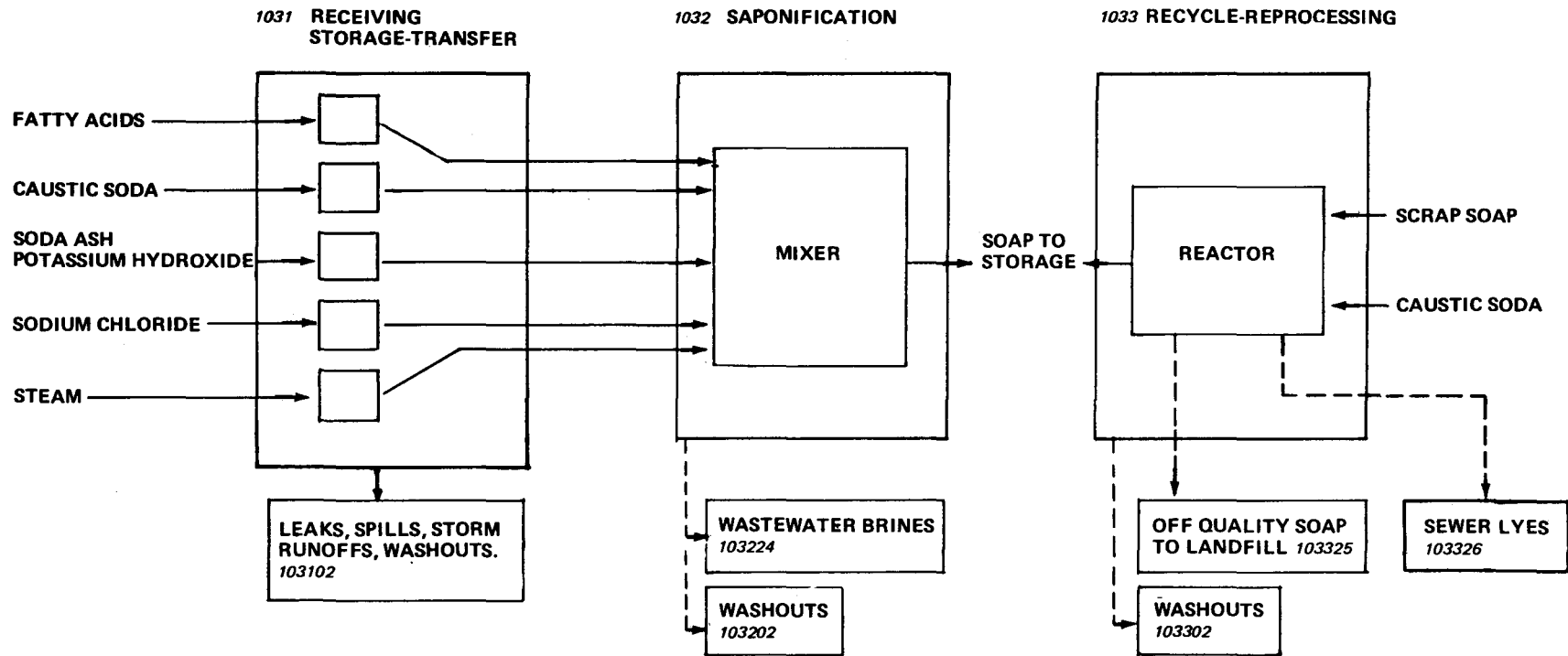

FIGURE 4

oil:tallow oil derived acids. A number of distilled tall oil soaps (tall oil is derived from the waste streams of paper manufacture) are also made for industrial purposes.

In some cases, the soap making process is operated continuously in tandem with a fat splitting process. The fatty acids and caustic solution are proportionated into a reactor continuously by pumps having a common variable speed drive. The appropriate amount of salt is also programmed in to maintain the correct electrolyte content.

The resulting neat soap will have about 30 percent moisture.

To clarify the soap solution, the soap stream coming out of the reactor is sometimes filtered with clay. The spent clay creates a certain amount of solid waste and the filter press is washed out occasionally. Otherwise this is a "clean" process.

The neat soap is further processed into bars or liquid formulations in the same manner as the product from kettle boiling.

#### GLYCERINE RECOVERY (104)

##### Concentration

The kettle boiling soap process generates an aqueous stream referred to as sweet water lyes. This stream will contain 8 - 10 percent glycerine, a heavy salt concentration and some fatty materials. It is processed by first adding a mineral acid (HCl) to reduce the alkalinity. This is followed by the addition of alum which precipitates insoluble aluminum soaps. The precipitate carries other impurities down with it. If the stream were not treated with alum, there would be severe foaming in the evaporators, and the contaminant would be carried forward into the glycerine. The cleaned up glycerine solution is sent to the evaporators.

The evaporators (in some smaller plants there will be only one) are heated under reduced pressure. The partial vacuum is generated by a barometric condenser. They frequently operate at 0.13 to 0.07 atm (660 mm - 710 mm or 26 - 28" Hg of vacuum).

As the glycerine is concentrated the salt comes out of solution and is removed from the evaporation kettle, filtered and returned to the soap making process. In many plants this separating function is performed continuously with a centrifuge with the filtrate being returned to the evaporator.

The glycerine is usually concentrated to 80 percent by weight and then either run to a still to be made into finished glycerine, or stored and sold to glycerine refiners.

### 104 GLYCERINE RECOVERY

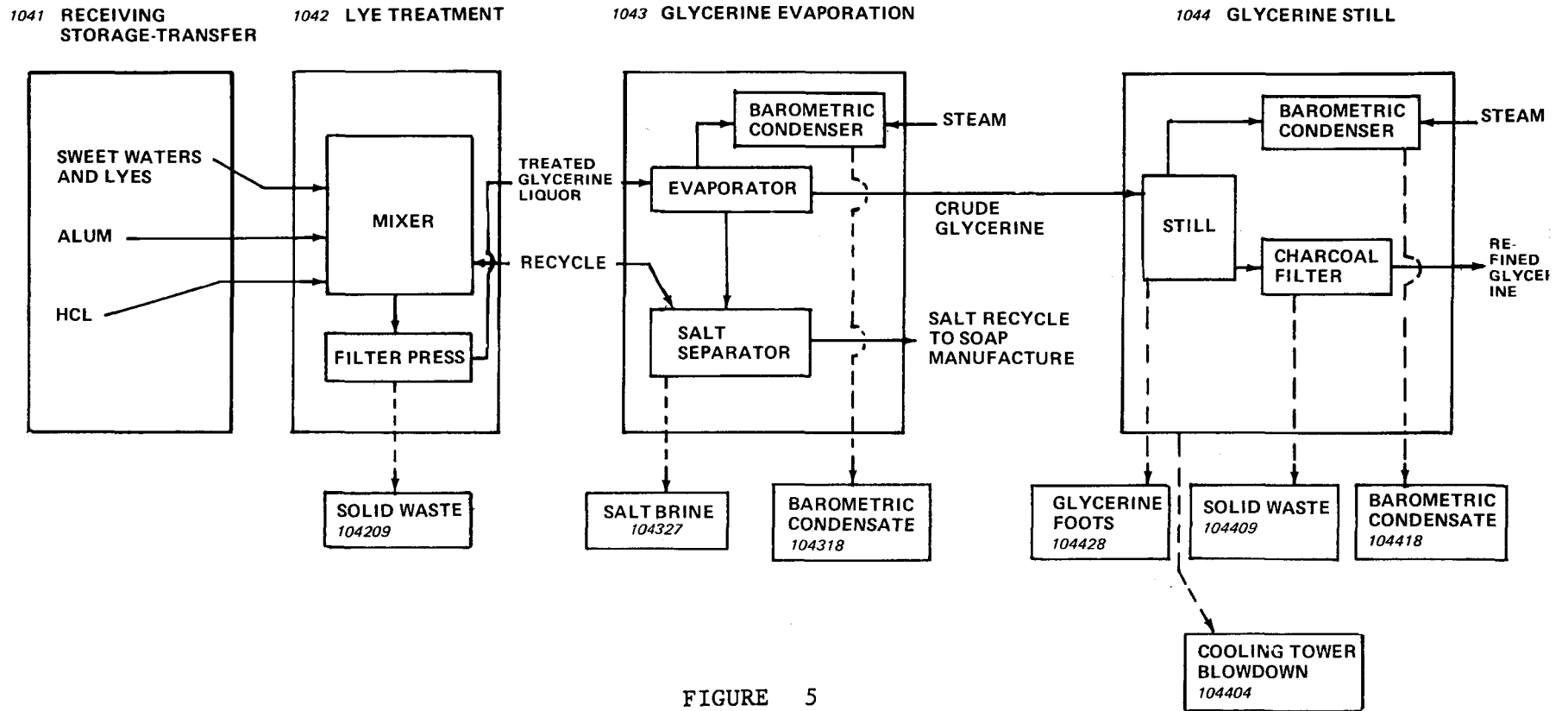

FIGURE 5

The sweet water glycerine from fat splitting is flashed to atmospheric pressure, thereby releasing a considerable amount of water very quickly. This can provide a glycerine stream of 20 percent glycerine or more going to the evaporators. Since there is no salt used in fat splitting there will be none in the sweet water.

The water from the barometric condenser used in concentrating will be slightly rich in BOD<sub>5</sub> due to the carryover of glycerine.

### Distillation

The concentrated glycerine (80 percent) is run into a still which, under reduced pressure, yields a finished product of 98+ percent purity. Here again a barometric condenser is used to create the partial vacuum.

At room temperature, the still bottoms (also called glycerine foots) are a glassy dark brown amorphous solid rather rich in salt. Water is mixed with the still bottoms and run into the waste water stream. This particular stream is very rich in BOD<sub>5</sub>, and readily biodegradable. Many alternative methods of disposal, including incineration, have been evaluated, but the general practice is disposal in a waste water stream.

The other waste water stream, the barometric condenser water, will also contribute to the total BOD<sub>5</sub>/COD load from the glycerine still.

Some glycerine refining is done by passing the dilute stream over ion exchange resin beds, both cationic and anionic, and then evaporating it to 98+ percent glycerine content as a bottoms product. This method is suitable where there are copious quantities of water available and energy costs are very high.

In the backwash of the ion exchange process the organic suspended solids are stripped from the system. The regeneration cycle of both types of beds will add a significant dissolved solids load to the waste water system.

There are frequently three sets, in series, of both cation and anion exchange resins used in this process. Each step is designed to reduce the input load by 90 percent. Some of the fat splitting plants are equipped with this type of unit.

### SOAP FLAKES AND POWDERS (105)

Neat soap (65 - 70 percent hot soap solution) may or may not be blended with other products before flaking or powdering. Neat soap is sometimes filtered to remove gel particles and run into a crutcher for mixing with builders.

### 105 SOAP FLAKES AND POWDERS

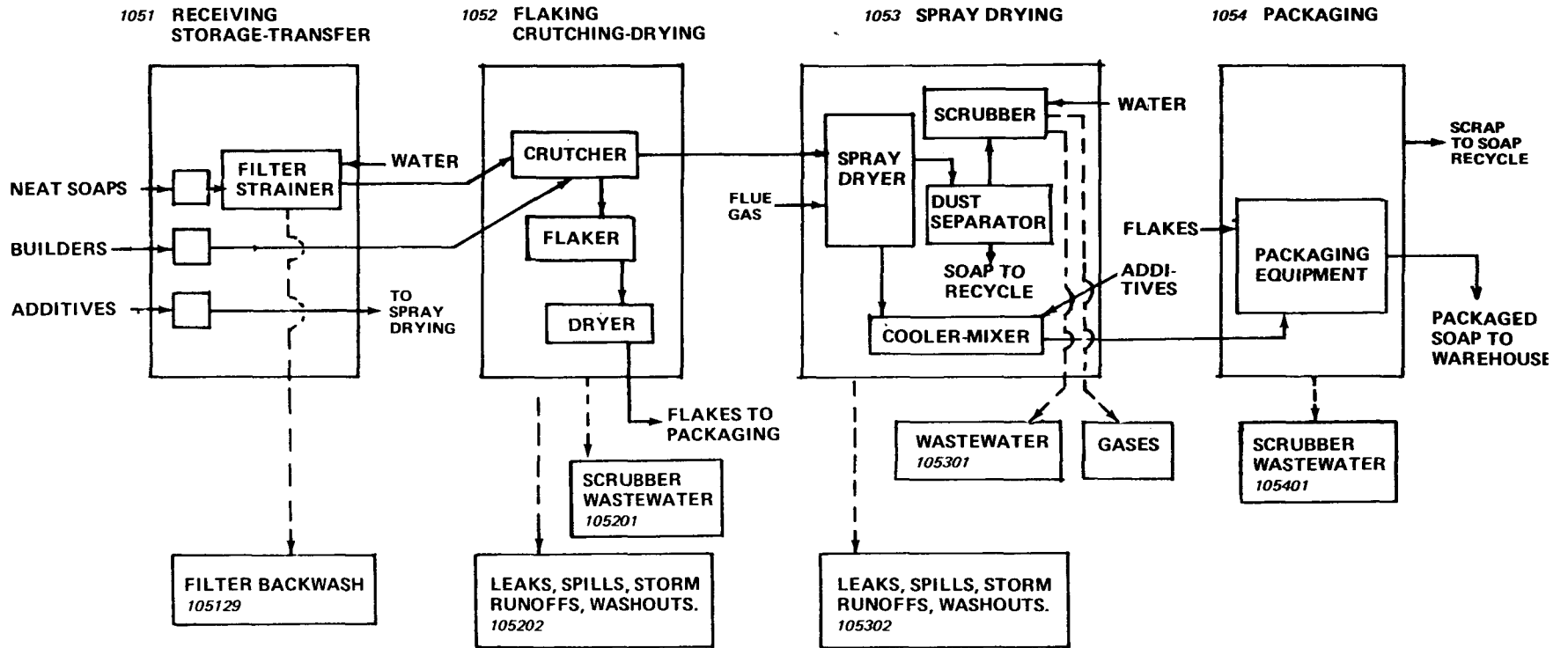

FIGURE 6

After thorough mixing, the finished formulation is run into a flaker. This unit normally consists of a two roll "mill" having two steel rolls. The small upper one is steam-heated while the larger lower one is chilled. The soap solidifies on the lower one and is slit into ribbons as it sheets off the roller.

The ribbons are fed into a continuous oven heated by hot air. The emerging flakes contain 1 percent moisture. As all of the evaporated moisture goes to the atmosphere, there is no waste water effluent.

In spray drying, crutched, heated soap solution is sprayed into a spray tower, or flash-dried by heating the soap solution under pressure and releasing the steam in the spray dryer under reduced pressure. In either case the final soap particle has a high ratio of surface area to unit of weight, which makes it readily dissolvable in water.

Some operations will include a scrap soap reboil to recover reclaimed soap. The soap reboil is salted out for soap recovery and the salt water is recycled. After frequent recycling the salt water becomes so contaminated that it must be discharged to the sewer.

Occasional washdown of the crutcher may be needed. The tower is usually cleaned down dry. There is also some gland water which flows over the pump shaft picking up any minor leaks. This will contribute a very small, but finite, effluent loading.

#### BAR SOAP (106)

The procedure for bar soap manufacture will vary significantly from plant to plant, depending upon the particular clientele served. The following description typifies bar soap manufacture.

In some processes additives are mixed with the neat soap in a crutcher before any drying takes place. Another approach is to begin the drying process with the hot neat soap going to an "atmospheric" flash dryer followed by a vacuum drying operation in which the vacuum is drawn by a barometric condenser. Soap is then double extruded into short ribbons or curls and sent to plodders for further blending or physical processing. At this point the soap will normally have 8 - 14 percent moisture depending upon the previous course of processing.

Next, a milling operation affords the opportunity to blend in additives as well as modify the physical properties of the soap. This operation has much more significance than just achieving uniformity in the mixing of further added ingredients. The physical chemistry of soap is fairly complex. Unless a bar of soap is almost predominately left in the Beta phase, as distinct from the Omega phase, longrange solubility, warping resistance, and lathering properties are poor. Rapid chilling of the soap



# 106 BAR SOAPS

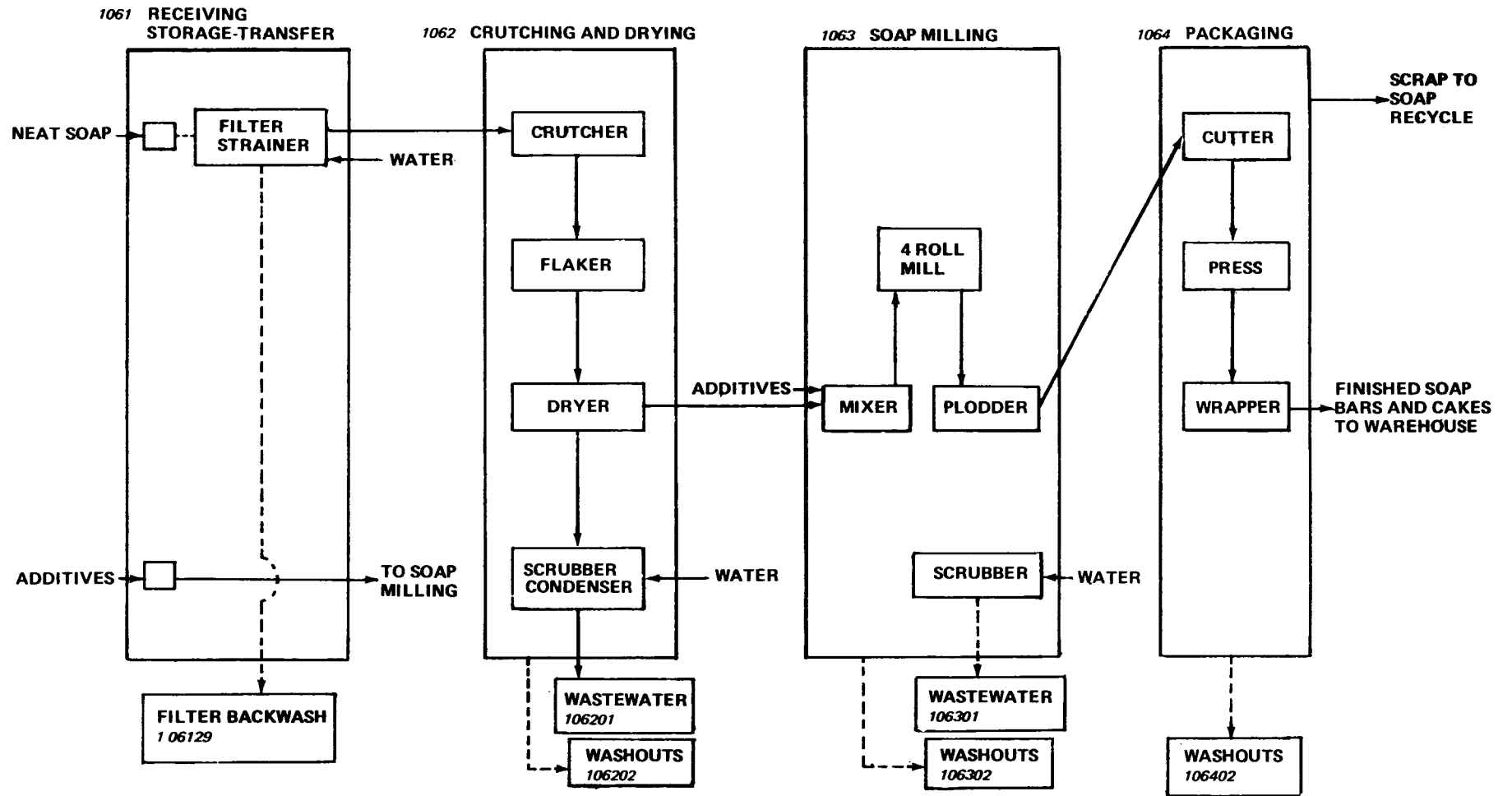

FIGURE 7

puts it predominantly in Omega phase but successive milling steps bring it back into Beta phase - hence the importance of milling.

The mill consists of two polished rolls rotating at different speeds to maximize the shearing forces. After milling, the soap is cut into ribbons and sent to the plodder.

The plodder operates much like a sausage grinder. It thus extrudes and cuts the soap into small chips, followed by further mixing in which all of the individual pieces are melted together into an homogeneous mass. The plodder is often operated under reduced air pressure so that any occluded air is removed in the blending process. It has a powerful screw that forces the soap through minute holes in a perforated plate.

Plodding completed, the soap is extruded continuously in a cylindrical form, cut to size, molded into the desired form, and wrapped for shipment. Most of the scrap in this operation is returned to the plodder.

At times there will be soap scrap which has become too dry to process properly in the plodder and it must be returned to earlier steps in the soap making process.

The amount of water used in bar soap manufacture varies greatly. In many cases the entire bar soap processing operation is done without generating a single waste water stream. The equipment is all cleaned dry, without any washups. In other cases, due to housekeeping requirements associated with the particular bar soap process, there are one or more waste water streams from air scrubbers.

Since we are dealing with a consumer product with very distinct (and important to the consumer) esthetic properties, all of these processes can claim significance and essential character in the making of a particular bar.

Occupying a very minor position in the soap market, a bar made from cold frame soap may be found. After the saponification reaction, this soap is poured directly from the reactor into molds. Upon cooling and the completion of saponification, the molded soap is cut into bars. The entire operation is carried out without the generation of any waste water.

#### LIQUID SOAP (107)

Neat soap (often the potassium soap of fatty acids) is blended in a mixing tank with other ingredients such as alcohols or glycols to produce a finished product, or with pine oil and kerosene for a product with greater solvency and versatility. The final blended product may be, and often is, filtered to achieve a sparkling clarity before being drummed.

### 107 LIQUID SOAP PROCESSING

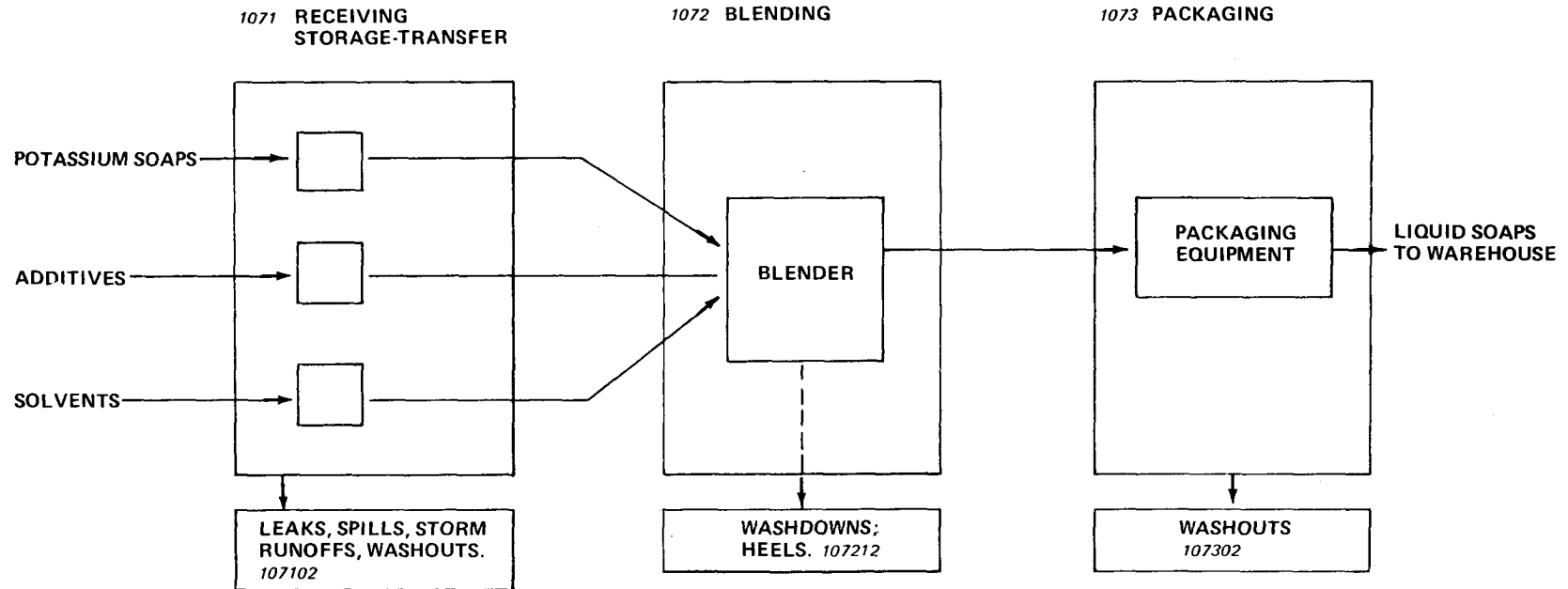

FIGURE 8

In making liquid soap, water is used to wash out the filter press and other equipment. Waste water effluent is minimal.

#### DETERGENT PROCESS DESCRIPTIONS

The first modern detergent introduced in the United States in 1933 was an alkyl naphthalene sulfonate. The primary reason for the success of detergents is their ability to overcome the hard water behavior of soaps. Even though the detergents also react with hard water minerals, the resulting compounds are themselves soluble, or remain colloiddally dispersed in the water system. There are four main groups of detergents:

Anionics  
Cationics  
Amphoterics  
Nonionics

Anionics comprise the most important group of detergents. They are usually the sodium salts of an organic sulfate or sulfonate. Sulfates are made from long chain "fatty alcohols" (of animal or petroleum origin). Sulfonates generally are made from alkyl aryl precursors.

By 1957 synthetic detergents took over 70 percent of the market for soap-like products in the United States.

Cationic detergents are known as "inverted soaps" because the long chain ion is of the opposite charge to that of a true soap when dispersed in water.

This class of detergents is made in quite small volumes. They are relatively expensive and somewhat harsh on the skin. They make excellent bacteriostats and fabric softeners and are used for this purpose.

Nonionic detergents are an increasingly popular active ingredient of automatic washing machine formulations. These products are unaffected by hard water (they do not form ions) and are very low foamers (minimum foam when agitated). They are made by the addition of ethylene oxide to an alcohol.

Amphoterics are those surface active agents which can either be anionic or cationic, depending upon the pH of the system wherein they work. An important class chemically, they account for only a very small portion of the detergent market.

#### DETERGENT MANUFACTURING PROCESSES

A finished, packaged detergent customarily consists of two main components, the active ingredient (surfactant) and the builder. The function of the surfactant is essentially that of wetting the substrate to be cleaned. The builder performs many functions including buffering the pH, soil dispersion, and soil anti-redeposition. Both classes of materials are required for proper detergent performance.

The processes described under this heading include the manufacture of the surfactant as well as preparation of the finished detergent. The number following the title of each process refers to the process flow chart.

#### OLEUM SULFONATION/SULFATION (201)

One of the most important active ingredients of detergents is the alcohol sulfate or alkyl benzene sulfonate - and particularly those products made via the oleum route.

In most cases the sulfonation/sulfation is carried out continuously in a reactor where the oleum (a solution of sulfur trioxide in sulfuric acid) is brought into intimate contact with the hydrocarbon or alcohol. Reaction is rapid. The stream is then mixed with water and sent to a settler.

Prior to the addition of water the stream is an homogeneous liquid. With the addition of water, two phases develop and separate. The dilute sulfuric acid is drawn off and usually returned to an oleum manufacturer for reprocessing up to the original strength. The sulfonated/sulfated material is sent on to be neutralized with caustic.

This process is normally operated continuously and performs indefinitely without need of periodic clean out. Pump glands occasionally leak. Anticipating this problem, a stream of water is normally played over pump shafts to pick up such a leak as it occurs, as well as to cool the pump. The flow of waste water from this source is quite modest but continual.

#### AIR-SO<sub>3</sub> SULFATION/SULFONATION (202)

This process for surfactant manufacture has numerous unique advantages and is used extensively. In the oleum sulfation of alcohols, formation of water stops the reaction short of completion because it reaches a state of equilibrium, resulting in low yields.

With SO<sub>3</sub> sulfation, no water is generated, hydrolysis cannot occur and the reaction proceeds in one direction only.

The absence of water in the SO<sub>3</sub> reaction is of a lesser importance in sulfonation. What is particularly troublesome in the use of oleum for alcohol sulfation is that water cannot be used for oleum separation due to the potential hydrolysis that

## 201 OLEUM SULFATION AND SULFONATION (BATCH AND CONTINUOUS)

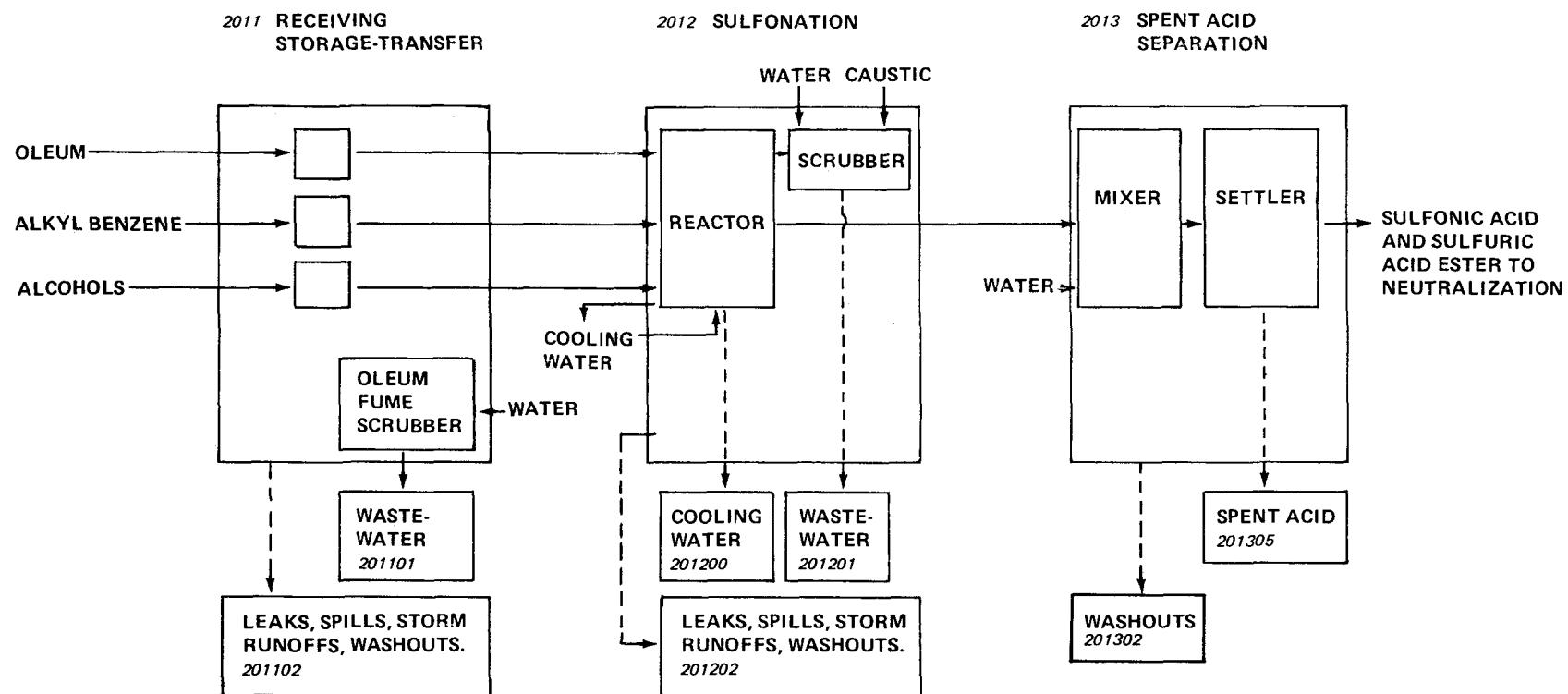

FIGURE 9

202 AIR-SO<sub>3</sub> SULFATION AND SULFONATION (BATCH AND CONTINUOUS)

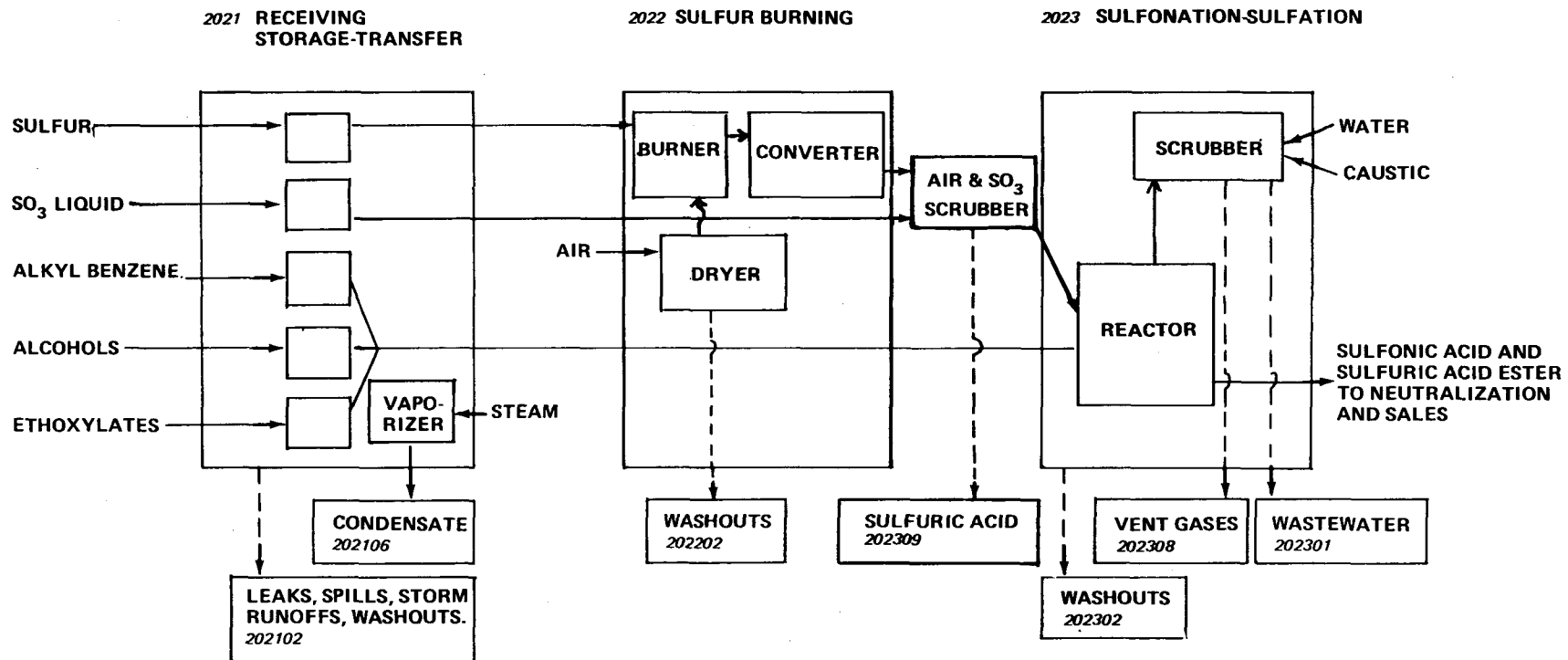

FIGURE 10

would take place. Even if this were not a worry, no phase separation of the components takes place with the addition of water to sulfated alcohols in oleum.

SO<sub>3</sub> sulfonation/sulfation is also quite amenable to batch processing and in this manner can produce products having a minimum of sodium sulfate (all of the excess of SO<sub>3</sub>, or sulfuric acid in the case of oleum sulfonation, will be converted into sodium sulfate in the neutralization step with caustic). Another advantage of the SO<sub>3</sub> process is its ability to successively sulfate and sulfonate an alcohol and a hydro-carbon respectively.

Care must be exercised in the SO<sub>3</sub> process to control reaction conditions - particularly temperature - to minimize char formation and possible sulfonation of the hydrocarbon chain of the alcohol.

Because of this reaction's particular tendency to char the product, the reactor system must be cleaned thoroughly on a regular basis. In addition there are usually several airborne sulfonic acid streams which must be scrubbed, with the waste water going to the sewer during sulfation.

SO<sub>3</sub> can be generated at the plant by burning sulfur or sulfur dioxide with air instead of obtaining it as a liquid. See the accompanying flow sheet for the process. For further technical information see Section X.

#### SO<sub>3</sub> SOLVENT AND VACUUM SULFONATION (203)

Undiluted SO<sub>3</sub> and organic reactant are fed into the vacuum reactor through a mixing nozzle (vacuum maintained at 0.06 atm (5" Hg)). Recycle is accomplished by running the flashed product through a heat exchanger back into the reactor. The main advantage of the system is that under vacuum the SO<sub>3</sub> concentration and operating temperature is kept low, thereby assuring high product quality. Offsetting this is the high operating cost of maintaining the vacuum.

#### SULFAMIC ACID SULFATION (204)

Sulfamic acid is a mild sulfating agent and is used only in very specialized quality areas because of the high reagent price. The system is of particular value in the sulfation of ethoxylates.

The small specialty manufacturer may use this route for making high quality alcohol sulfates, equivalent to that from the chlorosulfonic acid route, substituting high reagent cost for high capital costs of the chlorosulfonic route.

#### CHLOROSULFONIC ACID SULFATION (205)

For products requiring high quality sulfates, chlorosulfonic acid is an excellent agent. It is a mild sulfating agent, yields no



## 203 – SO<sub>3</sub> SOLVENT AND VACUUM SULFONATION

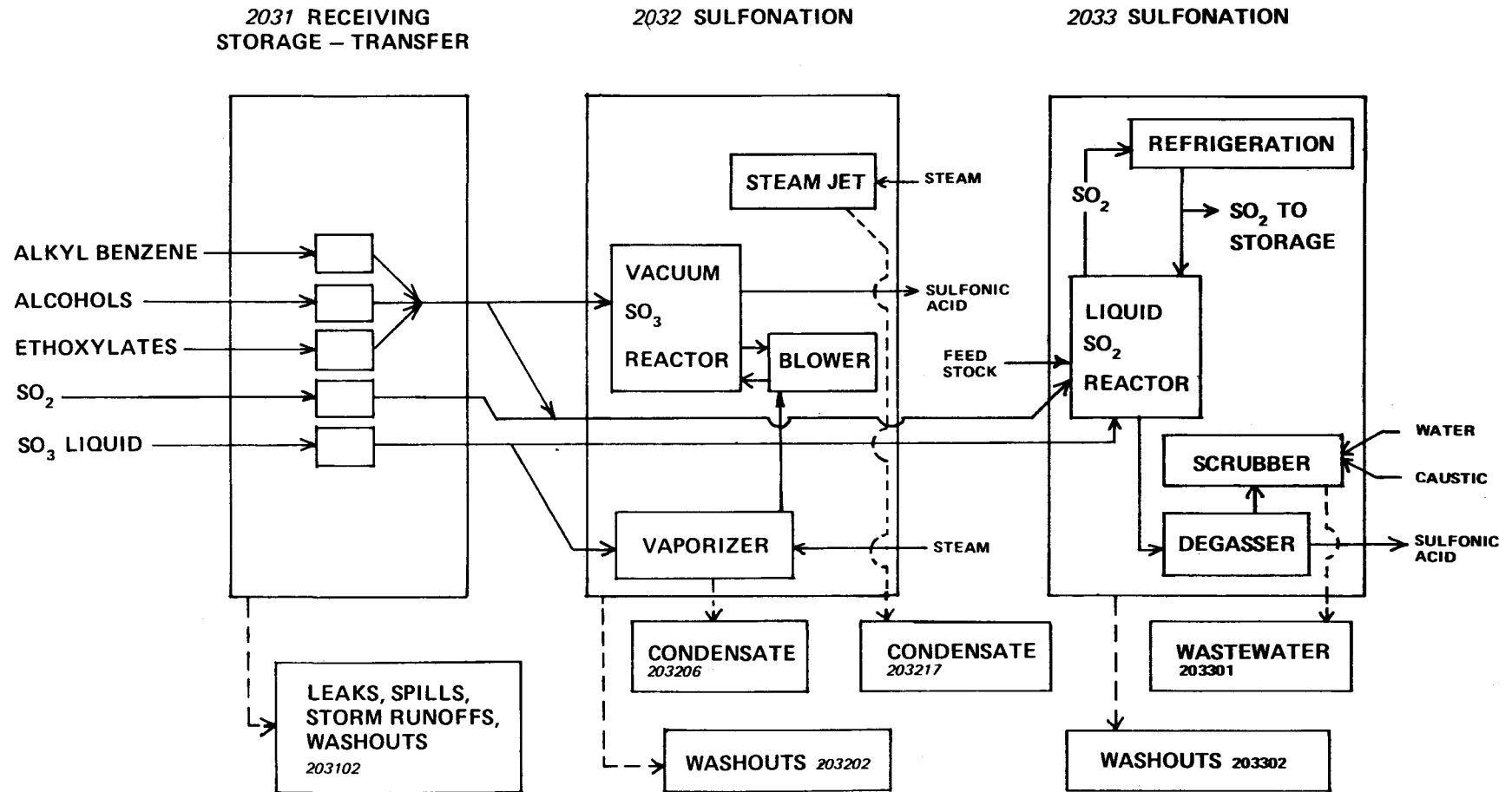

FIGURE 11

# 204 SULFAMIC ACID SULFATION

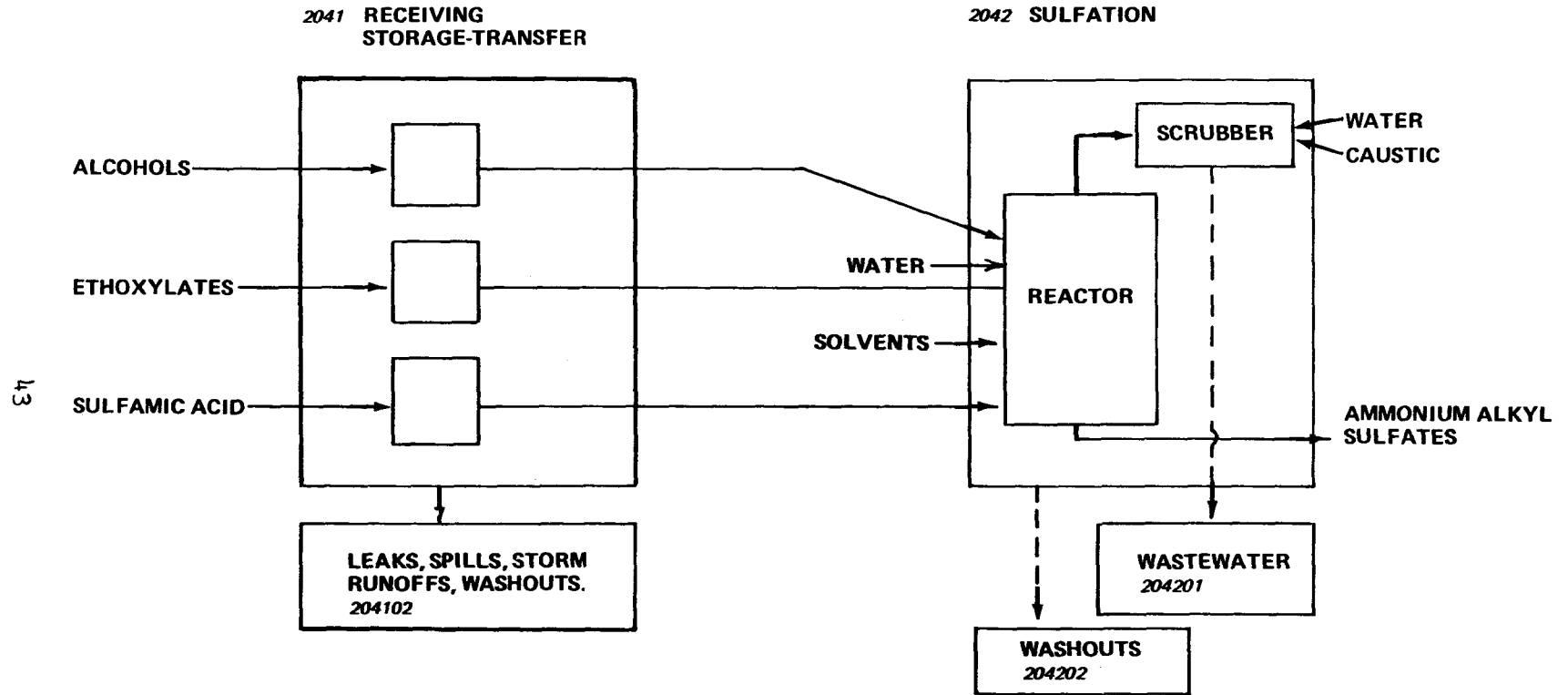

FIGURE 12

### 205 CHLOROSULFONIC ACID SULFATION

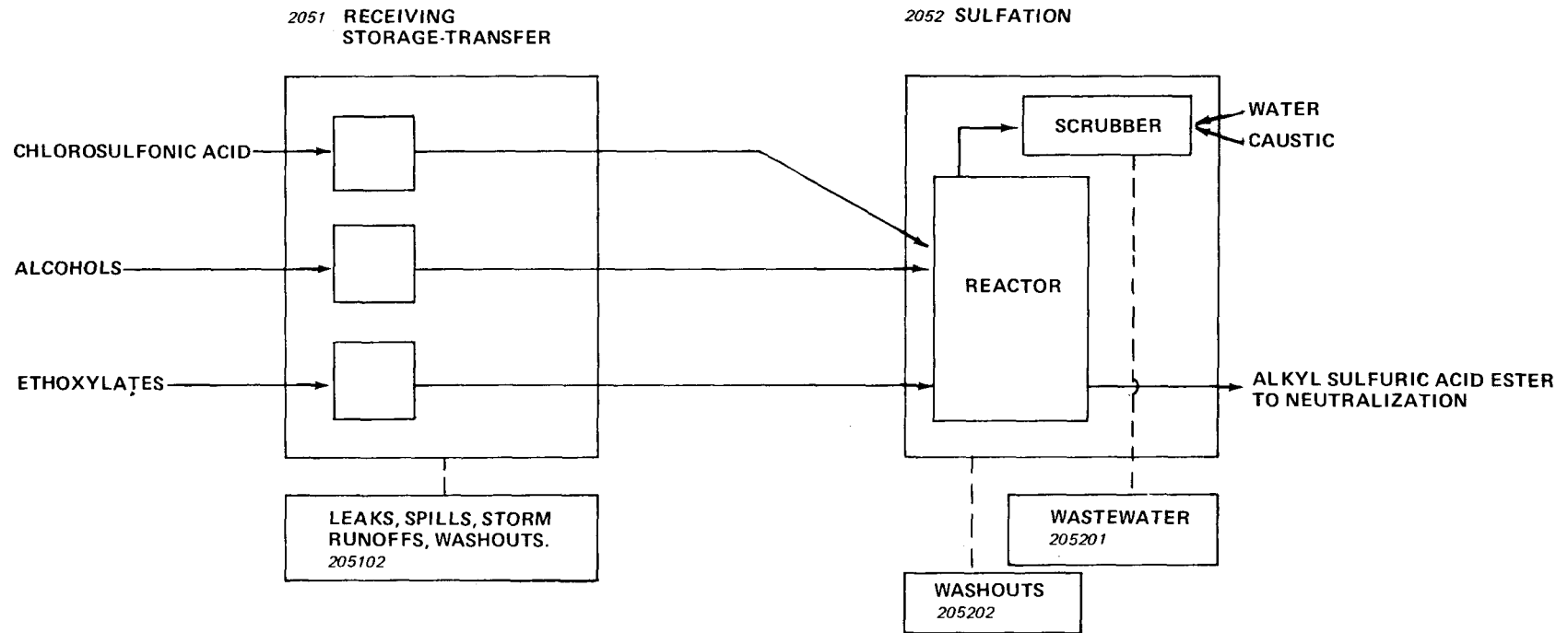

FIGURE 13

water of sulfation and generates practically no side reactions. It is a corrosive agent and generates HCl as a by-product.

An excess of about 5 percent chlorosulfonic acid is often used. It will yield an inorganic salt upon neutralization which is undesirable in some applications as it can result in salt precipitation in liquid formulations, etc.

#### NEUTRALIZATION OF SULFURIC ACID ESTERS AND SULFONIC ACIDS (206)

This step is essential in the manufacture of detergent active ingredients; it converts the acidic hydrophylic portion of the molecule to a neutral salt.

Alcohol sulfates are somewhat more difficult to neutralize than the alkylbenzene sulfonic acids due to the sensitivity to hydrolysis of the alcohol derivative. For this reason, neutralization is usually carried out at a pH above 7 and as rapidly as possible.

This is not a difficult feat for those who neutralize continuously, but it is more of a problem for the batch processor unless he has excellent stirring.

As a result of hydrolysis occurring in the neutralization step, there will be some free alcohol generated which would be picked up in the oil and grease analysis. As a product this is not all bad since the free alcohol can actually be considered a foam stabilizer in some situations. If used in heavy duty products, the alcohol tends to be lost in the spray tower.

#### SPRAY DRIED DETERGENTS (207)

This is another critical area of detergent manufacture. In this segment of processing, the neutralized sulfonates and/or sulfates are brought to the crutcher where they are blended with requisite builders and additives. From here the slurry is pumped to the top of a spray tower of about 4.5 - 6.1 m (15 - 20ft) in diameter by 45 - 61m (150 - 200 ft) high where nozzles, around the top, spray out detergent slurry of approximately 70 percent concentration.

A large volume of hot air enters the bottom of the tower rising to meet the falling detergent. For low density products, hot gas and powder flow concurrently downward.

This step is critical in that the detergent particles' shape, size and density are determined by all of the design preparation made previously, and the shape and size in turn will largely determine dusting and the solubility rate of the detergent itself in the washing process.

## 206 NEUTRALIZATION OF SULFURIC ACID ESTERS AND SULFONIC ACIDS

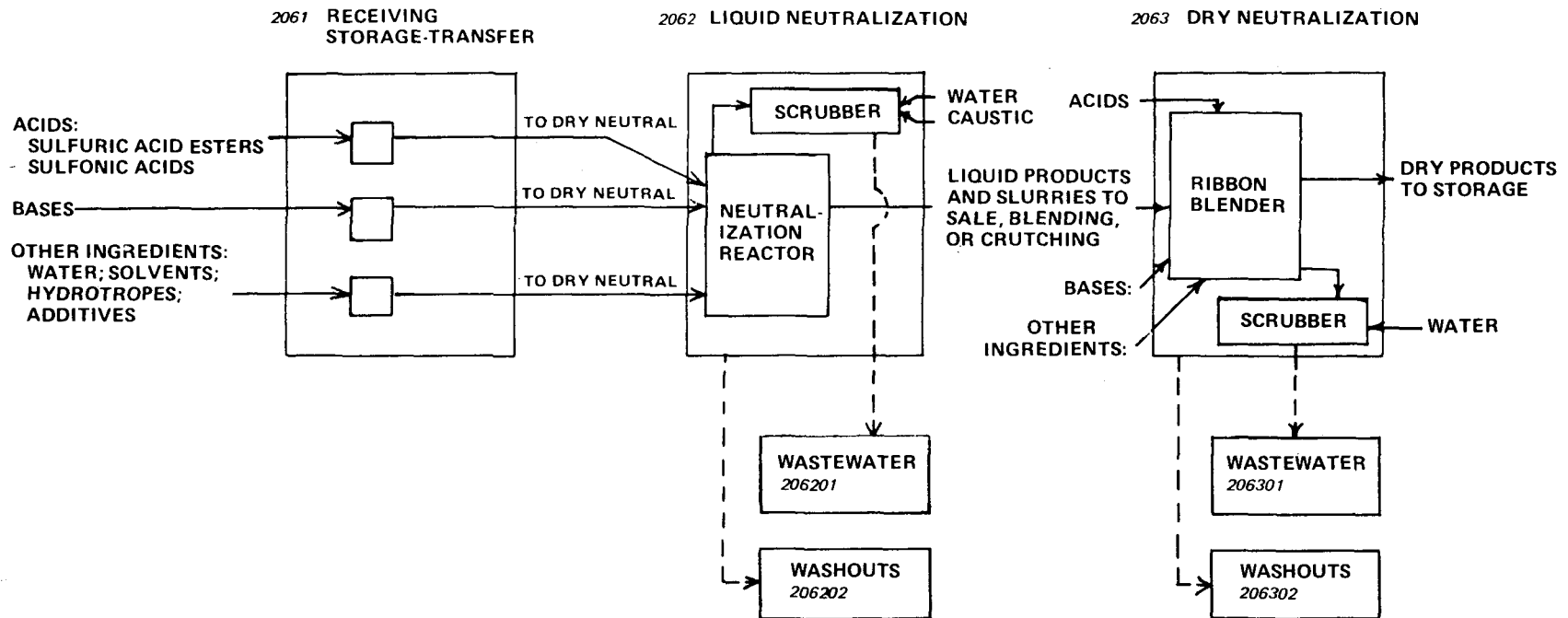

FIGURE 14

The air coming from the tower will be carrying dust particles which must be essentially eliminated to meet air quality standards.

Due to product change and buildup of combustible deposits, the spray towers are periodically shut down and cleaned. This practice varies from two or three times a week to once in two weeks or longer. One thing that all tower operations share is the cleaning process. First, the easily available material sticking to the tower walls is scraped to be recycled if at all possible, or sent to solid waste.

Men are sent into the tower with abrading equipment to continue the dry cleaning process. Here again, the product is usually preserved for reuse or disposed of as a solid waste.

Finally, the tower is thoroughly washed down by spraying streams all over the inside surface. The final step is mandatory since the detergent manufacturers must be very careful to avoid any mixing of any phosphate-nonphosphate formulations, white with colored systems or anionic with nonionic formulations.

The mixing problem is compounded somewhat by the fact that some detergent manufacturers custom process for a variety of marketers which requires more frequent spray tower "turnaround".

Waste water streams are rather numerous (see accompanying flow sheet for process). They include many washouts of equipment from the crutchers to the spray tower itself. One waste water flow which has high loadings is that of the air scrubber which cleans and cools the hot gases exiting from this tower. This is only one of the several units in series utilized to minimize the particulate matter being sent into the atmosphere.

All of the plants recycle some of the waste water generated. Some of the plants recycle all of the flows generated.

Due to increasingly stringent air quality requirements, we can expect that fewer plants will be able to maintain a complete recycle system of all water flows in the spray tower area. In the case of the fast "turnaround" tower, they, too, are unable to utilize all of their scrubber and other wash waters.

After the powder comes from the spray tower it is further blended and then packaged. Solid wastes from this area are usually recycled.

#### LIQUID DETERGENTS (208)

Sulfonated and sulfated products, as produced in processes described in 201 - 206 are pumped into mixing tanks where they are blended with numerous ingredients, ranging from perfumes to dyes. From here, the fully formulated liquid detergent is run down to the filling line.

### 207 SPRAY DRIED DETERGENTS

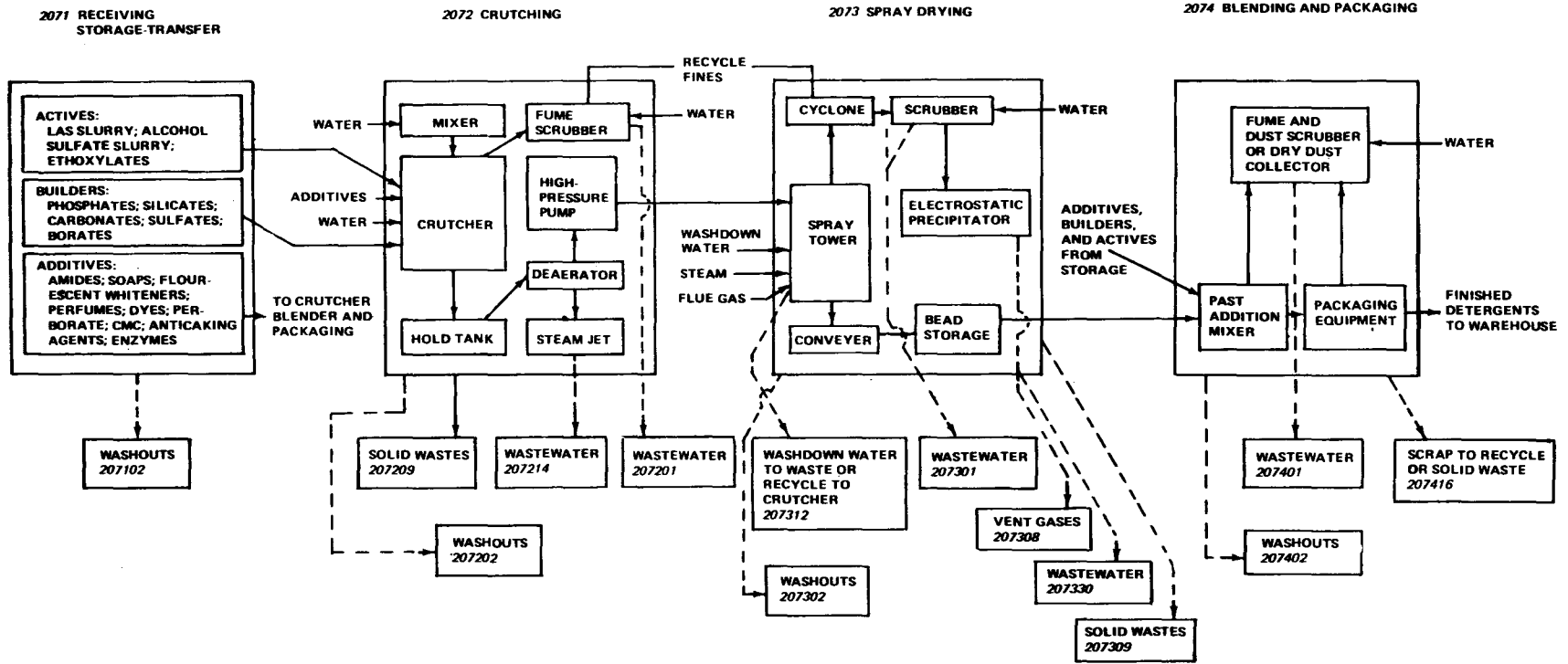

FIGURE 15

The filling line usually consists of a long conveyor which passes many stations. Each station performs a given task, such as filling, capping, checking weight, labeling, etc. Often, soap solutions are used to lubricate the conveyor so that the bottles flow smoothly past the various stations.

Whenever the filling line is to change to a different product, the filling system must be thoroughly cleaned out. This is equally true of the mixing equipment. Properties of differing products are often so contrasting that there must be no cross contamination; otherwise the performance and other specifications cannot be met. To avoid this problem the mixing equipment and all filling plumbing is thoroughly flushed with water until it runs clear.

#### DRY DETERGENT BLENDING (209)

Fully dried "active" (surfactant) materials are blended with additives, including builders, in dry mixers. In the more sophisticated plants mixing time is utilized to the maximum by metering components into weighing bins prior to loading into mixers. When properly mixed, the homogeneous dry product is packed for shipment.

Normal operation will see many succeeding batches of detergent mixed in the same equipment without anything but dry cleaning. This procedure is followed until the next formulation to be blended must not be contaminated with even an almost negligible amount of the previously prepared product. At this time the equipment must be completely washed down.

For this reason, a modest amount of waste water is required for the blender to maintain specification requirements.

The products fulfill a wide variety of industrial cleaning uses from dairy cleaning to box car washing. They are also used to some extent in household products.

#### DRUM DRIED DETERGENTS (210)

Drum drying of detergents is an old process. Much of the equipment still in use is well over thirty years old. The process yields a fairly friable product which can become quite dusty with any extensive handling.

There are several types of drum driers; those which have double rotating heated drums with liquid feed coming onto the space above and between the rolls, and a twin-drum dryer with dip or flash feed. The dip feed is a pan in which the "bottom" of the roll or drum picks up material to be dried.

The thin layer is removed continuously by a knife blade onto conveyors. The powder is substantially anhydrous. The vapors



## 208 LIQUID DETERGENT MANUFACTURE

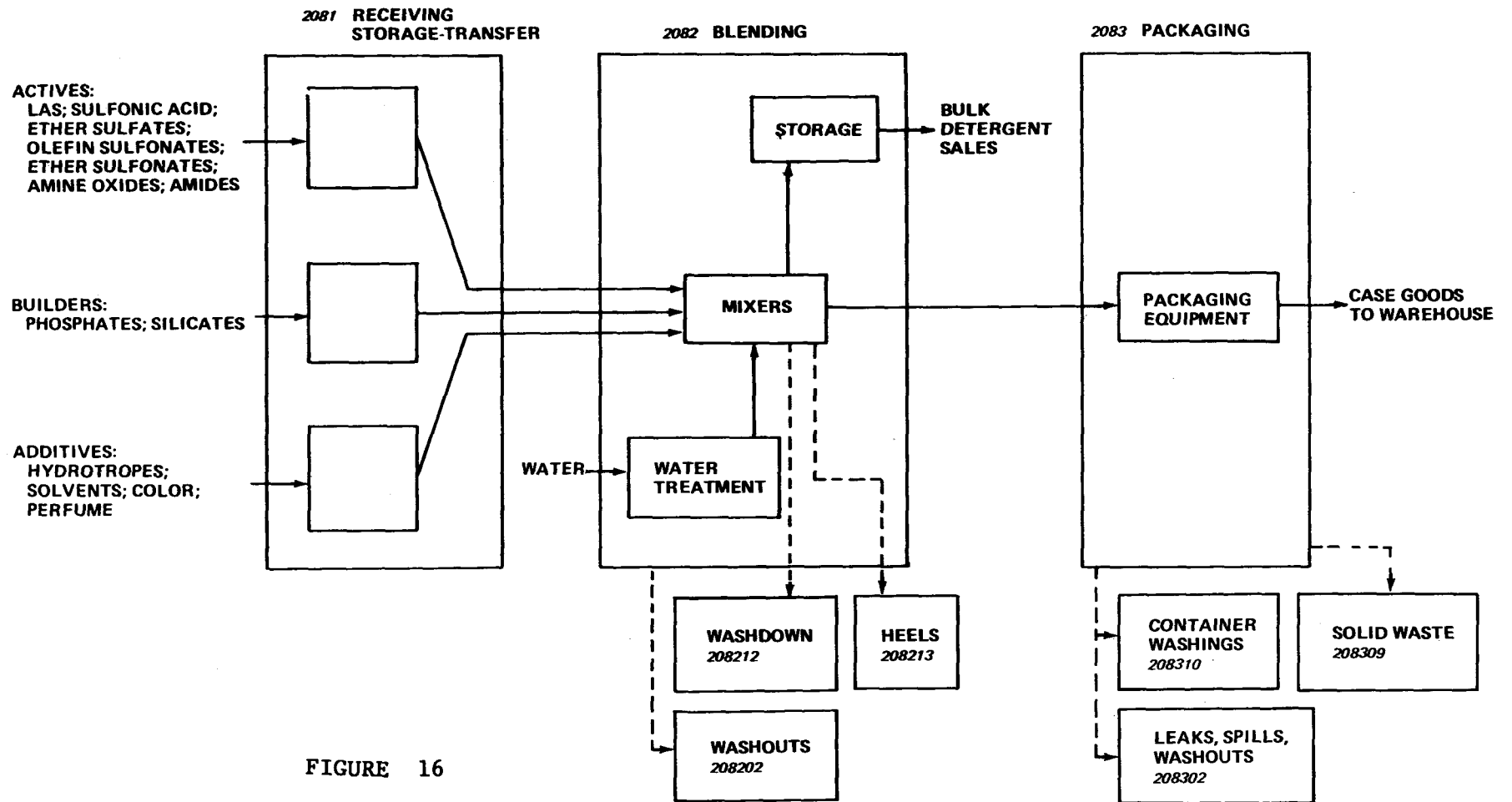

FIGURE 16

## 209 DETERGENT MANUFACTURE BY DRY BLENDING

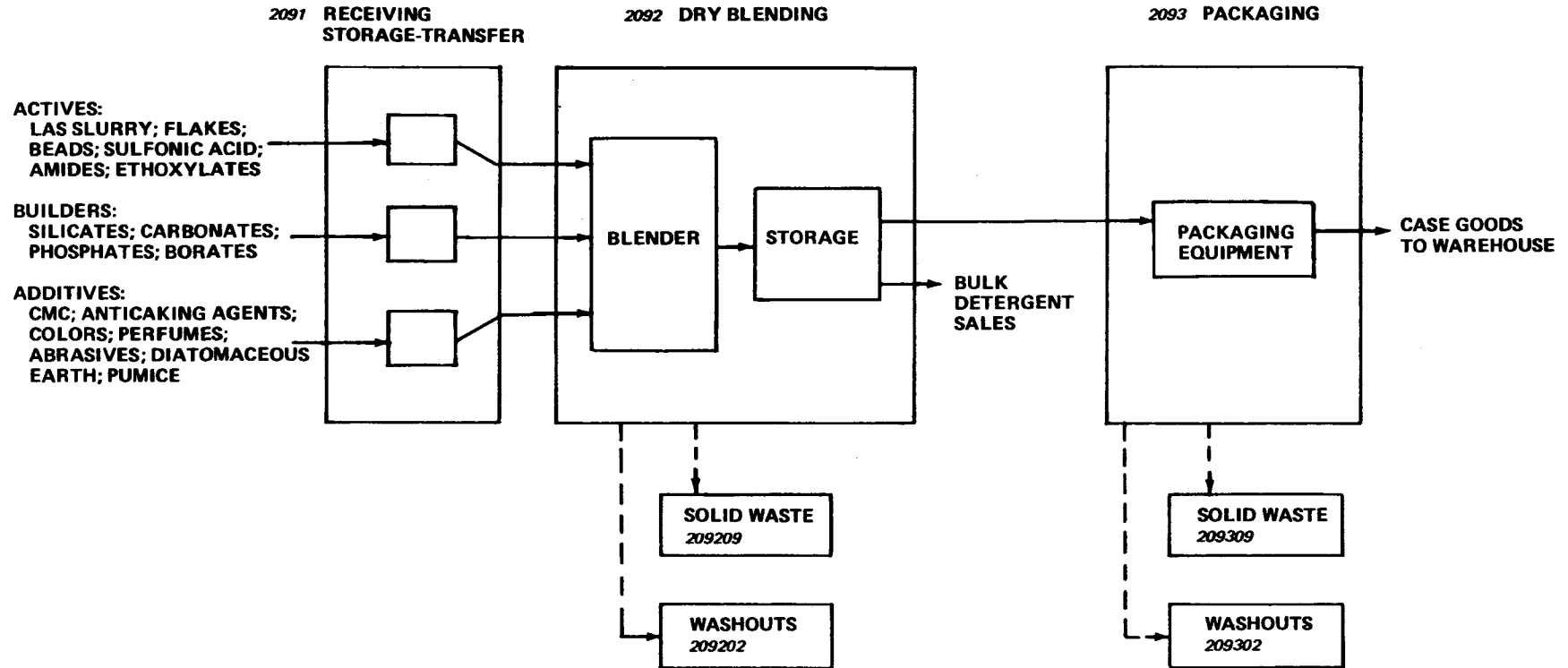

FIGURE 17

### 210 DRUM DRIED DETERGENT

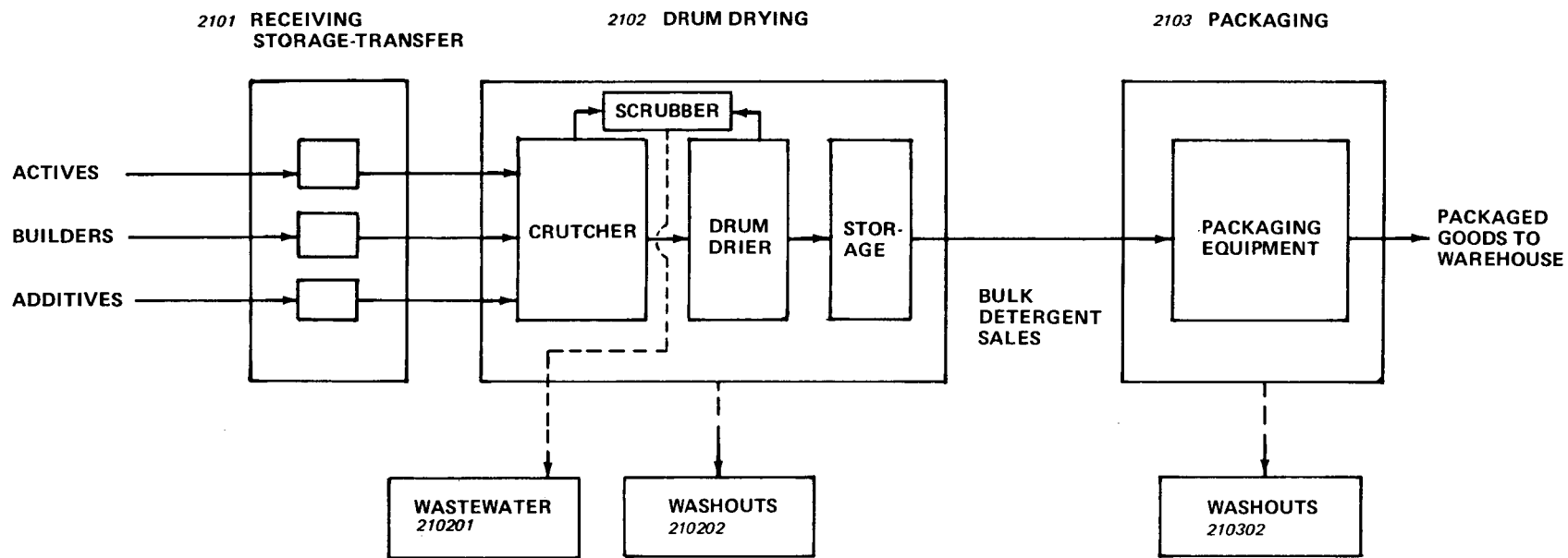

FIGURE 18

coming off are often collected and removed through a vapor head between the drums.

The rolls of a drum dryer are often 0.6 - 1.8 m (2 - 6 ft) in diameter and 0.9 - 4.5 m (3 - 15 ft) long with revolution speeds of 5 - 10 rpm. About 6 - 15 seconds residence time is provided the slurry on hot metal surface which is short enough to avoid degradation of heat-sensitive products.

As an example of the limitations of drying capacity, the capacity of the drum varies between 4.5 and 48.8 kg of finished product per sq meter of drying surface per hour (between 1 and 10 lb per sq ft per hour).

This operation should be essentially free of generation of waste water discharge other than an occasional washdown.

#### DETERGENT BARS AND CAKES (211)

In answer to the need for a "bar soap" which performs satisfactorily in hard water, the detergent industry manufactures and markets detergent bars. They constitute about 20 percent of the toilet bar market.

There are two types of "detergent" bars; those made of 100 percent synthetic surfactant and those blending synthetic surfactant with soap. Most products are of the latter type.

Once the active ingredients have been manufactured they are blended in essentially the same manner and in similar type of equipment used for conventional soap.

Due to the sensitive nature of the surfactant portion of the detergent bar, fairly frequent cleanups, including equipment washdowns, are required. Otherwise thermally degraded surfactant will contaminate the bar leading to such undesirable properties as stickiness and off-color.

#### FORMULATIONS

Soaps, detergents, and cleaning agents - some of the latter containing specific ingredients for specified cleaning purposes - contain a wide variety of chemical compounds to carry out the functions of the cleaning process involved. In the case of soap, the sodium or potassium salts of a range of fatty acids, having carbon numbers of 8 to 22, constitute the principal surfactant or cleansing agent. In addition, there is a certain amount of salt, NaCl, included in soap to perform the function of having an electrolyte present, which increases diffusion and surface orientation, by ion reactions. Glycerine, itself, is often left in the soap, or purposely added, for its general effect in promoting a feeling of softness and slipperiness, the latter

## 211 DETERGENT BARS AND CAKES

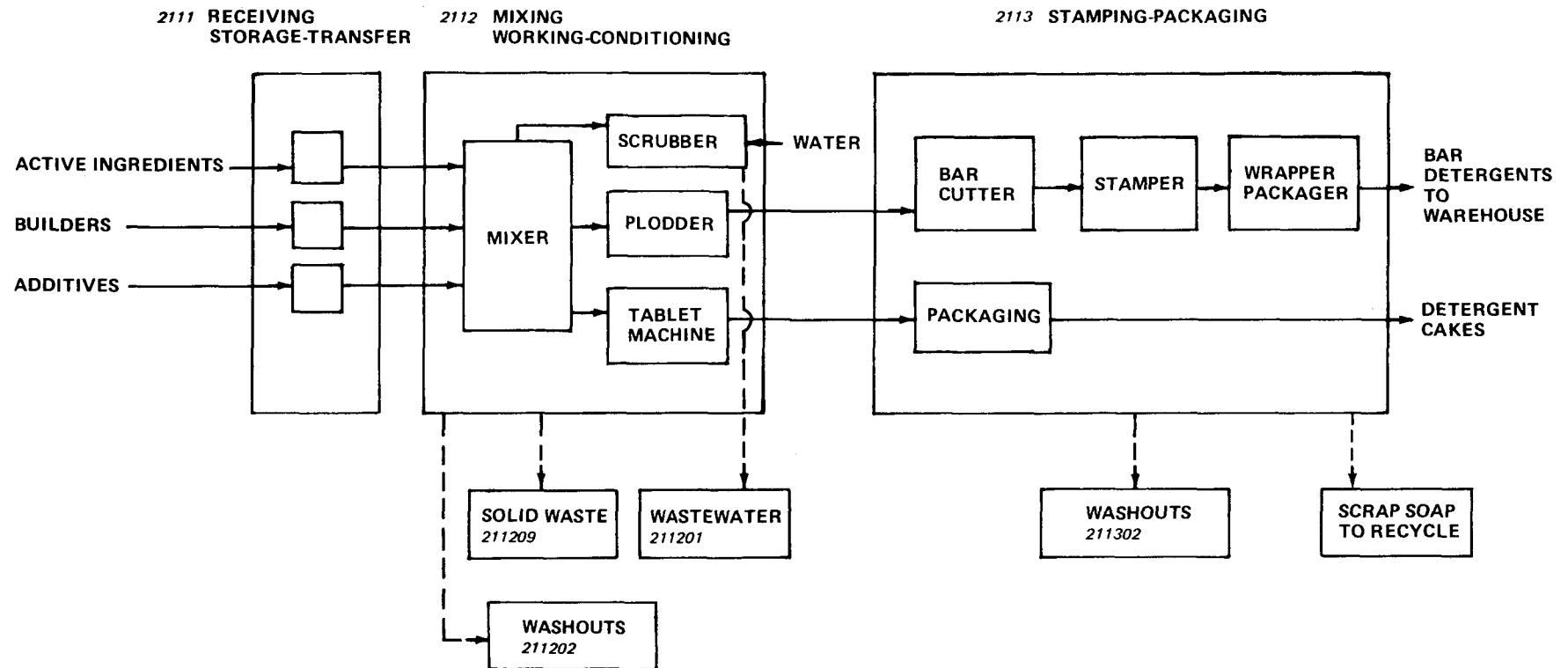

FIGURE 19

feature being one that leads the user to thoroughly wash off soap residue, especially in personal use.

In the case of a typical all-purpose household detergent, a general average of approximately ten chemical components are included in a typical formulation. All these compounds have definite functions to produce a balanced detergent. The principal component, of course, is the surfactant itself, typically an alkyl-aryl sulfonate, a sulfate salt of lauryl alcohol, and various types of sulfates or sulfonates derived from ethoxylated alcohol or of other aromatic compound sulfonates. The surfactant itself is largely effective in reducing interfacial tension between the surface to be cleansed and the soil deposit itself. Typically, detergents contain approximately 5 - 30 percent of such surfactant active-ingredient material.

An important ingredient in detergents, at least up to the present, is the radical phosphate,  $PO_4$ , which is included in a variety of forms, discussed later. The function of the phosphate is that of a disperser, a suspender, an emulsifier, and a buffer to reduce the general alkalinity of the surfactants and produce a detergent in the pH range of 7.0 - 9.0. The phosphate ion has been an important multiple functioning ingredient in detergents. If it is reduced by laws, these functions of a detergent will have to be handled by other compounds that then need to be included in a formulation. Another major constituent of most detergents is an inorganic salt. Most typically, these are either in the form of sodium sulfate and, occasionally, sodium chloride or other added inorganic salts. In detergents they serve the purpose of diminishing the interfacial tension, particularly that between water, carrying the detergent, and the soil deposition to be removed. They also act for this reason as a disperser of the soiling. Additionally, an important function is to provide an electrolyte; i.e., an ion content which enhances and accelerates the interchange and surface orientation of wetting and organic solubilizing portions of a molecule. These inorganics are usually present up to about 20 percent in the typical formulated detergent.

Methyl cellulose, in amounts of about 1 percent, are present in many detergent formulations to reduce redeposition of the soiling, once it has been removed from the soiled surface. Silica, in various forms, but usually in the form of sodium silicate, to an extent of 5 percent or less, is included in many formulations to minimize the corrosion of metals, particularly those present in a drum liner or other washing container surfaces. Fatty acids, such as are used in the soap manufacturing process by neutralization, are added up to a range of about 3 percent, largely to enhance foam stability and, therefore, to prevent an over-use of the detergent in the washing solution. The borates are also generally added, often in the form of sodium perborate. These borate compounds are added up to an extent of 10 percent, and serve the purpose of bleaching a fabric and/or removing stain deposits of soiling on textile

surfaces. In addition to these components there are often perfumes added, as well as anti-oxidants. Dyes are often added as brighteners, even fluorescent dyes, so that the reflectivity of the surface is enhanced, making it look brighter. Obviously, the perfumes are to give a more pleasing odor and aroma. The anti-oxidants are added, particularly when there are fatty acids in the composition, to avoid a noticeably rancid odor.

In general, cleaning compounds contain far more of the inorganic salt compounds, which are more efficacious in cleaning duties against surfaces such as dishware, flooring, and in the cleaning of machine parts, after oil has been used during lathing operations. Thus, a typical floor cleaning formulation contains as much as 60 percent of sodium silicate, as much as 10 percent of phosphates, in the form of tri-polyphosphate, also, occasionally the tetravalent potassium pyro-phosphate. The surfactant in such cases is usually an alkyl-aryl sulfonate to make up the balance of the composition. Hand dishwashing detergents contain active ingredients such as amine oxides and sulfated ethoxylated lauryl alcohols. The industrial machine dishwasher products are compounded as high as 50 percent by weight sodium tri-polyphosphate, another 25 - 50 percent sodium metasilicate (anhydrous) and a minor amount 2 - 5 percent organic surfactant.

Sodium carbonate, present either as the normal divalent carbonate, or as the sesqui-carbonate, in amounts ranging up to 10 percent, is commonly used. Again, a tri-polyphosphate is included to the extent of 40 percent or up to the balance of the detergent, if it is a powder.

Of all the functions, mentioned earlier with respect to the compound, illustrating the functions, the main purpose of a soap, detergent or cleaning agent must be to loosen occluded soils and to suspend it so that it does not redeposit. Accordingly, the basic principle of the surfactant, even as soap itself, is the lowering of the interfacial tension between the systems consisting of the fabric or surface to be cleaned and the soiling on that surface. Frequently the surfactant function is accomplished by components which also reduce the interfacial tension between the water in the system, and the air. This leads to high foaming compositions which are not useful in actually cleaning and removing the soiling depositions.

In the case of soap, now used mostly for personal body care, the main function is that of interfacial separation, from the epithelial or skin surface and the soiling, which can be produced by the body itself, as well as from extraneous particulate matter, oils and greases. The main components of the body's own soiling are those of the fatty acid-esters which range in composition from carbon numbers C5 up to C37. The compounds of lower molecular weight are generally the fatty acid salts themselves or the fatty acid esters of these salts. The other

main soil components are the usual sebaceous gland exudate, consisting largely of the esters of glycerine.

These glyceryl esters are not unlike those found in fats itself; however, they range in chemical structure and composition to a far greater extent than in the soap fatty acids. Another component of sebaceous soiling is the androstanyl-sterols and squalenes. These have molecular weights as high as C37 and range down to those in the order of C19. These esters are particularly difficult to remove, as the sebum is itself a very complex physical-chemical inter-diffused solid and semi-solid solution.

Surface tension reducing agents, such as inorganic salts, are not very useful in the cleansing problem requiring the use of a soap. Again, they serve mostly the function of decreasing interfacial tension between air and water, and roughly for each per cent of content in the cleansing solution they reduce the surface tension by approximately 2 dynes per centimeter. Their equivalency can be obtained readily, without the foaming disadvantage, simply by raising the temperature of cleaning about 10 C (50 F) which gives the equivalent net effect.

As mentioned, there are a variety of inorganic salt compounds which are found in detergents and serve to perform the functions first illustrated. While normally, in soap, sodium chloride is the usual electrolyte, the compounded detergents have a far broader range of inorganic compounds to serve functions illustrated earlier. In addition to the usual salts of sulfuric acid, usually present as the sodium sulfate, there are a variety of carbonates, silicates, phosphates and borates.





## SECTION IV

### INDUSTRY CATEGORIZATION

#### Introduction

There are several ways in which the soap and detergent industry could be categorized. While each may have its own special rationale, the search was for the system of categorization that would best identify potential waste water sources and controls, provide a permit granting authority with a way to analyze a specific plant regardless of its complexity, and permit monitoring for compliance without undue complication or expense. The systems examined included categorization by raw materials used, wastes discharged, finished products manufactured, processes employed, and plant size or age.

Systems based solely on raw materials used, wastes discharged, or finished products manufactured are either overly complex, even if based on generic chemical groups, or highly arbitrary if greatly simplified. This is true in respect to both categorization and monitoring for compliance. Furthermore, they take into consideration only the potentials for waste generation that are inherent in the nature of the materials (e.g., boiling point, solubility, etc.) and ignore the potentials of other factors such as processes employed.

The operations of the soap and detergent industry may be considered to consist of application of processes to raw materials for production of intermediates, which in turn are subjected to further processing to arrive at the finished or marketed products. There is an intimate relationship within chains of raw materials, intermediates, processes and finished products with the processes employed being the key to obtaining the finished products from the raw materials. Thus, a system of categorization based on processes reflects all variables that affect raw waste discharges.

Plants employing specific sets of processes tend to be of the same general age and the principal effect of age is reflected in the processes utilized (e.g., kettle boiling of fats versus continuous neutralization of fatty acids for production of neat soap), not in the level of raw waste load generated by a particular set of processes. Moreover, the determination of age is complicated by extensive repair and replacement of process units. For example, what is the age of a large kettle boiling facility originally constructed 50 years ago, but in which an average of one kettle has been reconstructed every two years for the past thirty years? What is the age of a spray drying tower constructed in 1930 for manufacturing soap granules, modified in 1946 for production of spray dried detergents, and subjected to periodic replacement of working parts since modification? In view of the foregoing, age of plants is not considered to be a practical basis for categorization.

Plant size as a basis for categorization is even more complex than evaluation of age. Some independents have relatively small plants that in complexity of processes employed equal the largest plants of the major international companies. A relatively small operation consisting of a single process chain (e.g., production of bar soaps utilizing fatty acid neutralization) may equal in size the comparable segment of the largest complex plant. Size of plant may be the result of difference in the physical size of individual units of equipment or the number of units of the same physical size. Thus, categorization based on size would result in an unmanageable welter of categories, with many representing only one or a very few plants.

Though plant size cannot be used as a basis for orderly categorization, and thus is not reflected in the proposed guidelines and standards, there are factors generally associated with size that should be considered. The complexity of a plant (i.e., number of processes and products) is frequently associated with size, the small plants tending to be more limited in diversity. This may curtail the ability of a small plant to work off a by-product or waste as a feed material for other processes. Similarly, the limited volume of a waste produced in a small plant may prohibit installation of by-product utilization processes (e.g., use of nigre from kettle boiling for manufacture of pet soaps and soap-based lubricants) on a scale that is economically viable.

#### Categorization

The categorization consists of two major categories and 19 subcategories. The major categories follow the natural division of soap manufacturing (production of alkaline metal salts of fatty acids derived from natural fats and oils) and detergent manufacturing (production of sulfated and sulfonated cleaning agents from manufactured raw materials, primarily petroleum derivatives). The subcategories are based on discrete manufacturing units employed by the industry for conversion of raw materials to intermediated products and conversion of intermediate products to finished/marketed products. A manufacturing unit may contain a single process (e.g., continuous neutralization for production of neat soap by fatty acid neutralization) or a number of processes (e.g., crutching, drying, milling, plodding, stamping and packaging for production of bar soaps from neat soap).

Several advantages result from the categorization. It accounts for the variable effects on raw waste loads attributable to raw materials, processes and finished product. The potential sources and natures of waste waters are readily discernible, as are the potential in-plant control measures. It is amenable to use in development of permits irrespective of the complexity of a plant.

The subcategories are as follows:

## SOAP MANUFACTURE

Soap Manufacture by Batch Kettle (101)\*  
Fatty Acid Manufacture by Fat Splitting (102)  
Soap Manufacture by Fatty Acid Neutralization (103)  
Glycerine Concentration (104A)  
Glycerine Distillation (104B)  
Soap Flakes and Powders (105)  
Bar Soaps (106)  
Liquid Soap (107)

## DETERGENT MANUFACTURE

Oleum Sulfonation and Sulfation (Batch and Continuous) (201)  
Air-SO<sub>3</sub> Sulfonation and Sulfonation (Batch and Continuous) (202)  
SO<sub>3</sub> Solvent and Vacuum Sulfonation (203)  
Sulfamic Acid Sulfation (204)  
Chlorosulfonic Acid Sulfation (205)  
Neutralization of Sulfuric Acid Esters and Sulfonic Acids (206)  
Spray Dried Detergent (207)  
Liquid Detergent Manufacture (208)  
Detergent Manufacturing by Dry Blending (209)  
Drum Dried Detergents (210)  
Detergent Bars and Cakes (211)

\*The numbers shown after the subcategories are used throughout the report to identify the subcategories/processes.

Three of the subcategories have been further segmented in recognition of the added waste generation that may result from specific types of operations. A separate segment has been established under fatty acid manufacture for the hydrogenation of the fatty acids to accommodate those facilities employing hydrogenation. Under spray dried detergents three segments have been designated; normal operation, air quality restricted operation and fast turnaround operation. The latter two produce much more waste water than the former and thus cannot effect the same degree of recycle of waste water to process. A separate segment has been established within the liquid detergent subcategory for fast turnaround operation involving automated fill lines, a phenomenon closely associated with the small producer of liquid household detergents.



## SECTION V

### WASTE CHARACTERIZATION

#### INTRODUCTION

Numerous organic and inorganic chemical compounds are used in the manufacture of soaps and detergents. As the reactions are carried out some of these materials and their derivatives enter the waste waters from the processing steps. These materials are then treated as contaminants and processed as waste water in conventional waste treatment units. In discussion of the individual unit processes that follow, the sources and nature of waste waters are presented in some detail. The numbers associated with the processes and waste streams are keyed to the process flow sheets, Figures 1 through 19.

#### SOAP MANUFACTURE BY BATCH KETTLE -- (PROCESS 101)

##### Introduction

Effluents of this process arise from three sources. Handling of fats and oils results in leaks and spills (streams 101102 and 101202). These are usually collected with water and the fats skimmed. Pretreatment of the fats or oils results in process waste waters 101321 and 101218. Soap making results in two by-products, 101319 and 101320, which generally are disposed of as waste waters. These streams are discussed in detail in the following sections.

##### Water and Waste Water Balance

Water for this process will usually come from municipal systems since the plants are old and somewhat isolated. For the barometric condenser (101218) surface water or cooling tower water will be used. Since steam is used for heating the fat in both pretreatment and saponification, some process water is introduced in this manner.

Kettle boiling soap is a batch process and water use will be intermittent. Instantaneous flows of 0.12-18.9 l/sec (2-300gpm) will be experienced. Overall water use can be limited to 623 l/kg (75 gal/1000 lb) of soap, but as much as 2080 l/kg (250 gal/1000 lb) is used.

Water reuse and recycle is not common in kettle boil soap plants for process water. Where a barometric condenser is used for the steaming pretreatment step, recycle through a cooling tower is sometimes used, but even here use of surface water is more common. Except for the barometric condenser, all water use can be considered process water.

With reasonable water conservation, and excluding barometric condenser water, total waste water discharge should not exceed 2080-2500 l/kg (250-300 gal/1000 lb) for all steps included within the subcategory. Inclusion of barometric condensers with recycle through cooling towers and limited blowdown would approximately double the volume of discharge.

Specific waste water sources and constituents are discussed generally and specifically tabulated in the next section.

### Waste Water Constituents

Leaks, spills and storm runoff or floor washing (streams 101102 and 101202) are invariably collected for recovery of fats and oils by settling and skimming in fat traps. The waste water will contain some emulsified fats, since the skimmers and settlers do not operate at 100 percent efficiency.

The fat pretreatment is carried out to remove impurities which would cause color and odor in the finished soap. Acid and/or caustic washing may be used. This results in sodium soaps or sulfuric acid solutions of fatty acids (101231). Other pretreatment steps make use of proprietary chemical formulas which result in water containing the treatment chemicals, fatty impurities and emulsified fats. Clay and carbon treatments give solid wastes and do not directly result in aqueous effluents, but steam is used for heating and the condensate must be removed. Often a barometric condenser is used, and there is carryover of low molecular weight fatty acids (101218).

Waste waters from the fat skimmer and from the pretreatment steps each contribute about 1.5 kg of BOD<sub>5</sub> per 1000 kg of soap (1.5 lb/1000 lb). Concentrations typically are 3600 mg/l BOD<sub>5</sub>, 4267 mg/l COD, 250 mg/l of oil and grease with a pH of 5.

Saponification of the fats and oils by sodium hydroxide and salting out of the soaps (graining) with salt does not necessarily lead to any effluent. The nigre which comes from washing excess salt and impurities from the neat soap with aqueous caustic is always recycled to some extent. The organic portion consists of low grade soap. In some plants, the nigre is acidified to convert the soaps to fatty acids which are recovered for sale. Although acidification removes much of the organic contaminant, some is still discharged (101320). Some manufacturers' third alternative for the nigre is the sewer (101319).

The stream referred to as sewer lyes (101319) arises most often from the reclaiming of scrap soap. The lye and salt water added to separate the soap must be discarded because it contains paper and other dirt.

Sewer lyes and nigre are concentrated waste waters (in mg/l) alkalinity up to 32,000, BOD<sub>5</sub> as high as 45,000, COD up to

64,000, chlorides of 47,000 and a pH of 13.5. Volumes, however, are small - 249 l/kg of soap (30 gal./1000 lb).

## FATTY ACIDS BY FAT SPLITTING -- (PROCESS 102)

### Introduction

In this process, fats and oils are converted to fatty acids and glycerine by hydrolysis with water. In Section 103 conversion of fatty acids to soap is considered and Section 104 deals with glycerine recovery. There are two process condensates which contain organic contaminants - (102322 and 102418). Also, treatment of the fatty acid still bottoms results in contaminated water (102423). Since streams from fat pretreatment (102221) and leaks and spills are essentially the same as analogous streams (101102 and 101202) in Process 101, the discussion will not be repeated.

Fatty acids from the fat splitting frequently are given a light hydrogenation (usually employing a nickel catalyst) to eliminate polyunsaturation in the acids. The only waste water coming from this step is that arising from equipment cleanouts.

### Water and Waste Water Balance

In general fatty acid plants are relatively new and contain a water recycle system. The small amount of clean water required will come from surface water, municipal systems, or wells. Although operation of surface condensers and barometric condensers requires thousands of gallons per minute, blowdown from fatty acid plants ranges from 3.2-12.6 l/sec (50-200gpm).

The other main contaminated stream is from treating still bottoms (102423). It is smaller, but highly contaminated.

Cleanouts of hydrogenation equipment are infrequent and the total volume of water is small. Potable water is used to preserve cleanliness.

With adequate water conservation, including recycle of barometric condenser water, total discharge should not exceed 600-700 gal/1000 lb of anhydrous product in contrast to the present range of 400-23,000 gal/1000 lb.

### Waste Water Constituents

See Process Section 101 for discussion of 102102, 102202, and 102402 which are waste waters from leaks, spills and storm runoff. Also, fat pretreatment wastes 102205 and 102224 are covered under Process 101 for the analogous streams.



Process condensate 102322 from fat splitting will be contaminated with volatile low molecular weight fatty acids as well as entrained fatty acids and glycerine streams. The barometric condensate 102418 will also contain volatile fatty acids. These streams will be settled and skimmed to remove the insoluble fatty acids which are processed for sale. The water will typically circulate through a cooling tower and be reused. To keep emulsified and soluble fatty material at a reasonable level, part of the stream is purged to the sewer. This blowdown (102204, 102304, 102404) contributes about 10 kg of BOD<sub>5</sub> and 18 kg of COD per kkg (10 lb BOD<sub>5</sub> and 18 lb COD/1000 lb) of fatty acids produced plus some oil and grease.

Treatment of stream 102423 consists of acidification to break the emulsion and skimming of insoluble fatty acid pitch. The waste water is neutralized and sent to the sewer. This waste water will contain salt from the neutralization, zinc and alkaline earth metal salts from the fat splitting catalyst and emulsified fatty acids and fatty acid polymers. One plant had about 0.6 kg of BOD<sub>5</sub> and 0.9 kg of COD/kkg (0.6 lb BOD<sub>5</sub> and 0.9 lb COD/1000 lb) of fatty acids from this source.

Fatty acids and a modest amount of nickel soaps constitute the bulk of contaminants from hydrogenation. Very small amounts of suspended nickel may be present.

#### SOAP BY FATTY ACID NEUTRALIZATION -- (PROCESS 103)

##### Introduction

This process is relatively simple and high purity raw materials are converted to soap with essentially no by-products. Leaks, spills, storm runoff and washouts are absent. There is only one waste water of consequence. It is 103326, the sewer lyes from reclaiming of scrap. Stream 103224 is generally nonexistent since there is a net consumption of brine in the process.

##### Water and Waste Water Balance

Except for the small amount of water (258 l/kkg; 31 gal/1000 lb of soap) used for reclaiming scrap and resulting in the sewer lyes, the process produces no other aqueous effluent. Potable water is fed into the process.

##### Waste Water Constituents

The sewer lyes (103326) will contain the excess caustic soda and the salt added to grain out the soap. Also, they will contain some dirt and paper not removed by the strainer. Typically 3 kg of BOD<sub>5</sub> and 5.5 kg of COD/1000 kg (3 lb of BOD<sub>5</sub> and 5.5 lb of COD/1000 lb) of soap will be discharged.

#### GLYCERINE RECOVERY -- (PROCESS 104)

## Introduction

The feedstock for this unit process comes from soap boiling and fat splitting processes 101 and 102. Both crude glycerines will contain about 90 percent water, but that from soap kettle boiling will contain a fair amount of salt and some NaOH. Both streams will contain soap or fatty acids which must be removed in the pretreatment section by precipitation with alum and filtration.

There are three waste waters of consequence from this process; two barometric condensates, from evaporation of water (104318) and from distillation of glycerine (104418), plus the glycerine foots or still bottoms (104428). Contaminant of the barometric condensates is essentially glycerine with a little entrained salt. The glycerine foots are water soluble and are removed by dissolving in water.

Glycerine can also be purified by use of ion exchange resins to remove the sodium chloride followed by evaporation of the water. This process puts additional salts into the waste water but results in less organic contamination.

## Water and Waste Water Balance

Compared with the amount of water used in the barometric condensers, water used for other purposes is negligible.

Installations not recirculating cooling water through a cooling tower use from 698,000-1,540,000 l of water per kkg (84,000-185,000 gal. of water per 1000 lb) of glycerine produced. With a cooling tower, blowdown consumes 9975 l/kg (1200 gal./1000 lb) glycerine.

The ion exchange process is reported to use 449 l/kg (54 gal/1000 lb) of glycerine for both backwashing and regeneration.

The source of water for glycerine recovery is usually surface water. Since it is used mainly for condensing steam, quality is unimportant. Typically, a plant will withdraw water from a river, put it through the barometric condensers, and discharge it into the river with no treatment.

As mentioned above, water used for washout of the still, for steam generation and the ion exchange process is relatively small, generally less than 200 gal/1000 lb. These water uses require treated water, usually from municipal supplies. No water is produced or consumed in the process. Approximately 60-70 percent of the total water used is associated with the glycerine concentration operation.

## Waste Water Constituents

The two barometric condensers streams (104318 and 104418) become contaminated with glycerine and salt due to entrainment. Stream

104428 is a water soluble by-product which is disposed of by washing into the sewer. It contains glycerine, glycerine polymers, and salt. The organics will contribute to BOD<sub>5</sub>, COD and dissolved solids. The sodium chloride will also contribute to dissolved solids. Little or no suspended solids, oil and grease or pH effect should be seen.

From the glycerine evaporator barometric condenser about 30 kg of COD and 15 kg of BOD<sub>5</sub> per kkg (30 lb of COD and 15 lb of BOD<sub>5</sub> per 1000 lb) of product will be discharged. The foots and glycerine still contribute about equal amounts of BOD<sub>5</sub> and COD, 2.5 kg (2.5 lb) and 5 kg (5 lb) respectively per kkg (1000 lb) of glycerine produced. Because the barometric condensers use large amounts of water, concentrations are low. The foots are diluted only enough to remove them from the still, and concentrations of organics and salts are about 30,000-400,000 mg/l.

#### SOAP FLAKES AND POWDERS -- (PROCESS 105)

##### Introduction

In this process the neat soaps from processes 101 or 103 are converted to flakes or powders for packaging and sale. The unit processes produce the dry soap in the physical form desired. There are a number of possible effluents shown on the flow sheet for process 105. However, survey of the industry showed that most operating plants either recycled any waste water to extinction, or used dry cleanup processes. Occasionally water will be used for equipment cleanup.

In converting neat soap to flakes, powder or bars, some scrap results. The flow sheets show scrap reclaim in processes 101 and 103. There is an aqueous effluent - sewer lyes - from this reclaim operation (streams 101319 and 103326). All existing soap plants both make and process soap. Therefore, the given categorization will handle the effluent sewer lyes under process 101 or 103. Should a plant start with neat soap, the sewer lye guidelines should be applied to 105.

#### BAR SOAPS -- (PROCESS 106)

##### Introduction

To produce soap bars, neat soap is dried and physically worked prior to extrusion and stamping. Some plants have filter backwash (106129), scrubber waters or condensate from a vacuum drier (106201) and water from equipment washdown (106202 and 106302).

##### Waste Water Balance

Water from drying neat soap is vented to the atmosphere. Water use by plants producing dry soap varies from none to 6230 l/kg (750 gal/1000 lb) of soap made. The largest quantity is required when a barometric condenser is used on the drier. In those operations employing barometric condensers, both volume of discharge and level of contamination can be reduced materially by installation of an atmospheric flash evaporator ahead of the vacuum drier.

#### Waste Water Constituents

The contaminant of all waste waters is soap which will contribute primarily to BOD<sub>5</sub> and COD. Concentrations of BOD<sub>5</sub> and COD are typically 1600 mg/l and 2850 mg/l respectively in the scrubber (106201), which is the major source of contamination. Driers contribute from 0.3 - 0.7 kg/kg (0.3 - 0.7 lb/1000 lb) of soap to waste waters. Washouts of the filter and of equipment account for the remainder to give an average process total of 2 kg of BOD<sub>5</sub> per kg (2 lb/1000 lb) of dry soap.

#### LIQUID SOAPS -- (PROCESS 107)

##### Introduction

Production of liquid soaps consists of a simple blending operation followed by filling of rather large containers (drums) for sale. According to manufacturers interviewed, there is very little aqueous effluent. Leaks and spills can be recycled or handled dry. Washout between batches is usually unnecessary or can be recycled to extinction.

##### Water Balance

Some water is used as a part of the liquid soap formula, and small amounts (16.6 l/kg of dry soap or 2 gal /1000 lb) are occasionally used for cleanup.

##### Waste Water Constituents

The liquid soaps will contribute to BOD<sub>5</sub>, COD, and dissolved solids. However, amounts are very small (0.1 kg BOD<sub>5</sub> and 0.3 kg COD/kg of product) (0.1 lb BOD<sub>5</sub> and 0.3 lb COD /1000 lb).

#### OLEUM SULFONATION AND SULFATION -- (PROCESS 201)

##### Introduction

The principle raw materials for synthetic detergent manufacture are alkylbenzenes, fatty alcohols and alcohol ethoxylates. These are converted to surface active agents by sulfonation or sulfation and neutralization with sodium hydroxide or other bases. There are no process waste waters from the oleum

sulfonation and sulfation reaction, leaks, spills and washouts result in some highly acidic wastes (streams 201102, 201202 and 201302). The oleum tank breathing scrubber which collects SO<sub>3</sub> vapors during filling of the tank also contributes sulfuric acid to the waste waters (201101). Although cooling water is used for the sulfonation, it is indirectly used to cool Freon or brine systems and doesn't become contaminated.

Although the amount of acids released are small, both the sulfuric and sulfonic acids are strong acids and small amounts can give a pH of 1 - 2; therefore, neutralization of spills is imperative. Also, the sulfonic and sulfuric acid esters are surface active (MBAS) and contribute to BOD<sub>5</sub> and COD. Some oil and grease can be expected from spills of organic raw materials. The pH will be very low.

#### Water and Waste Water Balance

Usually leaks from pump packing glands will be flushed away continuously with small streams of water. Little water is used. Because the water use is small, 100 - 2740 l/kg (12-330 gal/1000 lb) of surfactant, potable water is generally used. Since the oleum tank scrubber will only be used when the tank is being filled, little water is used here.

Since sulfonation is highly exothermic and temperatures must be kept low to avoid charring, the cooling water for sulfonation is a large stream. Well water or municipal water is preferred because of their low temperatures making the refrigeration cycle more economical. In the more efficient operations the cooling water is recycled through a cooling tower and the discharge is limited to blowdown.

#### Waste Water Constituents

Since the source of contaminants is leaks and spills, all the raw materials and products may be present. These are fatty alcohols, dodecylbenzene, sulfuric acid, dodecylbenzene sulfonic acid, and the esters of sulfuric acid and alcohols. These chemicals will contribute acidity, sulfate ion, MBAS, oil, BOD<sub>5</sub> and COD to the waste water stream.

Concentrations of contaminants will depend on the amount of water used for washdown. Amounts of contaminants average 0.2kg (0.2 lb) BOD<sub>5</sub>, 0.6 kg (0.6 lb) COD and 0.3 kg (0.3 lb) MBAS per 1000 kg (1000 lb) of sulfonated product. The pH will usually be very low (1-2) unless the sulfonation wastes are commingled with neutralization wastes.

### AIR-SO<sub>3</sub> SULFONATION & SULFATION (PROCESS 202)

#### Introduction

Anhydrous  $\text{SO}_3$  is used to sulfonate alkylbenzenes and to sulfate alcohols and alcohol ethoxylates converting them to surface active agents. The acids produced are neutralized with NaOH, ammonia and other bases as described in process 206.

Because of the hazardous nature of anhydrous  $\text{SO}_3$ , the systems designed for its use are essentially leak-free. However, any leaks and spills will end up in the waste waters. The main source of contaminated waste waters are by-products. The incoming air- $\text{SO}_3$  stream will be scrubbed with  $\text{H}_2\text{SO}_4$  and the spent acid purged (202309). The effluent gas contains entrained sulfonic acid, sulfuric acid and  $\text{SO}_2$  (202301).

Another sizable source (202302) of contamination comes from startup and shutdown. Plants that run 7 days per week, 24 hours per day will obviously have much less contamination from this source than plants that shut down more frequently.

### Water Balance

A considerable amount of water is used for cooling the sulfonation reactor. This is usually a clean water stream. Approximately 249 l/kg (30 gal/1000 lb) of water is used for disposing of by-products in continuous processes. Water use in batch operations will be several times as great for washing reactors and filters. All of this water usually goes to the sewer.

### Waste Water Constituents

Stream 202303 which receives startup slop will contain unreacted alcohols, alcohol ethoxylates, and alkylbenzenes. These will show up as oil and grease as well as  $\text{BOD}_5$  and COD. The other contaminated streams (202102, 202202, 202309 and 202301) as well as 202303 will contain sulfonic and sulfuric acids. These materials affect MBAS, acidity,  $\text{SO}_4$ , dissolved solids,  $\text{BOD}_5$  and COD.

Concentrations from the process were observed to range from 380-520 mg/l of  $\text{BOD}_5$  and 920-1589 mg/l of COD. The pH ranged from 2 - 7. Source of the contamination comes from three streams; leaks and spills - 15 percent, scrubbers - 50 percent and startup slop - 35 percent.

## $\text{SO}_3$ SOLVENT AND VACUUM SULFONATION -- (PROCESS 203)

### Introduction

Compared to the Air- $\text{SO}_3$  process, these techniques are used infrequently. Usually they will be batch operations and relatively small. Leaks, spills and washouts will be the main source of contamination. No data specific to these processes was obtained or submitted, but it is believed that effluents and

contaminants will be essentially the same as for Air-SO<sub>3</sub> sulfonation, Process 202.

#### Waste Water Balance

No direct process water will be used, but a small stream will be used for cleanup of leaks and spills. Cooling water will be indirect. It is possible that operators will use barometric condensers to maintain the vacuum and to strip solvent, which is usually SO<sub>2</sub>. If barometrics are used, there could be a large volume effluent with low concentrations of MBAS, oil and sulfite.

#### Waste Water Constituents

Leaks and spills will consist of raw materials and products. These will include alkylbenzenes, alcohols and ethoxylated alcohols; sulfonic acids and sulfuric acid esters. These constituents will contribute BOD<sub>5</sub>, COD, acidity, dissolved solids, sulfate, sulfite oil, and MBAS to effluent waste waters.

### SULFAMIC ACID SULFATION -- (PROCESS 204)

#### Introduction

Sulfamic acid is used to sulfate alcohol and alkylphenol ethoxylates, but seldom for other raw materials. The reaction is run batchwise and requires relatively simple equipment. The ammonium salt of the ether sulfate is obtained directly, so it is only necessary to dilute the product with the chosen solvent.

#### Water and Waste Water Balance

No process water is used and cooling or heating water will be non-contact.

#### Waste Water Constituents

A small amount of contamination will come from leaks and spills, but a major effluent comes from washing out the reactor between batches. This is necessary since the solvent (water or alcohol) will react with the sulfamic acid.

Data submitted by industry indicates that 30 kg of BOD<sub>5</sub> and 60 kg of COD is added to waste waters per kkg (30 lb and 60 lb/1000 lb) of ammonium ether sulfate produced. This is understandable since the product is viscous and surface to volume ratio of the reactor is high.

### CHLOROSULFONIC ACID SULFATION -- (PROCESS 205)

#### Introduction

This process is used to produce high quality alcohol and ether sulfates for specialty surfactant use. Leaks, spills and reactor

washout will be the main source of organic contaminants. Since HCl is a by-product it may be absorbed in water or caustic and sent to the sewer.

#### Water and Waste Water Balance

The only process water used is for absorbing HCl. Cooling water is non-contact and should remain uncontaminated.

Contaminants found in leaks and spills will be the alcohols or alkylphenol and alcohol ethoxylates used for feedstocks. Also, chlorosulfonic acid hydrolysis products (HCl and H<sub>2</sub>SO<sub>4</sub>) can be expected, plus the sulfated surfactants. The same materials will be in the other waste waters.

Since it is not necessary to clean out the reactor between batches, raw waste loads will be similar to other sulfonation processes; i.e., S03-Air. An average of 3 kg (3 lb) of BOD<sub>5</sub> and 9 kg (9 lb) of COD per kkg (1000 lb) of sulfated product was found. Sizable amounts of acidity and chloride (5 kg/kkg) (5 lb/1000 lb) can also be expected if the HCl is sent to the sewer, but many plants recover it and sell it as muriatic acid.

#### NEUTRALIZATION OF SULFURIC ACID ESTERS & SULFONIC ACIDS -- (PROCESS 206)

##### Introduction

This process is used to convert the sulfated and sulfonated alkylbenzenes and alcohols to neutral salts. Various bases are used depending on the required characteristics of the final surface active agent. The dry neutralization process (2063) is infrequently used in the United States to make consumer products falling within SIC 2841. However, some industrial products will be made in this manner. Most salts are made by liquid neutralization (2062). Plants making neutralized products range from a small batch kettle of a few thousand kilograms capacity to several million kilograms per day continuous process units.

##### Water and Waste Water Balance

Waste waters from these plants come almost entirely from leaks and spills, with washouts occasionally contributing (206102 and 206202). Indirect cooling water is used since the neutralization is exothermic, but contamination should be very rare. No process water is involved.

##### Waste Water Constituents

All of the anionic surface active agents used in soaps and detergents will be found in these waste waters. Also the inorganic salts, such as sodium sulfate, from neutralization of excess sulfuric acids will be found. Alkylbenzene sulfonates, ether sulfates, alcohol sulfates, olefin sulfonates, with the



ammonium, potassium, sodium, magnesium and triethanol ammonium cations will be represented.

These constituents will contribute to BOD<sub>5</sub> and COD, MBAS dissolved solids, Kjeldahl ammonium nitrogen, sulfate, acidity and alkalinity.

The total amount of contaminants contributed from this process is quite small. The equipment used has stood the tests of time. Of course there will always be occasional leaks and spills. Whether a plant recycles or discharges to a sewer determines the concentration of contaminants and water usage. When recycle is practiced, as little as 10.4 l/kg (1.25 gal./1000 lb) of water is used. Concentrations in this case were high - 6000 mg/l of BOD<sub>5</sub> and 21,000 mg/l of COD. The other extreme was 4170 l (1100 gal.) of water - a BOD<sub>5</sub> of 85 mg/l and a COD of 245 mg/l.

Because of the variety of products made we observed quite a range of waste loadings: BOD<sub>5</sub> - 0.07 kg - 0.8 kg/kg (0.07 lb - 0.81 lb/1000 lb) of product, COD - 0.2 kg - 2.3 kg (0.2 lb - 2.3 lb), MBAS - 0.1 kg - 3.1 kg (0.1 lb - 3.1 lb).

#### SPRAY DRIED DETERGENTS -- (PROCESS 207)

##### Introduction

This is probably the single largest volume unit process utilized by the soap and detergent industry. There is great variation in the operation of spray towers insofar as water use and reuse is concerned. These variations result from different processing characteristics of product formulas, influences of air quality problems, standards and frequency of product changeovers, and plant integration.

The principal sources of contaminated water are washdown of the tower - 207312; scrubber waters - 207301 and 207330; and leaks and spills - 207202 and 207302.

##### Water and Waste Water Balance

No cooling water is used in this process. All process water which is added to the crutcher leaves the process as water vapor from the spray tower (207308). Therefore, all water used is for various types of cleanup. Some plants employ total recycle of cleanup water and therefore have a very low rate of discharge. Some plants discharge all waste waters to the municipal sewer. Most plants are intermediate and specific problems must be recognized to be able to understand water disposal practices.

To be able to maintain desirable air quality it may be necessary to use very large quantities of water for scrubbing organics from spray tower vent gases. This problem is still under study. Frequent product changeovers for smaller plants make it economically and physically impossible to collect and recycle all

tower washouts. Highly integrated plants have more opportunities to recycle or use detergent-laden waste waters.

Typical water usage associated with spray tower operations include: wet scrubbing of air emissions, 30-200 gal/1000 lb; equipment washouts (crutchers, spray towers, packaging, etc.), 5-55 gal/1000 lb; and clean-up of leaks and spills, 2-20 gal/1000 lb. Total waste water discharges encountered ranged from less than 5 gal/1000 lb to as much as 250 gal/100 lb.

Waste Water Constituents

All of the streams will be contaminated with the detergent being produced in the plant at the time. The various surfactants, builders and additives are listed on the flow diagram entering 2071 Receiving Storage And Transfer.

These constituents will contribute to BOD<sub>5</sub>, COD, MBAS, dissolved and suspended solids, oil and grease and alkalinity.

Average raw waste loads for the three types of operation of spray towers are tabulated as follows (kg/kg dry detergent) (lb/1000 lb):

	BOD <sub>5</sub>	COD	Suspended Solids	Surfactants	Oil and Grease
Few turnarounds & no air quality problem	0.1	0.3	0.1	0.2	nil
Air quality problems	0.8	2.5	1.0	1.5	0.3
Fast turn-around	0.2	0.4	0.2	0.4	0.03

LIQUID DETERGENT MANUFACTURE -- (PROCESS 208)

Introduction

Manufacture of liquid light-duty hand dishwashing and heavy-duty laundry detergents requires relatively simple equipment for blending the various ingredients. Usually this is done batchwise with the several surfactants being added by weight, and then thoroughly blended.

Filling of the bottles is done on sophisticated high speed filling lines. This is a most critical and difficult operation because of machine complexity, speed, and cost.

From the filling line, leaks, spills and overflows are sources of water contamination (208302). From both the blending and filling operations, purging the lines between products produce slugs of

detergent contaminated water (208212, 208213 and 208302). Also, filled detergent bottles are sometimes washed (208310).

Contaminants from light-duty liquid detergents are very high in surface active agents. Heavy-duty liquid detergents, produced in much lower volume, can result in some contamination with builders (phosphates, carbonates).

#### Water and Waste Water Balance

Liquid detergents consume water as the major solvent for the product. Little or no water is used for heating and cooling, but large amounts of water are used for washing equipment and packages. Because very small amounts of liquid detergents can cause extraordinary amounts of foam, it is necessary to use very large volumes of water; and recycle or reuse of water becomes impracticable. Reported water usage was in the range of 625-6250 l/kg (75-750 gal/1000 lb) of detergent.

#### Waste Water Constituents

All of the effluent streams will contain the starting ingredients of the products. These are mainly:

ammonium, potassium & sodium alkylbenzene sulfonates (LAS)

ammonium, potassium & sodium alcohol ethoxy sulfates (AES)

ammonium, potassium & sodium alkylphenol ethoxy sulfates

ammonium, potassium & sodium olefin sulfonates (OS)

ammonium, potassium & sodium toluene and xylene sulfonates (hydrotropes)

ammonium, potassium & sodium alcohol sulfates

Fatty acid alkanol amine condensates (amides)

Urea (hydrotrope)

Ethanol (hydrotrope)

Polyacrylates and polystyrene (opacifiers)

Dyes & perfume

Phosphate & citrate builders

Silicate builders

These constituents will contribute to alkalinity, BOD<sub>5</sub>, COD, nitrogen, MBAS (and undetected surfactants) and dissolved solids.

Raw waste loadings vary more in concentration than total amount between plants. The following were observed:

	<u>kg/kkg of detergent</u>	<u>mg/l</u>
BOD <sub>5</sub>	0.5 - 1.8	65 - 3400
COD	1.0 - 3.1	120 - 7000
MBAS	0.4 - 1.1	60 - 2000

As much as 90 percent of the detergent can come from washout of tanks and lines when changing products. With fewer changes waste loads will decrease, but the lower levels in the above table represent minimum with current practice.

#### DETERGENT MANUFACTURING BY DRY BLENDING -- (PROCESS 209)

##### Introduction

Production of detergents by this process requires no water for processing and can be operated without using water for washdown. Dry builders and surfactants are simply mixed, or liquid surfactants are sprayed into dry powders so that the entire mass stays free flowing. Some water may also be sprayed onto the dry powders to produce more stable hydrates.

#### DRUM DRIED DETERGENTS -- (PROCESS 210)

##### Introduction

In this detergent drying process, the aqueous slurry of detergent is dried on steam heated rolls and recovered as flakes. Little or no formulated household detergent is now made by this process. Most of the products are high active LAS products for dry blending of industrial detergent products.

##### Water and Waste Water Balance

The detergent slurry contains water added in the neutralization process No. 206. This water is removed as steam and vented to the atmosphere or scrubbed (201201). Steam condensate is generated also, but this should be free of contamination (210203).

##### Waste Water Constituents

The only appreciable effluent will be similar to, but lower in concentration than the scrubber water from spray drying (207301). Surfactants, builders, and free oils can be expected. These will contribute to BOD<sub>5</sub>, COD, alkalinity, MBAS, dissolved solids and oil and grease.

#### DETERGENT BARS AND CAKES -- (PROCESS 211)

This process is similar in operation to Process 106 Bar Soaps. The significant difference arises in the more frequent washouts required because of the heat sensitivity of the detergent active ingredient. Wash waters will be similar in character to those of spray dried detergents.

In some instances soap will also be found in the waste water since it is a part of the blend comprising some toilet bar soaps.

## SECTION VI

### POLLUTANT PARAMETERS

#### Introduction

This section contains a discussion of the specific contaminants which were selected for guidelines recommendations, and those which were omitted. Rationales for the decisions are given for each pollution parameter.

Production of soaps and detergents results in numerous waste water streams and several types of contaminants which are of special concern. Synthetic surface active agents not only create a BOD<sub>5</sub> and COD, but also cause water to foam and in high concentrations can be toxic to fish and other organisms. Nutrients, particularly phosphate, are of concern because of their contribution to eutrophication of lakes. Soap production leads to waste waters with high alkalinity, high salt, and high oxygen demand. Spills of raw materials contribute to oil and grease levels. Most of the suspended solids come from organics; i.e., calcium soaps, and many are of the volatile rather than non-volatile type. Since strong acids and strong alkalies are used, pH can be very high or very low in waste waters.

#### CONTROL PARAMETER RECOMMENDATIONS

To monitor the quality of the treated waste water flows coming from soap and detergent plants as point source discharges, the key parameters recommended for sampling and analysis and structure of guidelines are:

#### Biochemical Oxygen Demand

All of the organic active materials found in soap and detergent formulations are biodegradable in varying degrees. Most are totally and rapidly assimilated, and thus may adversely affect the oxygen balance of receiving waters. Although highly criticized for its lack of reliability, the analytical method for BOD<sub>5</sub> is still the only generally accepted method for grossly measuring the potential impact on the environment. Unfortunately, not all of the organic materials found in these waste water flows contribute to the oxygen demand at the same rate. Some may inhibit the microorganisms which degrade these contaminants, and others are incorporated into the cell tissue of the microorganisms at different rates. This leads to varying ratios of BOD<sub>5</sub> values when compared to the companion COD test.

There are a number of factors which tend to reduce reliability of the BOD<sub>5</sub> in actual practice. One difficulty stems from the frequent need for long term acclimation of the biota to the

special unique organic substrates encountered in the waste streams from the manufacture of detergents. Too often biota are employed in the BOD<sub>5</sub> tests which are totally unacclimated, or at best only partially acclimated. When data derived from such testing are viewed in isolation they tend to indicate that a large quantity of such organics are resistant to biodegradation or are only slowly degraded. However, detailed studies carried out with thoroughly acclimated microbial systems do not support this casual observation. In fact, the vast bulk of the materials now employed as synthetic detergents are subject to rapid and complete assimilation by acclimated saprophytic microorganisms. Industrial surfactants production does lead to a higher refractory component than the household surfactants.

The use of the BOD<sub>5</sub> test is recommended. However, it is essential that acclimated biota be maintained, especially where the concerned effluent originates from a plant producing industrial cleaners.

Biochemical oxygen demand (BOD) is a measure of the oxygen consuming capabilities of organic matter. The BOD does not in itself cause direct harm to a water system, but it does exert an indirect effect by depressing the oxygen content of the water. Sewage and other organic effluents during their processes of decomposition exert a BOD, which can have a catastrophic effect on the ecosystem by depleting the oxygen supply. Conditions are reached frequently where all of the oxygen is used and the continuing decay process causes the production of noxious gases such as hydrogen sulfide and methane. Water with a high BOD indicates the presence of decomposing organic matter and subsequent high bacterial counts that degrade its quality and potential uses.

Dissolved oxygen (DO) is a water quality constituent that, in appropriate concentrations, is essential not only to keep organisms living but also to sustain species reproduction, vigor, and the development of populations. Organisms undergo stress at reduced DO concentrations that make them less competitive and able to sustain their species within the aquatic environment. For example, reduced DO concentrations have been shown to interfere with fish population through delayed hatching of eggs, reduced size and vigor of embryos, production of deformities in young, interference with food digestion, acceleration of blood clotting, decreased tolerance to certain toxicants, reduced food efficiency and growth rate, and reduced maximum sustained swimming speed. Fish food organisms are likewise affected adversely in conditions with suppressed DO. Since all aerobic aquatic organisms need a certain amount of oxygen, the consequences of total lack of dissolved oxygen due to a high BOD can kill all inhabitants of the affected area.

If a high BOD is present, the quality of the water is usually visually degraded by the presence of decomposing materials and

algae blooms due to the uptake of degraded materials that form the foodstuffs of the algal populations.

#### Chemical Oxygen Demand

Chemical oxygen demand (COD) is another measure of oxygen consuming pollutants in water. COD differs from BOD, however, in that COD is a measure of the total oxidizable carbon in the waste and relates to the chemically-bound sources of oxygen in the water (i.e., nitrate which is chemically expressed as  $\text{NO}_3$ ) as opposed to the dissolved oxygen. Materials exerting COD are not readily biodegraded (as is the case, for example, with the complex chemicals, i.e., long chain fatty acids, from soap and detergent manufacturing) and as a result chemical balances in streams are altered. Since COD is usually encountered coincident with BOD, the combined effect is highly deleterious. Because of the difficulty discussed in the preceding section concerning the reliability of  $\text{BOD}_5$ , it is recommended that the COD be used as a primary parameter for characterizing effluents from this industry. Special attention must be given to insure the complete oxidation of these materials.

#### Total Suspended Solids

Although the waste water sources of the soap and detergent industry are not notably heavy in suspended solids, suspended solids should be monitored to insure that stream clarity is not unduly affected or sludge deposits formed on the stream bed, particularly by some upset in the processing train.

Suspended solids include both organic and inorganic materials. The inorganic components include sand, silt, and clay. The organic fraction includes such materials as grease, oil, tar, animal and vegetable fats, various fibers, sawdust, hair, and various materials from sewers. These solids may settle out rapidly and bottom deposits are often a mixture of both organic and inorganic solids. They adversely affect fisheries by covering the bottom of the stream or lake with a blanket of material that destroys the fish-food bottom fauna or the spawning ground of fish. Deposits containing organic materials may deplete bottom oxygen supplies and produce hydrogen sulfide, carbon dioxide, methane, and other noxious gases.

In raw water sources for domestic use, state and regional agencies generally specify that suspended solids in streams shall not be present in sufficient concentration to be objectionable or to interfere with normal treatment processes. Suspended solids in water may interfere with many industrial processes, and cause foaming in boilers, or encrustations on equipment exposed to water, especially as the temperature rises. Suspended solids are undesirable in water for textile industries; paper and pulp; beverages; dairy products; laundries; dyeing; photography; cooling systems, and power plants. Suspended particles also



serve as a transport mechanism for pesticides and other substances which are readily sorbed into or onto clay particles.

Solids may be suspended in water for a time, and then settle to the bed of the stream or lake. These settleable solids discharged with man's wastes may be inert, slowly biodegradable materials, or rapidly decomposable substances. While in suspension, they increase the turbidity of the water, reduce light penetration and impair the photosynthetic activity of aquatic plants.

Solids in suspension are aesthetically displeasing. When they settle to form sludge deposits on the stream or lake bed, they are often much more damaging to the life in water, and they retain the capacity to displease the senses. Solids, when transformed to sludge deposits, may do a variety of damaging things, including blanketing the stream or lake bed and thereby destroying the living spaces for those benthic organisms that would otherwise occupy the habitat. When of an organic and therefore decomposable nature, solids use a portion or all of the dissolved oxygen available in the area. Organic materials also serve as a seemingly inexhaustible food source for sludgeworms and associated organisms.

Turbidity is principally a measure of the light absorbing properties of suspended solids. It is frequently used as a substitute method of quickly estimating the total suspended solids when the concentration is relatively low.

#### Surfactants (MBAS)

Because of their possible contribution to foaming in streams and biological upset through surface effects or toxicity, measurement and control of the organic active ingredient in effluents is necessary. Not all organic active materials are measured by the MBAS procedure. Soaps are not detected, nor are non-ionics. However, both of the latter are measured by the BOD<sub>5</sub> and COD methods.

#### Oil and Grease

These materials which contribute to visual and olfactory esthetic problems, exert oxygen demand, and interfere with normal oxygen transfer from air to water need to be controlled. The analytical method picks up not only the fatty oils and grease used in the soap making process, but any hydrocarbon bodies which are generated from the synthetic detergent portion of the plant processes. The test method does not distinguish between the two sources, therefore, the results must be interpreted with discretion.

Oil and grease exhibit an oxygen demand. Oil emulsions may adhere to the gills of fish or coat and destroy algae or other

plankton. Deposition of oil in the bottom sediments can serve to exhibit normal benthic growths, thus interrupting the aquatic food chain. Soluble and emulsified material ingested by fish may taint the flavor of the fish flesh. Water soluble components may exert toxic action on fish. Floating oil may reduce the re-aeration of the water surface and in conjunction with emulsified oil may interfere with photosynthesis. Water insoluble components damage the plumage and costs of water animals and fowls. Oil and grease in a water can result in the formation of objectionable surface slicks preventing the full aesthetic enjoyment of the water.

Oil spills can damage the surface of boats and can destroy the aesthetic characteristics of beaches and shorelines.

#### pH, Acidity and Alkalinity

This is a pollutant characteristic important for control since there are occasional upsets in those portions of the processes which could potentially lead to highly acidic or alkaline spills and upset the normal regimen of the receiving waters.

Acidity and alkalinity are reciprocal terms. Acidity is produced by substances that yield hydrogen ions upon hydrolysis and alkalinity is produced by substances that yield hydroxyl ions. The terms "total acidity" and "total alkalinity" are often used to express the buffering capacity of a solution. Acidity in natural waters is caused by carbon dioxide, mineral acids, weakly dissociated acids, and the salts of strong acids and weak bases. Alkalinity is caused by strong bases and the salts of strong alkalies and weak acids.

The term pH is a logarithmic expression of the concentration of hydrogen ions. At a pH of 7, the hydrogen and hydroxyl ion concentrations are essentially equal and the water is neutral. Lower pH values indicate acidity while higher values indicate alkalinity. The relationship between pH and acidity or alkalinity is not necessarily linear or direct.

Waters with a pH below 6.0 are corrosive to water works structures, distribution lines, and household plumbing fixtures and can thus add such constituents to drinking water as iron, copper, zinc, cadmium and lead. The hydrogen ion concentration can affect the "taste" of the water. At a low pH water tastes "sour". The bactericidal effect of chlorine is weakened as the pH increases, and it is advantageous to keep the pH close to 7. This is very significant for providing safe drinking water.

Extremes of pH or rapid pH changes can exert stress conditions or kill aquatic life outright. Dead fish, associated algal blooms, and foul stench are aesthetic liabilities of any waterway. Even moderate changes from "acceptable" criteria limits of pH are deleterious to some species. The relative toxicity to aquatic

life of many materials is increased by changes in the water pH. Metalocyanide complexes can increase a thousand-fold in toxicity with a drop of 1.5 pH units. The availability of many nutrient substances varies with the alkalinity and acidity. Ammonia is more lethal with a higher pH.

The lacrimal fluid of the human eye has a pH of approximately 7.0 and a deviation of 0.1 pH unit from the norm may result in eye irritation for the swimmer. Appreciable irritation will cause severe pain.

#### Parameters Omitted

Among the parameters omitted is dissolved solids. While there will be times of high concentrations of salts in some of the waste water flows within the plant, by the time they are commingled with the total plant effluent they will be quite dilute. In addition, the salts themselves are not in a toxicity range of concern. If the contamination of the waters by dissolved solids could be damaging, the permit granting authority should then issue specific guidelines covering that particular situation.

#### Nitrogen

Nitrogen, although important in the general concern in regard to the quality of the receiving waters, is omitted since there is at this time very little use of products derived from nitrogen. Spot checks of industrial effluents and contractor's analysis of Corps of Engineers permit applications confirmed this observation.

#### Phosphorus and Boron

Phosphate and boron levels found in the raw wastes and treated effluents from plants manufacturing soaps and detergents are comparable to those encountered in the influents and effluents of well operated municipal treatment plants. Moreover, measures to control the selected parameters will effectively control phosphate and boron levels. While the importance of phosphorus as a nutrient (and a potential cause on nuisance aquatic growths) is well recognized, it is questionable that complete elimination of all phosphates from point source discharges in this industry would have a detectable affect on phosphorus levels in any but the most exceptional receiving waters.

During the past 30 years, a formidable case has developed for the belief that increasing standing crops of aquatic plant growths, which often interfere with water uses and are nuisances to man, frequently are caused by increasing supplies of phosphorus. Such phenomena are associated with a condition of accelerated eutrophication or aging of waters. It is generally recognized that phosphorus is not the sole cause of eutrophication, but

there is evidence to substantiate that it is frequently the key element in all of the elements required by fresh water plants and is generally present in the least amount relative to need. Therefore, an increase in phosphorus allows use of other, already present, nutrients for plant growths. Phosphorus is usually described, for this reasons, as a "limiting factor."

When a plant population is stimulated in production and attains a nuisance status, a large number of associated liabilities are immediately apparent. Dense populations of pond weeds make swimming dangerous. Boating and water skiing and sometimes fishing may be eliminated because of the mass of vegetation that serves as an physical impediment to such activities. Plant populations have been associated with stunted fish populations and with poor fishing. Plant nuisances emit vile stenchs, impart tastes and odors to water supplies, reduce the efficiency of industrial and municipal water treatment, impair aesthetic beauty, reduce or restrict resort trade, lower waterfront property values, cause skin rashes to man during water contact, and serve as a desired substrate and breeding ground for flies.

Phosphorus in the elemental form is particularly toxic, and subject to bioaccumulation in much the same way as mercury. Colloidal elemental phosphorus will poison marine fish (causing skin tissue breakdown and discoloration). Also, phosphorus is capable of being concentrated and will accumulate in organs and soft tissues. Experiments have shown that marine fish will concentrate phosphorus from water containing as little as 1 ug/l.

#### Scope of Parameter Measurements - By Processes

Each of the individual processes of the soap and detergent industry are reviewed in the following paragraphs in order to relate the significance of the parameters chosen for guidelines to the measurement of the contaminants contained in waste water flows originating in each unit process.

The ways in which effluent discharge can be monitored are suggested.

#### SOAP MANUFACTURE BY BATCH KETTLE (101)

Significant contaminants from this process are the fats and oils used as raw material; unrecovered sodium chloride, sodium sulfate and sodium hydroxide; soaps that are spilled or lost and dark colored by-product soaps. Limits are proposed for BOD<sub>5</sub> and COD, suspended solids, oil and grease and a range of 6 - 9 for pH. The soaps, fats and oils will be controlled by the first four

tests. A pH in the 6 - 9 range will insure against discharge of sodium hydroxide or strong acids.

Since soap plant wastes can cause depletion of dissolved oxygen, limitation is necessary. Oils and suspended solids cause esthetic problems. A very high or very low pH is detrimental to almost all organisms.

No recommendation has been made for specific limitations of the two inorganic salts, NaCl and Na<sub>2</sub>SO<sub>4</sub>. These are relatively non-toxic (NaCl 10,000-20,000 mg/l MLD; Na SO. 11,000-17,600 mg/l MLD), and most receiving waters are below the limits of dissolved salts set by the United States Public Health Service.

#### FATTY ACIDS BY FAT SPLITTING (102)

The organic compounds from this process are primarily fatty acids although some unreacted fat and glycerine from spills and leaks will also be found. The total of the inorganics will be low compared to the organics. Sodium hydroxide and sodium sulfate from fat pretreatment and from treatment of still bottoms are expected.

Total organics should be controlled by setting BOD<sub>5</sub> and COD limits. Free fatty acids and fats should be controlled by setting oil and grease and suspended solids limits. The pH should be controlled.

Contaminants not limited are the generally innocuous sodium sulfate plus small amounts of zinc and alkaline earth metals used as the fat splitting catalyst and nickel used as a hydrogenation catalyst. These metals ions are below harmful concentration in commingled plant wastes and are further reduced in biological treatment processes which must be used on the organic contaminants.

#### SOAP BY FATTY ACID NEUTRALIZATION (103)

Except for fats and oils the contaminants from this process will be the same as from the kettle boil soap process. Concentrations and loadings are much lower, however.

Control of discharge is established by setting limits on BOD<sub>5</sub>, COD, pH, suspended solids and oil and grease.

The small amount of sodium chloride relative to the production of soap should not require regulation unless the receiving stream is at a critical chloride level.

#### GLYCERINE RECOVERY (104)

Contaminants in waste waters from this process are water soluble organics and two inorganic salts. The organics are glycerine and glycerine polymers. The salts are NaCl and Na<sub>2</sub>SO<sub>4</sub>.

Organics discharge is controlled by setting BOD<sub>5</sub> and COD limits. Although pollutants affecting pH, suspended solids, and oil and grease are minimal, limits have been set to guard against carry over from previous processing steps.

Sodium chloride and sodium sulfate should not be restricted unless the receiving stream is close to the specified limit for chloride and sulfate ions.

#### SOAP FLAKES AND POWDERS (105)

Effluents from this process are minimal. Since almost pure soap is processed, the contaminants will be primarily soap with only small amounts of free fatty matter, alkali and salt.

BOD<sub>5</sub> and COD are used to limit discharge of soaps, and pH is to be kept to the 6 - 9 range. Suspended solids and oil and grease should be measured to guard against unusual contamination.

Although sodium chloride is not limited, its concentration should be negligible.

#### BAR SOAPS (106)

As with soap flakes and powders, waste water contaminants from this process will be mainly soap. Small amounts of salt and alkali which are in the soap will also be found. Some free fatty matter and additives can be expected in the waste waters.

Assignment of BOD<sub>5</sub> and COD limits will control the discharge of soap. Specifying limits for pH, oil and grease, and suspended solids will handle unusual spills.

Inorganic contaminants should be low and control should be unnecessary.

#### LIQUID SOAP (107)

Liquid soaps are formulated products and will contain solvents, builders, dyes and perfumes in addition to potassium soaps. Almost all contamination will come from spills so the waste water will be contaminated with all constituents of the formula.

BOD<sub>5</sub> and COD limits will control overall discharge of organics. Control of pH to the 6.0 - 9.0 level should present no problem since the product will be in that range. The suspended solids and oil and grease tests will be more important here than with other soaps since the formulated soaps often contain hydrocarbon solvents.

Inorganic salts should be negligible from this process and thus require no control. Potassium ion will be found here but the level should be low enough to require no limitations.

### OLEUM SULFONATION AND SULFATION (201)

In effluents from this process, one can expect to find the oily raw materials, sulfuric acid and surfactant sulfonic acids. All of these contaminants need to be treated before discharge.

Raw material spills should be limited by setting specifications for the oil and grease and suspended solids. The MBAS test can measure surface active sulfuric acid esters and be used to limit their concentration. Total organic contamination can be monitored and controlled by running the oxygen demand procedures, BOD<sub>5</sub> and COD. Sulfuric acid and sulfonic acids are very strong acids and must be neutralized before discharge. This can be assured by specifying a pH of 6 - 9.

The only contaminant not limited is sulfate. Most streams can absorb current quantities of this ion, but if necessary the regional permit officer can restrict discharge of sulfate.

### AIR SO<sub>3</sub> SULFATION - SULFONATION (202)

This process is identical to process 201 with respect to contaminant composition. However, the levels of contamination are higher.

Limitations have been set for BOD<sub>5</sub>, COD, pH, oil and grease, MBAS and suspended solids. Sulfate need not be limited for the usual receiving water.

See the discussion under Process 201 for the rationale.

### VACUUM AND SOLVENT SULFONATION (203)

This process is identical to process 201 insofar as contamination is concerned. One exception is the possible presence of sulfate in the waste water. Levels should be similar to process 201.

Limits have been set for BOD<sub>5</sub>, COD, pH, oil and grease and suspended solids. Sulfate should generally be exempted.

For rationale see Section 201.

### SULFAMIC ACID SULFATION (204)

This reaction is rather limited in scope, but can have a high discharge because of washdown after each batch. Contaminants will be unsulfated ethoxy alcohols, sulfamic acid and ammonium ether sulfates.

The MBAS test and a limitation for the process will be most useful for control. Because the MBAS test does not pick up nonionic surfactants, BOD<sub>5</sub> and COD are needed to control the overall organic load. As usual, pH control will be needed since sulfamic acid is a strong acid.

Sulfamic acid hydrolyzes to ammonium acid sulfate in water so that no control is needed unless the receiving water is close to its limit for nitrogen and sulfate.

The organic contaminants from this process will be feedstock, fatty alcohols, alcohol ethoxylates and alkyl phenol ethoxylates. Also, the sulfated products and the final ammonium, sodium and triethanol amine salts will be found. Inorganics will be hydrochloric and sulfuric acids plus ammonium and sodium ions.

Limitations have been established for total organics by specifying BOD<sub>5</sub> and COD values. MBAS should be measured and controlled. Raw material spills can be controlled by specifying suitable values for oil and grease and suspended solids. As usual, pH needs adjustment to the 6.0 - 9.0 level.

#### NEUTRALIZATION OF SULFURIC ACID ESTERS AND SULFONIC ACIDS (206)

In this process the organic acids produced by sulfation and sulfonation are reacted with bases to produce the desired salts. Therefore, contaminants will be the products of processes 201, 202 and 203. In addition, the neutralized products and the various cations will be present.

The MBAS test, and a limitation thereon, will be important in controlling contamination from this process. BOD<sub>5</sub> and COD allowances will determine overall organic contamination. To assure a neutral waste water, pH adjustment will be necessary. Oil and grease and suspended solids should be minimal but specifications are needed for unusual spills.

Control of inorganic sulfate, potassium, sodium and ammonium ions is believed unnecessary for most receiving streams.

#### SPRAY DRIED DETERGENTS (207)

Effluents from this process will contain all of the many ingredients used in dry detergent powders: LAS, amide, nonionic and alcohol surfactants: sodium phosphate, carbonate and silicate builders; carboxymethyl cellulose, brighteners, perborate, dyes, fillers and perfumes.

An MBAS limit will handle anionic surfactants, but COD and BOD<sub>5</sub> tests are needed to estimate other surfactants. Careful attention needs to be paid to BOD<sub>5</sub>/COD ratio since the various surfactants can inhibit or react slowly with unacclimated BOD<sub>5</sub> cultures.

The suspended solids test will serve to limit insolubles and the oil and grease limit is needed for spill of oils from the spray tower.

Specific limits have not been recommended for carbonate, silicate, phosphate and sodium ions. The condition of the



receiving stream should be determined by the permit officer before limiting these contaminants.

#### LIQUID DETERGENTS (208)

These products are made by simple blending so effluents will contain the starting ingredients. High levels of organic surface active agents can be expected from washdown and cleanup. Heavy-duty liquid detergents will also contain potassium phosphate, silicate and citrate builders and solvents (ethanol). Hydrotropes (sodium xylene sulfonate and urea) will also be found.

To control total organics the BOD<sub>5</sub> and COD levels have been specified. MBAS limits have been set to control the important anionic surfactants. Limits on pH, oil and grease, and suspended solids have been set but control measures should be unnecessary.

Except for the generally innocuous inorganic salts, levels for all contaminants have been specified.

#### DRY DETERGENT BLENDING (209)

This process usually has a very low effluent level. Any contaminants will be the same as those discussed in Section 207 - spray dried detergents. Our rationale for limiting BOD<sub>5</sub>, COD, pH, suspended solids, MBAS and oil and grease are the same also.

#### DRUM DRIED DETERGENTS (210)

Almost exclusively devoted to the manufacture of industrial detergent powders, this process uses a wide variety of raw materials. They find their way into waste water flows through spills and washouts. BOD<sub>5</sub>, COD and surfactant (MBAS) limits will govern these sources, coupled with pH.

There should be no oil and grease appearing in any waste water from this process.

#### DETERGENT BARS AND CAKES (211)

Processing of detergent bars is almost identical with soap bars. However, the wastes will contain synthetic surfactants. Therefore, in addition to setting limits on BOD<sub>5</sub>, COD, pH, suspended solids and oil and grease, it is necessary to specify a limit on MBAS.

The rationale for the limits and parameters will be found under process 106.

#### Industrial Cleaners

Industrial cleaning compounds are also manufactured in plants of the soap and detergent industry. Insufficient data was obtained to make specific recommendations on the multitude of compounds employed but some guidance can be given. Industrial cleaners make up about 10 percent of the industry output. The studies of the Organic and Inorganic Chemicals Industries are expected to provide much useful treatment data on some of the more exotic chemicals. The phosphates, silicates, carbonates and caustic alkalis which are employed will create the same basic situations as are discussed in processes 207, 208 and 209. Similar treatment procedures and guidelines also apply.

Other material not sufficiently characterized but which might be expected in the industrial waste waters are hydrogen fluoride, sulfamic acid, phenols and cresol, chlorinated hydrocarbons, complex organic and inorganic corrosion inhibitors, and exotic surfactants. Fluorides can be easily precipitated with lime. Sulfamic acid and cresol are readily biodegradable if concentrations are kept low. The chlorinated hydrocarbons may have to be removed by solvent extraction or carbon absorption. Some corrosion inhibitors used in acids for industrial cleaning are complex organics which will require individual study. The exotic surfactants will include phosphoro-, fluoro- and silico-organo compounds which have unknown treatability. Nonionic, amphoteric, and low molecular weight wetting agents with different treatability can also be expected. The limits on BOD<sub>5</sub>, COD, suspended solids, surfactants, oil and grease and pH should effectively control industrial cleaners in the subcategories involved in their production, but the area of industrial cleaners merits additional study.



## SECTION VII

### CONTROL AND TREATMENT TECHNOLOGY

#### Introduction

The key to great reductions in the pollution load from the soap and detergent industry is lower process water usage. Those processes using the most process water per unit mass of product made are also the greatest contributors of pollutants.

One of the biggest improvements would be either changing the operating techniques associated with the barometric condensers or replacing them entirely with surface condensers. Complete replacement would reduce many fold the use of water in most processes and at the same time cut down greatly on the amount of organics now being sent to sewer. These organics normally have a market value (when further purified) which may provide a positive payout on the improvement introduced.

Barometric condenser operation could be greatly improved by recycling the water through a fat skimming operation (where marketable fats and oils could be recovered) and then through cooling towers. The only waste would be a continuous small blowdown from the skimmer to keep soluble materials within acceptable limits. Fat splitting operations which have barometric condensers equipped with such cooling and skimming equipment already meet the recommended guidelines with considerable ease.

Another area where a large reduction in water usage could be effected is in the manufacture of liquid detergents. This can be attained by installation of additional water recycle piping and tankage and by the use of air rather than water to blow out filling lines. This latter change will also minimize the loss of finished product.

One of the large integrated plants making both soaps and detergents has achieved almost zero discharge of pollutants through a painstaking, ten-year effort. One of the first tasks which had to be undertaken, and still the biggest obstacle for most fairly old integrated plants, was identifying and untangling the waste water lines which now lead to the sewer. Only after such identification, monitoring and study could the effluents be managed better.

With few exceptions, the contaminants in waste waters from the soap and detergent industry are really saleable products in disguise, especially those relating to distillation equipment and entrainment separators. Wherever a distillation is carried out, whether on a batch basis or by multi-component continuous fractionation, there is an entrainment of liquid droplets from one tray of a tower to the tray above. This is essential in order to accomplish good vapor-liquid contacting and to make the

efficiency of the physical transfer of the highest possible order. However, it does result in carrying droplets of liquid by the vapor from the stage below to the stage above. The use of one or two additional special trays in a distillation column, whether used in concentration as in glycerine manufacture or used for the separation of components as in fatty acid manufacture, will not only eliminate carryover in the form of entrainment but will lead to a more complete separation and a higher purity of each component of a multi-component distillation feed.

#### NATURE OF POLLUTANTS

The soap and detergent industry produces wastewaters containing both conservative and nonconservative pollutants which must be treated, removed from the waste stream, and ultimately disposed of under controlled conditions. The important nonconservative pollutants consist of organic raw materials, fats and oils and lost portions of finished product, soap and/or synthetic detergent. Mineral solids, catalysts and builder materials such as borate and phosphate also appear in the effluents in moderate concentrations. Some of these substances reach polluting concentrations in plant effluents which then have to be treated. The pollutants of primary concern, together with the concentration ranges within which they are generally found in plant raw waste effluents are as follows:

1. Oils and greases (0-3400 mg/l)
2. Suspended organic material other than oils and greases (0-30,000 mg/l)
3. Dissolved or finely dispersed colloidal organic substances which contribute to the chemical and biochemical oxygen demands. (100-12,000 mg/l)
4. Certain organics with surfactant properties. (0-1700 mg/l)

In addition to pollutants per se, the alkalinity or acidity of wastes is also a primary concern and may mandate the treating of a plant effluent.

Of secondary concern in raw wastes are the following pollutants:

1. Boron or borates (less than 1 mg/l)
2. Phosphates (25-1000 mg/l)
3. Dissolved mineral solids (0-250,000 mg/l)
4. Zinc and barium (less than 1 mg/l)

It should be noted that the higher values in the ranges listed above are representative of small individual waste streams and would not be representative of the total raw effluent for a plant or even a subcategory.

Since phosphate compounds are used in the manufacture of several types of detergent, some of them inevitably find their way into the process waste streams. The concentrations actually measured vary widely and the data are not sufficiently complete to make

absolute judgments concerning typical levels for many of the operations carried out in the industry. However, some generalizations can be made.

In the closely controlled, well operated, integrated manufacturing facilities examined as a part of the present study, where phosphoric acid type cleaners were not being produced, the concentrations of phosphorus contained in the combined raw waste was generally under 25 mg/l as phosphorus. In those same facilities the average concentrations were typically 5-10 mg/l as phosphorus; i.e., of the same order as is contained in domestic sewage.

Table 2 indicates the treatment technology which can be applied to the appropriate waste streams for removal of specific pollutants of concern.

More specific consideration of the best practicable control technology currently available and the best available technology economically achievable is contained in Sections VIII, IX and X.

#### DISCUSSION OF TREATMENT TECHNIQUES

The treatment technologies discussed are standard and in routine use. Operating and design techniques are well established and have been reported upon extensively in the literature. Therefore, only a brief discussion of such operations and processes is included in this report. A list of the major pollutants and treatment methods usually employed to handle them are given in Table 2. Removal efficiencies for some of these treatment methods are given in Table 3.

Oil and Grease Removal - This may be accomplished by the application of any one, or a combination of three basic separation methods - gravity separation, physical filtration, or adsorption. The gravity separators are designed to handle loads of 20,500-41,000 l/day/sq m (500-1,000 gpd/sq ft) of surface. The filters are normally operated at 205-615 l /min/sq m (5-15 gpm/sq ft).

Carbon and other related solid phase adsorption operations require approximately 0.45-0.68 kg (1.0-1.5 lb) of adsorbent per 0.45 kg (1 lb) of oil removed. Flotation operates very much the same as the sedimentation operation in terms of over-all efficiency. Air rates are usually maintained around 0.004-0.011 cu m/min/cu m (0.5-1.5 cu ft/min/100 gal) of recycled flow. Chemical doses of FeCl<sub>3</sub>, alum, or lime vary from 50-150 mg/l.

TABLE 2

Treatment Methods Used in Elimination of Pollutants

<u>Pollutants</u>	<u>Treatments</u>
Free and emulsified oils and greases	<ol style="list-style-type: none"> <li>1. Gravity separation</li> <li>2. Coagulation and sedimentation</li> <li>3. Carbon adsorption</li> <li>4. Mixed media filtration</li> <li>5. Flotation</li> </ol>
Suspended Solids	<ol style="list-style-type: none"> <li>1. Plain sedimentation</li> <li>2. Coagulation-sedimentation</li> <li>3. Mixed media filtration</li> </ol>
Dispersed Organics	<ol style="list-style-type: none"> <li>1. Bioconversion</li> <li>2. Carbon adsorption</li> </ol>
Dissolved Solids (Inorganic)	<ol style="list-style-type: none"> <li>1. Reverse osmosis</li> <li>2. Ion exchange</li> <li>3. Sedimentation</li> <li>4. Evaporation</li> </ol>
Unacceptable Acidity or Alkalinity	<ol style="list-style-type: none"> <li>1. Neutralization</li> </ol>
Sludge obtained from or produced in process	<ol style="list-style-type: none"> <li>1. Digestion</li> <li>2. Incineration</li> <li>3. Lagooning</li> <li>4. Thickening</li> <li>5. Centrifuging</li> <li>6. Wet oxidation</li> <li>7. Vacuum filtration</li> </ol>

Table 3

Relative Efficiency of Several Methods Used in Removing Pollutants

<u>Pollutant and Method</u>	Efficiency (Percentage of Pollutant Removed)
<u>Oil and Grease</u>	
API type separation	Up to 90 percent of free oils and greases. Variable on emulsified oil.
Carbon adsorption	Up to 95 percent of both free and emulsified oils.
Flotation	Without the addition of solid phase, alum or iron, 70-80 percent of both free and emulsified oil. With the addition of chemicals, 90 percent
Mixed media filtration	Up to 95 percent of free oils. Efficiency in removing emulsified oils unknown.
Coagulation-sedimentation with iron, alum or solid phase (bentonite, etc.)	Up to 95 percent of free oil. Up to 90 percent of emulsified oil.
<u>Suspended Solids</u>	
Mixed media filtration	70-80 percent
Coagulation-sedimentation	50-80 percent
<u>Chemical Oxygen Demand</u>	
Bioconversions (with final clarifier)	60-95 percent or more
Carbon adsorption	Up to 90 percent
<u>Residual Suspended Solids</u>	
Sand or mixed media filtration	50-95 percent
<u>Dissolved Solids</u>	
Ion exchange or reverse osmosis	Up to 99 percent



Coagulation and Sedimentation - These units are designed to provide between 30 and 60 minutes of coagulation time and are normally designed for surface loading rates of 16,400-61,500 l/day sq m (400-1500 gpd/sq ft) depending upon the nature of the waste.

Bioconversion Systems - Bioconversion is a biological method of removing pollutants from waste water. Its use involves one or more of the following:

1. Aerated lagoons
2. Extended aeration
3. Activated sludge
4. Contact stabilization
5. Trickling filters

While both aerobic and anaerobic sludge digestion are bioconversion processes, they are not used to remove pollutants directly from the waste stream but rather to further treat materials already removed or currently being generated as a part of the treatment operation. Bioconversion units based on the use of activated sludge or one of the basic modifications thereof are designed on the basis of 90-363 mg (0.2-0.8 lb) of COD per 0.45 kg (1 lb) of dry biomass. Depending upon the nature of the organics, this loading will provide average removals in excess of 80-90 percent with daily maximum discharges not exceeding three times the average discharge. Trickling filter systems are designed in a more empirical fashion using one of the many formulae in the literature relating efficiency to a real loading depth, recycle rate and hydraulic load.

Carbon Adsorption Systems - These are of two general types; those which use a more or less fixed carbon bed, and those which use powdered carbon and recover the spent carbon in an accompanying clarifier. The carbon is usually loaded at rates of 45-227 g (0.1-0.5 lb) of pollutant per 0.45 kg (1 lb) of carbon. At conventional surface loadings, spent powdered carbon is easily recovered in a clarifier after coagulation with inorganic salts or organic polyelectrolytes.

Carbon regeneration is a comparatively new art. While some regenerative type systems do exist, they are neither common nor completely satisfactory. In carbon regeneration, there are a number of technological questions still to be answered. For example, movement of the carbon to the furnace, attrition rates, control of oxygen to prevent explosion. All of these questions should be carefully examined prior to entering upon a major program utilizing the carbon adsorption waste treatment process. However, if the nature of the wastes to be treated clearly indicate the desirability of using the process, the above considerations should not be viewed as absolute deterrents.

Filtration for Removal of Suspended Solids - See discussion of oil removal.

Dissolved Solids Removal - The design of systems for this purpose varies widely with the manufacturer. They are evaluated on the basis of efficiency, water recovery, and the tendency to foul in the presence of suspended material. Most systems require the removal of most of the suspended solids prior to treatment. Some require virtually complete removal of both suspended solids and dissolved organic solids. Over-all water recovery tends to vary from 65-90 percent depending upon the particular system employed and the nature of the waste.

Other Treatment Technique Considerations - In a good part of the soap and detergent industry, the conversion of raw materials and the recovery of reaction by-products is carried out on a batch rather than a continuous basis. This results in effluent streams which flow sporadically and vary greatly in content and volume. Because of this, most soap and detergent plants have devised ways of offsetting such irregular performance and obtaining effluent streams of a more constant nature, usually by providing some system capacitance, frequently in the form of an equalization basin.

While it is not recommended that provision be made specifically for the control of phosphorus, it is recognized that a certain amount of phosphorus is normally degraded in the normal course of waste treatment. The following discussion is presented to indicate how this occurs.

When in the coagulation and sedimentation waste treatment process lime, alum, or a combination of iron salts is used as the primary coagulant for the removal of suspended or colloidal material, the removal of phosphorus may be carried out concomitantly by making minor adjustments in the mode of operation and the handling of the sludge. In many cases, a high degree of removal will be obtained with no change in the standard operating practices. It depends upon the pH levels employed in lime coagulation and the level of aluminum or iron salts employed in polyelectrolyte coagulation. In general, this procedure will produce phosphorus levels well under 1 mg/l and under 0.5 mg/l where an extremely high level of sedimentation performance is obtained.

In the above mentioned waste treatment process, some phosphorus is removed as the phosphate salt of the metal cation employed in the coagulation step. In the case of lime precipitation, pH values in excess of 9.5 are generally required for a high level of removal. The actual value depends on the background calcium in the waste stream and the level of removal required. In the case of ferric or aluminum phosphate precipitation, 1-3 times the stoichiometric quantity will be required for a high degree of removal. As can be seen, these quantities of material do not represent a major addition to the chemical requirements and indeed a high level of phosphate removal may be incidental to suspended and colloidal solids removal. Where phosphorus removal is practiced as a part of an over-all waste treatment operation which includes bioconversion, a sufficient level of phosphorus

must remain in the stream flowing to the biological system to support microbial action. On a weight basis, this is generally of the order of 200 units of COD for each unit of phosphorus.

To facilitate an understanding of the relationship between the various unit processes involved in the over-all waste treatment process, the former have been arranged in the approximate order in which they might occur in a composite waste treatment flow chart in Figure 20. A similar chart for sludge solids handling is presented in Figure 21.

#### SPECIAL OPERATIONAL ASPECTS OF CONTROL TECHNOLOGY

The nature of the treatment scheme proposed herein, coupled with certain basic characteristics of the industry itself, calls for special design and operating techniques in order to achieve satisfactory waste control. The factors involved are discussed briefly in the following paragraphs.

The industry employs many batch operations which tend to produce waste of variable character and quantity. As a consequence, there is often a need for some way of obtaining a more uniform waste stream from the standpoints of both composition and flow. Traditionally this has been done by installing mixed equalization tanks through which the wastes pass prior to being subjected to the principal treatment. However, these units often present operating problems of their own. For example:

1. If the waste is not at biostatic concentrations when it reaches the treatment plant, some bacterial growth will occur in the equalization unit producing solids and tending to reduce the oxidation potential of the system to ineffective levels with accompanying odors and nuisance status.
2. It is necessary to provide a minimum of 0.8 kw/cum (40 hp/1000 gal) to be sure that the wastes in the equalization tank are completely mixed and that sedimentation will not occur.

On the other hand, if an equalization unit is not provided, unit operations and processes which are regulated by flow and concentration will be adversely affected. In minimizing or eliminating the adverse effects of influent surges, the following should be considered:

1. Installation of clarification units which can be kept uniformly over 4 m (12 feet) side water depth. Deep units are much less subject to upsets by variations in surface loading than are shallower units of 3 m (10 ft) or less.
2. If a completely mixed first stage activated sludge bioconversion system is to be employed it should be understood that the effluent quality will vary with the influent strength surges. Effluent quality variations can be handled either by equalization, or by providing a second activated sludge stage of

**COMPOSITE FLOW SHEET  
WASTE TREATMENT  
SOAP & DETERGENT INDUSTRY**

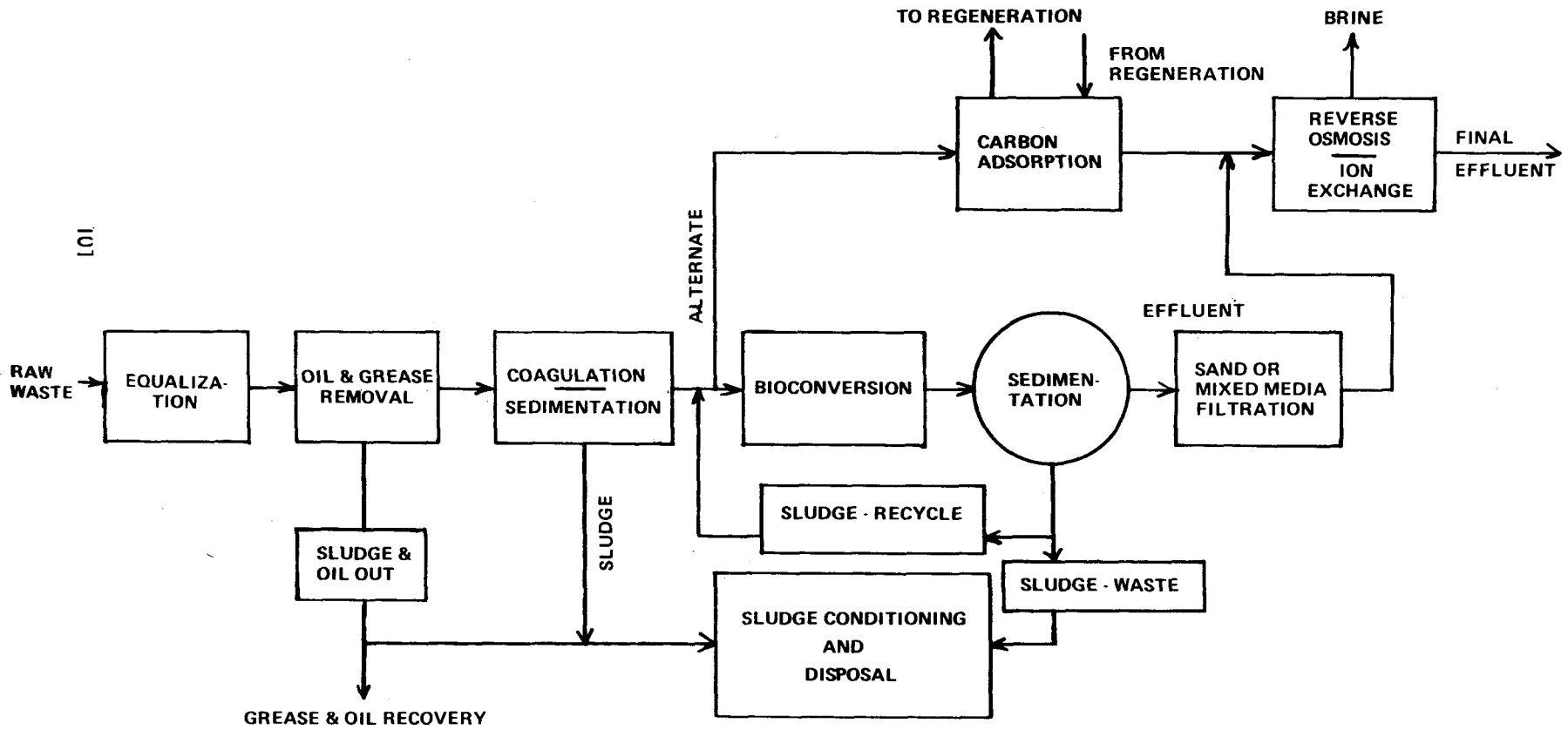

FIGURE 20

# SLUDGE SOLIDS HANDLING SOAP & DETERGENT INDUSTRY

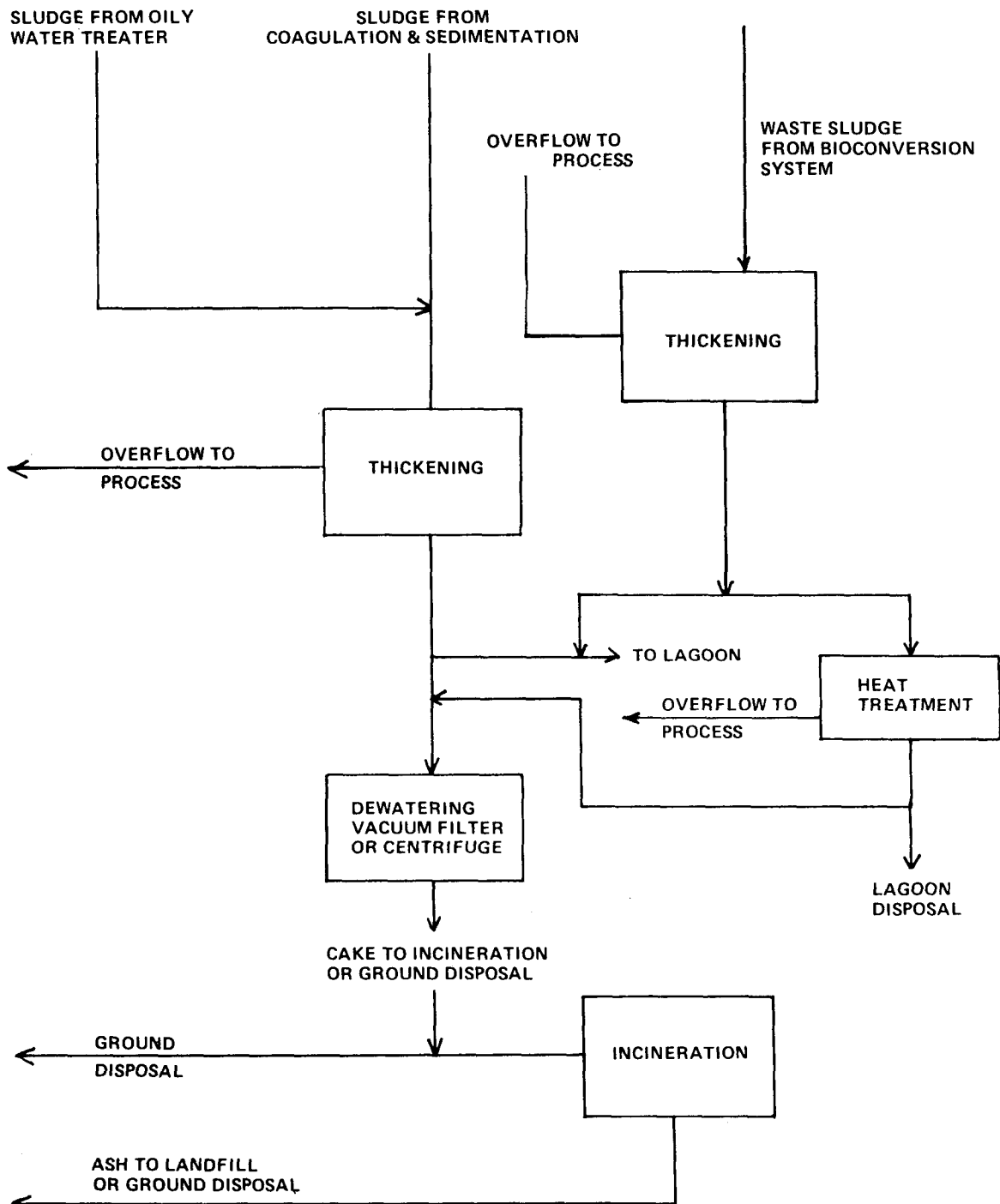

FIGURE 21

the plug flow type. Since the energy per unit/volume requirements for either option are roughly comparable, the latter procedure is generally the most cost effective means of dealing with this problem.

If carbon adsorption is to be employed instead of bioconversion, an equalized feed stream will be necessary. Regardless of other considerations, an upstream system capacitance must be provided if maximum efficiency is to be obtained from the treatment. Whenever the waste entering a coagulation and sedimentation unit tends to be highly biodegradable, troubles with gasification in high solids systems may be anticipated if neutral pH values are employed for coagulation. Therefore, it is necessary to evaluate the residence or holdup of solids that can be employed, prior to deciding upon a treatment system. Plant shutdown for turnaround or under emergency conditions, particularly if operations cease for more than two to three days, can result in a diminution in the effectiveness of bioconversion systems on startup. Under such circumstances, the advantages of having an equalization unit of substantial size ahead of the bioconversion unit become apparent. During turnaround, the equalization unit may be drained and cleaned, thereby providing the food materials necessary to sustain the resident biota in the bioconversion portion of the system. If this is not possible, provision should be made for the discharge of stored concentrated waste to the bioconversion unit during plant shutdown.

The equipment associated with the treatment steps proposed herein does not have extraordinary maintenance requirements. Normal once per year examination, along with routine maintenance, is the standard requirement. Consideration should be given to providing unit by-passes or the utilization of design concepts which will permit routine maintenance without taking the unit out of service. It should be generally possible to by-pass each individual unit without taking the plant off the line or markedly changing the over-all operational efficiency.

Waste treatment works must be well managed to avoid their becoming public nuisances. If not handled properly, lagoons, the incineration of sludge, or the regeneration of carbon may generate objectionable odors. This problem may be eliminated or controlled by proper location of the units and the use of gas emission control equipment. In the case of lagoons, proper operation of the preceding waste treatment units is essential.

#### Solid Waste Generation Associated with Treatment Technology

Depending on the precise nature of the over-all waste stream, solid waste may originate at any one of several points in the waste treatment process. Please refer to the composite waste treatment flow sheet. The principal sources of solid waste are :

1. Sludge from the under flow of a gravity type oily water treater. This sludge would normally be combined with other waste solids from the process.

2. Sludge withdrawn from the coagulation and sedimentation unit and combined with other waste sludges or processed separately.

3. Waste sludge which is normally generated in a bioconversion facility although the units can be designed to approach virtual steady state between new sludge production and the loss of resident sludge over the weir and through endogenous respiration.

Process sludges are treated by one or more of the methods outlined in Figure 21. In rough chronological order, steps leading to the ultimate disposal of sludge include the following:

1. As a first step, the sludge is thickened in a gravity thickener or a centrifugal device. In either case, effluent solid concentrations varying from 3 percent to 10 percent may be anticipated. The difference arises from the substantial differences in the characteristics of the sludges.

2. After thickening, biological sludges may be treated to reduce moisture content of the ultimate cake. The sludge is then subjected to heat and pressure to reduce the size and complexity of the protein and carbohydrate cellular material. This, in turn, releases bound water. In some cases the sludge is discharged to a lagoon after this step.

3. In the next step, the sludges are dewatered, either on a vacuum filter or in a solid bowl centrifuge. In some instances sludges will have to be conditioned with either organic polymers or inorganic polyelectrolytes prior to dewatering.

4. Following the dewatering step the sludge may be disposed of directly or incinerated for the removal of virtually all of the residual organic matter.

5. Following incineration the ash, which constitutes from 5 percent to 10 percent of the initial mass, is disposed of as land fill.

## SECTION VIII

### COST, ENERGY AND NON-WATER QUALITY ASPECTS

There are fewer than a dozen plants associated with the soap and detergent manufacturing industry which are point source dischargers into navigable waters. Of these plants, only one has a complete primary-secondary treatment plant comparable to those found in a good municipal sewage treatment system. There are several aerated and non-aerated lagoons which experience varying degrees of success in their ability to reduce the incoming load to acceptable levels.

Because of the highly variable nature of the wastes which makes individual treatment prohibitively expensive, most small and medium-size plants will continue their current practice of sending their wastes to municipal or regional systems. For this reason emphasis in this section has been placed on in-plant controls rather than end-of-pipe treatment.

#### IN-PLANT CONTROL

There are essentially three sources of in-plant contaminants of the waste water effluent streams. They are:

1. Impurities removed from raw materials
2. By-products or degradation products made in the process
3. Very dilute product (in aqueous solution) resulting from leaks and spills and the clean out of equipment.

These are discussed in the succeeding paragraphs.

TABLE 4

Range of Water Use by Process  
(gal/1000 lb Product Produced)  
(liters/119kg Product Produced)

Batch Kettle Soap	25 - 2345
Fat Splitting	203 - 23,200
Soap Via Fatty Acid Neutralization	31 - 1750
Glycerine Concentration	80 - 120,000
Glycerine Distillation	40 - 65,000
Bar Soap	9 - 2300



Oleum Sulfonation	12 - 90
Air/SO <sub>3</sub> Sulfonation	1 - 240
Chlorosulfonic Acid Sulfonation	184 - 330
Neutralization	2 - 1100
Spray Dried Detergents	14 - 228
Liquid Detergents	75 - 185
Drum Dried Detergents	265 - 400
Detergent Bars & Cakes	circa 25

### Impurities Removal

There are two main sources of impurities which concern the manufacturers of soaps and detergents. They are the light ends and color bodies in the fats and oils used in the manufacture of soap, and the light ends (usually low molecular weight fatty acids) removed in the flashing and/or distillation of fatty acid produced from the fat splitting process. In both cases the processes having high effluent loadings employ barometric condensers. Replacement of barometrics by surface condensers would appreciably reduce the amount of contamination (approximately 80 percent) and, of course, all but eliminate the entire hydraulic loading. The capital cost of this replacement would amount to approximately \$2,00-\$3,00/1000 lb annual capacity of fatty acid in a plant capable of making 100 million pounds per year having other capital cost about \$60-\$70/1000 lb of annual capacity. This, however, is not the only way in which the effluent problem could be minimized. An alternative is to install an extractive step ahead of the barometric leg where the light ends are picked up in an oil film to be later distilled for the recovery of the valuable low molecular weight acids. An installation of this type has been proven successful commercially. It has a two year payout. An initial capital investment of approximately \$7-9/1000 lb annual capacity of fatty acid produced would be required for a 20 million lb per year plant. A reduction in raw waste loadings of approximately 85 percent would be attained.

Still another method of handling the problem is the installation of a cooling tower with recirculation of condenser water, and employing a fat skimmer. A periodic blowdown of the skimmer to sewer would dispose of accumulated solubles, and the fat recovered would assist in the payout. The cost for such an installation would be approximately \$10-12/1000 lb of annual capacity for a 40 million lb per year plant. Reduction of raw waste loadings of approximately 75 percent would be anticipated. Improved performance (approximately 90% removal of both floating

and emulsified oil and grease) of skimmers can be attained at modes costs by providing chemically assisted flotation. While this will not improve removal of emulsified coconut oils, it should be borne in mind that coconut oils constitute 20% or less of the feedstocks.

Although not strictly an impurity, glycerine is carried overhead into the barometric condenser water in the process of concentrating and subsequently distilling the product out of dilute feeds. It is estimated that the cost of replacing the barometric legs with surface condensers and appropriate vacuum equipment would amount to about \$21/1000 lb annual capacity of glycerine and would reduce raw waste loads by about 90 percent. This compares with a total cost of around \$40/1000 lb annual capacity for installation of concentrators utilizing barometric condensers. The payout for the surface condenser installation (based on the additional product recovered) is around 10+ years. These estimates apply to a plant having a 10 million lb per year glycerine capacity.

Unfortunately, installation of a recirculating cooling water system would have no effect upon the effluent loadings in this case since glycerine is soluble in water in all proportions and recirculation would only result in higher concentrations in lower volumes of water. This could be offset by operating the cooling tower as a biological tower to reduce organics. Further, the reduced hydraulic load can be treated at lower costs and with greater efficiency in the typical end-of-pipe biological treatment systems.

#### By-Product/Degradation Product Control

The dark colored soap (nigre) recovered from batch kettle soap making can in some instances, constitute a disposal problem. In the larger, more integrated plants there is usually a market for the material (e.g. pet soap and industrial lubricants) so that the disposal of the material is not a total liability. Where this is not the case a modest investment would need to be made for an accumulator tank where these materials could be acidulated to break the soap, the fats being recovered and sold and the balance of the aqueous layer being sent to disposal. An investment of about \$2 - \$4/1000 lb annual capacity of soap would be needed for this operation. This is not an inconsiderable amount when related to an already fully amortized older plant, but it would result in about 75 - 80 percent reduction in raw waste load. If the fat is recovered, an ultimate payout could be realized.

Degradation of product occurs most abundantly in the sulfonation processes, particularly in the start up of an air-sulfur trioxide unit. In large integrated plants this causes only minor problems since they can often work off the relatively small amount by blending it into a large volume material. The small scale custom sulfonator is the one of concern. He has no economic alternative

but disposal to sewer. Use of a batch countercurrent process with improved agitation can give improved heat transfer as well as increased contact of reactants. This can be achieved with an almost undiscernible cost. In this case, the added capital cost would amount to about \$2.20/million kg (\$1/million lb) of annual capacity. Utilities consumption would increase less than 10 percent from utilization of a recycling loop for the neutralized sulfonic acid product stream.

#### Dilute Product From Cleanouts, Leaks & Spills

Liquid detergent manufacture at present accounts for one of the higher waste water effluent loadings in the industry. This is related to the need to clean out the mixing tanks and filling lines thoroughly when making a product change in the filling operation. If steam or air (rather than water) were used to blow the lines clean, the product could be directly reused, or in the case of steam the more concentrated solutions could be stored and either reused or disposed of more easily. The cost to the larger highly integrated plants (50 million lb per year with a capital cost of \$25-30/1000 lb of annual capacity) would amount to about \$2 - \$3/1000 lb annual capacity of anhydrous product produced. Resulting raw waste loads reduction on the order of 50 percent or greater should be realized.

Additional major sources of dilute product streams are detergent spray towers' air scrubbers and tower clean outs. A suggested way in which this could be reduced involves incorporating concentrated and dilute scrubbing streams in series to chill and scrub the exit gases from the tower. The concentrated first stage scrubber stream would be recycled to the crutcher and the dilute second stage scrubber stream used for the first stage. The capital cost would amount to about \$1.00/1000 lb annual capacity for spray towers capable of producing 100 million lb per year. This includes cooling facilities to keep the scrubber water down to an effective chilling temperature. Raw waste reduction should be approximately 65 percent.

#### END OF PIPE TREATMENT

Waste water streams from soap and detergent processes are readily biodegradable, but they do not have uniform flows nor are their concentrations constant. In most cases there are significant surges having varying strengths of contaminants. This set of conditions is very detrimental to the successful operation of a treatment system. For this reason, small scale operators having intermittent streams of 10,000 - 50,000 gallons per day of waste water are almost without alternative to utilization of municipal sewer systems.

Packaged, off the shelf units, at a cost approximating \$600/1000 gal/day, could indeed handle the load for a small plant if it were consistent in quality, concentration, and flow. None of these conditions, however, describe the waste waters associated

Table 5  
 Cost and Energy Requirements Associated  
 With Various Treatment Methods

Treatment Procedure	Costs		Power Requirements
	Capital	Operational	
<u>Oil &amp; Grease Removal</u>			
Hand skimmed tanks	\$26-79/1000 1 (\$100-300/1000 gal.)	\$5.00/day	None
Mechanically cleaned tanks	\$13-18/1000 1 (\$50-70/1000 gal.)	\$0.008-0.026/1000 1 (\$0.03-0.10/1000 gal.)	0.19-0.57 kw/1000 cu m/day 1-3 hp mgd
Mixed media filtration	\$21-66/1000 1 (\$80-250/1000 gal.)	\$0.032-0.105/1000 1 (0.12-0.25/1000 gal.)	1.52-2.85 kw/1000 cu m/day 8-15 hp/mgd
Flotation	\$11-37/1000 1 (\$40-140/1000 gal.)	\$0.03-0.11/1000 1 (\$0.12-0.40/1000 gal.)	1.14-2.85 kw/1000 cu m/day 6-15 hp/mgd
Carbon adsorption	\$26-210/1000 1 (\$100-800/1000 gal.)	\$0.22-0.66/kg oil (\$0.10-0.30/lb oil)	0.95-1.9 kw/1000 cu m/day 5-10 hp/mgd

Table 5 (cont'd)

Treatment Procedure	Costs		Power Requirements
	Capital	Operational	
<u>Carbon Adsorption System</u>			
Fixed carbon in column	\$26-79/1000 1 (\$100-300/1000 gal.)	\$0.04-0.132/1000 1 (\$0.15-0.50/1000 gal.)	0.95-1.9 kw/1000 cu m/day 5-10 hp/mgd
Powdered carbon fed prior to coagulation & sedimentation void	\$6-26/1000 1 (\$25-100/1000 gal.)	\$0.04-0.132/1000 1 (\$0.15-0.50/1000 gal.)	0.95-2.85 kw/1000 cu m/day 5-15 hp/mgd
<u>Final Clarification</u>	\$13-40/1000 1 (\$50-150/1000 gal.)	\$0.008-0.019/1000 1 (\$0.03-0.07/1000 gal.)	0.19-0.57 kw/1000 cu m/day 1-3 hp/mgd
<u>Effluent Filtration</u>	\$21-69/1000 1 (\$80-260/1000 gal.)	\$0.013-0.040/1000 1 (\$0.05-0.15/1000 gal.)	0.95-1.9 kw/1000 cu m/day 5-10hp/mgd
<u>Reverse Osmosis Systems</u>	\$79-158/1000 1 (\$300-600/1000 gal.)	\$0.079-0.269/1000 1 (\$0.30-1.00/1000 gal.)	190 kw/1000 cu m/day 1000 hp/mgd

Table 5 (cont'd)

Treatment Procedure	Costs		Power Requirements
	Capital	Operational	
<u>Suspended Solids Removal</u>			
Coagulation & sedimentation	\$13-40/1000 1 (\$50-150/1000 gal.)	\$0.013-0.024/1000 1 (\$0.05-0.09/1000 gal.)	0.19-0.57 kw/cu m/day 1-3 hp/mgd
Chemical addition		\$0.003-0.013/1000 1 (\$0.01-0.05/1000 gal.)	Fractional mgd
Mixed Media	Filtration & Flotation - See Oil & Grease Removal		
<u>Bioconversion Systems</u>			
Activated sludge	\$29-73/1000 1 (\$110-275/1000 gal.)	\$0.013-0.039/1000 1 (\$0.05-0.15/1000 gal.)	19-95 kw/1000 cu m/day 100-500 hp/mgd
Aerated Lagoons	\$28-53/1000 1 (\$70-2000/1000 gal.)	\$0.016-0.029/1000 1 (\$0.04-0.12/1000 gal.)	19-95 kw/1000 cu m/day 100-500 hp/mgd
Extended aeration	\$21-79/1000 1 (\$80-300/1000 gal.)	\$0.013-0.053/1000 1 (\$0.05-0.20/1000 gal.)	19-95 kw/1000 cu m/day 100-500 hp/mgd

111

Table 5 (cont'd)

- Power cost taken at \$0.01 KWH
- Attendance @ \$5.00/hour
- Manufacturer data used for power requirements
- Plant sizes are generally across 0.01-0.19 kw/1000 cu m/day (0.1-1.0 MGD) to show cost variation and economy of scale.

with operations of the conventional small or large plant. An alternative could be the installation of a large equalization basin, but it would be prohibitively expensive for a small operation. Further, the typical plant is usually located in a metropolitan area where the availability of enough land poses an insurmountable problem.

In plants having daily flows of about 500,000 gallons, the capital cost for end of the pipe treatment can be expected to run around \$2,000,000 with an operating cost approaching \$900/million gallons. Best practicable control treatment currently available would most likely include chemical precipitation and equalization followed by an activated sludge unit and final clarification. A viable alternative for small plants is an aerated lagoon. Such lagoons should have 40-50 hp aeration per million gallons capacity and some provision for clarification of the final effluent with return of the sludge to the lagoon.

Best available technology economically achievable would incorporate a final polishing operation, such as mixed media filtration or carbon absorption, or a second stage activated sludge unit with plug flow operation. Incorporation of such polishing steps should result in at least 50-75% reduction of pollutants contained in the effluent from the biological treatment and reduce variability in the quality of discharge.

#### ENERGY REQUIREMENTS

With the introduction of surface condensers to replace the barometrics, utility costs (including power) will increase. Generally, in those processes requiring capital modification because of guideline recommendations, the utility costs will rise an average 22¢/1000 lb of product manufactured. About 7¢ of this is due to direct power needs, the rest being for steam, cooling water, etc.

As might be expected, the processes impacted the most are glycerine concentration and distillation which amounts to about \$7.80/1000 lb.

#### NON-WATER QUALITY ASPECTS

There is very little non-waterborne waste generated in the production of soaps and detergents. Almost all (99+ percent) of the raw materials entering the soap and detergent processes end up as packaged products for sale to the household or industrial consumer. Modest amounts of solid wastes end up in sanitary landfill operations.

In the operation of dry filling lines there are infrequent problems with the mechanical equipment that result in damaged cartons. This same problem applies with many of the operations, including warehousing. Wherever possible, the product is recycled back into the manufacturing process unless it becomes



excessively contaminated. At most, one would expect several hundred pounds per day of solid wastes being sent to a sanitary landfill for disposal from a large plant.

During spray drying tower cleanouts, there often will be caked, charred material unsuitable for recycle. This would amount to about 1000 lb per week from a very large plant; again, this material would be sent to a sanitary landfill.

Sludge from waste water treatment will also be an input into sanitary landfill operations. One system in operation pumps the sludge from the biotreater into the chemical treater where it precipitates with the addition of lime. The settled precipitate is pumped to a settling basin where the sludge builds up to a depth worthy of disposal, whereupon the "solids" are then taken to the landfill.

Conversion of air contamination problems into waste water problems is on the increase in the soap and detergent industry. Soap dust from bar soap manufacture, and fines in exit air from the detergent spray tower are being dissolved in scrubber water to be ultimately treated in sewage systems. This is an ideal way to maximize the disposal alternatives. The products are biodegradable and readily handled in already existent standard treatment facilities.

#### IMPLEMENTATION OF TREATMENT PLANS

The equipment required for implementing the waste treatments discussed in the preceding sections of this report are available as off-the-shelf items or they may be found in manufacturers' catalogs. In the present economy the construction manpower is generally available, although short term local variations in availability are to be expected. However, virtually all of the work required would be carried out by the general contractor normally involved in the construction of sewage and industrial waste treatment works.

Depending upon the waste treatment employed and the precise unit process under consideration, the land requirements will vary from as little as one-half acre to as much as three or four acres. It is likely that, for the industry as a whole, a good mean land requirement would be of the order of 0.4 to 0.8 ha (one to two acres).

The basic costs and relative efficiencies of the waste treatment processes outlined in the composite waste treatment flow chart have been summarized in Table 5. The capital and operating costs were derived from actual plants which have been constructed within the past few years. The higher range costs and capital are applicable to waste water flows of 50,000 - 100,000 gallons per day. The lower end of the range is applicable to volumes of 2 - 3 million gallons per day. The data in the table were adjusted upward and expressed in terms of 1972 dollars.

Regarding operational costs, the figures cited are direct costs only. They do not include any administrative, overhead, fringe benefits or directly charged laboratory support. If these costs were to be included, the total would be roughly double.

Sludge conditioning and disposal costs are highly variable, depending upon the nature of the sludge and the procedures followed. The cost brackets for the sequences outlined in Figure 20 are shown in Table 6. It is assumed that land is available for lagoon and landfill disposal of sludge and ash.

Table 6

## Cost of Sludge Conditioning and Disposal Operations

Procedure	Costs		Power Requirements
	Capital	Operational	
1. Thickening-influent at 5000 mg	\$1800-6400/metric ton (\$2000-7000/ton)	\$1.60-6.40/metric ton (\$1.80-7.00/ton)	Fractional/tpd
2. Lagooning	Depends upon land cost entirely		
3. Heat Treatment	\$13,640-45,400/metric ton (\$15,000-50,000/ton)	\$4.50-13.60/metric ton (\$5-15/ton)	181-454 hp/mtpd 200-500 hp/tpd
Dewatering			
4. Vacuum Filtration	\$103-297/m <sup>2</sup> (95-275/sq ft)	\$7.30-31.80/metric ton (\$8-35/ton)	22.7-68.2 hp/mtpd 22-75 hp/tpd
5. Centrifugation	\$455-909/mtpd (\$500-1000/tpd)	\$4.55-22.70/metric ton (\$5-25/ton)	45.5-90.9 hp/mtpd 50-100 hp/tpd
6. Incineration	\$136,400-681,800/mtpd (\$150,000-750,000/tpd)	\$4.55-22.70/metric ton (\$15-50/ton)	182-273 hp/mtpd 200-300 hp/tpd  17.2-68.9 l of fuel oil/metric ton (5-20 gal. fuel oil/ton)

SECTION IX  
BEST PRACTICABLE CONTROL TECHNOLOGY  
CURRENTLY AVAILABLE

Introduction

One of the first steps in the development of guidelines was the determination of raw waste loadings in the waste water flows for each subcategory in terms of kg/kg (lb of pollutant/1000 lb) of anhydrous product produced in that subcategory. The raw waste loading to be expected from the best practicable technology was established and the guidelines values defined as appropriate reduction of the raw waste load, e.g., reasonable expectancy of any treatment plant having a biological secondary treatment process to attain 90 percent reduction of BOD<sub>5</sub>.

Wherever appropriate, attention was given to in-plant controls to minimize the raw waste load. Thus, best practicable control technology may be defined as good current in-plant control followed by an end-of-pipe system consisting of adequate equalization, efficient biological treatment (e.g., extended aeration) and final clarification.

For several soap and detergent processes a negligible discharge has been achieved by most manufacturing plants. Best practicable control technology currently available guidelines give each of these processes a very small but finite effluent allowance because of one or more of the following reasons:

1. The product in the effluent stream is so degraded it would be unsuitable for incorporation in the final product and must thus be disposed of.
2. The waste water source is so dilute as to require undue amounts of heat energy to recover the dissolved solids content.
3. The material in the waste water is quite biodegradable; therefore, it is readily handled by the receiving treatment plant.

In those categories where the guidelines have been set particularly low, the permit writer should be alert to the occasional need to make spot increases in these limits. Upsets and mechanical problems requiring cleanouts may crop up, rare though they may be. This will be particularly critical for small plants (under \$500,000 in gross proceeds). The larger integrated plants have sufficient flexibility in their ability to recycle the contents of waste streams to minimize their need for spot increases.

In a few processes there are some relatively heavy discharges of salt and sodium sulfate. No limit has been established for these very low toxicity materials since (1) they will be highly diluted by other process effluents before becoming a point discharge and (2) the permit writer will undoubtedly want to evaluate the

background levels in the receiving waters and determine what levels, if any, should be established.

No maximum delta temperature was established since the differential between inlet and outlet process water temperatures is quite modest, at most around 17°C (30°F), and much of the heat would be dissipated in the waste treatment process.

The interrelationship of air and water pollution problems became quite apparent in this study. Increasingly stringent air emission standards have set performance requirements beyond the ability of dry recovery systems available on detergent spray towers. Wet scrubbers have been employed which now allow the air effluent to meet those standards, but result in a substantial water flow and a correspondingly higher water pollutant loading.

In every instance in the following guidelines, the pH of the point source discharge is required to be between 6.0 and 9.0. With but few exceptions this requirement will be met by the mingling of individual raw waste streams in the treatment facilities and will not require special pH adjustment.

SOAP MANUFACTURING

101 - SOAP MANUFACTURE BY KETTLE BOILING

General

This ancient art has been carefully scrutinized by all of its practitioners to minimize cost and the avoidable loss of marketable products where the installed capital permits. Even in the area of very high quality soaps there still appears to be a preference for this well established process.

There are essentially two main streams carrying away waste from this source (in actual practice there may be more subsidiary sources). They are typified by the blocks indicated in the simplified flow diagram given below:

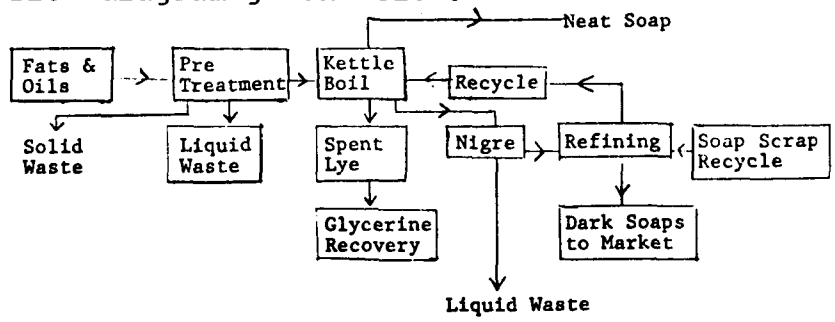

WASTEWATER SOURCES IN SOAP MANUFACTURE

FIGURE 22

The liquid waste from fat pretreatment will normally be a fat in water emulsion of modest BOD<sub>5</sub>, with perhaps some clay and other organics. However, the stream from nigre processing, often just a purge, will be very rich in BOD<sub>5</sub> and contain some sodium chloride and sodium sulfate. Some soap manufacturers do not, at present, completely process their nigre but run it directly to sewer. This is a point, for some, to improve in effluent control.

#### Raw Waste Loading

The following are the expected thirty day average raw waste loadings which would be entering a waste treatment plant:

BOD<sub>5</sub> - 6 kg /kkg (6 lb/1000 lb) anhydrous soap  
COD - 10 kg /kkg (10 lb/1000 lb) anhydrous soap  
Suspended Solids - 4 kg /kkg (4 lb/1000 lb) anhydrous soap  
Oil and Grease - 0.9 kg /kkg (0.9 lb/1000 lb) anhydrous soap

#### Best Practicable Control Technology Currently Available Guidelines

On a thirty day average basis the following parameter values are recommended:

BOD<sub>5</sub> - 0.60 kg/kkg (0.60 lb/1000 lb) anhydrous soap  
COD - 1.50 kg/kkg (1.50 lb/1000 lb) anhydrous soap  
Suspended Solids - 0.40 kg/kkg (0.40 lb/1000 lb) anhydrous soap  
Oil and Grease - 0.10 kg/kkg (0.10 lb/1000 lb) anhydrous soap

pH 6.0 - 9.0

In the event of upset in either process or treatment, startup or shutdown procedure, a value of three times that indicated above should be considered, provided that over any given thirty day period the recommended average is maintained.

#### Best Practicable Control Technology Currently Available

In many soap plants there are no access points in the floor to the sewer. This makes good housekeeping unavoidable. All leaks and spills are promptly attended to and recycled within the process.

The guidelines limitations can be attained by the production (and marketing) of low grade soap from the nigre, recovery of fats from acidulated sewer lyes and nigre, and secondary (biological) treatment of the resulting waste.

### Rationale and Assumptions

Fat saponification is carried out counter-currently where the aqueous caustic stream is exhausted in a final reaction with fresh fat. At the other end of the process the nearly fully saponified fat is completely reacted by coming into contact with fresh caustic. Salt recycle becomes automatic in that energy required to concentrate the glycerine stream automatically concentrates the salt. Filtration of the evaporator product provides the recycle salt. There is still a substantial amount of salt that goes to the sewer via the bleed of the nigre.

Phase relationships of electrolyte, soap and caustic content largely govern their concentration and use to maintain proper soap solubility. Within these constraints good manufacturing management will minimize the total constituents going to sewer.

At present, this process can be brought close to no discharge only at the expense of the smaller soap manufacturers who do not exhaust their nigre. The recommended settling and acidulation tank will go a long way toward attaining this goal.

Most kettle boil soap making equipment is several decades old and represents fully amortized capital. The soap market is not noted for its dynamic expansion.

### 102 - FATTY ACID MANUFACTURE BY FAT SPLITTING

#### General

The waste water effluents for disposal come from essentially three sources; pretreatment of the fat, light ends emitted from the fat splitter and the fat still, and the water solubles left in the acidulated still bottoms after the recycleable fats are removed and recovered.

The light ends mentioned above are found in the condensate from the barometric condenser and include short chain fatty acids and unsaponifiables. One of the minor contaminants in the stream coming from the still bottoms is the catalyst. It can be the sulfate salt of zinc, or other alkaline earth metals.

A simplified schematic is given for the process to indicate the approximate location of waste water streams.

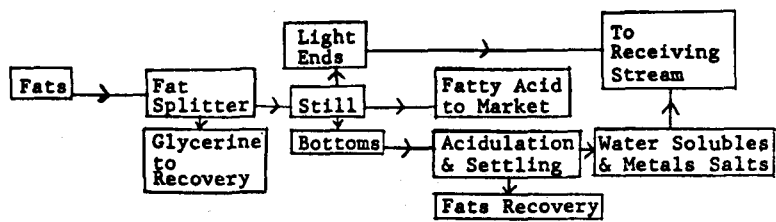

**FAT SPLITTING**

**FIGURE 23**



The following raw waste loading can be expected:

BOD<sub>5</sub> - 12 kg /kkg (12 lb/1000 lb) anhydrous acid

COD - 22 kg /kkg (22 lb/1000 lb) anhydrous acid

Suspended Solids - 22 kg /kkg (22 lb/1000 lb) anhydrous  
acid

Oil and Grease - 2.5 kg /kkg (22 lb/1000 lb) anhydrous  
acid

Included in this loading are waste water flows from: fats treatment, fats splitting, fatty acid distillation and still bottoms disposal.

#### Best Practicable Control Technology Currently Available Guidelines

On a thirty day average, the following parameter levels are recommended:

BOD<sub>5</sub> - 1.20 kg/kkg (1.20 lb/1000 lb) anhydrous acid

COD - 3.30 kg/kkg (3.30 lb/1000 lb) anhydrous acid

Suspended Solids - 2.20 kg / kkg (2.20 lb/1000 lb)  
anhydrous acid

Oil and Grease - 0.30 kg/1000 lg (0.30 lb/1000 lb) anhydrous  
acid

pH 6.0 - 9.0

No additional provision need be made for startup, shutdown or upsets. Allowance should be made for a threefold increase to account for variability of treatment over a 24 hour period, providing that during a thirty day period, which includes this day of high loading, the recommended average is maintained.

#### Best Practicable Control Technology Currently Available

Essential to the proper performance of the plant is the incorporation of appropriate fat traps. Indicative of the technology involved is the flow chart of a condenser/recovery unit which could handle the load. Note that the only effluent is blowdown of the fat settler which handles cooling tower waters.

Due to the high temperatures maintained in the fat splitter, fat solubility and reaction rate are high so that 99 percent hydrolysis can be expected. This makes separation of the condensates a relatively simple problem, well within the engineering capabilities of the industry. As noted in the above discussion,

it is reasonable to expect that the only materials to be disposed of are light ends and bottoms.

### Rationale and Assumptions

A fats recovery unit for treating fatty acid still bottoms will help minimize loadings of effluent. This equipment plus biological secondary treatment will bring the loadings down to the guidelines level.

## 102 - FATTY ACID HYDROGENATION

### General

As an example of the depth to which some technological studies have been conducted, the details of fatty acid hydrogenation processing are presented. Due to the advanced state of the art, guidelines recommended are to cover all levels.

### Technology for All Levels

Hydrogenation of fatty acids intended for soap manufacture is regarded as an additive effluent loading to the fat splitting operation.

The principal raw materials for the manufacture of fatty acids used in soap making are coco and tallow fats. These are generally used in the ratio of about 80 percent tallow fatty acids to 20 percent coco fatty acids in soap making.

This blend contains in the order of 15 percent of the mono-unsaturated oleic acid and around 3 - 4 percent of the doubly unsaturated linoleic acid. There is very little of the triply unsaturated linolenic acid. Twenty percent unsaturated fatty acids in soap is often excessive, consequently the tallow portion of the fatty acids going into soap manufacture are partially hydrogenated. This is particularly necessary since tallow contains up to 50 percent oleic acid esters and as much as 3 percent linoleic esters.

The usual process of making fatty acids and the hydrogenation of them is given in the schematic flow diagram for the fatty acid manufacture subcategory. The hydrogenation process is usually carried out batch wise, particularly for fatty acids destined for soap making.

The hydrogen source for this process depends upon plant location. When near a petroleum refinery the hydrogen is often available from cracking operations and subsequently requires purification. Hydrogen is also available from electrolytic cells dedicated to electrolysis of salt for production of sodium and chlorine.

Another common source of hydrogen is that from the dehydrogenation of isopropyl alcohol to make acetone. Whatever the

source of hydrogen there will usually be some alkane impurities that will build up in the recycle use of hydrogen; consequently, a bleed is necessary and is usually disposed of by burning. This disposition carries no water effluent and consequently is disregarded in the guidelines.

The hydrogenation process requires a catalyst. There are two well-known catalyst systems. One involves the deposition of nickel as nickel formate onto a pumice or kieselguhr or a synthetic product such as Celite. The other commonly used catalyst is Raney-nickel. Both catalysts are usually suspended in the liquid to be hydrogenated and subsequently filtered out. When Raney-nickel is used, the spent catalyst is often recovered and returned to the manufacturer for reprocessing.

Complete saturation of the fatty acids is not desirable since a modest amount of cross linking by oxidation helps to make a firm soap and gives the bar good feel or hand. Though not strictly true, the hydrogenation of coco and tallow fatty acids is described as if the same in nature.

Hydrogenation is usually carried out with the catalyst suspended in the liquid fatty acids in a batch process heated to a temperature of approximately 175 - 200 C (347 - 392 F) as the hydrogen passes through the reactor. When the degree of saturation desired is achieved (as measured by iodine number) the reaction is terminated. Recovered hydrogen is removed and sent back to storage via a booster system.

During the hydrogenation process a number of side reactions occur, some of which cause significant waste water effluent contamination. Isomerization of the double bond along the chain does not cause any difficulty. However, occasional chain scission occurs, resulting in the formation of short chain length olefins and short chain fatty acids not desirable in the soap making process. As a result of the fatty acid pre-heating prior to hydrogenation there is a tendency for some oxidative cross linking to occur, resulting in a modest amount of polymerized fatty acids. Storage of the fatty acids at high temperatures also accelerates this polymerization reaction. Some of these undesirable reactions result in added waste water contamination.

The same raw waste loadings can be expected for all levels of technology.

#### Raw Waste Loadings - All Levels

The following raw waste loadings are expected:

BOD<sub>5</sub> - 1.5 kg/kkg (1.5 lb/1000 lb) anhydrous acid

COD - 2.5 kg/kkg (2.5 lb/1000 lb) anhydrous acid

Suspended Solids - 1.0 kg/kkg (1.0 lb/1000 lb)

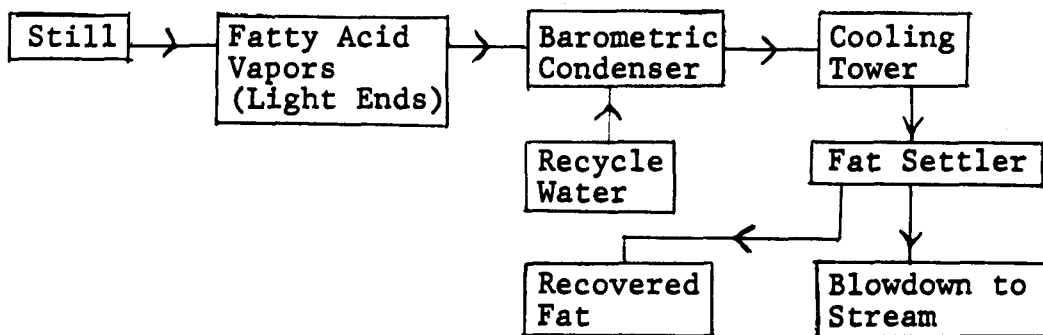

FATS RECOVERY SYSTEM

FIGURE 24

anhydrous acid

Oil and Grease- 1.0 kg/kg (1.0 lb/1000 lb)  
anhydrous acid

On a thirty day average basis, the following guidelines are recommended:

BOD<sub>5</sub> - 0.15 kg/kg (0.15 lb/1000 lb) anhydrous acid

COD - 0.25 kg/kg (0.37 lb/1000 lb) anhydrous acid

Suspended Solids - 0.10 kg/kg (0.10 lb/1000 lb)  
anhydrous acid

Oil and Grease - 0.10 kg/kg (0.10 lb/1000 lb)  
anhydrous acid

pH - 6.0 - 9.0

There is little or no need for an upset allowance in addition to that to account for variability of treatment.

#### Rationale and Assumptions

It may be noted that hydrogenation steps in the manufacture of fatty acids from fats is considered as a supplemental allowance in view of the occasional use of this process in the general manufacturing system for soap manufacture. The levels of effluents suggested and their nature have been outlined above, based upon a reasonable allowance by careful practice of the art of hydrogenation and by a careful control and maximum recovery of effluent streams. There is no particular discernible addition in the way of capital requirements or utility and power requirements that would be more than marginal for these effluent limitations guidelines requirements.

#### 103 - SOAP FROM FATTY ACID NEUTRALIZATION

##### General

This method of neat soap manufacture is a clean process. The major starting material, fatty acid, has already been subjected to a severe refining step. During the oil splitting process the volatile acids and color bodies have been removed.

Neutralization is frequently carried out with soda ash, which results in the evolution of carbon dioxide. In large installations, the neutralization may be a continuous process. Batch operations utilizing stoichiometric amounts of fatty acids and alkalis may be employed.

### Raw Waste Loading

The following raw waste loading can be expected:

BOD<sub>5</sub> - 0.1 kg /kgg (0.1 lb/1000 lb) anhydrous soap

COD - 0.25 kg /kgg (0.25 lb/1000 lb) anhydrous soap

Suspended Solids - 0.2 kg /kgg (0.2 lb/1000 lb)  
anhydrous soap

Oil and Grease - 0.05 kg /kgg (0.05 lb/1000 lb)  
anhydrous soap

### Best Practicable Control Technology Currently Available Guidelines

On a thirty day average basis the following parameter limits are recommended:

BOD<sub>5</sub> - 0.01 kg /kgg (0.01 lb/1000 lb) anhydrous soap

COD - 0.05 kg/kkg (0.05 lb/1000 lb) anhydrous soap

Suspended Solids - 0.02 kg /kgg (0.02 lgs/1000 lb)  
anhydrous soap

Oil and Grease - 0.01 kg / kkg (0.01 lb/1000 lb)  
anhydrous soap

pH 6.0 - 9.0

There is little or no need for an additional upset allowance.

### Best Practicable Control Technology Currently Available

Secondary biological treatment will very adequately handle the effluent from this process.

### Rationale and Assumptions

This process is carried out using stoichiometric quantities of all reactants so that the entire content of the reactor is sent in total to the next processing step; bar soap, soap flakes/chips, or liquid soap. The product is neat soap at approximately 70 percent concentration.

Leaks from pump and other packing glands should be gathered and returned to the process.

### 104 - GLYCERINE RECOVERY

## General

The character of the waste water streams from glycerine recovery will be determined by the source of the dilute streams which are concentrated. There are two sources of dilute glycerine; one from the processing of sweet water lyes of kettle boiling soap and the other from fat splitting.

In the case of the soap making source, a stream which contains 8 - 15 percent glycerine, salt and miscellaneous organic matter is run to a batch evaporator and concentrated to 60 - 80 percent. In glycerine concentration the 80 percent product is removed as a bottoms product and therefore contains all of the original impurities (less a lot of the original salt), but in a much more concentrated form. At this point the stream is either sold to a glycerine refiner or again batch handled in a glycerine still where the product is taken overhead.

The dilute glycerine stream from fat splitting can be varied significantly in concentration. It all depends upon how the fat splitter is operated. Glycerine is a bottoms product from the splitter. A fairly concentrated glycerine can be obtained if the yield of fatty acid is sacrificed or the production rate is diminished.

As the glycerine stream comes from the fat splitter, it is normally flashed to atmospheric pressure, thereby gaining an immediately increased concentration of product.

A simplified flow chart of the concentrating and distillation process is as follows:

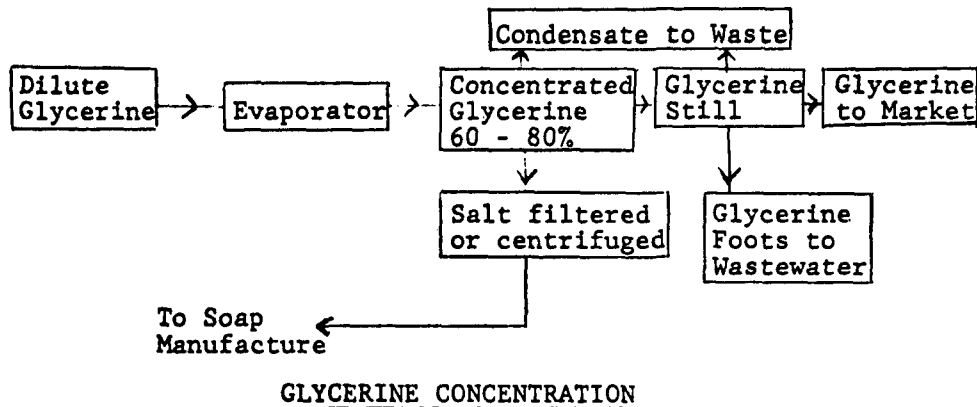

FIGURE 25

## Raw Waste Loading

The glycerine concentration and glycerine distillation should be handled separately. Quite often the glycerine which is

concentrated to 60 or 80 percent is sold to another firm for further distillation to an assay of 98+ percent glycerine.

Raw waste characteristics are expected to average as follows:

Glycerine Concentration

BOD<sub>5</sub> - 15 kg /kkg (15 lb/1000 lb) anhydrous glycerine

COD - 30 kg /kkg (30 lb/1000 lb) anhydrous glycerine

Suspended Solids - 2 kg /kkg (2 lb/1000 lb) anhydrous glycerine

Oil and Grease - 1 kg/kkg (1 lb/1000 lb) anhydrous glycerine

Glycerine Distillation

BOD<sub>5</sub> - 5 kg /kkg (5 lb/1000 lb) anhydrous glycerine

COD - 10 kg /kkg (10 lb/1000 lb) anhydrous glycerine

Suspended Solids - 2 kg /kkg (2 lb/1000 lb) anhydrous glycerine

Oil and Grease - 1 kg/kkg (1 lb/1000 lb) anhydrous glycerine

Best Practicable Control Technology Currently Available Guidelines

Separate guidelines should be established for the waste water effluents for the glycerine concentration step and the final glycerine distillation since, in many cases, these two operations are not carried out at the same geographical location nor by the same manufacturer. In the event both concentration and distillation are conducted at the same location, the parameter values of each operation should be combined for a final effluent allowance.

On a thirty day average basis, the following effluent guidelines are recommended:

Glycerine Concentration

BOD<sub>5</sub> - 1.50 kg /kkg (1.50 lb/1000 lb) anhydrous glycerine

COD - 4.50 kg/1000 lg (4.50 lb/1000 lb) anhydrous glycerine

Suspended Solids - 0.20 kg/kkg (0.20 lb/1000 lb) anhydrous glycerine

Oil and Grease - 0.10 kg /kkg (0.10 lb/1000 lb) anhydrous glycerine



pH 6.0 - 9.0

Glycerine Distillation

BOD<sub>5</sub> - 0.50 kg /kgg (0.50 lb/1000 lb) anhydrous glycerine

COD - 1.50 kg /kgg (1.50 lb/1000 lb) anhydrous glycerine

Suspended Solids - 0.20 kg / kkg (0.20 lb/1000 lb)  
anhydrous glycerine

Oil and Grease - 0.10 kg /kkg (0.10 lb/1000 lb) anhydrous  
glycerine

pH 6.0 - 9.0

Little or no upset allowance is justifiable and it should not affect the thirty day average for either glycerine concentration or distillation. Therefore, the allowance for variability of treatment is sufficient to cover these subcategories.

Best Practicable Control Technology Currently Available

Much of the glycerine concentrating equipment in soap plants is fairly old. It is operated in a batch manner and apparently the vapors carry a fair amount of entrainment, as is evidenced by the amount of salt carryover in the condensate. The long residence time in the concentrators helps to build up glycerine polymers and degrades other heavy ends leading to high BOD<sub>5</sub> loadings in the resulting waste water stream.

Where the barometric condenser is continued in use, the installation of a biological cooling tower with the attendant recycle of barometric water can materially reduce the raw waste load.

Rationale and Assumption

In almost all cases observed there has been a significant BOD<sub>5</sub> loading in the barometric condenser water, which is due to the glycerine escaping the condensing system. Apparently this is not now regarded as a worrisome economic loss; it does constitute a high biochemical loading. The employment of more efficient condensers, eliminating the barometric leg, is one way in which effluent loadings can be reduced. Another method is the employment of column reflux in the glycerine evaporators to reduce glycerine loss.

105 - SOAP FLAKES AND POWDERS

General

Neat soap is either chill roll, air or spray dried. In either case, the waste water loading is minimal. There are occasional washdowns and cleanups required, though rare.

#### Raw Waste Loading

The leaks, spills and pump gland cooling water will contribute the following loadings:

BOD<sub>5</sub> - 0.1 kg /kkg (0.1 lb/1000 lb) anhydrous soap

COD - 0.3 kg /kkg (0.3 lb/1000 lb) anhydrous soap

Suspended Solids - 0.1 kg /kkg (0.1 lb/1000 lb)  
anhydrous soap

Oil and Grease - 0.1 kg /kkg (0.1 lb/1000 lb)  
anhydrous soap

#### Best Practicable Control Technology Currently Available Guidelines

On a thirty day average basis, the parameter levels are recommended to be:

BOD<sub>5</sub> - 0.01 kg /kkg (0.01 lb/1000 lb) anhydrous soap

COD - 0.05 kg /kkg (0.05 lb/1000 lb) anhydrous soap

Suspended Solids - 0.01 kg /kkg (0.01 lb/1000 lb) anhydrous soap

Oil and Grease - 0.01 kg /kkg (0.01 lb/1000 lb) anhydrous soap

pH 6.0 - 9.0

The permit authority may find an occasional situation meriting a spot increase above these values for unforeseen equipment washouts in addition to the allowance for treatment variation.

#### Best Practicable Control Technology Currently Available

Manufacture of flakes and powders has been optimized well to minimize losses. The systems are maintained dry in normal practice, thereby no continuous waste water is generated. Only where there is associated soap reboil (to recover scrap soap) is there any appreciable amount of effluent generated.

Incineration of scrap soap is one way in which effluents could be reduced, where applicable and economically feasible. In any event, biological secondary treatment will appropriately reduce the waste loadings to acceptable levels.

#### 106 - BAR SOAPS

## General

Starting with neat soap (approximately 70 percent soap solution in water) the processes for making bar soaps are quite varied. The major differences occur in the drying technique. Soaps in bar form will have a final moisture content varying from 8 percent to over 15 percent, depending upon the particular properties desired.

Depending upon the particular products made and processes employed, situations encountered range from those with no waste water effluents of any kind generated to those having several scrubber water effluents. Washouts may be a minor source of pollution, both in terms of effluent volume and pollutant loadings.

## Raw Waste Loading

The following waste water effluent concentrations are regarded as an average expectation:

BOD<sub>5</sub> - 3.4 kg /kkg (3.4 lb/1000 lb) anhydrous soap

COD - 5.7 kg /kkg (5.7 lb/1000 lb) anhydrous soap

Suspended Solids - 5.8 kg/kkg (5.8 lb/1000 lb) anhydrous soap

Oil and Grease - 0.4 kg/kkg (0.4 lb/1000 lb) anhydrous soap.

## Best Practicable Control Technology Currently Available Guidelines

On a thirty day average basis the following parameter values are recommended:

BOD<sub>5</sub> - 0.34 kg/kkg (0.34 lb/1000 lb) anhydrous soap

COD - 0.85 kg/kkg (0.85 lb/1000 lb) anhydrous soap

Suspended Solids - 0.58 kg/kkg (0.58 lb/1000 lb)  
anhydrous soap

Oil and Grease - 0.04 kg/kkg (0.04 lb/1000 lb) anhydrous soap

pH 6.0 - 9.0

Little or no allowance for upset is required.

## Best Practicable Control Technology Currently Available

There is concerted effort within the industry to minimize water use in this particular operation. One of the unresolved questions is whether air quality restrictions will force other "dry" operators to incorporate scrubber systems for picking up elusive soap dust.

The levels specified in the guidelines are readily achievable by the collection and recycle of soap dust (via dust collectors or scrubbers) or by secondary biological treatment.

### Rationale and Assumptions

Without much more detailed analysis of the bar soap making operation it is very difficult to discern just how close to zero discharge all processes could come without seriously jeopardizing the product performance, hence the relatively broad allowances.

### 107 - LIQUID SOAP

#### General

Neat soap (approximately 70 percent soap and 30 percent water) is run into a mixing tank to be blended with other ingredients, filtered if required, and drummed. There may be need for an occasional equipment washout and a frequent filter cleanout.

Constituents going into these blends are quite varied since their functions range widely. This kind of business is close to custom blending due to the high performance nature of many of their products.

#### Raw Waste Loading

On the basis of a thirty day average the following raw waste loadings can be expected:

BOD<sub>5</sub> - 0.1 kg/kkg (0.1 lb/1000 lb) anhydrous soap

COD - 0.3 kg/kkg (0.3 lb/1000 lb) anhydrous soap

Suspended Solids - 0.1 kg/kkg (0.1 lb/1000 lb) anhydrous soap

Oil and Grease - 0.1 kg/kkg (0.1 lb/1000 lb) anhydrous soap

#### Best Practicable Control Technology Currently Available Guidelines

As a thirty day average the following effluent parameter values are recommended:

BOD<sub>5</sub> - 0.01 kg/kkg (0.01 lb/1000 lb) anhydrous soap

COD - 0.05 kg/kkg (0.05 ;bs/1000 lb) anhydrous soap

Suspended Solids - 0.01 kg/kkg (0.01 lb/1000 lb) anhydrous soap

Oil and Grease - 0.01 kg/kkg (0.01 lb/1000 lb) anhydrous soap

pH 6.0 - 9.0

There may be an occasional need on the part of some manufacturers to exceed these limits due to a highly varied product mix requiring washouts more frequently than allowed above.

#### Best Practicable Control Technology Currently Available

Secondary biological treatment is adequate to meet the levels proposed.

#### Rationale and Assumptions

This processing step is essentially clean, requiring only rare washouts to prevent cross contamination of widely varied performance products. Many of these same processors blend dry detergents requiring comparable frequency of washouts. A biological secondary treatment is expected to be adequate to handle the effluents.

#### 201 - OLEUM SULFONATION/SULFATION

##### General

This chemical process has been optimized in that it is close to a "push button" operation. It is practically troublefree and requires washdowns only when there is to be maintenance of the operating equipment. The leaking pump glands are a problem typical of this kind of equipment, but modest in nature. Normally an operator can quickly observe a significant leak and repair it promptly.

##### Raw Waste Loading

An average expected raw waste loading is:

BOD<sub>5</sub> - 0.2 kg/kkg (0.2 lb/1000 lb) anhydrous product

COD - 0.6 kg/kkg (0.6 lb/1000 lb) anhydrous product

Suspended Solids - 0.3 kg/kkg (0.3 lb/1000 lb) anhydrous product

Oil and Grease - 0.3 kg/kkg (0.3 lb/1000 lb) anhydrous product

Surfactant - 0.7 kg/kkg (0.7 lb/1000 lb) anhydrous product

#### Best Practicable Control Technology Currently Available Guidelines

The following thirty day average recommendations for effluent loadings are made with the understanding that there may be some firms on some occasions requiring additional loadings for washouts of equipment. Further, during any 24 hour period the limits could be allowed to slightly exceed 3 times the average as long as the thirty day average meets the guidelines. This will account for both variability of operation and treatment.

BOD<sub>5</sub> - 0.02 kg/kkg (0.02 lb/1000 lb) anhydrous product

COD - 0.09 kg/kkg (0.09 lb/1000 lb) anhydrous product

Suspended Solids - 0.03 kg/kkg (0.03 lb/1000 lb) anhydrous product

Oil and Grease - 0.03 kg/kkg (0.03 lb/1000 lb) anhydrous product

Surfactant - 0.07 kg/kkg (0.07 lb/1000 lb) anhydrous product

pH 6.0 - 9.0

Some small scale batch operated plants may have great difficulty in reaching these levels. Consideration should be given by the permit writing authority for modest relaxation of these levels where circumstances clearly warrant them.

#### Best Practicable Control Technology Currently Available

As indicated in the general discussion this process can be operated continuously in essentially a trouble-free manner. There is little room for improvement.

Other than the gland leakage and very occasional washouts this process has no effluent. Gland leakage around pump shafts is a universal problem wherever liquids are handled, particularly corrosive liquids. Because of the corrosive nature of the oleum, thorough washouts are mandatory prior to maintenance work being carried out on the equipment.

Integrated plants will have little difficulty meeting the levels of the guidelines. The washwater can be recycled and the leaks and spills run to the neutralization unit.

Biological secondary treatment will handle the residual wastes when they occur.

#### 202 - AIR-SO<sub>3</sub> SULFATION/SULFONATION

##### General

This process is in as widespread use as the oleum sulfonation (201), particularly for the sulfation of alcohols and ethoxylates. Although continuous and automatic, the Air - SO<sub>3</sub> process

is much more inclined to cause product degradation than the oleum unit.

Whenever the process is started up some material must be discarded due to low sulfonation making the material below specification. Promptly upon shutdown a thorough washdown is required to keep char formation to a minimum. There are mist knockdown scrubbers which will also contribute to waste water loadings.

#### Raw Waste Loading

Average expected raw waste loadings are:

BOD<sub>5</sub> - 3 kg/kkg (3 lb/1000 lb) anhydrous product

COD - 9 kg/kkg (9 lb/1000 lb) anhydrous product

Suspended Solids - 0.3 kg/kkg (0.3 lb/1000 lb)  
anhydrous product

Surfactant - 3 kg/kkg (3 lb/1000 lb) anhydrous  
product

Oil and Grease - 0.5 kg/kkg (0.5 lb/1000 lb)  
anhydrous product

#### Best Practicable Control Technology Currently Available Guidelines

Thirty day average recommendations are made on a similar basis as those for Subcategory 201 - Oleum Sulfonation. Because of product changes or mechanical failures some plants may, at times, have to exceed established effluent limits. Such cases have not been provided for in suggested guidelines. Therefore, regulatory agencies may wish to extend special consideration in such cases and write appropriate limitations into any permits they issue.

BOD<sub>5</sub> - 0.30 kg/kkg (0.30 lb/1000 lb) anhydrous product

COD - 1.35 kg/kkg (1.35 lb/1000 lb) anhydrous product

Suspended Solids - 0.03 kg/kkg (0.03 lb/1000 lb)  
anhydrous product

Surfactant - 0.30 kg/kkg (0.30 lb/1000 lb) anhydrous  
product

Oil and Grease - 0.05 kg/kkg (0.05 lb/1000 lb) anhydrous  
product

pH 6.0 - 9.0

### Best Practicable Control Technology Currently Available

This process too has received much research and development attention leaving little to be expected in the short term in the form of process improvement.

In-plant practices can significantly aid in reducing raw waste loads by handling much of the cleanup dry, or blending off the material into industrial cleaners, provided the firm is sufficiently integrated.

### Rationale and Assumptions

In small plants particularly, there must be accommodation made for the disposal of these rather minimal wastes, in that the off specification product could seriously impact the product quality if incorporated in that stream.

The raw waste loading has been structured higher than that for oleum sulfonation to acknowledge the product degradation which takes place when sulfonated material remains in the reaction area, requiring thorough washouts.

### 203 - SO3 SOLVENT AND VACUUM SULFONATION

#### General

Other than an occasional washout, this process is essentially free of waste water generation.

#### Raw Waste Loading

The following raw waste loading is expected:

BOD<sub>5</sub> - 3 kg/kkg (3 lb/1000 lb) anhydrous product

COD - 9 kg/kkg (9 lb/1000 lb) anhydrous product

Suspended Solids - 0.3 kg/kkg (0.30 lb/1000 lb)  
anhydrous product

Surfactant - 3 kg/kkg (3 lb/1000 lb) anhydrous  
product

Oil and Grease - 0.5 kg/kkg (0.5 lb/1000 lb) anhydrous  
product

### Best Practicable Control Technology Currently Available Guidelines

On a thirty day average basis, the following parameter levels are recommended:

BOD<sub>5</sub> - 0.30 kg/kkg (0.30 lb/1000 lb) anhydrous product



COD - 1.35 kg/kkg (1.35 lb/1000 lb) anhydrous product

Suspended Solids - 0.03 kg/kkg (0.03 lb/1000 lb)  
anhydrous product

Surfactant - 0.30 kg/kkg (0.30 lbs/1000 lbs) anhydrous  
product

Oil and Grease - 0.05 kg/kkg (0.05 lb/1000 lb) anhydrous  
product

pH 6.0 - 9.0

No additional allowance above that for variability of treatment need be made for startup, shutdown or upset conditions.

Best Practicable Control Technology Currently Available

Secondary biological treatment will adequately handle the wastes from this process.

Rationale

As in other categories, there will be some occasions when washouts will be required.

204 - SULFAMIC ACID SULFATION

General

Washouts are the only waste water effluents from this process.

Raw Waste Loading

The following raw waste loading is expected:

BOD<sub>5</sub> - 3 kg/kkg (3 lb/1000 lb) anhydrous product

COD - 9 kg/kkg (9 lb/1000 lb) anhydrous product

Suspended Solids - 0.3 kg/kkg (0.3 lb/1000 lb)  
anhydrous product

Surfactant - 3 kg/kkg (3 lb/1000 lb) anhydrous  
product

Oil and Grease - 0.5 kg/kkg (0.5 lb/1000 lb) anhy-  
drous product

Best Practicable Control Technology Currently Available Guidelines

On a thirty day average basis, the following parameter levels are recommended:

BOD<sub>5</sub> - 0.3 kg/kkg (0.3 lb/1000 lb) anhydrous product

COD - 1.35 kg/kkg (1.35 lb/1000 lb) anhydrous product

Suspended Solids - 0.03 kg/kkg (0.03 lb/1000 lb) anhydrous product

Surfactant - 0.3 kg/kkg (0.3 lb/1000 lb) anhydrous product

Oil and Grease - 0.05 kg/kkg (0.05 lb/1000 lb) anhydrous product

pH 6.0 - 9.0

No startup, shutdown or upset allowance is recommended.

Best Practicable Control Technology Currently Available

In order to comply with these guidelines the operator would be obliged to recycle the most wash water rather than sewer it.

Rationale

This reaction is normally carried out in batches. Reasonable housekeeping would permit the recycle via a holding tank for most of the washwater. As in other processes, this one can either accumulate unusable amounts of dilute washwater or occasionally have off-specification material to be disposed of. Unlike a large integrated plant, the firm using this process is unlikely to have any alternative other than disposal.

205 - CHLOROSULFONIC ACID SULFATION

General

This specialized process is another route to a high quality surfactant produced uniquely under mild reaction conditions. The by-product HCl is a significant distinction from other sulfonation processes. It is usually scrubbed out in a caustic solution with the formation of salt or dissolved in water for sale as muriatic acid.

Raw Waste Loading

The following values can be expected on a thirty day basis:

BOD<sub>5</sub> - 3 kg/kkg (3 lb/1000 lb) anhydrous product

COD - 9 kg/kkg (9 lb/1000 lb) anhydrous product

Suspended Solids - 0.3 kg/kkg (0.3 lb/1000 lb)  
anhydrous product

Surfactant - 3 kg/kkg (3 lb/1000 lb) anhydrous pro-  
duct

Oil and Grease - 0.5 kg/kkg (0.5 lb/1000 lb) anhydrous  
product

#### Best Practicable Control Technology Currently Available Guidelines

As a thirty day average the following parameter levels are recommended:

BOD<sub>5</sub> - 0.3 kg/kkg (0.3 lb/1000 lb) anhydrous product

COD - 1.35 kg/kkg (1.35 lb/1000 lb) anhydrous product

Suspended Solids - 0.03 kg/kkg (0.03 lb/1000 lb)  
anhydrous product

Surfactant - 0.30 kg/kkg (0.30 lb/1000 lb) anhydrous  
product

Oil and Grease - 0.05 kg/kkg (0.05 lb/1000 lb) anhy-  
drous product

pH 6.0 - 9.0

No upsets, startup or shutdown allowances are recommended.

#### Best Practicable Control Technology Currently Available

This important, moderately used process is optimized to the extent reasonably expected.

#### Rationale

The effluent washouts are minimal and the required loadings reasonable in relationship to the other processes. Recycling washouts can materially aid in meeting these guidelines. Biological secondary treatment is adequate to handle the expected raw waste load.

#### 206 - NEUTRALIZATION OF SULFURIC ACID ESTERS AND SULFONIC ACIDS

##### General

Neutralization is the essential step which converts the sulfonic acids or sulfuric acid esters into neutral surfactants. It is a

potential source of some oil and grease generation due to the possible hydrolysis of the sulfates. Occasional leaks and spills around the pump, valves, etc., are the only expected source of waste water contamination.

#### Raw Waste Loading

The following loadings can be expected:

BOD<sub>5</sub> - 0.10 kg/kkg (0.10 lb/1000 lb) anhydrous product

COD - 0.3 kg/kkg (0.3 lb/1000 lb) anhydrous product

Suspended Solids - 0.3 kg/kkg (0.3 lb/1000 lb) anhydrous product

Surfactant - 0.2 kg/kkg (0.2 lb/1000 lb) anhydrous product

Oil and Grease - 0.1 kg/kkg (0.1 lb/1000 lb) anhydrous product

#### Best Practicable Control Technology Currently Available Guidelines

On a thirty day average basis the following parameter values are recommended:

BOD<sub>5</sub> - 0.01 kg/kkg (0.01 lb/1000 lb) anhydrous product

COD - 0.05 kg/kkg (0.05 lb/1000 lb) anhydrous product

Suspended Solids - 0.03 kg/kkg (0.03 lb/1000 lb) anhydrous product

Surfactant - 0.02 kg/kkg (0.02 lb/1000 lb) anhydrous product

Oil and Grease - 0.01 kg/kkg (0.01 lb/1000 lb) anhydrous product

pH 6.0 - 9.0

No startup, shutdown or upset allowances are recommended.

#### Best Practicable Control Technology Currently Available

This process step is quite simple and usually continuous when in tandem with a continuous sulfonator. The biotreater in secondary treatment processing can accommodate the load. Recycle is probably the best way to eliminate waste loads.

#### Rationale

In a large volume operation of this type there will be occasional inadvertent leaks of valve and pump packing, spills due to maintenance disruption of piping, and occasional cleanup to repair the equipment, all necessitating the generation of dilute waste water streams. These streams are usually too dilute for recycle back into the process, but by use of small amounts of water, recycle is practical. By storage and recycle some of this washout water could diminish the problem and lead to product recovery later in the finishing process.

## 207 - SPRAY DRIED DETERGENTS

### General

This unit operation is one of the most critical - and the largest - as well as the most important of the detergent industry. Here, the final detergent particles are formed which must have the appropriate physical characteristics for solubility, packaging and storage.

Tower cleanliness is essential so that degradation products or material significantly different made in an earlier run do not contaminate the currently processed product. In such a case, the spray tower is put through a multi-stage, thorough cleaning process.

After the large dry "chunks" of adhering detergent are knocked down by hand, the tower walls are abraded. Finally, water is played over the surface to finish the cleaning process. The frequency of tower "turnaround" varies considerably in practice. Some towers operate for many weeks before shutdown and washing. Others may have a tower changeover sixteen times in a given month. In many cases there are product changeovers made on-the-fly requiring neither stoppage of spray tower operation nor cleanout.

Among many of the towers which have extended runs on one product, there is minimal discharge as waste water effluent. All of the dry product is recycled or sent to solid waste disposal. The washwater and scrubber water is all sent back into the process and recycled to extinction.

There are numerous possible sources of water containing contaminants originating in this process. They encompass crutcher cleanouts, packaging equipment cleanouts, storage area washouts, vent scrubbers, etc.

Characteristics of the exit air coming out of the spray tower are largely determined by the composition of the detergent formulation being dried. The increasing use of alcohol sulfates and ethoxylated alcohols as active ingredients has increased plume generation in this air stream which is not effectively eliminated by mechanical and electrostatic methods, thus

resulting in a significant volume of scrubber water being employed.

The total volume of scrubber water and washouts becomes too great to be recycled to extinction in some spray tower operations when they have to meet source air standards. Consequently, some waste water is expected to be sent to the sewer under these conditions.

A similar problem is faced by those who operate spray towers on a fast turnaround basis. They end up with much more washout waste water than they can handle via recycle.

In both cases cited above, the other immediately apparent alternative is to reuse all of the water, forcing the solids concentration of the tower slurry from around 70 percent to some lower value. This is not a suitable alternative, particularly from an environmental viewpoint, since excessive energy consumption would be required to drive off the additional water.

#### Raw Waste Loading

Under normal spray tower operation, a thirty day average raw waste loading can be expected to reach:

BOD<sub>5</sub> - 0.1 kg/kkg (0.1 lb/1000 lb) anhydrous product

COD - 0.3 kg/kkg (0.3 lb/1000 lb) anhydrous product

Suspended Solids - 0.1 kg/kkg (0.1 lb/1000 lb) anhydrous product

Surfactant - 0.2 kg/kkg (0.2 lb/1000 lb) anhydrous product

In towers facing particularly stringent air quality problems, the following waste water loadings can be expected:

BOD<sub>5</sub> - 0.8 kg/kkg (0.8 lb/1000 lb) anhydrous product

COD - 2.5 kg/kkg (2.5 lb/1000 lb) anhydrous product

Suspended Solids - 1.0 kg/kkg (1.0 lb/1000 lb) anhydrous product

Surfactant - 1.5 kg/kkg (1.5 lb/1000 lb) anhydrous product

Oil and Grease - 0.3 kg/kkg (0.3 lb/1000 lb) anhydrous product

In spray towers having fast turnarounds (more than 6 per month), for each added turnaround, the following additional waste water loadings can be expected:

BOD<sub>5</sub> - 2.0 kg/kkg (2.0 lb/1000 lb) anhydrous product

COD - 6.0 kg/kkg (6.0 lb/1000 lb) anhydrous product  
Suspended Solids - 2.0 kg/kkg (2.0 lb/1000 lb) anhydrous product  
Surfactant - 4.0 kg/kkg (4.0 lb/1000 lb) anhydrous product  
Oil and Grease - 0.3 kg/kkg (0.3 lb/1000 lb) anhydrous product

Best Practicable Control Technology Currently Available Guidelines

For normal spray tower operation the following thirty day average parameter values are recommended:

BOD<sub>5</sub> - 0.01 kg/kkg (0.01 lb/1000 lb) anhydrous product  
COD - 0.05 kg/kkg (0.05 lb/1000 lb) anhydrous product  
Suspended Solids - 0.01 kg/kkg (0.01 lb/1000 lb) anhydrous product  
Surfactant - 0.02 kg/kkg (0.02 lb/1000 lb) anhydrous product

pH - 6.0 - 9.0

No special startup, shutdown or upset allowances are recommended.

For spray towers operating under stringent air quality problems, the thirty day average parameter loading guideline recommendations are:

BOD<sub>5</sub> - 0.08 kg /kkg (0.08 lb/1000 lb) anhydrous product  
COD - 0.37 kg /kkg (0.37 lb/1000 lb) anhydrous product  
Suspended Solids - 0.10 kg /kkg (0.10 lb/1000 lb) anhydrous product  
Surfactant - 0.15 kg/kkg (0.15 lb/1000 lb) anhydrous product

Oil and Grease - 0.03 kg/kkg (0.03 lb/1000 lb) anhydrous product

pH - 6.0 - 9.0

For spray tower operation with fast turnaround, the following additional allowance should be made for each turnaround above 6 per month:

BOD<sub>5</sub> - 0.02 kg/kkg (0.02 lb/1000 lb) anhydrous product

COD - 0.09 kg/kkg (0.09 lb/1000 lb) anhydrous product

Suspended Solids - 0.02 kg/kkg (0.02 lb/1000 lb) anhydrous product

Surfactant - 0.04 kg/kkg (0.04 lb/1000 lb) anhydrous product

Oil and Grease - no additional allowance

pH - 6.0 - 9.0

This is in essence an upset allowance for shutdown and startup.

No other special upset allowances are recommended for spray tower operations in general.

#### Best Practicable Control Technology Currently Available

It is expected that the levels of effluent constituents can be met readily if the equivalent of cyclone scrubbers are used before electrostatic precipitators in the air stream exiting from the spray tower. Since the function of the water scrubbing is to chill the air as well as remove particulate matter, a significant step toward reduced effluent loading can be taken by substituting cooled recycle water for that used on a once through basis.

With the water recycled, a sufficient concentration can be built up in the water flow to make return to the detergent making process possible. Foaming is avoided by maintaining the surfactant concentration at a sufficiently high level in the recycled scrubber water. Though only a possible option for best practicable technology, this approach should be seriously considered for best available technology.

Ultimately, the secondary biotreater will have no difficulty processing the waste load from the spray tower area.

#### Rationale

The demands for clean air and clean water come into conflict in spray tower operation. In order to meet the increasingly tighter air pollution regulations while producing products which are more environmentally compatible, tower operation problems develop. These newer formulations contain increasing amounts of nonionic surfactants which are prone to produce an aerosol plume that persists in the exit tower gas.

A system of dry cyclone dust collectors followed by an electrostatic precipitator is suitable for removing the particulate matter present, but it does not influence the plume since it is a vapor.



By inserting a wet scrubber in between the cyclone dust collector and the electrostatic precipitator the particulate matter is further reduced and the organic aerosol vapors are condensed so that they can then be removed by the electrostatic precipitator.

Introduction of this scrubber water flow now converts a potential air contamination into a waste water problem. Since the materials removed in the scrubber are biodegradable and essentially the same product as that which is put into our sanitary sewers throughout the country, this is a satisfactory method of minimizing the environmental impact.

Additional study is needed in this area, particularly concerning the economics of installing sufficient tankage to enable the fast turnaround towers to approach total recycle.

## 208 - LIQUID DETERGENT MANUFACTURE

### General

There are numerous liquid detergent products made and it is likely that they are going to become more abundant as more emphasis is placed upon nonphosphate products. Many products, including heavy-duty detergents, are more amenable to convenient use and manufacture in the liquid form than as a dry powder.

The term "liquid detergents" embraces a large variety of formulations which fulfill an equally large spectrum of uses. The ingredients used to formulate the products have a wide response to such tests as BOD<sub>5</sub>. Consequently, the statement of any single raw waste loading could cause a significant problem to a given manufacturer.

In the process of preparing the liquid detergent, there are two main sources of waste water effluent, mixing equipment and distribution system washouts and filling equipment cleanup. Most operators recycle as much diluted product as possible, but, as in the case of spray tower operation, the total water volume cannot be economically recycled to extinction.

### Raw Waste Loading

On a thirty day average basis, the following raw waste loadings will be experienced:

BOD<sub>5</sub> - 2 kg/kkg (2 lb/1000 lb) anhydrous product

COD - 4 kg/kkg (4 lb/1000 lb) anhydrous product

Surfactant - 1.3 kg/kkg (1.3 lb/1000 lb) anhydrous product

However, when observing smaller firms, the raw waste loadings may get to:

BOD<sub>5</sub> - 5 kg/kkg (5 lb/1000 lb) anhydrous product

COD - 7 kg/kkg (7 lb/1000 lb) anhydrous product

Surfactant - 3.3 kg/kkg (3.3 lb/1000 lb) anhydrous product

This latter case is associated with the high use of common transfer lines for moving the product to filling lines, losses resulting from breaking hose connections and relatively short filling runs.

#### Best Practicable Control Technology Currently Available Guidelines

On a thirty day average basis, the following parameter levels are recommended:

BOD<sub>5</sub> - 0.2 kg/kkg (0.2 lb/1000 lb) anhydrous product

COD - 0.6 kg/kkg (0.6 lb/1000 lb) anhydrous product

Surfactant - 0.13 kg/kkg (0.13 lb/1000 lb) anhydrous product

pH - 6.0 - 9.0

There should be some accommodations made for the smaller operator where his loadings are marginally greater than those shown. Basically, this accommodation should be in the nature of an allowance for the number of product changes requiring complete purging and cleaning of filling lines. Another exception which should be noted is that the COD/BOD<sub>5</sub> ratio may rise to 5:1 or more due to the use of some relatively bio-hard industrial cleaner ingredients such as orthodichlorobenzene, hydrochloric acid, or chromic acid. Such compounds can upset the biota in BOD<sub>5</sub> tests, as well as giving a refractory residue. No allowance need be made for the suspended solids or oil and grease since the products marketed are normally clear, filtered fluids, devoid of suspended particles.

#### Best Practicable Control Technology Currently Available

Secondary biological treatment will adequately handle the waste water effluents from this process if good in-plant control is practiced to limit the amount of refractory materials.

#### Rationale

With an industry very much aware of market demands, there will be a continually changing array of formulations to meet new consumer preferences and environmental performance demands. There are generally two different markets for liquid detergents; household and industrial. In this latter market, many moderately sized operators supply a wide variety of special purpose detergents to

meet very specialized needs. Often fairly "exotic" materials are used.

Relatively small operators do not have the flexibility of operation of the large manufacturers. This, coupled with numerous small batches of product, creates special waste water problems, since there is no place to hold or recycle numerous, varied spills, leaks and washouts associated with the automated filling lines. The cut-off point in allowances becomes critical, then, since it could have severe economic consequences for some manufacturers. There are other special problems relating to analytical results of effluent evaluations. Due to the wide variety of products used in liquid formulations, fully acclimated cultures may not be available for gaining results which reflect the actual technical conditions.

### 209 - DRY DETERGENT BLENDING

#### General

Many different dry detergent blends are made for a multiplicity of industrial uses. The product is usually marketed in drums.

The customary practice is for many successive batches to be made in a given mixer before a wet washdown is required.

#### Raw Waste Loading

An average thirty day waste water loading would be:

BOD<sub>5</sub> - 0.1 kg/kkg (0.1 lb/1000 lb) anhydrous product

Suspended Solids - 0.1 kg/kkg (0.1 lb/1000 lbs) anhydrous product

COD - 0.5 kg/kkg (0.5 lb/1000 lb) anhydrous product

Surfactant - 0.1 kg/kkg (0.1 lb/1000 lb) anhydrous product

#### Best Practicable Control Technology Currently Available Guidelines

Based upon a thirty day average, the recommendations of parameter loadings are:

BOD<sub>5</sub> - 0.01 kg/kkg (0.01 lb/1000 lb) anhydrous product

COD - 0.08 kg/kkg (0.08 lb/1000 lb) anhydrous product

Suspended Solids - 0.01 kg/kkg (0.01 lb/1000 lb) anhydrous product

Surfactant - 0.01 kg/kkg (0.01 lb/1000 lb) anhydrous product

pH - 6.0 - 9.0

No additional allowance need be made for startup, shutdown, or upsets.

Best Practicable Control Technology Currently Available

Biological secondary treatment is adequate for the effluent involved.

Rationale

A wide variety of materials are formulated dry. Although little water is used, that which is required for the infrequent washings is critical. It will be very dilute and diverse in content, unsuitable for recycling.

210 - DRUM DRIED DETERGENTS

General

This well established process produces no effluent, but some provision must be made for those periods of mandatory washdown due to equipment failure or critical formulation change.

Raw Waste Loading

The average raw waste load which could be expected is:

BOD<sub>5</sub> - 0.1 kg/kkg (0.1 lb/1000 lb) anhydrous product

COD - 0.3 kg/kkg (0.3 lb/1000 lb) anhydrous product

Suspended Solids - 0.1 kg/kkg (0.1 lb/1000 lb) anhydrous product

Surfactant - 0.1 kg/kkg (0.1 lb/1000 lb) anhydrous product

Oil and Grease - 0.1 kg/kkg (0.1 lb/1000 lb) anhydrous product

Best Practicable Control Technology Currently Available Guidelines

On a thirty day average basis, the following parameter levels are recommended:

BOD<sub>5</sub> - 0.01 kg/kkg (0.01 lb/1000 lb) anhydrous

product

COD - 0.05 kg/kkg (0.05 lb/1000 lb) anhydrous product

Suspended Solids - 0.01 kg/kkg (0.01 lb/1000 lb) anhydrous product

Surfactant - 0.01 kg/kkg (0.01 lb/1000 lb) anhydrous product

Oil and Grease - 0.01 kg/kkg (0.01 lb/1000 lb) anhydrous product

pH - 6.0 - 9.0

No startup, shutdown or upset allowances are required. Due to the low values recommended, a total of three times the average should be allowed over any 24 hour period as long as during any thirty day period the guidelines are maintained.

#### Best Practicable Control Technology Currently Available

Secondary biological treatment can adequately handle the constituents.

#### Rationale

Even though the process is essentially dry, the slurry pans and other equipment will require an infrequent but necessary and thorough washout.

#### 211 - DETERGENT BARS AND CAKES

##### General

In the manufacture of detergent bars there is need for meticulous cleaning of equipment to insure that any product which may have been degraded due to adhering to hot process equipment is removed and disposed of.

The approximately 160 million pounds of synthetic toilet bar soap used in the U.S. is significant, yet modest when compared to the 600 million pounds of "natural" soap used in toilet bars.

##### Raw Waste Loading

The following raw waste load can be expected:

BOD<sub>5</sub> - 7 kg/kkg (7 lb/1000 lb) anhydrous product

COD - 22 kg/kkg (22 lb/1000 lb) anhydrous product

Suspended Solids - 2 kg/kkg (2 lb/1000 lb) anhy-

drous product

Surfactant - 5 kg/kkg (5 lb/1000 lb) anhydrous product

Oil and Grease - 0.2 kg/kkg (0.2 lb/1000 lb) anhydrous product

Best Practicable Control Technology Currently Available Guidelines

On the basis of a thirty day average, the following parameter levels are recommended:

BOD<sub>5</sub> - 0.7 kg/kkg (0.7 lb/1000 lb) anhydrous product

COD - 3.3 kg/kkg (3.3 lb/1000 lb) anhydrous product

Suspended Solids - 0.2 kg/kkg (0.2 lb/1000 lb) anhydrous product

Oil and Grease - 0.02 kg/kkg (0.02 lb/1000 lb) anhydrous product

pH - 6 - 9

No additional allowance is recommended for startup, shutdown or upsets. During any thirty day period an allowance of three times the average should be allowed over a 24 hour duration, provided that throughout the entire thirty day period the thirty day average is not exceeded.



## SECTION X

### BEST AVAILABLE TECHNOLOGY ECONOMICALLY ACHIEVABLE

#### Introduction

Best available technology economically achievable is expected to involve both improvement in the manufacturing process as well as adoption of the best available treatment technology that is within reason economically.

Not all of the processes identified in best practicable control technology currently available are expected to discharge less effluent by 1983. Several of these processes will have reached an optimum raw effluent reduction in compliance with the best practicable control technology currently available, attaining pollution levels so low that it is not feasible to reflect minor improvements in reduced guideline values. Only those which are expected to attain a significantly lower effluent level are discussed in detail in this section.

Improved end-of-pipe treatment is anticipated for further reduction of both the level of waste discharge and the variation of treatment efficiency from one day to the next. In recognition of the latter, it is recommended that the maximum single day values not be more than two times the thirty day averages. For those plants having treatment facilities that attain discharges consistent with the limitations applicable to the best practicable control, addition of sand or mixed media filtration should be considered. Plants with no treatment facilities, or grossly inadequate facilities, should consider two stage activated sludge, with one stage of the plug flow type, as a more cost effective alternative to equalization and single stage activated sludge.

TABLE 7-1

Best Available Technology Economically Achievable Guidelines Reflecting No Change From Best Practicable Control Technology Currently Available

Note: All values are reported as thirty day averages in kg/kgg (lb/1000 lb) of anhydrous product made in that subcategory. The pH for all subcategories is the range of 6.0 - 9.0.

	BOD <sub>5</sub>	COD	Suspended Solids	Surfactant	Oil & Grease
Fatty Acid by Fat Splitting-Hydrogenation Allowance Only	0.25	0.20	0.20	0.00	0.15
Soap From Fatty Acid Neutralization	0.01	0.05	0.02	0.00	0.01



Soap Flakes and Powders	0.01	0.05	0.01	0.00	0.01
Liquid Soaps	0.01	0.05	0.01	0.00	0.01
Oleum Sulfonation/Sulfation	0.02	0.09	0.03	0.03	0.07
S <sub>03</sub> Solvent and Vacuum Sulfonation	0.10	0.45	0.01	0.10	0.02
Neutralization of Acids	0.01	0.05	0.03	0.02	0.01
Detergent Dry Blending	0.01	0.08	0.01	0.01	0.005
Drum Dried Detergents	0.01	0.05	0.01	0.01	0.01

TABLE 7-2

Best Available Technology Economically Achievable Guidelines Reflecting Changes From Best Practicable Control Technology Currently Available

Note: All values are reported as thirty day averages in kg/kgg (lb/1000 lb) of anhydrous product made in that subcategory. The pH for all subcategories is the range of 6.0 - 9.0.

	BOD <sub>5</sub>	COD	Suspended Solids	Surfactant	Oil & Grease
Batch Kettle Soap	0.40	1.05	0.40	0.0	0.05
Fatty Acid by Fat Splitting	0.25	0.90	0.20	0.0	0.15
Glycerine Concentration	0.40	1.20	0.10	0.0	0.04
Glycerine Distillation	0.30	0.90	0.04	0.0	0.02
Bar Soaps	0.20	0.60	0.34	0.0	0.01
Air-S <sub>03</sub> Sulfation/Sulfonation	0.19	0.60	0.02	0.18	0.04
Sulfamic Acid Sulfation	0.10	0.45	0.01	0.10	0.02
Chlorosulfonic Acid Sulfation	0.15	0.75	0.02	0.15	0.03

Spray Dried Detergents					
Normal	0.01	0.08	0.01	0.02	0.005
Air Quality Restricted	0.08	0.35	0.10	0.15	0.03
Fast Turnaround	0.02	0.09	0.02	0.03	0.005
Liquid Detergents	0.05	0.23	0.005	0.05	0.005
Detergent Bars and Cakes	0.30	1.35	0.10	0.20	0.02

#### 101 - MODIFIED SOAP MANUFACTURE BY BATCH KETTLE

##### Best Available Technology Economically Achievable and Rationale

A significant reduction of waste water contamination volume can be made in the fat pretreatment step of kettle boiling soap manufacture by replacing the barometric condenser used in vacuum bleaching by a surface condenser. Such replacement would allow removal of volatile low molecular weight undesirables from the effluent. These can be destroyed by burning or perhaps recovered for sale by refining. This change is shown in Figure 26. An alternative approach for elimination of the pollutant load entrained in barometric condensates is use of a liquid film extraction unit ahead of the barometric condenser as currently practiced by one company within the industry.

##### Raw Waste Loading

The expected raw waste load is:

BOD<sub>5</sub> - 4 kg/kkg (4 lb/1000 lb) anhydrous soap

COD - 7 kg/kkg (7 lb/1000 lb) anhydrous soap

Suspended Solids - 4 kg/kkg (4 lb/1000 lb) anhydrous soap

Oil and Grease - 0.5 kg/kkg (0.5 lb/1000 lb) anhydrous soap

##### Best Available Technology Economically Achievable Guidelines

Please refer to guidelines in Table 7-2 at beginning of this Section.

#### 102 - FATTY ACID MANUFACTURE BY FAT SPLITTING

##### Best Available Technology Economically Achievable and Rationale

Referring to the schematic flow diagram 102, there are two ways of diminishing further the effluent streams from this unit. The

SECTION X  
LEVEL II TECHNOLOGY

101 - SOAP MANUFACTURE BY BATCH KETTLE : MODIFIED

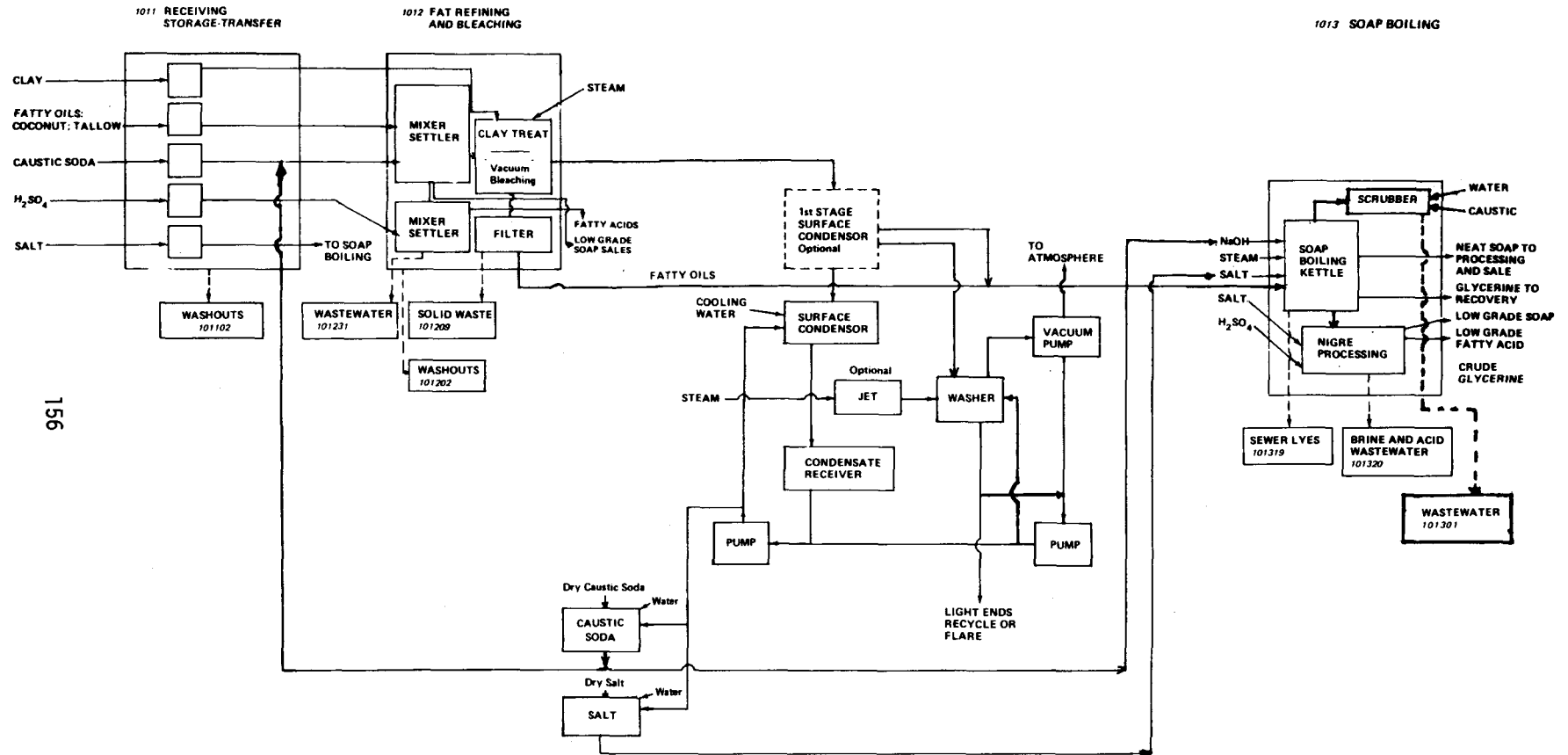

156

FIGURE 26

SECTION X and SECTION XI  
 LEVEL II TECHNOLOGY  
 and  
 LEVEL III TECHNOLOGY

102 Modified: FATTY ACID MANUFACTURE BY FAT SPLITTING

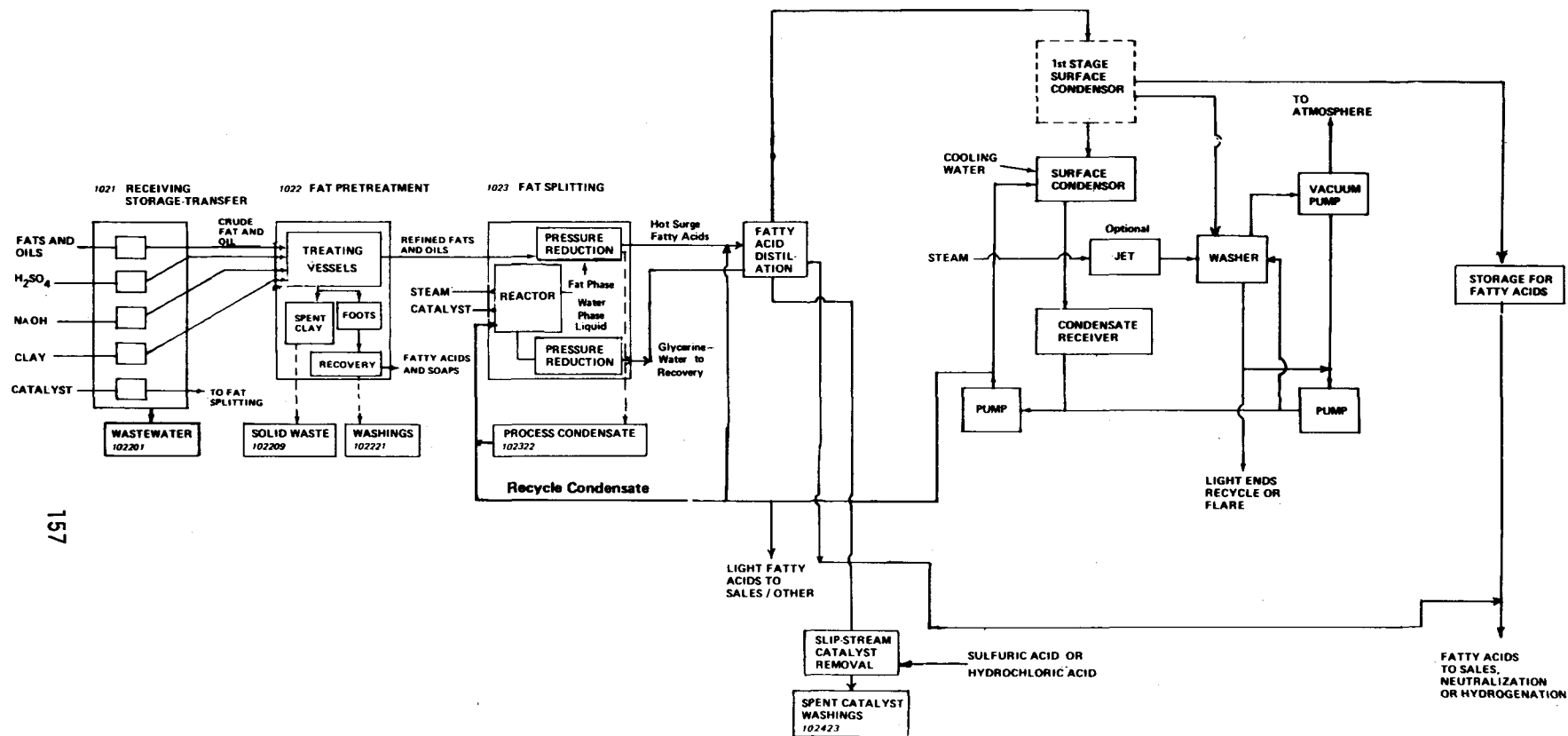

157

FIGURE 27

SECTION X and XI  
LEVEL II TECHNOLOGY  
and  
LEVEL III TECHNOLOGY

SCHEMATIC - 102-H: FATTY ACIDS MANUFACTURE : HYDROGENATION STEP, IF CARRIED OUT.

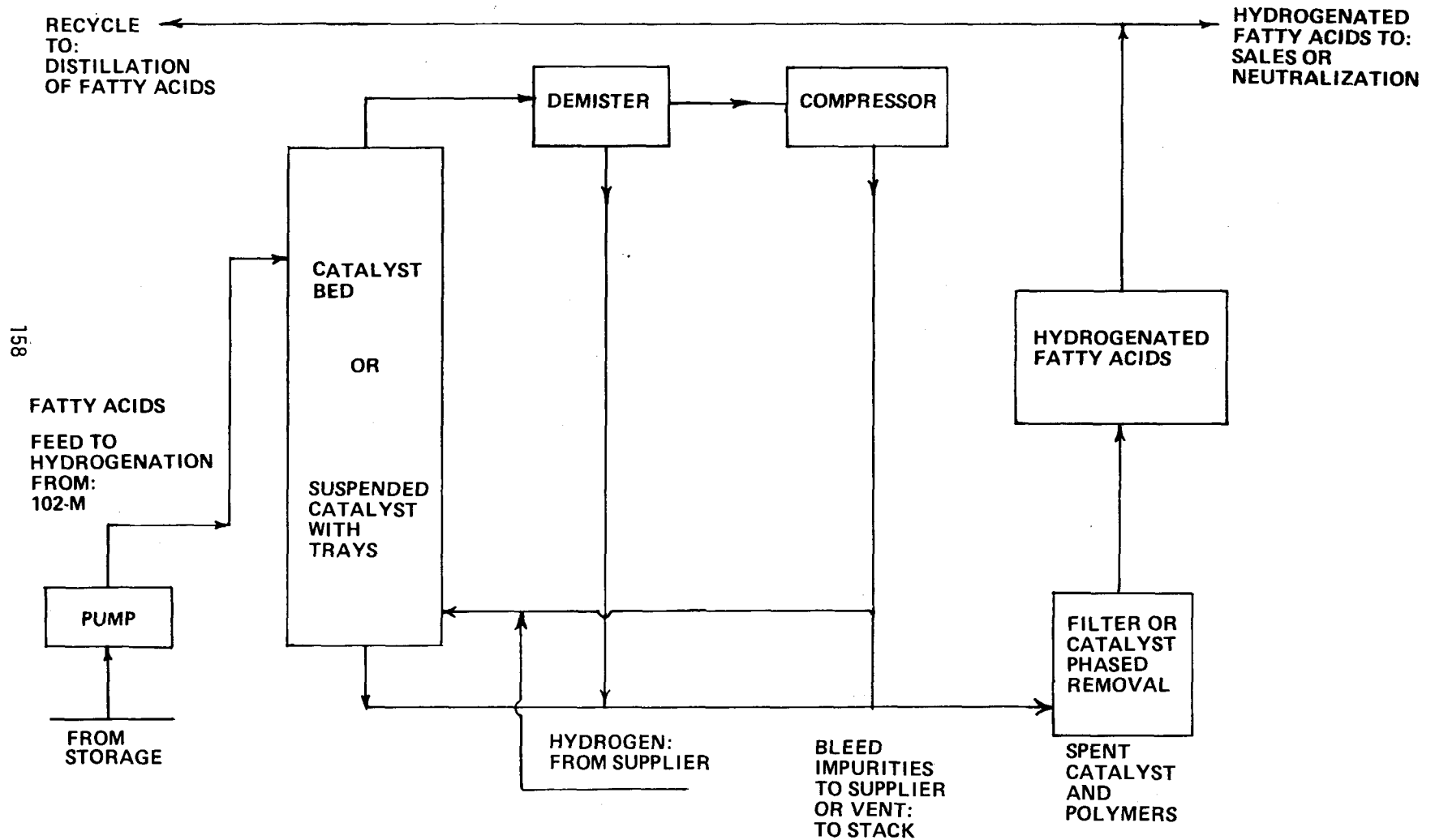

158

first of these is in-process recycle of the process condensate to the maximum extent possible. Secondly, the barometric condenser of the fatty acid distillation process can be replaced with a surface condenser thereby reducing by approximately 80 percent the amount of light ends going into the waste water stream during acid separation and purification. These light ends can be recovered for sale. The water stream can be then recycled back into the fat splitting process. The overall process (including hydrogenation) is shown in Figures 27 and 28. Use of a liquid film extraction unit ahead of the barometric condenser is also applicable to this subcategory.

#### Raw Waste Loadings

The following raw waste loadings can be expected.

BOD<sub>5</sub> - 2.5 kg/kkg (2.5 lb/1000 lb) anhydrous fatty acid

COD - 6.0 kg/kkg (6.0 lb/1000 lb) anhydrous fatty acid

Suspended Solids - 2.0 kg/kkg (2.0 lb/1000 lb) anhydrous  
fatty acid

Oil and Grease - 1.5 kg/kkg (1.5 lb/1000 lb) anhydrous  
fatty acid

#### Best Available Technology Economically Achievable Guidelines

Please refer to guidelines in Table 7-2 at beginning of this Section.

#### 104 - GLYCERINE RECOVERY AND CONCENTRATION

##### Best Available Technology Economically Achievable and Rationale

Replacement of the barometric legs in both the glycerine concentration and distillation processes would reduce glycerine losses and waste water loadings substantially. These changes are shown in Figures 29 and 30.

##### Raw Waste Load

The following average raw waste load is expected:

##### Glycerine Concentration

BOD<sub>5</sub> - 4.0 kg/kkg (4.0 lb/1000 lb) anhydrous glycerine

COD - 8.0 kg/kkg (8.0 lb/1000 lb) anhydrous glycerine

Suspended Solids - 1.0 kg/kkg ( 1.0 lb/1000 lb) anhydrous  
glycerine

Oil and Grease - 0.4 kg/kkg (0.4 lb/1000 lb) anhydrous

### 104 GLYCERINE RECOVERY

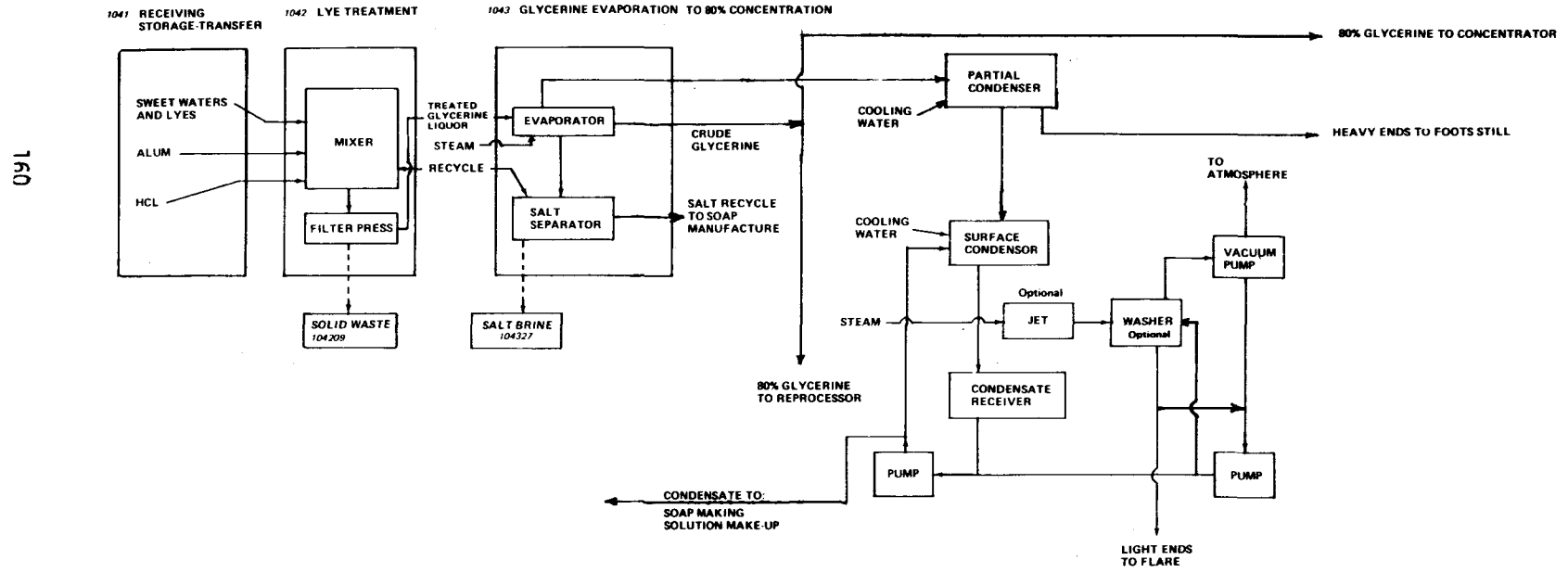

FIGURE 29

104-B: CONCENTRATION OF 80% GLYCERINE TO 99.5%

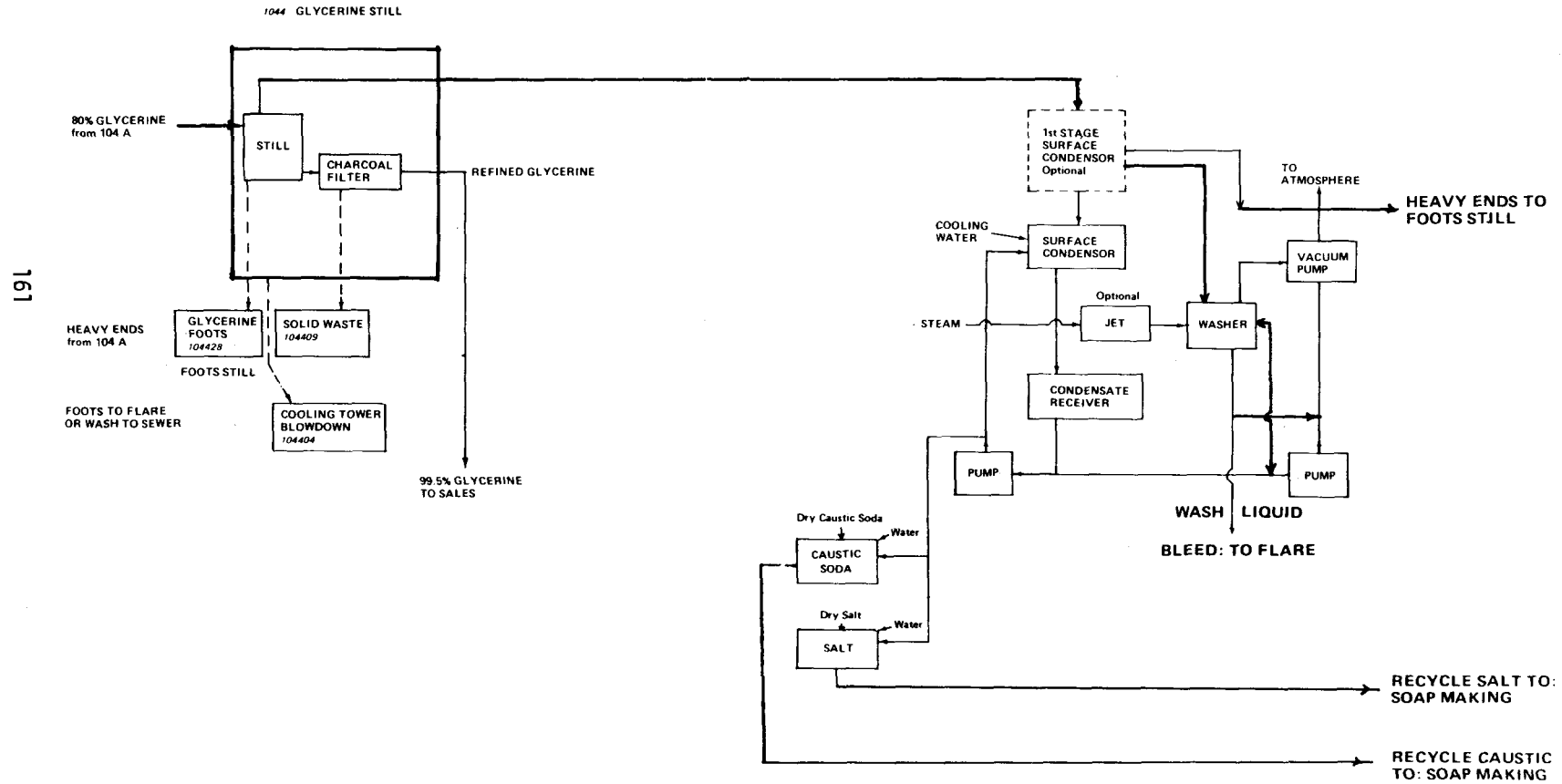

FIGURE 30



glycerine

Glycerine Distillation

BOD<sub>5</sub> - 3.0 kg/kg (3.0 lb/1000 lb) anhydrous glycerine

COD - 6.0 kg/kg (6.0 lb/1000 lb) anhydrous glycerine

Suspended Solids - 0.4 kg/kg (0.4 lb/1000 lb) anhydrous glycerine

Oil and Grease - 0.2 kg/kg (0.2 lb/1000 lb) anhydrous glycerine

Best Available Technology Economically Achievable Guidelines

Please refer to guidelines in Table 7-2 at beginning of this Section.

PROCESS 106 - BAR SOAPS

Best Available Technology Economically Achievable and Rationale

By 1983 there is an expectancy that the current relatively high BOD<sub>5</sub> waste load from air scrubbing will be improved to more closely match those operations which now are experiencing very low discharge rates. Installation of an atmospheric flash evaporation unit ahead of the vacuum drying unit, if such is employed, will materially reduce both carryover and utilities requirements.

Raw Waste Load

The following average raw waste load is expected:

BOD<sub>5</sub> - 2.0 kg /kg (2.0 lb/1000 lb) anhydrous soap

COD - 4.0 kg/kg (4.0 lb/1000 lb) anhydrous soap

Suspended Solids - 3.4 kg/kg (3.4 lb/1000 lb) anhydrous soap

Oil and Grease - 0.3 kg/kg (0.3 lb/1000 lb) anhydrous

Best Available Technology Economically Achievable Guidelines

Please refer to guidelines in Table 7-2 at beginning of this Section.

202 - AIR - SO<sub>3</sub> SULFATION AND SULFONATION

### Best Available Technology Economically Achievable Guidelines & Rationale

When vapor phase sulfur trioxide is used in sulfonation and sulfation processes, regardless of whether or not the vapor  $\text{SO}_3$  is diluted with nitrogen or air, three distinct types of feed and reactions for the application of sulfur trioxide need to be considered. The three feed stocks involved are 1) alkyl benzenes; 2) alpha or branched chain olefins; and 3) lauryl, fatty and/or ethoxylated alcohols. Please refer to figures 35-37.

The sulfur trioxide used in these three processes using different reactants may be prepared in three different ways. Although other methods of preparation are also possible, the following are those used commercially. The first process for producing sulfur trioxide is that of sulfur burning. In this process a liquid sulfur is vaporized and burned, usually in two stages, with air to form a sulfur trioxide-air mixture which can be fed directly in vapor form to the sulfonation/sulfation unit.

Another source of sulfur trioxide is that derived from high strength oleum. In this process, 65-70 percent oleum is the purchased feed component. It is heated in a reboiler operation to produce anhydrous vapor  $\text{SO}_3$ , as the concentration of the oleum is reduced to a 20 percent or even a lower level. The  $\text{SO}_3$  vapor is then diluted with air or nitrogen as the feed stream to the reactor. The sulfuric acid remaining is then sold or transferred to a sulfuric acid manufacturer for reconstitution to the higher 65-70 percent oleum level.

A third way of obtaining sulfur trioxide is by purchasing stabilized liquid sulfur trioxide. This source of sulfur trioxide can be brought in by tank cars or by an over-the-fence arrangement. It is of 99 percent or higher purity and in a stabilized form of one of its phases. It is stored over an inert gas, usually nitrogen, in order to preserve its stability in storage while in the liquid state.

For the purpose of costing,  $\text{SO}_3$  has been assumed to be manufactured by burning sulfur. It was further assumed that this does not add to the water effluent waste loading, since most of the losses from carrying out the preparation of  $\text{SO}_3$  would be in the vapor phase and therefore concerned only with problems of waste blowing into the atmosphere, if any.

In a sense, the purchase of sulfur trioxide in its stabilized form would lead to no different degree of air or water effluent waste. In the case of sulfur trioxide production from high concentrations of oleum, then a reboiler reactor, which produces the  $\text{SO}_3$  vapor, does lead to a liquid stream of sulfuric acid. However, as stated earlier, this is generally sent over the fence or even shipped for reconcentration to the original strength oleum. It thus presents no added water effluent flow except for spills and accidental incidents.

When an alkyl-benzene is employed as the raw material for reaction with sulfur trioxide, as well as in the other reactants mentioned above, there are side reactions which occur if sufficient heat removal and close temperature control is not attained. Therefore, generally useful, is the recycle of the cooled intermediate state alkyl-benzene sulfonic acid or the alkene sulfonic acid or the lauryl alcohol sulfuric acid back into the staged reaction loop, after cooling. In this way and with good temperature control, preferably in the range of 60-80 C (140-176 °F), high yield of the desired products may be obtained.

In the case of alkyl-benzene as a feed stock, it is desired principally to obtain the para-substituted product rather than those in other positions on the benzene ring. If high temperatures at the surface of contact are unfortunately reached, there is a strong tendency for both disproportionation and ring isomerization in the case of alkyl-benzene feed stock. In addition to the desired mono-substituted alkyl-benzene sulfonic acid, a fair amount of anhydrides of sulfonic acid are also obtained. These are essentially the anhydride of two alkyl-benzene sulfonic acid molecules. These anhydrides must be hydrated with water or otherwise reacted, in order to produce alkyl-benzene sulfonic acid of good quality. This reaction to produce the anhydrides is the result of the affinity for sulfur trioxide in the liquid phase to react with water, extracting it from combined hydrogen and hydroxyl groups, to form sulfuric acid. The sulfuric acid in the water phase cannot be reverted but must instead be decomposed by the dilution or hydration with added water in a separate step.

When either an alpha olefin or a branched chain olefin is to be sulfonated, several side reactions occur which diminish the product quality and result in by-products which must be dealt with. The principal reaction besides that of the sulfonation of the olefin to produce the alkene-sulfonic acid in the terminal bond position of the olefin, is that of bond migration where the sulfur trioxide reacts and moves along the chain, so that no longer does one obtain a terminal sulfonic acid product but one which is branch chained at the position of the sulfur trioxide addition.

Another reaction forming undesirable by-products that occurs with sulfur trioxide and an olefin is that of the formation of sultones, which are a cyclyzed form of the thiolone. These appear generally in three of their most stable forms, that is, alkyl- propane sultone, alkyl-butane sultone and also octane-alkyl sultone, all of which must first be destroyed before a useful product can be obtained.

The conversion of sultones is accomplished by direct reaction with caustic soda or sodium hydroxide, which produces the sodium hydroxy-sulfonate of the alkene product together with a sodium alkene sulfonate in stoichiometric proportions. The normal reaction product, alkene sulfonic acid, is simultaneously

neutralized with caustic soda to form the desired sodium alkene sulfonate and water.

In the case of sulfation reactions in which an alcohol, an ethoxylated alcohol or an ethoxylated phenol is used for sulfation with sulfur trioxide, the product formed is an organic sulfuric acid. In this case, the same by-products can occur as with oleum sulfation.

The reaction products from the alpha olefin or branched olefin must first be neutralized to produce the desired sodium alkene sulfonates before further hydration, whereas in the case of the direct reaction of sulfur trioxide with alkyl-benzene, the neutralization can follow hydration steps. Of course, an organic sulfuric acid requires no hydration.

In all cases of these three reactions there is usually a holding tank after a cyclone separation of vapor  $\text{SO}_3$  that is unreacted, and the liquid streams of product and sulfuric acid. For this reason the holding tank provides not only additional residence time for the completion of the formation of sulfonic acids or alkyl alcohol sulfuric acid, but completes the reaction so that a recycle stream can be returned to the sulfonator or sulfator stage in order to get increased heat transfer and diminish the possibility of double substitution of a sulfonic acid group.

Some of these reactions are carried out simultaneously in certain instances because alkyl benzene sulfonate and the fatty alcohol sulfates are both often blended for a better balanced detergent. This blending can best be done after the reaction loop but before the hydration and neutralization steps, and leads to superior blended products.

The neutralization of the reaction can be carried out with any alkaline neutralizing agent depending upon the product desired. For example, caustic soda, as earlier described, aqua ammonia, which will lead to the formation of an ammonium salt; potassium, or even ethanol amines can be used. In addition, when liquid detergents are being made, substances such as low molecular weight alcohol, urea, toluene and/or xylene sulfonates for hydrotropic agents can be also simultaneously made in tandem operations and blended before hydration and neutralization.

The most feasible means of decreasing water effluent contaminants and simultaneously of increasing the quality of the product, as it applies either to a batch or a continuous system assumed in BPCTCA technology, is the addition of dilution in the reaction step, increased agitation to diminish temperature elevations as a result of the exothermal nature of the reaction, or better contact between the vapor sulfur trioxide and the liquid reactant phases. Additionally, a batch counter-current process can be installed by utilizing two or more reaction loops, in which the fresh sulfonic acid in the form of sulfur trioxide, is introduced into the stream to the completion stage or holding stage of the

reaction in counter-current to the feed of the alkyl- benzene, the olefin, or a fatty acid alcohol. Such a batch counter-current arrangement is easily feasible and should be economically viable by the addition of one or more small reaction loops for a second and even third stage of the process.

Raw Waste Loadings

The following average raw waste loadings can be expected:

BOD<sub>5</sub> - 1.9 kg/kg (1.9 lb/1000 lb) anhydrous product

COD - 3.7 kg/kg (3.7 lb/1000 lb) anhydrous product

Suspended Solids - 0.2 kg/kg (0.2 lb/1000 lb) anhydrous product

Surfactant - 1.8 kg/kg (1.8 lb.1000 lb) anhydrous product

Oil and Grease - 0.4 kg/kg (0.4 lb/1000 lb) anhydrous product

Best Available Technology Economically Achievable Guidelines

Please refer to guidelines in Table 7-2 in this Section.

PROCESS 203 - S03 SOLVENT AND VACUUM SULFONATION

PROCESS 204 - SULFAMIC ACID SULFATION

PROCESS 205 - CHLOROSULFONIC ACID SULFATION

Best Available Technology Economically Achievable

Improved process control should reduce the waste loading.

Raw Waste Load

The following average raw waste loads are expected (all values given in kg/kg, lb/1000 lb of product produced).

	<u>BOD5</u>	<u>COD</u>	<u>Suspended Solids</u>	<u>Surfactant</u>	<u>Oil &amp; Grease</u>
203	1.0	3.0	0.1	0.1	0.2
204	1.0	3.0	0.1	0.1	0.2
205	1.5	5.0	0.2	1.5	0.3

Best Available Technology Economically Achievable Guidelines

Please see guidelines in Tables 7-1 and 7-2 at beginning of Section.

PROCESS 207 - SPRAY DRIED DETERGENTS

(AIR QUALITY RESTRICTION OPERATION)

Best Available Technology Economically Achievable and Rationale

As discussed in Section VII, installation of tandem chilled water scrubbers (one with high and one with low detergent concentration) to scrub the plume will enable meeting air pollution restrictions while materially reducing the water effluent load.

Raw Waste Load

The following average raw waste load is expected:

BOD<sub>5</sub> - 0.6 kg/kg (0.6 lb/1000 lb) anhydrous product

COD - 2.5 kg/kg (2.5 lb/1000 lb) anhydrous product

Suspended Solids - 0.7 kg/kg (0.7 lb/1000 lb) anhydrous product

Surfactant - 1.0 kg/kg (1.0 lb/1000 lb) anhydrous product

Oil and Grease - 0.2 kg/kg (0.2 lb/1000 lb) anhydrous product

Best Available Technology Economically Achievable Guidelines

Please refer to guidelines in Table 7-2 at beginning of this Section.

PROCESS 208 - LIQUID DETERGENTS

PROCESS 211 - DETERGENT BARS AND CAKES

Best Available Technology Economically Achievable and Rationale

Guidelines recommendations for both processes were reduced on the basis of expected greater control over product losses in washups and general manufacturing, including employment of technology covered under Bar Soaps.

Raw Waste Load

The following raw waste loads are expected (all values given in kg/kg, lb/1000 lb of anhydrous product.)

	<u>BOD<sub>5</sub></u>	<u>COD</u>	<u>Suspended Solids</u>	<u>Surfactant</u>	<u>Oil &amp; Grease</u>
208	0.5	1.5	----	0.5	---
211	3.0	9.0	1.0	2.0	0.2

Best Available Technology Economically Achievable Guidelines

Please refer to guidelines in the Table 7-2 at the beginning of this Section.

SECTION XI  
NEW SOURCE PERFORMANCE STANDARDS  
AND PRETREATMENT STANDARDS

Introduction

New source performance standards (NSPS), being that which would be employed in a new source of manufacture, offers an opportunity to start afresh in the design of production facilities. Reviewing candidate processes for minimized effluents has produced no great surprises. Soap and detergent making is a well established art. Still, a number of relevant, substantive concepts for improvement have emerged as well as a few fairly far from commercial realization. Bearing in mind the necessity of being very practical, in the discussion of all newer developments for NSPS, particular note has been made of the degree to which each technique has been reduced to acceptable commercial practice. The technology, in most categories, reflects the improvements developed in best available technology economically achievable. The guidelines for many of these subcategories will be the same for the two groups of technology. To simplify study of the recommendations, the guidelines are reported in tabular form with the processes given new limitations and special consideration in the text noted by an asterisk. The sign @ in the table indicates that the 1983 and new source guidelines are identical. Please refer to the corresponding guidelines discussion in SECTION X for extensions and exceptions recommended for the guidelines. These exceptions are applicable to both sets of guidelines.

Following the discussion of specific process improvements for new source performance standards is a review of process chemistry developments which deserve further continuing study for ultimate improvements in low effluent level products. As with all such "far out" developments, some of the concepts have greater probability for success than others. They are offered for the different perspectives they offer to this sophisticated art of soap and detergent manufacturing and formulating.



TABLE 8

New Source Performance Standards Guidelines

Note: All values reported are in kg/kg (lb/1000 lb) of anhydrous product made in that category. For all categories the guidelines pH is 6 - 9.

	BOD <sub>5</sub>	COD	Suspended Solids	Surfactant	Oil & Grease
Batch Kettle and Continous Soap@	0.40	1.05	0.40	--	0.05
Fatty Acid By Fat Splitting@	0.25	0.90	0.20	--	0.15
Soap From Fatty Acid Neutrali- zation@	0.01	0.05	0.02	--	0.01
Glycerine Recovery Concentration@	0.40	1.20	0.10	--	0.04
Distillation@	0.30	0.90	0.04	--	0.02
Soap Flakes And Powders@	0.01	0.05	0.01	--	0.01
Bar Soaps@	0.20	0.60	0.34	--	0.03
Liquid Soap@	0.01	0.05	0.01	--	0.01
Oleum Sulfation/ Sulfonation*	0.01	0.03	0.02	0.01	0.04
Air-SO <sub>3</sub> Sulfa- tion/Sulfonation*	0.09	0.40	0.09	0.09	0.02
SO <sub>3</sub> Solvent and Vacuum Sulfona- tion@	0.10	0.45	0.01	0.10	0.02
Sulfamic Acid Sulfation@	0.10	0.45	0.01	0.10	0.02
Chlorosulfonic Acid Sulfation@	0.15	0.75	0.02	0.15	0.03
Neutralization Of Acids@	0.01	0.05	0.03	0.02	0.01
Spray Dried Detergents Normal@	0.01	0.08	0.01	0.02	0.005
Air Quality Restricted@	0.08	0.35	0.10	0.15	0.03
Fast Turnaround@	0.02	0.09	0.02	0.03	0.005
Liquid Deter- gents@	0.05	0.23	0.005	0.05	0.005
Detergent Dry Blending@	0.01	0.08	0.01	0.01	0.005
Drum Dried Detergents@	0.01	0.05	0.01	0.01	0.01
Detergent Bars and Cakes@	0.30	1.35	0.10	0.20	0.02

## PROCESS DISCUSSION

### SOAP MANUFACTURE BY BATCH KETTLE

#### Soap Manufacture by Continuous Counter-Current Process

There appears to be little economic driving force for the construction of a totally new batch soap manufacturing installation, from fats and oils, in the United States in the foreseeable future. There will be replacement of some pieces of equipment as maintenance demands. Soap use is expected to hold constant at best. Particularly in toilet bars, there is continuing loss of soap volume to synthetic detergent bars where the hard water problems are severe.

A totally new installation, starting with fats and oils, will most likely be a continuous manufacturing process. Although initial capital investment and operating costs are the lowest attainable, use of a continuous unit entails the sacrifice of some manufacturing flexibility. For example, changeovers are accomplished more conveniently and/or economically with a batch kettle when it is desired to make a number of different base soaps, each of which requires different fatty raw materials input.

Technically, a continuous unit possesses two major advantages. It uses very little water, thus minimizing the problem of waste water disposal. Secondly, as the nigre is formed entirely in a solid state, its handling is greatly simplified. In areas where there is little or no market for the dark soaps derived from nigre, this is a distinct advantage. Please refer to Figure 33 for process details.

Manufacturing operations still require preliminary fat refining and bleaching, as shown in section 1012 of the schematic diagram for soap manufacture by batch kettle. Therefore, the waste streams from this process can be minimized only to the extent described in best available technology economically achievable. The volume of waste water currently generated by the batch kettle process can be reduced about 80 percent. Utilities are expected to run no more than 0.44¢ to 0.66¢/kg (0.2¢ to 0.3¢/1000 lb) of neat soap. Electricity use is somewhat increased by the requirements of the turbo-disperser motors and those for the centrifuge operations. This added cost would be approximately 0.22¢/kg (0.1¢/1000 lb) of soap product according to best estimates.

A significant reduction in operating cost would be expected in the substitution of the continuous processing for a batch kettle from reduced labor requirements. Instead of labor in the range of eight to ten men per shift for a kettle plant of circa 9 to 13.6 M kg (20 to 30 M lb) capacity per year or higher, it should

be no more than two or possibly three men per shift for a continuous unit, representing a striking reduction in labor costs. Through labor savings alone, capital investment for a continuous soap process should be recovered within ten years.

Realizing that improvements in the clay treatment and vacuum bleaching of the feed oils and fats are limited to the replacement of a barometric condenser by a two-stage surface condenser, and that only good operating cleanliness can further reduce the raw waste load, the best available demonstrated control technology guidelines consider a small allowance for wastes from fats and oils pretreatment but essentially none for the continuous saponification process.

By the use of centrifugation, the soaps or fats can be effectively separated from the salt and lye. Thus, all of these materials can be reprocessed and it would appear that recommended guideline levels that could easily be met in the continuous saponification plant are: BOD<sub>5</sub>, 0.20 kg/kkg; COD, 0.60 kg/kkg; suspended solids, 0.20 kg/kkg; and oil and grease, 0.05 kg/kkg.

#### Raw Waste Load

The following average raw waste load can be expected:

BOD<sub>5</sub> - 2 kg/kkg (2 lb/1000 lb) anhydrous soap

COD - 4 kg/kkg (4 lb/1000 lb) anhydrous soap

Suspended Solids - 2 kg/kkg (2 lb/1000 lb) anhydrous soap

Oil and Grease - 0.5 kg/kkg (0.5 lb/1000 lb) anhydrous soap

#### SOAP FROM FATTY ACID NEUTRALIZATION

##### General

In BADTC technology the manufacture of soap by fatty acid neutralization is regarded as the norm for the preparation of neat soap. It is depicted in Figure 34. Data reported here is a combination of field visits and contractor's engineering design parameters. Data from two installations has been integrated with additional information found in the literature.

##### BADTC Technology - Soap Manufacture

The continuous process makes use of proportioning pumps with interlocks and main control-interlocks for absolute rate of feeds flow, very similar to that outlined in the continuous saponification process. In this process turbodispersers are used which greatly enhance the contacting efficiency between the water and fatty acid or oil phases of the reactants. The reaction time is reduced to a matter of 10 to 15 minutes total within the reactor and separation systems.

The quality of product made from such a continuous operation is equivalent to or improved over that from the batch kettle. For example, the batch kettle process will result in an average content of free alkali, measured as  $\text{Na}_2\text{O}$ , of 0.5 percent to 0.75 percent. In the case of the continuous manufacturing operation (representing an average range of all contractors' claims) the free alkali is reduced tenfold to approximately 0.05 percent to 0.075 percent. Similarly, the salt content is reduced from 1 percent to 0.5 percent. The neat soap produced from this reaction needs to be dried from approximately 35 percent water content to the desired level. The drying process is considered separately.

Battery limit capital investment, including appropriate tankage for the reactants, will cost approximately \$500,000 for a 20 million pound per year plant. Direct operating labor will approximate \$60,000 per year using standard labor costs. Appropriate maintenance and administration costs would equal the direct labor costs. It is estimated that steam consumption will amount to approximately \$6,000 per year; electricity approximately \$10,000 per year, and cooling water approximately \$2,000 per year for a 20 million pound per year installation. It must be emphasized that this covers only the neutralization step for production of neat soap from fatty acids.

#### BAR SOAP - DRYING

The drying operation is no different than that in BATEA guidelines for solid bar soap manufacture. A surface condenser is indicated for use in place of the normal barometric condenser now generally utilized for soap drying, especially when vacuum drying operations are carried out for clear soaps.

The capital cost for the above drying operation (for the production of a bar soap extrudate) is estimated at \$200,000 for 9 M kg (20 M lb) per year of anhydrous soap capacity. Operating steam, electric and cooling water costs are the same as those shown for best available technology economically achievable.

#### SOLVENT PROCESS FOR SOAP MANUFACTURE

A process developed in the 1940's requires no water to make anhydrous soap and dynamite glycerine.

In the Kokatnur process fats or oils dissolved in heated kerosene (260-290C) (500-554F) are mixed under pressure with anhydrous caustic soda. The reaction takes place in ten minutes and produces dynamite grade glycerine. After drawing off the glycerine, the remaining mixture is released into an expansion chamber where evaporation of the kerosene yields anhydrous soap. The process has the following advantages:

1. Very short reaction time.

2. Use of kerosene prevents charring.
3. Absence of water reduces heat requirement.
4. Dynamite grade glycerine and anhydrous soap are obtained directly.

One major defect of the process is that there is no refining stage and traces of kerosene are left in the soap, making it impossible to market the product for toilet bar use. Without further refinement the soap is suitable only for limited industrial uses.

#### 201 - OLEUM SULFATION AND SULFONATION

Extensive contractor data indicates that, with good engineering design of the reactor and a minimum residence time prior to neutralization, the levels proposed for raw waste load can be readily met by a continuous process plant.

Compared to those for batch or semi-batch reverse feed systems, capital investments for a continuous process are estimated to be lower by \$66/kkg (\$30/1000 lb) of annual capacity. Operational savings are possible in the form of reduced labor costs, lower consumption of utilities, and higher conversion of feedstocks (0.8 to 1.0 percent) to products.

The continuous process is adaptable to almost any size installation from 900 thousand kg (2 million lb) per year upward. Please refer to Figure 35.

#### Raw Waste Loadings

The following average raw waste load can be expected:

BOD<sub>5</sub> - 0.1 kg/kkg (0.1 lb/1000 lb) anhydrous product

COD - 0.2 kg/kkg (0.2 lb/1000 lb) anhydrous product

Suspended Solids - 0.2 kg/kkg (0.2 lb/1000 lb) anhydrous product

Surfactant - 0.1 kg/kkg (0.1 lb/1000 lb) anhydrous product

Oil and Grease - 0.4 kg/kkg (0.4 lb/1000 lb) anhydrous product

#### S02 AIR-S03 SULFATION AND SULFONATION

BADTC guideline recommendations are based on process chains shown in Figures 35, 36 and 37. The process chain involves the reaction, hydration, neutralization and finishing steps for production of alkylated aromatics.

### Neutralization

NSPS guideline recommendations are based upon technology illustrated in Figures 35-37 related earlier, each covering a separate feed stock, i.e., alkyl aromatics, olefins and alcohols. The process variations reflect the particular chemical reaction characteristics of the feed stocks.

In an integrated plant utilizing products containing derivatives of all three feed stocks, superior blended products can be made by combining the reaction products after the reaction loop but prior to the hydration and neutralization steps. This procedure is particularly applicable to the blends of alkyl benzene sulfonate with fatty alcohol sulfates.

Performance of a new installation based upon continuous sulfonation/sulfation is expected to be improved moderately over already installed batch or batch counter current systems. The form of sulfur trioxide used will not influence the effluent water quality.

The cost depicted and guaranteed by a supplier shows utility demands as follows; electricity 0.9 to 1.1¢/kg (0.4 - 0.5¢/lb) of active material from the reaction; cooling water requirements of 0.1 - 0.2¢/kg (0.05 - 0.10¢/lb) of active product. The initial capital cost for this installation relates of course to plant size with economy of scale favoring large plants. For plants in the size range of 13.6M kg per year (30M lb per year) of active ingredient, and based upon a 92 percent stream factor, capital amounts to \$88-110/kkg (\$40-50/1000 lb) annually product capacity.

Use of stabilized liquid sulfur trioxide is assumed. If sulfur trioxide is produced by sulfur burning, this is considered to be a separate unit, and the economics and the justification covered in the water effluent.

### Raw Waste Load

The following raw waste load can be expected:

BOD<sub>5</sub> - 0.9 kg/kkg (0.9 lb/1000 lb) anhydrous product

COD - 2.7 kg/kkg (2.7 lb/1000 lb) anhydrous product

Suspended Solids - 0.9 kg/kkg (0.9 lb.1000 lb) anhydrous product

Surfactant - 0.9 kg/kkg (0.9 lb/1000 lb) anhydrous product

Oil and Grease - 0.2 kg/kkg (0.2 lb/1000 lb) anhydrous product

SECTION X and XI  
LEVEL II TECHNOLOGY  
and  
LEVEL III TECHNOLOGY

SCHEMATIC FLOW DIAGRAM - 201 and 206

CONTINUOUS DETERGENT SLURRY PROCESSING PLANT  
HIGH-ACTIVE ALKYLATE SULFONATION WITH OLEUM : FEED A  
LOW  $\text{Na}_2\text{SO}_4$  CONTENT

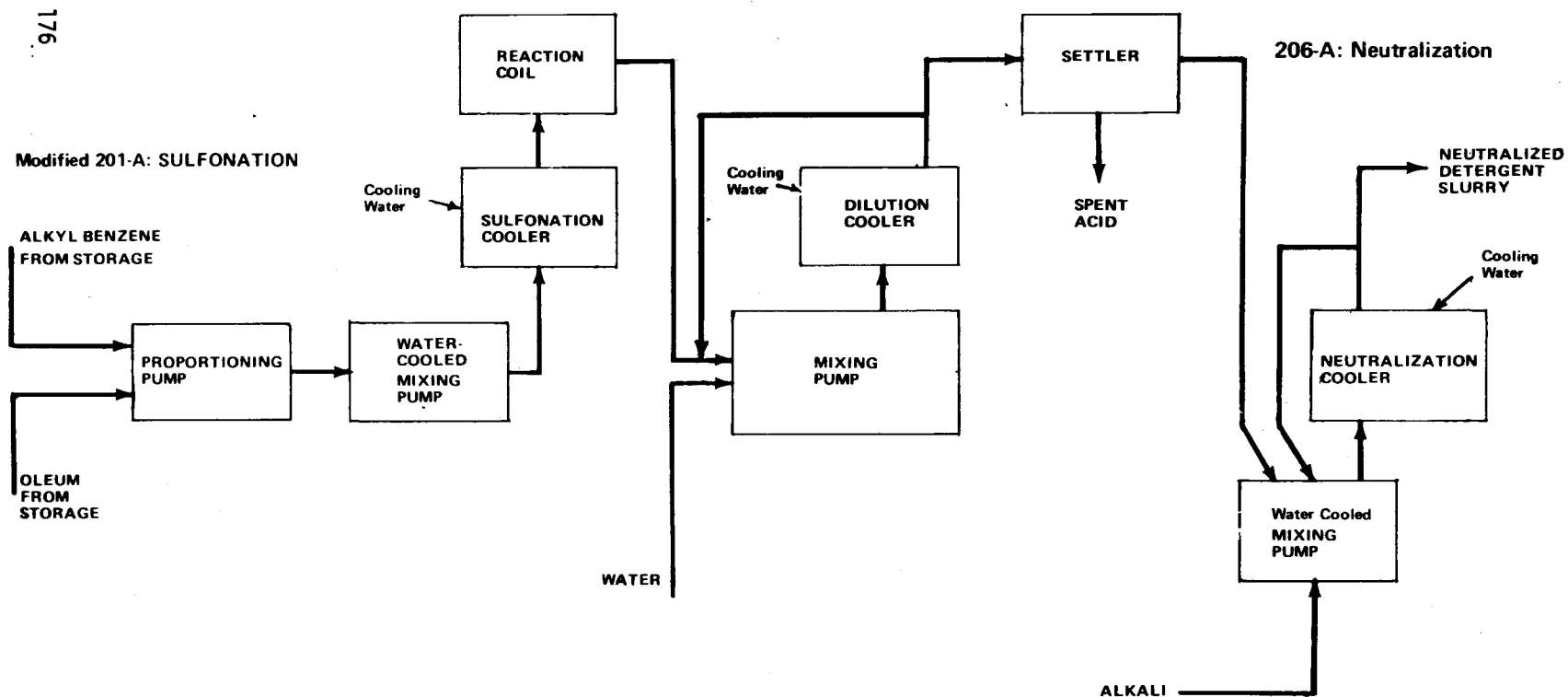
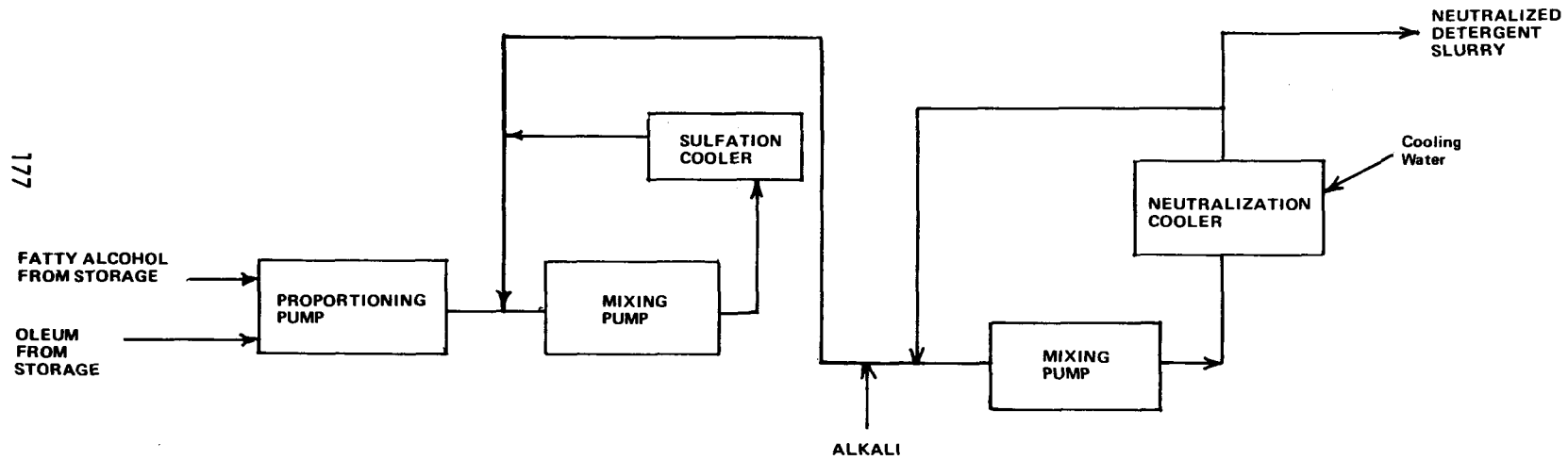

FIGURE 31

SCHEMATIC FLOW DIAGRAM — 201 MODIFIED  
CONTINUOUS DETERGENT SLURRY PROCESSING PLANT  
FATTY ALCOHOL SULFATION WITH OLEUM : FEEDS B and C



Modified: 201-B and C : SULFATION

201-B and C : NEUTRALIZATION

FIGURE 32



SECTION XI  
LEVEL III TECHNOLOGY

108: SOAP MANUFACTURE BY CONTINUOUS SAPONIFICATION

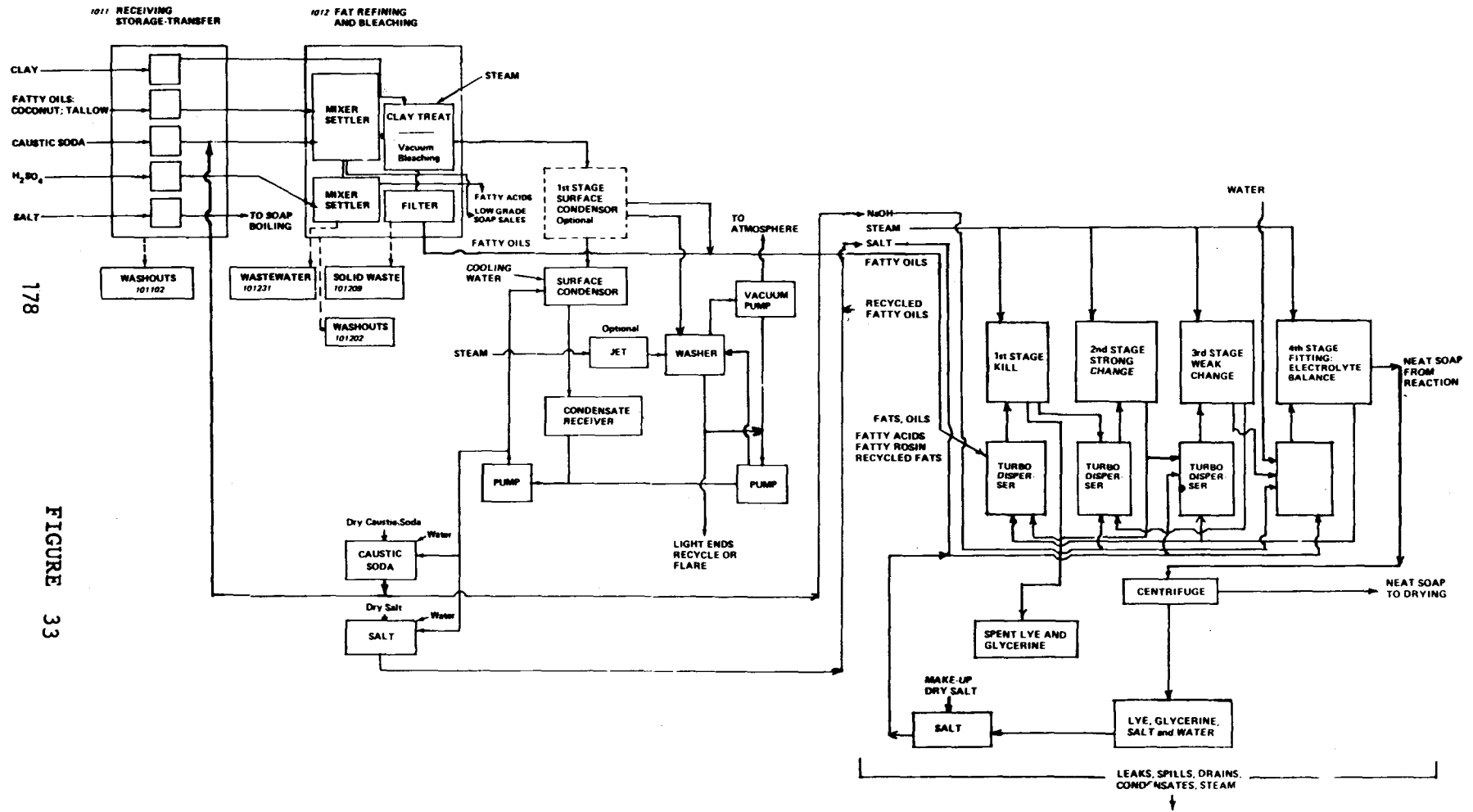

178

FIGURE 33

SECTION XI  
LEVEL III TECHNOLOGY

103 Modified: SOAP BY CONTINUOUS FATTY ACID NEUTRALIZATION

Section 1062-Modified:  
NEAT SOAP DRYING: FOR BAR SOAPS

179

FIGURE 34

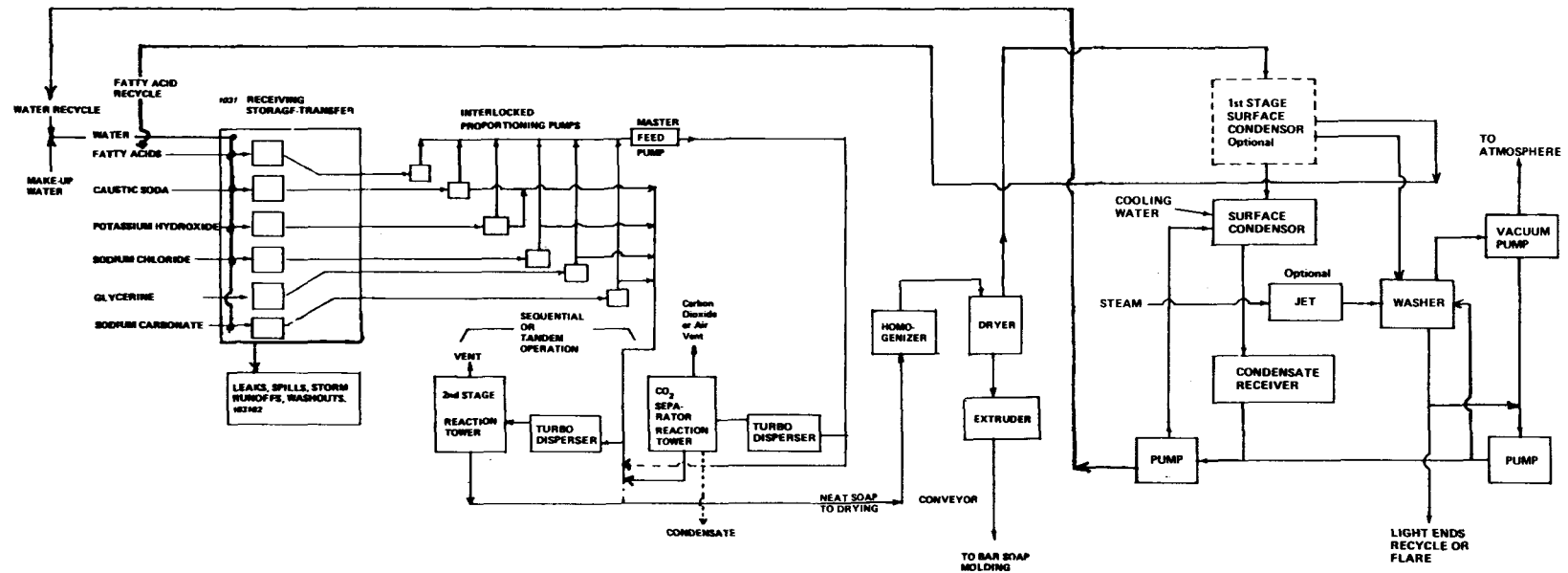

SECTION XI  
LEVEL III TECHNOLOGY

COMBINED PROCESSES

Modified 202 :  $\text{SO}_3$  - SULFONATION / SULFATION PROCESSES - CONTINUOUS

AND

Modified 206 : NEUTRALIZATION OF SULFONIC OR ALKYL SULFURIC ACID PROCESSES - CONTINUOUS

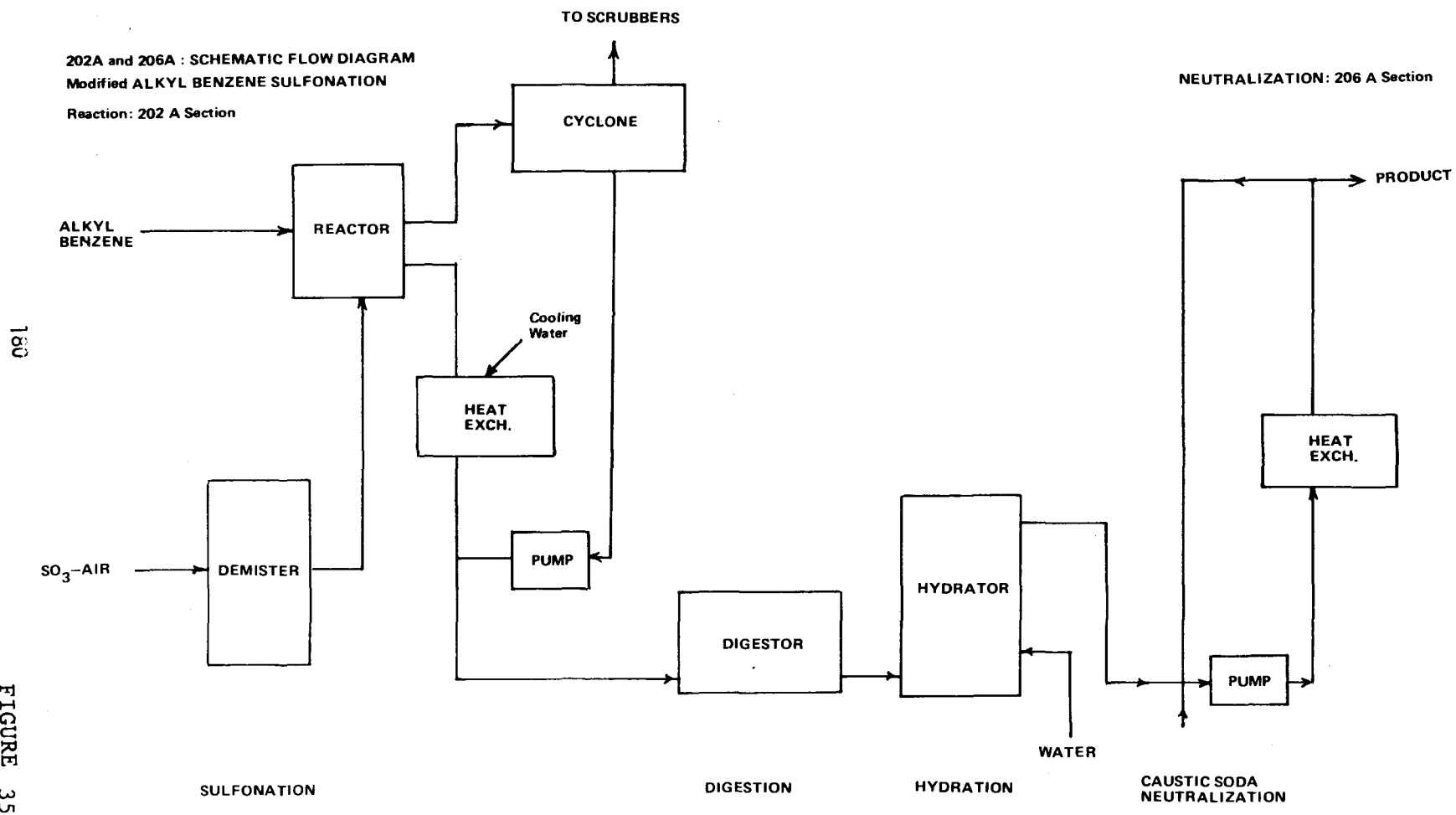

180

FIGURE 35

SECTION XI  
LEVEL III TECHNOLOGY

SCHEMATIC FLOW DIAGRAM  
202 C and 206 C: Modified - Combined

FATTY ALCOHOL SULFATION : WITH  $\text{SO}_3$

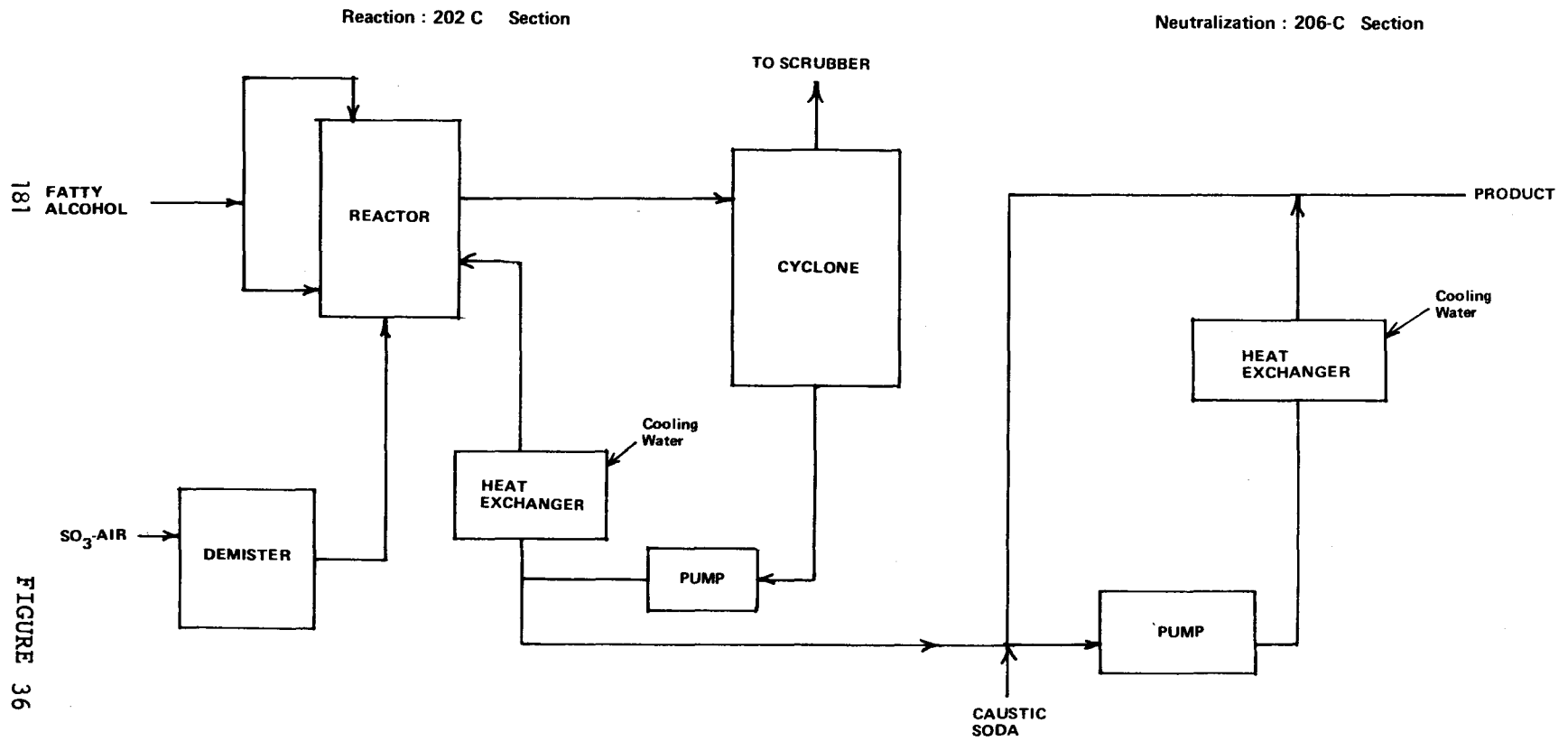

FIGURE 36

SECTION XI  
LEVEL III TECHNOLOGY

SCHEMATIC FLOW DIAGRAM – COMBINED 202B and 206B

ALPHA - OLEFIN SULFONATION WITH  $\text{SO}_3$

Reaction: 202 B Section

Neutralization : 206 B Section

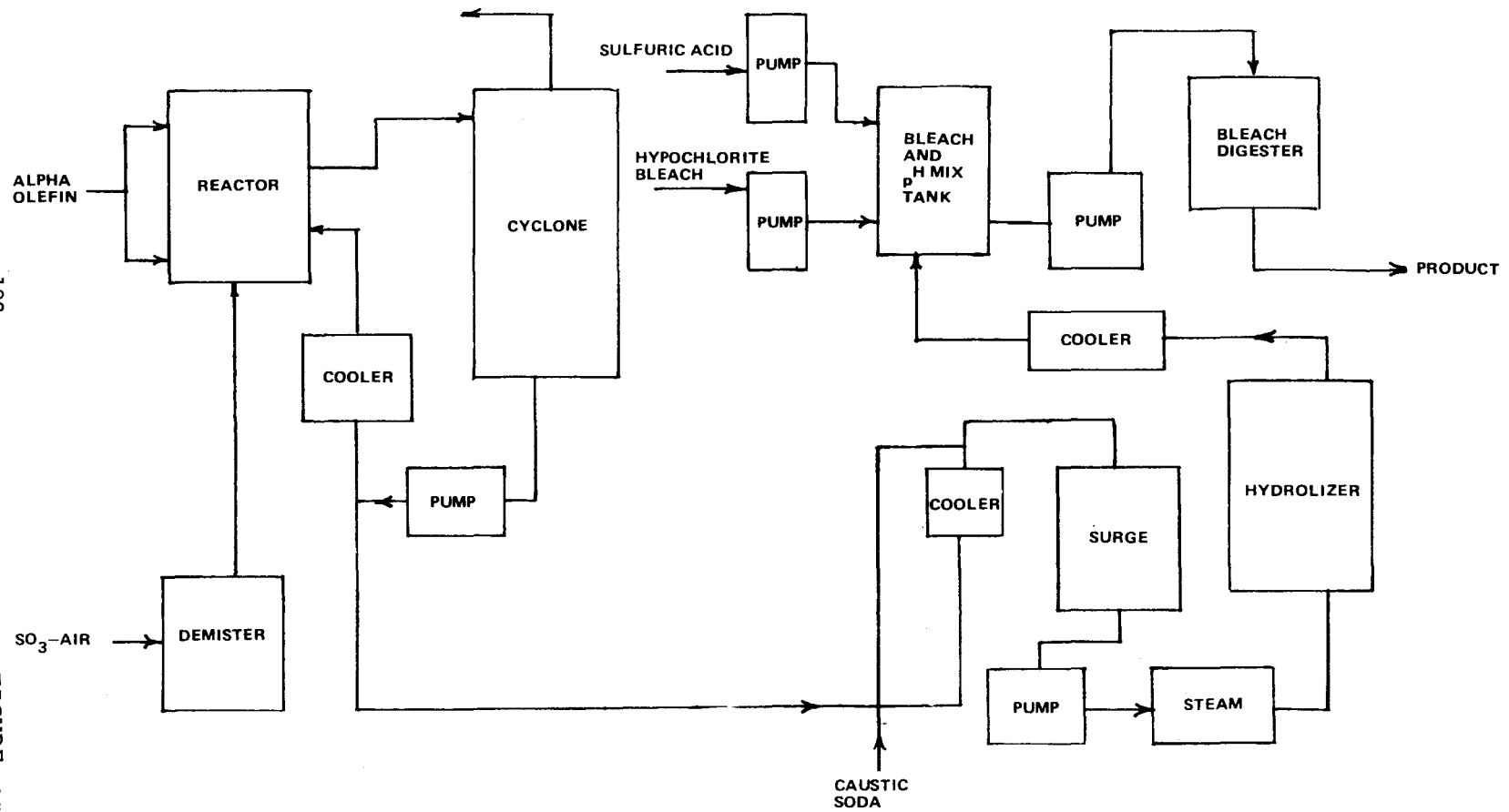

182

FIGURE 37

## PRETREATMENT REQUIREMENTS

In this section of the report those pollutants capable of disrupting, or likely to disrupt, the operation of a publicly owned waste water treatment plant are cited. It should be fully understood that it is not the intent to provide limits or other standards which would in effect supplant any sewer use ordinance developed and now being enforced by a central authority. In fact, every authority that owns a collection and treatment system should have an up-to-date sewer use ordinance which would enable it to regulate the types and quantity of industrial wastes admitted to its system. The purpose of this section is to point out possible problem areas and indicate applicable control measures.

With the exception of dissolved mineral salts there is essentially no pollutant in the wastes from soap and detergent manufacturers that cannot be removed at high levels of efficiency in a central plant.

### Fats and Oils

Fats and oils from soap plants are readily degradable. Whenever excessive fats, oils or greases are discharged, or whenever a safeguard against such a discharge is required, the waste should be passed through a gravity type separator prior to discharge to the central system. This type of pretreatment serves to remove up to 90 percent of the free oils which are the primary source of problems in both sewers and the treatment plant.

As previously discussed, the well-designed fat trap is similar to a primary clarifier in a municipal plant. An appropriate size for a large soap plant would be rated 2078 l/day/1 sq m (600 gallons/day/square foot). Residence time should be about 1 hour. Such a fat trap, with a radial flow to the perimeter discharge weir and a rotating scraper arm which moves the fat layer in front of the arm and thence into a well, will do an excellent job and provide essentially complete removal.

The underflow from such a fat trap will have a high treatable concentration of biodegradable organics. In one of the soap plants observed in this study a reserve of the underflow is retained in tanks to be used as a feed for the biological treater when only a few units of the plant are operating.

If the pollutant is a low molecular weight mineral solvent which has a low water solubility the same treatment mechanism can be employed. The captured material should be burned or processed for reuse. The non-flotables and the liquid phase should be passed on to the central treatment plant.

The efficiency of the fat trap must be maintained and routine inspections should be made by the proper authorities.

### Fats and Oils - Detergent Plants

Detergent plants will have oil and grease effluents more like the hydrocarbons encountered in the organic chemical industry; namely, they will be of fossil or petroleum origin rather than from natural fats. These hydrocarbons are not as readily degraded as those originating from the soap plant. The only analytical method, as described in Standard Methods, makes no differentiation between the two types of hydrocarbons. Until such a test can be devised it would be unfair to set a standard based on the least degradable product and make the more degradable product conform to it. Additionally, from an economic standpoint it is most important to make a differentiation in treatability. The problem is accentuated in that the industrial detergents will probably contain more hydrocarbons extracted in the hexane extractable test that are difficult to degrade than will the household detergents.

### Zinc

Concentrations of zinc which could lead to problems at the central facility have not been found in the waste water examined or in the data analyzed. The best information available would indicate that zinc concentrations of between 5 and 100 mg/l in the biological portion of the central plant could slow the rate of assimilation. Therefore, any concentration of not more than 5 mg/l would appear to be a satisfactory process effluent level. The observed values have been less than 4 mg/l. The relationship of zinc to the activity of nitrifying bacteria is under study in EPA. The results could have an effect on this standard.

Should a zinc problem arise, pretreatment employing alkaline precipitation is the most effective means of reducing zinc levels to satisfactory concentrations in process effluent. This should be carried out at pH values between 8.5 and 9.5 in the coagulation unit and at surface loadings of 1627 l - 20377 l/sq m (400-5000 gpd/sq ft) in the sedimentation unit. The sludge should be dewatered and incinerated or dried prior to disposal as a solid waste.

### Industrial and Institutional Cleaners

A number of soap and detergent manufacturers studied produce industrial cleaners which contain phosphoric and hydrofluoric acids; and organics such as chlorinated benzenes. The implication of the first two substances is clear and whenever they are used, strict in-house control steps should be exercised to control their discharge. The problem of chlorinated organic discharge is potentially more serious. These materials used in such applications as acid cleaners are moderately to highly toxic to man and may have a deleterious effect on waste treatment plants and on receiving waters. It is expected that treatability of these compounds is being studied by the industries

manufacturing them. It is suggested that further definition of their impact, and discussions of in-house and pretreatment control measures await the completion of those studies.

Many insitutional cleaners may have biocidal or biostatic materials incorporated in their formulation, and relatively large amounts of such materials in a discharge could interfere with normal operation of biological treatment systems. As in the case of industrial cleaners, strict in-house control should be exercised to control discharge of these materials.

Should pretreatment be necessary for industrial and institution cleaners, it would have to be in the nature of chemical-physical treatment designed to remove the specific materials involved.





## SECTION XII

### ACKNOWLEDGEMENTS

The Environmental Protection Agency wishes to acknowledge the contributions to the project by Colin A. Houston & Associates, Inc., Mamaroneck, New York. Messrs. Colin A. Houston, Frederick C. Herot, Charles H. Daniels and Ms. Susan M. Weisman, with the able assistance of their consultants Mr. George C. Feighner, Dr. Allen W. Fleer and Mr. Robert W. Okey, conducted the detailed technical study and drafted the initial report on which this document is based.

Because of the wide-ranging scope of the study, there was occasion to call upon many individuals and organizations for assistance in the course of bringing it to completion. Many people, both as individuals and as members of various organizations, responded with the utmost courtesy and generosity. We regret that space does not permit their individual citation, but the debt owed to each and every one of them is gratefully acknowledged.

Throughout the country, soap, detergent and fatty acid producers, large and small, graciously assisted in providing process information and opening up their plants to detailed study and sampling. Three trade associations performed valuable liaison functions in making the project a truly cooperative one; the Soap and Detergent Association, the Chemical Specialties Manufacturers Association, and the International Sanitary Supply Association.

Special help was received from members of the Environmental Protection staffs in Regions II, IV, V, VI and VIII. As an example, Mr. William Cloward, Chief, Industrial Waste Section, Region IV, actively contributed to all stages of the project, including participation in the in-plant sampling program. Many of the accomplishments of the sampling program are attributable to the assistance and analytical support received from the laboratory of the Division of Water Pollution Control, Louisiana Wildlife and Fisheries Commission, Baton Rouge, Louisiana and the following Environmental Protection Agency laboratories: Analytical Quality Control Laboratory, Cincinnati, Ohio; Robert S. Kerr Water Research Center, Ada, Oklahoma; and the Regional Laboratories in Athens, Georgia; Evansville, Indiana; Annapolis, Maryland and Kansas City, Kansas.

A lasting indebtedness is acknowledged to those in the Environmental Protection Agency who assisted in the project from inception of the study through preparation and review of the report. Especially deserving recognition are: Ms. Jan Beale, John Ciancia, Ms. Patricia Dugan, Ernst Hall, Ms. Frances Hansborough, Richard Insinga, Thomas Kopp, Ray McDevitt, Ronald McSwinney, David Mears, John Riley, Ms. Jaye Swanson and George Webster.



### SECTION XIII

#### REFERENCES

1. Adams, Roger, et al. Organic Reactions. Vol. IV. John Wiley and Sons (1948).
2. Air Plastics, Inc. Cincinnati, Ohio. Pollution Control Equipment. Brochure No. 7201A. January 22 (1973)
3. Air Pollution Control District, County of Los Angeles, California. Concentration and Flow Rates of Particulate Matter: Tests at Plant G. March 16, (1973)
4. Altman, Philip L. and Dittmer, Dorothy S. Environmental Biology. Federation of American Societies for Experimental Biology. Bethesda, Maryland. (1966)
5. American Chemical Society. 1972-1973 Lab Guide. ACS. Washington, D. C. (1972)
6. American Public Health Association. Standard Methods for the Examination of Water and Waste Waters. 13th Edition. APHA. Washington, D. C. (1971)
7. Appraisal of Granular Carbon Contacting. Phase III Engineering Design and Cost Estimate of Granular Carbon tertiary Waste Water Treatment Plant. U. S. Department of the Interior, Federal Water Pollution Control Administration, Ohio Basin Region. Cincinnati, Ohio.
8. Badger, W. L. and McCabe, W. L. Elements of Chemical Engineering. McGraw-Hill Company. York, Pa. (1936)
9. Balalrishnan, S., Williamson, D. E., and Okey, R. W. State of the Art Review of Sludge Incineration Practice. Federal Water Quality Administration. Dept. of the Interior, No. 17070, DIV Ap. (1970)
10. Ballestra, M. Sulfonic Acids Neutralization with Sodium Carbonate and Water Catalyst. U. S. Patent No. 3, 180, 699 (1965)
11. Bell, Doug. Report of Office of Air Programs. Emission Testing Branch. Augusta, Ga. (1972)
12. Benedikt. Chemical Analysis of Oils, Fats and Waxes. (1895)

13. Benoit, R. J. and Okey, R. W. Effect of Presulfidation on the Cotreatment of Plating Waste and Domestic Sewage by Activated Sludge. Report to Connecticut Research Commission. (1970)
14. Black, J. F. Radiochemical Production of Sulfonates from Linear Paraffins. Esso Research and Engineering. U. S. Patent 3,324,387. (1967)
15. Black, J. F. Radiation Source for Sulfonation Using Sulfur Dioxide. Journal Applied Radiation and Isotopes Vol. 1, pp 256 (1957)
16. Blakeway, et al. Jet Reactor for Sulfonation. Colgate Palmolive Company. U. S. Patent 3,346 505. (1967)
17. Blinoff, V. Sulfate Neutralization with Sodium Bicarbonate and Dry Ice. American Alcolac Corp. U. S. Patent 2,975,141 (1961)
18. Ballestra, SPA. Manufacture of Synthetic Detergents. Household and Personal Products Industry, pp 49-50. Milano, Italy. January (1973)
19. Bord, R. S. A Study of Sludge Handling and Disposal. USDI. FWPC. May (1962)
20. Brooks, R. J. and B. J. Use of Stabilized Sulfur Trioxide in Sulfonation. Chemithon Corp. U. S. Patent 3,259,645. (1966)
21. Brooks, R. J. Improved Process for Sulfonation Using Sulfur Trioxide. Chemithon Corp. U. S. Patent 3,350,428 (1967)
22. Bureau of the Census. 1967 Census of Manufactures. Concentration Ratios in Manufacturing, Part 3: Employment, Payrolls, Capital Expenditures and Other General Statistics. Bureau of the Census. June (1971)
23. California Water Quality Control Board. Detergent Report. State of California. Sacramento, California. (1965)
24. ARCO Chemical Company. Description of Process for Manufacture of Soft Detergent Alkylate. Glenolden, Pennsylvania.
25. Chemical Engineers Handbook. McGraw Hill Company. 4th Edition. (1963)

26. Chemiton Corp. Oleum Sulfonation Process Equipment. Brochure. Seattle Washington. (1968)
27. Chemithon Corp. S03 Detergent Process Equipment. Brochure. Seattle, Washington. (1968)
28. Chemical Week. 1973 Buyers' Guide Issue. McGraw Hill. October 25 (1972)
29. Cross, C. F. and Dreyfuc, C. Low Temperature Catalytic Alcoholysis. British Patent 125,153. (1919)
30. Cutler and Davis. Detergency, Theory and Test Methods. 1st Edition, part 1. Mafcel Dekker, Inc., N. Y. (1972)
31. Cyrus, William Rice & Company. The Cost of Clean Water and its Economic Impact. Projected Waste Water Treatment Costs in the Organic Chemicals Industry. Volume IV. U. S. Dept. Of Interior, Federal Water Pollution Control Administration. Washington, D. C. January 10 (1969)
32. Davidson, A. Detergents Powders via New Process. Soaps, Cosmetics, Chemical Specialties, pp 27-42. August, (1972)
33. Doss. Properties of Fats, Fatty Oils, Waxes, Fatty Acids and Salts. The Texas Company. (1952)
34. Dreger, E. E. Low Temperature Catalytic Alcoholysis. U. S. Patent 2,383,596. (1945)
35. Dugan, Patrick R. Biochemical Ecology of Water Pollution. Plenum Press, N. Y. (1972)
36. Dun & Bradstreet, Inc. A Study of Pollution Control Practices in Manufacturing Industries. Part I: Water Pollution Control. Research Services Dept. Dun & Bradstreet. June (1971)
37. Eckey, E. W. Hydrolysis. Encyclopedia of Chemical Technology. Vol. 5. Interscience Publishers. (1950)
38. Eckey, E. W. Hydrolysis. U. S. Patent 2,378,005. (1945)
39. Eckey, E. W. Vegetable Fats and Oils. ACS Monograph 123. (1954)
40. E. F. Eldridge. Industrial Waste Treatment Practice Mc Graw Hill, New York (1942)

41. Emmett, P. H. Physical Organic Chemistry. John Wiley & Sons. (1940)
42. Fieser, Louis R. and Mary. Advanced Organic Chemistry. Reinhold Publishing Company, New York.
43. Fieser, Louis F. and Ruth. Steroid Chemistry. Reinhold Publishing Company, New York.
44. Handbook of Applied Hydraulics. Mc Graw Hill, New York. (1952)
45. Hoffman, E. L. and Quigley, Ralph E. Flotation of Oily Wastes. Proceeding of 21st Industrial Waste Conference, Purdue University, Lafayette, Indiana. pp 527. (1966)
46. Hovious, J. C. et al. Anaerobic Treatment of Synthetic Organic Wastes. For Office of Research and Monitoring, Environmental Protection Agency. Project No. 12020 DIS. January (1972)
47. Industrial Engineering Handbook. Equipment and Facilities. 3rd Edition, Section II, pp 26-115. H. B. Maynard, Ltd. (1971)
48. Jamieson, Z. Vegetable Fats and Oils. ACS Monograph 58. (1943)
49. Kaempfe, G. Acidolysis of Glycerides. pp 1009. Farber - Zeitung 40. (1935)
50. Karrer, P. Organic Chemistry. Nordeman Company, New York. (1938)
51. Lewkowitsch. Chemical Technology and Analysis of Oils, Fats and Waxes. Volume II. (1922)
52. Lohr, J. W. Alcohol Sulphates from Alcohols and Undiluted Sulfur Trioxide. Andrew Jergens Company. U. S. Patent 3,232, 976 (1966)
53. Marquis, D. M. et al. The Production of Alpha-Olefin Sulfonates. Hydrocarbon Processing 47, no. 3, pp 109. Chevron Research Company. (1968)
54. McCutcheon, John W. Detergent Equipment and Processes. Detergent Age. J-8542, pp 1-20. (1973)
55. Meade, E. M. and Kroch, F. H. Low Temperature Catalytic Alcoholysis - Hydrolysis. British Patent 566,324. (1944)

56. Mills, V. Continuous Countercurrent Hydrolysis of Fats. Procter & Gamble. U. S. Patent 2,156,863 (1939)
57. Milwidsky, A. Practical Detergent Analyses. Pergamon Press. (1970)
58. Motl, C. W. Sulfonation at Low Pressures Using Undiluted Sulfor Trioxide. Procter & Gamble. U. S. Patent 3,248,413. (1966)
59. Morris, R. L. Process Plant for Sulfation of Alpha Olefins. Procter & Gamble Company. U. S. Patent 3,234,258. (1966)
60. National Technical Advisory Commission. Water Quality Criteria. Secretary of the Interior, Federal Water Pollution Control Administration, Washington, D.C. Government Printing Office. April (1968)
61. Pattison, E. Scott. Fatty Acids and Their Industrial Application. Marcel Dekker, Inc., New York (1968)
62. Potts, R. H. and Mc Bride, G. W. Continuous Hydrolysis Process of Colgate - Emery Companies. Chemical Engineering. (1950)
63. Projected Waste Water Treatment Costs in the Organic Chemicals Industry (updated). Datagraphics, Inc., Pittsburgh, Pennsylvania. July (1971)
64. Industrial Wastes: Their Disposal and Treatment. Rheinhold Publishing Corp., New York.
65. Sharples Division of Pennwalt Company. Sharples Continuous Soap Process. Brochure. Pennwalt Company, Warminster, Pennsylvania. April (1972)
66. Smith, Curtis W. Acrolein: Derivatives of Glycerol-aldehyde. John Wiley & Sons, New York. (1962)
67. Tashen, Edward S. and Booman, Keith A. Biodegradability and Treatment of Alkylphenol Ethoxylates - A Class of Nonionic Surfactants. Proceedings of the 22nd Industrial Waste Conference. pp 211. Purdue University, Lafayette, Indiana. (1967)



68. Todd, David Keith. The Water Encyclopedia. Water Information Center, Port Washington, N.Y. (1970)
69. Texas Division, The Dow Chemical Company. Treatment of Waste Water from the Production of Polyhydric Organics. For Office of Research and Monitoring Environmental Protection Agency. Project no. 12020 EEQ. October (1971)
70. Tyschbinek, G. Alcohol Esterification with Chlorosulfonic Acid. U.S. Patent 2,931,822. (1960)

## SECTION XIV

### GLOSSARY

ABS - An abbreviation applied to a family of closely related branched side-chain benzene compounds formerly used as surfactants in household detergents. ABS is an acronym for alkyl benzene sulfonate.

Act - The Federal Water Pollution Control Act Amendments of 1972, Public Law 92-500.

Aerobic - Growing only in air or free oxygen.

Aerobic Bacteria - Bacteria which require the presence of free (dissolved or molecular) oxygen for their metabolic processes. Oxygen in chemical combination will not support aerobic organisms.

Alkalinity - A quantitative measure of the capacity of liquids or suspensions to neutralize strong acids or to resist the establishment of acidic conditions. Alkalinity results from the presence of bicarbonates, carbonates, hydroxides, volatile acids, salts and occasionally borates, terms of the concentration of calcium carbonate that would have an equivalent capacity to neutralize strong acids.

Amalgamator - A large horizontal mixer used to blend perfume, dyes, fillers (titanium dioxide for whitening), and other materials in the manufacture of soap.

Anaerobic Bacteria - Bacteria that do not require the presence of free or dissolved oxygen for metabolism. Strict anaerobes are hindered or completely blocked by the presence of dissolved oxygen and in some cases by the presence of highly oxidized substances such as sodium nitrate, nitrites, and perhaps sulfates. Facultative anaerobes can be active in the presence of dissolved oxygen but do not require its presence. See also aerobic bacteria.

Anaerobic Decomposition - Reduction of the net energy level and change in chemical composition of organic matter caused by microorganisms in an anaerobic environment.

Antioxidants - Phenolic and amino compounds which inhibit oxidation of organic compounds.

Atmosphere - Unit of pressure. One atmosphere is normal atmosphere pressure.

Barometric Condenser - A system of both chilling vapors into the liquid state from a gaseous state and reducing flowing down a vertical pipe with considerable velocity. Identical to the laboratory aspirator, which depends upon the Venturi effect to create a vacuum.

Battery Limits - In considering plant construction and costs, an arbitrary boundary between essential process units and supporting facilities. Customarily within battery limits are reactors, stills, mixers, driers, and fabricators. Usually outside battery limits are power plants, cooling towers, sewage and water treatment, raw material and product storage, laboratory and office buildings and roads.

Best Available Demonstrated Control Technology (BADCT) - Treatment required for new sources as defined by Section 306 (a) (2) of the Act. Level III.

Treatment required by July 1, 1983 for industrial discharges to surface waters as defined by Section 301 (b) (2) (A) of the Act. Level II.

Best Practicable Control Technology Currently Available (BPCTCA) - Treatment required by July 1, 1977 for industrial discharges to surface waters as defined by Section 301 (b) (1) (A) of the Act.

Biological Cooling Tower - A cooling tower which is seeded with microorganisms and fed with nutrients in which biological degradation of organics occurs.

Biological Oxidation - The process whereby, through the activity of living organisms in an aerobic environment, organic matter is converted to more biologically stable matter.

Biological Stabilization - Reduction in the net energy level of organic matter as a result of the metabolic activity of organisms.

Biological Treatment - Organic waste treatment in which bacteria and/or biochemical action is intensified under controlled conditions.

Blowing Tower - See spray tower.

BOD5 - Biochemical oxygen demand. An indirect measure of the concentration of biologically degradable material present in organic wastes. It is the amount of free oxygen utilized by aerobic organisms when allowed to attack the organic matter in an aerobically maintained environment at a specified temperature (20°C) for a specific time period (five days). It is expressed in milligrams of oxygen utilized per liter of liquid waste volume (mg/l) or in milligrams of oxygen per kilogram of solids present (mg/kg=ppm=parts per million parts).

Builders - Inorganic salts (usually) which augment the cleansing or dirt-suspending power of a soap or detergent; i.e., sodium silicate, sodium carbonate, carboxy methyl cellulose, phosphates, etc.

Capital Costs - Financial charges which are computed as the control. The cost of capital is based upon a weighted average of the separate costs of debt and equity.

Caustic - Sodium hydroxide, caustic soda.

Changes - Those separate and identifiable steps taken in the manufacture of kettle boiling soap.

Chemical Oxidation - Oxidation of organic substances without benefit of living organisms. Examples are by thermal combustion or by oxidizing agents such as chlorine.

Clay - Alumino silicate minerals.

Closed Soap - That single phase of soap and water having a creamy consistency while in the hot, agitated state.

COD - Chemical Oxygen Demand. An indirect measure of the biochemical load exerted on the oxygen assets of a body of water when organic wastes are introduced into the water.

Cold Frame Soap - A type of soap produced by solidification by cooling and slicing into bars.

Condensate - The product resulting from a vapor condensing.

Cooling Water Blowdown - Whenever cooling water is reused and run over atmospheric contactors (in turn cooled by ambient air) there is a buildup of contaminants. Periodically it is necessary to dilute them or treat the cooling water to "blow down" or rid the system of the concentrated contaminants.

Crutcher - A cylindrical vessel of 681 - 2270 kg (1500 - 5000 lb) capacity in which soap or synthetic surfactants are mixed with builders prior to drying. It is often steam jacketed.

De-aerator - A piece of equipment for removing air dissolved or suspended in a fluid.

Detergent - Technically, any cleaning agent, including ordinary soap, the new "synthetic" granules and liquids, many alkaline materials, solvent, or even sand when used for scrubbing, whether used in the home or in industry. In popular speech, the term "detergent" is generally applied to packaged cleaning products based on a surface active ingredient such as ABS or LAS. Its cleaning power is retained in hard water, contrary to the performance of soap.

Dissolved Oxygen - The oxygen dissolved in sewage, water, or other liquid, usually expressed as milligrams per liter or as per cent of saturation.

Effluent - The outflow of a sewer; a waste waterstream from a manufacturing process or plant.

Evaporator - A unit in which liquids are converted to gas.

Fat - Glycerol esters of long chain fatty acids of animal or vegetable origin.

Fat Refining - Purification of fats by treatment with clay, caustic, etc.

Fat Splitting - Various processes for hydrolysis of fatty triglycerides to fatty acids and glycerine.

Fatty Acid - Naturally occurring straight chain carboxylic acids which usually occur as triglyceride esters (fats).

Fatty Oil - Triglycerides which are liquid at room temperature.

Fitting Change - Also called pitching or finishing change, is the final step in soap making in which clear water is mixed with the soap to separate the neat soap from the nigre.

Foots - The residue of refining fats or oils which contain color bodies, insolubles, suspended matter, etc.

Full Boil Process - Soap making where the neat soap is completed in the kettle and the by-product glycerine drawn off.

Heels - The residue remaining from any processing unit after drawing.

Killing Change - The first step in soap manufacture where fresh fat is brought into contact with a lye solution. The start of the saponification process.

LAS - A new surfactant in which a straight chain hydrocarbon has been joined to the benzene ring. It has a high rate of biodegradability.

Low Grade Fatty Acids - These are contaminated fatty acids derived from recovery of scrap, acidification of nigre, and contaminated fatty acid raw materials.

Mazzoni Process - A proprietary process for manufacture of soap.

mg/l - Milligrams per liter.

Neat Soap - An intermediate, completely saponified and purified soap containing about 20 - 30 percent water, ready for final formulation into finished product.

New Source - Any building, structure, facility or installation from which there is or may be a discharge of pollutants and whose construction is commenced after the publication of the guidelines.

Nigre - The bottom layer which separates out in the last washing step of kettle boiling soap which contains the impurities leading to poor color, odor, etc. Often contains 20 - 25 percent of the kettle contents at that stage of the soap making and possesses a soap content of 30 - 40 percent. The nigre can be concentrated and salted out to yield a low grade colored soap for sale.

No Discharge of Pollutants - No net increase (or detectable gross concentration if the situation dictates) of any parameter designated as a pollutant to the accuracy that can be determined from the designated analytical methods.

Oil - Fats found in liquid form at room temperature. Glycerol esters of long chain fatty acids.

Oleum - A solution of SO<sub>3</sub> in sulfuric acid.

Operations and Maintenance Costs - Those required to operate and maintain pollution abatement equipment. They include labor, material, insurance, taxes, solid waste disposal, etc.

pH - a measure of the relative acidity or alkalinity of water. A pH of 7.0 indicates a neutral condition. A greater pH indicates alkalinity and a lower pH indicates acidity. A one unit change in pH indicates a tenfold change in acidity and alkalinity.

Phenol - Class of cyclic organic derivatives with the basic formula  $C_6H_5OH$ .

Plodder - A powerful homogenizer which resembles a sausage grinder in design; used for the final processing of bar soap wherein the occluded air is removed (under partial vacuum) and the individual soap particles melded into one continuous homogenous whole prior to being cut up into bar stock.

Pollution - The presence in a body of water (or soil or air) of substances of such character and in such quantities that the natural quality of the body of water (or soil or air) is degraded to a point where the water is rendered useless or offensive to the senses of sight, taste or smell. Contamination may accompany pollution. In general, a public health hazard is created, but in some cases only economy or esthetics are involved as when waste salt brines contaminate surface waters or when foul odors pollute the air.

Pretreatment - Treatment provided prior to discharge to a publicly owned treatment works.

Process Water - In the manufacture of soap and detergent, all waters that come into direct contact with the raw materials, intermediate products, final products or contaminated waters or air.

Refractory BOD5- Organic substances which are slowly or incompletely degraded by microorganisms.

Saponification - The hydrolysis of an ester into its corresponding alcohol and soap.

Secondary Treatment - Biological treatment provided beyond primary clarification, usually aerobic activated sludge, trickling filters or lagoon systems.

Semi-boil Process - That soap making process wherein the exact (stoichiometric) amount of caustic is added to fat for saponification, and the soap is then run off into frames or further processed without the benefit of removal of by-product glycerine.

Sewage - Water after it has been fouled by various uses. From the standpoint of source it may be a combination of the liquid or water-carried wastes from residences, office buildings and institutions together with those from industrial and agricultural establishments, and with such ground-water, surface water and storm water as may be present.

Sewer Lyes - Waste sodium hydroxide from reclaiming of scrap soap.

Silicates - A chemical compound containing silicon, oxygen, and one or more metals. In soaps and detergents, sodium silicates are added to provide alkalinity and corrosion protection.

Soap Boiling - The process of heating a mixture of fats/oils with caustic solution until the fatty ester is split and the alkaline metal salt formed, glycerine being released in the process. The step where saponification takes place.

Soda Ash - Sodium carbonate.

Spray Drying Tower - A large vessel in which solids in solution or suspension are dried by falling through hot gas.

Stabilizers - An additive which gives physical and/or chemical stability to a formulation.

Still - A distillation apparatus.

Strong Change - That step in the soap making process where virgin, strong lye is added to the already saponified fat to finally complete saponification of remnants of fat.

Surface Waters - Navigable waters; the waters of the U.S. including the territorial seas.

Sweet Water - By-product aqueous glycerine from soap manufacture.

Synthetic Detergent - Chemically tailored cleaning agents soluble in water or other solvents. Originally developed as soap substitutes. Because they do not form insoluble precipitates, they are especially valuable in hard water. They are generally combinations of surface active agents and complex phosphates to enhance detergency.

TDS - Total dissolved solids.



METRIC UNITS  
CONVERSION TABLE

MULTIPLY (ENGLISH UNITS)		by	TO OBTAIN (METRIC UNITS)	
ENGLISH UNIT	ABBREVIATION	CONVERSION	ABBREVIATION	METRIC UNIT
acre	ac	0.405	ha	hectares
acre - feet	ac ft	1233.5	cu m	cubic meters
British Thermal Unit	BTU	0.252	kg cal	kilogram-calories
British Thermal Unit/pound	BTU/lb	0.555	kg cal/kg	kilogram calories/ kilogram
cubic feet/minute	cfm	0.028	cu m/min	cubic meters/minute
cubic feet/second	cfs	1.7	cu m/min	cubic meters/minute
cubic feet	cu ft	0.028	cu m	cubic meters
cubic feet	cu ft	28.32	l	liters
cubic inches	cu in	16.39	cu cm	cubic centimeters
degree Fahrenheit	°F	0.555 (°F-32)*	°C	degree Centigrade
feet	ft	0.3048	m	meters
gallon	gal	3.785	l	liters
gallon/minute	gpm	0.0631	l/sec	liters/second
horsepower	hp	0.7457	kw	kilowatts
inches	in	2.54	cm	centimeters
inches of mercury	in Hg	0.03342	atm	atmospheres
pounds	lb	0.454	kg	kilograms
million gallons/day	mgd	3,785	cu m/day	cubic meters/day
mile	mi	1.609	km	kilometer
pound/square inch (gauge)	psig	(0.06805 psig +1)*	atm	atmospheres (absolute)
square feet	sq ft	0.0929	sq m	square meters
square inches	sq in	6.452	sq cm	square centimeters
tons (short)	ton	0.907	kkg	metric tons (1000 kilograms)
yard	yd	0.9144	m	meters

\*Actual conversion, not a multiplier