

Biosolids Technology Fact Sheet

Heat Drying

DESCRIPTION

Heat drying, in which heat from direct or indirect dryers is used to evaporate water from wastewater solids, is one of several methods that can be used to reduce the volume and improve the quality of wastewater biosolids. A major advantage of heat drying versus other biosolids improvement methods, however, is that heat drying is ideal for producing Class A biosolids.

Class A biosolids, as defined in 40 CFR Part 503, are biosolids that have met “the highest quality” pathogen reduction requirements confirmed by analytical testing and/or the use of a Process to Further Reduce Pathogens (PFRP) as defined in 40 CFR Part 257. One advantage of Class A biosolids is that they are approved for unrestricted use. For example, Class A biosolids that also meet appropriate metals limits and vector attraction reduction requirements can be sold or given away for residential use, such as for use on lawns and home gardens. They can also be land-applied in public areas without restriction in addition to use as an agricultural amendment. The pellets formed from the heat-drying process have been successfully marketed to a wide range of

users for many years. They can be directly applied to agricultural fields, lawns, etc. or mixed with other ingredients prior to application.

APPLICABILITY

Heat drying is an effective biosolids management option for many facilities that desire to reduce biosolids volume while also producing an end-product that can be beneficially reused. For example, the Milwaukee Metropolitan Sewage District (MMSD) has been heat-drying wastewater solids and marketing the end-product as a fertilizer since the 1920s (USEPA 1979). The technology has gained popularity since the mid-1980s, as many large urban wastewater solids generators, especially on the east coast, have shifted from ocean disposal to land-based, beneficial use of biosolids. Most of the new wastewater solids processing facilities use direct rotary dryers. Table 1 presents a representative list of facilities that heat-dry wastewater solids.

Table 1.
Representative Wastewater Solids Dryers in the United States

Location	Type of Dryer	Type of Biosolids Dried
Milwaukee, WI	Direct, rotary	Blend of raw secondary with digested primary
Baltimore, MD (Patapsco)	Direct, rotary	Blend of raw primary with secondary
North Andover, MA	Direct, rotary	Anaerobically digested
Newport, TN	Indirect, rotary chamber	Anaerobically digested
Sacramento, CA	Direct, rotary	Anaerobically digested
Ocean County, NJ	Direct, rotary	Anaerobically digested
Waco, TX	Direct, rotary	Anaerobically digested
New York City, NY	Direct, rotary	Anaerobically digested
Amsterdam, NY	Indirect, disc	Anaerobically digested

Sources: Shimp et al. 2000; Pepperman 2005.



Used by permission of CH2M Hill, Inc.

Figure 1. Biosolids Dried Product Distribution Center.

Heat drying is applicable in both urban and suburban settings because it requires a relatively small amount of land and facility design allows process air to be captured for treatment. Markets for dried products are generally more prevalent in suburban and rural areas than in urban settings. However, because heat drying reduces the volume of the solids to such a great extent, transport of the end-product from urban areas to rural markets is usually economical. Heat drying is also becoming more cost-effective even for small systems (< 20 dry tons/day), particularly with indirect drying systems. For example, recent changes in the regulations in Texas over the past several years have made it harder to find areas on which to land-apply Class B biosolids. As urbanization spreads outward from larger communities, close-in farms where Class B biosolids can be land-applied are being developed, leaving only the farms farther out. With the rising costs of fuel, communities are turning to heat dryers to produce a Class A biosolids product to facilitate transport and enhance its value.

The physical characteristics of most wastewater solids allow for successful drying. But the facilities most likely to find heat drying feasible include those that have the following characteristics:

- Produce 10 or more dry tons of solids per day.
- Dewater up to 25 percent solids or greater.
- Produce digested solids (heat drying of raw wastewater solids tends to produce a more odorous product, thus reducing its marketability).
- Produce high-quality solids with respect to metals content.
- Are located in an area where landfilling, incineration, and land application of Class B biosolids are expensive or not feasible.

Although these characteristics might make specific facilities better candidates for heat drying, some of these characteristics also affect design decisions for construction of the heat-drying operations. These factors are discussed in the “Design Criteria” section addressed later.

ADVANTAGES AND DISADVANTAGES

There are both advantages and disadvantages to using heat drying to stabilize wastewater solids. Several of these advantages and disadvantages are summarized below.

Advantages

- Requires a relatively small footprint compared with other stabilization processes, such as composting, alkaline stabilization, and air drying/long term storage.
- Can be designed to accept a variety of feed material characteristics.
- Greatly reduces the volume of material that needs to be transported. The typical heat-dried product is at least 90 percent solids, compared to 15 to 30 percent solids commonly produced by mechanical dewatering operations. This feature is particularly important for major urban areas, where the end-product might need to be transported for considerable distances for use or marketing.
- Reduces traffic into and out of a facility. The number of trucks required to remove material is reduced because of the smaller volume of the final biosolids product. In addition, no additives or amendments need to be transported into the facility.
- Generates a readily marketable product.

Disadvantages

- Requires a substantial capital investment. Capital costs often are weighed against the long-term financial return that can be realized by the sale of the heat-dried pellets.
- Requires a large amount of energy. Heat-drying systems can require 1,400–1,700 British thermal units per pound of water evaporated. This makes heat drying less energy-efficient per pound of final material than other beneficial reuse methods, such as composting and land application. (Sapienza and Bauer 2005). In some cases, this can be at least partially offset through the use of on-site energy sources. For example, some facilities use gas from their anaerobic digesters to fuel the heat-drying units. Wood chips have also been

used as a fuel source to produce the hot gases used in direct dryers. Recycling of these gases also reduces fuel costs.

- Generates dust that can affect plant workers and neighbors in the local community and must be controlled to avoid problems during storage and transport of the product. The health effects of the dust are similar to those caused by exposure to other sources of dust and primarily affect lung function. Controls are available to address dust concerns. Dust control is further discussed in the “System Design Considerations” section below.
- Creates an explosive hazard from dust generated in the drying process. (Sieger and Burrowes (2006)) Dryer installations have experienced fires, deflagrations, and explosions. Much of the recent work in thermal drying systems has been focused on enhancing their safety. (See discussions of thermal drying safety in the “Design Criteria” and “Performance” sections below.)
- Requires systems that are relatively complex in comparison with other solids-processing systems and need skilled labor for operation and maintenance.
- Can produce nuisance odors that could negatively affect community acceptance of the process. Sapienza and Bauer (2005) note that odor was “probably the single most detrimental impact from thermal drying plants.” For example, the Morris Forman Wastewater Treatment Plant in Louisville, Kentucky, struggled with odor control in its heat-drying process for a decade. However, in 2003 the plant completed an upgrade to its solids-handling process that replaced an odor-causing low-pressure oxidation system with a system that includes anaerobic digestion and blending of biosolids with secondary solids prior to dewatering and drying. The new design not only significantly reduced odors emitted to the atmosphere from the heat-drying process, but it also reduced the volume of solid waste produced at the plant and the subsequent landfill charges that go along with solid waste disposal. In addition, methane produced in the anaerobic digesters can be

used to fuel the heat dryers, thereby reducing plant operating costs.

- Results in an end-product that might have properties (such as offensive odor) that affect its value and marketability. Sapienza and Bauer (2005), however, note that the most current designs for heat-drying operations incorporate recirculation of dryer exhaust gas and the use of regenerative thermal oxidizers and other techniques to reduce the odor of the final exhaust gas. Therefore, the authors conclude that odorous emissions are no longer a significant problem for heat drying facilities. (See discussion on “End-Product Characteristics” below).

DESIGN CRITERIA

Operators and planners should consider three basic questions when selecting or designing a heat-drying system:

1. What characteristics are desirable in my end-product?
2. How could the heat-drying system be configured to achieve my desired end-product, ensure efficient operation, and meet safety standards?
3. What type of dryer is best suited for my specific system?

The following discussions provide background information that should enable treatment plant operators and planners to answer these questions and identify an appropriate heat-drying system for their needs.

End-Product Characteristics

Heat-drying systems are typically designed to produce Class A biosolids. Although Class B biosolids can be produced using a heat-drying system, the lower market value of a Class B product typically does not justify the energy and cost required to run the system. The regulatory requirements for a heat-drying process to be considered a Process to Significantly Reduce Pathogens for the production of Class A biosolids are discussed later in the “System Design Considerations” section.

Although federal regulations allow for Class A biosolids that also meet the metal limits and vector attraction reduction requirements to be distributed to the public for unrestricted use, not all Class A biosolids have the same market value to consumers. The following list describes several biosolids end-product characteristics that can be controlled to improve product marketability.

- **Odors.** It is preferable that the pellets be free of offensive odors. Undigested solids tend to create more odorous pellets than those made from digested or waste-activated solids (Dolak et al. 2001). Odors can increase if the pellets become wet, which can happen from condensation during cooling or through other mechanisms. The best way to reduce odors in the finished product is to continue to digest prior to dewatering and drying (NBP 2005). In addition, the end-product must be properly stored to ensure that it is not exposed to moisture before use. Exposure to significant moisture presents a potential for anaerobic decomposition (leading to odors).

Undigested biosolids led to odor problems at the Hagerstown, Maryland, pelletizing plant. The plant mixed an undigested primary sludge (typically high in odor) with waste activated secondary sludge prior to drying the material. Influent to the plant also contained waste from local dairy processors, which added a pungent odor to the primary sludge. When the product was first dried, there was no odor to the pellets. However, after the pellets cooled, they released a strong offensive odor (R. Pepperman, personal communications, 2005). The facility eventually added an odor-masking compound to make the pellets more marketable to the agricultural community. Further information on the control of odors in biosolids (related to more than heat drying) can be obtained from the fact sheet *Odor Control in Biosolids Management* (USEPA 2002).

- **Nutrient content.** One of the main reasons that heat-dried biosolids can be sold and used as fertilizer is their nutrient content. Heat-dried biosolids pellets contain up to 6 percent nitrogen, up to 5 percent phosphorus, and a trace of potassium. Sufficient nutrients must

be present in the biosolids to warrant the costs associated with transporting and applying them as fertilizer. A reliable sampling program must be established to determine the nutrient content, and this information should be provided to potential users (NBP 2005).

- **Mechanical durability.** It is important to ensure that the product will maintain its form through bagging, conveyance, handling, and storage. Pellets that are not within the standard range for mechanical durability may crumble during handling; therefore, they may not be acceptable even if they have sufficient nutrient content.
- **Particle size distribution.** Pellets produced by heat-drying wastewater solids range in size from 1 to 4 millimeters and are angular in shape. Screening and sizing abrade the pellets into a more spherical shape. Irregular particle sizes can result in larger particles settling faster than smaller ones. Some users (such as fertilizer blenders) must ensure that products remain well mixed throughout shipment to their customers. End users may associate irregular pellet sizes with an inferior product.
- **Moisture content.** Too much moisture in the pellets can cause odor problems and might also cause the pellets to smolder. Adequate cooling before the pellets are stored or transported will reduce the potential for odor and smoldering, and therefore this step should be included as part of the facility's biosolids process (NBP 2005).
- **Dust content.** Dust from pellets can be problematic for several reasons. First, dust can be an explosion hazard. Second, dust might cause human health problems. And third, some potential end-users may not accept dusty pellets; since many potential users of biosolids pellets find excessive dust unacceptable or at least characteristic of an inferior product (NBP 2005). Dust can be generated because the pellets were not sufficiently dried and hardened during heat-drying or because the pellets were not otherwise processed to minimize their potential to cause dust. Sapienza and Bauer (2005) note that, typically, the harder the heat-dried material, the less potential there is to generate dust.

Repeated handling of some pellets during storage and/or transport, however, can result in dust generation, which may be a concern for fertilizer blenders who must comply with air emission requirements. Coating pellets with vegetable oil or paraffin minimizes dust production.

System Design Considerations

Once the planners determine the desired characteristics of the heat-dried biosolids end-product, they must design a system that can produce that end-product. The following items must be accounted for in the design process.

- **Characteristics of feed solids.** The moisture content of the feed solids partially dictates the required dryer capacity and affects decisions on appropriate conveyance technologies and the amount of previously dried material to be mixed with the feed solids. Many experts recommend that biosolids be digested prior to heat drying to minimize odors produced at the processing facility and in the final product. (See the discussion on odors under “End-Product Characteristics” above.) Mixing previously dried product into the feed solids will reduce the moisture content of the mixture and help to prevent the solids from sticking in the dryer. There are several options for mixing, including pug mills and paddle mixers.
- **Process dust control.** Dust control during the actual heat-drying process is important to protect worker health and safety, as well as to minimize the potential for fire and explosion. (See “Safety Considerations” later in this section.) Dust can be controlled by enclosing the drying system and using cyclone separators, wet scrubbers, or bag houses. Site-specific air modeling is recommended during the conceptual design of heat-drying facilities to determine the potential for dust migration off-site.

A process patented by Dutch company Grontmij Vandenbroek International has several innovations to reduce the potential for dust to become an explosive hazard. The process feed does not enter the dryer at the same location as

the dryer air, which keeps the solids from sticking and overdrying at the entrance to the process. The dryer uses the VADEB multi-pass system, which keeps the material from being over-dried in the dryer. Finally, the dried particles are entrained in exhaust air, from which they are separated by size. The under-sized particles go back into the process to be mixed with incoming solids, the oversized particles are correctly resized in a crusher, and the correctly sized particles go to storage. Most of the exhaust air is then recycled, while some is vented to the environment through an in-line afterburner.

- **Storage for feed solids and the finished product.** Control of dust and odor is necessary when storing both feed and dried biosolids. Feed solids can be stored in day bins, which are common in solids-processing facilities. However, special considerations must be made for storing the dried biosolids. High solids content can make the potential for dust formation high. Nitrogen or some other inert agent is usually injected into storage silos to reduce the fire hazard. Care also must be taken to ensure that the dried biosolids are stable, reducing the potential for odors. (See “Odors” discussion above.)
- **Compliance monitoring.** If Class A biosolids are to be produced, a system to monitor the heat-drying process must be incorporated to ensure (1) that the moisture content is 10 percent or lower and (2) that the temperature of the biosolids particles or the wet bulb temperature of the gas in contact with the biosolids exceeds 176 °F (80 °C). In addition, heat-dried biosolids must be tested for fecal coliform bacteria or *Salmonella* sp. at the last point before being used or disposed of (USEPA 1999).
- **Location of dewatering and drying systems.** The heat-drying system should be located near the dewatering system to cut down on biosolids handling and transport within the facility.
- **System capacity.** The heat-drying system must be sized to allow for required equipment maintenance. If a single system is implemented,

use of standby grinders, fuel pumps, an air compressor (if applicable), and dual sludge pumps should be provided, and this equipment should be in good working condition. A reasonable downtime for maintenance and repair based on data from comparable facilities is typically included in the design. A good rule of thumb is to provide storage or alternative handling for at least 3 days of peak solids production. Maximizing storage capacity (based on available land area and economics) increases program flexibility. Additional storage also enables a facility to store its finished product if market demand fluctuates or if weather conditions make transporting pellets off-site more hazardous.

- **Adequate space for screening equipment.** Depending on the type of dryer and intended end use of the product, additional processing, such as sizing, screening, coating, or pelletization, might be necessary. Sizing and screening equipment is used to sort out particles that do not meet an end user's specifications or to recycle unacceptable material back to the infeed—directly with small particles or after further processing (such as milling) for large particles. Adequate space for this type of equipment should be factored into any construction design.
- **Energy considerations.** As discussed above, heat dryers require a large amount of energy, and they are less energy-efficient per pound of final material than other beneficial reuse methods. Innovative designs, however, allow newer dryers to operate at lower temperatures than older dryers, and thus they require less energy. This has allowed some dryers to use low-energy waste streams as power sources. Moss and Sapienza (2005) indicate that direct dryers can use biogas, landfill gas, gas turbine exhausts, and wood-fired gasifiers as energy sources, while indirect systems can use these sources as well as steam or hot water generator exhaust, or waste heat from water circuits. For example, MMSD uses waste heat from turbine generators to power its sludge dryers (MMSD 2005). New England Fertilizer Company (NEFCO) designed, built, and is operating the Greater Lawrence, Massachu-

setts Sanitary District Biosolids Drying Facility, a direct rotary kiln dryer that uses digester gas as a fuel source. The system, which came online in 2002 at a cost of \$13 million, has a capacity of 38 dry tons of Class A biosolids/day and is estimated to save the District an estimated \$600,000 in operations costs annually relative to other drying options because of the alternative fuel source (NEFCO 2006). A second NEFCO installation in Palm Beach County, Florida, that can accommodate 600 wet tons/day will use 2,000 scfm of landfill gas as its fuel source and will use only natural gas as a backup. Hillsborough County, Florida, uses the biogas generated from a local landfill to operate the dryers.

- **Safety considerations.** Because of their high organic content, both the heat-drying end-product and the dust generated during production of the end-product are flammable, and precautions must be taken to design the heat-drying process, equipment, and storage to minimize the potential for explosion or fire. Various design modifications can be made to minimize the potential for fire or explosion, including minimizing dust through the use of cyclone separators, wet scrubbers, or bag houses; minimizing oxidation potential by using an inert gas; and minimizing combustion by cooling the end-product and ensuring that the end-product is not produced or stored near heat sources, such as dewatering processes. Sieger and Burrowes (2006) also indicate that in addition to inertization, other safety considerations include isolation, explosion suppression, explosion relief, and venting and extinguishing. Designers should work with the vendors to ensure that the various safety considerations in designing and implementing the system are well understood.

Types of Dryers

The most important feature of a heat-drying system is the dryer. Typically, the rest of the facility is designed around this integral piece of equipment. Dryers can be classified as direct, indirect, or other. Direct and indirect dryers typically have been most successful for drying wastewater solids.

Direct Dryers. In direct dryers, the wastewater solids come into contact with hot gases, which cause evaporation of moisture.

Direct dryers, which include rotary dryers (the most common dryers in use today, shown in Figure 2), flash dryers, spray dryers, the SWISS COMBI ecoDry process, and toroidal dryers, are most often the technology of choice when the product is intended to be marketed as an agricultural product.

Pellets from direct dryers are usually uniform in texture, size, and durability, and therefore they rarely require additional processing to make them marketable. Generally, the plant must mix processed solids (usually undersized fine particles) into the feed solids to raise the solids content of the feed mixture and avoid a condition referred to as the “sticky” or “plastic” phase. This phase

occurs in mixtures with between 40 and 60 percent solids, and it renders the material difficult to mix and move inside the dryer.

Indirect Dryers. In indirect dryers, the solids remain separated from the heating medium (usually thermal oil or steam) by metal walls, and the solids never come into direct contact with the heating medium. Moisture evaporates when the wastewater solids contact the metal surface heated by the hot medium. The heat transfer surface is composed of a series of hollow metal discs or paddles mounted on a rotating shaft, through which the heating medium flows. The rotating action of the shaft agitates the solids, improving heat transfer and facilitating the solids’ movement through the dryer. Mixing of previously dried material with feed solids is required in some indirect drying systems.

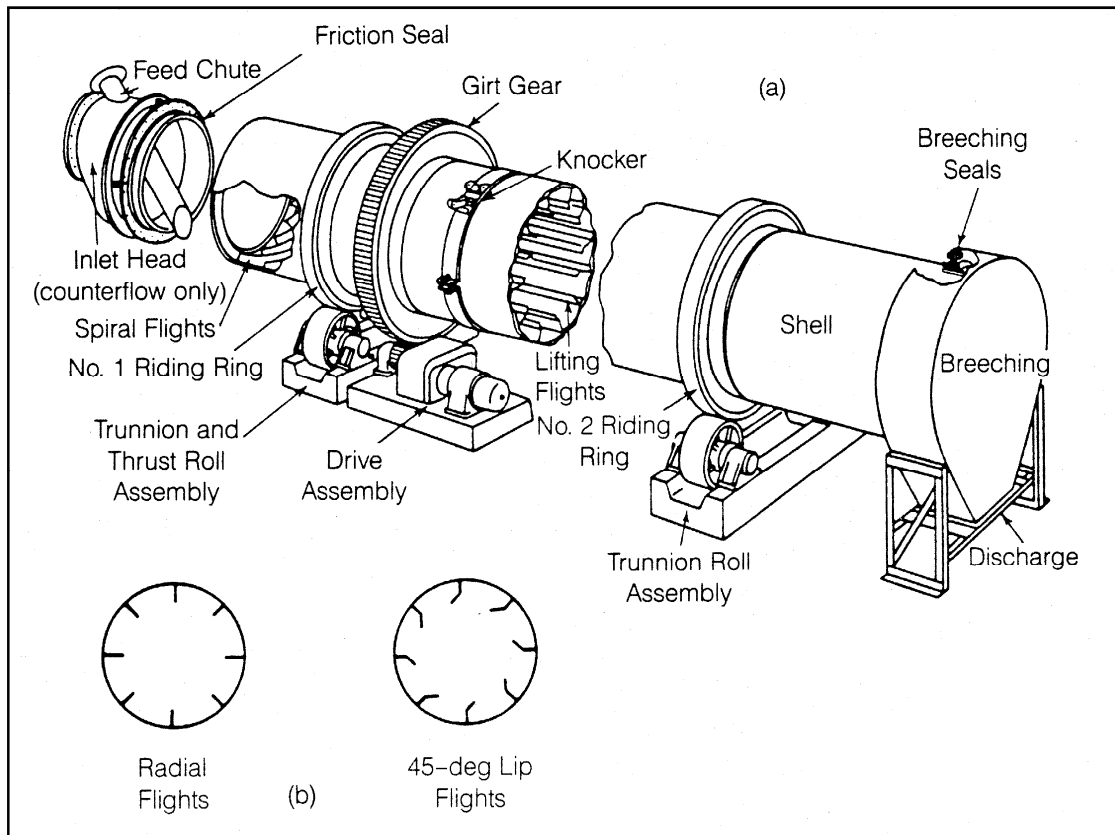

Source: WEF, 1992.

Figure 2. Rotary Dryer: (a) Isometric View and (b) Alternative Flight Arrangements.

Indirect dryers, which include steam dryers, hollow-flight dryers (Figure 3), and tray dryers, produce smaller quantities of noncondensable gas than direct dryers, which means that the process produces less odor and requires less odor control equipment. Indirect dryers usually have a higher thermal efficiency and are more suitable when pellets are to be used in energy production or combusted. Indirect dryers also produce less dust during the drying process and have a lower risk of explosion than direct dryers. However, the end-product of indirect dryers (the pelletized material) tends to be dustier than a dried product from a direct dryer, and therefore it is not as marketable to some users. Finally, indirect dryers often produce oversized pellets, which are not as desirable in the agricultural market (R. Pepperman, personal communication, 2005). Additional processing (such as granulation or compaction) might be required to increase the uniformity,

consistency, and durability of the product. Such processing can improve the marketability of the pellets from indirect drying facilities, but it also increases costs.

A comparison of direct and indirect dryers is presented in Table 2.

Table 2.
Comparison of Direct Versus Indirect Drying

Direct	Indirect
Dried solids recycling required.	Dried solids recycling sometimes required.
Many operating facilities in the United States.	Limited number of operating facilities in the United States; several successful operations in Europe.

Source: Summarized by Parsons 2005.

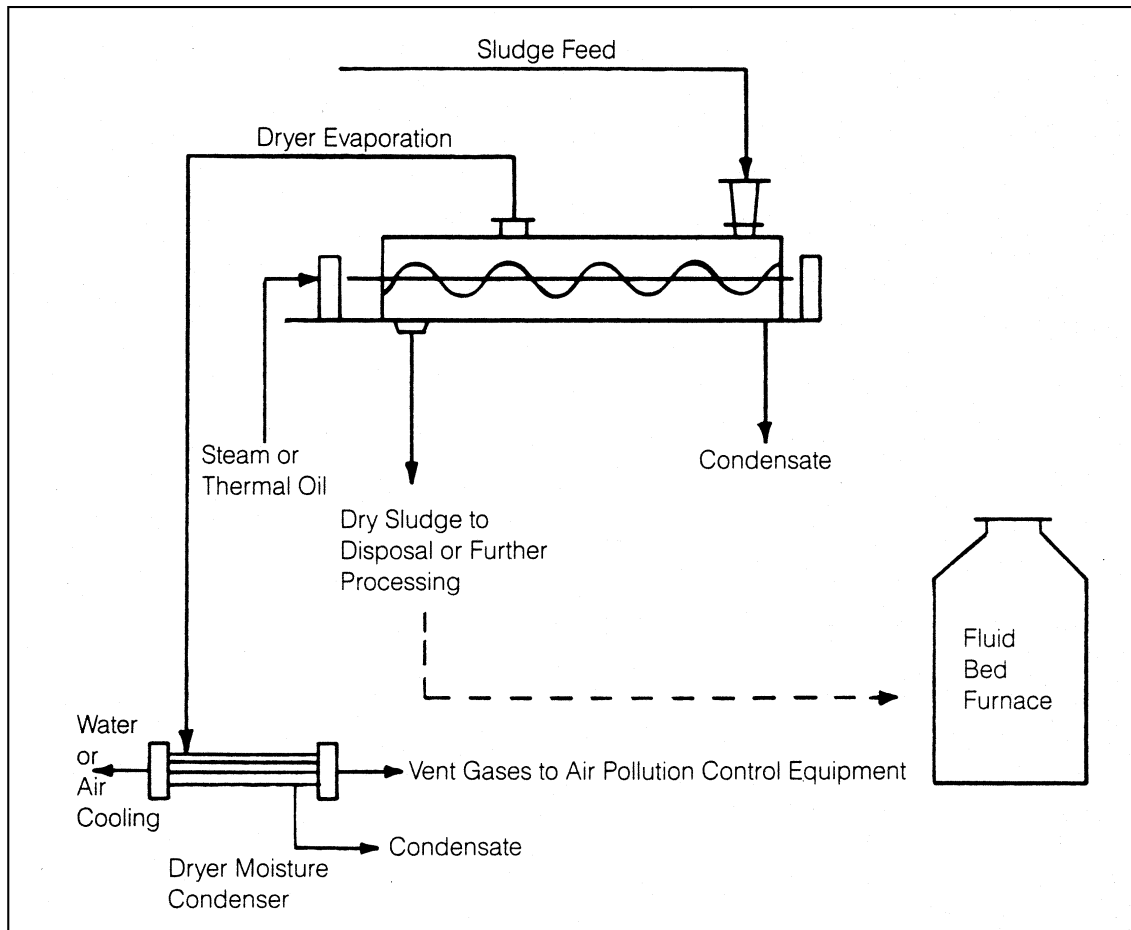

Source: WEF, 1992.

Figure 3. Flow Diagram of Hollow-Flight Dryer System.

Other Types of Dryers. Other types of dryers include those that use a combination of direct and indirect drying or use special carrier fluids. For example, the Jones Island Wastewater Treatment Plant in Milwaukee, Wisconsin, which has been in operation longer than any other facility using heat drying in the United States, uses a combination direct-indirect rotary system. Carver-Greenefield has patented a dryer that uses carrier oil. In this system, wastewater solids are mixed with the oil, and the mixture flows through a multi-effect evaporator, where moisture is removed. Although a number of Carver-Greenefield biosolids dryer facilities were constructed (including facilities for the Los Angeles County Sanitation District, the Ocean County [New Jersey] Utility Authority, and the Mercer County [New Jersey] Improvement Authority), none are currently operated. This system required considerable maintenance to operate reliably, and its working capacity was smaller than that indicated by the designer.

Microwave Dryers. Burch Biowave has developed a system that uses a high-efficiency, multi-mode microwave specifically designed to remove moisture and destroy pathogens. The process does not affect the nutrient content of the end-product and can produce Class A biosolids. A Burch Biowave system in Fredericktown, Ohio, began operations in 2004, and another is planned for Zanesville, Ohio.

Annual buyer's guides published by trade organizations such as the Water Environment Federation and the Solid Waste Association of North America are good sources of additional information on heat dryer manufacturers.

PERFORMANCE

Heat-drying technology is generally very reliable, and few facilities experience significant periods of unscheduled downtime. Nevertheless, some installations have experienced performance problems. Spontaneous heating in storage areas is a concern because of the organic matter content of pellets derived from wastewater solids, and improper product storage procedures and dust accumulation have caused fires in some locations.

The volatile solids content and temperature of the pellets also affect their explosion potential. Therefore, pellets must be cooled to avoid combustion in storage facilities. Most facilities blanket the pellets stored in storage silos with inert material (such as nitrogen) to lessen the explosion potential. Facilities can also monitor the silos using thermal sensors (to detect increases in temperature) or carbon monoxide monitors (to detect increases in carbon monoxide), both of which could indicate potential fire hazards (Sapienza and Bauer 2005).

The Occupational Safety and Health Administration (OSHA) issued a Hazard Information Bulletin in December 1995 that described required safety precautions for facilities that process, convey, or store dried biosolids. OSHA has outlined design criteria that help minimize and control explosion and fires connected with the organic dust from heat-dried biosolids. These criteria include venting systems to release any buildup of pressure within the drying vessels or storage areas, safely releasing gas from drying facilities, using non-conductive materials in areas of drying or product storage, reviewing all heat sources in and around heat-drying processes and storage areas, and ensuring that workers in these areas employ good housekeeping practices (OSHA 1995). Sapienza and Bauer (2005) also note that maintaining an oxygen-deficient atmosphere in the process components (dryer, solids separator, recirculation duct) can help to minimize this potential problem.



Used by permission of CH2M Hill, Inc.

Figure 4. Rotary Dryers, the Most Common Type Used for Drying Wastewater Solids.

Sieger and Burrowes (2006) also presented information on the safety and design of heat-drying systems.

OPERATION AND MAINTENANCE

Heat-drying systems are sometimes highly mechanized to maintain proper temperatures and inflow/outflow. Therefore, operation of such systems require skilled operators. Preventive maintenance is a necessary part of day-to-day operations. Routine cleaning helps to avoid corrosion caused by the properties of the solids. Multiple units are often used to avoid disruption to treatment works operation when units are not in service. All units should be in proper working order so they can be used if needed.

Several operating heat-drying systems report common problems, including pitting of conveyance equipment and dryer drums due to the abrasive nature of the wastewater solids, and scale formation on dryers and piping. Scale can be removed by washing with acid or high-pressure water jets. Mixing oil with the solids also helps to prevent scale formation.

COST

Capital and O&M costs for heat-drying facilities are typically high relative to other solids alternatives, such as land application and alkaline stabilization (Sapienza and Bauer 2005). It is difficult, however, to estimate the exact costs of heat-drying wastewater solids without design details such as the specific type of dryer, fuel source, and moisture content of the feed solids. Santa Barbara County, California, (2004) estimated that heat drying would cost from \$51 to \$58 per wet ton, depending on the availability of biogas or waste heat from co-generation facilities. These costs are based on an average biosolids solids content of 18 percent. Grace et al. (1994) compared the cost of direct versus indirect drying of approximately 35 dry metric tons of wastewater solids per day and estimated \$323 per dry ton for indirect drying and \$441 per dry ton for direct drying. These figures included capital costs of \$26.8 million for the indirect dryer versus \$37 million for the direct drying system.

Sapienza and Bauer (2005) report that historical costs for heat-drying equipment typically ranged between \$110,000 and \$180,000 per dry ton/day of solids processing capacity for facilities processing between 20 and 100 dry tons/day. Capital costs for the entire heat-drying operation, including buildings, site work, utilities, dewatered cake conveyance, product storage, performance testing, and so forth can be in the \$220,000–\$300,000 per ton per day range (Sapienza and Bauer, 2005). The city of Leesburg, Virginia, installed a direct rotary dryer system with an evaporative capacity of 2,000 kg/hr in 2001 as part of a biosolids management upgrade project. The project, which cost \$11.5 million, also included a screening building and a 350,000-gal sludge storage tank. The city chose an Andritz system in which hot gases are routed directly into the dryer instead of an alternative system with a heat exchanger because the Andritz system could start up and shut down more quickly. This feature was important because the city does not run the system constantly (S. Cawthron, City of Leesburg, personal communication, 2006).

Items that must be considered when estimating capital costs include

- Dewatering feed solids
- Feed solids mixing
- Dryer
- Conveyance to and from dryer
- Air emission (including odor and dust) control
- Product classification, screening, and/or pelletizing
- Product cooling prior to storage
- Product storage, including provisions for nitrogen blanketing

Sapienza and Bauer (2005) indicate that O&M costs for heat-drying facilities typically range from \$180 to \$300 per dry ton of material processed. These costs include costs for fuel, power, O&M labor, and maintenance materials and supplies. Costs for fuel can be a significant part of these costs and can range from 25 percent to 55 percent of the total O&M costs.

Typical O&M costs include

- Labor
- Auxiliary fuel
- Air emission control chemicals and maintenance
- Equipment maintenance
- Product transport
- Product marketing

Another facet of costs related to drying is the sale of the resulting product. Biosolid pellets from dryers are historically very marketable products. The factors that influence the price received for the pellets are nutrient content, particle size distribution, dust potential and mechanical durability (which are closely related), bulk density, moisture content, and odor.

Nutrient content usually has the greatest impact on the price because most buyers base their purchase on the amount of nitrogen in the pellets. Many facilities sell dried biosolids to users with the price based on the nitrogen content of the product. Current prices are typically around \$9 per metric ton (\$10 per ton) of material per percent nitrogen. Sapienza and Bauer (2005) report a range in value from \$0 to \$36 per metric ton (\$0 to \$40 per ton). As with many types of products, however, prices can fluctuate with the seasonal demands of users and in response to supply. The operation of several large dryers has recently increased supply and led to falling prices. Being able to store the products until supply is low might also help the bottom line. Producers that can hold the product until users are ready might net a higher price than those who move the product from the site every day regardless of price.

Although the sale of dried biosolids provides a welcome source of revenue to wastewater treatment plants to help offset O&M costs, it should be noted that selling the end-product typically does not completely offset heat-drying processing costs.

REFERENCES

Other related fact sheets:

Odor Control in Biosolids Management
EPA 832-F-00-067
September 2002

Centrifugal Thickening and Dewatering
EPA 832-F-00-053
September 2002

Belt Filter Press
EPA 832-F-00-057
September 2002

Other EPA fact sheets are available at the following Web address:
<http://www.epa.gov/owmitnet/mtbfact.htm>

Cawthron, S., City of Leesburg Wastewater Treatment Plant. 2006. Personal communication.

Dolak, I., S. Murthy, and T. Bauer. 2001. Impact of Upstream Processes on Heat-drying Technology. In *Proceedings of the Water Environment Federation, American Water Works Association and California Water Environment Association Specialty Conference, Biosolids 2001: Building Public Support*. Arlington, VA: Water Environment Federation.

Feindler, K.S., and C.A. Holley, 1994. *Method for Upgrading Thermally Dried Wastewater Solids into a Competitive Organic Fertilizer*. In *Proceedings for the Management of Water and Wastewater Solids for the 21st Century: A Global Perspective*. Alexandria, VA: Water Environment Federation.

Foess, G.W., D. Fredericks, and F. Coulter. 1993. Evaluation of Class A Residuals Stabilization Technologies for South Broward County, Florida. In *Proceedings of the Water Environment Federation 66th Annual Conference & Exposition, Sludge Management*. Arlington, VA: Water Environment Federation.

- Grace, N., G. Carr, and J. Finley. 1994. Direct Versus Indirect Thermal Drying of Biosolids: A Comparative Evaluation. In *Proceedings of the Water Environment Federation Specialty Conference, The Management of Water and Wastewater Solids for the 21st Century: A Global Perspective*. Arlington, VA: Water Environment Federation.
- Grontmij Vandenbroek. 2006. VADEB Thermal Kinetic Drying Technology. <<http://www.vadeb.nl>>. Accessed May 2006.
- Komline-Sanderson Engineering Corporation. 2000. Web site. <<http://www.komline.com>>. Accessed 2000.
- MMSD (Milwaukee Metropolitan Sewer District). 2005. 2020 Facilities Plan. <http://www.mmsd.com/wqi/docs/chapter_review_20051115041921.pdf>. Accessed June 2006.
- Moss, L., 2006. Personal communication.
- Moss, L., and F. Sapienza. 2005. Presented at Managing Biosolids: A Toolbox for Texas, hosted by the Water Environment Association of Texas, Austin, TX, August 2005.
- Murthy, S., H. Kim, C. Peot, L. McConnell, M. Strawn, T. Sadick, and I. Dolak. 2003. Evaluation of Odor Characteristics of Heat-Dried Biosolids Product. *Water Environment Research Foundation* 75(6): 523–31.
- NBP (National Biosolids Partnership). 2005. *National Manual of Good Practice for Biosolids*. January 2005.
- NEFCO (New England Fertilizer Company). 2006. Web site. <<http://www.nefcobiosolids.com/news.asp>>. Accessed May 2006.
- OSHA (U.S. Department of Labor, Occupational Health and Safety Administration). 1995. *OSHA Hazard Information Bulletin: Fire and Explosive Hazards Associated with Biosolids Derived Fuel (BDF) and Waste Water Treatment Plants*. Washington, DC: Occupational Health and Safety Administration.
- Pentecost, D.J. 2004. Biosolids 101: Understanding the Pathogen Classes. *Pollution Engineering* 36(8): 20–23
- Pepperman, R. 2005. Personal communication.
- Pepperman, R. 2006. Personal communication.
- Santa Barbara County, California. 2004. *Strategic County-Wide Biosolids Master Plan*. Prepared by CH2MHill.
- Sapienza, F., and T. Bauer. 2005. Thermal Drying of Wastewater Solids. Presented at WEFTEC 2005, Washington, DC.
- Shimp, G.F., J.M. Rowan, J.S. Carr. 2000. Continued Emergency of Heat-drying: A Technology Update. In *Proceedings of the 14th Annual Residuals and Biosolids Management Conference*. Arlington, VA: Water Environment Federation.
- Sieger, R.B., and P. Burrowes. 2006. The Key to a Successful Thermal Dryer System—Safety. Presented at Texas Water 2006, Austin, TX.
- USEPA (U.S. Environmental Protection Agency). 1979. *Process Design Manual for Sludge Treatment and Disposal*. Washington, DC: U.S. Environmental Protection Agency.
- USEPA (U.S. Environmental Protection Agency). 1993. Standards for the Use or Disposal of Sewage Sludge (Title 40 *Code of Federal Regulations* Part 503). Washington, DC: U.S. Environmental Protection Agency.
- USEPA (U.S. Environmental Protection Agency). 1999. *Biosolids Generation, Use and Disposal in the United States*. Washington, DC: U.S. Environmental Protection Agency.
- USEPA. (U.S. Environmental Protection Agency). 1999. *Environmental Regulations and Technology: Control of Pathogens and Vector Attraction in Sewage Sludge*. Washington, DC: U.S. Environmental Protection Agency.
- WEF (Water Environment Federation). 2000. *Milwaukee Metropolitan Sewerage District Continuing the Tradition of Milorganite®* p. 43-50. Biosolids Success Stories (CD). Alexandria, VA: Water Environment Federation.

WEF (Water Environment Federation). 1992.
*Design of Municipal Wastewater Treatment
Plants*. WEF Manual of Practice No. 8. Alex-
andria, VA: Water Environment Federation.

*The mention of trade names or commercial
products does not constitute endorsement or
recommendation for use by the U.S.
Environmental Protection Agency.*

ADDITIONAL INFORMATION

Synagro Corporation
Karl von Lindenberg
P.O. Box 9974
Baltimore, MD 21224

Milwaukee Metropolitan Sewerage
Paul Schlect
260 West Seeboth Street
Milwaukee, WI 53204-1446

New England Fertilizer Company
Virginia Grace
500 Victory Road
North Quincy, MA 02171

New York Organic Fertilizers Company
Peter Scorziello
1169 Oakpoint Avenue
The Bronx, NY 10474

New York Department of Environmental
Protection
Tom Murphy
96-05 Horace Harding Expressway
Corona, NY 11368

Office of Water
EPA 832-F-06-029
September 2006

For more information contact:
Municipal Technology Branch
U.S. Environmental Protection Agency
Mail Code 4204
1200 Pennsylvania Avenue, NW
Washington, DC 20460