

**UNITED STATES COURT OF APPEALS
FOR THE NINTH CIRCUIT**

ALASKA COMMUNITY ACTION ON TOXICS

Petitioner,

v.

UNITED STATES ENVIRONMENTAL
PROTECTION AGENCY, and ANDREW
WHEELER, Administrator, United States
Environmental Protection Agency,

Respondents.

No. _____

PETITION FOR REVIEW

Pursuant to the Toxic Substances Control Act, 15 U.S.C. § 2618, the Administrative Procedure Act, 5 U.S.C. §§ 701–706, and Rule 15 of the Federal Rules of Appellate Procedure, Alaska Community Action on Toxics hereby petitions for review of a final risk evaluation and order by Respondent United States Environmental Protection Agency (EPA), determining that the chemicals in the cyclic aliphatic bromide cluster (HBCD) do not present an unreasonable risk of injury to health or the environment under certain conditions of use and declining to consider certain uses and pathways through which Petitioner’s members are exposed and face risks of exposure to HBCD.

EPA published a notice of availability for the final risk evaluation and order for HBCD in the Federal Register on September 25, 2020 (at 86 Fed. Reg.

60,456). The final risk evaluation and order were accordingly “issue[d]” for purposes of judicial review on October 9, 2020. 40 C.F.R. § 23.5(a); *see also* 15 U.S.C. §§ 2605(i)(1), 2618(a). A copy of EPA’s notice of availability is attached as Exhibit 1 to this petition, and a copy of EPA’s final risk evaluation and order (downloaded from EPA’s website on September 25, 2020, via https://www.epa.gov/sites/production/files/2020-09/documents/1._risk_evaluation_for_cyclic_aliphatic_bromide_cluster_hbcd_casrn25637-99-4_casrn_3194-5_casrn_3194-57-8.pdf) is attached as Exhibit 2.

Petitioner Alaska Community Action on Toxics’ principal place of business is within this Circuit. This Court accordingly has jurisdiction to review EPA’s order pursuant to 15 U.S.C. § 2618(a).

Dated: October 16, 2020

Respectfully submitted,

s/Tosh Sagar

TOSH SAGAR

Earthjustice

1001 G St. NW, Suite 1000

Washington, DC 20001

T: (202) 667-4500

tsagar@earthjustice.org

LAKENDRA S. BARAJAS

SHARMEEN MORRISON

Earthjustice

48 Wall St., 15th Floor

New York, NY 10005

T: (212) 845-8025

T: (212) 845-8034

lbarajas@earthjustice.org

smorrison@earthjustice.org

Attorneys for Petitioner Alaska
Community Action on Toxics

**UNITED STATES COURT OF APPEALS
FOR THE NINTH CIRCUIT**

ALASKA COMMUNITY ACTION ON TOXICS,

Petitioner,

v.

UNITED STATES ENVIRONMENTAL
PROTECTION AGENCY, and ANDREW
WHEELER, Administrator, United States
Environmental Protection Agency,

Respondents.

No. _____

RULE 26.1 CORPORATE DISCLOSURE STATEMENT

Petitioner Alaska Community Action on Toxics is a nonprofit organization with no parent companies, subsidiaries, or affiliates that have issued shares to the public in the United States or abroad. No publicly held corporation owns 10% or more of stock in Alaska Community Action on Toxics.

Dated: October 16, 2020

Respectfully submitted,

s/Tosh Sagar

TOSH SAGAR

Earthjustice

1001 G St. NW, Suite 1000

Washington, DC 20001

T: (202) 667-4500

tsagar@earthjustice.org

LAKENDRA S. BARAJAS
SHARMEEN MORRISON
Earthjustice
48 Wall St., 15th Floor
New York, NY 10005
T: (212) 845-8025
T: (212) 845-8034
lbarajas@earthjustice.org
smorrison@earthjustice.org

Attorneys for Petitioner Alaska
Community Action on Toxics

Exhibit 1

ENVIRONMENTAL PROTECTION AGENCY

[FRL-10015-06-OA]

Notice of Meeting of the EPA Children's Health Protection Advisory Committee (CHPAC)

AGENCY: Environmental Protection Agency (EPA).

ACTION: Notice.

SUMMARY: Pursuant to the provisions of the Federal Advisory Committee Act, notice is hereby given that the next meeting of the Children's Health Protection Advisory Committee (CHPAC) will be held virtually October 22, 2020. The CHPAC advises the Environmental Protection Agency (EPA) on science, regulations and other issues relating to children's environmental health.

DATES: October 22, 2020 from 2 p.m. to 5 p.m.

ADDRESSES: The meeting will take place virtually. If you want to listen to the meeting or provide comments, please email louie.nica@epa.gov for further details.

FOR FURTHER INFORMATION CONTACT: Nica Louie, Office of Children's Health Protection, U.S. EPA, MC 1107T, 1200 Pennsylvania Avenue NW, Washington, DC 20460, (202) 564-7633 or louie.nica@epa.gov.

SUPPLEMENTARY INFORMATION: The meetings of the CHPAC are open to the public. An agenda will be posted to <https://www.epa.gov/children/childrens-health-protection-advisory-committee-chpac>.

Access and Accommodations: For information on access or services for individuals with disabilities, please contact Nica Louie at 202-564-7633 or louie.nica@epa.gov.

Dated: September 16, 2019.

Nica Mostaghim,

Environmental Health Scientist.

[FR Doc. 2020-21143 Filed 9-24-20; 8:45 am]

BILLING CODE 6560-50-P

ENVIRONMENTAL PROTECTION AGENCY

[EPA-HQ-OPPT-2019-0237; FRL-10014-87]

Cyclic Aliphatic Bromide Cluster (HBCD); Final Toxic Substances Control Act (TSCA) Risk Evaluation; Notice of Availability

AGENCY: Environmental Protection Agency (EPA).

ACTION: Notice.

SUMMARY: The Environmental Protection Agency (EPA) is announcing the availability of the final Toxic Substances Control Act (TSCA) risk evaluation of Cyclic Aliphatic Bromide Cluster (HBCD). The purpose of conducting risk evaluations under TSCA is to determine whether a chemical substance presents an unreasonable risk of injury to health or the environment under the conditions of use, including an unreasonable risk to a relevant potentially exposed or susceptible subpopulation, without consideration of costs or other nonrisk factors. EPA has determined that specific conditions of use of HBCD present an unreasonable risk of injury to health or the environment. For those conditions of use for which EPA has found an unreasonable risk, EPA must take regulatory action to address that unreasonable risk through risk management measures enumerated in TSCA. EPA has also determined that specific conditions of use do not present unreasonable risk of injury to health or the environment. For those conditions of use for which EPA has found no unreasonable risk to health or the environment, the Agency's determination is a final Agency action and is issued via order in the risk evaluation.

ADDRESSES: The docket for this action, identified by docket identification (ID) number EPA-HQ-OPPT-2019-0237, is available online at <http://www.regulations.gov> or in-person at the Office of Pollution Prevention and Toxics Docket (OPPT Docket), Environmental Protection Agency Docket Center (EPA/DC), West William Jefferson Clinton Bldg., Rm. 3334, 1301 Constitution Ave. NW, Washington, DC. The Public Reading Room is open from 8:30 a.m. to 4:30 p.m., Monday through Friday, excluding legal holidays. The telephone number for the Public Reading Room is (202) 566-1744, and the telephone number for the OPPT Docket is (202) 566-0280.

Due to the public health concerns related to COVID-19, the EPA Docket Center (EPA/DC) and Public Reading Room is closed to visitors with limited exceptions. The EPA/DC staff continue to provide remote customer service via email, phone, and webform. For the latest status information on EPA/DC services and docket access, visit <https://www.epa.gov/dockets>.

FOR FURTHER INFORMATION CONTACT: For technical information contact: Dr. Stan Barone, Office of Pollution Prevention and Toxics (7403M), Environmental Protection Agency, 1200 Pennsylvania Ave. NW, Washington, DC 20460-0001;

telephone number: (202) 564-1169; email address: barone.stan@epa.gov.

For general information contact: The TSCA-Hotline, ABVI-Goodwill, 422 South Clinton Ave., Rochester, NY 14620; telephone number: (202) 554-1404; email address: TSCA-Hotline@epa.gov.

SUPPLEMENTARY INFORMATION:

I. General Information

A. Does this action apply to me?

This action is directed to the public in general. This action may be of interest to persons who are or may be interested in risk evaluations of chemical substances under TSCA, 15 U.S.C. 2601 *et seq.* Since other entities may also be interested in this final risk evaluation, the EPA has not attempted to describe all the specific entities that may be affected by this action.

B. What is EPA's authority for taking this action?

TSCA section 6, 15 U.S.C. 2605, requires EPA to conduct risk evaluations to "determine whether a chemical substance presents an unreasonable risk of injury to health or the environment, without consideration of costs or other nonrisk factors, including an unreasonable risk to a potentially exposed or susceptible subpopulation identified as relevant to the risk evaluation by the Administrator, under the conditions of use." 15 U.S.C. 2605(b)(4)(A). TSCA sections 6(b)(4)(A) through (H) enumerate the deadlines and minimum requirements applicable to this process, including provisions that provide instruction on chemical substances that must undergo evaluation, the minimum components of a TSCA risk evaluation, and the timelines for public comment and completion of the risk evaluation. TSCA also requires that EPA operate in a manner that is consistent with the best available science, make decisions based on the weight of the scientific evidence and consider reasonably available information. 15 U.S.C. 2625(h), (i), and (k). TSCA section 6(i) directs that a determination of "no unreasonable risk" shall be issued by order and considered to be a final Agency action, while a determination of "unreasonable risk" is not considered to be a final Agency action. 15 U.S.C. 2605(i).

The statute identifies the minimum components for all chemical substance risk evaluations. For each risk evaluation, EPA must publish a document that outlines the scope of the risk evaluation to be conducted, which includes the hazards, exposures, conditions of use, and the potentially

exposed or susceptible subpopulations that EPA expects to consider. 15 U.S.C. 2605(b)(4)(D). The statute further provides that each risk evaluation must also: (1) Integrate and assess available information on hazards and exposures for the conditions of use of the chemical substance, including information that is relevant to specific risks of injury to health or the environment and information on relevant potentially exposed or susceptible subpopulations; (2) describe whether aggregate or sentinel exposures were considered and the basis for that consideration; (3) take into account, where relevant, the likely duration, intensity, frequency, and number of exposures under the conditions of use; and (4) describe the weight of the scientific evidence for the identified hazards and exposures. 15 U.S.C. 2605(b)(4)(F)(i)–(ii) and (iv)–(v). Each risk evaluation must not consider costs or other nonrisk factors. 15 U.S.C. 2605(b)(4)(F)(iii).

The statute requires that the risk evaluation process be completed within a specified timeframe and provide an opportunity for public comment on a draft risk evaluation prior to publishing a final risk evaluation. 15 U.S.C. 2605(b)(4).

Subsection 5.4.1 of the final risk evaluation for HBCD constitutes the order required under TSCA section 6(i)(1), and the “no unreasonable risk” determinations in that subsection are considered to be a final Agency action effective on the date of issuance of the order. In conducting risk evaluations, “EPA will determine whether the chemical substance presents an unreasonable risk of injury to health or the environment under each condition of use within the scope of the risk evaluation. . . .” 40 CFR 702.47. Under EPA’s implementing regulations, “[a] determination by EPA that the chemical substance, under one or more of the conditions of use within the scope of the risk evaluation, does not present an unreasonable risk of injury to health or the environment will be issued by order and considered to be a final Agency action, effective on the date of issuance of the order.” 40 CFR 702.49(d). For purposes of TSCA section 19(a)(1)(A), the date of issuance of the section 6(i)(1) order for HBCD shall be at 1:00 p.m. Eastern time (standard or daylight, as appropriate) on the date that is two weeks after the date when this notice is published in the **Federal Register**, which is in accordance with 40 CFR 23.5.

C. What action is EPA taking?

EPA is announcing the availability of the risk evaluation of the chemical

substance identified in Unit II. In this risk evaluation EPA has made unreasonable risk determinations on some of the conditions of use within the scope of the risk evaluation for this chemical. For those conditions of use for which EPA has found an unreasonable risk of injury to health or the environment, EPA must take regulatory action to address those risks through risk management measures enumerated in 15 U.S.C. 2605(a).

EPA also is announcing the availability of the information required to be provided publicly with each risk evaluation, which is available online at <http://www.regulations.gov> in the dockets identified. 40 CFR 702.51. Specifically, EPA has provided:

- The scope document and problem formulation (in Docket ID No. EPA–HQ–OPPT–2016–0735);
- Draft risk evaluation, and final risk evaluation (in Docket ID No. EPA–HQ–OPPT–2019–0237);
- All notices, determinations, findings, consent agreements, and orders (in Docket ID No. EPA–HQ–OPPT–2019–0237);
- Any information required to be provided to the Agency under 15 U.S.C. 2603 (in Docket ID No. EPA–HQ–OPPT–2016–0735 and Docket ID No. EPA–HQ–OPPT–2019–0237);
- A nontechnical summary of the risk evaluation (in Docket ID No. EPA–HQ–OPPT–2019–0237);
- A list of the studies, with the results of the studies, considered in carrying out each risk evaluation (Risk Evaluation for Cyclic Aliphatic Bromide Cluster (HBCD Cluster) in Docket ID No. EPA–HQ–OPPT–2019–0237);
- The final peer review report, including the response to peer review and public comments received during peer review (in Docket ID No. EPA–HQ–OPPT–2019–0237); and
- Response to public comments received on the draft scope and the draft risk evaluation (in Docket ID No. EPA–HQ–OPPT–2019–0237).

II. TSCA Risk Evaluation

A. What is EPA’s risk evaluation process for existing chemicals under TSCA?

The risk evaluation process is the second step in EPA’s existing chemical review process under TSCA, following prioritization and before risk management. As this chemical is one of the first ten chemical substances undergoing risk evaluation, the chemical substance was not required to go through prioritization (81 FR 91927, December 19, 2016) (FRL–9956–47). The purpose of conducting risk evaluations is to determine whether a chemical

substance presents an unreasonable risk of injury to health or the environment under the conditions of use, including an unreasonable risk to a relevant potentially exposed or susceptible subpopulation. As part of this process, EPA must evaluate both hazard and exposure, not consider costs or other nonrisk factors, use reasonably available information and approaches in a manner that is consistent with the requirements in TSCA for the use of the best available science, and ensure decisions are based on the weight of scientific evidence.

The specific risk evaluation process that EPA has established by rule to implement the statutory process is set out in 40 CFR part 702 and summarized on EPA’s website at <http://www.epa.gov/assessing-and-managing-chemicals-under-tsca/risk-evaluations-existing-chemicals-under-tsca>. As explained in the preamble to EPA’s final rule on procedures for risk evaluation (82 FR 33726, July 20, 2017) (FRL–9964–38), the specific regulatory process set out in 40 CFR part 702, subpart B is being followed for the first ten chemical substances undergoing risk evaluation to the maximum extent practicable.

Prior to the publication of this final risk evaluation, a draft risk evaluation was subject to peer review and public comment. EPA reviewed the report from the peer review committee and public comments and has amended the risk evaluation in response to these comments as appropriate. The public comments, peer review report, and EPA’s response to comments is in Docket ID No. EPA–HQ–OPPT–2019–0237. Prior to the publication of the draft risk evaluation, EPA made available the scope and problem formulation, and solicited public input on uses and exposure. EPA’s documents and the public comments are in Docket ID No. EPA–HQ–OPPT–2016–0735. Additionally, information about the scope, problem formulation, and draft risk evaluation phases of the TSCA risk evaluation for this chemical is at <https://www.epa.gov/assessing-and-managing-chemicals-under-tsca/risk-evaluation-cyclic-aliphatic-bromide-cluster-hbcd>.

B. What is Cyclic Aliphatic Bromide Cluster (HBCD Cluster)?

The cyclic aliphatic bromide cluster chemicals, including hexabromocyclododecane (HBCD), are flame retardants. Other uses include use as a component of solder and use in automobile replacement parts. EPA has not identified reasonably available information to suggest that HBCD is currently domestically manufactured in

any quantity. Companies have the ability to import the chemical in low volumes below the CDR reporting threshold.

Authority: 15 U.S.C. 2601 *et seq.*

Andrew Wheeler,
Administrator.

[FR Doc. 2020-21133 Filed 9-24-20; 8:45 am]

BILLING CODE 6560-50-P

ENVIRONMENTAL PROTECTION AGENCY

[ER-FRL-9053-1]

Environmental Impact Statements; Notice of Availability

Responsible Agency: Office of Federal Activities, General Information 202-564-5632 or <https://www.epa.gov/nepa>. Weekly receipt of Environmental Impact Statements (EIS) Filed September 14, 2020 10 a.m. EST Through September 21, 2020 10 a.m. EST

Pursuant to 40 CFR 1506.9.

Notice: Section 309(a) of the Clean Air Act requires that EPA make public its comments on EISs issued by other Federal agencies. EPA's comment letters on EISs are available at: <https://cdxnodengn.epa.gov/cdx-enepa-public/action/eis/search>.

EIS No. 20200188, Draft Supplement, USFS, WV, Mountain Valley Pipeline and Equitrans Expansion Project Draft Supplemental Environmental Impact Statement, Comment Period Ends: 11/09/2020, Contact: Ken Arney 888-603-0261.

EIS No. 20200189, Draft, USAF, GA, Moody Air Force Base Comprehensive Airspace Initiative, Comment Period Ends: 11/24/2020, Contact: Lorence Busker 229-257-2396.

EIS No. 20200190, Draft, USAF, TX, B-21 Main Operating Base (MOB 1) Beddown at Dyess AFB, Texas or Ellsworth AFB South Dakota, Comment Period Ends: 11/09/2020, Contact: Julianne Turko 210-925-3777.

EIS No. 20200191, Final, USFS, AK, Rulemaking for Alaska Roadless Areas, Review Period Ends: 10/26/2020, Contact: Ken Tu 303-275-5156.

EIS No. 20200192, Final Supplement, FDOT, FHWA, FL, Tampa Interstate Study, Contact: Luis D. Lopez Rivera 407-867-6420. Pursuant to U.S.C. 139(n)(2), FHWA has issued a single document that consists of a final supplemental environmental impact statement and record of decision. Therefore, the 30-day wait/review period under NEPA does not apply to this action.

EIS No. 20200193, Final, BR, CA, Truckee Canal Extraordinary Maintenance, Review Period Ends: 10/26/2020, Contact: Laurie Nicholas 775-884-8360.

EIS No. 20200194, Final, NNSA, SC, Plutonium Pit Production at the Savannah River Site in South Carolina, Review Period Ends: 10/26/2020, Contact: Ms. Jennifer Nelson 803-557-6372.

Amended Notice

EIS No. 20200168, Draft, FAA, CA, Bob Hope Hollywood Burbank Airport Replacement Passenger Terminal Project, Comment Period Ends: 10/27/2020, Contact: Edvige B. Mbakoup 424-405-7283. Revision to FR Notice Published 8/21/2020; Extending the Comment Period from 10/5/2020 to 10/27/2020.

EIS No. 20200182, Final, USFS, AZ, WITHDRAWN—Fossil Creek Wild and Scenic River Comprehensive River Management Plan, Contact: Mike Dechter 928-527-3416. Revision to FR Notice Published 09/18/2020; Officially Withdrawn per request of the submitting agency.

Dated: September 21, 2020.

Cindy S. Barger,

Director, NEPA Compliance Division, Office of Federal Activities.

[FR Doc. 2020-21174 Filed 9-24-20; 8:45 am]

BILLING CODE 6560-50-P

ENVIRONMENTAL PROTECTION AGENCY

[EPA-HQ-OPP-2020-0390; FRL-10014-21]

Ortho-Phthalaldehyde; Receipt of Application for Emergency Exemption, Solicitation of Public Comment

AGENCY: Environmental Protection Agency (EPA).

ACTION: Notice.

SUMMARY: EPA has received a specific exemption request from the National Aeronautics and Space Administration (NASA) to use the pesticide ortho-phthalaldehyde (OPA, CAS No. 643-79-8) to treat the coolant fluid of the internal active thermal control system of the International Space Station to control aerobic/microaerophilic bacteria in the aqueous coolant. The applicant proposes the use of a new chemical which has not been registered by EPA. Therefore, in accordance with the Code of Federal Regulations (CFR), EPA is soliciting public comment before making the decision whether to grant the exemption.

DATES: Comments must be received on or before October 13, 2020.

ADDRESSES: Submit your comments, identified by docket identification (ID) number EPA-HQ-OPP-2020-0390, by one of the following methods:

- **Federal eRulemaking Portal:** <http://www.regulations.gov>. Follow the online instructions for submitting comments. Do not submit electronically any information you consider to be Confidential Business Information (CBI) or other information whose disclosure is restricted by statute.

- **Mail:** OPP Docket, Environmental Protection Agency Docket Center (EPA/DC), (28221T), 1200 Pennsylvania Ave. NW, Washington, DC 20460-0001.

- **Hand Delivery:** To make special arrangements for hand delivery or delivery of boxed information, please follow the instructions at <http://www.epa.gov/dockets/contacts.html>.

Due to the public health concerns related to COVID-19, the EPA Docket Center (EPA/DC) and Reading Room is closed to visitors with limited exceptions. The staff continues to provide remote customer service via email, phone, and webform. For the latest status information on EPA/DC services and docket access, visit <https://www.epa.gov/dockets>.

FOR FURTHER INFORMATION CONTACT:

Marietta Echeverria, Registration Division (7505P), Office of Pesticide Programs, Environmental Protection Agency, 1200 Pennsylvania Ave. NW, Washington, DC 20460-0001; main telephone number: (703) 305-7090; email address: RDFRNotices@epa.gov.

SUPPLEMENTARY INFORMATION:

In accordance with the regulations at 40 CFR 166.24(a)(1), EPA is soliciting public comment before making the decision whether to grant the exemption.

I. General Information

A. Does this action apply to me?

You may be potentially affected by this action if you are a pesticide manufacturer (North American Industrial Classification System (NAICS) (Code 32532) or involved with the International Space Station. This listing is not intended to be exhaustive, but rather provides a guide to help readers determine whether this document applies to them. Other types of entities not listed could also be affected.

B. What should I consider as I prepare my comments for EPA?

1. **Submitting CBI.** Do not submit this information to EPA through www.regulations.gov or email. Clearly mark the part or all of the information that you claim to be CBI. For CBI

Exhibit 2



United States
Environmental Protection Agency

EPA Document #740-R1-8006
September 2020
Office of Chemical Safety and
Pollution Prevention

Risk Evaluation for Cyclic Aliphatic Bromide Cluster (HBCD)

CASRN: 25637-99-4

CASRN: 3194-55-6

CASRN: 3194-57-8

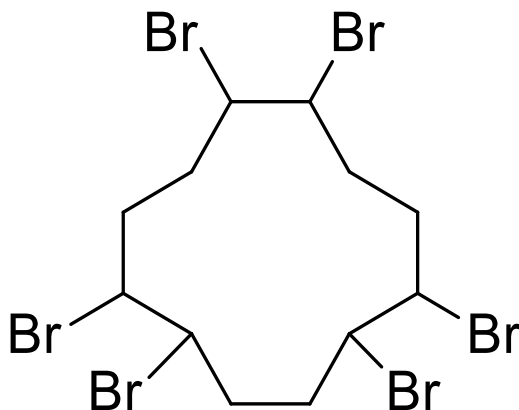

September 2020

TABLE OF CONTENTS

TABLE OF CONTENTS	2
ACKNOWLEDGEMENTS	22
ABBREVIATIONS	23
EXECUTIVE SUMMARY	28
1 INTRODUCTION	44
1.1 Physical and Chemical Properties	46
1.2 Uses and Production Volume	47
1.2.1 Data and Information Sources	47
1.2.2 Domestic Manufacture of HBCD	47
1.2.3 Importation of HBCD	50
1.2.4 Toxics Release Inventory Data on HBCD.....	51
1.2.5 Uses of HBCD	53
1.2.5.1 Automobile Replacement Parts	53
1.2.5.2 Expanded Polystyrene (EPS) and Extruded Polystyrene (XPS) Foam	54
1.2.5.3 Flux/Solder Paste.....	54
1.2.6 Recycling of EPS and XPS Foam.....	55
1.2.7 Recycling of Electronics Waste (E-Waste) Containing HIPS	56
1.2.8 Legacy Activities and Uses	56
1.2.9 Historical Activities Resulting in Continued Exposures	57
1.2.10 Summary.....	57
1.2.11 List of Conditions of Use.....	58
1.3 Regulatory and Assessment History	58
1.4 Scope of the Evaluation	60
1.4.1 Conditions of Use Included in the Risk Evaluation.....	60
1.4.2 Exposure Pathways and Risks Addressed by other EPA Administered Statutes	66
1.4.2.1 TSCA Authorities Supporting Tailored Risk Evaluations and Intra-agency Referrals..	66
1.4.2.2 EPA-administered Statutes and Regulatory Programs that Address Specific Exposure Pathways and/or Risks	69
1.4.3 Conceptual Models	70
1.5 Systematic Review.....	76
1.5.1 Data and Information Collection	76
2 EXPOSURES	83
2.1 Fate and Transport	83
2.1.1 Fate and Transport Approach and Methodology	83
2.1.2 Summary of Fate and Transport	84
2.1.2.1 Air.....	86
2.1.2.2 Water	86
2.1.2.3 Soil and Sediment.....	87
2.1.2.4 Wastewater Treatment Plants	87
2.1.2.5 Persistence	88
2.1.2.6 Bioaccumulation/Bioconcentration	88
2.1.2.7 PBT Characterization	89
2.1.3 Assumptions and Key Sources of Uncertainty for Fate and Transport	90

2.2	Releases to the Environment	97
2.2.1	Release Assessment Approach and Methodology	98
2.2.2	Repackaging of Import Containers	102
2.2.3	Compounding of Polystyrene Resin to Produce XPS Masterbatch.....	108
2.2.4	Processing to Produce XPS Foam using XPS Masterbatch.....	113
2.2.5	Processing of HBCD to Produce XPS Foam.....	118
2.2.6	Processing to Produce EPS Foam from Imported EPS Resin Beads.....	123
2.2.7	Processing to Produce SIPs and Automobile Replacement Parts from XPS/EPS Foam	129
2.2.8	Use: Installation of Automobile Replacement Parts.....	134
2.2.9	Use: Installation of XPS/EPS Foam Insulation in Residential, Public, and Commercial Buildings, and Other Structures	134
2.2.10	Demolition and Disposal of XPS/EPS Foam Insulation Products in Residential, Public and Commercial Buildings, and Other Structures.....	140
2.2.11	Processing: Recycling of EPS Foam and Reuse of XPS Foam	144
2.2.12	Formulation of Flux/Solder Pastes	148
2.2.13	Use of Flux/Solder Pastes.....	150
2.2.14	Recycling of Electronics Waste (E-Waste) Containing HIPS.....	156
2.2.15	Sensitivity Analysis - Process Volume.....	160
2.2.16	Assumptions and Key Sources of Uncertainties for Environmental Releases	166
2.3	Environmental Exposures.....	168
2.3.1	Approach and Methodology	168
2.3.2	Aquatic Environment - Surface Water and Sediment.....	173
2.3.2.1	Non-Scenario Specific Approach.....	173
2.3.2.1.1	Surface Water Concentrations	174
2.3.2.1.2	Sediment Concentrations	175
2.3.2.2	Scenario Specific Approach	176
2.3.2.2.1	E-FAST: Predicted Flowing Surface Water Concentrations (First Tier Modeling)	177
2.3.2.2.2	VVWM-PSC: Predicted Flowing Surface Water Concentrations (Second Tier Modeling) and Sediment Concentrations	179
2.3.2.2.3	IIOAC: Predicted Pond Water and Sediment Concentrations	183
2.3.3	Terrestrial Environment – Soil	185
2.3.3.1	Non-Scenario Specific Approach – Air Deposition and Biosolid Application.....	185
2.3.3.2	Scenario Specific Approach – Air Deposition	187
2.3.3.3	Combined Soil Concentration – Air Deposition, Background, Biosolid Application .	189
2.3.4	Assessment of Exposure in Targeted Wildlife	189
2.3.5	Summary of Results for Environmental Exposure Assessment	190
2.3.6	Sensitivity Analysis – Environmental Exposure	192
2.3.6.1	Modeled Sediment.....	192
2.3.6.2	Monitoring Data (General).....	192
2.3.6.3	Fish Tissue.....	192
2.3.6.4	Scenario Inputs (product amount, WWTR%)	192
2.3.7	Assumptions and Key Sources of Uncertainty in Environmental Exposure Assessment ...	196
2.4	Human Exposures.....	197
2.4.1	Occupational Exposures	200
2.4.1.1	Occupational Exposures Approach and Methodology	200
2.4.1.2	Repackaging of Import Containers.....	211

2.4.1.3	Compounding of Polystyrene Resin to Produce XPS Masterbatch.....	215
2.4.1.4	Processing of HBCD to Produce XPS Foam using XPS Masterbatch.....	221
2.4.1.5	Processing of HBCD to Produce XPS Foam Using HBCD Powder.....	224
2.4.1.6	Processing of HBCD to Produce EPS Foam from Imported EPS Resin Beads.....	226
2.4.1.7	Processing of HBCD to Produce SIPs and Automobile Replacement Parts from XPS/EPS Foam	230
2.4.1.8	Use: Installation of Automobile Replacement Parts	232
2.4.1.9	Use: Installation of XPS/EPS Foam Insulation in Residential, Public and Commercial Buildings, and Other Structures.....	232
2.4.1.10	Demolition and Disposal of XPS/EPS Foam Insulation Products in Residential, Public and Commercial Buildings, and Other Structures	234
2.4.1.11	Recycling of EPS Foam and Reuse of XPS Foam	237
2.4.1.12	Formulation of Flux/Solder Pastes	239
2.4.1.13	Use of Flux/Solder Paste	241
2.4.1.14	Recycling of Electronics Waste (E-Waste) Containing HIPS.....	242
2.4.1.15	Assumptions and Key Sources of Uncertainties for Occupational Exposures.....	247
2.4.1.15.1	Number of Workers	247
2.4.1.15.2	Estimation of Inhalation Exposure Concentration and Average Daily Dose	247
2.4.1.15.3	Modeling Dermal Exposures	248
2.4.1.15.4	Occupational Non-User (ONU) Potential Inhalation Exposure	248
2.4.1.15.5	Firefighter Potential Occupational Exposure.....	248
2.4.1.15.6	Summary of Occupational Exposures.....	249
2.4.2	General Population (Background) Exposures	255
2.4.2.1	General Population Exposure Approach and Methodology.....	255
2.4.2.2	Indirect Estimation Using Environmental Monitoring Data and Exposure Factors.....	256
2.4.2.2.1	Diet — Ingestion.....	259
2.4.2.2.2	Dust and Soil — Incidental Ingestion.....	262
2.4.2.2.3	Air — Inhalation.....	265
2.4.2.2.4	Dermal	267
2.4.2.2.5	Aggregate General Population Exposure and Dose.....	269
2.4.2.2.6	Occupational Microenvironments.....	271
2.4.2.3	Exposure Reconstruction Using Human Biomonitoring Data and Reverse Dosimetry.....	272
2.4.2.4	Comparison of General Population Approaches	274
2.4.2.5	General Population Subsistence Fisher Exposures.....	276
2.4.3	Highly Exposed General Population Exposures.....	277
2.4.3.1	Approach and Methodology	277
2.4.3.2	Near Facility Dietary (Fish) — Ingestion.....	278
2.4.3.3	Near Facility Suspended Particulates in Air — Inhalation	283
2.4.3.4	Aggregate Highly Exposed Population Exposure and Dose	288
2.4.4	Consumer Exposures	293
2.4.4.1	Approach and Methodology	293
2.4.4.2	XPS/EPS Insulation In Residences — Indoor Air and Settled Dust.....	293
2.4.4.3	Automobile Components that Contain HBCD — Indoor Air and Settled Dust.....	296
2.4.4.4	Recycled Consumer Articles that Contain HBCD — Mouthing.....	297

2.4.5	Qualitative Exposure Scenarios	299
2.4.5.1	Emissions to Ambient Air from EPS and XPS Insulation in Residences	299
2.4.5.2	HBCD Sent to Landfill Across the Lifecycle.....	300
2.4.5.3	Occupational Exposure Associated with the Condition of Use of Land Disposal of Formulated Products and Articles.....	301
2.4.6	Sensitivity Analysis - Human Exposure	304
2.4.6.1	Sensitivity Analysis – Infant Exposures.....	304
2.4.6.2	Sensitivity Analysis – Variation in Production Volume	306
2.4.7	Assumptions and Key Sources of Uncertainty in the General Population, Highly Exposed, and Consumer Exposure Assessment.....	307
2.4.8	Potentially Exposed or Susceptible Subpopulations.....	310
3	HAZARDS.....	313
3.1	Environmental Hazards	313
3.1.1	Approach and Methodology	313
3.1.2	Hazard Identification	313
3.1.2.1	Aquatic Toxicity	315
3.1.2.2	Terrestrial Organisms	319
3.1.3	HBCD Trophic Transfer in the Environment	321
3.1.4	Weight of the Scientific Evidence	328
3.1.5	Concentrations of Concern	329
3.1.6	Summary of Environmental Hazard	331
3.1.7	Assumptions and Key Sources of Uncertainty for the Environmental Hazard Assessment	332
3.2	Human Health Hazards.....	334
3.2.1	Approach and Methodology	334
3.2.2	Toxicokinetics.....	337
3.2.2.1	ADME	337
3.2.2.1.1	Absorption	337
3.2.2.1.2	Distribution	338
3.2.2.1.3	Metabolism	339
3.2.2.1.4	Elimination.....	341
3.2.2.2	Description of Toxicokinetic Models.....	343
3.2.3	Hazard Identification	344
3.2.3.1	Non-Cancer Hazards	344
3.2.3.1.1	Thyroid Effects	344
3.2.3.1.2	Liver Effects	345
3.2.3.1.3	Reproductive Effects.....	345
3.2.3.1.4	Developmental Effects.....	346
3.2.3.1.5	Neurological Effects	346
3.2.3.1.6	Immune System Effects	347
3.2.3.1.7	Overt Toxicity Following Acute/Short Term Exposure	347
3.2.3.1.8	Sensitization/Irritation	347
3.2.3.2	Genotoxicity and Cancer Hazards	348
3.2.4	Weight of the Scientific Evidence	350

3.2.4.1	Non-Cancer Hazards	350
3.2.4.1.1	Thyroid Effects	350
3.2.4.1.2	Liver Effects	353
3.2.4.1.3	Reproductive Effects.....	353
3.2.4.1.4	Developmental Effects.....	354
3.2.4.1.5	Neurological Effects	355
3.2.4.1.6	Immune System Effects	356
3.2.4.1.7	Overt Toxicity Following Acute/Short Term Exposures.....	357
3.2.4.1.8	Sensitization/Irritation	357
3.2.4.2	Genotoxicity/Carcinogenicity.....	358
3.2.4.3	Summary of Human Health Hazards Used to Evaluate Acute and Chronic Exposures	358
3.2.5	Dose-Response Assessment.....	358
3.2.5.1	Selection of Studies for Non-Cancer Dose-Response Assessment	358
3.2.5.2	Derivation of Points of Departure and Uncertainty Factors	360
3.2.5.2.1	PODs for Acute Exposure.....	361
3.2.5.2.2	PODs for Chronic Exposures.....	364
3.2.5.2.3	Human Equivalent Doses.....	368
3.2.5.2.4	Uncertainty Factors.....	369
3.2.5.3	Points of Departure for Human Health Hazard Endpoints.....	370
3.2.6	Assumptions and Key Sources of Uncertainties for the Human Health Hazard Assessment	377
3.2.6.1	Toxicokinetics	377
3.2.6.2	Human Health Endpoints	377
3.2.7	Potentially Exposed or Susceptible Subpopulations.....	379
4	RISK CHARACTERIZATION	381
4.1	Environmental Risk	381
4.1.1	Environmental Risk Estimation.....	384
4.1.1.1	Environmental Effect Levels of HBCD	384
4.1.1.2	Acute and Chronic Concentrations of Concern.....	384
4.1.2	Calculation of Risk Quotient (RQ) Values for HBCD	386
4.1.3	Risk Estimation Approach.....	386
4.1.3.1	Risk Estimation Based on HBCD Surface Water and Sediment Concentrations using Environmental Monitoring Data and Modeling Results.....	389
4.1.3.1.1	Risk Estimation Based on Surface Water and Sediment Monitoring Data	389
4.1.3.1.2	Risk Estimation Based on Surface Water and Sediment Modeling Data	391
4.1.3.1.3	Risk Estimation for the Recycling of Electronics Waste Containing HIPS	393
4.1.3.2	Risk Estimation based on HBCD Soil Concentrations using Environmental Monitoring and Modeling Data.....	393
4.1.3.2.1	Risk Estimation Based on Soil Monitoring Data.....	393
4.1.3.2.2	Risk Estimation Based on Soil Modeling Data	393

4.1.3.2.3	Risk Estimation for the Recycling of Electronics Waste Containing HIPS	394
4.1.3.3	Risk Estimation based on Exposure via Trophic Transfer	395
4.1.4	Environmental Risk Results	396
4.1.4.1	Risk Characterization for Aquatic and Terrestrial Ecosystems based on Environmental Monitoring Data.....	397
4.1.4.2	Risk Characterization for Aquatic and Terrestrial Ecosystems based on Modeled Surface Water and Sediment Concentrations	398
4.1.4.3	Risk Characterization for Aquatic and Terrestrial Ecosystems based on Exposure via Potential Trophic Transfer of HBCD.....	404
4.1.4.4	Targeted Sensitivity Analysis.....	405
4.1.4.4.1	Summary of Ranges of RQs: Production Volume.....	406
4.2	Human Health Risk.....	410
4.2.1	Risk Estimation Approach.....	410
4.2.1.1	Representative Points of Departure for Use in Risk Estimation	412
4.2.2	Risk Estimation for Workers	413
4.2.2.1	Occupational Risk Estimation for Non-Cancer Effects Following Acute Inhalation Exposures.....	416
4.2.2.2	Occupational Risk Estimation for Non-Cancer Effects Following Chronic Inhalation Exposures.....	418
4.2.2.3	Occupational Risk Estimation for Non-Cancer Effects Following Acute Dermal Exposures.....	422
4.2.2.4	Occupational Risk Estimation for Non-Cancer Effects Following Chronic Dermal Exposures.....	423
4.2.2.5	Occupational Risk Estimation for the Recycling of Electronics Waste Containing HIPS	424
4.2.3	Risk Estimation for General Population and Consumers	425
4.2.3.1	General Population Risk Estimation for Non-Cancer Effects – Background Exposure	425
4.2.3.1.1	Occupational Microenvironments.....	426
4.2.3.2	General Population Risk Estimation for Non-Cancer Effects – Subsistence Fishers ..	427
4.2.3.3	General Population Risk Estimation for Non-Cancer Effects – Highly Exposed Populations.....	428
4.2.3.3.1	General Population Risk Estimation for Non-Cancer Effects Following Acute Exposures – Highly Exposed Populations	429
4.2.3.3.2	General Population Risk Estimation for Non-Cancer Effects Following Chronic Exposures – Highly Exposed Populations	434
4.2.3.4	Targeted Sensitivity Analysis.....	438
4.3	Assumptions and Key Sources of Uncertainty for the Risk Characterization.....	439
4.3.1	Assumptions and Key Sources of Uncertainties for the Environmental Risk Characterization	439
4.3.1.1	Confidence in Risk Estimates.....	443
4.3.2	Assumptions and Key Sources of Uncertainties for the Human Health Risk Characterization	444
4.3.2.1	Physical-Chemical Properties and Toxicokinetics Considerations	444
4.3.2.2	Human Health Hazard Considerations	445
4.3.2.3	Occupational Exposure Considerations and Confidence Statements.....	446
4.3.2.4	PPE Considerations	447

4.3.2.5	General Population/Consumer Exposure Considerations and Confidence Statements	447
4.3.2.6	Considerations of Historical Production Volumes and Activities.....	448
4.4	Other Risk Related Considerations.....	449
4.4.1	Potentially Exposed or Susceptible Subpopulations.....	449
4.4.2	Aggregate and Sentinel Exposures	450
4.5	Risk Conclusions	451
4.5.1	Environmental Risk Conclusions	451
4.5.1.1	Summary of Risk Estimates for Aquatic Organisms.....	451
4.5.1.2	Summary of Risk Estimates for Terrestrial Organisms.....	453
4.5.2	Human Health Risk Conclusions.....	459
4.5.2.1	Summary of Risk Estimates for Workers.....	459
4.5.2.2	Summary of Risk Estimates for General Population and Consumers.....	464
5	UNREASONABLE RISK DETERMINATION.....	468
5.1	Overview.....	468
5.1.1	Human Health.....	468
5.1.1.1	Non-Cancer Risk Estimates.....	469
5.1.1.2	Cancer Risk Estimates.....	469
5.1.1.3	Determining Unreasonable Risk of Injury to Health.....	469
5.1.2	Environment	470
5.1.2.1	Determining Unreasonable Risk of Injury to the Environment.....	471
5.2	Detailed Unreasonable Risk Determinations by Condition of Use	472
5.2.1	Human Health.....	473
5.2.1.1	Manufacturing – Import – (Import).....	473
5.2.1.2	Processing – Incorporated into Formulation, Mixture or Reaction Product – Flame Retardants used in Custom Compounding of Resin (<i>e.g.</i> , compounding in XPS masterbatch) and in Solder Paste	475
5.2.1.3	Processing – Incorporation into an Article – Flame Retardants used in Plastics Product Manufacturing (manufacture of XPS and EPS foam; manufacture of structural insulation panels (SIPS) and automobile replacement parts from XPS and EPS foam)	477
5.2.1.4	Processing – Recycling – Recycling of XPS and EPS Foam, Resin, Panels containing HBCD	478
5.2.1.5	Processing – Recycling – Recycling of electronics waste containing HIPS that contain HBCD	479
5.2.1.6	Distribution in Commerce – Distribution – Distribution	480
5.2.1.7	Commercial/Consumer Use – Building/Construction Materials – Plastic Articles (hard Construction and Building Materials covering Large Surface Areas (<i>e.g.</i> , EPS/XPS foam insulation in residential, public and commercial buildings, and other structures) and Solder Paste.....	480
5.2.1.8	Commercial/Consumer Use – Other - Automobile Replacement Parts and Plastic and Other Articles.....	483
5.2.1.9	Commercial/Consumer Use – Other – Formulated Products and Articles.....	485
5.2.1.10	Disposal – Other Land Disposal (<i>e.g.</i> construction and demolition waste) – Demolition and Disposal of XPS/EPS Foam Insulation Products in Residential, Public and Commercial Buildings and Other Structures	486
5.2.1.11	Disposal –Disposal of Formulated Products and Articles	488
5.2.2	Environment	490
5.2.2.1	Manufacturing – Import – (Import).....	490

5.2.2.2	Processing – Incorporated into Formulation, Mixture or Reaction Product – Flame retardants used in Custom Compounding of Resin (<i>e.g.</i> , compounding in XPS masterbatch) and in Solder Paste	491
5.2.2.3	Processing – Incorporation into an Article – Flame Retardants used in Plastics Product Manufacturing (manufacture of XPS and EPS foam; manufacture of structural insulation panels (SIPS) and automobile replacement parts from XPS and EPS foam)	492
5.2.2.4	Processing – Recycling – Recycling of XPS and EPS Foam, Resin, Panels Containing HBCD	492
5.2.2.5	Processing – Recycling – Recycling of Electronics Waste Containing HIPS that Contain HBCD.....	493
5.2.2.6	Distribution in Commerce – Distribution – Distribution	493
5.2.2.7	Commercial/Consumer Use – Building/Construction Materials – Plastic Articles (hard Construction and Building Materials Covering Large Surface Areas (<i>e.g.</i> , EPS/XPS foam insulation in residential, public and commercial buildings, and other structures) and Solder Paste	494
5.2.2.8	Disposal – Other Land Disposal (<i>e.g.</i> construction and demolition waste) – Demolition and Disposal of XPS/EPS Foam Insulation Products in Residential, Public and Commercial Buildings and Other Structures	494
5.2.2.9	Disposal – Land Disposal of Formulated Products and Articles.....	495
5.3	Changes to the Unreasonable Risk Determination from Draft Risk Evaluation to Final Risk Evaluation	496
5.4	Unreasonable Risk Determination Conclusion.....	496
5.4.1	No Unreasonable Risk Determinations	496
5.4.2	Unreasonable Risk Determinations	497
REFERENCES.....		498
APPENDICES.....		537
Appendix A	REGULATORY HISTORY	537
A.1	Federal Laws and Regulations.....	537
A.2	State Laws and Regulations.....	538
A.3	International Laws and Regulations	540
Appendix B	LIST OF SUPPLEMENTAL DOCUMENTS.....	541
Appendix C	FATE AND TRANSPORT	543
C.1	Biodegradation.....	543
C.2	Bioconcentration/Bioaccumulation	545
C.3	Calculation of Lipid Normalized Bioaccumulation Factors for HBCD	548
Appendix D	RELEASES TO THE ENVIRONMENT	550
D.1	2017 TRI Releases Not Used in this Assessment.....	550
D.2	Evaluation of Environmental Release Data Sources	551
Appendix E	OCCUPATIONAL EXPOSURES.....	556
E.1	Inhalation Monitoring Data Summary.....	556
E.2	Summary of Other Assessment Approaches	563
E.3	Equations for Calculating Acute and Chronic (Non-Cancer) Inhalation Exposures.....	571
E.4	Sample Calculations for Calculating Acute and Chronic (Non-Cancer) Inhalation Exposure ..	575

E.5	Approaches for Estimating Number of Workers	576
E.6	Evaluation of Occupational Exposure Data Sources	579
E.7	Data Integration Strategy for Occupational Exposure and Release Data/ Information.....	588
E.8	Information on the Age of Employed Persons	593
Appendix F	ENVIRONMENTAL EXPOSURES	595
F.1	Modeled Exposure Scenarios Across Conditions of Use	595
F.1.1	Water Releases.....	595
F.1.2	Air Releases	604
F.2	E-FAST and VVWM-PSC Modeling.....	610
F.3	IIOAC Modeling.....	614
Appendix G	GENERAL POPULATION, HIGHLY EXPOSED AND CONSUMER EXPOSURES	617
G.1	Exposure Factors for General Population, Highly Exposed, and Consumer Exposure Calculations	617
G.2	Scenario G1: General Population	622
G.3	Scenario H1: Near Facility Dietary (Fish) — Ingestion.....	624
G.4	Scenario H2: Near Facility Suspended Particulates in Air — Inhalation.....	635
G.5	Scenarios C1 and C2: Consumer Exposure to XPS/EPS Insulation in Residences and Automobiles Calculations.....	646
G.5.1	General Mass Balance Equation Used in IECCU.....	646
G.5.2	Typical Residential House.....	647
G.5.3	Typical Passenger Vehicle.....	647
G.5.4	Estimation of Key Parameters	648
G.5.5	Model Parameters	650
G.5.6	Simulation Results	651
G.5.7	Discussion.....	654
Appendix H	ENVIRONMENTAL HAZARDS.....	658
H.1	Supplemental Environmental Hazard Information.....	658
H.2	Calculations Used to Evaluate the Potential Trophic Transfer of HBCD	658
H.3	KABAM Outputs for Aquatic HBCD Bioaccumulation and Bioconcentration.....	659
H.3.1	10 th Percentile Surface and Pore Water Concentrations	659
H.3.2	50 th Percentile Surface and Pore Water Concentrations	662
Appendix I	BMD MODELING RESULTS FOR SELECTED PODs.....	665
I.1	Noncancer Endpoints for BMD Modeling	665
I.1.1	Thyroid Effects	667
I.1.2	Liver Effects	670
I.1.3	Reproductive Effects	674
I.1.4	Developmental Effects.....	676
Appendix J	ENVIRONMENTAL RISK	686
J.1	Aquatic Environment.....	686
J.1.1	Risk Quotients based on a Production Volume of 100,000 lbs/yr and 0% Removal from Direct Releases	686
J.1.1.1	E-FAST Initial Screening for Surface Water Concentrations	686
J.1.1.2	PSC Predicted Surface Water and Sediment Concentrations.....	691

J.1.2	Targeted Sensitivity Analysis	701
J.1.2.1	Exposure Scenario 1: Repackaging of Import Containers	701
J.1.2.2	Exposure Scenario 3: Processing of HBCD to produce XPS Foam using XPS Masterbatch.....	705
J.1.2.3	Exposure Scenario 5: Processing of HBCD to Produce EPS Foam from Imported EPS Resin Beads.....	710
J.1.2.4	Trophic Transfer: Risk Quotients for Terrestrial Mammals based on KABAM.....	715
J.1.3	Terrestrial Environment.....	717
J.1.3.1	IIOAC Predicted Soil Concentrations via Air Deposition	717
Appendix K	Human Health Risk	719
K.1	Targeted Sensitivity Analysis	719
Appendix L	Dermal Absorption Estimate Method Comparison.....	721
L.1	Fraction Absorbed Method As Used in Risk Evaluation.....	721
L.2	Permeability Method	721
L.3	Method Comparison	722
L.3.1	Occupational Exposure Using Flux	722
L.3.2	General Population Considerations	723

LIST OF TABLES

Table 1-1. Physical and Chemical Properties of HBCD.....	47
Table 1-2. Production Volume (Manufacture and Import) of HBCD in CDR Reporting Period (2012 to 2015) ^a	48
Table 1-3. Conditions under Which a Company Must Report to CDR (shaded area applies to HBCD reporting specifically and “x” indicates broad conditions requiring reporting)	49
Table 1-4. U.S. Volume of Imports of HBCD, 2016 through July 2020.....	50
Table 1-5. Summary of HBCD TRI Production-Related Waste Managed from 2017-2018 (lbs)	52
Table 1-6. Summary of HBCD TRI Releases to the Environment from 2017-2018 (lbs)	53
Table 1-7. Assessment History of HBCD.....	59
Table 1-8. Categories and Subcategories of Conditions of Use and Corresponding Exposure Scenario Included in the Scope of the Risk Evaluation for HBCD ^a	62
Table 2-1. Summary of Environmental Fate and Transport Properties for HBCD	84
Table 2-2. HBCD Biodegradation Half-Lives Selected for Use in Risk Evaluation.....	91
Table 2-3. HBCD Biodegradation Half-lives (days) Reported and Representative Half-lives Calculated Using OPP/NAFTA Guidance.....	93
Table 2-4. Impact of the Use of the Range of Biodegradation Half-lives (days) Reported and Representative Half-lives Calculated Using OPP/NAFTA Guidance on PSC-VVWM Concentration Estimates ^a	93
Table 2-5. HBCD Bioaccumulation and Bioconcentration Factors Reviewed for Use in the Risk Evaluation	96
Table 2-6. Summary of HBCD Release Sources During Repackaging of Import Containers	104
Table 2-7. Repackaging of Import Containers – HBCD Release Data Source Evaluation	105
Table 2-8. Input Variables to Equation 2-1 for Repackaging of HBCD Import Containers	105
Table 2-9. Summary of HBCD Releases from Repackaging of Import Containers.....	107
Table 2-10. HBCD Release Data Reported in the EURAR for XPS Masterbatch Production	109
Table 2-11. Compounding of Polystyrene to Produce XPS Masterbatch Release Data Source Evaluation	110
Table 2-12. Input Variables to Equation 2-1 for XPS Masterbatch Production	110
Table 2-13. Summary of HBCD Releases from XPS Masterbatch Production.....	112
Table 2-14. HBCD Release Data Reported in the EURAR for Manufacturing of XPS Foam from XPS Masterbatch.....	114
Table 2-15. XPS Foam Manufacturing Using XPS Masterbatch Release Data Source Evaluation.....	115
Table 2-16. Input Variables to Equation 2-1 for XPS Foam Manufacturing Using XPS Masterbatch..	115
Table 2-17. Summary of HBCD Releases from XPS Foam Manufacturing Using XPS Masterbatch ..	117
Table 2-18. HBCD Release Data Reported in the EURAR for Manufacturing of XPS Foam using HBCD Powder	119
Table 2-19. Manufacturing of XPS Foam Using HBCD Powder Release Data Source Evaluation	120
Table 2-20. Input Variables to Equation 2-1 for XPS Foam Manufacturing Using HBCD Powder.....	121
Table 2-21. Summary of HBCD Releases from XPS Foam Manufacturing Using HBCD	122
Table 2-22. Summary of HBCD Releases from XPS Foam Manufacturing Using HBCD from 2017 TRI Data.....	122
Table 2-23. Summary of HBCD Releases During Manufacturing of EPS Foam from the 2009 OECD ESD on Plastics Additives and Standard EPA/OPPT Models.....	125
Table 2-24. Manufacturing of EPS Foam from Imported EPS Resin Beads Release Data Source Evaluation	126
Table 2-25. Input Variables to Equation 2-1 for EPS Foam Manufacturing from EPS Resin Beads	126
Table 2-26. Summary of HBCD Releases from EPS Foam Manufacturing from EPS Resin Beads.....	128

Table 2-27. Summary of HBCD Release Sources During the Manufacturing of SIPs and Automobile Replacement Parts from XPS/EPS Foam	130
Table 2-28. Manufacturing of SIPs and Automobile Replacement Parts from XPS/EPS Foam Release Data Source Evaluation.....	131
Table 2-29. Input Variables to Equation 2-1 for the Manufacturing of SIPs and Automobile Replacement Parts from XPS/EPS Foam	131
Table 2-30. Summary of HBCD Releases from the Manufacturing of SIPs and Automobile Replacement Parts from XPS/EPS Foam	133
Table 2-31. Particle Generation Factors Reported in the EURAR for Sawing or Cutting of XPS/EPS Foam Prior to Installation	136
Table 2-32. Summary of HBCD Release Sources During Installation of XPS/EPS Foam Insulation in Residential, Public, and Commercial Buildings, and Other Structures	136
Table 2-33. Installation of XPS/EPS Foam Insulation in Residential, Public and Commercial Buildings, and Other Structures Release Data Source Evaluation	137
Table 2-34. Input Variables to Equation 2-1 for the Installation of XPS/EPS Foam Insulation in Residential, Public and Commercial Buildings, and Other Structures	137
Table 2-35. Summary of HBCD Releases from Installation of XPS/EPS Foam Insulation in Residential, Public and Commercial Buildings, and Other Structures	139
Table 2-36. Particle Generation Factors for the Demolition of XPS and EPS	141
Table 2-37. Demolition of XPS/EPS Foam Insulation in Residential, Public and Commercial Buildings, and Other Structures Release Data Source Evaluation	142
Table 2-38. Summary of HBCD Releases from Demolition of XPS/EPS Foam Insulation in Residential, Public and Commercial Buildings, and Other Structures	142
Table 2-39. Summary of HBCD Releases from Demolition of XPS/EPS Foam Insulation in Residential, Public and Commercial Buildings, and Other Structures	143
Table 2-40. Recycling of EPS Foam Release Data Source Evaluation	145
Table 2-41. Input Variables to Equation 2-1 for the Recycling of EPS Foam	145
Table 2-42. Summary of HBCD Releases from the Recycling of EPS Foam.....	147
Table 2-43. Formulation of Flux/Solder Pastes Release Data Source Evaluation.....	149
Table 2-44. Summary of HBCD Releases from Flux/Solder Paste Formulation Sites from 2017 TRI Data	150
Table 2-45. Summary of HBCD Release Sources During Use of Flux and Solder Pastes.....	153
Table 2-46. Use of Flux and Solder Pastes Release Data Source Evaluation.....	154
Table 2-47. Input Variables to Equation 2-1 for Use of Flux and Solder Pastes.....	154
Table 2-48. Summary of HBCD Releases from Use of Flux and Solder Pastes	155
Table 2-49. Values, References for, and Overall Confidence Ratings of Input Variables of Equations HBCD Release Rate from E-Waste Recycling Sites	159
Table 2-50. Summary of HBCD Releases from Sensitivity Analysis of Repackaging of Import Containers	162
Table 2-51. Summary of HBCD Releases from Sensitivity Analysis of XPS Foam Manufacturing Using XPS Masterbatch	163
Table 2-52. Summary of HBCD Releases from Sensitivity Analysis of EPS Foam Manufacturing from EPS Resin Beads.....	164
Table 2-53. Overview of Approaches Used in HBCD Environmental Exposure Assessment.....	170
Table 2-54. Summary of Subscenarios Used Across Conditions of Use for Water Releases of HBCD	171
Table 2-55. Summary of Scenarios Used Across Conditions of Use for Air Releases of HBCD.....	172
Table 2-56. Summary of Central Tendency and High-End Estimated Surface Water Concentrations from Monitoring Data.....	175

Table 2-57. Summary of Central Tendency and High-End Estimated Sediment Concentrations from Monitoring Data.....	176
Table 2-58. Receiving Stream Flow Values	178
Table 2-59. Estimated HBCD Surface Water ($\mu\text{g/L}$) Concentrations Using E-FAST	178
Table 2-60. Inputs for Modeling HBCD Sediment Concentration using VVWM-PSC.....	180
Table 2-61. Estimated HBCD Surface Water Concentrations ($\mu\text{g/L}$) and Sediment Concentrations ($\mu\text{g/kg}$) Using VVWM-PSC with 50 th Percentile 7Q10 Flows	181
Table 2-62. Estimated HBCD Surface Water Concentrations ($\mu\text{g/L}$) and Sediment Concentrations ($\mu\text{g/kg}$) Using VVWM-PSC with 10 th Percentile 7Q10 Flows	182
Table 2-63. Summary of Annualized Deposition and Estimated Pond Surface Water and Sediment Concentration from Air Deposition	185
Table 2-64. Summary of Central Tendency and High-End Estimated Soil Concentrations from Monitoring Data.....	186
Table 2-65. Summary of Annualized Deposition and Estimated Soil Concentration from Air Deposition	189
Table 2-66. Comparison of Published Literature and Modeling Results for Concentrations of HBCD in Surface Water, Sediment, and Soil	190
Table 2-67. Sensitivity Analysis of Central Tendency Estimate Assumptions in Monitoring Data	192
Table 2-68. Summary of HBCD Surface Water Concentrations from Sensitivity Analysis: Varying Production Volume and Waste Water Treatment Removal– Environmental Exposures	195
Table 2-69. Exposure Scenarios Descriptions for Receptor Groups	198
Table 2-70. Summary of Inhalation Exposure Assessment Approaches.....	203
Table 2-71. A Summary for Each of the 12 Occupational Exposure Scenarios (OESs).....	208
Table 2-72. Assigned Protection Factors for Respirators in OSHA Standard 29 CFR Section 1910.134	210
Table 2-73. Inhalation Monitoring Data for Manufacturing of HBCD	213
Table 2-74. Summary of Inhalation Monitoring Data for Handling of HBCD	217
Table 2-75. Summary of Inhalation Monitoring Data for the Manufacture of XPS Foam Using XPS Masterbatch Containing HBCD.....	223
Table 2-76. Summary of Inhalation Monitoring Data for Handling of XPS and EPS Foam Containing HBCD	229
Table 2-77. U.S. Number of Establishments and Employees for Installation of XPS/EPS Foam Insulation in Residential, Public and Commercial Buildings, and Other Structures	233
Table 2-78. U.S. Number of Establishments and Employees for Formulation of Solder Flux	240
Table 2-79. Inhalation Monitoring Data for HBCD at Electronics Recycling Sites	244
Table 2-80. Acute and Chronic Inhalation Exposure Estimates, Worker Occupational Scenarios ^a	251
Table 2-81. Acute and Chronic Dermal Exposure Estimates, Worker Occupational Scenarios	252
Table 2-82. Summary of Monitoring Studies Identified and Used in the General Population Exposure Assessment.....	258
Table 2-83. Summary of Concentrations and Ingestion Rates Used in General Population Diet Exposure Estimate.....	261
Table 2-84. Summary of Dust and Soil Inputs Used in Estimating Dust and Soil Ingestion Dose for HBCD	265
Table 2-85 Inputs for Estimation of HBCD Inhalation Dose	266
Table 2-86. Age Specific ADD for Dermal Exposure from Dust, Soil, and Materials	269
Table 2-87. General Population Central Tendency HBCD Exposure by Pathway and Age Group - (mg/kg/day).....	269

Table 2-88. General Population Central Tendency Source Contribution by Pathway and Age Group (% Contribution to Total HBCD Exposure)	270
Table 2-89. General Population High-End HBCD Exposure by Pathway and Age Group (mg/kg/day)	270
Table 2-90. General Population High-End Source Contribution by Pathway and Age Group (% Contribution to Total HBCD Exposure)	270
Table 2-91. Occupational Microenvironments Doses as a Percentage of Aggregate General Population Exposure	272
Table 2-92. Human HBCD Biomonitoring Data Sets by Population, Type and Number	272
Table 2-93. Measured HBCD Concentrations From Various Species and Locations in (Chen et al. 2011)	276
Table 2-94. Aggregate Central Tendency Exposure Comparison for Subsistence Fishers	277
Table 2-95. Summary of HBCD Fish Concentration Data for Estimating Fish Ingestion Dose	279
Table 2-96. Highly Exposed Group: Range of High-End HBCD Fish Ingestion Dose by Scenario and Age Group (mg/kg/day)	281
Table 2-97. Highly Exposed Group: Range of Central HBCD Fish Ingestion by Scenario and Age Group (mg/kg/day)	282
Table 2-98. Overall Summary of HBCD Averaged Indoor and Outdoor Air Concentrations for 12 Emission Scenarios	284
Table 2-99. Highly Exposed Group: Range of HBCD Inhalation Dose by Scenario and Age Group, Acute Dose Rate (mg/kg/day)	286
Table 2-100. Range of HBCD Inhalation Dose by Scenario and Age Group, Average Daily Dose (mg/kg/day)	287
Table 2-101. Range of HBCD Aggregate Exposure Acute Dose Rate (mg/kg/day) - Background and Modeled Fish Dose by Scenario and Age	289
Table 2-102. Range of HBCD Aggregate Exposure Average Daily Dose (mg/kg/day): Background and Modeled Fish Dose by Scenario and Age	289
Table 2-103. Range of HBCD Aggregate Exposure Acute Dose Rate (mg/kg/day): Background and Modeled Inhalation Dose by Scenario and Age	290
Table 2-104. Range of HBCD Aggregate Exposure Average Daily Dose (mg/kg/day): Background and Modeled Inhalation Dose by Scenario and Age	291
Table 2-105. Age Specific ADR Associated with Residential Insulation Scenario C1	295
Table 2-106. Age Specific ADD Associated with Residential Insulation Scenario C1	295
Table 2-107. Age Specific ADR Associated with HBCD in Automobile Component Scenario C2	297
Table 2-108. Age Specific ADD Associated with HBCD in Automobile Component Scenario C2	297
Table 2-109. Estimated Exposure from Mouthing of Articles Containing HBCD	298
Table 2-110. Sensitivity Analysis of Upper End Monitoring Distribution Assumptions in Monitoring Data	306
Table 2-111. Sensitivity Analysis of Central Tendency Estimate Assumptions in Monitoring Data	306
Table 2-112. Summary of Surface Water Concentrations from Sensitivity Analysis: Varying HBCD Production Volume and Waste Water Treatment Removal –Human Exposures (Fish Ingestion)	307
Table 2-113. Qualitative Assessment of the Uncertainty and Variability Associated with General Population Assessment	308
Table 2-114. Qualitative Assessment of the Uncertainty and Variability Associated with Highly Exposed Population Assessment	309
Table 3-1. Environmental Hazard Characterization of HBCD to Aquatic and Terrestrial Organisms ..	314

Table 3-2. Potential Trophic Transfer of HBCD in Aquatic and Terrestrial Ecosystems Using the U.S. EPA Final Water Quality Guidance for Great Lakes System and U.S. EPA Wildlife Exposure Factors Handbook	325
Table 3-3. Potential Trophic Transfer of HBCD in Aquatic and Terrestrial Ecosystems using the ECHA Guidance on Information Requirements and Chemical Safety Assessment (Environmental Exposure Assessment)	327
Table 3-4. Concentrations of Concern (COCs) for Aquatic Toxicity.....	330
Table 3-5. Terrestrial Effect Concentrations (Hazard) used to Evaluate Toxicity to Terrestrial Organisms	330
Table 3-6. Study Design Features of Developmental Toxicity Studies.....	362
Table 3-7. Study Design Features of Studies that Examined T4 Levels	365
Table 3-8. Study Design Features of Studies that Examined Liver Weight	367
Table 3-9. Summary of BMD Modeling Results and Derivation of HEDs for HBCD	370
Table 3-10. PODs and Benchmark MOEs for Effects Following Acute Exposure to HBCD.....	373
Table 3-11. PODs and Benchmark MOEs for Effects Following Chronic Exposure to HBCD	374
Table 3-12. PODs Selected for Risk Estimation for Each Target Organ/System.....	376
Table 4-1. Concentrations of Concern (COCs) Derived to Evaluate Toxicity to Aquatic Organisms for HBCD	385
Table 4-2. Hazard Effect Concentrations used to Evaluate Toxicity to Terrestrial Organisms	385
Table 4-3. Calculated Risk Quotients based on HBCD Surface Water ($\mu\text{g/L}$) Concentrations as Reported in Environmental Monitoring Studies.....	389
Table 4-4. Calculated Risk Quotients based on HBCD Sediment Concentrations ($\mu\text{g/kg}$) as Reported in Environmental Monitoring Studies.....	390
Table 4-5. Range of Risk Quotients for Modeled Surface Water and Sediment HBCD Concentrations for Each Condition of Use Using a Production Volume of 100,000 lbs/yr (0% removal for direct release).....	391
Table 4-6. Calculated Risk Quotients based on HBCD Soil Concentrations ($\mu\text{g/kg}$) as Reported in Environmental Monitoring Studies.....	393
Table 4-7. Calculated Risk Quotients based on HBCD Soil Concentrations ($\mu\text{g/kg}$) as Reported in Environmental Monitoring Studies and Calculated using Modeling Data	394
Table 4-8. Calculated Risk Quotients based on Potential Trophic Transfer of HBCD in Aquatic and Terrestrial Ecosystems Using the U.S. EPA Final Water Quality Guidance for Great Lakes System and U.S. EPA Wildlife Exposure Factors Handbook.....	395
Table 4-9. Calculated Risk Quotients based on Potential Trophic Transfer of HBCD in Aquatic and Terrestrial Ecosystems using the ECHA Guidance on Information Requirements and Chemical Safety Assessment (Environmental Exposure Assessment).....	396
Table 4-10. Range of Risk Quotients for Modeled Surface Water and Sediment HBCD Concentrations for Three Conditions of Use Scenarios Using a Production Volume of 100,000, 50,000, and 25,000 lbs/yr.....	407
Table 4-11. Use Scenarios, Populations of Interest and Toxicological Endpoints Used for Acute and Chronic Exposures	410
Table 4-12. Most Sensitive Endpoints From Each Health Domain Used for Risk Estimation	413
Table 4-13. Inhalation Exposure Data Summary and Respirator Use Determination	414
Table 4-14. Risk Estimation for Non-Cancer Effects Following Acute Inhalation Exposures	417
Table 4-15. Risk Estimation for Non-Cancer Effects Following Chronic Inhalation Exposures.....	419
Table 4-16. Risk Estimation for Non-Cancer Effects Following Acute Dermal Exposures	422
Table 4-17. Risk Estimate for Workers – Non-Cancer Effects Following Chronic Dermal Exposures	423
Table 4-18. Risk Estimates for Recycling of Electronics Waste Containing HIPS.....	424

Table 4-19. General Population Risk Estimation for Non-Cancer Effects – Background Exposure	426
Table 4-20. General Population Risk Estimation for Non-Cancer Effects – Subsistence Fishers	427
Table 4-21. Risk Estimation for Non-Cancer Effects Following Acute Exposure to Highly Exposed Population - Fish Ingestion	430
Table 4-22. Risk Estimation for Non-Cancer Effects Following Acute Exposure to Highly Exposed Population - Inhalation.....	432
Table 4-23. Risk Estimation for Non-Cancer Effects Following Acute Exposure to Highly Exposed Populations - Consumer Articles	433
Table 4-24. Risk Estimation for Non-Cancer Effects Following Chronic Exposure to Highly Exposed Population - Fish Ingestion	436
Table 4-25. Risk Estimation for Non-Cancer Effects Following Chronic Exposure to Highly Exposed Populations - Consumer Articles	438
Table 4-26. Summary of Risk for Aquatic Organisms	454
Table 4-27. Occupational Risk Summary Table.....	461
Table 4-28. Highly Exposed General Population/Consumer Risk Summary Table.....	465
Table 4-29. Risk Summary for Additional PESS Groups.....	467

LIST OF FIGURES

Figure 1-1. HBCD Life Cycle Diagram.....	65
Figure 1-2. HBCD Conceptual Model for Industrial and Commercial Activities and Uses: Worker and Occupational Non-User Exposures and Hazards.....	72
Figure 1-3. HBCD Conceptual Model for Consumer Activities and Uses: Consumer Exposures and Hazards	73
Figure 1-4. HBCD Conceptual Model for Environmental Releases and Wastes: General Population Exposures and Hazards.....	74
Figure 1-5. HBCD Conceptual Model for Environmental Releases and Wastes: Ecological Exposures and Hazards.....	75
Figure 1-6 HBCD Literature Flow Diagram for Environmental Fate and Transport Data Sources.....	78
Figure 1-7. HBCD Literature Flow Diagram for Environmental Releases and Occupational Exposure Data Sources	79
Figure 1-8. Literature Flow Diagram for General Population, Consumer and Environmental Exposure Data Sources for HBCD.....	80
Figure 1-9. Literature Flow Diagram for Environmental Hazard Data Sources for HBCD.....	81
Figure 1-10. Literature Flow Diagram for Human Health Hazard Key/Supporting Data Sources for HBCD	82
Figure 2-1. Abiotic Reduction of HBCD to 5,6,9,10-tetrabromocyclododec-1-ene (TBCD),	87
Figure 2-2. Overview of receptor groups considered within the Risk Evaluation.....	198
Figure 2-3 Overview of General Population Exposure Assessment.....	255
Figure 2-4 Two Exposure Assessment Approaches used to Estimate General Population Exposure to HBCD	256
Figure 2-5. Source Contribution by Pathway for Aggregate General Population Exposures	271
Figure 2-6. Comparison of HBCD Exposure via Environmental Monitoring/Exposure Factor and Human Biomonitoring/Reverse Dosimetry Approaches	275
Figure 2-7. Overview of exposure assessment method for highly exposed scenarios.....	278
Figure 2-8. Comparison of Potential HBCD Fish Ingestion Dose based on Modeled Surface Water Concentrations, Fish Tissue Monitoring Data, and Surface Water Monitoring Data.....	283
Figure 2-9. Overview of exposure assessment method for consumer exposure scenarios.....	293

Figure 2-10. Comparison of HBCD Dose for Infants in the General Population from Different Sensitivity Analyses.....	305
Figure 3-1. EPA Approach to Hazard Identification, Data Integration, and Dose-Response Analysis for HBCD	335
Figure 3-2 Proposed Pathways for Metabolism of HBCD in Rats	341

LIST OF APPENDIX TABLES

Table_Apx A-1. Federal Laws and Regulations.....	537
Table_Apx A-2. State Laws and Regulations.....	538
Table_Apx A-3. International Laws and Regulations	540
Table_Apx D-1. 2017 TRI Data Not Used in this Assessment	550
Table_Apx D-2. Summary of Release Data and Systematic Review Results	552
Table_Apx E-1. Inhalation Monitoring Data for Handling of HBCD.....	557
Table_Apx E-2. Inhalation Monitoring Data For Handling of XPS and EPS Foam Containing HBCD.....	561
Table_Apx E-3. Summary of HBCD Occupational Inhalation Exposure Assessment Results and the Associated Assessment Basis and Assessment Approach that are Reported in EU (2008)	564
Table_Apx E-4. Summary of HBCD Occupational Exposure Assessment Results and the Associated Assessment Basis and Approach that are Reported in NICNAS (2012)	566
Table_Apx E-5. Summary of Approaches from Other Risk Assessment Reports (RARs).....	568
Table_Apx E-6 Parameter Values for Calculating Inhalation Exposure Estimates	571
Table_Apx E-7. Overview of Average Worker Tenure from U.S. Census SIPP (Age Group 50+)	574
Table_Apx E-8. Median Years of Tenure with Current Employer by Age Group.....	574
Table_Apx E-9. SOCs with Worker and ONU Designations for All Exposure scenarios	576
Table_Apx E-10. Estimated Number of Potentially Exposed Workers and ONUs under NAICS 325991	577
Table_Apx E-11. Summary of Inhalation Monitoring Data and Systematic Review Results.....	580
Table_Apx E-12. Hierarchy guiding integration of occupational exposure data/information	591
Table_Apx E-13. Hierarchy guiding integration of environmental release data/information	592
Table_Apx E-14. Percentage of Employed Persons by Age, Sex, and Industry Sector	593
Table_Apx E-15. Percentage of Employed Persons Age 16-19 Years by Detailed Industry Sector.....	593
Table_Apx F-1. Scenarios Used Across Conditions of Use for Water Releases of HBCD	595
Table_Apx F-2. Scenarios Used Across Conditions of Use for Air Releases of HBCD.....	604
Table_Apx F-3. Estimated HBCD Surface Water ($\mu\text{g/L}$) Concentrations Using E-FAST	611
Table_Apx F-4. Total Annual Particle Deposition from Facility Air Releases.....	614
Table_Apx F-5. Estimated Soil Concentrations from Facility Air Releases	615
Table_Apx G-1. Body Weight by Age Group.....	617
Table_Apx G-2. Central Tendency (Mean) Dietary Ingestion Rates by Age Group- Fruit, Vegetables, Grains, Meats, Dairy, Fats, Consumers Only.	617
Table_Apx G-3. High-end (95 th Percentile) Dietary Ingestion Rates (Consumers Only) by Age Group- Fruit, Vegetables, Grains, Meats, Dairy, Fats.....	618
Table_Apx G-4. Fish Ingestion Rates by Age Group.....	618
Table_Apx G-5. Breastmilk Ingestion Rates	618
Table_Apx G-6. Inhalation Rate by Age Group.....	619
Table_Apx G-7. Dust and Soil Ingestion Rate by Age Group	619
Table_Apx G-8. Generic Activity Patterns for Time Spent While Awake	619
Table_Apx G-9. Generic Activity Patterns for Time Spent in a Day (24 hours)	620
Table_Apx G-10. Surface Area to Body Weight Ratios (cm^2/kg) By Age Group ^a	620

Table_Apx G-11. Dermal Adherence Factors for Dust By Age Group	621
Table_Apx G-12. Dermal Adherence Factors for Soil By Age Group.....	621
Table_Apx G-13. Surface Area of Object Mouthed (cm ²).....	622
Table_Apx G-14. Hourly Mouthing Duration (min).....	622
Table_Apx G-15. Estimated Average Daily Dose (ADD) by Age Group for Diet.....	622
Table_Apx G-16. Percent of Dietary ADD by Food Group.....	623
Table_Apx G-17. Estimated Average Dose Rate (ADR) by Age Group for Diet.....	623
Table_Apx G-18. Percent of Dietary ADR by Food Group.....	624
Table_Apx G-19. Surface Water Concentrations from VVWM-PSC Modeling and Calculated Fish Tissue Concentrations.....	624
Table_Apx G-20. Highly Exposed Acute Dose Rate and Average Daily Doses (mg/kg/day) for Modeled Fish Ingestion Only.....	627
Table_Apx G-21. Highly Exposed Aggregate Acute Dose Rate and Average Daily Doses (mg/kg/day) for Modeled Fish Ingestion and Background.....	631
Table_Apx G-22. Highly Exposed Acute Dose Rate (mg/kg/day) for Modeled Air Only	636
Table_Apx G-23. Highly Exposed Average Daily Dose (mg/kg/day) for Modeled Air Only.....	638
Table_Apx G-24. Highly Exposed Aggregate Acute Dose Rate (mg/kg/day) for Modeled Air and Non- Air and Background.....	641
Table_Apx G-25. Highly Exposed Aggregate Average Daily Dose (mg/kg/day) for Modeled Air and Non-Air and Background.....	644
Table_Apx G-26. Zone Names, Volumes, and Baseline Ventilation Rates	647
Table_Apx G-27. Parameters for the HBCD sources.....	650
Table_Apx G-28. Parameters for the HBCD sinks.....	650
Table_Apx G-29. Parameters for Settled Dust	651
Table_Apx G-30. Mass Balance Results for HBCD in the Simulated Home at 100 Elapsed Days.....	653
Table_Apx G-31. Parameters Used in Comparing EPS and XPS Foams.....	655
Table_Apx I-1. Noncancer Endpoints Selected for Dose-response Modeling for HBCD	665
Table_Apx I-2. Summary of BMD modeling results for T4 in F0 parental male CRL Sprague-Dawley rats exposed to HBCD by diet for 18 weeks (Ema et al. 2008); BMR = 10% RD from control mean.....	667
Table_Apx I-3. Summary of BMD modeling results for relative liver weight (g/100 g BW) in male F1 CRL rats exposed to HBCD on GD 0–PND 26, dose TWA gestation through lactation (Ema et al. 2008); BMR = 10% RD from control mean and 1 SD change from control mean.....	670
Table_Apx I-4. Summary of BMD modeling results for relative liver weight (g/100 g BW) in male CRL Sprague-Dawley rats exposed to HBCD by gavage for 13 weeks (WIL Research 2001); BMR = 10% RD from control mean and 1 SD change from control mean.....	672
Table_Apx I-5. Summary of BMD modeling results for relative liver weight (g/100 g BW) in female CRL Sprague-Dawley rats exposed to HBCD by gavage for 13 weeks (WIL Research 2001); BMR = 10% RD from control mean and 1 SD change from control mean	673
Table_Apx I-6. Summary of BMD modeling results for primordial follicles in F1 parental female CRL Sprague-Dawley rats exposed to HBCD by diet for 18 weeks (Ema et al. 2008); BMR = 1% RD from control mean, 5% RD from control mean, and 10% RD from control mean	674
Table_Apx I-7. Summary of BMD modeling results for offspring loss from PND 4 through PND 21 in F2 offspring CRL Sprague-Dawley rats; lactational doses of F1 dams (Ema et al. 2008); BMR = 1% ER and 5% ER.....	676

Table_Apx I-8. Summary of BMD modeling results for pup weight during lactation in F2 male offspring CRL Sprague-Dawley rats (PND 21) exposed to HBCD by diet for 3 weeks, lactational dose (Ema et al. 2008); BMR = 5% RD from control mean, 10% RD from control mean, 0.5 SD change from control mean, and 1 SD change from control mean	680
Table_Apx I-9. Effect of Dose on Potential Litter-Specific Covariates.....	682
Table_Apx I-10. Summary of BMD modeling results for delayed eye opening F2 female offspring CRL Sprague-Dawley rats (PND 14); F2 generation doses (Ema et al. 2008); BMR = 5% ER and 10% ER	683
Table_Apx I-11. Summary of BMD modeling results for delayed eye opening F2 female offspring CRL Sprague-Dawley rats (PND 14); F2 generation doses (Ema et al. 2008); BMR = 5% ER and 10% ER	685
Table_Apx J-1. Calculated Risk Quotients based on Estimated HBCD Surface Water Concentrations (µg/L) Using E-FAST (0% Removal)	686
Table_Apx J-2. Calculated Risk Quotients based on Estimated HBCD Surface Water Concentrations (µg/L) Using PSC (0% Removal).....	691
Table_Apx J-3. Calculated Risk Quotients based on Estimated HBCD Sediment Concentrations (µg/kg) Using PSC (0% Removal)	696
Table_Apx J-4. Calculated Risk Quotients based on Estimated HBCD Surface Water Concentrations (µg/L) Using PSC (Targeted Sensitivity Analysis Parameter: Production Volume).....	701
Table_Apx J-5. Calculated Risk Quotients based on Estimated HBCD Sediment Concentrations (µg/kg) Using PSC (Targeted Sensitivity Analysis Parameter: Production Volume)	703
Table_Apx J-6. Calculated Risk Quotients based on Estimated HBCD Surface Water Concentrations (µg/L) Using PSC (Targeted Sensitivity Analysis Parameters: Production Volume)	705
Table_Apx J-7. Calculated Risk Quotients based on Estimated HBCD Sediment Concentrations (µg/kg) Using PSC (Targeted Sensitivity Analysis Parameters: Production Volume).....	707
Table_Apx J-8 Calculated Risk Quotients based on Estimated HBCD Surface Water Concentrations (µg/L) Using PSC (Targeted Sensitivity Analysis Parameters: Production Volume)	710
Table_Apx J-9 Calculated Risk Quotients based on Estimated HBCD Sediment Concentrations (µg/kg) Using PSC (Targeted Sensitivity Analysis Parameters: Production Volume).....	713
Table_Apx J-10. Chemical Properties: Input Parameters for KABAM (v1) based on Estimated HBCD Surface Water and Sediment Concentrations (µg/kg) Using PSC.....	715
Table_Apx J-11. HBCD Hazard Data: Input Parameters for KABAM (v1).....	715
Table_Apx J-12. Calculated Risk Quotients based on KABAM (v1) based on Estimated HBCD Surface Water and Sediment Concentrations (µg/kg) Using PSC.....	716
Table_Apx J-13. Calculated Risk Quotients based on Estimated HBCD Soil Concentrations (µg/kg) Using IIOAC.....	717
Table_Apx K-1. Targeted Sensitivity Analysis Based on Production Volume for the Highly Exposed Population Following Acute Exposure	720

LIST OF APPENDIX FIGURES

Figure_Apx F-1. Depiction of the Chemical Processes in the Point Source Calculator.....	611
Figure_Apx G-1. The three-zone configuration for a generic residential setting and baseline ventilation and interzonal air flows.....	647
Figure_Apx G-2. Predicted Gas-phase HBCD Concentration in Living Area.....	651
Figure_Apx G-3. Predicted HBCD Concentration in Airborne PM in Living Area	652
Figure_Apx G-4. Predicted HBCD Concentration in Settled Dust	652
Figure_Apx G-5. Predicted HBCD Emission Rates from Polystyrene Foam Boards in Attic and Crawlspace.....	653
Figure_Apx G-6. Rate of HBCD Sorption by Gypsum Board Walls.....	653
Figure_Apx G-7. Predicted HBCD Concentrations in Vehicle's Cabin	654
Figure_Apx G-8. Predicted HBCD Concentrations in the Settled Dust in Vehicle's Cabin. The Dust Contained no HBCD Initially	654
Figure_Apx G-9. Simulated HBCD Concentrations with Different Solid-phase Diffusion Coefficients	656
Figure_Apx G-10. Comparison of Normalized Emission Rates	657
Figure_Apx I-1. Plot of mean response by dose, with fitted curve for Exponential 4 Model, for T4 in F0 parental CRL Sprague-Dawley male rats exposed to HBCD by diet for 18 weeks (Ema et al. 2008).	668
Figure_Apx I-2. Plot of mean response by dose with fitted curve for Exponential (M4) model with constant variance for relative liver weight (g/100 g BW) in F1 weanling male CRL Sprague-Dawley rats exposed to HBCD on GD 0–PND 26, dose TWA gestation through lactation (Ema et al. 2008).	670
Figure_Apx I-3. Plot of mean response by dose, with fitted curve for Exponential M4, for primordial follicles in F1 parental female CRL Sprague-Dawley rats exposed to HBCD by diet for 18 weeks (Ema et al. 2008).	675
Figure_Apx I-4. Plot of incidence rate by dose, with fitted curve for the nested logistic model where the litter specific covariate was not used and the intra-litter correlations were estimated, for incidence of offspring loss from PND 4 through PND 21 in F2 offspring CRL Sprague-Dawley rats; lactational doses of F1 dams (Ema et al. 2008).	677
Figure_Apx I-5. Plot of mean response by dose with fitted curve for Exponential (M4) model with constant variance for pup weight during lactation in F2 male offspring CRL Sprague-Dawley rats (PND 21) exposed to HBCD by diet multigenerationally, lactational dose (Ema et al. 2008).	681
Figure_Apx I-6 and Figure_Apx I-7. Plot of mean response by dose with fitted curve for Frequentist Nested Logistic Model without litter-specific covariate and with intra-litter correlation; and 0.95 Lower Confidence Limit for the BMDL in F2 female offspring CRL Sprague-Dawley rats (PND 14) exposed to HBCD multigenerationally (Ema et al. 2008). Plots display results for BMRs of 10% and 5% ER, respectively.	684
Figure_Apx I-8. Plot of mean response by dose with fitted curve for Frequentist Nested Logistic Model without litter-specific covariate and with intra-litter correlation; and 0.95 Lower Confidence Limit for the BMDL in F2 male offspring CRL Sprague-Dawley rats (PND 14) exposed to HBCD multigenerationally (Ema et al. 2008). Plot displays results for BMRs of 10% and 5% ER.	685
Figure_Apx L-1. Excerpt of Dermal Exposure Results from Repackaging of Import Containers.....	721

ACKNOWLEDGEMENTS

This report was developed by the United States Environmental Protection Agency (U.S. EPA), Office of Pollution Prevention and Toxics (OPPT), Office of Chemical Safety and Pollution Prevention (OCSPP).

Acknowledgements

The OPPT Assessment Team gratefully acknowledges participation or input from intra-agency reviewers that included multiple offices within EPA, inter-agency reviewers that included multiple Federal agencies, and assistance from EPA contractors GDIT (Contract No. CIO-SP3, HHSN316201200013W), ERG (Contract No. EP-W-12-006), Versar (Contract No. EP-W-17-006), ICF (Contract No. EPC14001), and SRC (Contract No. EP-W-12-003). The human health hazard section was developed as a cooperative effort between OPPT and the Office of Research and Development (ORD).

EPA also gratefully acknowledges the contribution of individual animal data on physical development from ([Ema et al. 2008](#)) provided by Dr. Sakiko Fujii from the Safety Research Institute for Chemical Compounds Co. Ltd. In Japan.

Docket

Supporting information can be found in the public docket: [EPA-HQ-OPPT-2019-0237](#).

Disclaimer

Reference herein to any specific commercial products, process or service by trade name, trademark, manufacturer or otherwise does not constitute or imply its endorsement, recommendation or favoring by the United States Government.

Authors

Stan Barone (Deputy Division Director), Nhan Nguyen (Management Lead), Karen Eisenreich (Management Lead), James Bressette (Staff Lead), Eva Wong (Staff Lead), Kathy Anitole, Sarah Au, Charles Bevington (formerly with EPA), Dan DePasquale, Majd El-Zoobi, Zaida Figueroa, Whitney Hollinshead, Keith Jacobs, Amuel Kennedy, Tim Lehman, David Lynch, Chantel Nicolas, Sue Slotnick, Jennifer Wills (formerly with EPA), Liang Zhang

Contributors

The human health hazard section was developed in collaboration with EPA's Office of Research and Development (ORD). The hazard section improved and expanded upon a draft IRIS assessment. The IRIS assessment has been discontinued, and a new/updated assessment will not be added to the IRIS database at this time (https://cfpub.epa.gov/ncea/iris2/chemicalLanding.cfm?&substance_nmbr=1035). EPA updated the original draft based on TSCA risk assessment practices, incorporating results of systematic review and relying on the best available science.

The IRIS assessment team for HBCD included April Luke, MS (Assessment Manager), Kathleen Newhouse, MS (Assessment Manager), Laura Dishaw, Ph.D. (Co-assessment Manager), Xabier Arzuaga, Ph.D., Christine Cai, MS, Geniece Lehmann, Ph.D., Zheng (Jenny) Li, Ph.D., and James Andre Weaver, Ph.D.

EPA would also like to acknowledge contributions by visiting scholar from Japan, Asako Hotta.

ABBREVIATIONS

°C	Degrees Celsius
7Q10	Lowest expected weekly flow over a ten-year period
atm	Atmosphere(s)
AAD	Acute Absorbed Dose
ACC	American Chemistry Council
ADC	Average Daily Concentration
ADME	Absorption, Distribution, Metabolism, and Excretion
ADR	Acute Dose Rate
AERMOD	AMS (American Meteorological Society)/EPA Regulatory Model
AF	Assessment Factor
AIC	Akaike Information Criterion
AIHA	American Industrial Hygiene Association
ALT	Alanine Aminotransferase
APF	Assigned Protection Factors
ATSDR	Agency for Toxic Substances and Disease Registry
AUC	Area Under the Curve
BAF	Bioaccumulation Factor
BALF	Bronchoalveolar lavage fluid
BCF	Bioconcentration Factor
BDE209	3,3',4,4',5,5',6,6'-decabromodiphenyl ether
bdwt	Body Weight
BLS	Bureau of Labor Statistics
BMD	Benchmark Dose Modeling
BMDL	Lower Confidence limit on the BMD
BMR	Benchmark Response
BW ^{3/4}	Body Weight Scaling to the ³ / ₄ Power
C&D	Construction and Demolition
CAA	Clean Air Act
CAD	Chronic Absorbed Dose
CASRN	Chemical Abstracts Service Registry Number
CBI	Confidential Business Information
CCL	Candidate Contaminant List
CDR	Chemical Data Reporting
CDT	1,5,9-cyclodecatriene
CEPA	The Center for European Policy Agency
CFR	Code of Federal Regulations
CHAD	Consolidated Human Activity Database
COC	Concentration of Concern
COU	Condition of Use
CPSC	Consumer Product Safety Commission
CSCL	Chemical Substance Control Law
CT	Central Tendency
DAF	Dosimetric Adjustment Factor

DBCD	9,10-dibromocyclododeca-1,5-diene
DEE	Data Extraction and Evaluation
DMF	Dimethylformamide
DMSO	Dimethyl sulfoxide
Dwt	Dry weight
EASE	Estimation and Assessment of Substance Exposure
EC	European Commission
EC50	Median Effective Concentration
ECB	European Chemicals Bureau
ECHA	European Chemicals Agency
EC/HC	Environment Canada / Health Canada
ECOTOX	ECOTOXicology knowledgebase
E-FAST	Exposure and Fate Assessment Screening Tool
EINECS	European Inventory of Existing Commercial Substances
EPCRA	Emergency Planning and Community Right-to-Know Act
EPS	Expanded Polystyrene
EPS-IA	Expanded Polystyrene Industry Alliance
ER	Extra Risk
ESD	Emission Scenario Document
EU	European Union
EURAR	European Union Risk Assessment Report
FR	Federal Register
FOB	Functional Occupational Battery
g	Gram(s)
GI tract	Gastrointestinal tract
GM	Geometric Mean
GS	Generic Scenario
GSH	Glutathione
GST	Glutathione-S-transferase
HAP	Hazardous Air Pollutant
HBCD/HBCDD	Hexabromocyclododecane
HED	Human Equivalent Dose
HERO	Health and Environmental Research Online
HE	High-End
HIPS	High Impact Polystyrene
HPLC	High Performance Liquid Chromatography
HQ	Headquarters
hr	Hour
IECCU	Indoor Environmental Concentrations in Buildings with Conditioned and Unconditioned Zones
IIOAC	Integrated Indoor-Outdoor Air Calculator
Ind	Industrial
KABAM	KOW(based) Aquatic BioAccumulation Model
KLH	Keyhole limpet Hemocyanin
kg	Kilogram(s)

Koa	Octanol:Air Partition Coefficient
L	Liter(s)
lb	Pound
LADC	Lifetime Average Daily Concentration
LCD	Liquid-Crystal Display
LC/MS	Liquid Chromatography-Mass Spectrometry
LOQ	Level of Quantitation
LOAEL	Lowest Observed Adverse Effect Level
LOEC	Lowest Observed Effect Concentration
Log Koc	Logarithmic Organic Carbon:Water Partition Coefficient
Log Kow	Logarithmic Octanol:Water Partition Coefficient
LPO	Lipid Peroxidation
m ³	Cubic Meter(s)
MATC	Maximum Acceptable Toxicant Concentration
MFG	Manufacture
MLD	Million Liters per Day
mmHg	Millimeter(s) of Mercury
MOA	Mode of Action
MOE	Margin of Exposure
MOEJ	Ministry of Environment Government in Japan
MSW	Municipal Solid Waste
MSWLF	Municipal Solid Waste Landfills
MT	Metric Tons
N/A	Not Applicable
NAICS	North American Industry Classification System
ND	No Data
NICNAS	National Industrial Chemicals Notification and Assessment Scheme
NIOSH	National Institute for Occupational Safety and Health
NITE	National Institute of Technology and Evaluation
NOAEL	No Observable Adverse Effect Level
NOEC	No Observed Effect Concentration
NR	Not Reported
NRC	National Research Council
OARS	Occupational Alliance for Risk Science
OECD	Organisation for Economic Co-operation and Development
OEL	Occupational Exposure Limits
OES	Occupational Exposure Scenario
ONU	Occupational Non-User
OPPT	Office of Pollution Prevention and Toxics
OSHA	Occupational Safety and Health Administration
P	Persistence
P&CB	Public and Commercial Buildings
PAPR	Power Air-Purifying Respirator
PBDE	Polybrominated Diphenyl Ether
PBPK/PD	Physiologically Based Pharmacokinetic / Pharmacodynamic

PBZ	Personal Breathing Zone
PDM	Probabilistic Dilution Model
PEC	Predicted Environmental Concentration
PECO	Populations, Exposures, Comparators and Outcomes
PESO	Pathways and Processes, Exposure, Setting or Scenario, and Outcomes
PESS	Potentially Exposed or Susceptible Subpopulations
PM	Particulate Matter
PND	Post-Natal Day
PNOR	Particles Not Otherwise Regulated
POD	Point of Departure
POPs	Stockholm Convention on Persistent Organic Pollutants
POTW	Publicly Owned Treatment Works
ppm	Part(s) per Million
PQL	Practical Quantitation Limit
PTF	Post Fertilization
PV	Production Volume
QC	Quality Control
RAR	Risk Assessment Report
RCRA	Resource Conservation and Recovery Act
RD	Relative Deviation
REACH	European Union's Registration, Evaluation, Authorisation and Restriction of Chemicals
RESO	Receptors, Exposures, Setting or Scenario, and Outcomes
ROS	Reactive Oxygen Species
SAR	Supplied-Air Respirator
SCBA	Self-Contained Breathing Apparatus
SCCH	Stockholm Convention Clearing House
SD	Standard Deviation
SHGB	Sex Hormone Binding Globulin
SIAP	Screening Information Dataset Initial Assessment Profile
SIC	Standard Information Panels
SIDS	Screening Information dataset
SIPS	Structural Insulated Panels
site-yr	Site-year
SNUN	Significant New Use Notice
SNUR	Significant New Use Rule
SOC	Standard Occupational Classification
SOD	Superoxide dismutase
SPF	Spray polyurethane foam
SUSB	Statistics of U.S. Businesses
SVHC	Substance of Very High Concern
SWC	Surface Water Concentration
T	Toxicity
TBCD	5,6,9,10-tetrabromocyclododec-1-ene
TGD	Technical Guidance Document
TLV	Threshold Limit Value

TOC	Total Organic Carbon
TRI	Toxics Release Inventory
TSCA	Toxic Substances Control Act
TSH	Thyroid Stimulating Hormone
TURA	Toxics Use Reduction Act
TWA	Time-Weighted Average
UF	Uncertainty Factor
U.S.	United States
UNEP	United Nations Environment Programme
vB	Very Bioaccumulative
VVWM-PSC	Variable Volume Water Model - Point Source Calculator
WEEE	Waste Electrical and Electronic Equipment
WEEL	Workplace Environmental Exposure Level
WOE	Weight of the Scientific Evidence
WSDE	Washington State Department of Ecology
WWT/WWTP	Wastewater Treatment Plant
XPS	Extruded Polystyrene (<i>i.e.</i> , Extruded Polystyrene foam)
XPSA	Extruded Polystyrene Association
Yr	Year

EXECUTIVE SUMMARY

This Risk Evaluation for cyclic aliphatic bromide cluster chemicals, including hexabromocyclododecane (HBCD), was performed in accordance with the Frank R. Lautenberg Chemical Safety for the 21st Century Act and is being issued following public comment and peer review. The Frank R. Lautenberg Chemical Safety for the 21st Century Act amended the Toxic Substances Control Act (TSCA), the nation's primary chemicals management law, in June 2016. Under the amended statute, EPA is required, under TSCA Section 6(b), to conduct risk evaluations to determine whether a chemical substance presents an unreasonable risk of injury to health or the environment, under the conditions of use, without consideration of costs or other non-risk factors, including an unreasonable risk to potentially exposed or susceptible subpopulations identified as relevant to the Risk Evaluation. Also, as required by TSCA Section 6(b), EPA established, by rule, a process to conduct these Risk Evaluations, [Procedures for Chemical Risk Evaluation Under the Amended Toxic Substances Control Act \(82 FR 33726\)](#) (Risk Evaluation Rule). This Risk Evaluation is in conformance with TSCA Section 6(b) and the Risk Evaluation Rule, and is to be used to inform risk management decisions. In accordance with TSCA Section 6(b), if EPA finds unreasonable risk from a chemical substance under its conditions of use in any final Risk Evaluation, the Agency will propose actions to address those risks within the timeframe required by TSCA. However, any proposed or final determination that a chemical substance presents unreasonable risk under TSCA Section 6(b) is not the same as a finding that a chemical substance is "imminently hazardous" under TSCA Section 7. The conclusions, findings, and determinations in this final Risk Evaluation are for the purpose of identifying whether the chemical substance presents unreasonable risk under the conditions of use, in accordance with TSCA Section 6, and are not intended to represent any findings under TSCA Section 7.

TSCA Section 26(h) and (i) require EPA, when conducting Risk Evaluations, to use scientific information, technical procedures, measures, methods, protocols, methodologies and models consistent with the best available science and base its decisions on the weight of the scientific evidence.¹ To meet these TSCA Section 26(h) science standards, EPA used the TSCA systematic review process described in the [Application of Systematic Review for TSCA Risk Evaluations](#) document ([U.S. EPA 2018b](#)). The data collection, data evaluation and data integration stages of the systematic review process are used to develop the exposure, fate and hazard assessments for the risk evaluations.

The cyclic aliphatic bromide cluster chemicals, including HBCD (Chemical Abstracts Service Registry Number [CASRN] 25637-99-4), 1,2,5,6,9,10-hexabromocyclododecane (1,2,5,6,9,10-HBCD; CASRN 3194-55-6) are flame retardants. Conditions of use for 1,2,5,6-tetrabromocyclooctane (CASRN 3194-57-8), another chemical in the cyclic aliphatic bromide cluster, were not identified. For the purposes of this final Risk Evaluation document, the use of "HBCD" refers to either CASRN 25637-99-4 or 3194-55-6, or both. The primary use of HBCD has been as a flame retardant in expanded polystyrene and extruded polystyrene; however, EPA identified other uses including use as a component of solder and use in automobile replacement parts.

HBCD is a persistent, bioaccumulative and toxic (PBT) substance that exists as a non-volatile solid (Section 1.1). HBCD released to the environment remains unchanged for months or longer and accumulates in aquatic and terrestrial organisms including humans. Because of these characteristics, even low levels of HBCD move through aquatic and terrestrial food chains from lower to higher levels

¹ Weight of the scientific evidence is defined in EPA regulations as a systematic review method, applied in a manner suited to the nature of the evidence or decision, that uses a pre-established protocol to comprehensively, objectively, transparently, and consistently identify and evaluate each stream of evidence, including strengths, limitations, and relevance of each study and to integrate evidence as necessary and appropriate based upon strengths, limitations, and relevance. 40 CFR 702.33.

and result in increasing concentrations in aquatic and terrestrial life higher in the food chain (Section 2.1). In contrast to chemicals that do not exhibit PBT characteristics, ecological impacts due to trophic level transfer of HBCD and human dietary exposure pathways to HBCD including fish ingestion are considered. Background levels of HBCD have been measured in a variety of environmental media and biota, in indoor air and dust, and in human milk, blood, and urine. Due to HBCD's persistence, humans and environmental organisms can be exposed to background levels that stem from past activities at the five stages in the life of the chemical, *i.e.*, manufacture (including import), processing, distribution, use, and disposal. Releases of HBCD could have resulted from activities that still occur or from releases associated with uses that phased out of all life stages. These characteristics and their impacts on environmental and human exposure to HBCD were important considerations in the HBCD Risk Evaluation. EPA considered a variety of exposure pathways for HBCD to workers, general population, consumers, and the environment, although certain pathways may have undergone minimal evaluation based on assessment of physical-chemical properties or other considerations such as existing EPA regulations (see Section 1.4).

The production (domestic manufacturing and importation) and use of HBCD has rapidly declined in the U.S. and globally over the past 10 years due to international regulation and the availability of substitutes. Annual production volumes were consistently 10-50 million lbs from 2007 to 2011. From 2012 to 2015, production fell to 1-10 million lbs/year. Additional communications with industry representatives indicate that, as of 2018, domestic manufacture of HBCD has ceased and there are currently no U.S. manufacturers of the chemical. Use of stockpiles and exportation from the United States was completed at the end of 2017 and is further discussed in Section 1.2.2 of this final Risk Evaluation. Under the United Nations Stockholm Convention on Persistent Organic Pollutants, 171 of the 188 Party countries have agreed to ban the production, use, import, and export of HBCD, consistent with the obligations of the Convention. The United States is not a signatory to the Convention. Furthermore, substitutes have been adopted in the market. For example, Dow Chemical developed the polymeric flame retardant that replaced HBCD for use in insulation boards used in construction. The product is licensed to other manufacturers including Albemarle, Chemtura, and Bromine Compounds Limited (part of ICL Industrial Products); these companies sell the chemical under different trade names.

EPA has not identified reasonably available information to suggest that HBCD is currently domestically manufactured in any quantity. Consideration of the status of manufacturing, availability of viable substitutes and the strong international regulatory focus on phasing out of manufacturing, use and international trade in HBCD has led EPA to believe the domestic manufacturing of HBCD is not known, intended or reasonably foreseen to occur.

Based on information received by industry associations and member companies, historic major importers have since 2017 ceased importation of the chemical. It is reasonably foreseen, however, that foreign manufacturers in countries that have not agreed to the Stockholm ban or are non-signatories of the Convention are or will be in the future producing HBCD that could be imported in quantities below CDR reporting thresholds. For these reasons, EPA has included the import of HBCD in the final Risk Evaluation.

The primary use of HBCD in the United States historically has been as a flame retardant in XPS/EPS insulation foam used in construction. This use had accounted for 95% of all HBCD applications in the past decade. Based on information from a market report, HBCD was used primarily in construction materials, which may have included structural insulated panels (SIPS).

Although some of the industry comments on the draft Risk Evaluation indicate with more certainty than previous comments that the phaseout of HBCD for XPS/EPS insulation foam is complete, the industry associations do not represent every possible importer and processor of HBCD. Taking into account the high percentage of HBCD production volume dedicated to these two uses in previous years, and the fact that companies have the ability to import the chemical in low volumes below the CDR reporting threshold, EPA believes that it is reasonably foreseen that EPS and XPS Association non-members currently are or will in the future be using imported HBCD-containing resins in their processes. EPA therefore included the processing and use of HBCD in XPS and EPS insulation in the final Risk Evaluation.

In addition to the major use of HBCD in insulation, much smaller quantities have been processed into products and articles including automotive replacement parts, solder paste, electrical and electronic products, textiles, adhesives, and coatings. These six products and articles are considered conditions of use (COUs). As the chemical has declined in importance, the only remaining processing of HBCD into products and articles is for automotive replacement parts and solder paste. Manufacture, processing, use, and distribution of HBCD for the other four products and articles have phased out, although commercial/consumer use and disposal still occur. For the four minor products for which manufacturing, processing, use and distribution have been phased out, the final RE adds two COUs: Use in other formulated products and articles (*e.g.*, textiles, electrical and electronic products, adhesives, and coatings) and Disposal of other formulated products and articles (*e.g.*, textiles, electrical and electronic products, adhesives, and coatings). All six minor use products and articles are included as COUs in this final Risk Evaluation.

Reused and recycled EPS and XPS foam insulation board, siding, roof membrane and roofing ballast material are available in the United States. Two companies were identified that directly reuse (*e.g.*, reuse without reforming) and recycle (*e.g.*, melting and inserting into the manufacturing process) XPS and EPS foam insulation. Once processed, recycled EPS roofing insulation is taken to polystyrene product manufacturers, notably picture frame manufacturers, mostly in China. Recycled roofing material is also sent to other EPS recycling plants that may use different processes. XPS roofing material is reused due to the special equipment needed to recycle XPS. The recycling of HBCD-containing EPS and reuse of XPS insulations boards for use in construction materials is included as a COU in this final Risk evaluation.

While only anecdotal information is available indicating HBCD use in high impact polystyrene (HIPS) in electronics occurred in the United States (Section 1.2), there are more substantial data from the EU indicating a range of between 2 and 7 percent of HBCD production volume in Europe was historically used in HIPS and that the majority of HIPS was used in electronics. This makes it likely that electronics products with HBCD-containing HIPS have been imported into the United States in past years. EPA believes that it is reasonably foreseen that HBCD may be present in recycling of electronics waste and therefore included this condition of use, called recycling of electronics waste containing HIPS that contain HBCD, in this final Risk Evaluation. Previously, EPA inadvertently omitted recycling of electronics waste in the draft Risk Evaluation.

The draft Risk Evaluation contained a COU for consumer use of recycled consumer articles which was inadvertently left off the list of COUs in Table 1-8. The COU is inserted into Table 1-8 of this final Risk Evaluation.

EPA previously described three specific scenarios under which the Agency could determine to exclude certain conditions of use from chemical risk evaluations: legacy uses, associated disposal, and legacy

disposal. By legacy use, EPA referred to circumstances associated with activities that do not reflect ongoing or prospective manufacturing, processing, or distribution. By associated disposal, EPA referred to future disposal from legacy uses. By legacy disposal, EPA referred to disposals that have already occurred. In the rule, “EPA interpret[ed] the mandates under Section 6(a)-(b) to conduct risk evaluations and any corresponding risk management to focus on uses for which manufacturing, processing, or distribution in commerce is intended, known to be occurring, or reasonably foreseen to occur (*i.e.*, is prospective or on-going), rather than reaching back to evaluate the risks associated with legacy uses, associated disposal, and legacy disposal, and interprets the definition of ‘conditions of use’ in that context.” (82 FR 33730) As a result, EPA did not include any legacy uses, associated disposals, or legacy disposals as conditions of use within the scope of the Risk Evaluations for the first 10 chemicals undergoing the new TSCA Risk Evaluation process.

However, some stakeholders disagreed with this interpretation and challenged the final Risk Evaluation Rule in court. In 2019, the Ninth Circuit Court of Appeals ruled that EPA cannot categorically exclude “legacy use” and “associated disposal” from the definition of “conditions of use” (*Safer Chemicals, Healthy Families v. U.S. Env'tl. Prot. Agency*, 943 F.3d 397, 425 (9th Cir. 2019)). As a result of the court’s opinion, EPA will no longer exclude legacy use or associated disposal from the definition of conditions of use for chemical risk evaluations. Rather, when these activities are intended, known, or reasonably foreseen, they will be considered uses and disposal, respectively, within the definition of conditions of use. Thus, in conducting a Risk Evaluation, certain parts of the lifecycle for a given COU may not be evaluated because those parts are not intended, known, or reasonably foreseen. For example, if the manufacture (including import), processing and distribution parts of the life cycle are not intended, known, or reasonably foreseen, then the evaluation will only consider the uses and disposal stages of the lifecycle to be COUs. The court did not rule against EPA’s exclusion of legacy disposal from scopes of risk evaluations.

Prior to the court ruling on *Safer Chemicals, Healthy Families v. U.S. Env'tl. Prot. Agency*, at the beginning of the Risk Evaluation process for HBCD, EPA had information indicating that a small percentage of the chemical’s production volume (less than 5%) had been used in the past in the processing of four products and articles. The items were adhesives, coatings, electronics, and textiles. HBCD is no longer manufactured, processed, or distributed in commerce as part of the four products and articles. In accordance with the final Risk Evaluation Rule, EPA considered activities involving these products and articles to be “legacy uses” and “associated disposal” and excluded the activities from the scope of the August 2019 draft HBCD Risk Evaluation. Later that year, the court made its ruling in *Safer Chemicals Healthy Families v. U.S. Env'tl. Prot. Agency*. Because of the court ruling, as well as public and SACC review comments, EPA is no longer excluding the four products and articles in the Risk Evaluation. Although manufacturing, processing, and distribution in commerce of HBCD in the products and articles has ended, commercial/consumer use and associated disposal are still occurring and these activities are COUs in the final risk evaluation. EPA evaluated exposure to these use and disposal activities and has made a determination for each COU on whether exposure presents unreasonable risk. Legacy disposal of HBCD, *i.e.* disposal that occurred in the past, is not a COU. Likewise, other activities in the HBCD lifecycle stages that occurred in the past are not COUs, although EPA has evaluated exposure to background levels of HBCD resulting from past activities that left HBCD in environmental media and indoor air and dust. EPA did not exclude any activity determined to be a COU.

The conditions of use evaluated for HBCD, as further described in Section 1.4.1 of the final Risk Evaluation for HBCD, include:

- Importation of HBCD
- Processing of flame retardants: use in custom compounding of resin and solder paste
- Processing of flame retardants: use in manufacture of XPS and EPS foam; use in manufacture of structural insulated panels; use in automobile replacement parts from XPS and EPS foam
- Processing: recycling of XPS and EPS foam, resin, panels containing HBCD; electronics waste
- Processing: recycling of electronics waste containing HIPS that contains HBCD
- Distribution: activities related to distribution
- Use in building and construction materials
- Use in automobile replacement parts
- Use in plastic and other articles
- Use in other formulated products and articles, *e.g.*, adhesives, coatings, textiles, and electronics
- Disposal of construction and demolition waste
- Disposal of other formulated products and articles, *e.g.*, adhesives, coatings, textiles, and electronics

Approach

EPA used reasonably available information² in a fit-for-purpose approach, to develop a risk evaluation that relies on the best available science and is based on the weight of the scientific evidence. EPA used previous assessments as a starting point for identifying key and supporting studies to inform the exposure, fate, and hazard assessments. EPA also evaluated other studies published since the publication of any previous analyses. EPA reviewed reasonably available information and evaluated the quality of the methods and reporting of results of the individual studies using the evaluation strategies described in *Application of Systematic Review in TSCA Risk Evaluations* ([U.S. EPA 2018b](#)). To satisfy requirements in TSCA Section 26(j)(4) and 40 CFR 702.51(e), EPA has provided a list of studies considered in carrying out the Risk Evaluation, and the results of those studies are included in the Systematic Review Data Quality Evaluation/Extraction Documents (see Appendix B, items 6 and 7).

In the problem formulation, EPA identified the conditions of use within the scope of the risk evaluation and presented three conceptual models and an analysis plan for this Risk Evaluation ([U.S. EPA 2018g](#)). These have been carried into the Risk Evaluation where EPA has quantitatively evaluated the risk to the environment and human health, using both monitoring data and modeling approaches, for the conditions of use (identified in Section 1.4.1 of this risk evaluation). EPA quantitatively evaluated the risk to aquatic (pelagic and benthic) and terrestrial organisms from exposure to surface water, sediment and soil (via air deposition) as a result of the manufacturing, processing, use, or disposal of HBCD. EPA evaluated risk to workers, from inhalation and dermal exposures (EPA was unable to quantitatively evaluate risk to occupational non-users (ONUs)³, by comparing the estimated acute and chronic exposures to human health hazards (*e.g.*, thyroid effects, liver effects, reproductive effects, developmental effects). EPA also evaluated the risk to the general population and consumers from acute and chronic inhalation, dermal, and oral exposures.

EPA used environmental fate parameters, physical-chemical properties, monitoring data and modeling approaches to assess exposure to aquatic organisms, and sediments and soil exposure to terrestrial species. The exposure and environmental hazard analyses for these environmental release pathways was conducted based on a quantitative assessment of predicted environmental concentrations of HBCD in

² Defined in 40 CFR 702.33 in part as “information that EPA possesses, or can reasonably obtain and synthesize for use in risk evaluations, considering the deadlines ...for completing the evaluation...”.

³ ONUs are workers who do not directly handle HBCD but perform work in an area where HBCD is present.

surface water, sediment, and soil. These exposure analyses are detailed in Section 2.1 through 2.3.5 and environmental hazards are discussed in Section 3.1 for aquatic and terrestrial organisms.

EPA evaluated potential occupational exposures to HBCD that result from the conditions of use that are in the scope of this Risk Evaluation as listed in Section 1.4 (Scope of the Evaluation). EPA evaluated potential acute and chronic inhalation and dermal exposures to workers. EPA estimated potential inhalation exposure concentrations based on HBCD worker inhalation monitoring data that EPA obtained via a systematic review of the literature. In the case of some occupational exposure scenarios, EPA's systematic review of the literature did not result in worker inhalation monitoring data and EPA estimated potential inhalation exposure concentrations in accordance with other estimation methods. EPA's systematic review did not result in any HBCD worker dermal monitoring data and EPA estimated dermal exposures in accordance with modeling approaches. EPA did not quantitatively evaluate inhalation exposures of ONUs to HBCD due to lack of adequate, reasonably available, worker monitoring data and lack of relevant mathematical models. The occupational exposure evaluation is described in detail in Section 2.4.1. In this Risk Evaluation, consumer exposures were evaluated for individuals who have articles containing HBCD in their homes or automobiles. The consumer exposure assessment also includes the mouthing of consumer articles that contained HBCD. The consumer exposure evaluation is described in detail in Section 2.4.4.

HBCD is present and persistent in various environmental media such as surface water, sediment, soil and air. EPA quantitatively evaluated inhalation, ingestion and dermal exposures to the general population via exposure to indoor and ambient air; dermal contact with soil and dust and oral exposures via ingestion of food, breast milk, soil, dust and fish. While HBCD is released to surface water, EPA determined during problem formulation that no further analysis beyond what was presented in the problem formulation document would be done for the drinking water exposure pathway in this Risk Evaluation. While this exposure pathway remains in the scope of the risk evaluation, EPA found no further analysis was necessary. Further analysis was not conducted for the drinking water pathway based on a qualitative assessment of the physical chemical properties and fate of HBCD in the environment as well as the absence of any detection of HBCD in monitored water samples.

While environmental exposures are expected to decline as importing and processing of the chemical are being phased out, based on past production volumes (millions of pounds per year) and the fact that cessation of domestic manufacturing is recent, reductions in environmental and biological concentrations will likely occur gradually over a period of time for this persistent and bioaccumulative compound. The time scales for this are dependent on the age of the products, their useful service lives and timelines for replacement.

EPA also evaluated background exposures in calculating risk estimates for the environment and general population, representing chronic, steady-state risks from sustained background exposure in the environment due to HBCD's persistence. These exposures cannot be associated with any particular COU or past use and it is unknown which combination of potential sources associated with evaluated COUs or past uses contribute to this background exposure. These background exposures were considered independently of COU-specific releases within exposure routes but were also aggregated across different exposure routes when applicable (*i.e.*, for human health). The totality of background exposure includes steady-state environmental exposures from ongoing releases not associated with a particular COU, and releases stemming from historical activities (Section 1.2.9) due to HBCD's persistence in the environment. Historical activities are past activities that may have released HBCD but no longer occur (*e.g.*, releases from a manufacturing plant before it stopped producing HBCD, residual indoor dust from formerly owned HBCD-containing products, legacy disposal).

In the absence of reasonably available information on product-specific releases, cumulative background exposure was also used as a surrogate for assessing the COUs for use and disposal of formulated products (e.g., adhesives and coatings) and articles (e.g., textiles, electrical and electronic products), minor-use products, and articles which are no longer manufactured, processed, or distributed. While EPA cannot determine COU-specific releases or exposures for these products/articles, they are expected to contribute to background exposure and would therefore comprise a subset of the total background exposure levels. The amount of HBCD in the subset of background exposure levels is unknown, but the risk estimation of exposure to the total background levels of HBCD is an upper bound and therefore constitute a conservative risk characterization for the two COUs.

EPA reviewed the environmental hazard data using the data quality review evaluation metrics and the rating criteria described in the *Application of Systematic Review in TSCA Risk Evaluations* ([U.S. EPA 2018b](#)). EPA concluded that HBCD poses a hazard to environmental aquatic and terrestrial receptors. Hazard thresholds for aquatic organisms were derived using algae, fish and invertebrates, as a result of acute and chronic exposures. Similarly, maize, earthworms, kestrel, osprey and rats were used to derive hazard thresholds for terrestrial organisms due to both acute and chronic exposures to HBCD. The results of the environmental hazard assessment are in Section 3.1.

In the human hazard section, EPA evaluated reasonably available information and identified hazard endpoints including acute/chronic toxicity, non-cancer effects, associated with inhalation, oral and dermal exposures. EPA used an approach based on the *Framework for Human Health Risk Assessment to Inform Decision Making* ([U.S. EPA 2014e](#)) to evaluate, extract and integrate HBCD's human health hazard and dose-response information. EPA reviewed key and supporting information from previous hazard assessments as well as the existing body of knowledge on HBCD's human health hazards. These data sources included the TRI Technical Review of HBCD ([U.S. EPA 2016e](#)), the *TSCA Work Plan Problem Formulation and Initial Assessment*, ([U.S. EPA 2015a](#)), *Preliminary Materials for the IRIS Toxicological Review of HBCD* ([U.S. EPA 2014f](#)) as well as other publications ([U.S. EPA 2016e](#), [2014d](#); [NICNAS 2012a](#); [EC/HC 2011](#); [EINECS 2008](#); [U.S. EPA 2008a](#); [OECD 2007](#)).

EPA considered adverse effects for HBCD across organ systems. EPA considered data on toxicity following acute and chronic exposures, for irritation, sensitization, genotoxicity, reproductive, developmental and other systemic toxicity and carcinogenicity. From these effects, the EPA selected endpoints supported by the evidence for non-cancer that were amenable to quantitative analysis for dose-response assessment as discussed in more detail in Section 3.2.5. Based on the weight of the scientific evidence evaluation, four health effect domains were selected for non-cancer dose-response analysis: (1) thyroid; (2) liver; (3) female reproductive; and (4) developmental. These hazards were carried forward for dose-response analysis. Given the different HBCD exposure scenarios considered (both acute and chronic), different endpoints were considered for risk estimation based on the expected exposure durations. The results of the human hazard assessment are in Section 3.2.

Risk Characterization

Environmental Risk: For environmental risk, EPA utilized a risk quotient (RQ) to compare the environmental concentration to the effect level to characterize the risk to aquatic and terrestrial organisms. As described in Section 3.1.5, the environmental hazard thresholds are based on environmental hazard concentrations reported for both aquatic and terrestrial organisms. The algae concentration of concern (COC) is based on observed reductions in growth rate as a result of a 72-hour exposure to HBCD. The acute COC is based on delayed zebrafish embryo hatching as a result of a 96-

hour exposure to HBCD. Finally the chronic COC for pelagic (water flea) and benthic (California blackworm) invertebrates are based on reduced growth in surviving young and a reduction in worm number, respectively. Hazard thresholds used to characterize risk for terrestrial soil organisms include effects regarding reproduction and mortality in earthworms exposed to HBCD for 56 days.

HBCD is a persistent, bioaccumulative and toxic (PBT) chemical, and is expected to be present in surface water, sediment and soil. To characterize HBCD exposure in aquatic and terrestrial environments, both environmental modeling and monitoring data were used to provide media-specific concentrations of HBCD. To characterize environmental risk associated with a COU, models were used to estimate environmental concentrations of HBCD (*e.g.*, surface water, sediment, soil via air deposition), where the predicted HBCD releases associated with exposure scenarios depend on many factors (*e.g.*, days of release, HBCD half-life). Environmental monitoring information provides time and geographically-specific snapshots of measured concentrations of HBCD that are not linked to a specific, identified current or past industrial or commercial activity. Environmental monitoring information supports the estimated HBCD concentrations associated with various conditions of use, and both types of environmental exposure estimates are used to derive environmental risk. The results of the risk characterization are in Section 4.1.4, and Table 4-25 summarizes the RQs for aquatic and terrestrial organisms.

EPA identified the expected environmental exposures for aquatic and terrestrial species under the conditions of use in the scope of the risk evaluation. Estimated releases from specific exposure scenarios result in modeled surface water and sediment concentrations that exceed the aquatic benchmark ($RQ \geq 1$) for acute, chronic and/or algae COC for every COU except for disposal, where only the chronic COC for benthic invertebrates was not exceeded (acute, chronic and algae COCs for pelagic organisms were exceeded and environmental risks were indicated). Furthermore, surface water and sediment HBCD concentrations measured near industrial facilities also exceeded acute, chronic and/or algae COCs, whereas those measured near general population sites did not. In regard to the characterization of risk to terrestrial organisms, there were no HBCD soil concentrations attained from modeled or monitoring data that exceeded the chronic COC. Details of these estimates are in Section 4.5.1.

Risks to aquatic organisms were identified for every COU with water releases, based on exceedances of COCs for pelagic and/or benthic organisms. EPA found it unlikely that there may be risks of concern for terrestrial soil organisms based on the air releases of HBCD associated with the conditions of use.

Human Health Risks: Risks were estimated for all human receptors following both acute and chronic exposure for representative endpoints from every hazard domain carried through to dose-response analysis. Risks for acute exposures were only evaluated for developmental endpoints, while all endpoints were evaluated for chronic risks. Risk conclusions were based on the most robust and sensitive acute (offspring loss) and chronic (thyroid hormone effects) endpoints. Thyroid hormone changes (both acute and chronic) are considered the primary effect resulting from HBCD exposure, as they are associated with all of the other observed downstream endpoints.

EPA estimated potential non-cancer risks resulting from acute and chronic inhalation and dermal exposures using a Margin of Exposure (MOE) approach. EPA estimated risks for workers under several occupational exposure scenarios using scenario-specific assumptions regarding the expected use of personal protective equipment (PPE) for respiratory and dermal exposures for workers directly handling HBCD. More information on respiratory and dermal protection, including EPA's approach regarding the occupational exposure scenarios for HBCD, is in Section 2.4.1.

For acute and chronic exposures via inhalation without PPE (*i.e.*, no respirators), risks are indicated for workers relative to the benchmarks for multiple occupational exposure scenarios (OES). There are risks at both high-end and central tendency exposure levels relative to benchmark for four OES, and there are risks based on high-end inhalation exposure levels for another six OES. With use of PPE during relevant conditions of use, worker exposures were estimated to be reduced. This resulted in fewer conditions of use with estimated acute, chronic non-cancer, or cancer inhalation or dermal risks. With use of respiratory protection, non-cancer risks were not indicated for any conditions of use within the scope of the risk evaluation. Specifically, when respirators are worn (APF 5, 10, or 50), risks are not indicated for both acute and chronic exposure durations at both high-end and central tendency exposure levels. Workers exposed through *Installation or Demolition of XPS/EPS Foam Insulation* are unlikely to wear respiratory protection. Therefore, when considering assumed use of PPE, risks are indicated only for those two OES. Risks were not indicated at either high-end or central tendency exposure levels for *Processing of HBCD to produce XPS foam using XPS Masterbatch*, *Occupational microenvironments*, and *Recycling of electronics waste containing HIPS*. Occupational non-users (ONUs) are assumed to have lower exposure levels than workers in most instances but exposures could not be quantified. Exposures are site-specific and are depended on several site-specific factors including engineering controls, work practices, and particle size. Also, EPA did not identify any peer-reviewed models that can be used to estimate exposures for ONUs for these specific scenarios.

For acute and chronic exposures via dermal contact without PPE (*i.e.*, no gloves) risks are indicated for workers relative to the benchmark for multiple OES, with risks at both high-end and central tendency exposure levels for five OES. Risks are indicated based only on chronic exposure at the high-end exposure level for a single OES, *Use of flux/solder paste*. EPA does not expect any level of dermal exposure to HBCD following proper use of impervious gloves (Section 2.4.1.1). Therefore, risk estimates are not provided, and risks are not identified for any exposure scenario when impervious gloves are worn and used appropriately. EPA did not evaluate ONU dermal exposure to HBCD since they are not expected to handle the chemical. ONUs are potentially exposed to HBCD dermally through contact with surfaces where HBCD dust has settled but EPA did not quantify these risks due to minimal exposure.

For the general population, EPA estimated non-cancer risks resulting from chronic aggregate background exposure via all relevant pathways including dust, soil, indoor air, diet, and dermal pathways (Section 4.2.3.1). Risks were also estimated based on a subset of aggregate background exposures for workers in occupational microenvironments (Section 4.2.3.1.1). For the most sensitive highly exposed general population (a Potentially Exposed or Susceptible Subpopulations (PESS) group who are expected to live close to facility or residential HBCD sources, see Section 2.4.3), EPA estimated non-cancer risks resulting from acute or chronic exposures via inhalation or fish ingestion (Section 4.2.3.3). For highly exposed general population risk estimation, EPA incorporated summed exposures from representative fish ingestion or air inhalation modeled exposures and the aggregate central tendency general population biomonitoring-based exposures (representing background exposure) for all other exposure routes. Risks were estimated based on the highest and representative moderate exposure sub-scenarios representing variability in estimated releases and wastewater treatment. Risks were also estimated for consumers based on indoor air and dust exposure and aggregated background exposures from other routes. Risks were indicated relative to benchmark only for a single OES at the highest exposure sub-scenario, via acute fish ingestion (Table 4-21). For all other exposure scenarios, risk estimates were several fold above the benchmark and risk is not expected. Based on qualitative consideration of the physical-chemical and fate characteristics as well as low concentrations in surface

water and the absence of any monitored levels in drinking water, HBCD is not expected to be present in drinking water. Therefore, risks were not identified for HBCD via drinking water exposure.

EPA additionally calculated distinct risk estimates for various PESS groups including subsistence fishers (a group that ingests elevated levels of fish compared to the general population) and newborns less than 1 year old (who are not expected to ingest fish) based on chronic high-end aggregate background exposure (Table 4-29). Additional details on risk considerations for all PESS groups are described in Section 4.4.1. Risk estimates did not indicate risk relative to the benchmark for either of these two highly-exposed receptor groups.

Uncertainties: Key assumptions and uncertainties in the environmental risk estimation are related to data used for the characterization of environmental exposure (*e.g.*, model input parameters, inability to directly relate monitoring sites to conditions of use) and environmental hazard (*e.g.*, selection of representative organisms, allometric-scaling to estimate hazard thresholds for other organisms). Additionally, the reasonably available environmental monitoring data was limited temporally and geographically. Assumptions and key sources of uncertainty in the risk characterization are detailed in Section 4.3.1.

For the human health risk estimation, key assumptions and uncertainties are related to the toxicokinetics of HBCD, including high-end assumptions about dermal absorption and uncertainty whether existing UFs sufficiently account for bioaccumulation in human tissues. Additional sources of uncertainty related to human health hazard include the application of adult rodent thyroid hormone changes to humans in a developmental context and the absence of reliable dose-response information for developmental neurotoxicity endpoints. EPA also considered differing assumptions about PPE usage for each OES which strongly influences the risk conclusions. Important assumptions and key sources of uncertainty in the risk characterization are described in more detail in Section 4.3.2.

EPA's assessments, risk estimations, and risk determinations account for uncertainties throughout the risk evaluation. EPA used reasonably available information, in a fit-for-purpose approach, to develop a risk evaluation that relies on the best available science and is based on the weight of the scientific evidence. For instance, systematic review was conducted to identify reasonably available information related to HBCD hazards and exposures. If no applicable monitoring data were identified, exposure scenarios were assessed using a modeling approach that requires the input of various chemical parameters and exposure factors. When possible, default model input parameters were modified based on chemical-specific inputs available in literature databases. The consideration of uncertainties supports the Agency's risk determinations, each of which is supported by substantial evidence, as set forth in detail in later sections of this final Risk Evaluation.

Potentially Exposed Susceptible Subpopulations

TSCA Section 6(b)(4) requires that EPA conduct Risk Evaluations to determine whether a chemical substance presents unreasonable risk under the conditions of use, including unreasonable risk to a potentially exposed or susceptible subpopulation identified as relevant to the Risk Evaluation. TSCA Section 3(12) defines "*potentially exposed or susceptible subpopulation as a group of individuals within the general population identified by the Administrator who, due to either greater susceptibility or greater exposure, may be at greater risk than the general population of adverse health effects from exposure to a chemical substance or mixture, such as infants, children, pregnant women, workers, or the elderly.*"

In developing the Risk Evaluation, EPA analyzed reasonably available information to ascertain whether some human receptor groups may have greater exposure than the general population to the hazard posed by HBCD. In consideration of the most highly exposed groups, EPA considered workers using HBCD and ONUs in the vicinity of HBCD to be PESS groups based on higher exposures than the general population. Exposures of HBCD would also be expected to be higher amongst individuals exposed to scenario-specific exposures, from releases to water, air, and consumer articles as compared to the general population. These include the highly exposed general population, or individuals who are expected to live close to facility sources (Section 2.4.3).

Based on the bioaccumulation of HBCD and partitioning to lipid, subpopulations with elevated body fat or on a high-fat diet are of increased susceptibility and represent an important PESS group. Pregnant women and women of reproductive age are another potentially exposed or susceptible subpopulation based on the possibility of reproductive and developmental effects following exposure. Humans with pre-existing health conditions or genetic predispositions related to any of the affected health domains are also susceptible subpopulations, as they may experience HBCD toxicity at lower doses than the general population.

EPA accounted for PESS in risk estimation by providing risk conclusions (Section 4.5.2) based on the most sensitive receptor or lifestage (*i.e.*, female workers of reproductive age for occupational risk, the youngest relevant lifestage for general population and consumer risk) and consideration of high end exposures (Table 4-27;

Table 4-28). Estimated risks to additional highly-exposed PESS groups were also separately calculated (Table 4-29).

Aggregate and Sentinel Exposures

Section 6(b)(4)(F)(ii) of TSCA requires the EPA, as a part of the Risk Evaluation, to describe whether aggregate or sentinel exposures under the conditions of use were considered and the basis for their consideration. The EPA has defined aggregate exposure as “*the combined exposures to an individual from a single chemical substance across multiple routes and across multiple pathways* (40 CFR Section 702.33).” Exposures to HBCD were evaluated by inhalation and dermal routes separately for workers and consumers. Inhalation and dermal exposures are assumed to occur simultaneously for workers and consumers. EPA chose not to employ simple additivity of exposure pathways at this time within a COU because of the uncertainties present in the current exposure estimation procedures that may lead to an overestimate of exposure without the use of a PBPK model available for determining the effect on internal dose estimates. For all general population exposure routes, background aggregate exposures for all exposure routes were combined with specific modeled exposures for the pathway of interest (*i.e.*, fish ingestion, air inhalation, dust/indoor air, mouthing). Aggregating general population exposures is appropriate because these background exposures are based on monitoring data and account for the persistence of HBCD in biological tissues.

The EPA defines sentinel exposure as “*the exposure to a single chemical substance that represents the plausible upper bound of exposure relative to all other exposures within a broad category of similar or related exposures*” (40 CFR Section 702.33). In this Risk Evaluation, the EPA considered sentinel exposure the highest exposure given the details of the conditions of use and the potential exposure scenarios. EPA characterized high-end exposures in evaluating both modeled and monitored exposures to various receptors. Sentinel exposures for workers are the high-end exposure levels with assumptions of no PPE within each OES. In cases where sentinel exposures result in MOEs greater than the benchmark, indicating that risk is not likely, EPA did no further analysis to refine the risk estimates because sentinel exposures represent the worst-case scenario.

For additional discussion on incorporation of aggregate and sentinel exposures into the Risk Evaluation, see Section 4.4.2.

Unreasonable Risk Determination

In each Risk Evaluation under TSCA Section 6(b), EPA determines whether a chemical substance presents an unreasonable risk of injury to health or the environment, under the conditions of use. The determination does not consider costs or other non-risk factors. In making this determination, EPA considers relevant risk-related factors, including, but not limited to: the effects of the chemical substance on health and human exposure to such substance under the conditions of use (including cancer and non-cancer risks); the effects of the chemical substance on the environment and environmental exposure under the conditions of use; the population exposed (including any potentially exposed or susceptible subpopulations, as determined by EPA); the severity of hazard (including the nature of the hazard, the irreversibility of the hazard); and uncertainties. EPA also takes into consideration the Agency’s confidence in the data used in the risk estimate. This includes an evaluation of the strengths, limitations, and uncertainties associated with the information used to inform the risk estimate and the risk characterization. The rationale for the unreasonable risk determination is in Section 5.2. The Agency’s determinations are supported by substantial evidence, as set forth in detail in later sections of this final Risk Evaluation. EPA did not exclude any activity determined to be a COU, and a risk determination was made on all identified COUs.

Unreasonable Risk of Injury to the Environment

Listed below are EPA's determinations of unreasonable risk for specific conditions of use of HBCD based on risks of exposure for aquatic and terrestrial organisms. To characterize the exposures to HBCD by aquatic and terrestrial organisms, EPA considered modeled data to represent surface water and sediment concentrations near facilities actively releasing HBCD to surface water, and soil concentrations due to facilities actively releasing HBCD through air releases and deposition. Monitored concentrations to represent ambient water, sediment and soil concentrations of HBCD were also considered to characterize exposure of aquatic and terrestrial organisms to HBCD. EPA considered the biological relevance of the species to determine the environmental hazard thresholds, as well as frequency and duration of the exposures, and uncertainties given the different sources of information used to characterize the hazard and exposure and derive risk quotients (RQ). For pelagic organisms, EPA evaluated unreasonable risk of delayed hatching and reduced growth of juvenile organisms due to acute and chronic exposures to HBCD, respectively. EPA evaluated algae risk separately from the categorization of an acute or chronic exposure, and unreasonable risk of reduced algae growth was evaluated. Based on the physical-chemical properties, HBCD partitions to sediment and soil. For benthic organisms, EPA evaluated unreasonable risk of reduced reproduction due to chronic exposure to HBCD. EPA also evaluated unreasonable risks of reduced reproduction and survival of soil organisms due to chronic exposure to HBCD. EPA determined that the evaluation supports an unreasonable risk determination to aquatic organisms (pelagic and benthic) for each condition of use of HBCD within the scope of the Risk Evaluation but does not support unreasonable risk determinations for terrestrial soil organisms.

Unreasonable Risk of Injury to Aquatic Organisms: EPA made unreasonable risk determinations for risks to pelagic and benthic species due to HBCD exposures at high-end concentrations in both surface water and sediment. The unreasonable risk determination applies to six of twelve conditions of use within the scope of the Risk Evaluation.

No Unreasonable Risk of Injury to Terrestrial Organisms: The hazard endpoints for terrestrial organisms in the Risk Evaluation are growth, reproduction, and thyroid hormone effects. Results of the evaluation support a determination of no unreasonable risk to terrestrial organisms for all conditions of use of HBCD within the scope of the Risk Evaluation.

No Unreasonable Risk of Injury to Health: EPA's determinations of unreasonable risk for specific conditions of use of HBCD listed below are based on health risks of exposure to HBCD for workers, the general population, the highly exposed general population (fish consumption, air inhalation, and worst-case aggregate infant (less than 1 year old) exposure), consumers, and other PESS. The hazard endpoint for acute exposures is offspring loss and for chronic exposures, the endpoint is non-cancer thyroid effects. Risks for cancer were not evaluated based on inadequate weight of scientific evidence for cancer hazard (Section 3.2.4.2).

No Unreasonable Risk of Injury to Health of the General Population: As part of the problem formulation for HBCD, EPA found that exposures to the general population may occur from the conditions of use due to releases to air, water or land, and evaluated the risk of HBCD exposures to the general population from multiple routes. EPA found no unreasonable risk for the general population or the highly exposed general population from any of the conditions of use via exposures from ambient air, surface water, biosolids, or sediments. Similarly, EPA determined that the evaluation does not support an unreasonable risk determination to the general population of exposure to HBCD via drinking water based on a

qualitative assessment of the physical chemical properties and fate of HBCD in the environment as well as the absence of any detection of HBCD in monitored water samples.

In addition, EPA found that exposures to general population via disposal pathways fall under the jurisdiction of other environmental statutes administered by EPA, *i.e.*, SDWA (Safe Drinking Water Act). As explained in more detail in Section 1.4.2, EPA believes it is both reasonable and prudent to tailor TSCA risk evaluations when other EPA offices have expertise and experience to address specific environmental media, rather than attempt to evaluate and regulate potential exposures and risks from those media under TSCA. EPA believes that coordinated action on exposure pathways and risks addressed by other EPA-administered statutes and regulatory programs is consistent with statutory text and legislative history, particularly as they pertain to TSCA's function as a "gap-filling" statute, and also furthers EPA aims to efficiently use Agency resources, avoid duplicating efforts taken pursuant to other Agency programs, and meet the statutory deadline for completing risk evaluations. EPA has therefore tailored the scope of the risk evaluation for HBCD using authorities in TSCA Section 6(b) and 9(b)(1).

Unreasonable Risk of Injury to Health of Workers: The Risk Evaluation of non-cancer effects from acute and chronic dermal and inhalation occupational exposures was the basis for EPA's determination of no unreasonable risk to workers' health for eight conditions of use within the scope of the Risk Evaluation. For two other COUs within the scope of the Risk Evaluation (Commercial/Consumer Use of Building Materials (Installation) and Disposal (Demolition)), EPA determined there is unreasonable risk to workers from inhalation exposure.

EPA generally assumes compliance with OSHA requirements for protection of workers, including the implementation of the hierarchy of controls. In support of this assumption, EPA used reasonably available information, including public comments, indicating that some employers, particularly in the industrial setting, are providing appropriate engineering or administrative controls or PPE to their employees consistent with OSHA requirements. EPA does not have reasonably available information to support this assumption for each COU; however, EPA does not believe that the Agency must presume, in the absence of such information, a lack of compliance with existing regulatory programs and practices. Rather, EPA assumes there is compliance with worker protection standards unless case-specific facts indicate otherwise, and therefore existing OSHA regulations for worker protection and hazard communication will result in use of appropriate PPE in a manner that achieves the stated APF or PF. EPA's decisions for unreasonable risk to workers are based on high-end exposure estimates, in order to account for the uncertainties related to whether or not workers are using PPE. EPA believes this is a reasonable and appropriate approach that accounts for reasonably available information and professional judgment related to worker protection practices, and addresses uncertainties regarding availability and use of PPE.

For each COU of HBCD with an identified risk for workers, EPA assumes, as a baseline, the use of a respirator with an APF of 5, 10, or 50. Similarly, EPA assumes the proper use of impervious gloves, which is expected to completely prevent dermal exposures to HBCD. However, EPA assumes that for some conditions of use, the use of appropriate respirators is not a standard industry practice, based on best professional judgment given the burden associated with the use of supplied-air respirators, including the expense of the equipment and the necessity of fit-testing and training for proper use. EPA does not assume that as a standard industry practice that workers installing or demolishing XPS/EPS insulation in buildings and structures wear respirators.

The unreasonable risk determinations incorporate consideration of the PPE that EPA assumes that

workers use. A full description of EPA’s unreasonable risk determination for each condition of use is in Section 5.2.

Unreasonable Risk of Injury to Health of Occupational Non-Users (ONUs): EPA expects that ONUs have lower exposure levels than workers in most instances (Section 4) but exposures could not be quantified, and EPA did not make unreasonable risk determinations for ONUs in most cases. For the two conditions of use encompassing installation or demolition of building insulation for which EPA expects that worker and ONU exposure are similar, EPA found unreasonable risk from these exposures to HBCD.

No Unreasonable Risk of Injury to Health of Consumers: EPA evaluated non-cancer risks to consumers from acute and chronic inhalation and ingestion exposures to indoor air and dust. These exposures were associated with consumer use of products and articles in buildings and vehicles. In addition, EPA assessed the risk to children from mouthing of articles made from recycled plastic containing HBCD. EPA did not find unreasonable risk from this consumer exposure to HBCD.

Unreasonable Risk of Injury to Health of Potentially Exposed or Susceptible Subpopulations Not Associated with Any Particular COU: Based on risk estimates of exposure to HBCD for various PESS including subsistence fishers and newborns less than 1 year old, EPA did not find unreasonable risk of exposure to HBCD.

Summary of Unreasonable Risk Determinations:

In conducting Risk Evaluations, “EPA will determine whether the chemical substance presents an unreasonable risk of injury to health or the environment under each COU within the scope of the Risk Evaluation...” 40 CFR 702.47. Pursuant to TSCA Section 6(i)(1), a determination of “no unreasonable risk” shall be issued by order and considered to be a final agency action. Under EPA’s implementing regulations, “[a] determination by EPA that the chemical substance, under one or more of the conditions of use within the scope of the risk evaluation, does not present an unreasonable risk of injury to health or the environment will be issued by order and considered to be a final Agency action, effective on the date of issuance of the order.” 40 CFR 702.49(d).

EPA evaluated 12 conditions of use. EPA has determined that the following conditions of use of HBCD do not present an unreasonable risk of injury to health or the environment. These determinations are considered final agency action and is being issued by order pursuant to TSCA Section 6(i)(1). The details of these determination are in Section 5.2 and the TSCA Section 6(i)(1) order is contained in Section 5.4.1 of this final Risk Evaluation.

Conditions of Use that Do Not Present an Unreasonable Risk
<ul style="list-style-type: none"> • Processing: Recycling (of electronics waste containing high impact polystyrene (HIPS) that contains HBCD) • Distribution • Commercial/Consumer Use: Other – Replacement Automobile Parts • Commercial/Consumer Use: Other – Plastic and Other Articles • Commercial/Consumer Use: Other – Formulated Products and Articles • Disposal of Formulated Products and Articles

EPA has determined that the following conditions of use of HBCD present an unreasonable risk of injury to health and/or the environment. There is unreasonable risk of injury to the environment for the six conditions of use below as well as unreasonable risk of injury to the health of workers for commercial/consumer use of building/construction materials and for disposal (demolition). EPA will initiate TSCA Section 6(a) risk management actions on these conditions of use as required under TSCA Section 6(c)(1). Pursuant to TSCA Section 6(i)(2), the unreasonable risk determinations for these conditions of use are not considered final agency action. The details of these determinations are in Section 5.2.

Manufacturing That Presents an Unreasonable Risk to the Environment
--

- | |
|--|
| <ul style="list-style-type: none"> • Import |
|--|

Processing that Presents an Unreasonable Risk to the Environment

- | |
|---|
| <ul style="list-style-type: none"> • Processing: Incorporation into a Formulation, Mixture, or Reaction Products • Processing: Incorporation into Article • Processing: Recycling (of XPS and EPS foam, resin, and panels containing HBCD) |
|---|

Commercial/Consumer* Use that Presents an Unreasonable Risk to Human Health and the Environment
--

- | |
|---|
| <ul style="list-style-type: none"> • Commercial/Consumer Use: Building/Construction Materials (Installation) |
|---|

<p>*Note: While commercial and consumer use was assessed as part of the same exposure scenario, risks were quantified separately and no unreasonable risks to consumers were identified.</p>
--

Disposal that Presents an Unreasonable Risk to Human Health and the Environment
--

- | |
|---|
| <ul style="list-style-type: none"> • Disposal (Demolition) |
|---|

1 INTRODUCTION

This document is the final Risk Evaluation for HBCD under the Frank R. Lautenberg Chemical Safety for the 21st Century Act. The Frank R. Lautenberg Chemical Safety for the 21st Century Act amended the Toxic Substances Control Act (TSCA), the nation's primary chemicals management law, on June 22, 2016.

The Agency published the *Scope of the Risk Evaluation for HBCD* ([U.S. EPA 2017d](#)) in June 2017, and the *Problem Formulation for Cyclic Aliphatic Bromide Cluster (HBCD)* in June 2018 ([U.S. EPA 2018g](#)), which represented the analytical phase of Risk Evaluation in which “the purpose for the assessment is articulated, the problem is defined, and a plan for analyzing and characterizing risk is determined” as described in Section 2.2 of the *Framework for Human Health Risk Assessment to Inform Decision Making*. EPA received comments on the published Problem Formulation ([U.S. EPA 2018g](#)) for HBCD and has considered the comments specific to HBCD, as well as more general comments regarding EPA's chemical Risk Evaluation approach for developing the Risk Evaluations for the first 10 chemicals EPA is evaluating.

The problem formulation identified the conditions of use and presented a conceptual model and an analysis plan. Based on EPA's analysis of the conditions of use, physical-chemical and fate properties, environmental releases, and exposure pathways, the problem formulation preliminarily concluded that further analysis was necessary for exposure pathways to environmental receptors, workers, consumers and the general population. The mouthing of articles pathway was added to the conceptual model after the published Problem Formulation based on review of reasonably available information. Further analysis was not conducted for the drinking water pathway based on a qualitative assessment of the physical chemical properties and fate of HBCD in the environment. EPA subsequently published a draft Risk Evaluation for HBCD and has taken public and peer review comments.

At the beginning of the Risk Evaluation process for HBCD, EPA had information that a small percentage of the chemical's production volume was used in the processing of several products and articles, including electronics (Use Document, [EPA-HQ-OPPT-2016-0735-0003](#)). Further investigation led EPA to conclude that HBCD was no longer manufactured, processed, or distributed for use in such products and articles. The uses of HBCD in such products and articles and the disposal of those products and articles were therefore excluded from the evaluation as “legacy uses” and “associated disposal,” respectively. In August 2019, EPA completed its draft Risk Evaluation on the narrowed scope, and later that year, the court made its ruling in *Safer Chemicals Healthy Families v. U.S. Env'tl. Prot.* Because of the court ruling, as well as public and SACC review comments, EPA conducted additional assessments on what would have been termed “legacy use”: general population exposure to HBCD in dust and indoor air released from HBCD-containing products and articles that are still in use but for which the manufacture, processing, and distribution for such use has ceased.

The conclusions, findings, and determinations in this final Risk Evaluation are for the purpose of identifying whether the chemical substance presents unreasonable risk or no unreasonable risk under the conditions of use, in accordance with TSCA Section 6, and are not intended to represent any findings under TSCA Section 7.

As per EPA's final rule, [Procedures for Chemical Risk Evaluation Under the Amended Toxic Substances Control Act](#) (82 FR 33726 (July 20, 2017)), this Risk Evaluation was subject to both public

comment and peer review, which are distinct but related processes. EPA provided 60 days for public comment on any and all aspects of this Risk Evaluation, including the submission of any additional information that might be relevant to the science underlying the Risk Evaluation and the outcome of the systematic review associated with HBCD. This satisfies TSCA Section 6(b)(4)(H), which requires EPA to provide public notice and an opportunity for comment on a draft Risk Evaluation prior to publishing a final Risk Evaluation.

Peer review was conducted in accordance with EPA's regulatory procedures for chemical Risk Evaluations, including using the [EPA Peer Review Handbook](#) and other methods consistent with the science standards laid out in Section 26 of TSCA (*See* 40 CFR 702.45). As explained in the [Risk Evaluation Rule](#) (82 FR 33726 (July 20, 2017)), the purpose of peer review is for the independent review of the science underlying the risk assessment. Peer review will therefore address aspects of the underlying science as outlined in the charge to the peer review panel such as hazard assessment, assessment of dose-response, exposure assessment, and risk characterization.

As EPA explained in the [Risk Evaluation Rule](#) (82 FR 33726 (July 20, 2017)), it is important for peer reviewers to consider how the underlying risk evaluation analyses fit together to produce an integrated risk characterization, which forms the basis of an unreasonable risk determination. EPA believed peer reviewers were most effective in this role if they received the benefit of public comments on draft risk evaluations prior to peer review. For this reason, and consistent with standard Agency practice, the public comment period preceded peer review. The final risk evaluation changed in response to public comments received on the draft risk evaluation and/or in response to peer review, which itself may be informed by public comments. EPA responded to public and peer review comments received on the draft risk evaluation and explained changes made in response to those comments in this final risk evaluation and the associated response to comments document.

In this final Risk Evaluation, Section 1 presents the basic physical-chemical characteristics of HBCD, as well as a background on regulatory history, conditions of use, and conceptual models, with particular emphasis on any changes since the publication of the [draft Risk Evaluation](#). Section 1 also includes a discussion of the systematic review process utilized in this final Risk Evaluation. Section 2 provides a discussion and analysis of the exposures, both human and environmental, that can be expected based on the conditions of use for HBCD. Section 3 discusses environmental and human health hazards of HBCD. Risk characterization is presented in Section 4, which integrates and assesses the best available science and “reasonably available information”⁴ on environmental and human health hazards and exposures, as required by TSCA (15 U.S.C. 2605(b)(4)(F)). This section also includes a discussion of any uncertainties and how they impact the Risk Evaluation. In Section 0, the Agency presents the risk determination of whether risks posed by the chemical substance under the conditions of use are “unreasonable” as required under TSCA (15 U.S.C. 2605(b)(4)).

EPA also solicited input on the first 10 chemicals as it developed use documents, scope documents, and problem formulations. At each step, EPA has received information and comments specific to individual chemicals and of a more general nature relating to various aspects of the Risk Evaluation process, technical issues, and the regulatory and statutory requirements. EPA has considered comments and

⁴ “Reasonably available information means information that EPA possesses or can reasonably generate, obtain, and synthesize for use in risk evaluations, considering the deadlines specified in TSCA Section 6(b)(4)(G) for completing such evaluation. Information that meets the terms of the preceding sentence is reasonably available information whether or not the information is confidential business information, that is protected from public disclosure under TSCA Section 14.”

information received at each step in the process and factored in the information and comments as the Agency deemed appropriate and relevant including comments on the published problem formulation of HBCD.

1.1 Physical and Chemical Properties

Physical and chemical properties influence the environmental behavior and the toxic properties of a chemical, thereby informing the potential conditions of use, exposure pathways and routes and hazards that EPA intends to consider. For scope development, EPA considered the measured or estimated physical and chemical properties set forth in Table 1-1. EPA found no additional information throughout the development of the Risk Evaluation that would change these values. Data evaluation results for physical and chemical properties studies can be found in [*Risk Evaluation for Cyclic Aliphatic Bromide Cluster (HBCD) Systematic Review Supplemental File: Data Quality Evaluation of Physical-Chemical Properties Studies* ([U.S. EPA 2019t](#))].

HBCD is a white odorless non-volatile solid that is used as a flame retardant. Technical HBCD is often characterized as a mixture of mainly three diastereomers, α -, β - and γ -HBCD with the γ -HBCD as main component (>70%). The fate and biological effects of these compounds are stereoselective, and there is limited data for the diastereomers. Technical HBCD may contain some impurities, such as tetrabromocyclododecene or other isomeric HBCDs ([UNEP 2010a](#)), which are not included in this Risk Evaluation. The density of HBCD is greater than that of water (2.24 g/cm³ at 20°C). It has low water solubility (66 µg/L at 20°C) and a log octanol:water partition coefficient (log K_{ow}) of 5.62.

Table 1-1. Physical and Chemical Properties of HBCD

Property	Value ^a	References
Molecular formula	C ₁₂ H ₁₈ Br ₆	
Molecular weight	641.7 g/mole	
Physical form	White solid; odorless	(EINECS 2008)
Melting point	Ranges from approximately: 172-184°C to 201-205°C	(EINECS 2008) citing (Smith et al. 2005)
Boiling point	>190°C (decomposes)	(Peled et al. 1995)
Density	2.24 g/cm ³	(EINECS 2008)
Vapor pressure	4.7E-07 mmHg at 21°C	(Wildlife Intl 1997c)
Vapor density	Not readily available	(EINECS 2008)
Water solubility	66 µg/L at 20°C	(EINECS 2008) citing (MacGregor and Nixon 2004)
Octanol:water partition coefficient (log K _{ow})	5.625 at 25°C	(Wildlife Intl 1997a)
Henry's Law constant	7.4E-06 atm-m ³ /mole (calculated)	(U.S. EPA 2012b)
Flash point	Not readily available	
Autoflammability	Decomposes at >190°C	(EINECS 2008)
Viscosity	Not readily available	
Refractive index	Not readily available	
Dielectric constant	Not readily available	
^a Measured unless otherwise noted.		

1.2 Uses and Production Volume

1.2.1 Data and Information Sources

The summary of use and production volume information for HBCD presented below is based on research conducted for the *Problem Formulation Document for Cyclic Aliphatic Bromide Cluster (HBCD)* and any additional information that was obtained since the publication of that document. This research was based on reasonably available information, including the *Use and Market Profile for HBCD*, ([EPA-HQ-OPPT-2016-0735-0049](#)), public meetings, and meetings with companies, industry groups, chemical users and other stakeholders to aid in identifying and verifying the conditions of use (COUs) included in this final Risk Evaluation. The information and input received from the public, stakeholder meetings and the additional contacts were incorporated into this section, as applicable.

1.2.2 Domestic Manufacture of HBCD

Domestic manufacture of HBCD ceased as of 2017 and is not intended, known, or reasonably foreseen to occur, and is therefore not considered a COU in this final Risk Evaluation.

As shown in Table 1-2, data reported for the CDR period for 2016 for HBCD indicate that between 1 and 10 million pounds of each CASRN were manufactured in or imported into the United States in 2015; the national production volume is CBI (U.S. EPA 2016d). These are the most recent CDR data available. The data provides an overview of the historic trends in production volume of HBCD. For both CASRNs, site-specific production volumes for the 2015 reporting year were withheld as TSCA CBI. Six firms comprising nine sites are identified by the 2016 CDR as manufacturers or importers of HBCD: Chemtura Corporation, Albemarle Corporation, Dow Chemical Company, Campine NV, BASF Corporation, and Styropek USA, Inc (U.S. EPA 2016d). ICL-IP previously manufactured an HBCD-containing flame retardant marketed as FR-1206. This product has been discontinued, and ICL-IP has reportedly ceased production of products containing HBCD (Anon, 2015). The 2016 CDR reporting data for HBCD from EPA's CDR database (U.S. EPA 2016d) are provided in Table 1-2. CDR data collection occurs every four years (next reporting period will be in 2020); this information has not changed from that provided in the 2018 HBCD Problem Formulation.

Table 1-2. Production Volume (Manufacture and Import) of HBCD in CDR Reporting Period (2012 to 2015)^a

Reporting Year		2012	2013	2014	2015
Total Aggregate Production Volume (lbs)	CASRN 25637-99-4	1-10 million	1-10 million	1-10 million	1-10 million
	CASRN 3194-55-6	10-50 million	10-50 million	1-10 million	1-10 million
^a The CDR data for the 2016 reporting period is available via ChemView (https://java.epa.gov/chemview) (U.S. EPA 2016d).					

U.S. manufacturers have indicated complete replacement of HBCD in their product lines (U.S. EPA 2017j) and that depletion of stockpiles and cessation of export was completed in 2017 based on communications with recent manufacturers. According to the North American Flame Retardant Alliance (NAFRA), "HBCD is no longer domestically manufactured or imported and NAFRA members have worked with downstream users to transition to newer technologies that have an improved environmental, health, and safety profile while also providing critical fire safety benefits" (ACC/North American Flame Retardant Alliance, 2019).

Communication with Chemtura (now called Lanxess Solutions, US) indicates that the company has not manufactured HBCD since 2015, and that there are currently no U.S. manufacturers of the chemical. The company does not intend to manufacture, import, or export HBCD in the future and has no existing stockpiles (LANXESS 2017). Albemarle Corporation, another historic manufacturer of HBCD, indicated that they stopped manufacturing HBCD flame retardants in 2016 and do not intend to resume the manufacture of HBCD-based flame retardants. In 2017, Albemarle exported its entire inventory of approximately 57 metric tons (MT) of HBCD to Mexico and Turkey for use in construction (XPS/EPS) applications. Albemarle does not intend to import HBCD in the future (Albemarle 2017). Dow Chemical developed the polymeric flame retardant that replaced HBCD for use in insulation boards used in construction. It is licensed to other manufacturers including Albemarle, Chemtura, and Bromine Compounds Limited (part of ICL Industrial Products); these companies sell the chemical under different trade names. Consideration of the status of manufacturing, availability of viable substitutes and the international regulatory focus on phasing out of domestic manufacturing, use and international trade in HBCD has led EPA to conclude that domestic manufacturing of HBCD is not known, intended, or reasonably foreseen to occur.

In their public comment on the draft Risk Evaluation, the North American Flame Retardants Alliance (NAFRA) of the American Chemistry Council stated that HBCD is no longer domestically manufactured or imported and NAFRA members have worked with downstream users to transition to newer technologies that have an improved environmental, health, and safety profile while also providing critical fire safety benefits. NAFRA represents the former major manufacturers and importers of HBCD and the possibility remains that small businesses are importing the chemical.

Table 1-3 below presents the various conditions under which a company must report to CDR (“x” indicates reporting required) for the 2016 reporting period. Typically, a manufacturer is required to report any volume above 25,000 pounds, while small manufacturers⁵ are only required to report any volume above 100,000 pounds. Since HBCD is subject to a TSCA Section 5(a)(2) Significant New Use Rule (SNUR), the reporting threshold has been reduced to 2,500 pounds for large size firms. For small manufacturers, however, the threshold remains at 100,000 pounds. EPA has no indication that small manufacturers are manufacturing HBCD and concludes that manufacturing of HBCD is not reasonably foreseen and therefore is excluded as a Condition of Use in this final Risk Evaluation.

Table 1-3. Conditions under Which a Company Must Report to CDR (shaded area applies to HBCD reporting specifically and “x” indicates broad conditions requiring reporting)

TSCA Action	Obligation to Report to CDR Information When Subject to TSCA Action as Indicated in Left column			
	Subject to 25,000 lb. reporting threshold	Subject to 2,500 lb reporting threshold	Not eligible for certain full or partial exemptions from reporting	Not eligible for small manufacturer exemption
Not subject to TSCA action	X			
TSCA section 4 rules (proposed or promulgated)	X		X	X
Enforceable Consent Agreements (ECAs)	X		X	
TSCA section 5(a)(2) SNURs (proposed or promulgated)		X	X	
TSCA section 5(b)(4) rules (proposed or promulgated)		X	X	X
TSCA section 5(e) orders		X	X	X
TSCA section 5(f) orders		X	X	
TSCA section 5 civil actions		X	X	X
TSCA section 6 rules (proposed or promulgated)		X	X	X
TSCA section 7 civil actions		X	X	X

⁵ The definition of a small manufacturer varies depending on the sector.

1.2.3 Importation of HBCD

In 2011, the total global production of HBCD was estimated at approximately 31,000 metric tons in 2011, of which about 13,000 tons were produced in EU countries and in the United States, and 18,000 tons in China ([UNEP 2011](#)). This volume is expected to have decreased following the agreement by parties to the United Nations Stockholm Convention on Persistent Organic Pollutants (POPs), in May 2013. Parties to the Convention will develop inventories of HCBd in the future ([UNEP 2011](#)).

The companies that previously reported HBCD import volumes to CDR have stated to EPA that they permanently stopped their import activity in 2016 or 2017. The Dow Chemical Company imported 19 metric tons (MT) of HBCD in 2016 and roughly 48 MT in 2017. Dow possessed roughly 41 MT of HBCD in stockpiles as of September 2017, which the company then used to produce XPS foam. By November 2017, Dow had stopped using HBCD at all of its plants and had no intention of importing HBCD in the future ([Dow Chemical 2017](#)). As noted above, Dow developed the polymeric flame retardant called BlueEdge for use in construction insulation boards that replaced HBCD. It is licensed to other manufacturers including Albemarle, Chemtura, and Bromine Compounds Limited (part of ICL Industrial Products); these companies sell the chemical under different trade names.

Similarly, Campine NV indicated in a correspondence with EPA that they had ceased importation of HBCD in 2016 ([Campine 2017](#)). BASF has indicated in a correspondence with EPA ([BASF 2017](#)) that the company ceased importing HBCD in 2016 and has no remaining stockpiles of the chemical. Styropek, another historic importer of HBCD based on CDR, has also indicated in its correspondences with EPA that the company phased out the use of HBCD as a flame retardant in 2016.

Datamyne (<http://www.datamyne.com>) collects import data on shipments into the United States and provides information on each shipment. Datamyne is a commercial searchable trade database that covers the import and export data and global commerce of more than 50 countries across 5 continents (approximately 76% of the world's import trade by value) and includes the cross-border commerce of the United States with over 230 trading partners. EPA queried the database for bills of lading related to HBCD. Due to the nature of Datamyne data, some shipments containing the chemical of concern may be excluded due to being categorized under other names that were not included in the search terms. Datamyne does not include articles/products containing the chemical unless the chemical name is included in the description of the article/product. Datamyne indicates that there was import of HBCD in 2016 and 2017, however, shows no import in 2018 to July 2020 when the last search was conducted for this assessment as shown in Table 1-4. .

Table 1-4. U.S. Volume of Imports of HBCD, 2016 through July 2020

Year	Total Import Volume (kgs)	Number of Unique Consignees
2016	399,315	5 ^a
2017	46,096	1
2018-2020 (July)	0	0

^a One consignee did not declare their name.
Source(s): <http://www.datamyne.com>

Although there are a number of possible source countries for importation of HBCD to the United States, under the United Nations Stockholm Convention on Persistent Organic Pollutants (POPs), 171 of the 188 Parties (countries) have agreed to ban the production, use, import, and export of HBCD, consistent with the obligations of that Convention ([SCCH 2018a, b](#)). The Convention does include a process by

which a party can apply for a time limited exemption to continue production and/or use of a listed chemical, however, that exemption is limited to the specific use(s) identified in the Convention. In accordance with Article 4, specific exemptions expire five years after the date of entry into force of the Convention with respect to that particular chemical, unless an additional five-year extension is granted by the Conference of the Parties ([SCCH 2018b](#)). For HBCD, the specific uses for which a Party can register a production or use exemption is limited to use “in EPS and XPS in buildings.” According to the *Register of Specific Exemptions* for the Convention when accessed in 2018, there were three Parties registered for production for those uses and six Parties registered for use. In July 2020, two exemptions remained in effect. The United States and approximately six other countries are not Parties to the Convention ([SCCH 2018c](#)).

EPA has no direct evidence of current import of HBCD, however, there are several countries that have not agreed to the Stockholm Convention HBCD ban or are not Parties to the Convention and therefore can still export HBCD legally to the United States. Domestic firms could import quantities of up to 100,000 lbs of HBCD per year without reporting to the CDR. Given these facts, EPA is considering the import of HBCD to be known and/or reasonably foreseen and is including it as a COU in this final Risk Evaluation.

1.2.4 Toxics Release Inventory Data on HBCD

Following the publication of the Problem Formulation in 2018, information became available for HBCD as reported by facilities to the Toxics Release Inventory (TRI) program. Under the Emergency Planning and Community Right-to-Know Act (EPCRA) Section 313, HBCD is a TRI-reportable category⁶ effective January 1, 2017 and EPA has finalized the addition of the HBCD category to the list of chemicals with special concern (see 40 CFR 372.28(a)(2)) and established a 100 lb reporting threshold. Four facilities reported HBCD for the 2017 TRI reporting year; follow-up with the companies indicates that only one facility is involved in ongoing processing of HBCD. Two facilities belong to Dow Chemical, which said it stopped producing HBCD by 2018 ([U.S. EPA, 2017c](#)). A third facility, owned by Flame Control Coatings, said in 2018 that it had stopped using HBCD for manufacture of coatings ([Flame Control Coatings, 2018](#)). The fourth facility, Indium Corporation of America, continues to process HBCD for use in the manufacture of solder paste (see more about this use in Section 1.2.5.3).

Table 1-5 provides production-related waste management data for HBCD reported by subject facilities to the TRI program for reporting years 2017 and 2018⁷. In reporting year 2017, four facilities reported a total of approximately 724 lbs of HBCD waste managed. Of this total, zero lbs were recycled, 51 lbs were recovered for energy, 82 lbs were treated, and 591 lbs were disposed of or otherwise released into the environment. In reporting year 2018, only one facility (Indium Corporation of America) reported to the TRI program for HBCD.

⁶ The HBCD category covers HBCD as identified through two primary Chemical Abstracts Service Registry Numbers (CASRN): 3194-55-6 (1,2,5,6,9,10-hexabromocyclododecane) and 25637-99-4 (hexabromocyclododecane).

⁷ Reporting year 2017 was the first year available for HBCD and reporting year 2018 is the most recent TRI data year. Data presented in Table 1-5 and Table 1-6 were queried using TRI Explorer and uses the 2018 National Analysis data set (released to the public in November 2019).

Table 1-5. Summary of HBCD TRI Production-Related Waste Managed from 2017-2018 (lbs)

Year	Number of Facilities	Recycling	Energy Recovery	Treatment	Releases ^{a,b,c}	Total Production Related Waste
2017	4 ^d	0	51	82	591	724
2018	1	0	0	0	3.6	3.6

Data source: 2017-2018 TRI Data (Updated November 2019) ([U.S. EPA 2017h](#)).

^a Terminology used in these columns may not match the more detailed data element names used in the TRI public data and analysis access points.

^b Does not include releases due to one-time events not associated with production such as remedial actions or earthquakes.

^c Counts all releases including release quantities transferred and release quantities disposed of by a receiving facility reporting to TRI.

^d Reporting facilities include: The Dow Chemical Company (2 locations), Flame Control Coatings LLC, and Indium Corporation of America.

Table 1-6 provides a summary of HBCD TRI releases to the environment for the same reporting years as Table 1-5. There were zero pounds of HBCD reported as released to water via surface water discharges, and a total of 79 lbs of air releases from collective fugitive and stack air emissions reported in 2017. The majority of HBCD was disposed of to landfills other than Resource Conservation and Recovery Act (RCRA) Subtitle C (511 lbs), and there was one pound of HBCD transferred to a waste broker for disposal. In reporting year 2018, Indium Corporation of America reported one pound of stack air emissions of HBCD and 2.6 lbs of HBCD sent off-site to a waste broker for disposal.

Table 1-6. Summary of HBCD TRI Releases to the Environment from 2017-2018 (lbs)

	Number of Facilities	Air Releases		Water Releases	Land Disposal			Other Releases ^a	Total On- and Off-Site Disposal or Other Releases ^{b, c}
		Stack Air Releases	Fugitive Air Releases		Class I Under-ground Injection	RCRA Subtitle C Landfills	All other Land Disposal ^a		
Totals 2017	4 ^e	77	2	0	0	0	511	1	591
		79 ^d			511 ^d				
Totals 2018	1	1	0	0	0	0	0	2.6	3.6
		1			0				

Data source: 2017-2018 TRI Data (Updated November 2019) ([U.S. EPA 2017h](#)).

^a Terminology used in these columns may not match the more detailed data element names used in the TRI public data and analysis access points.

^b These release quantities do include releases due to one-time events not associated with production such as remedial actions or earthquakes.

^c Counts release quantities once at final disposition, accounting for transfers to other TRI reporting facilities that ultimately dispose of the chemical waste.

^d Value shown may be different than the summation of individual data elements due to decimal rounding.

^e Reporting facilities include: The Dow Chemical Company (2 locations), Flame Control Coatings LLC, Indium Corporation of America.

While production-related waste managed shown in Table 1-5 excludes any quantities reported as catastrophic or one-time releases (TRI section 8 data), release quantities shown in Table 1-6 include both production-related and non-routine quantities (TRI section 5 and 6 data) from 2017-2018. As a result, release quantities may differ slightly and may further reflect differences in TRI calculation methods for reported release range estimates ([U.S. EPA 2017h](#)).

1.2.5 Uses of HBCD

Descriptions of the industrial, commercial and consumer use categories identified from the 2016 CDR ([U.S. EPA 2016d](#)) and included in the life cycle diagram are summarized in Section 1.4.1. The descriptions provide a brief overview of uses by life cycle stage in Figure 1-1. The descriptions provided below are primarily based on the corresponding industrial function category and/or commercial and consumer product category descriptions from the 2016 CDR and can be found in EPA's Instructions for Reporting 2016 TSCA Chemical Data Reporting ([U.S. EPA 2016b](#)).

1.2.5.1 Automobile Replacement Parts

EPA received a public comment from the Global Automakers Association stating that HBCD is no longer used in new automobile manufacturing and is only present in replacement parts manufactured prior to the date of the EPA HBCD Scoping Document ([EPA-HQ-OPPT-2016-0735-0027](#)). Major automobile manufacturers have phased out use of HBCD in U.S. automobile and part production but continue to use it in 155 replacement parts, according to a list provided to EPA by the Alliance of Automobile Manufacturers in November 2018 after publication of the Problem Formulation. For approximately 80% of the automobile replacement parts, the HBCD is in polystyrene headliners; most of the remaining 20% are other parts made with HBCD-containing polystyrene or other plastics. A total of five parts have HBCD in solder ([Alliance of Automobile Manufacturers, 2018](#)). A public comment by

the Alliance of Automobile Manufacturers the following year ([EPA-HQ-OPPT-2019-0237-0049](#)) stated that “data collected by Alliance members and submitted previously to EPA confirmed that HBCD is present only in automotive replacement parts and is not found in production parts used in new vehicle assembly. Our data also shows that HBCD is being phased out (or has already been phased out) of replacement parts.” EPA includes the processing and use of HBCD in automotive replacement parts in this final Risk Evaluation.

1.2.5.2 Expanded Polystyrene (EPS) and Extruded Polystyrene (XPS) Foam

Use in EPS and XPS foam had historically accounted for 95% of all HBCD applications ([U.S. EPA 2014d](#); [UNEP 2010a](#)). Based on information from market reports ([U.S. EPA 2017j](#)), HBCD was used primarily in construction materials, which may include structural insulated panels (SIPS). “Building/Construction Materials” include products containing HBCD as a flame retardant primarily in XPS and EPS foam insulation products that are used for the construction of residential, public, commercial or other structures ([UNEP 2010a](#); [Weil and Levchik 2009](#)). The building and construction industry has used EPS and XPS foam thermal insulation boards and laminates for sheathing products. HBCD is added to EPS and XPS foam in the form of a resin. EPS foam prevents freezing, provides a stable fill material and creates high-strength composites in construction applications. XPS foam board is used mainly for roofing applications and architectural molding. HBCD is used in both types of foams because it is highly effective at levels less than 1% and, therefore, maintains the insulation properties of EPS and XPS foam ([Morose 2006](#)). EPS foam boards contain approximately 0.5% HBCD by weight in the final product and XPS foam boards contain 0.5-1% HBCD by weight (Public comment, [EPA-HQ-OPPT-2016-0735-0017](#); [XPSA 2017b](#); [U.S. EPA 2014d](#); [Morose 2006](#)).

According to the EPS Industry Alliance (EPS-IA), an estimated 80-85% of EPS rigid foam insulation manufactured in the United States is molded from EPS resins supplied by EPS-IA member companies, none of whom use HBCD.

The XPS Association (XPSA) stated that its members, who are the major producers of XPS resin, supply the resin for more than 95% of the XPS foam insulation products manufactured for the North American market and that the remaining small percentage is probably made using imported resin ([XPSA 2017a](#)). This imported resin may contain HBCD, however, the extent to which EPA does not know.

Although some of the industry comments on the draft Risk Evaluation indicate more certainty than previous comments that the phaseout of HBCD is complete, the associations do not represent every possible importer and processor of HBCD. There is a potential for import of HBCD in the form of a resin for use in the manufacture of EPS and XPS foam insulation. Taking into account the high percentage of HBCD production volume dedicated to these two uses in previous years, and the fact that small quantities of HBCD could be imported at volumes below the CDR reporting threshold leaves open the possibility that EPS and XPS manufacturers that are not members of the EPS-IA and XPSA may currently be using imported HBCD resins in their processes. EPA includes the processing and use of HBCD in XPS and EPS insulation in the final Risk Evaluation.

1.2.5.3 Flux/Solder Paste

Following the publication of the HBCD Problem Formulation document ([U.S. EPA 2018g](#)), EPA learned of an ongoing use of HBCD from newly available TRI data reported by the Indium Corporation. As indicated in Table 1-5. and Table 1-6, the company submitted TRI reporting forms to the TRI program for HBCD in reporting years 2017 and 2018. In follow-on communications with EPA, Indium said it processes and uses HBCD as a fluxing aid in solder paste, which it supplies to electronics manufacturers for use on circuit boards ([Indium 2018b](#)). While the quantity of HBCD is unknown, EPA

assumes it is greater than the TRI reporting threshold of 100 lbs per year for HBCD. According to the company, the amount of HBCD used varies depending on demand from customers. The company purchased HBCD in a formulated mixture from a single supplier to manufacture flux and solder paste ([Indium 2018a](#)). The supplier (HM Royal) informed EPA that they no longer sell HBCD. Indium reported in 2017 to TRI that the maximum amount of HBCD on-site at any one point during the calendar year was between 1000 to 9,999 lbs. In 2018, the amount reported was 10,000 to 99,000 lbs.

In an email to EPA, Indium said they ship their products to their overseas facilities for the final mixing step and for sales to electronics manufacturers in China and the United States. They said the company does not sell directly to consumers, although the final consumer electronics products might be imported into the United States. Also according to the representative, Indium no longer ships the HBCD-containing products to the EU ([Indium 2018a, b](#)). Kester, another company, used HBCD in the past to manufacture solder paste, but in a phone conversation with EPA indicated that they have discontinued use ([Kester 2018](#)).

Based on the information above, EPA includes the processing of HBCD in the manufacture of solder paste in this final Risk Evaluation.

1.2.6 Recycling of EPS and XPS Foam

There is limited information about the recycling of EPS and XPS products containing HBCD. Schlummer et al. (2017) notes that EPS and XPS foam in construction insulation materials may not be frequently recycled for numerous reasons, including that insulation waste is typically not separated from mixed waste stream and most insulation containing HBCD is still in place. Schlummer et al. (2017) describe technologies available only on a small scale to separate HBCD from insulation panels and recycled polystyrene.

Reuse and recycling of EPS and XPS foam insulation board, siding, roof membrane and roofing ballast material are available in the United States for consumers. Two companies were identified that directly reuse (*e.g.*, reuse without reforming) and recycle (*e.g.*, melting and inserting into the manufacturing process) XPS and EPS foam insulation.

- Green Insulation Group: <http://www.greeninsulationgroup.com/products/>
- Nationwide Foam Recycling: <http://nationwidefoam.com/what-you-can-recycle.cfm>

Nationwide Foam Recycling, which is owned by Conigliaro Industries, Inc., indicated that their plant recycles all EPS insulation and reuses all XPS insulation ([U.S. EPA 2017j](#)). Once processed, their recycled EPS roofing insulation is taken to polystyrene product manufacturers, notably picture frame manufacturers, mostly in China. The company also delivers recycled roofing material to other local EPS recycling plants that may use different processes. Nationwide Foam Recycling processes 90,000 lbs/year of EPS standard packaging and 10,000 lbs/year of EPS roofing material and estimated only about 10-20% of EPS roofing material is recycled nationally ([U.S. EPA 2017j](#)). It is not clear what happens to the remaining volume of waste. The company also reuses XPS roofing material due the special equipment needed to recycle XPS and indicated that XPS is rarely recycled in the United States. It was estimated that the majority (>50%) of XPS roofing material is sent to landfills or waste energy plants. Processing estimates for XPS material were not provided by the company.

The recycling of HBCD-containing EPS and reuse of XPS insulations boards for use in construction materials is a COU in this final Risk evaluation. Recycling of a product containing a chemical constitutes processing of the chemical, which is a COU. HBCD was broadly used in EPS and XPS insulation boards historically, and recycled construction material would typically be required to meet

fire resistant construction codes. EPA believes that this recycling of insulation materials occurs such that the flame-retardant attributes of the insulation boards is maintained. EPA includes this recycling and the use of HBCD in the recycled boards in the scope of this final Risk Evaluation. EPA also includes consumer articles made from recycled HBCD-containing insulation boards based on experimental product-testing information on HBCD content in consumer articles, and recognition that this as an important pathway for infants and young children who may exhibit mouthing behaviors.

1.2.7 Recycling of Electronics Waste (E-Waste) Containing HIPS

While only anecdotal information is available indicating HBCD use in high impact polystyrene (HIPS) in electronics occurred in the United States (Section 2.2), there are more substantial data from the EU indicating a range of between 2 and 7 percent of HBCD production volume in Europe was historically used in HIPS and that the majority of HIPS was used in electronics ([Leisewitz et al., 2001](#); [ECHA 2008b](#)). This makes it likely that electronics products with HBCD-containing HIPS were imported into the United States in past years. EPA believes that it is reasonably foreseen that HBCD will be finding its way into recycling of electronics waste and therefore included a COU to Table 1-8: Processing – Recycling – Recycling of electronics waste containing HIPS that contain HBCD.

1.2.8 Legacy Activities and Uses

For the first 10 risk evaluation chemicals (including HBCD), EPA initially excluded chemical uses for which ongoing and prospective manufacturing, processing, and distribution had ceased; such uses were referred to as “legacy use,” a term no longer used for risk evaluations. EPA also excluded “associated disposal,” which meant “future disposal of a chemical substance that is no longer manufactured, processed, or distributed for use.” (Risk Evaluation Rule, 82 FR at 33729.) In the final risk determination, EPA did not exclude any activity determined to be a COU.

In developing the scope for HBCD, EPA learned that HBCD was no longer used to manufacture four minor-use products or articles: adhesives, coatings, HIPS in electronics, and textiles⁸ (evidence for use in HIPS in electronics was anecdotal).⁹ These so-called “legacy uses” were excluded from the scope along with related activities or disposal in later stages of the chemical life cycle, such as commercial/consumer use or disposal of HBCD-containing products and articles for which HBCD manufacture, processing, and distribution for use in such products/articles has ceased. (*Problem Formulation for Cyclic Aliphatic Bromides Cluster*, Section 1.2.7). The designation was published in the Problem Formulation (Section 2.2.2.1) and draft Risk Evaluation (Section 1.2.7). EPA received public comments stating that the HBCD risk evaluation should include “legacy use.” In 2019, the Ninth Circuit Court of Appeals ruled that EPA cannot categorically exclude “legacy use” and “associated disposal” from risk evaluations (*Safer Chemicals, Healthy Families v. U.S. Env'tl. Prot. Agency*, 943 F.3d 397, 425 (9th Cir. 2019)).

⁸ Available information indicates that only a small amount of HBCD was used for these and other minor products and articles. At least 95% of the total production volume was processed to manufacture XPS/EPS insulation. (CDR 2012). By 2018, a single company was identified as having processed HBCD in the manufacture of adhesives in the past and only one company was found that had processed HBCD for coatings manufacturing. The evidence of past processing of HBCD processed in HIPS for electronics articles was anecdotal. Use of HBCD to process consumer textiles had phased out by 2011.

⁹ The draft Risk Evaluation also erroneously included other articles as no longer being manufactured with the use of HBCD. These were children’s products (including toys and car seats) and furniture (such as bean bag chairs) (Draft Risk Evaluation Section 2.2.2.1). In fact, HBCD’s search returned no reliable information that HBCD ever was used in the processing for these articles (Problem Formulation, Section 2.2.2.1).

Due to the court ruling, EPA reconsidered the HBCD-containing products and articles to determine if additional COUs needed to be evaluated in the Risk Evaluation. The four minor-use products and articles could still be in service, for example textiles containing HBCD may be in seating in public buildings, and conveyances and electronics products or components in aircraft, office buildings, residences, or other indoor environments. Migration of the HBCD from the products and articles can expose occupants to HBCD in indoor air or dust. In addition, some items may be in the process of disposal. So although they are no longer made and sold, the HBCD in the products and articles are still conditions of use.

1.2.9 Historical Activities Resulting in Continued Exposures

In addition to the possibility of releases from use and disposal of products and articles that are no longer manufactured, processed, or distributed, exposure can occur from historical activities not associated with a current COU. This is due to HBCD's expected persistence in the environment (Section 2.1.2.5). HBCD may continue in environmental media and indoor dust long after the conclusion of a COU or a product's life cycle. Exposure from these historical releases are accounted for in the background exposure assessments performed for the environment (Section 2.3.2.1) and general population (Section 2.4.2). The measured levels of HBCD are not linked to specific sources and it is not reasonable to attempt to estimate the quantity of HBCD, if any, that originated solely from HBCD-containing products and articles which are no longer known, intended, or reasonably foreseen to occur.

1.2.10 Summary

Domestic manufacture of HBCD had ceased as of 2017 and is not intended, known, or reasonably foreseen, and is therefore not a COU in this final Risk Evaluation.

Available import data indicate that there was import of HBCD in 2016 and 2017. Under the United Nations Stockholm Convention on Persistent Organic Pollutants (POPs), 171 of the 188 Parties (countries) have agreed to ban the production, use, import, and export of HBCD; however, time-limited exemptions for certain uses exist. Given these exemptions and the possibility that small firms could import quantities of up to 100,000 lbs of HBCD per year without being required to report to the CDR. EPA includes the import of HBCD as a COU in this final Risk Evaluation.

Major automobile manufacturers have phased out use of HBCD in U.S. production of new automobiles and parts but continue to use it in 155 replacement parts, according to a list provided to EPA by the Alliance of Automobile Manufacturers. The Association was unable to confirm whether the 155 parts are domestically manufactured or imported. EPA includes the use of HBCD in automobile replacement parts in this final Risk Evaluation.

HCBD was extensively used in EPS and XPS foam insulation products used in the construction of residential, public, commercial or other structures. Based on industry association data, manufacturers in the United States are no longer using HCBD but a small percentage of EPS and XPS is probably made using imported resin that could contain HCBD. Therefore, EPA includes the use of HBCD in XPS and EPS insulation using imported HBCD in this final Risk Evaluation.

HBCD is used as a fluxing aid in solder paste, which is supplied to electronics manufacturers for use on circuit boards. Therefore, EPA includes the processing of HBCD in the manufacture of flux/solder paste in this final Risk Evaluation.

Based on current practices identified, the recycling of HBCD-containing EPS and XPS insulations boards for use in construction materials is included as a COU in this final Risk Evaluation. EPA includes

consumer articles made from recycled HBCD-containing insulation boards based on experimental product-testing information on HBCD content in consumer articles.

HIPS for electrical and electronic appliances may have been imported into the United States in past years. EPA believes that the use of HBCD in HIPS in electronics is an ongoing use and that these products may still be present in recycling facilities or may be otherwise currently being used in a manner that creates exposure potential. Recycling of HBCD containing HIPS in waste electronics is included as a COU in this final Risk Evaluation. Aggregate exposure was applied for the general population and consumers, incorporating background aggregate exposures for all exposure routes combined with specific modeled exposures for the pathway of interest.

1.2.11 List of Conditions of Use

The four COUs added for the final Risk Evaluation are shown **in bold**.

1. Manufacture – Import
2. Processing – Incorporated into formulation, mixture, or reaction product – Flame retardants used in custom compounding of resin (*e.g.*, compounding in XPS masterbatch) and in solder paste
3. Processing – Incorporation into article - Flame retardants used in plastics product manufacturing (manufacture of XPS and EPS foam; manufacture of structural insulated panels (SIPS) and automobile replacement parts from XPS and EPS foam)
4. Processing – Recycling – Recycling of XPS and EPS foam, resin, panels containing HBCD
- 5. Processing – Recycling – Recycling of electronics waste containing HIPS that contain HBCD**
6. Distribution
7. Commercial/Consumer Use – Building/construction materials – Plastic articles (hard): construction and building materials covering large surface areas (*e.g.*, XPS/EPS foam insulation in residential, public and commercial buildings, and other structures) and solder paste
8. Commercial/Consumer Use – Other – Automobile replacement parts
- 9. Commercial/Consumer Use – Other – Plastic and other articles**
- 10. Commercial/Consumer Use – Other – Formulated products and articles**
11. Disposal – Disposal-- Other land disposal (*e.g.*, Construction and demolition waste)
- 12. Disposal – Disposal-- Other land disposal (*e.g.*, Formulated products and articles)**

1.3 Regulatory and Assessment History

EPA conducted a search of existing domestic and international laws, regulations and assessments pertaining to HBCD. EPA compiled this summary from data available from federal, state, international and other government sources, as cited in Table 1-7.

Federal Laws and Regulations

HBCD is subject to federal statutes or regulations, other than TSCA, that are implemented by other offices within EPA and/or other federal agencies/departments. A summary of federal laws, regulations and implementing authorities is provided in Appendix A.1.

State Laws and Regulations

HBCD is subject to state statutes or regulations implemented by state agencies or departments. A summary of state laws, regulations and implementing authorities is provided in Appendix A.2.

Laws and Regulations in Other Countries and International Treaties or Agreements

HBCD is subject to statutes or regulations in countries other than the United States and/or international treaties and/or agreements. A summary of these laws, regulations, treaties and/or agreements is provided in Appendix A.3.

EPA has identified assessments conducted by other EPA Programs and other organizations. Depending on the source, these assessments may include information on conditions of use, hazards, exposures and potentially exposed or susceptible subpopulations. Table 1-7. shows the assessments that have been conducted.

Table 1-7. Assessment History of HBCD

Authoring Organization	Assessment
EPA assessments	
EPA, Office of Chemical Safety and Pollution Prevention (OCSPP), Office of Pollution Prevention and Toxics (OPPT)	Initial Risk Based Prioritization of High Production Volume Chemicals. Chemical/Category: Hexabromocyclododecane (HBCD) (U.S. EPA 2008a)
EPA, OCSPP, OPPT	Hexabromocyclododecane (HBCD) Action Plan (U.S. EPA 2010)
EPA, OCSPP, OPPT	Flame Retardant Alternatives for Hexabromocyclododecane (HBCD) (U.S. EPA 2014d)
EPA, OCSPP, OPPT	Toxic Chemical Work Plan Problem Formulation and Initial Assessment for HBCD, Cyclic Aliphatic Bromide Cluster (U.S. EPA 2015a)
EPA, OCSPP, OPPT	Scope of the Evaluation for Cyclic Aliphatic Bromide Cluster (HBCD) (U.S. EPA, 2017)
EPA, OCSPP, OPPT	Problem Formulation for Cyclic Aliphatic Bromide Cluster (HBCD) (U.S. EPA 2018g)
Other U.S.-based Organizations	

Authoring Organization	Assessment
Consumer Product Safety Commission (CPSC)	CPSC Staff Exposure and Risk Assessment of Flame Retardant Chemicals in Residential Upholstered Furniture (CPSC 2001)
National Research Council	National Academy of Sciences Report: Toxicological Risks of Selected Flame Retardant Chemicals (NRC 2000a)
International	
Organisation for Economic Co-operation and Development (OECD), Screening Information Data Set (SIDS)	OECD SIDS Initial Assessment Profile (SIAP) (OECD 2007)
European Commission (EC), European Chemicals Bureau	European Union Risk Assessment Report, Hexabromocyclododecane CASRN 25637-99-4, EINECS No: 247-148-4 (EINECS 2008)
United Nations Environment Programme (UNEP); United Nations Stockholm Convention on Persistent Organic Pollutants (POPs)	Hexabromocyclododecane Draft Risk Profile (UNEP 2010a) Hexabromocyclododecane Risk Management Evaluation (2011) (UNEP 2011)
Environment Canada and Health Canada	Draft Screening Assessment of Hexabromocyclododecane (EC/HC 2011)
Australian Government Department of Health, National Industrial Chemicals Notification and Assessment Scheme (NICNAS)	Priority Existing Chemical Assessment Report, Hexabromocyclododecane (NICNAS 2012a)

1.4 Scope of the Evaluation

1.4.1 Conditions of Use Included in the Risk Evaluation

TSCA Section 3(4) defines the conditions of use as “*the circumstances, as determined by the Administrator, under which a chemical substance is intended, known, or reasonably foreseen to be manufactured, processed, distributed in commerce, used, or disposed of.*” To determine the conditions of use of HBCD and inversely, activities that do not qualify as conditions of use, EPA conducted extensive research and outreach, as described in detail in *Problem Formulation Document for Cyclic Aliphatic Bromide Cluster (HBCD)* ([U.S. EPA 2018g](#)). Section 1.2 above summarizes these findings and provides any additional information that was obtained since the publication of that document. EPA did not evaluate activities that EPA concluded do not constitute conditions of use – for example, because EPA has insufficient information to find certain activities are circumstances under which the chemical is actually “intended, known, or reasonably foreseen to be manufactured, processed, distributed in commerce, used, or disposed of.” EPA did not exclude from this final risk evaluation any use constituted to be COU and a determination was made on each COU.

Based on the information described in Section 1.2, EPA evaluated the importation of HBCD; processing of HBCD into automobile replacement parts and use of HBCD in such parts; processing of HBCD into solder paste and use of HBCD in solder paste; incorporation into formulation, mixture or reaction product (*e.g.*, compounding of masterbatch XPS); the processing of HBCD for incorporation into articles (*e.g.*, manufacture of EPS and XPS and the manufacture of structural insulated panels from EPS and XPS); the industrial, commercial and consumer use of EPS and XPS in construction materials (*e.g.*, insulation boards) and in plastic and other articles; distribution; disposal (demolition); and recycling of XPS and EPS foam, resin, and panels containing HBCD and recycling of electronic waste containing HIPS that contains HBCD.

Table 1-8 presents the conditions of use and associated exposure scenarios that are considered within the scope of the Risk Evaluation during various life cycle stages including manufacturing, processing, use (industrial, commercial, and consumer), distribution and disposal. The information is grouped according to Chemical Data Reporting (CDR) processing codes and use categories (including functional use codes for industrial uses and product categories for industrial, commercial and consumer uses), in combination with other data sources (*e.g.*, published literature and consultation with stakeholders) to provide an overview of conditions of use. EPA notes that some subcategories of use may be grouped under multiple CDR categories.

Use categories include the following: “industrial use” means use at a site at which one or more chemicals or mixtures are manufactured (including imported) or processed. “Commercial use” means the use of a chemical or a mixture containing a chemical (including as part of an article) in a commercial enterprise providing saleable goods or services. “Consumer use” means the use of a chemical or a mixture containing a chemical (including as part of an article, such as furniture or clothing) when sold to or made available to consumers for their use ([U.S. EPA 2016d](#)).

To understand conditions of use relative to one another and associated potential exposures under those conditions of use, Figure 1-1 depicts the life cycle diagram and includes the production volume associated with each stage of the life cycle. The life cycle diagram for HBCD does not include specific production volumes because the information was claimed as confidential business information (CBI) in the 2016 CDR reporting ([U.S. EPA 2016d](#)).

Table 1-8. Categories and Subcategories of Conditions of Use and Corresponding Exposure Scenario Included in the Scope of the Risk Evaluation for HBCD ^a

Life Cycle Stage	Category ^a	Subcategory ^b	Occupational/ Environmental Exposure Scenario ^c	Consumer Exposure Scenario	References
Manufacture	Import	Import	Section 2.4.1.2 – Repackaging of Import Containers (1)	N/A	(U.S. EPA 2016d)
Processing	Incorporated into formulation, mixture or reaction product	Flame retardants used in custom compounding of resin (<i>e.g.</i> , compounding in XPS masterbatch) and in solder paste	Section 2.4.1.3 – Compounding of Polystyrene Resin to Produce XPS Masterbatch (2)	N/A	(EINECS 2008); (U.S. EPA 2017g)
			Section 2.4.1.12 – Formulation of Flux/Solder Pastes (11)		
	Incorporated into article	Flame retardants used in plastics product manufacturing (manufacture of XPS and EPS foam; manufacture of structural insulated panels (SIPS) and automobile replacement parts from XPS and EPS foam)	Section 2.4.1.4 – Processing of HBCD to produce XPS Foam using XPS Masterbatch (3)	N/A	Use Document, EPA-HQ-OPPT-2016-0735-0003 ; Market Profile, EPA-HQ-OPPT-2016-0735-0049 ; (Alliance of Automobile Manufacturers 2018a).
			Section 2.2.5 – Processing of HBCD to produce XPS Foam using HBCD Powder (4)		
Section 2.4.1.6 – Processing of HBCD to produce EPS Foam from Imported EPS Resin Beads (5)					
Section 2.4.1.7 – Processing of HBCD to produce SIPS and Automobile Replacement Parts from XPS/EPS Foam (6)					
Recycling	Recycling	Recycling of XPS and EPS foam, resin, panels containing HBCD	Section 2.4.1.11 – Recycling of EPS Foam and Reuse of XPS Foam (10)	N/A	Use Document, EPA-HQ-OPPT-2016-0735-0003
		Recycling of electronics waste containing HIPS that contain HBCD	Section 2.4.1.14– Recycling of electronics waste containing HIPS (13)		
Distribution	Distribution	Distribution	Activities related to distribution (<i>e.g.</i> , loading, unloading) are considered throughout the life cycle, rather than using a single distribution scenario.		

Life Cycle Stage	Category ^a	Subcategory ^b	Occupational/ Environmental Exposure Scenario ^c	Consumer Exposure Scenario	References
Commercial/ consumer Use	Building/construction materials	Plastic articles (hard): construction and building materials covering large surface areas (<i>e.g.</i> , XPS/EPS foam insulation in residential, public and commercial buildings, and other structures) and solder paste	Section 2.4.1.9 – Installation of XPS/EPS Foam Insulation in Residential, Public, and Commercial Buildings, and Other Structures (8) Section 2.4.1.13 – Use of Flux/Solder Pastes (12)	Section 2.4.2.3 – Consumer Exposures during Use of HBCD in XPS/EPS Insulation in Residences and Auto Components	Use Document, EPA-HQ-OPPT-2016-0735-0003 ; (U.S. EPA 2016d); (U.S. EPA 2014d)
	Other	Automobile replacement parts	Section 2.4.1.8 – Installation of Automobile Replacement Parts (7)	Section 2.4.2.3 – Consumer Exposures During Use of HBCD in XPS/EPS Insulation in Residences and Auto Components N/A	(Alliance of Automobile Manufacturers 2018a)
		Plastic and other articles ^d		Section 2.4.4.4 – Mouthing of Articles Containing HBCD	(Abdallah et al. 2018 ; Vojta et al. 2017)
		Formulated products (<i>e.g.</i> , adhesives and coatings) and articles (<i>e.g.</i> , textiles, electrical and electronic products)	Section 2.4.2.2.6 – Occupational Microenvironments (Workers); Section 2.4.2 – General Population Background Exposure (General Population and Consumers) Section 2.3.2.1 – Non-Scenario Specific Approach (Environmental; Aquatic organisms); Section 2.3.3.1 and 2.3.3.3 – Non-Scenario Specific Approach (Environmental; Terrestrial organisms)	Section 2.4.2 – General Population Background Exposure (Consumers)	
Disposal	Disposal	Land disposal of construction and demolition waste	Section 2.4.1.10 – Demolition and Disposal of XPS/EPS Foam Insulation Products in Residential, Public and Commercial Buildings, and Other Structures (9)	N/A	(EINECS 2008)

Life Cycle Stage	Category ^a	Subcategory ^b	Occupational/ Environmental Exposure Scenario ^c	Consumer Exposure Scenario	References
		Land disposal of formulated products (<i>e.g.</i> , adhesives and coatings) and articles (<i>e.g.</i> , textiles, electrical and electronic products)	Section 2.4.5.3 – Occupational Exposure Associated with Land Disposal of Formulated Products and Articles (Workers); Section 2.4.2 – General Population Background Exposure (General Population and Consumers); Section 2.3.2.1 – Non-Scenario Specific Approach (Environmental)		
<p>^a These categories of conditions of use appear in the Life Cycle Diagram, reflect CDR codes, and broadly represent conditions of use of HBCD in industrial and/or commercial settings.</p> <p>^b These subcategories reflect more specific uses of HBCD.</p> <p>^c Exposure scenarios are numbered in parentheses. This numbering will be referred to throughout the document, including for exposure subscenarios (<i>e.g.</i>, 3.1, 3.2, etc.)</p> <p>^d This COU was inadvertently omitted from Table 1-8 in the draft Risk evaluation.</p>					

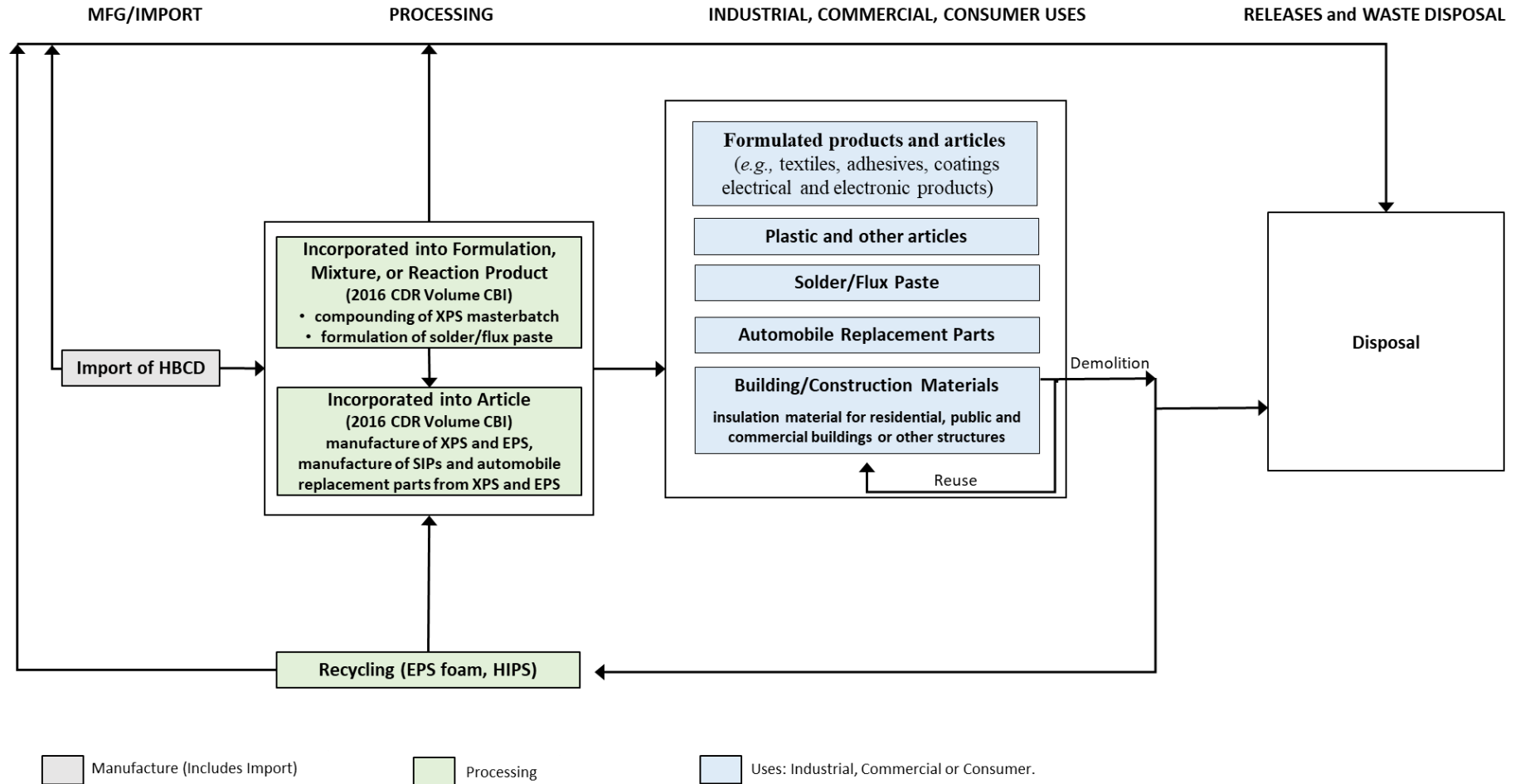

Figure 1-1. HBCD Life Cycle Diagram

The life cycle diagram depicts the conditions of use that are within the scope of the Risk Evaluation during various life cycle stages including manufacturing, processing, use (industrial, commercial, consumer), distribution and disposal. Activities related to distribution (*e.g.*, loading, unloading) will be considered throughout the HBCD life cycle, rather than using a single distribution scenario.

1.4.2 Exposure Pathways and Risks Addressed by other EPA Administered Statutes

In its TSCA section 6(b) risk evaluations, EPA is coordinating action on certain exposure pathways and risks falling under the jurisdiction of other EPA-administered statutes or regulatory programs. More specifically, EPA is exercising its TSCA authorities to tailor the scope of its risk evaluations, rather than focusing on environmental exposure pathways addressed under other EPA-administered statutes or regulatory programs or risks that could be eliminated or reduced to a sufficient extent by actions taken under other EPA-administered laws. EPA considers this approach to be a reasonable exercise of the Agency's TSCA authorities, which include:

- TSCA section 6(b)(4)(D): “The Administrator shall, not later than 6 months after the initiation of a risk evaluation, publish the scope of the risk evaluation to be conducted, including the hazards, exposures, conditions of use, and the potentially exposed or susceptible subpopulations the Administrator expects to consider...”
- TSCA section 9(b)(1): “The Administrator shall coordinate actions taken under this chapter with actions taken under other Federal laws administered in whole or in part by the Administrator. If the Administrator determines that a risk to health or the environment associated with a chemical substance or mixture could be eliminated or reduced to a sufficient extent by actions taken under the authorities contained in such other Federal laws, the Administrator shall use such authorities to protect against such risk unless the Administrator determines, in the Administrator's discretion, that it is in the public interest to protect against such risk by actions taken under this chapter.”
- TSCA section 9(e): “...[I]f the Administrator obtains information related to exposures or releases of a chemical substance or mixture that may be prevented or reduced under another Federal law, including a law not administered by the Administrator, the Administrator shall make such information available to the relevant Federal agency or office of the Environmental Protection Agency.”
- TSCA section 2(c): “It is the intent of Congress that the Administrator shall carry out this chapter in a reasonable and prudent manner, and that the Administrator shall consider the environmental, economic, and social impact of any action the Administrator takes or proposes as provided under this chapter.”
- TSCA section 18(d)(1): “Nothing in this chapter, nor any amendment made by the Frank R. Lautenberg Chemical Safety for the 21st Century Act, nor any rule, standard of performance, risk evaluation, or scientific assessment implemented pursuant to this chapter, shall affect the right of a State or a political subdivision of a State to adopt or enforce any rule, standard of performance, risk evaluation, scientific assessment, or any other protection for public health or the environment that— (i) is adopted or authorized under the authority of any other Federal law or adopted to satisfy or obtain authorization or approval under any other Federal law...”

1.4.2.1 TSCA Authorities Supporting Tailored Risk Evaluations and Intra-agency Referrals

TSCA section 6(b)(4)(D)

TSCA section 6(b)(4)(D) requires EPA, in developing the scope of a risk evaluation, to identify the hazards, exposures, conditions of use, and potentially exposed or susceptible subpopulations the Agency “expects to consider” in a risk evaluation. This language suggests that EPA is not required to consider all conditions of use, hazards, or exposure pathways in risk evaluations. As EPA explained in the

“Procedures for Chemical Risk Evaluation Under the Amended Toxic Substances Control Act” (“Risk Evaluation Rule”), EPA may, on a case-by-case basis, tailor the scope of the risk evaluation “to focus its analytical efforts on those exposures that are likely to present the greatest concern, and consequently merit an unreasonable risk determination.” 82 FR 33726, 33729 (July 20, 2017).

In the Problem Formulation documents for many of the first 10 chemicals undergoing risk evaluation, EPA applied the same authority and rationale to certain exposure pathways, explaining that “EPA is planning to exercise its discretion under TSCA 6(b)(4)(D) to focus its analytical efforts on exposures that are likely to present the greatest concern and consequently merit a risk evaluation under TSCA, by excluding, on a case-by-case basis, certain exposure pathways that fall under the jurisdiction of other EPA-administered statutes.” This approach is informed by the legislative history of the amended TSCA, which supports the Agency’s exercise of discretion to focus the risk evaluation on areas that raise the greatest potential for risk. See June 7, 2016 Cong. Rec., S3519-S3520. Consistent with the approach articulated in the Problem Formulation documents, and as described in more detail below, EPA is exercising its authority under TSCA to tailor the scope of exposures evaluated in TSCA risk evaluations, rather than focusing on environmental exposure pathways addressed under other EPA-administered, media-specific statutes and regulatory programs.

TSCA section 9(b)(1)

In addition to TSCA section 6(b)(4)(D), the Agency also has discretionary authority under the first sentence of TSCA section 9(b)(1) to “coordinate actions taken under [TSCA] with actions taken under other Federal laws administered in whole or in part by the Administrator.” This broad, freestanding authority provides for intra-agency coordination and cooperation on a range of “actions.” In EPA’s view, the phrase “actions taken under [TSCA]” in the first sentence of section 9(b)(1) is reasonably read to encompass more than just risk management actions, and to include actions taken during risk evaluation as well. More specifically, the authority to coordinate intra-agency actions exists regardless of whether the Administrator has first made a definitive finding of risk, formally determined that such risk could be eliminated or reduced to a sufficient extent by actions taken under authorities in other EPA-administered Federal laws, and/or made any associated finding as to whether it is in the public interest to protect against such risk by actions taken under TSCA. TSCA section 9(b)(1) therefore provides EPA authority to coordinate actions with other EPA offices without ever making a risk finding or following an identification of risk. This includes coordination on tailoring the scope of TSCA risk evaluations to focus on areas of greatest concern rather than exposure pathways addressed by other EPA-administered statutes and regulatory programs, which does not involve a risk determination or public interest finding under TSCA section 9(b)(2).

In a narrower application of the broad authority provided by the first sentence of TSCA section 9(b)(1), the remaining provisions of section 9(b)(1) provide EPA authority to identify risks and refer certain of those risks for action by other EPA offices. Under the second sentence of section 9(b)(1), “[i]f the Administrator determines that a risk to health or the environment associated with a chemical substance or mixture could be eliminated or reduced to a sufficient extent by actions taken under the authorities contained in such other Federal laws, the Administrator shall use such authorities to protect against such risk unless the Administrator determines, in the Administrator’s discretion, that it is in the public interest to protect against such risk by actions taken under [TSCA].” Coordination of intra-agency action on risks under TSCA section 9(b)(1) therefore entails both an identification of risk, and a referral of any risk that could be eliminated or reduced to a sufficient extent under other EPA-administered laws to the EPA office(s) responsible for implementing those laws (absent a finding that it is in the public interest to protect against the risk by actions taken under TSCA).

Risk may be identified by OPPT or another EPA office, and the form of the identification may vary. For instance, OPPT may find that one or more conditions of use for a chemical substance present(s) a risk to human or ecological receptors through specific exposure routes and/or pathways. This could involve a quantitative or qualitative assessment of risk based on reasonably available information (which might include, e.g., findings or statements by other EPA offices or other federal agencies). Alternatively, risk could be identified by another EPA office. For example, another EPA office administering non-TSCA authorities may have sufficient monitoring or modeling data to indicate that a particular COU presents risk to certain human or ecological receptors, based on expected hazards and exposures. This risk finding could be informed by information made available to the relevant office under TSCA section 9(e), which supports cooperative actions through coordinated information-sharing.

Following an identification of risk, EPA would determine if that risk could be eliminated or reduced to a sufficient extent by actions taken under authorities in other EPA-administered laws. If so, TSCA requires EPA to “use such authorities to protect against such risk,” unless EPA determines that it is in the public interest to protect against that risk by actions taken under TSCA. In some instances, EPA may find that a risk could be sufficiently reduced or eliminated by future action taken under non-TSCA authority. This might include, e.g., action taken under the authority of the Safe Drinking Water Act (SDWA) to address risk to the general population from contaminants in drinking water, particularly if the Office of Water has taken preliminary steps such as listing the subject chemical substance on the Contaminant Candidate List. This sort of risk finding and referral could occur during the risk evaluation process, thereby enabling EPA to use a more relevant and appropriate authority administered by another EPA office to protect against hazards or exposures to affected receptors.

Legislative history on TSCA section 9(b)(1) supports both broad coordination on current intra-agency actions, and narrower coordination when risk is identified and referred to another EPA office for action. A Conference Report from the time of TSCA’s passage explained that section 9 is intended “to assure that overlapping or duplicative regulation is avoided while attempting to provide for the greatest possible measure of protection to health and the environment.” S. Rep. No. 94-1302 at 84. See also H. Rep. No. 114-176 at 28 (stating that the 2016 TSCA amendments “reinforce TSCA’s original purpose of filling gaps in Federal law,” and citing new language in section 9(b)(2) intended “to focus the Administrator’s exercise of discretion regarding which statute to apply and to encourage decisions that avoid confusion, complication, and duplication”). Exercising TSCA section 9(b)(1) authority to coordinate on tailoring TSCA risk evaluations is consistent with this expression of Congressional intent.

Legislative history also supports a reading of section 9(b)(1) under which EPA coordinates intra-agency action, including information-sharing under TSCA section 9(e), and the appropriately-positioned EPA office is responsible for the identification of risk and actions to protect against such risks. See, e.g., Senate Report 114-67, 2016 Cong. Rec. S3522 (under TSCA section 9, “if the Administrator finds that disposal of a chemical substance may pose risks that could be prevented or reduced under the Solid Waste Disposal Act, the Administrator should ensure that the relevant office of the EPA receives that information”); H. Rep. No. 114-176 at 28, 2016 Cong. Rec. S3522 (under section 9, “if the Administrator determines that a risk to health or the environment associated with disposal of a chemical substance could be eliminated or reduced to a sufficient extent under the Solid Waste Disposal Act, the Administrator should use those authorities to protect against the risk”). Legislative history on section 9(b)(1) therefore supports coordination with and referral of action to other EPA offices, especially when statutes and associated regulatory programs administered by those offices could address exposure pathways or risks associated with conditions of use, hazards, and/or exposure pathways that may otherwise be within the scope of TSCA risk evaluations.

TSCA sections 2(c) and 18(d)

Finally, TSCA sections 2(c) and 18(d) support coordinated action on exposure pathways and risks addressed by other EPA-administered statutes and regulatory programs. Section 2(c) directs EPA to carry out TSCA in a “reasonable and prudent manner” and to consider “the environmental, economic, and social impact” of its actions under TSCA. Legislative history from around the time of TSCA’s passage indicates that Congress intended EPA to consider the context and take into account the impacts of each action under TSCA. S. Rep. No. 94-698 at 14 (“the intent of Congress as stated in this subsection should guide each action the Administrator takes under other sections of the bill”).

Section 18(d)(1) specifies that state actions adopted or authorized under any Federal law are not preempted by an order of no unreasonable risk issued pursuant to TSCA section 6(i)(1) or a rule to address unreasonable risk issued under TSCA section 6(a). Thus, even if a risk evaluation were to address exposures or risks that are otherwise addressed by other federal laws and, for example, implemented by states, the state laws implementing those federal requirements would not be preempted. In such a case, both the other federal and state laws, as well as any TSCA section 6(i)(1) order or TSCA section 6(a) rule, would apply to the same issue area. See also TSCA section 18(d)(1)(A)(iii). In legislative history on amended TSCA pertaining to section 18(d), Congress opined that “[t]his approach is appropriate for the considerable body of law regulating chemical releases to the environment, such as air and water quality, where the states have traditionally had a significant regulatory role and often have a uniquely local concern.” Sen. Rep. 114-67 at 26.

EPA’s careful consideration of whether other EPA-administered authorities are available, and more appropriate, for addressing certain exposures and risks is consistent with this Congressional intent to maintain existing federal requirements and the state actions adopted to locally and more specifically implement those federal requirements, and to carry out TSCA in a reasonable and prudent manner. EPA believes it is both reasonable and prudent to tailor TSCA risk evaluations in a manner reflective of expertise and experience exercised by other EPA and State offices to address specific environmental media, rather than attempt to evaluate and regulate potential exposures and risks from those media under TSCA. This approach furthers Congressional direction and EPA aims to efficiently use Agency resources, avoid duplicating efforts taken pursuant to other Agency programs, and meet the statutory deadline for completing risk evaluations.

1.4.2.2 EPA-administered Statutes and Regulatory Programs that Address Specific Exposure Pathways and/or Risks

HBCD is not classified as a RCRA hazardous waste. HBCD containing solid wastes are not expected to be sent to Subtitle C incinerators, because HBCD is not a hazardous waste and due to the higher cost of such incineration as compared with MSW or other incinerators; therefore, emissions from hazardous waste incinerators were not evaluated. However, it is possible that HBCD containing solid wastes could be sent to Subtitle C incinerators due to other characteristics of an HBCD containing solid waste mixture.

EPA did not evaluate on-site releases to land that go to underground injection or associated exposures to the general population or terrestrial species in its risk evaluation. Environmental disposal of HBCD injected into Class I well types are covered under the jurisdiction of SDWA and disposal of HBCD via underground injection is not likely to result in environmental and general population exposures. See 40 CFR part 144.

HBCD solid wastes are not required to be disposed of in Subtitle C hazardous waste landfills, however it is possible that HBCD wastes could be disposed this way due to other characteristics of an HBCD containing solid waste mixture. Design standards for Subtitle C landfills require double liner, double leachate collection and removal systems, leak detection system, run on, runoff, and wind dispersal controls, and a construction quality assurance program. They are also subject to closure and post-closure care requirements including installing and maintaining a final cover, continuing operation of the leachate collection and removal system until leachate is no longer detected, maintaining and monitoring the leak detection and groundwater monitoring system. Bulk liquids may not be disposed in Subtitle C landfills. Subtitle C landfill operators are required to implement an analysis and testing program to ensure adequate knowledge of waste being managed, and to train personnel on routine and emergency operations at the facility. Hazardous waste being disposed in Subtitle C landfills must also meet RCRA waste treatment standards before disposal. See 40 CFR part 264.

EPA did not evaluate on-site releases to land from RCRA Subtitle C hazardous waste landfills or exposures of the general population or terrestrial species from such releases in the evaluation. Hazardous waste landfill design and management controls such as coverings, liners, and leachate collection and treatment are expected to adequately mitigate HBCD exposure, therefore, on-site releases to land and exposures of the general population or terrestrial species were not evaluated.

As HBCD is not classified as a RCRA hazardous waste, HBCD containing solid waste may be sent to RCRA Subtitle D municipal solid waste (MSW) landfills particularly for construction demolition disposal. The bulk of the HBCD containing solid waste is due to demolished XPS/EPS foam insulation materials, which would be considered demolition waste. Demolition waste can be sent to MSW landfills, but is expected to be primarily sent to C&D landfills. EPA is not evaluating on-site releases to land from RCRA Subtitle D municipal solid waste (MSW) landfills or exposures of the general population or terrestrial species from such releases in the TSCA evaluation. While permitted and managed by the individual states, municipal solid waste landfills are required by federal regulations to implement some of the same requirements as Subtitle C landfills. MSW landfills generally must have a liner system with leachate collection and conduct groundwater monitoring and corrective action when releases are detected. MSW landfills are also subject to closure and post-closure care requirements and must have financial assurance for funding of any needed corrective actions. MSW landfills have also been designed to allow for the small amounts of hazardous waste generated by households and very small quantity waste generators (less than 220 lbs per month). Bulk liquids, such as free solvent, may not be disposed of at MSW landfills. See 40 CFR part 258.

RCRA Subtitle D municipal solid waste (MSW) landfill design and management controls are expected to adequately mitigate HBCD exposure, therefore, on-site releases to land and exposures of the general population or terrestrial species were not evaluated. A qualitative assessment of leachate was conducted to account for potential releases and exposures from disposal of demolition materials containing HBCD. Since demolition waste can be sent to MSW landfills, but is expected to be primarily sent to C&D landfills the qualitative assessment of leachate covers the disposal of HBCD to landfills including C&D.

1.4.3 Conceptual Models

The conceptual models for this Risk Evaluation are shown below in Figure 1-2, Figure 1-3, Figure 1-4 and Figure 1-5. EPA considered the potential for hazards to human health and the environment resulting from exposure pathways outlined in the preliminary conceptual models of the HBCD scope document ([U.S. EPA 2017e](#)). The conceptual models indicate potential exposures resulting from consumer activities and uses, industrial and commercial activities, and environmental releases and wastes. The

problem formulation documents refined the initial conceptual models and analysis plans that were provided in the scope documents ([U.S. EPA 2018f](#)).

For the purpose of this assessment, EPA considered workers and occupational non-users, which includes men and women of reproductive age (Figure 1-2). Consumer exposure was assessed for various pathways for all age-groups, including adults and children (Figure 1-3). Also, EPA considered exposures to the general population for all age-groups, as well as additional considerations for other exposed groups (Figure 1-3 and Figure 1-4).

EPA has made four modifications to the conceptual model since the publication of the problem formulation document. The first was the addition of the solder/flux paste as a COU based on information reported to the TRI, as discussed in Section 1.2.5.3.

The second change was made to include exposure to liquids for workers associated with solder/flux paste as this use is expected to be in liquid formulations.

The third change was to more fully describe the use of HBCD in recycled products via the mouthing pathway. EPA identified information in the open literature that describes articles which contain HBCD, and recognizes this as an important pathway for infants and young children who may mouth articles. EPA considered mouthing of recycled plastic products using experimental product-testing information on HBCD content in consumer articles. See Section 2.4.4.4. for a more detailed discussion of this exposure scenario.

The last change was the addition of the formulated products and articles as a COU as discussed in Section 1.2.8.

These changes are reflected in the life cycle diagram and conceptual models.

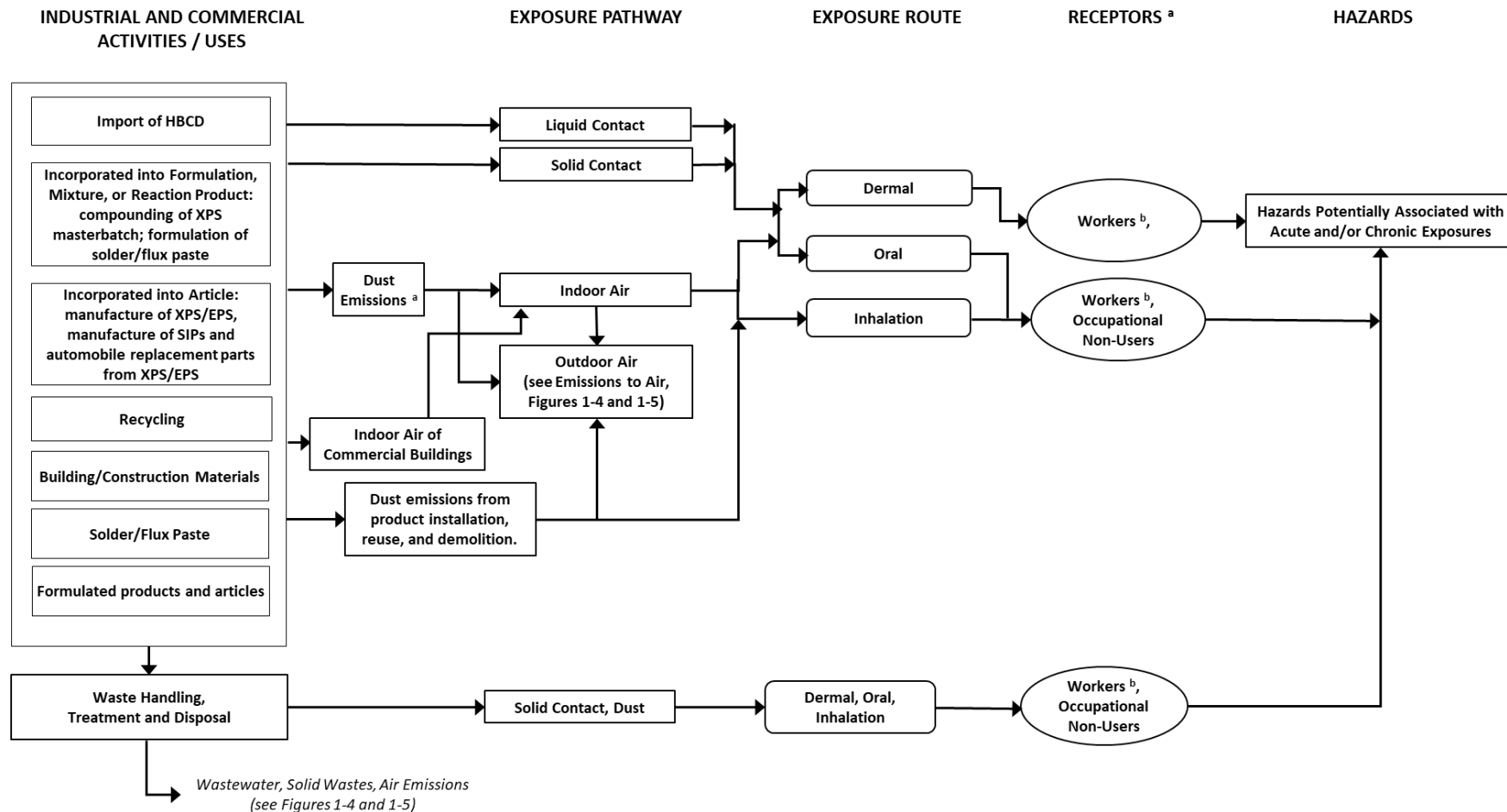

Figure 1-2. HBCD Conceptual Model for Industrial and Commercial Activities and Uses: Worker and Occupational Non-User Exposures and Hazards

The conceptual model presents the exposure pathways, exposure routes and hazards to human receptors from industrial and commercial activities and uses of HBCD.

^a Receptors include potentially exposed or susceptible subpopulations.

^b EPA also considers the effect that engineering controls and personal protective equipment have on occupational exposure levels.

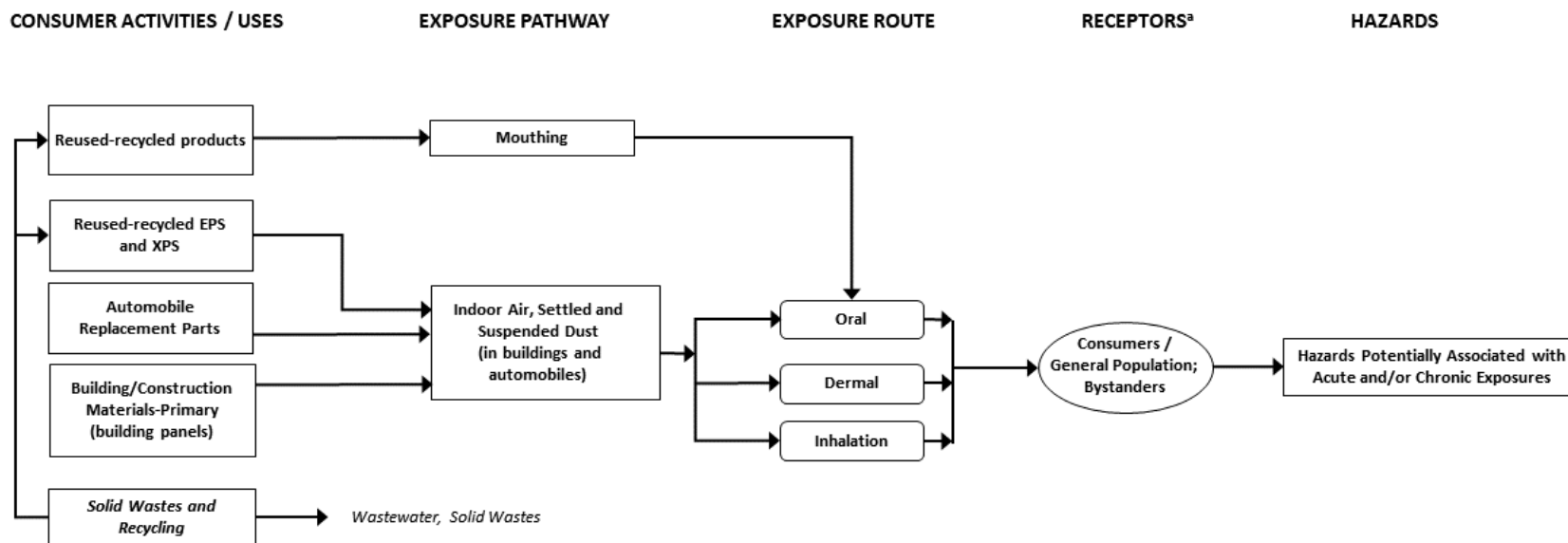

Figure 1-3. HBCD Conceptual Model for Consumer Activities and Uses: Consumer Exposures and Hazards

The conceptual model presents the exposure pathways, exposure routes and hazards to human receptors from consumer activities and uses of HBCD.

^a Receptors include potentially exposed or susceptible subpopulations.

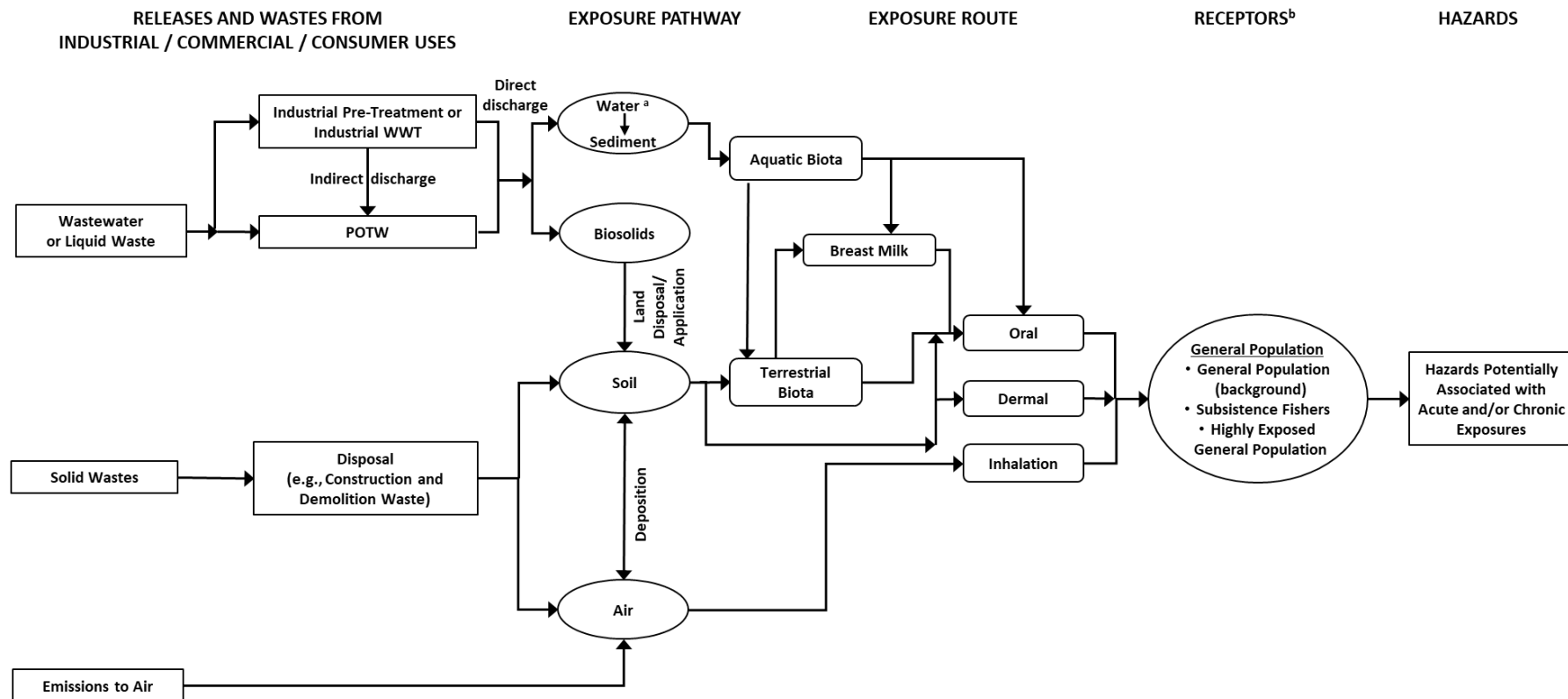

Figure 1-4. HBCD Conceptual Model for Environmental Releases and Wastes: General Population Exposures and Hazards

The conceptual model presents the exposure pathways, exposure routes and hazards to human receptors from releases and wastes from industrial and commercial uses of HBCD.

^a Industrial wastewater or liquid wastes may be treated on-site and then released to surface water (direct discharge), or pre-treated and released to POTW (indirect discharge). For consumer uses, such wastes may be released directly to POTW (*i.e.*, down the drain).

^b Receptors include potentially exposed or susceptible subpopulations.

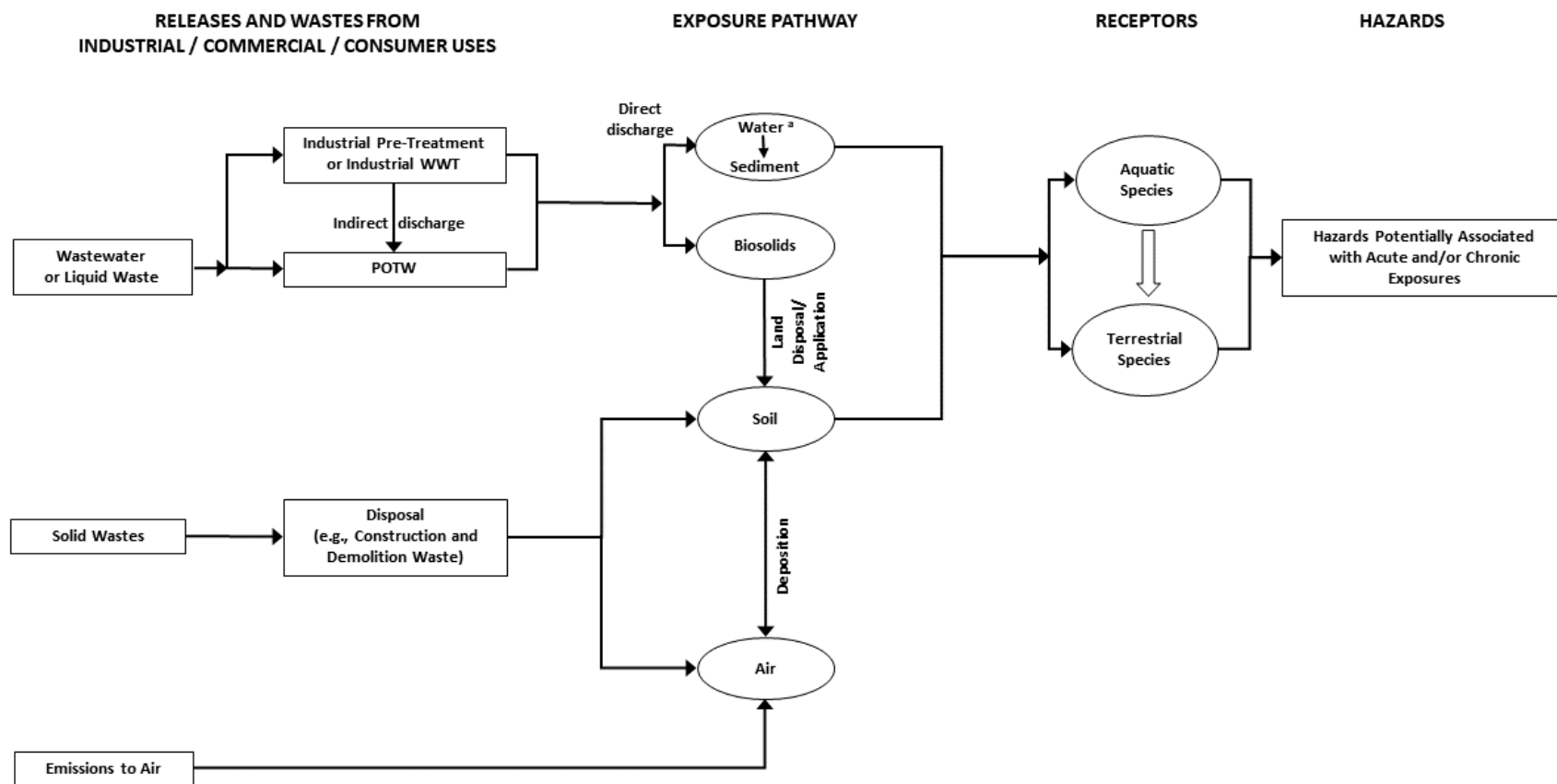

Figure 1-5. HBCD Conceptual Model for Environmental Releases and Wastes: Ecological Exposures and Hazards

The conceptual model presents the exposure pathways and hazards for environmental receptors from industrial and commercial uses of HBCD.

^a Industrial wastewater or liquid wastes may be treated on-site and then released to surface water (direct discharge), or pre-treated and released to POTW (indirect discharge). For consumer uses, such wastes may be released directly to POTW (*i.e.*, down the drain).

1.5 Systematic Review

TSCA requires EPA to use scientific information, technical procedures, measures, methods, protocols, methodologies and models consistent with the best available science when making science-based decisions under Section 6 and base decisions under Section 6 on the weight of scientific evidence. Within the TSCA Risk Evaluation context, the weight of the scientific evidence is defined as “a *systematic review method, applied in a manner suited to the nature of the evidence or decision, that uses a pre-established protocol to comprehensively, objectively, transparently, and consistently identify and evaluate each stream of evidence, including strengths, limitations, and relevance of each study and to integrate evidence as necessary and appropriate based upon strengths, limitations, and relevance.*” (40 C.F.R. 702.33).

To meet the TSCA Section 26(h) science standards, EPA used the TSCA systematic review process described in the *Application of Systematic Review in TSCA Risk Evaluations* document ([U.S. EPA 2018b, c](#)). The process complements the Risk Evaluation process in that the data collection, data evaluation and data integration stages of the systematic review process are used to develop the exposure and hazard assessments based on reasonably available information. EPA defines “reasonably available information” to mean information that EPA possesses, or can reasonably obtain and synthesize for use in Risk Evaluations, considering the deadlines for completing the evaluation ([Risk Evaluation Rule](#), 82 FR 33726).

EPA is implementing systematic review methods and approaches within the regulatory context of the amended TSCA. Although EPA will make an effort to adopt as many best practices as practicable from the systematic review community, EPA modified the process to ensure that the identification, screening, evaluation and integration of data and information can support timely regulatory decision making under the timelines of the statute.

1.5.1 Data and Information Collection

EPA planned and conducted a comprehensive literature search based on key words related to the different discipline-specific evidence supporting the Risk Evaluation (*e.g.*, environmental fate and transport; environmental releases and occupational exposure; exposure to general population, consumers and environmental exposure; and environmental and human health hazards). EPA then developed and applied inclusion and exclusion criteria during the title/abstract screening to identify information potentially relevant for the Risk Evaluation process. The literature and screening strategy as specifically applied to HBCD is described in the *Strategy for Conducting Literature Searches for Cyclic Aliphatic Bromine Cluster (HBCD): Supplemental Document to the TSCA Scope Document* ([U.S. EPA 2017f](#)) and the results of the title and abstract screening process were published in the *Cyclic Aliphatic Bromide Cluster (HBCD) (CASRN: 25637-99-4; 3194-55-6; 3194-57-8) Bibliography: Supplemental File for the TSCA Scope Document* ([U.S. EPA 2017a, b](#)). The screening strategy served to identify relevant studies and exclude only those that were not pertinent to risk assessment of the chemical. No studies were excluded at this step based on data quality evaluation, because only relevant studies were carried forward for data quality evaluation.

For studies determined to be on-topic (or relevant) after title and abstract screening, EPA conducted a full text screening to further exclude references that were not relevant to the Risk Evaluation. Screening decisions were made based on eligibility criteria documented in the form of the populations, exposures,

comparators, and outcomes (PECO) framework or a modified framework¹⁰. Data sources that met the criteria were carried forward to the data evaluation stage. The inclusion and exclusion criteria for full text screening for HBCD are available in Appendix E of the Problem Formulation Document ([U.S. EPA 2018g](#)).

Although EPA conducted a comprehensive search and screening process as described above, EPA generally used previous chemical assessments¹¹ to identify key and supporting information that would be influential in the Risk Evaluation, in other words, information supporting key analyses, arguments, and/or conclusions in the Risk Evaluation. When applicable, EPA also considered newer information not considered in the previous chemical assessments and identified during the comprehensive search. Using this pragmatic approach, EPA evaluated the confidence of the key and supporting data sources as well as newer information instead of evaluating the confidence of all the underlying evidence ever published on HBCD's fate and transport, environmental releases, and environmental and human exposure and hazards. This allowed EPA to maximize the scientific and analytical efforts of other regulatory and non-regulatory agencies by accepting for the most part the scientific knowledge gathered and analyzed by others except for influential information sources that may have an impact on the weight of the scientific evidence and ultimately the risk findings. The influential information (*i.e.*, key/supporting) came from a smaller pool of sources subject to the rigor of the TSCA systematic review process to ensure that the Risk Evaluation uses the best available science and the weight of the scientific evidence.

Although EPA conducted a comprehensive search and screening process as described above, EPA made the decision to leverage the literature published in previous assessments when identifying relevant key and supporting data¹² and information for developing the HBCD Risk Evaluation. This is discussed in the *Strategy for Conducting Literature Searches for Cyclic Aliphatic Bromine Cluster (HBCD): Supplemental Document to the TSCA Scope Document* ([U.S. EPA 2017f](#)). In general, many of the key and supporting data sources were identified in the comprehensive *Cyclic Aliphatic Bromide Cluster (HBCD) (CASRN: 25637-99-4; 3194-55-6; 3194-57-8) Bibliography: Supplemental File for the TSCA Scope Document* ([U.S. EPA 2017a, b](#)). However, there were instances in which EPA missed relevant references that were not captured in the initial categorization of the on-topic references. EPA found additional relevant data and information using backward reference searching, which was a technique that will be included in future search strategies. This issue was discussed in Section 4 of the [Application of Systematic Review for TSCA Risk Evaluations](#). Other relevant key and supporting references were identified through targeted supplemental searches to support the analytical approaches and methods in the HBCD Risk Evaluation (*e.g.*, to locate specific information for exposure modeling) or to identify new data and information published after the date limits of the initial search.

EPA used previous chemical assessments to quickly identify relevant key and supporting information as a pragmatic approach to expedite the quality evaluation of the data sources, but many of those data sources were already captured in the comprehensive literature as explained above. EPA also considered

¹⁰ A PESO statement was used during the full text screening of environmental fate and transport data sources. PESO stands for Pathways and Processes, Exposure, Setting or Scenario, and Outcomes. A RESO statement was used during the full text screening of the engineering and occupational exposure literature. RESO stands for Receptors, Exposure, Setting or Scenario, and Outcomes.

¹¹ Examples of existing assessments are EPA's chemical assessments (*e.g.*, previous work plan risk assessments, problem formulation documents), ATSDR's Toxicological Profiles, EPA's IRIS assessments and ECHA's dossiers. This is described in more detail in the *Strategy for Conducting Literature Searches for Cyclic Aliphatic Bromine Cluster (HBCD): Supplemental Document to the TSCA Scope Document* ([U.S. EPA 2017f](#)).

¹² Key and supporting data and information are those that support key analyses, arguments, and/or conclusions in the risk evaluation.

newer information not taken into account by previous chemical assessments as described in the *Strategy for Conducting Literature Searches for Cyclic Aliphatic Bromine Cluster (HBCD): Supplemental Document to the TSCA Scope Document* (U.S. EPA 2017f). EPA then evaluated the confidence of the key and supporting data sources as well as newer information instead of evaluating the confidence of all the underlying evidence ever published on a chemical substance's fate and transport, environmental releases, environmental and human exposure and hazards. This allowed EPA to maximize the scientific and analytical efforts of other regulatory and non-regulatory agencies by accepting for the most part the relevant scientific knowledge gathered and analyzed by others except for influential information sources that may have an impact on the weight of the scientific evidence and ultimately the risk findings. The influential information (*i.e.*, key/supporting) would come from a smaller pool of sources subject to the rigor of the TSCA systematic review process to ensure that the Risk Evaluation uses the best available science and the weight of the scientific evidence.

Figure 1-6 to Figure 1-10 depict literature flow diagrams illustrating the results of this process for each scientific discipline-specific evidence supporting the Risk Evaluation. Each diagram provides the total number of references at the start of each systematic review stage (*i.e.*, data search, data screening, data evaluation, data extraction/data integration) and those excluded based on criteria guiding the screening and data quality evaluation decisions.

EPA made the decision to bypass the data screening step for data sources that were highly relevant to the Risk Evaluation as described above. These data sources are depicted as “key/supporting data sources” in the literature flow diagrams. The number of “key/supporting data sources” were excluded from the total count during the data screening stage and added, for the most part, to the data evaluation stage depending on the discipline-specific evidence. The exception was the environmental releases and occupational exposure data sources that were subject to a combined data extraction and evaluation step (Figure 1-7).

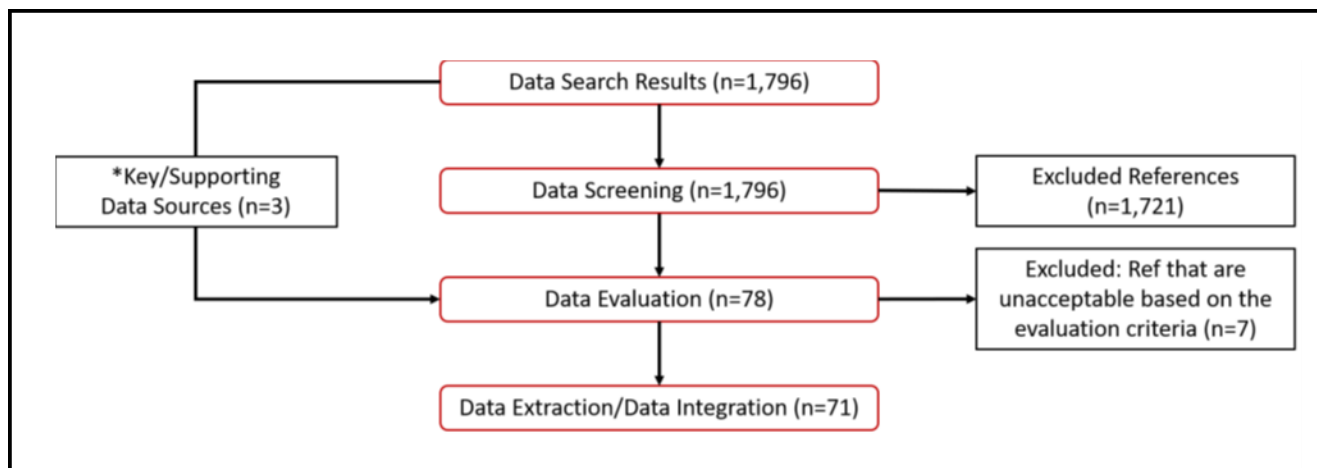
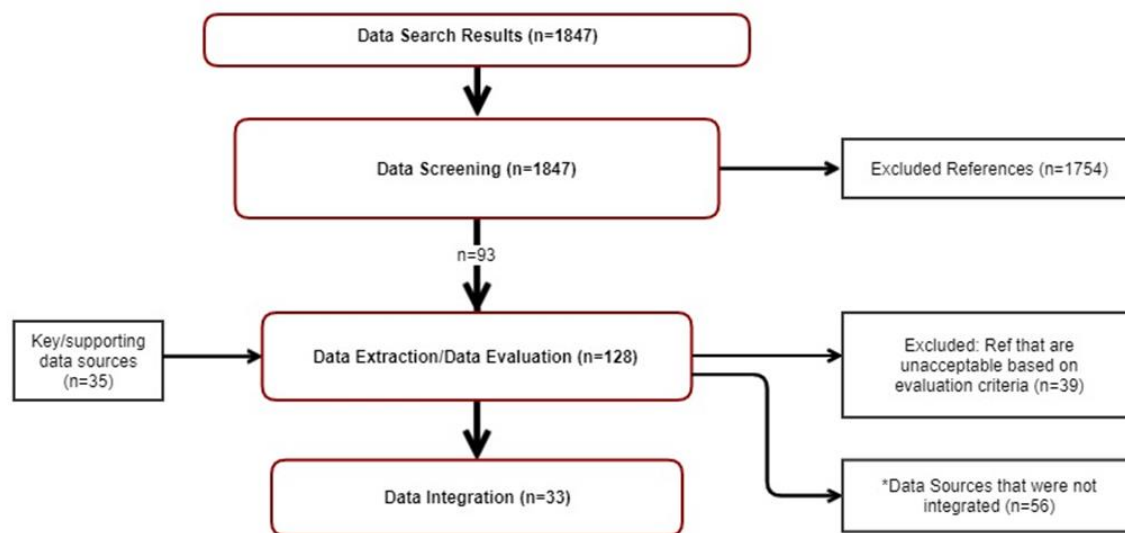

Figure 1-6. HBCD Literature Flow Diagram for Environmental Fate and Transport Data Sources Literature search results for the environmental fate and transport of HBCD yielded 1,796 studies. Of these studies, 1,721 were determined to be off topic. The remaining 75 studies entered full text screening for the determination of relevance to the Risk Evaluation. Seven studies were deemed unacceptable based on the evaluation criteria for fate and transport studies and the remaining 68 studies were carried forward to data extraction/data integration.

* These are key and supporting studies from existing assessments (e.g., EPA IRIS assessments, ATSDR assessments, ECHA dossiers) that were considered highly relevant for the TSCA Risk Evaluation. These studies bypassed the data screening step and moved directly to the data evaluation step.



*The quality of data in these sources (n=56) were acceptable for risk evaluation purposes, but they were ultimately excluded from further consideration based on EPA's integration approach for environmental release and occupational exposure data/information. EPA's approach uses a hierarchy of preferences that guide decisions about what types of data/information are included for further analysis, synthesis and integration into the environmental release and occupational exposure assessments. EPA prefers using data with the highest rated quality among those in the higher level of the hierarchy of preferences (i.e., data > modeling > occupational exposure limits or release limits). If warranted, EPA may use data/information of lower rated quality as supportive evidence in the environmental release and occupational exposure assessments.

Figure 1-7. HBCD Literature Flow Diagram for Environmental Releases and Occupational Exposure Data Sources

Literature search results for environmental release and occupational exposure yielded 1,847 data sources. Of these data sources, 93 were determined to be relevant for the risk evaluation through the data screening process. These relevant data sources were entered into the data extraction/evaluation phase. After data extraction/evaluation, EPA identified several data gaps and performed a supplemental, targeted search to fill these gaps (e.g. to locate information needed for exposure modeling). The supplemental search yielded 35 relevant data sources that bypassed the data screening step and were evaluated and extracted in accordance with *Appendix D: Data Quality Criteria for Occupational Exposure and Release Data of the Application of Systematic Review for TSCA Risk Evaluations* document.

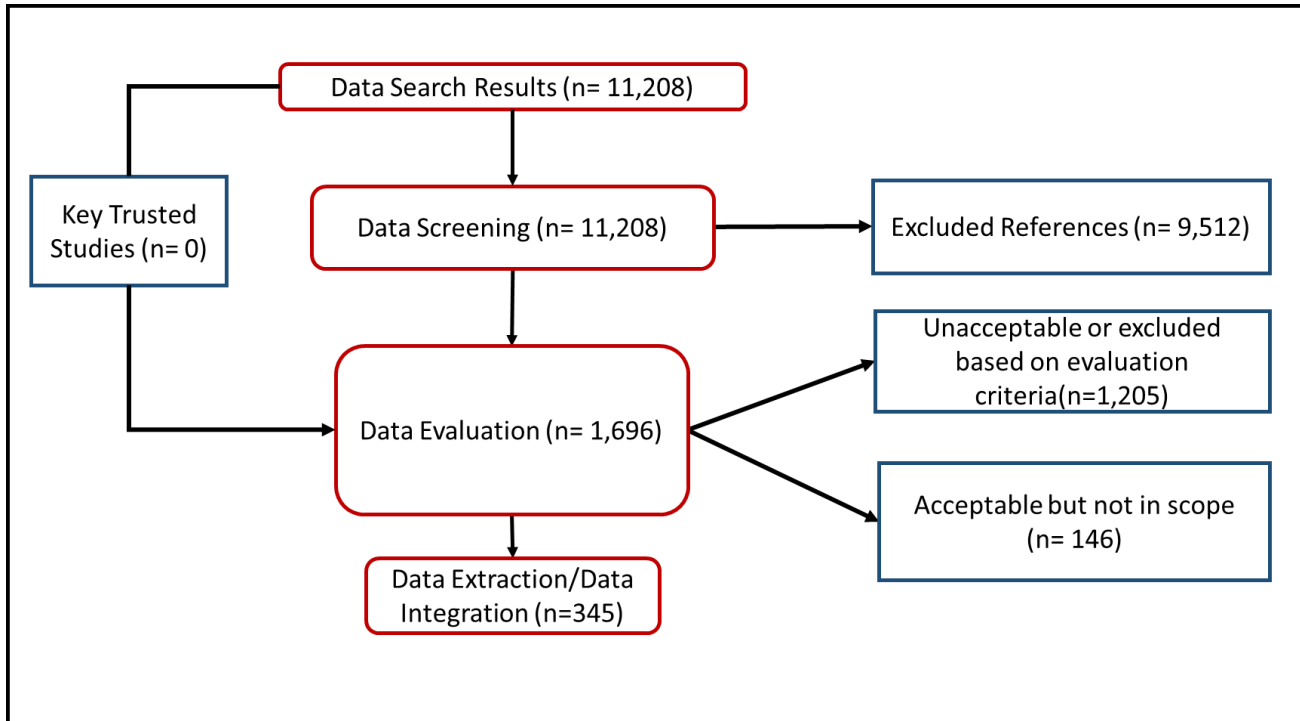

Figure 1-8. Literature Flow Diagram for General Population, Consumer and Environmental Exposure Data Sources for HBCD

EPA conducted a literature search to determine relevant data sources for assessing exposures for HBCD within the scope of the Risk Evaluation. This search identified 11,208 data sources including relevant supplemental documents. Of these, 9,512 were excluded during the screening of the title, abstract, and/or full text and 1,696 data sources were recommended for data evaluation across up to five major study types in accordance with *Appendix E: Data Quality Criteria for Studies on Consumer, General Population and Environmental Exposure of the Application of Systematic Review for TSCA Risk Evaluations* document. (U.S. EPA 2018c). Following the evaluation process, 345 references were forwarded for further extraction and data integration.

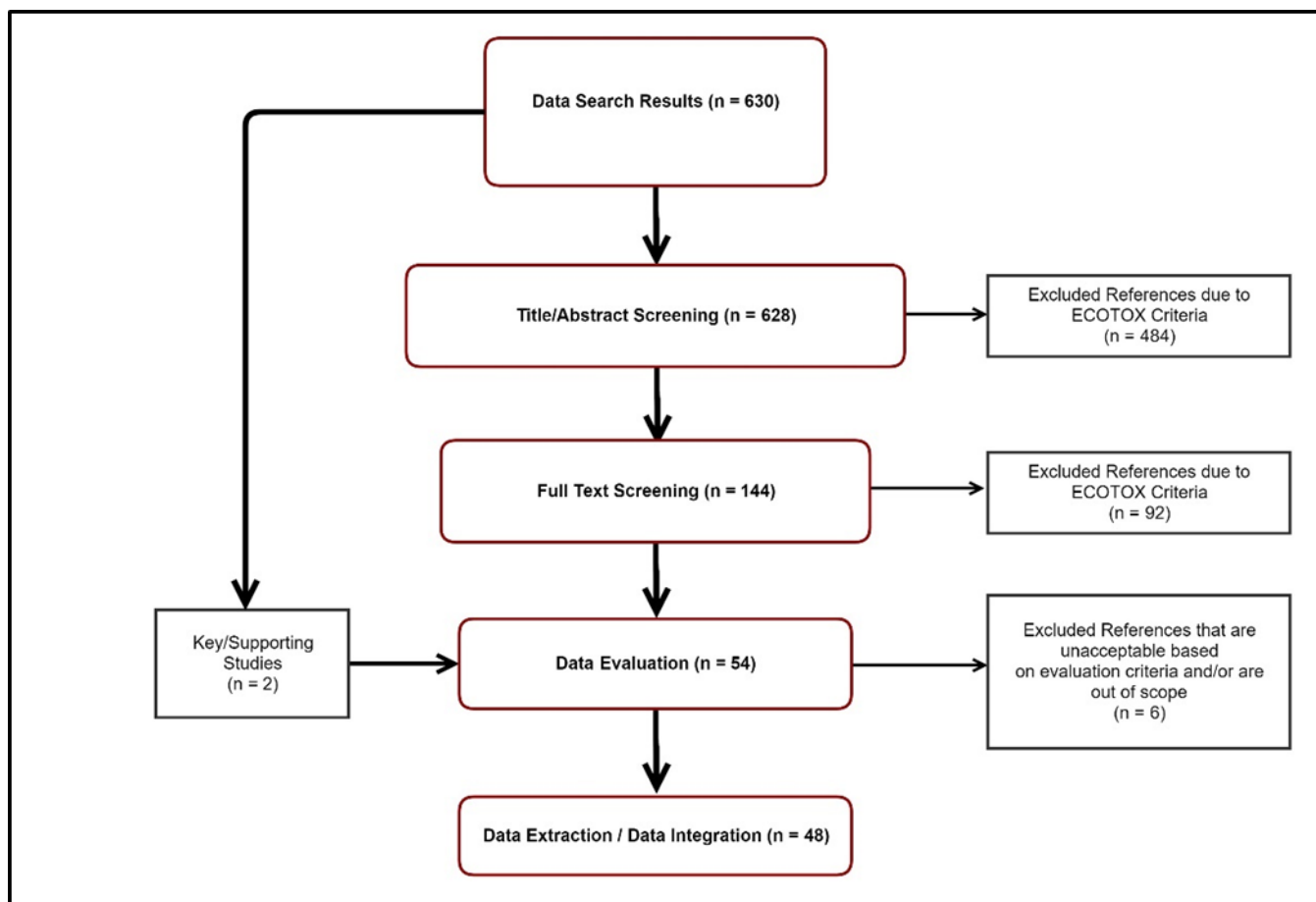

Figure 1-9. Literature Flow Diagram for Environmental Hazard Data Sources for HBCD

The environmental hazard data sources were identified through literature searches and screening strategies using the ECOTOXicology Knowledgebase System (ECOTOX) Standing Operating Procedures. For studies determined to be on-topic after title and abstract screening, EPA conducted a full text screening to further exclude references that were not relevant to the Risk Evaluation. Screening decisions were made based on eligibility criteria as documented in the ECOTOX User Guide ([U.S. EPA 2018e](#)). Additional details can be found in the *Strategy for Conducting Literature Searches for Hexabromocyclododecane Supplemental Document to the TSCA Scope Document* ([U.S. EPA 2018h](#)).

The “Key/Supporting Studies” box represents data sources typically cited in existing assessments and considered highly relevant for the TSCA Risk Evaluation because they were used as key and supporting information by regulatory and non-regulatory organizations to support their chemical hazard and risk assessments. These citations were found independently from the ECOTOX process. These studies bypassed the data screening step and moved directly to the data evaluation step.

Studies could be considered “out of scope” after the screening steps, and therefore excluded from data evaluation, due to the elimination of pathways during problem formulation.

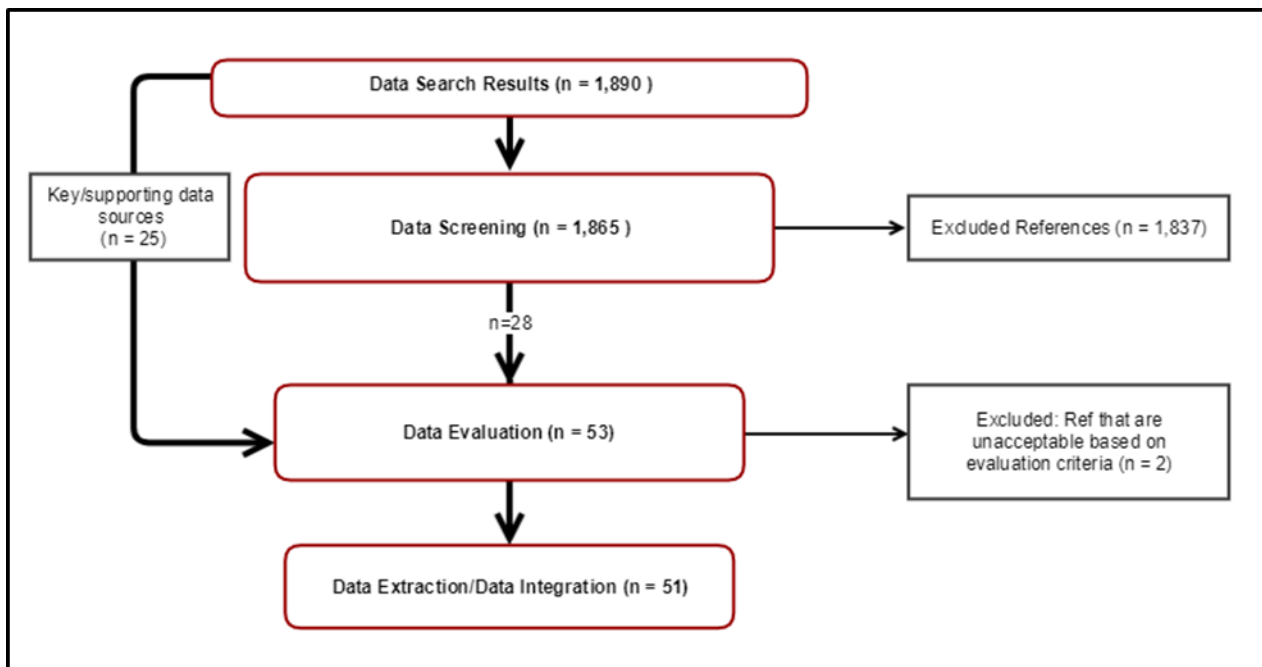

Figure 1-10. Literature Flow Diagram for Human Health Hazard Key/Supporting Data Sources for HBCD

Literature search results for human health hazard of HBCD yielded 1,890 studies. This included 25 key and supporting studies identified from previous EPA assessments (see Section 3.2.1). Of the 1,865 new studies screened for relevance, 1,837 were excluded as off topic. The remaining 28 new studies together with the 25 key and supporting studies entered full text screening for the determination of relevance to the Risk Evaluation. Two studies were deemed unacceptable based on the evaluation criteria human health hazard and the remaining 51 studies were carried forward to data extraction/data integration.

Data integration includes analysis, synthesis and integration of information for the Risk Evaluation. During data integration and analysis, EPA considers quality, consistency, relevancy, coherence and biological plausibility to make final conclusions regarding the weight of the scientific evidence. As stated in the *Application of Systematic Review in TSCA Risk Evaluations* ([U.S. EPA 2018b](#)), data integration involves transparently discussing the significant issues, strengths, and limitations as well as the uncertainties of the reasonably available information and the major points of interpretation ([U.S. EPA 2018h](#)).

2 EXPOSURES

This section describes EPA's approach to assessing environmental and human exposures. First, the fate and transport of HBCD in the environment is characterized. Then, releases of HBCD into the environment are assessed. Last, this information is integrated into an assessment of occupational, general population (including highly exposed subpopulations), and environmental exposures for HBCD. For all exposure-related disciplines, EPA screened, evaluated, extracted, and integrated available empirical data. In addition, EPA used models to estimate exposures. Both empirical data and modeled estimates were considered when selecting values for use in the exposure assessment.

Exposure equations and selected values used in the exposure assessment are presented in the following sections. More specific information is provided in *Risk Evaluation for Cyclic Aliphatic Bromide Cluster (HBCD), Supplemental Information on General Population, Environmental, and Consumer Exposure Assessment*.

Following the inclusion of HBCD on EPA's workplan list in 2012, EPA published a 2015 problem formulation prior to passage of the Lautenberg amendments, and published an updated scope in 2017 and problem formulation document in 2018. EPA has incorporated the following refinements based on public comments and review of data since initial work began on HBCD.

- More complete assessment of human dietary exposure from multiple sources (estimates for all food groups and more specific estimates for breast milk ingestion and fish ingestion) for the general population,
- Inclusion of dermal pathway,
- Inclusion of refined models used to estimate surface water and ambient air as well as sediment and indoor dust,
- Inclusion of additional contextual information from monitoring data to determine which data is likely more applicable to exposure scenarios of interest, and
- Assessment of bioaccumulation and wildlife as part of environmental exposure assessment.

2.1 Fate and Transport

The environmental fate studies considered for this Risk Evaluation are summarized in Appendix C. This information is based on studies published in ([U.S. EPA 2015a](#), [2014d](#); [NICNAS 2012a](#); [EC/HC 2011](#); [EINECS 2008](#); [U.S. EPA 2008a](#); [OECD 2007](#)) and was supplemented by an updated literature search following problem formulation.

2.1.1 Fate and Transport Approach and Methodology

EPA gathered and evaluated environmental fate information according to the process described in the *Application of Systematic Review in TSCA Risk Evaluations* ([U.S. EPA 2018b](#)). Reasonably available environmental fate information was used in the current evaluation. Furthermore, EPA used previous regulatory and non-regulatory chemical assessments of HBCD to inform the environmental fate and transport information discussed in this section and Appendix C. EPA had confidence in the information used in the previous assessments to describe the environmental fate and transport of HBCD based on scientific review of the methodologies and quality of the data presented and thus used it to make risk evaluation decisions.

EPA also used the previous assessment to identify key and supporting fate information that would be influential in the Risk Evaluation, as described in Section 1.5.1. For instance, EPA assessed the quality

of an HBCD aerobic freshwater sediment biodegradation study ([Davis et al. 2006](#)) based on the data quality criteria described in the *Application of Systematic Review in TSCA Risk Evaluations* ([U.S. EPA 2018b](#)) and the study was rated ‘high’ confidence. The atmospheric oxidation half-life fate estimate was based on modeling results from EPI Suite™ ([U.S. EPA 2012b](#)), a predictive tool for physical/chemical and environmental fate properties. The data evaluation table describing the review of these studies as well as other studies included in Table 2-1 can be found in the supplemental document, *Data Quality Evaluation of Environmental Fate and Transport Studies* ([U.S. EPA 2019I](#)).

The HBCD environmental fate characteristics and physical-chemical properties used in fate assessment are presented in Table 2-1. EPA used EPI Suite™ estimations and reasonably available fate information to characterize the environmental fate and transport of HBCD. As part of problem formulation, EPA also analyzed the fate of HBCD in air, water, soil, sediment, and bioaccumulation. The results of the analyses are described in the 2018 problem formulation for HBCD ([U.S. EPA 2018g](#)) and presented again in Appendix C. This section and Appendix C may also cite other data sources as part of the reasonably available information on the fate and transport properties of HBCD. EPA did not subject these other data sources to the later phases of the systematic review process (*i.e.*, data evaluation and integration) as explained in Section 1.5.1.

2.1.2 Summary of Fate and Transport

Environmental fate includes both transport and transformation processes. Environmental transport is the movement of the chemical within and between environmental media. Transformation generally occurs through the degradation or reaction of the chemical with other species in the environment. Hence, knowledge of the environmental fate of the chemical informs the determination of the specific exposure pathways and potential human and environmental receptors EPA analyzed in the Risk Evaluation.

Table 2-1 provides a summary of a subset of the environmental fate data that EPA identified, evaluated and considered in the Risk Evaluation for HBCD. A full list of data considered, identified and evaluated is provided in Appendix C.

Table 2-1. Summary of Environmental Fate and Transport Properties for HBCD

Property	Value	Reference	Study Quality
Indirect Photolysis	Half-life 2.1 days in air (estimated)	(U.S. EPA 2015a)	NA
Hydrolysis	Not expected due to lack of functional groups that hydrolyze under environmental conditions and low water solubility (estimated)	(ECHA 2008b)	NA
Aerobic Biodegradation in Water	No biodegradation observed in 28-day closed-bottle test Organisation for Economic Co-operation and Development (OECD) Guideline 301D, EPA OTS 796.3200	(Wildlife Intl 1996)	Medium
Aerobic Biodegradation in Sediment	Half-life: 128, 92, and 72 days for α -, γ -, and β -HBCD, respectively (estimated), based on a 44% decrease in total initial radioactivity in viable freshwater sediment of ¹⁴ C-labeled HBCD (4.67 mg/kg dry weight) after 112 days; method based on OECD 308	(Davis et al. 2006)	High
	Half-life: >120 days (estimated), based on a 15% decrease in total initial radioactivity in abiotic freshwater sediment of ¹⁴ C-labeled HBCD (4.67 mg/kg dry weight) after 112 days; method based on OECD 308		High

Property	Value	Reference	Study Quality
	Half-life: 11 and 32 days (estimated) in viable sediment collected from Schuylkill River and Neshaminy creek, respectively, using nominal HBCD concentrations of 0.034–0.089 mg/kg; method based on OECD 308	(Davis et al. 2005)	High
	Half-life: 190 and 30 days (estimated) in abiotic sediment collected from Schuylkill River and Neshaminy creek, respectively, using nominal HBCD concentrations of 0.034–0.089 mg/kg; method based on OECD 308		High
	Half-life: 92 days (estimated), based on a 61% decrease in total initial radioactivity in viable freshwater sediment of 14C-labeled HBCD (4.31 mg/kg dry weight) after 113 days; method based on OECD 308	(Davis et al. 2006)	High
	Half-life: >120 days (estimated), based on a 33% decrease in total initial radioactivity in abiotic freshwater sediment of 14C-labeled HBCD (4.31 mg/kg dry weight) after 113 days; method based on OECD 308		High
	Half-life: 1.5 and 1.1 days (estimated) in viable sediment collected from Schuylkill River and Neshaminy creek, respectively, using nominal HBCD concentrations of 0.063–0.089 mg/kg; method based on OECD 308	(Davis et al. 2005)	High
	Half-life: 10 and 9.9 days (estimated) in abiotic sediment collected from Schuylkill River and Neshaminy creek, respectively, using nominal HBCD concentrations of 0.063–0.089 mg/kg; method based on OECD 308		High
Aerobic Biodegradation in Soil	Half-life: >120 days (estimated), based on a 10% decrease in total initial radioactivity in viable soil of 14C-labeled HBCD after 113 days; method based on OECD 307 using HBCD at 3.04 mg/kg dry weight	(Davis et al. 2006)	High
	Half-life: >120 days (estimated), based on a 6% decrease in total initial radioactivity in abiotic soil of 14C-labeled HBCD after 113 days; method based on OECD 307 using HBCD at 3.04 mg/kg dry weight		High
	Half-life: 63 days (estimated) in viable soil amended with activated sludge using a nominal HBCD concentration of 0.025 mg/kg dry weight; method based on OECD 307	(Davis et al. 2005)	High
	Half-life: >120 days (estimated) in abiotic soil using a nominal HBCD concentration of 0.025 mg/kg dry weight; method based on OECD 307		High
	Half-life: 6.9 days (estimated) in viable soil amended with activated sludge using a nominal HBCD concentration of 0.025 mg/kg dry weight; method based on OECD 307		High
	Half-life: 82 days (estimated) in abiotic soil using a nominal HBCD concentration of 0.025 mg/kg dry weight; method based on OECD 307		High

Property	Value	Reference	Study Quality
Soil organic carbon:water partition coefficient (log K_{oc})	Log K _{oc} = 4.9 (79,433) estimated	(U.S. EPA 2015a)	NA
	Log K _{oc} > 5 (> 100,000) OECD Guideline 121 Estimation of the Adsorption Coefficient (K _{oc}) on Soil and on Sewage Sludge using High Performance Liquid Chromatography (HPLC)	(ECHA 2017a)	High
Field Measured Bioaccumulation Factor (BAF)	Upper trophic level lipid normalized BAF for total HBCDs of approximately 90,090,000 calculated from the mean HBCD lipid normalized fish tissue concentration and the HBCD dissolved water concentration.	(He et al. 2013)	High
	Wet weight BAF 290,880		
	Upper trophic level lipid normalized BAF for total HBCDs of approximately 3,120,000 calculated from the mean HBCD lipid normalized fish tissue concentration and the HBCD dissolved water concentration.	(Wu et al. 2011)	High
Bioconcentration Factor (BCF)	fathead minnow 18,100 (whole body)	(Veith et al. 1979)	High
	^a BCF (steady state, edible portion) rainbow trout 4650 at 1.8 µg/L exposure concentration) BCF rainbow trout (kinetic, edible portion) 14,039 calculated at 0.18 µg/L exposure concentration)	Drottar (Wildlife Intl 2000) as cited in (ECHA 2008b)	High

^a HBCD exposure concentrations 1.8 and 0.18 µg/L. Steady state achieved at 1.8 ug/L but not at 0.18 ug/L

2.1.2.1 Air

HBCD is not expected to undergo significant direct photolysis since it does not absorb radiation in the environmentally available region of the electromagnetic spectrum that has the potential to cause molecular degradation ([HSDB 2008](#)). HBCD in the vapor phase will be degraded by reaction with photochemically produced hydroxyl radicals in the atmosphere. A half-life of 2.1 days was calculated from an estimated rate constant of 5.01×10^{-12} cm³/molecules-second at 25 °C, assuming an atmospheric hydroxyl radical concentration of 1.5×10^6 molecules/cm³ and a 12-hour day ([U.S. EPA 2011a, 1993a](#)). Based on an estimated octanol air partition coefficient (K_{oa}) of 1.6×10^9 , HBCD is expected to associate strongly with airborne particulates. HBCD associated with particulates is expected to be less subject to hydroxy radical oxidation in the atmosphere and primarily removed from the atmosphere through wet or dry deposition.

2.1.2.2 Water

HBCD is not expected to undergo hydrolysis in environmental waters because of its lack of hydrolyzable functional groups. Based on a measured soil organic carbon:water partition coefficient (K_{oc}) of >100,000, HBCD is expected to partition from the water column, bind strongly to and be transported with suspended and benthic sediments. A Henry's Law constant of 6×10^{-6} atm-m³/mol at 25 °C, calculated based on a vapor pressure of 4.70×10^{-7} mm Hg at 21 °C and a water solubility of 66 µg/L at 25 °C, indicates that HBCD may volatilize slowly from moist soil and water surfaces. However, adsorption to suspended solids and sediment will reduce the rate of volatilization from water. An OECD 301D ready biodegradability study (aerobic aqueous medium) on HBCD resulted in no observed biodegradation in 28 days, suggesting that aerobic biodegradation in the water column may not be rapid ([Wildlife Intl 1996](#)).

2.1.2.3 Soil and Sediment

Based on a measured K_{oc} value of $>100,000$ HBCD is expected to bind strongly to soil, sediment, and suspended organic matter. It may undergo abiotic and microbial degradation while associated with solids. Tests with viable microbes demonstrated increased HBCD degradation compared to the biologically inhibited control studies. In combination, these studies suggest that HBCD will degrade slowly in the environment, although faster in sediment than in soil, faster under anaerobic conditions than aerobic conditions, faster with microbial action than without microbial action, and at different rates for individual HBCD diastereomers (slower for α -HBCD than for the γ - and β - stereoisomers). The biodegradation half-lives for aerobic sediment and aerobic soil calculated from (Davis et al. 2006) and (Davis et al. 2005) were used for the assessment. HBCD has been reported to undergo abiotic degradation in aerobic and anaerobic sediment and aerobic soil (ECHA 2008b; Davis et al. 2006) (see Figure 2-1). The degradation was attributed to abiotic reductive dehalogenation which can form tetrabromo and dibromocyclododecane and 1,5,9-cyclododecatriene. Further degradation of 1,5,9-cyclododecatriene was not observed.

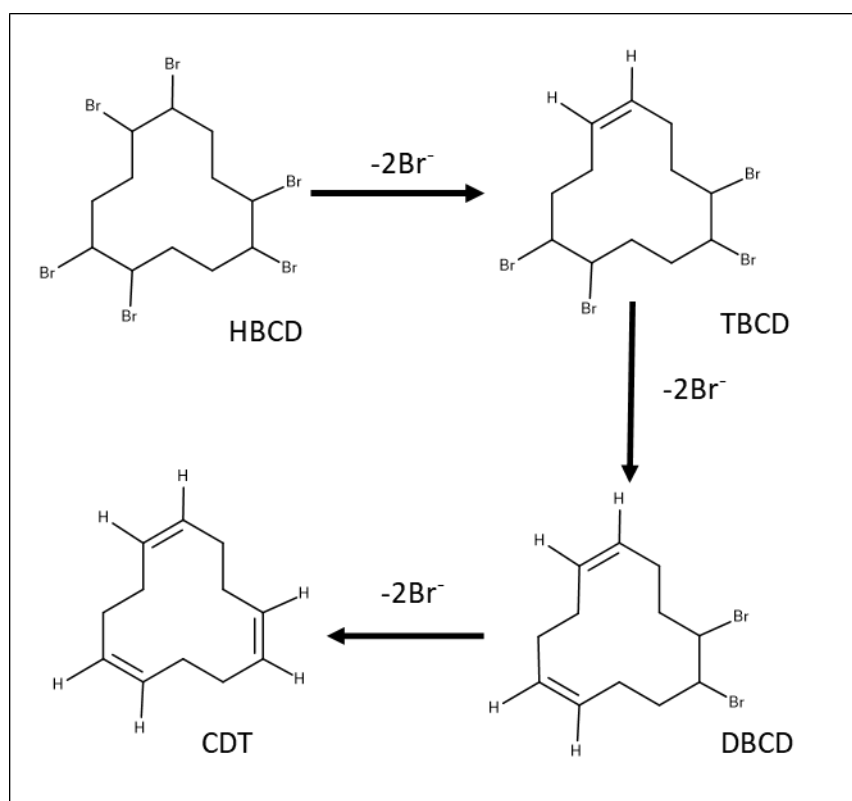

Figure 2-1. Abiotic Reduction of HBCD to 5,6,9,10-tetrabromocyclododec-1-ene (TBCD), 9,10-dibromocyclododeca-1,5-diene (DBCD), and 1,5,9-cyclododecatriene (CDT) in Aerobic and Anaerobic Sediments (Davis et al. 2006).

2.1.2.4 Wastewater Treatment Plants

No information was found on the removal of HBCD in Publicly Owned Treatment Works (POTWs) in the United States. However, a study on the removal of HBCD in sewage treatment systems in the Yodo river basin in Japan was identified and reviewed. (Ichihara et al. 2014) measured influent and effluent concentrations of HBCD diastereoisomers in 12 sewage treatment plants in the river basin. The range of removal rates was 80 – 99% with an average of 93% removal. Considering the low volatility and biodegradability of HBCD, the removal was most likely due to sorption to activated sludge solids. The

EPA EPISuite STP (Sewage Treatment Plant) model was run for HBCD to provide additional information on HBCD removal. The model simulates an activated sludge wastewater treatment system and includes the processes of volatilization, adsorption to sludge and biodegradation. The model was run using the physical-chemical properties reported in Section 1.1, Table 1-1. The biodegradation half-life was set at 10,000 hours, a default for a non-biodegradable substance. The model calculated approximately 90% removal of HBCD by adsorption to sludge with less than 1% removed by biodegradation and volatilization. No information on the treatability of HBCD bound to plastic particles was found. However, based on the density of these particles a qualitative assessment of their fate in activated sludge systems can be made. Considering the low volatility and biodegradability of HBCD these processes are not likely important. Dense particulate HBCD and HBCD associated with polystyrene beads are expected to be removed with sludge during the sludge settling process. Less dense HBCD associated with polystyrene foam may be removed in clarification by skimmers designed to remove floating matter. Based on these findings, HBCD entering activated sludge wastewater treatment systems is expected to be removed with a treatment efficiency in the range of 90% primarily by adsorption to sludge. Volatilization and biodegradation of HBCD are not expected to be important removal processes. Sludge bound HBCD may be further processed or disposed of by several methods including land application.

2.1.2.5 Persistence

Based on the studies described later in this section HBCD is expected to be persistent in soil, surface water and groundwater. It may biodegrade slowly under aerobic and anaerobic conditions with half-lives on the order of months.

2.1.2.6 Bioaccumulation/Bioconcentration

Bioaccumulation and bioconcentration in aquatic and terrestrial organisms, including humans, are important environmental processes for HBCD. Bioconcentration is the net accumulation of a chemical by an aquatic organism as a result of uptake directly from the ambient water, through gill membranes or other external body surfaces. Bioaccumulation is the net accumulation of a chemical by an aquatic organism as a result of uptake from all environmental sources. For hydrophobic chemicals such as HBCD, aquatic organisms are exposed via both the diet and ambient water. Thus, bioaccumulation measurements for HBCD more accurately reflect the contribution of all the routes by which aquatic organisms are exposed.

Bioaccumulation factors were calculated for freshwater food webs in industrialized areas of Southern China in two separate field studies. He et al. ([He et al. 2013](#)) calculated lipid normalized log BAFs of 4.8 – 7.7 (corresponding to BAFs of 63,000 – 50,000,000) for HBCD diastereomer in carp, tilapia, and catfish, and found higher BAFs for α -HBCD than β - and γ -HBCD. Wu et al. ([Wu et al. 2011](#)) calculated log BAFs of 2.85 – 5.98 for the total of all HBCD diastereomers (corresponding to BAFs of 700 – 950,000) in a freshwater food web. Log BAFs for each diastereomer in this study were comparable to one another (see Appendix C.2). La Guardia et al. ([La Guardia et al. 2012](#)) calculated log BAFs in bivalves and gastropods collected downstream of a textile manufacturing outfall; these ranged from 4.2 to 5.3 for α - and β -HBCD (BAFs of 16,000 – 200,000), and from 3.2 to 4.8 for γ -HBCD (BAFs of 1,600 – 63,000).

Drottar and Kruger, ([Wildlife Intl LTD 2000](#)) as cited in ([ECHA 2008b](#)) measured BCF values ranging from 8,974 to 13,085 for HBCD in rainbow trout. Veith et al. ([Veith et al. 1979](#)) measured a BCF of 18,100 for HBCD in fathead minnows. These BCF values indicate that HBCD exhibits very high bioconcentration in fish. Widespread detection of this substance in aquatic organisms is further evidence that HBCD bioconcentrates ([Marvin et al. 2011](#); [ECHA 2008b](#); [Covaci et al. 2006](#)). HBCD has also

been shown to biomagnify. Based on measurements of HBCD in invertebrates, fish, birds, and marine mammals, biomagnification of HBCD in the aquatic food web is evident, with the highest levels of HBCD measured in seals and porpoises ([Shaw et al. 2012](#); [Letcher et al. 2009](#); [ECHA 2008b](#); [Covaci et al. 2006](#); [De Boer et al. 2002](#)). Terrestrial food chain bioaccumulation has also been demonstrated. In a study using breeding peregrine falcon populations in northern and southwestern Sweden, HBCD concentrations were measured in the eggs of two groups of wild falcons and one group of captive falcons fed only domestic chickens not exposed to HBCD. HBCD was not detected in the eggs of the captive falcons but 150 and 250 ng/g lipid was measured in the eggs of the northern and southwestern populations, respectively, indicating that HBCD bioaccumulation in terrestrial food chains may also be important ([Lindberg et al. 2004](#)).

2.1.2.7 PBT Characterization

HBCD has been found to meet the criteria for Persistent, Bioaccumulative and Toxic (PBT) chemicals in assessments conducted by EPA's TRI Program ([U.S. EPA 2016e](#)), ECB (European Chemicals Bureau) ([ECHA 2008b](#)), Environment Canada/Health Canada ([EC/HC 2011](#)) and NICNAS ([NICNAS 2012a](#)).

In 2016, EPA finalized a rule adding a hexabromocyclododecane (HBCD) category to the Toxics Release Inventory (TRI) list of reportable chemicals with a 100-pound reporting threshold. EPA set reporting threshold for the Toxics Release Inventory (TRI) HBCD category after determining that it meets the criteria for a PBT chemical. For purposes of EPCRA section 313 reporting, EPA established persistence half-life criteria for PBT chemicals of 2 months in water/sediment and soil and 2 days in air, and established bioaccumulation criteria for PBT chemicals as a bioconcentration factor (BCF) or bioaccumulation factor (BAF) of 1,000 or higher.

In its HBCD risk assessment the European Chemicals Bureau determined that while HBCD does not unequivocally fulfill the specific P (persistence) criterion, with some reliable studies indicating that biodegradation can occur, it does not degrade rapidly, and monitoring data indicate a significant degree of environmental transport and overall stability. The HBCD BCF of 18,100 selected for use in the risk assessment met the vB (very bioaccumulative) criterion. T (toxicity) criterion was found to be fulfilled according to available data. The risk assessment further noted that HBCD is ubiquitous in the environment, being also found in remote areas far away from point sources. The presence of the highest concentrations of HBCD in marine top-predators such as porpoise and seals provides evidence that HBCD bioaccumulates up the food chain. Based on an overall assessment it was concluded that HBCD has PBT properties according to the PBT criteria of the Technical Guidance Document (TGD; [ECB 2003](#)).

Environment Canada/Health Canada in its Screening Assessment Report on Hexabromocyclododecane determined HBCD meets the criteria for persistence in water, soil, and sediment as outlined in the *Persistence and Bioaccumulation Regulations* under CEPA 1999 (*i.e.*, half-life in water and soil of 182 days or more, and half-life in sediment of 365 days or more). Additionally, HBCD meets the criteria for persistence in air set out in the same regulations (*i.e.*, half-life of two days or more, or being subject to atmospheric transport from the source to a remote area), and the criteria for bioaccumulation as specified in the *Persistence and Bioaccumulation Regulations* under CEPA 1999 (*i.e.*, bioaccumulation factors [BAFs] or bioconcentration factors [BCFs] of 5000 or more).

The Australian Government Department of Health, National Industrial Chemicals Notice and Assessment Scheme (NICNAS) compared the PBT characteristics of HBCD to Australian PBT criteria and POPs criteria described in the United Nations Stockholm Convention on Persistent Organic Pollutants. Based on laboratory data and international environmental monitoring data, sufficient

evidence was found to conclude that HBCD will persist in the environment and meets both Australian and POPs criteria for persistence. Data provided through both laboratory testing and environmental sampling of biota show the chemical (particularly the α isomer) is highly bioaccumulative and can be biomagnified through the food chain. HBCD meets both Australian and POPs criteria for bioaccumulation.

2.1.3 Assumptions and Key Sources of Uncertainty for Fate and Transport

Biodegradation Half-Lives

A range of aerobic and anaerobic biodegradation half-lives and bioaccumulation and bioconcentration values have been reported for HBCD. The range of biodegradation half-lives reported were measured in laboratory studies based on OECD methods for biodegradation in water, soil and sediment. These studies are subject to several sources of variability including the specific microbial populations used, water, soil and sediment chemistry, oxygen concentration/redox potential of the collected samples used in the study, temperature and test substance concentration as well as variability inherent in the methodology and interlaboratory variability. No single value of bioconcentration or bioaccumulation is universally applicable as it is influenced by these variables and possibly others. However, the results of these studies do inform the range of environmental half-lives HBCD might exhibit.

Media specific biodegradation half-lives selected for use in the Risk Evaluation are used as input to the VVWM-PSC environmental exposure model discussed further in Section 2.3.2.2.2. Due to the partitioning properties of HBCD its major pathway is expected to be partitioning to sediments where it is subject to biodegradation. The use of a range of half-lives for aerobic sediment are recommended below. The selection of shorter half-lives in the range as input to the model will result in lower concentrations of HBCD in sediments and lower exposures to sediment dwelling organisms, possibly reducing risk estimates for benthic organisms compared to using half-lives at the longer end of the range.

Half-lives estimated from studies ranged from days to greater than 6 months. Taken as a whole, the studies demonstrate that under some conditions HBCD may undergo some degree of biodegradation (complete biodegradation has not been reported) while under other conditions it does not appreciably biodegrade. When this information is combined with environmental monitoring showing the presence of HBCD in dated sediment cores it can be concluded that HBCD is persistent in the environment. Furthermore, multiple jurisdictions have agreed, based on the available scientific evidence, that HBCD meets criteria for persistence under their regulatory schemes (see Section 2.1.2.7 PBT Characterization)

Although a broad range of biodegradation half-lives for HBCD have been reported in laboratory studies using aerobic and anaerobic soils and sediments and a single study of the biodegradation of HBCD in water has been reviewed, a limited number of quantitative half-life ranges were selected for use in the environmental and general population exposure assessments. Three studies ([Davis et al. 2006](#); [Davis et al. 2005](#); [Wildlife Intl 1996](#)) were used to assess the biodegradation half-lives of HBCD. Studies were selected for use in the Risk Evaluation based of their relevance to the routes of entry of HBCD into the environment. Releases of HBCD in particulate form to air and water are expected from several industrial activities. Based on the environmental transport properties of HBCD, releases to air are expected to be subject to wet and dry deposition to water bodies and soil. HBCD entering water bodies is not expected to be present at high levels in solution, but to sorb to suspended solids and ultimately deposit to sediments. HBCD deposited to soil is expected to sorb strongly with little movement through the soil column. Soil bound HBCD can enter water through run-off. Thus, half-lives for water, soil and sediment were determined to be most relevant for the Risk Evaluation. The assumption that HBCD enters aerobic sediments leads to the use of aerobic sediment biodegradation half-lives for this medium. As discussed further below, HBCD aerobic biodegradation half-lives are longer than anaerobic half-lives for soil (63

to greater than 120 days aerobic vs 6.9 days anaerobic) and sediment (11 to 128 days aerobic vs 1.1 to 92 days anaerobic). The use of the longer aerobic sediment biodegradation half-lives as input to the environmental exposure model used in the Risk Evaluation will result in higher concentrations of HBCD in sediments, possibly increasing risk estimates for benthic organisms compared to using anaerobic sediment biodegradation half-lives at the shorter end of the range. Soil biodegradation half-lives were not used as input to exposure models because monitored soil concentrations were available and were used to assess soil related exposure. Thus, the selection of a particular soil biodegradation half-life did not impact the exposure or Risk Evaluation.

An OECD 301D Closed Bottle Ready Biodegradability test (aerobic aqueous medium) on HBCD resulted in no observed biodegradation in days. This result suggests that aerobic biodegradation in the water column will not be rapid. Adsorption to suspended solids with subsequent deposition to the upper layer of sediment is likely a more rapid process than biodegradation in the water column. Thus, sediment half-life in the upper sediment layer is more relevant than the water column half-life. It is assumed that the upper layer of sediments is aerobic. HBCD released to air and deposited on soil surfaces is assumed to sorb strongly and remain in the surface layer where aerobic conditions prevail. Thus, aerobic soil biodegradation half-lives are considered most relevant for the soil compartment.

Two studies ([Davis et al. 2006](#); [Davis et al. 2005](#)) were selected to assess the biodegradation half-life of HBCD in aerobic soils and aerobic sediments. Davis et al. (2005) and Davis et al. (2006), reported aerobic soil biodegradation half-lives ranging from 63 days to greater than 120 days in viable test systems. Aerobic sediment biodegradation half-lives ranging from 11 days for an HBCD mixture to 128, 92 and 72 days for α -, γ -, and β - HBCD, respectively, were reported. From these studies, half-life values of 2 to 6 months for aerobic soils and 11 days to 4 months for aerobic sediments were chosen. For aerobic soils these values represent the range reported for biodegradation half-lives of HBCD mixtures. For aerobic sediments these values represent the shortest half-life reported for an HBCD mixture and the longest half-life reported for a diastereomer (α - HBCD).

Table 2-2. HBCD Biodegradation Half-Lives Selected for Use in Risk Evaluation

Property	Value	Reference	Study Quality
Aerobic Biodegradation in Water	No biodegradation observed in 28-day closed-bottle test Organisation for Economic Co-operation and Development (OECD) Guideline 301D, EPA OTS 796.3200	(Wildlife Intl 1996) as cited in (EC 2008)	Medium
Aerobic Biodegradation in Sediment	Half-life: 128, 92, and 72 days for α -, γ -, and β -HBCD, respectively (estimated), based on a 44% decrease in total initial radioactivity in viable freshwater sediment of 14C-labeled HBCD (4.67 mg/kg dry weight) after 112 days; method based on OECD 308	(Davis et al. 2006)	High
	Half-life: 11 and 32 days (estimated) in viable sediment collected from Schuylkill River and Neshaminy creek, respectively, using nominal HBCD concentrations of 0.034–0.089 mg/kg; method based on OECD 308	(Davis et al. 2005)	High
Aerobic Biodegradation in Soil	Half-life: >120 days (estimated), based on a 10% decrease in total initial radioactivity in viable soil of 14C-labeled HBCD after 113 days; method based on OECD 307 using HBCD at 3.04 mg/kg dry weight	(Davis et al. 2006)	High
	Half-life: 63 days (estimated) in viable soil amended with activated sludge using a nominal HBCD concentration of 0.025 mg/kg dry weight; method based on OECD 307	(Davis et al. 2005)	High

Biodegradation half-lives for the water column and sediments are required as input to the PSC-VVWM model. The model is used to estimate water column and sediment concentrations for the Environmental Risk Characterization described in Section 4.1. EPA used the biodegradation half-life ranges as reported in or derived from the studies discussed in Sections 2.1.2 and 2.1.3 and as an alternative, the Office of Pesticide Programs approach to calculating the 90th percentile confidence bound on the mean biodegradation half-life value, and the *Standard Operating Procedure for Using the NAFTA Guidance to Calculate Representative Half-life Values and Characterizing Pesticide Degradation* ([U.S. EPA 2015b](#)) which provides tools to determine the appropriate kinetics and associated half-lives for biodegradation studies.

The 90th percentile confidence bound on the mean biodegradation half-life value is calculated according to the equation below:

Equation 1:

$$t_{\text{input}} = \bar{t}_{1/2} + [(t_{90,n-1}s) / n^{1/2}]$$

where,

t_{input} = half-life input value (time)

$\bar{t}_{1/2}$ = mean of sample half-lives (time)

s = sample standard deviation (time)

n = number of half-lives available (-)

$t_{90,n-1}$ = one-sided Student's t value at $\alpha = 0.1$ (i.e., 1.0-0.9) (-)

This equation does not calculate the 90th percentile of the distribution of half-life values.

The rate of transformation of organic chemicals in the environment is commonly described using first-order kinetics, often referred to as single first-order (SFO). The first-order representation is convenient because the rate is summarized with a single parameter (the rate constant, k), and the rate of transformation is independent of the initial concentration. The half-life, $t_{1/2} = \ln(2)/k$, indicates the time required to reduce the concentration by 50% from any concentration point in time. It is an intuitive way to express the rate of decline of a first-order degradation. In contrast, the DT50 is the time required for the concentration to decline to half of the initial value. For non-first-order decay, the time to reach half the concentration from any other concentration point on the curve will be different.

The VVWM-PSC model requires first-order inputs for the modeled chemical's transformation processes even though a chemical's transformations in aquatic systems often does not follow a single exponential decline pattern. For this reason, the NAFTA guidance introduces a "representative half-life (t_{rep})" to estimate an SFO half-life for model input from a degradation curve that does not follow the SFO equation. The procedure takes into consideration the frequent observation that chemicals can degrade fast initially and then slowly as time passes, much more so than a first-order representation would predict. The representative half-life considers both the initial and the slower portions of the decline curve and is not necessarily numerically similar to the value of the DT50.

Table 2-3. HBCD Biodegradation Half-lives (days) Reported and Representative Half-lives Calculated Using OPP/NAFTA Guidance

Reference	Medium	Reported	90 th Percentile Confidence Bound	OPP/NAFTA Guidance
(Davis et al. 2005)	Aerobic Sediment	11	112	6
(Davis et al. 2005)	Aerobic Sediment	32		8
(Davis et al. 2006)	Aerobic Sediment	128		100

The PestDF program calculates and selects the representative half-life value based on the NAFTA guidance. The tool considers three transformation models: SFO, double first-order in parallel (DFOP), and indeterminate order rate equation (IORE) and a set criteria for selecting parameters. Based on the number of fitted parameters, SFO is the simplest of the three models, while DFOP is the most complex.

OPP guidance also allows for a 3X factor to be used to account for uncertainty and variability where only 1 half-life value is available. In this evaluation the 3X factor was used with the longest reported half-life from Davis et al. ([2006](#)) to give a half-life of 384 days.

In order to demonstrate the effect of changes in benthic half-lives on estimated porewater, water column and sediment HBCD concentrations estimated by VVWM-PSC, a limited sensitivity analysis was conducted. All environmental parameters, loading and abiotic half-lives were held constant. Multiple runs of VVWM-PSC were executed varying only the benthic half-life using the values reported in Table 2-3 above. The results are shown in Table 2-4 below.

Table 2-4. Impact of the Use of the Range of Biodegradation Half-lives (days) Reported and Representative Half-lives Calculated Using OPP/NAFTA Guidance on PSC-VVWM Concentration Estimates^a

Benthic Half-life Days	Water Column Concentration 21 Day Average (µg/L)	Water Column Concentration 28 Day Average (µg/L)	Sediment Pore Water Concentration 28 Day Average (µg/L)	Total Benthic Concentration 28 Day Average (µg/kg)
6	19.9	29.3	3.91	15600
8	20.2	29.5	4.6	18400
11	20.5	29.9	5.63	22500
32	21.9	31.2	9.55	38200
100	23.3	32.6	13.5	54200
112	23.4	32.7	13.9	55400
128	23.5	32.8	14.2	56900
384	24.2	33.6	16.3	65200

^a Standard Operating Procedure for Using the NAFTA Guidance to Calculate Representative Half-life Values and Characterizing Pesticide Degradation ([U.S. EPA 2015b](#))

As can be seen from the results of the modeling, benthic half-lives over the ranges discussed in the final Risk Evaluation have a negligible effect on water column concentrations. Thus, the half-life chosen for use in PSC-VVWM will not generally result in changes in ecological Risk Quotients for a given scenario. In contrast, sediment pore water and total benthic concentrations increase approximately 4 to 5 times as benthic half-lives increase from six to 384 days. The impact of half-life on benthic Risk Quotients are further discussed in Section 4.1 Environmental Risk.

Bioconcentration/Bioaccumulation Factors

A range of bioconcentration/bioaccumulation values have been reported for HBCD and separately for the three stereoisomers. The range of reported values were measured in laboratory studies or estimated from field collected data. These studies are subject to several sources of variability including variability inherent in the methodology, interlaboratory variability and variability due to factors such as the test species used, test substance concentration, as well as temporal and spatial factors in collection of field samples. No single value is universally applicable as it is influenced by these variables and possibly others. However, taken as a whole, studies indicate HBCD is subject to bioconcentration, bioaccumulation and trophic magnification.

A field measured bioaccumulation factor (BAF) selected for use in the Risk Evaluation ([Wu et al. 2010](#)) was used as input to the estimation of highly exposed general population fish ingestion exposure discussed further in Section 2.4.3. Initially, EPA considered two BAF values, one higher and one lower. Both studies were rated high for data quality. The differences in reported BAFs could be due to a number of factors including the metabolic differences in the test species selected. The selection of the higher BAF as input to the estimation of general population fish ingestion exposure will result in higher fish tissue concentrations of HBCD and higher exposures to general population via fish ingestion. This will lead to estimates of higher risk for this population compared to using the lower BAF value. Due to the small number of field derived fish BAF studies found (2) it was not possible to assess the variability in field derived BAFs across field conditions, dissolved HBCD concentrations, species and trophic levels. In the studies EPA identified, the reported dissolved HBCD concentrations in Chinese water bodies were in the range of 0.04 to 0.06 ng/L. These are about an order of magnitude lower than the range of dissolved HBCD surface water concentrations reported in surface water monitoring studies. The range of HBCD surface water concentrations biota are assumed to be exposed to for the Risk Evaluation was determined using monitoring data and model estimates. After consideration of factors including the edibility and palatability of the species, an upper trophic level lipid normalized field measured BAF for the northern snakehead was selected for use as a surrogate species for the fish ingestion exposure assessment. The use of lipid normalized field measured BAF data for an upper trophic level species incorporates results of dietary exposure and biomagnification in the food web. However, the small number of BAF values, the limited number of species and field conditions add to uncertainty associated with the use of these BAFs in estimating human exposure to HBCD via fish ingestion.

For the purposes of the Risk Evaluation, lipid normalized bioaccumulation factors in whole fish consumed by humans, and bioconcentration factors in species in aquatic and terrestrial food webs were used. These values are converted to wet weight BAF values (BAF_{ww}) for use in dietary exposure calculations using the following formula:

$$\text{BAF}_{\text{ww}} = \text{BAF}_{\text{LW}} * \text{lipid fraction}$$

See Appendix C for underlying data and calculations of BAFs for HBCD.

Field-measured bioaccumulation factors for HBCD were preferentially used over bioconcentration factors for the Risk Evaluation. A BAF derived from data obtained from field-collected samples of tissue and water is the most direct measure of bioaccumulation. A field-measured BAF is determined from measured chemical concentrations in an aquatic organism and the ambient water collected from the same field location. Because the data are collected from a natural aquatic ecosystem, a field-measured BAF reflects an organism's exposure to a chemical through all relevant exposure routes (*e.g.*, water, sediment, diet). A field-measured BAF also reflects factors that influence the bioavailability and metabolism of a chemical that might occur in the aquatic organism or its food web. Therefore, field-measured BAFs are appropriate for all chemicals, regardless of the extent of chemical metabolism in biota ([U.S. EPA 2003](#)). Specifically, the field measured BAFs reported by ([Wu et al. 2010](#)), and ([He et al. 2013](#)) were reviewed. These studies scored high using data quality metrics for environmental fate studies. In addition, the studies reported BAF values in upper trophic level (*i.e.*, piscivorous fish). BAFs in organisms occupying higher trophic levels in food webs may better reflect exposure due to dietary uptake than organisms in lower trophic levels. Using data from ([Wu et al. 2010](#)), an upper trophic level lipid normalized BAF for total HBCDs of approximately 3,120,000 was calculated from the mean HBCD lipid normalized fish tissue concentration and the HBCD dissolved water concentration. Using data from ([He et al. 2013](#)), an upper trophic level lipid normalized BAF for total HBCDs of approximately 9,090,000 was calculated from the mean HBCD lipid normalized fish tissue concentration and the HBCD dissolved water concentration. It should be noted that in both the studies, sample sizes for fish were small ($n=6-15$) and variability in tissue concentrations for a single species of fish was as high as 3 times the mean value. While this variability leads to uncertainty in the use of the data, the preference for the use of upper trophic level field measured BAFs and lack of other similar studies was considered in the decision to use the study. The steady-state BCF values in rainbow trout edible portions ([Wildlife Intl LTD 2000](#)), as cited in ([ECHA 2008b](#)), were used to supplement the Risk Evaluation. A kinetic BCF value of 14,039 for the 0.18 $\mu\text{g/L}$ exposure concentration was calculated to address the possibility that steady state was not reached ([ECHA 2008b](#)). The study received a high confidence score based on evaluation metrics for fate studies.

Due to the small number of field derived fish BAF studies found (2) it was not possible to assess the variability in field derived BAFs. EPA did not have a sufficient number of bioaccumulation studies to follow the Office of Water methodology for deriving bioaccumulation factors intended to develop BAFs for setting national water quality criteria ([U.S. EPA 2000](#)). The methodology is generally used with large sets of BAF data for multiple trophic levels and species from studies reflecting a range of geochemical and biological conditions. However, using the approach for chemicals classified in the Office of Water methodology as nonionic organic chemicals with moderate to high hydrophobicity ($\log K_{\text{ow}} \geq 4$) and low metabolism to calculate baseline and national BAF values yielded upper trophic level (TL 4) BAF values approximately two times greater than the field measured values reported for northern snakehead ([Wu et al. 2010](#)). The differences are due, in part, to the differences between site specific and species-specific variables in the field study (*e.g.*, the particulate organic carbon levels and the lipid fraction in fish) which impact bioaccumulation factors and the default values for those variables used in the Office of Water methodology to derive the upper trophic level (TL 4) BAF.

EPA identified two BCF studies and two BAF studies on HBCD. BAF studies are preferred over BCF studies because they represent exposure of the organism to HBCD via all routes, including diet which is

important for a hydrophobic chemical such as HBCD. The BAF studies ([He et al. 2013](#)) reported data EPA used to calculate upper trophic level lipid normalized BAFs for several trophic levels, however, the species reported were native to China. With limited available data EPA chose to use the upper trophic level species (northern snakehead) ([Wu et al. 2010](#)) as a surrogate for an upper trophic level species native fish and assumed its lipid normalized BAF was equivalent to that of an upper trophic level native fish. Because a single BAF from a single species is used, impacts of factors including lipid content, organism size, spatial and temporal variability in exposure concentrations, sample size, trophic position and differences in food webs and ecosystems cannot be considered. The absence of this information creates uncertainty in how representative the BAF may be and if its use will under or overpredict fish tissue concentrations and human exposure via fish ingestion.

Table 2-5. HBCD Bioaccumulation and Bioconcentration Factors Reviewed for Use in the Risk Evaluation

Property	Value	Reference	Study Quality
Field Measured Bioaccumulation Factor (BAF)	Upper trophic level lipid normalized BAF for total HBCDs of approximately 3,120,000 calculated from the mean HBCD lipid normalized fish tissue concentration and the HBCD dissolved water concentration. —northern snakehead Wet weight BAF 46,488	(Wu et al. 2010)	High
	Upper trophic level lipid normalized BAF for total HBCDs of approximately 9,090,000 calculated from the mean HBCD lipid normalized fish tissue concentration and the HBCD dissolved water concentration. —catfish Wet weight BAF 290,880	(He et al. 2013)	High
Bioconcentration Factor (BCF)	fathead minnow 18,100 (whole body)	(Veith et al. 1979)	High
	rainbow trout 4650 – 6531 (edible portion) 14039 (kinetic BCF 0.18 µg/L exposure concentration)	(Wildlife Intl LTD 2000) as cited in (ECHA 2008b)	High

HBCD in Microplastics

HBCD incorporated into EPS and XPS may enter air, water and soil environments as particulates as a result of its processing, use, and demolition and disposal of building material containing EPS and XPS insulation. (See Section 2.2 Releases to the Environment). HBCD containing particulates may be produced during insulation board cutting and building demolition. HBCD containing insulation may generate particles from physical abrasion and weathering. These particles may include a size range similar to that of microplastics (*i.e.*, items < 5 mm diameter) ([Lambert et al., 2014](#)). In the aquatic environment, the ingestion of plastics by biota establishes a potential exposure pathway for chemical contaminants that may be incorporated into the plastics during manufacture or metals, and persistent, bioaccumulative, and toxic contaminants that may be sorbed from the water column to plastic. ([Engler 2012](#)).

Scientific research including field studies (*e.g.*, [Yamashita et al. 2011](#); [Lavers et al., 2014](#); [Rochman et al., 2014](#)) and laboratory studies (*e.g.*, [Teuten et al., 2009](#); [Besseling et al., 2013](#); [Rochman et al., 2013](#)) suggests that several groups of aquatic or aquatic-dependent organisms (invertebrates, fish, and birds) can accumulate chemicals associated with plastics once ingested. Experimental studies investigating the effects of chemicals associated with plastics on invertebrates and fish indicate that there are negative sublethal effects on these organisms from chemicals associated with plastics as well as the plastic itself (*e.g.*, [Rochman et al., 2013, 2014](#); [Avio et al., 2015](#)). However, some bioaccumulation modeling

approaches attempting to simulate environmentally realistic scenarios of exposure provide indirect evidence that the role of plastics in contributing to body burdens and effects of chemical pollutants may be relatively small compared with other exposure pathways, such as direct chemical exposure via water, sediment, or ingestion of contaminated prey ([Koelmans et al., 2016](#); [Bakir et al., 2016](#); [Ziccardi et al., 2016](#)).

EPS particles in the microplastics size range (<5 mm) have been implicated as potential vectors for HBCD in the marine environment. Such particles can be generated when larger EPS objects in the ocean are subjected to biodegradation, ultraviolet radiation, temperature, and the mechanical forces associated with wave action ([Rani et al. 2017](#)). In one study, EPS buoys were identified as the source of elevated HBCD concentrations in sediments off the coast of South Korea ([Al-Odaini et al. 2015](#)). Further investigation found that mussels inhabiting EPS substrates in the same region had higher HBCD body burdens than those inhabiting high-density polyethylene, metal, and rock ([Jang et al. 2016](#)). These findings appear to indicate a potential exposure pathway for ecological and human receptors due to bioaccumulation of HBCD from microplastics. However, it is not currently feasible to quantify the exposure of upper trophic level organisms to microplastic-associated HBCD. This is generally true of all microplastic-associated pollutants due to the large number of variables controlling their uptake and potential bioaccumulation/biomagnification ([Au et al., 2017](#); [Ziccardi et al. 2016](#)). In the specific case of HBCD, there is currently not sufficient data on the distribution of the chemical in microplastics across geographic regions ([Jang et al. 2017](#)), nor its ability to leach from ingested microplastic particles and become available for distribution, metabolism, and excretion ([Lohmann et al. 2017](#)). If microplastic-associated HBCD is readily bioavailable, its behavior may be similar to that of pure particulate HBCD. However, it is more likely that association with microplastics has complex and opposing influences on HBCD exposure. While they can serve as a vector, microplastics may also reduce bioavailability and potentially scavenge free HBCD. In the absence of data needed to parameterize a model, this complexity cannot currently be resolved.

2.2 Releases to the Environment

EPA assessed environmental releases of HBCD for the following HBCD exposure scenarios:

- 1) Repackaging of Import Containers
- 2) Compounding of Polystyrene Resin to Produce XPS Masterbatch
- 3) Processing to Produce XPS Foam using XPS Masterbatch
- 4) Processing of HBCD to Produce XPS Foam
- 5) Processing to Produce EPS Foam from Imported EPS Resin Beads
- 6) Processing to Produce SIPs and Automobile Replacement Parts from XPS/EPS Foam
- 7) Use: Installation of Automobile Replacement Parts
- 8) Use: Installation of XPS/EPS Foam Insulation in Residential, Public and Commercial Buildings, and Other Structures
- 9) Demolition and Disposal of XPS/EPS Foam Insulation Products in Residential, Public and Commercial Buildings, and Other Structures
- 10) Recycling of EPS Foam and Reuse of XPS foam
- 11) Formulation of Flux/Solder Pastes
- 12) Use of Flux/Solder Pastes
- 13) Recycling of Electronics Waste (E-Waste) Containing HIPS

As discussed in Section 1.2.8, HBCD is no longer used to manufacture, process, or distribute four minor-use products or articles: textiles, HIPS in electronics, adhesives, and coatings. The four minor-use products and articles are expected to be currently already installed or in service. The processing of these

products during disposal at landfills and waste transfer stations may result in fugitive air releases of dust containing HBCD. These releases are not quantified in this section. EPA believes exposures to general population and environmental receptors are accounted for in the assessment of background exposure which is discussed in Section 2.4.2 for general population and Section 2.3.3.1 for terrestrial receptors.

Components of the Environmental Release Assessment

The environmental release assessment of each exposure scenario is comprised of the following components:

1. **Process Description:** A description of the exposure scenario, including the role of the chemical in the use; process vessels, equipment, and tools used during the exposure scenario; and descriptions of the worker activities, including an assessment for potential points of worker exposure and environmental releases.
2. **Facility Estimates / Processing or Use Volume and Number of Sites:** An estimate of the quantity of HBCD imported, processed, or otherwise used for each exposure scenario. An estimate of the number of sites that use the chemical for the given exposure scenario.
3. **Environmental Releases:** Estimates of chemical released into the environment (air, surface water, land) and wastes disposed to treatment methods (incinerators, wastewater treatment plants).

2.2.1 Release Assessment Approach and Methodology

Process Description

EPA performed a literature search to find descriptions of processes involved in each exposure scenario to identify worker activities that could potentially result in releases to the environment. Where process descriptions were unclear or not available, EPA referenced relevant emission scenario documents (ESDs) and generic scenarios (GSs), specifically the 2009 OECD ESD on Plastic Additives, the 2014 Draft OECD ESD on Use of Additives in Plastics Compounding, and the 2010 OECD ESD on Chemicals Used in the Electronics Industry. The process description for each exposure scenario will be discussed in each section.

Processing or Use Volume and Number of Sites

As indicated in Section 1.2.2 and 1.2.3, EPA has determined that the import of HBCD constitutes an intended, known and reasonably foreseen activity. The companies identified by the 2016 CDR as importers of HBCD have ceased importing, processing and using HBCD. The possibility exists that small firms could import quantities of up to 100,000 lbs/year per site without reporting to CDR. For the purpose of this Risk Evaluation, EPA used the CDR reporting threshold for small manufacturers (importers) of 100,000 pounds per year as the volume of HBCD imported by a possible unidentified site. EPA believes this volume is not unreasonable considering the recent relatively high volumes of HBCD manufactured / imported, processed and used through 2017 for XPS/EPS foam as shown in Table 1-2 and Table 1-4. EPA does note, however, that 100,000 pounds per year is an upper bound for the import volume for the unknown site, otherwise, the importer would be out of compliance with CDR reporting requirements. The lifecycle of the imported HBCD and more specifically the percentage of the volume used for each of the exposure scenarios is uncertain, and therefore, EPA uses the volume basis of 100,000 pounds per site per year to estimate environmental releases and exposures of each of the following exposure scenarios that entail the processing of HBCD for products and formulations containing HBCD:

- Repackaging of Import Containers
- Compounding of Polystyrene Resin to Produce XPS Masterbatch

- Processing to Produce XPS Foam using XPS Masterbatch
- Processing of HBCD to Produce XPS Foam
- Processing to Produce EPS Foam from Imported EPS Resin Beads
- Processing to Produce SIPs and Automobile Replacement Parts from XPS/EPS Foam (the processing volume for each exposure scenario is 100,000 pounds/year)

The import volume of 100,000 pounds per year is also used for assessing releases, number of sites, and exposures for the following exposure scenarios and will be further described in Sections 2.2.8 and 2.2.9, respectively:

- Use: Installation of Automobile Replacement Parts
- Use: Installation of XPS/EPS Foam Insulation in Residential, Public and Commercial Buildings, and Other Structures

EPA performed a sensitivity analysis for selected exposure scenarios using import volumes of 50,000 lbs/yr-site and 25,000 lbs/yr-site to examine the effect of process volume on environmental releases and resulting general population and environmental exposures. This is discussed in Section 2.2.15.

Environmental Release Assessment

EPA assessed, where applicable, releases to fugitive or stack air, discharges to on-site wastewater treatment (WWT), Publicly Owned Treatment Works (POTWs), or surface water, disposal to landfill, and treatment via incineration. EPA refers to these as methods of release, disposal, treatment, or discharge in the remainder of this section. All releases assessed are of solid HBCD or solid mixtures containing HBCD.

EPA assessed releases to landfill for Repackaging of Import Containers, Processing to Produce EPS Foam from Imported EPS Resin Beads, Processing: Recycling of EPS Foam and Reuse of XPS Foam, Processing to Produce SIPs and Automobile Replacement Parts from XPS/EPS Foam, and Use: Installation of XPS/EPS Foam Insulation in Residential, Public, and Commercial Buildings, and Other Structures in accordance with the 2009 OECD ESD on Plastic Additives. EPA assessed releases to landfill for Demolition and Disposal in accordance with data from ([Townsend et al. 2019](#); [U.S. EPA 2018](#); [TCEQ 2017](#)) and for Use of Flux/Solder Pastes in accordance with the 2010 OECD ESD on Chemicals Used in the Electronics Industry. The landfill types are not specified in these sources. As discussed in Section 1.4.2.2, EPA is not evaluating releases to RCRA Subtitle C hazardous waste landfills and RCRA Subtitle D municipal solid waste landfills (MWSLFs). Hazardous waste and municipal waste landfill design and management controls such as coverings, liners, and leachate collection and treatment are expected to adequately mitigate HBCD exposure, therefore, releases were not evaluated. HBCD is not designated as a RCRA hazardous waste because it is not specifically listed as a known hazardous waste and does not exhibit the characteristics of a hazardous waste (ignitability, corrosivity, reactivity or toxicity) (40 CFR 261). HBCD waste could be sent to industrial non-hazardous landfills, which are described here: <https://www.epa.gov/landfills/industrial-and-construction-and-demolition-cd-landfills>. Therefore, EPA assessed releases to these types of landfills.

EPA gathered and evaluated environmental release information according to the process described in the *Application of Systematic Review in TSCA Risk Evaluations* ([U.S. EPA 2018b](#)). The key data sources resulting from this process that were used to assess releases include TRI data, the European Union Risk Assessment Report (EURAR), and ([U.S. EPA 2008b](#)). The TRI data has an overall confidence rating of medium. The EURAR and ([U.S. EPA 2008b](#)) have overall confidence ratings of high.

Where available, EPA used 2017 TRI data to provide a basis for estimating releases. Facilities are only required to report to TRI if the facility has 10 or more full-time employee equivalents, is included in an applicable NAICS code, and manufactures, processes, or otherwise uses the chemical in quantities greater than a certain threshold in a given year (100-pound threshold for HBCD). Due to these limitations, some sites that use HBCD may not report to TRI and are not included in these datasets. EPA did not use some of the TRI data based on additional information gathered about current uses and reported releases. Specifically, EPA did not use the 2017 releases reported by Flame Control Coatings, LLC. The company indicated that they have ceased the use of HBCD in coatings.

TRI reporting by subject facilities is required by law to provide information on releases and other waste management activities of Emergency Planning and Community Right-to-Know Act (EPCRA) Section 313 chemicals (*i.e.*, TRI chemicals) to the public for informed decision making and to EPA to assist the Agency in determining the need for future regulations. Section 313 of EPCRA and Section 6607 of the Pollution Prevention Act (PPA) require certain facilities to report release and other waste management quantities of TRI-listed chemicals annually when a reporting threshold is triggered, but these statutes do not impose any monitoring burden for determining the quantities.

TRI data are self-reported by the subject facility where some facilities are required to measure or monitor emissions or other waste management quantities due to regulations unrelated to the TRI program, or due to company policies. These existing, readily available data are often used by facilities for TRI reporting purposes. When measured (*e.g.*, monitoring) data are not “readily available,” or are known to be non-representative for TRI reporting purposes, the TRI regulations require that facilities determine release and other waste management quantities of TRI-listed chemicals by making “reasonable estimates.” Such reasonable estimates include a variety of different approaches ranging from published or site-specific emission factors (*e.g.*, AP-42), mass balance calculations, or other engineering estimation methods or best engineering judgment. TRI reports are then submitted directly to EPA on an annual basis and must be certified by a facility’s senior management official that the quantities reported to TRI are reasonable estimates as required by law.

Where releases are possible, but TRI data were not available, releases were mostly estimated using release data from the European Union Risk Assessment Report (EURAR). EPA rated the release data from the EURAR an overall confidence rating of High during the systematic review process. This rating takes into account the reliability of the data (EPA considers the European Chemicals Agency [ECHA] to be a reliable source), the representativeness of the data, the accessibility / clarity of the data, and the variability and uncertainty of the data.

Where the above data were not available, EPA used relevant OECD Emission Scenario Documents (ESDs) or EPA Generic Scenarios (GSs from the 2009 OECD ESD on Plastic Additives, the 2018 Draft GS on the Application of Spray Polyurethane Foam, and the 2010 OECD ESD on Chemicals Used in the Electronics Industry). ESDs and GSs are standard sources used by EPA/OPPT for engineering assessments. These documents provide information on particular processes, including release sources, emission factors, and method of release, disposal, treatment, or discharge.¹³ EPA attempts to address variability in releases estimated with EURAR, OECD ESD, or EPA GS data by estimating ranges of emission factors and release days, as further described below.

¹³ Additional information on OECD ESDs can be found at: <http://www.oecd.org/chemicalsafety/risk-assessment/introductiontoemissionscenario documents.htm>. Additional information on EPA GSs can be found at: <https://www.epa.gov/tsca-screening-tools/chemsteer-chemical-screening-tool-exposures-and-environmental-releases>.

Specifically, for each exposure scenario, EPA estimated daily and annual quantities of HBCD released, where applicable using the following parameters:

- The annual importation, processing, or use volume per site.
- The number of importation, processing, or use sites.
- The emission factors for releases of HBCD.
- The number of days of HBCD releases.

The general approach for determining annual importation, processing, or use volume and the associated number of sites for each exposure scenario is discussed above.

An emission factor is the fraction of material emitted or released per unit volume (*i.e.*, kg released/kg throughput) during a specific activity or exposure scenario (*e.g.*, import, processing, or use). EPA determined emission factors either from EURAR data or from ESDs and GSs. Where available, EPA used EURAR release data, which is available as annual site-specific HBCD release quantities. The associated HBCD processing volumes at these sites were not provided in the EURAR. The EURAR only provided the combined HBCD processing volume for all the sites for which release data was provided. EPA could not calculate site-specific emission factors due to the lack of site-specific HBCD processing volumes. Using EURAR data, EPA calculated overall emission factors for an exposure scenario by dividing the total amount of HBCD released for all sites by the total HBCD processing volume for all the sites. For the purpose of this Risk Evaluation, EPA refers to these emission factors as average emission factors. In some cases, the EURAR provided what they call “worst-case” emission factors, described as being derived from the site with the highest release estimates. In these cases, EPA used these “worst-case” emission factors as they were reported by the EURAR because EPA could not calculate them without the site-specific HBCD processing volumes. EPA used both the average and “worst-case” emission factors from the EURAR to provide a range of emission factors and release quantities.

Where EURAR data were not available, EPA used emission factors that were reported in OECD ESDs or EPA GSs. Where there were multiple approaches for estimating emission factors in the ESDs or GSs, such as from assuming different types of containers or vessels are being cleaned, EPA assessed a range of emission factors. The information provided in ESDs and GSs generally do not have statistical characterization of the emission factors.

EPA calculated a range of annual release quantities for each exposure scenario by multiplying the range of emission factors and the annual throughput of HBCD at a site. EPA calculated daily release quantities by dividing the range of annual release quantities by the estimated number of release days. For most exposure scenarios, EPA estimated a range of release days to generate a range of daily release estimates. In general, EPA used the lowest estimated value and the highest estimated value of number of release days to develop a range. EPA does not know the statistical characterization (*e.g.*, mean, maximum, 95th percentile) of these ranges because EPA did not find a comprehensive dataset of release days from which these statistics could be calculated. In order to develop estimates of release days in support of determining these ranges, EPA used one or a combination of the following approaches, in order of priority:

- Where available, EPA used the number of release days reported in the EURAR for the sites with HBCD release days. The number of release days is based on industry data for sites that perform the same operations as those being assessed.

- Where data on release days reported by industry was not available, EPA estimated the number of release days using ESDs or GSs.
- Where data were limited using the above two approaches, EPA estimated the number of release days using the European Communities Technical Guidance Document ([ECB 2003](#)). This technical guidance document contains methodology for estimating the number of release days using the industrial category (*i.e.*, polymer industry, electronics), use category/function within the industry (*i.e.*, flame retardant), lifecycle stage (*i.e.*, manufacturing, formulation, or use), and the production volume (tons/yr) of the chemical of interest (*i.e.*, HBCD importation, processing, or use volume). EPA estimated the number of release days using the most applicable industry category, which was the polymer processing industry in most, but not all, exposure scenarios. EPA then selected the most applicable use category/function within the industry for the exposure scenario and used the assessed HBCD processing or use volume solely to determine number of release days. In some cases, where the above two approaches could not be used, EPA developed ranges of release days using this method by determining the lowest and highest number of potential release days by varying the function and HBCD processing or use volume within an industry category.

Using the HBCD volume, number of sites, a range of emission factors, and a range of release days, EPA calculated a range of daily releases per site for each exposure scenario using Equation 2-1:

$$\text{Equation 2-1.} \quad R = [(V \div N_s) \times f] \div N_d$$

Where:

- R = the amount of HBCD released per day to water, air, or landfill from a site (kg per day per site)
- V = annual U.S. HBCD importation, processing, or use volume (kg per yr)
- N_s = the number of U.S. importation, processing, or use sites (sites)
- f = emission factor for release of HBCD to water, air, or landfill from a process (kg of HBCD released to water or air or landfill per kg of HBCD imported, processed or used)
- N_d = the number of release days per year from a site (days)

Specific details related to the use of release data or models and the calculation of ranges of emission factors and release days for each exposure scenario are further described below.

Releases to air were assessed as hourly rates to enable the modeling of these releases for the assessment of general population exposure. EPA assumes the industrial processes that are associated with the exposure scenario are operated at least 8 hours/day. Furthermore, air release sources such as unloading and addition into processing equipment may occur throughout a day, so EPA assumes air releases may occur over the entire operation time of 8 hours/day. This may result in underestimation or overestimation of the hourly rate of releases to air.

2.2.2 Repackaging of Import Containers

In the United States, HBCD was manufactured in three grades: fine powder, standard grade powder, and granules ([ECHA 2008b](#)). HBCD particle size distribution in HBCD products varied depending on the producer and is summarized as follows ([NICNAS 2012b](#); [ECHA 2008b](#)):

- For fine grade powder, the mean particle size was 2 to 19 μm .
- For standard grade powder, the mean particle size was 20 to 150 μm .
- For granules, the mean particle size was 560 to 2,400 μm .

HBCD was manufactured at a purity of 90% to 100% HBCD ([NICNAS 2012b](#); [KemI 2009](#)). EPA expects that HBCD would also be imported into the United States at this purity in standard grade powder or granular form as specified above. HBCD may also be imported in EPS resin beads at a concentration of 0.7% or in XPS masterbatch at a concentration of 40-70% ([NICNAS 2012b](#); [ECHA 2008b](#)). Micronized (fine grade) powder is typically used in textile and adhesive formulations ([NICNAS 2012b](#); [ECHA 2008b](#)), which EPA has determined are no longer exposure scenarios in the United States and are not assessed in this Risk Evaluation.

EPA has not identified information on the importation and repackaging of HBCD within the United States. However, EPA expects that importation activities described in risk assessments performed by other countries are similar to those performed in the United States.

The Australian Priority Existing Chemical Assessment Report on HBCD indicates that powder or granular HBCD was imported into Australia in 25-kg polylined paper bags and states that this took place prior to 2010. The report also indicates that EPS resin beads containing HBCD were imported in 25-kg polylined paper bags and 700-kg lined meshed plastic bags ([NICNAS 2012b](#)). The European Union Risk Assessment Report (EURAR) on HBCD indicates that HBCD powder was packaged in 850-kg boxes ([ECHA 2008b](#)). Based on information from the Australian Report and the EURAR, EPA evaluated releases from repackaging assuming HBCD may be imported in 700-kg bags or 850-kg boxes, which may be repackaged into differently sized containers, depending on customer demand, and quality control (QC) samples may be taken for analyses.

Once imported into the United States, HBCD powder is used to produce XPS masterbatch or to directly produce XPS foam.¹⁴ Imported EPS resin beads are used to produce EPS foam. Repackaging of import containers occurs on an as-needed basis, driven by customer demand. Exposures and releases are not expected if repackaging of HBCD into smaller containers does not occur.

Environmental Release Assessment Methodology

Facility Estimates

As discussed in Section 2.2.1, EPA estimates environmental releases based on a processing volume of 100,000 pounds per site per year and estimates a single unidentified site for this exposure scenario.

Release Sources

Based on the process description, EPA infers that releases may occur from dust generation during the transfer of HBCD powder, granules, or masterbatch from import containers into new containers and from residual HBCD in the emptied import containers that are disposed of. NICNAS ([2012b](#)) includes information from one company that repackaged HBCD in an open or semi-closed process. EPA does not know the prevalence of closed repackaging systems in the United States and estimates dust releases as described below. Repackaging of HBCD into smaller containers may involve the use of equipment, such as hoppers. However, EPA believes that the cleaning of such equipment would be infrequent (*e.g.*, done for maintenance purposes only) and there would be minimal residual material in the equipment prior to cleaning because such equipment would be designed for gravity flow of solid particulates. Therefore, EPA did not assess releases from equipment cleaning in this exposure scenario. NICNAS ([2012b](#)) and

¹⁴ In this Risk Evaluation, EPA refers to EPS and XPS foam articles, including insulation, as EPS and XPS foam. The Problem Formulation for Cyclic Aliphatic Bromides Cluster (HBCD) prepared prior to this Risk Evaluation often referred to these foam articles simply as EPS and XPS.

Environment Canada ([EC/HC 2011](#)) did not assess release from equipment cleaning. The EURAR ([ECHA 2008b](#)) did not assess repackaging as an exposure scenario.

Emission Factors

EPA used the emission factors given in the 2009 OECD ESD on Plastic Additives ([OECD 2009](#)), specifically for flame retardants used in activities expected to occur during this exposure scenario, as described below. The 2009 OECD ESD on Plastics Additives estimates releases by applying emission factors to the throughput of the chemical of interest, in this case HBCD ([OECD 2009](#)). For dust releases, the OECD ESD estimates an emission factor of up to 0.5% for fine particles (<40 µm) and 0.1% for coarse particles (>40 µm). EPA uses this range of emission factors to estimate dust releases. Per the OECD ESD, the initial release is to air, with particles eventually settling and being disposed of as solid waste or discharged in wastewater from cleaning of surfaces onto which the particles have settled ([OECD 2009](#)). The specific method of release, disposal, treatment, or discharge is dependent on site-specific factors, such as any pollution controls that are implemented at that site, as well as other factors such as the equipment used and size of the importation site. EPA does not know the prevalence of dust capture and control technologies at importation sites in the United States. Depending on site-specific conditions, HBCD may be released to stack air or fugitive air, discharged to POTW or onsite WWT, disposed of to landfill, or treated via incineration ([OECD 2009](#)).

For container residue, the OECD ESD on Plastics Additives uses an emission factor of 1%. The OECD ESD indicates that containers are likely to be disposed of to landfill. EPA uses this emission factor to estimate release of solid HBCD from container disposal to landfill. Although there is no statistical characterization of this emission factor, EPA believes the 1% emission factor is in the upper end of the distribution based on EPA's experience. No other release sources are identified in the OECD ESD or expected by EPA, based on the process description, for this exposure scenario.

A summary of the release sources assessed by EPA is presented in Table 2-6.

Table 2-6. Summary of HBCD Release Sources During Repackaging of Import Containers

Release Source	Emission Factor used in this Risk Evaluation	Method of Release, Disposal, Treatment, or Discharge Assessed in this Risk Evaluation	Basis or Source
Dust generation from unloading solid standard grade powder from import containers into new containers	0.001-0.005 kg HBCD released/kg HBCD handled	Uncertain: Stack air, or Fugitive Air, POTW, Onsite WWT, Landfill, or Incineration	(OECD 2009)
Disposal of import containers (bags) containing solid HBCD	0.01 kg HBCD released/kg HBCD in containers	100% Landfill	(OECD 2009)

Number of Release Days

EPA estimated the number of release days based on information in the European Communities Technical Guidance Document ([ECB 2003](#)). EPA estimated the lowest and highest possible number of release days per year using data from the basic chemicals industry category in the European Communities Technical Guidance Document. EPA calculates a lower value of 29 days/year and an upper value of 300 days/year. This range of number of release days per year seems reasonable in

comparison to information from the Australian risk assessment ([NICNAS 2012b](#)) which indicates that one company in Australia infrequently repackaged HBCD imported in 25-kg bags into 15-kg bags at a rate of one metric ton of HBCD repackaged every three months over a period of five days per repackaging campaign. Using this repackaging rate of one metric ton (2,205 pounds) over five days and EPA's production volume of 100,000 pounds HBCD/year, EPA calculates a United States repackaging frequency of approximately 227 days/year. The estimate of 227 day/year falls within the range of 29 to 300 days/year. Based on these data, EPA estimated a range of release days for this exposure scenario of 29 to 300 days/year.

The data sources used to estimate releases in this section are listed in Table 2-7 with the data quality score. See Appendix D for more details about data source evaluation.

Table 2-7. Repackaging of Import Containers – HBCD Release Data Source Evaluation

Source Reference	Data Type	Value	Overall Confidence Rating of Data
(ECB 2003)	Days of Release	29 to 300 days/year for all releases	Medium

Environmental Release Assessment Results

The variables used for calculating releases with Equation 2-1 are summarized in Table 2-8.

Table 2-8. Input Variables to Equation 2-1 for Repackaging of HBCD Import Containers

Input Variable				
V (of HBCD)	Ns (sites)	f (kg HBCD released/kg HBCD imported)		Na (days/yr)
		Lower value of emission factors	Upper value of emission factors	
100,000 pounds/year = 45,359 kg/year ^a	1	0.001 to Stack air, Fugitive Air, POTW, Onsite WWT, Landfill, and/or Incineration 0.01 to Landfill	0.005 to Stack air, Fugitive Air, POTW, Onsite WWT, Landfill, and/or Incineration 0.01 to Landfill	29-300

^a CDR reporting threshold for small manufacturers ([U.S. EPA 2016b](#))

The results of these calculations for all methods of release, disposal, treatment, or discharge are summarized in Table 2-9. EPA presents a range of release estimates from the 2009 OECD ESD on Plastic Additives ([OECD 2009](#)), varied over a range of release days, as previously discussed. The repackaging of import containers may result in releases to air, discharge to POTW, and/or disposal to landfill. Overall, disposal to landfill exceeds air releases and wastewater discharges, largely due to the disposal of the bags in which HBCD is imported.

Strengths, Limitations, and Confidence in Assessment Results

EPA has medium confidence in the assessed range of daily release rates presented above. EPA considered the quality of the data, the assessment approach, and uncertainties in assessment results to determine the level of confidence.

The result of EPA's systematic review is data pertaining to the number of release days with an overall confidence rating of medium; the quality of the emission factor data was not evaluated because this data was obtained from an OECD ESD.

The strength of the assessment approach is the estimation of HBCD emission factors and number of release days as ranges of values to account for variability in the values of these two parameters that EPA obtained. Furthermore, the strength of the assessment approach is the estimation of the daily release of HBCD per site as a range of values which encompasses the range of emission factors and the number of release days that EPA obtained.

There is uncertainty about the extent to which the emission factor data and the data on number of days of release per year are applicable to the HBCD processing that would occur in the U.S. Based on the strength and uncertainty of the assessment, EPA has medium confidence in the assessment results.

Table 2-9. Summary of HBCD Releases from Repackaging of Import Containers

Release Source	Method of Release, Disposal, Treatment, or Discharge (a)	Releases calculated from lower value of range of emission factors ^b				Releases calculated from upper value of range of emission factors ^b				Number of Sites	Hours of Release per Day (hr/day)
		Total Annual Release for All Sites (kg/yr)	Annual Release per Site (kg/site-yr)	Daily Release (kg/site-day)		Total Annual Release for All Sites (kg/yr)	Annual Release Per Site (kg/site-yr)	Daily Release (kg/site-day)			
				Number of release days: 29 days/year	Number of release days: 300 days/year			Number of release days: 29 days/year	Number of release days: 300 days/year		
Dust release during unloading of HBCD	May go to one or more: stack air, fugitive air, on-site WWT, POTW, landfill, or incineration	45.4	45.4	1.56	0.15	227	227	7.82	0.756	1	8 hours/day
Disposal of transport bags containing solid HBCD residual	Landfill	454	454	15.64	1.51	454	454	15.64	1.51	1	8 hours/day

^a The method of release, disposal, treatment, or discharge may include some or all of those listed depending on site-specific conditions, including type of equipment use, size of the site, and waste handling practices, including any pollution controls used.

^b Release estimates are quantities of HBCD. The physical form of these releases is solid HBCD.

2.2.3 Compounding of Polystyrene Resin to Produce XPS Masterbatch

Imported HBCD powder or granules may be compounded into an XPS masterbatch prior to being sold to XPS foam manufacturers, who then convert the XPS masterbatch into XPS foam. Imported HBCD powder may be sent to XPS masterbatch compounding sites in 25-kg bags or supersacks ([ECHA 2008b](#)). HBCD is unloaded into a hopper and pre-blended with polystyrene in the hopper or else transferred directly to mixing equipment. From the mixer, the mixture is then fed into an extruder where it is extruded through a die to produce pellets or granules ([NICNAS 2012b](#)). The pellets or granules are air-cooled or cooled in a water bath, dried, and then packaged ([ECHA 2008b](#)). The HBCD content in the XPS masterbatch is up to 40-70% of the pellets ([NICNAS 2012b](#); [ECHA 2008b](#)). The packaged XPS masterbatch is then sent to converting sites, where it is turned into XPS foam.

Environmental Release Assessment Methodology

Facility Estimates

As discussed in Section 2.2.1, EPA estimates environmental releases based on a processing volume of 100,000 pounds per site per year and estimates a single unidentified site for this exposure scenario.

Release Sources

Based on the process description, EPA infers that releases may occur from: dust generation during unloading of the HBCD powder or granules from the bags in which they were received and during the compounding process; disposal of the bags in which the HBCD powder is received; and cleaning of process equipment.

Emission Factors

EPA estimated emission factors based on site-specific release data reported in the EURAR ([ECHA 2008b](#)). The EURAR identified 14 sites in the EU that compound polystyrene to produce XPS masterbatch that is flame retarded with HBCD ([ECHA 2008b](#)). Site-specific annual release rates of solid HBCD were reported for three of the sites, indicating releases to wastewater and air, which are summarized in Table 2-10. To maintain confidentiality, the EURAR did not provide site-specific HBCD processing volumes with which site-specific emission factors could be calculated. However, the EURAR provided the total HBCD processing volume for the three sites for which release data is available. EPA calculated overall average emission factors to air and water by dividing the total HBCD release to air or water from all three sites by the total HBCD processing volume for the three sites. EPA calculated overall average emission factors of 3.22×10^{-5} kg HBCD discharged/kg HBCD processed to water and 6.12×10^{-6} kg HBCD released/kg HBCD processed to air.

The EURAR also provided emission factors of 7.42×10^{-5} kg HBCD discharged/kg HBCD processed to water and 7.31×10^{-6} kg HBCD released/kg HBCD processed to air, indicating that these are the “worst-case” factors that the EURAR calculated using the site-specific release and HBCD processing volume data from the three sites. Because site-specific HBCD processing volume data were not provided, EPA could not calculate these “worst-case” emission factors. EPA used both the “worst-case” emission factors as they were reported in the EURAR and the average emission factors calculated by EPA to provide a range of release estimates during this exposure scenario.

The EURAR indicates that wastewater discharges are to wastewater treatment. EPA did not identify information about the prevalence of wastewater treatment at these types of processing sites in the United States and hence assumed that water discharges from this exposure scenario can be to surface water, POTW, and/or onsite wastewater treatment. The EURAR does not specify if the reported air releases for

these three sites are to stack or fugitive air. Sites may implement dust capture technologies that may determine whether this release is to stack or fugitive air. EPA did not identify information on the prevalence of dust capture technologies at processing sites in the United States and assesses this release may include stack air and/or fugitive air.

Table 2-10. HBCD Release Data Reported in the EURAR for XPS Masterbatch Production

Site-Specific Release Data			Process Volume
Site Identity	Release to Water	Release to Air	
	kg/yr	kg/yr	
Site 1	0.12	2.6	The EURAR identifies a total of 1,160 metric tons of HBCD is processed at the 3 sites with site-specific release data.
Site 2	0.27	1.2	
Site 3	37	3.3	

Number of Release Days

EPA estimated the number of release days based on information reported in the European Communities Technical Guidance Document ([ECB 2003](#)) because the actual number of release days associated with the site-specific annual release rates discussed above is not reported in the EURAR. Instead, the number of release days reported in the EURAR are defaults recommended in the European Communities Technical Guidance Document ([ECB 2003](#)). The Environment Canada assessment also estimated emission days for compounding with the same methodology ([EC/HC 2011](#)). HBCD compounding occurs once per day at a site for the production of polystyrene masterbatch according to the Australian risk assessment. EPA did not use this information because the HBCD processing volume is not reported. Using the European Communities Technical Guidance Document ([ECB 2003](#)) and the defaults for formulation within the polymer industry, EPA estimated 60 emission days/year for an HBCD processing volume of 100,000 pounds (45.3 metric tons). EPA used the 2014 Draft OECD ESD on Use of Additives in the Plastics Compounding to estimate the number of release days during this exposure scenario. The OECD ESD indicates that, based on EPA new chemical submissions from industry, that the lowest number of operating days reported was 10 days/year ([U.S. EPA 2014a](#)). Based on these data, EPA estimated a range of release days of 10 to 60 days/year.

The data sources used to estimate releases in this section are listed in Table 2-11 along with the data quality score. See Appendix D for more details about data source evaluation.

Table 2-11. Compounding of Polystyrene to Produce XPS Masterbatch Release Data Source Evaluation

Source Reference	Data Type	Value	Overall Confidence Rating of Data
(ECHA 2008b)	Site-Specific Release Data	See Table 2-10	High
(ECHA 2008b)	“Worst-Case” Emission Factors	7.42x10 ⁻⁵ to water and 7.31 x10 ⁻⁶ to air	High
(ECB 2003)	Release Days	10 to 60 days/year for all releases	Medium

Environmental Release Assessment Results

The variables used for calculating releases with Equation 2-1 are summarized in Table 2-12.

Table 2-12. Input Variables to Equation 2-1 for XPS Masterbatch Production

Input Variable				
V (of HBCD)	N _s (sites)	f (kg HBCD released/kg HBCD processed)		N _d (days/yr)
		Average calculated from EURAR data	“Worst-case” given in EURAR	
100,000 pounds/year = 45,359 kg/year	1	6.12E-06 to stack air and/or fugitive air 3.22E-05 to surface water, onsite WWT, and/or POTW	7.31E-06 to stack air and/or fugitive air 7.42E-05 to surface water, onsite WWT, and/or POTW	10-60
^a CDR reporting threshold for small manufacturers (U.S. EPA 2016b)				

The daily amount of solid HBCD released per site from compounding of polystyrene to produce XPS masterbatch was calculated with Equation 2-1. The results of these calculations are summarized in Table 2-13.

Strengths, Limitations, and Confidence in Assessment Results

EPA has medium to high confidence in the assessed range of daily release rates presented above. EPA considered the quality of the data, the assessment approach, and uncertainties in assessment results to determine the level of confidence.

As detailed in Table 2-11, the result of EPA’s systematic review is data with an overall confidence rating of high or medium, which is a strength of the assessment. In particular, the overall confidence rating of the data pertaining to the number of release days is medium.

Another strength of the assessment approach is the estimation of HBCD emission factors and number of release days as ranges of values to account for variability in the values of these two parameters that EPA obtained or estimated. Furthermore, the strength of the assessment approach is the estimation of the daily release of HBCD per site as a range of values which encompasses the range of emission factors and the number of release days that EPA obtained or estimated.

There is uncertainty about the extent to which the emission factor data, including the emission factors calculated from release and processing volume data, and the data on number of days of release per year are applicable to the HBCD processing that would occur in the U.S. Based on the strength and uncertainty of the assessment, EPA has medium to high confidence in the assessment results.

Table 2-13. Summary of HBCD Releases from XPS Masterbatch Production

Release Source	Method of Release, Disposal, Treatment, or Discharge ^a	Releases calculated from average emission factor based on EURAR release data ^b					Releases calculated from worst case emission factor as it was reported in the EURAR ^b				Number of Sites	Hours of Release per Day (hr/day)
		Total Annual Release for All Sites (kg/yr)	Annual Release Per Site (kg/site-yr)	Daily Release (kg/site-day)		Total Annual Release for All Sites (kg/yr)	Annual Release Per Site (kg/site-yr)	Daily Release (kg/site-day)				
				Number of release days: 10 days/year	Number of release days: 60 days/year			Number of release days: 10 days/year	Number of release days: 60 days/year			
Unknown – these data were reported by EU sites in the EURAR as total annual release per site	May go to one or more: Stack air or fugitive air	0.278	0.278	0.028	4.63E-03	0.332	0.332	0.033	5.53E-03	1	8 hours/day	
Unknown – these data were reported by EU sites in the EURAR as total annual release per site	May go to one or more: Surface Water, Onsite WWT, or POTW	1.46	1.46	0.15	2.44E-02	3.37	3.37	0.337	5.61E-02	1	8 hours/day	

^a The method of release, disposal, treatment, or discharge may include some or all of those listed depending on site-specific conditions, including type of equipment use, size of the site, and waste handling practices, including any pollution controls used.

^b Release estimates are quantities of HBCD. The physical form of these releases is solid HBCD or solid mixtures containing polystyrene and HBCD.

2.2.4 Processing to Produce XPS Foam using XPS Masterbatch

XPS masterbatch is used to make XPS foam. The HBCD content in the XPS masterbatch ranges from 40 to 70 weight percent within the XPS masterbatch pellets or granules ([NICNAS 2012b](#); [ECHA 2008b](#)).

Once received at XPS foam production sites, the XPS masterbatch, along with additional polystyrene and other additives such as dyes, are charged to an extruder ([ECHA 2008b](#)). In the extruder, the polystyrene is melted, allowing the HBCD and other additives to become suspended in a polymer gel. Blowing agent is added to the gel, the gel is cooled, and it is then extruded through a die where the blowing agent volatilizes. This volatilization within the plastic gel causes the plastic to become a foam as it is extruded ([ECHA 2008b](#)). HBCD content in XPS foam ranges from 0.5 to 3 wt% ([U.S. EPA 2015a](#); [Takigami et al. 2014](#); [EC/HC 2011](#); [ECHA 2008b](#)).

Once the XPS foam is made, it may be cut, sawed, or machined into various shapes (often referred to as secondary processing), shrink-wrapped, palleted, and shipped to structural insulated panels (SIPs) and automobile replacement part production sites or directly to end users for installation into structures such as buildings ([ECHA 2008b](#)). Additionally, XPS foam scraps from secondary processing or off-specification products may be ground and recycled back into the XPS foam production process (often referred to as reclamation) ([ECHA 2008b](#)).

Environmental Release Assessment Methodology

Facility Estimates

As discussed in Section 2.2.1, EPA estimates environmental releases based on a processing volume of 100,000 pounds per site per year and estimates a single unidentified site for this exposure scenario.

Release Sources

Based on the process description, EPA infers that HBCD releases may occur from: dust generation during unloading the XPS masterbatch from the bags in which they were received; disposal of the bags in which the XPS masterbatch is received; and periodic cleaning of process equipment.

Foam manufacturing sites may also generate dust and scraps from cutting or trimming of XPS foam into panels or other shapes for shipment to end users. However, both the EU and Australian risk assessments specify that industry provided information indicated that generated dust and trimmings may be recycled back into the foam molding process, thereby reducing or eliminating waste from the cutting and trimming process ([NICNAS 2012b](#); [ECHA 2008b](#)). EPA does not know the extent that these practices are used in the United States and the assessed EURAR data is expected to account for any releases from this source ([ECHA 2008b](#)).

Emission Factors

EPA estimated emission factors based on site-specific solid HBCD release data reported in the EURAR ([ECHA 2008b](#)). The EURAR identified 17 sites in the EU that produce XPS foam using XPS masterbatch that is flame retarded with HBCD ([ECHA 2008b](#)). Site-specific release quantities are provided for four of these sites, which are summarized in Table 2-14. The EURAR indicates that these sites did not provide air releases and that these air emissions were calculated using emission factors from a study on emissions at three European XPS foam manufacturing plants ([ECHA 2008b](#)). To maintain confidentiality, the EURAR did not provide site-specific HBCD process volumes with which site-specific emission factors could be calculated. However, the EURAR provided the total production

volume for the four sites for which release data are available. EPA calculated overall average emission factors to air and water by dividing the total HBCD releases to air or water from all four sites by the total HBCD processing volume for the four sites. From these calculations, EPA estimated average emission factors of 1.07×10^{-5} kg HBCD discharged/kg HBCD processed to water and 5.79×10^{-5} kg HBCD released/kg HBCD processed to air.

The EURAR also calculated estimates of releases to wastewater and air from 13 sites that did not provide release data by using “worst-case” emission factors that the EURAR calculated from the available site-specific HBCD release and processing volume data. However, the EURAR did not provide the “worst-case” emission factors used to determine these estimates. EPA calculated “worst-case” emission factors by using the total “worst-case” release estimates calculated by the EURAR for the 13 sites and the HBCD processing volume identified in the EURAR for these 13 sites, as presented in Table 2-14. EPA calculated “worst-case” emission factors to be 2.63×10^{-5} kg HBCD discharged/kg HBCD processed to water and 5.80×10^{-5} kg HBCD released/kg HBCD processed to air. The “worst-case” air emission factor and average air emission factor are the same because the EURAR used the same emission factor from a study of three European XPS foam manufacturing plants, as described above ([ECHA 2008b](#)).

The EURAR indicates that wastewater discharges are to wastewater treatment. EPA did not find information about the prevalence of wastewater treatment at processing sites in the United States and hence assumed that wastewater discharges from this exposure scenario can be to surface water, POTW, and/or onsite wastewater treatment. The EURAR does not specify if the reported air releases for these three sites are to stack or fugitive air. Sites may implement dust capture technologies that affect if this release is to stack or fugitive air. EPA did not find information about the prevalence of dust capture technologies at processing sites in the United States and hence assumed this release may include stack air and/or fugitive air.

Table 2-14. HBCD Release Data Reported in the EURAR for Manufacturing of XPS Foam from XPS Masterbatch

Site	Release to Water	Release to Air ^a	Process Volume
	kg/yr	kg/yr	
Site 1	2.2	0.31	The EURAR identifies a total of 719 metric tons of HBCD is processed at the 4 sites with site-specific release data.
Site 2	0	18	
Site 3	1.3	14	
Site 4	4.2	9.3	
Total “worst-case” emissions calculated in the EURAR for 13 sites without release data	26.67	58.617	The EURAR identifies a total of 1,011 metric tons of HBCD is processed at the 13 sites without release data.

^a These air releases were not reported by the sites by were estimated in the EURAR using emission factors from a study on emissions from three European XPS foam manufacturing sites ([ECHA 2008b](#)).

Number of Release Days

The site-specific data in the EURAR indicates wastewater discharges occur over 1 to 15 days/year, which are values reported by the sites. Only one site reported emission days for air releases, reporting 15 days/year. Based on these data, EPA estimated wastewater discharges over a range of 1 to 15 days/year. The remaining three sites did not report emission days for air releases and the EURAR estimated 300 air emission days for all the sites using defaults in the European Communities Technical Guidance Document for industrial use in the polymers industry and processing volume at the individual sites ([ECB 2003](#)). Using this same European guidance and EPA's HBCD processing volume of 100,000 pounds HBCD/year (45.4 metric tons), EPA estimated 16 days of emission per year. In lieu of using a range of 15 to 16 days of air emission per year, EPA used 1 day/year as the lower bounding estimate, using the same low-end of emission days as that reported by the EU sites for wastewater discharges, and 16 days/year based on the European Communities Technical Guidance Document.

The data sources used to estimate releases in this section are listed in Table 2-15 along with the data quality score. See Appendix D for more details about data source evaluation.

Table 2-15. XPS Foam Manufacturing Using XPS Masterbatch Release Data Source Evaluation

Source Reference	Data Type	Value	Overall Confidence Rating of Data
(ECHA 2008b)	Site-Specific Release Data	See Table 2-14	High
(ECHA 2008b)	“Worst-Case” Emissions for Sites without Release Data	2.63x10 ⁻⁵ to water and 5.80x10 ⁻⁵ to air	High
(ECHA 2008b)	Release Days	1 to 15 days/year for water releases; 15 days/year for air releases	High
(ECB 2003)	Release Days	16 days/year for all releases	Medium

Environmental Release Assessment Results

The variables used for calculating releases with Equation 2-1 are summarized in Table 2-16.

Table 2-16. Input Variables to Equation 2-1 for XPS Foam Manufacturing Using XPS Masterbatch

Input Variable				
V (of HBCD)	Ns (sites)	f (kg HBCD released/kg HBCD processed)		Na (days/yr)
		Average calculated from EURAR data	“Worst-Case” calculated from EURAR data	
100,000 pounds/year = 45,359 kg/year ^a	1	5.79E-05 to stack air and/or fugitive air 1.08E-05 to surface water, onsite WWT, and/or POTW	5.80E-05 to stack air and/or fugitive air 2.63E-05 to surface water, onsite WWT, and/or POTW	1-15 (wastewater discharge), 1-16 (air release)
^a CDR reporting threshold for small manufacturers (U.S. EPA 2016b)				

The daily amount of solid HBCD released per site from XPS foam manufacturing from XPS masterbatch was calculated with Equation 2-1. The results of these calculations are summarized in Table 2-17.

Strengths, Limitations, and Confidence in Assessment Results

EPA has medium to high confidence in the assessed range of daily release rates presented above. EPA considered the quality of the data, the assessment approach, and uncertainties in assessment results to determine the level of confidence.

As detailed in Table 2-15, the result of EPA's systematic review is data with an overall confidence rating of high or medium, which is a strength of the assessment.. In particular, the overall confidence rating of the data pertaining to the number of release days is high or medium.

The strength of the assessment approach is the estimation of HBCD emission factors and number of release days as ranges of values to account for variability in the values of these two parameters that EPA obtained or estimated. Furthermore, the strength of the assessment approach is the estimation of the daily release of HBCD per site as a range of values which encompasses the range of emission factors and the number of release days that EPA obtained or estimated.

There is uncertainty about the extent to which the emission factor data, including the emission factors calculated from release and processing volume data, and the data on number of days of release per year are applicable to the HBCD processing that would occur in the U.S. Based on the strength and uncertainty of the assessment, EPA has medium to high confidence in the assessment results.

Table 2-17. Summary of HBCD Releases from XPS Foam Manufacturing Using XPS Masterbatch

Release Source	Method of Release, Discharge, Treatment, or Disposal ^a	Releases calculated from average emission factor based on EURAR release data ^b				Releases calculated from “worst case” emission factor based on EURAR release data ^b				Number of Sites	Hours of Release per Day (hr/day)
		Total Annual Release for All Sites (kg/yr)	Annual Release Per Site (kg/site-yr)	Daily Release (kg/site-day)		Total Annual Release for All Sites (kg/yr)	Annual Release Per Site (kg/site-yr)	Daily Release (kg/site-day)			
				Number of release days: 1 day/year (water and air)	Number of release days: 15 day/year (water) and 16 day/year (air)			Number of release days: 1 day/year (water and air)	Number of release days: 15 day/year (water) and 16 day/year (air)		
Unknown – these data were reported by EU sites in the EURAR as total annual release per site	May go to one or more: Stack air or fugitive air	2.63	2.63	2.63	0.164	2.63	2.63	2.63	0.164	1	8 hours/day
Unknown – these data were reported by EU sites in the EURAR as total annual release per site	May go to one or more: Surface Water, Onsite WWT, or POTW	0.486	0.486	0.486	3.24E-02	1.19	1.19	1.19	0.080	1	8 hours/day

^a The method of release, disposal, treatment, or discharge may include some or all of those listed depending on site-specific conditions, including type of equipment use, size of the site, and waste handling practices, including any pollution controls used.

^b Release estimates are quantities of HBCD. The physical form of these releases is solid HBCD or solid mixtures containing polystyrene and HBCD.

2.2.5 Processing of HBCD to Produce XPS Foam

XPS foam can be produced from either XPS masterbatch, as described in Section 2.2.4, or from HBCD powder or granules. The process for producing XPS foam from HBCD powder is similar to that for production of HBCD foam from XPS masterbatch. Polystyrene, HBCD powder, and other additives are fed into an extruder, where the contents are melted to produce a plastic gel. Blowing agent is added to the gel, which is then sent through a die where the blowing agent volatilizes, producing the extruded plastic foam. The foam may be cut into shapes, packaged, and shipped to customers. HBCD content in XPS foam ranges from 0.5 to 3 weight percent ([U.S. EPA 2015a](#); [Takigami et al. 2014](#); [EC/HC 2011](#); [ECHA 2008b](#)).

Environmental Release Assessment Methodology

Facility Estimates

As discussed in Section 2.2.1, EPA estimates environmental releases based on a processing volume of 100,000 pounds per site per year and estimates a single unidentified site for this exposure scenario.

Release Sources

Based on the process description, EPA infers that releases may occur from: dust generation during unloading the HBCD powder from the bags in which they were received; disposal of the bags in which the HBCD powder is received; and periodic cleaning of process equipment.

Foam manufacturing sites may also generate dust and scraps from cutting or trimming of XPS foam into panels or other shapes for shipment to end users. However, both the EU and Australian risk assessments specify that industry provided information indicating that generated dust and trimmings may be captured and recycled back into the foam molding process, thereby reducing or eliminating waste from the cutting and trimming process ([NICNAS 2012b](#); [ECHA 2008b](#)). EPA does not know the extent to which these practices are used in the United States and the assessed TRI and EURAR data is expected to account for any releases from this source ([ECHA 2008b](#)).

EPA estimated releases from this exposure scenario using 2017 TRI data and emission factors calculated from release data from the EURAR. EPA assessed both approaches because the company that reported to 2017 TRI indicated that they no longer conduct operations with HBCD, as discussed below and did not report to 2018 TRI as indicated in Section 1.2.4.

TRI Data

The Dow Chemical Company reported releases for two sites that manufacture XPS foam with HBCD. The company has since indicated that operations with HBCD have ceased. The Dow Chemical Company communicated with EPA that they imported roughly 48 metric tons in 2017 as discussed earlier in Section 1.2, which is similar to the importation and processing volume of HBCD that EPA uses to estimate releases for this exposure scenario (approximately 45.4 metric tons) with the EURAR data. EPA assessed the 2017 TRI releases as they were reported by Dow. These releases are deemed to be representative of the potential releases that may occur from sites in the United States that would manufacture XPS foam with HBCD because the processed volume associated with these releases is approximately equal to the assessed processing volume. The reported releases are summarized in the next section along with the releases EPA calculated from the EURAR data. As discussed, the HBCD processing volume associated with the releases reported in the 2017 TRI (48 metric tons HBCD, provided through communication with Dow and discussed in Section 1.2) is slightly different than the volume EPA used to estimate releases from the EURAR data (45.4 metric tons).

Emission Factors

Although TRI data are available for this exposure scenario, EPA also estimated emission factors based on site-specific release data reported in the EURAR ([ECHA 2008b](#)). The EURAR identified 18 sites in the EU that produce XPS foam using HBCD powder ([ECHA 2008b](#)). Site-specific solid HBCD release quantities are provided for 17 of these sites and a calculated release estimate was provided for the remaining site. To maintain confidentiality, the EURAR did not provide site-specific HBCD processing volumes with which site-specific emission factors could be calculated. The EURAR only provided the total HBCD processing volume for all 18 sites ([ECHA 2008b](#)).

EPA calculated overall average emission factors to water and air with this data by dividing the total HBCD releases for water or air for all sites by the total HBCD processing volume for all sites. The average emission factors are presented in Table 2-18.

The EURAR indicates that the HBCD release estimates to water presented in Table 2-18 may be estimated quantities either directly from process operations or from onsite wastewater treatment at these sites. The EURAR does not specify this detail for the individual sites, thus EPA is uncertain of the prevalence of onsite wastewater treatment at these European sites. For this Risk Evaluation, EPA assessed that wastewater discharges estimated using the emission factor determined from the EURAR data may be entirely to on or offsite wastewater treatment or to surface water. Depending on site-specific pollution controls, wastewater discharges can be to surface water, POTW, and/or onsite wastewater treatment and air releases may include stack air and/or fugitive air.

Table 2-18. HBCD Release Data Reported in the EURAR for Manufacturing of XPS Foam using HBCD Powder

Site-Specific Release Data	Release to Water	Release to Air	Process Volume
	kg/yr	kg/yr	
Site 1	4.4	1.5	The EURAR identifies a total of 3,232 metric tons of HBCD are processed into XPS masterbatch by 18 sites.
Site 2	1.2	1.4	
Site 3	0.055	3.7	
Site 4	3.7	1.5	
Site 5	0.0024	1.1	
Site 6	0	0.73	
Site 7	6	0.54	
Site 8	0.0029	0.7	
Site 9	0.0019	0.15	
Site 10	0	0.4	
Site 11	0	1.8	
Site 12	0	1.8	
Site 13	0.11	1.2	
Site 14	15	1.5	
Site 15	0.00004	0.59	
Site 16	0.0004	0.91	

Site 17	0.021	3.8	
Site 18	2.5	0.23	

Number of Release Days

The site-specific data in the EURAR indicates wastewater discharges occur over 1 to 12 days/year, which are values reported by the EU sites. Based on these data, EPA estimated wastewater discharges over a range of 1 to 12 days/year. None of these sites reported emission days for air releases. For these sites, the EURAR estimated 42 to 300 air emission days using defaults in the European Communities Technical Guidance Document for industrial use in the polymers industry and processing volume ([ECB 2003](#)). Using this same European guidance and a processing volume of 100,000 pounds HBCD/year (45.4 metric tons), EPA estimated 16 days of emission per year. EPA used 1 day/year for air emissions as the lower bounding estimate, using the same low-end of emission days as that reported by the EU sites for wastewater discharges, and 16 days/year based on the European Communities Technical Guidance Document.

The data sources used to estimate releases in this section are listed in Table 2-19 along with the data quality score. See Appendix D for more details about data source evaluation.

Table 2-19. Manufacturing of XPS Foam Using HBCD Powder Release Data Source Evaluation

Source Reference	Data Type	Value	Overall Confidence Rating of Data
(ECHA 2008b)	Site-Specific Release Data	See Table 2-18. HBCD Release Data Reported in the EURAR for Manufacturing of XPS Foam using HBCD Powder	High
(U.S. EPA 2017g)	Site-Specific Release Data	See Table 2-22. Summary of HBCD Releases from XPS Foam Manufacturing Using HBCD from 2017 TRI Data	Medium
(ECHA 2008b)	Release Days	1 to 12 days/year for wastewater discharges	High
(ECB 2003)	Release Days	16 days/year for all releases	Medium

Environmental Release Assessment Results

The releases reported by the Dow Chemical Company in the 2017 TRI for sites that manufacture XPS articles with HBCD are presented in Table 2-22. The data in 2017 TRI is reported for the calendar year. EPA calculated daily releases with the TRI data using the same estimates for days per year that is discussed above. EPA also calculated releases using Equation 2-1 and the EURAR data discussed above, and the input variables for this calculation are given in Table 2-20. The results of these calculations are summarized in Table 2-21.

Table 2-20. Input Variables to Equation 2-1 for XPS Foam Manufacturing Using HBCD Powder

Input Variable			
Volume (of HBCD)	Ns (sites)	f (kg HBCD released/kg HBCD processed)	Nd (days/yr)
		Average calculated from EURAR data	
100,000 pounds/year = 45,359 kg/year	1	7.29E-06 to stack air and/or fugitive air 1.02E-05 to surface water, onsite WWT, and/or POTW	1-12 (water), 1-16 (air)
^a CDR reporting threshold for small manufacturers (U.S. EPA 2016b)			

Strengths, Limitations, and Confidence in Assessment Results

EPA has medium to high confidence in the assessed range of daily release rates. EPA also assessed releases using TRI data which EPA assigned an overall confidence rating of medium using systematic review. EPA considered the quality of the data, the assessment approach, and uncertainties in assessment results to determine the level of confidence.

As detailed in Table 2-19, the result of EPA's systematic review is data with an overall confidence rating of high or medium, which is a strength of the assessment.. In particular, the overall confidence rating of the data pertaining to the number of release days is high or medium.

The strength of the assessment approach is the estimation of number of release days as ranges of values to account for variability in parameters that EPA obtained or estimated. Furthermore, the strength of the assessment approach is the estimation of the daily release of HBCD per site as a range of values which encompasses the number of release days and different sources of release data that EPA obtained or estimated.

There is uncertainty about the extent to which the emission factor data, including the emission factors calculated from release and processing volume data, and the data on number of days of release per year are applicable to the HBCD processing that would occur in the U.S. Based on the strength and uncertainty of the assessment, EPA has medium to high confidence in the assessment results.

Table 2-21. Summary of HBCD Releases from XPS Foam Manufacturing Using HBCD

Release Source	Method of Release, Disposal, Treatment, or Discharge ^a	Releases calculated from average emission factor based on EURAR release data ^b				Number of Sites	Hours of Release per Day (hr/day)
		Total Annual Release for All Sites (kg/yr)	Annual Release Per Site (kg/site-yr)	Daily Release (kg/site-day)			
				Number of release days: 1 day/year (water and air)	Number of release days: Over 12 day/year (water) and 16 day/year (air)		
Unknown – these data were reported by EU sites in the EURAR as total annual release per site	May go to one or more: Stack air or fugitive air	0.331	0.331	0.331	2.07E-02	1	8 hours/day
Unknown – these data were reported by EU sites in the EURAR as total annual release per site	May go to one or more: Surface Water, Onsite WWT, or POTW	0.463	0.463	0.463	0.039	1	8 hours/day

^a The method of release, disposal, treatment, or discharge may include some or all of those listed depending on site-specific conditions, including type of equipment use, size of the site, and waste handling practices, including any pollution controls used.

^b Release estimates are quantities of HBCD. The physical form of these releases is solid HBCD or solid mixtures containing polystyrene and HBCD.

Table 2-22. Summary of HBCD Releases from XPS Foam Manufacturing Using HBCD from 2017 TRI Data

Site identity	2017 TRI			Hours of Release per Day (hr/day)
	Annual Quantities per Site (kg/year)	Daily Release (kg/site-day)		
		Assuming low-end of 1 day/year	Assuming high-end of 16 days/year	
Dow Chemical Company, Pevly MO	Stack air ^a : 1.81 Off-site transfer for Incineration ^b : 30.8 Off-site transfer for disposal to landfill ^c : 123	Stack air ^a : 1.81 Off-site transfer for Incineration ^b : 30.8 Off-site transfer for disposal to landfill ^c : 123	Stack air ^a : 0.113 Off-site transfer for incineration ^b : 1.93 Off-site transfer for disposal to landfill ^c : 7.68	8 hours/day
Dow Chemical Company, Dalton GA	Stack air ^a : 21.3 Off-site transfer for disposal to landfill ^c : 109 Off-site transfer for incineration ^d : 23.1	Stack air ^a : 21.3 Off-site transfer for disposal to landfill ^c : 109 Off-site transfer for incineration ^d : 23.1	Stack air ^a : 1.33 Off-site transfer for disposal to landfill ^c : 6.80 Off-site transfer for incineration ^d : 1.45	8 hours/day

^a These stack air releases were reported under Section 5.2 of the TRI Form R, which correspond to on-site stack or point air emissions.

^b This incineration quantity was reported under Section 6.2 of the TRI Form R, which corresponds to code M50, which is off-site transfer for incineration/thermal treatment.

Site identity	2017 TRI		Hours of Release per Day (hr/day)	
	Annual Quantities per Site (kg/year)	Daily Release (kg/site-day)		
		Assuming low-end of 1 day/year		Assuming high-end of 16 days/year
^c This landfill quantity was reported under Section 6.2 of the TRI Form R, which corresponds to code M64, which is off-site transfer for disposal to other landfills.				
^d This incineration quantity was reported under Section 6.2 of the TRI Form R, which corresponds to code M56, which is off-site transfer for energy recovery. EPA assumes this is to incineration.				

2.2.6 Processing to Produce EPS Foam from Imported EPS Resin Beads

To manufacture EPS, EPS beads are first pre-expanded by heating with steam, which causes the beads to soften and expand to the desired density, as the temperature of the steam exceeds that of the blowing agent (such as pentane) incorporated in the beads ([NICNAS 2012b](#); [ECHA 2008b](#)). Once pre-expansion is completed, the beads are dried, then placed in shape or block molds. In the molds, the pressure is dropped with a vacuum pump, eliminating air and water and causing the expanded beads to fuse and take the shape of the mold ([NICNAS 2012b](#)). The EPS foam is then removed from the molds and cooled.

The shapes or blocks may be cut into smaller sizes and trimmings may be recycled back into the foam production process (*i.e.*, secondary processing) ([ECHA 2008b](#)). The EPS foam is then wrapped for transport and shipped either to customers who may further process the foam into SIPs or automobile replacement parts or directly to end users for installation in structures such as buildings and cars. HBCD content in the EPS foam is typically from 0.5 to 0.7 weight percent, with the usual content being 0.7 weight percent ([ECHA 2017c](#); [NICNAS 2012b](#); [ECHA 2009b](#); [Thomsen et al. 2007](#)).

Environmental Release Assessment Methodology

Facility Estimates

As discussed in Section 2.2.1, EPA estimates environmental releases based on a processing volume of 100,000 pounds per site per year and estimates a single unidentified site for this exposure scenario.

Release Sources

Based on the process description, EPA infers that releases may occur from: dust generation during unloading the EPS resin beads from the bags in which they were received; disposal of the bags in which the EPS resin beads are received; and periodic cleaning of process equipment.

Foam manufacturing sites may also generate dust and scraps from cutting or trimming of EPS foam into panels or other shapes for shipment to end users. However, both the EU and Australian risk assessments specify that industry provided information indicating that generated dust and trimmings may be captured and recycled back into the foam molding process, thereby reducing or eliminating waste from the cutting and trimming process ([NICNAS 2012b](#); [ECHA 2008b](#)). EPA does not know the extent that these practices are used in the United States and assessed these release sources as described below.

Emission Factors

EPA used emission factors given in the 2009 OECD ESD on Plastics Additives, as summarized in Table 2-23. Per the OECD ESD, unloading of EPS resin beads is not expected to generate dust. However, there may be residual resin in the transport containers. The OECD ESD estimates an emission factor of 1% from the disposal of transport containers, which the OECD ESD indicates are disposed of as solid waste to landfills. Although there is no statistical characterization of this emission factor, EPA believes the 1% emission factor is in the upper end of the distribution based on EPA's experience. The OECD ESD indicates that the converting process may result in dust generation at a loss rate of 0.1 to 0.5%, which is initially released to air, with particles eventually settling and being disposed of as solid waste or discharged as wastewater ([OECD 2009](#)). Per the *EPA/OPPT Solids Transfer Dust Loss Model*, dust releases are similarly estimated with a 0.5% emission factor and initial release to air with subsequent treatment via incineration, disposal to landfill, or discharge as wastewater from wiping and cleaning of surfaces onto which particles have settled ([U.S. EPA 2013a](#)). The method of release, disposal, treatment, or discharge is dependent on any pollution controls that are implemented at that site, as well as other factors such as the equipment used and size of the site. EPA did not find information about the prevalence of dust capture and control technologies at importation sites in the United States. EPA estimated dust releases with a range of release from 0.1 to 0.5%. The method of release, disposal, treatment, or discharge may be some or all of the following: stack air, fugitive air, onsite wastewater, POTW, landfill, or incineration, per the OECD ESD and EPA/OPPT model.

The OECD ESD identifies trimming of produced foam as a release source, estimating a release of 2.5% to solid waste or water from grinding or machining of the foam. EPA also identified foam trimming release of 1% to solid waste for closed-cell spray polyurethane foam (SPF). These data were reported by industry for the development of the draft generic scenario on SPF application ([U.S. EPA 2018d](#)). While this foam is different than that in this exposure scenario, EPA uses this emission factor of 1% to present a range of potential releases from the trimming of foam. EPA assessed this release via disposal to landfill or treatment via incineration, as the foam scraps are likely disposed of as solid waste ([U.S. EPA 2018d](#); [OECD 2009](#)). The method of release, disposal, treatment, or discharge is dependent on any pollution controls that are implemented at that site, as well as other factors such as the equipment used and size of the site. EPA did not find information on waste handling procedures at these sites. HBCD may be disposed of to landfill and/or treated via incineration.

Based on the process description for this exposure scenario, EPA expects that equipment cleaning may be another source of release. EPA estimated this release using the OECD ESD, which estimates an emission factor of 1% for all other operations than previously discussed, which EPA assumes includes equipment cleaning ([OECD 2009](#)). In addition, the *EPA/OPPT Solid Residuals in Transport Containers Model* also estimates a loss of 1% of processed material. Although there is no statistical characterization of this emission factor, EPA believes the 1% emission factor is in the upper end of the distribution based on EPA's experience. The method of release, disposal, treatment, or discharge is dependent on any pollution controls that are implemented at that site, as well as other factors such as the equipment used and size of the site. EPA did not identify information on waste handling procedures at these sites. The method of release, disposal, treatment, or discharge may include some or all of the following depending on site-specific conditions: surface water, POTW, onsite WWT, POTW, landfill, or incineration.

Table 2-23. Summary of HBCD Releases During Manufacturing of EPS Foam from the 2009 OECD ESD on Plastics Additives and Standard EPA/OPPT Models

Release Source	Emission factor used in this Risk Evaluation	Method of Release, Disposal, Treatment, or Discharge Assessed in this Risk Evaluation ^a	Basis or Source
Dust generation from unloading EPS resin beads from transport containers	N/A – HBCD dust generation from unloading EPS resin beads is expected to be minimal. Additionally, HBCD is entrained within the polymer matrix.		(NICNAS 2012b ; ECHA 2008b)
Disposal of transport containers (bags) containing solid HBCD residual	0.01 kg HBCD released/kg HBCD in containers	Landfill	(OECD 2009)
Dust / volatilization releases at elevated temperatures during converting process	0.001-0.005 kg HBCD released/kg HBCD processed	Uncertain: Stack air, Fugitive Air, surface water, onsite WWT, POTW, Landfill, Incineration	(OECD 2009)
Equipment cleaning losses of residual HBCD solids from compounding equipment	0.01 kg HBCD released/kg HBCD processed	Uncertain – Surface water, onsite WWT, POTW, Landfill, Incineration	(OECD 2009)
Trimming of foam ^a	0.01 to 0.025 kg HBCD released/kg HBCD processed	Uncertain Incineration, Landfill	(U.S. EPA 2018d ; OECD 2009)
N/A = Not applicable ^a Trimmed foam may be reintroduced into the process and not disposed of based on the information in the EURAR and Australian risk assessment (NICNAS 2012b ; ECHA 2008b). EPA includes this release to present a range if release estimates.			

EPA's method of assessing emission factors and the methods of assessing the emission factors pertaining to releases from the manufacture of EPS foam from EPS resin beads as reported in EURAR and NICNAS ([NICNAS, 2012b](#); [ECHA, 2008b](#)) are similar because in all cases emission factors were obtained from an OECD ESD or other similar method. The EURAR and NICNAS only assessed dust releases during the converting process, and did not assess releases from unloading, disposal of transport containers and equipment cleaning. Accordingly, EPA's overall emission factor is considerably greater than the emission factors used in these assessments, and EPA's assessment may be conservative.

Number of Release Days

EPA estimated the number of release days based on information given in the European Communities Technical Guidance Document ([ECB 2003](#)) and in the Australian risk assessment. EPA estimated 16 release days per year using the European Communities Technical Guidance Document for industrial use in the polymers industry and a processing volume of 100,000 pounds HBCD/year (45.4 metric tons), The Australian risk assessment includes one estimate of the number of operational days per year at an EPS foam production plant. This plant reports producing EPS products containing HBCD 8 to 10 times per year, with each production lasting up to 14 days. This results in production for 112 to 140 days per year. In conclusion, EPA estimated a range of 16 to 140 days/year.

The data sources used to estimate releases in this section are listed in Table 2-24 along with the data quality score. See Appendix D for more details about data source evaluation.

Table 2-24. Manufacturing of EPS Foam from Imported EPS Resin Beads Release Data Source Evaluation

Source Reference	Data Type	Value	Overall Confidence Rating of Data
(NICNAS 2012b)	Release Days	112 to 140 days/year for all releases	High
(ECB 2003)	Release Days	16 days/year for all releases	Medium

Environmental Release Assessment Results

The variables used for calculating releases with Equation 2-1 are summarized in Table 2-25 below.

Table 2-25. Input Variables to Equation 2-1 for EPS Foam Manufacturing from EPS Resin Beads

Input Variable				
V (of HBCD)	Ns (sites)	f (kg HBCD released/kg HBCD processed)		Na (days/yr)
		Lower value of emission factors	Upper value of emission factors	
100,000 pounds/year = 45,359 kg/year	1	0.01 to landfill	0.01 to landfill	16-140
		0.001 to stack air, fugitive air, surface water, onsite WWT, POTW, landfill, and/or incineration	0.005 to stack air, fugitive air, surface water, onsite WWT, POTW, landfill, and/or incineration	
		0.01 to surface water, onsite WWT, POTW, landfill, and/or incineration	0.01 to surface water, onsite WWT, POTW, landfill, and/or incineration	
		0.001 to incineration and/or landfill	0.025 to incineration and/or landfill	

^a CDR reporting threshold for small manufacturers ([U.S. EPA 2016b](#))

The daily amount of HBCD released per site from EPS foam manufacturing from EPS resin beads was calculated with Equation 2-1. The results of these calculations are summarized in Table 2-26.

Strengths, Limitations, and Confidence in Assessment Results

EPA has medium confidence in the assessed range of daily release rates presented above. EPA considered the quality of the data, the assessment approach, and uncertainties in assessment results to determine the level of confidence.

As detailed in Table 2-24, the result of EPA's systematic review is data pertaining to the number of release days with an overall confidence rating of high or medium, which is a strength of the assessment.

EPA did not find release data in TRI or the EURAR that are applicable to this exposure scenario. EPA estimated releases at EPS foam production sites using emission factors from the 2009 OECD ESD on Plastic Additives ([OECD 2009](#)), the draft generic scenario on SPF application ([U.S. EPA 2018d](#)), and an EPA/OPPT model available in ChemSTEER ([U.S. EPA 2013a](#)). The higher emission factor in the ESD for dust releases corresponds to the same factor used in the EPA/OPPT Solids Transfer Dust Loss

Model, which is based on U.S. release data ([U.S. EPA 2013a](#)). Additionally, the emission factor from the draft generic scenario on SPF application ([U.S. EPA 2018d](#)) is based on industry input. The representativeness of these data toward the true distribution of environmental releases for this use is uncertain and EPA notes that those from the ESD and EPA/OPPT model are likely on the higher end of the distribution. There is uncertainty in the estimate of the range of release days that is based on industry data that are included in the Australian risk assessment ([NICNAS 2012b](#)). The data from the Australian risk assessment is not correlated to an HBCD throughput, so EPA could not adjust the number of days by the assessed production volume (*i.e.*, 100,000 pounds HBCD/year). Based on the strengths and uncertainties of the assessment, EPA has medium confidence in the assessment results.

Table 2-26. Summary of HBCD Releases from EPS Foam Manufacturing from EPS Resin Beads

Release Source	Method of Release, Disposal, Treatment, or discharge ^a	Releases calculated from lower value of range of emission factors ^b				Releases calculated from upper value of range of emission factors ^b				Number of Sites	Hours of Release per Day (hr/day)
		Total Annual Release for All Sites (kg/yr)	Annual Release Per Site (kg/site-yr)	Daily Release (kg/site-day)		Total Annual Release for All Sites (kg/yr)	Annual Release Per Site (kg/site-yr)	Daily Release (kg/site-day)			
				Number of release days: 16 days/year	Number of release days: 140 days/year			Number of release days: 16 days/year	Number of release days: 140 days/year		
Dust release during converting process	May go to one or more: Stack air, Fugitive Air, surface water, onsite WWT, POTW, Landfill, or Incineration	45.4	45.4	2.83	0.324	227	227	14.17	1.62	1	8 hours/day
Equipment cleaning	May go to one or more: surface water, onsite WWT, POTW, landfill, or Incineration	454	454	28.3	3.24	454	454	28.3	3.24	1	8 hours/day
Disposal of transport containers	Landfill	454	454	28.3	3.24	454	454	28.3	3.24	1	8 hours/day
Trimming foam scrap	May go to one or more: Incineration or landfill	454	454	28.35	3.24	1134	1134	70.87	8.10	1	8 hours/day

^a The method of release, disposal, treatment, or discharge may include some or all of those listed depending on site-specific conditions, including type of equipment use, size of the site, and waste handling practices, including any pollution controls used.

^b Release estimates are quantities of HBCD. The physical form of these releases is solid mixtures containing polystyrene and HBCD.

2.2.7 Processing to Produce SIPs and Automobile Replacement Parts from XPS/EPS Foam

After XPS and EPS foam is produced, the foam may be subsequently sent to specialty fabricators to produce structural insulated panels (SIPs) or automobile replacement parts.

To manufacture SIPs, the XPS and EPS foam is cut into the desired size panel, either with saws or thermal wires ([NICNAS 2012b](#)). The panels are then adhered to steel, plastic, concrete, plasterboard, or other sheathing material on either side, forming a sandwich, which is why these panels are also referred to as sandwich panels ([NICNAS 2012b](#)). Once the SIPs are produced, they are shipped to construction sites for installation.

Major automobile manufacturers have phased out use of HBCD in U.S. production but continue to use it in replacement parts, according to information provided by the Alliance of Automobile Manufacturers ([Alliance of Automobile Manufacturers 2018b](#); [Rege 2017](#); [Tatman 2017](#)). Manufacturers identified 155 replacement parts containing HBCD: these include absorbers and two types of insulator panels ([Tatman 2017](#)). For the purpose of this Risk Evaluation, EPA assumes that EPS and XPS foam containing HBCD is used in these replacement parts ([U.S. EPA 2018f, g](#)).

EPA did not identify specific information regarding the process for manufacturing of automobile parts containing XPS or EPS foam. EPA believes this process likely involves the molding and cutting of parts, similar to the manufacturing of panels and boards for construction purposes. Additionally, this process may include the bonding of the insulation with metal or plastic surfaces. After fabrication, the automobile replacement parts containing foam are likely shipped to automobile assemblers who install the parts without further cutting, shaping, or other handling of the parts.

Environmental Release Assessment Methodology

Facility Estimates

As discussed in Section 2.2.1, EPA estimates environmental releases based on a processing volume of 100,000 pounds per site per year. This processing volume is for any one site, and this section covers two exposure scenarios, Manufacturing of SIPs and Automobile Replacement Parts, so EPA developed estimates for two modeled sites, one that processes EPS and XPS foam to produce SIPs and one that processes XPS and EPS foam to produce automobile replacement parts, with 100,000 pounds HBCD/year at each site.

Release Sources

Based on the process description, EPA infers that releases likely occur at SIPs and automobile replacement part manufacturing shops from the cutting of EPS and XPS foam to produce parts of specific dimensions. Specifically, release would occur during the formation of dust during the fabrication process and from the disposal of foam scraps. Once the parts are fabricated and shipped to end-users, they are not likely to be further processed or handled in such a way that subsequent release would occur. EPA estimated releases during this exposure scenario from the cutting or sawing of foam and the subsequent disposal of foam scraps.

Emission Factors

The emission factor for particles generated by cutting XPS and EPS foam are presented in Table 2-27 ([ECHA 2008b](#)). The method of release, disposal, treatment, or discharge for generated particles containing HBCD during sawing and cutting is dependent on any pollution controls that are

implemented at that site, as well as other factors such as the equipment used and size of the site. EPA did not identify information on waste handling procedures at these sites. The method of release, disposal, treatment, or discharge may include some or all of the following depending on site-specific conditions: stack air, fugitive air, surface water, POTW, onsite WWT, landfill, and/or incineration.

EPA used the same emission factors for the trimming of XPS and EPS foam that were used in Section 2.2.6 for the manufacturing of EPS foam from EPS resin beads. Specifically, EPA uses a range of loss fractions of 1 to 2.5% of foam containing HBCD to estimate disposal of foam scrap to landfill or treatment via incineration, depending on the site's disposal practices. EPA did not identify information on waste handling procedures at these sites. Part or all of this release could be disposed of to landfill or treated via incineration. Refer to Section 2.2.6 for additional information on this release.

The emission factors for the manufacture of SIPs and automobile replacement parts are given in Table 2-27. Summary of HBCD Release Sources During the Manufacturing of SIPs and Automobile Replacement Parts from XPS/EPS Foam

Table 2-27. Summary of HBCD Release Sources During the Manufacturing of SIPs and Automobile Replacement Parts from XPS/EPS Foam

Release Source	Emission factor used in this Risk Evaluation (kg HBCD released/kg HBCD processed)		Method of Release, Disposal, Treatment, or Discharge Assessed in this Risk Evaluation	Basis or Source
	Lower value of emission factors	Upper value of emission factors		
Dust generation from thermal cutting or sawing of 10% of XPS (50%) and EPS (50%) boards	5.06E-05	2.25E-04	Uncertain: Stack air, Fugitive Air, surface water, onsite WWT, POTW, Landfill, and/or Incineration	(ECHA 2008b)
Trimming disposal	0.01	0.025	Uncertain: Incineration and/or landfill ^a	(OECD 2009) (lower fraction); (U.S. EPA 2018d) (upper fraction)

^a EPA assumed solid trimming waste disposal is to incineration and/or landfill.

Number of Release Days

EPA estimated range of emission days per year based on the European Communities Technical Guidance Document for industrial use in the polymer industry ([ECB 2003](#)). Specifically, EPA determined a range of potential emission days by calculating the lowest and highest possible emission days from the applicable defaults for industrial use in the polymer industry. With this method and the HBCD processing volume for each exposure scenario (100,000 pounds [45.4 metric tons]), EPA estimated 16 days/year. The highest number of emission days for industrial use in the polymer industry is 300 days/year. Based on these values, EPA estimated a range of 16 to 300 emission days/year.

The data sources used to estimate releases in this section are listed in Table 2-28. Manufacturing of SIPs and Automobile Replacement Parts from XPS/EPS Foam Release Data Source Evaluation along with the data quality score. See Appendix D for more details about data source evaluation.

Table 2-28. Manufacturing of SIPs and Automobile Replacement Parts from XPS/EPS Foam Release Data Source Evaluation

Source Reference	Data Type	Value	Overall Confidence Rating of Data
(ECHA 2008b)	Particle Generation Factor	See Table 2-31. Particle Generation Factors Reported in the EURAR for Sawing or Cutting of XPS/EPS Foam Prior to Installation	High
(ECB 2003)	Release Days	16 to 300 days/year for all releases	Medium

Environmental Release Assessment Results

The variables used for calculating releases with Equation 2-1 are summarized in Table 2-29.

Table 2-29. Input Variables to Equation 2-1 for the Manufacturing of SIPs and Automobile Replacement Parts from XPS/EPS Foam

Input Variable				
V (of HBCD)	N _s (sites)	F (kg HBCD released/kg HBCD processed)		N _a (days/yr)
		Lower value of emission factors	Upper value of emission factors	
200,000 pounds/year = 90,718 kg/year ^a	2 (1 for SIPs and 1 for auto parts)	5.06E-05 to Stack air, Fugitive Air, surface water, onsite WWT, POTW, landfill, and/or incineration 0.01 to landfill and/or incineration	2.25E-04 to Stack air, Fugitive Air, surface water, onsite WWT, POTW, landfill, and/or incineration 0.025 to landfill and/or incineration	16-300

^a CDR reporting threshold volume for small manufacturers were used for each exposure scenario.

The daily amount of solid HBCD released per site from cutting of XPS and EPS foam to manufacture SIPs and automobile replacement parts was calculated with Equation 2-1. The results of these calculations are summarized in Table 2-30.

Strengths, Limitations, and Confidence in Assessment Results

EPA has medium to high confidence in the assessed range of daily release rates presented above. EPA considered the quality of the data, the assessment approach, and uncertainties in assessment results to determine the level of confidence.

As detailed in Table 2-28, the result of EPA's systematic review is data with an overall confidence rating of high or medium, which is a strength of the assessment. In particular, the overall confidence rating of the data pertaining to the number of release days is medium.

The strength of the assessment approach is the estimation of HBCD emission factors and number of release days as ranges of values to account for variability in the values of these two parameters that EPA obtained or estimated. Furthermore, the strength of the assessment approach is the estimation of the daily release of HBCD per site as a range of values which encompasses the range of emission factors and the number of release days that EPA obtained or estimated.

There is uncertainty about the extent to which the emission factor data and the data on number of release days are applicable to the HBCD use activities that would occur in the U.S. Based on the strengths and uncertainty of the assessment, EPA has medium to high confidence in the assessment results.

Table 2-30. Summary of HBCD Releases from the Manufacturing of SIPs and Automobile Replacement Parts from XPS/EPS Foam

Release Source	Method of Release, Disposal, Treatment, or Discharge ^a	Releases calculated from lower value of range of emission factors ^b				Releases calculated from upper value of range of emission factors ^b				Number of Sites	Hours of Release per Day (hr/day)
		Total Annual Release for All Sites (kg/yr)	Annual Release Per Site (kg/site-yr)	Daily Release (kg/site-day)		Total Annual Release for All Sites (kg/yr)	Annual Release Per Site (kg/site-yr)	Daily Release (kg/site-day)			
				Number of release days: 16 days/year	Number of release days: 300 days/year			Number of release days: 16 days/year	Number of release days: 300 days/year		
Dust release during sawing / cutting of foam	May go to one or more: Stack air, Fugitive Air, surface water, onsite WWT, POTW, Landfill, or Incineration	4.59	2.29	0.143	7.64E-03	20.4	10.21	0.638	3.40E-02	2	8 hours/day
Trimming foam scrap	May go to one or more: Incineration or landfill	907	454	28.3	1.512	2268	1134	70.9	3.78	2	8 hours/day

^a The method of release, disposal, treatment, or discharge may include some or all of those listed depending on site-specific conditions, including type of equipment use, size of the site, and waste handling practices, including any pollution controls used.

^b Release estimates are quantities of HBCD. The physical form of these releases is solid mixtures containing polystyrene and HBCD.

2.2.8 Use: Installation of Automobile Replacement Parts

EPA did not identify specific process information regarding the installation of automobile replacement parts containing HBCD. Manufacturers identified 155 replacement parts containing HBCD, these include absorbers and insulator panels ([Alliance of Automobile Manufacturers 2018b](#)). For the purpose of this Risk Evaluation, based on CDR reporting that showed the vast majority of use of HBCD was for XPS and EPS, EPA assumes that HBCD in these replacement parts is incorporated into XPS and EPS foam and that the XPS and EPS foam containing HBCD is used to make the replacement parts.

EPA estimated releases and exposures for the manufacturing of automobile replacement parts from XPS and EPS foam in Section 2.2.7. Once manufactured, the foam automobile replacement parts are shipped to automobile assemblers who likely install the parts without further cutting, shaping, or other handling of the parts. The installation of automobile replacement parts is likely to involve removal of old parts and insertion of the replacement parts within the vehicle, which EPA does not expect to generate dusts or other sources of release. Thus, EPA does not expect releases or exposures will occur at automobile repair sites.

2.2.9 Use: Installation of XPS/EPS Foam Insulation in Residential, Public, and Commercial Buildings, and Other Structures

Fabricated SIPs or XPS and EPS foam from XPS and EPS foam manufacturing sites are installed at construction sites for continuous insulation applications such as in walls and roofs on the exterior of buildings, ceilings and subfloor systems insulation ([ECHA 2008b](#)). Specifically, these materials are used for insulation within the walls of buildings, as exterior sheathing, and in ceilings, roofs, and subfloors ([NICNAS 2012b](#)). The building and construction industry use XPS and EPS foam thermal insulation boards and laminates for sheathing products. EPS foam prevents freezing, provides a stable fill material and creates high-strength composites in construction applications ([U.S. EPA 2018f](#)). XPS foam board is used mainly for roofing applications and architectural molding. HBCD is used in both types of foams because it is highly effective at levels less than 1% and maintains the insulation properties of XPS and EPS foam ([Morose 2006](#)).

During installation of the SIPs and XPS and EPS foam that was not previously formed into SIPs, these materials may be cut or sawed at the construction site to fit into the building structure. Cutting is likely to be done manually but may be done with thermal wires at large construction sites ([ECHA 2008b](#)). The EURAR assumes that one in every 10 foam boards is cut at construction sites (*i.e.*, 10%). Due to lack of additional information, EPA estimated releases and exposures from the cutting of 10% of the amount of HBCD used for construction purposes.

Environmental Release Assessment Methodology

Facility Estimates

As discussed in Section 2.2.1, EPA evaluated this exposure scenario assuming an import volume of 100,000 pounds/year (45,359 kg/year) ([U.S. EPA 2016c](#)). EPA does not estimate releases and exposures for one site for this exposure scenario, as EPA expects this exposure scenario is more widespread. EPA calculates a range of 34 to 2,696 construction sites for this exposure scenario based on 100,000 pounds/year import volume, as described below.

The Chemical Safety Report on HBCD prepared by the European Chemicals Agency (ECHA) assesses XPS and EPS foam use rate at a large construction site as approximately 2,440 m³ of foam ([ECHA 2017b](#)), which equates to an applied surface area of 40,733 m² based on an insulation thickness of 0.06

meters ([ECHA 2008b](#)). With this use volume, and assuming an average foam density of 40 kg/m³ based on the average of XPS density (35 kg/m³) and EPS density (45 kg/m³), and an HBCD content of approximately 1.35 wt% based on the average of HBCD concentration in XPS (2 wt%) and EPS (0.7 wt%) ([ECHA 2008b](#)), this results in a use rate by a professional contractor of 1,320 kg HBCD/job site. EPA assumed this HBCD use rate at large construction sites based on ECHA data is representative of large construction sites in the United States and uses this use rate for this Risk Evaluation. With this use rate of 1,320 kg HBCD/job site and a total construction use volume of 100,000 pounds/year (45,359 kg/year), EPA calculates 34 sites. EPA used 34 sites as the lower value in a range of the number of potential affected construction sites.

EPA also calculated the number of potential smaller residential construction sites by assuming a floor surface area of 2,169 ft² from U.S. Census Bureau data (<https://www.census.gov/const/C25Ann/sfttotalmedavgsgft.pdf>). EPA calculated the total applied surface area to be 519 m² and the total volume of insulation to be 31.2 m³, assuming a square house with one layer of insulation on three 10-foot tall stories (including basement and two above ground stories) and a foam thickness of 0.06 meters ([ECHA 2008b](#)). Using the same density and HBCD concentration as described above, EPA calculated a use rate of 16.82 kg HBCD/job site. With this use rate of 16.82 kg HBCD/job site and a total construction use volume of 45,359 kg/year, EPA calculates 2,696 sites. EPA uses 2,696 sites as the upper value in a range of the number of potential affected construction sites. EPA provides an estimated range of construction sites depending on the use of HBCD-containing XPS and EPS foam between commercial and residential sites.

Release Sources

Based on the process description, EPA infers that there are releases from sawing or thermal cutting of XPS or EPS foam and disposal of trimmings at construction sites. EPA does not expect dust generation during travel and unloading of the foam slabs at the construction sites ([OECD 2009](#)).

Emission Factors

The quantities of particles generated by cutting XPS and EPS foam were measured and are presented in Table 2-31 ([ECHA 2008b](#)). These data pertain to the methods of cutting of foam in the construction industry which are cutting with mechanical saws in the case XPS and EPS, and thermal cutting with hot wires or cutting with a knife and breaking in the case of EPS only. EPA estimated a particle generation factor for the thermal cutting with hot wires or cutting with a knife and breaking of XPS as described in Table 2-31.

The proportions of HBCD used for XPS and EPS are similar ([ECHA 2009b](#)). EPA assumes 50 percent of the HBCD processing volume is used to produce XPS and 50 percent is used to produce EPS. EPA calculated weighted emission factors for cutting and sawing of foam containing HBCD from the particle generation factors for XPS and EPS foams given in Table 2-31 and these shares of HBCD used in XPS and EPS. The calculated emission factors are given in Table 2-32.

Table 2-31. Particle Generation Factors Reported in the EURAR for Sawing or Cutting of XPS/EPS Foam Prior to Installation

Foam Type	Method of Cutting	Particle Generation Factor ^a
XPS boards	Sawing	5.0 g of XPS particles /metric ton XPS used ^b
XPS boards	Cutting with a knife and then breaking or hot wire cutting	1.12 g of XPS particles/metric ton XPS used ^c
EPS boards	Sawing	445 g of EPS particles/metric ton EPS used ^b
EPS boards	Cutting with a knife and then breaking or hot wire cutting	100 g of EPS particles/metric ton EPS used ^b

^a Quantity of particles generated per quantity of foam used assuming that only a tenth of the quantity used is cut and boards are 6 cm x 60 cm x 125 or 104 cm, and the boards are cut along the short side.

^b Measured values as reported in the EU RAR.

^c Calculated by EPA using the same ratio as that for EPS foam. Particle generation factor for cutting = 5.0 g XPS particles/metric ton XPS sawed x (100 g EPS particles/metric ton EPS cut ÷ 445 g EPS particles/metric ton EPS sawed) = 1.12 g XPS particles/metric ton XPS cut.

EU RAR estimated that one half of the generated particles are released to water while the other half are released to air. EPA assumes that all generated particles are released to air. EPA expects that construction sites are not likely to implement dust controls that would result in releases to stack air. EPA expects that dust releases are initially to fugitive air, with the possibility that the particles may settle and be discharged in wastewater to surface water or sewers (which lead to either surface water or POTWs). EPA does not expect that these dust releases will end up in landfills or be incinerated.

In addition to dust release, there may be release from disposal of scrap foam from cutting or sawing of the foam boards EPA uses the same emission factor for trimming of foam as described in Section 2.2.7.

Table 2-32. Summary of HBCD Release Sources During Installation of XPS/EPS Foam Insulation in Residential, Public, and Commercial Buildings, and Other Structures

Release Source	Emission factor used in this Risk Evaluation (kg HBCD released/kg HBCD processed)		Method of Release, Disposal, Treatment, or Discharge Assessed in this Risk Evaluation	Basis or Source
	Lower value of emission factors	Upper value of emission factors		
Dust generation from thermal cutting or sawing of XPS 10% of (50%) and EPS (50%) boards	5.06E-05	2.25E-04	Uncertain: Fugitive Air, surface water, and/or POTW	(ECHA 2008b)
Trimming disposal	0.01	0.025	Uncertain: Incineration and/or landfill ^a	(OECD 2009) (lower fraction); (U.S. EPA 2018d) (upper fraction)

Release Source	Emission factor used in this Risk Evaluation (kg HBCD released/kg HBCD processed)		Method of Release, Disposal, Treatment, or Discharge Assessed in this Risk Evaluation	Basis or Source
	Lower value of emission factors	Upper value of emission factors		
^a EPA assumed solid trimming waste disposal is to incineration and/or landfill.				

Number of Release Days

Based on the Draft Application of Spray Polyurethane Foam (SPF) generic Scenario ([U.S. EPA 2018d](#)), EPA estimated that workers install insulation over one day per residential job site and three days for commercial job sites. These estimates are based on the length of time for application of foam, the size of the building in which foam is installed, and judgment on additional time needed for set-up, tear-down, and maintenance activities at the job site.

The data sources used to estimate releases in this section are listed in Table 2-33 along with the data quality score. See Appendix D for more details about data source evaluation.

Table 2-33. Installation of XPS/EPS Foam Insulation in Residential, Public and Commercial Buildings, and Other Structures Release Data Source Evaluation

Source Reference	Data Type	Value	Overall Confidence Rating of Data
(ECHA 2008b)	Particle Generation Factor	See Table 2-31. Particle Generation Factors Reported in the EURAR for Sawing or Cutting of XPS/EPS Foam Prior to Installation	High

Environmental Release Assessment Results

The variables used for calculating releases with Equation 2-1 are summarized in Table 2-34.

Table 2-34. Input Variables to Equation 2-1 for the Installation of XPS/EPS Foam Insulation in Residential, Public and Commercial Buildings, and Other Structures

Input Variable					
V (of HBCD)	N _s (sites)		f (kg HBCD released/kg HBCD processed)		N _a (days/yr)
	Lower value (Commercial sites)	Upper value (Residential sites)	Lower value of emission factors (residential)	Upper value of emission factors (commercial)	
100,000 pounds/year = 45,359 kg/year (with 10% of boards assumed to be cut)	34	2,696	5.06E-05 to Fugitive Air, surface water, and/or POTW 0.01 to landfill and/or incineration	2.25E-04 to Fugitive Air; surface water, and/or POTW 0.025 to landfill and/or incineration	1 (residential) to 3 (commercial sites)

The daily amount of solid HBCD released per site from cutting of XPS and EPS foam at construction sites was calculated with Equation 2-1. The results of these calculations are summarized in Table 2-35.

EPA presents the lower and upper values of the range of release estimates calculated from varying the emission factors (lower and upper emission factors), number of sites (residential and commercial), and number of days per year (one day/year for residential sites and 3 days/year for commercial sites).

Strengths, Limitations, and Confidence in Assessment Results

EPA has medium to high confidence in the assessed range of daily release rates that are presented above. EPA considered the quality of the data, the assessment approach, and uncertainties in assessment results to determine the level of confidence.

As shown in Table 2-33, EPA used emission factor data from the EURAR with an overall confidence rating of high, which is a strength of the assessment..

The strength of the assessment approach is the estimation of HBCD emission factors, amount of HBCD per construction site and number of release days as ranges of values to account for variability in the values of these parameters that EPA obtained. Furthermore, the strength of the assessment approach is the estimation of the daily release of HBCD per site as a range of values which encompasses the range of parameters that EPA obtained.

The uncertainty of the assessment is the extent to which the emission factor data and the data on number of release days are applicable to the HBCD use activities that would occur in the U.S. Based on the strength and uncertainty of the assessment, EPA has medium to high confidence in the assessment results.

Table 2-35. Summary of HBCD Releases from Installation of XPS/EPS Foam Insulation in Residential, Public and Commercial Buildings, and Other Structures

Release Source	Method of Release, Disposal, Treatment, or Discharge ^a	Releases calculated from lower value of range of emission factors ^b					Releases calculated from upper value of range of emission factors ^b					Hours of Release per Day (hr/day)
		Total Annual Release for All Sites (kg/yr)	Annual Release Per Site (kg/site-yr)	Daily Release (kg/site-day)	Days of Release (day/year)	Number of Sites	Total Annual Release for All Sites (kg/yr)	Annual Release Per Site (kg/site-yr)	Daily Release (kg/site-day)	Days of Release (day/year)	Number of Sites	
Dust release during sawing / cutting of foam	May go to one or more: Fugitive Air, surface water, or POTW	2.3	8.5E-04	8.5E-04	1	2,696	10.2	0.30	0.10	3	34	8 hours/day
Trimming foam scrap	May go to one or more: Incineration or landfill	454	0.168	0.168	1	2,696	1134	33.4	11.1	3	34	8 hours/day

^a The method of release, disposal, treatment, or discharge may include some or all of those listed depending on site-specific conditions, including type of equipment use, size of the site, and waste handling practices, including any pollution controls used.

^b Release estimates are quantities of HBCD. The physical form of these releases is solid mixtures containing polystyrene and HBCD.

2.2.10 Demolition and Disposal of XPS/EPS Foam Insulation Products in Residential, Public and Commercial Buildings, and Other Structures

XPS and EPS foam insulation products are removed from buildings through demolition or remodeling of buildings. The demolition may be accomplished with many methods, including the use of explosives, a wrecking ball, or manual deconstruction ([ECHA 2008b](#)). EPA expects the demolition process is likely to involve the breaking of XPS and EPS foam insulation products into smaller pieces for subsequent recycling or disposal at construction and demolition waste landfills or waste to energy facilities.

Environmental Release Assessment Methodology

Total Volume of HBCD in the Buildings Demolished Annually

EPA estimated this volume as a fraction of the amount of HBCD in XPS and EPS currently in use in buildings of all types in the United States. The Environmental Health Strategy Center estimated that about 100 million pounds of HBCD existed in use in the “built environment” (EPA interprets this to mean in buildings of all types) in the United States as of 2010 (comment on Docket ID Number: EPA-HQ-OPPT-2016-0735-0008, ([Safer Chemicals 2017](#))). The number of houses of all types demolished between 2011-2013, including as a result of disaster, is equal to 0.36% of the number of houses present in 2011 ([HUD 2016](#)). Accordingly, EPA estimates 0.18% of houses are demolished annually. Also, more than one quarter of the buildings that existed in the year 2000 are expected to be replaced by the year 2030 in the U.S. ([U.S. EPA 2008b](#)). Therefore, the number of buildings demolished each year in the U.S. on average as a fraction of the total number of buildings that existed in the year 2000 is equal to 0.83%. EPA is uncertain whether buildings of all types, including small structures such as houses, are accounted for in the data obtained from U.S. EPA ([2008b](#)). Accordingly, EPA conservatively assessed the number of buildings of all types demolished each year in the U.S. as a fraction of the total number of existing buildings of all types to be equal to the sum of 0.18% and 0.83% or approximately 1%. Approximately 1.7% of the in-service volume of HBCD in Japan is disposed of each year ([Managaki et al. 2009](#)), but EPA did not use this data because it pertains to Japan and data pertaining to the U.S. is available as discussed above. In conclusion, 1% of the in-service volume of HBCD in the United States (100 million pounds) is estimated to be demolished each year. This results in one million pounds/year (~458,000 kg/year) as the total volume of HBCD in buildings demolished annually.

Number of Demolition Sites

EPA estimated the number of demolition sites to be proportional to the number of installation sites. As discussed in Section 2.2.9, EPA estimated a lower value of 34 commercial sites and an upper value of 2,696 residential sites for EPS or XPS foam insulation containing HBCD installed based on a processing volume of 100,000 pounds HBCD/year. Scaling for the larger demolition volume of one million pounds HBCD/year, EPA estimated a lower value of 343 commercial sites or an upper value of 27,230 residential sites with HBCD-containing insulation are demolished each year. The following is a sample calculation:

Low-end number of demolition sites = 34 installation sites X (1 million lbs of HBCD /100,000 lb/yr of HBCD) = 343 sites.

Release Sources

During demolition, releases are likely to occur from the generation of XPS and EPS particles resulting from the breaking of XPS and EPS insulation boards.

Emission Factors

XPS and EPS particle generation factors for cutting and/or manually breaking XPS and EPS boards are reported in the EU RAR or estimated by EPA. EPA estimated emission factors for releases from demolition as a range of values based on these various particle generation factors to account for various demolition methods as discussed below.

The quantities of particles generated by manually breaking XPS and EPS foam were measured and are presented in Table 2-36. Particle Generation Factors for the Demolition of XPS and EPS ([ECHA 2008b](#)). These factors were used in the EU RAR to assess releases from manual deconstruction of XPS and EPS boards for the purposes of recycling. For material demolished for disposal instead of recycling, the emission factor reported was 0.1% kg of HBCD released per kg of HBCD in EPS and XPS that is demolished ([ECHA 2008b](#)). EPA rated this emission factor as unacceptable with regard to systematic review overall confidence because the EU RAR did not include a reference for this value. To assess releases from demolition by means other than manual deconstruction, EPA assumed particle generation factors in the case of such demolition are equivalent to the particle generation factors for cutting with a knife and manually breaking that EPA used to assess releases from construction in the U.S. as discussed in Section 2.2.9. These particle generation factors pertain to cutting XPS and EPS with a hot wire or with a knife and manually breaking the boards, and are presented in Table 2-31. Particle Generation Factors Reported in the EURAR for Sawing or Cutting of XPS/EPS Foam Prior to Installation

The values given in Table 2-31 are based on the assumption that only 10% of XPS and EPS boards are sawed or cut. In contrast, EPA assumed that every board is affected during demolition and therefore multiplied these particle generation factors by 10. The adjusted particle generation factors are given in Table 2-36. Particle Generation Factors for the Demolition of XPS and EPS

Table 2-36. Particle Generation Factors for the Demolition of XPS and EPS

Method of Cutting	Type of Foam	Particle Generation Factor
Manual breaking	XPS boards	0 g of XPS particles/metric ton EPS broken ^a
	EPS boards	90 g of EPS particles/metric ton EPS broken ^a
Cutting with a knife and then manual breaking	XPS boards	11.2 g of EPS particles /metric ton XPS cut and broken ^b
	EPS boards	1000 g of XPS particles/metric ton XPS cut and broken ^b
^a Measured values that are used in the EU RAR to assess releases from manual deconstruction of XPS and EPS boards for the purpose of recycling. ^b These values were determined by multiplying the corresponding values in Table 2-31. Particle Generation Factors Reported in the EURAR for Sawing or Cutting of XPS/EPS Foam Prior to Installation by 10 to account for the breaking of every board.		

EPA used a weighted average of the XPS and EPS particle generation factors pertaining to manual breaking to calculate an emission factor for demolition by manual deconstruction. EPA also used a

weighted average of the XPS and EPS particle generation factors pertaining to cutting with a knife and manual breaking to calculate an emission factor for demolition by means other than manual deconstruction. EPA assumed the share of HBCD used in either XPS or EPS is 50% to calculate the weighted averages, and the rationale for this assumption is given in Section 2.2.9. These calculated emission factors are presented in Table 2-38. EPA assessed the emission factor for demolition as a range of values with these emission factors as the lower- and higher-end of this range.

Number of Release Days and Media of Release

EPA assumed that demolition at any site occurs during a single day and therefore releases occur during a single day. The size of the generated foam particles is not reported in the EU RAR and EPA assumed that all generated particles are sufficiently small to be emitted to ambient air initially. Dust controls at demolition sites are unlikely and EPA expects that dust generated during demolition is released to ambient air and may subsequently settle and be released in wastewater, surface water or sewers (which lead to either surface water or POTWs). EPA does not expect that these dust releases will end up in landfills or be incinerated.

The data sources used to estimate releases in this section are listed in Table 2-37 along with the data quality score. See Appendix D for more details about data source evaluation.

Table 2-37. Demolition of XPS/EPS Foam Insulation in Residential, Public and Commercial Buildings, and Other Structures Release Data Source Evaluation

Source Reference	Data Type	Value	Overall Confidence Rating of Data
(HUD 2016)	Fraction of houses of all types demolished	0.18%	High
(U.S. EPA 2008b)	Fraction of all buildings demolished	0.83%	High
(ECHA 2008b)	Particle Generation Factor	See Table 2-36	High

Environmental Release Assessment Results

The variables used for calculating releases with Equation 2-1 are summarized in Table 2-38.

Table 2-38. Summary of HBCD Releases from Demolition of XPS/EPS Foam Insulation in Residential, Public and Commercial Buildings, and Other Structures

V (of HBCD)	Input Variable				N _a (days/yr)
	N _s (sites)		F (kg HBCD released/kg HBCD processed)		
	Lower value (Commercial sites)	Upper value (Residential sites)	Lower value of emission factors	Upper value of emission factors	
1 million pounds/year = 458,128 kg/year	343	27,230	4.50E-05 to Fugitive Air, surface water, and/or POTW	5.06E-04 to Fugitive Air; surface water, and/or POTW	1

The amount of HBCD released from demolition was calculated with Equation 2-1. The results of these calculations are summarized in Table 2-39.

Table 2-39. Summary of HBCD Releases from Demolition of XPS/EPS Foam Insulation in Residential, Public and Commercial Buildings, and Other Structures

Release Source	Method of Release, Disposal, Treatment, or Discharge ^a	Releases calculated from lower value of range of emission factors ^b					Releases calculated from upper value of range of emission factors ^b					Hours of Release per Day (hr/day)
		Total Annual Release for All Sites (kg/yr)	Annual Release Per Site (kg/site-yr)	Daily Release (kg/site-day)	Days of Release (day/year)	Number of Sites	Total Annual Release for All Sites (kg/yr)	Annual Release Per Site (kg/site-yr)	Daily Release (kg/site-day)	Days of Release (day/year)	Number of Sites	
Generation of foam particles during demolition	May go to one or more: Fugitive Air, surface water, or POTW	20.6	7.57E-04	7.57E-04	1	27,230	232	0.675	0.675	1	343	8 hours/day

^a The method of release, disposal, treatment, or discharge may include some or all of those listed depending on site-specific conditions, including waste handling practices.

^b Release estimates are quantities of HBCD in particles of XPS and EPS.

Disposal of HBCD That is Part of Construction and Demolition Waste

Approximately 64 to 70% of construction and demolition (C&D) waste in the United States is disposed of in landfills and the remaining 30 to 36% is processed for reuse, recycling, or energy recovery (*e.g.*, at waste energy recovery incinerators) ([Townsend et al. 2019](#); [U.S. EPA 2018](#); [Tceq 2017](#)). The C&D waste that is disposed of in landfills is sent mainly to C&D landfills, but a portion is sent to municipal solid waste landfills ([U.S. EPA 1998](#); [U.S. EPA 2003](#)). The EPA Incident Waste Decision Support Tool (I-Waste DST) estimated that there were 1,577 C&D landfills in the United States in 2015 ([U.S. EPA 2015c](#)) and the Waste Business Journal estimated that there were 1,120 C&D landfills in the United States in 2019 ([Waste Business Journal, 2019](#)). There have historically been between 75 and 97 waste-to-energy facilities in the United States between 2001 and 2018 ([Energy Recovery 2018](#)) and there were 108 waste-to-energy facilities in the United States in 2019 ([Waste Business Journal, 2019](#)).

Strengths, Limitations, and Confidence in Assessment Results

EPA has medium confidence in the assessed range of daily release rates that are presented above. EPA considered the quality of the data, the assessment approach, and uncertainties in assessment results to determine the level of confidence.

EPA implemented this approach using emission factor data from the EURAR and estimated volume using HUD ([2016](#)) and U.S. EPA ([2008b](#)). The data from these sources both have overall confidence ratings of high, which is a strength of the assessment.

The strength of the assessment approach is the estimation of HBCD emission factors and amount of HBCD per demolition site as ranges of values to account for variability in the values of these two parameters that EPA obtained.

The uncertainty of the assessment is the extent to which the emission factor data and the data on demolition rate are applicable to the HBCD use activities that would occur in the U.S. In particular, the particle generation for demolition is expected to vary depending on the destructive method of demolition. There is uncertainty with the use of cutting of XPS/EPS foam particle generation factor as a

surrogate for the higher value emission factor for dust generation during demolition activities. Based on the strength and uncertainties of the assessment, EPA has medium confidence in the assessment results.

2.2.11 Processing: Recycling of EPS Foam and Reuse of XPS Foam

Schlummer et al. (2017) reported that XPS and EPS foam in construction insulation materials are rarely recycled for numerous reasons, including that insulation waste is typically not separated from mixed waste stream and most insulation containing HBCD is still in place.

To recycle EPS foam, the EPS boards are grinded, melted, and introduced into the EPS molding process with virgin EPS (ECHA 2008b). Thus, EPS recycling is likely to occur at sites with similar operations to those described for EPS foam manufacturing in Section 2.2.6. XPS insulation may be reused but is rarely recycled due to the specialized equipment needed to do so (U.S. EPA 2018f). Reuse of XPS may involve the cutting of the XPS insulation into different sizes, as needed. Based on reasonably available information, as discussed in the 2018 HBCD Problem Formulation Document, EPA assessed the reuse of XPS, but not the recycling of XPS (U.S. EPA 2018g).

Environmental Release Assessment Methodology

Facility Estimates

EPA identified two companies in the 2018 HBCD Problem Formulation Document that directly reuse (e.g., reuse without reforming) and recycle (e.g., melting and inserting into the manufacturing process) XPS and EPS foam insulation (U.S. EPA 2018g). One of these companies indicated that they recycle EPS roofing material at a rate of 10,000 pounds/year of EPS and reuse XPS roofing material at an unknown rate (but does not recycle it due the special equipment needed to recycle XPS). Details on the operations of the other recycling / reuse company were not provided (U.S. EPA 2018f), but EPA expects this company may perform both recycling and reuse of XPS and EPS foam.

EPA estimated releases for two EPS recycling and XPS reuse sites (one site) per company identified in the 2015 HBCD Problem Formulation document (U.S. EPA 2015a) for this exposure scenario) and uses the same known throughput (10,000 pounds of EPS insulation recycled per year) for both sites. EPA did not identify data to characterize the statistical representativeness of this assessment. With a typical HBCD concentration of 0.7 weight percent in EPS insulation (ECHA 2017c; INEOS Styrenics 2017; U.S. EPA 2015a; ECHA 2009a, 2008b; Thomsen et al. 2007), each company processes 70 pounds HBCD/year in EPS insulation (31.8 kg HBCD/site-year, or 63.5 kg HBCD/year for both sites).

One of the above companies estimates that 10-20% of EPS roofing material is recycled nationally (U.S. EPA 2018g), thus the number of sites that perform EPS recycling in the United States is likely greater than the two sites.

Release Sources

Based on the process description, EPA infers that releases for recycling of EPS foam for this exposure scenario are similar to those for Manufacturing of EPS Foam from Imported EPS Resin Beads, as described in Section 2.2.6, with the removal of the trimming release, as EPA does not expect that there will be waste disposal due to trimming at a EPS recycling site.

Emission Factors

EPA expects that EPS foam is likely to be transported in trucks or other bulk containers for this exposure scenario, as opposed to the transport of EPS resin beads in bags for the Manufacturing of EPS

Foam from Imported EPS Resin Beads. For this exposure scenario, EPA estimates releases from the cleaning of bulk containers used to transport the EPS foam to the converting site. The method of release, disposal, treatment, or discharge is dependent on any pollution controls that are implemented at that site, as well as other factors such as the equipment used and size of the site. The method of release, disposal, treatment, or discharge may include some or all of the following depending on site-specific conditions: surface water, POTW, onsite WWT, POTW, landfill, or incineration.

EPA additionally estimated releases from dust and equipment cleaning residue in accordance with the methodology described in Section 2.2.6 for the Manufacturing of EPS Foam from Imported EPS Resin Beads.

Number of Release Days

Using the European Communities Technical Guidance Document for industrial use in the polymers industry and a processing volume of 140 pounds HBCD/year (<1 metric ton), EPA estimated 1 day of emission per year ([ECB 2003](#)). Based on these data, EPA used a lower bounding estimate of one day/year, as the number of emission days cannot be lower than this estimate. Because EPS recycling may occur at similar sites as EPS foam manufacturing from EPS resin, EPA uses the same upper value of the range of days determined in Section 2.2.6, which is 140 days/year, which accounts for variability in the number of days a recycling facility may process HBCD containing EPS foam.

The data sources used to estimate releases in this section are listed in Table 2-40 along with the data quality score. See Appendix D for more details about data source evaluation.

Table 2-40. Recycling of EPS Foam Release Data Source Evaluation

Source Reference	Data Type	Value	Overall Confidence Rating of Data
(NICNAS 2012b)	Release Days	140 days/year for all releases	High
(ECB 2003)	Release Days	1 day/year for all releases	Medium

Environmental Release Assessment Results

The variables used for calculating releases with Equation 2-1 are summarized in Table 2-41. Input Variables to Equation 2-1 for the Recycling of EPS Foam

Table 2-41. Input Variables to Equation 2-1 for the Recycling of EPS Foam

Input Variable				
V (of HBCD)	Ns (sites)	f (kg HBCD released/kg HBCD processed)		Na (days/yr)
		Lower value of emission factors	Upper value of emission factors	
20,000 pounds of EPS foam/year = 140 pounds HBCD/yr (0.7% HBCD in foam) = 63.5 kg HBCD/year	2	Container cleaning: 0.01 to uncertain (could go to surface water, onsite WWT, POTW, landfill, and/or incineration)	Container cleaning: 0.01 to uncertain (could go to surface water, onsite WWT, POTW, landfill, and/or incineration)	1-140

		Equipment cleaning: 0.01 to uncertain (could go to surface water, onsite WWT/POTW, landfill, and/or incineration) Dust: 0.001 to uncertain (could go to stack air, fugitive air, surface water, onsite WWT, POTW, landfill, and/or incineration)	Equipment cleaning: 0.01 to uncertain (could go to surface water, onsite WWT/POTW, landfill, and/or incineration) Dust: 0.005 to uncertain (could go to stack air, fugitive air, surface water, onsite WWT, POTW, landfill, and/or incineration)	
--	--	---	---	--

The amount of solid HBCD released annually was calculated with Equation 2-1 by multiplying the processing volume of HBCD by the emission factors. The daily amount of HBCD released from recycling was calculated by dividing this annual release by the number of days of emission. The results of these calculations are summarized in Table 2-42.

Strengths, Limitations, and Confidence in Assessment Results

EPA has medium confidence in the assessed range of daily release rates that are presented above. EPA considered the quality of the data, the assessment approach, and uncertainties in assessment results to determine the level of confidence.

EPA used emission factor data from the 2009 OECD ESD on Plastic Additives and other EPA/OPPT models. The emission factor data were not evaluated because these data were obtained from an ESD or GS. EPA used data on the number of release days from the European Communities Technical Guidance Document ([ECB 2003](#)) and Australian risk assessment ([NICNAS 2012b](#)). The data from the technical guidance document has an overall confidence rating of medium and the data from the Australian risk assessment has an overall confidence rating of high; these ratings were assigned using EPA's systematic review process, as discussed in Section 1.5.

The strength of the assessment approach is the estimation of HBCD emission factors and number of release days as ranges of values to account for variability in the values of these two parameters that EPA obtained. Furthermore, the strength of the assessment approach is the estimation of the daily release of HBCD per site as a range of values which encompasses the range of emission factors and the number of release days that EPA obtained.

The uncertainty of the assessment is the extent to which the emission factor data and the data on number of release days are applicable to the HBCD recycling activities that would occur in the U.S. Based on the strength and uncertainty of the assessment, EPA has medium confidence in the assessment results.

Table 2-42. Summary of HBCD Releases from the Recycling of EPS Foam

Release Source	Method of Release, Disposal, Treatment, or discharge ^a	Releases calculated from lower value of range of emission factors ^b				Releases calculated from upper value of range of emission factors ^b				Number of Sites	Hours of Release per Day (hr/day)
		Total Annual Release for All Sites (kg/yr)	Annual Release Per Site (kg/site-yr)	Daily Release (kg/site-day)		Total Annual Release for All Sites (kg/yr)	Annual Release Per Site (kg/site-yr)	Daily Release (kg/site-day)			
				Number of release days: 1 day/year	Number of release days: 140 days/year			Number of release days: 1 day/year	Number of release days: 140 days/year		
Dust release from grinding of foam	May go to one or more: Stack air, Fugitive Air, surface water, onsite WWT, POTW, Landfill, or Incineration	6.35E-02	3.18E-02	3.18E-02	2.27E-04	0.318	0.159	0.159	1.13E-03	2	8 hours/day
Container cleaning residual	May go to one or more: surface water, onsite WWT, POTW, Landfill, or Incineration	1.270	0.635	0.635	4.54E-03	1.27	0.635	0.635	4.54E-03	2	8 hours/day

^a The method of release, disposal, treatment, or discharge may include some or all of those listed depending on site-specific conditions, including type of equipment use, size of the site, and waste handling practices, including any pollution controls used.

^b Release estimates are quantities of HBCD. The physical form of these releases is solid mixtures containing polystyrene and HBCD.

2.2.12 Formulation of Flux/Solder Pastes

EPA identified from the TRI data one site that processed HBCD as a formulation component. As discussed in Section 1.2, communication with this company indicates that this site formulates HBCD into flux/solder pastes. The TRI data does not specify the physical form of HBCD that is processed as a formulation component. Based on the process description below, EPA expects HBCD powder is likely used for this exposure scenario. This exposure scenario represents only the incorporation of HBCD into formulations of soldering materials.

In communication with EPA, the flux and solder paste formulation company explained that flux/solder paste components are processed in the U.S. and sent to China for final formulation and sale. The final solder flux formulations containing HBCD are sold to both international and U.S. customers who use the formulations primarily for electronics, such as circuit boards.

Incorporation into a formulation, mixture, or reaction product refers to the process of mixing or blending several raw materials to obtain a single product or preparation ([OECD 2010b](#)). First, the components of the product formulation are unloaded from transport containers, either directly into the mixing equipment or into an intermediate storage vessel ([OECD 2010b](#)). Transfer from transport containers may be manual or automated using a pumping system. An automated dispenser may be used to feed components into the mixing vessel to ensure that precise amounts are added at the proper time during the mixing process. Once in the mixing vessel, the components are then mixed in either a batch or continuous system. Depending on the specific product, the formulation may be further processed through filtering. Once the formulation is completed, it is sampled for quality control. The final formulation is then filled into containers, either through manual dispensing from transfer lines or through an automatic system. Automatic filling systems are generally used for the filling of smaller containers that are intended for consumer and commercial applications, whereas manual filling is done for larger containers (*e.g.*, tank trucks, totes, drums) which are typically used in an industrial setting ([OECD 2010b](#)).

Environmental Release Assessment Methodology

Facility Estimates

EPA expects that the amount of HBCD used in flux/solder paste is significantly less than the amount used for insulation in buildings, as these uses were not reported by the former manufacturers and importers of HBCD to the 2016 CDR. Use in EPS and XPS foam has accounted for 95 percent of all HBCD applications in the past decade ([U.S. EPA 2014d](#); [UNEP 2010a](#)). Due to lack of additional information, for the purposes of this Risk Evaluation, EPA estimated that the remaining five percent of HBCD applications are in solder flux formulations. With an importation volume equal to the CDR threshold of 100,000 pounds/year and 5 percent, EPA used a throughput of 5,000 pounds HBCD/year (2,268 kg/year) to estimate releases and exposures for this exposure scenario. Indium reported in 2017 to TRI that the maximum amount of HBCD on-site at any one point during the calendar year was between 1000 to 9,999 lbs. Indium increased the reported maximum amount of HBCD on-site to 10,000 to 99,000 lbs, but with overall reduced releases than 2017 TRI. Therefore EPA assessed the exposure scenario using 2017 TRI data. EPA assessed one solder formulation site based on TRI data ([U.S. EPA 2017g](#)).

Release Sources

Based on the process description, EPA infers releases may occur from dust generation during the transfer of HBCD powder from transport containers into blending vessels, residual HBCD in the

emptied transport containers from the direct disposal of the emptied containers, and the periodic cleaning of blending equipment.

Emission Factors

EPA estimated releases from this exposure scenario using release information reported by the solder/flux formulation site to the 2017 TRI. As indicated by the 2018 TRI data given in Section 1.2.4, the releases from this site during 2018 are much lower and therefore EPA assessed releases conservatively.

Number of Release Days

EPA estimated a range of emission days per year based on the European Communities Technical Guidance Document for formulation in the electronics industry, as the flux/solder formulations in this exposure scenario are used for electronics applications ([ECB 2003](#)). Specifically, EPA determined a range of potential emission days by calculating the lowest and highest possible emission days from the applicable defaults for formulation within the electronics industry. With this method and the HBCD processing volume for this exposure scenario (5,000 pounds or 2.25 metric tons), EPA estimated 5 days/year. The highest number of emission days for formulation within the electronics industry is 300 days/year. Based on this, EPA estimated a range of 5 to 300 emission days/year.

The data sources used to estimate releases in this section are listed in Table 2-43 along with the data quality score. See Appendix D for more details about data source evaluation.

Table 2-43. Formulation of Flux/Solder Pastes Release Data Source Evaluation

Source Reference	Data Type	Value	Overall Confidence Rating of Data
(U.S. EPA 2017g)	Site-Specific Release Quantities	See Table 2-44. Summary of HBCD Releases from Flux/Solder Paste Formulation Sites from 2017 TRI Data	Medium
(ECB 2003)	Release Days	5 to 300 days/year for all releases	Medium

Environmental Release Assessment Results

The releases, as they were reported to 2017 TRI, are summarized in Table 2-44. Summary of HBCD Releases from Flux/Solder Paste Formulation Sites from 2017 TRI Data

The flux/solder paste formulation site reports off-site transfers to a waste broker for disposal (disposal as defined at 40 CFR 372.3 is “any underground injection, placement in landfills/surface impoundments, land treatment, or other intentional land disposal”) and for treatment via solidification/stabilization (EPA assumes this disposal is to landfill).

Table 2-44. Summary of HBCD Releases from Flux/Solder Paste Formulation Sites from 2017 TRI Data

Site identity	Exposure scenario	2017 TRI		Hours of Release per Day (hr/day)	
		Annual Release Per Site (kg/site-yr)	Daily Release (kg/site-day) ^a		
			Over 5 day/year		Over 300 day/year
INDIUM CORP OF AMERICA, Clinton, NY	Formulation of Solder	Fugitive air ^a : 0.454 Stack air ^b : 6.350 Unknown disposal ^c : 0.454 Off-site landfill ^d : 6.350	Fugitive air ^a : 0.091 Stack air ^b : 1.27 Unknown disposal ^c : 0.091 Off-site landfill ^d : 1.27	Fugitive air ^a : 0.0015 Stack air ^b : 0.021 Unknown disposal ^c : 0.0015 Off-site landfill ^d : 0.021	8 hours/day

^a These fugitive air releases were reported under Section 5.1 of the TRI Form R, which correspond to on-site fugitive or non-point air emissions.

^b These stack air releases were reported under Section 5.2 of the TRI Form R, which correspond to on-site stack or point air emissions.

^c This unknown disposal quantity was reported under Section 6.2 of the TRI Form R, which corresponds to code M94, which is off-site transfer to waste broker for disposal. Disposal (as defined at 40 CFR 372.3) is 'any underground injection, placement in landfills/surface impoundments, land treatment, or other intentional land disposal'.

^d This off-site landfill quantity was reported under Section 6.2 of the TRI Form R, which corresponds to code M40, which is off-site transfer for treatment via solidification/stabilization. No additional details were provided. EPA assumes the final method of disposal is landfill.

Strengths, Limitations, and Confidence in Assessment Results

EPA has medium confidence in the assessed range of daily release rates that are presented above. EPA considered the quality of the data, the assessment approach, and uncertainties in assessment results to determine the level of confidence.

EPA used release data from 2017 TRI data, which has an overall confidence rating of medium, assigned using EPA's systematic review process, as discussed in Section 1.5. EPA used data on number of release days from the European Communities Technical Guidance Document ([ECB 2003](#)), which has an overall confidence rating of medium.

The strength of the assessment approach is the estimation of number of release days and daily release of HBCD as ranges of values to account for potential variability in the release days associated with the annual release amounts.

The uncertainty of the assessment is the extent to which the annual release data is reflective of the full distribution of release rates and the extent to which the data on number of release days are applicable to the HBCD processing activities that would occur in the U.S. Based on the strengths and uncertainty of the assessment, EPA has medium confidence in the assessment results.

2.2.13 Use of Flux/Solder Pastes

As described in Section 1.2.5.3, EPA identified that HBCD is used specifically in solder/flux pastes that are used in electronics manufacturing. The solder/flux paste formulator indicated that the final formulations are used both overseas for electronics manufacturing and domestically. EPA did not find information on the fraction of the solder/flux pastes that are used domestically. EPA assumes that the entire amount is used in the United States. Additionally, for the purpose of this Risk Evaluation, EPA assumes that they are used similarly as they are used overseas, specifically in electronics manufacturing.

Within the electronics industry, solder/flux pastes are used to attach components to printed circuit boards. EPA expects that the use of solder in other industries involve similar release sources and quantities as those assessed in this Risk Evaluation.

Solder pastes are comprised of solder, which is a metal alloy, predominantly tin mixed with other metals such as lead and silver, suspended within flux pastes that typically contains rosin, wetting agents, viscosity modifiers, and other fluxing aids ([OECD 2010a](#)). Soldering is a process in which two or more substrates, or parts (usually metal), are joined together by melting solder paste into the joint and allowing it to cool, thereby joining the independent parts. Solder paste is first applied in the area between the substrates to be joined, then heat is applied to the solder paste, which causes the solder to melt and join the two substrates together once cooled. The solder has a lower melting point than the adjoining metal substrates, allowing it to be melted during the soldering process without melting the substrates. The function of flux within the solder paste is to prevent oxidation during the soldering process, which ensures that soldered joints are secure ([OECD 2010a](#)). Soldering differs from welding in that soldering does not involve melting the substrates being joined.

Solder paste can be applied to metal substrates with a variety of methods. The website of the site that processes HBCD as a formulation component, identified from TRI, depicts solder paste formulations as syringe/bead applied to circuits to be soldered. Based on this information, EPA expects the use of syringe application on circuit boards during this exposure scenario.

Solder pastes are largely made up of metal solder (at least 90 percent), flux (around 5 percent), with the remainder as solvent and other additives (these specialty chemicals are generally less than one percent of the composition of the solder paste) ([OECD 2010a](#)). HBCD serves as a fluxing aid within solder/flux paste formulations.

Environmental Release Assessment Methodology

Facility Estimates

As discussed in Section 2.2.12, EPA estimated a throughput of 5,000 pounds HBCD/year (2,268 kg/year) for the formulation of solder flux. EPA uses this same HBCD volume for this exposure scenario. EPA estimated that the entire throughput is used in the United States, as the portion that is used internationally is unknown, as discussed above.

EPA uses the OECD ESD on Chemicals Used in the Electronics Industry ([OECD 2010a](#)). To calculate the number of solder use sites as described below. Since the OECD ESD estimates other additives are generally less than one percent of the composition of the solder paste, EPA used an HBCD composition of one weight percent for this exposure scenario.

The OECD ESD includes default annual facility use rates for non-aqueous (paste) solder paste formulations of less than 1,000 kg/site-year for small scale use sites and greater than 1,000 kg/site-year for large scale use sites. To calculate the number of sites for this exposure scenario, EPA uses a throughput of 1,000 kg solder formulation/site-year. The number of sites is equal to the HBCD use volume (2,268 kg/year), divided by the solder paste formulation use rate (1,000 kg/site-year) and HBCD content in the formulation (0.01). This calculation results in 227 sites.

Release Sources

Based on information in the OECD ESD, EPA infers that releases may occur from: disposal of containers used to ship the flux/solder paste formulations containing HBCD, cleaning of soldering equipment and soldered components, and overapplied solder ([OECD 2010a](#)).

EPA estimated releases from this exposure scenario using the 2010 OECD ESD on Chemicals used in the Electronics Industry ([OECD 2010a](#)), as the formulator of the solder and flux pastes containing HBCD indicates that these formulations are used for circuits and other electrical components. Table 2-45 summarizes the release sources assessed by EPA. The methodology used for this assessment is explained below.

Emission Factors

The OECD ESD on Chemicals Used in the Electronics Industry indicates that the total loss from use of flux and solder in the electronics industry is typically 10 percent ([OECD 2010a](#)). The OECD ESD specifies that releases contributing to this overall loss may include washing of equipment used for soldering, washing of components that have been soldered, and from disposal of unused solder by either solvent washings that occur throughout the electronics manufacturing process or disposal of scrap components containing solder formulations.

While the OECD ESD does not specifically call out releases from disposal of containers used to ship the flux and solder paste formulations, EPA expects this release is a part of the total 10 percent loss estimated by the OECD ESD. The website of the flux and solder formulator identified in TRI indicates that these formulations are frequently supplied in small containers, such as syringes, from which application onto substrates may be conducted directly from the containers, without unloading into separate application equipment. EPA expects that these containers are most likely disposed of as solid waste to landfill or treated via incineration, as opposed to being cleaned (which may result in liquid wastes). Thus, EPA estimated release from container residual disposed of to landfill or treated via incineration, using the *EPA/OPPT Small Container Residual Model*, which indicates a loss of 0.6 percent from residue inside containers ([U.S. EPA 2013a](#)). The method of release, disposal, treatment, or discharge is dependent on any pollution controls that are implemented at that site, as well as other factors such as the equipment used and size of the site. EPA did not find information on waste handling procedures at these sites. The method of release, disposal, treatment, or discharge may include disposal to landfill, treatment via incineration, or both.

The OECD ESD on Chemicals Used in the Electronics Industry indicates that release may occur from cleaning of equipment or components (such as solder equipment, which is distinguished from application equipment) ([OECD 2010a](#)). The OECD ESD estimates that this release is up to 2 percent of the use volume discharged in wastewater to on-site WWT or POTW.

The final release that is defined in the OECD ESD is loss of unused flux and solder paste formulations. This may occur when unused formulation on soldered components (*i.e.*, overapplied solder) is washed off components in some of the solvent washings that are customary in the electronics manufacturing process ([OECD 2010a](#)). This release may also occur from the disposal of scrap components that have been soldered or that contain unused flux and solder formulation. While the OECD ESD does not specify an exact loss percentage for this release, it does estimate a total loss of 10 percent, which EPA used to determine this release fraction by subtracting the upstream losses of container disposal (0.6%) and equipment cleaning (1 to 2%). Thus, EPA estimated a loss of 7.4 to 8.4 percent for this release. The OECD ESD indicates that generated process solvents are disposed of as hazardous waste (which EPA

assumes includes incineration or hazardous waste landfill disposal) and that scrap components are disposed of as solid waste. Thus, EPA assessed disposal to landfill or treatment via incineration. The method of release, disposal, treatment, or discharge is dependent on any pollution controls that are implemented at that site, as well as other factors such as the equipment used and size of the site. EPA did not identify information on waste handling procedures at these sites. The method of release, disposal, treatment, or discharge may include disposal to landfill, treatment via incineration, or both.

The total loss from this exposure scenario is 10% per the OECD ESD, with variation in the amount of release for each method of release, disposal, treatment, or discharge (wastewater, landfill, or incineration).

Table 2-45. Summary of HBCD Release Sources During Use of Flux and Solder Pastes

Release Source	Emission Factor used in this Risk Evaluation	Method of Release, Disposal, Treatment, or Discharge Assessed in this Risk Evaluation	Basis or Source
Disposal of used transport container containing solid HBCD residuals	0.006 kg HBCD released/kg HBCD in containers	Uncertain: landfill, incineration Due to the small container size (syringes), EPA assumes containers are disposed of from the sites as solid waste to either landfill or incineration	<i>EPA/OPPT Small Container Residual Model (U.S. EPA 2013a)</i>
Equipment Cleaning release of solid HBCD residuals	0.01 to 0.02 kg HBCD released/kg HBCD used	100% to Onsite WWT/POTW	(OECD 2010a). – The OECD ESD indicates that up to 2% of total releases may be to wastewater from cleaning of equipment or components.
Unused flux remaining on components, which are likely removed in subsequent solvent washes	0.084 to 0.074 (10% minus upstream losses, see above) kg HBCD released/kg HBCD used	Uncertain: landfill, incineration Solvent washings treated as hazardous waste. EPA assessed to incineration or landfill.	(OECD 2010a). – Per the OECD ESD a total of 10% loss is expected; accounting for upstream losses, this loss is 7.4%

Number of Release Days

EPA estimated a range of emission days per year based on the European Communities Technical Guidance Document for use in the electronics industry, as the solder formulations in this exposure scenario are used for electronics applications (ECB 2003). Specifically, EPA determined a range of potential emission days by calculating the lowest and highest possible emission days from the applicable defaults for use within the electronics industry. With this method and the HBCD processing volume for this exposure scenario (5,000 pounds or 2.25 metric tons), EPA estimated 4 days/year. The highest number of emission days for use within the electronics industry is 300 days/year. Based on these values, EPA estimated a range of 4 to 300 emission days/year.

The data sources used to estimate releases in this section are listed in Table 2-46 along with the data quality score. See Appendix D for more details about data source evaluation.

Table 2-46. Use of Flux and Solder Pastes Release Data Source Evaluation

Source Reference	Data Type	Value	Overall Confidence Rating of Data
(ECB 2003)	Release Days	4 to 300 days/year for all releases	Medium

Environmental Release Assessment Results

The variables used for calculating releases with Equation 2-1 are summarized in Table 2-47

Table 2-47. Input Variables to Equation 2-1 for Use of Flux and Solder Pastes

Input Variable				
V (kg HBCD imported/yr)	Ns (sites)	f (kg HBCD released/kg HBCD used)		Na (days/yr)
		Lower values of emission factors	Upper values of emission factors	
5,000 pounds/yr = 2,268 kg/yr	227	0.09 to landfill and/or incineration	0.08 to landfill and/or incineration	4-300
		0.01 to Onsite WWT and/or POTW	0.02 to Onsite WWT and/or POTW	

The amount of solid HBCD released from use of flux and solder pastes was calculated with Equation 2-1. The results of these calculations are summarized in Table 2-48. The use of flux and solder pastes results in releases to wastewater, municipal landfill, and incineration. The largest source of release is from unused formulations that are disposed of to landfill or incineration.

Strengths, Limitations, and Confidence in Assessment Results

EPA has medium confidence in the assessed range of daily release rates that are presented above. EPA considered the quality of the data, assessment approach, and uncertainties in assessment results to determine the level of confidence.

EPA used emission factor data from the 2010 OECD ESD on Chemicals Used in the Electronics Industry. The quality of the emission factor data was not evaluated because this data was obtained from an ESD. EPA used data on number of release days from the European Communities Technical Guidance Document ([ECB 2003](#)), which has an overall confidence rating of medium, assigned using EPA's systematic review process, as discussed in Section 1.5.

The strength of the assessment approach is the estimation of HBCD emission factors and number of release days as ranges of values to account for variability in the values of these two parameters that EPA obtained. Furthermore, the strength of the assessment approach is the estimation of the daily release of HBCD per site as a range of values which encompasses the range of emission factors and the number of release days that EPA obtained.

The uncertainty of the assessment is the extent to which the emission factor data and the data on number of release days are applicable to the HBCD use activities that would occur in the U.S. Based on the strength and uncertainty of the assessment, EPA has medium confidence in the assessment results.

Table 2-48. Summary of HBCD Releases from Use of Flux and Solder Pastes

Release Source	Method of Release, Disposal, Treatment, or Discharge ^a	Higher landfill and incineration releases ^b				Higher onsite wastewater, POTW releases ^b				Number of Sites	Hours of Release per Day (hr/day)
		Total Annual Release for All Sites (kg/yr)	Annual Release Per Site (kg/site-yr)	Daily Release (kg/site-day)		Total Annual Release for All Sites (kg/yr)	Annual Release Per Site (kg/site-yr)	Daily Release (kg/site-day)			
				Number of release days: 4 day/year	Number of release days: 300 day/year			Number of release days: 4 day/year	Number of release days: 300 day/year		
Equipment cleaning release of solid HBCD residuals	May go to one or more: Onsite WWT or POTW	22.7	0.100	2.50E-02	3.33E-04	45.4	0.200	5.00E-02	6.66E-04	227	8 hours/day
Disposal of transport containers containing solid HBCD residual and overapplied/unused solder	May go to one or more: Incineration or landfill	204	0.899	2.25E-01	3.00E-03	181	0.799	0.200	2.66E-03	227	8 hours/day

^a The method of release, disposal, treatment, or discharge may include some or all of those listed depending on site-specific conditions, including type of equipment use, size of the site, and waste handling practices, including any pollution controls used.

^b Release estimates are quantities of HBCD. The physical form of these releases is solid or paste mixtures containing HBCD and other solder / flux formulation components.

2.2.14 Recycling of Electronics Waste (E-Waste) Containing HIPS

HBCD was used in the production of HIPS, which can be found in television sets, computers, phones, and other electronic products (Morf et al. 2005). EPA estimated HBCD releases from e-waste recycling sites to be equal to the following values as discussed below:

- central tendency estimate: 0.008 to 0.024 kg/day-site;
- high-end estimate: 0.12 to 0.38 kg/day-site.

EPA is uncertain of the media of release and hence assesses these rates as rates of releases to air or landfill or incineration or to some combination of these methods of release, disposal, or treatment methods.

EPA calculated the HBCD release rates in accordance with the following equations:

Equation 2-2: HBCD release rate from an e-waste recycling Site

$$R = X \times (V_y \div N_d) \times \sum f_i$$

Equation 2-3: average recycling rate of consumer electronics per e-waste recycling site

$$V_y = V_t \div N_s$$

Equation 2-4: total number of e-waste recycling sites

$$N_s = N_{sc} \times \alpha$$

Where:

- R = the amount of HBCD released per day from an e-waste recycling site to the environment or to disposal or treatment (kg per day per site)
- X = the amount of HBCD contained in recycled consumer electronics (kg HBCD per kg of recycled electronics)
- V_y = annual recycling rate of consumer electronics per site (kg of recycled electronics per year per site)
- N_d = the number of HBCD release days per year from a site (days per year)
- f_i = emission factor for release of HBCD to the environment or to disposal or treatment from a particular source at an e-waste recycling site (kg of HBCD released per kg of HBCD contained in the recycled electronics)
- V_t = annual recycling rate of consumer electronics in the U.S. (kg of recycled electronics per year)
- N_s = the total number of e-waste recycling sites in the U.S. (sites)
- N_{sc} = the number of certified e-waste recycling sites in the U.S. (sites)
- α = the ratio of total number of e-waste recycling sites and number of certified e-waste recycling sites

EPA calculated the central tendency and high-end HBCD releases rates from central tendency and high-end values of the annual recycling rate of consumer electronics per site (V_y), respectively. To account for measurement error in the values of the amount of HBCD contained in recycled consumer electronics (X) and the values of the various emission factors for release of HBCD to the environment or to disposal or treatment (f_i), EPA calculated each of the central tendency and the high-end release rates as a range of values. The values of the input variables of Equation 2-2, Equation 2-3, and Equation 2-4, that EPA chose, references for these values and the overall confidence rating of these values is presented in Table 2-49.

EPA determined the values of the input variables of Equation 2-2, Equation 2-3, and Equation 2-4, as follows:

1. The Amount of HBCD Contained In Recycled Consumer Electronics, HBCD Emission Factors, Environmental Media of Release and Treatment and Disposal Methods:

Morf et al. (2005) prepared a mass balance of HBCD in a “modern state-of-the-art” waste electrical and electronic equipment (WEEE) recycling facility located in Switzerland. They accomplished this by measuring (a) the mass of WEEE fed to the facility, (b) the masses of the output streams, and (c) the concentrations of HBCD in all relevant output streams of the facility. They calculated the mass of HBCD per kg of the recycled WEEE on average, including the parts of the WEEE that are not flame retarded, to be equal to 17 ± 4 mg of HBCD/kg of WEEE. The WEEE fed to the facility consisted of “small household appliances (*e.g.*, toasters and vacuum cleaners), office and communication appliances (*e.g.*, personal computers and monitors, printers, phones, and fax and photocopy machines), entertainment electronics (*e.g.*, television (TV) sets, videos, camcorders, radios, HiFis, and portable compact disk (CD players), and small size electrical and electronic (E&E) equipment (*e.g.*, plugs and mobile phones).”

Morf et al. (2005) reported the ratio of the mass of HBCD in an output steam to the mass of HBCD in the WEEE feed to the facility. These mass ratios and the output steams associated with them are as follows: the fine-grained plastic fractions ($0.574 \pm 18\%$), plastics and wooded castings (PC/TV) ($0.277 \pm 81\%$), fine-grained metal fractions ($0.074 \pm 24\%$), dust collected in bag filters ($0.04 \pm 44\%$), Cu cables ($0.025 \pm 45\%$), printed circuit boards ($0.010 \pm 25\%$) and air emitted from these bag filters (0.002%). EPA’s assessment is that the HBCD contained in the following output streams is released to the environment or to disposal or treatment: the dust collected in bag filters, the air emitted from the bag filters, and the fine-grained metal fractions. EPA’s rationale for assessing the release, disposal or treatment of the HBCD in the fine-grained metal fractions is that e-waste recycling in the U.S. may include metal extraction (NIOSH 2014a) and this output stream contains plastic impurities (Morf et al. 2005) which may be separated and/or emitted during the processing of this output steam for the purpose of metal extraction.

EPA’s expectation is that waste streams comprising solid material in filters are disposed of in landfills or treated via incineration. Also, there may be significant releases to the environment from e-waste recycling processes that do not include efficient air pollution control devices (Morf et al. 2005). Hence, EPA’s assessment conservatively is that the dust collected in bag filters, and the fine-grained metal fractions are released to air, to landfill or to incineration or to some combination of this environmental medium or disposal or treatment methods. EPA expects that releases to water directly from e-waste recycling sites is unlikely. At the vast majority of sites surveyed by NIOSH, e-waste is disassembled and separated (NIOSH 2014b), and these processes do not include aqueous process streams. For example, the facility examined by Morf et al. (2005) does not include aqueous process streams. Cleaning of equipment with water between batches is unlikely because contamination is not a problem. Cleaning surfaces such as floors to remove settled dust is done by vacuuming or compressed air (NIOSH 2014b) or dry brushing (Rosenberg et al. 2011) although wet mopping and wet brushing are superior to the use of compressed air or dry brushing as cleaning methods for industrial hygiene reasons (NIOSH 2014b; Rosenberg et al. 2011).

2. Consumer Electronics Recycling Rates:

The annual recycling rate of selected consumer electronics during 2015 in the U.S. was equal to $1,230 \times 10^3$ U.S. tons (U.S. EPA 2019o). Selected consumer electronics “includes products such as TVs, VCRs, DVD players, video cameras, stereo systems, telephones and computer equipment.” EPA selected the value pertaining to the year 2015 because this is largest reported value. The number of

certified e-waste recycling facilities in the U.S. was 550 during 2015 ([U.S. EPA 2016a](#)). Currently there are 716 certified sites and 29 non-certified sites ([e-Steward 2020](#); [Sustainable Electronics Recycling 2020](#)), and EPA calculated α , or the ratio of total number of e-waste recycling sites and number of certified e-waste recycling sites, from these values. The capacity of a state-of-the-art WEEE recycling facility in Switzerland is 30,000 metric tons per year ([Morf et al. 2005](#)) and the capacity of a state-of-the-art e-waste recycling facility in Canada is also 30,000 metric tons per year ([Tomko and McDonald 2013](#)). Accordingly, EPA assumed the high-end value of the rate of recycle of consumer electronics per site in the U.S. to be equal to 30,000 metric tons/year. EPA assumes that an e-waste recycling facility is operates 5 days a week and is shutdown a total of two weeks during the year for maintenance and hence estimate the number of operating days to be 250 days/year.

Strengths, Limitations, and Confidence in Assessment Results

EPA has medium confidence in the assessed release rates presented above. EPA considered the quality of the data, the assessment approach, and uncertainties in assessment results to determine the level of confidence.

The result of EPA's systematic review is data with an overall confidence rating of medium or high, which is a strength of the assessment.

The strength of the assessment approach is the estimation of releases based on measurements of HBCD concentrations in e-waste recycling output streams.

There is uncertainty in the assessed HBCD release rates because the HBCD concentration data, which pertain to a facility in Switzerland, and the maximum annual e-waste recycling rate per site, which pertains to Switzerland and Canada, may not represent data that pertain to e-waste recycling facilities in the U.S.

Table 2-49. Values, References for, and Overall Confidence Ratings of Input Variables of Equations HBCD Release Rate from E-Waste Recycling Sites

Input Variables of Equation 2-2, Equation 2-3, and Equation 2-4	Values of Input Variables			Reference	Overall Confidence Rating
	Value Chosen to Calculate the Central Tendency Release Rate	Value Chosen to Calculate the High-End Release Rate	Values Chosen for Calculating the Central Tendency and High-End Release Rates as a Range of Values		
X	17 ± 4 mg of HBCD / kg of recycled electronics		low-end of range: 21 mg HBCD/kg of recycled electronics high-end of range: 13 mg HBCD/kg of recycled electronics	(Morf et al. 2005)	medium
V _y	This parameter was calculated from the values for V _t and N _{sc} and α given below in accordance with Equation 2-3, and Equation 2-4.	30,000 metric tons/year	not applicable	(Tomko and Mcdonald 2013 ; Morf et al. 2005)	medium, high
N _d	250 days/year		value assumed by EPA	not applicable	not applicable
f (dust in bag filter)	0.04 ± 44% kg HBCD/kg HBCD		low-end of range: 0.0224 kg HBCD/kg HBCD high-end of range: 0.0576 kg HBCD/kg HBCD	(Morf et al. 2005)	medium
f (air emitted from bag filter)	0.00002 kg HBCD/kg HBCD		not applicable		
f (fine grain metal fractions)	0.074 ± 24% kg HBCD/kg HBCD		low-end of range: 0.0562 kg HBCD/kg HBCD high-end of range: 0.0918 kg HBCD/kg HBCD		
V _t	1,230 x10 ³ US tons in 2015	not applicable	not applicable		
N _{sc}	550 sites in 2015	not applicable	not applicable	(U.S. EPA 2016a)	high
α	1.04 (calculated by EPA from the current number of certified and non-certified sites)	not applicable	not applicable	(e-Steward 2020 ; Sustainable Electronics Recycling 2020)	medium

2.2.15 Sensitivity Analysis - Process Volume

In Section 2.2.2 through Section 2.2.7, EPA provided release estimates using the CDR reporting threshold volume of 100,000 lbs/yr-site. EPA selected 100,000 lbs/yr as a conservative process volume in an effort to account for the uncertainty in the current HBCD import volume. As discussed in Section 1.2.3, EPA determined that the previously high volume HBCD importers (as identified by the 2016 CDR) have permanently stopped importing HBCD. EPA's review of a widely used import database (Datamyne) identified 5 companies in 2016 importing a total of 399,315 kg/yr (880,339 lbs/yr) of HBCD, and 1 company importing 46,096 kg/yr (101,624 lbs) in 2017. The 101,624 lbs of import in 2017 were from one consignee in two equal shipments of 23,048 kgs (50,812 lbs). The import of HBCD has been steadily declining since the United Nations Stockholm Convention on Persistent Organic Pollutants (POPs) has caused many processors to shift to alternative flame retardants. Due to the uncertainty with the imported volume, EPA performed a targeted sensitivity analysis of process volume for select exposure scenarios.

EPA performed the sensitivity analyses for three exposure scenarios at process volumes per site of 50,000 lbs/yr and 25,000 lbs/yr to examine the effect of process volume on environmental releases and the resulting general population and environmental exposures. EPA selected 50,000 lbs/yr based on the imported volume reported in one shipment for HBCD (2017), and to account for the declining use of HBCD, EPA also considered a lower volume of 25,000 lbs/yr. The exposure scenarios considered in the sensitivity analysis represent the exposure scenarios that resulted in the highest estimates of releases on a daily basis and include scenarios that rely on both industry data and OECD ESDs. As shown in equation 2.1, the daily releases of HBCD are estimated based on four parameters: process volume (V), number of sites (N_s), emission factor (f), and number of release days (N_d). The last parameter, number of release days (N_d), was estimated by either using industry data, days provided in relevant ESDs/GSs or European Communities Technical Guidance Document ([ECB 2003](#)). Depending on the source, the selected range of release days may vary based on the expected process volume and was adjusted accordingly. The determination of release days for each exposure scenario is discussed in their respective sections: Section 2.2.2, Section 2.2.4, and Section 2.2.6. For all of the selected exposure scenarios, the estimated total annual release per site decreased by the same factor as the decrease in the process volume (*i.e.*, annual releases based on 50,000 lbs/yr decreased by a factor of 2; annual releases based 25,000 lbs/yr decreased by a factor of 4).

Repackaging of Import Containers

For repackaging of import containers, quantities of releases are estimated from dust emissions during the transfer of HBCD powder from import containers into new containers and from residual HBCD in the emptied import containers that are disposed of. The quantities of releases at the different process volumes are presented in Table 2-50. Summary of HBCD Releases from Sensitivity Analysis of Repackaging of Import Containers

An explanation of the emission factors for this exposure scenario are presented in Section 2.2.2. The daily quantities of releases into the environment at different process volumes are relatively unchanged as the range of the daily throughput volume (process volume /site- day) for this exposure scenario did not significantly change. The lower value of the number of release days (*i.e.*, operating days for this exposure scenario) were estimated using B-tables from the basic chemicals industry category in the European Communities Technical Guidance Document ([ECB 2003](#)), which calculates a number of release days using the total import volume of the chemical substance. The changes in process volumes

adjust proportionally the number of release days, the effect was similar daily releases. EPA also deemed that the higher value of release days, 300 days, should be adjusted to stay within a reasonable range of daily throughputs based on the expected repackaging process and the reported daily throughput given by a repackaging site ([NICNAS 2012b](#)).

Processing to Produce XPS Foam from XPS Masterbatch

For the manufacturing of XPS foam from XPS Masterbatch, releases are estimated from: dust generation during unloading the HBCD powder from the bags in which they were received; disposal of the bags in which the HBCD powder is received; and periodic cleaning of process equipment. An explanation of the emission factors for this exposure scenario are presented in Section 2.2.4. The releases at the different process volumes are presented in Table 2-51. The decrease in daily releases into the environment between process volume is directly proportional to the decrease in the process volume. The release days specified by site-specific emission data in the EURAR are used for the range of release days.

Processing to Produce EPS Foam from EPS resins

For Manufacturing of EPS foam from EPS resins, releases are estimated from dust generation during unloading the EPS resin beads from the bags in which they were received and from the converting process; disposal of the bags in which the EPS resin beads are received; and periodic cleaning of process equipment. An explanation of the emission factors for this exposure scenario are presented in Section 2.2.6. The releases at the different process volumes are presented in Table 2-52. The changes in daily release into the environment varies depending on the estimated number of release days For the lower value of release days that were generated using the EU TGD- Polymer Industry ([ECB 2003](#)), the adjustment to the release days was proportional to the decrease in process volume. This resulted in little change for the calculated daily releases at the lower value of release days. The higher value of release days was reported by a EPS foam manufacturer ([NICNAS 2012b](#)). The process volume of the reported site was not included, so it is uncertain if the lower process volume is applicable to the reported release days. However, EPA believes given the small percentage of HBCD in EPS resins beads (<1%), 140 days is still within a reasonable range of release days for EPS foam manufacturing for both 50,000 lbs/yr and 25,000 lbs/yr of HBCD.

Table 2-50. Summary of HBCD Releases from Sensitivity Analysis of Repackaging of Import Containers

Release Source	Method of Release, Disposal, Treatment, or Discharge ^a	Releases calculated from lower value of range of emission factors ^b			Releases calculated from upper value of range of emission factors ^b		
		Annual Release Per Site (kg/site-yr) ^c	Daily Release (kg/site-day)		Annual Release Per Site (kg/site-yr) ^c	Daily Release (kg/site-day)	
			Lower Number of release days ^d	Upper Number of release days ^e		Lower Number of release days ^d	Upper Number of release days ^e
Annual import volume = 100,000 pounds HBCD/year							
Dust release during unloading of HBCD	May go to one or more: Stack air, Fugitive Air, on-site WWT, POTW, landfill, or incineration	45.4	1.56	0.15	227	7.82	0.756
Disposal of transport bags	Landfill	454	15.64	1.51	454	15.64	1.51
Annual import volume = 50,000 pounds HBCD/year							
Dust release during unloading of HBCD	May go to one or more: Stack air, Fugitive Air, on-site WWT, POTW, landfill, Incineration	22.7	1.51	0.15	113	7.56	0.756
Disposal of transport bags	Landfill	227	15.12	1.51	227	15.12	1.51
Annual import volume = 25,000 pounds HBCD/year							
Dust release during unloading of HBCD	May go to one or more: Stack air, Fugitive Air, on-site WWT, POTW, landfill, Incineration	11.3	1.62	0.15	57	8.10	0.756
Disposal of transport bags	Landfill	113	16.20	1.51	113	16.20	1.51

^a The method of release, disposal, treatment, or discharge may include some or all of those listed depending on site-specific conditions, including type of equipment use, size of the site, and waste handling practices, including any pollution controls used.

^b Release estimates are quantities of HBCD. The physical form of these releases is solid HBCD.

^c Based on the assumption of one given site.

^d The lower number of release days is 29 days/yr (100,000 lb/yr), 15 days/yr (50,000 lb/yr), 7 days/yr (25,000 lb/yr). Release days were calculated using the new process volume using EU TGD B-tables ([ECB 2003](#)), which required rounding to the nearest integer for release days. While the process volumes were scaled by 2, due to rounding, the daily releases are not directly scaled by the same factor.

^e The upper number of release days is 300 days/yr (100,000 lb/yr), 150 days/yr (50,000 lb/yr), 75 days/yr (25,000 lb/yr).

Table 2-51. Summary of HBCD Releases from Sensitivity Analysis of XPS Foam Manufacturing Using XPS Masterbatch

Release Source	Method of Release, Disposal, Treatment, or Discharge ^a	Releases calculated from lower value of range of emission factors ^b			Releases calculated from upper value of range of emission factors ^b		
		Annual Release Per Site (kg/site-yr) ^c	Daily Release (kg/site-day)		Annual Release Per Site (kg/site-yr) ^c	Daily Release (kg/site-day)	
			Lower Number of release days ^d	Upper Number of release days ^e		Lower Number of release days ^d	Upper Number of release days ^e
Annual import volume = 100,000 pounds HBCD/year							
Unknown – these data were reported by EU sites in the EURAR as total annual release per site	May go to one or more: Stack air or fugitive air	2.63	2.63	0.164	2.63	2.63	0.164
Unknown – these data were reported by EU sites in the EURAR as total annual release per site	May go to one or more: Surface Water, Onsite WWT, or POTW	0.486	0.486	3.24E-02	1.19	1.19	0.080
Annual import volume = 50,000 pounds HBCD/year							
Unknown - these data were reported by EU sites in the EURAR as total annual release per site	May go to one or more: Stack air, fugitive air	1.31	1.31	0.082	1.31	1.31	0.082
Unknown - these data were reported by EU sites in the EURAR as total annual release per site	May go to one or more: Surface Water, Onsite WWT, POTW	0.243	0.243	1.62E-02	0.60	0.60	0.040
Annual import volume = 25,000 pounds HBCD/year							
Unknown - these data were reported by EU sites in the EURAR as total annual release per site	May go to one or more: Stack air, fugitive air	0.66	0.66	0.041	0.66	0.66	0.041
Unknown - these data were reported by EU sites in the EURAR as total annual release per site	May go to one or more: Surface Water, Onsite WWT, POTW	0.121	0.121	8.10E-03	0.30	0.30	0.020
^a The method of release, disposal, treatment, or discharge may include some or all of those listed depending on site-specific conditions, including type of equipment use, size of the site, and waste handling practices, including any pollution controls used.							
^b Release estimates are quantities of HBCD. The physical form of these releases is solid mixtures containing polystyrene and HBCD.							
^c Based on the assumption of one given site.							
^d The lower number of release days is 1 day/year (for all releases and all annual import volumes).							
^e The upper number of release days is 15 day/year (wastewater discharges) and 16 day/year (air releases) for all annual import volumes.							

Table 2-52. Summary of HBCD Releases from Sensitivity Analysis of EPS Foam Manufacturing from EPS Resin Beads

Release Source	Method of Release, Disposal, Treatment, or Discharge ^a	Releases calculated from lower value of range of emission factors ^b			Releases calculated from upper value of range of emission factors ^b		
		Annual Release Per Site (kg/site-yr) ^c	Daily Release (kg/site-day)		Annual Release Per Site (kg/site-yr) ^c	Daily Release (kg/site-day)	
			Lower Number of release days ^d	Upper Number of release days ^e		Lower Number of release days ^d	Upper Number of release days ^e
Annual import volume = 100,000 pounds HBCD/year							
Dust release during converting process	May go to one or more: Stack air, Fugitive Air, surface water, onsite WWT, POTW, Landfill, or Incineration	45.4	2.83	0.324	227	14.17	1.62
Equipment cleaning	May go to one or more: surface water, onsite WWT, POTW, landfill, or Incineration	454	28.3	3.24	454	28.3	3.24
Disposal of transport containers	Landfill	454	28.3	3.24	454	28.3	3.24
Trimming foam scrap	May go to one or more: Incineration or landfill	454	28.35	3.24	1134	70.87	8.10
Annual import volume = 50,000 pounds HBCD/year							
Dust release during converting process	May go to one or more: Stack air, Fugitive Air, surface water, onsite WWT, POTW, Landfill, Incineration	22.7	2.83	0.162	113	14.17	0.81
Equipment cleaning	May go to one or more: surface water, onsite WWT, POTW, landfill, Incineration	227	28.3	1.62	227	28.3	1.62
Disposal of transport containers	Landfill	227	28.3	1.62	227	28.3	1.62
Trimming foam scrap	May go to one or more: Incineration; landfill	227	28.35	1.62	567	70.87	4.05
Annual import volume = 25,000 pounds HBCD/year							
Dust release during converting process	May go to one or more: Stack air, Fugitive Air, surface water, onsite WWT, POTW, Landfill, Incineration	11.3	2.83	0.081	57	14.17	0.40
Equipment cleaning	May go to one or more: surface water, onsite WWT, POTW, landfill, Incineration	113	28.3	0.81	113	28.3	0.81
Disposal of transport containers	Landfill	113	28.3	0.81	113	28.3	0.81
Trimming foam scrap	May go to one or more: Incineration; landfill	113	28.35	0.81	283	70.87	2.02

^a The method of release, disposal, treatment, or discharge may include some or all of those listed depending on site-specific conditions, including type of equipment use, size of the site, and waste handling practices, including any pollution controls used.

^b Release estimates are quantities of HBCD. The physical form of these releases is solid mixtures containing polystyrene and HBCD.

^c Based on the assumption of one given site.

^d The lower number of release days is 16 days/yr (100,000 lb/yr), 8 days/yr (50,000 lb/yr), 4 days/yr (25,000 lb/yr).

Release Source	Method of Release, Disposal, Treatment, or Discharge ^a	Releases calculated from lower value of range of emission factors ^b			Releases calculated from upper value of range of emission factors ^b		
		Annual Release Per Site (kg/site-yr) ^c	Daily Release (kg/site-day)		Annual Release Per Site (kg/site-yr) ^c	Daily Release (kg/site-day)	
			Lower Number of release days ^d	Upper Number of release days ^e		Lower Number of release days ^d	Upper Number of release days ^e
^e The upper number of release days is 140 days/year (all annual import volumes).							

2.2.16 Assumptions and Key Sources of Uncertainties for Environmental Releases

Processing Volume and Number of Sites

This evaluation estimates a processing volume and number of sites for each exposure scenario of HBCD based on information provided by industry, information from literature or assumes maximum import volume set at the CDR reporting threshold. For the exposure scenarios involving processing of HBCD into XPS and EPS foam (discussed in Section 2.2.2 through Section 2.2.7), EPA utilizes a processing volume of up to 100,000 pounds per year for an unknown site as discussed in Section 2.2.1. There are uncertainties with the number of possible small firms currently importing HBCD and their import volumes. This could lead to an overestimation of total annual releases at any given site, if HBCD is imported, processed, or used at a lower volume. The impact of the processing volume on daily releases can vary with site-specific variables such as the number of batches (if it's not a continuous process), the frequency of cleaning or the number of release days also influencing daily releases rates. EPA evaluated the exposure scenarios related to XPS and EPS foam manufacturing only at 100,000 pounds per year, however, EPA used a range of release days and emission factors to develop a reasonable range of daily releases to the environment.

For the use of XPS and EPS foam as insulation building materials, EPA used the total HBCD import volume of 100,000 pounds for all sites that install XPS and EPS foam insulation (Sections 2.2.9). As discussed above, there is uncertainty as to the number of small firms importing HBCD and their import volumes, which leads to uncertainty in the overall volume of HBCD that may be used for XPS and EPS foam insulation in buildings. To determine the number of sites that install XPS and EPS foam in buildings, EPA used XPS and EPS foam properties (*i.e.*, density, thickness, and HBCD concentration in the foam) and assumed building sizes to calculate an HBCD throughput at each construction site, from which the number of sites could be determined. For this HBCD throughput calculation, EPA used averaged foam properties between XPS and EPS foam insulation. However, these properties may vary depending on the type of insulation (*i.e.*, interior wall, exterior wall, or roofing), which results in uncertainty in this throughput and number of sites estimates. In addition, EPA used assumed building sizes for residential and commercial sites to develop lower and upper estimates of HBCD throughput and number of sites. The actual building size and associated HBCD throughput is expected to vary widely, resulting in additional uncertainty in this estimate. The lower and upper estimates of HBCD throughput and number of sites may underestimate and overestimate releases, respectively. However, EPA developed these upper and lower estimates in an effort to capture the possible range of number of sites and associated releases. For demolition and disposal of XPS/EPS foam insulation (Section 2.2.10), EPA used the same assumptions to estimate number of demolition sites based on volume information on the amount of HBCD in the built environment.

For the recycling of EPS foam (Section 2.2.11), EPA estimated HBCD processing volume and number of sites based on information identified from industry in the HBCD Problem Formulation ([U.S. EPA 2018g](#)). There is uncertainty in the extent to which this information captures the full number of sites that recycle or reuse XPS/EPS building insulation containing HBCD. This could lead to underestimation of total annual releases for all sites for this exposure scenario; however, EPA believes the estimates of releases on a per site basis are reasonable because the HBCD processing volume per site is based on industry data.

For the use of flux/solder pastes containing HBCD (Section 2.2.13), EPA assumed that 5% of 100,000 pounds of HBCD was used for this exposure scenario based on historical data that indicated 95% or more of HBCD is used in building insulation. As described above, the use of 100,000 pounds is a source of uncertainty. In addition, there is uncertainty as to whether this historical proportion is still reflective

of the current usage of HBCD in United States. Using this total HBCD volume, EPA calculated the number of sites and processing volume at each site using the 2010 OECD ESD on Chemicals Used in the Electronics Industries ([OECD 2010a](#)). The basis of these calculations is an assumed solder paste throughput (and associated HBCD content) reported in the OECD ESD to distinguish small scale from large scale sites that conduct soldering. The solder throughput and HBCD content likely vary between sites and the use rate in the United States may differ from that reported in the OECD ESD. A major electronics site may utilize more HBCD-containing flux/solder paste than the assumed solder paste throughput, which could lead to an underestimation of releases at the site. The uncertainties in these estimates may result in either underestimation or overestimation of releases on a total and per site basis.

EPA did not estimate the number of sites for the installation of automobile replacement parts (Section 2.2.8). EPA used 2017 TRI data to estimate the number of sites and associated releases for the formulation of HBCD into solder/flux pastes (Section 2.2.12), rather than estimating these values.

Emission Factors

This report uses existing release data from 2017 TRI data, the EURAR, or modeling approaches from relevant ESDs or GSs to estimate emission factors during each exposure scenario. For certain exposure scenarios (Section 2.2.3 through Section 2.2.5), discrete HBCD release quantities provided in the EURAR were used; however, the EURAR did not provide HBCD throughput (*i.e.*, HBCD processing volumes) for the specific sites from which emission factors could be calculated. The EURAR only provided combined HBCD processing volumes for all the sites for which release data were available. EPA calculated emission factors from EURAR data by dividing the total annual HBCD release quantities for all sites by the total HBCD processing volume for all sites. There is uncertainty from using the total HBCD release quantities and total HBCD throughput to calculate emission factors, as this does not account for variability in the actual HBCD throughput at the site (higher or lower), which would result in different emission factors for each site.

In some instances, EPA used the reported emission factors in the EURAR. Although EPA expects that activities described in risk assessments performed by the EURAR are similar to those performed in the United States, EPA could not verify these values. In particular, uncertainty arises from the geographic origin of the release data. The data reported in the EURAR pertains to HBCD releases at sites in Europe and the extent to which this data is applicable to HBCD releases in the U.S. is uncertain. There is also uncertainty about the extent to which the release data in the EURAR is applicable to the evaluated exposure scenarios in this Risk Evaluation. Despite potential differences in practices of the European sites from which data was collected in the EURAR and sites in the United States, these data have an overall confidence rating of High from the systematic review process.

In cases where there was no release data in the EURAR for the exposure scenario in this risk assessment, EPA used modeling approaches from relevant ESDs or GSs, specifically the 2009 OECD ESD on Plastic Additives, and the 2010 OECD ESD on Chemicals Used in the Electronics Industry. While these ESDs or GSs are applicable to the industries of the exposure scenarios, they are not necessarily specific to the use of HBCD within these industries. In some cases, OECD ESDs or GSs use modeling approaches listed in EPA ChemSTEER User Guide ([U.S. EPA 2013a](#)). Although there is no statistical characterization of the emission factors from these models, EPA believes the emission factors are in the upper end of the distribution based on EPA's experience. For dust releases in Sections 2.2.2, 2.2.6, and 2.2.11, EPA used emission factors from the 2009 OECD ESD on Plastic Additives, which provides two discrete emission factors, one for particulates <40 µm and one for particles >40 µm. EPA

expects a distribution of particle sizes and associated emission factors but does not have these data. The use of the two discrete emission factors from the ESD is a source of uncertainty.

Release Days

EPA estimated the number of release days using industry data from the EURAR, information from ESDs or GSs, and from the European Communities Technical Guidance Document ([ECB 2003](#)). Where available, EPA used the number of release days reported in the EURAR for sites with specific release data. The EURAR did not report site-specific HBCD processing volume from which EPA could scale these release days to account for HBCD throughput at the sites. There is uncertainty in the extent to which the HBCD throughput and HBCD processing activities and frequency is similar to that assessed by EPA. EPA also estimated release days using GSs and ESDs. There is uncertainty whether the GSs and ESDs are reflective of the sites and operations that are included in this Risk Evaluation. As stated earlier, while ESDs or GSs are applicable to the industries of the exposure scenarios, they are not necessarily specific to the use of HBCD within these industries. EPA evaluated potential environmental releases using a range of release days in an effort to address the uncertainty and variability in release days.

Additionally, EPA estimated release days from the European Communities Technical Guidance Document ([ECB 2003](#)). There is uncertainty in the applicability of this methodology for HBCD use in the United States. However, EPA evaluated potential environmental releases using a range of release days in an effort to address the large variability in release days.

2.3 Environmental Exposures

2.3.1 Approach and Methodology

HBCD has been detected in a wide variety of environmental and biological media, as expected based on its environmental fate properties such as high persistence in soil, surface water, and groundwater, and its bioaccumulation and bioconcentration tendencies. This environmental exposure assessment focuses on HBCD concentrations in surface water, sediment, and soil, as these are the media which were evaluated to determine risks to aquatic (pelagic and benthic) and terrestrial organisms (refer to Section 3 and Section 4 on hazard and risk characterization, respectively). Ambient air was only assessed for its contribution via deposition to these media. Levels in wildlife were examined, but were not brought forward to the environmental risk estimation due to the incompatibility of the hazard and wildlife biomonitoring data available, as will be explained in Section 4.

Releases from industrial facilities, indoor sources (building materials and dust), and long-range transport all contribute to levels in the environment. However, source attribution and temporal trends from these disparate sources is complex. As such, EPA used two main approaches to estimate environmental exposures. A non-scenario specific approach was used to estimate environmental exposures based on media concentrations not related to a specific COU release estimate; whereas, a scenario specific approach was used to estimate environmental exposures that are based specifically on the COU release estimates. The non-scenario specific approach is generally more applicable to background or away from facility estimates, but may also be used to represent exposures in industrial areas that contain facilities relevant to the COUs or other facilities. The approaches used a variety of data types as appropriate, including:

- 1) Monitoring data: Measured concentrations from the analysis of primary source monitoring data (direct use of monitoring data),
- 2) Modeling data: Predicted concentrations from EPA modeling (modeling data), and/or
- 3) Concentrations from the interpretation or scaling of monitoring or modeled data (*i.e.*, use of meta-analysis results, scaling of modeling work by others, etc.).

A summary of the approaches is provided in Table 2-53 and described further below.

Non-Scenario Specific Approach

For the non-scenario specific exposure approach, EPA screened, evaluated, and extracted monitoring data for surface water, sediment, soil, and targeted wildlife biota. All studies with available monitoring data and passing evaluation scores were considered for determining environmental concentrations and overall trends. EPA characterized the data by proximity to industrial facilities based on contextualizing information provided in the data source. Sampling locations described as industrial, downstream of a facility, or in proximity of a facility were characterized as “near facility” (or point source). All remaining data, often with sampling locations described as background, urban, suburban, or rural, were characterized as “away from facility” (or non-point source). Characterization based on distance between the sampling location and industrial facility or source attribution is typically not feasible for open source literature studies because they generally do not provide this information. Additionally, studies do not always provide the industrial sector of the nearby industrial facilities, which would help to further characterize the source of HBCD. While primary source monitoring data is the preferred data type for the non-scenario specific approach, EPA also evaluated monitoring and modeling data provided in completed assessments.

For the non-scenario specific approach, EPA carried forward for risk estimation an overall central tendency concentration and high-end concentration for near facility and away from facility datasets. Since only limited U.S. data was identified through systematic review, data from the U.S. as well as other high-income countries as classified by the World Bank (June 2019) were included in the final analysis (<https://datahelpdesk.worldbank.org/knowledgebase/articles/906519-world-bank-country-and-lending-groups>). High-income countries were selected as surrogate countries based on the assumption that these countries have manufacturing, processing, and use characteristics that are most likely to resemble those in the United States. A description of the statistical approach to estimating the central and high-end concentrations can be found in *Risk Evaluation for Cyclic Aliphatic Bromide Cluster (HBCD), Supplemental Information on General Population, Environmental, and Consumer Exposure Assessment* ([U.S. EPA 2019d](#)). In short, EPA estimated an arithmetic mean and 90th percentile value for each dataset based on its distribution type (lognormal or normal), and from these values calculated an overall central tendency (mean of means) and high-end value (average of 90th percentile). The distribution type was determined from the type and combination of statistical parameters available in the study (*i.e.*, geometric mean, arithmetic mean, median, geometric standard deviation, standard deviation, minimum, and/or maximum). Most combinations were assigned a lognormal distribution type, unless mean estimates were outside the range of reported data. A normal distribution type was assigned to datasets with only a mean and standard deviation or when the mean and medians were the same. Datasets were excluded from the final analysis dataset when not enough parameters were available to estimate a mean or 90th percentile (*i.e.*, only a range of values or only a minimum or maximum value was reported). The *Risk Evaluation for Cyclic Aliphatic Bromide Cluster (HBCD), Supplemental Information on General Population, Environmental, and Consumer Exposure Assessment* ([U.S. EPA 2019d](#)) also contains charts that summarize all extracted data and tables with metadata (number of

samples, country, location type, sample years, detection limit, detection frequency, and the data evaluation score).

Scenario Specific Approach

For the scenario specific exposure approach, no monitoring data specific to U.S. facilities that manufacture, process, and/or dispose of HBCD related to the conditions of use being assessed were identified. Therefore, EPA relied on modeling potential releases from facilities using release information discussed in Section 2.2. The models used in this assessment include: the Exposure Fate Assessment and Screening Tool (E-FAST), the Variable Volume Water Model Point Source Calculator (VVWM-PSC), and the Integrated Indoor-Outdoor Air Calculator (IIOAC). A tiered modeling approach was implemented for surface water concentrations. E-FAST, a simple dilution based model, was first used to estimate total chemical surface water concentrations in streams. As E-FAST does not consider chemical partitioning into various media due to a physico-chemical properties (Kow, Koc), it tends to over-estimate total surface water concentrations and under-estimate the chemical concentration that is sorbed to soil. Since HBCD's physico-chemical properties lends it to potentially partitioning into various media (Section 2.1), E-FAST-derived exposures that were greater than the most conservative environmental- or human health- relevant PoD were triaged for further modeling using the VVWM-PSC model which incorporates partitioning and degradation. The VVWM-PSC model was also used to estimate settled sediment in the benthic region of streams. As discussed in Section 2.3.6, a sensitivity analysis was conducted on select inputs used in the aquatic modeling. Finally, EPA used IIOAC to estimate air deposition from facility releases, and calculate resulting soil concentrations near the facilities. IIOAC uses pre-run results from a suite of AERMOD dispersion scenarios at a variety of meteorological and land-use settings, as well as release emissions, to estimate particle deposition at different distances from sources that release chemical substances to the air. For contextual purposes only, the IIOAC deposition results were applied to a generic farm pond setting to calculate concentrations of HBCD in pond surface water and pond sediment.

For the scenario specific approach, EPA carried forward to risk determination all surface water and sediment concentrations calculated using VVWM-PSC (second tier model), as well as surface water concentrations from scenarios modeled in E-FAST (first tier model) that were not triaged for further modeling in VVWM-PSC.

Table 2-53. Overview of Approaches Used in HBCD Environmental Exposure Assessment

	Non-Scenario Specific	Scenario Specific
Primary Data Type	<ul style="list-style-type: none"> Monitoring 	<ul style="list-style-type: none"> Modeling
Characterization	<ul style="list-style-type: none"> Near industrial facility (point source) or away from industrial facility (non-point source) Not specific to a COU 	<ul style="list-style-type: none"> Near industrial facility (point source) Specific to COUs
Facility Estimates/Releases	<ul style="list-style-type: none"> Not applicable 	<ul style="list-style-type: none"> COU specific (refer to Section 2.2). Releases were not modeled for a specific facility, rather hypothetical subscenarios with in each COU.
Variability	<ul style="list-style-type: none"> Central and high-end values 	<ul style="list-style-type: none"> Lower and upper of days of release/yr and emission factors, and different release media types (refer to Section 2.2)
Surface Water	<ul style="list-style-type: none"> Direct use of monitoring data (near and away from facility) 	<ul style="list-style-type: none"> Modeling of water releases to rivers (Tiered approach using E-FAST and VVWM-PSC)

Media Specific Data Types		<ul style="list-style-type: none"> Modeling data from completed assessment (near and away from facility) 	<ul style="list-style-type: none"> Modeling of air deposition to ponds (IIOAC) (contextual purposes only)
	Sediment	<ul style="list-style-type: none"> Direct use of monitoring data (near and away from facility) Modeling data from completed assessment (near and away from facility) Meta-analysis of monitoring data in completed assessments 	<ul style="list-style-type: none"> Modeling of water releases to rivers (VVWM-PSC) Modeling of air deposition to ponds (IIOAC) (contextual purposes only)
	Soil ^a	<ul style="list-style-type: none"> Background: Direct use of monitoring data Biosolids: Interpretation of monitoring and model data 	<ul style="list-style-type: none"> Modeling of air deposition to soil (IIOAC)
	Wildlife ^b	<ul style="list-style-type: none"> Direct use of monitoring data Meta-analysis of monitoring data in completed assessments 	<ul style="list-style-type: none"> Not applicable

^a For soil, the background soil and biosolid soil concentrations were combined with air deposition to soil concentrations for an overall soil concentration value.

^b For wildlife, concentrations were not brought forward to risk estimation.

Water and Air Release Condition of Use Subscenarios for Scenario-Specific Approach

Modeling was conducted by EPA for conditions of use with water and/or air releases, assuming a conservative process volume of 100,000 pounds/year/site based on the CDR reporting threshold (Section 2.2.1) for exposure scenarios 1 through 6. Lower, more refined facility estimates were used for exposure scenarios 8 through 12. Up to twelve sub-scenarios per each exposure scenario were created to describe the range of potential exposure by combining the different identified release types (surface water, on-site WWT and/or POTW for water releases; stack, fugitive and/or incineration for air releases) with upper and lower limits (if available) of the number of days of release and emission factors.

Table 2-54 summarizes the water release subscenarios that were used in the E-FAST and VVWM-PSC models and Table 2-55 summarizes the air release subscenarios that were used in the IIOAC model. Detailed subscenario tables are provided in Appendix E.

Table 2-54. Summary of Subscenarios Used Across Conditions of Use for Water Releases of HBCD

Water Scenarios	COU	Type of Water Release ^{a,b}	Facility Estimate (lb/site/yr)	Emission Factor ^c	Number of Release Days ^d	Range of Daily Release (kg/site/day)
W1.1 to W1.8	1. Repackaging of Import Containers	On-site, POTW	100,000	Low: 0.001 High: 0.005	Low: 29 High: 300	1.5E-01 to 7.8E+00
W2.1 to W2.12	2. Compounding of Polystyrene Resin to Produce XPS Masterbatch	Surface Water, On-site, POTW	100,000	Low: 3.22E-05 High: 7.42E-05	Low: 10 High: 60	2.4E-02 to 3.4E-01
W3.1 to W3.12	3. Manufacturing of XPS Foam using XPS Masterbatch	Surface Water, On-site, POTW	100,000	Low: 1.08E-05 High: 2.63E-05	Low: 1 High: 15	3.2E-02 to 1.2E+00
W4.1 to W4.6	4. Manufacturing of XPS Foam using HBCD Powder	Surface Water, On-site, POTW	100,000	Average: 1.02E-05	Low: 1 High: 12	3.9E-02 to 4.6E-01

Water Scenarios	COU	Type of Water Release ^{a,b}	Facility Estimate (lb/site/yr)	Emission Factor ^c	Number of Release Days ^d	Range of Daily Release (kg/site/day)
W5.1 to W5.12	5. Manufacturing of EPS Foam from Imported EPS Resin beads	Surface Water, On-site, POTW	100,000	Low: 0.011 (combined) High: 0.015 (combined)	Low: 16 High: 140	3.6E+00 to 4.2E+01
W6.1 to W6.12	6. Manufacturing of SIPs and Automobile Replacement Parts	Surface Water, On-site, POTW	100,000	Low: 5.06E-05 High: 2.25E-04	Low: 16 High: 300	7.6E-03 to 6.4E-01
W8.1 to W8.4	8. Installation of Insulation in Buildings	Surface Water, POTW	Residential: 37; Commercial: 2,941	Low: 5.06E-05 High: 2.25E-04	Low: 1 High: 3	8.5E-04 to 1.0E-01
W9.1 to W9.4	9. Generation of foam particles during demolition	Surface Water, POTW	Low: 37 High: 2,945	Low: 4.5E-05 High: 5.06E-04	1	7.57E-04 to 0.675
W10.1 to W10.12	10. Recycling of EPS Foam	Surface Water, On-site, POTW	70	Low: 0.021 (combined) High: 0.025 (combined)	Low: 1 High: 140	4.8E-03 to 7.9E-01
W12.1 to W12.8	12. Use of Solder	On-site, POTW	22	Low: 0.01 High: 0.02	Low: 4 High: 300	3.3E-04 to 5.0E-02

^a For each release source, water releases were modeled depending on the potential for the release to go directly to surface water [Surface Water], to on-site wastewater treatment [On-site], and/or to publicly owned treatment works [POTW]. The type of release influences two modeling input parameters: 1) Stream flow (million liters per day) and 2) wastewater removal rates (%). For surface water and on-site WWT release types, the E-FAST default stream flow of "POTW All" was assigned to COU 8 and the default stream flow of "Plastic Resins" was assigned for all other COUs. For POTW release types, the E-FAST stream flow default for "Industrial POTWs" was used.

^b A water removal rate of 90% was applied to the on-site WWT and POTW releases and no treatment was assumed for surface water.

^c Where identified in literature, EPA utilized a low and high emission factor, with the characterization of those emission factor described in further details in Section 2.2. If multiple emission factors were identified for the same type of release media the emission factors were combined.

^d Where identified in literature, EPA utilized a range of release days based on the specific condition of use as discussed further in Section 2.2.

Table 2-55. Summary of Scenarios Used Across Conditions of Use for Air Releases of HBCD

Air Scenarios	COU	Type of Air Release	Facility Estimate (lb/site/yr)	Emission Factor	Number of Release Days	Range of Daily Release (kg/site/day)
A1.1 to A1.12	1. Import/Repackaging	Fugitive, Stack, Incineration	100,000	Low: 0.001 High: 0.005	Low: 29 High: 300	1.5E-01 to 7.8E+00
A2.1 to A2.8	2. Compounding of Polystyrene Resin to Produce XPS Masterbatch	Fugitive, Stack	100,000	Low: 6.12E-06 High: 7.31E-06	Low: 10 High: 60	4.6E-03 to 3.3E-02
A3.1 to A3.4	3. Manufacturing of XPS Foam using XPS Masterbatch	Fugitive, Stack	100,000	Low: 5.79E-05 High: 5.80E-05	Low: 1 High: 16	1.6E-01 to 2.6E+00
A4.1 to A4.12	4. Manufacturing of XPS Foam using HBCD Powder	Fugitive, Stack, Incineration	100,000	Average: 7.29E-06	Low: 1 High: 16	2.1E-02 to 2.3E+01

Air Scenarios	COU	Type of Air Release	Facility Estimate (lb/site/yr)	Emission Factor	Number of Release Days	Range of Daily Release (kg/site/day)
A5.1 to A5.12	5. Manufacturing of EPS Foam from Imported EPS Resin beads	Fugitive, Stack, Incineration	100,000	Low: 0.021 (combined) High: 0.04 (combined)	Low: 16 High: 140	3.2E-01 to 1.1E+02
A6.1 to A6.12	6. Manufacturing of SIPs and Automobile Replacement Parts	Fugitive, Stack, Incineration	100,000	Low: 5.06E-05 High: 2.25E-04	Low: 16 High: 300	7.6E-03 to 7.2E+01
A8.1 to A8.4	8. Installation of Insulation in Buildings	Fugitive, Incineration	Residential: 37; Commercial: 2,941;	Low: 5.06E-05 High: 2.25E-04	Low: 1 High: 3	8.5E-04 to 1.1E+01
W9.1 to 9.2	9. Generation of foam particles during demolition	Fugitive	Low: 37 High: 2,945	4.5E-05	1	7.57E-04 to 0.675
A10.1 to A10.12	10. Recycling of EPS Foam	Fugitive, Stack, Incineration	70	Low: 0.021 (combined) High: 0.025 (combined)	Low: 1 High: 140	2.3E-04 to 7.9E-01
A11.1 to A11.4	11. Formulation of solder	Fugitive, Stack	d	d	Low: 5 High: 300	1.5E-03 to 1.3E+00
A12.1 to A12.4	12. Use of Solder	Incineration	22	Low: 0.08 (combined) High: 0.09 (combined)	Low: 4 High: 300	2.7E-03 to 2.2E-01

^a For each release source, air releases were modeled depending on whether the releases were from fugitive, stack or incineration emissions.

^b Where identified in literature, EPA utilized a range of emission factors with the characterization of those emission factor described in further details in Section 2.2.

^c Where identified in literature, EPA utilized a range of release days based on the specific condition of use as discussed further in Section 2.2.

^d Daily release estimates were based on releases reported to 2017 TRI

2.3.2 Aquatic Environment - Surface Water and Sediment

2.3.2.1 Non-Scenario Specific Approach

The non-scenario specific approach uses measured media-specific monitoring data to characterize background exposure to HBCD where releases attributed to historical and current conditions of use may be encompassed. As described below in Section 2.3.2.2, all exposure scenarios with surface water releases have predicted surface water and sediment HBCD concentrations, except for land disposal of other formulated products and articles (*e.g.*, adhesives, coatings, textiles, and electronics) via the potential leaching capacity of HBCD from these facilities (not through the disposal process of these formulated products and articles) or runoff. In lieu of having media-specific release information for this condition of use via leaching or surface runoff, background information (monitoring data) is used as a proxy to characterize the risk to aquatic organisms.

EPA first evaluated environmental exposures to aquatic organisms based on environmental monitoring data as well as modeled site-specific exposures or exposure scenarios. This non-scenario-specific approach estimates background exposure from a multitude of different sources. The totality of background exposure includes steady-state environmental exposures ongoing releases not associated with a particular COU, background/indirect exposures from minor use products (*e.g.*, textiles, electrical

and electronic products, adhesives, and coatings) (Section 1.2.8), and releases stemming from historical activities (Section 1.2.9) due to HBCD's persistence in the environment.

2.3.2.1.1 Surface Water Concentrations

EPA identified and extracted measured concentrations of HBCD in surface water from thirteen primary source studies. This dataset includes samples collected between 2006 and 2016 from rivers and lakes located in the United States (Great Lakes area), Antarctica, Canada, China, Denmark, England, Japan, Korea, Netherlands, Poland, and South Africa. A summary of occurrence of HBCD in surface water is presented in the *Risk Evaluation for Cyclic Aliphatic Bromide Cluster (HBCD), Supplemental Information on General Population, Environmental, and Consumer Exposure Assessment* ([U.S. EPA 2019d](#)).

Near facility

Following data aggregation and statistical analysis procedures, three studies were included in the surrogate country dataset for the near facility (point source) characterization. The central tendency and high-end surface water concentrations were 0.84 and 0.99 µg/L, respectively, with a maximum reported concentration of 3.1 µg/L. Overall, a tight range of values was reported. Concentrations at the higher end of the range were detected in Poland in 2014 near industrial facilities that recycle plastic materials ([Kowalski and Mazur 2014](#)) and in Japan in 2011 near dyeing and textile factories ([EC/HC 2011](#)). No U.S. near facility monitoring data was identified. A review of completed assessments shows similar results; with a maximum of 1.52 µg/L reported in the European Commission risk assessment ([EINECS 2008](#)) for a small tributary receiving surface water from a production facility estate in the UK.

Modeled site-specific and generic near facility estimates were also compiled from various international sources. In fresh or seawater, concentrations ranged from 4.8E-5 to 370 µg/L ([EINECS 2008](#); [EC/HC 2011](#); [NICNAS 2012](#); [ECHA 2017b](#)). The highest concentration represents a worst case generic scenario of an intermittent (single day) release from the industrial use of XPS ([ECHA 2017b](#)). [Ilyina and Hunziker 2010](#) predicted concentration in the North Sea using the Fate and Transport Ocean Model (FANTOM). Using estimated annual emissions for EU industrial sites, they estimated that HBCD concentrations in the surface water layer ranged from 10⁻⁶ to 0.1 µg/L. The modeling indicates that concentrations decline steeply with increasing distance from point sources and respond immediately to changes in emission, however, a product might be transported to remote environments depending on its half-life in the atmosphere.

Away from Facility

Following data aggregation and statistical analysis procedures, four studies were included in the surrogate country dataset for the away from facility (non-point source) characterization. The central tendency and high-end surface water concentrations were 4.1E-04 and 8.0E-04 µg/L, respectively, with a maximum reported concentration of 0.0067 µg/L. The highest concentration was reported in Japan from a study which collected samples from 19 sampling locations in the Yodo River basin consisting of forest, paddy field, and city areas, as well as highly urbanized and industrialized areas ([Ichihara et al. 2014](#)). This study reported flow rates and as well as estimated pollutant loads. It is noteworthy that the lowest flow river, the Yamato River, had the highest HBCD concentration. In the only U.S. study, ([Venier et al. 2014](#)) measured HBCD in surface water samples from the Great Lakes. Overall concentrations ranged from 2.0E-7 µg/L to 4.4E-6 µg/L, with an average of 1.2E-6 µg/L in detected samples (detection frequency of 14 out of 23 samples). Similar low concentrations were observed in nine lakes in the UK, with average concentrations ranging from 8.0E-5 µg/L to 2.7E-4 µg/L ([Harrad et al. 2009](#)).

Table 2-56. Summary of Central Tendency and High-End Estimated Surface Water Concentrations from Monitoring Data

Site Characterization	Number of Studies Identified	Number of Studies Included in Final Dataset	Estimated Concentrations (µg/L)	
			Central Tendency	High-End
Near Industrial Facility ^a (Point Source)	5	3 ^a	0.84	0.99
Away from Facility ^b (Non-Point Source)	9	4 ^b	4.1E-04	8.0E-04

^aNear industrial facility studies: ([Ichihara et al. 2014](#); [Kowalski and Mazur 2014](#); [Oh et al. 2014](#))

^bAway from facility studies: ([Law et al. 2006](#); [Harrad et al. 2009](#); [Ichihara et al. 2014](#); [Venier et al. 2014](#))

2.3.2.1.2 Sediment Concentrations

EPA identified and extracted measured concentrations of HBCD in surface water from 55 primary source studies. This dataset includes samples collected between 1974 and 2016 from freshwater and seawater in the United States, Australia, Canada, China, Czech Republic, England, Italy, Japan, Korea, Kuwait, Netherlands, Norway, Singapore, South Africa, South Korea, Spain, and Switzerland. A summary of occurrence of HBCD in sediment is presented in the *Risk Evaluation for Cyclic Aliphatic Bromide Cluster (HBCD), Supplemental Information on General Population, Environmental, and Consumer Exposure Assessment* ([U.S. EPA 2019d](#)).

Near Facility

Following data aggregation and statistical analysis procedures, six studies were included in the surrogate country dataset for the near facility (point source) characterization. The central tendency and high-end surface water concentrations were 3,443 and 5,073 µg/kg, respectively, with a maximum reported concentration of 85,000 µg/kg. The final surrogate country dataset included only one U.S. study, La Guardia ([La Guardia et al. 2010](#)), sediment samples were collected in 2009 in the vicinity of a municipal wastewater treatment plant (WWTP) in North Carolina that was likely receiving waste from a textile manufacturer. Total HBCD concentrations ranged from 3.1 to 42.9 µg/kg dw downstream of the outfall (0 to 44.6 km) and was not detected upstream from the outfall. Although not included in the final dataset due to incomplete statistical data reported, similar but lower concentrations ranging from non-detect to 3.7 µg/kg were reported in Marvin ([Marvin et al. 2006](#)), for suspended sediment samples collected in urban/industrial areas of the Detroit River in 2001. The higher concentrations (2.6 to 3.7 µg/kg) were reported in areas of contemporary industrial activity and the lower concentrations were associated with areas of historical industrial activity. The maximum concentration in the dataset is from Haukas ([Haukås et al. 2010b](#)), a Norwegian study that sampled sediment from a highly contaminated fjord with the likely source of HBCD from a local polystyrene production plant. The next highest reported concentration was 7,800 µg/kg from a Japanese study ([Oh et al. 2014](#)) that collected sediment from a river receiving effluents from textile industries. Two studies in Spain, ([Guerra et al. 2009](#)) and ([Guerra et al. 2010](#)), reported a trend with higher sediment concentrations located near point sources and decreasing sediment concentrations downstream from point sources, and non-detects upstream or further away from point sources.

Away from Facility

Following data aggregation and statistical analysis procedures, 14 studies were included in the surrogate country dataset for the away from facility (non-point source) characterization. The central tendency and high-end surface water concentrations were 6.2 and 19.8 µg/kg dw, respectively, with a maximum

reported concentration of 1,680 µg/kg dw. However, many studies in this dataset are based on statistical summaries for a range of land use patterns, thus the highest concentration were often from areas reported to be industrial in nature. HBCD concentrations from studies in which industrial activity was not reported tended to be less than 10 µg/kg dw. The two U.S. studies included in the surrogate country dataset included ([Yang et al. 2012](#)) which reported surface sediment concentrations ranging from 0.04 to 3.1 µg/kg dw collected from the five Great Lakes in 2007 and ([Klosterhaus et al. 2012](#)) which reported surface sediment concentrations ranging from 0.01 to 2 µg/kg dw collected from the San Francisco Bay estuary in 2007. As mentioned above, ([Marvin et al. 2006](#)) reported that suspended sediment in the Detroit River in areas of historical industry activity were less than 2.6 µg/kg.

The EC ([EINECS 2008](#)) assessment characterized sediment concentrations both near point sources and away from point sources in a meta-analysis of 16 studies encompassing locations in Belgium (Scheldt Basin), Switzerland, Spain, Ireland, Norway, Sweden, and United Kingdom. Reported concentrations ranged from 0.05 to 511 µg/kg for areas not impacted by point sources. Overall the data set is skewed with median HBCD concentration of 1.5 µg/kg, lower than the mean HBCD concentration of 31 µg/kg. The 90th percentile HBCD concentration was estimated as 100 µg/kg. When considering pollution by industrial activities, the maximum observed concentrations were more than 30,000 µg/kg, but were associated with production of HBCD and the textile industry.

Modeled site-specific and generic near facility estimates were also compiled from various international sources. In fresh or marine sediment, concentrations ranged from 1.0E-3 to 4.0E+6 µg/kg ([EINECS 2008](#); [EC/HC, 2011](#); [NICNAS 2012b](#); [ECHA 2017b](#)) The highest concentration represents a worst case generic scenario of an intermittent (single day) release from the industrial use of XPS ([ECHA 2017b](#)). Ilyina ([Ilyina and Hunziker 2010](#)) predicted concentration in the North Sea using the Fate and Transport Ocean Model (FANTOM). Using estimated annual emissions for EU industrial sites, they estimated HBCD concentrations in the surface water layer ranged from 10 E -4 to 10 µg/kg.

Table 2-57. Summary of Central Tendency and High-End Estimated Sediment Concentrations from Monitoring Data

Site Characterization	Number of Studies Identified	Number of Studies Included in Final Dataset	Estimated Concentrations (µg/kg)	
			Central Tendency	High-End
Near Industrial Facility (Point Source)	15	6 ^a	3,443	5,073
Away from Facility (Non-Point Source)	45	14 ^b	6.2	19.8

^a Near industrial facility studies: ([Sellstrom et al. 1998](#); [La Guardia et al. 2012](#); [Haukås et al. 2010b](#); [Oh et al. 2014](#); [Al-Odaini et al. 2015](#); [Stiborova et al. 2017](#))

^b Away from facility studies: ([Ramu et al. 2010](#); [Klosterhaus et al. 2012](#); [Yang et al. 2012](#); [Harrad et al. 2009](#); [Haukås et al. 2009](#); [Haukås et al. 2010b](#); [Kohler et al. 2008](#); [Minh et al. 2007](#); [Morris et al. 2004](#); [Remberger et al. 2004](#); [Jeong et al. 2014](#); [Luigi et al. 2015](#); [Lyons et al. 2015](#); [Al-Odaini et al. 2015](#); [Anim et al. 2017](#))

2.3.2.2 Scenario Specific Approach

This section describes the method and results from the scenario specific approach to estimating concentrations in the aquatic environment, when water releases are estimated to occur. E-FAST was used as a first-tier model to identify where modeled surface water column concentrations did or did not exceed aquatic hazard values. Since the E-FAST model incorporates defaults that encompass either a combination of upper percentile and mean exposure parametric values, or all upper percentile parametric

values, the resulting model predictions represent high-end exposures estimates. EPA acknowledges the conservative nature of this approach, and used the VVWM-PSC, to further describe environmental exposures as described later in this section. The VVWM-PSC model was then used to identify 1-day and 21-day average dissolved and suspended sediment water concentration as well as 28-day sediment concentrations. Appendix G contains the daily release amounts and environmental concentrations for each subscenario modeled.

2.3.2.2.1 E-FAST: Predicted Flowing Surface Water Concentrations (First Tier Modeling)

EPA's Exposure and Fate Assessment Screening Tool (E-FAST), Version 2.0, was specifically developed to support EPA assessments of potential environmental exposures. The E-FAST model contains default parameter values that allow for exposure estimations of a chemical in the surface water after a source emits the chemical into a water body by considering simple dilution. EPA uses Equation 2-5 to estimate surface water concentrations in E-FAST.

Equation 2-5

$$SWC = \frac{R \times CF1 \times \left(1 - \frac{T}{100}\right)}{SF \times CF2}$$

Where:

SWC = Surface water concentration in µg/L

R = Release kg/site/day

CF1 = Conversion factor (10⁹ µg/kg)

T = Percent removal, typically from wastewater treatment

SF = Flow of receiving river (million liters per day)

CF2 = Conversion factor (10⁶ L/day/MLD)

Inputs

Release (kg/site/day)

As discussed in Section 2.2, the daily release values (kg/site/day) were calculated using a production volume of 100,000 lbs/yr/site (or another lower facility specific estimate), emission factors (kg HBCD released/kg HBCD handled), and number of release days per year. Refer to Table 2-54 for a summary of the release values by COU and Appendix G for subscenario specific release values.

Removal from wastewater treatment (%)

Removal from wastewater treatment is the percentage of the chemical removed from wastewater during treatment before discharge to a body of water. As discussed in Section 2.1.2.4, removal from wastewater treatment for HBCD was estimated at 90%. EPA assumed that treatment occurs for "on-site WWT" and "POTW" release types, and that 90% removal was achieved. EPA assumed that direct releases to water did not receive wastewater treatment and no wastewater treatment removal was applied. This is a conservative assumption that results in the total amount of HBCD released to wastewater treatment at a direct discharging site being released to surface water. This assumption reflects the uncertainty of the type of wastewater treatment that may be in use at a direct discharging facility and the HBCD removal efficiency in that treatment.

Flow of receiving river (million liters per day)

E-FAST requires the selection of a receiving stream flow from the E-FAST 2014 database. For site-specific assessments, the stream flow is selected by searching for a facility's National Pollutant Discharge Elimination System (NPDES) permit number, name, or the known discharging waterbody reach code. As no specific facilities were identified for the HBCD assessment for water releases, stream flows were selected using the "SIC Code Option" within E-FAST. This option uses the 10th and 50th percentile stream flows of all facilities in a given industry sector, as defined by the Standard Industrial Classification (SIC) codes of the industry sector. For all "surface water" and "on-site WWT" release types, the sector based stream flows used were "POTW All" for subscenarios in COU 8 (installation of insulation into building scenario) and "Plastic Resins" for subscenarios in all other COUs. For the "POTW" release type, the SIC based stream flow of "Industrial POTWs" was used. These SIC Code stream flows were selected because they were thought to best represent the industrial activity associated with the conditions of use and release type.

The flow of rivers is highly variable and is dependent on many factors such as weather patterns and effluent released from different facilities. The volume of a river varies over time with different flows expected seasonally and from year to year. The 10th and 50th percentile 7Q10 flows, which represent the lowest expected weekly flow over a ten-year period, were selected for use in the ecological risk assessment. In general, the 10th percentile flow values are approximately a factor of 10 lower than 50th percentile flows. The flows for the selected industry sector/SIC Code are shown in Table 2-58. Although not used in the ecological assessment, harmonic means are also shown since they were used to calculate surface water concentrations for the scenario specific fish ingestion scenario in the highly exposed human exposure assessment. Harmonic mean flow values represent long-term average flow conditions.

Table 2-58. Receiving Stream Flow Values

Sector Within EFAST	7Q10 Flow MLD 50 th percentile	7Q10 Flow MLD 10 th percentile	Harmonic Mean Flow MLD 50 th percentile	Harmonic Mean Flow MLD 10 th percentile
SIC Code- Plastic Resins	4.0E+02	8.0E+00	1.3E+03	4.5E+01
SIC Code- Industrial POTW	7.8E+01	7.8E+00	2.9E+02	4.0E+01
SIC Code- All POTW	2.7E+01	1.1E+00	1.3E+02	1.1E+01

Outputs

Overall, surface water concentrations ranged from 8.30E-05 to 1.10E+02 µg/L using the 50th percentile 7Q10 flows and 4.20E-03 to 5.30E+03 using the 10th percentile 7Q10 flows. Refer to Table 2-59 for a summary of modeled surface water estimates by condition of use, and Appendix E.7 for results by sub-scenario.

Table 2-59. Estimated HBCD Surface Water (µg/L) Concentrations Using E-FAST

Water Scenarios	7Q10 SWC 50 th percentile	7Q10 SWC 10 th percentile
W1.1 to W1.8	3.7E-02 - 1.0E+01	1.9E+00 - 1.0E+02
W2.1 to W2.12	6.1E-03 - 8.4E-01	3.0E-01 - 4.2E+01
W3.1 to W3.12	1.0E-02 - 3.0E+00	4.0E-01 - 1.5E+02
W4.1 to W4.6	9.7E-03 - 1.2E+00	4.9E-01 - 5.8E+01
W5.1 to W5.12	8.8E-01 - 1.1E+02	4.4E+01 - 5.3E+03

Water Scenarios	7Q10 SWC 50th percentile	7Q10 SWC 10th percentile
W6.1 to W6.12	1.9E-03 - 1.6E+00	9.5E-02 - 8.0E+01
W8.1 to W8.4	3.2E-04 - 3.7E-01	8.0E-03 - 9.4E+00
W9.1 to W9.4	2.8E-03 - 2.5E+01	7.2E-02 - 6.4E+02
W10.1 to W10.12	1.2E-03 - 2.0E+00	5.9E-02 - 9.9E+01
W12.1 to W12.8	8.3E-05 - 6.4E-02	4.2E-03 - 6.4E-01

Bold = concentration above water solubility of 66 µg/L

Advantages to the E-FAST model are that it requires minimal input parameters and it has undergone extensive peer review by experts outside of EPA. The limitations associated with use of the E-FAST model relate to the assumptions made regarding use of sector-based flow information as a surrogate for site-specific flow information, as well as lack of partitioning (between dissolved and suspended sediment within the water column or between the water column and the benthic environment) and degradation parameters that were employed in the PSC model. Additionally, low-flow stream inputs combined with high-release estimates may yield overly conservative surface water concentrations greater than the water solubility of HBCD.

Site-specific parameters influence how partitioning occurs over time. For example, the concentration of suspended sediments, water depth, and weather patterns all influence how a chemical may partition between compartments. Physical-chemical properties of the chemical itself also influence partitioning and half-lives into environmental media. HBCD has a K_{oc} of 100,000, indicating a high potential to sorb to suspended particles in the water column and settled sediment in the benthic environment. Canada ([EC/HC, 2011](#)) considered these parameters when estimating surface water and sediment concentrations of HBCD in rivers receiving HBCD from two types of point sources (raw material handling and compounding). Surface water and sediment concentrations were estimated at 100 m from the facility and 5,000 m from the facility using a fugacity-based model with 10 downstream boxes each with water and sediment compartments. The model is based on the principles described by [Cahill et al. \(2003\)](#), and more generally [Mackay \(1991\)](#). The Canadian modeled estimates ranged from 0.04 to 15 µg/L in surface water at 100 m from the facility, which is within the range of the E-FAST estimated values. At 5 km from the facility, the modeled concentrations ranged from 0.03 to 10 µg/L. In sediment, the Canadian model predicted concentrations from 230 to 108,200 µg/kg. The Canadian estimates were modeled using a quantity of 10,000 kg/year with 60 days of release and 100,000 kg/year with 200 days of release, combined with worst-case emission factors of 0.055% (raw material handling) and 0.6% (compounding), and treatment removal rates of 0, 57, and 90%. Stream discharge was set to 0.85 m³/s (73 MLD) to represent the 25th percentile of observed rates in Southern Ontario. This resulted in 6 subscenarios per point source. It is noteworthy that this modeling was conducted when releases to surface water from uses of HBCD were likely higher than they are today.

2.3.2.2.2 VVWM-PSC: Predicted Flowing Surface Water Concentrations (Second Tier Modeling) and Sediment Concentrations

As a second tier approach, EPA used the Variable Volume Waterbody Model (VVWM) - Point Source Calculator (PSC) ([U.S. EPA, 2019q](#)) to model dissolved water and settled sediment concentrations separately, using the same surface water release estimates used in E-FAST (refer to Table 2-54 for the daily release estimates). The PSC is a tool designed to estimate time-varying surface water concentrations of a chemical directly applied to a water body, including but not limited to river segments. Loading into the river can be varied daily, set up to be discrete one-time events, or repetitive

events over most or all of the year. The PSC is a graphical user interface which gathers the user's inputs and runs USEPA's VVWM. Required inputs are the same as those for the VVWM, but the PSC graphical interface facilitates user interaction for the direct-application and allows model inputs to be defined by the user. Time-varying surface water concentrations can be averaged over variable time periods for comparison to concentrations of concern. For example, 21-day average surface water concentrations and 28-day average sediment concentrations were used for EPA's modeling assessment.

Inputs

More information on the equations used to estimate surface water and sediment concentrations are available in the PSC user guide ([U.S. EPA, 2019q](#)). In short, daily releases and daily flow values are used along with other model inputs to solve mass-balance equations for the water column and for the benthic region.

Surface water flow can be set up to be constant flow or use time-varying flows. Since site-specific information is not available for the HBCD assessment, constant flows matching the SIC-based flow values used in E-FAST were selected (refer to Table 2-58). Suspended sediment values are highly variable and are influenced by stream flow, land cover, and river conditions. A K_{oc} value of 100,000 was chosen based on measured data. A weather file is also needed to run VVWM-PSC. This incorporates variable flow volume through precipitation events. However, variation through precipitation alters stream flow much less than variations in stream flow from other factors. Use of a constant flow which varied across scenarios was chosen. Table 2-60 displays the inputs used to run the VVWM-PSC for HBCD.

Table 2-60. Inputs for Modeling HBCD Sediment Concentration using VVWM-PSC

Input	Type of Input	Value	Units, Comments	Reference
Sorption Coefficient (K_{oc})	Chemical	100,000	ml/g	(ECHA 2017b)
Water Column, Hydrolysis, and Photolysis Half-lives	Chemical	365	Days	
Benthic Half-Live	Chemical	11 to 128	Days	(Davis et al. 2005) (Davis et al. 2006)
Molecular weight	Chemical	641.7	g/mol	
Henry's Law Constant	Chemical	7.4E-6	atm-m ³ /mole	(U.S. EPA 2012b)
Heat of Henry	Chemical	41570	J/mol	(U.S. EPA 2019q)
Loading schedule	Chemical	Varies can add separate table and/or add combinations here.	Offset, number of days on and off	
River width	Environment	8	Meters	(EC/HC 2011)
River depth	Environment	2	Meters	
River length	Environment	100	Meters	
Flow rate	Environment	Varies	See Table 2-37	(U.S. EPA 2014c)
DFAC	Environment	1.19	Photolysis parameter: Represents the ratio of	(U.S. EPA 2019q)

Input	Type of Input	Value	Units, Comments	Reference
			vertical path lengths to depth	
Water Column Suspended Sediment	Environment	50	mg/L	(Dodds and Oakes 2004)
Chlorophyll	Environment	0.005	mg/L	(U.S. EPA 2019q)
Water Column Fraction Organic Content	Environment	0.04	Fraction	
Water Column Dissolved Oxygen Content	Environment	5.0	mg/L	
Water Column Biomass	Environment	0.4	mg/L	
Benthic Depth	Environment	0.05	M	
Benthic Porosity	Environment	0.5		
Bulk Density	Environment	1.35	g/cm ³	
Benthic Fraction Organic Content	Environment	0.04		
Benthic Dissolved Oxygen Content	Environment	5.0	mg/L	
Benthic Biomass	Environment	0.006	g/m ²	
Mass Transfer Coefficient	Environment	1e-8	m/s	

Outputs

A summary of the estimated surface water and sediment concentrations from VVWM-PSC by condition of use is provided in Table 2-61 based on 7Q10 50th percentiles and in Table 2-62 based on 7Q10 10th percentiles. Sediment concentrations were calculated for both a 11 and 128 day benthic half-life to account for the large range of values. The 1-day average overall surface water column concentrations are similar to estimated surface water concentrations from E-FAST because the same flow values were used. Further, the PSC was only run for scenarios where the estimated surface water concentration from E-FAST exceeded an acute or chronic aquatic hazard value (discussed in Section 3.1). See Section 2.3.6 regarding the qualitative sensitivity analysis associated with these results.

Table 2-61. Estimated HBCD Surface Water Concentrations (µg/L) and Sediment Concentrations (µg/kg) Using VVWM-PSC with 50th Percentile 7Q10 Flows

Water Scenarios	Water Column 1 Day average	Water Column Dissolved 1 Day µg/L	Water Column Suspended 1 Day µg/L	Water Column µg/L 21 day average	Water Column 21 day Dissolved µg/L	Water Column 21 day Suspended µg/L	Sediment µg/kg 28 day average (128) ^a	Sediment µg/kg 28 day average (11) ^a
W1.1 to W1.8	3.7E-02 - 9.7E+00	2.8E-02 - 7.3E+00	5.6E-03 - 1.5E+00	3.0E-02 - 9.4E-01	2.3E-02 - 7.1E-01	4.6E-03 - 1.4E-01	7.7E+01 - 2.0E+03	3.4E+01 - 8.7E+02
W2.1 to W2.12	3.7E-02 - 8.3E-01	2.8E-02 - 6.3E-01	5.6E-03 - 1.3E-01	1.8E-03 - 4.0E-02	1.3E-03 - 3.0E-02	2.7E-04 - 6.0E-03	2.8E+00 - 6.3E+01	1.3E+00 - 3.0E+01
W3.1 to W3.12	8.0E-03 - 2.9E+00	6.0E-03 - 2.2E+00	1.2E-03 - 4.4E-01	3.8E-04 - 1.4E-01	2.9E-04 - 1.1E-01	5.8E-05 - 2.1E-02	8.9E-01 - 1.2E+02	4.0E-01 - 8.9E+01
W4.1 to W4.6	9.6E-03 - 1.1E+00	7.3E-03 - 8.6E-01	1.5E-03 - 1.7E-01	4.6E-04 - 5.4E-02	3.5E-04 - 4.1E-02	6.9E-05 - 8.2E-03	8.2E-01 - 4.6E+01	3.7E-01 - 3.5E+01

Water Scenarios	Water Column 1 Day average	Water Column Dissolved 1 Day $\mu\text{g/L}$	Water Column Suspended 1 Day $\mu\text{g/L}$	Water Column $\mu\text{g/L}$ 21 day average	Water Column 21 day Dissolved $\mu\text{g/L}$	Water Column 21 day Suspended $\mu\text{g/L}$	Sediment $\mu\text{g/kg}$ 28 day average (128) ^a	Sediment $\mu\text{g/kg}$ 28 day average (11) ^a
W5.1 to W5.12	8.8E-01 - 1.1E+02	6.6E-01 - 7.9E+01	1.3E-01 - 1.6E+01	2.9E-01 - 5.0E+00	2.2E-01 - 3.8E+00	4.5E-02 - 7.6E-01	7.6E+02 - 1.2E+04	3.3E+02 - 5.5E+03
W6.1 to W6.12	8.4E-03 - 1.6E+00	6.4E-03 - 1.2E+00	1.3E-03 - 2.4E-01	1.7E-03 - 7.5E-02	1.3E-03 - 5.7E-02	2.6E-04 - 1.1E-02	4.1E+00 - 1.8E+02	1.9E+00 - 8.3E+01
W8.1 to W8.4	2.9E-03 - 3.4E+00	2.2E-0 -3 2.6E+00	4.4E-04 - 5.1E-01	1.4E-04 - 4.9E-01	1.1E-04 - 3.7E-01	2.1E-05 - 7.4E-02	1.2E-01 - 1.6E+02	8.9E-02 - 1.1E+02
W9.1 to W9.4	2.3E+00 - 2.3E+01	1.7E+00 - 1.7E+01	3.5E-01 - 3.5E+00	1.1E-01 - 1.1E+00	8.5E-02 - 8.5E-01	1.7E-02 - 1.7E-01	9.4E+01 - 9.4E+02	7.0E+01 - 7.0E+02
W10.1 to W10.12	1.2E-02 - 2.0E+00	8.9E-03 - 1.5E+00	1.8E-03 - 3.0E-01	3.9E-03 - 9.3E-02	3.0E-03 - 7.1E-02	6.0E-04 - 1.4E-02	6.6E+00 - 9.6E+01	4.5E+00 - 6.0E+01
W12.1 to W12.8	6.2E-03 - 6.2E-02	4.7E-03 - 4.7E-02	9.3E-04 - 9.4E-03	2.9E-04 - 3.0E-03	2.2E-04 - 2.3E-03	4.5E-05 - 4.5E-04	2.9E-01 - 2.9E+00	1.9E-01 - 1.9E+00

^a sediment benthic half-life (days)
Bold = concentration above the water solubility of 66 $\mu\text{g/L}$

Table 2-62. Estimated HBCD Surface Water Concentrations ($\mu\text{g/L}$) and Sediment Concentrations ($\mu\text{g/kg}$) Using VVWM-PSC with 10th Percentile 7Q10 Flows

Water Scenarios	Water Column 1 Day average	Water Column Dissolved 1 Day $\mu\text{g/L}$	Water Column Suspended 1 Day $\mu\text{g/L}$	Water Column $\mu\text{g/L}$ 21 day average	Water Column 21 day Dissolved $\mu\text{g/L}$	Water Column 21 day Suspended $\mu\text{g/L}$	Sediment $\mu\text{g/kg}$ 28 day average (128) ^a	Sediment $\mu\text{g/kg}$ 28 day average (11) ^a
W1.1 to W1.8	1.7E+00 - 7.6E+01	1.3E+00 - 5.7E+01	2.6E-01 - 1.1E+01	1.5E+00 - 8.9E+00	1.1E+00 - 6.7E+00	2.2E-01 - 1.3E+00	3.6E+03 - 1.9E+04	1.4E+03 - 7.2E+03
W2.1 to W2.12	1.4E+00 - 3.1E+01	1.1E+00 - 2.4E+01	2.1E-01 - 4.7E+00	7.9E-02 - 1.8E+00	5.9E-02 - 1.3E+00	1.2E-02 - 2.7E-01	1.3E+02 - 2.9E+03	5.4E+01 - 1.2E+03
W3.1 to W3.12	3.0E-01 - 1.1E+02	2.3E-01 - 8.3E+01	4.6E-02 - 1.7E+01	1.8E-02 - 5.7E+00	1.4E-02 - 4.3E+00	2.7E-03 - 8.6E-01	4.1E+01 - 4.7E+03	1.6E+01 - 3.5E+03
W4.1 to W4.6	3.6E-01 - 4.3E+01	2.7E-01 - 3.2E+01	5.5E-02 - 6.5E+00	2.1E-02 - 2.2E+00	1.6E-02 - 1.7E+00	3.1E-03 - 3.3E-01	3.9E+01 - 1.8E+03	1.5E+01 - 1.4E+03
W5.1 to W5.12	3.6E+01 - 4.0E+03	2.7E+01 - 3.0E+03	5.4E+00 - 6.0E+02	1.4E+01 - 2.4E+02	1.1E+01 - 1.8E+02	2.1E+00 - 3.6E+01	3.6E+04 - 5.7E+05	1.4E+04 - 2.3E+05
W6.1 to W6.12	3.9E-01 - 6.0E+01	2.9E-01 - 4.5E+01	5.9E-02 - 9.0E+00	7.9E-02 - 3.5E+00	6.0E-02 - 2.7E+00	1.2E-02 - 5.3E-01	1.9E+02 - 8.5E+03	7.6E+01 - 3.4E+03
W8.1 to W8.4	2.0E-02 - 2.4E+01	1.5E-02 - 1.8E+01	3.0E-03 - 3.6E+00	1.3E-03 - 1.7E+00	9.8E-04 - 1.3E+00	2.0E-04 - 2.6E-01	1.1E+00 - 2.0E+03	7.6E-01 - 9.0E+02
W9.1 to W9.4	1.6E+01 - 1.6E+02	1.2E+01 - 1.2E+02	2.4E+00 - 2.4E+01	1.0E+00 - 1.0E+01	7.7E-01 - 7.7E+00	1.5E-01 - 1.5E+00	8.4E+02 - 8.4E+03	6.0E+02 - 6.0E+03
W10.1 to W10.12	4.8E-01 - 7.3E+01	3.6E-01 - 5.5E+01	7.3E-02 - 1.1E+01	1.9E-01 - 3.8E+00	1.4E-01 - 2.8E+00	2.8E-02 - 5.7E-01	2.6E+02 - 3.1E+03	1.8E+02 - 2.3E+03
W12.1 to W12.8	2.3E-01 - 4.7E-01	1.7E-01 - 3.6E-01	3.5E-02 - 7.2E-02	1.2E-02 - 2.5E-02	9.2E-03 - 1.9E-02	1.8E-03 - 3.8E-03	1.3E+01 - 2.6E+01	7.4E+00 - 1.5E+01

^a sediment benthic half-life (days)
Bold = concentration above the water solubility of 66 $\mu\text{g/L}$

2.3.2.2.3 IIOAC: Predicted Pond Water and Sediment Concentrations

With an estimated half-life in air of more than two days, and having been detected in Arctic environmental media, there is strong evidence of HBCD's potential for long-range transport ([UNEP 2010b](#)). EPA calculated the concentration of HBCD in pond water and sediment resulting from air deposition using a two-step process.

In the first step, near-facility HBCD annual deposition rates were modeled using EPA's Integrated Indoor-Outdoor Air Calculator (IIOAC) for 11 condition of use-exposure scenarios with air releases. Under each scenario, multiple model runs were performed to include different source types and high-end and central tendency release estimates, as summarized in Table 2-55. For scenarios with site-specific information, this information was used in the IIOAC model runs to determine the meteorological station and population setting. When site-specific information was not known, representative central tendency and high-end meteorological stations were used, along with other default parameters in Appendix G. Table_Apx F-4 in the Environmental Exposure appendix presents the modeled range of total annual particle deposition for each exposure scenario by source type (fugitive, stack, incineration) and by receptor (fenceline, community). Fenceline estimates were defined as 100-meter from the source while community-averaged estimates were within 100 to 1,000-meter from the facility. From the table, the highest total annual particle deposition amongst all exposure scenarios was:

- 2.28E-05 g/m² at the fenceline (100 m from the source); and
- 1.75E-06 g/m² at "community" receptors beyond the fenceline (100 to 1,000 m from the source).

Background deposition rates of HBCD were also reported in a recent study near the Great Lakes and ranged from non-detectable levels up to 82 ng/m²/d, with an average of 2.3 ng/m²/d. These values corresponded to wet deposition of HBCD as detected with automated wet-deposition samplers located at sites ranging from remote to peri-urban ([Robson et al. 2013](#)). Observed HBCD deposition values varied by location (perhaps due in part to meteorological conditions) and, to a lesser extent, by time, though sampling time was limited to four years at some sites. For comparison to the IIOAC-modeled values, EPA assumed that the observed per-day fluxes from ([Robson et al. 2013](#)) were held constant for a year, resulting in:

- 2.99E-05 g/m²/y for maximum deposition; and
- 8.40E-07 g/m²/y for average deposition

Using the deposition rates estimated by IIOAC and the background deposition rates reported by ([Robson et al. 2013](#)), the total annual deposition and resulting surface water and sediment concentrations were calculated for a generic farm pond scenario. The scenario is based off of EPA's Office of Pesticides (OPP) standard farm scenario as described in various models such as the EXAMS model and GENEEC2. Equation 2-6 was used to calculate the total annual deposition to the water body (µg) and the HBCD surface water and sediment concentrations were calculated using Equation 2-7 and Equation 2-8, respectively.

Equation 2-6

$$AnnDep = TotDep \times Ar \times CF$$

Where

$$\begin{aligned} AnnDep &= \text{Total annual deposition to water body catchment } (\mu\text{g}) \\ TotDep &= \text{Annual deposition flux to water body catchment } (\text{g}/\text{m}^2) \end{aligned}$$

<i>Ar</i>	=	Area of water body catchment (m ²)
<i>CF</i>	=	Conversion of grams to micrograms

Equation 2-7

$$PondWaterConc = \frac{AnnDep}{Ar \times Pond\ Depth}$$

Where

<i>PondWaterConc</i>	=	Annual-average concentration in water body (µg/kg)
<i>AnnDep</i>	=	Total annual deposition to water body (µg)
<i>Ar</i>	=	Area of water body (m ²); default = 10,000 m ² from EPA OPP standard farm pond scenario
<i>Pond Depth</i>	=	Depth of pond; default = 2 m from EPA OPP standard farm pond scenario
<i>CF</i>	=	Conversion of cubic meters to liters

Equation 2-8

$$PondSedimentConc = \frac{AnnDep}{Ar \times Mix \times Dens}$$

Where

<i>PondWaterConc</i>	=	Annual-average concentration in water body (µg/kg)
<i>AnnDep</i>	=	Total annual deposition to water body (µg)
<i>Ar</i>	=	Area of water body (m ²); default = 10,000 m ² from EPA OPP standard farm pond scenario
<i>Pond Depth</i>	=	Depth of pond; default = 2 m from EPA OPP standard farm pond Scenario
<i>Mix</i>	=	Mixing depth (m); default = 0.1 m
<i>Dens</i>	=	Density of sediment; default = 1,300 kg/m ³ from the European Commission Technical Guidance Document (ECB 2003)

The highest estimated surface water and sediment concentrations amongst all exposure scenarios is provided in Table 2-63. Summary of Annualized Deposition and Estimated Pond Surface Water and Sediment Concentration from Air Deposition for fence-line receptors (100 m from the source) and “community” receptors beyond the fence-line (100 to 1,000 m from the source). For comparison, the concentrations calculated from the average and high-end deposition from ([Robson et al. 2013](#)) is also provided. The concentrations were in the same order of magnitude as the surface water and sediment concentrations estimated using VVWM-PSC.

Table 2-63. Summary of Annualized Deposition and Estimated Pond Surface Water and Sediment Concentration from Air Deposition

Scenario Name	Annualized Deposition (g/m ² /y)	Estimated Concentration in Pond Water (µg/L)	Estimated Concentration in Pond Sediment (µg/kg)
Highly Exposed Population - High-end IIOAC-modeled fence line	2.3E-05	1.1E-02	1.8E-01
Highly Exposed Population - High-end IIOAC-modeled community	1.8E-06	8.7E-04	1.4E-02
Background - High-end from (Robson et al. 2013)	3.0E-05	1.5E-02	2.3E-01
Background - Average from (Robson et al. 2013)	8.4E-07	4.2E-04	6.5E-03

2.3.3 Terrestrial Environment – Soil

2.3.3.1 Non-Scenario Specific Approach – Air Deposition and Biosolid Application

This non-scenario specific approach uses measured media-specific monitoring data to characterize background exposure to HBCD where releases attributed to historical and current conditions of use may be encompassed. As described below in Section 2.3.3.2, all exposure scenarios with air releases have predicted soil HBCD concentrations, except for the recycling of electronics waste containing HIPS and land disposal of other formulated products and articles (*e.g.*, adhesives, coatings, textiles, and electronics). In regards to the recycling of electronics waste containing HIPS, a semi-quantitative screening approach was used to compare industrial releases associated with this exposure scenario to those of other exposure scenarios with air releases; the release days and amount of HBCD released were factors considered to determine whether this exposure scenario will likely have soil concentrations of HBCD that may exceed the chronic hazard threshold for earthworms. In regards to the land disposal of textiles, electrical and electronic products, adhesives and coatings, in lieu of having media-specific release information for this condition of use via leaching or surface runoff, background information (monitoring data) is used as a proxy to characterize the risk to aquatic organisms.

EPA first evaluated environmental exposures to terrestrial organisms from soil based on environmental monitoring data as opposed to modeled site-specific exposures or exposure scenarios. This non-scenario-specific approach estimates background exposure from a multitude of different sources. The totality of background exposure includes steady-state environmental exposures to ongoing releases not associated with a particular COU, background/indirect exposures from minor use products (*e.g.*, textiles, electrical and electronic products, adhesives, and coatings) (Section 1.2.8), and releases stemming from historical activities (Section 1.2.9) due to HBCD's persistence in the environment. For the non-scenario specific approach, EPA estimated soil concentrations from two sources: air deposition and biosolids application.

Air deposition

For air deposition, EPA identified and extracted measured concentrations of HBCD in soil from 21 primary source studies. This dataset includes samples collected between 1999 and 2015 in Belgium, Cambodia, China, Indonesia, Sweden, and Vietnam. No U.S. studies were identified. A summary of

occurrence of HBCD in soil is presented in the *Risk Evaluation for Cyclic Aliphatic Bromide Cluster (HBCD), Supplemental Information on General Population, Environmental, and Consumer Exposure Assessment* (U.S. EPA 2019d).

Following data aggregation and statistical analysis procedures, the surrogate country datasets included only one study for near facility (point source) characterization and two studies for background (non-point source) characterization. The near facility study was (Remberger et al. 2004), in which three soil samples were collected between 300 and 700 m from a flame retardant XPS plastic production facility in Sweden, with concentrations ranging from 140 to 1,300 µg/kg dw (calculated central and high-end values of 1,016 and 1,254 µg/kg dw). The two background studies were Covaci et al. 2009 and Newton et al. 2015. In Covaci et al. 2009, soil samples were collected in the perimeter of a home chicken run in Belgium. In Newton et al. 2015, soil samples were collected in undisturbed rural and urban areas in Stockholm, Sweden. The estimated central and high-end values from these studies are 1.4 and 3.0 µg/kg dw, respectively.

Most soil studies were collected in China. (Wu et al. 2016b) reported soil concentrations ranging from 0.3 to 249 µg/kg dw, with a median of 5.14 µg/kg dw, from samples collected in 2012 in areas that represented a wide variety of land-use types. The soil concentration was influenced by the sample depth as well as proximity to facilities, with higher concentrations reported near industrial areas. In another Chinese study, (Tang et al. 2014) collected 90 samples across in residential and agricultural areas across the Ningbo Region of China. The overall range of soil concentrations reported was ND (<0.068 µg/kg) in farmland areas to 103 µg/kg in industrial areas; land-use highly influenced the overall magnitude of reported soil concentrations.

Table 2-64. Summary of Central Tendency and High-End Estimated Soil Concentrations from Monitoring Data

Site Characterization	Number of Studies Identified	Number of Studies Included in Final Dataset	Estimated Concentrations (µg/kg)	
			Central Tendency	High-End
Near Industrial Facility (Point Source)	9	1 ^a	1,016	1,254
Away from Facility (Non-Point Source)	17	2 ^b	1.4	3.0

^a Near industrial facility studies: (Remberger et al. 2004)

^b Away from facility studies: (Covaci et al. 2009; Newton et al. 2015)

Biosolid application

EPA assumes that HBCD that may be deposited to soil through application of biosolids to agricultural lands. EPA identified and extracted sludge concentrations from 17 studies. Overall, samples were collected between 2000 and 2016 from Australia, Canada, China, Czech Republic, Indonesia, Netherlands, South Korea, Spain, Sweden, Switzerland, and the United States. A summary of occurrence of HBCD in biosolids is presented in the *Risk Evaluation for Cyclic Aliphatic Bromide Cluster (HBCD), Supplemental Information on General Population, Environmental, and Consumer Exposure Assessment* (U.S. EPA 2019d).

Two U.S. studies were identified. Venkatesan (Venkatesan and Halden 2014) reported a concentration of 19.8 µg/kg dw in a single composite sewage sludge sample representing 94 WWTP in 32 U.S. states.

The samples were collected for EPA's 2001 national sewage sludge survey (NSSS). La Guardia ([La Guardia et al. 2010](#)) collected secondary sewage sludge samples from a drying lagoon in 2002, 2005, 2007, and 2008 from one publicly owned WWTP in the Mid-Atlantic U.S. The facility treated domestic and industrial waste, including discharges from an automobile interior manufacturer, although the manufacturer relocated from the area in mid-2006. Only one sample, consisting of several grab samples combined, was analyzed each year. Total HBCD concentrations corrected for TOC content (7 to 28%) were 324, 400,000, 23125, and 3,171 $\mu\text{g}/\text{kg dw}$, with a geometric mean concentration of 100,000 $\mu\text{g}/\text{kg dw}$ (10 mg/kg). These concentrations are several orders of magnitude higher than the levels reported in Venkatesan ([Venkatesan and Halden 2014](#)), presumably due to the industrial nature of the waste received at the WWTP.

To assess soil concentrations resulting from biosolid applications, EPA relied upon modeling work conducted in Canada ([EC/HC 2011](#)), which used Equation 60 of the European Commission Technical Guidance Document (TGD) ([ECB 2003](#)). The equation in the TGD is as follows:

Equation 2-9

$$PEC_{soil} = \frac{C_{sludge} \times AR_{sludge}}{D_{soil} \times BD_{soil}}$$

where:

PEC_{soil} = Predicted environmental concentration (PEC) for soil (mg/kg)

C_{sludge} = concentration in sludge (mg/kg)

AR_{sludge} = application rate to sludge amended soils ($\text{kg}/\text{m}^2/\text{yr}$); default = 0.5 from Table A-11 of TGD

D_{soil} = depth of soil tillage (m); default = 0.2 m in agricultural soil and 0.1 m in pastureland from Table A-11 of TGD

BD_{soil} = bulk density of soil (kg/m^3); default = 1,700 kg/m^3 from Section 2.3.4 of TGD

The concentration in sludge was assumed to 10 $\text{mg}/\text{kg dw}$ based on ([La Guardia et al. 2012](#)), which was the value also used in the Canadian assessment ([EC/HC 2011](#)). Using these assumptions, the estimated soil concentrations after the first year of application were 15 $\mu\text{g}/\text{kg}$ in tilled agricultural soil and 30 $\mu\text{g}/\text{kg}$ in pastureland.

A limitation of Equation 2-9 is that it assumes no losses from transformation, degradation, volatilization, erosion or leaching to lower soil layers. Additionally, it is assumed there is no input of HBCD from atmospheric deposition and there are no background HBCD accumulations in the soil.

2.3.3.2 Scenario Specific Approach – Air Deposition

Soil concentrations from air deposition were also estimated for the condition of use scenarios with air releases. The air deposition modeling was conducted using IIOAC. A description of the modeling and the deposition results is provided above in Section 2.3.2.2.3. For comparison, EPA also reviewed deposition from ([Robson et al. 2013](#)), assuming that the observed per-day fluxes from were held constant for a year. Using the deposition rates, the HBCD concentration in soil was calculated with the following equations:

Equation 2-10

$$AnnDep = TotDep \times Ar \times CF$$

Where

<i>AnnDep</i>	=	Total annual deposition to soil (µg)
<i>TotDep</i>	=	Annual deposition flux to soil (g/m ²)
<i>Ar</i>	=	Area of soil (m ²)
<i>CF</i>	=	Conversion of grams to micrograms

Equation 2-11

$$\text{SoilConc} = \frac{\text{AnnDep}}{\text{Ar} \times \text{Mix} \times \text{Dens}}$$

Where

<i>SoilConc</i>	=	Annual-average concentration in soil (µg/kg)
<i>AnnDep</i>	=	Total annual deposition to soil (µg)
<i>Mix</i>	=	Mixing depth (m); default = 0.1 m from the European Commission Technical Guidance Document (ECB 2003)
<i>Ar</i>	=	Area of soil (m ²)
<i>Dens</i>	=	Density of soil; default = 1,700 kg/m ³ from the European Commission Technical Guidance Document (ECB 2003)

The above equations assume instantaneous mixing with no degradation or other means of chemical reduction in soil over time and that HBCD loading in soil is only from direct air-to-surface deposition (*i.e.*, no runoff).

Table_Apx F-5 in the Environmental Exposure appendix presents the range of calculated soil concentrations corresponding to the emission scenarios considered. From the table, the highest estimated soil concentration amongst all exposure scenarios was:

- 1.34E-01 µg/kg at the fenceline (100 m from the source); and
- 1.03E-02 µg/kg at “community” receptors beyond the fenceline (100 to 1,000 m from the source).

These soil concentrations can be compared to results obtained when background deposition rates from ([Robson et al. 2013](#)) are used:

- 1.76E-01 µg/kg based on the maximum background deposition from ([Robson et al. 2013](#)); and
- 4.94E-03 µg/kg based on the average background deposition from ([Robson et al. 2013](#)).

Among the deposition scenarios modeled with IIOAC, the community receptors are likely more appropriate for typical exposure-assessment purposes, which consider locations where the public would have regular access (the IIOAC community receptors are within 1 kilometer from the facility). The spatial averages provided by the community receptors are also more appropriate to use for deposition to areas of soil since they cover a larger surface area. The highest IIOAC-modeled deposition at the community receptors is nearly a factor of 5 above the average “background” value observed in the monitoring study of ([Robson et al. 2013](#)). Differences in HBCD concentrations in soil are proportional to differences in deposition. It is logical that the high-end modeled values of deposition and soil concentrations near a facility, averaged over a year, are substantially higher than long-term-averaged values resulting from general transport. Remaining IIOAC deposition rates are comparable with the

reported by ([Robson et al. 2013](#)). Table 2-65 summarizes the total annual deposition rates and corresponding soil concentrations.

Table 2-65. Summary of Annualized Deposition and Estimated Soil Concentration from Air Deposition

Scenario Name	Annualized Deposition (g/m ² /y)	Estimated Concentration in Soil (µg/kg)
Highly Exposed Population - High-end IIOAC-modeled fenceline	2.3E-05	1.3E-01
Highly Exposed Population - High-end IIOAC-modeled community	1.8E-06	1.0E-02
Background - High-end from (Robson et al. 2013)	3.0E-05	1.8E-01
Background - Average from (Robson et al. 2013)	8.4E-07	4.9E-03

Screening Approach Used to Characterize Exposure for the Recycling of Electronics Waste Containing HIPs

EPA estimated central tendency and high-end air releases of HBCD from electronic recycling sites to be 0.024 and 0.38 kg/site-d, respectively, for a duration of 250 days. EPA compared the air release estimates for electronic recycling sites to those that were previously used to quantify HBCD soil concentration (via air deposition) for releases associated with other conditions of use (Appendix F.1.2). The daily release amounts of HBCD and number of release days estimated for electronic recycling sites fall within the range as those used to characterize and estimate soil HBCD concentrations from air deposition for other conditions of uses. Specifically, in comparison to exposure scenario 6.12, where the daily release of HBCD (3.8 kg/site-d) and number of release days (300 days) are both higher than those predicted for electronic recycling sites, the resulting soil HBCD concentration for exposure scenario 6.12 is 3.66E-03 µg/kg for fenceline communities (near industrial facilities). This exposure scenario's estimated soil concentration of HBCD does not surpass the hazard threshold for soil organisms (173,000 µg/kg). Due to the unlikelihood that the lower release amounts and days for electronic recycling sites will surpass those used for any of the other conditions of use, soil concentrations of HBCD due to air deposition were not estimated using methods outlined above in Appendix F.1.2 for the exposure scenario regarding the recycling of electronics waste containing HIPs.

2.3.3.3 Combined Soil Concentration – Air Deposition, Background, Biosolid Application

The overall magnitude of the contribution of air deposition to soil concentrations is generally low, <1 µg/kg for all scenarios considered. Further, background soil concentrations based on the soil monitoring were below 10 µg/kg. Therefore, an estimated high-end soil concentration of HBCD from all sources, including biosolids application (30 µg/kg), air deposition (1 µg/kg), and background (10 µg/kg) would be slightly higher (41 µg/kg) than potential soil concentrations from any of these individual sources.

2.3.4 Assessment of Exposure in Targeted Wildlife

There are several biomonitoring studies examining the occurrence of HBCD in a wide range of wildlife biota across multiple trophic levels. Most of the wildlife biomonitoring samples report HBCD in lipid weight, but some are reported in wet weight. Some studies describe temporal, spatial ([Esslinger et al. 2011a](#)), and trophic level ([Poma et al. 2014](#)) trends of HBCD concentrations in biota. A summary of occurrence of HBCD in aquatic and terrestrial biota is presented in Sections 4.1.1 and 4.2.1 of the *Risk Evaluation for Cyclic Aliphatic Bromide Cluster (HBCD), Supplemental Information on General*

Population, Environmental, and Consumer Exposure Assessment. Monitoring data was extracted for a variety of wildlife, including amphibians, aquatic invertebrate, aquatic mammals, birds, fish, terrestrial mammals, and vegetation.

Certain studies demonstrate that wildlife are more highly exposed when they are close to point sources *i.e.*, certain species that live near effluent discharge sites ([Haukås et al. 2010a](#)). Due to HBCD's persistence and potential for long-range transport ([UNEP 2010b](#)), exposure to wildlife is expected, at some level, to continue even as current releases to the environment decline.

2.3.5 Summary of Results for Environmental Exposure Assessment

The monitoring and modeling data presented in the preceding sections is summarized in Table 2-66. Values with an asterisk indicate that the value was carried forward to risk estimation. A comparison of the near-facility monitoring concentrations with the scenario-specific modeled concentrations based on estimated release data indicate general agreement of data. While a meta-analysis using raw data would have provided a more robust approach, raw data was generally not available for most studies.

Table 2-66. Comparison of Published Literature and Modeling Results for Concentrations of HBCD in Surface Water, Sediment, and Soil

Data Type	Environmental Media			Point Source Proximity
	Surface Water Concentration (µg/L)	Sediment Concentration (µg/kg)	Soil Concentration (µg/kg)	
Modeled Estimates				
E-FAST modeled estimates (50 th low flow)	8.3E-05 – 1.1E+02	NA	NA	Near (Scenario-Specific)
E-FAST modeled estimates (10 th low flow)	4.2E-03 – 5.3E+03	NA	NA	Near (Scenario-Specific)
VVWM-PSC modeled estimates (50 th low flow)	*21-Day Average-Dissolved: 1.1E-04 – 3.8E+00	*28-Day Average: 1.2E-01 – 1.2E+04	NA	Near (Scenario-Specific)
VVWM-PSC modeled estimates (10 th low flow)	*21-Day Average Dissolved: 9.2E-03 – 1.8E+02	*28-Day Average: 1.1E-00 – 5.7 E+05	NA	Near (Scenario-Specific)
IIOAC modeled (Deposition from air)	<1	<1	*<1	Near (Scenario-Specific)
Robson et al. (2013) (Deposition from air)	<1	<1	<1	Far
Biosolid Application	NA	NA	*30	Near
Modeled Estimates from (EC/HC 2011) - 100 m from facility	Raw Materials Handling			Near
	5.0E-01 – 1.5E+01	3.6E+03 – 1.8E+05	NA	
	Compounding			
	1.0E-01 – 1.3E+00	3.3E+02 – 9.9E+03	NA	

Modeled Estimates from (EC/HC 2011) - 5 km from facility	Raw Materials Handling			Far
	3.0E-01 – 1.0E+01	2.6E+03 – 7.7E+04	NA	
Modeled Estimates from (EC 2008)	Compounding			Near
	3.0E-02 – 9.0E-01	2.3E+02 – 7.0E+03	NA	
Monitoring Data				
All Extracted Data	High income: 2.5E-3 – 3.1E+00 (n=3) Non-high income: 6.0E-5 – 1.8E+00 (n=2)	High income: 7.5E-02 – 8.5E+04 (n=11) Non-high income: 5.0E-03 – 2.75E+04 (n=4)	High income: 1.4E+2 – 1.3E+03 (n=1) Non-high income: 5.0E-03 – 3.2E+04 (n=8)	Near
	High income: 2.0E-7 – 6.7E-03 (n=6) Non-high income: 9.5E-06 – 1.6E-03 (n=3)	High income: 2.0E-3 – 1.7E+03 (n=32) Non-high income: 2.0E-03 – 1.0E+03 (n=13)	High income: 1.8E-1 – 1.0E+2 (n=3) Non-high income: 4.0E-03 – 1.7E+03 (n=14)	Far
Final Extracted Dataset (following statistical analysis procedures)	High income: 2.5E-3 – 3.1E+00 (n=3) *CT: 8.4E-01 *HE: 9.9E-01	High income: 5.0E-01 – 8.5E+04 (n=6) *CT: 3.4E+03 *HE: 5.1E+03	High income: 1.4E+2 – 1.3E+3 (n=1) *CT: 1.0E+03 *HE: 1.3E+03	Near
	High income: 2.0E-7 – 6.7E-03 (n=4) *CT: 4.1E-04 *HE: 8.0E-04	High income: 2.2E-2 – 1.7E+03 (n=14) *CT: 6.0E+00 *HE: 2.0E+01	High income: 1.8E-1 – 1.2E+01 (n=2) *CT: 1.4E+00 *HE: 3.0E+00	Far

Asterisk (*) indicates values used in exposure estimates for risk estimation
NA = not available; CT = central tendency; HE = high-end

2.3.6 Sensitivity Analysis – Environmental Exposure

2.3.6.1 Modeled Sediment

For estimated sediment concentrations from VVWM-PSC (Section 2.3.2.2.2), the default values, such as suspended sediment concentration, fraction organic content, chlorophyll, and biomass content also influence distribution. A targeted sensitivity analysis showed that K_{oc} , half-life in sediment, fraction organic content, and suspended solids concentration are parameters that tend to have more of an impact on sediment concentrations. EPA considered variation of some of the more sensitive parameters, but found that results using different inputs, showed similar magnitude and trends as the results presented. This is likely because changes in of multiple parameters may have offset the impact of other parameters.

2.3.6.2 Monitoring Data (General)

Table 2-67 summarizes the sensitivity analysis associated with monitoring data. Potential variability in the assumption that the central tendency estimate of the reported monitoring data represent the geometric mean appear to have a limited impact on the estimate of the high-end (95th percentile) dose. Increasing the geometric mean by 10% over the baseline value increased high-end dose by 4%, while decreasing it by 10% decreased dose by 7%.

Table 2-67. Sensitivity Analysis of Central Tendency Estimate Assumptions in Monitoring Data

	Estimated Dose in mg/kg/day		
	Baseline GM	Baseline GM + 10%	Baseline GM - 10%
95 th Percentile Dose	3.1E-04	3.2E-04	2.9E-04
% Change from Baseline	--	4%	-7%

GM = geometric mean

2.3.6.3 Fish Tissue

For fish tissue concentrations (Section 2.4.2), a wide range of BCF and BAF values are available in the literature. Generally, BCF and BAF values are highly sensitive to variability in measured input values (dissolved surface water concentration, lipid weight fish tissue concentration, and fraction lipid-content). Small changes in these input values can result in large changes in associated BCF and BAF values.

2.3.6.4 Scenario Inputs (product amount, WWTR%)

As described in Section 2.2.15, EPA performed sensitivity analyses for three conditions of use at the per site process volumes of 50,000 lbs/yr and 25,000 lbs/yr to examine the effect of process volume on the resulting general population and environmental exposures. In addition, EPA chose to perform additional sensitivity analyses by incorporating a higher onsite (direct release) wastewater removal when the removal rates were unknown. For Scenario 1 (Repackaging of Import Containers), based on information provided in Section 2.2.2, EPA applied 90% removal for releases to water. As mentioned in Section 2.3.2, when information regarding pretreatment for direct releases to surface was uncertain, EPA applied a removal rate of 0%. In the sensitivity analysis presented here, a tiered approach was used to assess these releases using both 0% removal and a higher removal rate.

Little information was found on the type or efficiency of onsite treatment used by direct discharging facilities using HBCD. Due to its low water solubility (66 µg/L), high log K_{ow} (5.6) and physical state (solid), HBCD is likely to partition to the organic phase, including organic particulates such as activated sludge in biological wastewater treatment systems. At concentrations above its water solubility it is expected to behave as a particulate in aqueous wastewater and be removed with other solids by gravity settling during the wastewater clarification process. The efficiency of removal of HBCD may be reflected in data for total suspended solids (TSS) removal.

HBCD processing and use activities described in this Risk Evaluation may be subject to the Organic Chemicals and Plastics and Synthetic Fibers (OCPSF) Category Effluent Limitations Guidelines, Pretreatment Standards, and New Source Performance Standards 40 CFR Parts 414 and 416 [FRL 3230-5]. The OCPSF limitations and standards establish effluent limitations guidelines and standards that limit the discharge of pollutants into navigable waters and publicly owned treatment works (POTWs) by existing and new sources in the Organic Chemicals, Plastics, and Synthetic Fibers (OCPSF) industrial category. End-of-pipe biological treatment direct dischargers who are subject to subpart E of the regulations must meet relevant discharge limits of priority pollutants. A facility may meet their limits by virtue of the absence of a regulated pollutant in their process wastewater as confirmed by monitoring, or the use of engineering controls or installation of end-of-pipe biological treatment. Where present and properly maintained and operated, this type of treatment has been shown to remove chemicals with similar tendency to sorb to sludge as that of HBCD (log Kow 5.6), examples include benz(a)anthracene (log Kow 5.8), benz(a) pyrene (log Kow 6.1), and fluoranthene (log Kow 5.8). The EPA Development Document for Effluent Limitations, Guidelines and Standards for Organic Chemicals, Plastics and Synthetic Fibers Point Source Category ([U.S. EPA 1987](#)) reported that the majority of the facilities in the OCPSF category responding to the EPA 308 survey reported using the activated sludge treatment process to treat their process wastewater. TSS removal in activated sludge treatment was reported by the responding facilities with a of mean (67%), a median (81%), a minimum (-29%) and a maximum (99%) for thirty nine observations.

HBCD may be released to wastewater incorporated into polystyrene particles. These particles may fall into the range of “microplastics” <5 mm in diameter ([Conley et al. 2019](#)). A number of studies have demonstrated high removal of HBCD and microplastics in activated sludge treatment ([Conley et al. 2019](#)). determined the microplastic (synthetic polymer materials <5mm in size) loads and removal efficiencies of three activated sludge wastewater treatment plants (WWTPs) with different treatment sizes, operations and service compositions discharging to Charleston Harbor, South Carolina, over the course of a year. Microplastics concentrations (counts per L) varied within a factor of 2.5 in influent and 4.8 in effluent at each WWTP, and that neither concentrations nor removal efficiencies demonstrated a seasonal trend. The largest wastewater treatment plant in the study, which also employed primary clarification, had the highest MP removal efficiency of $97.6 \pm 1.2\%$. The other two smaller facilities had average removal efficiencies of $85.2 \pm 6.0\%$ and $85.5 \pm 9.1\%$. Ruan ([Ruan et al. 2019](#)) investigated the removal of microplastics and HBCD levels in microplastics at two Hong Kong wastewater treatment plants. One plant employed primary treatment while the second plant utilized secondary treatment. Greater than 90% removal of HBCD was observed in both plants. Approximately 60% and 87% removal of microplastics occurred in the primary and secondary treatment systems, respectively.

Sun ([Sun et al. 2019](#)) conducted a comprehensive review of studies on the detection, occurrence and removal of microplastics in WWTPs. The review included techniques used for collecting microplastics from both wastewater and sewage sludge, and their pretreatment and characterization methods. Microplastics removal in various stages of wastewater treatment and their retention in sewage sludge were explored. Overall percent removals in secondary wastewater treatment from 7 studies conducted in the U.S. and Europe were reported. Microplastics removal efficiencies ranged from 72 to 99% with a mean value across all the studies of removal in secondary treatment of 92%. Carr ([Carr et al. 2016](#)) conducted microplastics bench scale wastewater treatment simulations and studied effluent discharges from seven tertiary and one secondary wastewater treatment plant in Southern California to determine the fate of microplastics in these systems. The results of bench scale experiments with activated sludge and raw wastewater, simulated high solids influent and gravity filtration suggested that the buoyancy of

microplastics facilitates removal by surface skimming, entrapment in influent suspended solids facilitates removal by solids settling, and high retention of microplastics on typical gravity bed filter materials leads to potential for high removal in secondary and tertiary wastewater treatment. Analysis of influent and effluent samples for microplastic particles at both secondary and tertiary treatment plants indicated removal $\geq 99\%$.

EPA considered these reported values and uncertainty in extrapolating from performance of the treatment systems surveyed in the Effluent Guidelines document to those facilities using HBCD. EPA also considered uncertainty associated with the use of TSS removal and microplastics removal as a surrogate for HBCD removal. EPA selected 90% removal of HBCD in wastewater treatment for direct dischargers. EPA is confident that some removal of HBCD will occur in onsite wastewater treatment. Higher or lower removal of HBCD could occur based on the type of treatment employed and its performance optimization.

EPA acknowledges the downward trend of environmental releases as the production volume of HBCD has decreased over time. To account for this, EPA considered three separate estimates of releases for conditions of use based on three different production volumes: 100,000, 50,000, and 25,000 kilograms per year. EPA estimated surface water and sediment concentrations through the Point Source Calculator for all combinations. EPA inferred that the days of release correlated with kg/site/day releases. For example, as total releases decrease, the number of days of release also decrease. For this reason, any 1-day surface water concentrations are approximately equal. Both the overall magnitude of the release and the number of days of release influence estimated concentrations. When the overall magnitude of the release is reduced by a factor of two or four, the corresponding environmental concentration is also reduced by approximately a factor of two or four. When the number of days are reduced by factor of two or four, the corresponding environmental concentration is reduced, however, the trend is not linear and depends on the number of days of release. This is due to uncertainty in the timing of the release days and the selected averaging periods (21-days for surface water and 28 days for sediment), 21-day average water concentrations and 28-day average sediment concentrations are more sensitive to changes in release estimates. EPA inferred that the release days occur intermittently rather than continuously through the year. The timing of these releases, in addition to the number of release days, influence potential exposure concentrations. EPA also varied other parameters in its surface water modeling that have a large impact on estimated results. The selected flow values for mean-flow or low flow are highly sensitive. EPA used a central tendency and a high-end estimate for each of these flow metrics. Estimated sediment concentrations are highly sensitive to the sediment half-life used; hence, EPA used central tendency and high-end estimates for sediment half-life in calculating sediment concentrations. Because the percent removal of HBCD from different removal processes is likely variable, EPA also varied percent removal expected based on three scenarios: on-site treatment (pre-treatment) [0%] and on-site wastewater treatment plants [90%]. Some release estimates already account for treatment while others do not. The efficiency of treatment across different industrial facilities and different wastewater treatment plants will also vary.

Table 2-68. Summary of HBCD Surface Water Concentrations from Sensitivity Analysis: Varying Production Volume and Waste Water Treatment Removal– Environmental Exposures

SCENARIO NAME	Production Volume (lbs / year)	% WWTP Removal for Direct Releases ^a	Surface Water 1-Day Average Concentration Range (ug/L)		Sediment	
			Acute: 50 th %-ile	Chronic: 50 th %-ile	11-d half-life: 50 th %-ile	128-d half-life: 50 th %-ile
Scenario 1. Import and Re-packaging/ Processing: Repackaging of Import Containers	100,000	90%	3.7E-02 - 9.7E+00	3.0E-02 - 9.4E-01	3.4E+01 - 8.7E+02	7.7E+01 - 2.0E+03
	50,000	90%	3.7E-02 - 9.4E+00	1.8E-02 - 5.0E-01	1.9E+01 - 5.4E+02	4.1E+01 - 1.2E+03
	25,000	90%	3.7E-02 - 1.0E+01	8.8E-03 - 4.8E-01	8.5E+00 - 3.2E+02	1.9E+01 - 6.3E+02
Scenario 3. Processing: Manufacturing of XPS Foam using XPS Masterbatch	100,000	0%	8.0E-03 - 2.9E+00	3.8E-04 - 1.4E-01	4.0E-01 - 8.9E+01	8.9E-01 - 1.2E+02
	50,000	0%	4.0E-03 - 1.5E+00	1.9E-04 - 7.1E-02	2.0E-01 - 4.5E+01	4.4E-01 - 6.0E+01
	25,000	0%	2.0E-03 - 7.4E-01	3.8E-04 - 1.4E-01	1.0E-01 - 2.3E+01	2.2E-01 - 3.0E+01
Scenario 5. Processing: Manufacturing of EPS Foam from Imported EPS Resin Beads	100,000	0%	8.8E-01 - 1.1E+02	2.9E-01 - 5.0E+00	3.3E+02 - 5.5E+03	7.6E+02 - 1.2E+04
	50,000	0%	4.4E-01 - 1.1E+02	1.5E-01 - 5.0E+00	1.7E+02 - 3.5E+03	3.8E+02 - 6.9E+03
	25,000	0%	2.2E-01 - 1.1E+02	7.4E-02 - 5.0E+00	8.4E+01 - 3.2E+03	1.9E+02 - 4.9E+03

^a There are no predicted direct releases for Scenario 1.

2.3.7 Assumptions and Key Sources of Uncertainty in Environmental Exposure Assessment

Concentrations of HBCD in environmental and biological media are expected to vary. Close proximity to facilities and other sources is likely to lead to elevated concentrations compared to locations which are more remote. A combination of monitoring data from the U.S. and international sources were used in this exposure assessment. In addition, monitoring data were collected in previous years when production volume and associated releases of HBCD into the environment are expected to have been higher than they are currently and expected to be in the future. When considering older monitoring data and monitoring data from international sources, there are uncertainties associated with using these data because it is unknown whether those sampling sites are representative of current sites within the U.S.

In modeling environmental concentrations of HBCD, EPA acknowledges the conservative nature of the E-FAST model and the additional refinement provided by the PSC model. Water dilution models can be used to determine the concentration of a chemical in the surface water after a source emits the chemical into a water body. Since the E-FAST model default values encompass either a combination of upper percentile and mean exposure parametric values, or all upper percentile parametric values, the resulting model predictions represent high-end exposures estimates. A simple dilution model, such as EFAST, provides exposure estimates that are derived from a simple mass balance approach, and does not account for partitioning between compartments within a surface water body or degradation over time in different media, parameters which are relevant to HBCD. For these reasons, EPA utilized a two-tier approach by complementing the EFAST modeling with more refined estimates from the PSC model to further describe environmental exposures.

When modeling using E-FAST, EPA assumed that primary treatment removal at POTWs occurred with 90% removal efficiency, however for direct discharges, EPA used 0% removal. EPA recognizes that this is a conservative assumption that results in no removal of HBCD prior to release to surface water. This assumption will give higher surface water and sediment concentrations compared to a removal efficiency of 75 or 90% removal. This assumption reflects both the uncertainty of the type of wastewater treatment that may be in use at a direct discharging facility and the HBCD removal efficiency in that treatment. It is likely that under the COUs for HBCD, a facility's wastewater discharge is required to meet NPDES discharge permit limits for total suspended solids, five-day biochemical oxygen demand (BOD₅) and other wastewater treatment parameters. Treatment methods used to meet the limits (such as activated sludge treatment) will likely also remove HBCD from wastewater to an uncertain, but non-zero, extent due to the properties of HBCD.

EPA used a combination of chemical-specific parameters and generic default parameters when estimating surface water, sediment, soil, and fish-tissue concentrations. For estimated soil concentrations from biosolid application, specifically, EPA recognizes that different default parameters for tillage depth and application rates are used by other U.S. agencies which may result in concentrations of a higher magnitude. However, EPA used both central tendency and high-end values across model inputs to characterize the variability within and across scenarios. EPA also used central tendency and high-end model outputs. Comparison of model outputs with monitored values offers one way to ground-truth the combination of model inputs and outputs used. EPA compared monitoring and modeled surface water, sediment, soil, and fish-tissue concentration estimates. Estimates of fish-tissue concentrations are further discussed in Section 2.4.3. In summary, EPA compared monitored and modeled fish tissue concentrations using modeled 21-day average dissolved water concentrations and low-end BAF values and found overlap and concordance between these values and fish-tissue monitoring data. When

modeling the HBCD concentrations in water and sediment, EPA did not consider the potential impact of persistence and longer-term sinks in lake and estuary environments.

Recent and future estimated levels of HBCD in the area may be lower than past levels due to reported reductions in releases over time. EPA assessed more recent releases. The predicted concentrations may be lower than concentrations that consider more years of releases or releases associated with higher production volumes.

2.4 Human Exposures

EPA considered four different receptor groups for the human exposure assessment: occupational, general population, highly exposed, and consumers. The receptor groups were defined as:

- Occupational include individuals who work at a facility handling HBCD (workers) and occupational non-users (ONU) who do not directly handle the chemical but perform work in an area where the chemical is present.
- General population include individuals who are not expected to live close to point sources of HBCD (far-field) and do not have a specific HBCD source within a living environment that has been assessed by EPA in the consumer exposure assessment (*i.e.*, home insulation, auto-components, mouthing of recycled products). The general population experiences steady-state chronic exposures resulting in risk from sustained background exposure in the environment due to HBCD persistence.
- Highly exposed include individuals who are expected to live close by point sources of HBCD.
- Consumers include individuals who have articles containing HBCD in their homes or automobiles.

A slightly different approach was used for each receptor group based on the exposure media/pathways and available data. It is possible for an individual to fall into multiple receptor and potentially exposed groups.

For all receptor groups, except general population, EPA developed scenario specific exposure estimates based on condition of use (COU) release estimates described in Section 2.2. These exposures occur at or near point sources (*i.e.*, facilities that process, use, or dispose of HBCD or HBCD-containing materials) or involve the use of articles containing HBCD. General population exposures estimates are non-scenario specific in that they are based on media concentrations not related to a specific COU release estimate (*i.e.*, background or far from facility releases). HBCD exposures to the general population may be variable as they are influenced by both sources into the environment, degradation and removal from the environment. Estimates of general population exposures based on environmental monitoring and biomonitoring data represent the conditions present at the time the data was collected. It is unknown which combination of potential sources associated with conditions of use as described in this risk assessment contribute to the monitoring data presented here. However, given the wide range of exposures shown within and across the monitoring data, there is a plausible contribution from some of the sources/conditions of use described within this document. Scenario-specific modeled releases for individual exposure pathways (*e.g.*, *fish ingestion*) were added to the aggregate background exposure from all other pathways (*i.e.*, *all exposure pathways except fish ingestion*). Exposures were not aggregated within a particular exposure route across both biomonitored and modeled estimates.

Figure 2-2 shows the exposure pathways/media identified for each receptor group, and the assessment approaches are further shown in Table 2-69.





 Occupational	 General Population	 Highly Exposed	 Consumers
At Facility	Far from Facility/Background	Near Facility	Near Consumer Products
Scenario Specific	Non-Scenario Specific	Scenario Specific	Scenario Specific
Inhalation Dermal	Ingestion: Diet, Dust & Soil Inhalation: Indoor & Outdoor Air Dermal	Ingestion: Fish Inhalation: Indoor Air	Inhalation: Indoor Air Ingestion: Dust & Mousing Recycled Articles

Figure 2-2. Overview of receptor groups considered within the Risk Evaluation.

Table 2-69. Exposure Scenarios Descriptions for Receptor Groups

Scenario	Receptor Group	Source	Pathway	Media	Approach	Approach Description
OES 1-13	Worker	HBCD	Inhalation Dermal	Indoor Air/Personal Air	Quantitative	Monitoring, Modeling, Occupational Exposure Limits
OES 1-13	ONU	HBCD	Inhalation Dermal	Indoor Air/Personal Air	Qualitative	Not Applicable
G1	General Population	HBCD	Ingestion Inhalation Dermal	Diet, Dust, Soil, Indoor Air, Outdoor Air	Quantitative	Monitoring: Indirect Estimation and Exposure Reconstruction
H1	Highly Exposed	HBCD emitted from any point source during its lifecycle from Scenarios described in Section 2.2	Ingestion	Fish Tissue: Emission into water and uptake into fish tissue	Quantitative	Modeling with PSC combined with and Lipid Normalized Upper Trophic Level BAF (monitoring), Monitoring
H2	Highly Exposed	HBCD emitted from any point source during its lifecycle from Scenarios described in Section 2.2	Inhalation	Air: Emission to air and subsequent inhalation of particles	Quantitative	Modeling with IIOAC
C1	Consumers	XPS/EPS insulation in residences	Inhalation	Indoor Air and Dust: Emission from insulation into indoor air and settled dust	Quantitative	Modeling with IECCU
C2	Consumers	HBCD contained in automobile components	Inhalation	Indoor Air and Dust: Emission into automobile cabin air and settled dust	Quantitative	Modeling with IECCU

Scenario	Receptor Group	Source	Pathway	Media	Approach	Approach Description
C3	Consumers	Recycled consumer articles that contain HBCD	Ingestion	Articles: Mouthing, direct contact	Quantitative	Monitoring and Modeled
Q1	Highly Exposed	EPS and XPS insulation in buildings during use	Inhalation	Air: Emission from building interior to ambient air surrounding buildings	Qualitative	N/A
Q2	Highly Exposed Birds	HBCD sent to landfill across the lifecycle	Inhalation Ingestion	Air, Soil, Water: Comingled HBCD containing materials leach into soil, disposed food, and water	Qualitative	N/A

Occupational receptors are discussed first in Section 2.4.1. The section contains a detailed methodology and approach for the enumeration of worker and ONUs, estimates of central and high-end inhalation and dermal exposure for each of the thirteen conditions of use. EPA assessed exposure to male and female workers including female workers of reproductive age of > 16 years to less than 50 years old, including adolescents (16 to <21 years old). Adolescents are a small part of the total workforce ([U.S. BLS, 2017](#)).

Non-occupational receptors are discussed in Sections 2.4.2 (general population), Section 2.4.3 (highly exposed), and Section 2.4.4 (consumer). Scenarios which were only qualitatively assessed are discussed in Section 2.5.5. EPA assessed exposure to seven age groups, as appropriate: <1 year, 1-<2 years, 2-<3 years, 3-<6 years, 6-<11 years, 11-<16 years, and 16-<70 years. Although the number of non-occupational individuals have not been enumerated, general population exposure estimates are expected to be relevant for more people in the general population, whereas estimates of exposure for highly-exposed groups likely apply to relatively fewer individuals.

For all non-occupational exposure groups, EPA estimated exposures using EPA exposure factors when available, some of which were recently updated ([U.S. EPA 2011b](#)). EPA acknowledges that some exposure factors for highly-exposed groups could be higher than the general population. EPA acknowledges that there could be further refinement of highly exposed (high-end) and potentially exposed or susceptible subpopulations (PESS) as receptor categories overlap and individuals may belong to multiple receptor groups. Further discussion of qualitative and semi-quantitative examples of highly exposed and susceptible subpopulations is also provided in Section 4.4.1.

EPA notes that should sources emitted from industrial facilities continue to decline, over time exposures near these facilities could likely trend towards general population exposures. Recently, manufacturers of HBCD indicated that production of HBCD in the United States has ceased as discussed in Section 1.2.2. Since the initiation of this Risk Evaluation period in December 2016, HBCD may still be imported into the United States and handled by processing facilities. However, the amount of HBCD and the uses of HBCD in the United States may be lower when compared to past amounts and uses. Therefore, exposure potential in the future may be lower than the past. EPA has included a discussion of observed trends in monitoring data and has noted observed trends with estimated releases to the environment. While both trends suggest reduced sources of HBCD in the environment, HBCD's persistence and the potential for long-range transport, coupled with extended shelf-life of HBCD-containing articles in buildings and

recycling of these same articles throughout the United States suggest that there may be a continuing sources for emission of HBCD extending into the future.

2.4.1 Occupational Exposures

EPA assessed workplace exposures pertaining to the following HBCD exposure scenarios:

- Repackaging of Import Containers
- Compounding of Polystyrene Resin to Produce XPS Masterbatch
- Processing of HBCD to Produce XPS Foam using XPS Masterbatch
- Processing of HBCD to Produce XPS Foam using HBCD powder
- Processing of HBCD to Produce EPS Foam from Imported EPS Resin Beads
- Processing of HBCD to Produce SIPs and Automobile Replacement Parts from XPS/EPS Foam
- Use: Installation of Automobile Replacement Parts
- Use: Installation of XPS/EPS Foam Insulation in Residential, Public and Commercial Buildings, and Other Structures
- Demolition and Disposal of XPS/EPS Foam Insulation Products in Residential, Public and Commercial Buildings, and Other Structures
- Recycling of EPS Foam and Reuse of XPS Foam
- Formulation of Flux/Solder Pastes
- Use of Flux/Solder Pastes
- Recycling of Electronics Waste (E-Waste) Containing HIPS

Components of the Occupational Exposure Assessment

The occupational exposure of each exposure scenario comprises the following components:

1. **Number of Workers and Occupational Non-Users:** An estimate of the number of workers and occupational non-users (-workers, who do not directly handle the chemical but perform work in an area where the chemical is present) potentially exposed to the chemical for the given exposure scenario.
2. **Inhalation Exposure:** Central tendency and high-end estimates of inhalation exposure to workers and occupational non-users. EPA assumes that all inhaled particulates are absorbed by either the lung or intestine after ingestion as further discussed in Section 4.2.1.
3. **Dermal Exposure:** Estimates of dermal exposure to workers.

The process descriptions and facility estimates are included in Section 2.2 for each exposure scenario.

2.4.1.1 Occupational Exposures Approach and Methodology

Number of Workers and ONUs

Where available, EPA prefers to use CDR data to provide a basis to estimate the number of workers and occupational non-users (ONUs). However, all companies that have historically reported HBCD manufacturing and importation to CDR have ceased such operations. In lieu of current CDR data, EPA used U.S. economic data to estimate the number of workers and ONUs using the following method:

- Identify the North American Industry Classification System (NAICS) codes for the industry sectors associated with each exposure scenario.
- Estimate total employment by industry/occupation combination using the Bureau of Labor Statistics' Occupational Employment Statistics data ([U.S. BLS 2016](#)).
- Refine the occupational employment statistics estimates where they are not sufficiently granular by using the U.S. Census' (2015) Statistics of U.S. Businesses (SUSB) data on total employment by 6-digit NAICS.
- Estimate the number of potentially exposed employees per site ([Census Bureau 2015](#)).

- Estimate the number of potentially exposed employees within the exposure scenario, using the number of sites estimated as described in Section 2.2.1.

EPA discussed the estimation of HBCD throughput and number of sites in Section 2.2.1.

EPA's General Approach to the Assessment of Inhalation Exposure

EPA provided occupational exposure results representative of central tendency conditions and high-end conditions. A central tendency is assumed to be representative of occupational exposures in the center of the distribution for a given exposure scenario. For Risk Evaluation, EPA may use the 50th percentile (median), mean (arithmetic or geometric), mode, or midpoint values of a distribution as representative of the central tendency scenario. EPA's preference is to provide the 50th percentile of the distribution. However, if the full distribution is not known, EPA may assume that the mean, mode, or midpoint of the distribution represents the central tendency depending on the statistics reported in the data source for the distribution.

A high-end is assumed to be representative of occupational exposures that occur at probabilities above the 90th percentile but below the exposure of the individual with the highest exposure ([U.S. EPA, 1992](#)). For Risk Evaluation, EPA plans to provide high-end results at the 95th percentile. If the 95th percentile is not available, EPA may use a different percentile greater than or equal to the 90th percentile but less than or equal to the 99.9th percentile, depending on the statistics available for the distribution. If the full distribution is not known and the preferred statistics are not available, EPA may estimate a maximum or bounding estimate in lieu of the high-end.

Exposures are calculated from datasets, comprised of data from one or more sources, depending on the size of the dataset. For datasets with six or more data points, central tendency and high-end exposures were estimated using the 50th percentile and 95th percentile. For datasets with three to five data points, central tendency exposure was calculated using the 50th percentile and the maximum was presented as the high-end exposure estimate. For datasets with two data points, the midpoint was presented as a midpoint value and the higher of the two values was presented as a higher value. Finally, data sets with only one data point presented the value as a what-if exposure. EPA did not have discrete data points for the discussed monitoring data in this section. Only statistical summaries of the data sets were available, and EPA did not combine or perform calculations with these reported statistics.

EPA follows the following hierarchy in selecting data and approaches for assessing inhalation exposures:

1. Monitoring data:
 - a. Personal and directly applicable
 - b. Area and directly applicable
 - c. Personal and potentially applicable or similar
 - d. Area and potentially applicable or similar
2. Modeling approaches:
 - a. Surrogate monitoring data
 - b. Fundamental modeling approaches
 - c. Statistical regression modeling approaches
3. Occupational exposure limits:

- a. Company-specific occupational exposure limits (OELs) (for site-specific exposure assessments, *e.g.*, there is only one processing site who provides to EPA their internal OEL but does not provide monitoring data)
- b. OSHA permissible exposure limit (PEL)
- c. Voluntary limits (American Conference of Governmental Industrial Hygienists [ACGIH] threshold limit value [TLV], NIOSH recommended exposure limit [REL], Occupational Alliance for Risk Science [OARS] workplace environmental exposure level (WEEL) [formerly by AIHA])

For occupational exposures, EPA used measured air concentrations, estimated air concentrations, or occupational exposure limits to calculate exposure concentration metrics required for Risk Evaluation. Specifically, EPA used these exposure concentration values to calculate acute exposure dose (AED) and average daily dose (ADD). Additional explanation of the equations used to calculate AED and ADD, and example calculations are located in Appendix E.3 and Appendix E.4, respectively. EPA then multiplied the AED and ADD by the inhalation absorption factor of 100% (discussed in Section 3.2.2) to estimate the acute absorbed dose (AAD) and chronic absorbed dose (CAD), respectively. The AED and AAD are used to assess acute exposure risks. The ADD and CAD are used to assess chronic, non-cancer risks. These calculations require additional parameter inputs, such as years of exposure, exposure duration and frequency, and lifetime years.

For the final exposure result metrics, each of the input parameters (*e.g.*, air concentrations, working years, exposure frequency, lifetime years) may be a point estimate (*i.e.*, a single descriptor or statistic, such as central tendency or high-end) or a full distribution. EPA will consider three general approaches for estimating the final exposure result metrics:

Deterministic calculations: EPA will use combinations of point estimates of each parameter to estimate a central tendency and high-end for each final exposure metric result. EPA will document the method and rationale for selecting parametric combinations to be representative of central tendency and high-end.

Probabilistic (stochastic) calculations: EPA will pursue Monte Carlo simulations using the full distribution of each parameter to calculate a full distribution of the final exposure metric results and selecting the 50th and 95th percentiles of this resulting distribution as the central tendency and high-end, respectively.

Combination of deterministic and probabilistic calculations: EPA may have full distributions for some parameters but point estimates of the remaining parameters. For example, EPA may pursue Monte Carlo modeling to estimate exposure concentrations, but only have point estimates of working years of exposure, exposure duration and frequency, and lifetime years. In this case, EPA will document the approach and rationale for combining point estimates with distribution results for estimating central tendency and high-end results.

EPA's determination of each of the input parameters for calculation of AED and ADD are explained in Appendix E.3.

EPA quantitatively assessed exposure to male and female workers including female workers of reproductive age of > 16 years to < 50 years old, which includes adolescents (16 to <21 years old). Male adolescent workers are also potentially exposed to HBCD and their exposure dose (mg/kg-day) is in the range assessed as their dose would be between estimates for average workers and female workers.

Adolescents (16 to < 21 years old) are a small part of the total workforce in the workplace ([U.S. BLS, 2017](#)).

EPA's Approach to the Assessment of HBCD Inhalation Exposure

EPA gathered and evaluated occupational exposure information in accordance with the process described in the *Application of Systematic Review in TSCA Risk Evaluations* ([U.S. EPA 2018b](#)). The results of EPA's systematic review include occupational monitoring data pertaining to the manufacture and processing of HBCD in Europe. These data, which are presented in Appendix Appendix E, are HBCD inhalation exposure concentration monitoring data pertaining to the manufacture and processing of various grades of HBCD and include various types of data (*e.g.*, personal breathing zone, area monitoring, 8-hr TWA, etc.). The main source of these data is the European Union Risk Assessment Report (EURAR) ([NICNAS 2012b](#); [ECHA 2008b](#)). From these data, EPA selected particular data to estimate worker inhalation exposure concentrations as discussed in Sections 2.4.1.2 through 2.4.1.13. The overall quality confidence rating of all the data that EPA selected is high as determined by EPA's systematic review. Table 2-70 contains a summary of EPA's approaches to the assessment of worker inhalation exposure concentrations, and includes mention of the industrial processes and worker activities that the selected worker monitoring data pertain to. The occupational monitoring data comprise of HBCD concentrations in inhalable and respirable dust. EPA assessed worker exposure to inhalable dust only and EPA's rationale for doing so is discussed in Section 4.2.1. A breathing rate of 1.25 m³/hr was applied for all workers, representing elevated respiratory rate compared to at rest for workers undergoing light activity ([U.S. EPA 2011b](#)). For each exposure scenario, EPA calculated acute and chronic exposures from the estimated inhalation exposure concentrations. Equations and sample calculations for acute and chronic exposures can be found in Appendix E.3 and Appendix E.4, respectively.

In addition to the data mentioned above, the results of EPA's systematic review also include air concentration data pertaining to the thermal cutting of XPS/EPS foam. As discussed in Sections 2.4.1.6, 2.4.1.7, and 2.4.1.9, XPS/EPS foam may be thermally cut with a hot wire during the processing of HBCD to produce EPS foam from imported EPS resin beads, during the manufacture of SIPs and auto parts from XPS/EPS foam and during the installation of XPS/EPS in buildings and other structures. Zhang et al. ([2012](#)) reported the release of HBCD nanoparticles during the thermal cutting of XPS foam and EPS foam in a laboratory glovebox. The HBCD that was released was mostly particles (99.9%) and only a very small fraction was released as a vapor. The released particles were composed of HBCD and other chemicals and included liquid particles and polystyrene foam fragments. The distribution of HBCD concentration versus particle size of the released particles has a geometric mean of 237 and 150 nm for XPS and EPS, respectively, and geometric standard deviation of 2.2 and 1.9 for XPS and EPS, respectively. The average concentration of XPS and EPS in the glovebox was 0.089 mg/m³ and 0.057 mg/m³, respectively. EPA did not incorporate these HBCD air concentration data into the estimates of exposure concentrations of the relevant exposure scenarios because these data are measurements of concentration in a laboratory glovebox and are not occupational monitoring data.

Table 2-70. Summary of Inhalation Exposure Assessment Approaches

Relevant Report Section	Exposure Scenario	Approach to the Assessment of HBCD Potential Inhalation Exposure Concentrations
Section 2.4.1.2	Repackaging of Import Containers	EPA estimated the inhalation exposure concentrations to be equal to surrogate HBCD worker inhalation exposure concentration monitoring data. These surrogate data are worker monitoring data that pertain to various worker activities during the manufacturing of

Relevant Report Section	Exposure Scenario	Approach to the Assessment of HBCD Potential Inhalation Exposure Concentrations
		HBCD in Europe. The worker activities include packaging and working in a warehouse.
Section 2.4.1.3	Compounding of Polystyrene Resin to Produce XPS Masterbatch	In the case of the exposure scenarios of the Compounding of Polystyrene Resin to Produce XPS Masterbatch and the Processing of HBCD to Produce XPS Foam Using HBCD Powder, EPA found inhalation exposure concentration monitoring data pertaining to the exposure scenario, but did not incorporate these data into the estimates of inhalation exposure concentrations because these data are not the preferred type. In the case of all of the three exposure scenarios, EPA estimated inhalation exposure concentrations to be equal to the assessed exposure concentrations reported in the EURAR (ECHA 2008b) that pertain to all polymer processing operations involving standard grade HBCD. The bases of these assessed exposure concentrations of the EURAR are HBCD inhalation exposure concentration monitoring data that pertain to the manufacture of EPS resin beads and are surrogate data for the three exposure scenarios mentioned in the column to the left. These are surrogate data because these data pertain to the manual addition of HBCD to process equipment.
Section 2.4.1.5	Processing of HBCD to Produce XPS Foam Using HBCD Powder	
Section 2.4.1.12	Formulation of Flux/Solder Pastes	
Section 2.4.1.4	Processing of HBCD to Produce XPS Foam using XPS Masterbatch	EPA estimated inhalation exposure concentrations to be equal to inhalation exposure concentration monitoring data that pertain to this exposure scenario. These monitoring data pertain specifically to the secondary processing of XPS in Europe which EPA assumed comprises cutting, sawing and/or machining of XPS foam.
Section 2.4.1.6	Processing of HBCD to Produce EPS Foam from Imported EPS Resin Beads	EPA estimated the inhalation exposure concentrations of all these exposure scenarios to be equal to surrogate HBCD worker inhalation exposure concentration monitoring data. The surrogate data pertain to the secondary processing of XPS as a part of the manufacture of XPS foam at sites in Europe. EPA assumed the secondary processing of XPS foam comprises cutting, sawing and/or machining of XPS foam. EPA's single estimate of inhalation exposure concentrations is applicable to all four scenarios.
Section 2.4.1.7	Processing of HBCD to Produce SIPs and Automobile Replacement Parts from XPS/EPS Foam	
Section 2.4.1.9	Use: Installation of XPS/EPS Foam Insulation in Residential, Public and Commercial Buildings, and Other Structures	
Section 2.4.1.11	Recycling of EPS Foam and Reuse of XPS foam	
Section 2.4.1.10	Demolition and Disposal of XPS/EPS Foam Insulation Products in Residential, Public and Commercial	EPA estimated inhalation exposure concentrations to be equal to the Occupational Safety and Health Administration (OSHA) permissible exposure limit (PEL) for particulates not otherwise regulated (PNOR) multiplied by the HBCD concentrations in XPS and EPS foam.

Relevant Report Section	Exposure Scenario	Approach to the Assessment of HBCD Potential Inhalation Exposure Concentrations
	Buildings, and Other Structures	
Section 2.4.1.8	Use: Installation of Automobile Replacement Parts	EPA does not expect these exposure scenarios to result in the generation of dust, hence EPA does not estimate inhalation exposures.
Section 2.4.1.13	Use of Flux/Solder Pastes	
Section 2.4.1.14	Recycling of Electronics Waste (E-Waste) Containing HIPS	EPA estimated inhalation exposure concentrations to be equal to inhalation exposure concentration monitoring data that pertain to this exposure scenario. Specifically, these monitoring data pertain to the recycling of e-waste in Europe.

EPA expects potential inhalation exposure of occupational non-users (ONUs) to HBCD, but EPA did not quantify these exposures due to lack of adequate worker monitoring data and lack of relevant mathematical models. ONUs are workers such as supervisors who work in or near areas where HBCD is handled or processed, but whose work is not directly associated with HBCD. EPA expects that dust containing HBCD that is generated during worker activities may be transported via indoor air or ambient air currents to locations in which ONUs are present. The worker monitoring data identified through EPA's systematic review process are presented in Appendix Appendix E, Inhalation Monitoring Data Summary, and include personal and area monitoring data. Most of these data do not pertain to the relevant ONUs for the following reasons: (1) the worker activities associated with the personal monitoring data are not relevant to ONUs, and (2) the area monitoring data and the data for which the type of sampling is not reported are either not relevant to the exposure scenarios or are not relevant to ONUs. For example, in the case of the data pertaining to the Compounding of Polystyrene Resin to Produce XPS Masterbatch Containing HBCD, which is 8-hr TWA area monitoring data, the sampling location is the feed deck near typical operator positions. This data likely does not represent ONU exposure because an ONU is unlikely to be present at the feed deck for an entire shift.

EPA assumes HBCD air concentrations that ONUs are potentially exposed to are lower than HBCD air concentrations that workers are potentially exposed to because the dust is diluted as it is transported through workspaces by indoor or ambient air currents. EPA also assumes the duration and frequency of the ONUs' potential HBCD inhalation exposures to be lower than that of workers. The lower HBCD potential inhalation exposure levels of ONUs would result in lower risk for ONUs as compared to workers. Uncertainties related to EPA's assumptions related to ONU exposure levels are discussed in Section 2.4.1.15.4.

General Dermal Exposures Approach and Methodology

EPA estimated high-end worker dermal potential dose rate in accordance with the *EPA/OPPT Direct 2-Hand Dermal Contact with Solids Model* ([U.S. EPA 2013a](#)) in the case of the following exposure scenarios: the repackaging of import containers, compounding of polystyrene to produce XPS masterbatch, manufacturing of XPS foam using XPS masterbatch, manufacturing of XPS foam using HBCD powder, and formulation of flux/solder pastes (these scenarios are discussed in Sections 2.4.1.2 through 2.4.1.5 and 2.4.1.12). This high-end potential dose rate is equal to 3,100 mg/day which is the quantity of solids retained on a worker's skin during an event that results in the worker's contact with

the solids; the frequency of such events is assumed to be once per day ([U.S. EPA 2013a](#)). The *EPA/OPPT Direct 2-Hand Dermal Contact with Solids Model* does not include a central tendency value of the potential dose rate although this model is based on data reported in Lansink (1996) and both the high-end and central tendency values of these data are given in Lansink (1996). The central tendency potential dose rate that is associated with the high-end potential dose rate of 3,100 mg/day is equal to 900 mg/day. The central tendency value of 900 mg is reported in [Lansink et al. 1996](#) as cited in [Marquart et al. 2006](#). This central tendency value pertains to the manual loading of mixers with dusty powder and is designated as the typical case exposure ([Marquart et al. 2006](#))¹⁵.

EPA estimated high-end worker dermal potential dose rate in accordance with the *EPA/OPPT Direct 2-Hand Dermal Contact with Container Surfaces (Solids) Model* ([U.S. EPA 2013a](#)) in the case of the use of solder/flux pastes (this scenario is discussed in Section 2.2.13). This high-end potential dose rate is equal to 1,110 mg/day which is the quantity of solids retained on a worker's skin during an event that results in the worker's contact with the solids; the frequency of such events is assumed to be once per day ([U.S. EPA 2013a](#)). The *EPA/OPPT Direct 2-Hand Dermal Contact with Container Surfaces (Solids) Model* does not include a central tendency value of the potential dose rate although this model is based on data reported in Lansink (1996) and both the high-end and central tendency values of these data are given in Lansink et al. The central tendency potential dose rate that is associated with the high-end potential dose rate of 1,110 mg/day is equal to 450 mg/day. The central tendency value of 450 mg is reported in Lansink (1996) as cited in [Marquart et al. 2006](#). This central tendency value pertains to the gathering of closed bags of powder and is designated as the typical case exposure ([Marquart et al. 2006](#))¹⁶.

The two models that EPA used as mentioned above assume a single contact event per day and that the amount of solid on the skin is not expected to be significantly reduced by wiping from the skin or increased from repeated contact with the chemical (*i.e.*, wiping excess solids from the skin does not remove a significant fraction of the small layer of chemical adhering to the skin and additional contacts with the chemical do not add a significant fraction to the layer). EPA calculated the potential dose for a worker with no dermal protection by multiplying the quantity of solids on the skin by the weight fraction of HBCD in the solids and the frequency of exposure events. EPA does not expect dermal exposure for the remaining exposure scenarios because HBCD is entrained in the EPS and XPS foam (those in Section 2.4.1.6 through 2.4.1.11).

In this Risk Evaluation, EPA provides comparison of the potential worker dermal dose rates calculated by EPA and those estimated in the EURAR ([ECHA 2008b](#)) and Australian Risk Assessment ([NICNAS 2012b](#)). The EURAR and NICNAS both estimate potential dermal exposures using the Estimation and Assessment of Substance Exposure (EASE) model. The EASE model was developed by the UK Health and Safety Executive with the Health and Safety Laboratory. It predicts expected dermal exposures for a wide range of substances and scenarios using situational information related to the chemical ([Tickner et](#)

¹⁵ The high-end value of 3,100 mg also pertains to manual loading of mixers with dusty powder. This value corresponds to the value of 3,000 mg reported in Marquart et al. ([Marquart et al. 2006](#)) as the reasonable worst case exposure pertaining to loading of mixers and obtained from Lansink et al. ([Lansink et al., 1996](#)). EPA did not directly cite Lansink et al. ([Lansink et al., 1996](#)) because, as stated in Marquart et al. ([Marquart et al. 2006](#)), this report has not been published in a scientific journal.

¹⁶ The high-end value of 1,110 mg also pertains to the gathering of closed bags of powder. This value corresponds to the value of 1,050 mg reported in Marquart et al. ([Marquart et al., 2006](#)) as the reasonable worst case exposure pertaining to the gathering of closed bags of powder and obtained from Lansink et al. ([Lansink et al., 1996](#)). EPA did not directly cite Lansink et al. ([Lansink et al., 1996](#)) because, as stated in Marquart et al. ([Marquart et al., 2006](#)), this report has not been published in a scientific journal.

[al. 2005](#)).

For occupational exposures, EPA used the potential dermal dose rate estimated as described above to calculate exposure concentration metrics required for risk assessment. Specifically, EPA used the potential dermal dose rates and dermal absorption factor of 6.5% (discussed later in Section 3.2.2) to estimate the AAD and CAD. The AAD calculation entails the multiplication of the dermal potential dose rate by the dermal absorption factor, which is then divided by body weight. The CAD calculation is the same, with the additional multiplication of exposure frequency and working years, followed by division of the averaging time. The values used for body weight, exposure frequency, working years, and averaging time are explained in Appendix E.3. The AAD is used to assess acute exposure risks. The CAD is used to assess risks from chronic exposures.

Occupational non-users are workers who do not handle HBCD and thus, unlike workers, are not potentially exposed to HBCD dermally as a result of handling HBCD. However, ONUs are potentially exposed to HBCD dermally through contact with surfaces where HBCD dust has settled. EPA mentions this type of potential ONU dermal exposure in the discussions of the relevant occupational exposure scenarios, but EPA did not quantify these exposures due to lack of data, and EPA expects that dermal exposures may be much less likely for this population. Potential ONU dermal exposure to settled dust is unlikely in the case of the exposure scenarios that do not include worker dermal exposure because these exposure scenarios pertain to material (EPS resin beads and XPS/EPS insulation) in which the HBCD is entrained at low concentrations and worker or ONU contact with this material is unlikely to result in dermal exposure.

A summary of approaches and EPA's overall confidence in the exposure estimates are provided in Table 2-71.

Table 2-71. A Summary for Each of the 12 Occupational Exposure Scenarios (OESs)

[For many cases EPA was not able to estimate inhalation exposure for ONUs, but EPA expects these to be lower than inhalation exposure for workers; dermal exposure not estimated for ONUs since they are not expected to be in direct contact with HBCD.]

Occupational Exposure Scenario (OES)	Inhalation Exposure							Dermal Exposure Modeling ^c		
	Monitoring					Modeling		Overall Confidence	Worker	ONU
	Monitoring Data	# Data Points	Data Quality Rating	Worker	ONU	Worker	ONU			
Repackaging of Import Containers	✓	10	H	✓	✗	✗	✗	M	✓	-
Compounding of Polystyrene Resin to Produce XPS Masterbatch	✓	16	H	✓	✗	✗	✗	M	✓	-
Processing of HBCD to Produce XPS Foam using XPS Masterbatch	✓	9	H	✓	✗	✗	✗	M	✓	-
Processing of HBCD to Produce XPS Foam using HBCD Powder	✓	16	H	✓	✗	✗	✗	M	✓	-
Processing of HBCD to Produce EPS Foam Using Imported EPS Resin Beads ^a	✓	9	H	✓	✗	✗	✗	L to M	-	-
Processing of HBCD to Produce SIPs and Automobile Replacement Parts from XPS/EPS Foam ^a	✓	9	H	✓	✗	✗	✗	L to M	-	-
Installation of Automobile Replacement Parts ^b	✗	N/A	N/A	✗	✗	-	-	N/A	-	-
Installation of XPS/EPS Foam Insulation in Residential, Public and Commercial Buildings, and Other Structures ^a	✓	9	H	✓	✗	✗	✗	L to M	-	-
Demolition and Disposal of XPS/EPS Foam Insulation Products in Residential, Public and Commercial Buildings, and Other Structures ^a	✗	N/A	N/A	✗	✗	✓	✗	L to M	-	-
Recycling of EPS Foam and Reuse of XPS foam ^a	✓	9	H	✓	✗	✗	✗	L to M	-	-
Formulation of Flux/Solder Pastes	✓	16	H	✓	✗	✗	✗	M	✓	-
Use of Flux/Solder Pastes	✗	N/A	N/A	✗	✗	-	-	N/A	✓	-
Recycling of Electronics Waste (E-Waste) Containing HIPS	✓	24	H	✓	✗	✗	✗	M	✓	-

^a EPA does not expect dermal exposure of workers to be a part of these exposure scenarios.

^b The installation of automobile replacement parts is not expected to result in worker and ONU inhalation and dermal exposures.

^c The exposure scenarios preclude ONU dermal exposure because ONUs are not expected to handle HBCD.

Consideration of Engineering Controls and Personal Protective Equipment

OSHA requires and NIOSH recommends that employers utilize the hierarchy of controls to address hazardous exposures in the workplace. The hierarchy of controls strategy outlines, in descending order of priority, the use of elimination, substitution, engineering controls, administrative controls, and lastly personal protective equipment (PPE). The hierarchy of controls prioritizes the most effective measures first which is to eliminate or substitute the harmful chemical (*e.g.*, use a different process, substitute with a less hazardous material), thereby preventing or reducing exposure potential. Following elimination and substitution, the hierarchy recommends engineering controls to isolate employees from the hazard, followed by administrative controls, or changes in work practices to reduce exposure potential (*e.g.*, source enclosure, local exhaust ventilation systems). Administrative controls are policies and procedures instituted and overseen by the employer to reduce the potential for worker exposure to hazards, these could include training employees on the hazards and how to avoid them, policies regarding scheduling to reduce acute exposures, and housekeeping standards. As the last means of control, the use of personal protective equipment (*e.g.*, respirators, gloves) is recommended, when the other control measures cannot reduce workplace exposure to an acceptable level. The National Institute for Occupational Safety and Health (NIOSH) and the U.S. Department of Labor's Bureau of Labor Statistics (BLS) conducted a voluntary survey of U.S. employers regarding the use of respiratory protective devices between August 2001 and January 2002 ([NIOSH 2003](#)). For additional information, please also refer to *Memorandum_NIOSH_BLS Respirator Usage in Private Sector Firms, Docket # EPA-HQ-OPPT-2019-0500* ([U.S. EPA 2020](#)).

Respiratory Protection

OSHA's Respiratory Protection Standard (29 CFR Section 1910.134) requires employers in certain industries to address workplace hazards by implementing engineering control measures and, if these are not feasible, provide respirators that are applicable and suitable for the purpose intended. Respirator selection provisions are provided in Section 1910.134(d) and require that appropriate respirators are selected based on the respiratory hazard(s) to which the worker will be exposed and workplace and user factors that affect respirator performance and reliability. Assigned protection factors (APFs) are provided in Table 1 under Section 1910.134(d)(3)(i)(A) (see below in Table 2-72) and refer to the level of respiratory protection that a respirator or class of respirators is expected to provide to employees when the employer implements a continuing, effective respiratory protection program.

There are no OSHA or NIOSH exposure limits for the HBCD cluster: (CAS #: 25637-99-4; 3194-55-6; 3194-57-8), however, HBCD is handled in a powdered form with mean particle size ranges from 20 to 150 μm . There is the potential for generation of airborne HBCD dust during different worker activities. Employers should first consider elimination, substitution, engineering, and administrative controls to reduce exposure potential and, if exposures still present workplace, employers are required to institute a respiratory protection program and provide employees with NIOSH-certified respirators. Where other hazardous agents could exist in addition to HBCD, consideration of combination cartridges would be necessary. Table 2-72 can be used as a guide to show the protectiveness of each category of respirator; EPA took this information into consideration as discussed in Section 4.2.2. Based on the APF, inhalation exposures may be reduced by a factor of 5 to 10,000, when workers and occupational non-users are using respiratory protection.

Table 2-72. Assigned Protection Factors for Respirators in OSHA Standard 29 CFR Section 1910.134

Type of Respirator	Quarter Mask	Half Mask	Full Facepiece	Helmet/Hood	Loose-fitting Facepiece
1. Air-Purifying Respirator	5	10	50	-	-
2. Power Air-Purifying Respirator (PAPR)	-	50	1,000	25/1,000	25
3. Supplied-Air Respirator (SAR) or Airline Respirator					
• Demand mode	-	10	50	-	-
• Continuous flow mode	-	50	1,000	25/1,000	25
• Pressure-demand or other positive-pressure mode	-	50	1,000	-	-
4. Self-Contained Breathing Apparatus (SCBA)					
• Demand mode	-	10	50	50	-
• Pressure-demand or other positive-pressure mode (<i>e.g.</i> , open/closed circuit)	-	-	10,000	10,000	-
Source: 1910.134(d)(3)(i)(A)					

Dermal Protection

The Hand Protection section of OSHA's Personal Protective Equipment Standard (29 CFR Section 1910.138) requires employers to select and require workers to wear gloves to prevent exposure to harmful substances. As with respirators, gloves are used to prevent employee exposures to hazards. Employers base selection of gloves on the type of hazard encountered, conditions during use, tasks performed and factors that affect performance and wear ability. Gloves, if proven impervious to the hazardous chemical, and if worn on clean hands and replaced when contaminated or compromised, are expected to provide employees with protection from hazardous substances. HBCD is a solid particulate and would not be expected to permeate through gloves. Some examples of impervious gloves are nitrile, butyl rubber, polyvinyl chloride, and polychloroprene.

EPA reviewed safety data sheets (SDSs) for HBCD powder, EPS resin beads containing HBCD, and XPS and EPS foam containing HBCD. EPA did not find any SDSs for XPS masterbatch containing HBCD.

The exposure scenarios in this Risk Evaluation in which workers may handle HBCD powder include Repackaging of Import Containers, Compounding of Polystyrene Resin to Produce XPS Masterbatch, Processing of HBCD to Produce XPS Foam, and Formulation of Flux/Solder Pastes. For HBCD powder, an SDS from Great Lakes Chemical Corporation ([Great Lakes Chemical 2003](#)) recommended the use of neoprene gloves and an SDS from Santa Cruz Biotechnology Company, Inc. ([Santa Cruz Biotechnology 2009](#)) recommended the use of gloves made of polychloroprene, nitrile rubber, butyl rubber, Viton, or polyvinyl chloride.

The exposure scenarios in this Risk Evaluation in which workers may handle XPS or EPS foam containing HBCD include: Processing to Produce XPS Foam using XPS Masterbatch, Processing of HBCD to Produce XPS Foam, Processing to Produce EPS Foam from Imported EPS Resin Beads, Processing to Produce SIPs and Automobile Replacement Parts from XPS/EPS Foam, Installation of XPS/EPS Foam Insulation in Residential, Public and Commercial Buildings, and Other Structures, Demolition and Disposal of XPS/EPS Foam Insulation in Residential, Public and Commercial Buildings, and Other Structures, and Recycling of EPS Foam. EPA reviewed seven SDSs for XPS and EPS foam products containing HBCD. All the reviewed SDSs recommend suitable or appropriate gloves and, in some cases, gloves to protect from mechanical injury. The SDSs do not recommend specific glove materials ([Dow Chemical Pacific 2018](#); [DiversiFoam 2015](#); [Insulfoam a Division of Carlisle Construction 2015](#); [Multi-Panels 2015](#); [O. D. E. 2013](#); [Airlite Plastics Co dba Fox 2008](#); [A.C.H. Foam Technologies 2007](#)).

During Processing to Produce EPS Foam from Imported EPS Resin Beads, workers may handle EPS resin beads containing HBCD. An SDS from BASF recommends the use of non-static gloves, such as leather gloves, when handling EPS resin beads containing HBCD ([BASF 2015](#)). As indicated in Section 1.2.2, BASF has ceased the use of HBCD. EPA did not find additional glove material recommendations.

During Use of Flux/Solder Pastes, workers may handle flux/ solder paste formulations containing HBCD. SDSs from Henkel and Kester recommend the use of nitrile rubber gloves ([Henkel 2016](#); [Kester 2015](#)). The SDS from Kester also recommends the use of natural rubber gloves.

2.4.1.2 Repackaging of Import Containers

Imported HBCD is repackaged by unloading HBCD powder or granules from imported containers into an intermediate storage vessel or directly into new containers. Workers and ONUs are potentially exposed by inhalation to the HBCD dust that is generated during the transfer of HBCD. Also, there is a potential for ONU dermal exposure through contact with surfaces where HBCD dust has settled. Because of the larger particle size of the granules, inhalation exposure to dust during unloading of granules is expected to be lower than that from unloading powders ([NICNAS 2012b](#); [ECHA 2008b](#)).

Worker inhalation and dermal exposure during the unloading of imported EPS resin beads is not expected due to the larger size of the beads and because HBCD is entrained within the polymeric matrix of the EPS resin beads ([NICNAS 2012b](#); [ECHA 2008b](#)).

Number of Potentially Exposed Workers and Occupational Non-Users

As discussed in Section 2.2.1, EPA developed release and exposure estimates for repackaging of import containers at a single site. Of the five submitters to 2016 CDR, four submitters estimate that fewer than 10 workers are potentially exposed to HBCD, while the fifth submitter estimated that at least 10 but fewer than 25 workers are potentially exposed to HBCD. However, the companies that previously reported HBCD import volumes to 2016 CDR have stated to EPA that they permanently stopped the activity in 2016 or 2017. Thus, in lieu of using this CDR data from companies that discontinued use of HBCD, EPA estimated the number of workers potentially exposed using Bureau of Labor Statistics (BLS) data.

Based on BLS data for NAICS code 493100, Warehousing and Storage, and related Standard Occupational Classification (SOC) codes, there are on average an estimated three workers and one ONU per site at warehousing and storage facilities. Based on these BLS data and one site for the repackaging of import containers, EPA estimated that a total of three workers and one ONU are potentially exposed during this exposure scenario.

Inhalation Exposure Assessment

EPA estimated HBCD potential inhalation exposure concentrations to be equal to surrogate HBCD occupational inhalation exposure concentration monitoring data. These surrogate data are worker monitoring data that pertain to various worker activities during the manufacturing of HBCD in Europe. EPA also considered other HBCD occupational inhalation exposure concentration data as surrogate monitoring but chose the data mentioned above as further discussed below.

HBCD occupational inhalation exposure monitoring data that EPA considered are shown in Table 2-73 below. EPA selected the data of Searl and Robertson (2005), which are noted as 1a in this table, as the surrogate monitoring data from among all of the data in Table 2-73 because (a) the overall quality confidence rating in these data is high as determined via EPA's systematic review, (b) the worker activities that these data pertain to include packaging and working in a warehouse, (c) these data pertain to standard grade HBCD, and (d) these data are 8-hr TWA personal breathing zone measurements. EPA estimated central tendency and high-end exposure concentrations to be equal to the median value of 0.89 mg/m³ and the 90th percentile value of 1.89 mg/m³ of the surrogate monitoring data, respectively.

EPA also considered worker monitoring data other than the data mentioned above as surrogate data. Specifically, EPA considered data that pertain to worker activities that include addition of HBCD to process equipment provided in Table 2-74.. These data are from Thomsen (2007), which are noted as 1a and 1b in this table, and the data from Searl and Robertson (2005), which are noted as 2a-d in this table. EPA did not select these data as surrogate data because the addition of HBCD to process equipment is likely to involve handling of smaller quantities of HBCD as compared to the repackaging of HBCD.

The exposure frequency for this exposure scenario is a range of 29 to 250 days/year. As discussed in Section 2.2.2, EPA estimated days of release at a repackaging site as a range from 29 to 300 days/year. EPA expects this range of release days is also reflective of the operating days during which HBCD is repackaged at an importation site and workers are potentially exposed to HBCD. However, EPA does not expect that workers will be exposed greater than 250 day/year, accounting for a worker schedule of five days per week and 50 weeks per year. EPA used the midpoint of this range of exposure frequency, rounded up where the midpoint resulted in fractions of days, to calculate central tendency average daily dose. EPA used the high-end of this range of exposure frequency to calculate high-end average daily dose. Additionally, EPA estimated worker exposure over the full working day, or eight hours/day, as the data used to estimate inhalation exposures are 8-hour time-weighted average (TWA) data.

Table 2-73. Inhalation Monitoring Data for Manufacturing of HBCD

Data Source/Study ^a	Exposure Scenario	Form of HBCD Handled	Type of Sample	Worker Activity or Sampling Location	Exposure Concentration (mg/m ³) ^b	Number of Samples	Sample Time / Type of Measurement	Source ^c	Overall Confidence Rating
Inhalation Monitoring Data Used to Estimate Worker Exposures Resulting from Repackaging									
Searl and Robertson (2005) – 1a	Manufacturing of HBCD	Standard grade HBCD	Personal Breathing Zone	Packaging, compaction, process operations, and working in the warehouse	Mean: 1.23 Median: 0.89 90th percentile: 1.89 Max: 3 mg/m ³	10	8-hr TWA	(ECHA 2008b) (ECHA 2009b)	High
Other Inhalation Monitoring Data Pertaining to the Manufacturing of HBCD that EPA Considered as Surrogate Monitoring Data									
Searl and Robertson (2005) - 1b	Manufacturing of HBCD	Fine grade HBCD	Personal Breathing Zone	Packaging, compaction, process operations, and working in the warehouse	Mean: 23 90th percentile: 35	4	8-hr TWA	(ECHA 2008b)	High
Searl and Robertson (2005) – 1c	Manufacturing of HBCD	HBCD of unknown grade	NR	Packaging and compaction of powders	Respirable, mean: 0.18 Inhalable, Mean: 1.23	NR	NR	(ECHA 2009c)	High
Waindzioch (2000) - 1a	Manufacturing of HBCD	HBCD of unknown grade	Area	Reactor	0.00028 - 0.0285	3	Short-term	(ECHA 2008b)	Unacceptable
Waindzioch (2000) - 1b	Manufacturing of HBCD	HBCD of unknown grade	Area	Filling Station	0.0094 - 0.097	2	Short-term	(ECHA 2008b)	High
Biesemeier (1996)	Manufacturing of HBCD	HBCD of unknown grade	NR	Bagging HBCD product	4.0 - 4.5	NR	NR	(ECHA 2008b)	High
Velsicol (1978)	Manufacturing of HBCD	HBCD of unknown grade	Personal Breathing Zone	Transfer of the HBCD in the hammer-mill to 28 drums	1.9	1	300 minutes	(Velsicol Chem Corp 1978)	High
Yi et al. (2016)	Manufacturing of HBCD	HBCD of unknown grade	Personal Breathing Zone	NR	0.0102 - 0.0283	14	NR	(Yi et al. 2016)	High

Data Source/Study ^a	Exposure Scenario	Form of HBCD Handled	Type of Sample	Worker Activity or Sampling Location	Exposure Concentration (mg/m³) ^b	Number of Samples	Sample Time / Type of Measurement	Source ^c	Overall Confidence Rating
<p>NR = Not Reported; N/A = Not Applicable</p> <p>a – Where multiple datasets were available from one literature source, EPA distinguished data as 1a, 1b, 2a, 2b, etc.</p> <p>b – The statistical values were obtained from the referenced literature source and were not calculated by EPA.</p> <p>c – The source where the respective data was extracted. All sources of the information are mentioned. In the case of multiple sources, information from the various sources is presented as contained in these sources and EPA did not combine the information from the various sources.</p>									

Dermal Exposure Assessment

As described in Section 2.4.1.1. and assuming two-hand contact to solids containing 100% HBCD, EPA calculated the potential dose for a worker to be 3,100 mg HBCD/day (high-end) and 900 mg HBCD/day (central tendency) ([U.S. EPA 2013a](#)).

The EURAR estimated dermal exposure during manufacturing of HBCD (importation and repackaging was not included in the EURAR) using EASE model. The EURAR estimated an exposure to standard grade HBCD powder of 1 mg/cm²-day. This translates into a dose of 1,070 mg/day, using EPA's two-hand surface area of 1,070 cm². The NICNAS report estimated dermal exposure during importation and repackaging to standard grade HBCD powder of 0.1 to 1 mg/cm²-day using the EASE model. Using EPA's two-hand surface area, this results in a dose of 107 to 1,070 mg/day.

Strengths, Limitations, and Confidence in Assessment Results

EPA has medium confidence in the assessed potential inhalation exposure concentrations presented above. EPA considered the quality of the data, the assessment approach, and uncertainties in assessment results to determine the level of confidence.

The result of EPA's systematic review is inhalation exposure monitoring data with an overall confidence rating of high which is a strength of the assessment. The strength of the assessment approach is the estimation of inhalation exposure concentrations based on inhalation exposure concentration monitoring data that (a) are the preferred type of monitoring data (*i.e.*, 8-hr TWA personal breathing zone data), and (b) are surrogate data pertaining to various worker activities that include an activity that is relevant to the assessed exposure scenario.

There is uncertainty about the extent to which the surrogate inhalation exposure concentration monitoring data are valid surrogate data because of the following reasons. First, these concentrations are based on worker monitoring data that pertain to various worker activities including activities that are not relevant to the exposure scenario. Second, EPA is uncertain that the packaging process associated with the worker monitoring data and the repackaging process in the U.S. are equivalent in terms of worker exposure. There is also uncertainty in the estimated HBCD potential inhalation exposure concentrations because these concentrations pertain to workers in Europe and the extent to which these concentrations represent the distribution of inhalation exposure air concentrations pertaining to workers in the U.S. is uncertain. Refer to Section 2.4.1.14 for additional discussion of uncertainty. Based on these strengths, and uncertainties, EPA has medium confidence in the assessed occupational inhalation exposure air concentrations.

2.4.1.3 Compounding of Polystyrene Resin to Produce XPS Masterbatch

Workers are expected to manually unload and transfer HBCD powder or granules into hoppers or other equipment used to feed the HBCD into XPS masterbatch mixing equipment. This manual transfer may result in worker inhalation exposure to HBCD dust and dermal exposure to solid HBCD. Additionally, the generated dust from these transfer activities may result in ONU inhalation exposure to the HBCD dust and ONU dermal exposure through contact with surfaces where HBCD dust has settled.

Workers may also be potentially exposed from occasional cleaning of process equipment and loading of XPS masterbatch into packages, if these activities are manual.

Number of Potentially Exposed Workers and Occupational Non-Users

As discussed in Section 2.2.3, EPA developed exposure estimates for one site for this exposure scenario. The two submissions in 2016 CDR that identify the industrial sector as "plastic material and resin

manufacturing” each estimate that at least 50 but fewer than 100 workers are potentially exposed to HBCD. However, the companies that previously reported HBCD import volumes to CDR have stated to EPA that they permanently stopped the activity in 2016 or 2017. Thus, in lieu of using this CDR data from companies that discontinued use of HBCD, EPA estimated the number of workers potentially exposed using Bureau of Labor Statistics (BLS) data.

Based on data from the Bureau of Labor Statistics (BLS) for NAICS code 325991, Custom Compounding of Purchased Resins, and related Standard Occupational Classification (SOC) codes, there are on average an estimated 20 workers and 7 ONUs per site at custom compounding facilities. Based on these data and one modeled site for the production of XPS masterbatch, EPA estimated that a total of 20 workers and 7 ONUs are potentially exposed during this exposure scenario.

Occupational Exposure Assessment

Inhalation Exposure Assessment

EPA estimated HBCD potential inhalation exposure concentrations to be equal to the assessed exposure concentrations reported in the EURAR ([ECHA 2008b](#)) that pertain to all polymer processing operations involving standard grade HBCD. These assessed exposure concentrations of the EURAR are based on HBCD occupational inhalation exposure concentrations that pertain to the manufacture of EPS resin beads. EPA considered HBCD occupational inhalation exposure concentration data that pertain to the exposure scenario that is the subject of this section as well as data that pertain to other exposure scenarios but chose the assessment approach mentioned above.

EPA found monitoring data that pertain to the exposure scenario that is the subject of this section and the overall confidence rating of these data is high as determined via EPA’s systematic review. These data are the data of Searl and Robertson ([2005](#)), which are HBCD occupational inhalation exposure concentration monitoring data pertaining to the compounding of polystyrene resin and production of XPS masterbatch at sites in Europe and are presented in Table 2-74. and noted in this table as 3a-d. EPA did not incorporate these data into the estimate of exposure concentrations because the grade of HBCD associated with these data is not reported and the type of sample (personal breathing zone or area) is reported for only half of these data.

Table 2-74. Summary of Inhalation Monitoring Data for Handling of HBCD

Literature Study ^a	Exposure Scenario	Form of HBCD Handled	Type of Sample	Worker Activity or Sampling Location	Exposure Concentration (mg/m ³) ^b	Number of Samples	Sample Time / Type of Measurement	Source ^c	Overall Confidence Rating
Inhalation Monitoring Data Used to Estimate Worker Exposures (both in this Risk Evaluation and the EURAR)									
Searl and Robertson (2005) - 2a	Manufacturing of EPS Resin beads	Standard grade HBCD	Personal	Manual addition of HBCD powder to reactor each time a batch of EPS resin was produced	Range: 2.89-21.5 Mean: 7.2 Median: 5.52 90th percentile: 10.5	12	Short-term (13 to 56 mins)	(NICNAS 2012b); (ECHA 2008b)	High
Searl and Robertson (2005) - 2b	Manufacturing of EPS Resin beads	Standard grade HBCD	Personal	Manual addition of HBCD powder to reactor each time a batch of EPS resin was produced	Range: 0.12-3.36 Mean: 1 Median: 0.42 90th percentile: 1.11 (NICNAS 2012b); 1.3 (ECHA 2008b)	12	8-hr TWA – note these are 8-hr TWA values of the data in the above row	(NICNAS 2012b); (ECHA 2008b)	High
Searl and Robertson (2005) - 2c	Manufacturing of EPS Resin beads	Standard grade HBCD	Personal	Manual addition of HBCD powder to reactor each time a batch of EPS resin was produced	Range: 0.07-14.7 Mean: 1.2 Median: 0.27 90th percentile: 1.10	18	8-hr TWA (ECHA 2008b); Full-Shift (NICNAS 2012b)	(NICNAS 2012b); (ECHA 2008b)	High
Searl and Robertson (2005) - 2d	Manufacturing of EPS Resin beads	Standard grade HBCD	Personal	Weighing powder prior to addition to reactor. HBCD bags were weighed and opened concurrently, or weighed in advance, in which case HBCD was transferred from 25-kg sacks using plastic scoop (full-shift measurement).	Range: 4.35-12.1 Mean: 7.2 Median: 6.19 90th percentile: 10.5 (NICNAS 2012b); 10.6 (ECHA 2008b);	4	8-hr TWA (ECHA 2008b); Full Shift (NICNAS 2012b)	(NICNAS 2012b); (ECHA 2008b)	High
Other Inhalation Monitoring Data for Handling of HBCD									
Searl and Robertson (2005) - 3a	Compounding of Polystyrene resin to produce XPS Masterbatch containing HBCD	HBCD of unknown grade	Area	Weighing and mixing	Max 7.5 (for 2 hours) Mean: 1.89 Median: 0.83 90th percentile: 5.4	10	Short-term	(ECHA 2008b); (ECHA 2009b)	High
Searl and Robertson (2005) - 3b	Compounding of Polystyrene resin to produce XPS	HBCD of unknown grade	Area	Weighing and mixing	Mean: 0.88 90th percentile: 1.36	10	8-hr TWA	(ECHA 2008b)	High

Literature Study ^a	Exposure Scenario	Form of HBCD Handled	Type of Sample	Worker Activity or Sampling Location	Exposure Concentration (mg/m ³) ^b	Number of Samples	Sample Time / Type of Measurement	Source ^c	Overall Confidence Rating
	Masterbatch containing HBCD								
Searl and Robertson (2005) - 3c	Compounding of Polystyrene resin to produce XPS Masterbatch containing HBCD	HBCD of unknown grade	NR	Extruder	Mean: 0.12 Median: 0.10 90th percentile: 0.16	4	5 hours	(ECHA 2008b) (ECHA 2009b)	High
Searl and Robertson (2005) - 3d	Compounding of Polystyrene resin to produce XPS Masterbatch containing HBCD	HBCD of unknown grade	NR	Automated handling of HBCD	Negligible	3	NR	(ECHA 2008b)	High
Abbott (2001) - 1a	Manufacture of XPS from HBCD powder or granules	Standard grade HBCD	Area	At the feed deck near typical operator positions	Range 0.24 – 1.6 Mean: 0.66 90th percentile: 1.45 (excluding 10 ND samples)	16 (10 ND)	8-hr TWA	(ECHA 2008b)	High
Abbott (2001) - 1b	Manufacture of XPS from HBCD powder or granules	HBCD powder and granules	Personal breathing zone	Activities in the mixer area, including operating a closed automated process excluding potential contact with neat HBCD	Range: 0.0002-0.0009 Mean: 0.0005 Median: 0.0005	6	8-hr TWA	(ECHA 2008b) (NICNAS 2012b)	High
Thomsen (2007) - 1a	Manufacture of XPS from HBCD powder or granules	HBCD powder and granules	Personal breathing zone	Weighing and addition of HBCD to the reactor and subsequent washing, centrifugation, sifting, and transfer of product to a silo container	Range: 0.001-0.15 Mean: 0.015 Median: 0.0027	24	8-hr TWA	Thomsen (2007)	High
Thomsen (2007) - 1b	Manufacture of XPS from HBCD powder or granules	HBCD granules	Mostly area and some personal breathing zone	Feed deck near typical operator positions	Range 0.005-0.9 Mean: 0.24 90th percentile: 0.47 (excluding 16 ND samples)	43 (16 ND)	60 – 1435 minutes	(ECHA 2008b)	High

Literature Study ^a	Exposure Scenario	Form of HBCD Handled	Type of Sample	Worker Activity or Sampling Location	Exposure Concentration (mg/m ³) ^b	Number of Samples	Sample Time / Type of Measurement	Source ^c	Overall Confidence Rating
Searl and Robertson (2005) - 4	Manufacture of XPS from HBCD powder or granules	HBCD granules	Area	Logistics, extruding, and laboratory	Mean: 0.00003 90th percentile: 0.00004	12	8-hr TWA	(ECHA 2008b)	High
Ransbotyn (1999)	Manufacturing of EPS Resin beads	Respirable Dust Inhalable Dust	Personal	Addition of HBCDD to reactor or the supervising of the addition.	Respirable dust: <0.5 Total Inhalable dust: 2.0 Not specific to HBCD	5	Max 8-hr TWA	(ECHA 2008b)	High
NICNAS (2012b) - 1a	All industrial polymer processing sites ^d	Standard grade HBCD	Modelled with EASE	Addition of HBCD into process operation	Typical: 2 to 5 "Worst-case": 5 to 50	N/A - this is a modelled exposure	8-hr TWA	(NICNAS 2012b)	High
NICNAS (2012b) - 1b	HBCD importation / repackaging sites and all industrial polymer processing sites ^d	HBCD granules	Modelled with EASE	Repackaging with the use of LEV (typical) and without LEV (worst-case)	Typical: 0.2 to 0.5 "Worst-case": 0.5 to 5	N/A - this is a modelled exposure	8-hr TWA	(NICNAS 2012b)	High

NR = Not Reported; N/A = Not Applicable

a – Where multiple datasets were available from one literature source, EPA distinguished data as 1a, 1b, 2a, 2b, etc.

b - The statistical values were obtained from the referenced literature source and were not calculated by EPA.

c – All sources of the information are mentioned. In the case of multiple sources, information from the various sources is presented as contained in these sources and EPA did not combine the information from the various sources.

d - Per NICNAS (2012b), this includes EPA's exposure scenarios for Compounding of Polystyrene Resin to Product XPS Masterbatch, Processing HBCD to Produce XPS Foam using XPS Masterbatch, Processing of HBCD to Produce XPS Foam using HBCD Powder, and Processing of HBCD to Produce EPS Foam from Imported EPS Resin Beads.

The HBCD occupational inhalation exposure concentration data or modeling results from Thomsen (2007), NICNAS (2012b), Abbott (2001) and Ransbotyn (1999), which are given in Table 2-74., pertain to various processes other than the compounding of polystyrene resin and production of XPS masterbatch. The overall confidence rating of all of these data is high as determined via EPA's systematic review; however, EPA did not further consider these data as surrogate data because none of these data are 8-hr TWA personal breathing zone data that are only associated with HBCD standard grade powder.

The HBCD occupational inhalation exposure concentration data of Searl and Robertson (2005) that pertain to the manufacture of EPS resin beads (provided in Table 2-74. and noted in this table as 2b-d) are 8-hr TWA personal breathing zone data that are only associated with HBCD standard grade powder. The overall confidence rating of all these data is high as determined via EPA's systematic review process. EPA determined these data are surrogate data because these data pertain to the worker activity of HBCD manual addition to process equipment which is the worker activity that is expected to result in the largest exposure in the case of the exposure scenario that is the topic of this section. However, EPA cannot incorporate all this surrogate data into estimates of exposure concentrations because the discrete data points of the various datasets are not available, and EPA cannot calculate the 50th percentile and 95th percentile values of all the data to assess central tendency and high-end values. However, as detailed in Appendix E.2, all of these data are the basis of the assessed "typical" and "reasonable worst-case" HBCD occupational exposure concentrations that are reported in the EURAR and that pertain to all polymer processing operations involving standard grade HBCD. Hence, EPA estimated HBCD occupational exposure concentrations to be equal to these assessed exposure concentrations of the EURAR. Specifically, EPA estimated high-end and central tendency exposure concentrations to be equal to, respectively, the "reasonable worst-case" exposure concentration of 2.5 mg/m³ and the "typical" exposure concentration that is equal to one half of the reasonable worst-case, or 1.25 mg/m³.

As discussed in Section 2.2.3, EPA estimated a range of release days of 10 to 60 days/year. EPA expects this range of release days is also reflective of the operating days during which HBCD is processed at a compounding site and workers are potentially exposed to HBCD. EPA used the midpoint of this range of exposure frequency (rounded up) to calculate central tendency average daily dose and used the high-end of this range of exposure frequency to calculate high-end average daily dose. Additionally, EPA estimated worker exposures over the full working day, or eight hours/day, as the data used to estimate inhalation exposures is 8-hour TWA data.

Dermal Exposure Assessment

As described in Section 2.4.1.1, EPA calculated dermal exposure assuming two-hand contact to solids containing 100% HBCD (NICNAS 2012b; KemI 2009) because sites that produce HBCD flame-retarded XPS masterbatch receive manufactured or imported HBCD in its pure form to be 3,100 mg HBCD/day (high-end) and 900 mg HBCD/day (central tendency).

The EURAR estimated dermal exposure for the use of HBCD standard grade powder as an additive in XPS masterbatch and XPS foam manufacturing. The EASE model estimated this exposure to be 0.1 mg/cm²-day two-hand surface area of 1,070 cm². Using EPA's two-hand surface area of 1,070 cm², this results in a dose of 107 to 1,070 mg/day.

Strengths, Limitations, and Confidence in Assessment Results

EPA has medium confidence in the assessed inhalation exposure concentrations presented above. EPA considered the quality of the data, the assessment approach, and uncertainties in assessment results to determine the level of confidence.

The result of EPA's systematic review is inhalation exposure monitoring data with an overall confidence rating of high which is a strength of the assessment. The strength of the assessment approach is the estimation of inhalation exposure concentrations based on inhalation exposure concentration monitoring data that (a) are the preferred type of monitoring data (*i.e.*, 8-hr TWA personal breathing zone data), (b) are surrogate data pertaining to a worker activity that is certainly relevant to the assessed exposure scenario, and (c) comprise multiple datasets.

The limitation of the assessment approach is the estimation of inhalation exposure concentrations based on worker monitoring data that pertain to the worker activity that is expected to result in the largest exposure but that do not pertain to other worker activities.

There is uncertainty in the estimated HBCD potential inhalation exposure concentrations because the bases of these concentrations are data that pertain to workers in Europe and the extent to which these concentrations represent the distribution of inhalation exposure air concentrations pertaining to workers in the U.S. is uncertain. Refer to Section 2.4.1.14 for additional discussion of uncertainty. Based on these strengths, limitation, and uncertainty, EPA has medium confidence in the assessed occupational inhalation exposure air concentrations.

2.4.1.4 Processing of HBCD to Produce XPS Foam using XPS Masterbatch

Workers may be exposed to HBCD while manually unloading and transferring XPS masterbatch directly into the extruder or into equipment used to feed the XPS masterbatch into the extruder. This manual transfer may result in worker inhalation exposure to HBCD dust that was generated from abrasion of the XPS masterbatch pellets or granules during transport ([OECD 2009](#)). Manual transfers may also result in worker dermal exposure to solid HBCD. Additionally, the generated dust from these transfer activities may result in ONU inhalation exposure to HBCD and ONU dermal exposure through contact with surfaces where HBCD dust has settled.

Workers may also be potentially exposed from occasional cleaning of process equipment and cutting of the foam (*i.e.*, secondary processing) into slabs or other shapes ([ECHA 2009b](#)).

Number of Potentially Exposed Workers and Occupational Non-Users

The 2016 CDR data identifies multiple submissions that claim industrial use in the "construction" and "plastics product manufacturing" sectors ([U.S. EPA 2016c](#)). These industrial sectors are broad and can include a variety of sites, including sites that do not produce or install XPS and EPS foam, thus the reported estimates of number of workers potentially exposed at these sites may not be applicable to this exposure scenario.

EPA used workers and ONU estimates determined from an analysis of BLS data for the NAICS code 326140, Polystyrene Foam Product Manufacturing. These data indicate that there are, on average, 20 workers and 6 ONUs per site within NAICS code 326140. Based on these data and one modeled site for the manufacturing of XPS foam from XPS masterbatch, EPA estimated that a total of 20 workers and 6 ONUs are potentially exposed in this exposure scenario.

Inhalation Exposure Assessment

EPA estimated HBCD potential inhalation exposure concentrations to be equal to HBCD occupational inhalation exposure concentration monitoring data pertaining to the exposure scenario discussed in this section. The EURAR ([ECHA 2008b](#)) includes HBCD occupational inhalation exposure monitoring data pertaining to the manufacturing of XPS Foam at multiple sites in Europe using XPS masterbatch and

these data are presented in Table 2-75. As detailed in this table, these data pertain to various worker activities or parts of the process for production of XPS foam from XPS masterbatch. These data were obtained by sampling dust and analyzing the samples for HBCD ([ECHA 2008b](#)). Workers are potentially exposed to HBCD contained in dust comprising airborne fragments of XPS foam ([ECHA 2009b](#)) or XPS masterbatch. Each of the data in Table 2-75 have an overall confidence rating of high as determined via EPA's systematic review but EPA selected only the data in this table that pertain to the Secondary Processing of XPS foam as the estimates of HBCD inhalation exposure concentrations because EPA cannot calculate the mean and 95th percentile of all of the data given in this table. EPA cannot calculate these statistical values because the individual data points of the various dataset of Table 2-75 are not reported in the EURAR.

Most of the samples associated with the Searl and Robertson ([2005](#)) datasets that are noted in the table as (5a) and (5b) contained HBCD at levels below the detection limit. Specifically, HBCD was detected in only three of the fourteen dust samples associated with the Searl and Robertson ([2005](#)) datasets noted in the table as 5a and 5b. Nine of these fourteen samples were taken during the secondary processing of XPS foam (the Searl and Robertson ([2005](#)) dataset (5a)), which EPA interprets to mean cutting, sawing, and machining of XPS foam to manufacture shaped products (discussed Section 2.4.1.6) and the other five samples were taken during XPS foam reclamation (the Searl and Robertson ([2005](#)) data set (5b)), which is the shredding and reprocessing of process waste ([ECHA 2009b](#)).

Although HBCD was not detected in most of the samples associated with the Secondary Processing of XPA foam, EPA selected the data that pertains to this part of the process because these data include larger values and a wider range of exposure concentrations as compared with the data that pertain to the other parts of the process or worker activities. In conclusion, EPA estimated worker exposure to HBCD during the production of XPS foam from masterbatch using the mean and high-end values of the data that pertain to the secondary processing of XPS foam: 0.08 mg/m³ as a central tendency estimate of exposure concentration and the 90th percentile value of 0.22 mg/m³ as the high-end estimate of exposure concentration.

As discussed in Section 2.2.4, EPA estimated a range of release days of 1 to 16 days/year for air releases. EPA expects this range of release days is reflective of the operating days during which HBCD is processed at a converting site and workers are potentially exposed to HBCD. EPA used the midpoint of the range of exposure frequency and rounded up when the midpoint resulted in fractions of days, to calculate central tendency average daily dose. EPA used the high-end of this range of exposure frequency to calculate high-end average daily dose. Additionally, EPA estimated worker exposure over the full working day, or eight hours/day, as the data used to estimate inhalation exposures is 8-hour TWA data.

Table 2-75. Summary of Inhalation Monitoring Data for the Manufacture of XPS Foam Using XPS Masterbatch Containing HBCD

Literature Study ^a	Exposure Scenario	Form of HBCD Handled	Type of Sample	Worker Activity or Sampling Location	Exposure Concentration (mg/m ³) ^b	Number of Samples	Sample Time / Type of Measurement	Source	Overall Confidence Rating
Inhalation Monitoring Data Used to Estimate Worker Exposure									
Searl and Robertson (2005) - 5a	Processing of HBCD to Produce XPS from XPS Masterbatch	HBCD in XPS foam	NR	Secondary processing of XPS foam	Mean: 0.08 90th percentile: 0.22 ^c	9	8-hr TWA	Original source: (Searl and Robertson 2005) Reported in: (ECHA 2009b , 2008b)	High
Other Inhalation Monitoring Data for Handling of XPS Foam									
Searl and Robertson (2005) - 5b	Processing of HBCD to Produce XPS from XPS Masterbatch	HBCD in XPS foam	NR	Reclamation of XPS foam - including shredding and reprocessing of process waste	Mean: 0.02 90th percentile: 0.02 ^c	5	8-hr TWA	Original source: (Searl and Robertson 2005) Reported in: (ECHA 2009b , 2008b)	High
Searl and Robertson (2005) - 5c	Processing of HBCD to Produce XPS from XPS Masterbatch	HBCD in XPS foam	NR	Other process control operators	Mean: 0.03 90th percentile: 0.03 ^c	4	8-hr TWA	Original source: (Searl and Robertson 2005) Reported in: (ECHA 2009b , 2008b)	High
Searl and Robertson (2005) - 5d	Processing of HBCD to Produce XPS from XPS Masterbatch	XPS Masterbatch	NR	Process operators handling XPS masterbatch	Mean: 0.03 90th percentile: 0.03 ^c	24	8-hr TWA	Original source: (Searl and Robertson 2005) Reported in: (ECHA 2009b , 2008b)	High

NR = Not Reported; N/A = Not Applicable

a – Where multiple datasets are reported in a single literature source, EPA distinguished the various datasets as 1a, 1b, 2a, 2b, etc.

b – The statistical values were obtained from the referenced literature source and were not calculated by EPA.

c – The EURAR defines the secondary processing of EPS foam as the cutting, sawing, and machining of EPS foam and therefore EPA assumed the term “secondary processing of XPS foam” to mean cutting, sawing and machining of XPS foam.

Dermal Exposure Assessment

As described in Section 2.4.1.1, EPA calculated dermal exposure assuming two-hand contact to solid XPS masterbatch containing 70% HBCD ([NICNAS 2012b](#); [ECHA 2008b](#)). EPA used this weight fraction because workers at sites that produce XPS foam from XPS masterbatch have the highest potential dermal exposure concentration to HBCD during the unloading of XPS masterbatch. Using this model and 70% HBCD, EPA calculated the potential dose for a worker to be 2,170 mg HBCD/day (high-end) and 630 mg HBCD/day (central tendency). The EURAR and NICNAS report do not estimate dermal exposures during this operation.

Strengths, Limitations, and Confidence in Assessment Results

EPA has medium confidence in the assessed inhalation exposure concentrations presented above. EPA considered the quality of the data, the assessment approach, and uncertainties in assessment results to determine the level of confidence.

The result of EPA's systematic review is inhalation exposure monitoring data with an overall confidence rating of high which is a strength of the assessment. The strength of the assessment approach is the estimation of inhalation exposure concentrations to be equal to worker monitoring data pertaining to the exposure scenario and the selection of a dataset of the worker monitoring data that includes the largest range of values as the basis of the estimated exposure concentrations.

The limitations of the assessment approach are the following: (a) the estimation of inhalation exposure concentrations to be equal to monitoring data pertaining to only a part of the process for the manufacture of XPS foam using XPS masterbatch and not all of this process and (b) the worker monitoring data that are the basis of the estimated inhalation exposure concentrations are not the preferred type because the type of sampling (personal breathing zone or area monitoring) is not reported for this data.

There is uncertainty in the estimated HBCD potential inhalation exposure concentrations because most of the worker monitoring data that are the basis of the estimated inhalation exposure concentrations are non-detects (specifically, 3 or fewer of the total of 9 samples are non-detects). Also, these concentrations pertain to workers in Europe and the extent to which these concentrations represent the distribution of inhalation exposure air concentrations pertaining to workers in the U.S. is uncertain. Refer to Section 2.4.1.14 for additional discussion of uncertainty. Based on these strengths, limitations, and uncertainty, EPA has medium confidence in the assessed occupational inhalation exposure air concentrations.

2.4.1.5 Processing of HBCD to Produce XPS Foam Using HBCD Powder

Workers are expected to manually unload and transfer HBCD powder directly into the extruder or into equipment used to feed the powder into the extruder. This manual transfer may result in worker inhalation exposure to HBCD dust and dermal exposure to solid HBCD. Additionally, the generated dust from these transfer activities may result in ONU inhalation exposure to the HBCD dust and ONU dermal exposure through contact with surfaces where HBCD dust has settled.

Workers may also be potentially exposed from occasional cleaning of process equipment and cutting of the foam into slabs or other shapes, if these activities are manual. However, the unloading of HBCD powder is expected to present the highest potential exposure to HBCD, as HBCD is at the highest concentration during this activity.

Number of Potentially Exposed Workers and Occupational Non-Users

The 2016 CDR data identifies multiple submissions that claim industrial use in the "construction" and "plastics product manufacturing" sectors (2016 CDR, [U.S. EPA 2016c](#)). These industrial sectors are

broad and can include a variety of sites, including sites that do not produce or install XPS and EPS foam, thus the reported estimates of number of workers potentially exposed at these sites may not be applicable to this exposure scenario.

EPA used workers and ONU estimates determined from an analysis of BLS data for the NAICS code 326140, Polystyrene Foam Product Manufacturing. These data indicate that there are, on average, 20 workers and 6 ONUs per site within NAICS code 326140. Based on this data and one modeled site for the manufacturing of XPS foam from HBCD powder, EPA estimated that a total of 20 workers and 6 ONUs are potentially exposed during this exposure scenario.

Inhalation Exposure Assessment

EPA estimated HBCD potential exposure concentrations to be equal to the assessed exposure concentrations reported in the EURAR ([ECHA 2008b](#)) that pertain to all polymer processing operations involving standard grade HBCD. These assessed exposure concentrations of the EURAR are based on HBCD occupational inhalation exposure concentrations that pertain to the manufacture of EPS resin beads. EPA considered HBCD occupational inhalation exposure concentration data that pertain to the exposure scenario that is the subject of this section but chose that the assessment approach mentioned above.

EPA identified other monitoring data pertaining to this exposure scenario with overall confidence ratings of high as determined via EPA's systematic review. These data are given in Table 2-74. in Section 2.4.1.3. Specifically, the data in this table referenced here are the data of Abbott ([2001](#)), Thomsen ([2007](#)) and the data of Searl and Robertson ([2005](#)) that are noted in this table as (4). EPA expects the handling of HBCD standard grade powder to result in the largest potential exposure concentrations, and therefore EPA did not incorporate these data into the estimate of potential exposure concentrations because these data are not 8-hr TWA personal breathing zone data that are only associated with HBCD standard grade powder.

EPA expects the worker activity of manual addition of HBCD to process equipment to result in the largest potential exposure concentration. Therefore, as in the case of the exposure scenario of compounding of polystyrene resin to produce XPS masterbatch, EPA estimated HBCD inhalation exposure concentrations to be equal to the assessed exposure concentrations reported in the EURAR ([ECHA 2008b](#)) that pertain to all polymer processing operations involving standard grade HBCD. Specifically, EPA estimated high-end and central tendency exposure concentrations to be equal to the "reasonable worst-case" exposure concentration of the EURAR of 2.5 mg/m³ and the "typical" exposure concentration of the EURAR of 1.25 mg/m³, respectively. Refer to Section 2.4.1.3 for the discussion of these data of the EURAR.

Dermal Exposure Assessment

As described in Section 2.4.1.1. EPA calculated dermal exposure assuming two-hand contact to solid containing 100% HBCD ([NICNAS 2012b](#); [ECHA 2008b](#)). EPA used this weight fraction because workers at sites that produce XPS foam from HBCD powder have the highest potential dermal exposure concentration to HBCD during the unloading of HBCD powder. Using this model and 100% HBCD, EPA calculated the potential dose for a worker to be 3,100 mg HBCD/day (high-end) and 900 mg HBCD/day (central tendency).

The EURAR estimated dermal exposure for the use of HBCD standard grade powder as an additive in XPS masterbatch and XPS foam manufacturing. The EASE model estimated this exposure to be 0.1

mg/cm²-day. Using EPA's two-hand surface area of 1,070 cm², this results in a dose of 107 mg/day. The NICNAS report uses EASE to model dermal exposure during the addition and weighing of HBCD into processes. EASE estimated a dermal dose rate of 0.1 to 1 mg/cm²-day. Using EPA's two-hand surface area of 1,070 cm², this results in a dose of 107 to 1,070 mg/day. The EASE estimates provided in the EURAR and NICNAS are lower than that estimated by EPA (3,100 mg/day) as the *EPA/OPPT Direct 2-Hand Dermal Contact with Solids Model* predicts a higher quantity of solids on skin per day.

Strengths, Limitations, and Confidence in Assessment Results

EPA has medium confidence in the assessed inhalation exposure concentrations presented above. EPA considered the quality of the data, the assessment approach, and uncertainties in assessment results to determine the level of confidence.

The result of EPA's systematic review is inhalation exposure monitoring data with an overall confidence rating of high which is a strength of the assessment. The strength of the assessment approach is the estimation of inhalation exposure concentrations based on inhalation exposure concentration monitoring data that (a) are the preferred type of monitoring data (*i.e.*, 8-hr TWA personal breathing zone data), (b) are surrogate data pertaining to a worker activity that is certainly relevant to the assessed exposure scenario, and (c) comprise multiple datasets.

The limitation of the assessment approach is the estimation of inhalation exposure concentrations based on worker monitoring data that pertain to the worker activity that is expected to result in the largest exposure but that do not pertain to other worker activities.

There is uncertainty in the estimated HBCD potential inhalation exposure concentrations because the bases of these concentrations are data that pertain to workers in Europe and the extent to which these concentrations represent the distribution of inhalation exposure air concentrations pertaining to workers in the U.S. is uncertain. Refer to Section 2.4.1.14 for additional discussion of uncertainty. Based on these strengths, limitation, and uncertainty, EPA has medium confidence in the assessed occupational inhalation exposure air concentrations.

2.4.1.6 Processing of HBCD to Produce EPS Foam from Imported EPS Resin Beads

EPS foam is produced from EPS resin beads by conditioning the beads and using molds to form blocks of foam (further described in Section 2.2.6), and then followed by the secondary processing of the foam. The secondary processing of EPS foam include the cutting, sawing and machining of EPS foam ([ECHA, 2008b](#)). This is done to produce sheets or customer-required shapes ([NICNAS, 2012b](#)), and results in cuttings and sawdust that are recycled within the plant ([ECHA, 2008b](#)); the cuttings are granulated prior to recycle ([NICNAS, 2012b](#)). Worker exposure to HBCD as a result of the conditioning of beads and the formation of foam in molds is expected to be low based on the process description and because HBCD is encapsulated in the EPS resin beads at a low concentration (<1 wt%) ([NICNAS, 2012b](#)). According to HBCD importers in Australia, the cutting of XPS/EPS foam by manually sawing it or by using a hot wire is unlikely to produce inhalable particles ([NICNAS, 2012b](#)). The EURAR ([ECHA, 2008b](#)) does not include an assessment of occupational exposure pertaining to the manufacture of EPS foam from EPS resin beads. According to the EURAR ([ECHA, 2008b](#)) worker exposure resulting from the cutting of XPS/EPS foam that generates dust and from heating XPS/EPS with a hot wire is probably lower than exposure resulting from handling of pure HBCD. EPA assessed potential worker and ONU exposure to the dust that is generated during the secondary processing of EPS foam.

Number of Potentially Exposed Workers and Occupational Non-Users

The 2016 CDR data identifies multiple submissions that claim the industrial use in the “construction” and “plastics product manufacturing” sectors ([U.S. EPA 2016c](#)). These industrial sectors are broad and can include a variety of sites, including sites that do not product or install XPS and EPS foam, thus the reported estimates of number of workers potentially exposed at these sites may not be applicable to this exposure scenario.

EPA used workers and ONU estimates determined from an analysis of BLS data for the NAICS code 326140, Polystyrene Foam Product Manufacturing. These data indicate that there are, on average, 20 workers and 6 ONUs per site within NAICS code 326140. Based on these data and one modeled site for the manufacturing of EPS foam from imported EPS resin beads, EPA estimated that a total of 20 workers and 6 ONUs are potentially exposed during this exposure scenario.

Inhalation Exposure Assessment

EPA estimated HBCD potential inhalation exposure concentrations to be equal to surrogate HBCD occupational inhalation exposure concentration monitoring data. The surrogate monitoring data pertain to the secondary processing of XPS foam which is part of the process of the manufacture of XPS Foam using XPS masterbatch.

The EURAR ([ECHA, 2008b](#)) includes worker inhalation exposure monitoring data pertaining to the secondary processing of XPS foam but this process is not described. EPA assumed this process is similar to the secondary processing of EPS foam because the manufacture of XPS foam includes the trimming of XPS foam to desired shapes ([ECHA, 2008b](#)). Based on this, EPA determined the worker inhalation exposure monitoring data pertaining to the secondary processing of XPS foam to be surrogate data. This monitoring data is the data of Searl and Robertson ([2005](#)), which is presented in Table 2-74 and noted in this table as 5a. EPA estimated central tendency and high-end exposure concentrations to be equal to the mean value of 0.08 mg/m³, and the 90th percentile value of 0.22 mg/m³ of the surrogate monitoring data, respectively. Refer to Section 2.4.1.4 for a discussion of this monitoring data. Cutting of EPS foam can be done by machine using sawing or hot wire cutting or by handsaw ([NICNAS, 2012b](#).) Hence, as discussed in Section 2.4.1.1, workers are possibly exposed to HBCD nanoparticles as a result of cutting of EPS foam with a hot wire.

As discussed in Section 2.2.6, EPA estimated a range of release days of 16 to 140 days/year. EPA expects this range of release days is also reflective of the operating days during which HBCD is processed at a converting site and workers are potentially exposed to HBCD. EPA used the midpoint of this range of exposure frequency, rounded up where the midpoint resulted in fractions of days, to calculate central tendency average daily dose. EPA used the high-end of this range of exposure frequency to calculate high-end average daily dose. Additionally, EPA estimated worker exposure over the full working day, or eight hours/day, as the data used to estimate inhalation exposures is 8-hour TWA data.

Dermal Exposure Assessment

EPA did not find data on potential levels of dermal exposure for workers engaged in activities related to the production of EPS foam from EPS resin beads. The EURAR and Australian risk assessment did not assess dermal exposures during this exposure scenario ([NICNAS 2012b](#); [ECHA 2008b](#)). HBCD is entrained in the imported EPS resin beads and the potential dermal exposure from handling EPS and XPS foams containing HBCD is low due to the small weight fraction of HBCD in the foam and because HBCD is incorporated into the foam matrix, thus is not readily available for exposure ([NICNAS 2012b](#);

[ECHA 2008b](#)). Due to the same considerations, dermal exposures to HBCD during this exposure scenario are not expected.

Strengths, Limitations, and Confidence in Assessment Results

EPA has low to medium confidence in the assessed inhalation exposure concentrations presented above. EPA considered the quality of the data, the assessment approach, and uncertainties in assessment results to determine the level of confidence.

The result of EPA's systematic review is inhalation exposure monitoring data with an overall confidence rating of high which is a strength of the assessment. The strength of the assessment approach is the estimation of inhalation exposure concentrations to be equal to surrogate occupational inhalation exposure concentration monitoring data.

The limitations of the assessment approach are the following: (a) the worker monitoring data that are the basis of the estimated inhalation exposure concentrations are not the preferred type because the type of sampling (personal breathing zone or area monitoring) is not reported for this data and (b) potential worker exposure resulting from hot wire cutting of EPS foam is not estimated.

The uncertainty in the estimated HBCD potential inhalation exposure concentrations are as follows. First, as discussed Section 2.4.1.4, most of the worker monitoring data that are the basis of the estimated inhalation exposure concentrations are non-detects (specifically, three or fewer of the total of nine samples are non-detects.) Second, there is uncertainty about the extent to which the surrogate inhalation exposure concentration monitoring data are valid surrogate data because EPA is uncertain that the secondary processing of XPS foam and the secondary processing of EPS foam are equivalent in terms of worker exposure. Third, the extent to which the estimated occupational inhalation exposure concentration data, which are data that pertain to workers in Europe, represent the distribution of inhalation exposure air concentrations pertaining to workers in the U.S. is uncertain. Refer to Section 2.4.1.14 for additional discussion of uncertainty. Based on these strengths, limitation, and uncertainties, EPA has low to medium confidence in the assessed occupational inhalation exposure air concentrations.

Table 2-76. Summary of Inhalation Monitoring Data for Handling of XPS and EPS Foam Containing HBCD

Literature Study ^a	Exposure Scenario	Form of HBCD Handled	Type of Sample	Worker Activity or Sampling Location	Exposure Concentration (mg/m ³) ^b	Number of Samples	Sample Time / Type of Measurement	Source	Overall Confidence Rating
Inhalation Monitoring Data Used to Estimate Worker Exposure									
Searl and Robertson (2005) - 5a	Manufacture of XPS from XPS Masterbatch	HBCD in XPS foam	NR	Secondary processing of XPS foam	Mean: 0.08 90th percentile: 0.22 ^c	9	8-hr TWA	Original source: (Searl and Robertson 2005) Reported in: (ECHA 2008b); (ECHA 2009b)	High
Other Inhalation Monitoring or Air Concentration Data for the Handling of XPS and EPS Foam									
Searl and Robertson (2005) - 5b	Manufacture of XPS from XPS Masterbatch	HBCD in XPS foam	NR	Reclamation of XPS foam - including shredding and reprocessing of process waste	Mean: 0.02 90th percentile: 0.02 ^c	5	8-hr TWA	Original source: (Searl and Robertson 2005) Reported in: (ECHA 2008b); (ECHA 2009b)	High
Searl and Robertson (2005) - 5c	Manufacture of XPS from XPS Masterbatch	Uncertain: HBCD in XPS foam or XPS Masterbatch	NR	Other process control operators	Mean: 0.03 90th percentile: 0.03 ^c	4	8-hr TWA	Original source: (Searl and Robertson 2005) Reported in: (ECHA 2008b); (ECHA 2009b)	High
NR = Not Reported; N/A = Not Applicable a - Where multiple datasets were available from one literature source, EPA distinguished data as 1a, 1b, 2a, 2b, etc. b - The statistical values were obtained from the referenced literature source and were not calculated by EPA.									

2.4.1.7 Processing of HBCD to Produce SIPs and Automobile Replacement Parts from XPS/EPS Foam

Workers are likely to manually unwrap and further handle the XPS and EPS foam boards during which they will likely have dermal contact with the foam; however, HBCD is expected to be incorporated in the foam matrix and not readily available for exposure ([NICNAS 2012b](#)). Attrition of the foam boards during transportation to sites at which SIPs and automobile replacement parts are manufactured is unlikely because of the large size of the boards and the limited opportunity for rubbing of boards against each other. Therefore, worker inhalation exposure during unwrapping of the boards to dust resulting from the attrition of the boards is unlikely ([U.S. EPA 2014a](#)). To manufacture SIPs, the XPS and EPS foam is cut into the desired size panel, either with saws or thermal wires ([NICNAS 2012b](#); [ECHA 2008b](#)). The panels are then adhered to steel, plastic, concrete, plasterboard, or other sheathing material on either side, forming a sandwich, which is why these panels are also referred to as sandwich panels ([NICNAS 2012b](#)). Once the SIPs are produced, they are shipped to construction sites for installation.

Cutting of the XPS and EPS foam results in particle generation that pose potential for worker and ONU inhalation exposure.

Number of Potentially Exposed Workers and Occupational Non-Users

EPA estimated exposures for workers at two sites based on the methodology described in Section 2.4.1.1. The 2016 CDR data identify multiple submissions that claim the industrial use in the “construction” and “plastics product manufacturing” sectors ([U.S. EPA 2016c](#)). These industrial sectors can include a variety of sites, including XPS and EPS foam sites and construction sites, thus the reported estimates of number of workers potentially exposed at these sites may not be applicable to this exposure scenario.

EPA used workers and ONU estimates determined from an analysis of BLS data for the NAICS code 326140, Polystyrene Foam Product Manufacturing. These data indicate that there are, on average, 20 workers and 6 ONUs per site within NAICS code 326140. Based on these data and one site for each of the SIPs and automobile replacement part production, EPA estimated that a total of 39 workers and 11 ONUs are potentially exposed during this exposure scenario. EPA used unrounded figures for the number of workers and ONUs per site to calculate these totals, resulting in the slight discrepancy.

Inhalation Exposure Assessment

EPA estimated HBCD potential inhalation exposure concentrations to be equal to surrogate HBCD occupational inhalation exposure concentration monitoring data. The surrogate monitoring data pertain to the secondary processing of XPS foam which is part of the process of the manufacture of XPS Foam using XPS masterbatch.

The EURAR ([ECHA, 2008b](#)) includes worker inhalation exposure monitoring data pertaining to the secondary processing of XPS foam but this process is not described. As discussed in Section 2.4.1.6, EPA assumed this process is similar to the secondary processing of EPS foam and hence comprises cutting, sawing and/or machining of XPS foam. Based on this, EPA determined the worker inhalation exposure monitoring data pertaining to the secondary processing of XPS foam to be surrogate data. These monitoring data are the data of Searl and Robertson ([2005](#)), which is presented in Table 2-75 and noted in this table as 5a. EPA estimated central tendency and high-end exposure concentrations to be equal to the mean value of 0.08 mg/m³, and the 90th percentile value of 0.22 mg/m³ of the surrogate monitoring data, respectively. Refer to Section 2.4.1.4 for a discussion of this monitoring data. As

discussed in Section 2.4.1.1, workers are possibly exposed to HBCD nanoparticles as a result of cutting of EPS foam with a hot wire.

As discussed in Section 2.2.7, EPA estimated a range of release days of 16 to 300 days/year. EPA expects this range of release days is also reflective of the operating days during which HBCD is processed at foam cutting sites and workers are potentially exposed to HBCD. However, EPA does not expect that workers will be exposed greater than 250 day/year, accounting for a worker schedule of five days per week and 50 weeks per year. Based on this, EPA estimated worker exposures over a range of 16 to 250 days/year. EPA used the midpoint of this range of exposure frequency, rounded up where the midpoint resulted in fractions of days, to calculate central tendency average daily dose. EPA used the high-end of this range of exposure frequency to calculate high-end average daily dose. Additionally, EPA estimated worker exposure over the full working day, or eight hours/day, as the data used to estimate inhalation exposures is 8-hour TWA data.

Dermal Exposure Assessment

EPA did not find data on potential levels of dermal exposure for workers engaged in activities related to the manufacturing of SIPs and automobile replacement parts from XPS and EPS foam. The EURAR and Australian risk assessment did not assess dermal exposures during this exposure scenario, with both reports stating that these exposures are expected to be low because HBCD is incorporated into the foam matrix, thus is not readily available for exposure ([NICNAS 2012b](#); [ECHA 2008b](#)). The potential dermal exposure from handling EPS and XPS foams containing HBCD is low due to the small weight fraction of HBCD in the foam and because HBCD is incorporated into the foam matrix, thus is not readily available for exposure ([NICNAS 2012b](#); [ECHA 2008b](#)). Due to the same considerations, dermal exposures to HBCD during this exposure scenario are not expected.

Strengths, Limitations, and Confidence in Assessment Results

EPA has low to medium confidence in the assessed inhalation exposure concentrations presented above. EPA considered the quality of the data, the assessment approach, and uncertainties in assessment results to determine the level of confidence.

The result of EPA's systematic review is inhalation exposure monitoring data with an overall confidence rating of high which is a strength of the assessment. The strength of the assessment approach is the estimation of inhalation exposure concentrations to be equal to surrogate occupational inhalation exposure concentration monitoring data.

The limitations of the assessment approach are the following: (a) the worker monitoring data that are the basis of the estimated inhalation exposure concentrations are not the preferred type because the type of sampling (personal breathing zone or area monitoring) is not reported for this data and (b) potential worker exposure resulting from hot wire cutting of EPS foam is not estimated.

The uncertainty in the estimated HBCD potential inhalation exposure concentrations are as follows. First, as discussed in Section 2.4.1.4, most of the worker monitoring data that are the basis of the estimated inhalation exposure concentrations are non-detects (specifically, three or fewer of the total of nine samples are non-detects.) Second, there is uncertainty about the extent to which the surrogate inhalation exposure concentration monitoring data are valid surrogate data because EPA is uncertain that the secondary processing of XPS foam and the manufacture of SIPs and replacement auto parts from XPS/EPS foam are equivalent in terms of worker exposure. Third, the extent to which the estimated occupational inhalation exposure concentration data, which are data that pertain to workers in Europe,

represent the distribution of inhalation exposure air concentrations pertaining to workers in the U.S. is uncertain. Refer to Section 2.4.1.14 for additional discussion of uncertainty. Based on these strengths, limitation, and uncertainties, EPA has low to medium confidence in the assessed occupational inhalation exposure air concentrations.

2.4.1.8 Use: Installation of Automobile Replacement Parts

EPA does not expect that workers at automobile repair sites further process the replacement parts containing HBCD. Because the automobile replacement parts are received at repair shops as finished articles containing XPS and EPS foam, in which HBCD is incorporated into the foam matrix, inhalation and dermal exposures are not expected ([NICNAS 2012b](#); [ECHA 2008b](#)).

2.4.1.9 Use: Installation of XPS/EPS Foam Insulation in Residential, Public and Commercial Buildings, and Other Structures

Workers may saw or cut XPS/EPS foam boards at construction sites ([ECHA, 2008b](#)). The boards are sawed with a bandsaw or manually ([NICNAS 2012b](#)) and cut with a knife or a hot wire ([NICNAS 2012b](#); [ECHA 2008b](#)). The EURAR and NICNAS do not include an assessment of the occupational exposure scenario. According to HBCD importers in Australia, the cutting of XPS/EPS foam boards by manually sawing it or by using a hot wire is unlikely to produce inhalable particles but NICNAS does not include any corroborating data ([NICNAS, 2012b](#)). According to the EURAR ([ECHA, 2008b](#)), worker exposure resulting from the cutting of XPS/EPS foam boards that generates dust and from heating XPS/EPS with a hot wire is probably lower than exposure resulting from handling of pure HBCD. As discussed in Section 2.2.9, the amounts of XPS/EPS particles generated from sawing and cutting XPS/EPS foam boards are reported in the EURAR but the particle sizes are not given. EPA assessed potential worker exposure to the dust that is generated during the sawing or cutting of XPS/EPS foam boards. ONUs may inhale this dust.

Number of Potentially Exposed Workers and Occupational Non-Users

As discussed in Section 2.2.9, EPA estimated the number of potential construction sites to be as few as 34 large construction sites (assumes HBCD use rate estimated for large-scale use) and as high as 2,696 residential construction sites (assumes HBCD use rate estimated for residential use) may install insulation containing HBCD in a year.

EPA analyzed information from the Bureau of Labor Statistics for the NAICS code 238310, Drywall and Insulation Contractors, to determine an estimate of the number of workers and ONUs that may be present at a construction site. These data indicate that there are, on average, 8 workers and 1 ONU per contractor establishment within NAICS code 238310. Due to the low estimate of workers and ONUs per establishment, EPA assumes that this estimate represents the size of one work crew and that one crew would be present at job sites (*i.e.*, construction sites) at a given time. Thus, EPA estimated 8 workers and 1 ONU per job site. Furthermore, EPA assumes that different crews from separate contractor establishments may install insulation containing HBCD and that these crews may install insulation containing HBCD at more than one job site in a year, although there is the potential for variability.

Using these data for number of workers and ONUs and the lower value estimate of 34 construction sites, a total of approximately 310 workers and 30 ONUs are potentially exposed. Using these data and the upper value estimate of 2,696 residential construction sites, a total of approximately 25,000 workers and 2,400 ONUs are potentially exposed. EPA expects that this range accounts for both the scenario that job crews may install insulation containing HBCD at multiple sites through a year and the scenario that a job crew will only install insulation containing HBCD at one site in a year. These data are summarized in Table 2-77. EPA used unrounded figures for the number of workers and ONUs per site to calculate

these totals, resulting in the slight discrepancy. EPA recognizes that smaller residential sites likely have fewer workers than larger sites, thus this is likely an overestimate of the number of potentially exposed people.

Table 2-77. U.S. Number of Establishments and Employees for Installation of XPS/EPS Foam Insulation in Residential, Public and Commercial Buildings, and Other Structures

2016 NAICS	2016 NAICS Title	Number of Job Sites		Number of Workers per Site ^a	Number of ONUs per Site ^a
		Lower value (large commercial sites)	Upper value (residential sites)		
238310	Drywall and Insulation Contractors	34	2,696	9	1
<i>Lower value of total establishments and number of potentially exposed workers and ONUs =^b</i>		34		310	30
<i>Upper value of total establishments and number of potentially exposed workers and ONUs =^b</i>		2,696		25,000	2,400

a – Rounded to the nearest whole number and two significant figures.

b – Unrounded figures were used for total worker and ONU calculations.

Inhalation Exposure Assessment

EPA estimated HBCD potential inhalation exposure concentrations to be equal to surrogate HBCD occupational inhalation exposure concentration monitoring data. The surrogate monitoring data pertain to the secondary processing of XPS foam which is part of the process of the manufacture of XPS Foam using XPS masterbatch.

The EURAR ([ECHA, 2008b](#)) includes worker inhalation exposure monitoring data pertaining to the secondary processing of XPS foam but this process is not described. As discussed in Section 2.4.1.6, EPA assumed this process is similar to the secondary processing of EPS foam and hence comprises cutting, sawing and/or machining of XPS foam. Based on this, EPA determined the worker inhalation exposure monitoring data pertaining to the secondary processing of XPS foam to be surrogate data. These monitoring data are the data of Searl and Robertson ([2005](#)), which is presented in Table 2-74 and noted in this table as 5a. EPA estimated central tendency and high-end exposure concentrations to be equal to the mean value of 0.08 mg/m³, and the 90th percentile value of 0.22 mg/m³ of the surrogate monitoring data, respectively. Refer to Section 2.4.1.4 for a discussion of this monitoring data. As discussed in Section 2.4.1.1, workers are possibly exposed to HBCD nanoparticles as a result of cutting of EPS foam with a hot wire.

As discussed in Section 2.2.9, EPA estimated a range of release days of 1 to 3 days/year-site. However, EPA expects that workers may install insulation containing HBCD at multiple sites in a year. EPA does not expect that workers will be exposed greater than 250 day/year, accounting for a worker schedule of five days per week and 50 weeks per year. Based on this, EPA expects the minimum number of exposure days to be 1 day/per year and the maximum number of exposure days to be 250 days/year. EPA used the midpoint of the range of 1 to 250 days/year of exposure frequency, rounded up to 126 days/year, to calculate central tendency average daily dose. EPA used the high-end of this range of

exposure frequency to calculate high-end average daily dose. Additionally, EPA estimated worker exposure over the full working day, or eight hours/day, as the data used to estimate inhalation exposures is 8-hour TWA data.

Dermal Exposure Assessment

The EURAR and Australian risk assessment did not assess dermal exposures during this exposure scenario ([NICNAS 2012b](#); [ECHA 2008b](#)), stating that these exposures are expected to be low. The potential dermal exposure from handling XPS and EPS foams containing HBCD is low due to the small weight fraction of HBCD in the foam and because HBCD is incorporated into the foam matrix, thus is not readily available for exposure ([NICNAS 2012b](#); [ECHA 2008b](#)). EPA does not expect dermal exposures during this exposure scenario due to the same considerations.

Strengths, Limitations, and Confidence in Assessment Results

EPA has low to medium confidence in the assessed inhalation exposure concentrations presented above. EPA considered the quality of the data, the assessment approach, and uncertainties in assessment results to determine the level of confidence.

The result of EPA's systematic review is inhalation exposure monitoring data with an overall confidence rating of high which is a strength of the assessment. The strength of the assessment approach is the estimation of inhalation exposure concentrations to be equal to surrogate occupational inhalation exposure concentration monitoring data.

The limitations of the assessment approach are the following: (a) the worker monitoring data that are the basis of the estimated inhalation exposure concentrations are not the preferred type because the type of sampling (personal breathing zone or area monitoring) is not reported for this data and (b) potential worker exposure resulting from hot wire cutting of EPS foam is not estimated.

The uncertainty in the assessment results are as follows. First, as discussed in Section 2.4.1.4, most of the worker monitoring data that are the basis of the estimated inhalation exposure concentrations are non-detects (specifically, three or fewer of the total of nine samples are non-detects.) Second, there is uncertainty about the extent to which the surrogate inhalation exposure concentration monitoring data are valid surrogate data because EPA is uncertain that the secondary processing of XPS foam and the sawing or cutting of XPS/EPS foam at construction sites are equivalent in terms of worker exposure because the methods and frequencies of sawing or cutting of XPS/EPS foam boards at construction sites and the ventilation rates at these sites may be different than the values of these parameters in the case of industrial sites at which the secondary processing of XPS foam occurs. Refer to Section 2.4.1.14 for additional discussion of uncertainty. Based on these strengths, limitation, and uncertainties, EPA has low to medium confidence in the assessed occupational inhalation exposure air concentrations.

2.4.1.10 Demolition and Disposal of XPS/EPS Foam Insulation Products in Residential, Public and Commercial Buildings, and Other Structures

EPA expects workers may break XPS and EPS foam insulation products during demolition, which may generate dust that contains HBCD that workers and ONUs may inhale. The waste from demolition sites will most likely be sent to construction & demolition landfills, incineration facilities, or recycled. Insulation waste containing HBCD may be further broken down via shredders, or other equipment at landfill and incineration facilities. Workers and ONUs at these facilities may be exposed to dust containing HBCD. Occupational exposures during recycling is discussed in Section 2.4.1.11 Recycling of EPS foam and Reuse of XPS foam.

Solid waste may be first sent to waste transfer facilities, where waste is consolidated onto larger trucks. At many transfer stations, workers screen incoming waste located on conveyor systems, tipping floors, or in waste pits to identify recyclables and wastes inappropriate for disposal (*e.g.*, hazardous waste, whole tires). Workers at transfer stations operate heavy machinery such as conveyor belts, push blades, balers, and compactors, and may also clean the facility or perform equipment maintenance. Workers may be exposed to poor air quality due to dust and odor, particularly in tipping areas over waste pits (<https://www.epa.gov/sites/production/files/2016-03/documents/r02002.pdf>). As reported for a municipal landfill facility, waste may be dumped onto tipping floors for storage, then fed to a conveyor system for sorting and eventual shredding of waste. The waste from these processes are either directly loaded on trucks to be sent into the landfill or deposited in storage pits ([Burkhart and Short 1995](#)). Heavy machinery operators may be exposed to particulates and other contaminants while in the cabs of the machinery (<https://www.cdc.gov/niosh/hhe/reports/pdfs/1996-0109-2616.pdf> and <https://www.cdc.gov/niosh/hhe/reports/pdfs/1993-0696-2395.pdf>). Mechanics servicing equipment may be exposed to residues on machinery. In addition, workers may be exposed when removing dirty work uniforms (<https://www.cdc.gov/niosh/hhe/reports/pdfs/1996-0109-2616.pdf>). EPA expects similar processing of waste may occur at C&D landfills.

At Municipal Waste Combustors (MWCs), waste materials are not generally handled directly by workers. Trucks may dump the waste directly into the pit, or waste may be tipped to the floor and later pushed into the pit by a worker operating a front-end loader. A large grapple from an overhead crane is used to grab waste from the pit and drop it into a hopper, where hydraulic rams feed the material continuously into the combustion unit at a controlled rate.

Facilities that used the refuse-derived fuel (RDF) process may conduct on-site sorting, shredding, and inspection of the waste prior to incineration to recover recyclables and remove hazardous waste or other unwanted materials. Sorting is usually an automated process that uses mechanical separation methods, such as trommel screens, disk screens, and magnetic separators. Once processed, the waste material may be transferred to a storage pit, or it may be conveyed directly to the hopper for combustion. Tipping floor operations may generate dust. Air from the enclosed tipping floor, however, is continuously drawn into the combustion unit via one or more forced air fans to serve as the primary combustion air and minimize odors. Dust and lint present in the air is typically captured in filters or other cleaning devices in order to prevent the clogging of steam coils, which are used to heat the combustion air and help dry higher-moisture inputs ([Kitto 1992](#)).

Number of Potentially Exposed Workers and Occupational Non-Users

EPA did not find information regarding the number of workers typically on a demolition site. To estimate the number of workers potentially exposed per site, EPA assumed that demolition is accomplished by workers who remove the insulation, as the insulation may be recycled or reused as discussed in Section 2.2.11. To estimate the number of these workers, EPA assumed that this number of workers is equivalent to the number of workers who install foam panels and utilized the same methodology for estimating workers potentially exposed during the installation of insulation into buildings, as described below and in Section 2.4.1.9.

As described in Section 2.4.1.9, EPA analyzed information from the Bureau of Labor Statistics (BLS) for the NAICS code 238310, Drywall and Insulation Contractors, to determine an estimate of the number of workers and ONUs that may be present at a demolition site. These data indicate that there are, on average, 8 workers and 1 ONU per contractor establishment within NAICS code 238310. Using these data for number of workers and ONUs and the lower value estimate of 578 demolition sites, a total of

approximately 5,300 workers and 510 ONUs are potentially exposed. Using these data and the upper value estimate of 45,832 residential demolition sites, a total of approximately 420,000 workers and 40,000 ONUs are potentially exposed.

For potential workers handling C&D waste, EPA reviewed data from the BLS for NAICS code 562212, Solid Waste Landfill, and related Standard Occupational Classification (SOC) codes, there are on average an estimated 3 workers and 2 ONUs per site at landfill facilities. An analysis using the BLS for NAICS code 562219, Other Nonhazardous Waste provided the same estimate. Using BLS for NAICS code 562213, Solid Waste Combustors and Incinerators, and related SOC codes, there are on average an estimated 13 workers and 8 ONUs per incineration site. As stated in Section 2.2.10, EPA identified estimates of 1,120 to 1,577 active C&D landfills and up to 107 waste-to-energy facilities in the U.S. It is likely that some of these facilities may not receive insulation waste containing HBCD, depending on the type of waste accepted at the facility and prevalence of XPS/EPS foam insulation containing HBCD in nearby areas. An upper bound estimate would be 4,731 workers and 3,154 ONUs for solid waste landfills and 1,391 workers and 856 ONUs for solid waste incinerators.

Inhalation Exposure Assessment

EPA estimated HBCD potential inhalation exposure concentrations in accordance with an estimation method that is based on the Occupational Safety and Health Administration (OSHA) permissible exposure limit (PEL) for particulates not otherwise regulated (PNOR) ([U.S. EPA, 2013a](#)). That is, EPA estimated the HBCD potential inhalation exposure concentrations by multiplying the OSHA PEL for PNOR, which is 15 mg/m³ for total dust, by the HBCD concentration in XPS and EPS foam, which are 2 wt% and 0.7 wt%, respectively ([ECHA 2008b](#)). This modeling approach assumes that dust generated is only from XPS/EPS foam and is proportional to the concentration of HBCD in the foam. Hence, EPA calculated potential HBCD exposure concentrations ranging from 0.105 to 0.30 mg/m³. The OSHA PEL for PNOR and EPA's estimate are 8-hour TWA values. The specific value of exposure concentration using this method is dependent on the proportion of each type of foam, XPS and/or EPS, being broken down.

EPA considered the use of the data discussed in Section 2.4.1.4, which is data for workers performing secondary processing of XPS foam, which includes cutting, sawing, or machining of XPS foam. EPA did not use these data as surrogate for this exposure scenario because, based on the process description, EPA does not expect the use of the same tools for breaking down of foam in this exposure scenario as those used for the secondary processing of XPS foam at an XPS foam manufacturing site, resulting in different dust generation potential. Specifically, as discussed in the process description, this exposure scenario involves manually breaking foam insulation, demolishing with equipment such as a wrecking ball, or shredding of foam during waste processing. Based on the process description, the land disposal for the most part does not involve the intentional breaking of waste although some processing steps such as compaction and loading and unloading of waste may result in the breaking of articles. This approach likely overestimates exposure experienced by workers at landfills as discussed below in strengths, limitations, and confidence in assessment results.

As discussed in Section 2.2.10, EPA estimated a range of release days of 1 to 3 days/year-job site for demolition sites. However, EPA expects that workers may demolish insulation containing HBCD at multiple sites in a year. Landfill and incineration operations are expected to run year-round. EPA does not expect that workers will be exposed greater than 250 day/year, accounting for a worker schedule of five days per week and 50 weeks per year. Based on this, EPA expects the minimum number of exposure days to be 1 day/per year and the maximum number of exposure days to be 250 days/year.

Workers may only perform demolition activities intermittently throughout a year. EPA believes the upper estimate of 250 days/year is likely an overestimate for demolition workers but does not have any data to estimate the exact number of working days. EPA used the midpoint of the range of 1 to 250 days/year of exposure frequency, rounded up to 126 days/year, to calculate central tendency average daily dose. EPA used the high-end of this range of exposure frequency to calculate high-end average daily dose. Additionally, EPA estimated worker exposure over the full working day, or eight hours/day, as the data used to estimate inhalation exposures is 8-hour TWA limit.

Dermal Exposure Assessment

The EURAR and Australian risk assessment did not assess dermal exposures during this exposure scenario ([NICNAS 2012b](#); [ECHA 2008b](#)). The potential dermal exposure from handling XPS and EPS foams containing HBCD is low due to the small weight fraction of HBCD in the foam and because HBCD is incorporated into the foam matrix, thus is not readily available for exposure ([NICNAS 2012b](#); [ECHA 2008b](#)). EPA does not expect dermal exposures to HBCD during this exposure scenario due to the same considerations.

Strengths, Limitations, and Confidence in Assessment Results

EPA has low to medium confidence in the assessed inhalation exposure concentrations presented above. EPA considered the uncertainties in assessment results to determine the level of confidence. EPA is uncertain about the extent to which the OSHA PEL for PNOR is representative of occupational inhalation exposure air concentrations during demolition of buildings and other structures and the processing of waste. Inherent to EPA's approach is the assumption that XPS/EPS foam is the source of all the dust that is generated and this assumption likely results in an overestimate of exposure concentrations. In particular, EPA expects inhalation exposures for workers at landfill and incineration facilities to be overestimated. Insulation waste is only a small contributor to waste received at C&D landfills and site-specific processes may not involve the intentional breaking of waste. EPA estimates concrete and wood products composed the largest proportion of waste materials at C&D landfills ([U.S. EPA 2018a](#)). Based on these strengths, limitation, and uncertainty, EPA has low to medium confidence in the assessed occupational inhalation exposure air concentrations.

2.4.1.11 Recycling of EPS Foam and Reuse of XPS Foam

EPS boards are recycled by grinding them and feeding the grinded material to the molding process together with virgin EPS to form new boards ([ECHA 2008b](#)). As discussed in Section 1.2.6, in the U.S. the EPS produced by recycling EPS insulation boards is taken to polystyrene product manufacturers. EPA assumes that the recycling of EPS insulation boards may include secondary processing of EPS, which is a part of the process for manufacture of EPS from EPS resin beads and can be the cutting, sawing and machining of the EPS foam ([ECHA, 2008b](#)). As discussed in Section 2.4.1.6, EPA believes the secondary processing of EPS may result in potential worker and ONU inhalation exposure to the dust that is generated during this process and hence EPA assessed worker potential exposure.

Number of Potentially Exposed Workers and Occupational Non-Users

EPA estimated exposures for workers at two recycling and reuse sites based on the information in Section 2.2.11. As discussed above, EPS recycling is likely to be performed at sites with similar operations to those described for EPS foam manufacturing in Section 2.2.6. Thus, EPA assumed the same number of workers and ONUs as described in Section 2.4.1.6 (Processing of HBCD to Produce EPS Foam from Imported EPS Resin Beads). For this estimate, EPA utilized worker and ONU estimates determined from an analysis of BLS data for the NAICS code 326140, Polystyrene Foam Product Manufacturing. These data indicate that there are, on average, 20 workers and 6 ONUs per site within NAICS code 326140. Based on these data and two sites for the recycling of EPS foam and reuse of XPS,

EPA estimated that a total of 39 workers and 11 ONUs are potentially exposed during this life cycle stage. EPA used unrounded figures for the number of workers and ONUs per site to calculate these totals, resulting in the slight discrepancy.

EPA notes that the number of workers potentially exposed during reuse of XPS may differ from the estimate above, if XPS is reused directly at construction sites and is not first processed (*i.e.*, cut or otherwise re-shaped) at industrial processing sites.

Inhalation Exposure Assessment

EPA estimated HBCD potential inhalation exposure concentrations to be equal to surrogate HBCD occupational inhalation exposure concentration monitoring data. The surrogate monitoring data pertain to the secondary processing of XPS foam which is part of the process of the manufacture of XPS Foam.

The EURAR ([ECHA, 2008b](#)) includes worker inhalation exposure monitoring data pertaining to the secondary processing of XPS foam but this process is not described. As discussed in Section 2.4.1.6, EPA assumed this process is similar to the secondary processing of EPS foam and hence comprises cutting, sawing and/or machining of XPS foam. Based on this, EPA determined the worker inhalation exposure monitoring data pertaining to the secondary processing of XPS foam to be surrogate data. These monitoring data are the data of Searl and Robertson ([2005](#)), which is presented in Table 2-75 and noted in this table as 5a. EPA estimated central tendency and high-end exposure concentrations to be equal to the mean value of 0.08 mg/m³, and the 90th percentile value of 0.22 mg/m³ of the surrogate monitoring data, respectively. Refer to Section 2.4.1.4 for a discussion of this monitoring data.

As discussed in Section 2.2.11, EPA estimated a range of release days of 1 to 140 days/year. EPA expects this range of release days is also reflective of the operating days during which foam containing HBCD is recycled at a converting site and workers are potentially exposed to HBCD. EPA used the midpoint of this range of exposure frequency, rounded up where the midpoint resulted in fractions of days, to calculate central tendency average daily dose. EPA used the high-end of this range of exposure frequency to calculate high-end average daily dose. Additionally, EPA estimated worker exposure over the full working day, or eight hours/day, as the data used to estimate inhalation exposures is 8-hour TWA data.

Dermal Exposure Assessment

EPA did not find data on potential levels of dermal exposure for workers engaged in activities related to the recycling of EPS foam. The EURAR and Australian risk assessment did not assess dermal exposures during this exposure scenario, with both reports stating that these exposures are expected to be low because HBCD is incorporated into the foam matrix, thus is not readily available for exposure ([NICNAS 2012b](#); [ECHA 2008b](#)). The potential dermal exposure from handling EPS and XPS foams containing HBCD is low due to the small weight fraction of HBCD in the foam and because HBCD is incorporated into the foam matrix, thus is not readily available for exposure ([NICNAS 2012b](#); [ECHA 2008b](#)). EPA does not expect dermal exposures to HBCD during this exposure scenario due to the same considerations.

Strengths, Limitations, and Confidence in Assessment Results

EPA has low to medium confidence in the assessed inhalation exposure concentrations presented above. EPA considered the quality of the data, the assessment approach, and uncertainties in assessment results to determine the level of confidence.

The result of EPA's systematic review is inhalation exposure monitoring data with an overall confidence rating of high which is a strength of the assessment. The strength of the assessment approach is the estimation of inhalation exposure concentrations to be equal to surrogate occupational inhalation exposure concentration monitoring data.

The limitation of the assessment approach is that the worker monitoring data that are the basis of the estimated inhalation exposure concentrations are not the preferred type because the type of sampling (personal breathing zone or area monitoring) is not reported for this data.

The uncertainty in the estimated HBCD potential inhalation exposure concentrations are as follows. First, as discussed Section 2.4.1.4, most of the worker monitoring data that are the basis of the estimated inhalation exposure concentrations are non-detects (specifically, three or fewer of the total of nine samples are non-detects.) Second, there is uncertainty about the extent to which the surrogate inhalation exposure concentration monitoring data are valid surrogate data because EPA is uncertain that the secondary processing of XPS foam and the recycling of EPS foam are equivalent in terms of worker exposure. Third, the extent to which the estimated occupational inhalation exposure concentration data, which are data that pertain to workers in Europe, represent the distribution of inhalation exposure air concentrations pertaining to workers in the U.S. is uncertain. Refer to Section 2.4.1.14 for additional discussion of uncertainty. Based on these strengths, limitation, and uncertainties, EPA has low to medium confidence in the assessed occupational inhalation exposure air concentrations.

2.4.1.12 Formulation of Flux/Solder Pastes

EPA lacks information about the physical form and concentration of the HBCD received at the flux/solder paste formulation site and assumed the HBCD is received as a solid either in pure form in formulations containing nearly 100% HBCD. Workers at the formulation site will likely unload HBCD into mixing equipment, where the HBCD is mixed with other ingredients and becomes suspended in the solder flux component formulation. This HBCD transfer may result in worker inhalation exposure to HBCD dust and dermal exposure to solid HBCD. Additionally, the generated dust from these transfer activities may result in ONU inhalation exposure to the HBCD dust and ONU dermal exposure through contact with surfaces where HBCD dust has settled.

Workers may also be potentially exposed from occasional cleaning of process equipment and loading of formulations into containers to be shipped to China for final formulation of the flux/solder paste. However, the unloading of HBCD powder is expected to present the highest potential exposure to HBCD, as HBCD is at the highest concentration during this activity.

Number of Potentially Exposed Workers and Occupational Non-Users

As discussed in Section 2.2.13, EPA estimated exposures for workers at one solder flux component formulation site.

The number of workers and ONUs potentially exposed during this exposure scenario was estimated using BLS data for the NAICS code 325998, All Other Miscellaneous Chemical Product and Preparation Manufacturing. These data are summarized in Table 2-78 below. Based on these data, EPA estimated that a total of 14 workers and 5 ONUs are potentially exposed during this exposure scenario.

Table 2-78. U.S. Number of Establishments and Employees for Formulation of Solder Flux

Scenario	2016 NAICS	2016 NAICS Title	Number of Establishments	Number of Workers per Site ^a	Number of ONUs per Site ^a
Formulation of flux and solder	325998	All Other Miscellaneous Chemical Product and Preparation Manufacturing	1	14	5

^a Rounded to the nearest whole number.

Inhalation Exposure Assessment

EPA estimated HBCD potential inhalation exposure concentrations to be equal to the assessed exposure concentrations reported in the EURAR ([ECHA 2008b](#)) that pertain to all polymer processing operations involving standard grade HBCD. These assessed exposure concentrations of the EURAR are based on HBCD occupational inhalation exposure concentrations that pertain to the manufacture of EPS resin beads. EPA determined these data are surrogate data because these data pertain to the worker activity of manual addition of HBCD to process equipment. EPA estimated high-end and central tendency exposure concentrations to be equal to, respectively, the “reasonable worst-case” exposure concentration of the EURAR which is equal to 2.5 mg/m³ and the “typical” exposure concentration of the EURAR which is equal to one half of the reasonable worst-case, or 1.25 mg/m³. Refer to Section 2.4.1.3, Compounding of Polystyrene Resin to Produce XPS Masterbatch, for a discussion of EPA’s approach to the estimation of these estimates of exposure concentration.

As discussed in Section 2.2.12, EPA estimated days of release at a formulation site as a range from 5 to 300 days/year. EPA expects this range of release days is also reflective of the operating days during which HBCD is processed at a formulation site and workers are potentially exposed to HBCD. However, EPA does not expect that workers will be exposed greater than 250 day/year, accounting for a worker schedule of five days per week and 50 weeks per year. Based on this information, EPA estimated worker exposures over the exposure frequency of 5 to 250 days/year. EPA used the midpoint of this range of exposure frequency, rounded up where the midpoint resulted in fractions of days, to calculate central tendency average daily dose. EPA used the high-end of this range of exposure frequency to calculate high-end average daily dose. Additionally, EPA estimated worker exposure over the full working day, or eight hours/day, as the data used to estimate inhalation exposures is 8-hour TWA data.

Dermal Exposure Assessment

As described in Section 2.4.1.1, EPA calculated dermal exposure assuming two-hand contact to solids containing 100% HBCD. EPA used this weight fraction because workers have the highest potential dermal exposure concentration to HBCD during the unloading of HBCD powder, prior to formulation. EPA calculated the potential dose for a worker to be 3,100 mg HBCD/day (high-end) and 900 mg HBCD/day (central tendency). The EURAR did not estimate dermal exposures during this exposure scenario. The NICNAS report did use EASE to model dermal exposure during the addition and weighing of HBCD into processes, which is covered in this exposure scenario. The NICNAS report estimated a dermal dose rate of 0.1 to 1 mg/cm²-day. This results in a dose of 107 to 1,070 mg/day, using EPA’s two-hand surface area of 1,070 cm² ([NICNAS 2012b](#); [ECHA 2008b](#)).

Strengths, Limitations, and Confidence in Assessment Results

EPA has medium confidence in the assessed inhalation exposure concentrations presented above. EPA considered the quality of the data, the assessment approach, and uncertainties in assessment results to

determine the level of confidence.

The result of EPA's systematic review is inhalation exposure monitoring data with an overall confidence rating of high which is a strength of the assessment. The strength of the assessment approach is the estimation of inhalation exposure concentrations based on surrogate HBCD inhalation exposure concentration monitoring data that are the preferred type of monitoring data (*i.e.*, 8-hr TWA personal breathing zone data).

There is uncertainty about the physical form and concentration of the HBCD that is received at the formulation site and hence there is uncertainty about the extent to which the surrogate data is relevant to the exposure scenario. Also, there is uncertainty in the estimated HBCD potential inhalation exposure concentrations because the bases of these concentrations are data that pertain to workers in Europe and the extent to which these concentrations represent the distribution of inhalation exposure air concentrations pertaining to workers in the U.S. is uncertain. Refer to Section 2.4.1.14 for additional discussion of uncertainty. Based on these strengths, limitation, and uncertainty, EPA has medium confidence in the assessed occupational inhalation exposure air concentrations.

2.4.1.13 Use of Flux/Solder Paste

The technical data sheets for the flux and solder products identified indicates that these formulations are frequently supplied in small containers, such as syringes and 100-gram jugs ([Indium Corporation, 2019b](#)). Workers may be potentially exposed during unloading into application equipment.

Number of Potentially Exposed Workers and Occupational Non-Users

EPA estimated exposures for workers at 227 sites based on the information in Section 2.2.13. For this estimate, EPA utilized workers and ONU estimates determined from an analysis of BLS data for the NAICS code 334400, Semiconductor and Other Electronic Component Manufacturing. These data indicate that there are, on average, 30 workers and 37 ONUs per site within NAICS code 334400. Based on these data and 227 sites, EPA estimated that a total of 6,800 workers and 6,100 ONUs are potentially exposed during this life cycle stage. EPA used unrounded figures for the number of workers and ONUs per site to calculate these totals, resulting in the slight discrepancy.

Inhalation

During this exposure scenario HBCD is in paste form within the flux/solder paste and is not available for particulate generation and exposure. Additionally, based on the process description, EPA does not expect the use of flux/solder pastes to generate mists, other particulates, or vapors, due to the low volatility of HBCD. The EURAR and NICNAS RAR indicate that HBCD begins to thermally degrade at temperatures around 190 °C ([NICNAS 2012b](#); [ECHA 2008b](#)). Typical soldering formulations start to melt between 183-188 °C, with soldering temperatures set between 30°C to 50°C higher than the liquid temperature of the alloy as a rule of thumb and expected to be set up to 300°C ([Indium Corporation 2019a, b](#)). EPA expects that the soldering process will destroy (via thermal degradation) the HBCD, making it unavailable for exposure. Based on this description, EPA does not expect worker inhalation exposure to HBCD during this exposure scenario.

Dermal

As described in Section 2.4.1.1. EPA used this model because the amount of dermal contact that workers are potentially exposed to is likely smaller than that estimated in the other exposure scenarios. This model uses a smaller quantity of solids on hands to estimate potential dose, based on worker contact with container surfaces. EPA calculated dermal exposure assuming two-hand contact to solids containing 1% HBCD. EPA calculated the potential dose for a worker to be 11.0 mg HBCD/day (high-

end) and 4.5 mg HBCD/day (central tendency). The EURAR and NICNAS did not estimate dermal exposures during this exposure scenario ([NICNAS 2012b](#); [ECHA 2008b](#)).

Strengths, Limitations, and Confidence in Assessment Results

EPA did not assess occupational inhalation exposures during this exposure scenario based on literature and industry information indicating that the temperatures at which soldering occurs are likely to result in the degradation of HBCD, as discussed above.

2.4.1.14 Recycling of Electronics Waste (E-Waste) Containing HIPS

HIPS is used in electronics such as household appliances, television sets, computers, phones, and other electronic products ([Morf et al. 2005](#)). At the end of their life, electronics may be disposed of and recycled at electronics recycling facilities. At electronics recycling facilities, workers may manually disassemble electronics, sort electronic components, and operate equipment used to further process electronic components, such as through crushing, grinding, and separation of materials (e.g., metal scrap, plastics) ([Rosenberg et al. 2011](#); [Morf et al. 2005](#)). These activities may generate dust that contains HBCD that workers and ONUs may inhale ([Rosenberg et al. 2011](#)) or come into dermal contact with once the dust settles on surfaces and workers or ONUs touch these surfaces ([Zeng et al. 2016](#); [Rosenberg et al. 2011](#)). EPA assessed potential worker exposure to the dust that is generated during electronics recycling.

Number of Potentially Exposed Workers and Occupational Non-Users

EPA estimates that there are 745 electronics recycling sites currently in the US, including both certified and uncertified sites, according to the two accredited certification programs e-Stewards and R2 ([e-Steward 2020](#); [Sustainable Electronics Recycling 2020](#)). BLS data for the NAICS code 562920, Materials Recovery Facilities, indicate that there are, on average, two workers and two ONUs per site within NAICS code 562920. However, Rosenberg et al. ([2011](#)) collected personal breathing zone samples at four waste electrical and electronic equipment recycling sites, sampling between four and seven workers per site. Therefore, the BLS data may underestimate the number of workers, so EPA assessed seven workers per site. Because the BLS data indicate a similar number of workers and ONU at these sites, EPA also assessed seven ONUs per site. This results in a total of 14 workers and ONUs per site, which is similar to the average number of total employees per establishment for NAICS code 562920 (15 employees per site, of which workers and ONUs are a component).

Based on these data and 745 sites for electronics recycling, EPA estimated that a total of 5,215 workers and 5,215 ONUs are potentially exposed in this exposure scenario.

Inhalation Exposure Assessment

EPA estimated HBCD potential inhalation exposure concentrations during electronics recycling using inhalation monitoring data from Rosenberg et al. ([2011](#)). EPA selected the data of Rosenberg et al ([2011](#)) because the overall confidence rating determined through EPA's systematic review of these data is high and no other relevant HBCD monitoring were found for this exposure scenario.

Rosenberg et al. ([2011](#)) collected personal breathing zone samples for flame retardants, including HBCD, at four waste electrical and electronic equipment (WEEE) recycling sites in Finland. Worker activities at these sites included manual disassembly and sorting of WEEE, removal of hazardous and valuable components, and operation of mechanical size reduction equipment, such as crushing and grinding machinery ([Rosenberg et al. 2011](#)). These activities are consistent with the worker activities EPA assumes to have exposure potential.

Rosenberg et al. (2011) took PBZ samples during two sampling events at each site, one before and one after the implementation of improved engineering controls, including improved ventilation, maintenance, and cleaning habits. A total of 45 PBZ samples were taken from 34 workers at the four sites during one work shift, with 24 samples taken before engineering control improvements and 21 samples taken after engineering control improvements. The results of the sampling were summarized in the supplemental file to Rosenberg et al (2011) by presenting the arithmetic mean, median, and range for each site, before and after engineering controls were implemented. Individual sampling points were not provided. Rosenberg et al (2011) does not provide individual sample times but indicates that the samples were taken over a shift with sample times ranging from 191 to 408 minutes. EPA assumes that the authors translated the individual sample results to a common time basis in order to calculate the presented summary statistics, with the time basis most likely 8 hours based on the longest sampling time of 408 minutes. Therefore, EPA assumes the data from Rosenberg et al (2011) are 8-hour TWA values.

EPA included the results from Rosenberg et al (2011) in Table 2-79 below. For this assessment, EPA only used the data taken before the implementation of engineering controls to provide a conservative assessment. As discussed in Section 2.4.1.1, EPA prefers the use of median over mean to estimate central tendency. Therefore, to estimate central tendency exposure concentration, EPA took the average of the median values presented for the four sites before the implementation of engineering controls, resulting in a central tendency value of 13.9 ng/m³, which is 0.0000139 mg/m³. To estimate high-end exposure concentration, EPA used the maximum of all the ranges presented for the four sites before the implementation of engineering controls, resulting in a high-end value of 100 ng/m³, which is 0.0001 mg/m³. As discussed in Section 4.2.2, EPA determined that the MOE values for these inhalation exposure concentrations were all above the benchmark values; therefore, EPA did not further refine the central tendency and high-end inhalation exposure concentrations to account for the monitoring data taken after the implementation of engineering controls.

EPA did not find data on the exposure frequency of this exposure scenario. EPA assessed the maximum number of exposure days to be 250 days/year, based on a work schedule of five days per week and 50 weeks per year. EPA used this value to calculate high-end average daily dose. EPA used the midpoint of the range of 1 to 250 days/year of exposure frequency, rounded up to 126 days/year, to calculate central tendency average daily dose. Additionally, EPA estimated worker exposure over the full working day, or eight hours/day, as the data used to estimate inhalation exposures are 8-hour TWA data.

Table 2-79. Inhalation Monitoring Data for HBCD at Electronics Recycling Sites

Data Source/Study ^a	Exposure Scenario	Form of HBCD Handled	Type of Sample	Worker Activity or Sampling Location	Exposure Concentration (ng/m ³) ^b	Number of Samples	Sample Time / Type of Measurement	Source	Overall Confidence Rating
Inhalation Monitoring Data Used in this Assessment to Estimate Worker Exposures Resulting from Electronics Recycling									
Rosenberg et al (2011) – 1a	WEEE Recycling – before engineering controls	HBCD dust	Personal Breathing Zone	Site A - Sorting, disassembly, process controllers (for mechanical separations)	Range: 13 – 47 Mean: 29 Median: 27 ng/m ³	6	8-hr TWA	(Rosenberg et al. 2011)	High
Rosenberg et al (2011) – 1b	WEEE Recycling – before engineering controls	HBCD dust	Personal Breathing Zone	Site B - Sorting, disassembly, process controllers (for mechanical separations)	Range: 5.7 – 100 Mean: 38 Median: 15 ng/m ³	7	8-hr TWA	(Rosenberg et al. 2011)	High
Rosenberg et al (2011) – 1c	WEEE Recycling – before engineering controls	HBCD dust	Personal Breathing Zone	Site C - Sorting, disassembly, process controllers (for mechanical separations)	Range: 4.9 – 8.0 Mean: 6.5 Median: 6.4 ng/m ³	5	8-hr TWA	(Rosenberg et al. 2011)	High
Rosenberg et al (2011) – 1d	WEEE Recycling – before engineering controls	HBCD dust	Personal Breathing Zone	Site D - Sorting, disassembly, process controllers (for mechanical separations)	Range: 4.5 – 8.5 Mean: 6.6 Median: 7.2 ng/m ³	6	8-hr TWA	(Rosenberg et al. 2011)	High
Other Inhalation Monitoring Data Not Used in this Assessment									
Rosenberg et al (2011) – 2a	WEEE Recycling – after engineering controls are	HBCD dust	Personal Breathing Zone	Site A - Sorting, disassembly, process	Range: ND – 8.5 Mean: 2.9	6	8-hr TWA	(Rosenberg et al. 2011)	High

Data Source/Study ^a	Exposure Scenario	Form of HBCD Handled	Type of Sample	Worker Activity or Sampling Location	Exposure Concentration (ng/m ³) ^b	Number of Samples	Sample Time / Type of Measurement	Source	Overall Confidence Rating
	implemented/ improved			controllers (for mechanical separations)	Median: 1.3 ng/m ³				
Rosenberg et al (2011) – 2b	WEEE Recycling – after engineering controls are implemented/ improved	HBCD dust	Personal Breathing Zone	Site B - Sorting, disassembly, process controllers (for mechanical separations)	Range: 0.90 – 88 Mean: 23 Median: 3.5 ng/m ³	5	8-hr TWA	(Rosenberg et al. 2011)	High
Rosenberg et al (2011) – 2c	WEEE Recycling – after engineering controls are implemented/ improved	HBCD dust	Personal Breathing Zone	Site C - Sorting, disassembly, process controllers (for mechanical separations)	Range: ND Mean: ND Median: ND	4	8-hr TWA	(Rosenberg et al. 2011)	High
Rosenberg et al (2011) – 2d	WEEE Recycling – after engineering controls are implemented/ improved	HBCD dust	Personal Breathing Zone	Site D - Sorting, disassembly, process controllers (for mechanical separations)	Range: ND Mean: ND Median: ND	6	8-hr TWA	(Rosenberg et al. 2011)	High

ND = Non-detect for HBCD.

a – Where multiple datasets were available from one literature source, EPA distinguished data as 1a, 1b, 2a, 2b, etc.

b – The statistical values were obtained from the referenced literature source and were not calculated by EPA.

Dermal Exposure Assessment

The potential dermal exposure from handling HIPS containing HBCD is low due to the small weight fraction of HBCD in the HIPS and because HBCD is incorporated into the polymer matrix ([ECHA 2009c](#)). However, dust containing HBCD may be generated during electronics recycling. Workers and ONUs may come into dermal contact with HBCD in these dusts when the dust settles on surfaces and workers or ONUs touch these surfaces ([Zeng et al. 2016](#); [Rosenberg et al. 2011](#)).

Therefore, EPA assessed worker dermal exposure to dusts containing HBCD at electronics recycling sites. As described in Section 2.4.1.1, EPA used the *EPA/OPPT Direct 2-Hand Dermal Contact with Solids Model* ([U.S. EPA 2013a](#)) and Marquart et al. ([2006](#)) to estimate high-end and central tendency worker dermal potential dose rate. These sources estimate potential dose rates of 3,100 mg/day (high-end) and 900 mg/day (central tendency) for quantity of solids retained on a worker's skin. These quantities do not pertain to dermal exposure to settled dust and are used here as conservative estimates. To estimate the quantity of HBCD in solids, EPA used data on the concentration of HBCD in dust on the floors at electronics recycling sites from Zeng et al. ([2016](#)). EPA used the data from Zeng et al. ([2016](#)) because no other relevant data were found. The overall confidence rating determined through EPA's systematic review of these data is medium.

Zeng et al. ([2016](#)) collected 48 samples of surface particulates from the floors of four major electronics waste recycling sites in China. These samples were analyzed for multiple compounds, including HBCD. Zeng et al. ([2016](#)) reported HBCD concentrations in these samples by providing the range and average for the samples taken at each of the four sites. EPA used the maximum HBCD concentration from Zeng et al. ([2016](#)), which is 57,000 ng HBCD/g dust equaling an HBCD fraction of 0.000057, to estimate dermal exposures. EPA calculated the potential dose rate for a worker to be a high-end of 0.18 mg HBCD/day (3,100 mg solids/day x 0.000057) and a central tendency of 0.051 mg HBCD/day (900 mg solids/day x 0.000057). As discussed in Section 4.2.2.5, EPA determined that the MOE values for these dermal exposure estimates were all above the benchmark values; therefore, EPA did not further refine the dermal exposure estimates to account for the average HBCD concentrations presented in Zeng et al. ([2016](#)) or a lower solids potential dose rate.

Strengths, Limitations, and Confidence in Assessment Results

EPA has medium confidence in the assessed inhalation exposure concentrations presented above. EPA considered the quality of the data, the assessment approach, and uncertainties in assessment results to determine the level of confidence.

The result of EPA's systematic review is inhalation exposure monitoring data with an overall confidence rating of high, which is a strength of the assessment. The strength of the assessment approach is the use of inhalation exposure monitoring data that (a) are the preferred type of monitoring data (*i.e.*, 8-hr TWA personal breathing zone data), (b) are directly applicable to this exposure scenario, and (c) comprise data from multiple sites and workers.

The limitation of the assessment approach is the estimation of inhalation exposure concentrations based on averaging the median values and using the maximum of the available monitoring data because individual sampling points were not available. However, EPA did not refine this approach because all calculated MOE values were above the benchmark. In addition, the assessment is limited because only one relevant dataset from the literature was available.

There is uncertainty in the estimated HBCD potential inhalation exposure concentrations because these concentrations pertain to workers in Europe and the extent to which these concentrations represent the

distribution of inhalation exposure air concentrations pertaining to workers in the U.S. is uncertain. Refer to Section 2.4.1.14 for additional discussion of uncertainty. Based on these strengths, limitation, and uncertainty, EPA has medium confidence in the assessed occupational inhalation exposure air concentrations.

2.4.1.15 Assumptions and Key Sources of Uncertainties for Occupational Exposures

Uncertainty is “the lack of knowledge about specific variables, parameters, models, or other factors” and can be described qualitatively or quantitatively. The following sections discuss uncertainties throughout the assessed HBCD exposure scenario scenarios.

2.4.1.15.1 Number of Workers

There are a number of uncertainties surrounding the estimated number of workers potentially exposed to HBCD, as outlined below.

First, BLS occupational employment statistics employment data for each industry/occupation combination are only available at the 3-, 4-, or 5-digit NAICS level, rather than the full 6-digit NAICS level. This lack of granularity could result in an overestimate of the number of exposed workers if some 6-digit NAICS are included in the less granular BLS estimates but are not, in reality, likely to use HBCD for the assessed applications. EPA addressed this issue by refining the occupational employment statistics estimates using total employment data from the U.S. Census SUSB. However, this approach assumes that the distribution of occupation types (SOC codes) in each 6-digit NAICS is equal to the distribution of occupation types at the parent 5-digit NAICS level. If the distribution of workers in occupations with HBCD exposure differs from the overall distribution of workers in each NAICS, then this approach may result in inaccuracy, resulting in either an overestimation or underestimation of the number of potentially exposed workers.

Second, EPA’s judgments about which industries (represented by NAICS codes) and occupations (represented by SOC codes) are associated with the uses assessed in this assessment are based on EPA’s understanding of how HBCD is used in each industry. Designations of which industries and occupations have potential exposures is nevertheless subjective, and some industries/occupations with few exposures might erroneously be included, or some industries/occupations with exposures might erroneously be excluded. This would result in inaccuracy and could either overestimate or underestimate the estimate of exposed workers.

2.4.1.15.2 Estimation of Inhalation Exposure Concentration and Average Daily Dose

For the most part, EPA estimated HBCD potential inhalation exposure concentrations to be equal to surrogate HBCD inhalation exposure concentration monitoring data. There is uncertainty about the extent to which these monitoring data are valid surrogate data. A reason for this is that there is uncertainty about whether the process equipment and/or worker activities associated with the monitoring data are comparable to the corresponding process equipment and/or worker activities pertaining to the exposure scenarios that EPA assessed. Even if the process equipment and/or the worker activities were comparable, there would still be uncertainty because for the most part EPA estimated HBCD potential inhalation exposure concentrations to be equal to HBCD inhalation exposure concentration monitoring data pertaining to workers at sites in Europe.

The extent to which HBCD inhalation exposure concentration monitoring data pertaining to workers at sites in Europe represent the distribution of inhalation exposure air concentrations pertaining to workers in the U.S. is uncertain because the determinants of HBCD occupational exposure in Europe and in the

U.S. may not be similar. These determinants include the engineering controls. The engineering controls in Europe and in the U.S. may be different due to differing occupational exposure limits. For example, the occupational exposure limit (OEL) for organic dust and mist in Sweden, which may be applicable to HBCD, is 5 mg/m³ ([ECHA, 2008b](#)) but an OEL for HBCD is not established in the U.S. and the OSHA PEL is 15 mg/m³.

EPA calculated average daily dose (ADD) for use in risk characterization assuming an exposure frequency equal to the midpoint and high-end of the range of operating days per year, as discussed for each exposure scenario. Use of the high-end exposure days assumes the workers are exposed every working day, which may be an overestimate if workers do not conduct the worker activities that are associated with the assessed exposure scenarios during each day of operation.

2.4.1.15.3 Modeling Dermal Exposures

To model dermal exposures, EPA used the *EPA/OPPT Direct 2-Hand Dermal Contact with Solids Model*, *EPA/OPPT Direct 2-Hand Dermal Contact with Container Surfaces (Solids) Model* and the typical exposure data reported in ([Marquart, 2006](#)) to estimate high-end and central tendency exposure estimates. These estimates do not account for the potential exposure reduction due to glove use. In addition, the potential dermal exposure estimates do not account for variations in the particle sizes of the solid, amount being handled, or duration of worker activity performed. EPA modeled dermal exposures using an upper-end estimate of 6.5% steady-state absorption (see Section 3.2.2). Absorption in occupational settings may be lower than this value based on frequent hand washing or uneven distribution across skin.

2.4.1.15.4 Occupational Non-User (ONU) Potential Inhalation Exposure

As discussed in Section 2.4.1.1, Occupational Exposures Approach and Methodology, EPA assumes ONU potential HBCD inhalation exposure levels to be lower than those of workers. During the construction and demolition of buildings, EPA believes that ONUs may work in close proximity to workers and hence may be exposed to HBCD air concentrations similarly to workers. Furthermore, the duration and frequency of the ONUs' work during the construction and demolition of buildings may equal that of the workers at least for limited periods of time. That is, trade workers such as electricians and plumbers may work in close proximity to workers installing XPS/EPS insulation containing HBCD for the duration of a particular construction project but that is not necessarily always the case. In conclusion, there is uncertainty about whether the HBCD potential exposure level of ONUs in the case of construction and demolition workers is lower than those of workers.

2.4.1.15.5 Firefighter Potential Occupational Exposure

Firefighters represent a subset of the worker population that could be exposed to HBCD from the burning of building materials and other products. The exposure of HBCD could stem from multiple conditions of use (*e.g.*, building materials, automobile parts, and other plastics). For the HBCD Problem Formulation, EPA did not include firefighters within the lifecycle diagram or conceptual model as an assessment that EPA would include in this risk evaluation. However, EPA acknowledges that firefighters may be exposed to HBCD and its thermal degradants via inhalation and dermal route.

EPA has identified limited information on firefighter exposure specific to HBCD. A review of literature in general for firefighters did indicate firefighters may be exposed to flame retardants and combustion by-products during firefighting, overhaul (searching for fire extending into building spaces), or through contact with contaminated clothing and equipment and dust at firehouses ([Minnesota Department of Health, 2016](#)). Firefighters generally wear SCBA, gloves, hoods, and coats as protective gear ([Mayer et al., 2019](#); [Alexander and Baxter, 2016](#); [Fent et al., 2015](#)). However, firefighters do not always wear

SCBA during exterior operations (deploying hoses, forcible entry) or during overhaul operations, and even has been found to still be exposed to particulates and vapors to the neck and hands with PPE (Fent et al., 2015). Multiple sources indicate that flame retardants can accumulate on PPE over time (Mayer et al., 2019; Alexander and Baxter, 2016; Horn et al., 2016; Fent et al., 2015) and then transfer to the skin of firefighters during activities such as turnout and cleaning. Alexander et al. (2016), Mayer et al. (2019), and Horn et al. (2016) all sampled for and detected PBDEs, non-PBDE flame retardant and organophosphate flame retardants on used firefighter PPE. Only Mayer et al. (2019) specifically sampled for HBCD (on firefighter hoods), which was not detected in any hoods. This study was the only information EPA identified that specifically looked at HBCD, EPA identified additional studies that investigated other flame retardants including other brominated flame retardants (e.g., PBDEs, TBBPA).

Horn et al. (2016) measured area air concentrations of flame retardants including PBDEs and multiple other flame retardants (not including HBCD) during a controlled active residential fire and overhaul, detecting nine of the eighteen sampled flame retardants during the controlled fire (ranging from 1.2 to 2000 $\mu\text{g}/\text{m}^3$) and two flame retardants during overhaul (1.9 and 14 $\mu\text{g}/\text{m}^3$). Fent et al. (2018) measured various chemical concentrations including hydrogen bromide in ten area samples that ranged from non-detect to 19.8 mg/m^3 . NICNAS indicates that the combustion of brominated flame retardants can be a source of hydrogen bromide (NICNAS, 2012b). EPA found one source that measured the concentration of flame retardants in dust at fire stations (Shen et al., 2018). Shen et al. (2018) did not sample for HBCD, but did conclude that fire stations are contaminated with higher levels of flame retardants than residences and other occupational settings.

Shaw et al. (2013) measured PBDEs and polybrominated dibenzo-p-dioxins and dibenzofurans (PBDDFs) in the serum of 12 firefighters. This study notes that PBDDFs are produced during the combustion of wastes containing brominated flame retardants (Shaw et al., 2013). Shaw et al. (2013) found that levels of PBDEs in firefighters were higher than those detected in the general U.S. population, concluding that the results are suggestive of significant occupational exposure to these compounds during firefighting. Shaw et al. (2013) indicates that, while preliminary, the serum concentrations of PBDDFs in firefighters suggest that occupational exposure to PBDDFs formed during fires may be significant for firefighters.

In summary, EPA believes firefighters may be exposed to flame retardants, which may include HBCD. However, EPA did not quantify these exposures as EPA lacks data specific to HBCD on these exposures and exposures of other flame retardants are not easily translated to HBCD due to differences in chemical properties, volumes, and uses. The potential exposures faced by firefighters is a source of uncertainty in the occupational exposure assessment.

2.4.1.15.6 Summary of Occupational Exposures

For the risk characterization of occupational exposures, EPA used the 8-hour TWA exposure concentrations (both central tendency and high-end values) that EPA selected for each exposure scenario (refer to Sections 2.4.1.2 through 2.4.1.13 for rationale for these selections). Specifically, EPA used these exposure concentration values to calculate acute exposure dose (AED) and acute daily dose (ADD), which were then multiplied by the inhalation absorption factor of 100% (discussed in Section 3.2.2) to estimate the acute absorbed dose (AAD) and chronic absorbed dose (CAD), respectively. Similarly, for dermal exposures, EPA used the potential dermal dose rates (refer to Sections 2.4.1.2 through 2.4.1.13 for rationale for EPA's determination of these values) to calculate AED and ADD, then multiplied these values by a dermal absorption factor of 6.5% (discussed later in Section 3.2.2) to estimate the AAD and CAD. Additional explanation of these equations and example calculations are located in Appendix E.3 and Appendix E.4, respectively.

A summary of the 8-hour TWA or dermal dose rate, AAD, and CAD values used in this Risk Evaluation is presented in Table 2-80 and Table 2-81 below. The ADD and CAD are used to characterize chronic, non-cancer risks in Section 4.2.

Table 2-80. Acute and Chronic Inhalation Exposure Estimates, Worker Occupational Scenarios ^a

Occupational Scenario – Inhalation Exposure	Eight-Hour TWA Exposures		Acute Absorbed Dose		Chronic Absorbed Dose		Characterization
	C _{HBCD} , 8-hr TWA (mg/m ³)		AAD _{HBCD} (mg/kg-day)		CAD _{HBCD} (mg/kg-day)		
	High-End	Central Tendency	High-End	Central Tendency	High-End	Central Tendency	
Repackaging of import containers	1.9E+00	8.9E-01	2.4E-01	1.1E-01	1.6E-01	4.27E-02	High-end: 90th percentile Central Tendency: Median
Compounding of Polystyrene Resin to Produce XPS Masterbatch	2.5E+00	1.3E+00	3.1E-01	1.6E-01	5.1E-02	1.50E-02	High-end: Reasonable ‘worst-case’ from EURAR Central Tendency: Typical from EURAR
Processing to Produce XPS Foam Using XPS Masterbatch	2.2E-01	8.0E-02	2.8E-02	1.0E-02	1.2E-03	2.47E-04	High-end: 90th percentile Central Tendency: Mean
Processing of HBCD to Produce XPS Foam	2.5E+00	1.3E+00	3.1E-01	1.6E-01	1.4E-02	3.85E-03	High-end: Reasonable ‘worst-case’ from EURAR Central Tendency: Typical from EURAR
Processing to Produce EPS Foam Using Imported EPS Resin Beads	2.2E-01	8.0E-02	2.8E-02	1.0E-02	1.1E-02	2.14E-03	High-end: 90th percentile Central Tendency: Mean
Processing to Produce SIPs and Automobile Replacement Parts from XPS/EPS Foam	2.2E-01	8.0E-02	2.8E-02	1.0E-02	1.9E-02	3.64E-03	High-end: 90th percentile Central Tendency: Mean
Use: Installation of Automobile Replacement Parts ^b	--	--	--	--	--	--	
Use: Installation of XPS/EPS Foam Insulation in Residential, Public and Commercial Buildings, and Other Structures	2.2E-01	8.0E-02	2.8E-02	1.0E-02	1.9E-02	3.45E-03	High-end: 90th percentile Central Tendency: Mean
Demolition and Disposal of XPS/EPS Foam Insulation in Residential, Public and Commercial Buildings, and Other Structures	3.0E-01	1.1E-01	3.8E-02	1.3E-02	2.6E-02	4.53E-03	This is a range using the OSHA PNOR PEL of 15 mg/m ³ and HBCD concentration of 0.7% in EPS and 2% in XPS.

Occupational Scenario – Inhalation Exposure	Eight-Hour TWA Exposures		Acute Absorbed Dose		Chronic Absorbed Dose		Characterization
	C _{HBCD} , 8-hr TWA (mg/m ³)		AAD _{HBCD} (mg/kg-day)		CAD _{HBCD} (mg/kg-day)		
	High-End	Central Tendency	High-End	Central Tendency	High-End	Central Tendency	
Processing: Recycling of EPS Foam	2.2E-01	8.0E-02	2.8E-02	1.0E-02	1.1E-02	1.95E-03	High-end: 90th percentile Central Tendency: Mean
Formulation of Flux / Solder Paste	2.5E+00	1.3E+00	3.1E-01	1.6E-01	2.1E-01	5.48E-02	High-end: Reasonable ‘worst-case’ from EURAR Central Tendency: Typical from EURAR
Use of Flux / Solder Paste^b	--	--	--	--	--	--	
Recycling of Electronics Waste (E-Waste) Containing HIPS	1.0E-04	1.4E.05	1.3E-05	1.7E-06	8.6E-06	6.1E.07	High-end: High-end of range Central Tendency: Average of medians

^a As discussed in Section 2.4.1.1 EPA expects potential inhalation exposure of an Occupational Non-User (ONU) in the case of some of the exposure scenarios but EPA did not assess this exposure due to lack of data. EPA expects these exposures to be lower than the exposures of the corresponding workers. ^bEPA did not estimate inhalation exposures for these exposure scenarios as EPA does not expect the generation of dust for these exposure scenarios.

Table 2-81. Acute and Chronic Dermal Exposure Estimates, Worker Occupational Scenarios

Occupational Scenario – Dermal Exposure	Potential Dose Rate D _{exp} (mg/day)		Acute Absorbed Dose AAD _{HBCD} (mg/kg-day)		Chronic Absorbed Dose CAD _{HBCD} (mg/kg-day) ^a		Characterization
	High-End	Central Tendency	High-End	Central Tendency	High-End	Central Tendency	
Repackaging of import containers	3.1E+03	9.0E+02	2.5E+00	7.3E-01	1.7E+00	2.8E-01	Chronic absorbed dose – High-end: Maximum number of exposure days Central tendency: midpoint of exposure days
Compounding of Polystyrene Resin to Produce XPS Masterbatch	3.1E+03	9.0E+02	2.5E+00	7.3E-01	4.1E-01	7.0E-02	Chronic absorbed dose – High-end: Maximum number of exposure days Central tendency: midpoint of exposure days

Occupational Scenario – Dermal Exposure	Potential Dose Rate D_{exp} (mg/day)		Acute Absorbed Dose AAD_{HBCD} (mg/kg-day)		Chronic Absorbed Dose CAD_{HBCD} (mg/kg-day) ^a		Characterization
	High-End	Central Tendency	High-End	Central Tendency	High-End	Central Tendency	
Processing to Produce XPS Foam Using XPS Masterbatch	2.2E+03	6.3E+02	1.8E+00	5.1E-01	7.7E-02	1.3E-02	Chronic absorbed dose – High-end: Maximum number of exposure days Central tendency: midpoint of exposure days
Processing of HBCD to Produce XPS Foam	3.1E+03	9.0E+02	2.5E+00	7.3E-01	1.1E-01	1.8E-02	Chronic absorbed dose – High-end: Maximum number of exposure days Central tendency: midpoint of exposure days
Processing to Produce EPS Foam Using Imported EPS Resin Beads	--	--	--	--	--	--	
Processing to Produce SIPs and Automobile Replacement Parts from XPS/EPS Foam	--	--	--	--	--	--	
Use: Installation of Automobile Replacement Parts	--	--	--	--	--	--	
Use: Installation of XPS/EPS Foam Insulation in Residential, Public and Commercial Buildings, and Other Structures	--	--	--	--	--	--	
Demolition and Disposal of XPS/EPS Foam Insulation in Residential, Public and Commercial Buildings, and Other Structures	--	--	--	--	--	--	
Processing: Recycling of EPS Foam	--	--	--	--	--	--	
Formulation of Flux / Solder Paste	3.1E+03	9.0E+02	2.5E+00	7.3E-01	1.7E+00	2.6E-01	Chronic absorbed dose – High-end: Maximum number of exposure days Central tendency: midpoint of exposure days
Use of Flux / Solder Paste	1.1E+01	4.5E+00	8.9E-03	3.7E-03	6.1E-03	1.0E-03	Chronic absorbed dose – High-end: Maximum number of exposure days Central tendency: midpoint of exposure days

Occupational Scenario – Dermal Exposure	Potential Dose Rate D_{exp} (mg/day)		Acute Absorbed Dose AAD_{HBCD} (mg/kg-day)		Chronic Absorbed Dose CAD_{HBCD} (mg/kg-day) ^a		Characterization
	High-End	Central Tendency	High-End	Central Tendency	High-End	Central Tendency	
Recycling of Electronics Waste (E-Waste) Containing HIPS	1.8E-01	5.1E-02	1.4E-04	4.2E-05	9.8E-05	1.5E-05	Chronic absorbed dose – High-end: Maximum number of exposure days Central tendency: midpoint of exposure days

2.4.2 General Population (Background) Exposures

2.4.2.1 General Population Exposure Approach and Methodology

HBCD is used primarily as an additive flame retardant in a variety of materials. HBCD has been detected in the indoor and outdoor environment and in human biomonitoring indicating that some amount of exposure is occurring in some individuals, although exposures likely vary across the general population. See *Risk Evaluation for Cyclic Aliphatic Bromide Cluster (HBCD), Supplemental Information on General Population, Environmental, and Consumer Exposure Assessment* or a summary of environmental and biomonitoring studies where HBCD has been detected.

The migration of additive flame retardants from indoor sources such as building materials, plastics, and other articles (from in-service products/articles at the end of their life cycle (Section 1.2.8) as well as historical releases (Section 1.2.9) resulting from HBCD's persistence in the environment) appears a likely source of flame retardants found in indoor dust, suspended particles, and indoor air (Guo 2013; Dodson et al. 2012; Weschler and Nazaroff 2010). However, the relative contribution of different sources of HBCD in these matrices is not well characterized. For example, HBCD present in building insulation, textiles, and recycled XPS and EPS materials are likely to have differing magnitudes of emissions. The totality of background exposure includes steady-state environmental exposures ongoing releases not associated with a particular COU, background/indirect exposures from minor use products (e.g., textiles, electrical and electronic products, adhesives, and coatings) (Section 1.2.8), and releases stemming from historical activities (Section 1.2.9) due to HBCD's persistence in the environment

Emission of HBCD is likely to occur through the following mechanisms: diffusion from sources and gas-phase mass-transfer, abrasion of materials to form small particulates through routine use, and direct transfer from articles to dust adhered to the article surface. Releases of flame retardants to the outdoor environment may occur through direct releases to water and air as well as indirect releases from the indoor environment. For a more detailed discussion about indoor SVOC exposure, fate and transport in the indoor environment, please see the *Risk Evaluation for Cyclic Aliphatic Bromide Cluster (HBCD), Supplemental Information on General Population, Environmental, and Consumer Exposure Assessment*.

Exposure to general population from non-scenario specific uses was estimated for emissions to water and air, as depicted in Figure 2-3.

Uses	Summary of Release Types	Summary of Media or Pathways	Exposure Scenarios	Media Estimation Methods
Non-scenario Specific	Emission to water: <ul style="list-style-type: none"> • Diet • Soil • Air Emission to air: <ul style="list-style-type: none"> • Air • Dust • Dermal 	Ambient Air, Indoor Air, Indoor Dust, Soil, Diet, Breastmilk	General Background Exposure	<u>All media</u> <ul style="list-style-type: none"> • Use monitoring data collected at sites away from manufacturing facilities • Reverse dosimetry

Figure 2-3. Overview of General Population Exposure Assessment

Figure 2-4 depicts the two approaches used by EPA to estimate exposures, both of which consider multiple pathways of exposure. First, EPA estimated exposure doses using an indirect estimation method that entailed combining environmental monitoring data (*i.e.*, HBCD concentration in dietary sources, dust, soil, ambient air, indoor air, and dermal loading) with age specific exposure factors and activity patterns. EPA also estimated exposure doses using an exposure reconstruction method that entailed combining human biomonitoring data from various environmental matrices with assumptions about lipid content and generalized one-compartment half-life in the body. There is general concordance between the two approaches. No modeling data was used for the general population receptor group.

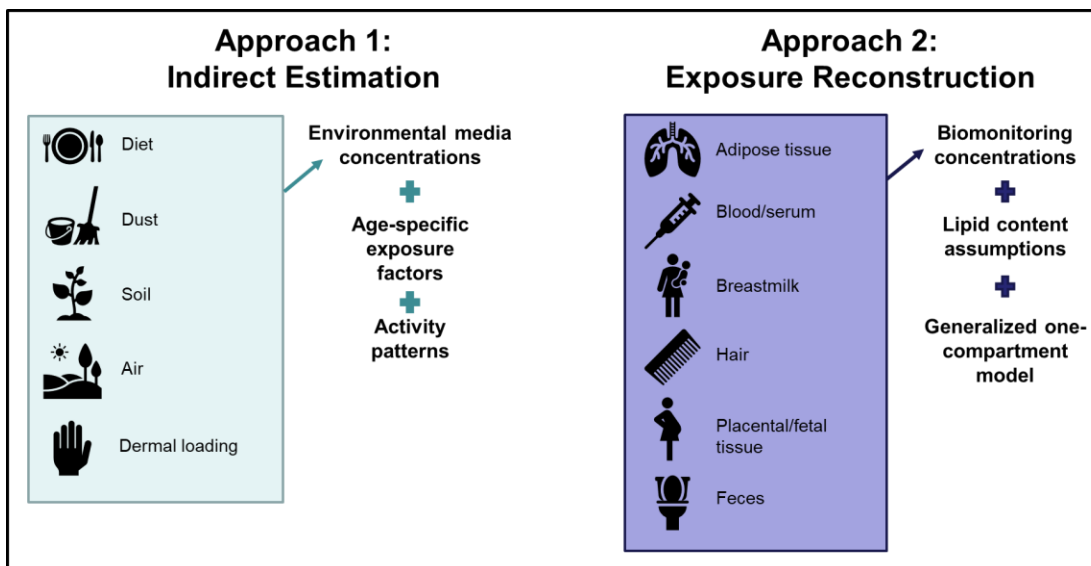

Figure 2-4. Two Exposure Assessment Approaches used to Estimate General Population Exposure to HBCD

For each exposure pathway, central tendency and high-end doses were estimated. EPA's Human Exposure Guidelines defined central tendency exposures as "an estimate of individuals in the middle of the distribution." It is anticipated that these estimates apply to most individuals in the U.S. high-end exposure estimates are defined as "plausible estimate of individual exposure for those individuals at the upper end of an exposure distribution, the intent of which is to convey an estimate of exposure in the upper range of the distribution while avoiding estimates that are beyond the true distribution." It is anticipated that these estimates apply to some individuals, particularly those who may live near facilities with elevated concentrations.

2.4.2.2 Indirect Estimation Using Environmental Monitoring Data and Exposure Factors

EPA considered the following exposure pathways for the general population using the indirect estimation approach:

- Dietary
 - a. Grains
 - b. Vegetables
 - c. Fruit
 - d. Meat
 - e. Dairy
 - f. Fats

- g. Seafood (all age groups except infants)
- h. Breast milk (for infant age group only)
- Ingestion of dust and soil
- Inhalation of particles (indoor and outdoor)
- Dermal absorption of dust, soil, and/or materials

Equations: EPA describes the equations and inputs used to estimate the exposures in Sections 2.4.2.2.1 through 2.4.2.2.5. For each pathway within the seven different age groups (ranging from infants to adults), EPA calculated a central and high-end average daily dose (ADD) and then summed the pathway specific doses to estimate aggregate doses for each age group. In this method EPA generally used central tendency monitoring data and exposure factor inputs to calculate the central tendency ADD and high-end values to calculate the high-end ADD. The calculated doses are presented in Section 2.4.2.2.5 for each pathway individually and for the aggregate of all pathways.

Exposure Factors: Body weights, intakes rates, and other exposure factors used in the equations were derived from EPA and other agency sources, in particular many were obtained from the Exposure Factors Handbook ([U.S. EPA 2011b](#)). More information on the exposure factors used in each individual media exposure assessment is presented in Appendix G.

Monitoring Data: For the indirect exposure approach, EPA screened, evaluated, and extracted monitoring data for food, air, dust, and soil data. All studies with available monitoring data and passing evaluation scores were considered for determining environmental concentrations and overall trends. The following criteria were applied to obtain a representative final dataset for each media of interest:

- **Location Type:** Data were classified as near facility (point source) or away from facility (non-point source or background) as discussed in the Environmental Exposure section. Data classified as near facility were excluded from the general population analysis.
- **Country:** Since only limited U.S. data was identified through systematic review, data from all high-income countries as classified by the World Bank (June 2019) were included in the final analysis (<https://datahelpdesk.worldbank.org/knowledgebase/articles/906519-world-bank-country-and-lending-groups>). High-income countries were selected as surrogate countries based on the assumption that these countries have manufacturing, processing, and use characteristics that are most likely to resemble those in the United States. Refer to Appendix G for a list of monitoring data availability by country and media type.
- **Unit Fraction:** Only data in accepted fractions were included (see Table 2-82). Concentrations were converted to acceptable unit fractions if conversion factors were provided in the study, including TOC to dry weight. For food, only wet weight unit fractions were used since no dry weight to weight conversion factors were available.
- **Source of Food:** For food groups, data reported from market basket studies were included and data from wild caught studies were excluded. Wild caught fish monitoring data were considered in the highly-exposed assessment.

A description of the statistical approach to estimating the central and high-end concentrations can be found in *Risk Evaluation for Cyclic Aliphatic Bromide Cluster (HBCD), Supplemental Information on*

General Population, Environmental, and Consumer Exposure Assessment. In short, EPA estimated an arithmetic mean and 90th percentile value for each dataset based on its distribution type (lognormal or normal), and from these values calculated an overall central tendency (mean of means) and high-end value (average of 90th percentile). The distribution type was determined from the type and combination of statistical parameters available in the study (*i.e.*, geometric mean, arithmetic mean, median, geometric standard deviation, standard deviation, minimum, and/or maximum). Most combinations were assigned a lognormal distribution type, unless mean estimates were outside the range of reported data. A normal distribution type was assigned to datasets with only a mean and standard deviation or when the mean and medians were the same. Datasets were excluded from the final analysis dataset when not enough parameters were available to estimate a mean or 90th percentile (*i.e.*, only a range of values or only a minimum or maximum value was reported). Table 2-82 provides a summary of the number of studies extracted and number of studies used in the final dataset, and the selected unit fraction.

Table 2-82. Summary of Monitoring Studies Identified and Used in the General Population Exposure Assessment

Media	Number of Studies Extracted	Number of Studies in Final Dataset	Fraction
Fruits	4	1 ^a	Wet
Vegetables	5	2 ^b	Wet
Grains	7	2 ^b	Wet
Meats	20	3 ^c	Wet
Dairy	14	3 ^d	Wet
Fats	9	2 ^e	Wet
Seafood	22	8 ^f	Wet
Breast milk	33	17 ^g	Lipid
Indoor Air			
Residential	8	4 ^h	Gas and/or particulate
Public and commercial buildings (PCB)	7	5 ⁱ	Gas and/or particulate
Vehicles	3	2 ^j	Gas and/or particulate
Ambient Air	20	7 ^k	Gas and/or particulate
Indoor dust			
Residential	34	24 ^l	Dry
Public and commercial building (PCB)	20	16 ^m	Dry
Vehicles	6	5 ⁿ	Dry
Soil	17	2 ^o	Dry
Handwipe	2	1 ^p	n/a

^a Fruits: ([Barghi et al. 2016](#))

- ^b Vegetables and Grains: ([Barghi et al. 2016](#); ([Fsa 2006](#))
- ^c Meat: ([Schechter et al. 2012](#)); ([Barghi et al. 2016](#); ([Fsa 2006](#))
- ^d Dairy: ([Barghi et al. 2016](#); ([Fernandes et al. 2016](#)); ([Fsa 2006](#))
- ^e Fats: ([Schechter et al. 2012](#)); ([Fsa 2006](#))
- ^f Seafood: ([Drifffield et al. 2008](#)); ([Schechter et al. 2012](#)); ([Kakimoto et al. 2012](#)); ([Ortiz et al. 2011](#)); ([Nakagawa et al. 2010](#)); ([Barghi et al. 2016](#); ([Fernandes et al. 2016](#)); ([Son et al. 2015](#))
- ^g Breastmilk: ([de Wit et al. 2012](#)); ([Abdallah and Harrad 2011](#)); ([Eggesbø et al. 2011](#)); ([Fängström et al. 2008](#)); ([Glynn et al. 2011](#)); ([Carignan et al. 2012](#)); ([Toms et al. 2012](#)); ([Roosens et al. 2010b](#)); ([Eljarrat et al. 2009](#)); ([Ryan and Rawn 2014](#)); ([Darnerud et al. 2015](#)); ([Harrad and Abdallah 2015](#)); ([Ryan et al. 2006](#)); ([Antignac et al. 2016](#)); ([Lignell et al. 2003](#)); ([Tao et al. 2017](#)); ([de Wit et al. 2012](#))
- ^h Indoor air – residential: ([de Wit et al. 2012](#)); ([Abdallah et al. 2008](#)); ([Saito et al. 2007](#)); ([Newton et al. 2015](#))
- ⁱ Indoor air – PCB: ([de Wit et al. 2012](#)); ([Abdallah et al. 2008](#)); ([Saito et al. 2007](#))
- ^j Indoor air – vehicle: ([de Wit et al. 2012](#)); ([Abdallah and Harrad 2010](#))
- ^k Ambient air: ([Hoh and Hites 2005](#)); ([Drage et al. 2016](#)); ([Abdallah et al. 2008](#)); ([Newton et al. 2015](#)); ([Vorkamp et al. 2015](#)); ([Shoeib et al. 2014](#)); ([KLIF 2010](#))
- ^l Indoor air – residential: ([Stapleton et al. 2008](#)); ([Abb et al. 2011](#)); ([Abdallah and Harrad 2009](#)); ([Roosens et al. 2009](#)); ([Santillo et al. 2003](#)); ([Abdallah et al. 2008](#)); ([Abdallah et al. 2008](#)); ([D'Hollander et al. 2010](#)); ([Johnson et al. 2013](#)); ([Sahlström et al. 2012](#)); ([Ali et al. 2012](#)); ([Shoeib et al. 2012](#)); ([de Wit et al. 2012](#)); ([Roosens et al. 2010a](#)); ([Abdallah et al. 2008](#)); ([Stapleton et al. 2014](#)); ([Fromme et al. 2014](#)); ([Schreder and La Guardia 2014](#)); ([Dodson et al. 2012](#)); ([Newton et al. 2015](#)); ([Sahlström et al. 2015](#)); ([Mizouchi et al. 2015](#)); ([Kuang et al. 2016](#)); ([Coelho et al. 2016](#))
- ^m Indoor air – PCB: ([Abdallah and Harrad 2009](#)); ([Santillo et al. 2001](#)); ([Abdallah et al. 2008](#)); ([Abdallah et al. 2008](#)); ([D'Hollander et al. 2010](#)); ([de Wit et al. 2012](#)); ([Roosens et al. 2010a](#)); ([Takigami et al. 2009](#)); ([Newton et al. 2015](#)); ([Leonards et al. 2001](#)); ([Al Bitar 2004](#)); ([Takigami et al. 2008](#)); ([Allgood et al. 2016](#)); ([Harrad et al. 2010](#)); ([Newton et al. 2015](#)); ([Mizouchi et al. 2015](#))
- ⁿ Indoor air – vehicle: ([Abdallah and Harrad 2009](#)); ([Abdallah et al. 2008](#)); ([Harrad and Abdallah 2011](#)); ([Allen et al. 2013](#)); ([de Wit et al. 2012](#))
- ^o Soil: ([Covaci et al. 2009](#); ([Newton et al. 2015](#))
- ^p Handwipe: ([Tay et al. 2018](#))

2.4.2.2.1 Diet — Ingestion

For general population exposure, EPA estimated dietary exposure from all food groups based on monitoring data. The exposure dose associated with ingesting food is generally derived by multiplying the concentration of chemical in food or breastmilk by the ingestion rate for that food and dividing by body weight ([U.S. EPA 1992](#)). Within this overall framework, exposures could be estimated by grouping all foods and liquids together and using a generic overall exposure factor, disaggregating discrete food groups and using food group specific exposure factors, or estimating exposures for unique food items. EPA used available monitoring data to estimate central tendency and high-end concentrations of HBCD in specific food groups.

Equations

The equation used to calculate the chronic dose for each age group due to dietary exposure of fruits, grains, vegetables, meat, dairy, fats, and seafood is presented in Equation 2-12 below.

Equation 2-12

$$ADD = \frac{FC \times IR \times ED}{AT}$$

Where

ADD = Average daily dose used for chronic non-cancer risk calculations due to ingestion of food group (mg/kg-day)

FC = HBCD concentration in food group (mg/g)
 IR = Food group ingestion rate by age group (g/kg bw-day)
 ED = Exposure duration
 AT = Averaging time

The equation used to estimate exposure from ingestion of breastmilk is presented in Equation 2-13 below.

Equation 2-13

$$ADD = BMC \times BMR \times \rho$$

Where

ADD = Average daily dose used for chronic non-cancer risk calculations due to ingestion of breastmilk (mg/kg-day)
 BMC = Chemical concentration in breastmilk lipids (mg/g)
 BMR = Breastmilk lipid ingestion rate (mL/kg-day)
 ρ = Density of human breastmilk, 1.03 (g/mL)

Concentrations

Table 2-83 shows the central and high-end HBCD concentrations in the various food groups and breastmilk. The central tendency concentrations were used in the central ADD estimate and the high-end concentration was used in the high-end ADD estimate. Charts depicting concentrations in all extracted studies are provided in the *Risk Evaluation for Cyclic Aliphatic Bromide Cluster (HBCD), Supplemental Information on General Population, Environmental, and Consumer Exposure Assessment*.

For fruits, grains, vegetables, meat, dairy, fats, and seafood EPA used market basket monitoring studies to identify concentrations of HBCD present in different food groups. Only one U.S. market basket study was identified. In this study ([Schechter et al. 2012](#)) measured HBCD stereoisomers in a variety of common lipid-rich U.S. foods purchased from supermarkets in Dallas, TX in 2010. Thirty-six individual foods were sampled, generally consisting of fish (including bottom-feeders), poultry, pork, beef and peanut butter. HBCD were measured in only 15 individual food samples (detection frequency of 42%). Total HBCD in the individual food samples ranged from non-detect to 1.366 ng/g ww. The median and mean of total HBCD for all the samples were 0.012 and 0.114 ng/g ww, respectively. The highest concentration was detected in canned sardines, followed by smoked turkey. Concentrations in this U.S. study were similar to, although slightly lower than, market basket surveys in other countries. For example, total HBCD concentrations ranged from non-detect to 0.75 ng/g ww in a 2004 UK Total Diet Study ([FSA 2006](#)), non-detect to 10.1 ng/g ww in a 2013 UK study ([Fernandes et al. 2016](#)), and non-detect to 4.90 ng/g ww in a 2012-2014 Korean study ([Barghi et al. 2016](#)). Fish exhibited the highest or close to highest concentrations in all these studies, but the detection was not restricted to only fish or meat. In ([Barghi et al. 2016](#)), HBCD was detected in all eight food categories (fish, shellfish, meat, eggs, cereals, vegetables, fruits and dairy products), and was only not detected in yogurt and onions. Numerous other studies also examined seafood. The highest total HBCD wet weight concentration measured in seafood was 77.3 ng/g ww in a sample collected from a Japanese market in 2005 ([Nakagawa et al. 2010](#)).

Market basket seafood is different from wild-fish caught in a river. Market-basket monitoring studies typically collect many samples and may pool similar types of foods together for chemical or statistical analysis. The levels of HBCD present in market basket food groups are typically lower than levels

detected in wild animals and plants, especially if collected in industrial areas or near point sources. For example, in aquatic species, total HBCD has been detected in blubber of harbor porpoises at up to 19,208 ng/g ww in the UK ([Law et al. 2006](#)) and in bivalves at up to 362,900 ng/g lw in the U.S. at a WWTP outfall ([La Guardia et al. 2010](#)). Fish ingestion from wild-caught fish is discussed in the highly exposed population section.

Breast milk ingestion is an exposure pathway specific to infants. HBCD may be present in mothers in the general population or in highly exposed mothers through subsistence fish exposure or via occupational exposures. It is likely that that breastmilk concentrations are higher in women who consume more fish. The highest concentrations were observed by ([Eljarrat et al. 2009](#)), in which HBCD was measured in milk samples collected from women in Spain, ranging from ND to 188 µg/kg lw, with an average of 47 µg/kg lw and a median of 27 µg/kg lw. Another study by ([Eggesbø et al. 2011](#)), collected milk samples from 193 mothers as part of the Norwegian Human Milk Study. HBCD levels in breast milk ranged from 0.1 to 31 µg/kg lw, with an average of 1.1 µg/kg lw. In the United States, ([Carignan et al. 2012](#)) measured HBCD in the breast milk of 43 mothers. HBCD was detected in all samples with concentrations ranging from 0.36 to 8.1 µg/kg lw, with a geometric mean of 1.02 µg/kg lw.

Ingestion Rates

For fruits, grains, vegetables, meat, dairy, fats, and seafood EPA used mean and 95th percentile age-specific ingestion rates to calculate the central and high-end doses, respectively, with the exception that 50th percentile and 90th percentile ingestion rates were used for fish/shellfish. The ingestion rates (mg/kg-day) were obtained from the Exposure Factors Handbook ([U.S. EPA 2011b](#)); ([U.S. EPA 2018j](#)); ([U.S. EPA 2017i](#)); ([U.S. EPA 2018i](#)) for fruits, vegetables, grains, meats, dairy, fats, and breast milk. For seafood ingestion rates, EPA used data from ([U.S. EPA 2014b](#)) along with mean body weights for each age group from Exposure Factors Handbook ([U.S. EPA, 2011b](#)) to calculate a g/kg-day ingestion rate. Although infants (birth to one year) may consume fish, fish ingestion was considered to be negligible for this group because fish would only be consumed for a fraction of the first year of life (starting at 4 to 6 months when solid food is first introduced), the percent of the infant population that consumes fish is extremely small (only 2.6% of the population), and the mean ingestion rates for fish (0.03 g/kg/day for the whole population or 1.3 g/kg/day for consumers only from Exposure Factors Handbook ([U.S. EPA, 2011b](#))) is a small fraction of the total diet. Table 2-83 shows the HBCD concentrations and the range of ingestion rate used in the dose calculation by food group. See Appendix G for the specific values used for each age group.

Breastmilk lipid ingestion rates were obtained from the Exposure Factors Handbook ([U.S. EPA, 2011b](#)) and age weighted to calculate an ingestion rate for birth to <1 year old, then multiplied by the density of human breastmilk (1.03 g/mL) to obtain an ingestion rate of g/kg-day. The calculated central tendency ingestion rate was 4.2 g/kg-day and the high-end ingestion rate was 6.4 g/kg-day.

Table 2-83. Summary of Concentrations and Ingestion Rates Used in General Population Diet Exposure Estimate

Food group	HBCD concentration (mg/g ww)		Range of ingestion rates (g/kg-day)	
	Central tendency	High-end	Central tendency	High-end
Fruits	2.6E-08	5.5E-08	1.4E+00-9.9E+00	4.3E+00-2.7E+01
Vegetables	1.6E-07	1.9E-07	2.5E+00-6.7E+00	6.0E+00-1.9E+01

Grains	8.2E-08	1.1E-07	2.0E+00-6.4E+00	4.3E+00-1.3E+01
Meats	1.1E-07	1.8E-07	1.7E+00-4.0E+00	3.8E+00-9.6E+00
Dairy	1.6E-07	2.4E-07	3.3E+00-4.9 E+01	9.9E+00-1.0E+02
Fats	1.7E-07	2.3E-07	1.1E+00-4.6E+00	2.0E+00-8.9E+00
Seafood	2.0E-06	4.1E-06	1.9E-02-6.3E-02	1.5E-02-4.1E-02
Breastmilk	4.4E-06	8.7E-06	4.2E+00	6.4E+00

Exposure Duration and Averaging Time

The years within an age group (*e.g.*, 1 year for infants) was used for the exposure duration and averaging time.

HBCD in Drinking Water

EPA considered ingestion of drinking water but did not quantify those concentrations in this Risk Evaluation. The concentration of HBCD in surface water is generally low and monitored levels of HBCD in drinking water are unavailable. Other assessments have included drinking water as a pathway and noted that expected exposures are quite low. The following exposure pathways are possible:

1. Ingestion of finished water at the tap, expected HBCD levels are low.
2. Ingestion of surface water, including suspended sediment, during recreation in lakes and rivers. HBCD levels are likely slightly more elevated than drinking water but intake rates and frequency of exposure are lower.

2.4.2.2.2 Dust and Soil — Incidental Ingestion

The exposure dose associated with incidentally ingested dust and soil is generally derived by multiplying the chemical concentration in dust or soil by the empirically derived ingestion rate of dust or soil and dividing by body weight ([U.S. EPA 1992](#)). The ingestion rate can be derived through tracer methods which measure tracer chemicals present both in soil and dust and in the urine and feces of humans and through biokinetic methods that use biomonitoring data and physiologically based pharmacokinetic (PBPK) models to back-calculate ingestion rates. An activity-pattern based method models hand-to-mouth and object-to-mouth contact to derive transfer rates of soil and dust to the mouth to estimate ingestion rate ([Moya and Phillips 2014](#)). Estimated ingestion rates based on the activity-pattern method are informed by empirically and estimated variables ([Ozkaynak et al. 2011](#)) including:

- Hand and object to mouth frequency indoors and outdoors
- Dust loading
- Object: floor dust loading ratio
- Soil skin adherence rate
- Skin/soil surface contact rate
- Maximum dermal loading of soil loading on hands
- Surface to hand dust transfer efficiency
- Hand to mouth and object to mouth transfer efficiency
- Area of object mouthed and fraction of hand mouthed/event
- Bath and hand wash removal efficiency and frequency

Chemical concentrations in dust or soil are required for the tracer and biokinetic methods. Loadings of a chemical in dust or soil are required for the activity-pattern method. The chemical concentration in dust or soil is defined as the mass of chemical present per mass of dust or soil. The chemical loading in dust

is defined as the mass of chemical per surface area.

These variables are all related, but often only one of the three is reported in monitoring studies. If the surface area units are the same for loadings, the chemical dust loading divided by the total dust loading is equal to the chemical concentration. However, dust loadings of overall levels can also vary substantially by building or within a building. If paired chemical dust loading and chemical concentration data are available, an empirical relationship can be used to derive a relationship and conversion equation.

When an activity pattern method is used an overall dust or soil factor (units surface area/time) that incorporates variability from the bulleted list above can be used to estimate intake.

A wide range of studies have reported HBCD concentrations in dust in a variety of indoor environments. No studies were identified that specified HBCD loadings in dust. Therefore, empirically-derived ingestion rates based on the tracer and biokinetic approaches were used for this assessment.

Equations

EPA used Equation 2-14 to estimate HBCD doses from dust ingestion and Equation 2-15 to estimate HBCD doses from soil ingestion.

Equation 2-14

$$ADD = \frac{DC \times IR \times FD \times CF_1 \times ED}{BW \times AT}$$

Where

- ADD* = Average daily dose used for chronic non-cancer risk calculations due to dust ingestion (mg/kg-day)
- DC* = Dust concentration (µg/mg) (see explanation below)
- IR* = Dust ingestion rate (g/day)
- CF₁* = Conversion factor for mg/µg
- FD* = Fraction of time spent awake spent in indoor microenvironments
- ED* = Exposure duration
- BW* = Body weight (kg)
- AT* = Averaging time

Equation 2-15

$$ADD = \frac{DC \times IR \times FD \times CF_1 \times ED}{BW \times AT}$$

Where

- ADD* = Average daily dose used for chronic non-cancer risk calculations due to soil ingestion (mg/kg-day)
- DC* = Soil concentration (µg/mg)
- IR* = Soil ingestion rate (g/day)
- CF₁* = Conversion factor for mg/µg
- ED* = Exposure duration
- BW* = Body weight (kg)
- AT* = Averaging time

This HBCD assessment uses Equation 2-14 and Equation 2-15, while future assessments may use Equation 2-16 depending on data availability.

Equation 2-16

$$ADD = \frac{DL \times DF \times TS \times ED}{BW \times AT}$$

Where

- ADD* = Average daily dose used for chronic non-cancer risk calculations due to soil or dust ingestion (mg/kg-day)
DL = Dust or soil loading ($\mu\text{g}/\text{cm}^2$)
DF = Dust or soil factor ($\text{cm}^2/\mu\text{g} * \text{mg}/\text{hr}$)
TS = Time spent in different microenvironments, total should equal time awake (hr/day)
ED = Exposure duration (years)
BW = Body weight (kg)
AT = Averaging time (years)

Concentrations

Table 2-84 presents the dust and soil concentrations that were used in Equation 2-14 and Equation 2-15 to estimate exposures from dust and soil ingestion. For dust, the concentrations were classified based on the sampling microenvironment: residential, public and commercial building, and automobile. For soil, the background (away from facility) concentrations estimated in the environmental exposure assessment were also used in the general population assessment. The central tendency concentrations were used in the central ADD estimate and the high-end concentration was used in the high-end ADD estimate. Charts depicting concentrations in all extracted studies are provided in the *Risk Evaluation for Cyclic Aliphatic Bromide Cluster (HBCD), Supplemental Information on General Population, Environmental, and Consumer Exposure Assessment*.

Indoor dust studies were prevalent for residential and public/commercial building settings, and lesser so for vehicles. The final dataset includes five studies (all residential) conducted in the U.S. between 2006 and 2012. In the most recent U.S. study ([Stapleton et al. 2014](#)), total HBCD was detected in detected in all samples collected from thirty North Carolina homes in 2012, with a geometric mean of 3.4 E-04 $\mu\text{g}/\text{mg}$ (range of 7.8 E-05 to 2.6 E-03 $\mu\text{g}/\text{mg}$). These values are within the same order of magnitude as the central and high-end estimated indoor residential dust values used in this assessment, as shown in Table 2-84.

Studies measuring the concentration of HBCD in soil are limited, with most studies measuring samples located near industrial facilities. As discussed in the Environmental Exposure section, no U.S. soil studies were identified and therefore background soil concentrations were derived from only two small studies conducted in Belgium and Sweden ([Covaci et al. 2009](#)) and ([Newton et al. 2015](#)).

Exposure Factors

Fraction of time spent awake in indoor microenvironments: For dust, the concentration in each microenvironment was weighted based on the fraction of time spent in each microenvironment. The time spent by children and adults in each of these microenvironments was estimated for three generic activity-pattern profiles (stay at home, part-time school/home, and full-time school/home) informed by EPA's Consolidated Human Activity Patterns Database ([U.S. EPA 2009b](#)). The hours spent in each microenvironment were used to derive a fraction of the day that an individual was exposed to the

selected HBCD concentrations in each microenvironment. The median fraction was used for the central ADD estimate and the maximum fraction was used for the high-end ADD estimate. See Appendix G for the fraction of time spent awake spent in indoor microenvironments for the three generic activity profiles.

Ingestion Rates: The central tendency and high-end dust ingestion and soil ingestion rates from the Chapter 5 Update of Exposure Factors Handbook ([U.S. EPA 2011b](#)) were used in the central and high-end ADD calculations, respectively.

Table 2-84. Summary of Dust and Soil Inputs Used in Estimating Dust and Soil Ingestion Dose for HBCD

Parameter	Central Tendency	High-end
Dust Concentration Residence (µg/mg)	1.5E-03	2.9E-03
Dust Concentration PCBs (µg/mg)	1.5E-03	2.9E-03
Dust Concentration Vehicle (µg/mg)	1.7E-02	3.2E-02
Soil Concentration Background (µg/mg)	1.4E-06	3.0E-06
Range of Dust Ingestion Rates (varies by age group) (mg/day)	2.0E+01-5.0E+01	6.0E+01-1.0E+02
Range of Soil Ingestion Rates (varies by age group) (mg/day)	1.0E+01-4.0E+01	5.0E+01-9.0E+01

Exposure Duration and Averaging Time

The years within an age group (*e.g.*, 1 year for infants) was used for the exposure duration and averaging time.

2.4.2.2.3 Air — Inhalation

Equations

Equation 2-17 was used to estimate dose from ingestion of suspended particles in air is below. For indoor air, the concentration of HBCD particulate can be derived directly from air monitoring data or estimated from measured indoor dust monitoring or total indoor air (vapor and particulate) concentrations. This assessment uses air monitoring data for both outdoor and indoor environments.

Equation 2-17

$$ADD = \frac{AC \times IR \times IF \times FD \times ED}{BW \times AT}$$

Where

- ADD* = Average daily dose used for chronic non-cancer risk calculations due to suspended particle ingestion (mg/kg- day)
- AC* = Concentration of particulates in air (mg/m³) See explanation below
- IF* = Fraction of inhaled particles that are ingested (1; unitless)
- IR* = Inhalation rate (m³/day)
- FD* = Fraction of day spent in microenvironment (unitless)
- ED* = Exposure duration
- BW* = Body weight (kg)
- AT* = Averaging time

Concentrations

Table 2-85 presents the indoor and outdoor air concentrations that were used to estimate exposures from inhalation using Equation 2-17. As with dust, the air concentrations were also classified based on the sampling microenvironment: outdoor, residential, public and commercial building, and automobile. The central tendency concentrations were used in the central ADD estimate and the high-end concentration was used in the high-end ADD estimate. Charts depicting concentrations in all extracted studies are provided in the *Risk Evaluation for Cyclic Aliphatic Bromide Cluster (HBCD), Supplemental Information on General Population, Environmental, and Consumer Exposure Assessment*.

Studies of HBCD in ambient air are limited. In the only U.S. study, [Hoh and Hites 2005](#) measured HBCD in five sites across five states and detected HBCD in 120 of 156 samples. Across all sites central tendency concentrations ranged from approximately 1 to 5 E-06 $\mu\text{g}/\text{m}^3$, which is approximately an order a magnitude lower than the estimated concentrations in Table 2-85. Indoor air data was extracted from ten studies, but no U.S. data was identified.

The distribution of HBCD between gas-phase and particle phase in indoor air and the resulting particle size distribution is an important consideration. Smaller particles are expected to be respirable while larger particles are expected to be inhalable. The particle size distribution was not available for many monitoring studies, although most studies did report whether the sample was particulate or vapor. Only particulate values were considered for this pathway.

Exposure Factors

Fraction of time in a day spent in indoor microenvironments:

Similar to dust, the fraction of time spent by children and adults in each of the microenvironments was estimated for three generic activity-pattern profiles informed by EPA's CHAD ([U.S. EPA 2009b](#)) stay at home, part-time school or work, and full-time work or school. For air, the fraction is based on a 24-hr day. The median fraction was used for the central ADD estimate and the maximum fraction was used for the high-end ADD estimate. See Appendix G for the fraction of time spent in the microenvironments over 24 hours for the three generic activity profiles.

Inhalation rates: The central tendency and high-end dust inhalation rates from the Chapter 5 Update of Exposure Factors Handbook ([U.S. EPA 2011b](#)) were used in the central and high-end dose calculations, respectively.

Table 2-85 Inputs for Estimation of HBCD Inhalation Dose

Parameter	Central Tendency	High-end
Air Concentration Outdoors ($\mu\text{g}/\text{m}^3$)	1.96E-05	2.96E-05
Air Concentration Residence ($\mu\text{g}/\text{m}^3$)	1.00E-04	2.26E-03
Air Concentration P&CBs ($\mu\text{g}/\text{m}^3$)	9.10E-04	1.91E-03
Air Concentration Vehicle ($\mu\text{g}/\text{m}^3$)	2.44E-06	3.27E-06
Range of Inhalation Rates (varies by age group) (m^3/day)	5.4 E+00-1.6E+01	9.2E+00-2.5E+01

Exposure Duration and Averaging Time

The years within an age group (*e.g.*, 1 year for infants) were used for the exposure duration and averaging time.

2.4.2.2.4 Dermal

EPA used a fractional absorbed approach to estimate dermal exposures from contact with dust, soil, and materials containing HBCD. Two different estimation methods were used. The first method was based on empirical data where levels of HBCD present in dust on people's hands was sampled using hand-wipes (direct estimation method). The second method was based on measured dust and soil concentrations and age-specific dust-skin and soil-skin adherence factors (indirect estimation method). After estimating the dermal loading, an absorption fraction of 6.5% was applied as discussed in Section 3.2.2.1.1. These methods are described in more detail below.

For the direct estimation approach, Equation 2-18 was used:

Equation 2-18

$$ADD = \frac{C_{hw} \times FR_{abs} \times \frac{SA}{BW} \times CF \times EF \times ED}{AT}$$

- ADD* = Average daily dose used for chronic non-cancer risk calculations due to skin contact with dust, soil, or materials (mg/kg-day)
C_{hw} = Concentration in hand wipe (pg/cm²)
FR_{abs} = Dermal absorption fraction (6.5%)
SA/BW = Surface area of both hands/bodyweight ratio (cm²/kg)
CF = Conversion factor (10E-9 mg/pg)
EF = Exposure frequency (1 event/day)
ED = Exposure duration (years in age group)
AT = Averaging time, non-cancer (years in age group)

EPA used HBCD-specific hand wipe concentrations from [Tay et al. 2018](#). In this study hand wipe samples were collected from a Norwegian cohort of 61 adults between November 2013 and April 2014. Participants were instructed not to wash their hands at least 60 minutes prior to sampling. Samples were collected from both hands separately using sterile gauze pads immersed in isopropanol, and combined into one sample prior to analysis by ultra-performance liquid chromatography–mass spectrometry (UPLC-MS). The LOQ ranged from 20 to 45 ng/participant per isomer. The mass of total HBCD (including α, β, and γ isomers) per participant was 49 to 8,900 ng with a median of 180 ng and a mean of 680 ng (n = 60; detection frequency of 57 to 80% per isomer). After normalization for the surface area of the participants hand, as estimated by an equation adopted from [U.S. EPA 2011b](#) which incorporates the weight and height of the participant, total HBCD ranged from 27 to 11,000 pg/cm², with a median of 150 pg/cm² and a mean of 760 pg/cm². The mean value of 0.76 ng/cm² was selected for the central ADD estimate and the maximum value of 11 ng/cm² was selected for the high-end ADD estimate. The study also collected settled dust samples from elevated levels in the living room of participants. The authors noted that positive and significant correlations were found between settled dust and hand wipes for gamma HBCD, which indicates that the levels of HBCD on the skin surface might be a consequence of contact with elevated surface dust in the home.

One other hand wipe study was identified ([Stapleton et al. 2014](#)). In this study hand wipe samples were collected in 2012 from 43 children, age 2 to 6, living in North Carolina. The gauze samples were analyzed for individual HBCD isomers (alpha, beta, and gamma) using gas chromatography–mass spectrometry (GC/MS). Total HBCD (sum of isomers) ranged from ND (<0.05) to 10.8 ng/participant,

with a geometric mean of 0.97 ng/participant (n = 43; detection frequency of 40 to 53% per isomer). Stapleton et al. 2014 did not normalize the results based on surface area of the participants hands. Using a value of 3.7 cm², the mean surface area of hands for children ages 2 to <6 years ([U.S. EPA 2011b](#)), the maximum and geometric mean values would be 2.9 and 0.26 ng/cm², respectively.

The levels detected in handwipes based on sampling of adults in [Tay et al. 2018](#) were about three to four times higher in magnitude than the levels detected in handwipes based on sampling of children in [Stapleton et al. 2014](#). Some of the difference may be attributable to differences in activity patterns and hand-to-mouth behaviors between adults and young children. As both studies used a relatively small and potentially homogeneous group of participants, the concentrations from [Tay et al. 2018](#) were selected for all populations as a conservative estimate.

The surface area to body weight ratios used in Equation 2-18 are based on the 50th percentile values reported in [U.S. EPA 2011b](#). Refer to Appendix G for a summary of exposure factors used in the human exposure assessment.

For the indirect estimation approach, Equation 2-19 was used:

Equation 2-19

$$ADD = \frac{Conc. \times FR_{abs} \times AF \times \frac{SA}{BW} \times CF1 \times CF2 \times EF \times ED}{AT}$$

ADD = Average daily dose used for chronic non-cancer risk calculations due to skin contact with dust, soil, or materials (mg/kg-day)

Conc. = Concentration in soil and dust (µg/mg)

FR_{abs} = Dermal absorption fraction (6.5%)

AF = Adherence factor (mg/cm²)

SA/BW = Surface area of hands, face, and arms/bodyweight ratio (cm²/kg)

CF1 = Conversion factor (0.001 g/mg)

CF2 = Conversion factor (0.001 mg/µg)

EF = Exposure frequency (1 event/day)

ED = Exposure duration (years in age group)

AT = Averaging time, non-cancer (years in age group)

EPA used the same dust concentrations (weighted average based on microenvironment) and soil concentrations calculated for the general population (refer to Section 2.4.2.2.2) to estimate dermal exposure. The amount the dust and soil expected to adhere to the skin was accounted for through adherence factors weighted based on the surface area of the body parts exposed to the dust and soil. Exposure Factor Handbook ([U.S. EPA 2011b](#)) provides recommended adherence factors by body part for adults and children based on a limited number of observations for a limited set of activities that primarily focus on soil. The recommended values for “activities with soil” were selected for the soil pathways, and “residential, indoors” was selected for the dust pathway where available. The value was not reported for adults, and the “activities with soil” was used in absence of dust-specific adherence values. These values were weighted using equation 7-1 in [U.S. EPA 2011b](#) assuming that exposed body parts are hands, lower legs (45% of total leg), and lower arms (50% of lower arms). For context, this represents a short sleeve shirt and shorts scenario, or approximately 25% of the body. The surface area to body weight ratios used in the equation are based on the 50th percentile values reported in Exposure

Factors Handbook ([U.S. EPA 2011b](#)). Refer to Appendix G for a summary of exposure factors used in the human exposure assessment.

Table 2-86 provides the results for both methods. It should be noted that the direct handwipe method results are an order of magnitude larger than the indirect adherence method results. The average of the direct and indirect methods was used in the exposure assessment. For the indirect (adherence) method, the dose from dust was approximately 10 to 200 times the dose from soil.

Table 2-86. Age Specific ADD for Dermal Exposure from Dust, Soil, and Materials

	Dermal Central (mg/kg/day)			Dermal High-End (mg/kg/day)		
	Direct	Indirect	Average	Direct	Indirect	Average
Infant (<1 year)	1.9E-05	8.4E-09	9.7E-06	1.3E-06	2.8E-09	6.7E-07
Young Toddler (1-<2 years)	1.9E-05	7.9E-09	9.4E-06	1.3E-06	2.7E-09	6.5E-07
Toddler (2-<3 years)	1.5E-05	7.2E-09	7.3E-06	1.0E-06	2.4E-09	5.0E-07
Small Child (3-<6 years)	1.4E-05	6.8E-09	7.1E-06	9.8E-07	2.3E-09	4.9E-07
Child (6-<11 years)	1.1E-05	5.8E-09	5.7E-06	7.9E-07	2.0E-09	4.0E-07
Teen (11-<16 years)	9.1E-06	4.5E-08	4.6E-06	6.3E-07	1.5E-08	3.2E-07
Adult (16-<78 years)	8.8E-06	4.2E-08	4.4E-06	6.1E-07	1.4E-08	3.1E-07

2.4.2.2.5 Aggregate General Population Exposure and Dose

The approach for estimating general population exposures was discussed throughout Section 2.4.2 for the diet, dust, soil, air, and dermal pathways. The resulting doses arrayed by pathway and age group are summarized in Table 2-87 (central tendency) and Table 2-89 (high-end), and the relative contribution of each pathway to the aggregated exposure is presented in Table 2-88 (central tendency) and Table 2-90 (high-end). A breakdown of dietary doses based on food group is provided in Appendix G. Based on these calculations, it can be seen that the predominant sources of exposure are from dust ingestion and diet, with the contribution of dust to the overall exposure being much more dominant in younger age groups. This is likely due to the exposure factors and behavior patterns of infants, young toddlers and children as they spend more time closer to sources of settled dust and are more likely to exhibit hand to mouth behaviors. The contribution of air is also predominant for the acute dose with more dominant exposure in the older age groups.

Table 2-87. General Population Central Tendency HBCD Exposure by Pathway and Age Group - (mg/kg/day)

Age Group	DIET	DUST	SOIL	AIR	DERMAL	ALL
Infant (<1 year)	2.4E-05	1.5E-05	4.6E-09	5.8E-07	6.7E-07	4.0E-05
Young Toddler (1-<2 years)	1.1E-05	1.7E-05	5.0E-09	5.9E-07	6.5E-07	2.9E-05
Toddler (2-<3 years)	8.7E-06	8.4E-06	3.1E-09	5.5E-07	5.0E-07	1.8E-05
Small Child (3-<6 years)	6.2E-06	6.3E-06	2.3E-09	4.6E-07	4.9E-07	1.3E-05
Child (6-<11 years)	4.1E-06	3.7E-06	1.4E-09	3.2E-07	4.0E-07	8.5E-06
Teen (11-<16 years)	2.3E-06	1.5E-06	3.4E-10	2.3E-07	3.2E-07	4.3E-06
Adult (16-<70 years)	1.6E-06	9.7E-07	1.8E-10	1.7E-07	3.1E-07	3.1E-06

Table 2-88. General Population Central Tendency Source Contribution by Pathway and Age Group (% Contribution to Total HBCD Exposure)

Age Group	DIET	DUST	SOIL	AIR	DERMAL
Infant (<1 year)	59.5%	37.3%	0.011%	1.5%	1.7%
Young Toddler (1-<2 years)	37.4%	58.3%	0.017%	2.0%	2.2%
Toddler (2-<3 years)	47.7%	46.5%	0.017%	3.0%	2.8%
Small Child (3-<6 years)	46.4%	46.6%	0.017%	3.4%	3.7%
Child (6-<11 years)	48.6%	43.0%	0.016%	3.7%	4.7%
Teen (11-<16 years)	53.2%	34.2%	0.008%	5.2%	7.4%
Adult (16-<70 years)	53.1%	31.5%	0.006%	5.4%	10.0%

Table 2-89. General Population High-End HBCD Exposure by Pathway and Age Group (mg/kg/day)

Age Group	DIET	DUST	SOIL	AIR	DERMAL	ALL
Infant (<1 year)	8.1E-05	7.6E-05	2.7E-08	2.3E-06	9.7E-06	1.7E-04
Young Toddler (1 - <2 years)	3.5E-05	6.5E-05	2.4E-08	2.2E-06	9.4E-06	1.1E-04
Toddler (2-<3 years)	2.9E-05	5.4E-05	2.0E-08	2.0E-06	7.3E-06	9.2E-05
Small Child (3-<6 years)	2.1E-05	4.0E-05	1.5E-08	1.5E-06	7.1E-06	7.0E-05
Child (6-<11 years)	1.4E-05	2.3E-05	8.5E-09	1.0E-06	5.7E-06	4.4E-05
Teen (11-<16 years)	8.7E-06	8.7E-06	3.0E-09	7.6E-07	4.6E-06	2.3E-05
Adult (16-<70 years)	6.5E-06	5.6E-06	1.9E-09	5.2E-07	4.4E-06	1.7E-05

Table 2-90. General Population High-End Source Contribution by Pathway and Age Group (% Contribution to Total HBCD Exposure)

Age Group	DIET	DUST	SOIL	AIR	DERMAL
Infant (<1 year)	47.9%	44.9%	0.016%	1.4%	5.8%
Young Toddler (1-<2 years)	31.4%	58.2%	0.021%	2.0%	8.4%
Toddler (2-<3 years)	31.3%	58.6%	0.021%	2.1%	7.9%
Small Child (3-<6 years)	30.4%	57.3%	0.021%	2.1%	10.2%
Child (6-<11 years)	32.1%	52.6%	0.019%	2.3%	12.9%
Teen (11-<16 years)	38.2%	38.4%	0.013%	3.4%	20.1%
Adult (16-<70 years)	38.3%	32.8%	0.011%	3.1%	25.8%

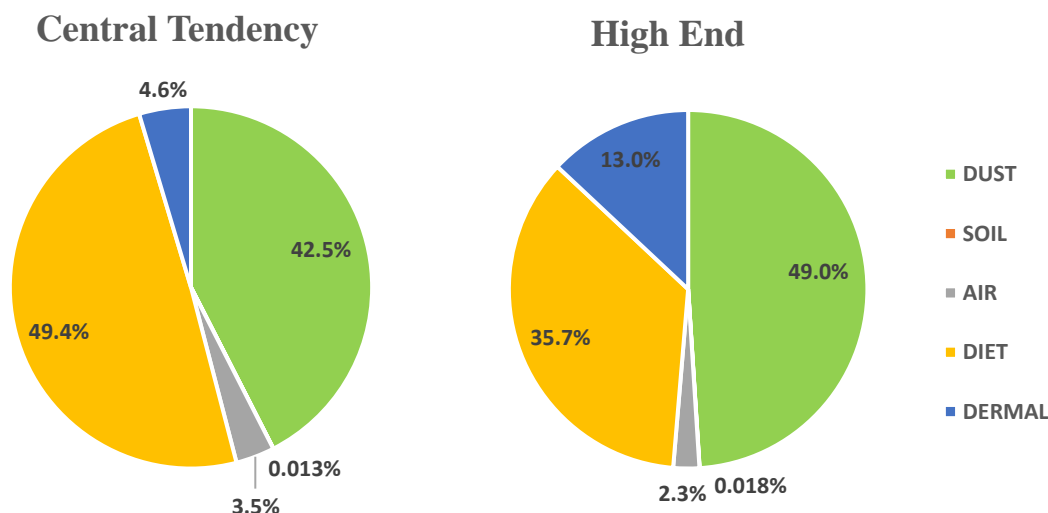

Figure 2-5. Source Contribution by Pathway for Aggregate General Population Exposures

Estimated doses using the indirect estimation method from completed assessments were also examined to compare against EPA's calculated doses. Dose estimates in completed assessments represent a wide variety of countries (at least 18), populations, age groups, pathways, and exposure scenarios. The extracted doses range from 1.8 E-13 to 2.75 mg/kg/day, with the highest dose attributed to intake from the industrial use of HBCDD as textile back-coating agent ([EINECS 2008](#)). Other completed assessment doses higher than the EPA calculated general population doses were reported for a local industry specific scenario - emissions from EPS formulation ([ECHA 2017b](#)).

2.4.2.2.6 Occupational Microenvironments

Occupational microenvironments represent settings where workers may be exposed to residual, background levels of HBCD. These may include exposures due to formulated products and articles (*e.g.*, textiles, electrical and electronic products, adhesives, and coatings). For estimating exposure from occupational microenvironments, aggregate concentrations were estimated from various non-residential microenvironments relevant to the general population *i.e.*, mixed use, vehicle, commercial, public buildings, and schools. These include available dust and air concentration data found in various school rooms (classrooms, computer rooms, gymnasiums), government buildings, car cabins, car trunks, airplanes, and waste electronics facilities) and represent a small subset of total aggregate general population exposure (described in Section 2.4.2.1 with results presented in Section 2.4.2.2.5). Concentrations were estimated as previously described for dust (Section 2.4.2.2.2) and indoor air (Section 2.4.2.2.3), with high-end and central tendency doses for working age adolescents and adults (age 16 - 70) derived only from data for public commercial buildings (PCBs) and automobiles.

Table 2-91 present exposure estimates for occupational microenvironments. Because occupational microenvironments are represented by a subset of aggregate general population exposure, the table also shows a relative comparison of those exposure estimates as a percentage of the total aggregate exposure for each pathway and overall. Occupational microenvironments comprise the majority of aggregate dust exposure but only a small minority of inhaled air exposures and less than a third of total aggregate general population exposures. Exposures from formulated products and articles (*e.g.*, textiles, electrical and electronic products, adhesives, and coatings) comprise a non-quantifiable subset of the total occupational microenvironment exposure since these aggregate exposures likely include other sources as well, including releases stemming from historical activities (Section 1.2.9) due to HBCD's persistence.

Table 2-91. Occupational Microenvironments Doses as a Percentage of Aggregate General Population Exposure

Exposure Level	PCB + Auto Dust (mg/kg-day)	PCB + Auto Dust (% of total dust)	PCB + Auto Air (mg/kg-day)	PCB + Auto Air (% of total air)	Occup. Micro. Total (mg/kg-day)	Occup. Micro. (% of total aggregate)
High-End	4.7E-06	8.5E+01	5.2E-07	1.05%	5.3E-06	30.9%
Central Tendency	8.3E-07	8.5E+01	1.6E-07	4.49%	9.9E-07	32.1%

2.4.2.3 Exposure Reconstruction Using Human Biomonitoring Data and Reverse Dosimetry

EPA describes the approach used to estimate doses based on biomonitoring below. HBCD has been quantified in human samples in blood serum in adults, cord serum, breast milk, and adipose tissue in generally small, primarily European cohorts in a range of studies. An approach to estimate external doses of HBCD based on biomonitoring data is reported in [Aylward and Hays 2011](#). The approach uses a simple one-compartment model with a 64 day half-life of HBCD in the body ([Geyer et al. 2004](#)) coupled with an assumed percent lipid in the body, allowing ng/g lipid weight (lw) biomonitoring values reported in various matrices to be converted to external exposure doses (mg/kg/day).

HBCD human biomonitoring data were previously extracted from peer-reviewed studies and curated to produce one set of summary statistics per study. A total of 52 peer-reviewed studies, resulting in 64 data sets with sampling years from 1973 to 2015, reported HBCD data in human adipose tissue, blood, breast milk, feces, fetal tissue, hair, and placental tissue across the general population, occupational workers and highly exposed populations. Table 2-92 provides the number of data sets for each population and media type. Prior to any calculations of dose, the biomonitoring data were standardized to have the same concentration units of ng/g lipid as follows:

- 1) For data reported as ng/g whole blood or ng/g serum, it was assumed that the lipid content in whole blood and serum was 25%.
- 2) For data reported as ng/g hair, it was assumed that the lipid content in hair was 6%
- 3) For data reported as ng/L serum, the density of serum (1.024 g/mL as reported in Sniegowski and Moody, 1979) was used to convert volume to mass.

Table 2-92. Human HBCD Biomonitoring Data Sets by Population, Type and Number

Population	Media Type	No. of Data Sets
General	Adipose Tissue	4
General	Blood / Serum	14
General	Breast Milk	34
General	Feces	1
General	Hair	1
General	Placental / Fetal Tissue	2
Highly Exposed	Blood	2
Highly Exposed	Breast Milk	4
Highly Exposed	Hair	1
Occupational	Breast Milk	1

For each set of human biomonitoring data, the estimated external dose of HBCD was estimated using the approach in ([Aylward and Hays 2011](#)). This approach used a basic one-compartment, first-order pharmacokinetic (PK) model to estimate chronic daily dose. The mass balance equation for change in chemical mass in one compartment is:

$$\Delta M_c = (D \cdot BW \cdot \Delta t) - (k \cdot M_c \cdot \Delta t)$$

where M_c is the mass of HBCD in the body [mg]
 D is the chronic daily dose [mg/kg body weight/day]
 BW is the body weight [kg body weight]
 Δt is the change in time [days]
 k is the first-order elimination rate constant [1/day]

The following equations can be substituted into the mass balance equation:

$$C = \frac{M_c}{M_{lipid}}$$

$$M_{lipid} = BW \cdot F_l$$

$$k = \frac{\ln(2)}{t_{1/2}}$$

where C is the mass of HBCD per mass of lipid in the body [mg/kg lipid]
 M_{lipid} is the mass of lipid in the body [kg lipid]
 F_l is the fraction of body weight that is lipid [kg lipid/kg body weight]
 $t_{1/2}$ is the half-life of HBCD [days]

At steady state, this gives:

$$D = k \cdot C \cdot F_l$$

$$D = \frac{\ln(2)}{t_{1/2}} \cdot C \cdot F_l$$

In this model, the assumptions are:

- Steady state conditions
- Elimination of HBCD from the body is due to a first-order degradation process
- HBCD distributes equally in lipid throughout the body
- No difference in toxicokinetic parameters between different HBCD isomers

The parameter values used in ([Aylward and Hays 2011](#)), and subsequently used in the EPA calculations were:

- Fraction of body weight that is lipid was assumed to be 25%
- Half-life of HBCD was previously estimated by ([Geyer et al. 2004](#)) to be 64 days, with a range of 23 to 219 days. These values were calculated assuming:
 - HBCD concentrations of 250-2400 ng/kg fat (mean of 700) in human breast milk from non-occupationally exposed Swedish population based on values reported in ([Barregard 2003](#)).
 - A daily intake rate of 142 ng/day by adult humans in Sweden based on a market basket study, as reported in two studies of ([Darnerud 2003](#)) and ([Lind et al. 2003](#)).
 - The fraction of dose absorbed from food was 100%.

Although the HBCD concentrations in breastmilk and the intake values used in the half-life calculations are from abstracts or pre-published papers and could not be verified, the values are within similar magnitudes as other published values for the Swedish population in literature.

Changes to either of the two parameters, fraction of body weight that is lipid (F_l) and HBCD half-life ($t_{1/2}$), would change the estimated dose.

The estimated doses across all population types ranged from 1.1E-09 to 1.5E-02 mg/kg/day.

2.4.2.4 Comparison of General Population Approaches

The figure below shows how these two approaches compare. The overall distribution based on the biomonitoring data appears to be lognormal and the EPA estimated doses fall within the range of doses derived from. This comparison provides confidence that EPA is within the correct order of magnitude to estimate doses to the general population.

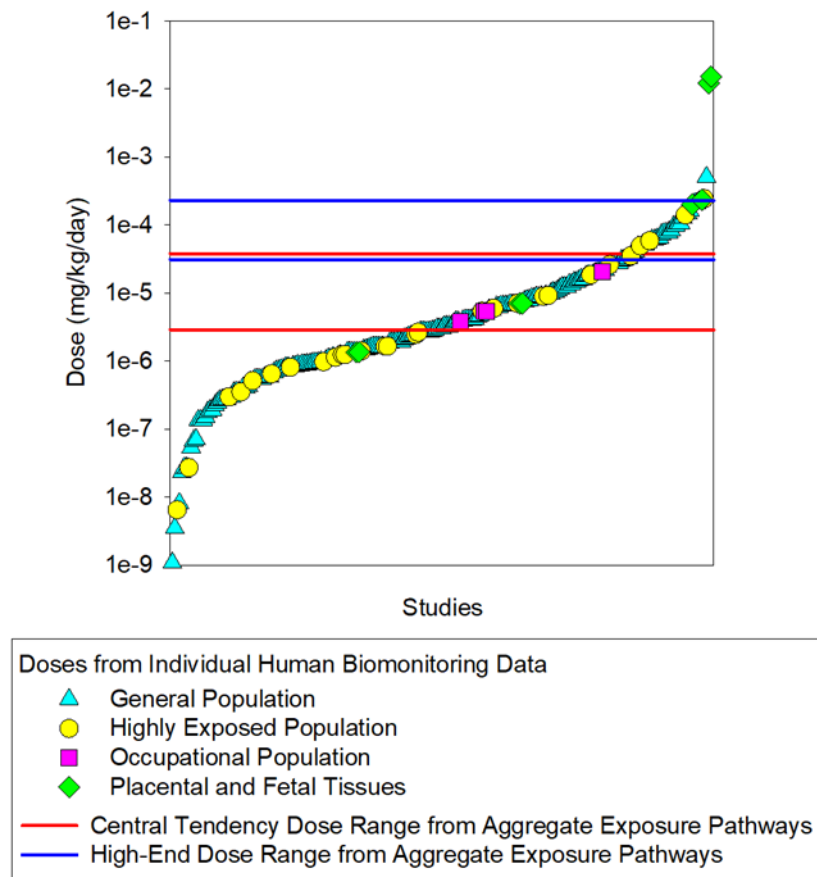

Figure 2-6. Comparison of HBCD Exposure via Environmental Monitoring/Exposure Factor and Human Biomonitoring/Reverse Dosimetry Approaches

As described earlier in the section, it is unknown how scenario-specific estimates of exposure for highly exposed populations compare to the doses estimated for the general population. It is also unknown how temporal trends will ultimately impact biomonitoring studies. One recent study from Australia has looked at biomonitoring of HBCD over time after their phase out. The authors note that while HBCD levels are starting to decline, it may be some time before levels decline significantly due to the persistence of HBCD in the body and ongoing sources of HBCD in the environment ([Drage et al. 2015](#)). This approach is for total HBCD, not specific to the isomeric forms. While not specifically addressed in this assessment, HBCD exists in three isomeric forms (alpha, beta, gamma). The different isomeric forms have $K_{\text{Octanol:Water}}$ values that differ by more than one log unit, whose biological half-lives vary significantly ([Szabo et al. 2011b](#); [Szabo et al. 2011a, 2010](#)). It is not known if the isomers have species specific differences in toxicokinetics or toxicodynamics between animals and humans. Given these uncertainties in the isomeric forms as well as in the pharmacokinetic data used in developing the equivalent doses, there are uncertainties in the estimated external exposure doses based on biomonitoring data. Biomonitoring studies in the literature are summarized in the *Risk Evaluation for Cyclic Aliphatic Bromide Cluster (HBCD), Supplemental Information on General Population, Environmental, and Consumer Exposure Assessment* ([U.S. EPA 2019d](#)). There is not a pharmacokinetic model to fully describe the relationship between HBCD dose and lipid-adjusted HBCD concentrations in humans, so therefore there is uncertainty associated with using a simpler approach to describe toxicokinetics and toxicodynamics of HBCD.

2.4.2.5 General Population Subsistence Fisher Exposures

Aggregate exposures were also estimated for subsistence fishers. Subsistence fishers represent a PESS group for HBCD due to their greatly increased exposure via fish ingestion (142.4 g/day compared to a high-end of 22.2 g/day for the general population). Based on the increased ingestion rate ([U.S. EPA 2000a](#)) and various measured HBCD concentrations in fish both downstream (Near Field) and far away (Far Field) from a releasing facility, EPA calculated aggregate general population exposure for subsistence fishers. While EPA did not model subsistence fisher exposures due to releases associated with a particular condition of use or OES, the use of measured HBCD concentrations in fish found downstream of a nearby facility provide a reasonable estimate of HBCD exposure fish ingestion for a highly exposed population.

EPA selected the best representative biomonitoring fish tissue concentrations from ([Chen et al. 2011](#)). In this U.S. study, HBCD fish tissue concentrations were measured in 2006-2007 in three rivers, one downstream of a nearby HBCD point source (Hyco River) and two others (Dan River, Roanoke River) representing far-field fish tissue concentrations. The data from common carp was selected to use in the Risk Evaluation because common carp represents an edible fish and generally contained the highest HBCD concentrations. Table 2-93 presents the lipid-weight tissue concentrations as reported in ([Chen et al. 2011](#)), and wet-weight concentrations converted from the lipid-weight concentrations using the reported measured lipid content.

Table 2-93. Measured HBCD Concentrations From Various Species and Locations in ([Chen et al. 2011](#))

River	Species	N	Mean Lipid % (median in parentheses)	Mean lipid weight concentrations (ng/g) (median in parentheses)				Mean wet weight conc ^a (ng/g)
				α -	β -	γ -	Σ HBCD	
Hyco (Near-Field)	common carp	7	9% (9%)	4270 (4700)	71 (54)	300 (250)	4640 (5010)	417.6
	channel catfish	2	9% (9%)	3580 (3580)	60 (60)	46 (46)	3680 (3680)	331.2
	redhorse sucker	2	6% (6%)	1340 (1340)	10 (10)	53 (53)	1400 (1400)	84
	gizzard shad	2	9% (9%)	277 (277)	0.5 (0.5)	15 (15)	290 (290)	26.1
Dan (Far-Field 1)	common carp	7	13% (12%)	150 (73)	4.4 (3)	21 (21)	176 (100)	22.88
	channel catfish	9	12% (10%)	145 (111)	1.7 (1)	5 (3)	152 (115)	18.24
	redhorse sucker	3	10% (8%)	14 (15)	<0.2 (0.2)	1.3 (1)	16 (16)	1.6
	flathead catfish	6	13% (11%)	667 (360)	17 (6)	14 (6)	698 (370)	90.74
Roanoke	common carp	7	11% (10%)	38 (32)	1.6 (1)	14 (7.2)	54 (40)	5.94
	channel catfish	5	8% (7%)	58 (56)	0.7 (0.7)	1.9 (1.8)	60 (59)	4.8

River	Species	N	Mean Lipid % (median in parentheses)	Mean lipid weight concentrations (ng/g) (median in parentheses)				Mean wet weight conc ^a (ng/g)
				α-	β-	γ-	ΣHBCD	
(Far-Field 2)	redhorse sucker	8	8% (7%)	18 (17)	0.3 (<0.2)	2.8 (2.6)	21 (20)	1.68
	gizzard shad	5	9% (8%)	10 (9)	0.4 (<0.2)	2.6 (2.4)	13 (12)	1.17

^a Lipid weight concentrations were converted to wet weight concentrations using the reported mean lipid percentage.

These concentrations in ng/g were converted to mg/g and the dietary intake of fish for the subsistence fisher was calculated using a fish ingestion rate of 142.2 g/day (U.S. EPA 2000a). Subsistence fishers rely on fish for their protein intake, so the elevated fish ingestion exposures replaced the entirety of the meat subset of diet. The subsistence fisher diet estimate was aggregated with other exposure pathways in the same manner as was done for the general population (Section 2.4.2.2.5).

Central tendency exposure estimates for subsistence fishers for each exposure pathway and the aggregated total are presented below in Table 2-94, with adult general population included for comparison. The near-field subsistence fisher aggregate exposure is approximately 200-fold higher than the adult general population. Based on reasonably available information, EPA is unable to determine subsistence fisher exposure estimates specific to younger lifestages.

Table 2-94. Aggregate Central Tendency Exposure Comparison for Subsistence Fishers

Group	DIET	DUST	SOIL	AIR	DERMAL	ALL
Adult General Population	1.6E-06	9.7E-07	1.8E-10	1.7E-07	3.1E-07	3.1E-06
Subsistence Fisher NF (Hyco)	7.4E-04	9.7E-07	1.8E-10	1.7E-07	3.1E-07	3.1E-06
Subsistence Fisher FF 1 (Dan)	4.2E-05	9.7E-07	1.8E-10	1.7E-07	3.1E-07	4.3E-05
Subsistence Fisher FF 2 (Roanoke)	1.2E-05	9.7E-07	1.8E-10	1.7E-07	3.1E-07	1.3E-05

All exposure values shown represent mg/kg.

2.4.3 Highly Exposed General Population Exposures

2.4.3.1 Approach and Methodology

In this evaluation, highly-exposed general population include individuals who are expected to live close to facility or residential sources, representing an example of Potentially Exposed or Susceptible Subpopulations (PESS, see Section 2.4.8). EPA identified additional scenarios for the highly-exposed general population, some of which were assessed quantitatively and some of which were assessed qualitatively. This section contains discussion regarding two pathways that were assessed quantitatively: 1. emissions to water and subsequent ingestion of fish tissue (Scenario H1) and 2. emissions to air and subsequent inhalation of particles (Scenario H2). Other scenarios considering exposure to EPS and XPS insulation in buildings during use (Q1) and HBCD sent to landfill across the lifecycle (Q2) were assessed qualitatively and discussed in Section 2.4.5.

Exposure from scenario-specific uses was estimated for emissions to water and air, as depicted in Figure 2-7. For quantitative analysis, exposure was modeled using the scenario-specific release estimates that are summarized in Section 2.3.1. Modeled dust and indoor air concentrations, modeled outdoor air concentrations, modeled water concentrations, and estimated soil, fish, and dietary concentrations will be considered alongside available monitoring data.

Uses	Summary of Release Types	Summary of Media or Pathways	Exposure Scenarios	Media Estimation Methods
Scenario-specific	Emission to water: <ul style="list-style-type: none"> • Surface water • On-site WWT • POTW 	Dietary (Fish) (H1)	<ul style="list-style-type: none"> • Emission factor • Number of release days • Treatment fractional removal • Flow rates 	Water <ul style="list-style-type: none"> • Modeled: E-FAST • Monitored Fish <ul style="list-style-type: none"> • Water & BAF
	Emission to air: <ul style="list-style-type: none"> • Fugitive • Stack • Incinerator 	Air (H2)	<ul style="list-style-type: none"> • Emission factor • Number of release days 	Air <ul style="list-style-type: none"> • Modeled: IIOAC

Figure 2-7. Overview of Exposure Assessment Method for Highly Exposed Scenarios

2.4.3.2 Near Facility Dietary (Fish) — Ingestion

EPA estimated highly exposed fish ingestion using modeled scenario-specific surface water concentrations (point source) plus a lipid normalized upper trophic level fish BAF to convert the surface water concentrations to fish tissue concentrations (Method 1). For comparison, EPA also estimated possible dose ranges using all available fish-tissue monitoring data (Method 2), as well as all surface water monitoring data plus lipid normalized upper trophic level fish BAF (Method 3). While the modeled estimates apply to a smaller population who live near a facility and may ingest fish caught within proximity to the river, the fish ingestion estimates based on monitoring data apply to whatever conditions were present when those samples were taken.

Equations

The equation used to estimate exposure due to fish ingestion when monitored or modeled surface water concentrations are available is presented in Equation 2-20 below. Exposure calculated from fish tissue concentration directly uses the same basic equation, but the fish tissue concentration ($\mu\text{g}/\text{kg}$) is substituted for the surface water concentration and the BAF is removed.

Equation 2-20

$$ADR \text{ or } ADD = \frac{SWC \times BAF \times IR \times CF1 \times CF2 \times ED}{AT}$$

Where

ADR = Acute dose rate used for acute non-cancer risk calculations due to fish ingestion (mg/kg-day)

ADD = Average daily dose used for chronic non-cancer risk calculations due to fish ingestion (mg/kg-day)

SWC = Surface water (dissolved) concentration ($\mu\text{g/L}$)
BAF = Bioaccumulation factor (L/kg)
IR = Age-specific fish ingestion rate (g/kg bw-day)
CF₁ = Conversion factor for $\text{mg}/\mu\text{g}$
CF₂ = Conversion factor for kg/g
ED = Exposure duration (considers near facility residential mobility) (year)
AT = Averaging time (year)

Bioaccumulation factor

The surface water concentrations (measured or modeled) were converted to fish tissue concentrations using a wet weight BAF of 46,488 L/kg determined from the upper trophic level lipid normalized BAF in Wu et al. (2010).

The application of a BAF to measured fish tissue concentrations is not applicable.

Concentrations

Wet weight fish tissue concentrations, converted from surface water concentrations as appropriate, are reported in for each method. The data is described below.

Table 2-95. Summary of HBCD Fish Concentration Data for Estimating Fish Ingestion Dose

Data Approach	Data Description	Surface Water Concentration (ng/L)	Wet Weight Fish Tissue Concentration (mg/kg ww)
Method 1. Modeled Surface Water Concentration ^a	21-day average dissolved water concentrations from PSC modeling using 10 th and 50 th percentile mean flows	Overall range: 6.8E-02 – 3.4E+04	Overall range: 3.6E-03 – 1.6E+03
Method 2. Fish Tissue Monitoring Data (wild-caught) ^b	66 studies with 1774 samples collected from over 27 countries	n/a	Overall range: ND – 1.0E+01 CT range: 2.0E-06 – 4.9E+00
Method 3. Measured Surface Water Concentration ^a	14 studies with 600 samples collected from the following countries: AQ, CA, CN, DK, GB, JP, KR, PL, US, and ZA	Overall range: ND – 3.1E+03 CT range: 4.3E-04 – 3.1E+03	Overall range: ND – 1.4E+02 CT range: 2.0E-05 – 1.4E+02

^a The measured and modeled surface water concentrations were converted to fish tissue concentrations using a low-end lipid normalized upper trophic level fish BAF value of 46,488.

^b If wet weight fish tissue concentrations were not available, lipid-weight fish tissue concentrations were calculated using a generic 5% lipid content.

Method 1. Modeled Scenario Specific Surface Water Concentrations

Specifically, 21-day average dissolved surface water concentrations were obtained from modeling performed using the Variable Volume Waterbody Model (VVWM) - Point Source Calculator (PSC) (U.S. EPA 2019q). A summary of the condition of use scenarios modeled, including release estimates, is described in the Environmental Exposure section (Section 2.3.1). A description of the modeling approach is provided in Section 2.3.2.2.2. For fish ingestion, the modeling used harmonic mean surface water flows which represent long-term average flow conditions. The 50th percentile flow was used to estimate the central ADD and the 10th percentile flow used to estimate the high-end ADD. The 50th percentile harmonic mean flow concentrations ranged from 6.8E-05 to 1.2 $\mu\text{g/L}$ and the 10 percentile

harmonic mean flow concentrations ranged from 1.9E-03 to 3.4 E+01 µg/L. Results by specific subscenario are presented in Appendix G.

Method 2. Measured Fish-Tissue Concentrations

Fish concentrations were reported in the literature on a lipid weight and wet weight basis. Species-specific lipid content as reported by the individual studies, was not collected. Lipid content in fish ranges from <1% to 15% ([U.S. EPA 2011b](#)). To convert from lipid concentration to wet weight concentration, Equation 2-21 is used.

Equation 2-21

$$\mathit{Conc, ww} = \mathit{Conc, lw} \times \frac{\% \mathit{lipid}}{100\%}$$

Where

$\mathit{Conc, ww}$ = Concentration on a wet weight basis, µg/kg ww
 $\mathit{Conc, lw}$ = Concentration on a lipid weight basis, µg/kg lw
 $\% \mathit{lipid}$ = Percentage of fish that is comprised of lipids

EPA used a generic default of 5% lipid content for any monitoring study that only reported fish-tissue data in wet weight and did not provide enough detail on lipid-weight to estimate a lipid weight concentration.

Charts depicting fish-tissue concentrations in all extracted studies are provided in the *Risk Evaluation for Cyclic Aliphatic Bromide Cluster (HBCD), Supplemental Information on General Population, Environmental, and Consumer Exposure Assessment*.

As discussed above, Chen et al. ([2011](#)) provides the best representative U.S. study of fish biomonitoring concentrations. In this study fish samples were collected from three rivers in Virginia and North Carolina in 1999-2002 (n=189) and in 2006-2007 (n=183). The area in general is not industrial or densely populated, but is in an area of textile production. Concentrations in fish varied significantly between the rivers. The highest concentrations were from the Hyco River (maximum mean of 4640 ng/g lw), which the authors hypothesized was because a textile-related facility was located approximately 10 km upstream from the sampling sites. The maximum mean concentrations in the Dan River fish and the Roanoke River fish were lower at 698 and 60 ng/g lw, respectively. The authors hypothesize that levels were higher in the Dan River watershed because the area has traditionally been home to more textiles and furniture operations than the Roanoke watershed. A temporal analysis showed increase in concentrations from 1992-2002 to 2006-2007, which may have been due to the emergence of HBCD point sources in the mid-2000s in this local study. The use of HBCD in textiles is currently considered a historical activity. More recent follow-up studies in this area are not available to investigate current conditions and trends. The study results do indicate higher concentrations near point sources and lower concentrations in diffuse source-derived areas. This is corroborated in the Chen et al. ([2011](#)) meta-analysis of seventeen U.S. and international studies which showed HBCD concentrations were 1 to 2 orders of magnitude higher in freshwater fish sampled near point sources (38 to 6,660 ng/g lw) than in freshwater fish sampled further away from sources (0.1 to 51.5 ng/g lw).

Method 3. Measured Surface Water Concentrations

Charts depicting surface water concentrations in all extracted studies are provided in the *Risk Evaluation*

for Cyclic Aliphatic Bromide Cluster (HBCD), Supplemental Information on General Population, Environmental, and Consumer Exposure Assessment ([U.S. EPA 2019d](#)). As discussed in the Environmental Exposure section, estimated central and high-end concentrations, respectively, were 0.84 and 0.99 µg/L for near facility and 4.1E-04 and 8.0E-04 µg/L for away from facility (see Table 2-56).

Ingestion Rate

EPA used the same fish ingestion rates as for the general population assessment. Specifically, EPA used data from ([U.S. EPA 2014b](#)) along with mean body weights for each age group from ([U.S. EPA 2011b](#)) to calculate a g/kg-day ingestion rate. The high-end or ADR doses were calculated using the high-end fish ingestion rate and the central or ADD doses were calculated using the central fish ingestion rate.

Exposure Duration and Averaging Time

An exposure duration and averaging time of 1 day was used for the acute ADR. For ADD calculation using the modeled scenario-specific data, EPA assumed that children in the highly exposed group live near a facility with elevated concentrations of HBCD for the entire duration of that life stage. EPA assumed that adults in the highly exposed group live near a facility for a portion of their adult life, depending on whether it was high-end or a central tendency estimate. The upper-end estimate for residential mobility is 33 years and was selected for a high-end exposure duration ([U.S. EPA 2011b](#)). For a central tendency estimate for residential mobility, a value of 12 years was selected ([U.S. EPA 2011b](#)). For the other portion of their adult life, it was assumed that they were exposed to central tendency fish-tissue concentration values based on monitoring data. Residential mobility was not factored into the equation for the measured surface water and tissue methods because the values cannot be attributed to a specific point source. For the averaging time, the ADD calculation used the years within an age group.

Results

The central and high-end fish ingestion estimates from the scenario specific surface water modeling are provided in Table 2-96 and Table 2-97 for the array of exposure scenarios and age groups.

Table 2-96. Highly Exposed Group: Range of High-End HBCD Fish Ingestion Dose by Scenario and Age Group (mg/kg/day)

SCENARIO NAME	Infant (<1 yr)	Young Toddler (1-<2 yrs)	Toddler (2-<3 yrs)	Small Child (3-<6 yrs)	Child (6-<11 yrs)	Teen (11-<16 yrs)	Adult (16-<70 yrs)
1. Processing: Repackaging of Import Containers	NA	4.0E-03 - 2.7E-02	3.3E-03 - 2.2E-02	3.0E-03 - 2.0E-02	2.4E-03 - 1.6E-02	1.4E-03 - 9.5E-03	2.7E-03 - 1.8E-02
2. Processing: Compounding of Polystyrene Resin to Produce XPS Masterbatch	NA	3.3E-04 - 5.2E-03	2.7E-04 - 4.3E-03	2.4E-04 - 3.9E-03	1.7E-04 - 3.0E-03	1.0E-04 - 1.8E-03	1.7E-04 - 3.4E-03
3. Processing: Manufacturing of XPS Foam using XPS Masterbatch	NA	1.6E-04 - 1.8E-02	1.3E-04 - 1.5E-02	1.0E-04 - 1.3E-02	7.1E-05 - 1.0E-02	3.9E-05 - 6.3E-03	4.9E-05 - 1.2E-02
4. Processing: Manufacturing of XPS Foam Using HBCD Powder	NA	1.6E-04 - 7.0E-03	1.4E-04 - 5.8E-03	1.1E-04 - 5.3E-03	7.6E-05 - 4.1E-03	4.2E-05 - 2.5E-03	5.5E-05 - 4.6E-03
5. Processing: Manufacturing of EPS Foam from Imported EPS Resin Beads	NA	3.8E-02 - 6.5E-01	3.2E-02 - 5.4E-01	2.9E-02 - 4.9E-01	2.3E-02 - 3.8E-01	1.4E-02 - 2.3E-01	2.6E-02 - 4.4E-01
6. Processing: Manufacturing of SIPs and Automobile Replacement Parts from XPS/EPS Foam	NA	3.2E-04 - 9.9E-03	2.7E-04 - 8.2E-03	2.3E-04 - 7.4E-03	1.7E-04 - 5.8E-03	9.9E-05 - 3.5E-03	1.6E-04 - 6.6E-03

SCENARIO NAME	Infant (<1 yr)	Young Toddler (1-<2 yrs)	Toddler (2-<3 yrs)	Small Child (3-<6 yrs)	Child (6-<11 yrs)	Teen (11-<16 yrs)	Adult (16-<70 yrs)
7. Use: Installation of Automobile Replacement Parts	No water releases						
8. Use: Installation of XPS/EPS Foam Insulation in Residential, Public and Commercial Buildings, and other Structures	NA	5.3E-04 - 5.3E-03	4.4E-04 - 4.4E-03	4.0E-04 - 4.0E-03	3.1E-04 - 3.1E-03	1.9E-04 - 1.9E-03	3.6E-04 - 3.6E-03
9. Demolition and Disposal of Insulation in Buildings	NA	3.6E-03 - 3.6E-02	2.9E-03 - 2.9E-02	2.7E-03 - 2.7E-02	2.1E-03 - 2.1E-02	1.3E-03 - 1.3E-02	2.4E-03 - 2.4E-02
10. Processing: Recycling of EPS Foam	NA	6.2E-04 - 1.2E-02	5.1E-04 - 9.8E-03	4.5E-04 - 9.0E-03	3.4E-04 - 7.0E-03	2.0E-04 - 4.2E-03	3.6E-04 - 8.0E-03
11. Processing: Formulation of Coatings and solder	No water releases						
12. Use of Solder	NA	1.4E-04 - 1.9E-04	1.2E-04 - 1.6E-04	9.4E-05 - 1.3E-04	6.3E-05 - 9.1E-05	3.5E-05 - 5.1E-05	4.0E-05 - 7.2E-05

Table 2-97. Highly Exposed Group: Range of Central HBCD Fish Ingestion by Scenario and Age Group (mg/kg/day)

SCENARIO NAME	Infant (<1 yr)	Young Toddler (1-<2 yrs)	Toddler (2-<3 yrs)	Small Child (3-<6 yrs)	Child (6-<11 yrs)	Teen (11-<16 yrs)	Adult (16-<70 yrs)		
							HE	CT	
1. Processing: Repackaging of Import Containers	NA	1.7E-05 - 4.8E-04	1.4E-05 - 3.9E-04	1.2E-05 - 3.4E-04	1.1E-05 - 3.1E-04	6.3E-06 - 1.8E-04	4.5E-06 - 1.3E-04	1.2E-05 - 3.5E-04	
2. Processing: Compounding of Polystyrene Resin to Produce XPS Masterbatch	NA	1.0E-06 - 2.2E-05	8.3E-07 - 1.9E-05	7.2E-07 - 1.6E-05	6.6E-07 - 1.5E-05	3.7E-07 - 8.2E-06	2.7E-07 - 5.9E-06	7.3E-07 - 1.6E-05	
3. Processing: Manufacturing of XPS Foam using XPS Masterbatch	NA	2.2E-07 - 7.9E-05	1.8E-07 - 6.5E-05	1.5E-07 - 5.7E-05	1.4E-07 - 5.2E-05	8.0E-08 - 2.9E-05	5.8E-08 - 2.1E-05	1.6E-07 - 5.8E-05	
4. Processing: Manufacturing of XPS Foam Using HBCD Powder	NA	2.6E-07 - 3.1E-05	2.1E-07 - 2.6E-05	1.9E-07 - 2.2E-05	1.7E-07 - 2.0E-05	9.5E-08 - 1.1E-05	6.9E-08 - 8.2E-06	1.9E-07 - 2.3E-05	
5. Processing: Manufacturing of EPS Foam from Imported EPS Resin Beads	NA	1.7E-04 - 2.8E-03	1.4E-04 - 2.3E-03	1.2E-04 - 2.0E-03	1.1E-04 - 1.9E-03	6.1E-05 - 1.0E-03	4.4E-05 - 7.5E-04	1.2E-04 - 2.1E-03	
6. Processing: Manufacturing of SIPs and Automobile Replacement Parts from XPS/EPS Foam	NA	9.5E-07 - 4.3E-05	7.9E-07 - 3.5E-05	6.8E-07 - 3.0E-05	6.3E-07 - 2.8E-05	3.5E-07 - 1.6E-05	2.5E-07 - 1.1E-05	7.0E-07 - 3.1E-05	
7. Use: Installation of Automobile Replacement Parts	No water releases								
8. Use: Installation of XPS/EPS Foam Insulation in Residential, Public and Commercial Buildings, and other Structures	NA	6.9E-06 - 6.9E-05	5.7E-06 - 5.7E-05	5.0E-06 - 5.0E-05	4.6E-06 - 4.6E-05	2.5E-06 - 2.5E-05	1.8E-06 - 1.8E-05	5.1E-06 - 5.1E-05	
9. Demolition and Disposal of Insulation in Buildings	NA	4.7E-05 - 4.7E-04	3.9E-05 - 3.9E-04	3.3E-05 - 3.3E-04	3.1E-05 - 3.1E-04	1.7E-05 - 1.7E-04	1.2E-05 - 1.2E-04	3.4E-05 - 3.4E-04	
10. Processing: Recycling of EPS Foam	NA	2.2E-06 - 5.3E-05	1.8E-06 - 4.4E-05	1.6E-06 - 3.8E-05	1.5E-06 - 3.5E-05	8.2E-07 - 1.9E-05	5.9E-07 - 1.4E-05	1.6E-06 - 3.9E-05	

SCENARIO NAME	Infant (<1 yr)	Young Toddler (1-<2 yrs)	Toddler (2-<3 yrs)	Small Child (3-<6 yrs)	Child (6-<11 yrs)	Teen (11-<16 yrs)	Adult (16-<70 yrs)	
							HE	CT
11. Processing: Formulation of Coatings and solder	No water releases							
12. Use of Solder	NA	1.7E-07 - 1.5E-06	1.4E-07 - 1.3E-06	1.2E-07 - 1.1E-06	1.1E-07 - 1.0E-06	6.1E-08 - 5.6E-07	4.4E-08 - 4.0E-07	1.2E-07 - 1.1E-06

Figure 2-8 compares the adult fish ingestion doses from the scenario-specific modeled surface water concentrations with adult fish ingestion doses calculated from measured fish tissue concentrations and surface water concentrations obtained from literature. The subsistence fisher doses presented in Section 2.4.2 using the (Chen et al. 2011) fish tissue concentrations and a higher fish ingestion rate are also shown. The scenario-specific doses are higher, but are generally within an order of magnitude of doses calculated from the measured fish tissue or surface water concentrations.

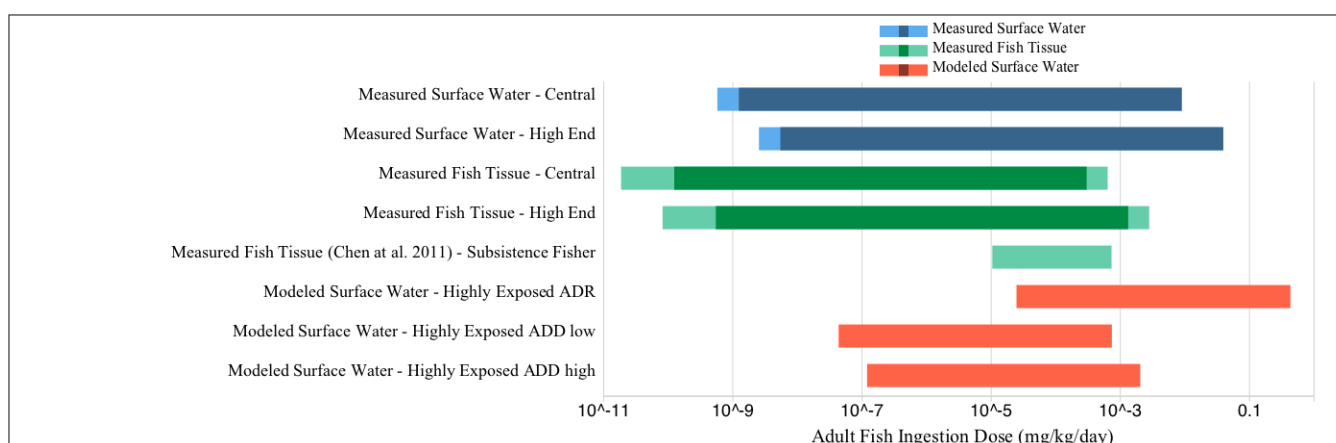

Figure 2-8. Comparison of Potential HBCD Fish Ingestion Dose based on Modeled Surface Water Concentrations, Fish Tissue Monitoring Data, and Surface Water Monitoring Data.

The lighter shade represents the range of all reported values, whereas the darker shade represents the range of only central tendency reported values.

2.4.3.3 Near Facility Suspended Particulates in Air — Inhalation

EPA derived scenario-specific near-facility ambient and indoor air concentrations of HBCD using its Integrated Indoor and Outdoor Air Calculator (IIOAC) tool, based on AERMOD results from a suite of dispersion scenarios. Under each scenario from Section 2.2, multiple model runs were performed to include different source types and high-end and central tendency release estimates. For scenarios with site-specific information, this information was used in the IIOAC model runs to determine the meteorological station and population setting. When site-specific information was not known, representative central tendency and high-end meteorological stations were used, along with other default parameters (see Appendix G). For a given exposure scenario, a range of estimated air concentrations was derived for each source type (fugitive, stack, incineration) at the fence line and in the community. Fence line estimates were defined as air concentrations at 100-meter from the source while community-averaged estimates were defined as average air concentrations within 100 to 1,000-meter from the facility. EPA derived scenario-specific near-facility ambient and indoor air concentrations of HBCD using its Integrated Indoor and Outdoor Air Calculator (IIOAC) tool, based on AERMOD results from a suite of dispersion scenarios. Under each scenario from Section 2.2, multiple model runs were

performed to include different source types and high-end and central tendency release estimates. For scenarios with site-specific information, this information was used in the IIOAC model runs to determine the meteorological station and population setting. When site-specific information was not known, representative central tendency and high-end meteorological stations were used, along with other default parameters (see Appendix G). For a given exposure scenario, a range of estimated air concentrations was derived for each source type (fugitive, stack, incineration) at the fenceline and in the community. Fenceline estimates were defined as air concentrations at 100-meter from the source while community-averaged estimates were defined as average air concentrations within 100 to 1,000-meter from the facility.

The range of modeled daily-averaged and annual-averaged results are presented in Table 2-98 for an averaged indoor and outdoor air concentration by scenario and source type. Across all scenarios, the average air concentration ranged from 1.5×10^{-8} to $11.3 \mu\text{g}/\text{m}^3$ for fugitive sources, 4.70×10^{-7} to $2.9 \mu\text{g}/\text{m}^3$ for stack sources, and 9.5×10^{-7} to $0.50 \mu\text{g}/\text{m}^3$ for incinerator sources. Ambient air concentrations were modeled in IIOAC and averaged together with indoor air concentrations using the fraction of the day spent outdoors, which was informed by the EPA's Consolidated Human Activity Patterns Database ([U.S. EPA 2009b](#)). Indoor air concentrations were estimated using an indoor/outdoor ratio of 0.95 for high-end estimates and 0.65 for central tendency estimates ([U.S. EPA 2019r](#)). When a choice was available for central tendency or high-end average air concentrations, high-end fenceline results were used for daily-averaged air concentrations and central tendency community-averaged results were used for annual-averaged concentrations. For scenarios without site-specific information, IIOAC runs were performed using both the representative central tendency and the high-end meteorological stations. In these cases, the maximum high-end daily fenceline air concentration and the minimum mean community-averaged annual air concentration are presented in Table 2-98.

Table 2-98. Overall Summary of HBCD Averaged Indoor and Outdoor Air Concentrations for 12 Emission Scenarios

Scenario Name	Fugitive Air Concentration Range ($\mu\text{g}/\text{m}^3$)	Stack Air Concentration Range ($\mu\text{g}/\text{m}^3$)	Incineration Air Concentration Range ($\mu\text{g}/\text{m}^3$)
	24-Hour Average / Yearly Average	24-Hour Average / Yearly Average	24-Hour Average / Yearly Average
1. Processing: Repackaging of Import Containers	6.7E-02 - 5.9E+00 / 8.7E-04 - 4.4E-03	1.2E-02 - 8.5E-01 / 6.7E-04 - 3.4E-03	3.3E-04 - 3.2E-02 / 2.6E-04 - 1.3E-03
2. Processing: Compounding of Polystyrene Resin to Produce XPS Masterbatch	3.4E-03 - 2.6E-02 / 5.4E-06 - 6.4E-06	4.9E-04 - 3.8E-03 / 4.1E-06 - 4.9E-06	NA
3. Processing: Manufacturing of XPS Foam using XPS Masterbatch	1.3E-01 - 2.8E+00 / 5.1E-05 - 5.1E-05	1.9E-02 - 3.5E-01 / 3.9E-05 - 3.9E-05	NA
4. Processing: Manufacturing of XPS Foam Using HBCD Powder	1.6E-02 - 3.5E-01 / 6.4E-06 - 6.4E-06	2.3E-03 - 2.9E+00 / 4.9E-06 - 3.5E-04	6.8E-03 - 2.3E-01 / 1.8E-04 - 1.9E-04
5. Processing: Manufacturing of EPS Foam from Imported EPS Resin Beads	2.0E-01 - 1.1E+01 / 8.7E-04 - 4.4E-03	3.2E-02 - 1.6E+00 / 6.7E-04 - 3.4E-03	2.1E-02 - 5.0E-01 / 5.4E-03 - 1.0E-02
6. Processing: Manufacturing of SIPs and Automobile Replacement Parts from XPS/EPS Foam	3.4E-03 - 5.1E-01 / 4.4E-05 - 2.0E-04	5.9E-04 - 7.2E-02 / 3.4E-05 - 1.5E-04	3.3E-03 - 3.1E-01 / 2.6E-03 - 6.5E-03

Scenario Name	Fugitive Air Concentration Range ($\mu\text{g}/\text{m}^3$) 24-Hour Average / Yearly Average	Stack Air Concentration Range ($\mu\text{g}/\text{m}^3$) 24-Hour Average / Yearly Average	Incineration Air Concentration Range ($\mu\text{g}/\text{m}^3$) 24-Hour Average / Yearly Average
7. Use: Installation of Automobile Replacement Parts	NA	NA	NA
8. Use: Installation of XPS/EPS Foam Insulation in Residential, Public and Commercial Buildings, and other Structures	9.0E-04 - 8.9E-02 / 1.6E-08 - 5.8E-06	NA	1.4E-03 - 6.6E-02 / 9.5E-07 - 1.9E-04
9. Demolition and Disposal of XPS/EPA Foam Insulation Products in Residential, Public and Commercial Buildings, and Other Structures	8.0E-04 - 7.1E-01 / 1.5E-08 - 1.3E-05	NA	NA
10. Processing: Recycling of EPS Foam and Reuse of XPS Foam	1.4E-04 - 1.7E-01 / 6.1E-07 - 3.1E-06	2.2E-05 - 2.1E-02 / 4.7E-07 - 2.3E-06	1.5E-05 - 5.9E-03 / 3.8E-06 - 4.5E-06
11. Processing: Formulation of Flux/Solder Pastes	2.9E-04 - 3.1E-02 / 6.6E-06 - 6.7E-06	1.9E-03 - 1.6E-01 / 7.5E-05 - 7.6E-05	NA
12. Use of Flux/Solder Pastes	NA	NA	5.8E-06 - 1.2E-03 / 4.5E-06 - 5.1E-06

Gray cells indicate no release data for this source.

The range of acute dose rate (ADR) and average daily dose (ADD) are presented in Table 2-99 and Table 2-100, respectively, by scenario and age group. ADR and ADD were calculated using the average air concentrations from Equation 2-22, and with a conservative assumption that 100% of inhaled particles are ingested. The daily-averaged and annual-averaged air concentrations were used to calculate the ADR and ADD, respectively. EPA used the Exposure Factors Handbook ([U.S. EPA 2011b](#)) to inform age-specific body weights and inhalation rates. Specific exposure factors are provided in Appendix G. Across all scenarios, COU 5 (Manufacturing of EPS Foam from Imported EPS Resin Beads) resulted in the highest ADR values for all age groups, with infants having the maximum ADR. Similarly, COU 5 also resulted in the highest ADD values for all age groups, with young toddlers having the maximum ADD.

Equation 2-22

$$ADD \text{ or } ADR = \frac{AC \times InhR \times CF_1 \times ED}{BW \times AT}$$

Where

ADD = Average daily dose (mg/kg-day)

ADR = Acute dose rate (mg/kg-day)

AC = Average air concentration ($\mu\text{g}/\text{m}^3$), daily-averaged air concentration for ADR and annual-averaged air concentration for ADD

InhR = Inhalation rate, in m^3/hr for ADR and m^3/day for ADD

CF₁ = Conversion factor from mg to μg

ED = Exposure duration, in days for ADR and years for ADD

BW = Body weight (kg)

AT = Averaging time, in days for ADR and years for ADD

Table 2-99. Highly Exposed Group: Range of HBCD Inhalation Dose by Scenario and Age Group, Acute Dose Rate (mg/kg/day)

SCENARIO NAME	Infant (<1 yr)	Young Toddler (1-<2 yrs)	Toddler (2-<3 yrs)	Small Child (3-<6 yrs)	Child (6-<11 yrs)	Teen (11-<16 yrs)	Adult (16-<70 yrs)
1. Processing: Repackaging of Import Containers	3.8E-07 – 6.9E-03	3.7E-07 - 6.6E-03	3.3E-07 - 5.8E-03	2.4E-07 - 4.3E-03	1.7E-07 - 3.1E-03	1.3E-07 - 2.3E-03	8.6E-08 - 1.5E-03
2. Processing: Compounding of Polystyrene Resin to Produce XPS Masterbatch	5.8E-07 - 3.1E-05	5.5E-07 - 3.0E-05	4.9E-07 - 2.6E-05	3.6E-07 - 2.0E-05	2.6E-07 - 1.4E-05	1.9E-07 - 1.0E-05	1.3E-07 - 7.0E-06
3. Processing: Manufacturing of XPS Foam using XPS Masterbatch	2.2E-05 - 3.3E-03	2.1E-05 - 3.1E-03	1.8E-05 - 2.7E-03	1.4E-05 - 2.1E-03	9.7E-06 - 1.4E-03	7.1E-06 - 1.1E-03	4.9E-06 – 7.3E-04
4. Processing: Manufacturing of XPS Foam Using HBCD Powder	2.7E-06 - 3.4E-03	2.6E-06 - 3.3E-03	2.3E-06 - 2.9E-03	1.7E-06 - 2.1E-03	1.2E-06 - 1.5E-03	9.0E-07 - 1.1E-03	6.1E-07 – 7.6E-04
5. Processing: Manufacturing of EPS Foam from Imported EPS Resin Beads	2.5E-05 - 1.3E-02	2.4E-05 - 1.3E-02	2.1E-05 - 1.1E-02	1.6E-05 - 8.4E-03	1.1E-05 - 5.9E-03	8.1E-06 - 4.3E-03	5.5E-06 - 3.0E-03
6. Processing: Manufacturing of SIPs and Automobile Replacement Parts from XPS/EPS Foam	7.0E-07 - 6.0E-04	6.7E-07 - 5.7E-04	5.9E-07 - 5.0E-04	4.4E-07 - 3.8E-04	3.1E-07 - 2.6E-04	2.3E-07 - 2.0E-04	1.6E-07 - 1.3E-04
7. Use: Installation of Automobile Replacement Parts	No releases						
8. Use: Installation of XPS/EPS Foam Insulation in Residential, Public and Commercial Buildings, and other Structures	1.1E-06 - 1.0E-04	1.0E-06 - 1.0E-04	8.9E-07 – 8.9E-05	6.7E-07 - 6.6E-05	4.7E-07 - 4.7E-05	3.5E-07 - 3.4E-05	2.4E-07 - 2.4E-05
9. Demolition and Disposal of XPS/EPS Foam Insulation Products in Residential, Public and Commercial Buildings, and Other Structures	9.4E-07 – 8.4E-04	9.0E-07 - 8.0E-04	7.9E-07 – 7.1E-04	5.9E-07 – 5.3E-04	4.2E-07 - 3.7E-04	3.1E-07 – 2.7E-04	2.1E-07 – 1.9E-04
10. Processing: Recycling of EPS Foam and Reuse of XPS Foam	1.7E-08 - 2.0E-04	1.6E-08 - 1.9E-04	1.5E-08 - 1.7E-04	1.1E-08 - 1.2E-04	7.7E-09 - 8.7E-05	5.7E-09 - 6.5E-05	3.9E-09 - 4.4E-05
11. Processing: Formulation of Flux/Solder Pastes	3.4E-07 - 1.9E-04	3.3E-07 - 1.8E-04	2.9E-07 - 1.6E-04	2.2E-07 - 1.2E-04	1.5E-07 - 8.5E-05	1.1E-07 - 6.3E-05	7.7E-08 - 4.3E-05
12. Use of Flux/Solder Pastes	6.8E-09 - 1.4E-06	6.5E-09 - 1.4E-06	5.7E-09 - 1.2E-06	4.3E-09 - 9.1E-07	3.0E-09 - 6.4E-07	2.2E-09 - 4.7E-07	1.5E-09 - 3.2E-07

Table 2-100. Range of HBCD Inhalation Dose by Scenario and Age Group, Average Daily Dose (mg/kg/day)

SCENARIO NAME	Infant (<1 yr)	Young Toddler (1-<2 yrs)	Toddler (2-<3 yrs)	Small Child (3-<6 yrs)	Child (6-<11 yrs)	Teen (11-<16 yrs)	Adult (16-<70 yrs)	
							HE	CT
1. Processing: Repackaging of Import Containers	1.8E-07 - 3.0E-06	1.8E-07 - 3.1E-06	1.6E-07 - 2.8E-06	1.4E-07 - 2.4E-06	9.6E-08 - 1.7E-06	6.8E-08 - 1.2E-06	3.0E-08 - 5.3E-07	1.1E-08 - 1.9E-07
2. Processing: Compounding of Polystyrene Resin to Produce XPS Masterbatch	2.8E-09 - 4.4E-09	2.9E-09 - 4.5E-09	2.6E-09 - 4.1E-09	2.2E-09 - 3.5E-09	1.5E-09 - 2.4E-09	1.1E-09 - 1.7E-09	4.9E-10 - 7.6E-10	1.8E-10 - 2.8E-10
3. Processing: Manufacturing of XPS Foam using XPS Masterbatch	2.7E-08 - 3.5E-08	2.7E-08 - 3.5E-08	2.5E-08 - 3.3E-08	2.1E-08 - 2.7E-08	1.5E-08 - 1.9E-08	1.0E-08 - 1.4E-08	4.6E-09 - 6.0E-09	1.7E-09 - 2.2E-09
4. Processing: Manufacturing of XPS Foam Using HBCD Powder	3.3E-09 - 2.4E-07	3.4E-09 - 2.4E-07	3.1E-09 - 2.2E-07	2.6E-09 - 1.9E-07	1.8E-09 - 1.3E-07	1.3E-09 - 9.3E-08	5.8E-10 - 4.1E-08	2.1E-10 - 1.5E-08
5. Processing: Manufacturing of EPS Foam from Imported EPS Resin Beads	4.6E-07 - 7.1E-06	4.7E-07 - 7.2E-06	4.3E-07 - 6.6E-06	3.6E-07 - 5.6E-06	2.5E-07 - 3.9E-06	1.8E-07 - 2.7E-06	7.9E-08 - 1.2E-06	2.9E-08 - 4.4E-07
6. Processing: Manufacturing of SIPs and Automobile Replacement Parts from XPS/EPS Foam	2.3E-08 - 4.4E-06	2.4E-08 - 4.5E-06	2.2E-08 - 4.2E-06	1.8E-08 - 3.5E-06	1.3E-08 - 2.4E-06	9.0E-09 - 1.7E-06	4.0E-09 - 7.7E-07	1.5E-09 - 2.8E-07
7. Use: Installation of Automobile Replacement Parts	No releases							
8. Use: Installation of XPS/EPS Foam Insulation in Residential, Public and Commercial Buildings, and other Structures	1.1E-11 - 1.3E-07	1.1E-11 - 1.3E-07	1.1E-11 - 1.2E-07	8.9E-12 - 1.0E-07	6.2E-12 - 7.1E-08	4.4E-12 - 5.0E-08	2.0E-12 - 2.2E-08	7.1E-13 - 8.1E-09
9. Demolition and Disposal of XPS/EPS Foam Insulation Products in Residential, Public and Commercial Buildings, and Other Structures	1.0E-11 - 9.0E-09	1.0E-11 - 9.1E-09	9.4E-12 - 8.4E-09	7.9E-12 - 7.1E-09	5.5E-12 - 4.9E-09	3.9E-12 - 3.5E-09	1.7E-12 - 1.5E-09	6.3E-13 - 5.6E-10
10. Processing: Recycling of EPS Foam and Reuse of XPS Foam	3.2E-10 - 3.1E-09	3.3E-10 - 3.1E-09	3.0E-10 - 2.9E-09	2.5E-10 - 2.4E-09	1.8E-10 - 1.7E-09	1.2E-10 - 1.2E-09	5.6E-11 - 5.3E-10	2.0E-11 - 1.9E-10
11. Processing: Formulation of Flux/Solder Pastes	4.6E-09 - 5.3E-08	4.6E-09 - 5.3E-08	4.3E-09 - 4.9E-08	3.6E-09 - 4.1E-08	2.5E-09 - 2.9E-08	1.8E-09 - 2.0E-08	7.9E-10 - 9.1E-09	2.9E-10 - 3.3E-09
12. Use of Flux/Solder Pastes	3.1E-09 - 3.5E-09	3.2E-09 - 3.6E-09	2.9E-09 - 3.3E-09	2.4E-09 - 2.8E-09	1.7E-09 - 1.9E-09	1.2E-09 - 1.4E-09	5.4E-10 - 6.0E-10	2.0E-10 - 2.2E-10

2.4.3.4 Aggregate Highly Exposed Population Exposure and Dose

Aggregate doses were calculated for the highly exposed population by summing the central tendency general population dose pathways with the highly exposed dose pathway. Specifically, the aggregate dose for Scenario H1 is the sum of the highly exposed fish ingestion dose and all other central tendency general population non-fish dose pathways. This calculation was not made for infants because infants are not expected to ingest fish in their diet. For further discussion of risks from highly exposed fish ingestion for infants and other lifestages, see Section 4.2.3.2. For Scenario H2, the aggregate dose is the sum of the highly exposed inhalation dose and all other central tendency general population non-inhalation dose pathways.

Table 2-101 and Table 2-102 show a summary of the ADR and ADR aggregate dose estimates for Scenario H1, respectively. Table 2-103 and Table 2-104 show a summary of the ADR and ADR aggregate dose estimates for Scenario H2, respectively.

Table 2-101. Range of HBCD Aggregate Exposure Acute Dose Rate (mg/kg/day) - Background and Modeled Fish Dose by Scenario and Age

SCENARIO NAME	Infant (<1 yr)	Young Toddler (1-<2 yrs)	Toddler (2-<3 yrs)	Small Child (3-<6 yrs)	Child (6-<11 yrs)	Teen (11-<16 yrs)	Adult (16-<70 yrs)
1. Import/Repackaging	n/a	4.0E-03 - 2.7E-02	3.3E-03 - 2.2E-02	3.0E-03 - 2.0E-02	2.3E-03 - 1.6E-02	1.4E-03 - 9.5E-03	2.6E-03 - 1.8E-02
2. Compounding of Polystyrene Resin to Produce XPS Masterbatch	n/a	2.6E-04 - 5.1E-03	2.1E-04 - 4.2E-03	1.8E-04 - 3.9E-03	1.4E-04 - 3.0E-03	8.5E-05 - 1.8E-03	1.6E-04 - 3.4E-03
3. Manufacturing of XPS Foam using XPS Masterbatch	n/a	7.9E-05 - 1.8E-02	5.9E-05 - 1.5E-02	5.1E-05 - 1.3E-02	3.8E-05 - 1.0E-02	2.2E-05 - 6.3E-03	3.6E-05 - 1.2E-02
4. Manufacturing of XPS Foam using HBCD Powder	n/a	8.8E-05 - 6.9E-03	6.7E-05 - 5.7E-03	5.8E-05 - 5.2E-03	4.3E-05 - 4.0E-03	2.5E-05 - 2.4E-03	4.3E-05 - 4.6E-03
5. Manufacturing of EPS Foam from Imported EPS Resin Beads	n/a	3.8E-02 - 6.5E-01	3.2E-02 - 5.4E-01	2.9E-02 - 4.9E-01	2.3E-02 - 3.8E-01	1.4E-02 - 2.3E-01	2.6E-02 - 4.4E-01
6. Manufacturing of SIPs and Automobile Replacement Parts	n/a	2.5E-04 - 9.8E-03	2.0E-04 - 8.1E-03	1.8E-04 - 7.4E-03	1.4E-04 - 5.7E-03	8.2E-05 - 3.5E-03	1.5E-04 - 6.6E-03
7. Installation of Automobile Replacement Parts	No water releases						
8. Installation of XPS/EPS Foam Insulation in Residential, Public, and Commercial Buildings, and Other Structures	n/a	5.6E-04 - 5.4E-03	4.6E-04 - 4.4E-03	4.2E-04 - 4.0E-03	3.2E-04 - 3.1E-03	1.9E-04 - 1.9E-03	3.6E-04 - 3.6E-03
9. Demolition and Disposal of XPS/EPS Foam Insulation in Residential, Public and Commercial Buildings, and Other Structures	n/a	3.6E-03 - 3.6E-02	3.0E-03 - 2.9E-02	2.7E-03 - 2.7E-02	2.1E-03 - 2.1E-02	1.3E-03 - 1.3E-02	2.4E-03 - 2.4E-02
10. Recycling of EPS Foam	n/a	5.4E-04 - 1.2E-02	4.4E-04 - 9.8E-03	4.0E-04 - 8.9E-03	3.1E-04 - 6.9E-03	1.9E-04 - 4.2E-03	3.5E-04 - 7.9E-03
11. Formulation of Solder	No water releases						
12. Use of Solder	n/a	6.6E-05 - 1.1E-04	4.9E-05 - 8.7E-05	4.2E-05 - 7.6E-05	3.0E-05 - 5.7E-05	1.8E-05 - 3.4E-05	2.8E-05 - 5.9E-05

Table 2-102. Range of HBCD Aggregate Exposure Average Daily Dose (mg/kg/day): Background and Modeled Fish Dose by Scenario and Age

SCENARIO NAME	Infant (<1 yr)	Young Toddler (1-<2 yrs)	Toddler (2-<3 yrs)	Small Child (3-<6 yrs)	Child (6-<11 yrs)	Teen (11-<16 yrs)	Adult (16-<70 yrs) - CT	Adult (16-<70 yrs) - HE
1. Import/Repackaging	n/a	4.6E-05 - 5.1E-04	3.2E-05 - 4.1E-04	2.6E-05 - 3.6E-04	2.0E-05 - 3.2E-04	1.1E-05 - 1.8E-04	7.5E-06 - 1.3E-04	1.5E-05 - 3.5E-04
2. Compounding of Polystyrene Resin to Produce XPS Masterbatch	n/a	3.0E-05 - 5.2E-05	1.9E-05 - 3.7E-05	1.4E-05 - 2.9E-05	9.1E-06 - 2.3E-05	4.7E-06 - 1.3E-05	3.2E-06 - 8.9E-06	3.7E-06 - 1.9E-05
3. Manufacturing of XPS Foam using XPS Masterbatch		2.9E-05 - 1.1E-04	1.8E-05 - 8.4E-05	1.4E-05 - 7.0E-05	8.6E-06 - 6.1E-05	4.4E-06 - 3.3E-05	3.0E-06 - 2.4E-05	3.1E-06 - 6.1E-05

SCENARIO NAME	Infant (<1 yr)	Young Toddler (1-<2 yrs)	Toddler (2-<3 yrs)	Small Child (3-<6 yrs)	Child (6-<11 yrs)	Teen (11-<16 yrs)	Adult (16-<70 yrs) - CT	Adult (16-<70 yrs) - HE
4. Manufacturing of XPS Foam using HBCD Powder	n/a	2.9E-05 - 6.0E-05	1.8E-05 - 4.4E-05	1.4E-05 - 3.6E-05	8.6E-06 - 2.9E-05	4.4E-06 - 1.6E-05	3.0E-06 - 1.1E-05	3.1E-06 - 2.6E-05
5. Manufacturing of EPS Foam from Imported EPS Resin Beads	n/a	2.0E-04 - 2.9E-03	1.6E-04 - 2.4E-03	1.3E-04 - 2.0E-03	1.2E-04 - 1.9E-03	6.5E-05 - 1.0E-03	4.7E-05 - 7.6E-04	1.2E-04 - 2.1E-03
6. Manufacturing of SIPs and Automobile Replacement Parts	n/a	3.0E-05 - 7.2E-05	1.9E-05 - 5.3E-05	1.4E-05 - 4.4E-05	9.1E-06 - 3.6E-05	4.6E-06 - 2.0E-05	3.2E-06 - 1.4E-05	3.7E-06 - 3.4E-05
7. Installation of Automobile Replacement Parts	No water releases							
8. Installation of XPS/EPS Foam Insulation in Residential, Public, and Commercial Buildings, and Other Structures	n/a	3.6E-05 - 9.8E-05	2.4E-05 - 7.5E-05	1.8E-05 - 6.3E-05	1.3E-05 - 5.4E-05	6.8E-06 - 3.0E-05	4.8E-06 - 2.1E-05	8.0E-06 - 5.4E-05
9. Demolition and Disposal of XPS/EPS Foam Insulation in Residential, Public and Commercial Buildings, and Other Structures	n/a	7.6E-05 - 5.0E-04	5.7E-05 - 4.0E-04	4.7E-05 - 3.5E-04	3.9E-05 - 3.2E-04	2.1E-05 - 1.8E-04	1.5E-05 - 1.3E-04	3.7E-05 - 3.4E-04
10. Recycling of EPS Foam	n/a	3.1E-05 - 8.2E-05	2.0E-05 - 6.2E-05	1.5E-05 - 5.1E-05	9.9E-06 - 4.3E-05	5.1E-06 - 2.4E-05	3.5E-06 - 1.7E-05	4.6E-06 - 4.2E-05
11. Formulation of Solder	No water releases							
12. Use of Solder	n/a	2.9E-05 - 3.1E-05	1.8E-05 - 1.9E-05	1.4E-05 - 1.4E-05	8.6E-06 - 9.5E-06	4.4E-06 - 4.9E-06	3.0E-06 - 3.4E-06	3.1E-06 - 4.1E-06

Table 2-103. Range of HBCD Aggregate Exposure Acute Dose Rate (mg/kg/day): Background and Modeled Inhalation Dose by Scenario and Age

SCENARIO NAME	Infant (<1 yr)	Young Toddler (1-<2 yrs)	Toddler (2-<3 yrs)	Small Child (3-<6 yrs)	Child (6-<11 yrs)	Teen (11-<16 yrs)	Adult (16-<70 yrs)	
1. Import/Repackaging	4.0E-05 - 6.9E-03	2.9E-05 - 6.6E-03	1.8E-05 - 5.8E-03	1.3E-05 - 4.4E-03	8.4E-06 - 3.1E-03	4.2E-06 - 2.3E-03	3.0E-06 - 1.5E-03	
2. Compounding of Polystyrene Resin to Produce XPS Masterbatch	4.0E-05 - 7.0E-05	2.9E-05 - 5.8E-05	1.8E-05 - 4.4E-05	1.3E-05 - 3.3E-05	8.5E-06 - 2.2E-05	4.3E-06 - 1.4E-05	3.0E-06 - 9.9E-06	
3. Manufacturing of XPS Foam using XPS Masterbatch	6.1E-05 - 3.3E-03	4.9E-05 - 3.1E-03	3.6E-05 - 2.8E-03	2.7E-05 - 2.1E-03	1.8E-05 - 1.5E-03	1.1E-05 - 1.1E-03	7.8E-06 - 7.3E-04	
4. Manufacturing of XPS Foam using HBCD Powder	4.2E-05 - 3.4E-03	3.1E-05 - 3.3E-03	2.0E-05 - 2.9E-03	1.5E-05 - 2.2E-03	9.4E-06 - 1.5E-03	5.0E-06 - 1.1E-03	3.5E-06 - 7.7E-04	
5. Manufacturing of EPS Foam from Imported EPS Resin Beads	6.4E-05 - 1.33E-02	5.2E-05 - 1.3E-02	3.8E-05 - 1.1E-02	2.9E-05 - 8.4E-03	1.9E-05 - 5.9E-03	1.2E-05 - 4.4E-03	8.4E-06 - 3.0E-03	
6. Manufacturing of SIPs and Automobile Replacement Parts	4.0E-05 - 6.4E-04	2.9E-05 - 6.0E-04	1.8E-05 - 5.2E-04	1.3E-05 - 3.9E-04	8.5E-06 - 2.7E-04	4.3E-06 - 2.0E-04	3.1E-06 - 1.4E-04	
7. Installation of Automobile Replacement Parts	No air releases							

SCENARIO NAME	Infant (<1 yr)	Young Toddler (1-<2 yrs)	Toddler (2-<3 yrs)	Small Child (3-<6 yrs)	Child (6-<11 yrs)	Teen (11-<16 yrs)	Adult (16-<70 yrs)
8. Installation of XPS/EPS Foam Insulation in Residential, Public, and Commercial Buildings, and Other Structures	4.0E-05 - 1.4E-04	3.0E-05 - 1.3E-04	1.9E-05 - 1.1E-04	1.4E-05 - 7.9E-05	8.7E-06 - 5.5E-05	4.5E-06 - 3.9E-05	3.2E-06 - 2.7E-05
9. Demolition and Disposal of XPS/EPS Foam Insulation in Residential, Public and Commercial Buildings, and Other Structures	4.0E-05 - 8.7E-04	3.0E-05 - 8.3E-04	1.8E-05 - 7.2E-04	1.4E-05 - 5.4E-04	8.6E-06 - 3.8E-04	4.4E-06 - 2.8E-04	3.1E-06 - 1.9E-04
10. Recycling of EPS Foam	3.9E-05 - 2.4E-04	2.9E-05 - 2.2E-04	1.8E-05 - 1.8E-04	1.3E-05 - 1.4E-04	8.2E-06 - 9.6E-05	4.1E-06 - 6.8E-05	2.9E-06 - 4.7E-05
11. Formulation of Solder	4.0E-05 - 2.3E-04	2.9E-05 - 2.1E-04	1.8E-05 - 1.8E-04	1.3E-05 - 1.3E-04	8.4E-06 - 9.3E-05	4.2E-06 - 6.7E-05	3.0E-06 - 4.6E-05
12. Use of Solder	3.9E-05 - 4.1E-05	2.9E-05 - 3.0E-05	1.8E-05 - 1.9E-05	1.3E-05 - 1.4E-05	8.2E-06 - 8.9E-06	4.1E-06 - 4.6E-06	2.9E-06 - 3.2E-06

Table 2-104. Range of HBCD Aggregate Exposure Average Daily Dose (mg/kg/day): Background and Modeled Inhalation Dose by Scenario and Age

SCENARIO NAME	Infant (<1 yr)	Young Toddler (1-<2 yrs)	Toddler (2-<3 yrs)	Small Child (3-<6 yrs)	Child (6-<11 yrs)	Teen (11-<16 yrs)	Adult (16-<70 yrs) - CT	Adult (16-<70 yrs) - HE
1. Import/Repackaging	4.0E-05 - 4.2E-05	2.9E-05 - 3.2E-05	1.8E-05 - 2.1E-05	1.3E-05 - 1.5E-05	8.3E-06 - 9.9E-06	4.2E-06 - 5.3E-06	2.9E-06 - 3.1E-06	3.0E-06 - 3.4E-06
2. Compounding of Polystyrene Resin to Produce XPS Masterbatch	3.9E-05 - 3.9E-05	2.9E-05 - 2.9E-05	1.8E-05 - 1.8E-05	1.3E-05 - 1.3E-05	8.2E-06 - 8.2E-06	4.1E-06 - 4.1E-06	2.9E-06 - 2.9E-06	2.9E-06 - 2.9E-06
3. Manufacturing of XPS Foam using XPS Masterbatch	3.9E-05 - 3.9E-05	2.9E-05 - 2.9E-05	1.8E-05 - 1.8E-05	1.3E-05 - 1.3E-05	8.2E-06 - 8.2E-06	4.1E-06 - 4.1E-06	2.9E-06 - 2.9E-06	2.9E-06 - 2.9E-06
4. Manufacturing of XPS Foam using HBCD Powder	3.9E-05 - 3.9E-05	2.9E-05 - 2.9E-05	1.8E-05 - 1.8E-05	1.3E-05 - 1.3E-05	8.2E-06 - 8.3E-06	4.1E-06 - 4.2E-06	2.9E-06 - 2.9E-06	2.9E-06 - 3.0E-06
5. Manufacturing of EPS Foam from Imported EPS Resin Beads	4.0E-05 - 4.6E-05	2.9E-05 - 3.6E-05	1.8E-05 - 2.4E-05	1.3E-05 - 1.9E-05	8.5E-06 - 1.2E-05	4.3E-06 - 6.8E-06	2.9E-06 - 3.4E-06	3.0E-06 - 4.1E-06
6. Manufacturing of SIPs and Automobile Replacement Parts	3.9E-05 - 4.4E-05	2.9E-05 - 3.3E-05	1.8E-05 - 2.2E-05	1.3E-05 - 1.7E-05	8.2E-06 - 1.1E-05	4.1E-06 - 5.8E-06	2.9E-06 - 3.2E-06	2.9E-06 - 3.7E-06
7. Installation of Automobile Replacement Parts	No air releases							
8. Installation of XPS/EPS Foam Insulation in Residential, Public, and Commercial Buildings, and Other Structures	3.9E-05 - 3.9E-05	2.9E-05 - 2.9E-05	1.8E-05 - 1.8E-05	1.3E-05 - 1.3E-05	8.2E-06 - 8.3E-06	4.1E-06 - 4.2E-06	2.9E-06 - 2.9E-06	2.9E-06 - 2.9E-06
9. Demolition and Disposal of XPS/EPS Foam Insulation in Residential, Public and	3.9E-05 - 3.9E-05	2.9E-05 - 2.9E-05	1.8E-05 - 1.8E-05	1.3E-05 - 1.3E-05	8.2E-06 - 8.2E-06	4.1E-06 - 4.1E-06	2.9E-06 - 2.9E-06	2.9E-06 - 2.9E-06

SCENARIO NAME	Infant (<1 yr)	Young Toddler (1-<2 yrs)	Toddler (2-<3 yrs)	Small Child (3-<6 yrs)	Child (6-<11 yrs)	Teen (11-<16 yrs)	Adult (16-<70 yrs) - CT	Adult (16-<70 yrs) - HE
Commercial Buildings, and Other Structures								
10. Recycling of EPS Foam	3.9E-05 - 3.9E-05	2.9E-05 - 2.9E-05	1.8E-05 - 1.8E-05	1.3E-05 - 1.3E-05	8.2E-06 - 8.2E-06	4.1E-06 4.1E-06	2.9E-06 - 2.9E-06	2.9E-06 - 2.9E-06
11. Formulation of Solder	3.9E-05 - 3.9E-05	2.9E-05 - 2.9E-05	1.8E-05 - 1.8E-05	1.3E-05 - 1.3E-05	8.2E-06 - 8.2E-06	4.1E-06 4.1E-06	2.9E-06 - 2.9E-06	2.9E-06 - 2.9E-06
12. Use of Solder	3.9E-05 - 3.9E-05	2.9E-05 - 2.9E-05	1.8E-05 - 1.8E-05	1.3E-05 - 1.3E-05	8.2E-06 - 8.2E-06	4.1E-06 4.1E-06	2.9E-06 - 2.9E-06	2.9E-06 - 2.9E-06

2.4.4 Consumer Exposures

2.4.4.1 Approach and Methodology

In this evaluation, consumers include individuals who have articles containing HBCD in their homes or automobiles. Quantitative exposure estimates were developed for the consumer exposure scenarios as described in Figure 2-9 based on the conditions of use within the scope of this Risk Evaluation.

Uses	Summary of Release Types	Summary of Media or Pathways	Exposure Scenarios	Media Estimation Methods
EPS/XPS Insulation in Residences (C1)	Mass transfer from foam (residence) or replacement parts (automobile) to particles	Indoor Air; Settled and Suspended Dust	Defined by: <ul style="list-style-type: none"> • Consumer use • Time spent in location • Emission rate • Sorption rate • Air flow rate 	<u>Air</u> <ul style="list-style-type: none"> • Modeled: IECCU <u>Dust</u> <ul style="list-style-type: none"> • Modeled: IECCU <u>Other</u> <ul style="list-style-type: none"> • Background (CT)
HBCD Contained in Automobile Components (C2)				
Recycled Consumer Articles (C3)	Extraction by saliva	Mouthing	Defined by: <ul style="list-style-type: none"> • Concentration in article • Saliva extraction efficiency 	<u>Mouthing</u> <ul style="list-style-type: none"> • Ingested Dose <u>Other</u> <ul style="list-style-type: none"> • Background (CT)

Figure 2-9. Overview of Exposure Assessment Method for Consumer Exposure Scenarios

Scenario C1 (emissions from XPS/EPS insulation installed in residential homes) corresponds to condition of use #8 and #9 and Scenario C2 (emissions from HBCD-containing automobile components) corresponds to condition of use #7. For these scenarios the presence and fate of HBCD in vapor phase, settled dust, airborne particulate matter, and interior surfaces was investigated through a series of simulations conducted for a “typical” residential building and a “typical” passenger vehicle by using existing mass transfer models and simulation tools. Most parameters were either obtained from data in the literature or estimated with empirical and QSAR models. All the simulations were conducted with IECCU version 1.1 ([U.S. EPA 2019p](#)). The modeling results were compared with limited experimental data. The predicted HBCD concentrations in settled dust in the living space were in line with the field measurements. Additionally, the predicted temperature dependence of the HBCD emission rate is in good agreement with the laboratory testing results reported by the Japanese researchers. Additional details are provided in 5.4.2 Appendix G. Doses over time were estimated using modeled concentrations for the time spent in the simulated microenvironment and measured concentrations for time spent in other environments (*i.e.*, general population estimates).

2.4.4.2 XPS/EPS Insulation In Residences — Indoor Air and Settled Dust

Equation 2-23 and Equation 2-24 were used to estimate inhalation and dust ingestion, respectively, from XPS/EPS insulation in residence. Total dose was calculated as a sum of the inhalation and incidental ingestion routes.

Equation 2-23

$$ADR \text{ and } ADD = \frac{AC_{total} \times IR \times CF \times ED}{BW \times AT}$$

ADR and ADD = Acute dose rate (ADR) or average daily dose (ADD) or due to inhalation of vapor and airborne particulate matter (mg/kg-day)

AC_{total} = Concentration in indoor air across all microenvironments accounting for time spent in each microenvironment ($\mu\text{g}/\text{m}^3$)

IR = Inhalation Rate (m^3/day)

CF = Conversion factor for mg/ μg (0.001)

ED = Exposure duration (1 day for ADR or years in age group for ADD)

BW = Body weight (kg)

AT = Averaging time, non-cancer (1 day for ADR or years in age group for ADD)

Where:

$$AC_{total} = (AC_{modeled} \times FD_{modeled}) + (AC_{other} \times (1 - FD_{other}))$$

AC_{total} = Concentration in indoor air across all microenvironments accounting for time spent in each microenvironment ($\mu\text{g}/\text{m}^3$)

AC_{modeled} = Concentration in modeled indoor air of simulated microenvironment ($\mu\text{g}/\text{m}^3$)

AC_{other} = Concentration in air (ambient and indoor) of other microenvironments ($\mu\text{g}/\text{m}^3$)

FD = Fraction of time spent in simulated residence over 24 hrs (unitless)

Equation 2-24

$$ADR \text{ and } ADD = \frac{DC_{total} \times IR \times CF \times ED}{BW \times AT}$$

ADR and ADD = Acute dose rate (ADR) or average daily dose (ADD) to inhalation of vapor and airborne particulate matter (mg/kg-day)

DC = Concentration in indoor dust across all microenvironments accounting for time spent in each microenvironment ($\mu\text{g}/\text{g}$)

IR = Dust Ingestion Rate (g/day)

CF = Conversion factor for mg/ μg (0.001)

ED = Exposure duration (1 day for ADR or years in age group for ADD)

BW = Body weight (kg)

AT = Averaging time, non-cancer (1 day for ADR or years in age group for ADD)

Where:

$$DC_{total} = (DC_{modeled} \times FD_{modeled}) + (DC_{other} \times (1 - FD_{other}))$$

DC_{total} = Concentration in indoor dust across all microenvironments accounting for time spent in each microenvironment ($\mu\text{g}/\text{g}$)

DC_{modeled} = Concentration in modeled indoor dust of simulated microenvironment ($\mu\text{g}/\text{m}^3$)

DC_{other} = Concentration in indoor dust of other microenvironments ($\mu\text{g}/\text{m}^3$)

FD = Fraction of time spent in simulated residence while awake (unitless)

IECCU was used to model indoor air and dust concentrations in the living area of a three-zone generic residential building, as described by Bevington et al. ([Bevington et al. 2017](#)). The HBCD source was unfaced polystyrene insulation boards containing 0.5% HBCD, applied to both a vented attic and vented crawlspace. Model inputs are described in further detail in Appendix G. The concentration of air and dust in other microenvironments was assumed to be equivalent to the general population air and dust estimates.

Age-specific ADR values used the highest modeled 24-hour average indoor air and dust concentration in the simulated residence and the high-end general population estimates in the other microenvironment, combined with a high-end intake. For age-specific ADD values, the long-term average indoor air and dust concentration in the simulated residence and the central tendency general population estimates in the other microenvironment were combined with central tendency intake. The concentrations were weighted for the time spent in the simulated microenvironment (residence) and other microenvironments (outdoors, vehicle, and/or commercial/public/government/child occupied facilities) over 24 hours (for inhalation exposure) or while awake (for incidental ingestion exposure). The fractions of time spent were derived from an analysis of CHAD activity pattern data for stay-at-home, part-time, and/or full-time populations ([U.S. EPA 2009b](#)). The maximum fraction of time spent in the simulated environment was used for the ADR (0.83 for air and 0.85 for dust) and the central fraction of time spent in the simulated environment was used for the ADD (0.71 for air and 0.62 for dust). Age-specific inhalation rates (mean and 95th percentiles), dust ingestion rates (mean and 95th percentiles), and bodyweights (mean) for males and females were calculated from Exposure Factors Handbook ([U.S. EPA 2011b](#)) and are provided in Appendix G.

The total dose estimates for Scenario C1 are provided in Table 2-105, Table 2-106 for the ADD and Table 2-107 for ADR. These tables also provide aggregate doses considering the addition of background exposures from the diet, soil, and dermal pathways calculated for the general population.

Table 2-105. Age Specific ADR Associated with Residential Insulation Scenario C1

Age Group	TOTAL (Dust + Air) ADR (mg/kg/day)	AGGREGATE ADR (mg/kg/day)
Infant (<1 year)	2.3E-04	2.6E-04
Young Toddler (1-<2 years)	2.1E-04	2.9E-04
Toddler (2-<3 years)	1.8E-04	1.8E-04
Small Child (3-<6 years)	1.3E-04	1.4E-04
Child (6-<11 years)	8.3E-05	8.7E-05
Teen (11-<16 years)	4.5E-05	4.7E-05
Adult (16-<78 years)	3.0E-05	3.2E-05

Table 2-106. Age Specific ADD Associated with Residential Insulation Scenario C1

Age Group	TOTAL (Dust + Air) ADD (mg/kg/day)	AGGREGATE ADD (mg/kg/day)
Infant (<1 year)	5.0E-05	7.4E-05
Young Toddler (1-<2 years)	5.5E-05	6.6E-05
Toddler (2-<3 years)	3.5E-05	4.4E-05

Age Group	TOTAL (Dust + Air) ADD (mg/kg/day)	AGGREGATE ADD (mg/kg/day)
Small Child (3-<6 years)	2.7E-05	3.4E-05
Child (6-<11 years)	1.8E-05	2.2E-05
Teen (11-<16 years)	1.0E-05	1.3E-05
Adult (16-<78 years)	7.0E-06	9.0E-06

Total doses are of a similar order of magnitude to those estimates for general population. Both the ADR and ADD estimates are generally slightly higher than the respective general estimates. All modeled doses (air + dust) are within a factor of eight when compared to general population estimates. Aggregate doses are up to eight times higher than the general population estimates when incorporating the Scenario C1 dust and air estimates.

2.4.4.3 Automobile Components that Contain HBCD — Indoor Air and Settled Dust

Exposures from automobile components that contain HBCD (Scenario C2) were assessed using a similar modeling approach as for Scenario C1. Equation 2-23 and Equation 2-24 were used to calculate the air and dust doses, and were then combined to provide a total dose.

IECCU was used to model indoor air and dust concentrations in the interior of a small SUV, assuming a moving vehicle with windows closed for the air concentration and a stationary vehicle for the dust concentration. The HBCD content in the polymer was assumed to be 2.5%. Model inputs are described in further detail in Appendix G. The concentration of air and dust in other microenvironments was assumed to be equivalent to the general population air and dust estimates.

As with Scenario C1, age-specific ADR values used the highest modeled 24-hour average indoor air and dust concentration in the simulated environment (vehicle) and the high-end general population estimates in the other microenvironment, combined with a high-end intake. For age-specific ADD values, the long-term average indoor air and dust concentration in the simulated vehicle and the central tendency general population estimates in the other microenvironment were combined with central tendency intake. The concentrations were weighted for the time spent in the simulated microenvironment (vehicle) and other indoor microenvironments (outdoors, residence and/or commercial/public/government/child occupied facilities) over 24 hours (for inhalation exposure) or while awake (for incidental ingestion exposure). The fractions of time spent were derived from an analysis of CHAD activity pattern data for stay-at-home, part-time, and/or full-time populations ([U.S. EPA 2009b](#)). In the simulated environment, the time spent was 0.083 for air and 0.15 for dust (representing both the maximum and median time spent of the three populations). Age-specific inhalation rates (mean and 95th percentiles), dust ingestion rates (mean and 95th percentiles), and bodyweights (mean) for males and females were calculated from Exposure Factors Handbook ([U.S. EPA 2011b](#)) and are provided in Appendix G.

The total dose estimates for Scenario C2 are provided in Table 2-107 for ADR and Table 2-108 for the ADD. These tables also provide aggregate doses considering the addition of background exposures from the diet, soil, and dermal pathways calculated for the general population.

Table 2-107. Age Specific ADR Associated with HBCD in Automobile Component Scenario C2

Age Group	TOTAL (Dust + Air) ADR (mg/kg/day)	AGGREGATE ADR (mg/kg/day)
Infant (<1 year)	7.8E-04	8.0E-04
Young Toddler (1-<2 years)	6.8E-04	6.9E-04
Toddler (2-<3 years)	5.6E-04	5.7E-04
Small Child (3-<6 years)	4.2E-04	4.2E-04
Child (6-<11 years)	2.5E-04	2.5E-04
Teen (11-<16 years)	1.1E-04	1.1E-04
Adult (16-<78 years)	6.8E-05	7.0E-05

Table 2-108. Age Specific ADD Associated with HBCD in Automobile Component Scenario C2

Age Group	TOTAL (Dust + Air) ADD (mg/kg/day)	AGGREGATE ADD (mg/kg/day)
Infant (<1 year)	1.8E-04	2.1E-04
Young Toddler (1-<2 years)	2.1E-04	2.2E-04
Toddler (2-<3 years)	1.1E-04	1.2E-04
Small Child (3-<6 years)	8.0E-05	8.7E-05
Child (6-<11 years)	4.8E-05	5.2E-05
Teen (11-<16 years)	2.1E-05	2.4E-05
Adult (16-<78 years)	1.4E-05	1.6E-05

2.4.4.4 Recycled Consumer Articles that Contain HBCD — Mouthing

EPA identified information in the open literature that describes articles which contain HBCD, and recognizes this as an important exposure pathway for young children who may mouth articles (Scenario C3). EPA considered mouthing of recycled plastic products using experimental product-testing information on HBCD content in consumer articles. EPA identified four data sources that measured HBCD content and provided additional contextual information on the type of consumer article and whether it was new or recycled ([Abdallah et al. 2018](#); [Vojta et al. 2017](#)). EPA determined which of these consumer articles were not likely to be mouthed (*i.e.*, insulation products, building materials, laboratory materials) and which products could be mouthed (*i.e.*, food packaging materials, toys, carpets, upholstery) based on professional judgment. This scenario does not apply for children who exude soil pica. Equation 2-25 was used to estimate average daily dose (ADD) and acute dose rate (ADR) for a 0-1 year old and a 1-2 year old from mouthing of articles.

Equation 2-25

$$ADD \text{ and } ADR = \frac{MR \times SA \times T \times CF \times ED \times EF}{BW \times AT}$$

ADD and ADR = Average daily dose (ADD) or acute dose rate (ADR) from mouthing of articles (mg/kg-day)

MR = Migration rate into saliva ($\mu\text{g}/\text{cm}^2/\text{hr}$)

SA = Surface area of object in contact with the mouth (cm^2)
 T = Daily mouthing time (hr/day)
 CF = Conversion factor for $\text{mg}/\mu\text{g}$ (0.001)
 ED = Exposure duration (1 day for ADR and 1 year for ADD)
 EF = Exposure frequency (1 day/year for ADR and 365 days/year for ADD)
 BW = Body weight (kg)
 AT = Averaging time (1 day for ADR and 1 year for ADD)

Where:

$$T = MD \times CF \times TA$$

T = Daily mouthing time (hr/day)
 MD = Hourly mouthing duration (min/hr)
 CF = Conversion factor for hr/min (0.0167)
 TA = Time awake (hr/day)

EPA did not identify experimental data that measured migration of HBCD into saliva. Therefore, a regression between concentration and migration rate into saliva for a variety of other chemicals found in consumer products ([U.S. EPA 2019r](#)) was used to estimate the HBCD migration rate (MR; $y=2E-05x^{0.9851}$). For surface area of objects in contact with the mouth (SA), the central tendency value (10 cm^2) was used to calculate ADD while the high-end value (50 cm^2) was used to calculate ADR ([OECD 2019](#)). Hourly mouthing durations are based time spent mouthing all non-pacifier items. The mean and 95th percentiles, used for the ADD and ADR respectively, are 7.1 and 13.1 min/hr for infants (0-<1 year olds) and 4.7 and 12.8 min/hr for 1 to 2 year olds (Table 4-20 of ([U.S. EPA 2011b](#))). The time awake (TA) of 13 hours was derived from the Consolidated Human Activity Patterns Database (CHAD) ([U.S. EPA 2009b](#)) and mean bodyweights were derived from the Exposure Factors Handbook ([U.S. EPA 2011b](#)). All default values used to estimate ADD and ADR from mouthing of articles containing HBCD are provided in Appendix G.1.

The total dose estimates for Scenario C3 are provided in Table 2-109 for the ADD and ADR.

Table 2-109. Estimated Exposure from Mouthing of Articles Containing HBCD

Summary Statistic	HBCD Concentration in Consumer Articles Likely to be Mouthed (ppm)	Migration Rate into Saliva ($\mu\text{g}/\text{cm}^2/\text{hr}$)	Infants (0-1 Year Old)		Young Toddlers (1-2 Year Old)	
			ADR ($\text{mg}/\text{kg}/\text{day}$)	ADD ($\text{mg}/\text{kg}/\text{day}$)	ADR ($\text{mg}/\text{kg}/\text{day}$)	ADD ($\text{mg}/\text{kg}/\text{day}$)
min	0.00015	4.0E-09	7.3E-11	7.9E-12	4.9E-11	3.6E-12
10th	0.00015	4.0E-09	7.3E-11	7.9E-12	4.9E-11	3.6E-12
50th	0.00110	2.9E-08	5.2E-10	5.6E-11	3.5E-10	2.6E-11
geomean	0.00693	1.8E-07	3.2E-09	3.5E-10	2.2E-09	1.6E-10
75th	0.12826	3.1E-06	5.6E-08	6.1E-09	3.8E-08	2.8E-09
90th	7.48151	1.7E-04	3.1E-06	3.4E-07	2.1E-06	1.5E-07
95th	48.38230	1.1E-03	2.0E-05	2.1E-06	1.3E-05	9.7E-07
97th	243.34410	5.3E-03	9.6E-05	1.1E-05	6.5E-05	4.8E-06
98th	1,147	2.4E-02	4.4E-04	4.8E-05	3.0E-04	2.2E-05
99th	23,792	4.8E-01	8.7E-03	9.5E-04	5.9E-03	4.3E-04
max	51,180	1.0E+00	1.9E-02	2.0E-03	1.3E-02	9.2E-04

The concentration of HBCD present in 97% of the consumer articles identified as likely to be mouthed ranged from <1 ppm to 250 ppm. While HBCD can be present in many consumer articles, presence at levels <250 ppm is not likely to impart flame retardancy and is likely due to mixing of recycled feedstocks from many sources. Generally, as the concentration of HBCD increases, the potential for imparting flame retardancy and the potential for exposure increases. Presence of HBCD at higher levels (>250 ppm) may also be due to mixing of recycled feedstocks from many sources. For this analysis, EPA used all data for products likely to be mouthed rather than identify a lower or upper cut-off based on the potential for exposure and/or the potential for imparting flame retardancy. Based on these data, the highest estimated ADR exposure was 1.86E-02 mg/kg/day for infants and 1.26E-02 mg/kg/day for 1 to 2 year olds. The highest estimated ADD exposure was 2.01E-03 for infants and 9.24E-04 for 1 to 2 year olds.

When the maximum mouthing specific ADD and ADR estimates are combined with the general population background ADDs, the aggregate ADD and ADR, respectively, are 2.05E-03 and 1.86E-02 mg/kg/day for infants (0-<1 year olds) (98.6% to 99.8% of the total dose) and 9.53E-04 and 1.26E-02 mg/kg/day for 1 to 2 years olds (96.9 to 99.8% of the total dose).

2.4.5 Qualitative Exposure Scenarios

This section describes qualitative or semi-quantitative scenarios used to provide context for exposure scenarios that were identified in EPA's conceptual model but that were not ultimately quantified and carried through for risk characterization. While some of these scenarios do provide quantitative estimates, these values are provided with the sole purpose to provide context for EPA's best estimate of potential exposure. These estimates are highly uncertain and are based on limited data. While these scenarios have exposure potential, exposures are likely to be highly variable for reasons described below.

2.4.5.1 Emissions to Ambient Air from EPS and XPS Insulation in Residences

Ventilation is the most important means by which HBCD is removed from the indoor environment. The HBCD release rate from a typical home with XPS/EPS insulation was determined from the IECUU modeling conducted for consumer scenario C1. As shown in the mass balance results table in Appendix G the total HBCD vented out over a 100-day period is 2.06×10^6 μg ; therefore, the source exposure for a single home is 2.06×10^4 $\mu\text{g}/\text{day}$ (2.06×10^6 $\mu\text{g} \div 100$ days).

To estimate the effect of indoor emissions on ambient air, consider a 100-square mile, densely populated urban area with a housing density of 1,000 units per square mile. In this example, the total source strength is 2.06×10^9 $\mu\text{g}/\text{day}$.

$$\text{Total source strength} = 2.06 \times 10^4 \mu\text{g}/\text{day} \times 100 \text{ mile}^2 \times 1,000 \text{ units}/\text{mile}^2 = 2.06 \times 10^9 \mu\text{g}/\text{day}$$

Next, the size of the air box that moves through the urban area over a 24-h period was calculated using the mixing height, wind speed and travel distance, and diameter of the city area. The mixing height in urban area is usually between 300 and 1,000 m. Consider the worse-case scenario with a mixing height of only 150 m due to temperature inversion, which was the case during the London fog episode in 1952. The worst-case scenario also occurs when there is little wind. In this calculation, a wind speed of 1 m/s was used (*i.e.*, the Beaufort number = 1 on a 0-to-12 scale). Thus, the distance of the air will travel over a 24-h period is $1 \text{ m/s} \times 3,600 \text{ s/h} \times 24 \text{ h} = 86,400 \text{ m}$. Furthermore, the diameter of the city area (100 mile^2) is 18,200 m. From these values, the size of the air box moving through the city over a 24-h period can be calculated:

$$\text{Air box volume} = 150 \text{ m} \times 86,400 \text{ m} \times 18,200 \text{ m} = 2.35 \times 10^{11} \text{ m}^3$$

Dividing the total source strength by the air volume yields the HBCD concentration in the urban air below the mixing height:

$$\text{Possible Concentration} = 2.06 \times 10^9 \text{ } \mu\text{g} \div 2.35 \times 10^{11} \text{ m}^3 = 8.75 \times 10^{-3} \text{ } \mu\text{g}/\text{m}^3$$

If other factors are considered such as other types of buildings which may have insulation and the fraction of total buildings that have HBCD EPS or XPS insulation as opposed to other kinds of insulation, there is additional variability that should be considered in the quantified air concentration. It is noteworthy that this estimated air concentration is near the top-end of the range for extracted ambient air monitoring data. In summary, emissions from HBCD insulation to ambient air represent a potential ongoing source of exposure to the environment.

2.4.5.2 HBCD Sent to Landfill Across the Lifecycle

HBCD is not designated as a RCRA hazardous waste because it is not specifically listed as a known hazardous waste and does not exhibit the characteristics of a hazardous waste (ignitability, corrosivity, reactivity or toxicity) described under RCRA (40 CFR § 261). Because HBCD is not a RCRA hazardous waste, HBCD wastes from across its lifecycle can be disposed of in hazardous waste, municipal, or Construction and Demolition (C&D) landfills. Municipal and hazardous waste landfill design and management controls such as coverings, liners, and leachate collection and treatment may partially or fully mitigate migration of HBCD through landfills to groundwater. However, these features may be less common for Construction and Demolition landfills which may be subject to less strict design requirements and regulation.

The potential for landfilled HBCD to migrate through these landfills and reach receptors was qualitatively assessed. There is a low potential for HBCD released to landfills to migrate through the landfill to groundwater and reach receptors via groundwater ingestion or groundwater entering surface water. HBCD is a solid and likely to be entrained in a solid matrix (XPS/EPS foam) when disposed of in a landfill. HBCD's high soil organic carbon partition coefficient (>100,000) and low water solubility (66 ug/L) indicates it will preferentially partition to soil organic carbon and exhibit very slow movement through soil to groundwater.

Very few studies to inform the potential for HBCD to migrate from landfills to the environment were found. Available studies address the potential for HBCD to leach from substrates such as waste plastics and XPS/EPS under laboratory conditions, and analysis of field collected landfill leachate for HBCD.

HBCD leaching through mixed waste and organic matter in lysimeters intended to represent conditions in a municipal landfill were conducted by ([Kajiwara et al. 2014](#)). The waste contained approximately 13% by weight waste plastic. The plastic waste added to the lysimeter was determined to contain 390 ng/g total HBCD and the composite waste 4100 ng/g. The lysimeters were subjected to simulated rainfall, and HBCD was detected in leachate from the beginning of the experiment before declining to below the detection limit within 4 months. The study, which used waste materials as found (*i.e.*, not treated with additional HBCD), resulted in peak concentrations of 75 ng/L in leachate. ([Stubbings and Harrad 2019](#)) examined the leachability of HBCD from treated EPS and XPS foams. Concentrations in pure water leachate from both foam types were in the high- $\mu\text{g}/\text{L}$ range, and in the low- mg/L range when dissolved humic matter was included in the leaching fluid as an extractant. The concentrations measured in this study were likely dominated by a fraction associated with small (<0.45 μm) foam particles

generated by abrasion. Preferential partitioning to these foam particle solids would be consistent with the physicochemical properties of HBCD (low water solubility, high log K_{ow}).

The results of these studies address the partitioning of HBCD from simulated landfill waste material or XPS/EPS foam to leachate, but do not address mitigation of HBCD movement by landfill leachate controls if present, or dilution/attenuation in soil. The relationship between HBCD loading in the study and HBCD loading of U.S. landfills is unknown. Thus, applying these results to leaching of HBCD in U.S. landfills to the environment would introduce significant uncertainty.

A limited number of HBCD landfill leachate monitoring studies were found. A study of leachates collected from three landfills in South Africa found detectable concentrations of HBCD isomers in the particulate phase but not in the dissolved phase (defined as passing through 0.45 µm filter paper) ([Daso et al. 2017](#); [Olukunle and Okonkwo 2015](#); [Gavilan-Garcia et al. 2017](#); [Remberger et al. 2004](#)).

The available leachate monitoring data are limited to non-U.S. sites. The loading of HBCD to U.S. landfills is unknown, as is whether the loadings result from current COUs or when they occurred. Leaching from landfills may provide a pathway for exposure, but the resulting concentrations in groundwater and surface water will be greatly attenuated by partitioning from water to solids and retardation of particle transport.

The bioavailability of HBCD bound to solids in landfill leachate is also a source of uncertainty.

It is not currently possible to conduct a reliable quantitative assessment of HBCD exposure to human and environmental receptors via landfill leachate. Insufficient information is reasonably available to estimate HBCD landfill loadings on a per landfill basis that would be required to estimate leachate concentrations. Generic characterization of the geology and hydrology associated with landfills (underlying soil types, permeability, depth to groundwater, etc.) are lacking. Physical, chemical and biological processes which may impact HBCD transport and transformation in a landfill are not well understood.

2.4.5.3 Occupational Exposure Associated with the Condition of Use of Land Disposal of Formulated Products and Articles

The Condition of Use of Land Disposal of Formulated Products and Articles is the land disposal of articles that are a part of municipal solid waste (MSW.) The articles are specifically articles that are associated with the minor uses of HBCD, which include textiles, electronics that contain HIPS, and articles that contain adhesives and coatings.

Process Description:

Prior to disposal, solid waste may be first sent to waste transfer facilities where waste is compacted then loaded onto larger vehicles for shipment to disposal sites such as landfills (<https://www.epa.gov/sites/production/files/2016-03/documents/r02002.pdf>). At many transfer stations, workers screen incoming waste located on conveyor systems, tipping floors, or in waste pits to identify recyclables and wastes inappropriate for disposal (e.g., hazardous waste, whole tires). Workers at transfer stations operate heavy machinery such as conveyor belts, push blades, balers, and compactors, and may also clean the facility or perform equipment maintenance. Workers may be exposed to poor air quality due to dust and odor, particularly in tipping areas over waste pits (<https://www.epa.gov/sites/production/files/2016-03/documents/r02002.pdf>).

Solid waste generally arrives at landfills in trucks and is dumped into a specific location in the landfill, compacted with a compactor vehicle, and finally covered with soil from a nearby area (<https://www.cdc.gov/niosh/hhe/reports/pdfs/1993-0696-2395.pdf>). Alternatively, the solid waste that is received at a landfill is first shredded in a rotary hammer that pulverizes the waste and the shredded waste is then dumped and spread on the landfill (<https://www.cdc.gov/niosh/hhe/reports/pdfs/1991-0354-2532.pdf>.) Workers at landfills operate heavy machinery such as compactors, loaders, and bulldozers (<https://www.cdc.gov/niosh/hhe/reports/pdfs/1996-0109-2616.pdf>). This heavy machinery is used to handle solid waste as well as soil used for daily cover (<https://www.cdc.gov/niosh/hhe/reports/pdfs/1996-0109-2616.pdf>). Heavy machinery operators may be exposed to particulates and other contaminants while in the cabs of the machinery (<https://www.cdc.gov/niosh/hhe/reports/pdfs/1996-0109-2616.pdf> and <https://www.cdc.gov/niosh/hhe/reports/pdfs/1993-0696-2395.pdf>). Mechanics servicing equipment may be exposed to residues on machinery. In addition, workers may be exposed when removing dirty work uniforms (<https://www.cdc.gov/niosh/hhe/reports/pdfs/1996-0109-2616.pdf>).

Number of Potentially Exposed Workers and Occupational Non-Users

EPA reviewed data from the BLS and related SOC codes. For workers handling waste at landfills, EPA reviewed data for NAICS code 562212, Solid Waste Landfill, which indicates there are on average an estimated 3 workers and 2 ONUs per site. For workers at waste transfer stations, EPA reviewed data for NAICS code 562219, Other Nonhazardous Waste Treatment and Disposal, which provided the same estimate for number of workers and ONUs. For 2019, the Waste Business Journal estimates 3,835 waste transfer stations and 1,786 municipal solid waste landfills ([Waste Business Journal, 2019](#)), for a total of 7,198 landfills and waste transfer stations. Some of these facilities may not receive waste products and articles containing HBCD, depending on the type of waste accepted at the facility. An upper bound estimate would be 16,863 workers and 11,242 ONUs for solid waste landfills and waste transfer stations.

Qualitative Inhalation Exposure Assessment

Occupational exposure to HBCD that results from the land disposal of MSW is comparable to occupational exposure to HBCD that is the result of the processing or handling of articles that contain HBCD because MSW disposal also involves potential worker exposure to HBCD as a result of the processing or handling of articles. The relevant occupational exposure scenarios that involve exposure that is the result of the processing or handling of articles that contain HBCD are as follows:

- (1) Installation of XPS/EPS Foam Insulation in Residential, Public and Commercial Buildings, and Other Structures;
- (2) Demolition and Disposal of XPS/EPS Foam Insulation Products in Residential, Public and Commercial Buildings, and Other Structures;

Based on the process description, the land disposal of MSW for the most part does not involve the intentional breaking of articles although some processing steps such as compaction and loading and unloading of MSW may result in the breaking of articles. The exception is the shredding of MSW. On the other hand, all the above listed scenarios involve the intentional cutting or breaking of articles. Accordingly, the rate of generation of inhalable dust resulting from the land disposal of an individual article is likely less than the rate of generation of inhalable dust resulting from the processing of an individual article in the case of any of the listed occupational exposure scenarios. Based on this, EPA assumes the HBCD worker inhalation exposure concentration resulting from the disposal of MSW apart from the shredding of MSW is lower than the HBCD worker inhalation exposure concentration pertaining to the above listed exposure scenarios. The HBCD worker inhalation exposure concentration resulting from the shredding of MSW may be greater than the HBCD worker inhalation exposure

concentration pertaining to the above listed exposure scenarios. HBCD inhalation exposure concentration is dependent on not only the dust generation rate pertaining to an individual article but also on (a) the concentration of HBCD in an article, (b) the number of articles processed per unit time, (c) engineering controls, and (d) the rate of general mechanical or natural ventilation. These factors are further discussed below in the discussion of uncertainties.

EPA assumes exposure duration and frequency are 8 hrs. per day and 250 days/year, respectively, because EPA expects that articles that contain HBCD are randomly dispersed in MSW given that these articles are used in buildings.

Discussion of Uncertainty in the Qualitative Assessment of Inhalation Exposure

1. The Concentration of HBCD in an Article:

EPA lacks data pertaining to the concentration of HBCD in textiles and in articles which contain adhesives and coatings that contain HBCD. If these concentrations were greater than the concentration of HBCD in XPS/EPS, and if dust were generated as a result of the land disposal of these article, then the concentration of HBCD in this dust will exceed the concentration of HBCD in dust that is generated as a result of cutting or breaking XPS/EPS during construction and demolition. Furthermore, if the rate of inhalable dust generation during land disposal is sufficiently high, then EPA's assumption that HBCD inhalation exposure concentration which pertains to land disposal of articles is relatively low may not be valid.

2. The Number of Articles Processed per Unit Time:

The rate of total dust generation equals the rate of total dust generation from an individual article on average multiplied by the number of articles containing HBCD that are processed per unit time at a land disposal site. EPA lacks data pertaining to the number of articles containing HBCD that are processed per unit time at a land disposal site. If this rate were sufficiently high, then EPA's assumption that the HBCD inhalation exposure concentration which pertains to land disposal of articles is relatively low may not be valid. The articles containing HBCD that are processed per unit time at a land disposal site is likely low because of the following two factors: first, the articles that contain HBCD likely comprise a small fraction of MSW and, second, for the most part HBCD was used in XPS/EPS. With regard to the first factor, in 2017, 6.3% of the municipal solid waste was from textiles, and less than 2% was from electronics (with 36% of this recycled), (https://www.epa.gov/facts-and-figures-about-materials-waste-and-recycling/guide-facts-and-figures-report-about-materials#Materials_and_Products and (U.S. EPA 2019o). Even if acute HBCD inhalation exposure concentration is relatively high because EPA's relevant assumptions pertaining to inhalation exposure concentration are not valid, the average HBCD inhalation exposure concentration may nonetheless be relatively low if the number of articles were low.

3. Engineering Controls and General Mechanical or Natural Ventilation:

The land disposal of MSW is an open process (*i.e.*, material is not processed in enclosed equipment) although the shredding of MSW may be a partially enclosed process. Similarly, all the occupational exposure scenarios listed above involve open processes. All the occupational exposure scenarios discussed above including the Land Disposal of Formulated Products and Articles involve outdoor and indoor workplaces and therefore all ventilation rates may be comparable although EPA is uncertain of this.

4. HBCD Inhalation Exposure Concentration Associated with Shredding of MSW:

EPA lacks information about the prevalence of the shredding of MSW; if this step were not prevalent, then the number of workers who would be potentially exposed would be low. The average HBCD inhalation concentration may be low if the number of articles containing HBCD that are shredded per unit time is low and/or if there are engineering controls to protect against worker exposure. However, there may be acute worker exposure.

Qualitative Dermal Exposure Assessment

During the land disposal of MSW, workers may handle the articles that contain HBCD, but EPA does not expect worker dermal exposure because the HBCD is entrained in the articles. Workers may be exposed to settled dust that contains HBCD as a result of the shredding of MSW.

2.4.6 Sensitivity Analysis - Human Exposure

2.4.6.1 Sensitivity Analysis – Infant Exposures

For the highly exposed general population, EPA further considered infant exposures and reports additional percentiles beyond the 95th percentile using different assumptions. In EPA's approach, the selection of which upper percentile is assigned to the high-end monitoring data is generally more sensitive than the selection of the geometric mean.

In this sensitivity analysis, EPA examined the effect of varying three assumptions related to the stochastic modeling of HBCD aggregate dose for infants (<1 year) in the general population:

1. In the baseline stochastic analysis of HBCD doses modeled above, only the 95th percentile estimate of modeled HBCD doses is reported as a high-end estimate. In this analysis, EPA also reported the 96th, 97th, 98th, 99th, and 99.5th percentiles of estimated HBCD dose.
2. In the baseline (previous) analysis, environmental concentrations were assumed to follow lognormal distributions, with the central tendency and high-end concentrations reported in monitoring data used to define the shape of the lognormal distribution. Specifically, the central tendency estimate from monitoring data was assumed to correspond to the median of the lognormal distribution, while the high-end estimate from monitoring data was assumed to correspond to either the 95th percentile (for soil and dust) or the 90th percentile (all other environmental and biotic media). In this analysis, EPA varied this assumption by allowing all high-end monitoring data values to represent the 90th, 95th, and 99th percentile of the underlying lognormal distribution.
3. In the baseline analysis, the central tendency estimate from monitoring data was assumed to correspond to the median of the lognormal distribution, which is equivalent to assuming that the central tendency estimate was equal to the geometric mean of the underlying distribution. In this analysis, EPA varied this assumption by 10% in either direction of the geometric mean to evaluate the sensitivity of the output to the central tendency estimate.

The results of varying assumptions 1 and 2 in the sensitivity analysis are visualized in Figure 2-10. The x-axis shows alternative percentiles that can be used to estimate the high-end dose, ranging from the 95th to the 99.5th percentile of the output dose distribution. The y-axis displays the estimated dose in mg/kg/day at each of these percentiles. The different curves each represent an alternative assumption with respect to the shape of the underlying environmental distributions. Specifically, each series presents an analysis based on assuming the reported high-end monitoring data value for environmental concentrations represented either the 90th, 95th, or 99th percentile of the underlying lognormal distribution; the baseline analysis is also pictured. Results for the 99%, and 99.5% percentile, and

maximum modeled dose for each assumption of the underlying distribution are provided in Table 2-110. Results for the 99%, and 99.5th percentile, and the maximum modeled dose for each assumption of the underlying distribution are provided in Figure 2-10.

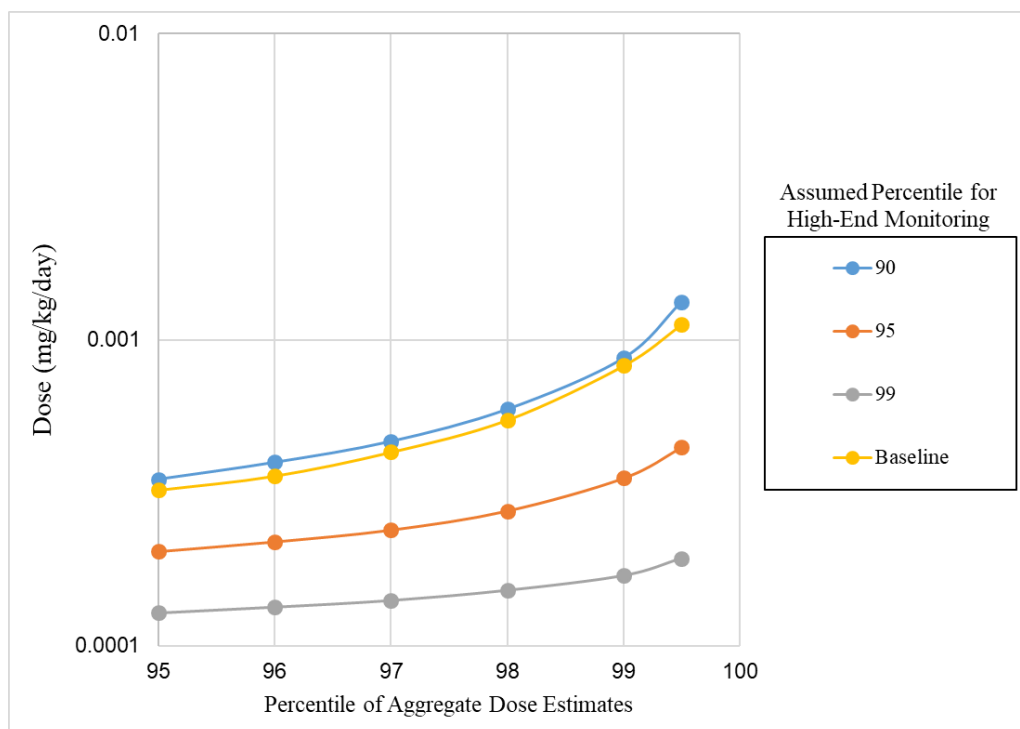

Figure 2-10. Comparison of HBCD Dose for Infants in the General Population from Different Sensitivity Analyses

Based on a Figure 2-10, it is possible to conclude:

1. High-end aggregate dose estimates are sensitive to the choice of percentile used to represent high-end doses. Choosing the 99.5th percentile of the stochastic dose output instead of the 95th percentile can increase estimated high-end dose by a factor of 3. This is consistent with the theoretical expectation that dose estimates would be left skewed in their distribution with a long tail to the right.
2. If it is assumed that the reported high-end value from monitoring data represents a higher end percentile of the underlying distribution of environmental data (*e.g.*, 99th percentile instead of 90th percentile), the estimated dose decreases. This is consistent with the theoretical expectation that a longer tail will result in larger estimated dose.
3. The baseline analysis is very similar to the analysis in which the reported high-end value from monitoring data represents the 90th percentile of the underlying distribution of environmental data. This is because the baseline analysis assumes the reported monitoring high-end estimate represents the 90th percentile for all distributions except soil and dust for which it was assumed to represent the 95th percentile.

Table 2-110. Sensitivity Analysis of Upper End Monitoring Distribution Assumptions in Monitoring Data

Assumed Percentile of Monitoring Distribution Upper End	Estimated Dose in mg/kg-day		
	99 th Percentile Estimated Dose	99.5 th Percentile Estimated Dose	Maximum Modeled Dose
90 th	8.7E-04	1.3E-03	3.6E-03
95 th	3.5E-04	4.5E-04	1.0E-03
99 th	1.7E-04	1.9E-04	3.2E-04

The results of varying assumption 3 in the sensitivity analysis are summarized in Table 2-111.

Table 2-111. Sensitivity Analysis of Central Tendency Estimate Assumptions in Monitoring Data

Estimated Dose Based on Varying Monitoring Data Central Tendency Assumption	Estimated Dose in mg/kg-day		
	Baseline GM	Baseline GM + 10%	Baseline GM - 10%
95 th Percentile Dose	3.1E-04	3.2E-04	2.9E-04
Maximum Estimated Dose	3.3E-03	3.5E-03	3.3E-04
% Change from Baseline (95 th tile)	--	4%	-7%
% Change from Baseline (Maximum Dose)	--	6%	-0%

GM = geometric mean

The highest theoretical maximum aggregate exposure to infants is 3.59E-3 mg/kg-day where the maximum modeled HBCD dose is combined with the lower (90th) assumed percentile of the underlying distribution of environmental data. This value is similar to the maximum modeled HBCD dose from the higher-end assumption (+10%) of the true central tendency value (3.45E-3 mg/kg-day).

2.4.6.2 Sensitivity Analysis – Variation in Production Volume

EPA considered releases using three production volumes acknowledging decreasing trends of releases. EPA notes that chronic doses decrease by a factor of approximately two to four when releases are similarly reduced by a factor of two to four. Acute doses are approximately the same because EPA inferred that reduced release days when the magnitude of releases decreases. EPA also considered three separate approaches to estimated fish doses and the overall magnitude and trends associated with all three approaches are similar.

A sensitivity analysis examining varying production volume and waste water treatment removal was conducted for human exposures, using a parallel approach as was described in Section 2.3.6 for environmental exposures. The results are summarized in the table below. The estimated surface water concentrations were used to derive fish ingestion doses as described previously in Section 2.4.3.2.

Table 2-112. Summary of Surface Water Concentrations from Sensitivity Analysis: Varying HBCD Production Volume and Waste Water Treatment Removal –Human Exposures (Fish Ingestion)

Scenario Name	Production Volume (lbs / year)	% WWTP Removal for Direct Releases	Surface Water 21-Day Average Dissolved Concentration Range (µg/L)	
			Acute: 10 th %-ile Flow	Chronic: 50 th %-ile Flow
Scenario 1. Import and Re-packaging/ Processing: Repackaging of Import Containers	100,000	90%	2.1E-01 - 1.4E+00	6.9E-03 - 2.0E-01
	50,000	90%	1.2E-01 - 7.5E-01	4.1E-03 - 1.0E-01
	25,000	90%	6.0E-02 - 7.1E-01	2.0E-03 - 1.0E-01
Scenario 3. Processing: Manufacturing of XPS Foam using XPS Masterbatch	100,000	0%	2.6E-03 - 9.2E-01	8.9E-05 - 3.2E-02
	50,000	0 %	1.3E-03 - 4.6E-01	4.4E-05 - 1.6E-02
	25,000	0 %	6.5E-04 - 2.3E-01	2.2E-05 - 8.2E-03
Scenario 5. Processing: Manufacturing of EPS Foam from Imported EPS Resin Beads	100,000	0 %	2.0E+00 - 3.4E+01	6.8E-02 - 1.2E+00
	50,000	0 %	4.4E-01 - 1.1E+02	1.7E-02 - 1.2E+00
	25,000	0 %	5.0E-01 - 3.6E+01	7.4E-02 - 5.0E+00

2.4.7 Assumptions and Key Sources of Uncertainty in the General Population, Highly Exposed, and Consumer Exposure Assessment

Estimates of general population exposures based on environmental monitoring and biomonitoring data represent the conditions present at the time the data was collected. It is unknown which combination of potential sources associated with conditions of use as described in this Risk Evaluation contribute to the monitoring data presented here. However, given the wide range of exposures shown within and across the monitoring data, there is a plausible contribution from some of the sources/conditions of use described within this document.

For the general population assessment, EPA used central tendency and high-end environmental monitoring data informed by all studies for a given media that passed evaluation. EPA also compared pathway specific estimates with completed assessments already reported in the literature. For example, EPA's dietary assessment is of similar magnitude or higher than those reported for other countries ([Lee et al., 2019](#); [Cao et al., 2018](#); [Barghi et al., 2016](#); [Fromme et al., 2015](#)). EPA also used all extracted biomonitoring data and estimated external doses based on assumptions of lipid-weight percentages first-order elimination, constant lipid concentrations of HBCD throughout the body, and half-life. The half-life is based on calculations using breastmilk concentrations and intakes for a group of women; however, the intake was not based on paired measurements in the subjects of the breastmilk study but instead on a general market basket study for the population as a whole. In addition, the dose reconstruction method relies on an assumption of steady state and first order elimination. Longterm exposure to HBCD from articles in the home may support an assumption of steady state, but elimination has not been adequately characterized to firmly support a first-order assumption. Finally, the assumption that all lipid throughout the body has the same concentration of HBCD cannot currently be verified using experimental data.

Because of these different assumptions, there is significant uncertainty in the dose reconstruction calculations.

While there are approximately 400 monitoring studies across all media, there are limited studies within the U.S. to characterize current and spatially diverse environmental levels. It is unknown whether the currently available HBCD concentrations in environmental media outside of the U.S. are representative of values in the U.S. While some media such as indoor dust and sediment have relatively more data, other media such as human biota and surface water are less well characterized. A qualitative assessment of the uncertainty, sensitivity, and variability associated with this approach is presented in Table 2-113 below.

Table 2-113. Qualitative Assessment of the Uncertainty and Variability Associated with General Population Assessment

Variable Name	Data Source	Uncertainty (L, H)	Variability (L, H)
General Population Exposure Assessment (based on Environmental Monitoring)			
Environmental Monitoring Data	Extracted and evaluated data (all) plus key studies	L	H
Exposure Factors and Activity Patterns	Exposure Factors Handbook	L	L
General Population Exposure Assessment (based on Biomonitoring)			
Biomonitoring Data	Extracted and evaluated data (all) plus key studies	L	H
Half-life in the body	Select studies	H	H
Lipid weight in the matrix	Select studies	L	H
One-compartment approach	(Aylward and Hays 2011)	H	H

For the highly exposed group, EPA modeled three pathways: air, water to fish (fish ingestion), and consumer articles to indoor air and dust. There are more input parameters used across these three modeling approaches. EPA balanced a combination of central tendency and high-end inputs for these modeled scenarios. Further, each scenario was split into many sub-scenarios to fully explore potential variability. Modeled estimates were compared with monitoring data to ensure overlap and evaluate the overall magnitude and trends. For example, fish ingestion doses were evaluated in three different ways (see Section 2.4.3.2). A qualitative assessment of the uncertainty and variability associated with this approach is presented in Table 2-114 below.

Table 2-114. Qualitative Assessment of the Uncertainty and Variability Associated with Highly Exposed Population Assessment

Variable Name	Descriptor (data source)	Uncertainty (L, H)	Variability (L, H)
Environmental Exposure and Highly Exposed Groups Assessment (based on Exposure modeling)			
Environmental Releases Category			
Emission Factor	Range (EU RAR, OECD ESD)	M	H
Days of Release	Range (EU RAR, EU TGD, OECD ESD)	M	H
Production Volume	CDR volume threshold /Datamyne	H	L
Directly reported Releases	Reported values (TRI)	L	L
Environmental Fate Category			
Physical-Chemical Properties: KoC, Henry's Law Constant, etc	Point estimate (measured values, modeled estimates)	L	L
BAF	Point estimate based on lower end of range (measured studies)	L	H
Half-lives of HBCD in media	Range (measured studies)	L	H
Exposure Model Parameter Category			
Water modeling defaults: river flow, dimensions, characteristics	Range, CT and HE (PSC user guide)	L	H
Air modeling defaults: meteorological data, indoor/outdoor transfer,	Range, CT and HE (IIOAC user guide)	L	H
Consumer Article modeling defaults: characterization of emissions from articles, characterization of residential and auto environments)	Range, CT and HE (IECCU user guide)	H	H
Exposure Factors and Activity Patterns	Range, CT and HE (Exposure Factors Handbook)	L	L
L = low; M = moderate; H=high			

EPA aggregated exposure across several pathways, in its general population assessment and found general agreement between different approaches. EPA also substituted modeled estimates for scenario-specific pathways for air, fish, and indoor air/dust for its assessment of highly exposed populations. There was a wide range of release estimates reported within and across scenarios which results in scenario-specific estimates that were lower than, of similar magnitude to, and higher than general population estimates. When considering pathway specific estimates and aggregate exposures, there is uncertainty associated with which pathways co-occur in a given population group. Further, there is variability within a given exposure pathway. For the same exposure scenarios, central tendency estimates are more likely to occur than high-end estimates. To address this, EPA used a stochastic approach to simulate the effect of aggregated exposures. EPA used different combinations of exposures sampling from the entire distribution for all pathways. This approach offers more clarity than static sensitivity analyses based on combining assorted high-end and/or central tendency estimates of the component distributions. For instance, combining the 95th percentile estimate of all component variables

in an exposure equation in a static sensitivity analysis may produce a conservative high-end estimate of exposure that cannot be related to a specific percentile on the exposure distribution. Instead, EPA used a stochastic analysis, and selected the 95th percentile to approximate a high-end exposure estimate. The stochastic approach, however, is subject to uncertainty stemming from assumptions relating to the component distributions. If the true component distributions differ in terms of shape and/or parameters from the assumed distributions, the estimated exposure distribution may be potentially biased, especially in the tails of the distribution.

Finally, EPA did not consider all possible exposure pathways, but rather focused on pathways that were within the scope of its conceptual model. This may result in a potential underestimation of exposure in some cases. Examples of exposure pathways that were not considered include incidental ingestion of suspended sediment and surface water during recreational swimming and ingestion of non-fish seafood such as aquatic invertebrates or marine mammals. However, EPA expects these exposures to be less than those that were included in the aggregate assessment. As such, their impact will likely be minimal and would be unlikely to influence the overall magnitude of the results.

2.4.8 Potentially Exposed or Susceptible Subpopulations

TSCA requires that a Risk Evaluation “determine whether a chemical substance presents an unreasonable risk of injury to health or the environment, without consideration of cost or other non-risk factors, including an unreasonable risk to a *potentially exposed or susceptible subpopulation* (PESS) identified as relevant to the Risk Evaluation by the Administrator, under the conditions of use.” TSCA Section 3(12) states that “the term ‘potentially exposed or susceptible subpopulation’ means a group of individuals within the general population identified by the Administrator who, due to either greater susceptibility or greater exposure, may be at greater risk than the general population of adverse health effects from exposure to a chemical substance or mixture, such as infants, children, pregnant women, workers, or the elderly.”

In developing the exposure assessment for HBCD, EPA analyzed the reasonably available information to ascertain whether some human receptor groups may have greater exposure or susceptibility than the general population to the hazard posed by HBCD. Exposures of HBCD would be expected to be higher amongst groups living near industrial facilities (*i.e.*, highly exposed general population), groups with HBCD containing products in their homes, workers who use HBCD as part of typical processes, and groups who have higher age and route specific intake rates compared to the general population.

EPA identified potentially exposed and susceptible subpopulations for further analysis during the development and refinement of the life cycle, conceptual models, exposure scenarios, and analysis plan. In Section 2.4, EPA addressed the potentially exposed or susceptible subpopulations identified as relevant based on greater exposure. EPA addresses the subpopulations identified as relevant based on greater susceptibility in Section 3.2.7.

Of the human receptors identified in the previous sections, EPA identifies the following as potentially exposed or susceptible subpopulations due to their *greater exposure* and considered them in the Risk Evaluation :

1. Workers and occupational non-users. EPA reviewed monitoring data found in published literature including both personal exposure monitoring data (direct exposure) and area monitoring data (indirect exposures) and identified data sources that contain measured monitoring data and or/estimated data for the various conditions of use (including import and processing of HBCD). Exposure estimates were developed for users (males and females workers of reproductive age) exposed to HBCD as well as non-users or workers exposed to HBCD

indirectly by being in the same work area of the building (Table 2-80 and Table 2-81). Workers exhibit higher breathing rates than the general population at rest, leading to elevated internal dose even when exposed to similar air concentrations. Also, adolescents and female workers of reproductive age (>16 to less than 50 years old) were also considered as a potentially exposed or susceptible subpopulation as specified in Section 2.4.1.1. In Appendix E.8, EPA presents a discussion and analysis of workers, including adolescents, by industry sector.

2. Consumers associated with consumer use/exposure. HBCD has been identified as being used in products to which consumers may be exposed; however, only some individuals within the general population may use these products. Therefore, those who do use these products are a potentially exposed or susceptible subpopulation due to greater exposure. A description of the exposure assessment for consumers is available in Section 2.4.4.
3. Subsistence fishers. Subsistence fishers ingest substantially more fish than the average member of the general population and therefore experience much greater HBCD exposure via fish ingestion. Aggregate exposure estimates for subsistence fishers are derived and described in Section 2.4.2.5.
4. Highly exposed general population. Other groups of individuals within the general population may be more highly exposed due to their proximity to conditions of use identified in Section 1.2 and Section 2.4.2.1 that result in releases to the environment and subsequent exposures (*e.g.*, individuals who live or work near manufacturing, processing, distribution, use or disposal sites).

Section 2.4.3 provides an overview of types of receptors and exposure descriptors within the highly exposed general population. EPA estimated age-specific exposures and doses for each overall exposure group (Section 2.4.3.4) and acknowledges that individuals among the highly exposed general population and other PESS categories overlap, as some individuals may belong to multiple receptor groups (as described in Table 2-71). EPA also estimated ambient air concentrations for the highly exposed general population, covering individuals of all lifestages living near facilities. Further characterization about highly-exposed group and associated variability of exposure factors within the highly-exposed group is discussed in the *Risk Evaluation for Cyclic Aliphatic Bromide Cluster (HBCD), Supplemental Information on General Population, Environmental, and Consumer Exposure Assessment*.

In developing exposure scenarios, EPA considered age-specific differences (Section 2.4.2.1). For HBCD, exposure scenarios that involve potentially exposed or susceptible subpopulations considered age-specific behaviors, activity patterns, and exposure factors unique to those subpopulations. EPA used the Exposure Factors Handbook ([U.S. EPA 2011b](#)) to inform body weights and intake rates for children and adults also described in the *Supplemental Information on General Population, Environmental, and Consumer Exposure Assessment*. Sections 2.4.2.2, 2.4.3.1, and 2.4.4.1 provide an overview of exposure pathways considered for the different age groups.

There are some exposure scenarios where greater exposure from multiple sources may occur and individuals who may have greater potential for exposure to HBCD. For example, as part of the Risk Evaluation:

5. EPA used the CHAD database to inform how much time children spend in microenvironments (Section 2.4.2.2.3) to determine children with elevated dust concentrations (Sections 2.4.4.2 and 2.4.4.3).
6. EPA considered breast milk concentration data and ingestion for breast-fed infants (< 1 year old) in the exposure estimation (Section 2.4.2.3).
7. EPA used an activity-pattern based method to model hand-to-mouth and object-to-mouth contact and to derive transfer rates of soil and dust to the mouth to estimate ingestion rate for children

and/or adults who ingest soil or sediment in environments where HBCD concentrations are elevated (Sections 2.4.2.2.2 and 2.4.2.2.3), and for children who may mouth objects containing HBCD (Section 2.4.4.4).

8. EPA completed an assessment of human dietary exposure from multiple sources for children or adults who consume edible aquatic biota or terrestrial biota containing elevated levels of HBCD. EPA considered available biomonitoring data in wildlife and dietary patterns across trophic levels as part of its exposure assessment. These approaches were considered together to determine HBCD concentrations in surface water, sediment, soil, and targeted wildlife biota. See Section 2.4.2.2.1 for detailed information.

EPA also considered and analyzed the available data to ascertain whether some human receptor groups may be exposed via pathways that may be distinct to a particular subpopulation or lifestage (*e.g.*, children's crawling, mouthing or hand-to-mouth behaviors, see Appendix E) and whether some human receptor groups may have higher exposure via identified pathways of exposure due to unique characteristics (*e.g.*, activities, duration or location of exposure) when compared with the general population ([U.S. EPA 2006](#)).

3 HAZARDS

3.1 Environmental Hazards

3.1.1 Approach and Methodology

During scoping and problem formulation, EPA reviewed potential environmental and health hazards associated with HBCD. EPA identified the following sources of environmental hazard data: Technical Review of HBCD ([U.S. EPA 2016e](#)), Technical Review of Flame Retardant Alternatives for HBCD ([U.S. EPA 2014d](#)), National Industrial Chemicals Notification and Assessment Scheme (NICNAS) Report on HBCD: Priority Existing Chemical Assessment ([NICNAS 2012a](#)), Environment Canada and Health Canada Screening Assessment Report on HBCD ([EC/HC 2011](#)), European Union (EU) Environmental Risk Assessment on HBCD ([EINECS 2008](#)), EPA Risk-based Prioritization of HPV Chemicals ([U.S. EPA 2008a](#)), and SIDS Assessment of HBCD ([OECD 2007](#)). These sources describe the hazards of HBCD to aquatic organisms including fish, aquatic invertebrates, aquatic plants and sediment invertebrates exposed to relevant media under acute and chronic exposure conditions. These publications report acute toxicity to aquatic invertebrates from HBCD, based on mortality and immobilization as well as chronic toxicity to aquatic invertebrates (growth and reproduction) when exposed to HBCD. Also, chronic toxicity was observed in benthic organisms based on reduced survivability when exposed to HBCD. In addition, these assessments summarize the hazards of HBCD to terrestrial organisms including soil invertebrates and avian species when exposed to relevant media under acute and chronic exposure conditions.

Although the assessment documents mentioned above provide detailed information regarding the environmental hazard of HBCD to aquatic and terrestrial organisms, they do not account for additional and latest information published on HBCD. Therefore, EPA completed the review of environmental hazard data/information sources during Risk Evaluation using the data quality review evaluation metrics and the rating criteria described in the [Application of Systematic Review in TSCA Risk Evaluations](#) document ([U.S. EPA 2018b](#)). Studies that were considered “On Topic” were evaluated for acceptability. The acceptable studies were rated as high, medium, or low for quality. The data quality evaluation results are outlined in [Supplemental File: Data Quality Evaluation of Environmental Hazard Studies](#) ([U.S. EPA 2019k](#)). With the data, only studies rated as high, medium, or low for quality during data evaluation were used during data integration. Any study rated as unacceptable was not used. Also, only clearly adverse signs of toxicity (*e.g.*, lethality, immobility, effects on growth and reproduction, organ histopathology, abnormal behavior) were used to set toxicity effect levels such as lethal and effective concentrations (*i.e.*, LC₅₀, EC₅₀ values) no-observed-effect concentrations (NOECs) and lowest-observed-effect concentrations (LOECs).

3.1.2 Hazard Identification

EPA identified 50 acceptable studies (*i.e.*, rated high, medium or low) that contained aquatic toxicity data (*i.e.*, fish, aquatic invertebrates, algae) and terrestrial toxicity data (*i.e.*, plants, earthworms, avian species). Aquatic toxicity studies considered in this assessment are summarized in Table 3-1

This assessment evaluated not only studies that followed standard test guidelines (*e.g.*, Office of Chemical Safety and Pollution Prevention (OCSPP)), Organisation for Economic Co-operation and Development [OECD]), but also non-standard toxicity tests that followed procedures that were scientifically sound according to the [Application of Systematic Review in TSCA Risk Evaluations](#) document ([U.S. EPA 2018b](#)). For this assessment, adverse signs of toxicity (*e.g.*, lethality, immobility,

effects on growth and reproduction, organ histopathology, abnormal behavior) were used to set toxicity thresholds.

Table 3-1. Environmental Hazard Characterization of HBCD to Aquatic and Terrestrial Organisms

Test Organism	Duration	Endpoint	Hazard Value	Units	Effect Endpoint	Reference
<i>Aquatic Organisms</i>						
Fish	Acute	96-hour LC ₅₀	>0.0025	mg/L	No effects on growth and mortality	(Wildlife Intl 1997b) (High)
		96-hour LOAEL	0.002	mg/L	Hatch delay	(Hu et al., 2009a) (High)
	Chronic	88-day NOEC	>0.0037	mg/L	No effects on growth, reproduction or survival	(Drottar et al. 2001) (High)
		168-day	>0.02284	mg/kg (diet)	disrupted thyroid homeostasis	(Palace et al., 2008; Palace, et al., 2010) (High)
		42-day	>0.5	mg/L	No effects on growth and mortality	(Zhang et al., 2008) (High)
		34-day NOEC	> 0.250	mg/L	No effects on growth and mortality	(Foekema et al. 2014) (High)
		78-day LOAEL	0.3	mg/kg (lipid diet)	Thyroid effects	(Kuiper et al., 2007) (High)
Sub-chronic	17-day	50	mg/L	Abnormal growth, malformation	(Hong et al., 2014) (High)	
Amphibians	Acute	8-day EC ₅₀	0.064	mg/L	Tail tip regression	(Schriks, 2006) (High)
Invertebrates (Pelagic)	Acute	48-hour EC ₅₀	>0.0032	mg/L	Immobilization	(Wildlife Intl 1998; Wildlife Intl LTD 1997) (High)
		96-hour LC ₅₀	>0.8	mg/L	Mortality	(Shi et al. 2017a) (High)
	Chronic	21-day NOEC	0.0031	mg/L	Reproduction; Growth (weight and length)	(Wildlife Intl 1998) (High)
		21-day LOEC	0.0056	mg/L		
		21-day MATC	0.0042	mg/L		
Invertebrates (Benthic)	Chronic	28-day LOEC	>1,000	mg/kg dw	Mortality	(ACC 2003a, b) (High)
		28-day NOEC	3.1 ^a	mg/kg dw	Population	(Oetken et al. 2001) (High)
		28-day NOEC	8.6 ^b	mg/kg dw	Population	
		28-day LOEC	28.7	mg/kg dw	Population	
		28-day MATC	15.7	mg/kg dw	Population	
Algae ^c		96-hour EC ₅₀	>0.0037	mg/L	Growth	(Wildlife Intl 1997b) (High)
		72-hour EC ₅₀	0.08	mg/L	Growth	(Walsh et al. 1987) (High)
		72-hour EC ₅₀	>0.041	mg/L	Growth	(Desjardins et al. 2004) (High)
		72-hour EC ₁₀	0.041	mg/L	Growth	
		72-hour EC ₅₀	0.052	mg/L	Growth	(Desjardins et al. 2005) (High)
		72-hour EC ₅₀	>0.01	mg/L	Growth	
<i>Terrestrial Organisms</i>						
Vegetation	Short-term	96-hour NOEC	>5,000	mg/kg dw	Emergence; Mortality; Growth	(Wu et al. 2016c; Wu et al. 2012; Porch et al. 2002) (High)

Test Organism	Duration	Endpoint	Hazard Value	Units	Effect Endpoint	Reference		
	Chronic	21-day NOEC	>5,000	mg/kg dw	Emergence; Mortality; Growth	(Wu et al. 2016c ; Wu et al. 2012 ; Porch et al. 2002) (High)		
Invertebrates	Chronic	56-day EC ₁₀	21.6	mg/kg soil	Effects not reported Reproduction; Mortality	(Aufferheide et al. 2003) (High)		
		28-day NOEC	128	mg/kg soil				
		56-day NOEC	128	mg/kg soil	Reproduction			
		56-day LOEC	235	mg/kg soil				
		56-day LOEC	> 4,190	mg/kg soil			Mortality	
Avian Species	Chronic	22-day LOEC	0.001	mg/kg-d	Pipping success	(Crump et al. 2010) (High)		
		6-week LOAEL	125	µg/L	Hatching success	(MOEJ 2009) (High)		
			15	mg/L	Offspring survival			
			2.1	mg/kg-d				
			5	mg/L				
		75-day LOAEL	164.3	ng/g egg ww	Corticosterone response in males; Flying activities in juvenile males; Predator avoidance in juvenile females	(Kobiliris 2010) (High)		
		21-day LOAEL	0.51 - 3.27	mg/kg-d	Delayed egg laying of smaller eggs with thinner eggshells	(Martinson et al. 2012 ; Ferne et al. 2011 ; Martinson et al. 2011 ; Martinson et al. 2010) (High)		
		<p>a Toxicity value reported by author.</p> <p>b Toxicity value reported by author (normalized to organic carbon content in sediment).</p> <p>c Because algae can cycle through several generations in hours to days, the data for algae was assessed together regardless of duration (<i>i.e.</i>, 48-hrs to 96 hrs). Values in bold were used to derive Concentrations of Concern (COC) as described in Section 3.1.5 of this document. All values are listed individually with study quality in [Data Quality Evaluation of Environmental Hazard Studies and Data Extraction for Environmental Hazard Studies. Docket: EPA-HQ-OPPT-2019-0500].</p>						

3.1.2.1 Aquatic Toxicity

Acute Fish Toxicity

Short-term effects of HBCD to fish were identified in six acceptable studies representing different species including, rainbow trout (*Oncorhynchus mykiss*), zebrafish (*Danio rerio*) and Indian medaka (*Oryzias melastigma*).

During an 96-hour acute toxicity study, rainbow trout (*O. mykiss*) were exposed to HBCD composed of α , β , and γ - diastereomers under flow-through conditions ([Wildlife Intl 1997b](#)). Rainbow trout (*O. mykiss*) were exposed to six measured concentrations between 0 and 0.0025 mg/L. However no mortalities or other effects were observed throughout the test. The results indicate that HBCD is not acutely toxic to rainbow trout (*O. mykiss*) up to concentrations of >0.0025 mg/L. Other studies reported adverse effects on the embryo toxicity (*i.e.*, hatching, heart rate, development) of HBCD exposure. However, most of these studies reported effects above HBCD's water solubility limit. In an embryo toxicity study in zebrafish (*D. rerio*) conducted by [Hu et al., \(2009a\)](#), delayed hatching was observed at 0.002 mg/L at 96-hours post fertilization, but not at the two highest exposure concentrations of 2.5 and 10 mg/L. Hatching success was not affected at any concentrations. In addition, no effects on survival or malformation rates were observed in embryos exposed to concentrations up to 10 mg/L (highest concentration tested). Other effects such as increase in heat shock protein at 0.01 mg/L and an increase in malondialdehyde activity, used as a measure of lipid peroxidation, at 0.5 mg/L were observed. The activity of superoxide dismutase was increased at 0.1 mg/L but decreased at 2.5 and 10 mg/L. The

author concluded that HBCD can cause oxidative stress and overexpression of Hsp70 in acute exposures of zebrafish embryos.

Chronic Fish Toxicity

One acceptable study represents the chronic effects of HBCD to fish. In this study ([Wildlife Intl 1997b](#)), rainbow trout (*O. mykiss*) were exposed to HBCD at mean measured concentrations of 0.00025, 0.00047, 0.00083, 0.0018, and 0.0037 mg/L under flow-through conditions for 88 days. Reagent grade acetone was used as a solvent control. The maximum nominal concentration was similar to the measured water solubility of 0.0086 mg/L. No effects were found at the water solubility limit of HBCD. The reported 88-day NOEC was >0.0037 mg/L. There were other studies that conducted sub-chronic or chronic exposures of HBCD to fish and are summarized in the Risk Evaluation for Cyclic Aliphatic Bromide Cluster (HBCD), *Systematic Review Supplemental File: Data Extraction Tables of Environmental Hazard Studies* ([U.S. EPA 2019b](#)). These other studies reported effects of chronic exposure to HBCD including increased malformation rate, developmental abnormalities, oxidative stress and apoptosis ([Hong et al., 2014a](#)), thyroid effects (Palace et al., [2008](#), [2010](#)), oxidative damage to lipids, proteins, and DNA and decreased antioxidant capacities in fish tissue ([Zhang et al., 2008](#)). Hong et al. ([2014a](#)), examined the effects of HBCD on embryos of the marine medaka (*Oryzias melastigma*). The embryos were exposed to HBCD for 17 days in an early life stage test. The developmental abnormalities in medaka included yolk sac edema, pericardial edema, and spinal curvature. Mechanistic findings in this study included increases in heart rate and sinus venosus-bulbus arteriosus (SV-BA) distance, which are markers for cardiac development, induction of oxidative stress and apoptosis, and suppression of nucleotide and protein synthesis. A maximum acceptable toxicant concentration (MATC) of 0.03 mg/L was reported for this study. In contrast, Foekema et al. ([2014](#)) observed no effects on mortality or development through metamorphosis (approximately 40 days post-fertilization) in sole (*Solea solea*) embryos exposed in an early life stage test to concentrations of HBCD up to 0.25 mg/L for 6 days, starting at 12 hours post-fertilization.

In other studies, thyroid effects were reported in juvenile rainbow trout (*O. mykiss*) following dietary exposure to HBCD (Palace et al., [2008](#), [2010](#)). Each of the diastereomers of HBCD (administered separately via diet at concentrations of 5 ng/g of α -, β -, or γ -HBCD for up to 56 days) disrupted thyroid homeostasis, as indicated by lower free circulating T3 and T4 levels. No thyroid or other effects were observed in European flounder (*Platichthys flesus*) following 78 days of diet or sediment exposure to maximum concentrations of 3,000 μ g/g lipid in food and 8,000 μ g HBCD/g total organic carbon (TOC) ([Kuiper et al., 2007](#)).

Acute Invertebrate Toxicity

There are three acceptable studies that represent the acute toxicity of HBCD to aquatic invertebrates. These studies include two water flea (*Daphnia magna*) studies and one copepod (*Tigriopus japonicus*) study. The results of these acceptable studies show that HBCD is not acutely toxic to aquatic invertebrates at the chemical's water solubility limit.

In one study ([Wildlife Intl 1997](#)), *D. magna* were exposed to mean measured concentrations of 0, 0.0018, 0.0021, 0.0023, 0.0024, and 0.0032 mg/L under flow-through conditions for 48 hours. No effects were observed at the highest exposure concentration. In another study ([Wildlife Intl 1998](#)), The water flea (*D. magna*) were exposed to mean measured concentrations of 0, 0.00087, 0.0016, 0.0031, 0.0056, and 0.011 mg/L for 21 days under flow-through conditions. No effects on mortality or immobilization were observed at the highest exposure concentration after 48 hours of exposure to HBCD. Both studies suggest that acute exposures to concentrations of HBCD below the HBCD water

solubility did not result in measured effects on mortality or immobilization behavior in *D. magna*. Finally, the copepod (*T. japonicus*) were exposed to measured concentrations of 0, 0.008, 0.03, 0.08, 0.3, and 0.8 mg/L of HBCD for 96-hours ([Shi et al. 2017a](#)). Although the exposure concentrations were tested above the water solubility limit, a solvent control (DMSO) was used. No effects were observed at the highest exposure concentration.

Chronic Invertebrate Toxicity

There are four high-quality studies that represent the chronic toxicity of HBCD to aquatic invertebrates representing freshwater and saltwater species in the water and sediment compartments. These studies included one water flea (*D. magna*) study, two amphipod (*Hyalella azteca*) studies, one black worm (*Lumbriculus variegatus*) study and one copepod (*Tigriopus japonicus*) study. There were effects on growth and reproduction in the water flea (*D. magna*) after 21 days of exposure to HBCD. The organisms were exposed to mean-measured concentration of 0, 0.00087, 0.0016, 0.0031, 0.0056, and 0.011 mg/L HBCD under flow-through conditions ([Wildlife Intl 1998](#)). An MATC of 0.042 mg/L was calculated from a NOEC of 0.0056 mg/L and a LOEC of 0.031 mg/L. Also, there were effects on the survival in the black worm (*L. variegatus*) after exposures to 0.05, 0.5, 50, and 500 mg/kg dry weight (dwt) in sediment HBCD for 28-days ([Oetken et al. 2001](#)). The effects are relevant at the population level. In addition, HBCD induced developmental delay after 40 days of exposure to *T. japonicus* ([Shi et al. 2017a](#)). Marine copepods were exposed to nominal concentrations of 0, 0.008, 0.03, 0.08, 0.3, 0.8 mg/L in water under static conditions. DMSO was used as a solvent. After 20 days of exposure, HBCD caused growth delay to the copepod (*T. japonicus nauplii*). The LOEC for developmental delay (from the nauplii to copepodid) were 0.03 and 0.008 mg/L for the F₀ and F₁ generations, respectively. Similarly, the LOEC for developmental delay (nauplii to adults) were 0.3 and 0.03 mg/L for the F₀ and F₁ generations, respectively, suggesting that the F₁ generation was more sensitive to HBCD than the F₀ generation. For the water flea (*H. azteca*) no effects were observed at exposures of 31, 63, 125, 250, 500, and 1,000 mg/kg dw sediment (nominal concentrations) HBCD for 28 days in the presence of 2% and 5% TOC ([ACC 2003a, b](#)).

Other Acute and Chronic Effects

A wide range of effects of HBCD have been reported in fish (*e.g.*, developmental toxicity, embryo malformations, reduced hatching success, reduced growth, hepatic enzyme and biomarker effects, thyroid effects, DNA damage to erythrocytes, and oxidative damage) and invertebrates (*e.g.*, degenerative changes, morphological abnormalities, decreased hatching success, and altered enzyme activity) in supporting studies that assessed endpoints beyond those evaluated in this assessment ([Du et al. 2015](#); [Hong et al. 2015](#); [Foekema et al. 2014](#); [Hong et al. 2014](#); [Zhang et al. 2014a](#); [Wu et al. 2013](#); [Du et al. 2012a](#); [Anselmo et al. 2011](#); [Palace et al. 2010](#); [Deng et al. 2009](#); [Hu et al. 2009a](#); [Smolarz and Berger 2009](#); [Aniagu et al. 2008](#); [Palace et al. 2008](#); [Zhang et al. 2008](#); [Ronisz et al. 2004](#)). Effects on the thyroid in rainbow trout (*O. mykiss*) (reduced thyroid hormone (triiodothyronine, T₃, and thyroxine, T₄) ([Palace et al. 2010](#); [Palace et al. 2008](#); [Kuiper et al. 2007](#); [Lower and Moore 2007](#)), are similar to those observed in mammals. These studies were evaluated using metrics and the rating criteria described in the Application of Systematic Review in TSCA Risk Evaluations document ([U.S. EPA 2018b](#)). These studies were considered acceptable and are summarized in the *Risk Evaluation for Cyclic Aliphatic Bromide Cluster (HBCD)*, *Systematic Review Supplemental File: Data Extraction Tables of Environmental Hazard Studies* document ([U.S. EPA 2019b](#)).

Amphibians

For amphibians, one acceptable high quality study reported data on species of African clawed frog (*Xenopus laevis*.)

Schriks et al. (2006) conducted a metamorphosis bioassay in the African clawed frog (*X. laevis*) to detect thyroid hormone disruptive effects by HBCD. Pre-metamorphic *X. laevis* tadpoles were pre-treated with the goitrogen methimazole to inhibit thyroid synthesis prior to isolation of tadpole tips (6-8 mm). The tadpole tips were cultured *ex vivo* in dishes for 24 hours, and thereafter exposed to DMSO (solvent control) and 6.4 mg/L of HBCD. On day 6, exposure of tail tips to 6.4 mg/L HBCD in combination with 20 nM of T₃, significantly ($p \leq 0.05$) potentiated tail tip regression with $35 \pm 5\%$. All lower HBCD exposures, including HBCD alone (0.64 mg/L), did not have any effects on tail tip regression. At 6.4 mg/L HBCD alone or in combination with 20 nM T₃ resulted in a very fast regression of tail tips in the first two days of exposure. This was faster than tail tip regression in the 100 nM T₃-control, but after two days of exposure tail tip regression roughly stayed the same during the rest of the experiment period. The study concluded that this fast regression was due to cytotoxic activity at this concentration.

Aquatic Vegetation Toxicity

For aquatic plants hazard studies, algae are the common test species. Algae are cellular organisms which will cycle through several generations in hours to days; therefore, the data for algae was assessed together regardless of duration rather than being categorized as acute or chronic. There were five acceptable studies for three species of algae (green algae and diatoms), including fresh and saltwater species. Population changes were reported in the marine diatom (*Skeletonema costatum*) after 72 hours exposure to HBCD (Walsh et al. 1987). The EC₅₀ values were determined in four of the five test media with different salinity for the marine diatom (*S. costatum*) and ranged from 0.009 to 0.012 mg/L. The geometric mean EC₅₀ was 0.010 mg/L. Also, in the same study, the green algae (*Thalassiosira pseudonana*) were exposed to HBCD under the same conditions. The EC₅₀ values were determined in all six-test media and ranged from 0.050 to 0.370 mg/L. The reported EC₅₀ value for *T. pseudonana* was 0.08 mg/L. No effects on population changes were reported at the solubility limit of HBCD for this study.

A subsequent study by Desjardins et al. (2004) supports the acute toxicity of HBCD to the marine diatom (*S. costatum*). In this study, the marine diatom (*S. costatum*) was exposed to a single test concentration of HBCD, a negative control and a media control (no generator column) for 72 hours. Measured test concentrations (as separate α , β and γ isomers) were determined from samples of test medium collected from the treatment and each control group at the beginning and end of the test. At test initiation, an inoculum of the algal cells was added to each test chamber at a concentration of 77 000 cells/mL. Samples were collected from each replicate test chamber at 24-hour intervals to determine cell densities and area under the curve (AUC) values. The arithmetic mean of total HBCD at test termination was 0.041 mg/L and consisted of mean measured test concentrations for α -, β - and γ -HBCD of 0.0305, 0.00886 and 0.161 mg/L respectively. The author reported that a concentration 0.041 mg/L resulted in approximately 10% inhibition of growth in the marine diatom (*S. costatum*) after 72 hours exposure to HBCD.

Desjardins et al. (2005) conducted another 72-hour study with *S. costatum*. This study consists of two toxicity tests with HBCD using a co-solvent and performed at saturated solution. The biomass and the growth rate were derived. For the co-solvent test, the primary stock solution was prepared in dimethylformamide (DMF) at a nominal concentration of 0.10 mg/ml and diluted to secondary stock solutions. Aliquots of the stock solutions were diluted with saltwater medium to prepare the nominal concentrations of 0.00064, 0.0016, 0.004 and 0.010 mg/L. The analytical results performed at the beginning of the test corresponded to 332, 131, 94 and 108% of the nominal concentration, respectively. The solvent concentration in the solvent control and treatment groups was 0.1 ml/L. There was no

statistical difference between the control group and the test concentrations. The saturated solution test was performed to study effects on algal growth of the mixed diastereomers of HBCD at the water solubility limit. Only one test concentration was used. However, the concentrations used in the co-solvent test and the concentration used in this assay combined, meets the requirement for an adequate study. The authors mentioned that the test solution corresponded to the saturated solution of HBCD in saltwater. The mean measured concentration of HBCD as a sum of the diastereomers was 0.0545 mg/L. At the beginning of the test the following measured concentrations of the diastereomers were found: $\gamma = 0.00354$ mg/L, $\beta = 0.0152$ mg/L and $\alpha = 0.0358$ mg/L. The growth rate inhibition during the study was 17% compared to the column control after 24 hours, 29% after 48 hours and 51% after 72 hours. A non-linear regression fitting to the cumulative normal distribution was used to calculate an EC₅₀. The 72-hr EC₅₀ for biomass and growth rate was calculated to be 0.027 and 0.052 mg/L, respectively.

There was one acceptable freshwater algal study conducted with HBCD. In this study, there were no effects reported on abundances and population growth rate after 96-hour exposure to HBCD to *Selenastrum capricornutum* (currently known as *Raphidocelis subcapitata*) ([Wildlife Intl 1997b](#)). This freshwater green algae species was exposed to mean measured concentrations of 0.0013, 0.0022, 0.0033, 0.0042 and 0.0064 mg/L under static conditions for 96 hours. No dose response was found. Inhibition of around 10% based on AUC after 96-hour was observed in the highest tested treatment. Averaging the measured concentrations at the start and the end of the test for the highest exposed test group resulted in a mean exposure concentration of 0.0037 mg/L.

3.1.2.2 Terrestrial Organisms

Toxicity to Soil Invertebrates

Three acceptable studies reported data on two species of earthworms. All three studies were rated as high-quality. [Aufderheide et al. 2003](#) conducted a 56-day study where earthworms (*Eisenia fetida*) were exposed to HBCD to evaluate effects regarding reproduction and mortality. At 28-days a NOEC of 4,190 mg/kg dw soil was reported for mortality. The 56-day reproduction NOEC was 128 mg/kg dw soil.

Another study examined the bioaccumulation potential of HBCD in earthworms (*E. fetida* and *Metaphire guillelmi*) ([Li et al. 2016](#)). The tissue concentrations of α - and γ -HBCDs were substantially higher in *E. fetida* compared to those in *M. guillelmi*, with the higher lipid and protein contents in *E. fetida* as the primary reason for this difference. Other processes, such as uptake, depuration, metabolism and isomerization, also differed between the two earthworm species and led to a difference in the bioaccumulation of β -HBCD. The β - and γ -HBCDs were bioisomerized to α -HBCD in the earthworms, but to a greater extent in *E. fetida*.

[Shi et al., \(2017a\)](#) examined the effects of HBCD on the growth rate of the earthworm (*E. fetida*) exposed to nominal concentrations of 0, 50, 100, 200, and 400 mg/kg dw and control (acetone). A significant ($p < 0.01$) up-regulation of superoxide dismutase (SOD) expression level was observed in earthworms exposed to HBCD at 400 mg/kg dw soil. The transcript level of Hsp70 gene was significantly up-regulated ($p < 0.01$) when earthworms exposed to HBCD at 400 mg/kg (2.61-fold). A LOAEL of 400 mg/kg dw soil was reported.

Toxicity to Avian Species

There are 11 studies that report data for exposure to HBCD for three avian species. These studies include the domestic chicken (*Gallus domesticus*), Japanese quail (*Coturnix japonica*), and American

kestrel (*Falco sparverius*). The results of these high-rated studies show that HBCD is toxic all three avian species with reported adverse effect on body weight, reproduction, development, behavior and thyroid hormone regulation. In one study, short-term exposure to HBCD to the chicken (*G. domesticus*) at nominal concentrations of 0, 0.006, 0.06, 0.6, 1.9, and 6.4 mg/L resulted in a significant up-regulation of enzymes involved with metabolism of xenobiotic (Crump et al. 2008). Also, significant down-regulation of proteins associated with the thyroid hormone pathway and lipid regulation occurred in this concentration range. A 36-hour LOAEL of 0.06 mg/L was reported. A follow-up to this study, (Crump et al. 2010), reports the effects of HBCD on embryo toxicity, isomer-specific accumulation in liver and cerebral cortex, and hepatic gene expression in the chicken (*G. domesticus*). HBCD was injected into the air cell of chicken eggs prior to incubation. Measured concentrations of 220, 430, 1,500 (nominal), 4,980 and 50,000 (nominal) mg/L were used. Nominal concentrations were noted because the measured concentrations for 300 and 10,000 ng/g could not be quantified. In addition, the authors reported the effect concentrations based on the nominal stock concentrations. Eggs were observed for pipping success for 22 days. Reduced pipping success was observed at 100 and 10,000 ng/g HBCD. Also, isomeric composition of HBCD was significantly altered in hepatic tissue at 100 and 10,000 ng/g.

In another study (MOEJ 2009) adult mortality observed for the Japanese quail (*C. japonica*) increased at 1,000 mg/L. Also, dietary exposure of HBCD for *C. japonica*, resulted in reproductive toxicity (MOEJ 2009). Quails were fed diets containing 0, 17.5, 33.4, 61.5 or 126.9 mg/kg-bw/day of HBCD (a mixture of isomers: α , 27%; β , 30%; γ , 43%) for six weeks. HBCD exposure resulted in a reduction in hatchability at all concentrations examined. Statistically significant reduction in eggshell thickness ($P \leq 0.05$) was also observed at concentrations above 17.5 mg/kg/day. Also, HBCD exposure resulted in decreased egg weights and production rate and an increase in cracked eggs at the two highest exposure concentrations (61.5 mg/kg/day and 126.9 mg/kg/day). The effect on reproduction and development are relevant for population effects.

Four acceptable studies reported data on the reproductive, development and behavior effect of HBCD in American kestrels (*F. sparverius*), (Marteinson et al. 2012; Fernie et al. 2011; Marteinson et al. 2011; Kobiliris 2010; Marteinson et al. 2010).

Kobiliris (2010) reported a reduced “corticosterone response” (where “corticosterone response” was defined as a stimulation of the adrenal cortex to produce and release corticosterone into the bloodstream), reduced flying activities of juvenile males during hunting behavior trials, and delayed response times of juvenile females during predator avoidance behavior trials in American kestrels (*F. sparverius*) exposed in ovo to 164.13 ng/g wet weight (ww).

Fernie et al. (2011) examined the reproductive effects of HBCD on the American kestrels (*F. sparverius*). HBCD dissolved in safflower oil was injected into the brains of dead cockerels daily. The kestrels were fed a ration of cockerels equivalent to approximately 0.51 mg/kg-day. Dietary exposure began three weeks prior to pairing and continued through courtship, egg laying, and incubation, until the first chick hatched (approximately 75 days). Exposed kestrels laid eggs with average tissue concentrations of 163.5 ng α -HBCD/g ww, 13.9 ng β -HBCD/g ww, and 2.6 ng γ -HBCD/g ww. Exposed birds displayed reduced time from pairing to egg laying and laid larger clutches of smaller eggs (volume, mass). Exposed eggs lost more weight than control eggs during incubation, but egg shell thickness was not affected. No effect on reproductive success was identified.

In a related study, Marteinson et al. (2010) found that accidental exposure of male *in ovo* American kestrel (*F. sparverius*) to small concentrations of HBCD during exposure to pentaBDE technical formulation (DE-71) may have contributed to synergistic/additive effects. HBCD levels in male

offspring of kestrels were measured at 3.27 ± 0.68 ng/g ww (low exposure), and 15.61 ± 2.63 ng/g ww (high exposure) based on sibling eggs. HBCD levels were significantly negatively correlated with reproductive success parameters of the male offspring: clutch size, fertility, copulation and behavior. However, because PBDE levels were also significantly correlated to these parameters, the authors determined that it was difficult to separate the influences of HBCD from those of PBDE.

In a subsequent study, Marteinson et al. (2011) exposed the American kestrel (*F. sparverius*) to dietary HBCD at 0.51 mg/kg bw-day and found increased testes weight in unpaired males, an effect on testis histology in unpaired males (increased number of seminiferous tubules containing elongated spermatids; $p = 0.052$), marginally increased testosterone levels in breeding males (increased at the time the first egg was laid; $p = 0.054$), and no significant effect on sperm counts. Plasma T4 levels were reduced in breeding males throughout the study, which the authors suggest that the thyroid disruption may have contributed to the observed increase in testes weight.

Toxicity to Terrestrial Mammals

The toxicity of HBCD to mammals is characterized in Section 3.2 of this document. In rodents, HBCD isomers are biotransformed in the liver and are distributed in fat, liver, skeletal muscle and skin. Oral toxicity studies in rodents show that HBCD exposure can affect thyroid function. HBCD exposure can result in liver weight, steatosis, hypertrophy and inflammation. Reproductive toxicity in female rats included decreases in pregnancy, number of litters lost at high exposure dose to F1 dams and decrease primordial follicles. In male rats, no consistent effects were found relating reproductive effects to HBCD exposures. HBCD exposure to rats resulted developmental effects including reduced offspring viability, decreased pup body weight, altered development and skeletal system, and delayed eye opening. Neurological effects as reported in experimental studies in rats resulted in neurodevelopmental milestones, locomotor activity and executive function and neurological outcomes related to changes in auditory sensitivity, dopamine system function, and brain weight. Immune system effects in rats exposed to HBCD during development also resulted in changes to organ weights.

Toxicity to Terrestrial Vegetation

For terrestrial plants, three acceptable studies reported data on six species. All studies have a high-quality rating. Phytotoxicity was reported in a 21-day exposure to HBCD to six species of plants (Porch et al. 2002). Mean measured test concentrations were 31.2, 97.7, 297.1, 764.6, 2,230 and 6,200 mg/kg dry weight. In one study, three monocots (corn, onion and rye grass) and three dicots (cucumber, soybean and tomato) were tested. For each species, a control group, and the five treatments were maintained. Each group consisted of four replicates each containing 10 seeds. During the 21-day test, weekly observations of seedling emergence and a qualitative assessment of the condition of each seedling were made. Onions exposed to 276 mg/kg HBCD resulted in significant ($p < 0.05$) reductions in mortality. There were no signs of treatment-related phytotoxicity observed on seedlings of any species at any test concentration. In another study, the accumulation and toxicity of α , β , and γ -HBCDs in maize were examined after exposure of 0, 0.002, 0.005, 0.01, 0.02, and 0.05 mg/L (Wu et al. 2012). In another study, Wu et al. (2016c) investigated the accumulation of HBCD in maize. Young seedlings were exposed to HBCD at concentrations of 0, 0.002, 0.005, 0.01, 0.02, and 0.05 mg/L. The uptake kinetics showed that the HBCD concentration reached an apparent equilibrium within 96 hours, and the accumulation was much higher in roots than in shoots. A reduction in maize root and shoot growth resulted from an exposure to 0.002 mg HBCD/L.

3.1.3 HBCD Trophic Transfer in the Environment

EPA initially assessed the PBT characteristics of HBCD in accordance with the U.S. EPA TSCA Work Plan Chemicals: Methods Document (U.S. EPA 2012d). The potential of HBCD trophic transfer in both

aquatic and terrestrial ecosystems was evaluated in this Risk Evaluation by using the *U.S. EPA Final Water Quality Guidance for Great Lakes System* ([U.S. EPA 1995](#)), *U.S. EPA Wildlife Exposure Factors Handbook* ([U.S. EPA 1993b](#)) and European Chemicals Agency (ECHA) Guidance on Information Requirements and Chemical Safety Assessment (Chapter R.16: Environmental exposure estimate; ECHA, 2016). Ingestion rates from the *U.S. EPA Wildlife Exposure Factors Handbook* ([U.S. EPA 1993b](#)) are used to estimate the exposure of both aquatic and terrestrial predatorial organisms; the same ingestion rates for aquatic organisms are also used in the *U.S. EPA Final Water Quality Guidance for Great Lakes System* ([U.S. EPA 1995](#)). Different methodologies of predicting potential HBCD trophic transfer were utilized because each method focuses on predators with different feeding habits; organisms were chosen for each of the methods based on data availability and method-specific requirements.

EPA has assessed the available studies collected in accordance with *The Application of Systematic Review in TSCA Risk Evaluations* ([U.S. EPA 2018b](#)) relating to the bioaccumulation and bioconcentration (BAF/BCF) of HBCD. To evaluate HBCD uptake via dietary and media exposure, different approaches were used to incorporate various sources (*i.e.*, environmental monitoring and modeled surface water and sediment concentrations) and types of exposure media (*i.e.*, uptake via diet or environmental media). The calculations used to predict HBCD trophic transfer for both the aquatic (mink and osprey) and terrestrial (American kestrel) predators are provided in Appendix H.2. Estimations for HBCD trophic transfer as presented in Table 3-2 were calculated using exposure factors from the *U.S. EPA Wildlife Exposure Factors Handbook* ([U.S. EPA 1993b](#)) and HBCD biomonitoring data.

HBCD bioaccumulation in both aquatic and terrestrial ecosystems has been demonstrated, as detailed above in Section 2.1.2. Specifically, BAFs and BCFs up to 50,000,000 and 18,100 for HBCD have been measured for freshwater fish ([He et al., 2013](#); [Veith et al., 1979](#)), and HBCD has been ubiquitously measured in taxa spanning all trophic levels in aquatic ecosystems ([Wu et al., 2011](#)). There is a greater likelihood of the release of HBCD from the modeled exposure scenarios and respective conditions of uses into surface water, thus higher trophic level organisms that reside in and primarily consume aquatic prey have the greatest potential for exposure to and bioaccumulation of HBCD. Despite limited data regarding HBCD exposure and hazard for terrestrial organisms, the presence of HBCD in the tissue, eggs (*e.g.*, peregrine falcons and chickens) and milk of (*e.g.*, bobcats) higher biologically-organized terrestrial organisms suggest the exposure of HBCD through trophic transfer and the likelihood of sex-specific transfer of HBCD to offspring ([Boyles et al. 2017](#); [Tao et al. 2016](#); [Guerra et al. 2012](#)).

Mink (*Neovison vison*) was selected as a model aquatic predator because they primarily consume aquatic prey, specifically higher trophic level fish. American kestrel (*F. sparverius*) was selected as a model terrestrial avian predator because they primarily consume prey that inhabit terrestrial ecosystems. American kestrel serve as a terrestrial predator avian counterpart to mammals (mink), where the dietary exposures of HBCD from either only terrestrial and aquatic prey, respectively, can be compared. Mink was selected to represent a higher trophic level mammal because a majority of their diet is composed of fish and other aquatic prey. Specifically mink diet consists of 56, 26, 3, and 4% of trout, non-trout fish, unidentified fish, and crustaceans ([U.S. EPA 1993b](#)), respectively. This dietary composition is comparable to the 90% of mink diet attributed to aquatic prey in trophic level 3 ([U.S. EPA 1995](#)). The components of American kestrel diet are not as well categorized as that of mink, however approximately 31% consists of small rodents ([U.S. EPA 1993b](#)). The assessment does not assume that the remaining 10 and 69% of mink and American kestrel diet, respectively, has HBCD, and this is one of the uncertainties that may underestimate high trophic level organism exposure to HBCD via diet. Despite HBCD being found predominantly in aquatic media (*e.g.*, sediment), HBCD trophic transfer may result in HBCD

source fluxes between aquatic and terrestrial ecosystems. Specifically, HBCD source movement from aquatic to terrestrial ecosystems, via trophic transfer, is another area that was briefly explored by estimating HBCD trophic transfer to a terrestrial mammal (*e.g.*, mink) that primarily consumes aquatic prey (*e.g.*, trout) ([U.S. EPA 1993b](#)). However, despite there being available data on general categories of prey that mink, American kestrel, and osprey may consume, the dietary uptake of HBCD estimated for these predators ultimately depends on the availability of both lab and field-acquired HBCD tissue concentration data.

Given the higher likelihood that HBCD is present in the environment due to its persistent and bioaccumulative characteristics, chronic exposures are of greater relevance to higher trophic level organisms. The currently available data on HBCD toxicity to higher trophic level organisms are limited to a few avian species that do not consume prey from aquatic ecosystems (*i.e.*, Japanese quail and American kestrel), where the greatest releases of HBCD are expected. Therefore allometric scaling of the American kestrel reproductive LOEC (70,380 ng/d) was conducted to extrapolate toxicologically equivalent doses of orally administered HBCD from adult female American kestrels to adult female ospreys ([Ferne et al. 2011](#)); the methodology is detailed in Appendix H.2. There is uncertainty as to whether allometric scaling, derived from data on the results of American kestrel chronic exposure to HBCD, will hold when extrapolating to doses in osprey. This uncertainty arises because of the absence of quantitative information to characterize the toxicokinetic and toxicodynamic differences between two avian species with very different lifestages and dietary preferences. No assessment factor was used in addition to the allometric scaling of the adult female kestrel LOEC of 510 ng/g bw-d to the adult female osprey LOEC of 40.8 ng/g bw-d ([Ferne et al. 2011](#)), or the consumption of 70,380 ng HBCD/d (calculations available in Appendix H.2). The potential trophic transfer of HBCD from aquatic ecosystems is more easily estimated than that from terrestrial ecosystems due to the greater amount of both environmental and biomonitoring information and hazard data for aquatic ecosystems and organisms, respectively.

The *ECHA Guidance on Information Requirements and Chemical Safety Assessment* (Chapter R.16: Environmental Exposure Estimate) ([ECHA 2008a](#)) was used to estimate HBCD uptake via fish- and earthworm-consuming predators. Rainbow trout and earthworm bioconcentration factors (BCF) and HBCD exposure concentrations in water and soil, respectively, were used to derive C_{organism} values, as presented in Table 3-3. The BCF for rainbow trout was used to remain consistent with taxa used in Table 3-2, despite the availability of more conservative BCFs for other fish species (*e.g.*, fathead minnows). As compared to BAFs, BCFs can often underestimate HBCD uptake because only media exposure concentrations are accounted for. BCFs are used per methodologies provided in the *ECHA Guidance on Information Requirements and Chemical Safety Assessment* ([ECHA 2008a](#)). The body burden of HBCD in rainbow trout and earthworms, as presented in Table 3-3 does not represent the predicted environmental concentration in food $PEC_{\text{oral, predator}}$ for predators of rainbow trout or earthworms, respectively. Total HBCD BMFs for rainbow trout and earthworms were unavailable, and isomer-specific HBCD BMFs for rainbow trout were not used to derive $PEC_{\text{oral, predator}}$ for predators of rainbow trout because of uncertainties due to processes (*i.e.*, bioisomerization, degradation) that would significantly impact HBCD isomer uptake and depuration. There is additional uncertainty due to the use of BCFs that are not normalized to the amount of lipids present in the samples of tissues used for the referenced studies; there is additional uncertainty in using earthworms and rainbow trout as representative organisms for their respective trophic levels using this analysis as lipid normalization generally accounts for species differences (*i.e.*, size, age, seasonal variations in diet, sex).

The above-mentioned methodologies used to estimate HBCD uptake via prey consumption and media exposure only use available biomonitoring and hazard data. As compared to biomonitoring and environmental monitoring data, which provides a snapshot of real time information on HBCD concentrations found in wildlife and various media, these data cannot be specifically attributed to a condition of use of HBCD that is evaluated in this risk assessment. As described below in Section 4.1, a two-tiered approach was used to predict HBCD concentrations in various compartments (*i.e.*, surface water, pore water, sediment) as a result of HBCD releases expected from different model sub-exposure scenarios of each condition of use. In Section 2.2, the terminology of “surface water” release is used to describe release scenarios where HBCD is released into surface water without any treatment processes being used, whereas “POTW” and “WWTP” both indicate the implementation of some type of wastewater treatment process occurring before the effluent is released into the environment. In Section 3.1 (Environmental Hazards), and 4.1 (Environmental Risk), the terminology of “direct release” will be used to describe the release of HBCD into surface water without the implementation of a wastewater treatment process. “Surface water” concentrations reflect modeled surface water concentrations from HBCD release scenarios regardless of wastewater treatment processes because ultimately all three release scenarios (direct release, POTW, and WWTP) result in the release of HBCD surface water.

In addition to the HBCD concentrations predicted to be in each of the compartments using the Point Source Calculator (PSC), HBCD physical chemical properties (*i.e.*, $K_{oc}=100,000$; $\log K_{ow}=5.62$; Water solubility=66 $\mu\text{g/L}$) were used as input parameters for the K_{ow} (based) Aquatic BioAccumulation Model (KABAM) version 1.0 ([U.S. EPA 2009c](#)), which estimates the bioconcentration, bioaccumulation, and biomagnification of HBCD in aquatic food webs. Specifically, mammal and avian uptake of HBCD through diet and water intake were estimated and attributed to predicted surface water, pore water, and sediment concentrations for modeled sub-exposure scenarios 3.3 (Processing: Manufacturing of XPS Foam using XPS Masterbatch) and 5.7 (Processing: Manufacturing of EPS Foam from Imported EPS Resin beads). As explained below in Section 4.1, a sensitivity analysis was conducted to evaluate whether production volume and percent of HBCD removed from facility direct releases would impact the predicted concentrations of HBCD in various media for three modeled sub-exposure scenarios (two of which are selected for evaluation for trophic transfer) that have the highest releases of HBCD. The two model sub-exposure scenarios (3.3 and 5.7) within exposure scenarios 3 and 5 were selected because between the exposure scenarios that were targeted in the sensitivity analysis, these represent three types of water treatment of releases from facilities (*i.e.*, direct release, POTW, and WWTP) and generally have the highest predicted surface water and sediment concentrations. KABAM predictions of HBCD bioavailability through diet and water are used to categorize exposure and predict body burdens and the contribution to body burden due to diet. Predicted bioaccumulation, bioconcentration and biomagnification factors can also be predicted for representative organisms within each trophic level. American kestrel and Sprague Dawley rats are used as proxy organisms for terrestrial avian and mammalian wildlife organisms, respectively, that may be exposed to HBCD through trophic transfer and various media exposure. Specifically, for this model, based on the assumption that the modeled organisms have the same effect or response to the same effect concentration as those of the proxy organisms, hazard data on the proxy organisms are also input parameters for KABAM. All KABAM outputs (predicted body burdens, BAF, BCFs, etc.) are provided in Appendix H.3.

Methods used to estimate HBCD trophic transfer demonstrate HBCD uptake solely via prey ingestion do not account for media exposure to HBCD, whereas the use of KABAM relates potential BAF, BCFs, and other indications of trophic transfer to water releases of HBCD that can be tied to a specific COU. Environmental monitoring data, as presented above, demonstrates the higher likelihood that aquatic organisms are exposed to greater concentrations of HBCD than terrestrial organisms, especially near

facilities that process waste containing HBCD ([Zhu et al. 2017](#)). Furthermore, the data from both monitoring and modeled predictions suggest that not only can HBCD undergo trophic transfer, but that organisms that not only reside in aquatic ecosystems, but prey on aquatic organisms, will also be exposed to HBCD. This suggests that terrestrial organisms living within close proximity to aquatic ecosystems may be exposed to HBCD through their diet. Different diastereomer profiles may also depend on diet preferences, where carnivorous fish may have higher ratios of α -HBCD than omnivorous species ([Hloušková et al. 2013](#)). Although not explicitly addressed in this Risk Evaluation, the potential for HBCD trophic transfer may also depend on diastereomer-specific uptake, metabolism, bioaccumulation and excretion; diastereoisomer-specific metabolism and biotransformation may account for diastereoisomer-specific accumulation observed in higher trophic level organisms ([Du et al. 2015](#)). Finally, HBCD excretion will also determine predator exposure to HBCD through prey consumption; following an aqueous exposure to 1.8 μg HBCD/L and a depuration period of 19 days, exposed rainbow trout were able to eliminate 50% of their HBCD body burden ([Drottar and Krueger 2000](#)). The approaches used below to estimate HBCD trophic transfer do not take excretion into consideration. The equations used to derive HBCD ingestion in Table 3-2 and Table 3-3 are provided in Appendix H.2.

Table 3-2. Potential Trophic Transfer of HBCD in Aquatic and Terrestrial Ecosystems Using the U.S. EPA Final Water Quality Guidance for Great Lakes System and U.S. EPA Wildlife Exposure Factors Handbook

Organism's Attribute	Assumption	Reference	Amount of HBCD Consumed per Day	Amount of HBCD Consumed per day Normalized to Body Weight
Deer mouse ingestion rate (female)	0.45 g food/ g bw-d	Millar, 1979 ¹	Deer Mouse 0.35 (via fruit) + 200 (via arthropods) = 200.4 ng HBCD/d	Deer Mouse 0.008 mg/kg BW-d
Deer mouse % diet of fruit in summer	25%	Wolff et al., 1985 ¹		
Deer mouse body weight (female)	24.5 g	Millar and Innes, 1983 ¹		
HBCD in fruits (biomonitoring data: food basket study in South Korea)	0.127 μg HBCD/kg ww	Barghi (2016)		
HBCD in grasshopper (biomonitoring data: near electronic-waste dismantling facilities in China)	32.4 ng HBCD/g bw	Zhu (2017)		
Deer mouse % diet of arthropods in summer	56%	Wolff et al., 1985 ¹		
American kestrel ingestion rate (vertebrates-winter)	0.18 g/g bw-d	Koplin et al., 1980 ¹	American kestrel 64.4 ng HBCD/d (via Deer mouse)	American kestrel 0.0005 mg/kg BW-d (via Deer mouse)
American kestrel % diet of mammals	31.7%	Meyer and Balgooyen, 1987 ¹		

Organism's Attribute	Assumption	Reference	Amount of HBCD Consumed per Day	Amount of HBCD Consumed per day Normalized to Body Weight
American kestrel body weight (female-winter)	138 g	Gessaman and Haggas, 1987 ¹		
Mink ingestion rate	0.16 g/g bw-d	Bleavins & Aulerich, 1981 ¹	Mink 700.7 ng HBCD/d (via trout)	Mink 0.0004 mg/kg BW-d (via trout)
Mink weight	1,734 g	Hornshaw et al., 1983 ¹		
Mink % diet of trout	56%	Alexander, 1977 ¹		
HBCD in trout	4.51 ng HBCD/g	Tomy (2004)		
Osprey body weight (female)	1,725 g	Pool, 1984 ¹	Osprey diet ² : 2 - 3,370,200 ng HBCD/d (listed below)	Osprey diet ² : 1x10 ⁻⁶ - 2 mg/kg BW-d (listed below)
Osprey % diet of fish	100%	Brown and Amadon, 1968 ¹ ; Poole, 1989 ¹		
HBCD in Rainbow trout	4.51 ng HBCD/g	(Tomy et al. 2004)	1,479 ng HBCD/d	0.001 mg/kg BW-d
HBCD in Northern Snakehead (biomonitoring data: food basket study in South China)	6.1 pg/g	(Meng et al. 2012)	2 ng HBCD/d	1x10 ⁻⁶ mg/kg BW-d
HBCD in Brown trout (biomonitoring data: downstream of HBCD manufacturing plant in the UK)	6,758 ng HBCD/g	(Allchin and Morris 2003)	2,216,624 ng HBCD/d	1.3 mg/kg BW-d
HBCD in Eel (biomonitoring data: downstream of HBCD manufacturing plant in the UK)	10,275 ng HBCD/g	(Allchin and Morris 2003)	3,370,200 ng HBCD/d	2.0 mg/kg BW-d

¹Exposure factors, as indicated, were derived from the U.S. EPA Wildlife Exposure Factors Handbook. ([U.S. EPA 1993b](#))

²HBCD tissue concentrations for osprey diet as categorized in the U.S. EPA Wildlife Exposure Factors Handbook. ([U.S. EPA 1993b](#)) were not available for those listed species, however a range of higher trophic level fish species were used to provide a range of potential HBCD uptake via osprey prey ingestion.

Table 3-3. Potential Trophic Transfer of HBCD in Aquatic and Terrestrial Ecosystems using the ECHA Guidance on Information Requirements and Chemical Safety Assessment (Environmental Exposure Assessment)

Organism's Attribute	Assumption	Reference	HBCD in Organism
Rainbow trout (whole body BCF)	8,974	Drottar and Kruger (2000)	HBCD Rainbow trout concentration (C_{fish}) = 16.2 mg/kg BW
HBCD exposure concentration to Rainbow trout	1.8 μ g/L	Drottar and Kruger (2000)	
Rainbow trout whole body lipid percentage	0.083	Drottar and Kruger (2000)	Lipid normalized HBCD Rainbow trout concentration (C_{fish}) = 60.1 mg/kg
Rainbow trout (whole body lipid normalized BCF)	108,120.5	Drottar and Kruger (2000)	
Earthworm bioconcentration factor (BCF)	4.5	Auferheide (2003)	Earthworm concentration ($C_{earthworm}$) = 18,855 mg/kg
HBCD exposure concentration to earthworm	4,190 mg/kg dry soil	Auferheide (2003)	

As presented in Table 3-2, it is likely for HBCD to undergo trophic transfer in both aquatic and terrestrial ecosystems, however it is evident that aquatic organisms or predators of aquatic organisms are more likely to be exposed to HBCD. In regards to the estimation of American kestrel dietary exposure to HBCD, it is likely the results as presented in Table 3-2 underestimate American kestrel exposure to HBCD because the primary source of HBCD is coming from the measurement of HBCD from one type of fruit (watermelon), and grasshoppers; data limitations regarding the availability of more exposure factors include characterizing the dietary composition of rodents and American kestrels, and measured HBCD uptake and body burden data for prey organisms. In comparison to mink and osprey, where 100% of their diet can be attributed to higher trophic level fish and a greater availability of HBCD uptake and body burden data for fish, estimations for American kestrel uptake of HBCD through prey consumption is limited to less than a third of American kestrel diet (small mammal), as characterized by the U.S. EPA Wildlife Exposure Factors Handbook. (U.S. EPA, 1993b). Furthermore, approximately 20% of rodent uptake of HBCD is not encompassed in the presented estimations. Similarly, mink dietary exposure to HBCD is also being underestimated because the above calculations only encompass approximately 56% of mink diet; a majority of mink diet consists of upper trophic level fish, and it is likely that mink are exposed to more than 700 ng HBCD/d if other higher trophic level fish were used for the remaining half of mink diet.

EPA did not identify toxicity data for mink or any other higher trophic level terrestrial predator (other than American kestrel) due to HBCD exposure, thereby making it difficult to determine a hazard threshold for this terrestrial mammal. Osprey exposure to HBCD via estimations of higher trophic level fish consumption is comparable to that estimated for mink, assuming 100% trout or higher trophic level fish consumption. An allometrically-scaled Osprey LOEC of 40.8 ng/g BW-d (Fernie et al. 2011), or the consumption of 70,380 ng HBCD/d (calculations in Appendix H.2), was significantly surpassed by 3 magnitudes when it was assumed that osprey consumed brown trout or eel (Allchin and Morris 2003), which may result in reproductive toxicity (smaller clutches); should the reproductive toxicity estimate for osprey apply, it is likely that their consumption of higher trophic level pelagic or benthic fish will result in reproductive toxicity and population-level effects. As discussed above, from the presented estimations, even if the entire American kestrel diet consisted of small mammal consumption, it is unlikely that American kestrel would be exposed to HBCD concentrations that will result in

reproductive toxicity. Uncertainties due to the use of a representative species for a predator are outlined below in Section 3.1.7, however, doing the same for prey species may also under- or overestimate HBCD dietary exposure. Less than 50% of the diets of Deer mouse and American kestrel are being accounted for and the lipid contents of the fruit (watermelon) and arthropods (grasshopper) used to estimate the original dietary HBCD exposure of Deer mouse are lower than that of the higher trophic level fish used to estimate osprey or mink dietary uptake. Data gaps make it difficult to ascertain whether terrestrial predatory organisms such as American kestrel may be exposed to higher HBCD concentrations through trophic transfer processes.

The estimated HBCD tissue concentrations and bioaccumulation of organisms in multiple trophic levels (categorized by KABAM in Appendix G Sections G.3.1 and G.3.2) are based on either the 10th or 50th percentile predictions for surface and pore water HBCD concentrations associated with exposure scenario-related releases (3.3 and 5.7). In regard to the measured HBCD tissue concentration predictions for higher trophic level fish (Table 3-2), these values are more comparable to the KABAM predictions based on the 50th percentile surface and pore water concentrations. The higher concentrations of HBCD in fish tissues represent sampling areas downstream of a manufacturing facility and are better represented by the predicted KABAM values for fish tissue concentrations than the fish sampled in areas not associated with industrial facilities. Although the 10th percentile KABAM predictions are all greater than the measured fish tissue concentrations, the measured tissue concentrations are only an indication of a background tissue concentration, and it is likely that releases from an industrial facility or use will result in higher HBCD exposure and bioaccumulation. The predicted BAFs, are within the same magnitude as measured BAFs (both lipid normalized) for upper trophic level fish ([He et al. 2013](#); [Wu et al., 2011](#)).

3.1.4 Weight of the Scientific Evidence

During data integration stage of systematic review, EPA analyzed, synthesized, and integrated the environmental information for HBCD. This involved weighing scientific evidence for quality and relevance, using a Weight of the Scientific Evidence (WOE) approach ([U.S. EPA 2018b](#)).

During data evaluation of the relevant HBCD studies, a rating of high, medium, or low for quality based on the TSCA criteria described in the [Application of Systematic Review in TSCA Risk Evaluations](#) was applied ([U.S. EPA 2018b](#)). While integrating environmental hazard data for HBCD, EPA gave more weight and consideration to relevant data/information rated high or medium for quality. Only data/information rated as high, medium, or low for quality was used for the environmental risk assessment. Any information rated as unacceptable was not used to characterize the hazard of HBCD. The factors for determining if environmental data/information were relevant, were based on whether the source had biological, physical/chemical, and environmental relevance ([U.S. EPA 1998](#)):

- a. **Biological relevance** – correspondence among the taxa, life stages, and processes measured or observed and the assessment endpoint.
- b. **Physical/chemical relevance** – correspondence between the chemical or physical agent tested and the chemical or physical agent constituting the stressor of concern.
- c. **Environmental relevance** – correspondence between test conditions and conditions in the region of concern. ([U.S. EPA 1998](#))

This WOE approach was used to assess the environmental hazard data of HBCD and develop concentrations of concern (COCs) for the aquatic compartments (i.e., surface water, sediment) and

environmental concern levels for the terrestrial environment. Where high or medium quality studies were available for a taxonomic group, low quality studies were not used to derive COCs or environmental concern levels.

To assess aquatic toxicity from acute exposures, data for three taxonomic groups were available: algae, aquatic invertebrates (*i.e.*, surface water and sediment dwelling) and fish. For each taxonomic group, data were available for these species as shown in Table 3-1. To characterize fish toxicity resulting from acute exposures to HBCD, a 96-hour zebrafish (*D. rerio*) LOAEL of 0.002 mg/L based on delayed embryo hatchability was used.

To assess aquatic toxicity from chronic exposures, data for two taxonomic groups were described in the acceptable literature: fish, and two species for aquatic invertebrates (*i.e.*, the water flea (*D. magna*), the black worm (*L. variegatus*)). Therefore, the endpoints for fish and aquatic invertebrates including surface water and sediment-dwelling organisms (MATC, NOEC, and an LOEC) were more biologically relevant, because they measured a toxic effect. Of these values, the most sensitive species were a 21-day MATC of 0.042 mg/L measuring reproduction in aquatic invertebrates (*D. magna*) and a 28-day MATC of 15.7 mg/kg dw measuring worm survival in *L. variegatus*.

To assess the toxicity of HBCD to algae, data on four acceptable high-quality studies reported data on three species of freshwater and marine vegetation (*i.e.*, green algae and diatoms). The most sensitive endpoint reported for marine diatom (*Skeletonema costatum*) was a 72-hour EC₅₀ of 0.010 mg/L from Walsh et al. (1987). As previously stated, algae data were assessed together with acute and chronic endpoints regardless of duration and not separated into acute and chronic, because durations normally considered acute for other species (*e.g.*, 48, 72 hours) can encompass several generations of algae. A NOEC of 10 µg/L was reported by Desjardins et al. (2004) for the same species. This study provides support for the high toxicity of HBCD to algae that was reported in Walsh et al. (1987) by measuring the exposure concentrations.

To assess terrestrial toxicity from chronic exposures, data for three taxonomic groups were described in the acceptable literature: terrestrial plants, soil invertebrates and avian species. Therefore, the endpoints for terrestrial plants, soil invertebrates and avian species (EC₅₀, MATC, LOEC, NOEC, NOAEL, LOAEL and LOEC) were more biologically relevant, because they measured a toxic effect. Of these values, the most sensitive species were a 4-day maize (*Zea mays*) measuring growth reduction and reporting a LOAEL of 0.002 mg/L, a 14-day earthworm (*Eisenia fetida*) reporting a MATC of 200 mg/kg/day measuring reproduction effects and a 21-day LOAEL in American kestrel (*F. sparverius*) measuring reproduction reporting a LOAEL of 3.27 ng/g ww.

3.1.5 Concentrations of Concern

The concentrations of concern (COCs) for aquatic species were calculated based on the environmental hazard data for HBCD, using the weight of evidence approach described above and EPA methods (Suter 2016; U.S. EPA 2013c, 2012c). For HBCD, EPA derived an acute COC, a chronic COC, and an algal COC. Algae was assessed separately and not incorporated into acute or chronic COCs, because durations normally considered acute for other species (*e.g.*, up to 96 hours) can encompass several generations of algae.

After weighing the evidence and selecting the appropriate toxicity values from the integrated data to calculate an acute and chronic COC, an assessment factor (AF) is applied according to EPA methods (Suter 2016; U.S. EPA 2013c, 2012c). The application of AFs provides a lower bound effect level that would likely encompass more sensitive species not specifically represented by the available

experimental data. AFs also account for differences in inter- and intra-species variability, as well as laboratory-to-field variability. These AFs are dependent on the availability of datasets that can be used to characterize relative sensitivities across multiple species within a given taxa or species group. However, they are often standardized in risk assessments conducted under TSCA, since the data available for most industrial chemicals are limited. For fish and aquatic invertebrates (*e.g.*, daphnia) the acute COC values are typically divided by an AF of 5. The acute toxicity value is derived from an embryo toxicity endpoint, and the AF used to derive the hazard threshold for acute exposure is 5. For chronic COCs, an AF of 10 is used ([U.S. EPA 2013c](#), [2012c](#)). Environmental concentration levels were derived for terrestrial organisms. An AF of 10 was also used to derive a COC for algae because the effects measured (reproduction and growth) are generally considered to be associated with a longer time frame or chronic exposure for this taxa.

Table 3-4. Concentrations of Concern (COCs) for Aquatic Toxicity

Environmental Toxicity	Effects	Hazard Value	Assessment Factor	Concentration of Concern (COC)	Reference	Score
<i>Acute toxicity</i>						
Zebrafish (<i>D. rerio</i>) 96-hr LOAEL	Delay Hatching	2 µg/L	5	0.4 µg/L	(Hu et al., 2009a)	High
<i>Chronic toxicity</i>						
Water flea (<i>D. magna</i>) 21-d MATC (surface water)	Reduced length of surviving young	4.2 µg/L	10	0.417 µg/L	(Drottar and Krueger 1998)	High
California blackworm (<i>L. variegatus</i>) 28-day MATC (sediment)	Reduction in worm number	15,700 µg/kg dw	10	1,570 µg/kg/dw	(Oetken et al. 2001)	High
<i>Algae</i>						
Marine diatom (<i>S. costatum</i>) 72-hr EC₅₀	Growth Rate	10 µg/L	10	1 µg/L	(Walsh et al. 1987)	High

To calculate the acute COC of 0.4 µg/L, the acute value from the zebrafish (*D. rerio*) 96-hour LOAEL of 2 µg/L was divided by an AF of 5.

In regards to calculating a chronic COC, the aquatic invertebrate (*D. magna*) 21-day MATC chronic value of 4.2 µg/L was divided by an AF of 10, per established EPA methods ([U.S. EPA 2013c](#), [2012c](#)), resulting in a chronic COC of 0.4 µg/L. Similarly, the algae 72-hr EC₅₀ of 10 µg/L was divided by an AF of 10, resulting in a COC of 1 µg/L.

A chronic COC of 1,570 µg/kg dw, based on the benthic organism, *L. variegates*, was derived from the 28-day MATC of 15,700 µg/kg dw, which was divided by an AF of 10, per established EPA methods ([U.S. EPA 2013c](#), [2012c](#)).

Table 3-5. Terrestrial Effect Concentrations (Hazard) used to Evaluate Toxicity to Terrestrial Organisms

Environmental Toxicity	Effects	Hazard Value	Reference	Score
Maize	Growth (root and shoot)	2 µg/L	(Wu et al. 2016c)	High

4-d LOAEL				
Earthworm 56-day MATC	Reproduction/ Mortality	173,000 µg/kg dwt	(Aufderheide et al. 2003)	High
American kestrel 21-d LOAEL	Reproduction (clutch size, egg production timing)	0.51 mg/kg bw	(Ferne et al., 2011)	High
Rat 2-generation NOAEL	Thyroid hormones response, Reproduction	10 mg/kg bw	(Ema et al., 2008)	High

Studies where terrestrial organisms were exposed to HBCD were evaluated and those with high data evaluation scores (using either environmental hazard Systematic Review metrics) and relevant environmental exposure pathways were used to assess risk to terrestrial organisms. The organisms identified in the abovementioned studies in Table 3-5 were chosen to represent their respective taxa classifications (*i.e.*, vegetation, invertebrate, vertebrate). To evaluate HBCD hazard thresholds for terrestrial wildlife, environmental hazard levels were used as reported by study authors because there was not enough information available to derive assessment factors.

3.1.6 Summary of Environmental Hazard

HBCD presents a significant concern for adverse effects on the environment. This conclusion is based on the observed potential for bioaccumulation, trophic transfer, altered reproductive behavior, as well as toxicity due to both acute and chronic HBCD exposure. Bioconcentration factors (BCFs) and biomagnification factors (BMFs) as high as 18,100 and 29.7, respectively, have been observed in fish ([Zhang et al. 2014b](#); [Du et al. 2012a](#); [Law et al. 2006](#)). BMF values of 26 (lipid-weight) and 1.6 - 3 have also been observed in birds ([Haukås et al. 2010b](#)) and mammals ([Shaw et al. 2012](#)) respectively. Observed toxicity values as low as 0.009 mg/L for a 72-hour EC₅₀ (reduced growth in the marine diatom, *S. costatum*) ([Walsh et al. 1987](#)), and 0.0042 mg/L (MATC for reduced size (length) of surviving young in *D. magna*) ([Drott and Krueger 1998](#)), indicate high aquatic toxicity due to acute and chronic HBCD exposure.

Reduced chick survival in Japanese quail (*C. japonica*) fed a 15 ppm HBCD diet (2.1 mg/kg bw-day) ([MOEJ 2009](#)) and altered reproductive behavior (reduced courtship and brood-rearing activity) and reduced egg size in American kestrels (*F. sparverius*) fed 0.51 mg/kg bw-day ([Marteinson et al. 2012](#); [Ferne et al. 2011](#); [Marteinson et al. 2011](#); [Marteinson et al. 2010](#)) indicate high toxicity for terrestrial organisms as well.

Assessment of HBCD aquatic toxicity is complicated by the low water solubility of the chemical and differences in the solubility of the three main HBCD isomers, which makes testing difficult and interpretation uncertain for studies conducted above the water solubility. Studies conducted at concentrations above the water solubility of HBCD are essentially testing the effects at the maximum HBCD concentration possible. In contrast with the studies cited above, other acute and chronic aquatic toxicity studies conducted using methods, test species, and endpoints recommended by the EPA reported no effects at saturation or near the limit of water solubility. However, water solubility is not considered a limiting factor for hazard determination for aquatic species since there are studies showing adverse effects at or below the water solubility of HBCD. In addition, the potential for HBCD to bioaccumulate, bio-magnify, and persist in the environment, significantly increases concerns regarding HBCD exposure for aquatic organisms.

A wide range of effects of HBCD have been reported in fish (*e.g.*, developmental toxicity, embryo malformations, reduced hatching success, reduced growth, hepatic enzyme and biomarker effects, thyroid effects, DNA damage to erythrocytes, and oxidative damage) and invertebrates (*e.g.*, degenerative changes, morphological abnormalities, decreased hatching success, and altered enzyme activity) in supporting studies that assessed endpoints beyond those evaluated in this assessment ([Du et al. 2015](#); [Hong et al. 2015](#); [Foekema et al. 2014](#); [Hong et al. 2014](#); [Zhang et al. 2014a](#); [Wu et al. 2013](#); [Du et al. 2012a](#); [Anselmo et al. 2011](#); [Palace et al. 2010](#); [Deng et al. 2009](#); [Hu et al. 2009a](#); [Smolarz and Berger 2009](#); [Aniagu et al. 2008](#); [Palace et al. 2008](#); [Zhang et al. 2008](#); [Ronisz et al. 2004](#)). Effects on the thyroid in fish (reduced thyroid hormone (triiodothyronine, T3, and thyroxine, T4) in rainbow trout ([Palace et al. 2010](#); [Palace et al. 2008](#); [Kuiper et al. 2007](#); [Lower and Moore 2007](#)) are similar to those observed in mammals. These studies were also evaluated using metrics and the rating criteria described in the Application of Systematic Review in TSCA Risk Evaluations document ([U.S. EPA 2018b](#)).

COCs derived for aquatic organisms are summarized in Table 3-2. EPA calculated the chronic COC for HBCD based on two high quality studies at 4.2 ppb and 157 µg/kg dw, based on an MATC for *D. magna* and *L. variegatus*, respectively.

Also, the terrestrial effect concentrations derived for terrestrial organisms are summarized in Table 3-3. EPA calculated the environmental concern levels for terrestrial receptors for HBCD based on three acceptable studies at 2 µg/L and 173 µg/kg dw and 10 µg/kg bw based on a LOAEL for maize, a MATC for earthworms, and a NOAEL for rats, respectively.

As stated previously, algae were assessed separately from other aquatic organisms, because durations normally considered acute for other species (*e.g.*, 48, 72 hours) can encompass several generations of algae. EPA calculated an algal COC for HBCD at 1 µg/L, based on a geometric mean of a LOEC and NOEC for growth in the marine diatom (*S. costatum*) from Walsh et al. ([1987](#)), a study rated high for quality.

3.1.7 Assumptions and Key Sources of Uncertainty for the Environmental Hazard Assessment

After evaluating all available environmental hazard data on HBCD, EPA has high confidence in the environmental hazard data used to assess the environmental hazard of HBCD and high confidence that the data incorporates environmentally-protective acute and chronic concentrations of concern (as described above). Despite the high confidence in the data used to assess the environmental hazard of HBCD, there are sources of uncertainty regarding the extrapolation of available data and methods used to select a representative species and taxa that are addressed below.

In characterizing the environmental hazard of HBCD, some uncertainty in the analysis of environmental exposure is due to the inherent nature that the proportion of diastereomers in HBCD mixtures will differ based on commercial and consumer products used, and the changes of such proportions that may occur following environmental release. Similarly, the environmental hazard of HBCD will depend on the exposure to varying proportions and concentrations of HBCD diastereomers; most studies reported exposure and effects concentration in total HBCD, however studies that concentrated on bioisomerization generally parsed out exposure based on individual diastereomer. The sole use of HBCD diastereomer-specific partitioning and toxicity data may result in the underestimation of overall HBCD environmental hazard because diastereomer proportions will continue to change in the environment.

For evaluating the potential trophic transfer of HBCD in the environment, many assumptions and uncertainties were taken into consideration due to the complexity of food web dynamics. In general, there is an inherent uncertainty when using proxy organisms to represent all terrestrial and aquatic prey and predators; the selection was based on data availability, thus making it difficult to represent more than three levels of prey-predator relationships. Organism selection for this evaluation was exclusively from the available exposure factors in the *U.S. EPA Wildlife Exposure Factors Handbook* (also incorporated in the *U.S. EPA Final Water Quality Guidance for Great Lakes System*). Variations in diet categories due to life stage, gender, and seasonal differences are not addressed in this evaluation because the specificity and calculation of each exposure factor are based on the methodologies used in their respective original references cited by the *U.S. EPA Final Water Quality Guidance for Great Lakes System* and *U.S. EPA Wildlife Exposure Factors Handbook*. Further, the inability to account for complete diets and the potential variations in diet may have resulted in the under- or overestimation of HBCD uptake. Specifically, in regard to mink diet, HBCD uptake calculations using methodologies from the *U.S. EPA Final Water Quality Guidance for Great Lakes System* and *U.S. EPA Wildlife Exposure Factors Handbook*, and trout HBCD biomonitoring data could only account for 56% of mink diet; an additional 26% and 18% of their diet was labeled “non-trout” fish, and miscellaneous items, respectively. Like the other organisms used to calculate potential HBCD uptake via ingestion, large portions of mink diet are unaccounted for due to a lack of reasonably available information on either the diet composition, or HBCD body burden in prey organisms. Further underestimations of HBCD uptake by terrestrial predators, as compared to aquatic predators in this assessment (*i.e.*, calculated by evaluating Kestrel ingestion of mice) may also be due to the use of fruit and grasshopper HBCD biomonitoring data as the original source of HBCD for kestrel, as opposed to smaller mammals with a higher body fat composition. The limited data regarding HBCD in terrestrial organisms contributes to the uncertainty regarding HBCD trophic transfer in terrestrial food webs. Additionally, HBCD trophic transfer was not quantified or evaluated for every level of biological organization because biomonitoring data were available for many lower trophic level organisms. The uncertainties regarding the ingestion of HBCD also do not take into consideration physiological processes that impact the absorption, metabolism, distribution and elimination of HBCD, once ingested. The available literature regarding how HBCD is absorbed, metabolized, distributed and eliminated are largely evaluations of the bioisomerization of HBCD once ingested.

HBCD has physical-chemical properties that are within the model domains of KABAM (v1), which allows for the prediction of potential trophic transfer of a chemical within a freshwater aquatic ecosystem. KABAM (v1) provides an opportunity to model potential HBCD bioaccumulation, bioconcentration, and trophic transfer due to predicted releases for individual sub-scenarios within a specific COU (using PSC-VMWS), which thereby correspond with risk estimates calculated for pelagic and benthic organisms. However, there are limitations involved with the extrapolation of the model outputs, one of which being that the amount of HBCD predicted to undergo trophic transfer, is predicted for trophic levels and not specific species. Further, the default model ecosystem for KABAM is a freshwater pond that receives pesticides in both runoff and spray drift from an adjacent 10-ha treatment field; HBCD is not a pesticide, thus the introduction of HBCD to the model freshwater pond may not be representative of the exposure scenarios used to assess environmental risk.

The analysis focuses on HBCD uptake via prey ingestion as an indicator for potential HBCD trophic transfer in aquatic and terrestrial food webs, and does not take into consideration the uncertainties regarding the physiological processes that impact the absorption, metabolism, distribution and elimination of HBCD, once ingested. Specifically, the available literature primarily focuses on HBCD diastereomer-specific body burdens as a function of the potential bioisomerization of α -, β -, and γ -

HBCD. However, as there is no consensus on the uptake, biotransformation, and elimination of HBCD diastereomers once ingested, it is difficult to ascertain whether HBCD diastereomer-specific uptake and exposure is a function of environmental concentrations and/or bioisomerization of HBCD once ingested. Similar to polybrominated diphenyl ethers, where different congeners are found differentially in aquatic or terrestrial organisms, potentially resulting in different dietary exposures, there is also speculation on whether aquatic or terrestrial ecosystem conditions differentially result in diastereoisomer-specific isomerization and degradation of HBCD ([Potter et al. 2009](#)).

As mentioned in Appendix C.2, α -HBCD bioaccumulate and biomagnifies to a greater extent than either β - and γ - diastereomers in aquatic food webs, despite γ -HBCD being the isomer primarily found in commercial mixtures. Furthermore, the bioisomerization of γ -HBCD to α -HBCD in fish ([Du et al., 2012a](#)) and the higher water solubility of α -HBCD (as compared to the other diastereomers) suggest that regardless of the percentages of diastereomers in commercial mixtures, once released into the environment, there is a higher likelihood of organisms being exposed to α -HBCD. Diastereomer-specific excretion will also influence whether higher trophic level predators will be exposed to HBCD via prey ingestion. In rats that were orally exposed to all three HBCD diastereomers, HBCD diastereomer excretion through both feces and urine was greater for β - and γ - diastereomers, than α -HBCD ([Hakk 2016](#)). Species-specific differences in physiological processes will also greatly impact predator-specific uptake of HBCD. Prey habitat and diet (*e.g.*, types of organic matter) may also impact gut microbiome composition and physiological ability to ingest, metabolize and store bioaccumulative chemicals, such as HBCD. Due to the higher lipid and protein found in the earthworm, *E. fetida*, as compared to *M. guillelmi*, as well as differences in HBCD uptake, depuration, metabolism and isomerization, the biota soil accumulation factor for HBCD was higher in *E. fetida*. Furthermore, the bioisomerization of β - and γ -HBCD to α -HBCD was observed to a greater extent in *E. fetida* than in *M. guillelmi*. In addition to having a longer half-life than β - and γ -HBCD, α -HBCD also bioaccumulated to a greater extent than the other two diastereomers in earthworms exposed to soil samples individually containing HBCD diastereomers ([Li et al. 2016](#)). In general, evaluating the trophic transfer of HBCD using any method will not be able to account for all sources of physiological differences (*i.e.*, age, gender, and seasonal impacts on prey availability) that will ultimately affect HBCD exposure and bioavailability.

Finally, the AFs used to derive concentrations of concern do not take into account organisms being exposed to HBCD via multiple pathways (*i.e.*, media, dietary), or the other uncertainties discussed above. Unfortunately, there is insufficient information available on the impact of organism sensitivity resulting from either different or simultaneous exposure pathways to HBCD.

3.2 Human Health Hazards

3.2.1 Approach and Methodology

EPA used the approach described in Section 1.5 to evaluate, extract and integrate HBCD's human health hazard and dose-response information.

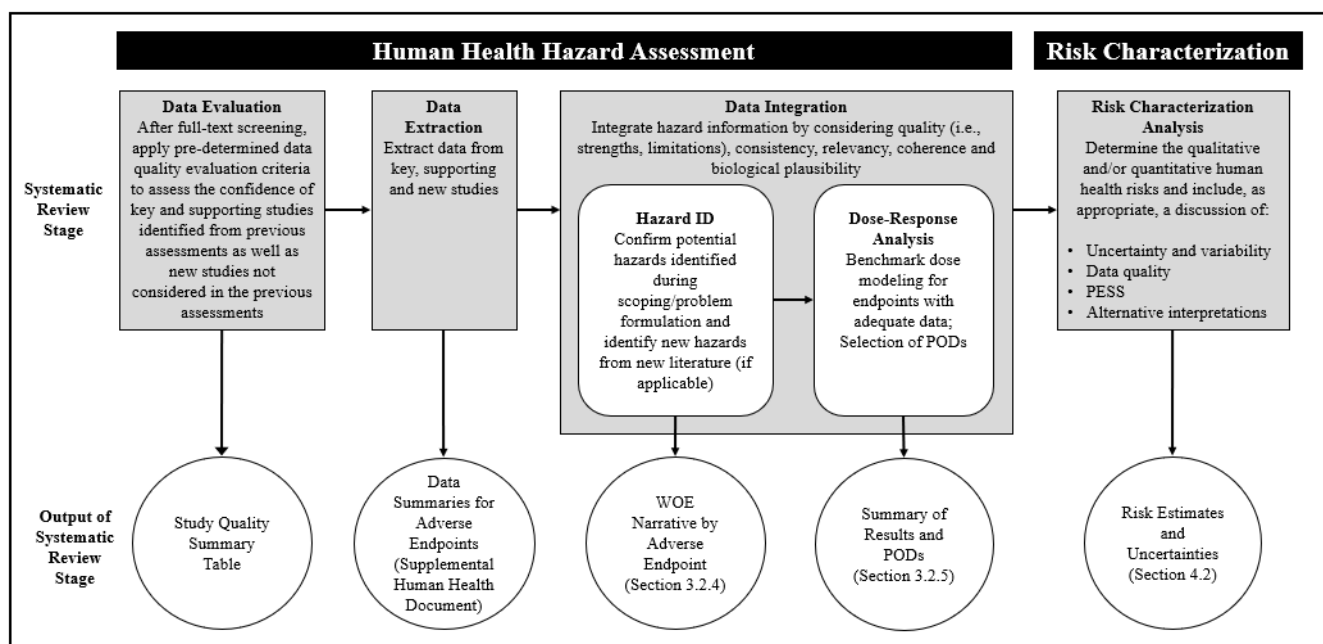

Figure 3-1. EPA Approach to Hazard Identification, Data Integration, and Dose-Response Analysis for HBCD

Specifically, EPA reviewed key and supporting information from previous hazard assessments as well as the existing body of knowledge on HBCD's human health hazards. These data sources¹⁷ included the TRI Technical Review of HBCD ([U.S. EPA, 2016e](#)), the TSCA Work Plan Problem Formulation and Initial Assessment, ([U.S. EPA 2015a](#)), Preliminary Materials for the IRIS Toxicological Review of HBCD ([U.S. EPA 2014f](#)) as well as other publications ([U.S. EPA 2016e, 2014d](#); [NICNAS 2012a](#); [EC/HC 2011](#); [EINECS 2008](#); [U.S. EPA 2008a](#); [OECD 2007](#)). Additional scientific support from the Office of Research and Development subsequent to these publications also contributed to this human health hazard assessment.

All non-cancer health hazards of HBCD previously identified in these reviews were described and reviewed in this Risk Evaluation, including: acute toxicity, liver toxicity, thyroid effects, reproductive/developmental toxicity, neurotoxicity, immunotoxicity, sensitization and irritation. EPA relied heavily on the aforementioned existing reviews along with scientific support from the Office of Research and Development in preparing this Risk Evaluation. Development of the HBCD hazard and dose-response assessments considered EPA and National Research Council (NRC) risk assessment guidance.

The new literature was screened against inclusion criteria in the PECO statement and the relevant studies (*e.g.*, useful for dose-response)¹⁸ were further evaluated using the data quality criteria for human, animal, and *in vitro* studies described in the *Application of Systematic Review in TSCA Risk Evaluations* ([U.S. EPA 2018b](#)) (see Section 1.5). EPA skipped the PECO screening step of the key and supporting studies and entered them directly into the data quality evaluation step based on their previously identified relevance to the Risk Evaluation.

¹⁷ HBCD does not have an existing EPA IRIS Assessment.

¹⁸ Some of the studies that were excluded based on the PECO statement were considered later during the systematic review process as needed. For example, EPA reviewed mode of action information to qualitatively support the health hazard assessment.

EPA considered studies of low, medium, or high confidence for hazard identification and dose-response analysis. Information from studies that were rated unacceptable were only discussed on a case-by-case basis for hazard ID and weight-of-evidence assessment but were not considered for dose-response analysis. EPA considered the specific reasons for the unacceptable scoring in determining whether unacceptable studies could remain useful for hazard ID or weight-of-evidence.

EPA has not developed data quality criteria for all types of hazard information. This is the case for toxicokinetics and many types of mechanistic data which EPA typically uses for qualitative support when synthesizing evidence. As appropriate, EPA evaluated and summarized these data to determine their utility for supporting the Risk Evaluation (*e.g.*, ADME data).

Following the data quality evaluation, EPA integrated the toxicological information from each relevant study. In the last step, the strengths and limitations of the data were evaluated for each endpoint and a weight-of-the-scientific evidence narrative was developed. Data for each selected hazard endpoint was modeled to determine the dose-response relationship (Appendix I). Finally, the results were summarized, and the uncertainties were presented. The process is described in Figure 3-1.

The weight of scientific evidence (WOE) analysis included integrating information from toxicokinetics and toxicodynamics in relation to the key hazard endpoints: acute toxicity, liver toxicity, thyroid effects, reproductive/ developmental toxicity, neurotoxicity, immunotoxicity, sensitization and irritation. EPA considered both data quality and relevance in selecting human health studies to move forward for dose-response analysis in order to quantitatively assess each key hazard endpoint. EPA also considered supportive data on mode of action (MOA) for these endpoints in evaluating the WOE for each endpoints.

Dose-response analyses using benchmark dose modeling (BMD) was performed for each hazard endpoint of concern where possible. In an effort to address some of the limitations of the NOAEL/LOAEL approach, the BMD approach was developed as a more robust alternative that considers all the data in the dose-response relationship ([U.S. EPA 2012a](#)). A summary table which includes all endpoints considered for this assessment, the no-observed- or lowest-observed-adverse-effect levels (NOAEL and LOAEL) for non-cancer health endpoints by target organ/system, the incidence for cancer endpoints, and the results of the data quality evaluation is provided in *Risk Evaluation for Cyclic Aliphatic Bromide Cluster (HBCD), Systematic Review Supplemental File: Data Quality Evaluation of Human Health Hazard Studies*. ([U.S. EPA 2019n](#)).

EPA considered points of departure (POD) from studies that were PECO relevant, scored acceptable in the data quality evaluation, and contained adequate dose-response information. It is used as the starting point for subsequent dose-response (or concentration-response) extrapolations and analyses. PODs can be a no-observed-adverse-effect level (NOAEL), a lowest-observed-adverse-effect level (LOAEL) for an observed incidence, or change in level of response, or the 95% lower confidence limit of the benchmark dose (BMDL)¹⁹. PODs were adjusted as appropriate to conform to the specific exposure scenarios evaluated.

The only available repeat-dose toxicity studies available on HBCD were conducted via the oral route of exposure (except for a single 14-day inhalation study ([Song et al. 2016](#))). These studies were evaluated

¹⁹ The benchmark dose (BMD) is a dose or concentration that produces a predetermined change in response range or rate of an adverse effect (called the benchmark response or BMR) compared to baseline.

for dose-response assessment, and oral PODs were extrapolated for use via the inhalation route because it is assumed that inhaled HBCD will be absorbed either through the lungs or via the GI tract following incidental ingestion. Limited toxicological data are available by the dermal route and physiologically based pharmacokinetic/ pharmacodynamic (PBPK/PD) models that would facilitate route-to-route extrapolation have not been identified for HBCD. Therefore, oral PODs were also extrapolated for use via the dermal route, with adjustments made for absorption. The PODs estimated based on effects in adult animals were converted to Human Equivalent Doses (HEDs) employing a standard dosimetric adjustment factor (DAF) consistent with EPA guidance ([U.S. EPA 2011c](#)).

Section 3.2.5 describes the dose-response assessment guiding the selection of PODs for non-cancer endpoints. The benchmark dose analysis is discussed in Appendix I, and the *Risk Evaluation for Cyclic Aliphatic Bromide Cluster (HBCD), Supplemental Information on Human Health Hazard*. ([U.S. EPA 2019e](#)).

3.2.2 Toxicokinetics

3.2.2.1 ADME

3.2.2.1.1 Absorption

Absorption in the human gastrointestinal (GI) tract is expected given the detection of hexabromocyclododecane (HBCD) in samples of human milk, maternal blood/cord blood, or fetal tissue, and in food samples collected in several regions of the world ([Rawn et al. 2014b](#); [Rawn et al. 2014a](#); [NICNAS 2012a](#); [EC/HC 2011](#)).

HBCD isomers were rapidly and extensively absorbed in the GI tracts of mice given single oral doses of γ -[14C]-HBCD ([Szabo et al. 2010](#)), α [14C] HBCD ([Szabo et al. 2011a](#)), or β -HBCD ([Sanders et al. 2013](#)) and rats given single oral doses of [14C]- γ -HBCD (mixed with technical-grade HBCD containing ~75% γ -HBCD) ([Yu and Atallah 1980](#)). For example, the rat study indicated nearly complete absorption; after 72 hours, 72% of the administered radioactivity was detected in feces (as nonidentified metabolites), 16% in urine, and 17% in tissues excluding the GI tract ([Yu and Atallah 1980](#)). In studies of mice, absorption percentages between 85 and 90% were reported, based on tissue levels and cumulative fecal and urinary excretion of radioactivity ([Sanders et al. 2013](#); [Szabo et al. 2011a, 2010](#)).

The dermal absorption of HBCD has also been investigated in a few studies. Various *ex vivo* and *in vitro* skin models demonstrate that ~30-50% of dermally exposed HBCD will partition into skin tissue ([Pawar et al. 2016](#); [Abdallah et al. 2015](#)). The absorption of HBCD is influenced by both the composition of skin and the relative isomeric mixture of HBCD. HBCD is preferentially absorbed into sebum compared to sweat, and absorption increases from γ -HBCD < β -HBCD < α -HBCD. Substantially less HBCD penetrates through skin for systemic absorption. One study ([Roper et al. 2007](#)) estimated less than 0.1% systemic absorption of HBCD dissolved in acetone, with 35% delivered into the skin and only 1.35% remaining in the skin following washing and drying. Data from skin models suggests that 4.95 – 6.46% of α -HBCD dissolved in acetone is absorbed, with other isomers permeating even less ([Abdallah et al. 2015](#)).

For the purposes of this risk evaluation, an upper-end estimate of 100% gastrointestinal absorption will be used. It is assumed that any inhaled HBCD particles will be either absorbed through the lungs or swallowed and absorbed through the GI tract, although GI absorption is expected to predominate because the majority of particles are likely too large to reach the deep lung (further explained in Section 4.2.1). Based on available *ex vivo* and *in vitro* data, the highest-end estimate of 6.5% dermal absorption

of HBCD is used as a conservative health-protective assumption. Comparison of this upper end estimate for fraction absorbed with a calculation for flux/permeability produces very similar results (see Appendix L for full discussion), justifying use of the fraction absorbed method for risk estimation. The actual percentage of HBCD absorbed dermally is variable based on multiple factors including the relative percentage of each isomer in the mixture, particle size, the bioavailability of HBCD when entrained within foam or other particles, the presence of any potential organic solvent or non-aqueous media for HBCD particles, and the relative ratio of sweat to sebum on skin.

3.2.2.1.2 Distribution

Numerous studies of HBCD concentrations in samples of human milk, blood, fatty tissues, or fetal tissues have noted that α -HBCD is the predominant isomer detected, even though γ -HBCD is the predominant isomer in commercial HBCD products ([Rawn et al. 2014b](#); [Rawn et al. 2014a](#); [NICNAS 2012a](#); [EC/HC 2011](#)). These results indicate preferential tissue accumulation (especially in fat) of α -HBCD, compared with γ -HBCD or β -HBCD. In these studies, measurements of HBCD in maternal serum and umbilical cord serum of pregnant women have demonstrated that HBCD can cross the placenta and enter the fetal circulatory system.

In rats and mice, radioactivity from oral or intravenous (i.v.) administered [^{14}C]-HBCD distributes widely in the body, with the highest levels in fat, liver, skeletal muscle, and skin ([Sanders et al. 2013](#); [Szabo et al. 2011b](#); [Szabo et al. 2010](#); [Yu and Atallah 1980](#)). For example, 8 hours after administration of a single oral dose of [^{14}C]- γ -HBCD (mixed with technical-grade HBCD) in female rats, radioactivity was detected in the fat (20% of administered dose), muscle (14%), and liver (7%) with smaller amounts (<1%) in the blood, heart, lung, gonads, uterus, spleen, kidney, and brain ([Yu and Atallah 1980](#)). A similar relative distribution pattern was observed in male rats, except that the levels of radioactivity (expressed as a percentage of administered dose) in fat and muscle of males were lower (about one-half to three-quarters of the levels in females). Radioactivity in most tissues decreased over the course of 72 hours, but remained elevated in the fat. Nonpolar metabolites of HBCD accounted for all of the radioactivity in fat; isomeric composition in the fat was not determined.

The three HBCD isomers exhibit differential accumulation in mice exposed by gavage ([Sanders et al. 2013](#); [Szabo et al. 2011b](#); [Szabo et al. 2010](#)). At 1–3 hours after single radiolabeled doses of 3 mg/kg of each isomer were given, concentrations of HBCD-derived radioactivity were highest in the liver, followed by the adrenals, kidneys, and bladder (after exposure to γ -HBCD); fat, kidneys, and lung (after exposure to β -HBCD); or blood, kidney, and brain (after exposure to α HBCD). Tissue concentrations were markedly higher after exposure to α -HBCD (e.g., peak of 47,628 ng/g liver) than after exposure to the other isomers (peaks of 4,462 ng/g liver for β -HBCD and 2,309 ng/g liver for γ -HBCD). Tissue concentrations peaked 3–8 hours after exposure to either β or γ -HBCD, and declined steadily thereafter. In contrast, after exposure to α -HBCD, concentrations in the skin, muscle, and adipose tissue peaked 1–2 days later, indicating redistribution and accumulation of radioactivity in these tissues. Four days after exposure to each isomer, concentrations were markedly decreased in all tissues; at that time, the highest tissue concentrations were in the fat after exposure to β - and α HBCD (13,320 and 498 ng/g, respectively), and in the adrenal glands after exposure to γ -HBCD (492 ng/g) ([Sanders et al. 2013](#); [Szabo et al. 2011b](#); [Szabo et al. 2010](#)). The results indicate greater deposition of α -HBCD or its metabolites in most tissues, especially fat, compared with γ -HBCD and β -HBCD. Similar findings were reported by ([WIL Research 2001](#)) based on data from fat tissue samples collected from rats exposed to technical-grade HBCD for 90 days at a gavage dose of 1,000 mg/kg-day; β and γ -HBCD tissue concentrations were only 8–18% of the concentration of α -HBCD.

Sex-dependent differences in distribution were observed in rats exposed by gavage for 28 days to commercial HBCD at doses from 0.3 to 200 mg/kg-day ([van der Ven et al. 2006](#)). Concentrations of total HBCD were higher (on average 5-fold higher) in livers of female than male rats over the entire dose range. Fat tissue from female rats contained HBCD concentrations approximately 4.5-fold higher than those measured in male fat tissue (based on data from two rats/sex in the 10 mg/kg-day dose group). Findings from the 90-day rat study by ([WIL Research 2001](#)) showed a smaller sex-dependent difference in fat tissue concentrations. In rats exposed by gavage at a dose of 1,000 mg/kg-day, the mean α -HBCD concentrations in fat tissues was 40% greater in female rats than males at exposure day 89; the mean concentrations of β - and γ -HBCD in fat tissues in males and females were similar. Based on same collections on days 2, 6, 13, 20, 27, 55, 89, 104, and 118 of the study, the patterns of distribution into fat tissues in males and females were similar.

3.2.2.1.3 Metabolism

Studies in laboratory animals and in vitro studies show that HBCD isomers can undergo stereoisomerization, hydroxylation, and debromination, and that γ -HBCD and β -HBCD are more rapidly and extensively metabolized than α -HBCD. The results also indicate that cytochrome P450 (CYP450) enzymes are involved in metabolism of HBCD, but the predominant metabolic pathways and terminal excretory metabolites have not been fully characterized. Debrominated metabolites of HBCD have been detected in human breast milk samples, suggesting that debromination steps inferred from metabolites identified in laboratory animals are applicable to humans ([Abdallah and Harrad 2011](#)).

In vivo stereoisomerization of the γ - to the α -isomer has been demonstrated in toxicity studies of rats, and available data suggest that stereoisomerization is more important at higher doses. Dose-dependent stereoisomerization was observed in rats repeatedly exposed to commercial HBCD (with composition 10% α , 9% β , and 81% γ) by gavage ([van der Ven et al. 2006](#); [WIL Research 2001](#)) or dietary administration ([van der Ven et al. 2009](#)). In these studies, the ratios of the lipid-normalized concentrations of γ -isomer to the α -isomer (measured as parent compound using liquid chromatography/mass spectrometry [LC/MS]) in liver differed from the ratios in the administered material, and these ratios declined with increasing dose. For example, in adult rats exposed for 28 days ([van der Ven et al. 2006](#)), the ratios of the γ -isomer to the α -isomer (β -HBCD comprised <1.5% of the total HBCD in tissues) in females ranged from 4.2 at the low dose (0.3 mg/kg-day) to 0.4 at the high dose (200 mg/kg-day); in males, at the same doses, the ratios ranged from 2.3 at the low dose to 0.9 at the high dose. These values were all lower than the ratio of 8.1 in the administered material. This dose-dependent shift in the ratio of γ : α isomers was also observed in 11-week-old offspring of rats exposed before and during mating and during gestation and lactation ([van der Ven et al. 2009](#)).

Analysis of excreta and tissues following oral administration of [14 C]-HBCD to rats ([Yu and Atallah 1980](#)) showed extensive metabolism of γ -HBCD. None of the radioactivity recovered in urine or feces could be identified as parent γ -HBCD following oral administration of [14 C]- γ -HBCD (mixed with technical-grade HBCD containing ~75% γ -HBCD). Several polar metabolites of uncharacterized structure were found in extracts of feces and urine; these metabolites constituted 88% of the cumulative radioactivity excreted during the 72 hours after dosing ([Yu and Atallah 1980](#)).

Results of oral exposure studies in mice given the same dose of each isomer demonstrated more extensive metabolism of β - and γ -HBCD compared with α -HBCD ([Sanders et al. 2013](#); [Szabo et al. 2011a, 2010](#)). For example, more radioactivity was excreted in the urine after oral dosing with β -HBCD (~45% of administered dose over 4 days) than after the same dose of either α - or γ HBCD (~20–28% of administered dose). The urine contained only metabolites; none of the radioactivity in the urine was associated with the parent isomers ([Sanders et al. 2013](#); [Szabo et al. 2011a, 2010](#)). Extraction of feces

samples for thin layer chromatography analysis of radioactivity showed that a significant proportion of fecal radioactivity was not extractable after exposure to α -HBCD (64%) or γ -HBCD (52%), while a lower proportion was not extractable after exposure to β -HBCD (30%). ([Szabo et al. 2010](#)) hypothesized that nonextractable radioactivity in feces represented remnants from reactive metabolites covalently bound to proteins or lipids. Of the extractable radioactivity in feces, polar metabolites comprised the largest percentage of extractable fecal radioactivity after dosing with γ -HBCD (85%); polar metabolites comprised smaller percentages after dosing with α -HBCD (66%) or β -HBCD (39%). After exposure to β - and γ -HBCD, but not α -HBCD, isomerization products were detected in feces. Total extractable fecal radioactivity contained 4% β -HBCD and 7% α -HBCD after exposure to γ -HBCD, and 16% γ -HBCD after exposure to β -HBCD. No isomerization of α -HBCD was evident in any of the matrices examined. Data on the excretion of parent compound provide the strongest evidence for greater metabolism of β - and γ -HBCD compared with α -HBCD: a larger percentage of extractable fecal radioactivity was associated with parent compound after administration of α -HBCD (34%) than after dosing with β -HBCD (14%) or γ -HBCD (4%). Given that oral absorption of all three isomers was similar (85–90%), the differences in excreted parent compound appear to reflect greater metabolism of the β - and γ -isomers.

More rapid metabolism of β - and γ -HBCD relative to α -HBCD was demonstrated in *in vitro* studies using rat liver microsomes ([Abdallah et al. 2014](#); [Esslinger et al. 2011b](#); [Zegers et al. 2005](#)). Following incubation of the liver microsomes with NADPH and a 1:1:1 mixture of α -, β -, and γ -HBCD, LC/MS peaks for β - and γ -HBCD in the incubation fluid were greatly diminished after 90 minutes, whereas the peak for α -HBCD was essentially unchanged. In addition, degradation rates for enantiomeric isomers (+) α - and (-) α -HBCD were faster in rat liver microsomes than rates for (+) β -, (-) β -, or (-) γ -HBCD ([Esslinger et al. 2011b](#)). ([Abdallah et al. 2014](#)) calculated half-times of 17.14, 11.92, and 6.34 seconds for *in vitro* rat liver microsomal metabolism of α -, γ -, and β -HBCD, respectively.

Hydroxylation and debromination have been identified as metabolic pathways for HBCD isomers based on partial characterization of metabolites in animal and *in vitro* studies. Analysis of adipose, liver, muscle, and lung tissue extracts from rats exposed to 100 mg/kg-day commercial HBCD (enriched in the γ -isomer) for 28 days identified mono- and dibrominated metabolites of HBCD as well as monohydroxylated derivatives of the dibrominated metabolites pentabromocyclo-dodecene and tetrabromocyclododecene ([Brandtsma et al. 2009](#)). No sex dependent differences in metabolite profiles were observed ([Brandtsma et al. 2009](#)). Hydroxylated metabolites of β - and γ -HBCD, along with other unidentified metabolites, were also detected by LC/MS of incubation fluid after rat liver microsomes were incubated with a mixture of α -, β -, and γ -HBCD (1:1:1) and NADPH ([Zegers et al. 2005](#)).

Although specific enzymatic pathways for metabolism of HBCD have not yet been identified, results of animal *in vivo* and *in vitro* studies are consistent with hydroxylation catalyzed by CYP450 enzymes, as suggested by the observation that HBCD induced messenger ribonucleic acid (mRNA) levels for CYP2B1/2 and CYP3A1/3 in livers of rats following 28 days of dietary exposure to commercial HBCD ([Cantón et al. 2008](#); [Germer et al. 2006](#)). There are no data describing the potential contribution of gut-mediated HBCD metabolism. However, it is likely that fecal metabolites are predominantly liver-derived, as only radioactive metabolites (no parent compounds) were found in the bile of mice orally exposed to α - or γ -[14C]-HBCD ([Szabo et al. 2011a, 2010](#)).

The available data are consistent with the proposed generalized metabolic pathways shown in Figure 3-2, in which debromination occurs via undetermined enzymes and hydroxylation occurs via CYP450 oxygenases ([Brandtsma et al. 2009](#)). The generalized metabolic scheme in Figure 3-2 does account for the *in vivo* and *in vitro* evidence that isomer-specific metabolic pathways may exist in laboratory

animals or data suggesting that HBCD metabolites may be conjugated prior to excretion. (Hakk et al. 2012) found evidence for different metabolic products of γ -HBCD and α -HBCD using LC/MS analysis of extractable and nonextractable HBCD metabolites in blood, fat, brain, bile, urine, and feces collected in the toxicokinetic studies of mice exposed to radiolabeled γ -HBCD (Szabo et al. 2010) and α -HBCD (Szabo et al. 2011a). After α -HBCD exposure, two glutathione conjugates of a tri- or tetra-brominated, unsaturated C6 hydrocarbon were identified in urine, and a monohydroxylated, hexabrominated metabolite was identified in feces (Hakk et al. 2012). After γ HBCD exposure, greater numbers of metabolites were identified in urine and feces: (1) two carboxylic acid derivatives (indicative of ring opening), a hydroxylated, pentabrominated derivative, and a putative methyl mercapturate of a tetrabrominated derivative in urine; and (2) three debrominated and oxidized derivatives in feces (Hakk et al. 2012). In rat liver microsomes tested in vitro, varied monohydroxylated HBCD products for each of several tested enantiomeric substrates were detected: one from (+) α -HBCD; three from (-) α -HBCD; two from (+) γ -HBCD; and three from (-) γ -HBCD (Esslinger et al. 2011b).

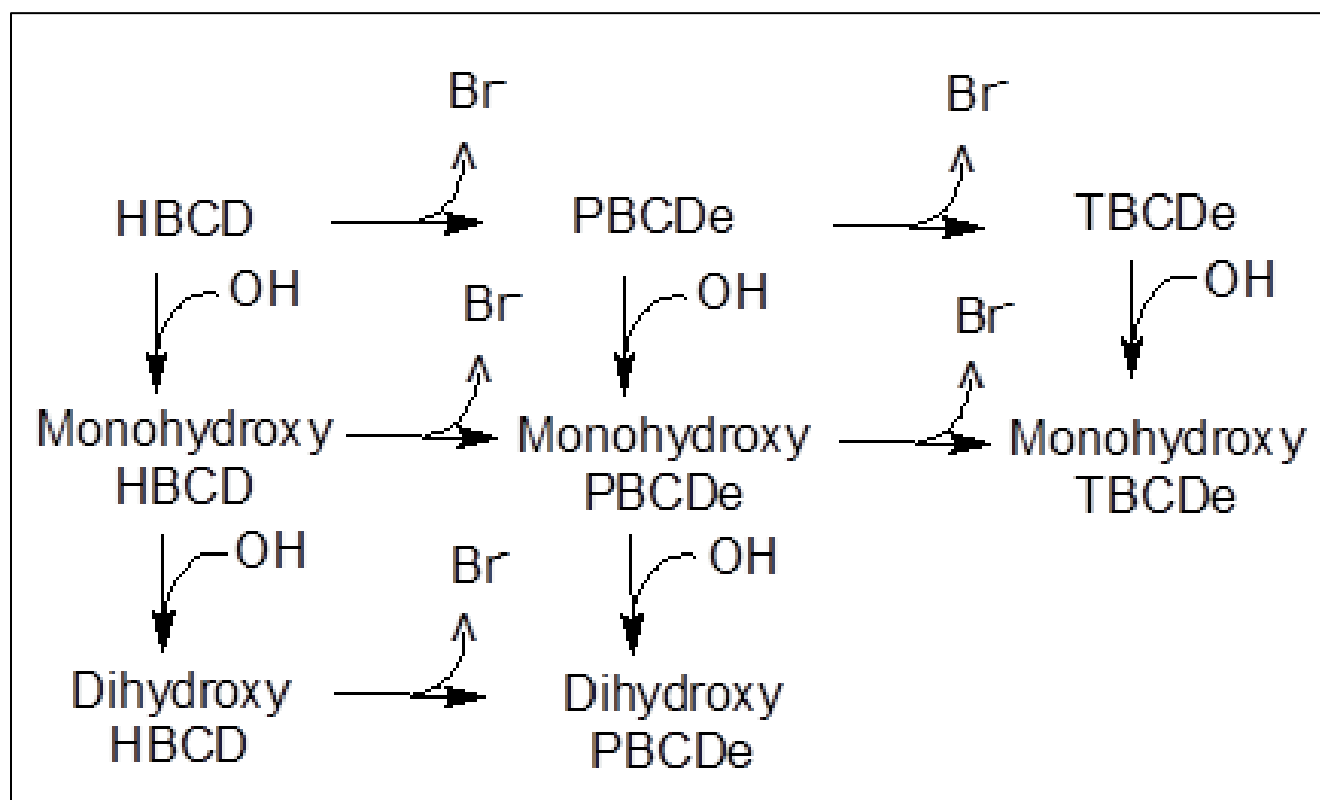

HBCD = hexabromocyclododecane; PBCDe = pentabromocyclododecene; TBCDe = tetrabromocyclododecene
Source: Adapted from (Brandsma et al. 2009).

Figure 3-2. Proposed Pathways for Metabolism of HBCD in Rats

3.2.2.1.4 Elimination

Elimination of radioactivity associated with administration of HBCD isomers is rapid, with most eliminated over the first 24 hours post administration, after either oral or i.v. dosing in female mice (Sanders et al. 2013; Szabo et al. 2011a, 2010) or oral administration in the rat (Yu and Atallah 1980). Fecal and urinary excretion are the primary excretory pathways for absorbed HBCD, although the detection of HBCD isomers in many studies of human breast milk samples indicates that breast milk fat represents an additional elimination pathway.

The fecal:urine excretion ratios (based on samples collected over 48 hours postdosing) for absorbed HBCD in mice exposed by gavage to 3 mg/kg were approximately 2.4 for α -[14C]-HBCD, 1.2 for β -[14C]-HBCD, and 2.1 for γ [14C] HBCD ([Sanders et al. 2013](#); [Szabo et al. 2011a, 2010](#)). Similar ratios were seen after i.v. dosing at the same exposure level ([Sanders et al. 2013](#); [Szabo et al. 2011a, 2010](#)). Together, urinary and fecal excretion 48 hours after dosing accounted for ~70% of the administered radioactivity (at 3 mg/kg) after exposure to the α isomer and ~90% after exposure to the β - and γ isomers ([Sanders et al. 2013](#); [Szabo et al. 2011a, 2010](#)). Excretion was essentially complete within 48 hours after either oral or i.v. dosing; studies evaluating elimination over longer time periods showed little additional excretion after 48 hours ([Szabo et al. 2011a, 2010](#)).

The overall kinetics of urinary and fecal elimination in the rat is similar to mice, but sex-dependent differences were suggested by data in rats. Forty-eight hours after dosing with [14C] γ HBCD (mixed with technical-grade HBCD containing ~75% γ -HBCD), fecal elimination accounted for 63% of radioactivity in four female rats and 95% in two male rats ([Yu and Atallah 1980](#)). Over the same time frame, urinary elimination accounted for 4.8 and 15.3% of radioactivity in female and male rats, respectively.

In female mice administered α -[14C]-HBCD by gavage, a dose-dependent shift in fecal elimination was observed ([Szabo et al. 2011a](#)). Fecal elimination accounted for about 48% of the administered radiolabel at 3 mg/kg, but only about 32% following a 100 mg/kg dose ([Szabo et al. 2011a](#)). The mechanism for the dose-dependent decrease in fecal excretion has not been identified; however, since radioactivity derived from absorbed α -[14C]-HBCD is extensively excreted into feces, this outcome suggests a possible capacity limitation in the secretion (*e.g.*, biliary) mechanism. This dose-dependency was not observed in similar studies of γ -[14C]-HBCD in mice ([Szabo et al. 2010](#)). In mice given single doses of β -[14C]-HBCD of 3, 30, or 100 mg/kg, the amount of administered radioactivity in 24-hour feces was greater after 3 mg/kg (~50%) than after 100 mg/kg (~30%), but no dose-dependent difference was noted in cumulative 96-hour feces ([Sanders et al. 2013](#)).

Biphasic elimination kinetics of radioactivity from blood and tissues of mice were observed following oral administration of α -, β -, or γ -[14C]-HBCD in corn oil vehicle ([Sanders et al. 2013](#); [Szabo et al. 2011a, 2010](#)). Tissue half-life values for the rapid phase in mice ranged from 0.1 to 0.4 days for α -HBCD, from 0.02 to 0.2 days for β -HBCD, and from 0.3 to 1 day for γ -HBCD. Terminal tissue half-life values were longer for α HBCD (range, 0.5–17 days) than for γ -HBCD (range, 0.8–5.2 days) or β -HBCD (0.2–7 days). In particular, the terminal half-lives for fat tissue were 17 days for α -HBCD, 3.6 days for γ -HBCD, and 2.5 days for β HBCD, indicating that, with repeated oral exposures, α -HBCD would be expected to accumulate in fat to a greater extent than γ HBCD or β -HBCD. Similar biphasic excretory kinetics were observed in rats following single gavage doses of commercial HBCD with γ -[14C]-HBCD ([Yu and Atallah 1980](#)). At the higher end of the range, ([Geyer et al. 2004](#)) derived an HBCD terminal elimination half-life of 64 days via estimation of human daily intake and body burden (estimate for breast milk) as well as via estimation of half-life in adipose tissue of rats. Tissue excretory kinetic data for humans are not available.

Breast milk lipid represents an additional elimination pathway for HBCD, and concentrations of HBCD in human breast milk samples have been well studied; only a few reports are summarized here. Most biomonitoring studies report total HBCD concentrations in breast milk around 1 ng/g. For example, the following lipid-normalized median concentrations were reported: 0.9 ng/g lipid (range: 0.3–2.2 ng/g) and 0.4 ng/g (range: 0.2–1.2 ng/g) for populations in the United States (Texas) in 2002 and 2004,

respectively ([Ryan and Rawn 2014](#)); 0.7 ng/g (range: 0.1–28.2 ng/g) in Ontario, Canada; 3.83 ng/g (range 1–22 ng/g) in the United Kingdom ([Abdallah and Harrad 2011](#)); 0.6 ng/g (range: 0.6–5.7 ng/g) in Belgium ([Roosens et al. 2010b](#)); and 0.86 ng/g (range: less than the limit of quantitation [LOQ] –31 ng/g) in Norway ([Thomsen et al. 2010](#)). ([Ryan et al. 2006](#)) reported that most of the HBCD detected in breast milk from Texas women was the α -isomer, whereas in Japanese women, mean lipid-normalized concentrations of α -, β -, and γ -HBCD in breast milk were 1.5, <0.1, and 2.6 ng/g, respectively ([Kakimoto et al. 2008](#)).

3.2.2.2 Description of Toxicokinetic Models

No physiologically based pharmacokinetic (PBPK) models are available for HBCD. An unpublished, empirical two-compartment open kinetic model for orally-administered ^{14}C -HBCD was developed from data collected using Sprague-Dawley rats given single oral doses of commercial HBCD labeled with γ - ^{14}C -HBCD (7–9 mg/kg) ([Yu and Atallah 1980](#)). The model did not explicitly describe the metabolism of HBCD; however, the model did estimate an elimination constant. The elimination constant accounted for metabolism of HBCD and excretion of metabolites into urine and feces. The central compartment of the model comprised blood, muscle, liver, kidney, heart, spleen, lung, gonads, and uterus, and the remaining compartment represented fatty tissues. The calculated concentrations of radioactivity in the central and fat compartments were compared with respective observed concentrations in the blood and fat. The pattern of predicted values of radiolabel in blood and fat generally reflected the pattern of observed values in blood and fat. This kinetic model addressed the distribution of radioactivity only, and did not explicitly describe metabolism.

([Aylward and Hays 2011](#)) proposed the use of lipid-adjusted tissue concentrations of HBCD as an internal dose metric that would reduce uncertainties associated with the inter- and intraspecies extrapolation based on external dose. They derived a simple first-order elimination model to estimate the steady-state lipid concentration of HBCD (in ng/g lipid) corresponding to a given daily HBCD intake (in mg/kg-day) as follows:

$$D = Cl \times Fl \times k$$

where D = chronic daily dose in mg/kg day, Cl = lipid concentration (in mg/kg lipid), Fl = fraction of body weight that is lipid (assumed to be 25%), and k = elimination rate calculated from the half-life (HL, assumed to be 64 days in days) as $k = \ln(2)/HL$.

As noted by ([Aylward and Hays 2011](#)), uncertainty in the steady-state lipid concentration of HBCD derived using this model comes from the assumed values for the half-life of HBCD (which is on the higher end of estimates from several studies (see Section 3.2.2.1.4)) and the proportion of lipid in the body. If used for purposes of interspecies extrapolation, uncertainty is also introduced by potential toxicokinetics differences across species (*e.g.*, differences in rates of metabolism of the different HBCD isomers), and consideration of whether summed or isomer-specific doses should be used. If humans clear individual isomers at a different rate than animals, and if the toxicity of individual isomers differs, the internal summed dose could either over- or under predict the response. Finally, it should be noted that a systematic examination of whether lipid-adjusted tissue concentrations better correlate with response than other measures of dose (*e.g.*, blood concentration, total concentration) has not been conducted. Based on the absence of a robust, peer reviewed PBPK model and the uncertainties inherent in the limited simple models, EPA relied on traditional route-to-route extrapolation, uncertainty factors, and dosimetric adjustment factor in the derivation of HEDs.

3.2.3 Hazard Identification

The HBCD database includes six epidemiological studies that examined associations between HBCD exposure and endpoints related to effects on the thyroid, nervous system, and male reproductive system. The evaluation of HBCD epidemiology studies by each of the five aspects of study design – study population characteristics and representativeness, exposure measures, outcome measures, confounding, and analysis – is discussed below; a summary of the results from these studies and the data quality evaluation of individual studies is provided in *Risk Evaluation for Cyclic Aliphatic Bromide Cluster (HBCD), Supplemental Information on Human Health Hazard* ([U.S. EPA 2019e](#)) and *Risk Evaluation for Cyclic Aliphatic Bromide Cluster (HBCD), Systematic Review Supplemental File: Data Quality Evaluation of Human Health Hazard Studies* ([U.S. EPA 2019n](#)). Overall, EPA determined that the epidemiological database was insufficient for dose-response assessment.

Experimental animal studies of HBCD that underwent study evaluation consisted of studies designed to examine repeat-dose oral toxicity and specialized studies of various non-cancer hazards. The majority of the experimental animal studies were considered informative and useful for characterizing the health hazards associated with exposure to HBCD, and results from these studies were extracted into evidence tables in the *Risk Evaluation for Cyclic Aliphatic Bromide Cluster (HBCD), Supplemental Information on Human Health Hazard* ([U.S. EPA 2019e](#)) and [*Risk Evaluation for Cyclic Aliphatic Bromide Cluster (HBCD), Systematic Review Supplemental File: Data Extraction Tables for Human Health Hazard Studies* ([U.S. EPA 2019g](#))]. Some limitations were noted for each study (see the *Risk Evaluation for Cyclic Aliphatic Bromide Cluster (HBCD), Systematic Review Supplemental File: Data Quality Evaluation of Human Health Hazard Studies* ([U.S. EPA 2019n](#))). Any study evaluation concerns that may have meaningfully influenced the reliability or interpretation of the results were brought forward into the synthesis of evidence for a given hazard. Two studies were considered for dose-response assessment of all endpoints ([Ema et al. 2008](#); [WIL Research 2001](#)), both of which scored a High in data evaluation.

Animal studies of ingested HBCD reported effects on the thyroid, liver, development, reproduction, nervous system, and immune system, in addition to limited studies demonstrating overt toxicity following acute exposure and sensitization/irritation. The potential health effects of inhaled HBCD have not been adequately investigated in humans or animals. There is not adequate available information to assess the carcinogenic potential of HBCD.

3.2.3.1 Non-Cancer Hazards

Data evaluation results for all studies can be found in the [*Risk Evaluation for Cyclic Aliphatic Bromide Cluster (HBCD), Systematic Review Supplemental File: Data Quality Evaluation of Human Health Hazard Studies* ([U.S. EPA 2019n](#))] and data extraction results including author-reported PODs can be found in the [*Risk Evaluation for Cyclic Aliphatic Bromide Cluster (HBCD), Systematic Review Supplemental File: Data Extraction Tables for Human Health Hazard Studies* ([U.S. EPA 2019g](#))].

For additional, more detailed information on toxicity information, weight of evidence, and mechanistic data see Section 3.2.4 and [*Risk Evaluation for Cyclic Aliphatic Bromide Cluster (HBCD), Supplemental Information on Human Health Hazard* ([U.S. EPA 2019e](#))].

3.2.3.1.1 Thyroid Effects

In humans, ([Eggesbø et al. 2011](#)) reported elevated but non-statistically significant odds ratios for increased thyroid stimulating hormone (TSH) in relation to increased HBCD levels in breast milk. Confidence intervals (CIs) around point estimates were relatively wide and a clear dose-response was not observed. Therefore, this study is considered as a no-effect finding. Similarly, other studies in

humans ([Kiciński et al. 2012](#); [Roze et al. 2009](#); [Johnson et al. 2013](#)) also did not observe any statistically significant correlations with HBCD exposure and thyroid effects among populations of various lifestages.

Although the human evidence was inconclusive, oral toxicity studies in rodents provide evidence that HBCD exposure can result in dose-related perturbations of thyroid function. In studies of HBCD-induced perturbation of serum thyroid hormone levels (*i.e.*, TSH, T4, and T3), TSH was elevated in three studies ([Saegusa et al. 2009](#); [Ema et al. 2008](#); [WIL Research 2001](#)), two of which also reported decreases in serum T4 ([Ema et al. 2008](#); [WIL Research 2001](#)). Of the several studies that measured T3 ([Saegusa et al. 2009](#); [van der Ven et al. 2009](#); [Ema et al. 2008](#); [van der Ven et al. 2006](#); [WIL Research 2001](#)), only one reported a treatment-related effect ([Saegusa et al. 2009](#)), with a statistically significant reduction observed at the highest dose. Exposure to HBCD was also associated with histopathological changes, including decreased thyroid follicle size ([Ema et al. 2008](#); [van der Ven et al. 2006](#)), follicular cell hypertrophy ([Rasinger et al. 2018](#); [Saegusa et al. 2009](#); [WIL Research 2001](#)), colloid depletion ([WIL Research, 1997](#)), and increased thyroid weight ([Saegusa et al. 2009](#); [Ema et al. 2008](#); [van der Ven et al. 2006](#); [WIL Research 2001](#)). These changes were observed across multiple rat strains, sexes, exposure durations, and study designs.

3.2.3.1.2 Liver Effects

There are no epidemiological studies that investigated the potential for an association between HBCD exposure and liver outcomes; however, some evidence for liver toxicity was identified in several rodent studies. The most consistently observed liver outcome was liver weight changes. Dose-related increases were consistently observed across species, sexes, and age from multiple studies of various designs and exposure durations ([Maranghi et al. 2013](#); [Saegusa et al. 2009](#); [Ema et al. 2008](#); [WIL Research 2001, 1997](#)). Limited support for HBCD effects on the liver are provided by histopathological examination. A subset of the rat studies ([Saegusa et al. 2009](#); [WIL Research 2001, 1997](#)) and two mouse studies ([Rasinger et al. 2018](#); [Maranghi et al. 2013](#)) reported increased vacuolation (generally of minimal to mild severity) in HBCD-exposed animals, but these responses were not dose-related. Other histological findings were less frequently observed and included some additional evidence of fatty change (steatosis) ([Yanagisawa et al. 2014](#)), hypertrophy ([Yanagisawa et al. 2014](#); [WIL Research 1997](#)), and inflammation ([Maranghi et al. 2013](#)). In a single-dose mouse study, only 49.5 µg/kg of HBCD administered for 28 days in a fish-based diet also resulted in a statistically significant increase of lymphocytic infiltration, and hyperaemic vessels ([Rasinger et al. 2018](#)). Of note, ([Yanagisawa et al. 2014](#)) scored Unacceptable in data quality evaluation due to relying on an intermittent 1x/week dosing schedule, however observations from that study still contribute to hazard identification. Statistically or biologically significant elevations in serum liver enzymes were not consistently associated with HBCD exposure in rats or mice ([Yanagisawa et al. 2014](#); [WIL Research 1997](#)), although a dose-responsive (but non-statistically significant) increase in alanine aminotransferase (ALT) was observed in female rats and statistically-significant elevated gamma-glutamyl transferase (GGT) was observed in the high dose group of both sexes ([WIL Research 2001](#)).

3.2.3.1.3 Reproductive Effects

Female reproductive effects

There are no epidemiological studies evaluating female reproductive outcomes. In animals, some evidence for an association between HBCD exposure and female reproductive system effects comes from findings of effects on fertility and pregnancy outcome as reported in a two-generation reproductive toxicity study for HBCD in rats ([Ema et al. 2008](#)); signs of reproductive toxicity included dose-related decreases in pregnancy incidence in F0 and F1 generations, and a statistically significant incidence of total litter loss in multiple high-dose F1 dams. Decreased primordial follicles were also observed in the

F1 dams (this endpoint was not evaluated in F0 females). In a single-dose study, only 49.5 µg/kg of HBCD administered to female mice for 28 days in a fish-based diet also resulted in histopathological changes to the uterus, decreased oestradiol 17β, and an increased oestradiol 17β /testosterone ratio ([Rasinger et al. 2018](#)).

Male reproductive effects

Two epidemiological studies investigated reproductive endpoints in male subjects from a birth cohort and adult males seeking infertility treatments ([Johnson et al. 2013](#); [Meijer et al. 2012](#)); these studies provide some evidence of a weak to moderate negative correlation between HBCD exposure and serum testosterone or sex hormone binding globulin (SHBG) levels, but not other hormones.

In animal studies, no consistent effects on male reproductive organ weights, reproductive development, hormone concentrations, or spermatogenic measures were associated with 28-day, 90-day, or developmental exposure to HBCD ([Saegusa et al. 2009](#); [van der Ven et al. 2009](#); [Ema et al. 2008](#); [van der Ven et al. 2006](#); [WIL Research 2001](#)).

3.2.3.1.4 Developmental Effects

There are no epidemiological studies evaluating developmental-specific outcomes. However, several studies of rodents exposed during gestation and lactation provide some evidence of developmental effects associated with HBCD, including reduced offspring viability ([Ema et al. 2008](#)), decreased pup body weight ([Maranghi et al. 2013](#); [Saegusa et al. 2009](#); [van der Ven et al. 2009](#); [Ema et al. 2008](#)), altered development of the skeletal system, and delayed eye opening ([Ema et al. 2008](#)). Evidence of adverse developmental effects is based on findings of reduced offspring survival and decreased pup body weight. Reduced viability was observed in F2 pups of the two-generation study by ([Ema et al. 2008](#)); the decreases in viability were dose-related and observed on both post-natal day (PND) 4 and 21. The fact that effects were seen only in F2 offspring is consistent with decreased viability manifesting after multigenerational exposure, although that hypothesis cannot be established based on the current developmental literature for HBCD (*i.e.*, a single two-generation study). Effects on pup body weight were demonstrated in several studies in rats using different strains and exposure durations ([Saegusa et al. 2009](#); [van der Ven et al. 2009](#); [Ema et al. 2008](#)). Other developmental effects, including changes in bone development and delayed eye opening, were only reported in a single study and with a less clear dose-response relationship ([van der Ven et al. 2009](#); [Ema et al. 2008](#)).

3.2.3.1.5 Neurological Effects

Developmental exposure

In an epidemiological birth cohort study in the Netherlands ([Roze et al. 2009](#)), the associations between maternal HBCD levels (week 35 of pregnancy) and multiple neuropsychological domains were inconsistent across the measured domains. A second epidemiological study in adolescents in Belgium ([Kiciński et al. 2012](#)) did not observe associations between HBCD levels and six neurobehavioral measures. In rodents, there is some evidence to support HBCD-mediated neurotoxicity following developmental exposure. Early-life exposure in rodents affected several measures of neurotoxicity, including neurodevelopmental milestones ([Miller-Rhodes et al. 2014](#); [Ema et al. 2008](#)), locomotor activity and executive function ([Miller-Rhodes et al. 2014](#); [Ema et al. 2008](#); [Eriksson et al. 2006](#)), and other neurological outcomes related to changes in auditory sensitivity, dopaminergic system function ([Lilienthal et al. 2009](#)), and brain weight ([van der Ven et al. 2009](#); [Ema et al. 2008](#)). ([Eriksson et al. 2006](#)) evaluated effects in young adult (3-month-old) mice that were administered a single dose of HBCD on PND 10, which corresponds with a period of rapid growth and maturation for motor and sensory neural networks in mice.

Adult exposure

There are no epidemiological studies evaluating nervous system effects following adult exposure. In animals, four studies in rats or mice exposed only as adults found no changes in the nervous system endpoints evaluated (*i.e.*, striatal levels of dopamine, Functional Occupational Battery (FOB), locomotor activity, brain weight, or gross brain pathology) ([Genskow et al. 2015](#); [van der Ven et al. 2006](#); [WIL Research 2001, 1997](#)). Notably, HBCD was cytotoxic to neuronal cell lines and reduced expression of dopaminergic transporters in mice despite not affecting overall levels of striatal dopamine ([Genskow et al., 2015](#)). Results on locomotor activity indicated that mice failed to habituate to the novel environment of the testing arena, however this result was not confirmed in a longer duration study ([Miller-Rhodes et al. 2014](#); [Ema et al. 2008](#)).

3.2.3.1.6 Immune System Effects

There are no epidemiological studies evaluating immune system effects. In animals, there is some evidence of HBCD-mediated immune system effects. The strongest evidence comes from alterations in IgG antibodies, a functional measure of immune system response, in rats exposed to HBCD during development ([Hachisuka et al. 2010](#); [van der Ven et al. 2009](#); [Ema et al. 2008](#)). Changes were also observed in other indicators of immunomodulation, including changes in immune organ weights (thymus and spleen), changes in hematological parameters, and histopathology. Decreased thymus weight (*e.g.*, thymic atrophy), especially during development, have the potential to cause significant chronic long-term immune effects. These observed changes were variable and inconsistent (including directionality) however in both developing and adult animals ([Hachisuka et al. 2010](#); [van der Ven et al. 2009](#); [Ema et al. 2008](#); [van der Ven et al., 2006](#)). Recent mechanistic studies ([Almughamsi and Whalen 2016](#); [Anisuzzaman and Whalen 2016](#); [Canbaz et al. 2016a](#); [Koike et al. 2016](#)) along with bioassays from the EPA ToxCast Dashboard (<https://comptox.epa.gov/dashboard/dsstoxdb/results?search=hbcd#invitrodb>) demonstrate changes in cytokine secretion and cell surface marker expression from immune cells following HBCD exposure; these changes were not always consistent however and could not be directly linked to any particular toxicological outcome.

3.2.3.1.7 Overt Toxicity Following Acute/Short Term Exposure

Acute/short term studies in animals consist of either single or short-term exposures (14-days or less) at high doses specifically designed for assessing the dose at which lethality occurs or for examining overt toxicity. Several acute lethality studies in rodents and rabbits by the oral, dermal, and inhalation routes with HBCD are available ([GSRI 1994](#); [Momma et al. 1993](#); [BASF 1990](#); [IRDC 1978a, b, c](#); [Lewis and Palanker 1978a](#)). The acute lethality of HBCD is relatively low via the oral, dermal and inhalation routes. Oral LD₅₀ values are equal to or greater than 680 mg/kg-bw, in rats and mice. Various neurotoxic signs observed in oral studies included ptosis (upper eyelid drooping), apathy, trembling, and hypoactivity. Additional effects included lacrimation (tears), diarrhea, and inflammation ([U.S. EPA 2015a](#)). No lethality was observed in rabbits following acute dermal exposure to doses as high as 8.0 g/kg ([Lewis and Palanker 1978a](#)). Several inhalation studies have demonstrated no mortality in rats following exposure to up to 200 mg/L (200,000 mg/m³) HBCD for 1-4h ([U.S. EPA 2015a](#)), with only minor symptoms observed (such as eye squint, slight dyspnea, salivation, lacrimation, and nasal discharge). A recent study confirmed that the HBCD LC₅₀ for 4-h inhalation exposure in rats is greater than 5000 mg/m³ ([Song et al. 2016](#)). In that same study, HBCD also did not produce any adverse effects (clinical signs or organ-specific pathology) up to 2000 mg/m³ administered 6h/day for 14 days.

3.2.3.1.8 Sensitization/Irritation

The available literature indicates that HBCD is not a dermal irritant in guinea pigs ([Lewis and Palanker 1978b](#)). Acute eye irritation studies in rabbits showed HBCD to be a mild transient ocular irritant ([Lewis](#)

[and Palanker 1978b](#)), (Gulf South Research Institute, 1988). One study ([Momma et al. 1993](#)) found HBCD to be a mild skin allergen in guinea pigs, however ([Microbiological Associates 1996b](#)) did not observe any sensitization reaction at the same dose (5%) or neat in corn oil (~100%) ([NRC 2000b](#)). Two mechanistic studies suggest that HBCD enhances the allergenic response to dust-mites ([Canbaz et al. 2016a](#); [Canbaz et al. 2016b](#)), and there is some evidence of HBCD stimulating the release of various pro-inflammatory cytokines that may promote allergic responses ([Almughamsi and Whalen 2016](#); [Anisuzzaman and Whalen 2016](#); [Canbaz et al. 2016a](#); [Koike et al. 2016](#)).

3.2.3.2 Genotoxicity and Cancer Hazards

Genotoxicity

A limited number of studies have investigated the genotoxicity of HBCD. The majority of these studies were standard Ames tests for detecting mutagenic potential in the bacteria (*Salmonella typhimurium*.) These tests, which employ different strains of bacteria that have been developed with pre-existing mutations, including *S. typhimurium* TA98, TA100, TA1535, TA1537, and TA1538, are referred to as reversion assays ([Maron and Ames 1983](#)). Most of these assays conducted with HBCD yielded negative results ([Huntingdon Research Center 1990](#); [IBT Labs 1990](#); [Litton Bionetics 1990](#); [Pharmakologisches Institut 1990](#); [SRI International 1990](#); [Zeiger et al. 1987](#)). Negative results were also obtained in ([GSRI \(1978\)](#)), ([IBT Labs, 1990](#)) and ([Huntingdon Research Center \(1990\)](#)), however these studies scored Unacceptable. Among the few assays performed to determine the genotoxicity of HBCD in eukaryotic systems, one in yeast ([Litton Bionetics 1990](#)) and one detecting chromosomal aberrations in human peripheral lymphocytes *in vitro* ([Microbiological Associates 1996a](#)) were negative, even when tested at cytotoxic concentrations. A single *in vivo* mouse micronucleus test following intraperitoneal (i.p.) injections of HBCD ([BASF 2000](#)) was also negative, however the full study was unavailable for data quality review.

Some positive results have been reported. *S. typhimurium* strain TA1535 was positive for reverse mutations at the highest dose only using a liquid residue of HBCD in DMSO ([IBT Labs 1990](#)), and strain TA100 was positive also at the highest dose using an unidentified mixture characterized only as HBCD bottoms in acetone ([Ethyl Corporation 1990b](#)). In this same study, TA1535 was positive at ≥ 100 $\mu\text{g}/\text{plate}$ without addition of an S9 microsomal fraction ([Ethyl Corporation 1990b](#)). The number of revertants increased with dose. This was the only Ames study to report dissolving the test article in a solvent other than DMSO (in this case, acetone). DMSO is a free-radical scavenger and can potentially obscure genetic damage due to oxidative radicals. Both strains TA1535 and TA100 were designed to be sensitive to detecting reversions by base substitution, a type of genetic lesion that can result from oxidative DNA damage due to reactive oxygen species (ROS). However, there is only limited evidence in the literature indicating that HBCD exposure may induce oxidative stress ([An et al. 2013](#); [Hu et al. 2009b](#)).

In mammalian systems, a reverse mutation assay with Chinese hamster ovary (CHO) Sp5 and SPD8 cell lines exposed to HBCD ([Helleday et al. 1999](#)) yielded positive results. These two clones exhibit a partial duplication of the *hprt* gene, causing lethality unless a reversion occurs, either via homologous recombination (SPD8) or non-homologous recombination (Sp5). A statistically significant, dose-dependent increase in reversion frequency was observed in both clones, although at higher doses, there was a significant inhibition of cloning efficiency. In addition, a test of unscheduled DNA synthesis with rat hepatocytes exposed to HBCD bottoms was positive ([Ethyl Corporation 1990a](#)) as well as comet assays in human hepatocyte L02 and hepatoma HepG2 cells ([An et al., 2013](#); [Huang et al. 2016](#)) and each study showed a dose-responsive increase in response. Interestingly a follow-up study by An et al. ([2016](#)) found that pre-incubation of L02 cells with sub-mutagenic doses of HBCD promoted adaptive responses that protect against genotoxic effects of subsequent high doses.

It is noteworthy that in these studies, the positive results were dose-dependent, observed at nontoxic doses, and in two assays, specific for detecting mutations. However, the tests in bacteria and yeast along with the single mammalian *in vivo* study ([BASF 2000](#)) were predominantly negative.

Carcinogenicity

The carcinogenic potential of HBCD was not evaluated in any epidemiological studies. The only experimental animal study to examine cancer endpoints is an 18-month dietary study in mice that was only available as an incomplete report ([Kurokawa et al. 1984](#)). That study concluded that HBCD was not carcinogenic at dietary concentrations of 100, 1000, and 10,000 ppm.

Full details for all studies are provided in *Risk Evaluation for Cyclic Aliphatic Bromide Cluster (HBCD), Supplemental Information on Human Health Hazard* ([U.S. EPA 2019e](#)).

3.2.4 Weight of the Scientific Evidence

For more detailed discussion on weight of evidence and mode of action, see *Risk Evaluation for Cyclic Aliphatic Bromide Cluster (HBCD), Supplemental Information on Human Health Hazard* ([U.S. EPA 2019e](#)).

3.2.4.1 Non-Cancer Hazards

3.2.4.1.1 Thyroid Effects

The human database was considered too limited for drawing conclusions regarding the relationship between HBCD exposure and thyroid effects. Several human epidemiological studies investigated the association between HBCD exposure and alteration of thyroid hormones at various lifestages. ([Eggesbø et al. 2011](#)) reported an elevated but non-statistically significant odds ratio for increased TSH in relation to increased HBCD levels in breast milk, but confidence intervals around point estimates were relatively wide and a clear dose-response was not observed. Other studies also found no significant correlations with HBCD exposure and thyroid effects. In general, these HBCD studies were limited by small sample sizes ([Kim and Oh 2014](#); [Johnson et al. 2013](#); [Roze et al. 2009](#)) or HBCD exposure quantification methods ([Kim and Oh 2014](#); [Kiciński et al. 2012](#)).

Animal toxicity studies provided evidence of thyroid perturbation associated with HBCD exposure, including altered levels of thyroid hormones, histological changes, and increased thyroid weight, with effects observed across multiple lifestages. Increased TSH is a sensitive early indicator of disruption of the thyroid hormone economy, including decreased thyroid hormone synthesis or secretion, decreased serum concentrations of T4, or decreased deiodination of T4 to T3 in peripheral tissues. A pattern of increased TSH and decreased T4 that was observed in a two-generation reproductive study ([Ema et al. 2008](#)) is consistent with the multi-loop feedback system of the HPT-axis ([Fisher and Nelson 2012](#)). A similar pattern of effect in TSH and T4 was reported by ([WIL Research 2001](#)); however, this study scored a low in data quality for thyroid outcomes despite scoring a high in data quality for other endpoints due to inadequate reporting of thyroid hormone measurement methods, questionable control data (unrealistically low TSH measurements), inconsistent data reporting across tables, and small sample sizes. Although these two studies did not observe significant changes in T3, this finding is not surprising given that T4 is the major thyroid hormone in the blood and most T3 is created by deiodination of T4 in the peripheral tissues ([Rosol et al. 2013](#)). In addition to changes in serum hormone levels, evidence of thyroid activation, including histopathological changes ([Saegusa et al. 2009](#); [Ema et al. 2008](#); [van der Ven et al. 2006](#); [WIL Research 2001, 1997](#)) and increased thyroid weight ([Saegusa et al. 2009](#); [Ema et al. 2008](#); [van der Ven et al. 2006](#); [WIL Research 2001](#)), were observed in both sexes and across studies of different exposure durations (subchronic, short-term, and one- and two-generations).

Regulation of thyroid hormones is complex and homeostasis is largely maintained via hypothalamic-pituitary-thyroid (HPT) axis feedback mechanisms. Reductions in serum T3 or T4 triggers release of TSH from the pituitary, which stimulates the thyroid gland to increase secretion of T3 and T4 stores

from the colloid ([Fisher and Nelson 2012](#)). Decreased T4 is expected to be the primary driver of HBCD-mediated thyroid effects that triggers release of TSH. Reduced T4 alone can lead to adverse effects on the developing nervous system even in the absence of changes to T3 and TSH levels (although a statistically significant increase in TSH levels following HBCD exposure was observed in parallel in ([Ema et al. 2008](#))). Indeed, this is supported by mechanistic studies that indicate that observed decreases in T4 may be largely driven by hepatic induction of enzymes that metabolize this hormone ([Shelby et al. 2003](#); [Vansell and Klaassen 2002](#); [Kelly 2000](#)). Furthermore, reduced T4 levels can also play a key role in other downstream effects such as liver toxicity, developmental neurotoxicity, as well as other developmental processes ([Finken et al. 2013](#); [Julvez et al. 2013](#); [Román et al. 2013](#); [Henrichs et al. 2010](#); [Haddow et al. 1999](#)). A few studies demonstrate that HBCD may induce these human health hazards downstream of thyroid hormone dysregulation through direct activation of the DNA-binding thyroid receptor. HBCD-mediated activation of the thyroid receptor has been shown to affect gene expression, cell proliferation, and morphological development ([Hamers et al. 2006](#); [Schriks et al. 2006](#)).

Mechanistic Evidence

Available mechanistic data suggest that HBCD may interfere with normal thyroid hormone function. Indirectly, HBCD may decrease circulating thyroid hormone levels by inducing liver xenobiotic enzymes that are responsible for metabolizing thyroid hormones. Directly, HBCD may act via the thyroid receptor and regulate thyroid-responsive genes. Other related, but less supported possible mechanisms, include competition for thyroid hormone binding proteins and dysregulation of deiodinases. See [*Risk Evaluation for Cyclic Aliphatic Bromide Cluster (HBCD)*, *Supplemental Information on Human Health Hazard* ([U.S. EPA 2019e](#))] for more details.

Relevance and sensitivity of thyroid hormone effects in rodents compared to humans

There is debate as to whether rodents are more sensitive than humans to thyroid hormone disruption. A review on thyroid disruption by perchlorate by the National Academies of Science (NAS) ([NRC 2005](#)) concludes that while thyroid function and regulation are qualitatively similar in rats and humans, differences in clearance rates and thyroid stimulation require careful consideration for interpreting thyroid hormone or histopathology changes in quantitative risk assessment. This NAS assessment also states that humans are less susceptible than rats to disruption of thyroid hormone based on these differences. This review was targeted to the effects of perchlorate however, with all conclusions caveated in that they apply specifically to perchlorate exposure and the formation of thyroid tumors, which is not an expected outcome of HBCD exposure. The mode of action (MOA) for perchlorate involves inhibition of sodium-iodide symporter (NIS)-mediated iodide uptake in the thyroid, and NAS recommends use of this effect as the basis for the perchlorate point of departure (POD). There is no evidence that HBCD modulates thyroid hormones through inhibition of iodide uptake.

Available mechanistic evidence suggests that HBCD is likely to function at least partially indirectly through upregulation of the enzyme uridine diphosphate glucuronyl transferase (UGT) ([Crump et al., 2010](#); [Cantón et al., 2008](#); [Crump et al., 2008](#); [Palace et al., 2008](#); [van der Ven et al., 2006](#)) resulting in increased thyroid hormone metabolism and excretion ([Kato et al. 2008](#); [Klaassen and Hood 2001](#)). This mechanism would be expected to act on thyroid hormone levels directly, unlike the MOA for perchlorate. Additionally, a review of the HPT axis across species published more recently than the NAS review ([Zoeller et al. 2007](#)) states that there is minimal evidence linking biochemical and metabolic differences in thyroid hormones (due primarily to reduce serum binding proteins in rodents) to differences in sensitivity among rodents and humans except on a MOA-specific basis. The review concludes that “total T4 in rodents is a valid measure of thyroid function if serum binding proteins are not being affected by the treatment under study.” While there is conflicting limited mechanistic evidence

investigating whether HBCD may affect transcription of the serum binding protein transthyretin (TTR) ([Crump et al., 2008](#); [Hamers et al., 2006](#)), the majority of mechanistic data supports an MOA involving increased thyroid hormone clearance through induction of UGT.

A review by the National Institute of Environmental Health Sciences (NIEHS) ([Choksi et al. 2003](#)) concludes that while the thyroid system is highly conserved between rodents and humans in general, differences that need to be considered in extrapolating results from animal data include: “metabolic turnover rates, basal TSH levels, sodium-iodide symporter sensitivities, windows of susceptibility, the role of the thyroid system on reproductive tract development and function, and the magnitudes of thyroid system changes that result in adverse health effects, among others. Additionally, thyroid hormone glucuronidation by UGT is only a minor pathway in humans under euthyroid conditions, although this can be modulated by upregulated T3 levels or xenobiotic exposure.

Biochemical and metabolic differences among adult rodents and humans may result in quantitative differences in dose-response and downstream outcomes as a result of decreased serum hormones levels. Thyroid hormone levels have much shorter half-lives in adult rats compared to humans, potentially due to a lack of high-affinity T4 binding proteins (*e.g.*, thyroxine-binding globulin, TBG), possibly making T4 more susceptible to removal ([Zoeller et al. 2007](#)). Importantly, TBG is expressed in neonatal rodents and only decreases following weaning. TBG increases during pregnancy in both rats and humans, while only in mice does TBG decrease throughout pregnancy ([Choksi et al. 2003](#)). In general, there are significantly fewer differences in thyroid hormone regulation between rodents and humans during development. In humans, mild to moderate maternal thyroid insufficiency (*i.e.*, low T4 levels) is associated with higher risk for persistent cognitive and behavioral deficits in children ([Finken et al. 2013](#); [Julvez et al. 2013](#); [Román et al. 2013](#); [Henrichs et al. 2010](#); [Haddow et al. 1999](#)). Similar effects have been described in animal studies, with modest reductions in maternal T4 during gestation resulting in behavioral alterations, learning deficits, and neuroanatomical changes in offspring ([Gilbert et al. 2014](#); [Gilbert et al. 2013](#); [Gilbert 2011](#); [Liu et al. 2010](#); [Ausó et al. 2004](#)). Therefore, developmental effects of thyroid disruptors following gestational exposure are expected to be highly comparable between rats and humans, with substantially increased susceptibility in developing individuals of both species compared to adults. Additionally, because rats are more altricial than humans, thyroid maturation (and thyroid hormone-associated growth and development) proceeds later in rats than humans. Consequently, human offspring may be more susceptible *in utero* to many developmental outcomes that were observed only postnatally in rats (*e.g.*, mortality, reduced body weight). In contrast, in some cases humans exposed only neonatally may have developed compensatory mechanisms that are not yet fully formed in newborn rodents.

Overall the weight-of-evidence indicates that rodents are a relevant model for assessment of thyroid disruption by HBCD. While there are some significant differences in the thyroid system between rodent and human adults, gestational HBCD exposure is likely to result in qualitatively and quantitatively similar developmental outcomes. Perturbations in thyroid hormones observed in animal studies following HBCD exposure as well as effects observed in mechanistic studies [*Risk Evaluation for Cyclic Aliphatic Bromide Cluster (HBCD), Supplemental Information on Human Health Hazard* ([U.S. EPA 2019e](#))], support EPA conducting dose-response analysis on this endpoint. In addition, the other hazards associated with HBCD toxicity are likely downstream results of the dysregulation of thyroid hormones and the HPT axis, key events in the associated adverse outcome pathway leading to multiple adverse outcomes ([Forhead and Fowden 2014](#); [Gilbert and Zoeller 2010](#); [Hulbert 2000](#)). This hazard endpoint is an upstream event of other adverse outcomes and was carried forward for dose-response analysis.

3.2.4.1.2 Liver Effects

No epidemiological studies are available to inform potential adverse effect of HBCD on liver. In laboratory animals, there is evidence for liver toxicity. The most consistent hepatic change was increased liver weight, which was observed in the majority of studies, in both sexes, in both rats and mice, and following both adult and developmental exposures ([Maranghi et al. 2013](#); [Saegusa et al. 2009](#); [van der Ven et al. 2009](#); [Ema et al. 2008](#); [van der Ven et al. 2006](#); [WIL Research 2001, 1997](#)). Although the toxicological significance of increased liver weight is not clear, these data are supported by some histological and mechanistic data. Vacuolation was observed in several rat studies ([Saegusa et al. 2009](#); [WIL Research 2001, 1997](#)) and one mouse study ([Maranghi et al. 2013](#)). The content of the hepatocellular vacuoles was investigated by ([WIL Research 2001](#)) and characterized as lipid. Studies reported evidence of inflammatory effects in the liver of mice following HBCD exposure through a standard chow diet ([Maranghi et al. 2013](#)) and enhancement of hepatic fatty changes (steatosis) in mice when HBCD was added to a high-fat diet ([Yanagisawa et al. 2014](#)). Statistically or biologically significant elevations in serum liver enzymes were not associated with HBCD exposure in rats or mice ([Yanagisawa et al. 2014](#); [WIL Research 2001, 1997](#)).

Mechanistic Evidence

HBCD may dysregulate lipid metabolism and transport based on the presence of lipid vacuoles in hepatocytes ([WIL Research, 2001](#)) along with observed increased triglycerides and elevated expression of lipid metabolism and transport genes ([Yanagisawa et al. 2014](#)). Mechanistic evidence also suggests a potential role of HBCD in the induction of hepatic microsomal enzymes, a proposed key event in initiating the perturbation of the HPT axis that leads to reduced T4 levels (see Thyroid section above). Liver toxicity appears to be especially apparent following a high-fat diet, which may represent a susceptibility factor for HBCD toxicity ([Bernhard et al. 2016](#)).

HBCD has been shown to induce the expression of several hepatic microsomal enzymes ([Crump et al. 2010](#); [Crump et al. 2008](#); [Germer et al. 2006](#)), which may result in interplay between liver and thyroid hormone effects. HBCD may also impair lipid homeostasis. Several studies observed increased vacuolation in hepatocytes ([Maranghi et al. 2013](#); [Saegusa et al. 2009](#); [WIL Research 2001, 1997](#)) and the only study to evaluate vacuole contents indicated that they predominantly consisted of lipid ([WIL Research 2001](#)). Additionally, various gene expression studies lend supportive evidence for HBCD-mediated disruption of genes involved in lipid metabolism and transport. HBCD-mediated alterations in the regulation of lipid metabolism have also been observed in avian species and in vitro. The lack of increased incidence of necrosis or apoptosis and/or serum enzymatic markers of hepatocellular damage suggests that HBCD is not highly cytotoxic in liver. However, there is evidence to suggest the exposure to HBCD can increase the production of reactive oxygen species (ROS). See [*Risk Evaluation for Cyclic Aliphatic Bromide Cluster (HBCD), Supplemental Information on Human Health Hazard* ([U.S. EPA 2019e](#))] for more details.

Overall, liver toxicity following HBCD exposure is supported by observations in animal and mechanistic studies. Additionally, liver toxicity may be exacerbated when HBCD exposure is combined with a high-fat diet. Therefore, this hazard was carried forward for dose-response analysis.

3.2.4.1.3 Reproductive Effects

Female Reproductive Effects

The potential for HBCD to affect the female reproductive system has not been investigated in humans. There is evidence for female reproductive hazard in animals, primarily based on effects observed in a two-generation reproductive toxicity study ([Ema et al. 2008](#)). ([Ema et al. 2008](#)) reported dose-related

decreased incidence of pregnancy in the F0 and F1 generations and a reduced pool of primordial follicles in the F1 generation. The only other study that looked at a measure of pregnancy incidence was a one-generation study ([van der Ven et al. 2009](#)) that reported no significant dose-response trend on successful matings (*i.e.*, the rate of matings that results in offspring). Because ([van der Ven et al. 2009](#)) used a lower dose range than ([Ema et al. 2008](#)), the lack of effects on reproductive performance from this study is only informative of an absence of effects at lower doses and does not contradict the outcomes observed in ([Ema et al. 2008](#)) at higher doses. HBCD exposure did not affect other fertility and pregnancy outcomes (*e.g.*, gestational duration, number of implantation sites, litter size) ([Saegusa et al. 2009](#); [van der Ven et al. 2009](#); [Ema et al. 2008](#)). Investigation of other female reproductive outcomes provides little supportive evidence of reproductive toxicity. Statistically significant changes in sex hormone levels were limited to increased follicle-stimulating hormone (FSH) as reported by ([Ema et al. 2008](#)) and increased testosterone as reported by ([Maranghi et al. 2013](#)); levels of other hormones showed no dose-related changes. Evidence of changes in time to vaginal opening, a measure of reproductive differentiation and development, were inconsistent across studies. No consistent effects were observed on measures of reproductive organ weight.

Mechanistic Evidence

Human and rodent cell culture models provide some evidence to support the potential for HBCD to alter the function of several reproductive hormones. Various studies suggest that HBCD may act as an androgen receptor agonist ([Christen et al. 2010](#)) and a disruptor of FSH are mixed. In addition to hormone receptor level effects, several studies indicate that HBCD may also perturb enzymes involved in the synthesis and metabolism of reproductive hormones. See [*Risk Evaluation for Cyclic Aliphatic Bromide Cluster (HBCD), Supplemental Information on Human Health Hazard* ([U.S. EPA 2019e](#))] for more details.

Evidence for female reproductive toxicity following HBCD exposure is supported by observations in animal and mechanistic studies. Therefore, this hazard was carried forward for dose-response analysis.

Male Reproductive Effects

Both human and animal evidence for male reproductive effects were insufficient for drawing conclusions regarding the relationship between HBCD exposure and male reproductive toxicity. Two epidemiological studies ([Johnson et al. 2013](#); [Meijer et al. 2012](#)) provided limited evidence of male reproductive effects (effects on serum testosterone and SHBG levels) associated with HBCD exposure in humans, and animal studies revealed inconsistent effects in all measures of male reproductive endpoints. Limited mechanistic data on male reproductive toxicity are available [*Risk Evaluation for Cyclic Aliphatic Bromide Cluster (HBCD), Supplemental Information on Human Health Hazard* ([U.S. EPA 2019e](#))].

Evidence for male reproductive toxicity following HBCD exposure in animal studies was limited and inconsistent. Therefore, this hazard was not considered further for dose-response analysis.

3.2.4.1.4 Developmental Effects

Studies were not identified that looked at developmental-specific outcomes in humans. Epidemiological studies pertaining to other organ-/system-specific hazards following developmental exposure are discussed in Sections 3.2.3.1.1 (thyroid), 3.2.3.1.3 (male reproduction), and 3.2.3.1.5 (nervous system).

Animal toxicity studies provide evidence of a developmental hazard. These data suggest that early life exposure to HBCD can affect various developmental outcomes, including reduced offspring viability ([Ema et al. 2008](#)) and decrements in pup weight ([Maranghi et al. 2013](#); [Saegusa et al. 2009](#); [van der Ven](#)

[et al. 2009](#); [Ema et al. 2008](#)). Ontogeny of developmental landmarks were either unaffected (*i.e.*, incisor eruption or pinna unfolding) or effected inconsistently (*i.e.*, eye opening) ([Ema et al. 2008](#)). The support for developmental toxicity is strongest in F2 animals, with effects seen in both sexes in the high-dose group. This evidence is consistent with developmental thyroid hormone disruption.

Mechanistic data

HBCD exposure in zebrafish is associated with increased ROS generation and induction of apoptotic cell pathways resulting in malformations and reduced viability ([Du et al. 2012b](#); [Deng et al. 2009](#); [Hu et al. 2009a](#)) as well as effects on cardiac function ([Wu et al. 2016a](#); [Wu et al. 2013](#)). Disruption of thyroid hormones is strongly associated with downstream developmental effects including growth restriction, skeletal development, and neurological abnormalities. Although there is limited mechanistic data overall regarding HBCD-mediated effects on development, perturbations in thyroid hormones could lead to developmental toxicity because of the role thyroid hormones play during development ([Zoeller et al., 2007](#); [Forhead and Fowden 2014](#); [Gilbert and Zoeller 2010](#); [Hulbert 2000](#)). See [*Risk Evaluation for Cyclic Aliphatic Bromide Cluster (HBCD), Supplemental Information on Human Health Hazard* ([U.S. EPA 2019e](#))] for more details.

Evidence for developmental toxicity following HBCD exposure is supported by observations in animals and mechanistic data on HBCD and thyroid hormone disruption. Therefore, this hazard was carried forward for dose-response analysis.

3.2.4.1.5 Neurological Effects

Developmental Exposure

The two available epidemiological studies did not find consistent effects on the nervous system following developmental exposure ([Roze et al. 2009](#); [Kiciński et al. 2012](#)). Therefore, the available human evidence ranges from equivocal to negative.

Some evidence of potential nervous system effects of HBCD comes from early-life exposure studies in rodents. Perinatal HBCD exposure altered neurodevelopmental milestones ([Miller-Rhodes et al. 2014](#); [Ema et al. 2008](#)), elicited changes in locomotor activity and executive function that persisted into adulthood ([Miller-Rhodes et al. 2014](#); [Ema et al. 2008](#); [Eriksson et al. 2006](#)), and affected other neurological endpoints related to changes in auditory sensitivity, dopamine system function ([Lilienthal et al. 2009](#)), and brain weight ([van der Ven et al. 2009](#); [Ema et al. 2008](#)). Across the database, nervous system effects were observed in both sexes and across a wide range of doses and exposure durations (ranging from acute to multigenerational). However, interpretation of these data was complicated by study quality issues, including lack of blinding, poor health in the animals, pooling of data across timepoints, and failure to measure potential confounders. Furthermore, there were considerable inconsistencies in outcomes across studies that evaluated similar neurodevelopmental endpoints, including development of sensorimotor reflexes, locomotor activity, learning ability in swim maze tests, and brain weight.

Mechanistic Evidence

Thyroid hormones are known to play a key role in development of the vertebrate central nervous system, and perinatal exposure to thyroid-disrupting chemicals has been shown to have lasting effects on cognitive and behavioral outcomes ([Gilbert et al. 2012](#); [Howdeshell 2002](#); [Koibuchi and Chin 2000](#)). HBCD specifically has been shown to interfere with thyroid hormone-mediated neurogenesis and differentiation, calcium homeostasis, and neurotransmitter reuptake. Normal neurodevelopment is dependent on tight regulation of all of these systems and perturbations are associated with persistent changes in behavior and neurological function ([Finken et al. 2013](#); [Julvez et al. 2013](#); [Román et al. 2013](#);

[Henrichs et al. 2010](#); [Haddow et al. 1999](#)). See [*Risk Evaluation for Cyclic Aliphatic Bromide Cluster (HBCD), Supplemental Information on Human Health Hazard (U.S. EPA 2019e)*] for more details. Additionally, a recent publication ([Rasinger et al. 2018](#)) identified genomic and proteomic changes in the brain of female mice related to estradiol signaling, cell-cell junctions, endocytosis, and sirtuin signaling. Modulation of these functions could result in dysregulated calcium homeostasis, oxidative stress, and impaired cholesterol/fatty acid metabolism, all of which could result in detrimental neurological effects.

Overall, there is evidence from animal studies to support potential nervous system effects associated with HBCD exposure during development. However, although the data support a qualitative assessment of developmental neurotoxicity, there are notable inconsistencies and/or limitations with the database. Treatment-related effects were observed in all but one study that evaluated the effects of developmental exposure on nervous system function, but there was no consistent pattern of effect across studies. Furthermore, study quality issues (*i.e.*, lack of blinding, health issues in the animals, pooling of data, failure to measure potential confounders, wide variation in response, and questions regarding the statistical methodology) were identified in several studies. In light of these uncertainties, selection of data sets from the available developmental neurotoxicity studies for dose-response analysis was not supported.

Adult Exposure

Neurotoxicity following HBCD exposure during adulthood was not supported by observations in animal studies ([Genskow et al. 2015](#); [van der Ven et al. 2006](#); [WIL Research 2001, 1997](#)). Adult male mice exposed to 25 mg/kg-day for 30 days showed decreased striatal levels of dopamine transporter and vesicular monoamine transporter 2, regulators of dopamine homeostasis and neurotransmission ([Genskow et al. 2015](#)). Similarly, an *in vitro* study found a dose-related reduction in dopamine and gamma-aminobutyric acid uptake in rat synaptosomes and vesicles exposed to HBCD ([Mariussen and Fonnum 2003](#)). Although prolonged deficits in reuptake mechanisms could result in excessive stimulation of the post synaptic cell or deplete neurotransmitter stores in the presynaptic cell, ([Genskow et al. 2015](#)) did not find significant changes in tissue concentrations of dopamine or its metabolites in adult mice exposed for 30 days. Therefore, this hazard was not carried forward for dose-response analysis.

3.2.4.1.6 Immune System Effects

The potential immunotoxicity of HBCD has not been investigated in human populations. The effects of HBCD on both functional and structural immune endpoints were evaluated in animal models. Of the endpoints evaluated, measures of T cell-dependent antibody responses—functional immune endpoints and therefore more sensitive and predictive indicators of potential immunotoxicity ([Luster et al. 2005](#))—were given more weight.

Developmental Exposure

In studies in rats, early-life HBCD exposure altered antibody responses to sheep red blood cells (SRBC) (increased) ([van der Ven et al. 2009](#)) and keyhole limpet hemocyanin (KLH) (decreased) ([Hachisuka et al. 2010](#)). Healthy immune function is maintained as a delicate balance between: (1) an immune response adequate to provide protection from certain types of cancers and infectious diseases, and (2) pathological loss of immune system control resulting in conditions such as autoimmunity, hypersensitivity, and chronic inflammation. Unintended immunomodulation in either direction (*i.e.*, immunosuppression or immunostimulation) may be considered adverse ([WHO 2012](#)). Therefore, the difference in direction of effect in the only two measures of antibody response does not necessarily minimize the validity of the findings in early life stage animals. These antibody responses were not

adequately supported by consistent observational endpoints. Specifically, a statistically significant decrease in thymus and spleen weight was observed in the F2 generation of ([Ema et al. 2008](#)) but not in any other study.

Adult Exposure

HBCD did not cause changes in functional immune endpoints in adult rats or mice ([Watanabe et al. 2010](#); [van der Ven et al. 2006](#)). The database does not provide a clear and consistent pattern of effect on immune organ weights, hematology, or histopathology following adult exposure. Given the diversity of study designs, exposure conditions, and analytical methods represented in this database, it is difficult to identify the underlying reasons for the differences in observations across studies.

Mechanistic Evidence

Mechanistic data suggests that HBCD stimulates pro-inflammatory cytokines, however some of these responses are not consistently observed. HBCD may stimulate an immune response by increasing the activity of antigen-presenting cells ([Koike et al., 2016](#)) and appears to alter human natural killer (NK) cell function *in vitro* ([Hinkson and Whalen 2010, 2009](#)). See [*Risk Evaluation for Cyclic Aliphatic Bromide Cluster (HBCD), Supplemental Information on Human Health Hazard* ([U.S. EPA 2019e](#))] for more details.

Overall, while there is some evidence to support immune system effects following HBCD exposure (at least for early-life exposure), the data are limited and inconsistent. Therefore, the WOE is inconclusive and this hazard was not carried forward for dose-response analysis.

3.2.4.1.7 Overt Toxicity Following Acute/Short Term Exposures

Studies examining the toxicity of HBCD in humans following acute exposures have not been identified. There is limited evidence from acute toxicity studies in both rodents and rabbits exposed to high levels of HBCD for some minor and reversible neurological effects (*e.g.*, ptosis (upper eyelid drooping), apathy, trembling, and hypoactivity) via the oral route, and mortality via the oral, dermal, and inhalation routes. Mortality or clinical signs of toxicity were not observed in rats following inhalation exposure to 2000 mg/m³ HBCD administered 6h/day for 14 days ([Song et al. 2016](#)). While this study conflicts with data from repeat-dose oral studies, the study is too short of a duration to examine any chronic effects. Additionally, the study did not examine the critical effects of thyroid hormone regulation or any reproductive/developmental outcomes.

Evidence for overt toxicity or mortality at toxicologically relevant doses is not supported by the available data from high dose acute exposure studies. Additionally, since these shorter-term oral exposure studies were either acute lethality studies or studies involving only single doses, they were not considered amenable to quantitative analysis. Therefore, this hazard was not carried forward for dose-response analysis.

3.2.4.1.8 Sensitization/Irritation

No studies have been identified examining the irritation or sensitization potential of HBCD in humans. A few studies in animals have found evidence for sensitizing potential of HBCD ([Canbaz et al. 2016a](#); [Momma et al. 1993](#)) and HBCD stimulated release of pro-inflammatory cytokines, however, dermal sensitization has not been consistently observed ([NRC 2000b](#); [Microbiological Associates 1996b](#)). Overall, there is insufficient evidence of irritation and inconsistent data regarding skin sensitization from HBCD exposure. In addition, there is only qualitative information available on these hazards. Therefore, they were not carried forward for dose-response analysis.

3.2.4.2 Genotoxicity/Carcinogenicity

Overall, given the limited data and mixed results between mammalian and non-mammalian systems, there is indeterminate evidence to make a conclusion on the genotoxicity of HBCD.

The only experimental animal study to examine cancer endpoints concluded that HBCD was not carcinogenic, however, this study was only available as an incomplete report ([Kurokawa et al. 1984](#)). Therefore, according to the U.S. EPA Guidelines for Carcinogen Risk Assessment ([U.S. EPA 2005](#)), there is “inadequate information to assess the carcinogenic potential” of HBCD. Despite the limited evidence, it is unlikely that the results of any potential additional studies would significantly alter the conclusions about the hazard due to the mixed results and the negative incomplete report. As a result, this hazard was not carried forward for dose-response analysis.

3.2.4.3 Summary of Human Health Hazards Used to Evaluate Acute and Chronic Exposures

The EPA considered adverse effects for HBCD across organ systems. A comprehensive systematic review table can be found [*Risk Evaluation for Cyclic Aliphatic Bromide Cluster (HBCD), Systematic Review Supplemental File: Data Quality Evaluation of Human Health Hazard Studies* ([U.S. EPA 2019n](#))]. The full list of human health effects was screened to those that are relevant, sensitive, and found in multiple studies. The HBCD human health hazard systematic review process screened 1,890 studies and obtained 53 studies that were relevant and applicable to the PECO statement. Only two of these studies were unacceptable based on data evaluation criteria. The remaining database of 51 studies included epidemiological studies that examined associations between HBCD exposure and endpoints related to effects on the thyroid, nervous system, and female reproductive system as well as repeat-dose experimental animal studies examining dose-responses for the endpoints of thyroid effects, liver effects, male and female reproductive effects, developmental toxicity, neurotoxicity, and immunotoxicity. EPA additionally considered data on toxicity following acute exposures, irritation, sensitization, genotoxicity, and carcinogenicity. From these effects, the EPA selected endpoints supported by the weight of the scientific evidence for non-cancer adverse outcomes that were amenable to quantitative analysis for dose-response assessment as discussed in more detail below in Section 3.2.5. In the following sections, the EPA identifies the appropriate toxicological studies to be used for acute and chronic exposure scenarios.

3.2.5 Dose-Response Assessment

3.2.5.1 Selection of Studies for Non-Cancer Dose-Response Assessment

As discussed in Section 3.2.4, studies in humans were not adequate to support conclusions regarding the relationship between HBCD exposure and effects on the thyroid, male reproduction, or nervous system, and accordingly do not support dose-response analysis. In the absence of adequate human data, animal toxicity studies were used for dose-response analysis.

The EPA evaluated data from studies described above (Section 3.2.3.1) to characterize the dose-response relationships of HBCD and selected studies and endpoints to quantify risks for specific exposure scenarios. One of the additional considerations was that the selected key studies had adequate information to perform dose-response analysis for the selected Points of Departure (PODs). A POD can be the 95% lower bound of the benchmark dose (BMDL) for an estimated incidence based on a designated change in response level (BMR) or a NOAEL/LOAEL for an observed incidence or change in the level of response.

Based on the WOE evaluation, four health effect domains were selected for non-cancer dose-response analysis: (1) thyroid; (2) liver; (3) female reproductive; and (4) developmental. These hazards have been carried forward for dose-response analysis. While there is also evidence to support nervous system toxicity following exposure to HBCD during development (and this is a likely downstream outcome of thyroid hormone deficiency), these data sets were insufficiently robust to support dose-response analysis. Data sets for male reproductive effects, adult neurological effects, immune system effects, genotoxicity, and cancer were also not carried forward for dose-response analysis. For a complete discussion, see Section 3.2.4.

Studies that evaluated each of the four health effect domains were identified in Section 3.2.3, and are considered in this section for dose-response analysis. In order to identify studies for dose-response analysis, several attributes of the studies were reviewed. Preference was given to studies using designs reasonably expected to detect a dose-related response. Chronic or subchronic studies are generally preferred over studies of less-than-subchronic duration for deriving chronic and subchronic reference values. Studies with a broad exposure range and multiple exposure levels are preferred to the extent that they can provide information about the shape of the exposure-response relationship. Additionally, studies that can reliably measure the magnitude and/or degree of severity of the effect are preferred.

Experimental animal studies considered for each hazard and effect were evaluated using systematic review study quality considerations discussed in the Systematic Review Methods section. Only studies that scored an acceptable rating in data evaluation were considered for use in dose-response assessment. For HBCD, all evaluated repeated-dose studies that were considered acceptable received a medium or high rating in data evaluation (*Risk Evaluation for Cyclic Aliphatic Bromide Cluster (HBCD), Systematic Review Supplemental File: Data Quality Evaluation of Human Health Hazard Studies* ([U.S. EPA 2019n](#))). In addition to the data quality score, considerations for choosing from among these studies included study duration, relevance of study design, and the strength of the toxicological response. Details on these considerations for each endpoint are provided below. For all endpoints other than liver toxicity, ([Ema et al. 2008](#)) was considered the best study for dose-response assessment. The study was an OECD Guideline 2-generation reproductive toxicity study and scored a high in data evaluation. The 90-day repeat-dose oral study ([WIL Research 2001](#)) also scored a high and was additionally considered for use in dose-response assessment only for the liver toxicity endpoint. See Section 3.2.5.2 for a more detailed explanation of EPA's basis for selection of these studies and derivation of PODs for each endpoint.

Given the different HBCD exposures scenarios considered (both acute and chronic), different endpoints were used based on the expected exposure durations. For non-cancer effects and based on a WOE analysis of toxicity studies from rats, risks for developmental effects including developmental disruption of thyroid hormone homeostasis that may result from a single exposure were evaluated for both acute (short-term) exposures and chronic (long-term, repeated/continuous) exposures, whereas risks for other adverse effects (*e.g.*, thyroid toxicity, liver toxicity, and female reproductive toxicity) were evaluated only for chronic exposures to HBCD. Although developmental studies typically involve multiple exposures, these studies are considered relevant for evaluating single exposures when the adverse effect may plausibly result from a single exposure during a critical window of development ([Davis et al. 2009](#); [Van Raaij et al. 2003b](#)). This is consistent with EPA's Guidelines for Reproductive Toxicity Risk Assessment ([U.S. EPA 1996](#)) and Guidelines for Developmental Toxicity Risk Assessment ([U.S. EPA 1991](#)), which state that repeated exposure is not a necessary prerequisite for the manifestation of developmental toxicity.

While there is uncertainty whether postnatal effects such as neonatal pup loss and decreased body weight can result from single developmental exposures, there is increased risk following acute exposures for HBCD, which is a persistent and bioaccumulative toxicological agent with a long half-life. Unlike many other chemicals with short half-lives (on the order of hours or less), HBCD has a derived elimination half-life as high as 64 days in humans ([Geyer et al. 2004](#)), indicating that even a single exposure may result in a retained body burden for an extended period of time. Consequently, in this Risk Evaluation EPA concluded that single or acute exposures to HBCD could result in detrimental and potentially irreversible effects on postnatal growth and viability, while acknowledging that risk for these endpoints is dependent on the specific timing of exposure. There is strong evidence that HBCD can reduce thyroid hormone levels in pregnant rats ([Ema et al. 2008](#)) and evidence from other thyroid disruptors suggests that acute or short-term exposure can result in thyroid hormone effects ([Paul et al. 2010](#); [Hedge et al. 2009](#); [Zhou et al. 2001](#)), including in weanlings. These changes would presumably result in downstream effects on developmental endpoints ([Forhead and Fowden 2014](#); [Gilbert and Zoeller 2010](#); [Hulbert 2000](#)). Using the developmental endpoints as acute PODs is a health protective approach as it takes the results from a chronic two-generation study, where exposures lasted throughout pregnancy of the animal through weaning and sexual maturity. EPA also assumes that a single acute exposure could lead to the same effects if that exposure occurs during a critical window within the pregnancy term. Nonetheless, this approach has a biologically supported basis.

3.2.5.2 Derivation of Points of Departure and Uncertainty Factors

A set of dose-response models were applied to empirically model the dose-response relationship in the range of the observed data. The models in EPA's Benchmark Dose Software (BMDS, version 2.6) were applied. Consistent with EPA's *Benchmark Dose Technical Guidance Document* ([U.S. EPA 2012a](#)), the benchmark dose (BMD) and 95% lower confidence limit on the BMD (BMDL) were estimated using a benchmark response (BMR) to represent a minimal, biologically significant level of change, when possible. The BMR is represented by a specified amount of change, or relative deviation (RD), for continuous data. The BMR for dichotomous data is represented by a specified incidence, or extra risk (ER). In the absence of information regarding the level of change that was considered biologically significant, a BMR of 1 standard deviation (SD) from the control mean for continuous data or a BMR of 10% ER for dichotomous data was used to estimate the BMD and BMDL, and to facilitate a consistent basis of comparison across endpoints, studies, and assessments. Endpoint-specific BMRs are described further below. Where modeling was feasible, the estimated BMDLs were used as points of departure (PODs); the PODs are summarized in Table 3-9. Further details, including the modeling output and graphical results for the model selected for each endpoint, can be found in Appendix I and [Risk Evaluation for Cyclic Aliphatic Bromide Cluster (HBCD), *Supplemental Information on Human Health Hazard* ([U.S. EPA 2019e](#))]. Where dose-response modeling was not feasible, NOAELs or LOAELs were also identified and are summarized.

Selecting the model to use for POD computation

The following approach is recommended for selecting the model(s) to use for computing the BMDL to serve as the POD for a specific dataset according to EPA Benchmark Dose Guidance ([U.S. EPA 2012a](#)). This guidance was followed for HBCD BMD modeling analysis.

- a) Assess goodness-of-fit, using a value of $\alpha = 0.1$ to determine a critical value (or $\alpha = 0.05$ or $\alpha = 0.01$) if there is reason to use a specific model(s) rather than fitting a suite of models.
- b) Further reject models that apparently do not adequately describe the relevant low- dose portion of the dose-response relationship, examining residuals and graphs of models and data.

- c) As the remaining models have met the recommended default statistical criteria for adequacy and visually fit the data, any of them theoretically could be used for determining the BMDL. The remaining criteria for selecting the BMDL are necessarily somewhat arbitrary and are suggested as defaults.
- d) If the BMDL estimates from the remaining models are sufficiently close (given the needs of the assessment), reflecting no particular influence of the individual models, then the model with the lowest AIC may be used to calculate the BMDL for the POD. This criterion is intended to help arrive at a single BMDL value in an objective, reproducible manner. If two or more models share the lowest AIC, the simple average or geometric mean of the BMDLs with the lowest AIC may be used. Note that this is not the same as “model averaging”, which involves weighing a fuller set of adequately fitting models. In addition, such an average has drawbacks, including the fact that it is not a 95% lower bound (on the average BMD); it is just the average of the particular BMDLs under consideration (*i.e.*, the average loses the statistical properties of the individual estimates).
- e) If the BMDL estimates from the remaining models are not sufficiently close, some model dependence of the estimate can be assumed. Expert statistical judgment may help at this point to judge whether model uncertainty is too great to rely on some or all of the results. If the range of results is judged to be reasonable, there is no clear remaining biological or statistical basis on which to choose among them, and the lowest BMDL may be selected as a reasonable conservative estimate. Additional analysis and discussion might include consideration of additional models, the examination of the parameter values for the models used, or an evaluation of the BMDs to determine if the same pattern exists as for the BMDLs. Discussion of the decision procedure should always be provided.
- f) In some cases, modeling attempts may not yield useful results. When this occurs and the most biologically relevant effect is from a study considered adequate but not amenable to modeling, the NOAEL (or LOAEL) could be used as the POD. The modeling issues that arose should be discussed in the assessment, along with the impacts of any related data limitations on the results from the alternate NOAEL/LOAEL approach.

3.2.5.2.1 PODs for Acute Exposure

Developmental Effects

Acute exposure in humans is defined for occupational settings as exposure over the course of a single 8-hour work shift and for the general population as a single 24-hour day. Consistent with EPA’s Guidelines for Reproductive Toxicity Risk Assessment, as discussed in Section 3.2.5.1, developmental toxicity is considered relevant for calculating risks associated with acute occupational or general population exposure.

Reduced offspring viability is a sensitive endpoint that is considered a marker for developmental toxicity. A single study reported reductions in postnatal offspring viability ([Ema et al. 2008](#)) and was judged to support dose-response analysis of viability as a measure of developmental effects.

Reduced offspring body weight is a sensitive endpoint that is considered a marker for fetal growth restriction. Decreased pup body weight was reported in four studies ([Maranghi et al. 2013](#); [Saegusa et al. 2009](#); [van der Ven et al. 2009](#); [Ema et al. 2008](#)). ([Maranghi et al., 2013](#)) only used a single dose level. Observed effects were not consistently dose-responsive in ([van der Ven et al. 2009](#)). Additionally, the magnitude of decreased pup body weight reported by ([Ema et al. 2008](#)) was substantially greater than ([Saegusa et al. 2009](#)). Finally, ([Ema et al. 2008](#)) examined a larger number of animals per group than

other studies and covered a broader dose range than all other studies except ([Saegusa et al. 2009](#)). For the above reasons, ([Ema et al. 2008](#)) was selected for dose-response analysis of pup body weight as a measure of developmental effects following acute exposures. Table 3-6 summarizes study design features considered in evaluating the strength of each study that reported changes in pup weight for purpose of dose-response analysis.

Delayed eye opening is a marker of disrupted developmental maturation. A consistent dose-responsive increase in delayed opening (based on reductions in eye opening at PND 14) was observed in both male and female F2 offspring (F1 data was inconsistent) in ([Ema et al. 2008](#)). Therefore, this study was judged to also support dose-response analysis of delayed opening as a measure of developmental effects.

Table 3-6. Study Design Features of Developmental Toxicity Studies

Study reference	Route	Exposure duration	Number of dose groups ^a	Number of animals/ group	Dose range (mg/kg-d)	Data Quality
(Ema et al. 2008)	Diet	Two-generation	3	13–24 rat litters	10–1,570 ^b	High (1.0)
(van der Ven et al. 2009)	Diet	One-generation	7	≥14 rats	0.1–100	High (1.2)
(Saegusa et al. 2009)	Diet	Gestation and lactation (~42 d)	3	10–14 rats/sex ^c	15–1,505	High (1.2)
(Maranghi et al. 2013)	Diet	28 days	1	10–15 female mice	199	High (1.3)

^aExcludes the control group.
^bDoses differed by sex and generation (see, for example, Table 1-4).
^cFor PND 0 data, exact number of animals examined per dose group was unclear based on the published study.

In a study by ([van Raaij et al. 2003a](#)) a comparison between repeated and single dose studies across a range of chemicals showed that the NOAELs and LOAELs for fetal body weight were 2-4 fold lower than those for single-dose studies, thereby indicating that fetal body weight is more sensitive to repeated exposures. Body weight reduction in pups is therefore generally most applicable to estimating risks for chronic exposures (at least for short half-life chemicals). Nonetheless, there remains uncertainty regarding the applicability of the limited dataset examined in ([van Raaij et al. 2003a](#)) to persistent chemicals with long half-lives such as HBCD. It is uncertain whether the dose-duration relationships identified in ([van Raaij et al. 2003a](#)) for fetal body weight are also applicable to postnatal effects observed following HBCD exposure. While offspring loss was only observed in the F2 generation ([Ema et al. 2008](#)), suggesting a multigenerational effect (possibly due to increasing bioaccumulation) over repeated exposures, the data does not exclude the possibility of this effect occurring following acute exposures during a critical window of development. As discussed in Section 3.2.3.1, evidence from other thyroid disruptors suggests that acute or short-term exposure can result in thyroid hormone effects ([Paul et al. 2010](#); [Hedge et al. 2009](#); [Zhou et al. 2001](#)), including in weanlings, and these hormonal changes could result in downstream effects on developmental endpoints ([Forhead and Fowden 2014](#); [Gilbert and Zoeller 2010](#); [Hulbert 2000](#)). Additionally, due to HBCD's long half-life a single exposure results in a chronic internal dose. Therefore, in order to be health protective given the persistence of HBCD in the body and the absence of any other usable PODs from other potential acute endpoints (such as neurotoxicity) for considering acute exposure scenarios, EPA considered the developmental endpoints

of F2 offspring loss, reduced F2 pup body weight, and delayed eye opening as the basis for the dose-response analysis for acute exposures to HBCD.

Offspring Loss

Increased offspring loss in the F2 generation from the ([Ema et al. 2008](#)) study was amenable to BMD nested modeling, using individual animal data obtained from the study authors (personal communication, ([Makris 2016](#)) with implantation size (number) use as a covariate. Two datasets were modeled: offspring loss (indicating decreased offspring viability) from implantation through PND 4 and offspring loss from PND 4 (post-culling) through PND 21. Maternal gestational doses (10, 100, and 995 mg/kg-day) were used to model offspring loss from the implantation through PND 4 dataset and modeling for the PND 4 post-culling through PND 21 dataset was performed using the maternal lactational doses (20, 179 and 1,724 mg/kg-day).

From a statistical standpoint, most reproductive and developmental studies with nested study designs typically support a BMR of 5% extra risk (ER) ([U.S. EPA 2012a](#)). A smaller BMR of 1% ER was used in this case to address the severity of this endpoint (*i.e.*, offspring loss), in accordance with EPA Benchmark Dose Guidance ([U.S. EPA 2012a](#)), which supports use of smaller BMRs for more severe or “frank” effects. The use of a 1% ER is justified for mortality, because death is clearly not a reasonable risk for any percentage of the population. For purposes of comparison, a POD based on the NOAEL is presented in addition to the BMDL₀₁ (see Section 3.2.5.3). The NCTR/Rai and Van Ryzin model was used for offspring loss from implantation through PND 4 based on selection of the lowest BMDL (see step 5 in BMD guidance), and the NLogistic model with intra-litter correlation but without the covariate was used for PND 4 through PND 21 loss based on selection of the lowest AIC (see step 4 in BMD guidance).

Pup body weight

Changes in F2 pup body weight as reported in the two-generation reproductive toxicity study by ([Ema et al. 2008](#)) were amenable to BMD modeling. A BMR of 5% RD from control mean was applied in modeling pup body weight changes under the assumption that it represents a minimal biologically significant response. In adults, a 10% decrease in body weight in animals is generally recognized as a biologically significant response associated with identifying a maximum tolerated dose; during development, however, identification of a smaller (5%) decrease in body weight is consistent with the assumptions that development represents a susceptible lifestage and that the developing animal is more adversely affected by a decrease in body weight than the adult. In humans, reduced birth weight is associated with numerous adverse health outcomes, including increased risk of infant mortality as well as heart disease and type II diabetes in adults ([Barker 2007](#); [Reyes and Mañalich 2005](#)). The selection of a 5% BMR is additionally supported by data from ([Kavlock et al. 1995](#)) which found that a BMR of 5% RD for fetal weight reduction was statistically similar to several other BMR measurements as well as to statistically-derived NOAEL values, however EPA acknowledges the uncertainty in extrapolating this fetal data to postnatal effects. For these reasons, a BMR of 5% RD was selected for decreased pup weight. The exponential (M4) model was used for male weanlings based on lowest BMDL (see step 5 in BMD guidance) and the linear model was used for female weanlings based on lowest AIC (see step 4 in BMD guidance).

Delayed eye opening

Delayed eye opening data in both male and female offspring of the F2 generation from the ([Ema et al. 2008](#)) study were amenable to BMD nested modeling, using individual animal data obtained from the study authors (personal communication) ([Jacobs 2019](#)). Calculated F2 offspring doses (15, 139 and 1360

mg/kg-day) were used to model delayed eye opening. Modeling was performed using the most recent version of BMDs (v 3.1.1). The only model included in the software for use with nested data is the nested logistic model. The NCTR model from earlier BMDs versions is scheduled for addition to the software at some point in the future. The Rai and Van Ryzin model from earlier BMDs versions is no longer supported. Significant model fit was achieved with intra-litter correlation included, and the selected covariate of number of implantations did not make a significant difference on model fit. The male dataset reflected very high levels of uncertainty based on a BMD/BMDL ratio of 16-31, so the resulting BMDL was not selected as a POD and instead the NOAEL was used. The female dataset resulted in a BMD/BMDL ratio of only ~2.6, and visual inspection of model fit along with review of scaled residuals confirmed adequate model fit. A BMR of 5% extra risk was selected for similar reasons stated above for pup body weight, because delayed eye opening is a sensitive marker of potentially irreversible broader physiological and/or neuromuscular developmental outcomes. The nested logistic model with intra-litter correlation but without the covariate was selected based on selection of the lowest AIC (see step 4 in BMD guidance). See Appendix I.1.4 for BMD modeling results of all developmental endpoints.

Thyroid hormone effects

As discussed above, evidence from other thyroid disruptors suggests that acute or short-term exposure can result in thyroid hormone effects ([Paul et al. 2010](#); [Hedge et al. 2009](#); [Zhou et al. 2001](#)), and these hormonal changes could result in downstream effects on developmental endpoints ([Forhead and Fowden 2014](#); [Gilbert and Zoeller 2010](#); [Hulbert 2000](#)). A recent study ([O'Shaughnessy et al. 2019](#)) demonstrated that hypothyroidism over only a 5-day gestational/post-natal window is sufficient to cause cortical heterotopia in rat offspring, a permanent brain malformation that is associated with epilepsy and learning disabilities in humans. Therefore, thyroid hormone changes in dams from chronic studies were considered as adverse for acute exposure scenarios in a developmental context. As described in Section 3.2.4.1.1, while there are some significant differences in the thyroid system between rodent and human adults, gestational HBCD exposure is likely to result in quantitatively similar developmental outcomes. Additionally, because rats are more altricial than humans, thyroid maturation (and thyroid hormone-associated growth and development) proceeds later in rats than humans. Consequently, human offspring may be more susceptible *in utero* to many developmental outcomes that were observed only postnatally in rats (e.g., mortality, reduced body weight).

Changes in maternal serum thyroxine (T4) was selected as the endpoint representative of thyroid effects. See the full discussion of study selection and BMD modeling considerations for this endpoint in Section 3.2.5.2.2 below. In short, T4 data sets from ([Ema et al. 2008](#)) were selected for dose-response analysis. Only data from female rats was considered for acute exposure scenarios, since gestational effects are of primary concern. A BMR of 10% RD from control means, supported by the literature on the effects of thyroid insufficiency in pregnant females and their offspring, was applied in modeling the female T4 data. The exponential (M4) model was selected for derivation of all BMDLs for the thyroid endpoint based on lowest BMDL for females (step 5 in BMD guidance). Further discussion is provided below in Section 3.2.5.2.2. See Appendix I.1.1 for all BMD modeling results on the T4 dataset.

3.2.5.2.2 PODs for Chronic Exposures

Chronic exposure was defined for occupational settings as exposure reflecting a 40-hour work week at 8 hrs/day. Chronic exposure to the general population represents exposure averaged over 24 hours/day, 365 days/year, for the number of years living near a facility (either 13 or 33 years). Non-cancer endpoints selected as most relevant for calculating risks associated with chronic (repeated) occupational exposures to HBCD included toxicity to the thyroid, liver, female reproductive, and developmental effects.

Table 3-12 summarizes the hazard studies and health endpoints by target organ/system that the EPA considered suitable for the Risk Evaluation of chronic exposure scenarios for HBCD. Key studies in Table 3-12 are briefly described in Non-Cancer Hazards, Section 3.2.3.1, along with other toxicity and epidemiological studies. BMD modeling was performed for these endpoints in a manner consistent with EPA Benchmark Dose Technical Guidance. BMR was selected for each endpoint.

Thyroid hormone effects

Changes in serum thyroxine (T4) was selected as the endpoint representative of thyroid effects based on the following: (1) changes in T4 were observed in multiple studies; (2) T4 is likely to be the primary driver of HBCD-mediated thyroid effects; and (3) it is well established that perturbations in T4 are associated with biologically significant health effects. Specifically, adequate levels of T4 are necessary for normal growth and development, and altered thyroid homeostasis has the potential to affect numerous organ systems, including neuronal, reproductive, hepatic, and immune systems ([Forhead and Fowden 2014](#); [Gilbert and Zoeller 2010](#); [Hulbert 2000](#)). Additionally, reductions in maternal T4 during pregnancy or the early postnatal period are strongly associated with adverse neurological outcomes in offspring. In humans, mild to moderate maternal thyroid insufficiency is associated with higher risk for persistent cognitive and behavioral deficits in children (see below).

Based on considerations of study design and magnitude of T4 response, T4 data sets from ([Ema et al. 2008](#)) were selected for dose-response analysis. The 2-generation study design used by ([Ema et al. 2008](#)) involved a longer exposure duration and larger group size than ([van der Ven et al. 2006](#)), while inadequate reporting of thyroid hormone measurement methods, small sample sizes, and questionable control data reduced the confidence in the thyroid hormone results from ([WIL Research 2001](#)). Table 3-7 provides an overview of the study designs for those studies reporting T4 levels that were evaluated for dose-response analysis of thyroid effects.

Table 3-7. Study Design Features of Studies that Examined T4 Levels

Study reference	Route	Exposure duration	Number of dose groups ^a	Number of animals/group	Dose range (mg/kg-d)	Data Quality
(Ema et al. 2008)	Diet	Two-generation	3	8 rats/sex	10–1,363 ^a	High (1.0)
(WIL Research 2001)	Gavage	90 days	3	5–10 rats/sex	100–1,000	Low* (3)
(van der Ven et al. 2006)	Gavage	28 days	7	4–5 rats/sex	0.3–200	High (1.3)

^aDoses differed by sex and generation
 *This study received a calculated score of 1.3 but was manually downgraded to Low for thyroid outcomes.

Specifically, T4 data from F0 male and female rats and from F1 female rats in ([Ema et al. 2008](#)) were used for quantitative analysis. Because the magnitude of response in F1 male rats was smaller than the response in these generations (by one-third to one-half), T4 data from F1 male rats was not modeled. Based on the data observed in both humans and animals demonstrating downstream health effects associated with a reduction of 10% and above in maternal T4 levels ([Gilbert et al. 2014](#); [Gilbert et al. 2013](#); [Gilbert 2011](#); [Liu et al. 2010](#); [Ausó et al. 2004](#)), a BMR of 10% RD from control mean was

determined to be a minimally biologically significant degree of change when performing BMD modeling using female rat data. Additionally, one study ([Gilbert et al. 2016](#)) demonstrated that mild T4 (<20%) reduction in dams can become amplified in offspring (>45%), resulting in long-lasting reductions in neurotrophin gene expression leading to learning deficits. The available thyroid literature does not support identification of a biologically significant change in T4 levels in adult males as decreases in T4, and more generally thyroid function, have not been conclusively linked to similarly severe outcomes as in females. Nevertheless, males with depressed T4 values are part of the subpopulation that experiences thyroid dysfunction and there is no evidence to suggest that they are consistently more sensitive to T4 changes than females. Consistent with EPA's *Benchmark Dose Technical Guidance Document* ([U.S. EPA 2012a](#)), a BMR of one control SD change from the control mean was applied in modeling T4 data from male rats in the absence of a biological basis for selecting a BMR. Additionally, a BMR of 10% RD from control means, supported by the literature on the effects of thyroid insufficiency in pregnant females and their offspring, was also applied in modeling the male T4 data. Under the assumption that differences in thyroid hormone response in male and female rats exposed to HBCD are not sex-specific but rather a reflection of hormone variability, using a BMR of 10% RD was also considered appropriate for this dataset. The exponential (M4) model was selected for derivation of all BMDLs for the thyroid endpoint (based on lowest AIC for males [step 4 in BMD guidance] and based on lowest BMDL for females [step 5 in BMD guidance]). See Appendix I.1.1 for all BMD modeling results on the T4 dataset.

Liver Effects

Although increased liver weight is not adverse on its own, it serves as an effective and sensitive quantitative indicator for liver toxicity when associated with other toxicological indicators, especially within a potentially susceptible population. Evidence suggests that HBCD exposure impairs hepatic lipid homeostasis, potentially through the production of ROS (Section 3.2.4.1.2), however establishing a dose-response and adverse threshold for these indicators is difficult. Increased liver weight was therefore selected as the representative endpoint for dose-response analysis of liver effects based on being the most consistently observed toxicological effect. Increased liver weight was reported in six studies in rats ([Saegusa et al. 2009](#); [Ema et al. 2008](#); [van der Ven et al. 2006](#); [WIL Research 2001, 1997](#)) and mice ([Maranghi et al. 2013](#)). Increased liver weight was also accompanied by increased hepatocellular vacuolization in ([Maranghi et al. 2013](#); [Saegusa et al. 2009](#); [WIL Research 2001, 1997](#)), hypertrophy in ([WIL Research 1997](#)), and inflammation in ([Maranghi et al. 2013](#)).

([Ema et al. 2008](#)) consistently observed increased liver weights in rats across multiple generations (*i.e.*, F0, F1, and F2), lifestages (*i.e.*, postnatal day [PND] 26 offspring and adults), and in both sexes, particularly at the high dose. Elevated liver weight was also observed along with hepatocellular vacuolization in both sexes of rats across all dose groups in a 90-day study by ([WIL Research 2001](#)). This study also observed statistically-significant elevated serum gamma-glutamyl transferase (GGT) and a dose-responsive (non-statistically significant) increase in alanine aminotransferase (ALT), indicators of liver damage, at the highest dose. Both studies were selected for dose-response analysis because they provided robust dose-related responses that were consistent across sex and generations (for ([Ema et al. 2008](#)), unlike ([Saegusa et al. 2009](#))) and following longer exposure durations than other studies. Table 3-8 provides an overview of the study designs for those studies reporting relative liver weight that were evaluated for dose-response analysis.

Table 3-8. Study Design Features of Studies that Examined Liver Weight

Study reference	Route	Exposure duration	Number of dose groups ^a	Number of animals/ group	Dose range (mg/kg-d)	Data Quality
(Ema et al. 2008)	Diet	Two-generation	3	13–24 rats/sex	10–1,570 ^a	High (1.0)
(WIL Research 2001)	Gavage	90 days	3	10 rats/sex	100–1,000	High (1.0)
(van der Ven et al. 2006)	Gavage	28 days	7	4–5 rats/sex	0.3–200	High (1.3)
(WIL Research 1997)	Gavage	28 days	3	6 rats/sex	125–1,000	High (1.3)
(Saegusa et al. 2009)	Diet	Gestation and lactation (~42 d)	3	10 rats/sex	15–1,505	High (1.2)
(Maranghi et al. 2013)	Diet	28 days	1	10–15 female mice	199	High (1.3)

^aDoses differed by sex and generation

Liver effects as reported in the [\(Ema et al. 2008\)](#) and [\(WIL Research 2001\)](#) studies were evaluated using BMD modeling. Liver weight data from [\(Ema et al. 2008\)](#) were amenable to modeling. For weanling (PND 26) datasets, the average exposures across gestation and lactation (F1 = 16.5, 168, and 1,570 mg/kg-day; F2 = 14.7, 139, and 1,360 mg/kg-day) were used for modeling because there was no evidence to indicate whether this effect was the result of prenatal exposure, postnatal exposure, or a combination of both. The exponential (M4) model was selected for derivation of all BMDLs for the liver endpoint from [\(Ema et al. 2008\)](#) based on visual fit and lowest AIC (steps 3 and 4 in BMD guidance). The linear model was additionally applied to data from F1 rat adults. A BMR of 10% RD from the control mean was applied in modeling relative liver weight changes under the assumption that it represents a minimal biologically significant change, with liver weight changes considered analogous to the 10% change in body weight that has been used to identify a maximum tolerated dose. Data on liver effects derived from [\(WIL Research 2001\)](#) could not be modeled because none of the models provided adequate fit; therefore, LOAELs were chosen for the PODs derived from these data (step 6 in BMD guidance).

Female Reproductive Effects

Pregnancy incidence and primordial follicle count were selected for dose-response analysis as endpoints representative of female reproductive effects. These effects were reported in a two-generation reproductive toxicity study by [\(Ema et al. 2008\)](#) that included three dose groups in addition to the control. Pregnancy incidence was measured in two generations with exposure durations ranging from approximately 13 weeks (F0) to continuous lifetime exposure (F1); primordial follicle count was only evaluated in the F1 generation. [\(Ema et al. 2008\)](#), the only study to evaluate effects on pregnancy incidence and primordial follicle count, was selected for dose-response analysis of these measures of female reproductive toxicity.

Primordial follicle count

Decreased primordial follicle count as reported in the two-generation reproductive toxicity study by (Ema et al. 2008) was amenable to BMD modeling. Because primordial follicles are formed during gestation, the average dose during this critical window was used for BMD modeling. While there is no consensus regarding the degree of change considered to be adverse, a BMR of 10% RD from control levels was applied in modeling this endpoint under the assumption that it represents a minimal biologically significant effect based on what may be considered a reasonably detectable decrease in follicle number (Heindel 1998). The exponential (M4) model was selected for derivation of all BMDLs for decreased follicle count based on being the only model with adequate fit (step 1 in BMD guidance).

Pregnancy incidence

In the study by (Ema et al. 2008), the increased incidence of non-pregnancy (indicating reduced female fertility index) in HBCD-exposed F0 or F1 rats alone was not statistically significant with either pairwise test (as reported by authors) or Cochran-Armitage trend test (conducted by EPA). Dose-response curves were shallow and never reached a high response percentage. Nevertheless, EPA considered this change to be biologically relevant. To increase statistical power and obtain a more precise estimate of the BMD and BMDL, consideration was given to combining F0 and F1 datasets. Cochran-Mantel-Haenszel statistics on F0 and F1 data stratified by dose groups were not significant ($p = 0.59$, $\alpha = 0.05$), indicating no statistical association between generation and response after adjusting for dose. Equality of responses in F0 and F1 rats was also not rejected ($p > 0.2$, $\alpha = 0.05$) by the Breslow-Day test for homogeneity of the odds ratios, and their background response percentages were not detectably different (Fisher's exact, $p = 1.00$). The results of these statistical tests indicated that F0 and F1 datasets were compatible for combining.

Despite these tests indicating that the datasets were compatible for combining, EPA determined that the F0 and F1 data were not truly independent related datasets. Due to HBCD's bioaccumulation over time, the F1 generation experiences additional continuous exposure compared to F0 animals, and the statistical tests may not account for this confounder. Therefore, the data for increased incidence of non-pregnancy was not considered appropriate for combining, and without statistical significance on either data set alone, the endpoint does not represent a confirmed adverse effect.

Developmental Effects

As described above, developmental effects may result from single as well as repeated exposures at a developmentally critical period; therefore, decreased pup body weight and decreased viability (Ema et al. 2008) were the endpoints selected as most relevant to calculating risks associated with developmental toxicity following chronic as well as acute exposures. A smaller BMR of 1% ER was used in this case to address the severity of this endpoint (*i.e.*, offspring loss). A BMR of 5% RD from control mean was applied in modeling pup body weight changes under the assumption that it represents a minimal biologically significant response.

3.2.5.2.3 Human Equivalent Doses

Human equivalent doses (HEDs) for oral exposures were derived from the PODs according to the hierarchy of approaches outlined in EPA guidance (U.S. EPA 2011c). The preferred approach is physiologically-based pharmacokinetic (PBPK) modeling. Other approaches can include using chemical-specific information in the absence of a complete PBPK model. As discussed in Section 3.2.2, an appropriate toxicokinetic model for HBCD is not available. In the absence of either chemical-specific models or data to inform the derivation of human equivalent oral exposures, body weight scaling to the $3/4$ power (*i.e.*, $BW^{3/4}$) was applied to extrapolate toxicologically equivalent doses of orally administered agents from adult laboratory animals to adult humans.

Consistent with EPA guidance ([U.S. EPA 2011c](#)), the PODs estimated based on effects in adult animals were converted to HEDs employing a standard dosimetric adjustment factor (DAF) derived as follows:

$$DAF = \left(\frac{BW_A}{BW_H} \right)^{0.25}$$

Where

BW_a = animal body weight

BW_h = human body weight

Using BW_a of 0.25 kg for rats and BW_h of 80 kg for humans ([U.S. EPA 2005](#)), the resulting DAF for rats is 0.24. Applying this DAF to the POD_{ADJ} identified for HBCD effects in adult rats, a POD_{HED} was derived as follows:

$$POD_{HED} = \text{Laboratory animal dose (mg/kg-day)} \times DAF$$

BW^{3/4} scaling was not employed for deriving HEDs for increased relative liver weight in pups, offspring loss, or decreased pup weight as reported by ([Ema et al. 2008](#)) where doses were administered to early postnatal animals. There is uncertainty as to whether allometric (*e.g.*, BW^{3/4}) scaling, derived from data in adult animals, holds when extrapolating doses in neonatal animals. This uncertainty arises because of the absence of quantitative information to characterize the toxicokinetic and toxicodynamic differences between animals and humans in early lifestages ([U.S. EPA 2011c](#)).

3.2.5.2.4 Uncertainty Factors

Four areas of uncertainty and variability were considered in benchmark MOE derivation, as summarized below.

A UF for extrapolation from a LOAEL to NOAEL, U_{FL}, of 1 was applied when the POD was based on a BMDL, and the BMR was selected under the assumption that it represented a minimal biologically significant response level. A U_{FL} of 1 was applied to offspring loss where the POD was based on a NOAEL, and a value of 10 was applied to relative liver weight data from ([WIL Research 2001](#)) because the POD was based on a LOAEL.

A subchronic to chronic UF, U_{Fs}, was applied to account for the possibility that longer exposure may induce effects at a lower dose when data are derived from less-than-lifetime exposures. ([Ema et al. 2008](#)) is a multigenerational study where the parental generation is exposed for approximately 15-18 weeks and the offspring are exposed for approximately 21-24 weeks. Given HBCD's propensity to bioaccumulate it is also expected that internal exposure could increase with longer external exposure durations. For thyroid hormone effects, a U_{Fs} of 10 was applied when effects were observed in parental (F0) animals because exposure was subchronic in duration. U_{Fs} was reduced to 1 for PODs for thyroid effects derived from F1 offspring, which have already experienced bioaccumulation across generations following up to 42 weeks of chronic exposure. A U_{Fs} of 1 was also applied to liver weight and both reproductive endpoints from ([Ema et al. 2008](#)), which incorporate data from the F1 generation, for the same reasoning. A U_{Fs} of 3 was applied for liver effects from ([WIL Research 2001](#)), a subchronic 90-day study. U_{Fs} was reduced from 10 to 3 for that endpoint because the feedback interaction between liver metabolism and the HPT axis along with inconsistently observed histopathological or biochemical changes in other studies (see Section 3.2.4.1.2) suggests that there may only be limited adversity with

increasing exposure. For pup weight and offspring loss, which are developmental endpoints, a UF of 1 was applied because the developmental period is recognized as a susceptible lifestage where exposure during certain time windows during development is more relevant to the induction of developmental effects than lifetime exposure ([U.S. EPA 1991](#)).

With the exception of endpoints measured in neonatal animals, a UF for interspecies extrapolation, UF_A , of 3 ($10^{1/2} = 3.16$, rounded to 3) was applied to all PODs because $BW^{3/4}$ scaling was used to extrapolate oral doses from laboratory animals to humans. Although $BW^{3/4}$ scaling addresses some aspects of cross-species extrapolation of toxicokinetic and toxicodynamic processes, some residual uncertainty remains. In the absence of chemical-specific data to quantify this uncertainty, EPA's guidance on $BW^{3/4}$ scaling ([U.S. EPA 2011c](#)) recommends the use of a UF_A of 3. $BW^{3/4}$ scaling was not used to derive HEDs for relative liver weight in weanling rats, decreased pup weight, or offspring loss because of the absence of information on whether allometric (*i.e.*, body weight) scaling holds when extrapolating doses from early postnatal animals to adult humans due to presumed toxicokinetic and/or toxicodynamic differences between lifestages ([U.S. EPA 2011c](#); [Hattis et al. 2004](#)). For these developmental endpoints, interspecies extrapolation was based on administered dose, and an UF_A of 10 was applied to account for the lack of quantitative information to characterize toxicokinetic and toxicodynamic differences between animals and humans at this lifestage.

An intraspecies UF, UF_H , of 10 was applied to account for variability and uncertainty in toxicokinetic and toxicodynamic susceptibility within the subgroups of the human population that are most sensitive to the health hazards of HBCD ([U.S. EPA 2002](#)). In the case of HBCD, the PODs were derived from studies that used an inbred rat strain and that is not considered sufficiently representative of the exposure and dose-response of the most susceptible human subpopulations. In certain cases, the toxicokinetic component of this factor may be replaced when a PBPK model is available that incorporates the best available science on variability in toxicokinetic disposition in the human population (including sensitive subgroups). For HBCD, the available information is insufficient to quantitatively estimate variability in human susceptibility; therefore, the full value for the intraspecies UF was applied.

3.2.5.3 Points of Departure for Human Health Hazard Endpoints

Table 3-9 summarizes the oral PODs (and sequence of adjustments leading to the derivation of a human equivalent POD or POD_{HED}) by target organ/system. As described and justified in Section 3.2.5.2, all of the PODs except for liver toxicity to be used for risk characterization were derived from the two-generation reproductive toxicity study by ([Ema et al. 2008](#)). For liver toxicity, the POD selected for risk characterization was obtained from ([WIL Research 2001](#)), a 90-day oral toxicity study conducted according to OECD testing guidelines.

Table 3-9. Summary of BMD Modeling Results and Derivation of HEDs for HBCD

Endpoint and Reference	Species/ Sex	Model ^a	BMR	BMD (mg/kg-d)	BMDL (mg/kg-d)	POD_{ADJ}^b (mg/kg-d)	POD_{HED}^c (mg/kg-d)
<i>Thyroid</i>							
Decreased T4 (Ema et al. 2008)	F0 rats (Sprague-Dawley)/ male, adults	Exponential (M4)	10% RD	23.9	6.99	6.99	1.68

Endpoint and Reference	Species/ Sex	Model ^a	BMR	BMD (mg/kg-d)	BMDL (mg/kg-d)	POD _{ADJ} ^b (mg/kg-d)	POD _{HED} ^c (mg/kg-d)
Decreased T4 (Ema et al. 2008)	F0 rats (Sprague-Dawley)/ male, adults	Exponential (M4)	1 SD	101	29.5	29.5	7.08
Decreased maternal T4 (Ema et al. 2008)	F0 rats (Sprague-Dawley)/ female, adults	Exponential (M4)	10% RD	334	93.8	93.8	22.5
Decreased maternal T4 (Ema et al. 2008)	F1 rats (Sprague-Dawley)/female, adults	Exponential (M4)	10% RD	448	127	127	30.5
Liver^d							
Relative liver weight (Ema et al. 2008)	F1 rats (CRL)/male weanlings, PND 26	Exponential (M4)	10% RD	163	109	109	109
Relative liver weight (Ema et al. 2008)	F1 rats (CRL)/weanlings, PND 26	Exponential (M4)	10% RD	165	115	115	115
Relative liver weight (Ema et al. 2008)	F1 rats (CRL)/, male, adults	Linear	10% RD	680	573	573	138
Relative liver weight (Ema et al. 2008)	F1 rats (CRL)/, female, adults	Exponential (M4)	10% RD	569	184	184	44.2
Relative liver weight (Ema et al. 2008)	F2 rats (CRL)/, weanlings	Exponential (M4)	10% RD	215	116	116	116
Relative liver weight (Ema et al. 2008)	F2 rats (CRL)/, weanlings	Exponential (M4)	10% RD	286	166	166	166
Relative liver weight and hepatocellular vacuolization (WIL Research 2001)	Rats (Sprague-Dawley)/, male adults	No model fit	LOAEL = 100 (17% RD liver weight, 300% RD vacuolization)			100	24

Endpoint and Reference	Species/ Sex	Model ^a	BMR	BMD (mg/kg-d)	BMDL (mg/kg-d)	POD _{ADJ} ^b (mg/kg-d)	POD _{HED} ^c (mg/kg-d)
Relative liver weight and hepatocellular vacuolization (WIL Research 2001)	Rats (Sprague-Dawley)/, female adults	No model fit	LOAEL = 100 (24% RD liver weight, 200% RD vacuolization)			100	24
Reproductive							
Primordial follicles (Ema et al. 2008)	F1 parental rat (Sprague-Dawley)/, adults	Exponential (M4)	10% RD	10.1	2.87	2.87	0.689
Developmental							
Offspring loss from implantation through PND 4 (Ema et al. 2008)	F2 offspring rats (CRL)/male and female	NCTR/Rai and Van Ryzin	1% ER	109	54.5	54.5	54.5
			5% ER	316	158	158	158
			NOAEL = 100 (-2% ER)			100	100
Offspring loss from PND 4 post-culling through PND 21 (Ema et al. 2008)	F2 offspring rats (CRL)/male and female	NLogistic	1% ER	16.9	9.03	9.03	9.03
			5% ER	88.1	47.1	47.1	47.1
			NOAEL = 19.6 (7% ER)			19.6	19.6
Decreased pup weight (Ema et al. 2008)	F2 rats (CRL)/male weanlings	Exponential (M4)	5% RD	354	89.6	89.6	89.6
Decreased pup weight (Ema et al. 2008)	F2 rats (CRL)/female weanlings	Linear	5% RD	417	297	297	297
Delayed eye opening, F2 rats, female weanlings (Ema et al. 2008)	F2 rats (CRL)/female weanlings	NLogistic	5% ER 10% ER	75.61 159.62	28.73 60.66	28.73 60.66	28.73 60.66
Delayed eye opening, F2 rats, male weanlings	F2 rats (CRL)/male weanlings	NLogistic	NOAEL = 139 mg/kg (25.5% ER)			139	139

Endpoint and Reference	Species/ Sex	Model ^a	BMR	BMD (mg/kg-d)	BMDL (mg/kg-d)	POD _{ADJ} ^b (mg/kg-d)	POD _{HED} ^c (mg/kg-d)
(Ema et al. 2008)							
<p>^a For modeling details, see Appendix I and [Risk Evaluation for Cyclic Aliphatic Bromide Cluster (HBCD), Supplemental Information on Human Health Hazard (U.S. EPA 2019e)].</p> <p>^b All studies involved dietary administration. Therefore, no adjustments to estimate the average daily dose were required, and BMDL, NOAEL, or LOAEL values were equivalent to the POD_{ADJ} in all cases.</p> <p>^c POD_{HED} values for endpoints measured in adult animals were calculated using BW^{3/4} scaling. POD_{HED} values for endpoints measured in neonatal animals were expressed as administered dose.</p> <p>^d Relative liver weight from both (Ema et al. 2008) and (WIL Research 2001) is expressed as g/100 g BW.</p> <p>Note: Both (Ema et al. 2008) and (WIL Research 2001) scored a High in data evaluation.</p>							

Table 3-10 and Table 3-11 are a continuation of Table 3-9, Table 3-10 summarizes the human equivalent PODs and a breakdown of UFs for each relevant endpoint, leading to the derivation of benchmark MOEs for the Risk Evaluation of acute exposure scenarios. Table 3-11 provides the same information for the Risk Evaluation of chronic exposure scenarios.

Table 3-10. PODs and Benchmark MOEs for Effects Following Acute Exposure to HBCD

Endpoint and reference	Developmental exposure window	POD _{HED} ^a (mg/kg-d)	POD type	UF _L	UF _S	UF _A	UF _H	Benchmark MOE
Thyroid								
Decreased maternal T4, F0 rats, female adults (Ema et al. 2008)	Throughout gestation and lactation	22.5	BMDL ₁₀	1	1	3	10	30
Decreased maternal T4, F1 rats, female adults (Ema et al. 2008)	Throughout gestation and lactation	30.5	BMDL ₁₀	1	1	3	10	30
Developmental								
F2 Offspring loss (Ema et al. 2008)	Implantation – PND 4	54.5 158 100	BMDL ₀₁ BMDL ₀₅ NOAEL	1	1	10	10	100
F2 Offspring loss (Ema et al. 2008)	PND 4 – PND 21	9.03 47.1 19.6	BMDL ₀₁ BMDL ₀₅ NOAEL	1	1	10	10	100
Decreased pup weight, F2 rats, male weanlings (Ema et al. 2008)	GD 0 – PND 21	89.6	BMDL ₀₅	1	1	10	10	100

Endpoint and reference	Developmental exposure window	POD _{HED} ^a (mg/kg-d)	POD type	UF _L	UF _S	UF _A	UF _H	Benchmark MOE
Decreased pup weight, F2 rats, female weanlings (Ema et al. 2008)	GD 0 – PND 21	297	BMDL ₀₅	1	1	10	10	100
Delayed eye opening, F2 rats, female weanlings (Ema et al. 2008)	GD 0 – PND 21	28.73 60.66	BMDL₀₅ BMDL ₁₀	1	1	10	10	100
Delayed eye opening, F2 rats, male weanlings (Ema et al. 2008)	GD 0 – PND 21	139	NOAEL	1	1	10	10	100

Table 3-11 PODs and Benchmark MOEs for Effects Following Chronic Exposure to HBCD

Endpoint and reference	POD _{HED} ^a (mg/kg-d)	POD type	UF _L	UF _S	UF _A	UF _H	Benchmark MOE
<i>Thyroid</i>							
Decreased T4, F0 rats, male adults (Ema et al. 2008)	1.68	BMDL ₁₀	1	10	3	10	300
Decreased T4, F0 rats, male adults (Ema et al. 2008)	7.08	BMDL _{1SD}	1	10	3	10	300
Decreased T4, F0 rats, female adults (Ema et al. 2008)	22.5	BMDL ₁₀	1	10	3	10	300
Decreased T4, F1 rats, female adults (Ema et al. 2008)	30.5	BMDL ₁₀	1	1	3	10	30
<i>Liver</i>							
Relative liver weight, F1 rats, male weanlings, PND 26 (Ema et al. 2008)	109	BMDL ₁₀	1	1	10	10	100
Relative liver weight, F1 rats, female weanlings, PND 26 (Ema et al. 2008)	115	BMDL ₁₀	1	1	10	10	100
Relative liver weight, F1 rats, male adults (Ema et al. 2008)	138	BMDL ₁₀	1	1	3	10	30

Endpoint and reference	POD _{HED} ^a (mg/kg-d)	POD type	UF _L	UF _S	UF _A	UF _H	Benchmark MOE
Relative liver weight, F1 rats, female adults (Ema et al. 2008)	44.2	BMDL ₁₀	1	1	3	10	30
Relative liver weight, F2 rats, male weanlings (Ema et al. 2008)	116	BMDL ₁₀	1	1	10	10	100
Relative liver weight, F2 rats, female weanlings (Ema et al. 2008)	166	BMDL ₁₀	1	1	10	10	100
Relative liver weight and hepatocellular vacuolization, rats, male adults (WIL Research 2001)	24	LOAEL	10	3	3	10	1,000
Relative liver weight and hepatocellular vacuolization, rats, female adults (WIL Research 2001)	24	LOAEL	10	3	3	10	1,000
Relative liver weight and hepatocellular vacuolization, rats, female adults (WIL Research 2001)	24	LOAEL	10	3	3	10	1,000
Reproductive							
Primordial follicles, F1 parental rat, female adults (Ema et al. 2008)	0.689	BMDL₁₀	1	1	3	10	30
Developmental							
F2 Offspring loss (Ema et al. 2008); Implantation – PND 4	54.5 158 100	BMDL ₀₁ BMDL ₀₅ NOAEL	1	1	10	10	100
F2 Offspring loss (Ema et al. 2008); PND 4 – PND 21	9.03 47.1 19.6	BMDL₀₁ BMDL₀₅ NOAEL	1	1	10	10	100
Decreased pup weight, F2 rats, male weanlings (Ema et al. 2008); GD 0 – PND 21	89.6	BMDL₀₅	1	1	10	10	100
Decreased pup weight, F2 rats, female weanlings (Ema et al. 2008); GD 0 – PND 21	297	BMDL ₀₅	1	1	10	10	100

Endpoint and reference	POD _{HED} ^a (mg/kg-d)	POD type	UF _L	UF _S	UF _A	UF _H	Benchmark MOE
Delayed eye opening, F2 rats, female weanlings (Ema et al. 2008)	28.73 60.66	BMDL ₀₅ BMDL ₁₀	1	1	10	10	100
Delayed eye opening, F2 rats, male weanlings (Ema et al. 2008)	139	NOAEL	1	1	10	10	100

Table 3-12 lists the POD_{HEDs} selected for use in risk estimation by target organ/system and exposure category (*i.e.*, acute vs. chronic). The two studies considered for derivation of PODs both received a High in data quality evaluation and all derived BMDLs were considered similarly reasonable for use in risk estimation. Therefore, EPA selected the lowest resulting POD among BMDL modeling results in order to be health-protective.

Table 3-12. PODs Selected for Risk Estimation for Each Target Organ/System

Toxicity Endpoint		POD _{HED} (mg/kg-d)	Benchmark MOE
Effects following acute exposure			
Thyroid	Decreased maternal T4 (Ema et al. 2008)	22.5	30
Developmental	F2 generation offspring loss (Ema et al. 2008)	9.03	100
	Decreased F2 generation pup weight (Ema et al. 2008)	89.6	100
	Delayed F2 generation eye opening (Ema et al. 2008)	28.73	100
Effects following chronic exposure			
Thyroid	Decreased T4 (Ema et al. 2008)	1.68	300
Liver	Increased relative liver weight and vacuolization (WIL Research 2001)	24	1000
Female Reproductive	Reduced primordial follicles (Ema et al. 2008)	0.689	30
Developmental	F2 generation offspring loss (Ema et al. 2008)	9.03	100
	Decreased F2 generation pup weight (Ema et al. 2008)	89.6	100
	Delayed F2 generation eye opening (Ema et al. 2008)	28.73	100

3.2.6 Assumptions and Key Sources of Uncertainties for the Human Health Hazard Assessment

3.2.6.1 Toxicokinetics

In vivo animal studies of the individual isomers have not been conducted. Therefore, it is not possible to predict whether the toxicity of an environmental HBCD mixture would differ from the toxicity of commercial mixtures (*i.e.*, those tested in toxicity studies). It is known, however, that the three major isomers have somewhat different physical/chemical properties (see Section 1.1) and differ toxicokinetically. For example, the α -isomer accumulates to a greater extent in tissues, especially fat, when compared to γ - or β -HBCD; γ - and β -HBCD are more rapidly and extensively metabolized than α -HBCD (see Section 3.2.2.1.3). Mechanistic studies provide limited evidence of differences in biological activity of the three. Thus, the composition of HBCD mixtures to which humans are exposed is likely to differ from the commercial mixtures used in toxicity testing. Whether, and to what extent, the toxicity of the environmental mixtures differs from the toxicity of the commercial mixtures used to derive the PODs is not known based on the available health effects literature. Similarly, HBCD toxicokinetics including absorption and bioaccumulation differ greatly among isomers and are greatly affected by the relative fat content of tissues and surrounding media (*e.g.*, water, air, diet, breastmilk). For both consistency and health-protectiveness, these issues were accounted for by utilizing the upper range of absorption estimates across available studies and including a 10X subchronic-to-chronic UF based on assumed increasing bioaccumulation over time. This adjustment was not included for developmental endpoints or for effects observed following multi-generational exposure, which should already encompass chronic bioaccumulation. EPA believes that the use of this 10X uncertainty factor is likely to be protective of risk from bioaccumulation in human tissues, however there is insufficient available data to confirm this presumption.

EPA utilized data exclusively from oral studies in developing PODs. While it is assumed that any inhaled particulates will be either absorbed through the lung or swallowed and absorbed in the GI, there could be potentially significant differences metabolic outcomes between these routes. Similarly, oral data was extrapolated for evaluating dermal exposure. The absence of a usable PBPK model to quantitatively account for differences between routes represents an important uncertainty when considering the application of oral PODs to other exposure routes.

EPA assumed an upper-end dermal absorption estimate of 6.5% based on a steady-state value from *in vitro* data following 24hr HBCD exposure as a thin, evenly distributed layer on skin. The actual percentage of HBCD absorbed dermally is variable based on multiple factors including the relative percentage of each isomer in the mixture and the relative ratio of sweat to sebum on skin. This value likely overestimates average dermal absorption when accounting for other factors such as washing or wiping skin clean and uneven distribution along the skin surface area. Additionally, the test data involves HBCD dissolved in acetone, where HBCD is much more soluble than in water.

3.2.6.2 Human Health Endpoints

PODs were derived from two studies, ([Ema et al. 2008](#)) and ([WIL Research 2001](#)). These studies were selected because they both scored high in data evaluation, followed OECD guidance and Good Laboratory Practice, and were of longer duration with effects observed more consistently than other high-quality studies that we evaluated. PODs were derived from these studies using BMD modeling when possible in order to obtain more precise values. BMD modeling results always contain some level of uncertainty, and various factors such as model fit and BMR selection may have a large effect on the final POD value.

Endpoints for Acute Exposures

EPA considered the two developmental toxicity endpoints to be applicable to acute exposures. There is uncertainty surrounding this consideration because the precise critical exposure window is unknown and it is unknown how well the two generational rodent study predicts acute effects in humans. EPA determined that the sustained persistence of HBCD in human tissue suggests that a single exposure could have sustained effects. Therefore, despite the uncertainties, neonatal mortality and body weight reduction were considered relevant to acute exposures. Offspring loss represents the most severe endpoint representing the developmental toxicity hazard and is also the lowest available POD relevant to acute exposures, thus making EPA's approach health protective. EPA also considered maternal decreases in T4 levels for acute exposure scenarios, because short-term changes in thyroid hormones may result in irreversible developmental outcomes such as neurotoxicity and other effects. There are no available studies examining acute developmental HBCD exposure, however there is evidence of acute developmental neurotoxicity (Sections 3.2.3.1.5 and 3.2.4.1.5) and evidence from other thyroid disruptors suggests that acute or short-term exposure can result in thyroid hormone effects ([Paul et al. 2010](#); [Hedge et al. 2009](#); [Zhou et al. 2001](#)). Therefore, it is assumed that decreased maternal T4 can serve as a sensitive quantitative measure of potential developmental effects that cannot otherwise be quantified.

Endpoints for Chronic Exposures

The available information on weight of evidence and HBCD mode of action suggests that most if not all HBCD human health hazard endpoints are downstream of dysregulation of the hypothalamic-pituitary-thyroid axis as indicated by decreased T4 levels. Therefore, in addition to representing the lowest available POD, changes in T4 thyroid hormone levels were identified as the most important endpoint relevant to chronic exposures. There is some uncertainty over the use of rodent thyroid hormone data for quantitative human health risk assessment, however the complexity of the system makes it difficult to determine whether rodents would in fact be more sensitive to the specific effects of HBCD. Direct extrapolation of adult rodent thyroid hormone effects to adult humans and use of a 10% BMR is health-protective and may potentially overestimate risk to human adults. However, developmental effects of thyroid disruptors following gestational exposure are expected to be highly comparable between rats and humans, with substantially increased susceptibility in developing individuals of both species compared to adults. While there are some significant differences in the thyroid system between rodent and human adults, gestational HBCD exposure is likely to result in quantitatively similar developmental outcomes. Therefore, there is reduced concern about overestimation when considering thyroid hormone changes as a biochemical marker of downstream developmental toxicity.

No BMD model provided adequate fit to the data from ([WIL Research 2001](#)) and therefore a LOAEL value was used, introducing additional uncertainty in the form of a large cumulative uncertainty factor and benchmark MOE. This is likely to overestimate risk for that endpoint due to the large default values used for various uncertainty factors. Nonetheless, EPA believes that the selected PODs best represent the hazards associated with HBCD for quantitative risk estimation. The liver POD from ([WIL Research 2001](#)) is still less protective than the thyroid effects POD from ([Ema et al. 2008](#)), so its inclusion does not significantly impact the risk conclusions.

Additionally, EPA determined that there was evidence to support potential nervous system effects following HBCD exposure, however limitations in the available data precluded use of any particular study for dose-response analysis of the hazard. Nonetheless, other more sensitive endpoints such as thyroid hormone changes are expected to be protective of neurotoxicity and any other qualitative health effects. Overall, there is medium confidence in all endpoints applicable to chronic exposure, including

the most sensitive endpoint of thyroid effects. There is additionally some uncertainty in the evaluation of inhalation hazards due to the lack of reasonably available subchronic or chronic inhalation studies. The 14-day study by ([Song et al. 2016](#)) only performed gross pathological examination of organs and did not closely examine respiratory-specific indications of toxicity such as measuring bronchoalveolar lavage fluid (BALF).

3.2.7 Potentially Exposed or Susceptible Subpopulations

TSCA requires that a Risk Evaluation “determine whether a chemical substance presents an unreasonable risk of injury to health or the environment, without consideration of cost or other non-risk factors, including an unreasonable risk to a *potentially exposed or susceptible subpopulation* (PESS) identified as relevant to the Risk Evaluation by the Administrator, under the conditions of use.” TSCA Section 3(12) states that “the term ‘potentially exposed or susceptible subpopulation’ means a group of individuals within the general population identified by the Administrator who, due to either greater susceptibility or greater exposure, may be at greater risk than the general population of adverse health effects from exposure to a chemical substance or mixture, such as infants, children, pregnant women, workers, or the elderly.” In developing the hazard assessment, EPA evaluated available data to ascertain whether some human subpopulations may have greater susceptibility than the general population to the chemical’s hazard(s). As discussed further, EPA identified the following susceptible groups: pregnant women, women of reproductive age who may become pregnant, developing fetus and breastfed infants, postnatal infants, infants, obese individuals or those on a high-fat diet, and individuals with pre-existing health conditions or genetic predispositions.

Early lifestages are potentially susceptible to HBCD exposure. HBCD is widely detected in breast milk and umbilical cord serum, indicating a strong potential for prenatal and lactational exposure ([Fångström et al. 2008](#); [Kakimoto et al. 2008](#); [Meijer et al. 2008](#); [Fangstrom et al. 2005](#)). Additionally, HBCD has been detected in placenta and fetal liver tissue ([Rawn et al., 2014a](#)).

In animal studies, HBCD exposure resulted in thyroid alterations. Thyroid hormones play a critical role in coordinating complex developmental processes, and perturbations of thyroid hormone levels in a pregnant woman or neonate can have persistent adverse health effects for the child ([Zoeller et al. 2007](#)), including adverse neurological outcomes ([Finken et al. 2013](#); [Julvez et al. 2013](#); [Román et al. 2013](#); [Henrichs et al. 2010](#); [Haddow et al. 1999](#)). During early gestation, the developing fetus relies solely on thyroid hormones of maternal origin. As the fetus begins to produce thyroid hormones, there is less reliance on maternal thyroid hormones; however, early development remains a sensitive life stage for hormone deficits, largely due to minimal reserve capacity when compared to adults ([Gilbert and Zoeller 2010](#)). Effects on female reproduction parameters are an additional consideration for identifying pregnant and lactating females as a susceptible subpopulation.

Some gender-specific differences in distribution, metabolism, and elimination of HBCD have been noted in animals. A toxicokinetic study in rats administered a single oral dose of [¹⁴C]-HBCD found that males had faster elimination rates and lower tissue concentrations when compared to females ([Yu and Atallah 1980](#)). These data are consistent with observations that female rats had higher liver concentrations of HBCD following repeated oral exposure for 28 days ([van der Ven et al. 2006](#)) or following gestational, lactational, and dietary exposure ([van der Ven et al. 2009](#)). Measures of mechanistic endpoints provide limited evidence of gender-specific responses to HBCD. For example, ([Germer et al. 2006](#)) reported significant induction of CYP3A1/3 mRNA and the associated proteins in both sexes of rats exposed to HBCD for 28 days, but the effect was greater and occurred at lower doses in females (doses of ≥ 3 mg/kg-day in females and ≥ 30 mg/kg-day in males). In another 28-day study, female rats exposed to HBCD had, overall, a significantly higher number of up- or down-regulated

hepatic genes than males ([Cantón et al. 2008](#)); however, genes involved in phase I and II metabolism were up-regulated predominantly in males. In vivo toxicity studies, however, do not show a clear pattern of sex-specific toxicity associated with HBCD exposure (for non-reproductive/developmental endpoints). It is therefore unclear whether either males or females are more biologically susceptible to HBCD toxicity on non-reproductive/developmental endpoints.

HBCD is preferentially deposited in adipose tissue, especially the α -HBCD isomer (see Section 3.2.2). The bioaccumulative nature of HBCD suggests that individuals who consume a high-fat diet may be at increased risk for HBCD toxicity. Additionally, individuals with higher body fat content may also be at greater susceptibility to HBCD. This is corroborated by multiple studies demonstrating increasing liver toxicity in mice administered a high-fat diet ([Bernhard et al. 2016](#); [Yanagisawa et al. 2014](#)). Specific preexisting conditions that may result in increased liver fat content include obesity, metabolic disease, hypercholesterolemia, non-alcoholic fatty liver disease, alcoholic liver disease, and Hepatitis B or C viral infections. Higher body fat content will also lead to increasing body burden, leading to increased toxicity over time as HBCD is distributed from fat to other tissues.

Humans with pre-existing health conditions or genetic predispositions related to any of the affected health domains (*e.g.*, thyroid, liver, reproductive, neurological, immune) would also be expected to be especially susceptible to HBCD toxicity, perhaps at significantly lower doses than healthy populations.

4 RISK CHARACTERIZATION

4.1 Environmental Risk

The environmental risk characterization of HBCD was conducted to evaluate whether the potential releases of HBCD into various media types will exceed the HBCD concentrations observed to result in hazardous effects to aquatic and terrestrial organisms. In evaluating the environmental hazard of HBCD, a weight of evidence approach was used to select hazard effect concentrations for the derivation of risk quotients for both aquatic and terrestrial organisms. The selected hazard effect concentrations reflect studies with high data quality evaluation scores (as determined by the Systematic Review Metrics for Environmental Toxicological Studies), where measured discrete exposure concentrations resulted in observed effects due to acute and chronic exposures. Algal hazard thresholds were separated from being categorized as an acute or chronic exposure because the relatively shorter study durations used for algal toxicity tests measure toxicological effects (*e.g.*, growth, reproduction) that are typically associated with chronic effects. Concentrations of concern (COCs) are summarized below in Table 4-1 for aquatic organisms. Hazard thresholds are summarized below in Table 4-2 for terrestrial organisms. COCs or toxic reference values (TRVs) were not derived for terrestrial organisms because the general limitations of available HBCD data for terrestrial organisms results in an inability to derive appropriate assessment factors that address uncertainties due to duration, field-to-lab extrapolations, and endpoint-specific modes of actions and implications. Finally, the environmental hazard studies used to derive hazard thresholds and COCs were based on high data quality, measured hazard effects concentrations below the water solubility limits of HBCD, and data relevant to the exposure pathway of interest.

As described in Section 2.2, EPA assessed releases of HBCD to the environment based on the production volume of HBCD, emission factors, and number days of release per year. In a few cases, EPA used TRI release data in lieu of the production volume of HBCD and emission factors. A two-tiered modeling approach was used to predict both surface water and sediment HBCD concentrations using two models, E-FAST (surface water) and the PSC (surface water and sediment). Briefly, E-FAST was used for all conditions of use where water releases were predicted to occur. If the E-FAST predicted 7Q10 surface water concentrations were greater than the chronic or acute COCs, the PSC model was then used to confirm whether the predicted surface water concentration exceeds the chronic or acute COC. While both E-FAST and PSC consider dilution and variability in flow, the PSC model can further estimate a time-varying surface water concentration, partitioning to suspended and settled sediment, and degradation within compartments of the water column.

As explained in Section 2.3, EPA used Standard Industrial Classification (SIC) codes to determine industry-specific dilution factors and stream flows to predict surface water and sediment HBCD concentrations. In lieu of having site-specific release information for HBCD, EPA used SIC code information to determine 10th and 50th percentile flow rates to crosswalk with specific COUs. Surface water releases for each exposure scenario were utilized to estimate surface water concentration using flow values from both the 10th and 50th percentile facility for the SIC code. The 10th percentile flow values are approximately a factor of 10 lower than the 50th percentile flows for the SIC codes chosen (lower flow volume will result in higher predicted concentrations of HBCD in the surface water and sediment). The 10th and 50th percentile facilities were estimated in the Risk Evaluation to account for the variability in receiving stream flows (all risk estimates are provided in Appendix J).

As described in Section 2.3, to assess the estimated release of HBCD via air deposition from specific exposure scenarios, IIOAC was used to provide an estimated concentration of HBCD that could be in soil via air deposition in both fence line (less than 100 m from an industrial facility) and community

(100-1,000 m from an industrial facility) scenarios. Although the IIOAC was also applied to a generic farm pond setting to calculate concentrations of HBCD in pond surface water and pond sediment, only the soil concentrations resulting from air deposition were used. Estimated surface water and sediment HBCD concentrations using the IIOAC were not used because as compared to E-FAST or the PSC, IIOAC is a simpler model, providing a two-compartment (surface water and sediment) concentration of HBCD with no accounting for media exchange of the chemical of interest or partitioning to other suspended solids in the surface water.

In addition to modeling, environmental monitoring and biomonitoring data was reviewed, and screened to assess wildlife exposure to HBCD. The key studies that were reviewed and used for the environmental exposure assessment are summarized in Section 2.3.1. Environmental monitoring data summarized below in Table 4-3 and Table 4-4 demonstrate that the predicted surface water and sediment HBCD concentrations using both E-FAST and the PSC support measured HBCD concentrations near industrial facilities in most modeled exposure scenarios, except for exposure scenario 12 (Use of Flux or Solder Pastes). For exposure scenario 12, all predicted releases of HBCD are below the concentrations of HBCD that have been measured in surface water and sediment near industrial facilities, yet some surface water concentrations based on the 7Q10 50th percentile predictions are greater than the measured surface water concentrations of HBCD found near general populations ([Venier et al., 2014](#)).

Incorporating both environmental monitoring and predicted environmental concentrations of HBCD provides information that can be used to evaluate exposure scenarios within each COU. Environmental monitoring data cannot provide HBCD release information that can be attributed to a specific exposure scenario or exposure scenario-specific parameter, nor can it be used to determine HBCD releases from a specific time period (*i.e.*, historic or current releases). However, the incorporation of measured environmental monitoring data does provide context for the persistence of HBCD in the environment, despite recently observed reductions in HBCD production and use. Environmental monitoring data also provides insight regarding how previous releases of HBCD may also contribute to the current environmental exposures of HBCD.

Modeled HBCD surface water and sediment concentrations were obtained by using information that is specific to an exposure scenario or that pertains to an industrial or commercial sector that is related to an exposure scenario (*e.g.*, polymer processing, use of spray polyurethane foam). Modeled HBCD surface water and sediment concentrations however can only be attributed to the assessed releases in the case of each exposure scenario. Although HBCD is expected to partition out of the water column quickly, thereby reducing exposure for pelagic organisms, modeled HBCD surface water and sediment concentrations also do not account for the bioavailability of HBCD to pelagic organisms due to the presence of suspended solids (*i.e.*, resuspension of sediment, presence of natural organic matter). Therefore, predicted surface water concentrations used to characterize risk from surface water releases associated with current conditions of uses may underestimate exposure to HBCD for pelagic organisms.

To characterize environmental risk due to historical activities (as explained in Section 1.2.9), monitoring approaches were used to evaluate exposure. Monitoring information likely encompasses HBCD releases from both historical and ongoing conditions of use and it is difficult to ascertain what proportions may be due to any specific release at a specific time period or geographical location. Risk estimates for background exposure would therefore be expected to incorporate exposures from any and all potential historical uses that may have resulted in releases to the environment, and inclusion of any historical

COUs in the Risk Evaluation does not result in additional environmental exposures beyond what was previously assessed based on monitoring data. Chronic exposures are being evaluated for historical activities of HBCD primarily because of the persistent, bioaccumulative and toxic (PBT) nature of HBCD, and the lack of information regarding the explicit releases from historical uses and the potentially resulting acute exposures. However, it is due to these unique PBT characteristics of HBCD, that EPA acknowledges the likelihood that historical uses of HBCD may contribute to current HBCD exposures.

As stated in Section 2.2.14, EPA performed a sensitivity analysis for three conditions of use using the per site process volumes of 50,000 lbs/yr and 25,000 lbs/yr to examine the effect of process volume on modelled environmental exposures. Due to HBCD declining use, EPA did not identify a current import volume for HBCD, and conservatively used the CDR reporting threshold for small firms of 100,000 lbs/yr as explained in Section 1.2.3. If import is occurring at all, the current import volume could be lower than the threshold volume of 100,000 lbs/yr. For select conditions of use, EPA assessed the most recently identified import volume in 2017 of ~50,000 lbs/yr (see Table 1-4) and to account for the declining use of HBCD, EPA also considered 25,000 lbs/yr. The selected conditions of use (Repackaging of Import Containers, Manufacturing of XPS foam from XPS masterbatch, and Manufacturing of EPS foam from EPS resin) considered in the sensitivity analysis represent conditions of use that are expected to result in high surface water and sediment concentrations.

KABAM (v1) predictions of HBCD bioavailability through diet and water are also used to categorize exposure and predicts body burdens and the contribution to body burden due to both diet and media exposure. Predicted bioaccumulation, bioconcentration and biomagnification factors can also be predicted for representative organisms within each trophic level. American kestrel and Sprague Dawley rats are used as proxy organisms for terrestrial avian and mammalian wildlife organisms, respectively, that may be exposed to HBCD through trophic transfer and various media exposure. Specifically, for this model, based on the assumption that the modeled organisms will experience the same hazardous effect as those of the proxy organisms, hazard data on the proxy organisms are also input parameters for KABAM. Both the predicted hazard effect concentrations and exposure to HBCD through diet and media exposures are used to calculate risk estimates for mammal and avian species within multiple trophic levels.

For the estimation of environmental risk to wildlife via trophic transfer (dietary exposure), the hazard thresholds and environmental exposure data (*e.g.*, media or tissue HBCD concentrations) selected were based on studies that have been evaluated through the Systematic Review Process; the hazard effect concentrations and environmental media or tissue concentrations of HBCD were evaluated as high quality studies using Systematic Review Environmental Hazard or Exposure Metrics, respectively. As noted previously, one of the constraints to characterizing dietary exposure and estimating HBCD trophic transfer in aquatic and terrestrial ecosystems is having hazard data where the exposure regime and methodology used to quantify chemical uptake used is compatible with the available monitoring data. This evaluation of environmental risk resulting from trophic transfer is limited to the available data and exposure factors, therefore risk quotients were only calculated for kestrel, osprey (via allometric scaling from Kestrel reproductive toxicity data), rainbow trout and earthworms because dietary exposure to HBCD was available ([Ferne et al. 2011](#); [Aufderheide et al. 2003](#); [Wildlife Intl 1997a](#))

There are many potential sources of uncertainty in all of the parameters involved in environmental exposure estimates. As presented in Table 2-114, the greatest influence on exposure estimates given the associated uncertainty and sensitivity (effect on the final values) stems from the selection of emission

factor and days of release. Production volume is highly uncertain but not very sensitive, while other factors such as physical-chemical properties, BAF, HBCD half-lives, and exposure model parameters were all estimated to contain low uncertainty. In order to account for these uncertainties and variability among release estimates and exposure considerations including wastewater treatment, EPA provided risk estimates based on a range of exposure sub-scenarios. EPA believes that these sub-scenarios sufficiently capture the range of risk estimates for all reasonably expected environmental exposures, with minimal remaining unaccounted for uncertainty. Therefore, EPA has high confidence in the range of risk estimates for the highly-exposed aquatic and terrestrial organisms.

4.1.1 Environmental Risk Estimation

The environmental risk of HBCD is characterized by calculating risk quotients (RQs) ([U.S. EPA, 1998a](#); [Barnthouse et al., 1982](#)). The concentrations of concern (COCs) derived from hazard data are used to calculate RQs for aquatic organisms. The hazard effects concentrations are used to calculate RQs for terrestrial organisms (COC calculation methodologies, specified below, were not originally meant for terrestrial organisms). The environmental concentration for each compartment (*i.e.*, wastewater, surface water, sediment, soil) is based on measured and/or modeled concentrations of HBCD.

4.1.1.1 Environmental Effect Levels of HBCD

The methods for calculating the environmental concentrations of concern (COCs) are based on published EPA methods ([U.S. EPA, 2013a](#); [2012d](#)). As described above, the selection of hazard effect concentrations was based on a weight of the scientific evidence approach that takes into consideration: data evaluation quality scores, relevancy of exposure and effect measured, and the availability of supporting studies.

The environmental hazard evaluation that is summarized in Section 3.1 of this evaluation is based on high quality studies. The algal hazard threshold was based on a 72-hr exposure to HBCD ([Walsh et al., 1987](#)) with measured observed hazardous effect (*i.e.*, growth) on a marine algae species (*Skeletonema costatum*), where the exposure concentration was below the water solubility of HBCD. As described in Sections 2.1.2.6 and 2.1.2.7, the ubiquitous presence of HBCD in the tissues of marine organisms indicates the exposure of HBCD to marine organisms, despite a lack of information regarding the source of HBCD. The data availability for freshwater pelagic organisms exposed to HBCD was more expansive, and as the industrial release of HBCD is more likely to occur in freshwater water bodies, the acute and chronic COCs were based on hazard thresholds for freshwater organisms. The acute hazard threshold is based on a 96-hr HBCD exposure to zebrafish embryos, where hatching delay occurred when exposed to 2 µg/L ([Hu et al. 2009a](#)), resulting in an acute COC of 0.4 µg/L. The chronic MATC of 4.2 µg/L derived from a 21-d study using the aquatic invertebrate, *D. magna*, was used to calculate the chronic COC of 0.417 µg/L ([Drottar and Krueger, 1998](#)). The chronic COC to represent benthic organisms (*L. variegatus*) was also based on the same requirements mentioned above ([Oetken et al., 2001](#)). In regard to terrestrial organisms, the effect concentration levels as provided in Table 4-2 similarly represent three trophic levels, and the rationale for selecting these studies is based on high data evaluation quality scores, and the pertinence of the tested exposure and effect measured. The hazard effects concentrations cover a range of observed effects (*i.e.*, growth, reproductive success, oxidative stress), and the potential for organisms to be exposed to such concentrations was evaluated by using both environmental monitoring (*i.e.*, surface water, sediment, and soil) and modeled surface water and sediment HBCD concentrations to calculate risk estimates.

4.1.1.2 Acute and Chronic Concentrations of Concern

The COC's for acute toxicity were determined by dividing the acute effect level (*i.e.*, reduction of

Zebrafish embryo hatching) by an assessment factor of 5, and the algae (*i.e.*, growth) and chronic (*i.e.*, growth of Water Fleas and reproduction of California blackworms) COCs were calculated using an assessment factor of 10. Further details on the calculations used to derive COCs are described above in Section 3.1.5.

Table 4-1. Concentrations of Concern (COCs) Derived to Evaluate Toxicity to Aquatic Organisms for HBCD

Environmental Media	Organism and Endpoint	Hazard Effect Concentration	Assessment Factor	Effect	Concentration of Concern (COC)	Reference	Data Evaluation Score
Surface Water	Zebrafish (<i>Danio rerio</i>) 96-hr LOAEL	2 µg/L	5	Delayed embryo hatching	0.4 µg/L	(Hu et al. 2009a)	High
	Water flea (<i>D. magna</i>) 21-d MATC	4.2 µg/L	10	Reduced length of surviving young	0.417 µg/L	(Drottar and Krueger 1998)	High
	Marine algae (<i>S. costatum</i>) 72-hr EC50	10 µg/L	10	Growth Rate	1 µg/L	(Walsh et al. 1987)	High
Sediment	California blackworm (<i>Lumbriculus variegatus</i>) 28-day MATC	15,700 µg/kg dw	10	Reduction in worm number	1,570 µg/kg/dw	(Oetken et al. 2001)	High

The methodology used to derive concentrations of concern as presented in Table 4-1 are described above in Sections 3.1.6 and 3.1.7.

Table 4-2. Hazard Effect Concentrations used to Evaluate Toxicity to Terrestrial Organisms

Organism and Endpoint	Hazard Effect Concentration	Effect	Reference	Data Evaluation Score
Maize 4-d LOAEL	2 µg/L	Growth (root and shoot)	(Wu et al. 2016c)	High
Earthworm 14-d MATC	173,000 µg/kg bw	Reproduction/mortality	(Aufderheide et al. 2003)	High
American kestrel 21-d LOAEL	0.51 mg/kg bw	Reproduction (clutch size, egg production timing)	(Fernie et al., 2011)	High
Rat 2-generation NOAEL	10 mg/kg bw	Thyroid hormones response, Reproduction	(Ema et al. 2008)	High

Studies where terrestrial organisms were exposed to HBCD were evaluated and those with high data evaluation scores (using environmental Systematic Review metrics) and relevant environmental exposure pathways were used to assess risk to terrestrial organisms. The studies identified in Table 4-2 provide a summary of studies where chronic exposures to HBCD were conducted with terrestrial

organisms. The organisms identified in the abovementioned studies were chosen to represent their respective taxa classifications (*i.e.*, vegetation, invertebrate, vertebrate). Out of the four terrestrial vegetation studies (all rated with high data evaluation scores), (Wu et al. 2016c) exposed maize to HBCD via water exposure; without information regarding biosolid application and exposure, this study was the most relevant because the exposure is not diastereomer-specific and has a discrete effect concentration resulting in significant reductions in root and shoot growth. Risk estimates were not calculated for maize because it is unlikely that terrestrial plants will be exposed to HBCD through precipitation (as done in the study). For soil organisms in the terrestrial environment the earthworm (*E. fetida*) is the most biologically-relevant species for the terrestrial soil environment. The effects of HBCD exposure to *E. fetida* has been summarized in the previous section reporting a MATC of 173,000 µg/kg bw (Aufderheide et al. 2003). In the 10 highly-evaluated studies, chronic exposures to HBCD resulted in varying reproductive and developmental effects (*e.g.*, reduced hatching time, smaller egg production, and the presence of HBCD in eggs) in terrestrial avian species (Table 3-1). As described in Table 4-2, rats exposed to HBCD resulted in a T4 response in male rats, which corresponds with downstream reproductive and developmental effects at similar doses (Ema et al. 2008).

4.1.2 Calculation of Risk Quotient (RQ) Values for HBCD

Environmental risk was characterized by calculating risk quotients or RQs (U.S. EPA, 1998a; Barnthouse et al., 1982); the RQ is defined as:

$$\text{RQ} = \text{Environmental Concentration} / \text{Effect Level}$$

For aquatic organisms, the “effect level” is a derived COC based on a hazard effects concentration. For terrestrial organisms, the “effect level” is the hazard effect concentration identified in Table 4-2. COC calculation methodologies were not originally meant for terrestrial organisms and as mentioned above, COCs or TRVs were not calculated for terrestrial organisms, where an assessment factor is data-derived to compensate for varying sources of uncertainties associated with the interpretation and extrapolation of a hazard threshold. An RQ equal to 1 indicates that the exposures are the same as the concentration that causes effects. If the RQ is above 1, the exposure is greater than the effect concentration and risk is indicated. If the RQ is below 1, the exposure is less than the effect concentration and risk is not indicated.

4.1.3 Risk Estimation Approach

The concentrations of concern (COC) used to calculate risk quotients (RQ) for aquatic organisms were derived from hazard values resulting from acute and chronic exposures to HBCD. RQs for terrestrial organisms were derived from the raw hazard values resulting from acute and chronic exposures to HBCD (no COCs were calculated).

Environmental risk for conditions of use releases was primarily characterized with modeled releases resulting in estimated media-specific HBCD environmental concentrations, and environmental monitoring information was used to characterize background exposure to HBCD that is not attributed to exposure scenario-specific releases for the abovementioned conditions of use or historical uses. However, in lieu of having exposure scenario-specific media releases, background monitoring data was used to characterize environmental risk. The totality of background exposure includes steady-state environmental exposures from ongoing releases that are not associated with a particular COU, background/indirect exposures from minor use products (*e.g.*, textiles, electrical and electronic products, adhesives, and coatings) (Section 1.2.8), and releases stemming from historical activities (Section 1.2.9) due to HBCD’s persistence in the environment. Furthermore, background HBCD concentrations derived from measured environmental monitoring data were not aggregated with modeled exposure-scenario-

specific releases for any media type (*e.g.*, surface water, sediment or soil) to provide an overall total exposure due to previously existing and potentially current releases because of the uncertainty involved in discerning the proportions of HBCD that may have come from releases resulting from either historic or current conditions of uses.

Environmental monitoring data (*i.e.*, surface water, sediment and soil concentrations of HBCD) are also evaluated below, in the context of the same hazard and COC values as those used for the modeled surface water and sediment HBCD concentrations predicted by E-FAST and PSC, and the soil concentrations predicted by IIOAC (via air deposition). The use and derivation of environmental media HBCD concentrations attained from various sources of monitored data is discussed above in Sections 2.3.2. and 2.3.3. RQ calculations using environmental monitoring data are provided below in Table 4-3, Table 4-4, and Table 4-6. RQ calculations using environmental modeling data are provided below in Table 4-5 (surface water and sediment), and Appendix J (soil).

Briefly, environmental monitoring data sampled from the U.S. as well as other high-income countries (rationale provided in Section 2.3.2) with enough data for the estimation of an arithmetic mean and 90th percentile value were used to calculate risk estimates. As explained in Section 2.4.2, sampling location characterization is not feasible because not all literature sources provide this information nor is it always possible to categorize environmental monitoring data based on industrial sector. Therefore, the monitoring data is categorized by qualifiers study authors used to indicate sampling proximity to a point source or non-point source of HBCD.

Risk estimation approach for aquatic organisms

RQ calculations using predicted modeling data are provided below in Table 4-5 (surface water and sediment) and Table_Apx J-13 (soil). Surface water and sediment HBCD concentrations were not predicted for the following conditions of uses: “Use: Installation of Automobile Replacement Parts”, “Processing: Formulation of Flux/Solder Pastes”, “Processing: Recycling of electronics waste containing HIPS that contains HBCD” and “Use: Other Formulated Products and Articles (*e.g.*, adhesives, coatings, textiles, and electronics)” because surface water releases were not predicted to occur (as explained in Section 2.2). Surface water releases are likely to occur for all the other exposure scenarios, and therefore have risk characterized for aquatic organisms. However, although water releases are predicted to occur for the condition of use “Land disposal of textiles, electrical and electronic products, adhesives, and coatings”, via the potential leaching capacity of HBCD from these facilities (not through the disposal process of these formulated products and articles) or runoff, there is very limited information regarding this topic. In lieu of having media-specific release information for this condition of use via leaching or surface runoff, background information (measured monitoring data) is used as a proxy to characterize the risk for the “Land disposal of textiles, electrical and electronic products, adhesives, and coatings”.

Further explanations regarding model parameters used for the different scenario labels are provided in Section 2.3.2. Briefly, E-FAST was used for all conditions of use where water releases were likely to occur. If the EFAST predicted 7Q10 surface water concentrations (SWCs) were greater than the COCs, the PSC model was then used to affirm whether the predicted SWC exceeds the COCs using different parameters. EFAST considers dilution and variability in flow for days exceeded estimates. The PSC also considers dilution but can further estimate a time-varying surface water concentration, partitioning to suspended and settled sediment, and degradation within compartments of the water column within a river segment. To derive risk estimates for pelagic species, the 1- and 21-d predicted surface water concentrations were compared to the acute, algae, and chronic COCs. To derive risk estimates for

benthic species, the 28-d predicted sediment concentrations based on either the 11- or 128-d HBCD half-lives were compared to the chronic COC for lumbriculus. Modeled surface water and sediment concentrations were used to characterize risk for aquatic organisms for all exposure scenarios with surface water releases except for “Land disposal of textiles, electrical and electronic products, adhesives, and coatings” because as stated above, there is limited data regarding the HBCD leaching from associated facilities (described in Section 2.4.5.2). Therefore measured background information (*e.g.*, near industrial facilities and near general population) is used to characterize risk to aquatic organisms due to this condition of use, while understanding that measured background information for specific media types can be attributed to any releases that occur due to historic or current conditions of use.

The sensitivity analysis on how production volume and percentage of HBCD removal from the direct release of HBCD into surface water was conducted to reflect declining production volumes and the likelihood that the HBCD will partition to TSS (Appendix J.1.2). The surface water and sediment concentrations were predicted for three production volumes (100,000, 50,000 and 25,000 lbs/yr) due to the declining use of HBCD and lack of information regarding the current import volume of HBCD to account for the current processing and use associated with HBCD. Furthermore, the selected exposure scenarios (Repackaging of Import Containers, Manufacturing of XPS foam from XPS masterbatch, and Manufacturing of EPS foam from EPS resin) were considered in the sensitivity analysis using the three production volumes because they were expected to result in high surface water and sediment concentrations. The estimated emissions from the three exposure scenarios cover emission data from process-specific industry data and OECD ESDs. The resulting risk estimates from the sensitivity analysis regarding production volume will not be used for the risk conclusions because the lower volumes of predicted HBCD production and use are not certain and instead provide support for the current estimates based on a production volume of 100,000 lbs/yr; based on estimates using the 10th percentile surface water and sediment HBCD concentrations, decreasing the production volume does not reduce the number of exposure sub-scenarios with environmental risk.

Risk estimation approach for terrestrial organisms

EPA used IIOAC to estimate air deposition from facility releases, and calculated resulting soil concentrations near the facilities. IIOAC uses pre-run results from a suite of AERMOD dispersion scenarios at a variety of meteorological and land-use settings, as well as release emissions, to estimate particle deposition at different distances from sources that release chemical substances to the air. To derive risk for soil organisms, the predicted soil concentration from air deposition is compared to the chronic COC for earthworms.

Soil concentrations (via air deposition) were not predicted for the following conditions of use: “Use: Installation of Automobile Replacement Parts”, and “Use: Other Formulated Products and Articles (*e.g.*, adhesives, coatings, textiles, and electronics)”, because air releases were not predicted to occur as explained in Section 2.2). Air releases of HBCD are likely to occur for all the other exposure scenarios, and therefore have risk characterized for terrestrial soil organisms.

Predicted soil concentrations of HBCD (via air deposition modeling) were used to characterize risk for terrestrial soil organisms for all exposure scenarios with air releases except for the two listed above, as well as “Recycling of electronics waste containing HIPS,” and “Land disposal of textiles, electrical and electronic products, adhesives, and coatings.” Although air releases are predicted to occur for the condition of use “Recycling of electronics waste containing HIPS,” a semi-quantitative screening approach (as explained below in Section 4.1.3.2.3) was used to compare industrial releases associated with this exposure scenario to those of other exposure scenarios with air releases; the release days and

amount of HBCD released were factors considered to determine whether this exposure scenario will likely have soil concentrations of HBCD that may exceed the chronic hazard threshold for earthworms. In regards to “Land disposal of textiles, electrical and electronic products, adhesives, and coatings”, there is limited data regarding the release of HBCD into air from associated facilities. Therefore measured background information (e.g., near industrial facilities and near general population) is used to characterize risk to terrestrial soil organisms due to this condition of use, while understanding that measured background information for specific media types can be attributed to any releases that occur due to historic or current conditions of use.

4.1.3.1 Risk Estimation Based on HBCD Surface Water and Sediment Concentrations using Environmental Monitoring Data and Modeling Results

The COCs and hazard effect concentrations used to calculate RQs below are summarized above in Section 4.1.2, with the respective toxicity data.

4.1.3.1.1 Risk Estimation Based on Surface Water and Sediment Monitoring Data

Table 4-3. Calculated Risk Quotients based on HBCD Surface Water ($\mu\text{g/L}$) Concentrations as Reported in Environmental Monitoring Studies

Site Characterization	Surface Water Concentrations ($\mu\text{g/L}$)		Acute RQ (COC: 0.4 $\mu\text{g/L}$)		Algae RQ (COC: 1 $\mu\text{g/L}$)		Chronic RQ (COC: 0.417 $\mu\text{g/L}$)	
	Mean of Mean	Avg of 90th Percentile	Risk estimate using: Mean of Mean	Risk estimate using: Avg of 90th Percentile	Risk estimate using: Mean of Mean	Risk estimate using: Avg of 90th Percentile	Risk estimate using: Mean of Mean	Risk estimate using: Avg of 90th Percentile
Near Industrial Facility (Point Source) ^a	0.84	0.99	2.10	2.48	0.84	0.99^c	2.02	2.38
Near General Population (Non-Point Source) ^b	0.00041	0.0008	1.03E-03	2.00E-03	4.10E-04	8.00E-04	9.83E-04	1.92E-03

Values in **bold text and highlighted in red** denote a risk ($\text{RQ} \geq 1$) to the aquatic environment where the surface water concentration (SWC) exceeds the concentration of concern (COC) for acute, chronic and algae environmental hazard. The algae RQ based on the average 90th percentile SWC is bolded to indicate risk.

^aReferences to characterize the mean of the mean and average of 90th percentile SWCs are listed here: ([Ichihara et al. 2014](#); [Kowalski and Mazur 2014](#); [Oh et al. 2014](#)).

^bReferences to characterize the mean of the mean and average of 90th percentile SWCs are listed here: ([Law et al. 2006](#); [Harrad et al. 2009](#); [Ichihara et al. 2014](#); [Venier et al. 2014](#)) Values in **bold text and highlighted in red** denote a risk ($\text{RQ} \geq 1$) to the aquatic environment where the surface water concentration (SWC) exceeds the concentration of concern (COC) for acute, chronic and algae environmental hazard. The algae RQ based on the average 90th percentile SWC is bolded to indicate risk.

^c The RQ of 0.99 is an indicator of risk to algae because although the surface water concentration of HBCD measured near industrial facilities is an average of the high end (90th percentile) measured concentrations reported in these studies, there were measured concentrations used that are above 0.99 $\mu\text{g/L}$ ([Ichihara et al. 2014](#); [Kowalski and Mazur 2014](#); [Oh et al. 2014](#)). To be more conservative of the wide ranges of HBCD measured concentrations in surface water, a RQ of 0.99 is still a likely indicator that algae near industrial facilities will be exposed to HBCD at concentrations that may exceed the COC of 1 $\mu\text{g/L}$.

Table 4-4. Calculated Risk Quotients based on HBCD Sediment Concentrations ($\mu\text{g}/\text{kg}$) as Reported in Environmental Monitoring Studies

Site Characterization	Sediment Concentrations ($\mu\text{g}/\text{kg}$)		Chronic RQ (COC: 1,570 $\mu\text{g}/\text{kg}$)	
	Mean of Mean	Avg of 90th Percentile	Mean of Mean	Avg of 90th Percentile
Near Industrial Facility (Point Source) ^a	3443	5073	2.193	3.231
Near General Population (Non-Point Source) ^b	6.2	19.8	0.0039	0.0126

Values in **bold text and highlighted in red** denote a risk ($\text{RQ} \geq 1$) to the aquatic environment where the sediment concentration exceeds the concentration of concern (COC).

^aReferences to characterize the mean of the mean and average of 90th percentile sediment concentrations are listed here: ([Sellstrom et al. 1998](#); [Haukås et al. 2010b](#); [La Guardia et al. 2010](#); [Oh et al. 2014](#); [Al-Odaini et al. 2015](#); [Stiborova et al. 2017](#))

^bReferences to characterize the mean of the mean and average of 90th percentile sediment concentrations are listed here: ([Ramu et al. 2010](#); [Klosterhaus et al. 2012](#); [Yang et al. 2012](#); [Harrad et al. 2009](#); [Haukås et al. 2009](#); [Kohler et al. 2008](#); [Minh et al. 2007](#); [Morris et al. 2004](#); [Remberger et al. 2004](#); [Jeong et al. 2014](#); [Luigi et al. 2015](#); [Lyons et al. 2015](#); [Al-Odaini et al. 2015](#); [Anim et al. 2017](#))

4.1.3.1.2 Risk Estimation Based on Surface Water and Sediment Modeling Data

Table 4-5. Range of Risk Quotients for Modeled Surface Water and Sediment HBCD Concentrations for Each Condition of Use Using a Production Volume of 100,000 lbs/yr (0% removal for direct release)

Exposure Scenario	Surface Water						Sediment			
	Acute		Algae		Chronic		11-d half-life		128-d half-life	
	10 th percentile	50 th percentile	10 th percentile	50 th percentile	10 th percentile	50 th percentile	10 th percentile	50 th percentile	10 th percentile	50 th percentile
Section 2.2.2 – Repackaging of Import Containers (1)	4.3-189	0.09-24.2	1.72-75.6	0.04-0.83	3.5-21.22	0.07-2.26	0.87-4.61	0.02-0.56	2.29-11.91	0.05-1.26
Section 2.2.3 – Compounding of Polystyrene Resin to Produce XPS Masterbatch (2)	3.48-34.75	0.09-2.08	1.39-31.3	0.04-0.83	0.19-4.22	0-0.1	0-0.77	0-0.02	0-1.86	0-0.04
Section 2.2.4 – Processing of HBCD to produce XPS Foam using XPS Masterbatch (3)	0.76-275	0.02-7.33	0.3-110	0.01-2.93	0.04-13.55	0-0.34	0.01-2.22	0-0.06	0.02-2.97	0-0.08
Section 2.2.5 – Processing of HBCD to produce XPS Foam using HBCD Powder (4)	0.91-107	0.02-2.85	0.02-2.85	0.01-1.14	0.05-5.25	0-0.13	0.01-0.87	0-0.02	0.02-1.16	0-0.03
Section 2.2.6 – Processing of HBCD to produce EPS Foam from Imported EPS Resin Beads (5)	89.5-9,900	2.2-262.5	35.8-3,960	0.88-105	33.57-563.55	0.71-12.01	8.73-143.31	0.21-3.52	22.68-361.78	0.48-7.77
Section 2.2.7 – Processing of HBCD to produce SIPs and Automobile Replacement Parts from XPS/EPS Foam (6)	0.97-148.75	0.02-3.93	0.39-59.5	0.01-1.57	0.19-8.47	0-0.18	0-2.15	0-0.05	0-5.43	0-0.12

Risk quotients (RQs) for surface water are calculated using aquatic acute, algae and chronic COCs of 0.4, 1.0 and 0.417 µg/L, respectively. RQs for sediment are calculated using the sediment COC of 1,570 µg/kg. If the predicted surface water or sediment concentration was 0 or if the calculated RQ was < 0.005, the RQ was rounded to 0. Values in bold text and highlighted in red denote exposure scenarios where at least half of the model sub-scenarios have risk (RQ≥1) to the pelagic or benthic environment where the surface water concentration (SWC) or sediment concentration, respectively, exceeds the concentration of concern (COC) for environmental hazard.

Exposure Scenario	Surface Water						Sediment			
	Acute		Algae		Chronic		11-d half-life		128-d half-life	
	10 th percentile	50 th percentile	10 th percentile	50 th percentile	10 th percentile	50 th percentile	10 th percentile	50 th percentile	10 th percentile	50 th percentile
Section 2.2.9 – Installation of XPS/EPS Foam Insulation in Residential, Public, and Commercial Buildings, and Other Structures (8)	0.05-59.25	0.01-8.45	0.02-23.7	0-3.38	0-4.10	0-0.04	0.06-0.57	0.01-0.07	0.13-1.28	0.01-0.10
Section 2.2.10– Demolition and Disposal of XPS/EPS Foam Insulation Products in Residential, Public and Commercial Buildings, and Other Structures (9)	0.05-59.25	0.01-8.45	0.02-23.7	0-3.38	0-4.10	0-0.04	0.01-0.10	0.002-0.02	0.001-0.01	0.0001-0.0007
Section 2.2.11– Recycling of EPS Foam and Reuse of XPS Foam (10)	1.2-183.25	0.03-4.88	0.48-73.3	0.01-1.95	0.45-9.02	0.01-0.22	0.12-1.48	0-0.04	0.17-1.98	0-0.06
Section 2.2.13 – Use of Flux/Solder Pastes (12)	0.58-1.19	0.02-0.15	0.23-0.47	0.01-0.06	0.03-0.06	0-0.01	0-0.01	0	0.01-0.02	0

4.1.3.1.3 Risk Estimation for the Recycling of Electronics Waste Containing HIPS

To characterize the risk associated with the recycling of electronics waste containing HIPS that contain HBCD, a screening level approach was used to compare the estimates for HBCD release and duration to those used for other conditions of uses. To be specific, for aquatic environments, there is no information available that suggests water releases will occur for this exposure scenario or related COU, therefore surface water and sediment HBCD concentrations were not modeled for this exposure scenario.

However, similar to other exposure scenarios and historical uses that may release HBCD into the aquatic environment, it is likely that the Recycling of Electronic Waste Containing HIPS may have also contributed to measured background concentrations of HBCD discussed above in Section 4.1.3.1.1, and therefore there is potential for there to be risk for aquatic organisms near industrial facilities that are associated with the recycling of electronic waste containing HIPS.

4.1.3.2 Risk Estimation based on HBCD Soil Concentrations using Environmental Monitoring and Modeling Data

4.1.3.2.1 Risk Estimation Based on Soil Monitoring Data

Table 4-6. Calculated Risk Quotients based on HBCD Soil Concentrations ($\mu\text{g}/\text{kg}$) as Reported in Environmental Monitoring Studies

Data Source	HBCD Source	Site Characterization	Soil Concentrations ($\mu\text{g}/\text{kg}$)		Chronic RQ (Hazard effect concentration: 173,000 $\mu\text{g}/\text{kg}$)	
			Mean of Mean	Avg of 90th Percentile	Mean of Mean	Avg of 90th Percentile
Environmental Monitoring	Air Deposition	Near Industrial Facility (Point Source) ^a	1,016	1,254	5.87×10^{-3}	7.25×10^{-3}
		Near General Population (Non-Point Source) ^b	1.4	3.0	8.30×10^{-6}	1.74×10^{-5}
<p>There are no instances of risk estimates that denote a risk ($\text{RQ} \geq 1$ indicating risk) to the terrestrial environment where the soil concentration exceeds the hazard effects concentration for earthworm reproduction (Aufderheide et al. 2003) .</p> <p>^a References to characterize the mean of the mean and average of 90th percentile soil concentrations are listed here: (Remberger et al. 2004)</p> <p>^b References to characterize the mean of the mean and average of 90th percentile soil concentrations are listed here: (Covaci et al. 2009; Newton et al. 2015)</p>						

4.1.3.2.2 Risk Estimation Based on Soil Modeling Data

As presented in Appendix Table_Apx J-13, there are no instances of risk quotients equal to or greater than one (indicating risk) when using the highest IIOAC predictions for soil HBCD concentrations in either the fence line or community scenarios. The results suggest the unlikelihood that any of the exposure scenarios alone will contribute sufficient HBCD to result in risk for terrestrial soil organisms.

The below table presents a summary of risk estimation for soil organisms based on both monitoring and modeling data.

Table 4-7. Calculated Risk Quotients based on HBCD Soil Concentrations ($\mu\text{g}/\text{kg}$) as Reported in Environmental Monitoring Studies and Calculated using Modeling Data

Data Source	HBCD Source	Site Characterization	Soil Concentrations ($\mu\text{g}/\text{kg}$)		Chronic RQ (Hazard effect concentration: 173,000 $\mu\text{g}/\text{kg}$)
Environmental Monitoring	Air Deposition	Near Industrial Facility (Point Source)	50th Percentile	1016	0.0059
			90th Percentile	1254	0.0072
		Near General Population (Background)	50th Percentile	1.44	0
			90th Percentile	3.01	0
Model	Biosolid Application	Agriculture (Point Source) * Based on LaGuardia 2010	Maximum	30.00	0.0002
	Air Deposition	Near Industrial Facility (Point Source)	Maximum	0.13	0
Combined	Air Deposition Near Facility, Biosolid Application, and Background Levels	N/A		41.00	0.0002
There are no instances of risk estimates that denote a risk ($\text{RQ} \geq 1$ indicating risk) to the terrestrial environment where the soil concentration exceeds the hazard effects concentration for earthworm reproduction (Aufderheide et al. 2003). When the RQs are < 0.0001 , the RQ is rounded to 0.					

4.1.3.2.3 Risk Estimation for the Recycling of Electronics Waste Containing HIPS

Risk Estimates for Terrestrial Ecosystems based on Monitoring Data

HBCD releases from the recycling of electronics waste containing HIPS, has been identified as an ongoing COU (associated exposure scenario Recycling of Electronic Waste Containing HIPS), and environmental risk due to potential releases from electronics recycling sites is characterized below using environmental monitoring data provided above in Section 4.1.3.2.1 (same analysis used to evaluate HBCD background exposure). In regards to the use of environmental monitoring data to characterize background HBCD concentrations (where releases from historic and current conditions of use have likely contributed to), risk to terrestrial organisms due to chronic HBCD exposure is characterized by soil concentrations (Table 4-6) measured near industrial facilities (point source exposure) or general population (non-point source exposure).

Risk Estimates for Terrestrial Ecosystems based on Modeling Data

To characterize the risk associated with exposure scenario-specific media releases for each current conditions of use to soil organisms, soil concentrations (via air deposition) were estimated using methods outlined above in Section 2.3. To evaluate environmental risk to soil organisms due to the Recycling of Electronic Waste Containing HIPS, a screening level approach was used to compare the estimates for HBCD air release and duration to those used for other conditions of use. EPA estimated central tendency and high-end air releases of HBCD from electronic recycling sites to be 0.024 and 0.38 kg/site-d, respectively, for a duration of 250 days. EPA compared the air release estimates for electronic recycling sites to those that were previously used to quantify HBCD soil concentration (via air

deposition) for the other conditions of use. The daily release amounts of HBCD and number of release days estimated for electronic recycling sites fall within the range as those used to characterize and estimate soil HBCD concentrations from air deposition for other conditions of use. Specifically, in comparison to exposure scenario 6.12, where the daily release of HBCD (3.8 kg/site-d) and number of release days (300 days) are both higher than those predicted for electronic recycling sites, the resulting soil HBCD concentration for exposure scenario 6.12 is $3.66\text{E-}03$ $\mu\text{g/kg}$ for fence-line communities (near industrial facilities). This exposure scenario's estimated soil concentration of HBCD does not surpass the hazard threshold for soil organisms (173,000 $\mu\text{g/kg}$), and therefore did not result in environmental risk. Due to the unlikelihood that the lower release amounts and days for electronic recycling sites will surpass those used for any of the current conditions of use, soil concentrations of HBCD due to air deposition were not estimated using methods outlined above in Appendix F.1.2 for this condition of use. There are no estimated HBCD soil concentrations resulting from modeled HBCD release via air deposition that exceed the chronic COC for soil organisms (Appendix J.1.3.1) for any conditions of use, including the Recycling of Electronic Waste Containing HIPS.

4.1.3.3 Risk Estimation based on Exposure via Trophic Transfer

To calculate RQs for the organisms in Table 4-8 and Table 4-9, hazard effect concentrations were selected based on high data quality evaluation scores as well as the appropriateness of the endpoint in regards to what is likely a chronic dietary exposure.

As summarized in Table 4-8, risk quotients (RQs) calculated for deer mouse, kestrel and osprey are based on the amount of HBCD consumed per day normalized to body weight as calculated using the values from Table 3-2 (exposure factors were from the U.S. EPA Final Water Quality Guidance for Great Lakes System and U.S. EPA Wildlife Exposure Factors Handbook). The hazard values are described in Section 3.1.2 and the [Systematic Review Supplemental File: Data Extraction Tables of Environmental Hazard Studies](#). The osprey hazard effect concentration is allometrically-scaled from the kestrel 75-d LOAEL (reproductive toxicity).

As summarized in Table 4-9, RQs calculated for rainbow trout and earthworms are based on the amount of HBCD consumed per day normalized to body weight as calculated using the values from Table 3-3 (exposure factors were from the ECHA Guidance on Information Requirements and Chemical Safety Assessment (Environmental Exposure Assessment)). The hazard values are described in Section 3.1.2 and the [Systematic Review Supplemental File: Data Extraction Tables of Environmental Hazard Studies](#).

Table 4-8. Calculated Risk Quotients based on Potential Trophic Transfer of HBCD in Aquatic and Terrestrial Ecosystems Using the U.S. EPA Final Water Quality Guidance for Great Lakes System and U.S. EPA Wildlife Exposure Factors Handbook

Organism	Amount of HBCD consumed per day normalized to body weight (mg/kg bw)	Hazard Effect Concentration (mg/kg bw)	Reference for Hazard Effect Concentration	RQs
Kestrel	0.0005	0.51	(Ferne et al., 2011)	0.001
Osprey	$1 \times 10^{-6} - 2.0$	0.51	(Ferne et al., 2011)	$2 \times 10^{-6} - 3.92$

Values in bold text and highlighted in red denote risk ($\text{RQ} \geq 1$) where the dietary uptake of HBCD exceeds the hazard threshold.

Table 4-9. Calculated Risk Quotients based on Potential Trophic Transfer of HBCD in Aquatic and Terrestrial Ecosystems using the ECHA Guidance on Information Requirements and Chemical Safety Assessment (Environmental Exposure Assessment)

Organism	Amount of HBCD consumed per day normalized to body weight (mg/kg bw)	Hazard Effect Concentration (mg/kg bw)	Reference for Hazard Effect Concentration	RQs
Rainbow trout	16.2	0.0025	(Wildlife Intl 1997a)	6480
Earthworm	18855	173.00	Aufderheide et al. (2003)	109

Values in bold text and highlighted in red denote risk ($RQ \geq 1$) where the dietary uptake of HBCD exceeds the hazard threshold.

4.1.4 Environmental Risk Results

The risk of HBCD to aquatic and terrestrial ecosystems are summarized in Sections 4.1.4.1, and Appendix J. Specifically, Table 4-3, Table 4-4 and Table 4-6 include risk quotients (RQ) based on reported environmental monitoring data for HBCD concentrations in sampled surface water, sediment and soil samples, respectively. Table 4-5 includes RQs based on predicted surface water and sediment concentrations categorized by the different modeling scenarios for each exposure scenario (further details provided in Section 2.3). The presented RQs are based on predicted surface water and sediment concentrations using the 10th and 50th percentile flow. RQs based on predicted soil HBCD concentrations via air deposition, are presented in Section J.1.3.1; there were no RQs equal to or greater than one. Table 4-5 includes RQs for each exposure scenario based on predictions of surface water and sediment HBCD concentrations using the Variable Volume Waterbody Model (VVWM) - Point Source Calculator (PSC). Table 4-8 and Table 4-9 depict RQs that are primarily based on environmental monitoring data, where exposure is further characterized by diet-based exposure factors (U.S. EPA Final Water Quality Guidance for Great Lakes System and U.S. EPA Wildlife Exposure Factors Handbook), or laboratory-derived bioconcentration factors (BCFs).

Risk to the aquatic environment is characterized by evaluating both surface water and sediment concentrations of HBCD, by using both environmental monitoring and predicted surface water and sediment concentrations. Risk to the terrestrial environment was also characterized by using predicted surface water and sediment concentrations as input values for KABAM (v1), in addition to soil HBCD concentrations attained from environmental monitoring studies and predicted using the IIOAC air deposition HBCD concentrations. Furthermore, to evaluate how HBCD trophic transfer would impact predators in both aquatic and terrestrial environments, risk to both aquatic and terrestrial avian species was derived for osprey, and kestrel, respectively, where the Kestrel reproductive hazard effect concentration was allometrically-scaled for osprey. Due to the lack of hazard data regarding the exposure of HBCD to higher trophic level aquatic organisms (despite large amounts of biomonitoring data) and the greater likelihood that HBCD will be released into aquatic environments, osprey was chosen as a representative species for an aquatic predator because the diet is easily characterized by fish consumption. Measured data demonstrates that HBCD will bioconcentrate in Rainbow trout and Earthworms (Table 3-3), therefore risk was also characterized to evaluate whether HBCD poses risk to organisms where high HBCD bioconcentration has already been quantified.

The red shaded values in these tables denote when at least half of the calculated RQs are equal to or greater than one, indicating that the modeled or measured surface water, sediment or soil concentration of HBCD exceeds the COC or hazards effect concentration (terrestrial organisms only), resulting from acute or chronic exposures.

4.1.4.1 Risk Characterization for Aquatic and Terrestrial Ecosystems based on Environmental Monitoring Data

As seen in Table 4-3 and Table 4-4, acute, algae and chronic risk quotients based on measured concentrations of HBCD near industrial facilities are equal to or greater than one, suggesting that although these surface water and sediment HBCD concentrations are not indicative of a specific exposure scenario or condition of use, there is concern regarding the potential additional release of HBCD from industrial facilities. In addition, generally both the use of the mean of mean and average of the 90th percentile measured surface water and sediment HBCD concentrations from environmental monitoring studies yielded RQs equal to or greater than one. On the other hand, RQs based of measured surface water and sediment concentrations of HBCD in sites unassociated with an industrial facility are all at least one magnitude below one. HBCD may not be bioavailable for even benthic organisms downstream of industrial facilities. HBCD is expected to have higher binding affinity for sediment and organic matter and will partition out of the water column quickly. HBCD was undetectable in sediment samples 60 km downstream of industrial facilities ([Guerra et al. 2009](#)), suggesting that it is unlikely for aquatic organisms that do not inhabit areas within close proximity to industrial facilities to be at risk for HBCD exposure.

Similarly, as depicted in Table 4-6, the calculated RQs based on measured HBCD soil concentrations are all more than one magnitude below one, using the earthworm chronic hazard effect concentrations; there is not predicted risk for soil-dwelling organisms either near industrial facilities or sites associated with the general population. In regard to terrestrial vegetation, there were no hazard data available regarding vegetation exposure to HBCD via soil. On the other hand, a reduction in root and shoot growth was observed when maize was exposed to 2 µg HBCD/L; there are no measured surface water concentrations of HBCD that exceeds 2 µg HBCD/L for either near sites categorized as being associated with an industrial facility or near general populations.

As stated in Section 4.1.2, the goal of environmental risk characterization is to determine whether there are risks to the aquatic or terrestrial environments from measured levels of HBCD found in surface water, sediment or soil. The risk quotients (RQ) method ([U.S. EPA, 1998a](#); [Barnthouse et al., 1982](#)) was used to determine whether the exposures of HBCD exceed either the concentrations of concern (COC) or hazard effects concentrations for aquatic or terrestrial organisms, respectively. Regarding terrestrial organisms, the risk is not as easily characterized because the available hazard and exposure data are not completely compatible (*i.e.*, the exposure media and corresponding units do not always match those used in predictive models or reporting methods used to collect environmental monitoring or biomonitoring data). Specifically, the terrestrial plants with data (regarding HBCD exposure) are all agricultural crops and were exposed to HBCD using exposure solutions with dissolved HBCD; the most relevant exposure pathway for HBCD to agricultural crops would be via the application of biosolids. Therefore, a RQ cannot be calculated to determine whether the exposure concentration is above the threshold where toxicological effects are observed due to biosolid application. Using the soil environmental monitoring data as presented in Table 4-6 the risk of HBCD to soil invertebrates can be evaluated by using the earthworm hazard effect concentration (56-d GMATC of 173,000 µg/kg). There are no RQs greater than one using the highest soil concentrations across the data sources presented, suggesting that terrestrial invertebrates will not be exposed to HBCD concentrations that exceed the exposure concentrations where toxicological effects were observed. As presented in Table 4-6, using

EPA methodology outlined in Section 2.3.3, a soil concentration of 41 µg/kg was calculated, with biosolid application contributing approximately 75% of the combined HBCD soil concentration, as compared to air deposition or background levels. Using either environmental monitoring, modeled or a combination of both types of data regarding soil HBCD resulted in RQs below one, further supporting the unlikelihood that soil organisms such as earthworms will be exposed to concentrations of HBCD that will exceed the threshold of hazard.

As a PBT chemical, considering the potential for chronic exposures to HBCD due to all sources (*i.e.*, water releases, air deposition, biosolid application and background levels) is imperative because evaluating any one release or exposure pathway for HBCD may underestimate HBCD exposure. Specifically, evaluating air deposition alone may imply that there isn't risk to terrestrial organisms that do not inhabit areas near industrial facilities (accounting for multiple conditions of uses). Measured soil concentrations of HBCD associated with either industrial facilities or general populations, biosolid application or background levels are greater than those predicted for specific exposure scenarios using the IIOAC. For example, the highest predicted soil HBCD concentration (via air deposition) is 0.134 µg/kg for the exposure scenario "Processing: Manufacturing EPS Foam from Imported EPS Resin beads" from fugitive stacks, which is four and one magnitude less than the amounts of HBCD measured near sites associated with industrial facilities and general population, respectively. This suggests that there is risk to soil organisms even without the additional HBCD releases via specific exposure scenarios and conditions of use and that predicted risk to soil organisms via air deposition is greatly underestimated by the use of modeled releases alone.

Land disposal of other formulated products and articles (e.g., adhesives, coatings, textiles, and electronics) (Exposure scenario characterized using solely monitoring data as a proxy)

As explained in Section 2.2, EPA did not assess a range of daily release rates based on data pertaining to emission factors and number of days of release per year. There is uncertainty regarding the extent to which these emission factors and number of days of release per year are applicable to the land disposal of formulated products and articles such as adhesives, coatings, textiles and electronics that would occur in the U.S. Releases of HBCD to the aquatic and terrestrial environment are likely to occur via this exposure scenario. The above explanation regarding the use of background information to support the predicted modeling of media-specific HBCD concentrations, apply to all conditions of use and historic uses, however as explained above in Section 4.1.3, in lieu of having modeled surface water, sediment and soil (via air deposition) HBCD concentrations for this exposure scenario, background concentrations are used to characterize the risk to aquatic and terrestrial soil organisms. In short, RQs are greater than one based on algae, acute and chronic hazard thresholds (COCs) near industrial facilities, using measured surface water concentrations (Table 4-3). Likewise, using measured sediment concentrations of HBCD near industrial facilities, RQs are greater than one based on the chronic hazard threshold for benthic invertebrates (Table 4-4). Although background concentrations of HBCD encompass HBCD releases from both historical and current conditions of use, there may be risk to aquatic organisms that inhabit water bodies near facilities associated with the disposal of adhesives, coatings, textiles, and electronics due to leaching and runoff. There are no measured soil concentrations due to air deposition that result in risk to soil organisms, based on the chronic hazard threshold for earthworms.

4.1.4.2 Risk Characterization for Aquatic and Terrestrial Ecosystems based on Modeled Surface Water and Sediment Concentrations

To evaluate the risk for organisms in aquatic ecosystems due to of HBCD exposure, modeled surface water concentrations were compared to concentrations of concern (COC) based on acute, algae, and chronic hazard effect concentrations, and modeled sediment concentrations were compared to a chronic hazard effect concentration. The exposure scenarios are labeled with an exposure scenario number to

help orient the audience as the exposure scenarios do not necessarily follow the same order when categorized by their condition of use (as seen in Section 4.5).

The risk quotients (RQ) for every exposure sub-scenario are available in Appendix J.1.2, based on both the 10th and 50th percentile surface water and pore water concentrations of HBCD. The risk characterization for aquatic organisms is based on RQs derived from predicted surface water and sediment concentrations for production volumes of 100,000 lbs/yr and 0% removal of HBCD from directly released HBCD into surface water.

Additionally, a targeted sensitivity analysis was conducted to characterize how two additional production volumes for three exposure scenarios (derived from the 10th and 50th percentile surface water and sediment HBCD concentrations) may affect derived RQs for aquatic organisms. Using the predicted surface water and pore water HBCD concentrations from the PSC, and proxy organism hazard data (*i.e.*, rats and Japanese quail) as input parameters for KABAM (v1), RQs for multiple mammalian wildlife species can be estimated (assuming that the effect concentrations are the same as those as the proxy organism by scaling of body weight).

Repackaging of Import Containers (Exposure scenario 1)

Section 2.2 of this document describes how HBCD is processed at industrial sites specifically for repackaging of import containers. This process can result in direct releases of HBCD into surface water, or release through POTWs.

For each release medium, EPA assessed a range of daily release rates based on data pertaining to emission factors and number of days of release per year. The emission factors were obtained from the OECD ESD on Plastics Additives ([OECD 2009](#)). The number of days of release per year are estimated values that are applicable to the basic chemical industry in general ([ECB 2003](#)). There is some uncertainty regarding the extent to which these emission factors and number of days of release per year are applicable to the repackaging of import containers that would occur in the U.S. Releases of HBCD to the aquatic environment are due to the activity of repackaging of import containers.

Within this exposure scenario, there are eight exposure sub-scenarios with predicted surface water and sediment HBCD concentrations. Based on the predicted 50th percentile surface water HBCD concentrations, there are three acute and algae and two chronic risk estimates that are greater than one, based on the acute, algae and chronic COCs of 0.4, 1.0 and 0.417 µg/L, respectively. Based on the predicted 10th percentile surface water HBCD concentrations, all eight exposure sub-scenarios have RQs greater than one, based off of the acute, algae and chronic COCs.

In evaluating the 50th percentile predictions to calculate RQs for benthic organisms, there are two RQs greater than one using the 128-d HBCD half-life; none of the RQs based on the 11-d HBCD half-life resulted in RQs equal to or greater than one. Based on the predicted 10th percentile sediment HBCD concentrations, all eight of the RQs based on the 128-d HBCD half-life had RQs greater than one. Based on the predicted 10th percentile sediment HBCD concentrations, half of the RQs were greater than one, using the 11-d HBCD half-life; the other four RQs were within approximately 10% of a RQ of 1, demonstrating that the predicted releases based on the less conservative half-life of 11-d exceeds or are very close to reaching the reproductive hazard threshold for *L. variegatus* ([Oetken et al. 2001](#)).

Compounding of Polystyrene Resin to Produce XPS Masterbatch (Exposure scenario 2)

Section 2.2 of this document describes how HBCD is processed at industrial sites specifically for compounding polystyrene resin to produce XPS Masterbatch. This process can result in direct releases of HBCD into surface water, or release through POTWs and onsite wastewater treatment.

For each release medium, EPA assessed a range of daily release rates based on data pertaining to emission factors and number of days of release per year. The emission factors pertain to sites in Europe at which XPS Masterbatch was compounded ([ECHA 2008b](#)). The data pertaining to the number of release days per year are estimated values that are applicable to the polymer formulation industry in general ([ECB 2003](#)). There is some uncertainty regarding the extent to which these emission factors and number of days of release per year are applicable to the compounding of XPS Masterbatch that would occur in the U.S. Releases of HBCD to the aquatic environment are due to the activity of compounding polystyrene resin to produce masterbatches of XPS.

Within this exposure scenario, there are twelve exposure sub-scenarios with predicted surface water and sediment HBCD concentrations. Based on the predicted 50th percentile surface water concentrations of HBCD, there are only two RQs greater than one when using the fish acute COC of 0.4 µg/L ([Hu et al. 2009a](#)). Based on the predicted 10th percentile surface water concentrations of HBCD, eight out of twelve exposure sub-scenarios have RQs greater than one when using the fish acute and algae COCs, and four of those twelve have RQs greater than one when using the chronic COC based on water flea reproductive hazard effect concentration ([Drottar and Krueger 1998](#)).

In regard to the predicted sediment HBCD concentrations, there are only two RQs that are equal to or greater than one for predicted sediment concentrations, and both were calculated using the 10th percentile prediction based on the longer 128-d HBCD half-life.

Manufacturing of XPS Foam using XPS Masterbatch (Exposure scenario 3)

Section 2.2 of this document describes how HBCD is processed at industrial sites specifically for manufacturing of XPS foam using XPS Masterbatch. This process can result in direct releases of HBCD into surface water, or release through POTWs and onsite wastewater treatment.

For each release medium, EPA assessed a range of daily release rates based on data pertaining to emission factors and number of days of release per year. These emission factors and number of days of release per year pertain to sites in Europe at which XPS Foam was manufactured ([ECHA 2008b](#)). There is some uncertainty regarding the extent to which these emission factors and number of days of release per year are applicable to the manufacture of XPS from Masterbatch that would occur in the U.S. Releases of HBCD to the aquatic environment are due to the activity of manufacturing of XPS foam using XPS Masterbatch.

Within this exposure scenario, there are 12 exposure sub-scenarios with predicted surface water and sediment HBCD concentrations. Based on the predicted 50th percentile surface water concentrations, there are no RQs greater than one for chronic hazard, but there are four and three RQs that exceed the threshold for risk for the acute and algae COCs, respectively. Based on the predicted 10th percentile surface water concentrations, there are 10, eight and five RQs that are greater than one, when using the acute, algae and chronic COCs, respectively.

Based on the 50th percentile predictions for sediment HBCD concentrations, there were no instances of risk estimates greater than one (indicating risk) using either the 11- or 128-d half-lives of HBCD. Based

on the predicted 10th percentile sediment HBCD concentrations, there are one and two RQs that exceed the sediment COC, using the 11- or 128-d HBCD half-life, respectively.

Processing of HBCD to produce XPS Foam using HBCD Powder (Exposure scenario 4)

Section 2.2 of this document describes how HBCD is processed at industrial sites specifically for manufacturing of XPS foam using XPS powder. This process can result in direct releases of HBCD into surface water, or release through POTWs and onsite wastewater treatment.

For each release medium, EPA assessed a range of daily release rates based on TRI data and data pertaining to emission factors and number of days of release per year. These emission factors in general and number of days of release per year in the case of releases to water pertain to sites in Europe at which XPS Foam was manufactured ([ECHA 2008b](#)). In the case of releases to air, the data pertaining to the number of release days are estimated values that are applicable to the industrial use of polymers in general ([ECB 2003](#)). There is some uncertainty regarding the extent to which these emission factors and number of days of release per year are applicable to the manufacture of XPS from HBCD that would occur in the U.S. Releases of HBCD to the aquatic environment are due to the activity of manufacturing XPS foam using HBCD powder.

Within this exposure scenario, there are six exposure sub-scenarios with predicted surface water and sediment HBCD concentrations. Based on the predicted 50th percentile surface water HBCD concentrations, there are no RQs greater than one using the chronic COC. However, based on the algae and acute COC, there is one and two RQs greater than one, respectively. Based on the predicted 10th percentile surface water HBCD concentrations, there is one RQ greater than one when using the chronic COC, and four RQs that are greater than one when using either the acute or algae COC. Additionally, of the six exposure sub-scenarios, the two RQs based on the acute COC that are less than one have surface water concentrations that are within 10% of exceeding the acute COC, suggesting that all six acute RQs either exceed or within the same magnitude of the zebrafish hazard effect concentration ([Hu et al. 2009a](#)).

In regard to sediment HBCD concentrations modeled using the PSC, there is only one risk estimate greater than one, using the 10th percentile predictions based on the 128-d HBCD half-life, suggesting that the water releases of HBCD from this exposure scenario will not result in sediment concentrations of HBCD that will surpass the sediment COC.

Processing of HBCD to produce EPS Foam from Imported EPS Resin Beads (Exposure scenario 5)

Section 2.2 of this document describes how HBCD is processed at industrial sites specifically for manufacturing of EPS foam imported EPS Resin Beads. This process can result in direct releases of HBCD into surface water, or release through POTWs and onsite wastewater treatment.

For each release medium, EPA assessed a range of daily release rates based on data pertaining to emission factors and number of days of release per year. The emission factors were obtained from the OECD ESD on Plastics Additives ([OECD 2009](#)) or an EPA/OPPT screening-level model. The number of days of release per year is an estimated value that is applicable to the industrial use of polymers in general or is a value that pertains to the manufacture of EPS foam at a site in Australia ([NICNAS, 2012b](#)). There is some uncertainty regarding the extent to which these emission factors and number of days of release per year are applicable to the manufacture of EPS foam that would occur in the U.S. Furthermore, EPA's assessment of releases may be conservative based on a comparison of sources of release and emission factors as assessed by EPA and as reported in EURAR and NICNAS ([NICNAS](#)

[2012b](#); [ECHA 2008b](#)) for this exposure scenario. Releases of HBCD to the aquatic environment are due to the activity of the processing of EPS foam from imported EPS resin beads.

Within this exposure scenario, there are 12 exposure sub-scenarios with predicted surface water and sediment HBCD concentrations. Based on the 50th percentile surface water concentration predictions, a majority of the RQs are greater than one, with 12, 11 and nine RQs greater than one when using the acute, algae and chronic COCs, respectively. Based on the 10th percentile surface water concentration predictions, all of the exposure sub-scenarios have RQs greater than one based on the acute, algae and chronic COCs.

The 50th percentile sediment HBCD concentration predictions resulted in eight RQs greater than one using either the 11- or 128-d HBCD half-lives. Based on the 10th percentile sediment HBCD concentration predictions, all 12 RQs are greater than one using either the 11- or 128-d HBCD half-lives.

Processing of HBCD to produce SIPs and Automobile Replacement Parts from XPS/EPS Foam (Exposure scenario 6)

Section 2.2 of this document describes how HBCD is processed at industrial sites specifically for manufacturing of structural insulated panels and automobile replacement parts from XPS/EPS foam. This process can result in direct releases of HBCD into surface water, or release through POTWs and onsite wastewater treatment.

EPA assessed a range of daily release rates based on data pertaining to particle generation from the cutting or sawing of XPS/EPS foam reported in the EURAR ([ECHA 2008b](#)) and disposal of trimming waste given in the Spray Polyurethane Foam Generic Scenario ([U.S. EPA 2018d](#)). The data pertaining to the number of release days are estimated values that are applicable to the polymer use industry in general ([ECB 2003](#)). There is some uncertainty regarding the extent to which the emission factor data reported in the EURAR and the data on the number of release days are applicable to these specific exposure scenario activities that would occur in the U.S. Releases of HBCD to the aquatic environment are due to the activity of manufacturing of structural insulated panels and automobile replacement parts from XPS/EPS foam.

Within this exposure scenario, there are 12 exposure sub-scenarios with predicted surface water and sediment HBCD concentrations. Based on the 50th percentile surface water concentration predictions, there are no RQs that are greater than one, using the chronic COC, but there are two and one acute and algae RQ, respectively, that exceed one. Based on the 10th percentile surface water concentration predictions, there are eight, seven and four RQs that are greater than one, using the acute, algae and chronic COCs.

Based on the 50th percentile sediment concentration predictions, there are no RQs greater than one, using either the 11- or 128-d HBCD half-lives. On the other hand, based on the 10th percentile sediment concentration predictions, there are two and four RQs that exceed the sediment COC using 11- or 128-d HBCD half-lives, respectively.

Installation of XPS/EPS Foam Insulation in Residential, Public, and Commercial Buildings, and Other Structures (Exposure scenario 8)

Section 2.2 of this document describes how HBCD is processed at industrial sites specifically for the installation of XPS/EPS foam insulation in residential, public, and commercial buildings (and other

structures). This process can result in direct releases of HBCD into surface water, or release through POTWs.

EPA assessed a range of daily release rates based on an estimated HBCD throughput at residential and commercial buildings, emission data pertaining to particle generation from the cutting or sawing of XPS/EPS foam reported in the EURAR ([ECHA 2008b](#)) and disposal of trimming waste given in the Spray Polyurethane Foam Generic Scenario ([U.S. EPA 2018d](#)). The data pertaining to the number of release days are estimated values given in the Spray Polyurethane Foam (SPF) Generic Scenario for operating days at construction sites. There is some uncertainty regarding the extent to which the emission factor data reported in the EURAR and installation days for SPF are applicable to this specific exposure scenario that would occur in the U.S. Releases of HBCD to the aquatic environment are due to the activity of installation of XPS/EPS foam insulation in residential, public and commercial buildings (and other structures).

Within this exposure scenario, there are four exposure sub-scenarios with predicted surface water and sediment HBCD concentrations. Based on the 50th percentile surface water concentration predictions, there are no RQs that are greater than one, when using the chronic COC, but there is one RQ greater than one, when using either the acute or algae COC. Based on the 10th percentile surface water concentration predictions, there is one RQ greater than one, when using the chronic COC, and two RQs greater than one when using either the acute or algae COC.

In regard to the predicted sediment HBCD concentrations, there are no RQs greater than one based off of the 50th percentile sediment concentrations, using either the 11- or 128-d HBCD half-life, whereas there is one RQ greater than one based off of the 10th percentile sediment concentration prediction when using the 128-d half-life.

Demolition and Disposal of XPS/EPS Foam Insulation Products in Residential, Public and Commercial Buildings, and Other Structures (Exposure scenario 9)

Section 2.2 of this document describes how EPA estimated releases from sites at which structures containing XPS/EPS foam insulation are demolished. This activity can result in releases of HBCD to air, surface water, and/or POTWs.

EPA assessed a range of daily release rates based on particle generation factors pertaining to the manual breaking of XPS/EPS foam boards and the cutting of XPS/EPS foam boards with a knife followed by manual breaking.

Within this exposure scenario, there are four exposure sub-scenarios with predicted surface water and sediment HBCD concentrations. Based on the 50th percentile surface water concentration predictions, there are no RQs that are greater than one, when using the chronic COC, but there is one RQ greater than one, when using either the acute or algae COC. Based on the 10th percentile surface water concentration predictions, there is one RQ greater than one, when using the chronic COC, and two RQs greater than one when using either the acute or algae COC.

In regard to the predicted sediment HBCD concentrations, there are no RQs greater than one based off of either the 10th or 50th percentile sediment concentrations, using either the 11- or 128-d HBCD half-life.

Recycling of EPS Foam and Reuse of XPS Foam (Exposure scenario 10)

Section 2.2 of this document describes how EPA estimated releases from sites at which HBCD is processed for the industrial recycling of EPS foam and the reuse of XPS foam. This process can result in direct releases of HBCD into surface water, or release through POTWs and onsite wastewater treatment.

EPA assessed a range of daily release rates based on the emission data like the Manufacturing of EPS foam from EPS resins as stated earlier in this section with the exclusion of releases from trimming waste. There is some uncertainty regarding the extent to which the emission factor data and the data on number of release days are applicable to this specific exposure scenario. Releases of HBCD to the aquatic environment are due to the activity of the recycling of EPS foam and reuse of XPS foam.

Within this exposure scenario, there are 12 exposure sub-scenarios with predicted surface water and sediment HBCD concentrations. Based on the 50th percentile surface water concentration predictions, there are no RQs that are greater than one, when using the chronic COC, but there are four and two RQs greater than one when using the acute or algae COC, respectively. Based on the 10th percentile surface water concentration predictions, there are eight, six and two RQs greater than one, when using the acute, algae and chronic COC, respectively.

Regarding the predicted sediment HBCD concentrations, there are no RQs greater than one based off the 50th percentile sediment concentrations, using either the 11- or 128-d HBCD half-life, whereas there are two RQs greater than one based on the 10th percentile sediment concentration predictions, using either the 11- or 128-d HBCD half-life.

Use of Solder/Flux Pastes (Exposure scenario 12)

Section 2.2 of this document describes how HBCD is processed at industrial sites specifically for the use of solder or flux pastes. This process can result in the release of HBCD through POTWs and onsite wastewater treatment.

EPA assessed a range of daily release rates based on estimated emissions from the use of solder paste reported in the OECD ESD on Chemicals Used in the Electronics Industry ([OECD 2010a](#)). The data pertaining to the number of release days are estimated values that are applicable to the electronics industry in general ([ECB 2003](#)). There is some uncertainty regarding the extent to which the emission factor data reported in general for solder paste use in the ESD and the data on number of release days are applicable to the current use of HBCD-containing flux/solder paste. Releases of HBCD to the aquatic environment are due to the activity of the use of solder or flux pastes.

Within this exposure scenario, there are eight exposure sub-scenarios with predicted surface water and sediment HBCD concentrations. Based on the 50th percentile surface water concentration predictions, there are no RQs greater than one, whereas there are two RQs greater than one based on the 10th percentile surface water concentration predictions using the acute COC.

All risk estimates are less than one when using the 10th or 50th percentile predictions for sediment concentrations of HBCD, using either the 11- or 128-d HBCD half-life.

4.1.4.3 Risk Characterization for Aquatic and Terrestrial Ecosystems based on Exposure via Potential Trophic Transfer of HBCD

As presented in Section 3.1.3, the trophic transfer potential of HBCD is evaluated for a representative terrestrial and aquatic predator; the potential risk to terrestrial and aquatic organisms can be qualitatively evaluated using this methodology. Table 4-8 presents the RQs based on the hazard value for American kestrel ([Fernie et al. 2011](#)) and measured biomonitoring data regarding the prey of American kestrel and

osprey. Specifically in regard to American kestrel, reproductive toxicity was observed in female kestrel exposed to 0.51 mg/kg bw (Fernie et al. 2011). Table 3-2 suggests that American kestrel are exposed to 64.4 ng HBCD per day through the consumption of small mammals (*i.e.*, mice), however mice only comprise approximately a third of American kestrel diet; it is likely that these calculations underestimate HBCD uptake through diet. On the other hand, because osprey diet is 100% characterized by the consumption of fish, a variety of T2 and T3 fish biomonitoring data (rainbow trout, northern snakehead, brown trout, eel) were used to examine whether osprey could consume enough fish to be exposed to concentrations of HBCD that would exceed the allometrically-scaled kestrel reproductive hazard effect concentration (Fernie et al. 2011). RQs for osprey were only greater than one when their diet comprised of brown trout and eel that were sampled downstream of HBCD manufacturing plants, demonstrating that prey type and availability, as well as their proximity to areas with higher concentrations of HBCD in environmental media (*i.e.*, industrial facilities) will be important variables to consider when characterizing exposure.

RQs presented in Table 4-9 suggest that in addition to the high likelihood for HBCD to bioconcentrate in rainbow trout and earthworms, through both diet and media exposure, HBCD will exceed thresholds of hazard, respectively. The PBT characteristics of HBCD also may result in changes in population-level dynamics in aquatic and terrestrial ecosystems should organisms similar to rainbow trout and earthworms be chronically exposed to HBCD.

Using predicted surface water and porewater HBCD concentrations, risk quotients for terrestrial mammals were calculated using KABAM (v1); risk quotients for terrestrial birds could not be calculated due to hazard data incapability with model outputs. Although the risk estimates for soil organisms (*i.e.*, earthworms) are less than one, the potential for both dietary and environmental exposure to HBCD is likely; exposure to HBCD is prolonged given the PBT characteristics of HBCD. Conflicting risk estimates for earthworms using IIOAC modeled air deposition HBCD concentrations or laboratory measured bioconcentration data suggest that the release of HBCD through exposure-specific scenarios may not result in additional risk. However, current background soil concentrations of HBCD, without the potential releases of HBCD from the various modeled exposure scenarios, already pose a risk to earthworms, and potentially other terrestrial organisms, near industrial facilities or potentially receive biosolid application from areas downstream of industrial facilities areas with high concentrations of HBCD.

4.1.4.4 Targeted Sensitivity Analysis

Section 2.2.14 describes the context behind conducting a targeted sensitivity analysis based on production volume. Briefly, due to the uncertainty with the imported volume and resulted estimates of environmental releases and exposures to the general population and the environment, a targeted sensitivity analysis on the impact of import volumes on environmental risk estimates is conducted in this section. The exposure scenarios considered in the sensitivity analysis represent those that resulted in the highest estimates of releases on a daily basis and include scenarios that rely on both industry data and OECD ESDs. Specifically, those exposure scenarios are listed below with their respective discussions on risk estimates for surface water and sediment concentrations of HBCD.

Originally as presented above in Section 4.1.4.2, all nine exposure scenarios with estimated water releases containing HBCD were predicted to have production volumes up to 100,000 lbs/yr. The purpose of the sensitivity analysis is to evaluate how the model input parameter of production volume may impact the predicted surface water and sediment HBCD concentrations. In addition to deriving risk quotients by using predicted surface water and sediment HBCD concentrations based on a production volume of 100,000 lbs/yr, risk quotients were also derived using the production volumes of 50,000 and

25,000 lbs/yr for the three processing exposure scenarios: exposure scenario #1: Repackaging of import containers, exposure scenario #2: Manufacturing of XPS Foam using XPS Masterbatch, and exposure scenario #3: Manufacturing of EPS Foam from Imported EPS Resin Beads. Unlike exposure scenarios 3 and 5, exposure scenario 1 (Repackaging of Import Containers) does not have direct releases into surface water, therefore resulting in less total exposure scenarios. As stated above, the same sources of information regarding the range of daily release rates, emission factors, number of release days per year, and surrounding uncertainties outlined for each exposure scenario apply to the same exposure scenarios (1, 3, and 5) below.

For two processing exposure scenarios (Manufacturing of XPS Foam using XPS Masterbatch, and Manufacturing of EPS Foam from Imported EPS Resin Beads), risk quotients were also calculated based on predicted surface and pore water HBCD concentrations for terrestrial avian and mammalian wildlife. Specifically, two model sub-scenarios for these exposure scenarios (3.3 and 5.7) were selected because despite both having predicted direct releases of HBCD into surface water, the water releases vary greatly, with model sub-scenario 5.7 having greater HBCD surface water, pore water and sediment concentrations than 3.3. These sub-scenarios were selected to provide a range in risk estimates that reflect lower and higher water releases of HBCD. The purpose of using KABAM was to estimate HBCD risk to terrestrial organisms that prey on aquatic wildlife.

4.1.4.4.1 Summary of Ranges of RQs: Production Volume

The below table provides a range of risk quotients (RQ) that were calculated using predicted surface water or sediment concentrations for three exposure scenarios: Repackaging of Import Containers, Processing of HBCD to produce XPS Foam using XPS Masterbatch, and Processing of HBCD to produce EPS Foam from Imported EPS Resin Beads (Section 2.2.15). The sensitivity analysis evaluates the impact of production volume on RQ values. However, amongst the exposure sub-scenarios, altering the production volume only impacted the percentage of RQs to be equal to or greater than one, when using surface water or sediment concentrations based off the 50th percentile predictions.

Table 4-10. Range of Risk Quotients for Modeled Surface Water and Sediment HBCD Concentrations for Three Conditions of Use Scenarios Using a Production Volume of 100,000, 50,000, and 25,000 lbs/yr

The bolded and red highlighted values denote when half or more of the sub-scenario risk quotients (RQ) modeled for each exposure scenario are ≥ 1 . If the predicted surface water or sediment concentration was 0, or if the calculated RQ was < 0.005 , the RQ was rounded to 0.											
Exposure Scenario	Production Volume (lbs / year)	Surface Water						Sediment			
		Acute		Algae		Chronic		11-d half-life		128-d half-life	
		10 th percentile	50 th percentile	10 th percentile	50 th percentile	10 th percentile	50 th percentile	10 th percentile	50 th percentile	10 th percentile	50 th percentile
Repackaging of Import Containers (1)	100,000	4.3-189	0.09-24.2	1.72-75.6	0.04-9.68	3.5-21.22	0.07-2.26	0.87-4.61	0.02-0.56	2.29-11.91	0.05-1.26
	50,000	3.93-180.5	0.09-23.38	1.57-72.2	0.04-9.35	1.99-11.44	0.04-1.21	0.48-2.85	0.01-0.34	1.23-7.45	0.03-0.79
	25,000	3.65-192.25	0.09-10	1.46-76.9	0.04-10	0.97-10	0.02-1.16	0.22-1.68	0.01-0.21	0.57-3.66	0.01-0.4
Processing of HBCD to produce XPS Foam using XPS Masterbatch (3)	100,000	0.76-275	0.01-7.33	0.3-110	0.01-2.97	0.04-13.5	0.001-0.33	0.01-2.22	0-0.06	0.02-2.97	0-0.08
	50,000	0.38-138.5	0.01-3.7	0.15-55.4	0-1.48	0.02-6.81	0-0.17	0.01-1.12	0-0.03	0.01-1.5	0-0.04
	25,000	0.19-69.25	0-1.85	0.08-27.7	0-0.74	0-3.41	0-0.08	0-0.56	0-0.1	0.01-0.75	0-0.02
Processing of HBCD to produce EPS Foam from Imported EPS Resin Beads (5)	100,000	89.5-9,900	2.2-262.5	35.8-3,960	0.88-105	33.57-563.55	0.70-12	8.73-143.31	0.21-3.52	22.68-361.78	0.48-7.77
	50,000	44.75-9850	1.10-262.50	17.9-3940	0.44-105	16.76-515.59	0.35-12	4.36-89.17	0.11-2.23	11.34-201.27	0.24-4.39
	25,000	18.23-9825	0.55-262.5	7.29-3930	0.22-105	4.46-491.61	0.18-12	1.15-79.62	0.05-2.03	3-135.03	0.12-3.13

Repackaging of Import Containers (Exposure scenario 1)

Surface Water:

Whether the 10th or 50th percentile surface water concentrations of HBCD were used, there are risk quotients (RQs) greater than one using the acute, algae and chronic COCs for all three production volumes. Based on the 10th percentile surface water HBCD concentrations, at least half of the RQs are greater than one, using the acute, algae and chronic COC, regardless of the production volume. Based on the 50th percentile surface water HBCD concentrations, at least half of the RQs are greater than one, using the acute COC for all three production volumes.

Sediment:

Similar to the predicted surface water HBCD concentrations, based on the 10th percentile sediment concentrations of HBCD, the sediment chronic RQs are greater than one using both the 11- and 128-d HBCD half-lives. In regard to the 50th percentile sediment concentrations of HBCD, there are only RQs greater than one based on the 128-d HBCD half-life, using a production volume of 100,000 lbs/yr.

Processing of HBCD to produce XPS Foam using XPS Masterbatch (Exposure scenario 3)

Surface Water:

For all three production volumes, based on the 10th percentile surface water concentrations of HBCD were used, there are risk quotients (RQs) greater than one using the acute, algae and chronic COCs for all three production volumes. Specifically, over half of the derived RQs are greater than one using the 10th percentile surface water concentrations of HBCD, based on the acute and algae COCs for all three production volumes; over half of the chronic RQs are greater than one using the production volume of 100,000 lbs/yr. Based on the 50th percentile surface water HBCD concentrations, there are RQs greater than one for all three production volumes, using the acute COC, whereas RQs are only greater than one for both 100,000 and 50,000 lbs/yr, when using the algae COC. There are no RQs greater than one based on the 50th percentile surface water concentrations of HBCD, when using the chronic COC.

Sediment:

There are RQs greater than one, when using the 10th percentile sediment concentrations of HBCD and either 11- or 128-d HBCD half-lives, for production volumes of 100,000 and 50,000 lbs/yr (there were no RQs greater than one for the lowest production volume of 25,000 lbs/yr). Based on the 50th percentile sediment concentrations of HBCD, there were no RQs greater than one using either HBCD half-lives for any of the three production volumes.

Risk Estimates for Terrestrial Organisms (KABAM outputs):

For all three production volumes, based on the 50th percentile surface water and sediment concentrations, there are no instances of risk estimates greater than one (indicating risk) for small and large mink and small river otters. See Appendix 0. Estimates for terrestrial organisms were not modeled using the 10th percentile surface water and sediment concentrations, but it is likely that there may be risk estimates greater than one using more conservative media concentrations.

Processing of HBCD to produce EPS Foam from Imported EPS Resin Beads (Exposure scenario 5)

Surface Water:

Whether the 10th or 50th percentile surface water concentrations of HBCD were used, there are risk quotients (RQs) greater than one using the acute, algae and chronic COCs for all three production volumes. Additionally, regardless of the production volume or whether the 10th or 50th percentile surface water concentrations of HBCD were used, more than half of the calculated RQs for this exposure scenario have RQs greater than one.

Sediment:

Similarly, whether the 10th or 50th percentile sediment concentrations of HBCD were used, there are RQs greater than one using either HBCD half-lives, for all three production volumes. Based on the either half-lives, at least half of the calculated RQs are greater than one for all three production volumes, using the 10th percentile sediment concentrations of HBCD. Based on the 50th percentile sediment concentrations of HBCD, at least half of the calculated RQs are greater than one for all three production volumes, using the 128-d HBCD half-life, whereas this is only the case for the production volume of 100,000 lbs/yr, using the 11-d HBCD half-life.

Risk Estimates for Terrestrial Organisms:

For all three production volumes, based on the 50th percentile surface water and sediment concentrations, there are risk estimates greater than one for small and large mink, and small river otters (nine out of 15 risk estimates). See Appendix J.1.2.3.

4.2 Human Health Risk

4.2.1 Risk Estimation Approach

The use scenarios, populations of interest and toxicological endpoints used for acute and chronic exposures are presented in Table 4-11.

Table 4-11. Use Scenarios, Populations of Interest and Toxicological Endpoints Used for Acute and Chronic Exposures

<p>Population of Interest and Exposure Scenario</p>	<p>Workers: <u>Acute</u>- Adult workers (≥ 21 years old) and female workers of reproductive age (≥ 16 year to less than 50 years old) exposed to HBCD for a single 8-hr exposure <u>Chronic</u>- Adult workers (≥ 21 years old) and female workers of reproductive age (≥ 16 year to less than 50 years old) exposed to HBCD for the entire 8-hr workday for 260 days per year for 40 working years</p> <p>Occupational Non-User: <u>Acute or Chronic</u>- Adult workers (≥ 21 years old) and female workers of reproductive age (≥ 16 year to less than 50 years old) exposed to HBCD indirectly by being in the same work area of the building</p> <p>General Population (Background Exposure): <u>Acute or Chronic</u> - <1 year, 1 to <2 years, 2 to <3 years, 3 to <6 years, 6 to <11 years, 11 to <16 years, 16 to <70 years</p> <p>Highly Exposed Population (Near-Facility, Consumers): <u>Acute or Chronic</u> - <1 year, 1 to <2 years, 2 to <3 years, 3 to <6 years, 6 to <11 years, 11 to <16 years, 16 to <70 years</p>
<p>Health Effects, Concentration and Time Duration</p>	<p>Units for Non-Cancer Point of Departures (POD): mg/kg-day</p> <p>Non-Cancer Health Effects: ² <u>Acute</u>- Thyroid hormone effects and developmental effects <u>Chronic</u>- Thyroid hormone effects, liver effects, reproductive effects, and developmental effects</p>
<p>Uncertainty Factors (UF) used in Non-Cancer Margin of Exposure (MOE) calculations</p>	<p>Benchmark MOEs: Vary by endpoint</p> <p>Benchmark MOE ³ = (UF_S) x (UF_A) x (UF_H) x (UF_L)</p>
<p>¹Adult workers (>21 years old) include both female and male workers. ²Female workers of reproductive age (>16 to less than 50 years old) are the population of interest for reproductive and developmental effects because 16 is the basic minimum age for employment (https://www.dol.gov/agencies/whd/fact-sheets/43-child-labor-non-agriculture) and 50 is average age of menopause. For other health effects (e.g., liver, kidney, etc.), female or male workers were assumed to be the population of interest. Estimation of the risk was calculated for each group based on differences in body weight as described in the Exposure Factors Handbook (U.S. EPA 2011b). ³ UF_S=subchronic to chronic UF; UF_A=interspecies UF; UF_H=intraspecies UF; UF_L=LOAEL to NOAEL UF. ⁴OSHA defines chronic workplace exposures to be 8 hr-workday for 240 days for 45 years. EPA typically uses 250 days and calculated 50th (31 years) and 95th percentile (40 years) working years using data from U.S. Census Bureau (Census Bureau 2016) see Appendix E.7.</p>	

The EPA uses a Margin of Exposure (MOE) approach to assessing non-cancer risk. The MOE is the ratio of the point of departure (POD) dose divided by the human exposure dose. The MOE is compared to the benchmark MOE. The MOE estimate was interpreted as human health risk if the MOE estimate was less than the benchmark MOE (*i.e.*, the total UF). On the other hand, the MOE estimate indicated negligible concerns for adverse human health risks if the MOE estimate exceeded the benchmark MOE.

Acute or chronic MOEs (MOE_{acute} or $MOE_{chronic}$) were used in this assessment to estimate non-cancer risks using Equation 4-1.

Equation 4-1. Equation to Calculate Non-Cancer Risks Following Acute or Chronic Exposures Using Margin of Exposures

$$MOE_{acute\ or\ chronic} = \frac{\text{Non - cancer Hazard value (POD)}}{\text{Human Exposure}}$$

Where:

- MOE** = Margin of exposure (unitless)
- Hazard Value (POD)** = HED (mg/kg)
- Human Exposure** = Exposure estimate (in mg/kg) from occupational exposure assessment
= Exposure estimate (in mg/kg) from general population and highly exposed population exposure assessment

Acute Absorbed Doses (AADs) were used to calculate occupational non-cancer risks following acute exposure and Chronic Absorbed Doses (CADs) were used for occupational non-cancer risks following chronic exposure (see Section 2.4.1.1 for description). Acute Dose Rates (ADRs) were used to calculate non-cancer risks to the general population following acute exposure (see Section 2.4.2 for description and equations by media type).

EPA used margin of exposures (MOEs)²⁰ to estimate risks from acute or chronic exposures for non-cancer based on the following:

1. the lowest HEDs within each non-cancer health effects domain reported in the literature;
2. the endpoint/study-specific UFs applied to the HEDs per EPA RfD/RfC Guidance ([U.S. EPA 2002](#)); and
3. the exposure estimates calculated for HBCD uses examined in this risk assessment (see Section 3.2-Exposures).

MOEs allow for the presentation of a range of non-cancer risk estimates. The occupational exposure scenarios (OES) considered both acute and chronic exposures. As discussed in Section 2.4.1.1, inhalation exposures to occupational non-users (ONUs) were not quantified due to lack of adequate data but are expected to be less than worker exposures. Different adverse endpoints were determined to be appropriate based on the expected exposure durations. For non-cancer effects, risks for acute effects (offspring loss) were evaluated for acute (short-term) exposures, whereas risks for thyroid effects were evaluated for repeated (chronic) exposures to HBCD. EPA discusses other effects in Sections 3.2.3 and 3.2.4.

²⁰ Margin of Exposure (MOE) = (Non-cancer hazard value, POD) ÷ (Human Exposure). Equation 4-1. The benchmark MOE is used to interpret the MOEs and consists of the total UF as described in Section 3.2.5.3.

For general population (background) risks for only chronic exposure scenarios were considered because they represent a steady-state, while for highly exposed populations (living near a facility) both acute and chronic exposures were considered. Risks to the highly exposed population were associated with specific COUs and exposure scenarios, while general population exposures represented baseline steady-state exposures from persistent HBCD in environmental media. Different adverse endpoints were used based on the expected exposure durations. For non-cancer effects, risks for developmental effects were evaluated for acute (short-term) exposures, whereas risks for other adverse effects (toxicity to the thyroid, liver, developmental effects, and the female reproductive system) were evaluated for repeated (chronic) exposures to HBCD. For occupational exposure calculations, mg/kg values were used to calculate MOEs for risk estimates following acute and chronic exposures.

The total UF for each non-cancer POD was the benchmark MOE used to interpret the MOE risk estimates for each use scenario. The MOE estimate was interpreted as a potential human health risk if the MOE estimate was less than the benchmark MOE (*i.e.*, the total UF). On the other hand, the MOE estimate indicated negligible concerns for adverse human health effects if the MOE estimate exceeded the benchmark MOE. Typically, the larger the MOE, the more unlikely it is that a non-cancer adverse effect would occur.

Risk estimates in the form of MOE values were calculated for all of the studies for each health effects domain that EPA considered suitable for the Risk Evaluation of acute and chronic exposure scenarios. The studies selected for dose-response assessment and derivation of PODs examined oral administration of HBCD. These oral PODs are directly applicable to risks from oral exposures such as via soil, drinking water, and diet. For inhalation exposure, EPA considered the quantification of incidental ingestion of particulates that would result from exposure to HBCD dust in occupational, environmental, or residential settings. It is assumed that any inhaled particulate would either be absorbed through the lungs or swallowed and subsequently absorbed in the GI tract. Based on available toxicokinetic data, EPA conservatively assumes 100% absorption through the lungs and GI tract, although the majority of HBCD particles are likely to deposit in the upper respiratory tract and be ingested. EPA did not identify any respiratory-specific hazards associated with HBCD exposure. Since all HBCD hazards evaluated through dose-response analysis involve systemic toxicity, it is irrelevant for the purposes of this assessment whether HBCD is absorbed through the lungs or GI tract. Therefore, EPA used total inhalation exposure values (as opposed to only respirable) for risk estimation.

For dermal exposure, EPA performed route-to-route extrapolation from oral toxicity based on similar principles to those described in the EPA Guidance Document *Risk Assessment Guidance for Superfund Volume I: Human Health Evaluation Manual (Part E, Supplemental Guidance for Dermal Risk Assessment)* ([U.S. EPA 2004](#)). All risk calculations for dermal exposure incorporate an adjustment for 6.5% absorption, based on available toxicokinetic data (see Section 3.2.2).

4.2.1.1 Representative Points of Departure for Use in Risk Estimation

In order to more succinctly present the most important risk estimates, occupational risks were assessed using a single endpoint representative of each health domain. EPA considers all of the endpoints identified in Table 3-12 to be relevant to human health hazard from HBCD exposure. Therefore, occupational risk estimates are presented for only those endpoints representing the most sensitive and robust data within each health domain, with the presumption that evaluation of risks for these endpoints also account for all other less sensitive yet relevant endpoints. These PODs are presented in Table 4-12. For complete occupational MOE tables displaying risk estimates for all endpoints, see [*Risk Evaluation for Cyclic Aliphatic Bromide Cluster (HBCD), Supplemental File: Occupational Risk Calculator.* ([U.S. EPA 2019s](#))].

Table 4-12. Most Sensitive Endpoints From Each Health Domain Used for Risk Estimation

Toxicity Endpoint		POD _{HED} (mg/kg-d)	Benchmark MOE
Effects applicable to acute exposure scenarios			
Thyroid	Decreased maternal T4 (Ema et al. 2008)	22.5	30
Developmental	F2 generation offspring loss (Ema et al. 2008)	9.03	100
Effects following chronic exposure scenarios			
Thyroid	Decreased T4 (Ema et al. 2008)	1.68	300
Liver	Increased relative liver weight and vacuolization (WIL Research 2001)	24	1000
Female Reproductive	Reduced primordial follicles (Ema et al. 2008)	0.689	30
Developmental	F2 generation offspring loss (Ema et al. 2008)	9.03	100

Risk estimates are shown for the representative POD of each health domain following acute or chronic exposure, as shown below. As described above in Section 3.2.5.2.1, developmental toxicity outcomes may result from a single acute exposure during a critical window of development. Given this, the most relevant lifestage in the human population would be women of child-bearing age. However, due to uncertainty in the mode of action for HBCD developmental toxicity (*e.g.*, outcomes could be exclusively due to effects on the exposed unborn fetus in utero or they could also result from permanent damage to eggs) and the possibility of a bioaccumulative effect following a future acute exposure, risks for developmental toxicity were characterized for all lifestages.

4.2.2 Risk Estimation for Workers

The tables and narratives below describe the conclusions of the risk estimation via inhalation or dermal exposure for each use scenario following acute or chronic exposures. Risks were calculated for average adult workers as well as for women of reproductive age. Results presented below are for average adult workers. MOEs are approximately 10% lower for women of reproductive age compared to average adult workers, and differences in risk conclusions are identified in the tables and risk characterization narratives when applicable. For a complete list of all risk calculations, see [*Risk Evaluation for Cyclic Aliphatic Bromide Cluster (HBCD), Supplemental File: Occupational Risk Calculator* ([U.S. EPA 2019s](#))]. The risk estimates in the tables below and in the supplemental file are presented only for OES associated with ongoing manufacturing or import. Risk estimation for recycling of electronics waste containing HIPS is provided in Section 4.2.2.5.

EPA notes that OSHA requires employers apply the hierarchy of controls as discussed in Section 2.4.1.1 which first prioritizes elimination, substitution, engineering and administrative controls, and then if not feasible to address the hazard, the implementation of a respiratory protection program. Adjusted MOEs were not calculated based on glove protection because EPA does not expect any level of dermal exposure to HBCD following proper use of gloves impervious to HBCD. As discussed in Section 2.4.1.1, impervious gloves, if worn on clean hands and replaced when contaminated or compromised, are expected to provide employees with protection from HBCD. HBCD is a solid particulate and would not be expected to permeate through gloves (unlike certain solvents). Some examples of impervious

gloves are nitrile, butyl rubber, polyvinyl chloride, and polychloroprene. EPA did not identify any sufficient data or applicable model that can be used to adequately estimate inhalation exposure to particulates for ONUs. EPA assumes that exposures to ONUs would be lower than those for workers (Section 2.4.1.1).

PPE usage up to APF = 50 and including impervious gloves is assumed for all OES except installation and demolition (& disposal) of XPS/EPS foam insulation, for which respirator use is not assumed. Table 4-13 presents this information below. Risk estimates are presented displaying the APFs expected to mitigate risk for the exposure scenario (*e.g.*, acute inhalation) in the sections below.

Table 4-13. Inhalation Exposure Data Summary and Respirator Use Determination

Occupational Exposure Scenario	Inhalation Exposure Approach	Number of Data Points	Model Used	Approach for ONUs	Respirator Use	Industrial or Commercial OES
Repackaging of Import Containers	Monitoring data	10 (8-hr TWA)	N/A – monitoring data only	Exposures to ONUs are assumed to be less than those for workers. Risk estimates for inhalation exposure to ONUs were not quantified	May use respirators	Industrial
Compounding of Polystyrene Resin to Produce XPS Masterbatch	Monitoring data	16 (8-hr TWA)	N/A – monitoring data only	Exposures to ONUs are assumed to be less than those for workers. Risk estimates for inhalation exposure to ONUs were not quantified	May use respirators	Industrial
Processing of HBCD to Produce XPS Foam using XPS Masterbatch	Monitoring data	9 (8-hr TWA)	N/A – monitoring data only	Exposures to ONUs are assumed to be less than those for workers. Risk estimates for inhalation exposure to ONUs were not quantified	May use respirators	Industrial
Processing of HBCD to Produce XPS Foam using HBCD Powder	Monitoring data	16 (8-hr TWA)	N/A – monitoring data only	Exposures to ONUs are assumed to be less than those for workers. Risk estimates for inhalation exposure to ONUs were not quantified	May use respirators	Industrial
Processing of HBCD to Produce EPS Foam Using Imported EPS Resin Beads	Monitoring data	9 (8-hr TWA)	N/A – monitoring data only	Exposures to ONUs are assumed to be less than those for workers. Risk estimates for inhalation exposure to ONUs were not quantified	May use respirators	Industrial
Processing of HBCD to Produce SIPs and Automobile Replacement Parts from XPS/EPS Foam	Monitoring data	9 (8-hr TWA)	N/A – monitoring data only	Exposures to ONUs are assumed to be less than those for workers. Risk estimates for inhalation exposure to ONUs were not quantified	May use respirators	Industrial

Occupational Exposure Scenario	Inhalation Exposure Approach	Number of Data Points	Model Used	Approach for ONUs	Respirator Use	Industrial or Commercial OES
Installation of Automobile Replacement Parts	N/A – inhalation exposure not assessed	N/A – inhalation exposure not assessed	N/A – inhalation exposure not assessed	N/A – inhalation exposure not assessed	N/A – inhalation exposure not assessed	Commercial
Installation of XPS/EPS Foam Insulation in Residential, Public and Commercial Buildings, and Other Structures	Monitoring data	9 (8-hr TWA)	N/A – monitoring data only	Exposures to ONUs are assumed to be less than those for workers. Risk estimates for inhalation exposure to ONUs were not quantified	Not expected to use respirators	Commercial
Demolition and Disposal of XPS/EPS Foam Insulation Products in Residential, Public and Commercial Buildings, and Other Structures	N/A – modeling only	N/A – modeling only	OSHA PNOR PEL	Exposures to ONUs are assumed to be less than those for workers. Risk estimates for inhalation exposure to ONUs were not quantified	Not expected to use respirators	Commercial
Recycling of EPS Foam and Reuse of XPS foam	Monitoring data	9 (8-hr TWA)	N/A – monitoring data only	Exposures to ONUs are assumed to be less than those for workers. Risk estimates for inhalation exposure to ONUs were not quantified	May use respirators	Industrial/ Commercial
Formulation of Flux/Solder Pastes	Monitoring data	16 (8-hr TWA)	N/A – monitoring data only	Exposures to ONUs are assumed to be less than those for workers. Risk estimates for inhalation exposure to ONUs were not quantified	May use respirators	Industrial
Use of Flux/Solder Pastes	N/A – inhalation exposure not assessed	N/A – inhalation exposure not assessed	N/A – inhalation exposure not assessed	N/A – inhalation exposure not assessed	N/A – inhalation exposure not assessed	Industrial/ Commercial

EPA did not quantitatively assess occupational exposure associated with *Land Disposal of Formulated Products and Articles*. As described in Section 2.4.5.3, EPA assumes a low concentration in municipal waste disposed of at a landfill, and workers are not expected to be exposed to products or articles containing HBCD on a regular basis. Therefore, acute and chronic risks to workers from this COU are not expected in most circumstances. In worst-case scenarios where municipal waste is shredded, exposures may be elevated and there may be a greater possibility of acute risks on days where HBCD-containing products or articles are present. Therefore risks cannot be ruled out despite being of lower likelihood. This uncertainty is further described in Section 4.3.2.3.

4.2.2.1 Occupational Risk Estimation for Non-Cancer Effects Following Acute Inhalation Exposures

Risks to workers were estimated for non-cancer effects following acute inhalation exposures. Table 4-14 displays MOE values for all occupational scenarios and human health hazards associated with acute exposure, including results assuming either respiratory protection of APF = 5 or APF = 10. Risks were not identified for any scenario assuming respiratory protection of APF = 5 or greater. Inhalation risks were not estimated for the following exposure scenarios because worker inhalation exposures are not expected: *Installation of Automobile Replacement Parts* and *Use of Flux/Solder Paste*.

Table 4-14. Risk Estimation for Non-Cancer Effects Following Acute Inhalation Exposures

Occupational Exposure Scenario – Inhalation Exposure	[Benchmark MOE = 100]						[Benchmark MOE = 30]					
	POD _{HED} (mg/kg) = 9.03 Developmental Toxicity F2 offspring loss (Ema et al. 2008)						POD _{HED} (mg/kg) = 22.5 Thyroid Hormone Changes Decreased maternal T4 (Ema et al. 2008)					
	High-End Exposure			Central Tendency Exposure			High-End Exposure			Central Tendency Exposure		
	No Protection	APF = 5	APF = 10	No Protection	APF = 5	APF = 10	No Protection	APF = 5	APF = 10	No Protection	APF = 5	APF = 10
Repackaging of Import Containers	38	191	382	81	406	812	95	476	952	202	1011	2022
Compounding of Polystyrene Resin to Produce XPS Masterbatch	29	144	289	58	289	578	72	360	720	144	720	1440
Processing of HBCD to produce XPS Foam Using XPS Masterbatch	328	1642	3284	903	4515	9030	818	4091	8182	2250	11250	22500
Processing of HBCD to produce XPS Foam Using HBCD Powder	29	144	289	58	289	578	72	360	720	144	720	1440
Processing of HBCD to produce EPS Foam Using Imported EPS Resin Beads	328	1642	3284	903	4515	9030	818	4091	8182	2250	11250	22500
Processing of HBCD to produce SIPs and Automobile Replacement Parts from XPS/EPS Foam	328	1642	3284	903	4515	9030	818	4091	8182	2250	11250	22500
Installation of Automobile Replacement Parts	--	--	--	--	--	--	--	--	--	--	--	--
Installation of XPS/EPS Foam Insulation in Residential, Public and Commercial Buildings, and Other Structures	328	1642 ^a	3284 ^a	903	4515 ^a	9030 ^a	818	4091 ^a	8182 ^a	2250	11250 ^a	22500 ^a
Demolition and disposal of XPS/EPS Foam Insulation Products in Residential, Public and Commercial Buildings, and Other Structures	241	1204 ^a	2408 ^a	688	3440 ^a	6880 ^a	600	3000 ^a	6000 ^a	1714	8571 ^a	17143 ^a
Recycling of EPS Foam	328	1642	3284	903	4515	9030	818	4091	8182	2250	11250	22500
Formulation of Flux / Solder Paste	29	144	289	58	289	578	72	360	720	144	720	1440
Use of Flux / Solder Paste	--	--	--	--	--	--	--	--	--	--	--	--

- As discussed in Section 2.4.1.1 EPA expects potential inhalation exposure of an Occupational Non-User (ONU) in the case of some of the conditions of use but EPA did not quantitatively assess these exposures due to lack of adequate data. EPA assumes that these exposures would be lower than the exposures of the corresponding workers.

- **Bold**/shaded text indicates MOE is less than the benchmark MOE. Non-bold text indicates the MOE is greater than the benchmark MOE. -- indicates that exposures are not expected during this exposure scenario.

^a EPA is presenting MOEs for respiratory PPE up to APF = 10 as a what-if scenario, however EPA believes that workers in these OES are unlikely to wear respirators.

4.2.2.2 Occupational Risk Estimation for Non-Cancer Effects Following Chronic Inhalation Exposures

Risks to workers were calculated for non-cancer effects following chronic inhalation exposures. Table 4-15 displays MOE values for all occupational scenarios and human health hazards associated with chronic exposure, including results assuming either respiratory protection of APF =10 and APF = 50. Risks were not identified for any scenario assuming respiratory protection of APF = 50 or greater. Inhalation risks were not estimated for the following exposure scenarios because worker inhalation exposures are not expected: *Installation of Automobile Replacement Parts* and *Use of Flux/Solder Paste*.

Table 4-15. Risk Estimation for Non-Cancer Effects Following Chronic Inhalation Exposures

Occupational Exposure Scenario – Inhalation Exposure	MARGIN OF EXPOSURE (MOE)											
	Benchmark MOE = 300			Benchmark MOE = 1000			Benchmark MOE = 30			Benchmark MOE = 100		
	POD _{HED} (mg/kg) = 1.68 Thyroid Effects Decreased T4 (Ema et al. 2008)			POD _{HED} (mg/kg) = 24 Liver Toxicity Increased relative liver weight and vacuolization (WIL Research 2001)			POD _{HED} (mg/kg) = 0.689 Female Reproductive Toxicity Reduced primordial follicles (Ema et al. 2008)			POD _{HED} (mg/kg) = 9.03 Developmental Toxicity F2 offspring loss (Ema et al. 2008)		
	None	APF = 10	APF = 50	None	APF = 10	APF = 50	None	APF = 10	APF = 50	None	APF = 10	APF = 50
Repackaging of import containers (HE)	10	104	519	148	1483	7416	4	43	213	56	558	2790
Repackaging of import containers (CT)	39	394	1969	562	5624	28122	16	161	807	212	2116	10581
Compounding of Polystyrene Resin to Produce XPS Masterbatch (HE)	33	327*	1635	467	4672	23360	13	134	671	176	1758	8789
Compounding of Polystyrene Resin to Produce XPS Masterbatch (CT)	112	1121	5606	1602	16018	80091	46	460	2299	603	6027	30134
Processing of HBCD to produce XPS Foam Using XPS Masterbatch (HE)	1394	13936	69682	19909	199091	995455	572	5716	28578	7491	74908	374540
Processing of HBCD to produce XPS Foam Using XPS Masterbatch (CT)	6813	68133	340667	97333	973333	4866667	2794	27943	139714	36622	366217	1831083
Processing of HBCD to produce XPS Foam Using HBCD Powder (HE)	123	1226	6132	1752	17520	87600	50	503	2515	659	6592	32960
Processing of HBCD to produce XPS Foam Using HBCD Powder (CT)	436	4361	21803	6229	62293	311467	179	1788	8942	2344	23438	117189
Processing of HBCD to produce EPS Foam Using Imported EPS Resin Beads (HE)	159	1593	7964	2275	22753	113766	65	653	3266	856	8561	42805
Processing of HBCD to produce EPS Foam Using Imported EPS Resin Beads (CT)	786	7862	39308	11231	112308	561538	322	3224	16121	4226	42256	211279
Processing of HBCD to produce SIPs and Automobile Replacement Parts from XPS/EPS Foam (HE)	89	892	4460	1274	12742	63709	37	366	1829	856	8561	42805

Occupational Exposure Scenario – Inhalation Exposure	MARGIN OF EXPOSURE (MOE)											
	Benchmark MOE = 300			Benchmark MOE = 1000			Benchmark MOE = 30			Benchmark MOE = 100		
	POD _{HED} (mg/kg) = 1.68 Thyroid Effects Decreased T4 (Ema et al. 2008)			POD _{HED} (mg/kg) = 24 Liver Toxicity Increased relative liver weight and vacuolization (WIL Research 2001)			POD _{HED} (mg/kg) = 0.689 Female Reproductive Toxicity Reduced primordial follicles (Ema et al. 2008)			POD _{HED} (mg/kg) = 9.03 Developmental Toxicity F2 offspring loss (Ema et al. 2008)		
	None	APF = 10	APF = 50	None	APF = 10	APF = 50	None	APF = 10	APF = 50	None	APF = 10	APF = 50
Processing of HBCD to produce SIPs and Automobile Replacement Parts from XPS/EPS Foam (CT)	461	4611	23053	6586	65865	329323	189	1891	9454	4226	42256	211279
Installation of Automobile Replacement Parts (HE)	--	--	--	--	--	--	--	--	--	--	--	--
Installation of Automobile Replacement Parts (CT)	--	--	--	--	--	--	--	--	--	--	--	--
Installation of XPS/EPS Foam Insulation in Residential, Public and Commercial Buildings, and Other Structures (HE)	89	892 ^a	4460 ^a	1274	12742 ^a	63709 ^a	37	366 ^a	1829 ^a	479	4794 ^a	23971 ^a
Installation of XPS/EPS Foam Insulation in Residential, Public and Commercial Buildings, and Other Structures (CT)	487	4867 ^a	24333 ^a	6952	69524 ^a	347619 ^a	200	1996 ^a	9980 ^a	2616	26158 ^a	130792 ^a
Demolition and Disposal of XPS/EPS Foam Insulation Products in Residential, Public and Commercial Buildings, and Other Structures (HE)	65	654 ^a	3270 ^a	934	9344 ^a	46720 ^a	27	268 ^a	1341 ^a	352	3516 ^a	17578 ^a
Demolition and Disposal of XPS/EPS Foam Insulation Products in Residential, Public and Commercial Buildings, and Other Structures (CT)	371	3708 ^a	18540 ^a	5297	52971 ^a	264853 ^a	152	1521 ^a	7603 ^a	1993	19930 ^a	99651 ^a
Recycling of EPS Foam (HE)	159	1593	7964	2275	22753	113766	65	653	3266	856	8561	42805
Recycling of EPS Foam (CT)	864	8637	43183	12338	123380	616901	354	3542	17710	4642	46422	232109
Formulation of Flux / Solder Paste (HE)	8	78	392	112	1121	5606	3	32	161	42	422	2109

Occupational Exposure Scenario – Inhalation Exposure	MARGIN OF EXPOSURE (MOE)											
	Benchmark MOE = 300			Benchmark MOE = 1000			Benchmark MOE = 30			Benchmark MOE = 100		
	POD _{HED} (mg/kg) = 1.68 Thyroid Effects Decreased T4 (Ema et al. 2008)			POD _{HED} (mg/kg) = 24 Liver Toxicity Increased relative liver weight and vacuolization (WIL Research 2001)			POD _{HED} (mg/kg) = 0.689 Female Reproductive Toxicity Reduced primordial follicles (Ema et al. 2008)			POD _{HED} (mg/kg) = 9.03 Developmental Toxicity F2 offspring loss (Ema et al. 2008)		
	None	APF = 10	APF = 50	None	APF = 10	APF = 50	None	APF = 10	APF = 50	None	APF = 10	APF = 50
Formulation of Flux / Solder Paste (CT)	31	307*	1533	438	4380	21900	13	126	629	165	1648	8240
Use of Flux / Solder Paste (HE)	--	--	--	--	--	--	--	--	--	--	--	--
Use of Flux / Solder Paste (CT)	--	--	--	--	--	--	--	--	--	--	--	--
<p>- As discussed in Section 2.4.1.1 EPA expects potential inhalation exposure of an Occupational Non-User (ONU) in the case of some of the conditions of use but EPA did not assess these exposures due to lack of adequate reasonably available data. EPA assumes that these exposures would be lower than the exposures of the corresponding workers.</p> <p>- Bold/shaded text indicates MOE is less than the benchmark MOE. Non-bold/non-shaded text indicates the MOE is greater than the benchmark MOE. HE = High-End exposure level; CT = Central Tendency exposure level; -- indicates that exposures are not expected during this exposure scenario.</p> <p>“None” refers to respiratory protection.</p> <p>- * indicates that risks are identified for women of reproductive age only. See text below for details.</p> <p>^a EPA is presenting MOEs for respiratory PPE up to APF = 50 as a what-if scenario, however EPA believes that workers in these OES are unlikely to wear respirators.</p>												

4.2.2.3 Occupational Risk Estimation for Non-Cancer Effects Following Acute Dermal Exposures

Risks to workers were calculated for non-cancer effects following acute dermal exposures, assuming 6.5% systemic absorption (see Section 3.2.2). Table 4-16 displays MOE values for all occupational scenarios and human health hazards associated with acute dermal exposure. As mentioned above, adjusted MOEs were not calculated based on glove protection because EPA does not expect any level of dermal exposure to HBCD following proper use of impervious gloves.

Table 4-16. Risk Estimation for Non-Cancer Effects Following Acute Dermal Exposures

Occupational Exposure Scenario – Dermal Exposure	[Benchmark MOE = 100]		[Benchmark MOE = 30]	
	POD _{HED} (mg/kg) = 9.03 Developmental Toxicity F2 offspring loss (Ema et al. 2008)		POD _{HED} (mg/kg) = 22.5 Thyroid Hormone Changes Decreased maternal T4 (Ema et al. 2008)	
	High-End	Central Tendency	High-End	Central Tendency
Repackaging of Import Containers	4	12	9	31
Compounding of Polystyrene Resin to Produce XPS Masterbatch	4	12	9	31
Processing of HBCD to produce XPS Foam Using XPS Masterbatch	5	18	13	44
Processing of HBCD to produce XPS Foam Using HBCD Powder	4	12	9	31
Processing of HBCD to produce EPS Foam Using Imported EPS Resin Beads	--	--	--	--
Processing of HBCD to produce SIPs and Automobile Replacement Parts from XPS/EPS Foam	--	--	--	--
Installation of Automobile Replacement Parts	--	--	--	--
Installation of XPS/EPS Foam Insulation in Residential, Public and Commercial Buildings, and Other Structures	--	--	--	--
Demolition of XPS/EPS Foam Insulation Products in Residential, Public and Commercial Buildings, and Other Structures	--	--	--	--
Recycling of EPS Foam	--	--	--	--
Formulation of Flux / Solder Paste	4	12	9	31
Use of Flux / Solder Paste	1010	2470	2517	6154

- As discussed in Section 2.4.1, there was no data to assess Occupational Non-User (ONU) exposures.
- **Bold/shaded** text indicates MOE is less than the benchmark MOE. Non-bold/non-shaded text indicates the MOE is greater than the benchmark MOE. -- Indicates that exposures are not expected during this exposure scenario.

4.2.2.4 Occupational Risk Estimation for Non-Cancer Effects Following Chronic Dermal Exposures

Risks to workers were calculated for non-cancer effects following chronic dermal exposures, assuming 6.5% systemic absorption (see Section 3.2.2). Table 4-17 displays MOE values for all occupational scenarios and human health hazards associated with chronic dermal exposure. As mentioned above, adjusted MOEs were not calculated based on glove protection because EPA does not expect any level of dermal exposure to HBCD following proper use of impervious gloves.

Table 4-17. Risk Estimate for Workers – Non-Cancer Effects Following Chronic Dermal Exposures

Occupational Scenario – Dermal Exposure	MARGIN OF EXPOSURE (MOE)							
	Benchmark MOE = 300		Benchmark MOE = 1000		Benchmark MOE = 30		Benchmark MOE = 100	
	POD _{HED} (mg/kg) = 1.68		POD _{HED} (mg/kg) = 24		POD _{HED} (mg/kg) = 0.689		POD _{HED} (mg/kg) = 9.03	
	Thyroid Effects Decreased T4 (Ema et al. 2008)		Liver Toxicity Increased relative liver weight and vacuolization (WIL Research 2001)		Female Reproductive Toxicity Reduced primordial follicles (Ema et al. 2008)		Developmental Toxicity F2 offspring loss (Ema et al. 2008)	
Repackaging of Import Containers	1 (1.0)	2 (1.7)	14	25	0 (0.4)	(0.7)	5	9
Compounding of Polystyrene Resin to Produce XPS Masterbatch	4	7	58	99	2	3	22	37
Processing of HBCD to produce XPS Foam Using XPS Masterbatch	22	39	311	552	9	16	117	208
Processing of HBCD to produce XPS Foam Using HBCD Powder	15	27	217	386	6	11	82	145
Processing of HBCD to produce EPS Foam Using Imported EPS Resin Beads	--	--	--	--	--	--	--	--
Processing of HBCD to produce SIPs and Automobile Replacement Parts from XPS/EPS Foam	--	--	--	--	--	--	--	--
Installation of Automobile Replacement Parts	--	--	--	--	--	--	--	--
Installation of XPS/EPS Foam Insulation in Residential, Public and Commercial Buildings, and Other Structures	--	--	--	--	--	--	--	--
Demolition and Disposal of XPS/EPS Foam Insulation Products in Residential, Public and Commercial Buildings, and Other Structures	--	--	--	--	--	--	--	--
Recycling of EPS Foam	--	--	--	--	--	--	--	--
Formulation of Flux / Solder Paste	1 (1.0)	2 (1.9)	14	27	0 (0.4)	1 (0.8)	5	10
Use of Flux / Solder Paste	274	540	3921	7718	113	222	1475	2904

- As discussed in Section 2.4.1, there was no adequate data available to quantitatively assess Occupational Non-User (ONU) exposures.

- **Bold/shaded** text indicates MOE is less than the benchmark MOE. Non-bold/non-shaded text indicates the MOE is greater than the benchmark MOE.

- -- indicates that exposures are not expected during this exposure scenario.

- * indicates that risks are identified for women of reproductive age only. See text below for details.

4.2.2.5 Occupational Risk Estimation for the Recycling of Electronics Waste Containing HIPS

HBCD from the recycling of electronics waste containing HIPS has been identified as an ongoing exposure scenario and COU. Although HBCD is no longer used in electronics manufacturing, recycling of old electronics waste containing HIPS with HBCD may result in acute and chronic exposures to workers and ONUs. Occupational exposures for this OES are detailed in Section 2.4.1.14. As shown in Table 4-18, risk estimates for this OES are well above the benchmark MOE and therefore risks are not identified for either acute or chronic exposures from electronics waste recycling.

Table 4-18. Risk Estimates for Recycling of Electronics Waste Containing HIPS

Acute Exposures		Chronic Exposures	
POD_{HED} (mg/kg) = 9.03; Benchmark MOE = 100 Developmental Toxicity F2 offspring loss (Ema et al. 2008)		POD_{HED} (mg/kg) = 1.68; Benchmark MOE = 300 Thyroid Effects Decreased T4 (Ema et al. 2008)	
High-End	Central Tendency	High-End	Central Tendency
722400	5197122	196224	2778904

4.2.3 Risk Estimation for General Population and Consumers

4.2.3.1 General Population Risk Estimation for Non-Cancer Effects – Background Exposure

Risks were estimated for the general population, representing chronic, steady-state risks from sustained background exposure in the environment due to HBCD persistence. In this assessment, general population is considered to be individuals who are not expected to live close to point sources and are not expected to have HBCD articles in their home. HBCD exposures to the general population are highly variable and are influenced by both sources into the environment and degradation and removal from the environment. Estimates of general population exposures based on environmental monitoring and biomonitoring data represent the conditions present at the time the data was collected. It is unknown which combination of potential sources associated with conditions of use as described in this risk assessment contribute to the monitoring data presented here. However, given the wide range of exposures shown within and across the monitoring data, there is a plausible contribution from some of the sources/conditions of use described within this document. The totality of background exposure includes steady-state environmental exposures ongoing releases not associated with a particular COU, background/indirect exposures from minor use products (*e.g.*, textiles, electrical and electronic products, adhesives, and coatings) (Section 1.2.8), and releases stemming from historical activities (Section 1.2.9) due to HBCD's persistence in the environment. To be health protective, general population risks for background exposure were estimated based on the total aggregate exposure.

General population risk estimates account for steady-state background exposure in the environment independent of any specific release. Therefore, only risks for chronic exposures are applicable. The MOE tables below represent risks to aggregate steady-state HBCD exposure, combining dust, soil, indoor air, diet, and dermal pathways. See Section 2.4.2 for a more detailed explanation of these exposure pathways. Table 4-19 presents the MOEs for general population risks at both central tendency (50th percentile) and high-end (95th percentile) exposure levels. General population risks from background exposure are presented for the most sensitive and robust endpoints within each health domain, as described in Section 4.2.1.1 and presented in Table 4-12.

Table 4-19. General Population Risk Estimation for Non-Cancer Effects – Background Exposure

Aggregate Background Exposure	Benchmark MOE = 300 POD _{HED} (mg/kg) = 1.68		Benchmark MOE = 1000 POD _{HED} (mg/kg) = 24		Benchmark MOE = 30 POD _{HED} (mg/kg) = 0.689		Benchmark MOE = 100 POD _{HED} (mg/kg) = 9.03	
	Thyroid Effects Decreased T4 (Ema et al. 2008)		Liver Toxicity Increased relative liver weight and vacuolization (WIL Research 2001)		Female Reproductive Toxicity Reduced primordial follicles (Ema et al. 2008)		Developmental Toxicity F2 offspring loss (Ema et al. 2008)	
AGE GROUP	CT	HE	CT	HE	CT	HE	CT	HE
<1 year	42129	9959	601845	142270	17278	4084	226444	53529
1-<2 years	57455	15008	820789	214397	23563	6155	308822	80667
2-<3 years	92421	18315	1320304	261643	37904	7511	496764	98443
3-<6 years	124794	24118	1782765	344547	51180	9891	670765	129636
6-<11 years	196938	37886	2813399	541231	80768	15538	1058542	203638
11-<16 years	387473	74008	5535329	1057256	158910	30352	2082667	397793
16-<70 years	545441	98963	7792016	1413762	223696	40587	2931746	531928

MOEs were greater than an order of magnitude of the benchmark MOE for any health endpoint even at the most sensitive lifestage and therefore HBCD is not expected to present risk to the general population due to background exposure (not associated with any specific point source of HBCD release) based on environmental and biomonitoring exposure data.

4.2.3.1.1 Occupational Microenvironments

Exposures from occupational microenvironments involving residual, background exposures in occupational settings were also estimated as a subset of aggregate general population exposures (Section 2.4.2.2.6). These may include exposures due to formulated products and articles (*e.g.*, textiles, electrical and electronic products, adhesives, and coatings). These exposures represent background values and therefore are only applicable to risk from chronic exposures, similar to background general population exposure (Section 4.2.3.1). Based on the chronic POD of thyroid effects, using the high-end exposure estimate from total occupational microenvironments of 5.25E-06 mg/kg-day (Table 2-91), the MOE = 320,000, well above the benchmark of 100. Therefore, risks are not identified for chronic exposures from occupational microenvironments.

Exposures from formulated products and articles (*e.g.*, textiles, electrical and electronic products, adhesives, and coatings) comprise a non-quantifiable subset of the total occupational microenvironment exposure since these aggregate exposures likely include other sources as well, including releases stemming from historical activities (Section 1.2.9) due to HBCD's persistence. Therefore, risk estimates for these minor use products are by extension greater than 320,000 and risks are not identified for that COU.

4.2.3.2 General Population Risk Estimation for Non-Cancer Effects – Subsistence Fishers

Risks were also estimated for subsistence fishers based on aggregate exposure. Subsistence fishers represent a PESS group for HBCD due to their greatly increased exposure via fish ingestion (142.4 g/day compared to a high-end of 22.2 g/day for the general population). Based on the increased ingestion rate ([U.S. EPA 2000a](#)) and various measured HBCD concentrations in fish both downstream (Near Field) and far away (Far Field) from a releasing facility, EPA estimated risks in a similar manner as the general population (Section 4.2.3.1). See Section 2.4.2.5 for complete details on the exposure assessment for subsistence fishers.

Table 4-20. General Population Risk Estimation for Non-Cancer Effects – Subsistence Fishers

Aggregate Exposure - Subsistence Fishers	Benchmark MOE = 300 POD _{HED} (mg/kg) = 1.68		Benchmark MOE = 1000 POD _{HED} (mg/kg) = 24		Benchmark MOE = 30 POD _{HED} (mg/kg) = 0.689		Benchmark MOE = 100 POD _{HED} (mg/kg) = 9.03	
	Thyroid Effects Decreased T4 (Ema et al. 2008)		Liver Toxicity Increased relative liver weight and vacuolization (WIL Research 2001)		Female Reproductive Toxicity Reduced primordial follicles (Ema et al. 2008)		Developmental Toxicity F2 offspring loss (Ema et al. 2008)	
GROUP	CT	HE	CT	HE	CT	HE	CT	HE
Near Field	2252	2215	32168	31642	923	908	12103	11905
Far Field 1	38631	30060	551868	429435	15843	12328	207640	161575
Far Field 2	125980	65283	1799717	932610	51667	26774	677144	350895

MOEs were several fold above the benchmark MOE for any health endpoint and therefore HBCD is not expected to present risk to subsistence fishers living either nearby or distant from an HBCD point source.

4.2.3.3 General Population Risk Estimation for Non-Cancer Effects – Highly Exposed Populations

Risks were calculated for the highly exposed general population, a subset of Potentially Exposed or Susceptible Subpopulations (PESS) living near a point source of HBCD release (*e.g.*, for inhalation, within 100 meters for high-end and within 1000 meters for central tendency). For simplicity, the tables below present risks considering acute or chronic exposure via fish ingestion, inhalation, and additional exposure pathways using the most sensitive POD for either acute or chronic exposure scenarios. MOEs for all other hazards would be higher than the presented values. Exposure via fish ingestion is the primary driver for any risks identified to the highly exposed general population, except for infants whom are not anticipated to ingest fish in their diet. Infants would be uniquely exposed through breast milk, with the received dose dependent on the body burden of the mother.

As discussed in Section 3.2.5.2.1, both reduced pup body weight and offspring loss were considered as relevant hazard for evaluating risks following acute exposure. There is substantial uncertainty whether a single exposure can produce a permanent adverse effect on postnatal mortality or body weight. EPA determined that the sustained persistence of HBCD in human tissue suggests that a single exposure could have sustained effects. EPA evaluated risks for offspring loss for all lifestages, including those below reproductive age. While developmental effects would not be expected to present in younger lifestages below reproductive age (*i.e.*, they would be expected to affect the offspring of an exposed individual), the bioaccumulation and persistence of HBCD in tissues suggests that initial exposure at an earlier age could result in effects later in life. Additionally, it is unknown whether developmental effects observed in gestationally exposed neonates could also present in older exposed children. Therefore, despite the uncertainties, developmental outcomes were considered potentially applicable to acute exposures at all lifestages, however developmental toxicity to teenagers and adults would be of highest concern. Based on this health-protective approach, risk estimates are only provided for the most sensitive endpoint of acute (offspring loss) and chronic (decreased T4 levels) exposure scenarios.

The MOE tables for fish ingestion and inhalation incorporate summed exposures from representative fish ingestion or air inhalation modeled exposures and aggregate central tendency general population biomonitoring-based exposures (representing background exposure). Background exposure estimates were adjusted from the overall general population exposure values to remove the route of interest (*e.g.*, fish ingestion or air inhalation) in order to avoid double-counting because exposure via a particular route is likely geographically specific and risk estimates are only based on OES-specific exposures. Therefore, exposures were only aggregated from different routes but not within routes. EPA evaluated exposures for each exposure scenario assuming several differing release scenarios (see Table 2-54 and Table 2-55). MOE tables in Section 4.2.3.3 present risks for two exposure sub-scenarios under each exposure scenario, including both the scenario resulting in the highest exposure and a representative moderate exposure level based on variability in estimated releases and wastewater treatment. The risk estimates in the tables below are presented only for OES associated with ongoing manufacturing or import. Risks were also estimated for *Recycling of Electronics Waste Containing HIPS* based on relative comparison of release estimates and associated MOEs. These results are as presented in Section 4.2.3.3.1.

EPA is unable to model estimations of breast milk ingestion for <1 year old infants associated with an exposure scenario, so exposures are based on monitoring data. Dietary risk estimation for highly exposed infants was therefore based on high-end general population exposure values (applicable to chronic exposures only). EPA additionally estimated risk for two scenarios from exposure to HBCD via consumer articles. MOE tables for these scenarios incorporated the sum of cumulative dust and air exposure and background general population exposure (with general population dust and air values

removed). Risk estimates are also provided for chronic exposure to HBCD via mouthing of plastic articles containing HBCD.

EPA assessed risks to the highly exposed population following acute or chronic exposures independently, however these do not necessarily represent independent populations. An individual living near a facility would have both acute and chronic exposures to HBCD over time. Only short-term residents or visitors would experience acute but not chronic exposures.

4.2.3.3.1 General Population Risk Estimation for Non-Cancer Effects Following Acute Exposures – Highly Exposed Populations

Risks to the highly exposed population were calculated for non-cancer effects following acute exposures based on fish ingestion and inhalation.

Risks via Fish Ingestion / Dietary Exposure

Risks were not estimated for the following exposure scenarios via dietary exposure because releases were not identified, or associated exposures were not quantified:

- OES #7, *Installation of Automobile Replacement Parts*
- OES #11, *Formulation of Flux / Solder Paste*

A description of all subscenarios for OES resulting in fish ingestion exposure can be found in Table 2-54.

Highly Exposed Population

Infants

Infants <1 year old are not expected to ingest fish in their diet ([U.S. EPA 2011b](#)) (as discussed in Section 2.4.2). Therefore, dietary risks to highly exposed infants were estimated based on high-end general population exposure values, which incorporates breast milk in its dietary component as well as high-end estimates of dust, dermal, air, and soil exposure. Infant risks are based on steady-state exposures estimated via biomonitoring and are not associated with a particular exposure scenario. Similar to the risk estimation for general population, the risk estimation for highly exposed infants is therefore only relevant to chronic exposures. Therefore, risks were not estimated for highly exposed infants following acute exposures.

Other lifestages

EPA estimated risks to the highly exposed general population following acute exposure via fish ingestion. EPA selected high-end fish ingestion rates and 10th percentile stream flow rates for calculation of ADR values in order to represent high-end acute exposures. ADR does not represent single-day releases from a facility but instead high-end (as it is unlikely to be sustained every day) values for ingestion of exposed fish. Fish concentrations were estimated based on 21-day average dissolved HBCD in the water column and estimated BAF values. See Section 2.4.3.2 for a full description of the fish ingestion exposure assessment.

Table 4-21 displays risk estimates for each condition of use and life stage following acute HBCD exposure (as the sum of acute fish ingestion dose (ADR) and central tendency non-fish pathway dose) based on the most sensitive relevant hazard endpoint of offspring loss. Scenario-specific discussions of risk are below.

Table 4-21. Risk Estimation for Non-Cancer Effects Following Acute Exposure to Highly Exposed Population - Fish Ingestion

Developmental Toxicity - F2 Offspring Loss						
POD_{HED} (mg/kg) = 9.03; Benchmark MOE = 100						
SCENARIO NAME	Age Group / Lifestage					
	1- <2 years	2- <3 years	3- <6 years	6 - <11 years	11- <16 years	16- <70 years
1.5 Repackaging of Import Containers (Moderate Exposure)	1678	2034	2223	2865	4749	2508
1.7 Repackaging of Import Containers (Highest Exposure)	336	407	445	573	949	500
2.11 Compounding of Polystyrene Resin to Produce XPS Masterbatch (Moderate Exposure)	15033	18419	20261	26239	43649	23324
2.3 Compounding of Polystyrene Resin to Produce XPS Masterbatch (Highest Exposure)	1763	2138	2337	3011	4992	2636
3.4 Manufacturing of XPS Foam using XPS Masterbatch (Moderate Exposure)	7187	8751	9590	12383	20556	10907
3.3 Manufacturing of XPS Foam using XPS Masterbatch (Highest Exposure)	509	617	674	868	1439	759
4.2 Manufacturing of XPS Foam using HBCD Powder (Moderate Exposure)	14541	17810	19586	25360	42181	22530
4.1 Manufacturing of XPS Foam using HBCD Powder (Highest Exposure)	1308	1585	1732	2231	3699	1952
5.8 Manufacturing of EPS Foam using Imported EPS Resin beads (Moderate Exposure)	139	168	184	237	392	207
5.7 Manufacturing of EPS Foam using Imported EPS Resin beads (Highest Exposure)	14	17	18	24	39	21
6.4 Manufacturing of SIPs and Automobile Replacement Parts (Moderate Exposure)	4234	5143	5629	7260	12043	6373
6.7 Manufacturing of SIPs and Automobile Replacement Parts (Highest Exposure)	922	1117	1221	1573	2606	1375
8.1 Installation of Insulation in Buildings (Moderate Exposure)	16081	19721	21704	28119	46789	25026
8.3 Installation of Insulation in Buildings (Highest Exposure)	1687	2045	2235	2880	4775	2521
9.4 Demolition and Disposal of XPS/EPS Foam (Moderate Exposure)	2520	3057	3343	4309	7144	3775
9.3 Demolition and Disposal of XPS/EPS Foam (Highest Exposure)	254	307	336	432	717	378
10.3 Recycling of EPS Foam (Moderate Exposure)	7939	9672	10603	13695	22739	12073
10.7 Recycling of EPS Foam (Highest Exposure)	764	925	1011	1302	2158	1139
12.2 Use of Flux/Solder Paste (Moderate Exposure)	127338	171660	200726	273654	472637	290909
12.6 Use of Flux/Solder Paste (Highest Exposure)	80233	103797	118076	157180	266670	152982

- MOEs represent risk from aggregate exposure values from fish ingestion ADR and background general population (non-fish ingestion) exposure.
- Bold text indicates MOE is less than the benchmark MOE. Non-bold text indicates the MOE is greater than the benchmark MOE.

Estimated risks are above the benchmark MOE for the highly exposed general population for all exposure scenarios except for *Manufacturing of EPS Foam from Imported EPS Resin Beads*.

Manufacturing of EPS Foam from Imported EPS Resin Beads

The MOE is below the benchmark MOE for all lifestages from the highest exposure sub-scenario (5.7) but not under the representative moderate exposure scenario (5.8). MOEs for sub-scenario 5.7 ranged from 14 - 39, benchmark MOE = 100. Quantitative risk estimates are only provided for sub-scenarios 5.7 and 5.8 as representative exposure levels; however, EPA has determined that estimated risks are below the benchmark MOE for at least the most sensitive lifestage (young toddlers) under 4 of the 12 evaluated sub-scenarios.

Risks via Inhalation

Risks were not assessed for the following exposure scenarios via dietary exposure because releases were not identified or associated exposures were not quantified:

OES #7, *Installation of Automobile Replacement Parts*

A description of all subscenarios for OES resulting in outdoor air inhalation exposure can be found in Table 2-55. Table 4-22 displays risk estimates for each occupational scenario and life stage following acute HBCD exposure (as the sum of acute air inhalation dose (ADR) and central tendency non-air pathways dose) based on the most sensitive hazard endpoint of offspring loss. Estimation of the risk is above the benchmark MOE for the highly exposed population at all lifestages for all exposure scenarios (including the highest exposure sub-scenarios) following acute exposures. Acute inhalation risks are based on ADR exposures of average daily air concentrations at the fence line of a facility, 100 meters from the source. See Section 2.4.3.3 for a full description of the air inhalation exposure assessment.

Table 4-22. Risk Estimation for Non-Cancer Effects Following Acute Exposure to Highly Exposed Population - Inhalation

POD_{HED} (mg/kg) = 9.03							
Developmental Toxicity - F2 Offspring Loss; Benchmark MOE = 100							
SCENARIO NAME	Age Group / Lifestage						
	<1 years	1- <2 years	2- <3 years	3- <6 years	6 - <11 years	11- <16 years	16- <70 years
1.5 Repackaging of Import Containers (Moderate Exposure)	37630	40969	48241	64630	92743	129072	188277
1.3 Repackaging of Import Containers (Highest Exposure)	1307	1369	1551	2075	2950	3998	5844
2.5 Compounding of Polystyrene Resin to Produce XPS Masterbatch (Moderate Exposure)	209835	280262	434299	587718	914715	1691903	2405171
2.3 Compounding of Polystyrene Resin to Produce XPS Masterbatch (Highest Exposure)	128508	155035	206152	277322	410989	632620	915103
3.3 Manufacturing of XPS Foam using XPS Masterbatch (Moderate Exposure)	20056	21431	24750	33138	47331	64982	94891
3.1 Manufacturing of XPS Foam using XPS Masterbatch (Highest Exposure)	2743	2878	3264	4368	6212	8426	12316
4.7 Manufacturing of XPS Foam using HBCD Powder (Moderate Exposure)	39449	43033	50776	68031	97674	136136	198559
4.9 Manufacturing of XPS Foam using HBCD Powder (Highest Exposure)	2622	2751	3120	4175	5938	8053	11771
5.3 Manufacturing of EPS Foam using Imported EPS Resin beads (Moderate Exposure)	4705	4948	5623	7525	10707	14541	21252
5.7 Manufacturing of EPS Foam using Imported EPS Resin beads (Highest Exposure)	680	712	806	1078	1532	2075	3034
6.5 Manufacturing of SIPs and Automobile Replacement Parts (Moderate Exposure)	154878	192899	267999	361101	542143	872628	1257281
6.3 Manufacturing of SIPs and Automobile Replacement Parts (Highest Exposure)	14212	15094	17323	23189	33072	45215	66047
8.4 Installation of Insulation in Buildings (Moderate Exposure)	77282	87880	108591	145710	211652	305501	444324
8.2 Installation of Insulation in Buildings (Highest Exposure)	62609	70043	84954	113924	164690	234279	341143
9.1 Demolition and Disposal of XPS/EPS Foam (Moderate Exposure)	224448	305663	490103	664203	1046702	2044031	2889182
9.2 Demolition and Disposal of XPS/EPS Foam (Highest Exposure)	10310	10905	12465	16684	23771	32409	47352
10.7 Recycling of EPS Foam (Moderate Exposure)	140770	172342	233750	314673	469041	736216	1063132
10.3 Recycling of EPS Foam (Highest Exposure)	38255	41677	49110	65796	94433	131490	191797
11.1 Formulation of Flux/Solder (Moderate Exposure)	119229	142270	186480	250730	370065	561967	813854
11.3 Formulation of Flux/Solder (High Exposure)	39092	42627	50277	67361	96702	134743	196531
12.3 Use of Flux/Solder (Moderate Exposure)	222576	302353	482613	653925	1028773	1993909	2820626
12.1 Use of Flux/Solder (Highest Exposure)	221704	300817	479160	649188	1020530	1971119	2789416

- MOEs represent risk from aggregate exposure values from inhalation ADR and background general population (non-air) exposure.

- Bold text/red shading indicates MOE is less than the benchmark MOE. Non-bold/non-shaded text indicates the MOE is greater than the benchmark MOE.

Recycling of Electronics Waste Containing HIPS

EPA estimated central tendency and high-end air releases of HBCD from electronics recycling sites to be 0.024 and 0.38 kg/site-d, respectively, for a duration of 250 days (Section 2.2.14). EPA compared the air release estimates for this COU to those that were previously used to quantify HBCD air inhalation exposure to the highly exposed general population from releases associated with current conditions of use (Appendix F.1.2). The daily release amounts of HBCD are significantly less than would result in risk based on assessed releases from current uses. For subscenario 5.7, which had the highest exposure of any OES subscenario, daily release of HBCD was 14 kg/site/day using the higher value for emission factor, resulting in an acute MOE of 680 (compared to a benchmark of 100, see Table 4-22). The high-end air releases estimate from electronics recycling is only 0.38 kg/site/day, almost 40-fold less than that of subscenario 5.7. Based on risk estimates above the benchmark for this and all other subscenarios from acute exposure (and no instances of risk estimated for chronic air inhalation exposure), risks are not expected for the highly exposed general population from recycling of electronics waste containing HIPS. Water releases from this OES are not expected and therefore risks via fish ingestion are not relevant to this exposure scenario.

Consumer Articles

Risks were also estimated for consumer articles. These use scenarios are specific to the highly exposed general population and involve exposure to HBCD dust and indoor air. See Section 2.4.4 for more detail on these exposure scenarios. Scenario C1 corresponds to exposure scenario #8, *Installation of XPS/EPS foam insulation in residential, public and commercial buildings, and other structures*, and scenario A4 corresponds to exposure scenario #7, *Installation of automobile replacement parts*.

MOEs were calculated incorporating the summation of these exposures and background general population non-dust, non-air exposures. Results are presented in Table 4-23.

Table 4-23. Risk Estimation for Non-Cancer Effects Following Acute Exposure to Highly Exposed Populations - Consumer Articles

POD_{HED} (mg/kg) = 9.03							
Developmental Toxicity - F2 Offspring Loss							
Benchmark MOE = 100							
SCENARIO NAME	Age Group / Lifestage						
	<1 year	1- <2 years	2- <3 years	3- <6 years	6 - <11 years	11- <16 years	16- <70 years
C1 - XPS/EPS Insulation in residences	35411	41456	49008	65906	103663	191193	285083
C2 - HBCD contained in automobile components	11259	13163	15814	21297	35551	83611	128816
- MOEs represent risk from aggregate exposure values from combined dust and indoor air ADR along with background general population (non-air/non-dust) exposure. - Non bold/ non shaded text indicates the MOE is greater than the benchmark MOE.							

Additionally, EPA estimated risks to the most sensitive lifestage of 0 to <1 year old infants based on *Mouthing of Plastic Articles Containing HBCD* (see Table 2-109 for exposure values). For the highest modeled acute exposure dose of 1.86E-02 mg/kg-day, when summed with central tendency aggregate background exposure the total exposure is 1.86E-2 mg/kg-day, and MOEs are several fold above the benchmark MOE (MOE = 485, benchmark MOE = 100).

4.2.3.3.2 General Population Risk Estimation for Non-Cancer Effects Following Chronic Exposures – Highly Exposed Populations

Risks to the highly exposed population were calculated for non-cancer effects following chronic exposures based on fish ingestion and inhalation. In addition to calculating risks for individual lifestages, risks were calculated for an individual living near a facility across multiple lifestages. The upper-end estimate of residential mobility of 33 years was selected for a high-end exposure duration ([U.S. EPA 2011b](#)). A central tendency value of 12 years was also selected ([U.S. EPA 2011b](#)), with risks calculated both from birth through 12 years of age. Exposure is higher for younger lifestages, so estimating risk for a resident starting from birth is protective of anyone for whom exposure began later. The calculated MOEs based on integrated exposure across lifestages for these durations represent estimations of the risk based on a weighted average of lifestage-specific exposures across the stated period of time. As an example, for residency from birth to 12 years old, integrated fish ingestion exposure is calculated as: $(1/12 * [\text{high-end aggregated general population infant exposure}] + 1/12 * 1\text{-}2 \text{ year old exposure} + 1/12 * 2\text{-}3 \text{ year old exposure} + 3/12 * 3\text{-}6 \text{ year old exposure} + 5/12 * 6\text{-}11 \text{ year old exposure} + 1/12 * 11\text{-}16 \text{ year old exposure})$. A similar weighted average was applied for 33-year residency.

Risks via Fish Ingestion / Dietary Exposure

Risks were not estimated for the following exposure scenarios via dietary exposure because releases were not identified or associated exposures were not quantified:

OES #7, *Installation of Automobile Replacement Parts*

OES #11, *Formulation of Flux / Solder Paste*

A description of all subscenarios for OES resulting in fish ingestion exposure can be found in Table 2-54.

Highly Exposed Population

Infants

Infants <1 year old are not expected to ingest fish in their diet ([U.S. EPA 2011b](#)) (as discussed in Section 2.4.2). Therefore, dietary risks to highly exposed infants were estimated based on high-end aggregate general population exposure values, which incorporates breast milk in its dietary component as well as high-end estimates of dust, dermal, air, and soil exposure. Infant risks are based on steady-state exposures estimated via biomonitoring and are not associated with a particular condition of use. MOEs are several orders of magnitude above the benchmark MOE (MOE 9,959; Benchmark MOE = 300) based on 95th percentile aggregate exposures (Table 4-19).

EPA also modeled infant exposures up to and exceeding the 99.5th percentile and compared those with available biomonitoring data (see Section 2.4.6.1). Estimation of the risk is above the benchmark MOE even for the highest-end exposures (MOE = 468, benchmark MOE = 300), where the maximum modeled HBCD dose is combined with the lower (90th) assumed percentile for the high-end of the underlying distribution of environmental monitoring data. In this circumstance, the maximum estimated dose is 3.59E-3 mg/kg-day (Table 2-110). This risk estimate should therefore be protective of the vast majority of infants within the highly exposed general population.

Other lifestages

Table 4-24 provides risk estimates for each occupational scenario and life stage following acute HBCD exposure (as the sum of chronic fish ingestion dose (ADD) and central tendency non-fish pathway dose) based on the most sensitive hazard endpoint of thyroid effects. ADD values representing chronic

exposure utilized central tendency fish ingestion rates, which are expected to be more representative of most populations over a sustained period. Fish concentrations were estimated based on 21-day average dissolved HBCD in the water column and estimated BAF values, the same as for ADR estimates, except ADD estimates used a 50th percentile stream flow rate which is expected to be more representative of variance over a full year. Integrated exposure across lifestages incorporated the high-end (95th percentile) aggregate exposure value for infants and high-end adult ADD. See Section 2.4.3.2 for a full description of the fish ingestion exposure assessment. Scenario-specific discussions of risk are below.

Table 4-24. Risk Estimation for Non-Cancer Effects Following Chronic Exposure to Highly Exposed Population - Fish Ingestion

Thyroid Effects - Decreased T4 Levels									
POD_{HED} (mg/kg) = 1.68; Benchmark MOE = 300									
SCENARIO NAME	Age Group / Lifestage							Residency across lifestages	
	1- <2 years	2- <3 years	3- <6 years	6 - <11 years	11- <18 years	16- <70 years (CT residency)	16- <70 years (HE residency)	Birth-12	Birth-33
	1.5 Repackaging of Import Containers (Moderate Exposure)	13493	17342	20592	23615	42650	59420	23148	19574
1.7 Repackaging of Import Containers (Highest Exposure)	3314	4070	4732	5210	9328	12945	4776	5109	5208
2.11 Compounding of Polystyrene Resin to Produce XPS Masterbatch (Moderate Exposure)	42626	63202	81016	110413	207932	295491	160615	52906	93777
2.3 Compounding of Polystyrene Resin to Produce XPS Masterbatch (Highest Exposure)	32594	45899	57123	72452	133941	188653	86982	42572	65066
3.4 Manufacturing of XPS Foam using XPS Masterbatch (Moderate Exposure)	48741	74677	97669	140399	268363	384179	245238	58716	114345
3.3 Manufacturing of XPS Foam using XPS Masterbatch (Highest Exposure)	15499	20103	23978	27744	50205	70010	27625	27982	26721
4.2 Manufacturing of XPS Foam using HBCD Powder (Moderate Exposure)	52951	83034	110228	165280	319898	460850	346407	62521	130170
4.1 Manufacturing of XPS Foam using HBCD Powder (Highest Exposure)	27971	38498	47322	58360	107161	150451	65798	37437	53551
5.8 Manufacturing of EPS Foam using Imported EPS Resin beads (Moderate Exposure)	5376	6663	7778	8629	15476	21492	8008	8184	8577
5.7 Manufacturing of EPS Foam using Imported EPS Resin beads (Highest Exposure)	587	712	824	898	1605	2225	811	920	904
6.4 Manufacturing of SIPs and Automobile Replacement Parts (Moderate Exposure)	43862	65462	84244	115979	219015	311659	174116	54109	97727
6.7 Manufacturing of SIPs and Automobile Replacement Parts (Highest Exposure)	23422	31533	38318	46085	84125	117784	49341	32129	43104
8.4 Installation of Insulation in Buildings (Moderate Exposure)	46588	70551	91604	129105	245391	350313	209658	56710	106800
8.3 Installation of Insulation in Buildings (Highest Exposure)	17074	22309	26704	31122	56408	78718	31393	24265	29811
9.4 Demolition and Disposal of XPS/EPS Foam (Moderate Exposure)	22163	29660	35930	42931	78251	109483	45377	30613	40355
9.3 Demolition and Disposal of XPS/EPS Foam (Highest Exposure)	3388	4162	4840	5330	9545	13246	4889	5221	5327
10.3 Recycling of EPS Foam (Moderate Exposure)	34063	48323	60386	77322	143281	202036	94958	44152	68932
10.7 Recycling of EPS Foam (Highest Exposure)	20463	27165	32774	38826	70629	98730	40366	28533	36734
12.2 Use of Flux/Solder Paste (Moderate Exposure)	56195	89745	120590	187483	366992	531767	478246	65352	143436
12.6 Use of Flux/Solder Paste (Highest Exposure)	54800	86828	116056	177570	345834	499805	412935	64145	137608

- MOEs represent risk from aggregate exposure values from fish ingestion ADR and background general population (non-fish ingestion) exposure.

- Non bold/ non shaded text indicates the MOE is greater than the benchmark MOE.

Risks via Inhalation

Risks were not assessed for the following exposure scenarios via dietary exposure because releases were not identified or associated exposures were not quantified:

OES #7, *Installation of Automobile Replacement Parts*

A description of all subscenarios for OES resulting in outdoor air inhalation exposure can be found in Table 2-55 and ADD ranges are provided in Table 2-104. Chronic inhalation risks are based on ADD exposures of community average annual air concentrations, between 100 and 1000 meters from the source. See Section 2.4.3.3 for a full description of the air inhalation exposure assessment. Estimated chronic exposures (ADD + background) for all subscenarios and lifestages were below 1E-4 mg/kg, which corresponds to an MOE of 16,800 for the most sensitive chronic endpoint of thyroid effects. Therefore, the MOE is multiple orders of magnitude above the benchmark MOE for all lifestages of the highly exposed population via inhalation following chronic exposures from any exposure scenario.

Consumer Articles

Risks were also calculated for consumer articles. These use scenarios are specific to the highly exposed general population and involve exposure to HBCD dust and indoor air. See Section 2.4.4 for more detail on these exposure scenarios. Scenario A3 corresponds to exposure scenarios #8, *Installation of XPS/EPS foam insulation in residential, public and commercial buildings, and other structures*, and scenario A4 corresponds to exposure scenario #7, *Installation of automobile replacement parts*.

MOEs were calculated incorporating these exposures and background general population non-dust, non-air exposures. Results are presented in Table 4-25.

Table 4-25. Risk Estimation for Non-Cancer Effects Following Chronic Exposure to Highly Exposed Populations - Consumer Articles

POD _{HED} (mg/kg) = 1.68 Thyroid Effects - Decreased T4 Levels Benchmark MOE = 300							
SCENARIO NAME	Age Group / Lifestage						
	<1 year	1- <2 years	2- <3 years	3- <6 years	6 - <11 years	11- <16 years	16- <70 years
C1 - XPS/EPS Insulation in residences	22722	25427	38428	49422	76353	133286	187090
C2 - HBCD contained in automobile components	52020	48691	56935	70657	103592	154935	209924
- MOEs represent risk from aggregate exposure values from combined dust and indoor air ADR along with background general population (non-air/non-dust) exposure. - Non bold/ non shaded text indicates the MOE is greater than the benchmark MOE (risk not identified).							

Additionally, EPA estimated risks to the most sensitive lifestage of 0 to <1 year old infants based on *Mouthing of Plastic Articles Containing HBCD* (see Table 2-109 for exposure values). For the highest modeled acute exposure dose of 2.01E-03 mg/kg-day, when summed with central tendency aggregate background exposure the total exposure is 2.05E-03 mg/kg-day, and the MOE is almost 3-fold above the benchmark MOE (MOE = 819, benchmark MOE = 300).

4.2.3.4 Targeted Sensitivity Analysis

Section 2.2.15 describes the context behind conducting a targeted sensitivity analysis based on production volume. Briefly, due to the uncertainty with the imported volume and resulting estimates of

environmental releases and exposures to the general population and the environment, a targeted sensitivity analysis on the impact of import volumes on environmental risk estimates was conducted. The exposure scenarios considered in the sensitivity analysis represent the exposure scenarios that resulted in the highest estimates of releases on a daily basis and include scenarios that rely on both industry data and OECD ESDs. Originally as presented above in Section 4.1.4.2, all nine exposure scenarios with estimated water releases containing HBCD were predicted to have production volumes up to 100,000 lbs/yr. The purpose of the sensitivity analysis is to evaluate how the model parameters of production volume and percent of HBCD removed in exposure scenarios with direct releases into surface water may impact the predicted fish ingestion exposure values. In addition to the risk estimates described throughout Section 4.2.3 based on a production volume of 100,000 lbs/yr, risk estimates were also derived using the production volumes of 50,000 and 25,000 lbs/yr for the following three processing exposure scenarios: exposure scenario #1: *Repackaging of import containers*, exposure scenario #2: *Manufacturing of XPS Foam using XPS Masterbatch*, and exposure scenario #3: *Manufacturing of EPS Foam from Imported EPS Resin Beads*.

Estimation of the risk to highly exposed general population via fish ingestion was below the benchmark MOE only for the higher sub-scenario of exposure scenario #5, *Manufacturing of EPS Foam from Imported EPS Resin Beads*. The highest exposure sub-scenario for that exposure scenario, 5.7, assumed direct discharge and 0% WWT removal. A sensitivity analysis based on estimated production volume was performed only for that sub-scenario. Results are provided in Table_Apx K-1.

Manufacturing of EPS Foam from Imported EPS Resin beads

Estimation of the risk is below the benchmark MOE for all lifestyles only following acute exposure from the highest exposure sub-scenario (5.7). Reduced PV has essentially no effect on acute exposures and associated risk estimates.

4.3 Assumptions and Key Sources of Uncertainty for the Risk Characterization

4.3.1 Assumptions and Key Sources of Uncertainties for the Environmental Risk Characterization

In characterizing the environmental risk of HBCD, the same uncertainties mentioned above regarding environmental hazard characterization also apply. Specifically, the uncertainty regarding the diastereomer composition of HBCD will differ based on commercial and consumer products used, and the changes of such proportions that may incur following environmental release.

For evaluating the potential trophic transfer of HBCD in the environment, many assumptions and uncertainties were taken into consideration due to the complexity of food web dynamics. In general, there is an inherent uncertainty when using proxy organisms to represent all terrestrial and aquatic prey and predators; the selection was based on data availability, thus making it difficult to represent more than three levels of prey-predator relationships. Organism selection for this evaluation was exclusively from the available exposure factors in the U.S. EPA Wildlife Exposure Factors Handbook (also incorporated in the U.S. EPA Final Water Quality Guidance for Great Lakes System). The representative organisms used to evaluate trophic transfer in this Risk Evaluation also only represent a small subset of prey-predator relationships and trophic levels within a food web and this evaluation does not quantify how varying prey selection factors will ultimately affect the trophic transfer of HBCD. Variations in diet categories due to life stage, gender, and seasonal differences are not addressed in this evaluation because the specificity of each exposure factor differed based on the methodologies used in

their respective original references. Further, the inability to account for complete diets and the potential variations in diet may have resulted in the under- or overestimation of HBCD uptake, metabolism and elimination. Specifically, there is also an uncertainty regarding the impact of gut physiology on HBCD uptake by prey and predator organisms used in this evaluation; as gut physiology and microbiology becomes more complicated and diverse as the trophic level increases, there is an inherent likelihood that the extent of HBCD uptake and depuration will be affected. Further underestimations of HBCD uptake by terrestrial predators, as compared to aquatic predators in this assessment (*i.e.*, calculated by evaluating kestrel ingestion of mice) may also be due to the use of fruit and grasshopper HBCD biomonitoring data as the original source of HBCD for kestrel, as opposed to smaller mammals with a higher body fat composition. The limited data regarding HBCD in terrestrial organisms contributes to the uncertainty regarding HBCD trophic transfer in terrestrial food webs. Underestimations of HBCD uptake may have resulted from the inability to account for a majority of diet compositions for various predators due to an overall lack of information on such species-specific preferences, and an inability to account for varying sources of physiological differences amongst organisms. The evaluation of trophic transfer may also overestimate uptake of HBCD from a specific prey type because HBCD metabolism and elimination were not accounted for. Furthermore, the inability to quantify spatially- and temporally-related trends regarding HBCD releases and exposure may explain why birds of prey have varying body burdens of HBCD in urban and remote regions ([Law et al. 2006](#); [de Boer et al. 2004](#)). Finally, exposure to terrestrial organisms may be underestimated because exposure via the inhalation of suspended HBCD particulate in the ambient air (from various release sources) was not characterized or aggregated with exposure to soil or ingestion (*i.e.*, diet). Only one available repeat-dose toxicity study was evaluated where no adverse effects were observed up to 2000 mg/m³ administered 6h/day for 14 days, and the reported LC50 for 4-h inhalation exposure in rats is greater than 5000 mg/m³ ([Song et al. 2016](#)). As seen in Appendix F.3, the highest modeled air releases of HBCD are from exposure scenarios for import/repackaging (2.18×10^{-2} mg/m³) and manufacturing of EPS foam from imported EPS resin beads (2.28×10^{-2} mg/m³) for fence-line communities (100 m from the source), which are five magnitudes less than the hazard thresholds observed for rats due to inhalation. Therefore, inhalation of HBCD may not be the main driver for HBCD exposure for terrestrial organisms, even those that inhabit areas near industrial facilities.

EPA assessed releases of HBCD to the environment or to disposal based on the production volume of HBCD, emission factors, and number days of release per year. In a few cases, EPA used TRI release data in lieu of the production volume of HBCD and emission factors. The emission factors were obtained from the EURAR, OECD ESDs, an EPA GSs, or a scientific journal article and the number of days of release per year were obtained from the EURAR, EU TGD, the NICNAS RAR, an OECD ESD, or an EPA GS as discussed in detail in Section 2.2. These data do not specifically pertain to the sites that are the subject of this Risk Evaluation. Therefore, in the case of each COU, EPA estimated a range of emission factors and a range of number of days of release per year and calculated a range of daily release rate from these estimated ranges to account for uncertainty about the values of the emission factor and number of days of release. Also, in the case of some releases, there is uncertainty about medium of release and therefore EPA assessed various media of release to account for this uncertainty. The emission factors and numbers of days of release per year that are the basis of the assessment pertain to HBCD processing or use that occur at sites that are not located in the U.S. or pertain to an industrial or commercial sector that is related to a COU (*e.g.*, polymer processing, use of spray polyurethane foam). There is some uncertainty regarding the extent to which this data is applicable to processing or use of HBCD in the U.S. To account for the uncertainties and variability among release estimates and exposure considerations including wastewater treatment, EPA provided risk estimates based on a range of exposure sub-scenarios. EPA believes this sufficiently captures the range of risk estimates for all reasonably expected environmental exposures. In regard to the calculation of risk estimates using

predicted surface water or sediment concentrations of HBCD based on E-FAST or the PSC, all risk estimates can be associated with a specific condition of use.

Water dilution models can be used to determine the concentration of a chemical in the surface water after a source emits the chemical into a water body. Since the E-FAST model incorporates defaults that encompass either a combination of upper percentile and mean exposure parametric values, or all upper percentile parametric values, the resulting model predictions represent high-end exposures estimates. Simple dilution models, such as EFAST provide exposure estimates that are derived from a simple mass balance approach, and does not account for partitioning between compartments within a surface water body or degradation over time in different media, parameters which are relevant to HBCD, therefore EPA utilized a two-tier approach by complementing the EFAST modeling with more refined estimate from the PSC model to further describe environmental exposures. However, these predicted surface water and sediment concentrations will likely underestimate HBCD concentrations because they do not take into consideration background HBCD concentrations (only what may be in these matrices due to water releases containing HBCD from a specific condition of use).

Monitoring data on measured water, sediment, and soil concentrations of HBCD take into consideration real time HBCD concentrations in these matrices, however they cannot be associated with a specific release associated with historical or condition of use. Some monitoring studies will associate measurements to a specific sector; however this categorization is still too broad for one to associate with a historical or condition of use. Furthermore, although risk estimates can be condition of use- or sector-specific, the sole use of surface water, sediment, and soil concentrations of HBCD will not account for dietary-associated sources of HBCD and will underestimate the risk to both terrestrial and aquatic organisms. Aggregation of HBCD exposure pathways was not conducted within an exposure pathway (*e.g.*, the summation of sediment HBCD exposure to benthic organisms from via both background monitoring data and potential modeled current releases from an ongoing condition of use) or across exposure pathways (*e.g.*, diet, dermal, inhalation) to avoid double-counting because exposure via a particular route is likely geographically specific and risk estimates are only based on specific exposures. Measured background exposure concentrations are therefore potentially associated with releases from both historical and current conditions of use, and may be used to semi-quantitatively evaluate exposure should there be predicted releases. As discussed in Section 4.1.3, measured monitoring information (background exposure) was used to characterize the risk to aquatic and terrestrial organisms due to potential surface water and air releases of HBCD from the land disposal of other formulated products and articles (*e.g.*, adhesives, coatings, textiles, and electronics) via potential leaching and runoff of HBCD, in lieu of having measured data. As stated previously, measured monitoring information can encompass releases from all historical and current conditions of use, therefore the use of monitoring information (background exposure) may overestimate contributions from this one exposure scenario.

For exposure scenarios where water and/or air releases were not predicted to occur, EPA does not expect that commercial or consumer uses of products or articles containing HBCD will lead to releases to the environment, however EPA cannot rule out this possibility. Any potential environmental exposure resulting from ambient air releases of commercial/consumer products is expected to be captured as part of the background assessment of environmental soil monitoring data near general population (non-point source exposure) sites (Table 4-6).

Based on the HBCD releases resulting from exposure scenario 5.8 (EPS foam from imported EPS Resin; input parameters further detailed in Section 2.2.6), using the 10th percentile predictions, an additional sensitivity analysis was conducted to evaluate how a greater range of HBCD aerobic benthic half-lives (*i.e.*, 6-, 8-, 32-, 100-, 384-d) would affect PSC-predicted surface water and sediment HBCD concentrations, in comparison to the analysis conducted in the Risk Evaluation using both the 11- and

128-d HBCD aerobic benthic half-lives. 11- and 128-d HBCD half-lives represent a selected range of HBCD aerobic benthic half-lives and are based on the high data evaluation scores. Predicted surface water HBCD concentrations are based on the HBCD half-life of 128-days, and predicted sediment HBCD concentrations are based on both 11- and 128-d HBCD half-lives.

In regard to the 21-d average surface water and 28-d average sediment HBCD concentrations, there is an average difference of 3% and 19.5%, respectively. The average difference between surface water and sediment concentration ranges are 0.85-6.4, and 4.7-41.1%, respectively. In addition, the greatest difference between predicted 21-d average surface water and 28-d average sediment HBCD concentrations was when comparing the 11-, 32-, and 100-d HBCD aerobic benthic half-lives (average difference in surface water and sediment HBCD concentrations of approximate 6%, and 18-41%, respectively). When comparing the lowest and highest predicted HBCD surface water and sediment concentrations using either the 6- or 384-d HBCD half-lives, there is a difference of 17.7 and 76.1% in HBCD surface water concentration (19.9-24.2 $\mu\text{g HBCD/L}$) and HBCD sediment concentration (15,600-65,200 $\mu\text{g/kg}$), respectively. Based on the average difference between the surface water and sediment concentrations of HBCD due to the various half-lives presented in the sensitivity analysis, selecting a different half-life only significantly impacts the sediment concentration (*i.e.*, a longer half-life results in higher HBCD sediment concentrations). The sensitivity analysis suggests that there is a significant amount of uncertainty in regards to the exposure scenario-specific environmental risk based on PSC-predicted sediment concentrations; given that HBCD is likely to partition to sediment, it is likely that the current values underestimate sediment HBCD concentrations and resulting risk to benthic organisms, especially since these calculations do not take into consideration background levels of HBCD that pre-exist potential exposure scenario-specific releases. Finally, model-predicted media concentrations do not take into consideration previously-released HBCD via historical or current conditions of uses, and underestimate the overall HBCD exposure to aquatic or terrestrial organisms.

The degradation of plastic products in the environment has also resulted in concern regarding the uptake of HBCD via exposure to microplastics. As discussed in Section 2.1.3, this evaluation does not quantify exposure to microplastics, nor is it able to quantify potential of exposure to HBCD from microplastics due to various factors impacting microplastic fate and transport, as well as those impacting the possible desorption of HBCD from microplastics if ingested (*i.e.*, physiological limitations to prey size, gut physiology, microplastic physical-chemical properties). Microplastics, similar to other environmental sorbents (*i.e.*, natural organic matter, suspended solids) are able to act as both a source and sink of hydrophobic contaminants, and introduce uncertainty to the Risk Evaluation of HBCD exposure and risk to aquatic and terrestrial organisms due to the complexity involved in the characterization of both microplastic and microplastic-associated contaminant bioavailability. The approach used here to estimate release and exposure does not account for the fact that HBCD may be released in a polystyrene matrix in the modeled exposure scenarios. The inability to quantify potential leaching of HBCD from products containing HBCD may overestimate or underestimate HBCD environmental exposure in various media.

Another uncertainty regarding the exposure and environmental risk of HBCD is the likelihood of sex-specific transfer of HBCD to offspring. HBCD has been measured in peregrine falcon and chicken eggs upwards of 15,000 and 5,800 ng HBCD/g lw ([Tao et al. 2016](#); [Guerra et al. 2012](#)). In addition, HBCD has also been quantified in milk from both humans and dairy cows (10 and 5.3 ng HBCD/g lw, respectively) ([Shi et al. 2017b](#); [Glynn et al. 2011](#)). The presence of HBCD in the eggs of both aquatic and terrestrial birds, as well as the milk of terrestrial mammals, suggests that sex-specific transfer is an elimination pathway of HBCD for female birds and mammals that are reproductively active and resulting offspring are exposed to HBCD before and after birth. The Risk Evaluation does not take this

uncertainty into account, and it is likely that the current environmental Risk Evaluation underestimates organism exposure to HBCD.

EPA assessed risks for many of the current uses of HBCD using an assumed annual production volume of 100,000 lbs per site (Section 2.2.1). EPA considers this value to be an upper bound estimate for an importer based on the 2016 CDR reporting estimates and small entity reporting requirements. Considerably higher production volume (ranging as high as 10 to 50 million pounds) occurred in previous years. Many of the previously manufactured products associated with this past production may still be in use and therefore be contributing to current and future levels of release. There is insufficient information available for EPA to quantify any additional level of current or future releases from the COUs based on this past production. As previously stated, the 100,000 lbs/year-site value that EPA used for the primary assessment may represent a conservative approach for current production, however, the possibility of higher releases based on remnants of past and historical activities cannot be ruled out. As stated above in Section 4.1, EPA performed a sensitivity analysis for three COUs (Repackaging of Import Containers, Manufacturing of XPS foam from XPS masterbatch, and Manufacturing of EPS foam from EPS resin) using the per site volumes of 50,000 lbs/yr and 25,000 lbs/yr to examine the effect of process volume on modelled environmental exposures. Due to HBCD declining use, EPA did not identify a current import volume for HBCD, and conservatively used the CDR reporting threshold for small firms of 100,000 lbs/yr as explained in Section 1.2.3.

As previously discussed, historical activities are responsible for a subset of the total aggregate exposure to the environment and general population. The specific percentage of these total exposures that stem from historical activities cannot be determined and may differ both geographically and temporally.

4.3.1.1 Confidence in Risk Estimates

There are many sources of uncertainty confidence in the parameters used to estimate surface water and sediment HBCD concentrations for each exposure scenario. As presented in Table 2-113, the uncertainty and variability are summarized for each consideration regarding environmental releases, fate, and exposure model parameters, including in some cases the multiple sources of information used for some of these considerations (*i.e.*, emission factors, days of release, physical-chemical properties). To account for these sources of uncertainty and variability, EPA provided risk estimates that reflect a range of considerations, resulting in multiple iterations of RQs (exposure sub-scenarios) for each exposure scenario.

EPA believes that these sub-scenarios sufficiently capture the range of risk estimates for all reasonably expected aquatic and terrestrial exposures, with minimal remaining unaccounted-for uncertainty. The environmental monitoring and biomonitoring studies used to derive risk estimates are of high quality and are used to evaluate background concentrations of HBCD and the potential for HBCD trophic transfer in aquatic (osprey, mink and other fish-consuming predators) and terrestrial organisms. Although the organisms covered in these analyses are limited and do not take into consideration variabilities in diet preferences, similar to the selected hazard effect concentrations used to derive risk, representative organisms were used; whether exposure is assessed using measured or predicted media or tissue concentrations, there is generally greater risk calculated for aquatic organisms. Therefore, EPA has high confidence in the range of risk estimates for both aquatic and terrestrial organisms.

4.3.2 Assumptions and Key Sources of Uncertainties for the Human Health Risk Characterization

4.3.2.1 Physical-Chemical Properties and Toxicokinetics Considerations

HBCD toxicokinetics including absorption and bioaccumulation differ greatly among the three HBCD isomers (α -, β -, and γ -HBCD) and are greatly affected by the relative fat content of tissues and surrounding media (*e.g.*, water, air, diet, breastmilk). Reasonably available information on human health hazard and exposure does not typically differentiate among the three isomers of HBCD, and it is unknown whether a particular COU or exposure pathway may bias toward one isomer over another. In the absence of reasonably available information, this Risk Evaluation only assessed HBCD as a variable mixture and it cannot be determined whether how the risk estimates would compare to a more refined isomer-specific assessment.

EPA estimated dermal risks assuming consistent 6.5% dermal absorption based on the highest-end estimate from available *ex vivo* and *in vitro* data in order to be health-protective. The actual percentage of HBCD absorbed dermally is variable based on multiple factors including the relative percentage of each isomer in the mixture and the relative ratio of sweat to sebum on skin. Absorption in occupational settings may be substantially lower than this value based on frequent hand washing or uneven distribution across skin. The true percentage of any dermally delivered dose that would be systemically absorbed is likely to vary between COUs and over time. A calculation of flux would account for the effect of exposure duration on absorbed dose. However a quantitative comparison demonstrates that fraction absorbed and permeability/flux methods result in approximately the same value when using upper-bound estimates (Appendix L). For many COUs HBCD is expected to be entrenched within granules or pellets for which absorption is not expected. This will significantly reduce the amount of HBCD absorbed from within these materials. However, for most COUs the MOEs were more than an order of magnitude below the benchmark MOE, so moderate refinements in dermal absorption are unlikely to result in a different risk conclusion.

EPA did not evaluate potential risks to metabolites or degradants of HBCD. *In vivo* metabolism of HBCD varies by stereoisomer (Section 3.2.2.1.3) and the expected distribution of resulting products cannot be sufficiently quantified. Any toxicity from HBCD metabolites would likely be accounted for in long-term animal studies on the parent compound. Environmental or industrial degradants (*e.g.*, from thermal cutting) are expected to be similarly diverse and there is insufficient information available for accurately determining relative concentrations of any particular species given differing assumptions about media of release, wastewater treatment, and fate. Uncertainty is compounded when considering the limited availability of toxicological data on these potential degradants. It is unknown how much additional risk can be attributed to these species.

Thermal cutting of XPS and EPS foam with a hot wire can result in the release of HBCD nanoparticles (Section 2.4.1.1). In addition to potentially increased absorption, nanoparticles may have unique toxicities independent of HBCD biochemistry. EPA cannot determine sufficient details on the nature of these nanoparticles or what additional toxicity they may present. Additionally, EPA did not incorporate HBCD nanoparticle air concentration data into the estimates of exposure concentrations of the relevant exposure scenarios because these data are measurements of concentration in a laboratory glovebox and are not worker monitoring data. The absence of quantitative risk estimates for nanoparticle toxicity represents a potential underestimation of risk from exposure to HBCD from these uses.

Although some simplistic toxicokinetic models for HBCD exist (empirical two-compartment open kinetic model; and a simple first-order elimination model to estimate the steady-state lipid

concentration); these models introduce significant uncertainties that reduce the value of their use. Therefore, EPA was unable to model the potential effects of bioaccumulation in human tissues over time. For both consistency and health-protectiveness, these issues were accounted for by utilizing the upper range of absorption estimates across available studies and including a 10X subchronic-to-chronic UF based on assumed increasing bioaccumulation over time. This adjustment was not included for developmental endpoints or for effects observed following multi-generational exposure, which should already encompass chronic bioaccumulation. EPA also conservatively evaluated risks to all receptors from hazards only observed in the F2 population (*i.e.*, only after 2 generations of bioaccumulation). EPA believes that the use of this 10X uncertainty factor is likely to be protective of risk from bioaccumulation in human tissues, however there is insufficient available data to confirm this presumption.

4.3.2.2 Human Health Hazard Considerations

To derive the benchmark MOEs, the UF approach ([U.S. EPA 2000b](#); [U.S. EPA 1994](#)) was applied to a POD_{HED} based on changes in thyroid hormone levels (T4) in male rats exposed to HBCD. UFs were applied to the POD_{HED} to account for extrapolating from an animal bioassay to human exposure, the likely existence of a diverse population of varying susceptibilities, and subchronic to chronic duration (chronic exposures only). For the most part, these extrapolations are carried out with default approaches given the lack of data to inform individual steps. EPA presumes that in general these uncertainty factors are health-protective and are unlikely to underestimate risk relative to more data-driven refinement of uncertainty factors.

As discussed in Section 3.2.5.2.1, both reduced pup body weight and offspring loss were considered as relevant developmental endpoints for evaluating risks following acute exposure. There is substantial uncertainty whether a single exposure can produce a permanent adverse effect on postnatal mortality or body weight. EPA determined that the sustained persistence of HBCD in human tissue suggests that a single exposure could have sustained effects. Additionally, acute and short-term exposure has been associated with thyroid hormone disruption, which would be expected to have downstream effects on development. Therefore, despite the uncertainties, neonatal mortality and body weight reduction were considered relevant to acute exposures. EPA also considered maternal decreases in T4 levels for acute exposure scenarios, because short-term changes in thyroid hormones are likely upstream of those developmental outcomes. Additionally, decreased maternal T4 can serve as a sensitive quantitative measure of other potential developmental effects that cannot otherwise be quantified (such as neurotoxicity). EPA evaluated general population risks for the most sensitive endpoint of offspring loss for all lifestages, including those below reproductive age. While developmental effects would not be expected to present in younger lifestages, the bioaccumulation and persistence of HBCD in tissues suggests that initial exposure at an earlier age could result in effects later in life. Additionally, it is unknown whether developmental effects on neonates could also present in young exposed children. This is a health protective approach that will overestimate risks to the general population following acute exposures, especially for those lifestages below reproductive age. There is substantially less uncertainty for risk estimations of teenagers and adults.

For risks following chronic exposure, there is medium confidence in the risk estimates for most sensitive endpoint of thyroid effects for all populations and lifestages. There is uncertainty over the use of rodent thyroid hormone data for quantitative human health risk assessment, as the complexity of the system makes it difficult to determine whether adult rodents would in fact be more sensitive to the specific effects of HBCD. However, developmental effects of thyroid disruptors following gestational exposure are expected to be highly comparable between rats and humans, with substantially increased susceptibility in developing individuals of both species compared to adults. Direct extrapolation of rodent thyroid hormone effects to humans is health-protective and may potentially overestimate risk to

human adults, but evidence supports its use as a sensitive quantitative endpoint upstream of various detrimental developmental outcomes, including those which could not be quantified (*e.g.*, developmental neurotoxicity).

4.3.2.3 Occupational Exposure Considerations and Confidence Statements

There is high confidence in the most sensitive human health endpoints for chronic and acute exposures, and all endpoints are relevant to workers whom are all likely to be of reproductive age. Occupational inhalation exposure estimates (see Section 2.4.1.15.4) were assigned Low-Medium to Medium confidence (Table 2-71) based on inhalation monitoring data for all OES. Confidence is raised by the evaluation of risk estimates using both central tendency and high-end exposure levels. Therefore, estimated risks for occupational exposures are overall of medium confidence for OES with low-medium exposure confidence and of medium-high confidence for all OES with medium confidence.

In the absence of data, the dermal exposures to workers for relevant COUs were estimated using a dermal exposure model routinely used in the new chemicals program, “EPA/OPPT Direct 2-Hand Dermal Contact With Solids.” The dermal exposure levels were estimated using conservative assumptions, however both high-end and central tendency dermal exposure was estimated. When considering the variability in expected dermal absorption (see above), it is likely that dermal risk estimates are overestimated for the majority of occupational scenarios. Given the various uncertainties, the potential magnitude of overestimation cannot be determined. There is low-medium confidence in occupational dermal risk estimates.

For the purposes of this evaluation, inhalation and dermal routes of exposure were not combined to evaluate occupational risks to HBCD. Dermal and inhalation exposure were considered independently. Combining exposure routes would entail too much uncertainty as to the actual internal dose at target sites given the lack of a usable PBPK model and/or measured biomonitored doses. See Section 4.4.2 for more discussion.

EPA expects potential inhalation exposure of occupational non-users (ONUs) to HBCD, but EPA did not quantify these exposures due to lack of adequate worker monitoring data and lack of relevant mathematical models as discussed in Section 2.4.1.1. EPA assumes HBCD air concentrations that ONUs are potentially exposed to are lower than HBCD air concentrations that workers are potentially exposed and also assumes the duration and frequency of the ONUs’ potential HBCD inhalation exposures to be lower than that of workers as discussed in Section 2.4.1.1. When risks are not identified for workers, risks are unlikely for ONUs. However, during the construction (*i.e.*, installation of XPS/EPS insulation) and demolition of buildings, there is uncertainty about whether the HBCD potential exposure level of ONUs in the case of construction and demolition workers is in fact lower than those of workers. EPA believes that ONUs may work in close proximity to workers for these OES and hence may be exposed to HBCD air concentrations similarly to workers. Furthermore, the duration and frequency of the ONUs’ work during the construction and demolition of buildings may equal that of the workers at least for limited periods of time. Therefore, risks may be comparable between ONUs and workers for these OES.

EPA is unable to quantify risk estimates for occupational exposure associated with the COU *Land Disposal of Formulated Products and Articles*. While exposures to HBCD from disposal of HBCD-containing articles are expected to be less than that for other OES, in some circumstances municipal solid waste may undergo shredding which can result in significant exposure to dust. Elevated exposures under this scenario are unlikely for a sustained basis, however acute exposure is possible. EPA only considers developmental endpoints as relevant to acute exposure, so presumably acute exposure would only be of concern to a female who is pregnant concurrent with exposure. Therefore, risks from *Land Disposal of Formulated Products and Articles* are unlikely but cannot be ruled out.

4.3.2.4 PPE Considerations

Non-cancer risk estimates (MOEs) for occupational exposure scenarios are presented in Section 4.2.2. These tables also present the minimum respirator requirement needed to mitigate risk for all health domains. The MOEs for these respirator scenarios assume workers are properly trained and fitted on respirator use, and that they wear respirators for the entire duration of the work activity. The MOEs for respirator scenarios following chronic exposure also assume that workers wear respirators for the entire duration of the work activity throughout their career. Similar assumptions apply to the use of gloves and their expected elimination of any dermal exposure.

EPA has considered these assumptions for each condition of use (Table 4-13). The majority of COUs and exposure scenarios are likely to take place in an industrial setting with an effective and robust respiratory protection program. However, for installation and demolition of EPS/XPS insulation products (OES #8 and #9), Based on expert judgment and evaluation of peer review comments, EPA believes that workers in these scenarios are unlikely to wear respirators. Therefore, MOEs assuming respiratory PPE are presented for these OES only as a what-if scenario, but risk estimates without respirators will be used for risk determination. EPA believes that this approach reflects a reasonable application of PPE considerations for each COU.

4.3.2.5 General Population/Consumer Exposure Considerations and Confidence Statements

EPA evaluated risk to the general population for individual lifestages for both acute and chronic exposure scenarios. For chronic exposure, EPA also evaluated risk for an individual living near a facility throughout their lifetime using integrated exposure values across lifestages, representing a weighted average across a lifetime.

Estimated risks to the highly exposed populations are driven by fish ingestion exposure. Therefore, these estimated risks are highly dependent on the selected BAF value. EPA chose a BAF value at the low-end of the reported range. This was done because the modeled dissolved surface water estimates are generally larger than values reported in the literature. Pairing a higher BAF value with higher surface water values could result in unreasonably high estimated fish-tissue concentrations. EPA compared the range of reported fish-tissue concentrations from monitoring data and found the modeled fish tissue concentrations (range of modeled dissolved surface water and low-end BAF) to be of a similar order of magnitude. Therefore, while selection of a different BAF value would have a significant effect on fish ingestion risk estimates, the values for BAF and resulting fish ingestion exposure are well-supported by the data.

For estimating fish ingestion exposures to the highly exposed general population, EPA selected high-end fish ingestion rates for calculation of ADR values in order to represent high-end acute exposures. ADD values representing chronic exposure utilized central tendency fish ingestion rates, which are expected to be more representative of the most populations over a sustained period. While these assumptions are expected to protect the majority of populations, there is potential for higher risk among subpopulations with consistently elevated fish consumption rates. Risk estimates for chronic exposure scenarios may therefore underestimate risk to these subpopulations, however it is uncertain whether any of these subpopulations with significantly elevated fish ingestion rates actually live nearby a HBCD facility. In order to account for subpopulations with consistently elevated fish ingestion rates, EPA also evaluated risks to subsistence fishers (Section 4.2.3.2), however reasonably available and reliable data on ingestion rates were only available for adults (from [U.S. EPA 2000a](#)). The inability to confidently assess younger lifestages underestimates risk to this PESS group.

Estimated days of release for a given OES are assumed to be evenly distributed throughout the year. Additionally, days of release for certain sub-scenarios may be as low as a single day per year. Toxicological data are not available comparing intermittent and continuous exposures for relative chronic health outcomes, but the effects of these uncertainties are minimized due to the sustained environmental persistence and elevated bioaccumulation of HBCD in tissues. Both acute and chronic exposures via fish ingestion to the highly exposed general population are based on 21-day average dissolved HBCD water concentration and a single BAF value. It is assumed that the average HBCD concentration in fish to be consumed remains relatively constant and the more important variable is the ingestion rate, however EPA also assumed 50th percentile flow rate for risk estimates based on chronic exposures. Use of highest single-day water concentrations for acute exposure would provide a more health-protective estimate, however this would introduce large uncertainties and incongruity between the use of chronic BAF values and acute release/exposure scenarios. Similarly, risk estimates resulting from chronic exposures based on 50th percentile flow rate may underestimate risks for certain water bodies with consistently low flow rates, however there would be significant uncertainty whether a 10th percentile flow rate could be valid over an entire yearly average.

EPA does not expect that commercial or consumer uses of products or articles containing HBCD will lead to releases to the environment, however EPA cannot rule out this possibility. Any potential general population exposure resulting from ambient air releases of commercial/consumer products is expected to be captured as part of the aggregate background assessment (Section 4.2.3.1).

There are many potential sources of uncertainty in all of the parameters involved in general population exposure estimates. As presented in Table 2-114, the greatest influence on highly-exposed exposure estimates given the associated uncertainty and sensitivity (effect on the final values) stems from the selection of emission factor and days of release. Production volume is highly uncertain but not very sensitive, while other factors such as physical-chemical properties, BAF, HBCD half-lives, and exposure model parameters were all estimated to contain low uncertainty. In order to account for these uncertainties and variability among release estimates and exposure considerations including wastewater treatment, EPA provided risk estimates based on a range of exposure sub-scenarios. EPA believes that these sub-scenarios sufficiently capture the range of risk estimates for all reasonably expected general population exposures, with minimal remaining unaccounted-for uncertainty. Consumer article modeling defaults are believed to be highly uncertain and highly sensitive, however estimation of the risk for consumer articles were orders of magnitude above the benchmark MOE. Therefore, EPA has high confidence in the range of risk estimates for the highly exposed general population.

Overall, based on the considerations above there is medium confidence in fish ingestion risk estimates. There is high confidence in risk estimates for inhalation exposure and low-medium confidence for consumer articles. Confidence in risk estimates from acute exposure is lower for non-infant lifestages below reproductive age because risk estimates from acute exposure are based on developmental endpoints that are less likely to affect older children.

4.3.2.6 Considerations of Historical Production Volumes and Activities

EPA assessed risks for many of the current uses of HBCD using an assumed annual production volume of 100,000 lbs per site (Section 2.2.1). EPA considers this value to be an upper bound estimate for an importer based on the 2016 CDR reporting estimates and small entity reporting requirements. Considerably higher production volume (ranging as high as 10 to 50 million pounds) occurred in previous years. Many of the previously manufactured products associated with this past production may still be in use and therefore be contributing to current and future levels of release. There is insufficient information available for EPA to quantify any additional level of current or future releases from the COUs based on this past production. As previously stated, the 100,000 lbs/year-site value that EPA used

for the primary assessment may represent a conservative approach for current production, however, the possibility of higher releases based on remaining stockpiles cannot be ruled out.

As previously discussed throughout the Risk Evaluation, both legacy uses (described in Section 1.2.8) and historical activities (described in Section 1.2.9) are responsible for a subset of the total aggregate exposure to the environment and general population. The specific percentage of these total exposures that stem from historical activities cannot be determined and may differ both geographically and temporally.

4.4 Other Risk Related Considerations

4.4.1 Potentially Exposed or Susceptible Subpopulations

This Risk Evaluation included risk estimates for adult workers and female workers of reproductive age in order to account for developmental endpoints and for various lifestages of the general population in order to account for differential exposures. MOEs for female workers of reproductive age were 10% lower than workers overall, however in most instances the risk conclusions were the same. EPA indicated instances in which risk conclusions differed among average workers and female workers of reproductive age in Section 4.2.2. When risk conclusions differ for average workers and women of childbearing age, Table 4-27 presents the risk estimate for the more sensitive subpopulation of women of childbearing age.

Risk estimates were calculated for the highly exposed general population (representing populations living close to a facility with HBCD releases) using the most sensitive relevant POD for both the highest exposure sub-scenario along with a representative moderate exposure scenario. Risk estimates for the highly exposed general population incorporated aggregate background exposure levels in addition to modeled COU-specific exposure pathways. EPA also estimated risks for all lifestages, including the most susceptible lifestages of infants and young toddlers. For dietary risks to infants (who are not expected to ingest fish), risks were estimated for the absolute worst-case scenario of aggregated exposure (including breastmilk) based on biomonitoring data (Section 4.2.3.3.2). EPA additionally evaluated risks to susceptible lifestages from ingestion of house dust or mouthing of plastic articles. An individual can fall into multiple PESS categories. For example, an individual may be highly exposed because they live near a facility and may also be biologically susceptible as a pregnant mother. Alternatively, they may live near a facility and also and be a worker.

For estimating fish ingestion exposures to the highly exposed general population, EPA selected high-end fish ingestion rates for calculation of ADR values in order to represent high-end acute exposures. ADD values representing chronic exposure utilized central tendency fish ingestion rates, which are expected to be more representative of the most populations over a sustained period. While these assumptions are expected to protect the majority of populations, there is potential for higher risk among subpopulations with consistently higher fish consumption rates. For some populations, such as Native American tribes, fish consumption rates may differ from that of the general population, including the highly exposed population. Fish consumption rates among multiple tribes have been investigated, and this information is documented in EPA's Exposure Factors Handbook ([U.S. EPA 2011b](#)) and other publications ([Burger 2002](#); [Critfc 1994](#)). Because ingestion rates vary across tribes, use of a single value for fish consumption rate may over or underestimate exposures. Infants, children and pregnant woman are also groups among Native American tribes and these populations overlap with other potentially exposed or susceptible subpopulations. For populations with higher rates of fish ingestion, this may result in elevated exposure. Additionally, other activities unique to these communities (*e.g.*, open burning, ([Gochfeld and Burger 2011](#))) may lead to additional aggregate exposure pathways which have not been characterized in this

Risk Evaluation. While EPA was unable to provide risk estimates for tribal communities, EPA estimated risk to subsistence fishers (Section 4.2.3.2), a subpopulation that is similarly highly exposed due to increased fish consumption relative to the general population. While fish consumption for certain tribal communities may exceed even that of subsistence fishers, EPA assumes that these risk estimates are applicable to the majority of communities.

4.4.2 Aggregate and Sentinel Exposures

Section 2605(b)(4)(F)(ii) of TSCA requires EPA, as a part of the Risk Evaluation, to describe whether aggregate or sentinel exposures under the conditions of use were considered and the basis for their consideration. EPA has defined aggregate exposure as “the combined exposures to an individual from a single chemical substance across multiple routes and across multiple pathways.” A detailed description of the aggregate exposure evaluation is presented in Section 2.4.2.2.5. The relative contribution of each pathway to the aggregated background exposure is shown in Table 2-88 (central tendency) and Table 2-90 (high-end). As a result of the widespread occurrence of HBCD coupled with its persistence and bioaccumulation, aggregate exposures to the general population including consumers were considered for HBCD by evaluating multiple pathways, routes of exposure and age groups. For all general population exposure routes, background aggregate exposures for all exposure routes were combined with specific modeled exposures for the pathway of interest (*i.e.*, fish ingestion, air inhalation, dust/indoor air, mouthing). Aggregating general population exposures is appropriate because these background exposures are based on monitoring data and account for the persistence of HBCD in biological tissues. While there is significant uncertainty and potential for overestimation of dermal exposure based on use of an upper-end absorption estimate, this is a very minor contribution to the overall general population exposure and the additional dermal contribution is unlikely to overload toxicokinetic processes. For workers however, dermal exposure estimates are significantly higher than inhalation exposure and it would therefore be inappropriate to add a likely highly overestimated value to the inhalation exposure estimates without the use of a PBPK model available for determining the effect on internal dose estimates. Therefore, EPA chose not to employ simply additivity of exposure pathways for workers because of the uncertainties present in the current exposure estimation procedures. Conversely, not aggregating exposures may underestimate total exposure for a given individual. Additionally, background general population exposures were not aggregated with occupational exposures for risk estimation to workers because background general population exposures are orders of magnitude less than occupational exposures and would only have a negligible effect on the overall risk estimates.

EPA defines sentinel exposure as “the exposure to a single chemical substance that represents the plausible upper bound of exposure relative to all other exposures within a broad category of similar or related exposures.” In this Risk Evaluation, EPA considered sentinel exposures by considering exposures to populations who may have upper bound exposures due to their exposure factors (*e.g.*, higher intake rates such as elevated fish consumption), who live in close proximity to point sources associated with the conditions of use and spend time in environments with HBCD-containing building materials or automobile replacement parts. EPA characterized high-end exposures in evaluating both modeled and monitored exposures to various receptors. A description of the high-end exposure estimates is provided in Section 2.4.1.1 for workers. For the general population, risk was characterized for the most highly exposed lifestage (*i.e.*, <1 year olds for dust/inhalation, 1 to <2 year olds for fish ingestion).

4.5 Risk Conclusions

4.5.1 Environmental Risk Conclusions

A summary of risk estimates is provided below for aquatic and terrestrial organisms. Risk estimates presented in tables represent the most robust and sensitive values when accounting for all of the assessed representative species.

4.5.1.1 Summary of Risk Estimates for Aquatic Organisms

As described in Section 3.1.5, the environmental hazard thresholds are based on environmental hazard concentrations reported for both aquatic and terrestrial organisms; environmental risk estimates are ratios that compare the hazard threshold to exposure. Risk estimates for aquatic organisms based on environmental monitoring data (near industrial facilities and general population sites, as categorized by study authors) are summarized for pelagic and benthic organisms above in Section 4.1.4.1 and below in Table 4-26. The average of 90th percentile (high-end) and mean of means (central tendency) surface water and sediment concentrations summarized in Table 4-3 and Table 4-4, respectively, are used to calculate risk for aquatic organisms that inhabit ecosystems near industrial facilities (point source) or general population (non-point source) sites. Specifically, the high-end and central tendency surface water concentrations measured near industrial facilities or general population sites were compared to all three pelagic COCs: algae (1 µg/L), acute fish (0.4 µg/L) and chronic water flea (0.42 µg/L). The algae COC is based on observed reductions in growth rate as a result of a 72-hour exposure to HBCD. The acute COC is based on delayed zebrafish embryo hatching as a result of a 96-hour exposure to HBCD and the chronic water flea COC is based on reduced growth in surviving young. For characterizing risk to benthic organisms, high-end and central tendency sediment concentrations measured near industrial facilities or general population sites were compared to the 28-d blackworm chronic COC (1,570 µg/kg), based on effects on reproduction and mortality after a 56-day exposure. Summarized below in Table 4-26, RQs were equal to or above 1 (denoting risk) for all three COCs for pelagic organisms (algae, acute fish and chronic invertebrate COCs), and the one COC for benthic organisms (chronic invertebrate COC) based on measured surface water and sediment concentrations near industrial facilities, respectively. On the other hand, RQs were less than one for all aquatic organisms based on environmental monitoring data attained near general population sites.

Table 4-26 also summarizes RQs for exposure scenarios that characterize specific COUs; Sections 4.1.3.1.3 and 4.1.3.2.3 characterize the screening approach used to characterize risk for the COU of Recycling of electronics waste containing HIPS that contain HBCD. Exposure scenario-specific risk for aquatic organisms is summarized above in Section 4.1.3.1.2, in Table 4-5, where both 10th (high-end) and 50th percentile (central tendency) surface water and sediment concentrations are used to calculate risk. Additionally, the environmental hazard endpoints used to derive COCs are summarized above in Section 4.1.2, in Table 4-1. For characterizing risk to pelagic organisms, either 1- or 21-d average surface water concentrations of HBCD were used. Specifically, the 1-d average surface water concentrations were compared to both the acute fish (0.4 µg/L) and algae (1 µg/L) COCs, and the 21-d average surface water concentrations were compared to the chronic water flea COC (0.42 µg/L). For characterizing risk to benthic organisms, the 28-d average sediment concentration was compared to the 28-d blackworm chronic COC (1,570 µg/kg). The below discussion will focus on exposure scenarios where there is at least one exposure sub-scenario with a RQ ≥ 1 (denoting when media exposure concentrations exceeds the hazard threshold), using either the 10th or 50th percentile predicted surface water or sediment HBCD concentrations.

As explained above in Section 4.1.4.1, for the exposure scenario of land disposal of other formulated products and articles (*e.g.*, adhesives, coatings, textiles, and electronics), environmental monitoring data

was used exclusively as the proxy for characterizing risk to aquatic organisms (whereas modeled surface water and sediment HBCD concentrations were used to characterize risk to aquatic organisms for the other exposure scenarios with surface water releases).

Pelagic Organism Risk based on Predicted Surface Water Concentrations of HBCD

All exposure scenarios have at least one $RQ \geq 1$ using the acute, algae or chronic COC, based on predicted HBCD surface water releases. The below listed exposure scenarios are categorized by the whether or not there is at least one $RQ \geq 1$ based on the acute, algae and/or chronic COCs.

For the following exposure scenarios, there are risks for pelagic organisms relative to the acute, algae and chronic COCs. All of the below listed exposure scenarios have $RQs \geq 1$ for at least half of the exposure sub-scenarios for both the acute and algae COCs. The single asterisk depicts whether at least half of the exposure sub-scenarios have $RQs \geq 1$ relative to all three COCs. The double asterisk depicts when the RQs are ≥ 1 based on measured monitoring data near industrial facilities (background information).

- Repackaging of Import Containers (1)*
- Compounding of Polystyrene Resin to Produce XPS Masterbatch (2)
- Processing of HBCD to produce XPS Foam using XPS Masterbatch (3)
- Processing of HBCD to produce XPS Foam using HBCD Powder (4)
- Processing of HBCD to produce EPS Foam from Imported EPS Resin Beads (5)*
- Processing of HBCD to produce SIPs and Automobile Replacement Parts from XPS/EPS Foam (6)
- Demolition and Disposal of XPS/EPS Foam Insulation Products in Residential, Public and Commercial Buildings, and Other Structures (9)
- Recycling of EPS Foam and Reuse of XPS Foam (10)
- Land disposal of other formulated products and articles (*e.g.*, adhesives, coatings, textiles, and electronics)**

For the following exposure scenario, there are risks for pelagic organisms relative to the acute and algae COCs. The asterisk depicts whether at least half of the exposure sub-scenarios have $RQs \geq 1$ relative to both COCs.

- Installation of XPS/EPS Foam Insulation in Residential, Public, and Commercial Buildings, and Other Structures (8)*

For the following exposure scenario, there is risk for pelagic organisms relative to the acute COC.

- Use of Flux/Solder Pastes (12)

For the following exposure scenario, it is unlikely that there is risk for pelagic organisms relative to any of the COCs.

- Recycling of electronics waste containing HIPs (13)

Benthic Organism Risk based on Predicted Sediment Concentrations of HBCD

Most of the exposure scenarios have at least one $RQ \geq 1$ using the chronic COC, based on predicted HBCD sediment HBCD concentrations using either the 11- or 128-d HBCD half-life. The below listed exposure scenarios are categorized by the whether or not there is at least one $RQ \geq 1$ based on the chronic COC.

For the following exposure scenarios, there are risks for benthic organisms relative to the chronic COC, using both the 11- and 128-d HBCD half-life. The single asterisk depicts whether at least half of the exposure sub-scenarios have $RQs \geq 1$ relative to the chronic COC, using both HBCD half-lives. The

double asterisk depicts when the RQs are ≥ 1 based on measured monitoring data near industrial facilities (background information).

- Repackaging of Import Containers (1)*
- Processing of HBCD to produce XPS Foam using XPS Masterbatch (3)
- Processing of HBCD to produce EPS Foam from Imported EPS Resin Beads (5)*
- Processing of HBCD to produce SIPs and Automobile Replacement Parts from XPS/EPS Foam (6)
- Recycling of EPS Foam and Reuse of XPS Foam (10)
- Land disposal of other formulated products and articles (*e.g.*, adhesives, coatings, textiles, and electronics)**

For the following exposure scenarios, there are risks for benthic organisms relative to the chronic COC, using both 128-d HBCD half-life. The asterisk depicts whether at least half of the exposure sub-scenarios have RQs ≥ 1 relative to the chronic COC.

- Compounding of Polystyrene Resin to Produce XPS Masterbatch (2)
- Processing of HBCD to produce XPS Foam using HBCD Powder (4)
- Installation of XPS/EPS Foam Insulation in Residential, Public, and Commercial Buildings, and Other Structures (8)*

For the following exposure scenario, it is unlikely that there is risk for benthic organisms relative to the chronic COC, using either HBCD half-lives.

- Demolition and Disposal of XPS/EPS Foam Insulation Products in Residential, Public and Commercial Buildings, and Other Structures (9)
- Use of Flux/Solder Pastes (12)
- Recycling of electronics waste containing HIPs (13)

As summarized below in Table 4-26, the bolded and shaded in gray text indicate when at least half of the modeled exposure subscenarios have RQ ≥ 1 .

4.5.1.2 Summary of Risk Estimates for Terrestrial Organisms

Risk estimates for terrestrial organisms based on environmental monitoring data (near industrial facilities and general population sites, as categorized by study authors) are summarized for terrestrial above in Section 4.1.4.2. The average of 90th percentile (high-end) and mean of means (central tendency) soil concentrations summarized in Table 4-6 are used to calculate risk for soil organisms that inhabit ecosystems near industrial facilities (point source) or general population (non-point source) sites. Specifically, the high-end and central tendency soil concentrations measured near industrial facilities or general population sites were compared to the chronic earthworm COC (173,000 $\mu\text{g}/\text{kg}$). RQs are less than one based on environmental monitoring data attained near both industrial facilities and general population sites, and are therefore not presented below in Table 4-26.

Similarly, as presented in Appendix Table_Apx J-13, all RQs are < 1 when using the highest IIOAC predictions for soil HBCD concentrations, based on exposure scenario-specific releases, in either the fence line or community scenarios. Section 4.1.3.2.3 also describes the screening approach used to characterize risk to soil organisms for the COU of Recycling of electronics waste containing HIPs that contain HBCD. The results suggest that it is unlikely that any of the exposure scenarios alone will result in soil concentrations of HBCD that will surpass the chronic COC. Due to there being an unlikelihood of risk to soil organisms due to chronic HBCD from air deposition, these results are not provided below in Table 4-26.

Table 4-26. Summary of Risk for Aquatic Organisms

Life Cycle Stage	Category ^a	Subcategory ^b	Exposure Scenario ^c	Population ^d	Exposure Route	Hazard Threshold	Risk Estimates ^e	
							High-End	Central Tendency
Manufacture	Import	Import	Section 2.4.1.2 – Repackaging of Import Containers (1)	Aquatic Organisms	Surface Water	Acute (COC= 0.4µg HBCD/L)	4.3-189	0.09-24.2
						Algae (COC= 1 µg HBCD/L)	1.72-75.6	0.04-0.83
						Chronic (COC= 0.417µg HBCD/L)	3.5-21.22	0.07-2.26
					Sediment	11-d Half-Life (COC: 1,570 µg/kg)	0.88-4.61	0.02-0.56
						128-d Half-Life (COC: 1,570 µg/kg)	2.29-11.91	0.05-1.26
Processing	Processing-Incorporated into formulation, mixture or reaction product	Flame retardants used in custom compounding of resin (<i>e.g.</i> , compounding in XPS masterbatch) and in solder paste	Section 2.4.1.3 – Compounding of Polystyrene Resin to Produce XPS Masterbatch (2)	Aquatic Organisms	Surface Water	Acute (COC= 0.4µg HBCD/L)	3.48-34.75	0.09-2.08
						Algae (COC= 1 µg HBCD/L)	1.39-31.3	0.04-0.83
						Chronic (COC= 0.417µg HBCD/L)	0.19-4.22	0-0.1
					Sediment	11-d Half-Life (COC: 1,570 µg/kg)	0.03-0.77	0-0.02
						128-d Half-Life (COC: 1,570 µg/kg)	0.08-1.86	0-0.04
	Incorporated into articles	Flame retardants used in plastics product manufacturing (manufacture of	Section 2.4.1.4 – Processing of HBCD to produce XPS Foam using XPS Masterbatch	Aquatic Organisms	Surface Water	Acute (COC= 0.4µg HBCD/L)	0.76-275	0.02-7.33
						Algae (COC= 1 µg HBCD/L)	0.3-110	0.01-2.93

Life Cycle Stage	Category ^a	Subcategory ^b	Exposure Scenario ^c	Population ^d	Exposure Route	Hazard Threshold	Risk Estimates ^e	
							High-End	Central Tendency
		XPS and EPS foam; manufacture of structural insulated panels (SIPS) and automobile replacement parts from XPS and EPS foam)	(3)		Sediment	Chronic (COC= 0.417µg HBCD/L)	0.04-13.55	0-0.34
						11-d Half-Life (COC: 1,570 µg/kg)	0.01-2.22	0-0.06
						128-d Half-Life (COC: 1,570 µg/kg)	0.03-2.97	0-0.08
			Section 2.4.1.5 – Processing of HBCD to produce XPS Foam using HBCD Powder (4)	Aquatic Organisms	Surface Water	Acute (COC= 0.4µg HBCD/L)	0.91-107	0.02-2.85
						Algae (COC= 1 µg HBCD/L)	0.36-42.8	0.01-1.14
						Chronic (COC= 0.417µg HBCD/L)	0.05-5.25	0-0.13
					Sediment	11-d Half-Life (COC: 1,570 µg/kg)	0.01-0.87	0-0.02
						128-d Half-Life (COC: 1,570 µg/kg)	0.02-1.16	0-0.03
			Section 2.4.1.6 – Processing of HBCD to produce EPS Foam from Imported EPS Resin Beads (5)	Aquatic Organisms	Surface Water	Acute (COC= 0.4µg HBCD/L)	89.5-9,900	2.2-262.5
		Algae (COC= 1 µg HBCD/L)				35.8-3,960	0.88-105	
		Chronic (COC= 0.417µg HBCD/L)				33.57-563.55	0.71-12.01	
		Sediment			11-d Half-Life (COC: 1,570 µg/kg)	8.73-143.31	0.21-3.52	
					128-d Half-Life (COC: 1,570 µg/kg)	22.68-361.78	0.48-7.77	
		Section 2.4.1.7– Processing of	Aquatic Organisms	Surface Water	Acute (COC= 0.4µg HBCD/L)	0.97-148.75	0.02-3.93	

Life Cycle Stage	Category ^a	Subcategory ^b	Exposure Scenario ^c	Population ^d	Exposure Route	Hazard Threshold	Risk Estimates ^e						
							High-End	Central Tendency					
			HBCD to produce SIPs and Automobile Replacement Parts from XPS/EPS Foam (6)			Algae (COC= 1 µg HBCD/L)	0.39-59.5	0.01-1.57					
						Chronic (COC= 0.417µg HBCD/L)	0.19-8.47	0-0.18					
						Sediment	11-d Half-Life (COC: 1,570 µg/kg)	0.05-2.15	0-0.05				
							128-d Half-Life (COC: 1,570 µg/kg)	0.12-5.44	0-0.12				
						Recycling	Recycling of XPS and EPS foam, resin, panels containing HBCD; Recycling of electronics waste containing HIPS that contain HBCD	Section 2.4.1.11 – Recycling of EPS Foam and Reuse of XPS Foam (10)	Aquatic Organisms	Surface Water	Acute (COC= 0.4µg HBCD/L)	1.2-183.25	0.03-4.88
											Algae (COC= 1 µg HBCD/L)	0.48-73.3	0.01-1.95
	Chronic (COC= 0.417µg HBCD/L)	0.45-9.02	0.01-0.22										
	Sediment	11-d Half-Life (COC: 1,570 µg/kg)	0.12-1.48	0-0.04									
		128-d Half-Life (COC: 1,570 µg/kg)	0.17-1.98	0-0.06									
			Section 2.4.1.14– Recycling of electronics waste containing HIPS (13)	Aquatic Organisms	As discussed in Section 4.1.3.1.3, HBCD is not expected to be released into surface water from this exposure scenario, therefore it is unlikely that there will be risk to aquatic organisms (both pelagic and benthic).								
Distribution	Distribution	Distribution	Activities related to distribution (<i>e.g.</i> , loading, unloading) are considered throughout the life cycle, rather than using a single distribution scenario.										
Commercial /Consumer Use	Building/ construction materials	Plastic articles (hard: construction and building materials covering large surface areas (<i>e.g.</i> , XPS/EPS foam insulation in residential, public and commercial buildings, and other structures) and solder paste	Section 2.4.1.9 – Installation of XPS/EPS Foam Insulation in Residential, Public, and Commercial Buildings, and Other Structures (8)	Aquatic Organisms	Surface Water	Acute (COC= 0.4µg HBCD/L)	0.05-59.25	0.01-8.45					
						Algae (COC= 1 µg HBCD/L)	0.02-23.7	0-3.38					
						Chronic (COC= 0.417µg HBCD/L)	0-0.41	0-0.04					
					Sediment	11-d Half-Life (COC: 1,570 µg/kg)	0.06-0.57	0.01-0.07					
						128-d Half-Life (COC: 1,570 µg/kg)	0.13-1.28	0.01-0.1					

Life Cycle Stage	Category ^a	Subcategory ^b	Exposure Scenario ^c	Population ^d	Exposure Route	Hazard Threshold	Risk Estimates ^e	
							High-End	Central Tendency
Disposal	Disposal	Land disposal of construction and demolition waste	Section 2.4.1.13 – Use of Flux/Solder Pastes (12)	Aquatic Organisms	Surface Water	Acute (COC= 0.4µg HBCD/L)	0.58-1.19	0.02-0.15
						Algae (COC= 1 µg HBCD/L)	0.23-0.47	0.01-0.06
						Chronic (COC= 0.417µg HBCD/L)	0.03-0.06	0-0.01
					Sediment	11-d Half-Life (COC: 1,570 µg/kg)	0-0.01	0
						128-d Half-Life (COC: 1,570 µg/kg)	0.01-0.02	0
		Land disposal of formulated products (e.g., adhesives, and coatings) and articles (e.g. textiles, electrical and electronic products)	Section 2.4.1.10 – Demolition and disposal of XPS/EPS Foam Insulation Products in Residential, Public and Commercial Buildings, and Other Structures (9)	Aquatic Organisms	Surface Water	Acute (COC= 0.4µg HBCD/L)	0.05-59.25	0.01-8.45
						Algae (COC= 1 µg HBCD/L)	0.02-23.7	0-3.38
						Chronic (COC= 0.417µg HBCD/L)	0-4.10	0-0.04
					Sediment	11-d Half-Life (COC: 1,570 µg/kg)	0.01-0.1	0.002-0.02
						128-d Half-Life (COC: 1,570 µg/kg)	0.001-0.01	0.0001-0.0007
Land disposal of formulated products (e.g., adhesives, and coatings) and articles (e.g. textiles, electrical and electronic products)	Near Industrial Facilities (Point Source Background Exposure) ^f	Aquatic Organisms	Surface Water	Acute (COC= 0.4µg HBCD/L)	2.48	2.10		
				Algae (COC= 1 µg HBCD/L)	0.99	0.84		
				Chronic (COC= 0.417µg HBCD/L)	2.38	2.02		
	Sediment		Chronic (COC: 1,570 µg/kg)	3.23	2.19			
	Near General Population (Non-Point Source)		Surface Water	Acute (COC= 0.4µg HBCD/L)	2.00E-03	1.03E-03		
				Algae (COC= 1 µg HBCD/L)	8.00E-04	4.10E-04		

Life Cycle Stage	Category ^a	Subcategory ^b	Exposure Scenario ^c	Population ^d	Exposure Route	Hazard Threshold	Risk Estimates ^e	
							High-End	Central Tendency
			Background Exposure) ^f			Chronic (COC= 0.417µg HBCD/L)	1.92E-03	9.83E-04
					Sediment	Chronic (COC: 1,570 µg/kg)	0.01	0.004

^a These categories of conditions of use appear in the Life Cycle Diagram, reflect CDR codes, and broadly represent conditions of use of HBCD in industrial and/or commercial settings.

^b These subcategories reflect more specific uses of HBCD.

^c Exposure scenarios are numbered in parentheses. This numbering will be referred to throughout the document, including for exposure subscenarios (*e.g.*, 3.1, 3.2, etc). Only exposure scenarios with water releases are presented in this table.

^d For terrestrial soil organisms, all soil concentrations attained either through measured background concentrations, or modeled for specific air releases attributed to an exposure scenario are all less than one, and therefore risk is unlikely for terrestrial soil organisms.

^e Risk quotient ranges are bolded if there is at least one risk quotient (RQ) are equal to or greater than one (exposure exceeds the hazard threshold). Risk quotients bolded and highlighted in gray demonstrate when at least half of the RQs for an exposure scenario are equal to or greater than one (exposure exceeds the hazard threshold).

Risk based on modeled information attributed to a release from a specific exposure scenario: For aquatic organisms, exposure scenario-specific risk estimates based on high-end and central tendency predictions for surface water and sediment concentrations are based on 10th and 50th percentile flow rates, respectively. For terrestrial organisms, exposure scenario-specific risk estimates for fence line and community sites did not result in risk estimates equal to or greater than one and are provided in Appendix J.1.3.1.

Risk based on measured background information that is not attributed to a release from a specific exposure scenario: For aquatic and terrestrial background exposure where risk estimates are based on monitoring data, high-end and central tendency predictions for aquatic (*i.e.*, surface water and sediment concentrations) and terrestrial (*i.e.*, soil) organisms are based on an average of 90th percentile and mean of mean measured environmental media concentrations, respectively. Terrestrial organism risk resulting from background exposure is described in Section 4.1.3.2.3.

^f Background information is used as a proxy to characterize the risk from the COU of Disposal of other formulated products and articles (*e.g.*, adhesives, coatings, textiles, and electronics) because water and air releases are predicted to occur, but in lieu of not having media-specific release information for this COU.

4.5.2 Human Health Risk Conclusions

A summary of risk estimates is provided below for workers, the general population, and consumers. Risk estimates presented in tables represent the most robust and sensitive values when accounting for all of the assessed lifestages and PESS groups.

4.5.2.1 Summary of Risk Estimates for Workers

Table 4-27 summarizes the risk estimates for inhalation and dermal exposures for all occupational exposure scenarios. Risk estimates that exceed the benchmark (*i.e.*, MOEs less than the benchmark MOE) are highlighted by bolding the number and shading the cell in gray. The occupational exposure assessment and risk characterization are described in more detail in Sections 2.4.1 and 4.2.2, respectively. Occupational non-users (ONUs) are expected to have lower exposure levels than workers in most instances but exposures could not be quantified. Based on the particulate form of HBCD with low volatility, ONUs are not expected to be exposed at comparable levels to workers (an exception is for installation and demolition of XPS/EPS in insulation, see Section 4.3.2.3). Specific links to the relevant exposure sections in the document are listed in Table 4-27 in the Occupational Exposure Scenario column.

The risk summary below is based on the most sensitive and robust acute (offspring loss) and chronic (thyroid hormone effects) endpoints. Thyroid hormone changes (both acute and chronic) are considered the primary effect resulting from HBCD exposure, as they lead to all of the other observed downstream endpoints. When risk conclusions differ for average workers and women of childbearing age, Table 4-27 presents the risk estimate for the more sensitive subpopulation of women of childbearing age.

Inhalation Exposure

For acute and chronic exposure scenarios via inhalation without PPE (*i.e.*, no respirators) there are risks for workers relative to the benchmarks for the following occupational exposure scenarios at both the high-end and central tendency exposure level from acute and/or chronic exposure durations.

- Repackaging of import containers
- Compounding of polystyrene resin to produce XPS Masterbatch
- Formulation of flux/solder pastes
- Processing of HBCD to produce XPS foam using HBCD powder

For the following exposure scenarios, there are risks for workers relative to the benchmarks only at high-end exposure level from acute and/or chronic exposure durations:

- Processing of HBCD to produce EPS Foam from imported EPS resin beads
- Processing of HBCD to produce SIPs and automobile replacement parts from XPS/EPS foam
- Recycling of EPS foam and reuse of XPS foam
- Installation of XPS/EPS foam insulation in residential, public, and commercial buildings, and other structures
- Use of flux/solder pastes
- Demolition and Disposal of XPS/EPS foam insulation products in residential, public and commercial buildings, and other structures

When respirators are worn (APF 5, 10, or 50), risks are mitigated to below the benchmarks for both acute and chronic exposure durations at both exposure levels. Workers exposed through installation or demolition of XPS/EPS foam in insulation are unlikely to wear respiratory protection. Therefore, when considering assumed PPE usage, risk remains only for the following exposure scenarios:

- Installation of XPS/EPS foam insulation in residential, public, and commercial buildings, and other structures
- Demolition and Disposal of XPS/EPS foam insulation products in residential, public and commercial buildings, and other structures

The following exposure scenarios did not have risk for either acute (when applicable) or chronic exposure scenarios at any exposure level:

- Processing of HBCD to produce XPS foam using XPS Masterbatch
- Occupational microenvironments
- Recycling of electronics waste containing HIPS

Dermal Exposure

For acute and chronic exposures via dermal contact without PPE (*i.e.*, no gloves) there are risks for workers relative to the benchmark for the following exposure scenarios at both high and central tendency exposure levels:

- Repackaging of import containers
- Compounding of polystyrene resin to produce XPS Masterbatch
- Formulation of flux/solder pastes
- Processing of HBCD to produce XPS foam using XPS Masterbatch
- Processing of HBCD to produce XPS foam using HBCD powder

For the following exposure scenario, there are risks for workers relative to the benchmark following chronic exposure at the high-end exposure level:

- Use of flux/solder paste

EPA does not expect any level of dermal exposure to HBCD following proper use of impervious gloves. Therefore, risk estimates are not provided and risks are not identified for any exposure scenario when impervious gloves are assumed to be worn and used appropriately.

Table 4-27. Occupational Risk Summary Table

Life Cycle Stage/Category	Subcategory	Occupational Exposure Scenario (#)	Population	Exposure Route	Sub-Scenario Exposure Level	Risk Estimates for No PPE		Risk Estimates with PPE	
						Acute Non-Cancer (benchmark MOE = 100)	Chronic Non-Cancer (benchmark MOE = 300)	Acute Non-Cancer (benchmark MOE = 100)	Chronic Non-Cancer (benchmark MOE = 300)
Manufacture - Import	Import	Section 2.4.1.2 – Repackaging of Import Containers (1)	Workers	Inhalation	High-End	38	10	191 (APF 5)	519 (APF 50)
					Central Tendency	81	39	406 (APF 5)	394 (APF 10)
				Dermal	High-End	4	1	Exposure not expected with impervious gloves	
					Central Tendency	12	2		
Processing - Incorporated into formulation, mixture or reaction product	Flame retardants used in custom compounding of resin (e.g., compounding in XPS masterbatch) and in solder paste	Section 2.4.1.3 – Compounding of Polystyrene Resin to Produce XPS Masterbatch (2)	Workers	Inhalation	High-End	29	33	144 (APF 5)	1635 (APF 50)
					Central Tendency	58	112	289 (APF 5)	560 (APF 5)
				Dermal	High-End	4	4	Exposure not expected with impervious gloves	
					Central Tendency	12	7		
	Section 2.4.1.12 – Formulation of Flux/Solder Pastes (11)	Workers	Inhalation	High-End	29	8	144 (APF 5)	392 (APF 50)	
				Central Tendency	58	31	289 (APF 5)	1533 (APF 50)	
			Dermal	High-End	4	1	Exposure not expected with impervious gloves		
				Central Tendency	12	2			
Processing - Incorporated into articles	Flame retardants used in plastics product manufacturing (manufacture of XPS and EPS foam;	Section 2.4.1.4 – Processing of HBCD to produce XPS Foam using XPS Masterbatch (3)	Workers	Inhalation	High-End	328	1394	1642 (APF 5)	6970 (APF 5)
					Central Tendency	903	6813	4515 (APF 5)	34065 (APF 5)
				Dermal	High-End	5	22	Exposure not expected with impervious gloves	
					Central Tendency	18	39		

Life Cycle Stage/Category	Subcategory	Occupational Exposure Scenario (#)	Population	Exposure Route	Sub-Scenario Exposure Level	Risk Estimates for No PPE		Risk Estimates with PPE	
						Acute Non-Cancer (benchmark MOE = 100)	Chronic Non-Cancer (benchmark MOE = 300)	Acute Non-Cancer (benchmark MOE = 100)	Chronic Non-Cancer (benchmark MOE = 300)
	manufacture of structural insulated panels (SIPS) and automobile replacement parts from XPS and EPS foam)	Section 2.2.5 – Processing of HBCD to produce XPS Foam using HBCD Powder (4)	Workers	Inhalation	High-End	29	123	144 (APF 5)	615 (APF 5)
					Central Tendency	58	436	289 (APF 5)	2180 (APF 5)
				Dermal	High-End	4	15	Exposure not expected with impervious gloves	
					Central Tendency	12	27		
		Section 2.4.1.6 – Processing of HBCD to produce EPS Foam from Imported EPS Resin Beads (5)	Workers	Inhalation	High-End	328	159	1642 (APF 5)	795 (APF 5)
					Central Tendency	903	786	4515 (APF 5)	3930 (APF 5)
Section 2.4.1.7 – Processing of HBCD to produce SIPs and Automobile Replacement Parts from XPS/EPS Foam (6)	Workers	Inhalation	High-End	328	89	1642 (APF 5)	445 (APF 5)		
			Central Tendency	903	461	4515 (APF 5)	2305 (APF 5)		
Processing - Recycling	Recycling of XPS and EPS foam, resin, panels containing HBCD	Section 2.4.1.11 – Recycling of EPS Foam and Reuse of XPS Foam (10)	Workers	Inhalation	High-End	328	159	1642 (APF 5)	795 (APF 5)
					Central Tendency	903	864	4515 (APF 5)	4320 (APF 5)
	Recycling of electronics waste containing HIPS that contain HBCD	Section 2.4.1.14 – Recycling of electronics waste containing HIPS	Workers	Inhalation	High-End	722400	196224	Not calculated	Not calculated
					Central Tendency	5197122	2778904		
Distribution - Distribution	Distribution	Activities related to distribution (e.g., loading, unloading) are considered throughout the life cycle, rather than using a single distribution scenario							
Commercial/consumer use -Building/construction materials	Plastic articles (hard: construction and building materials covering large surface areas (e.g., XPS/EPS foam insulation in	Section 2.4.1.9 – Installation of XPS/EPS Foam Insulation in Residential, Public, and Commercial Buildings, and Other Structures (8) ^b	Workers	Inhalation	High-End	328	89	1642 ^a (APF 5)	445 ^a (APF 5)
					Central Tendency	903	487	4515 ^a (APF 5)	2435 ^a (APF 5)

Life Cycle Stage/Category	Subcategory	Occupational Exposure Scenario (#)	Population	Exposure Route	Sub-Scenario Exposure Level	Risk Estimates for No PPE		Risk Estimates with PPE	
						Acute Non-Cancer (benchmark MOE = 100)	Chronic Non-Cancer (benchmark MOE = 300)	Acute Non-Cancer (benchmark MOE = 100)	Chronic Non-Cancer (benchmark MOE = 300)
	residential, public and commercial buildings, and other structures) and solder paste	Section 2.4.1.13 – Use of Flux/Solder Pastes (12)	Workers	Dermal	High-End	1010	274	Exposure not expected with impervious gloves	
					Central Tendency	2470	540		
Commercial/consumer use - Other	Formulated products (e.g., adhesives and coatings) and articles (e.g., textiles, electrical and electronic products)	Section 2.4.2.2.6 – Occupational Microenvironments	Workers	Multiple	High-End	N/A ^c	>320,000	Not calculated	Not calculated
Disposal - Disposal	Land disposal of construction and demolition waste	Section 2.4.1.10 – Demolition and Disposal of XPS/EPS Foam Insulation Products in Residential, Public and Commercial Buildings, and Other Structures (9) ^b	Workers	Inhalation	High-End	241	65	1204 ^a (APF 5)	654 ^a (APF 10)
					Central Tendency	688	371	3440 ^a (APF 5)	1855 (APF 5)
	Land disposal of formulated products (e.g., adhesives and coatings) and articles (e.g., textiles, electrical and electronic products)	Section 2.4.2.2.6 – Occupational Microenvironments	Workers	Multiple	High-End	N/A ^c	>320,000	Not calculated	Not calculated

^a EPA is presenting MOEs for respiratory PPE as a what-if scenario, however EPA believes that workers in these OES are unlikely to wear respirators.

^b ONUs may be exposed to HBCD air concentrations similarly to workers in this OES.

^c Background general population exposures are only relevant to chronic hazards.

4.5.2.2 Summary of Risk Estimates for General Population and Consumers

Based on qualitative consideration of the physical-chemical and fate characteristics as well as low concentrations in surface water and the absence of any monitored levels in drinking water, HBCD is not expected to be present in drinking water. Therefore, risks were not identified for HBCD via drinking water exposure.

Based on qualitative consideration of the low potential for HBCD sent to landfills (*e.g.*, construction and demolition landfills), HBCD is not expected to migrate through the landfill to groundwater and reach receptors via groundwater ingestion or groundwater entering surface water. HBCD is a solid and likely to be entrained in a solid matrix (XPS/EPS foam) when disposed of in a landfill. HBCD's high soil organic carbon partition coefficient (>100,000) and low water solubility (66 µg/L) indicates it will preferentially partition to soil organic carbon and exhibit very slow movement through soil to groundwater. Therefore, risks were not identified for general population from HBCD via landfill leachate.

Table 4-28 summarizes the risk estimates for inhalation and dermal exposures for the highly exposed general population (including consumers). Risk estimates that exceed the benchmark (*i.e.*, MOEs less than the benchmark MOE) are highlighted by bolding the number and shading the cell in gray. The highly exposed general population exposure assessment and risk characterization are described in more detail in Sections 2.4.3 and 4.2.2, respectively. Details on the exposure assessment for each highly exposed general population scenario can be found in Section 2.4.3, and consumer scenarios are described in Section 2.4.4.

The risk summary below is based on the most sensitive and robust acute (offspring loss) and chronic (thyroid hormone effects) endpoints. Thyroid hormone changes (both acute and chronic) are considered the primary effect resulting from HBCD exposure, as they are associated with all of the other observed downstream endpoints.

Table 4-28. Highly Exposed General Population/Consumer Risk Summary Table

Life Cycle Stage/ Category	Subcategory	Exposure Scenario (#)	Population	Exposure Route	Sub-Scenario Exposure Level	Risk Estimates		
						Acute Non-Cancer (benchmark MOE = 100)	Chronic Non-Cancer (benchmark MOE = 300)	
Manufacture - Import	Import	Repackaging of Import Containers (1)	General Population (Highly Exposed)	Air Inhalation	Moderate	37630	>16800	
					Highest	1307		
				Fish Ingestion	Moderate	1678	13493	
					Highest	338	3314	
Processing - Incorporated into formulation, mixture or reaction product	Flame retardants used in custom compounding of resin (e.g., compounding in XPS masterbatch) and in solder paste	Compounding of Polystyrene Resin to Produce XPS Masterbatch (2)	General Population (Highly Exposed)	Air Inhalation	Moderate	209835	>16800	
					Highest	128508		
				Fish Ingestion	Moderate	15033	42626	
					Highest	1763	32594	
		Formulation of Flux/Solder Pastes (11)	General Population (Highly Exposed)	Air Inhalation	Moderate	119229	>16800	
					Highest	39092		
Processing - Incorporated into articles	Flame retardants used in plastics product manufacturing (manufacture of XPS and EPS foam; manufacture of structural insulated panels (SIPS) and automobile replacement parts from XPS and EPS foam)	Processing of HBCD to produce XPS Foam using XPS Masterbatch (3)	General Population (Highly Exposed)	Air Inhalation	Moderate	20056	>16800	
					Highest	2743		
				Fish Ingestion	Moderate	7187	48741	
					Highest	509	15499	
				Air Inhalation	General Population (Highly Exposed)	Moderate	39449	>16800
						Highest	2622	
		Fish Ingestion	Moderate	14541	52951			
			Highest	1308	27971			
		Processing of HBCD to produce EPS Foam from Imported EPS Resin Beads (5)	General Population (Highly Exposed)	Air Inhalation	Moderate	4705	>16800	
					Highest	680		
				Fish Ingestion	Moderate	139	5376	
					Highest	14	587	
		Processing of HBCD to produce SIPS and Automobile Replacement Parts from XPS/EPS Foam (6)	General Population (Highly Exposed)	Air Inhalation	Moderate	154878	>16800	
					Highest	14212		
Fish Ingestion	Moderate			4234	43862			
	Highest			922	23422			
Processing - Recycling	Recycling of XPS and EPS foam, resin, panels containing HBCD	Recycling of EPS Foam and Reuse of XPS Foam (10)	General Population (Highly Exposed)	Air Inhalation	Moderate	140770	>16800	
					Highest	38255		
				Fish Ingestion	Moderate	7939	34063	
					Highest	764	20463	

Life Cycle Stage/ Category	Subcategory	Exposure Scenario (#)	Population	Exposure Route	Sub-Scenario Exposure Level	Risk Estimates		
						Acute Non-Cancer (benchmark MOE = 100)	Chronic Non-Cancer (benchmark MOE = 300)	
	Recycling of electronics waste containing HIPS that contain HBCD	Recycling of electronics waste containing HIPS (13)	General Population (Highly Exposed)	Air Inhalation	Relative Risk ^b	>680	>16800	
Distribution - Distribution	Distribution	Activities related to distribution (<i>e.g.</i> , loading, unloading) are considered throughout the life cycle, rather than using a single distribution scenario						
Commercial/ consumer use - Building/ construction materials	Plastic articles (hard: construction and building materials covering large surface areas (<i>e.g.</i> , XPS/EPS foam insulation in residential, public and commercial buildings, and other structures) and solder paste	Installation of XPS/EPS Foam Insulation in Residential, Public, and Commercial Buildings, and Other Structures (8)	General Population (Highly Exposed)	Air Inhalation	Moderate	77282	>16800	
				Air Inhalation	Highest	62609		
			Consumers	Fish Ingestion	Moderate	16081	46588	
				Fish Ingestion	Highest	1687	17074	
		Use of Flux/Solder Pastes (12)	General Population (Highly Exposed)	General Population (Highly Exposed)	Dust/Indoor air	Single Scenario	35411	22722
					Air Inhalation	Moderate	222576	>16800
			Air Inhalation	Highest	221704			
			Fish Ingestion	Moderate	127338	56195		
Fish Ingestion	Highest	80233	54800					
Commercial/ consumer use - Other	Automobile replacement parts	Installation of Automobile Replacement Parts (7)	Consumers	Dust/indoor air	Single Scenario	11259	52020	
	Plastic and other articles	Mouthing of articles containing HBCD	Consumers	Mouthing	Single Scenario	944	2713	
	Formulated products (<i>e.g.</i> , adhesives and coatings) and articles (<i>e.g.</i> , textiles, electrical and electronic products)	General Population Background Exposure	General Population	Multiple	Central Tendency	N/A ^c	>42129	
High-End					N/A ^c	>9959		
Disposal - Disposal	Other land disposal (<i>e.g.</i> , construction and demolition waste)	Demolition and Disposal of XPS/EPS Foam Insulation Products in Residential, Public and Commercial Buildings, and Other Structures (9)	General Population (Highly Exposed)	Air Inhalation	Moderate	224448	>16800	
					Air Inhalation	Highest		10310
				Fish Ingestion	Moderate	2520	22163	
					Fish Ingestion	Highest	254	3388

^a Background general population exposures are only relevant to chronic hazards.

^b Exposure estimates were not formally calculated for this COU. Risk was estimated by comparing releases and potential MOEs relative to worst-case sub-scenarios.

^c Background general population exposures are only relevant to chronic hazards.

EPA also estimated risks to additional PESS groups based on aggregate exposures that could not be directly tied to a particular exposure scenario or COU. Instead, risk estimates are based on aggregated ambient or background exposure via all exposure routes and therefore only risks resulting from chronic exposures were estimated. Table 4-29 presents a summary of risk estimates for these groups based on the most sensitive endpoint of thyroid hormone effects. Risks were not identified for any of these PESS groups even based on the most sensitive endpoint and exposure estimates.

Table 4-29. Risk Summary for Additional PESS Groups

Receptor	Chronic MOE (benchmark MOE = 300)	Section Reference
<p style="text-align: center;">Infants (<1 year old) (Maximum Estimated Dose, assumed 90%tile as high-end of monitoring data)</p>	468	Section 4.2.3.3.2
<p style="text-align: center;">Subsistence Fishers (Near-Field, High-End [95%tile])</p>	2215	Table 4-20

5 UNREASONABLE RISK DETERMINATION

5.1 Overview

In each Risk Evaluation under TSCA section 6(b), EPA determines whether a chemical substance presents an unreasonable risk of injury to health or the environment, under the conditions of use. These determinations do not consider costs or other non-risk factors. In making these determinations, EPA considers relevant risk-related factors, including, but not limited to: the effects of the chemical substance on health and human exposure to such substance under the conditions of use (including cancer and non-cancer risks); the effects of the chemical substance on the environment and environmental exposure under the conditions of use; the population exposed (including any potentially exposed or susceptible subpopulations (PESS)); the severity of hazard (including the nature of the hazard, the irreversibility of the hazard); and uncertainties. EPA also takes into consideration the Agency's confidence in the data used in the risk estimate. This includes an evaluation of the strengths, limitations, and uncertainties associated with the information used to inform the risk estimates and the risk characterization. This approach is in keeping with the Agency's final rule, *Procedures for Chemical Risk Evaluation Under the Amended Toxic Substances Control Act* ([82 FR 33726](#)).²¹

This section describes the final unreasonable risk determinations for the conditions of use in the scope of the Risk Evaluation for the cyclic aliphatic bromide cluster chemicals. EPA evaluated two of the three chemicals in the cluster: CASRN 25637-99-4 and CASRN 3194-55-6. In this final Risk Evaluation document, the use of "HBCD" refers to either or both chemicals. No conditions of use were identified for the third chemical, CASRN 3194-57-8. The final unreasonable risk determinations are based on the risk estimates in the final Risk Evaluation, which may differ from the risk estimates in the draft Risk Evaluation due to peer review and public comments. Therefore, the final unreasonable risk determinations of some conditions of use may differ from those in the draft Risk Evaluation.

5.1.1 Human Health

EPA's Risk Evaluation identified non-cancer adverse effects from acute and chronic exposures to HBCD. The health risk estimates from inhalation and dermal exposures for all conditions of use are in Section 4.2 (Table 4-14 through Table 4-24).

EPA evaluated exposures to workers, ONUs, general population, and consumers, using reasonably available monitoring and modeling data for inhalation, and dermal exposures, as applicable.

For the HBCD Risk Evaluation, EPA identified and evaluated as Potentially Exposed or Susceptible Subpopulations: workers, occupational non-users (ONUs), subsistence fishers, females of reproductive age, young children, and the highly exposed general population (and consumers) living near or with an HBCD point source. (Section 4.4.1).

The description of the data used for human health hazard is in Section 3. Uncertainties in the analysis are discussed in Section 4.3 and considered in the risk determination for each condition of use below, including that EPA was unable to model the potential effects of bioaccumulation in human tissues over time, EPA was unable to quantify ONU exposure due to lack of adequate data or relevant models, and estimated fish ingestion exposure is highly dependent on the selected Bioaccumulation Factor (BAF) value.

²¹ This risk determination is being issued under TSCA section 6(b) and the terms used, such as unreasonable risk, and the considerations discussed are specific to TSCA. Other statutes have different authorities and mandates and may involve risk considerations other than those discussed here.

5.1.1.1 Non-Cancer Risk Estimates

The risk estimates of non-cancer effects (MOEs) refers to adverse health effects associated with health endpoints other than cancer, including to the body's organ systems, such as thyroid effects, liver effects, and reproductive/developmental effects. The MOE is the point of departure (POD) (an approximation of the no-observed adverse effect level (NOAEL) or benchmark dose level (BMDL)) for a specific health endpoint divided by the exposure concentration for the specific scenario of concern. Section 3.2.5 presents the PODs for acute and chronic non-cancer effects for HBCD and Section 4.2 presents the MOEs for acute and chronic non-cancer effects.

The MOEs are compared to a benchmark MOE. The benchmark MOE accounts for the total uncertainty in a POD, including, as appropriate: (1) the variation in sensitivity among the members of the human population (*i.e.*, intrahuman/intraspecies variability); (2) the uncertainty in extrapolating animal data to humans (*i.e.*, interspecies variability); (3) the uncertainty in extrapolating from data obtained in a study with less-than-lifetime exposure to lifetime exposure (*i.e.*, extrapolating from subchronic to chronic exposure); and (4) the uncertainty in extrapolating from a lowest observed adverse effect level (LOAEL) rather than from a NOAEL. A lower benchmark MOE (*e.g.*, 30) indicates greater certainty in the data (because fewer of the default UFs relevant to a given POD as described above were applied). A higher benchmark MOE (*e.g.*, 1000) would indicate more uncertainty for specific endpoints and scenarios. However, these are often not the only uncertainties in a Risk Evaluation. The benchmark MOE for the most robust and sensitive acute non-cancer risks for HBCD is 100 (accounting for intraspecies and interspecies variability). The benchmark MOE for the most robust and sensitive chronic non-cancer risks for HBCD is 300 (accounting for interspecies and intraspecies variability as well as subchronic to chronic extrapolation). Additional information regarding the benchmark MOE is in Section 3.2.6.

5.1.1.2 Cancer Risk Estimates

EPA did not evaluate cancer risk from exposure to HBCD. Overall, given the limited data and mixed results between mammalian and non-mammalian systems, there is indeterminate evidence to make a conclusion on the genotoxicity of HBCD. The only experimental animal study to examine cancer endpoints concluded that HBCD was not carcinogenic, however, this study was only available as an incomplete report ([Kurokawa et al. 1984](#)). Therefore, according to the U.S. EPA Guidelines for Carcinogen Risk Assessment ([U.S. EPA 2005](#)), there is "inadequate information to assess the carcinogenic potential" of HBCD. As a result, this hazard was not carried forward for dose-response analysis or risk estimation. (Section 3.2.4.2)

5.1.1.3 Determining Unreasonable Risk of Injury to Health

Calculated risk estimates (MOEs or cancer risk estimates) can provide a risk profile by presenting a range of estimates for different health effects for different conditions of use. A calculated MOE that is less than the benchmark MOE indicates likely risk to human health of non-cancer effects. A calculated cancer risk estimate that is greater than the cancer benchmark indicates likely risk to human health of cancer. Whether those risks are unreasonable will depend upon other risk-related factors, such as the endpoint under consideration, the reversibility of effect, exposure-related considerations (*e.g.*, duration, magnitude, or frequency of exposure, or population exposed), and the confidence in the information used to inform the hazard and exposure values. A calculated MOE greater than the benchmark MOE or a calculated cancer risk estimate less than the benchmark, alone do not support a determination of unreasonable risk, since EPA may consider other risk based factors when making an unreasonable risk determination.

EPA may make an unreasonable risk determination when the risk affects the general population or a PESS that was identified as relevant. For workers (who are one example of PESS), when making an

unreasonable risk determination, EPA also makes assumptions regarding workplace practices and exposure controls, including engineering controls or use of personal protective equipment (PPE). However, EPA does not assume that ONUs use PPE. For each condition of use of HBCD with an identified risk for workers, EPA assumes, as a baseline, the use of a respirator with an APF of 5, 10, or 50. Similarly, EPA assumes the use of impervious gloves in industrial settings. However, EPA assumes that for some conditions of use, the use of appropriate respirators is not a standard industry practice, based on best professional judgment given the burden associated with the use of supplied-air respirators, including the expense of the equipment and the necessity of fit-testing and training for proper use. Once EPA has applied the appropriate PPE assumption for a particular condition of use in each unreasonable risk determination, in those instances when EPA assumes PPE is used, EPA also assumes that the PPE is used in a manner that achieves the stated APF or PF. EPA's decisions for unreasonable risk to workers are based on high-end exposure estimates, in order to capture not only exposures for PESS but also to account for the uncertainties related to whether or not workers are using PPE.

In the HBCD risk characterization, offspring loss was identified as the most robust and sensitive endpoint for non-cancer adverse effect from acute exposures and thyroid effects were identified as the most robust and sensitive endpoint for non-cancer adverse effects from chronic exposures for all conditions of use. However, additional risks associated with other adverse effects (*e.g.* liver effects, other reproductive/developmental effects) were also identified for acute and chronic exposures. Determining unreasonable risk by using offspring loss and thyroid effects will also include the unreasonable risk from other endpoints resulting from acute or chronic inhalation and dermal exposures.

When making a determination of unreasonable risk, the Agency has a higher degree of confidence where uncertainty is low. Similarly, EPA has high confidence in the hazard and exposure characterizations when, for example, the basis for the characterizations is measured or monitoring data or a robust model and the hazards identified for risk estimation are relevant for conditions of use. Where EPA has made assumptions in the scientific evaluation, whether or not those assumptions are protective is also a consideration. Additionally, EPA considers the central tendency and high-end scenarios when determining the unreasonable risk. High-end risk estimates (*e.g.*, 95th percentile) are generally intended to cover individuals or sub-populations with greater exposure (PESS) and central tendency risk estimates are generally estimates of average or typical exposure.

EPA may make a determination of no unreasonable risk for conditions of use where the substance's hazard and exposure potential, or where the risk-related factors described previously, lead the Agency to determine that the risks are not unreasonable.

5.1.2 Environment

EPA's Risk Evaluation identified adverse effects resulting from acute and chronic exposures to HBCD for both aquatic and terrestrial organisms for all conditions of use, as summarized in Section 3.1. The environmental hazard threshold is calculated for both aquatic and terrestrial organisms. The hazard threshold for aquatic organisms takes into account an assessment factor that represents uncertainties explained in Section 3.1.5, therefore allowing a concentration of concern (COC) to be derived. Limitations in data availability regarding HBCD toxicity to terrestrial organisms do not allow for an assessment factor to be used to derive a COC, therefore the hazard threshold is based on reported hazard effect concentrations reported by key studies summarized in Section 3.1.5. The description of the data used for environmental exposure is in Section 2.3. The environmental concentration is determined based on the levels of the chemical released to the environment (*e.g.*, surface water, sediment, soil, biota) under the conditions of use, based on the fate properties, release potential, and reasonably available

environmental monitoring data. Section 4.1. provides more detail regarding the risk quotient derivations for HBCD.

EPA calculated a risk quotient (RQ) to compare environmental concentrations against a hazard threshold. The environmental risk estimates from exposure to HBCD via water (*e.g.*, surface water and sediment) and air (*e.g.*, soil) releases are characterized in Section 4.1 (Table 4-3 through Table 4-7). Uncertainties in the analysis are discussed in Section 4.3 and considered in the risk determination for each condition of use below, including the fact that despite HBCD being a PBT, exposure to HBCD across and within media types were not aggregated to estimate risk (as explained in Section 4.1.3), therefore environmental risk may be underestimated for aquatic and terrestrial organisms.

5.1.2.1 Determining Unreasonable Risk of Injury to the Environment

Calculated risk estimates (RQs) can provide a risk profile by presenting a range of estimates for different environmental hazard effects for different conditions of use. A calculated RQ that is equal to or greater than one indicates likely risk to environmental health (exposure exceeds the hazard threshold), whereas a calculated RQ that is less than one indicates that there is unlikely to be risk to environmental health (exposure is less than the hazard threshold). Consistent with EPA's human health evaluations, the RQ is not treated as a bright line and other risk-based factors may be considered (*e.g.*, confidence in the hazard and exposure characterization, duration, magnitude, uncertainty) for purposes of making an unreasonable risk determination.

EPA may make an unreasonable risk determination when the risk affects organisms that are identified as being relevant. Based on the available hazard data for aquatic and terrestrial organisms, EPA based environmental risk for conditions of use on predicted media-specific HBCD concentrations. Although EPA acknowledges that due to the physical-chemical properties of HBCD that dietary exposure is likely, HBCD release information cannot be directly used to extrapolate tissue concentrations of prey of either aquatic or terrestrial organisms; monitoring data was primarily used for the trophic transfer estimation of HBCD (Section 3.1.3), and that is used to evaluate the potential for HBCD to undergo trophic transfer due to all activities and releases that likely contribute to HBCD background exposures. Due to the lack of HBCD hazard information regarding terrestrial organism exposure, terrestrial organism risk resulting from HBCD exposure is limited to that for soil organisms (*e.g.*, earthworms), and EPA acknowledges this uncertainty.

In the HBCD risk characterization, delayed hatching and reduced growth of offspring were identified as the most robust and sensitive endpoints for pelagic organisms due to acute and chronic exposures of HBCD, respectively. EPA evaluated algae risk separately from the categorization of an acute or chronic exposure, and unreasonable risk of reduced algae growth was evaluated. The most robust and sensitive endpoint identified for benthic organisms due to chronic HBCD exposure was reduced reproduction. EPA also identified reduced reproduction and survival of soil organisms due to chronic exposure to HBCD as being the most robust and sensitive endpoint.

When making a determination of unreasonable risk, the Agency has a higher degree of confidence where uncertainty is low. Similarly, EPA has high confidence in the hazard and exposure characterizations when, for example, the basis for the characterizations is measured or monitoring data or a robust model and the hazards identified for risk estimation are relevant for conditions of use. Where EPA has made assumptions in the scientific evaluation, whether or not those assumptions are protective is also a consideration. Additionally, EPA considers the central tendency and high-end scenarios when determining the unreasonable risk. High-end risk estimates (*e.g.*, 90th percentile) are generally intended

to cover organisms or populations with greater exposure (those inhabiting ecosystems near industries) and central tendency risk estimates are generally estimates of average or typical exposure.

EPA may make a determination of no unreasonable risk for conditions of use where the substance's hazard and exposure potential, or where the risk-related factors described previously, lead the Agency to determine that the risks are not unreasonable.

5.2 Detailed Unreasonable Risk Determinations by Condition of Use

Table 5-1. Categories and Subcategories of Conditions of Use Included in the Scope of the Risk Evaluation

Life Cycle Stage	Category ^a	Subcategory ^b	Unreasonable Risk	Detailed Risk Determination
Manufacture	Import	Import	yes	Section 5.2.1.1 and Section 5.2.2.1
Processing	Incorporated into formulation, mixture or reaction product	Flame retardants used in custom compounding of resin (<i>e.g.</i> , compounding in XPS masterbatch) and in solder paste	yes	Section 5.2.1.2 and Section 5.2.2.2
		Flame retardants used in plastics product manufacturing (manufacture of XPS and EPS foam; manufacture of structural insulated panels (SIPS) and automobile replacement parts from XPS and EPS foam)	yes	Section 5.2.1.3 and Section 5.2.2.3
	Recycling	Recycling of XPS and EPS foam, resin, panels containing HBCD	yes	Section 5.2.1.4 and Section 5.2.2.4
	Recycling	Recycling of electronics waste containing HIPs that contains HBCD	no	Section 5.2.1.5 and Section 5.2.2.5
Distribution	Distribution	Distribution	no	Section 5.2.1.6 and Section 5.2.2.6
Commercial/ consumer Use	Building/construction materials	Plastic articles (hard): construction and building materials covering large surface areas (<i>e.g.</i> , XPS/EPS foam insulation in residential, public and commercial buildings, and other structures) and solder paste	yes	Section 5.2.1.7 and Section 5.2.2.7
		Automobile replacement parts	no	Section 5.2.1.8
	Other	Plastic and other articles ^d	no	Section 5.2.1.8
		Formulated products (<i>e.g.</i> , adhesives and coatings) and articles (<i>e.g.</i> , electronics products and textiles)	no	Section 5.2.1.10
Disposal	Disposal	Land disposal (<i>e.g.</i> , EPS and XPS foam insulation)	yes	Section 5.2.1.10 and Section 5.2.2.8

Life Cycle Stage	Category ^a	Subcategory ^b	Unreasonable Risk	Detailed Risk Determination
		Land disposal of formulated products (<i>e.g.</i> , adhesives and coatings) and articles (<i>e.g.</i> , electronics products and textiles)	no	Section 5.2.1.11 and Section 5.2.2.9

^aThese categories of conditions of use appear in the Life Cycle Diagram, reflect CDR codes, and broadly represent conditions of use of HBCD in industrial and/or commercial settings and of consumer uses.

^bThese subcategories reflect more specific uses of HBCD

** Although EPA has identified both industrial and commercial uses here for purposes of distinguishing scenarios in this document, the Agency interprets the authority over “any manner or method of commercial use” under TSCA section 6(a)(5) to reach both.

5.2.1 Human Health

In addition to COU-specific determinations below, EPA also evaluated risks to the general population (Table 4-19) and other Potentially Exposed or Susceptible Subpopulations (PESS) (Table 4-29) based on aggregate general exposure to HBCD not associated with any particular COU. The PESS groups include subsistence fishers and newborns less than 1 year old. For each of these groups, EPA did not find unreasonable risk.

While HBCD is released to landfills, EPA determined the evaluation does not support an unreasonable risk determination to the general population via landfill (*e.g.*, construction and demolition landfill) leachate based on a qualitative assessment of HBCD’s migration through the landfill to groundwater and to receptors via groundwater ingestion or groundwater entering surface water. HBCD is a solid and likely to be entrained in a solid matrix (XPS/EPS foam) when disposed of in a landfill. HBCD’s high soil organic carbon partition coefficient and low water solubility indicates it will preferentially partition to soil organic carbon and exhibit very slow movement through soil to groundwater.

While HBCD is released to surface water, EPA determined during problem formulation that no further analysis beyond what was presented in the problem formulation document would be done for the drinking water exposure pathway in this Risk Evaluation. While this exposure pathway remains in the scope of the risk evaluation, EPA found no further analysis was necessary. EPA determined that the evaluation does not support an unreasonable risk determination to the general population via drinking water based on a qualitative assessment of the physical chemical properties and fate of HBCD in the environment as well as the absence of any detection of HBCD in monitored water samples.

5.2.1.1 Manufacturing – Import – (Import)

Section 6(b)(4)(A) unreasonable risk determination for import of HBCD: Does not present an unreasonable risk of injury to health (workers, ONUs, and highly exposed general population).

For workers, EPA found that there was no unreasonable risk of non-cancer effects from acute (offspring loss) or chronic (thyroid effects) inhalation or dermal exposures at the central tendency or high-end, when assuming use of PPE. For the highly exposed general population, EPA found that there was no unreasonable risk of non-cancer effects from acute (offspring loss) or chronic (thyroid effects) inhalation or fish ingestion at the moderate or highest sub-scenario exposure levels.

EPA’s determination that the import of HBCD does not present an unreasonable risk is based on the comparison of the risk estimates for non-cancer effects to the benchmarks (Table 4-14 through Table 4-17) and other considerations.

As explained in Section 5.1, EPA considered the health effects of HBCD, the exposures for the condition of use, and the uncertainties in the analysis, including uncertainties related to the exposures for ONUs. The key factors in the determination for this COU are:

- EPA assumes workers use PPE (respirators and gloves).
- For workers, when assuming use of respirators with APF of 5 and 10, the risk estimates of non-cancer effects from acute and chronic inhalation exposures at the central tendency and high-end are higher than the MOE and do not support an unreasonable risk determination (Table 4-27).
- EPA does not expect any level of dermal exposure to HBCD following proper use of impervious gloves. Therefore, risk estimates are not provided and risks are not identified for any exposure scenario when impervious gloves are assumed to be worn and used appropriately (Section 4.5.2.1).
- Exposures to ONUs are expected to be lower than those for workers. Risk estimates for inhalation exposure to ONUs were not quantified (Table 4-13).
- For the highly exposed general population, the risk estimates of non-cancer effects from acute and chronic air inhalation and fish ingestion at the moderate and highest sub-scenario exposure levels are above the MOE and do not support an unreasonable risk determination (

- Table 4-28).

In summary, the risk estimates, the health effects of HBCD, the exposures, and consideration of uncertainties support EPA's determination that there is no unreasonable risk of injury to health from the import of HBCD.

5.2.1.2 Processing – Incorporated into Formulation, Mixture or Reaction Product – Flame Retardants used in Custom Compounding of Resin (e.g., compounding in XPS masterbatch) and in Solder Paste

Section 6(b)(4)(A) unreasonable risk determination for processing of HBCD into a formulation: Does not present an unreasonable risk of injury to health (workers, ONUs, and highly exposed general population).

For workers, EPA found that there was no unreasonable risk of non-cancer effects from acute (offspring loss) or chronic (thyroid effects) inhalation or dermal exposures at the central tendency or high-end, when assuming use of PPE.

For the highly exposed general population, EPA found that there was no unreasonable risk of non-cancer effects from acute (offspring loss) or chronic (thyroid effects) inhalation or fish ingestion at the moderate or highest sub-scenario exposure levels.

EPA's determination that the processing of HBCD into a formulation, mixture or reaction product does not present an unreasonable risk is based on the comparison of the risk estimates for non-cancer effects to the benchmarks (Table 4-14 through Table 4-17) and other considerations.

As explained in Section 5.1, EPA considered the health effects of HBCD, the exposures for the condition of use, and the uncertainties in the analysis, including uncertainties related to the exposures for ONUs. The key factors in the determination for this COU are:

- EPA assumes workers use PPE (respirators and gloves).
- For workers, when assuming use of respirators with APF of 5 and 10, the risk estimates of non-cancer effects from acute and chronic inhalation exposures at the central tendency and high-end are higher than the MOE and do not support an unreasonable risk determination (Table 4-27).
- EPA does not expect any level of dermal exposure to HBCD following proper use of impervious gloves. Therefore, risk estimates are not provided and risks are not identified for any exposure scenario when impervious gloves are assumed to be worn and used appropriately (Section 4.5.2.1).
- Exposures to ONUs are expected to be lower than those for workers. Risk estimates for inhalation exposure to ONUs were not quantified (Table 4-13).
- For the highly exposed general population, the risk estimates of non-cancer effects from acute and chronic air inhalation and fish ingestion at the moderate and high sub-scenario exposure levels are above the MOE and do not support an unreasonable risk determination (

- Table 4-28).

In summary, the risk estimates, the health effects of HBCD, the exposures, and consideration of uncertainties support EPA's determination that there is no unreasonable risk of injury to health from processing HBCD into a formulation.

5.2.1.3 Processing – Incorporation into an Article – Flame Retardants used in Plastics Product Manufacturing (manufacture of XPS and EPS foam; manufacture of structural insulation panels (SIPS) and automobile replacement parts from XPS and EPS foam)

Section 6(b)(4)(A) unreasonable risk determination for Processing of HBCD into an article: Does not present an unreasonable risk of injury to health (workers, ONUs, and highly exposed general population).

For workers, EPA found that there was no unreasonable risk of non-cancer effects from acute (offspring loss) or chronic (thyroid effects) inhalation or dermal exposures at the central tendency or high-end, when assuming use of PPE.

For the highly exposed general population, EPA found that there was no unreasonable risk of non-cancer effects from acute (offspring loss) or chronic (thyroid effects) inhalation or fish ingestion at the moderate or highest sub-scenario exposure levels.

EPA's determination that the processing of HBCD into an article does not present an unreasonable risk is based on the comparison of the risk estimates for non-cancer effects to the benchmarks (Table 4-14 through Table 4-17) and other considerations.

As explained in Section 5.1, EPA considered the health effects of HBCD, the exposures for the condition of use, and the uncertainties in the analysis, including uncertainties related to the exposures for ONUs. The key factors in the determination for this COU are:

- EPA assumes workers use PPE (respirators and gloves).
- For workers, when assuming use of respirators with APF of 5 and 10, the risk estimates of non-cancer effects from acute and chronic inhalation exposures at the central tendency and high-end are higher than the MOE and do not support an unreasonable risk determination (Table 4-27).
- EPA does not expect any level of dermal exposure to HBCD following proper use of impervious gloves. Therefore, risk estimates are not provided and risks are not identified for any exposure scenario when impervious gloves are assumed to be worn and used appropriately (Section 4.5.2.1).
- Exposures for ONUs are expected to be lower than for workers. Risk estimates for inhalation exposure to ONUs were not quantified (Table 4-13).
- For the highly exposed general population, the risk estimates of non-cancer effects from acute and chronic air inhalation and fish ingestion at the moderate and high sub-scenario exposure levels are above the MOE and do not support an unreasonable risk determination (

- Table 4-28).

In summary, the risk estimates, the health effects of HBCD, the exposures, and consideration of uncertainties support EPA's determination that there is no unreasonable risk of injury to health from processing HBCD into an article.

5.2.1.4 Processing – Recycling – Recycling of XPS and EPS Foam, Resin, Panels containing HBCD

Section 6(b)(4)(A) unreasonable risk determination for recycling of XPS and EPS foam, resin, panels containing HBCD: Does not present an unreasonable risk of injury to health (workers, ONUs, and highly exposed general population).

For workers, EPA found that there was no unreasonable risk of non-cancer effects from acute (offspring loss) or chronic (thyroid effects) inhalation or dermal exposures at the central tendency or high-end, when assuming use of PPE.

For the highly exposed general population, EPA found that there was no unreasonable risk of non-cancer effects from acute (offspring loss) or chronic (thyroid effects) inhalation or fish ingestion at the moderate or highest sub-scenario exposure levels.

EPA's determination that the recycling of XPS and EPS foam, resin, and panels containing HBCD does not present an unreasonable risk is based on the comparison of the risk estimates for non-cancer effects to the benchmarks (Table 4-14 through Table 4-17) and other considerations.

As explained in Section 5.1, EPA considered the health effects of HBCD, the exposures for the condition of use, and the uncertainties in the analysis, including uncertainties related to the exposures for ONUs. The key factors in the determination for this COU are:

- EPA assumes workers use PPE (respirators and gloves).
- For workers, when assuming use of respirators with APF of 5 and 10, the risk estimates of non-cancer effects from acute and chronic inhalation exposures at the central tendency and high-end are higher than the MOE and do not support an unreasonable risk determination (Table 4-27).
- EPA does not expect any level of dermal exposure to HBCD following proper use of impervious gloves. Therefore, risk estimates are not provided and risks are not identified for any exposure scenario when impervious gloves are assumed to be worn and used appropriately (Section 4.5.2.1).
- Exposures for ONUs are expected to be lower than for workers. Risk estimates for inhalation exposure to ONUs were not quantified (Table 4-13).
- For the highly exposed general population, the risk estimates of non-cancer effects from acute and chronic air inhalation and fish ingestion at the moderate and highest sub-scenario exposure levels are above the MOE and do not support an unreasonable risk determination (

- Table 4-28).

In summary, the risk estimates, the health effects of HBCD, the exposures, and consideration of uncertainties support EPA's determination that there is no unreasonable risk of injury to health from recycling of XPS and EPS foam, resin, panels containing HBCD.

5.2.1.5 Processing – Recycling – Recycling of electronics waste containing HIPS that contain HBCD

Section 6(b)(4)(A) unreasonable risk determination for recycling of electronics waste containing HIPS that contain HBCD: Does not present an unreasonable risk of injury to health (workers, ONUs, and highly exposed general population).

For workers, EPA found that there was no unreasonable risk of non-cancer effects from acute (offspring loss) or chronic (thyroid effects) inhalation or dermal exposures at the central tendency or high-end, when assuming use of PPE.

For the highly exposed general population, EPA found that there was no unreasonable risk of non-cancer effects from acute (offspring loss) or chronic (thyroid effects) inhalation or fish ingestion at the highest or moderate sub-scenario exposure levels.

EPA's determination that the recycling of electronics waste containing HIPS that contain HBCD does not present an unreasonable risk is based on the comparison of the risk estimates for non-cancer effects to the benchmarks (Table 4-14 through Table 4-17) and other considerations.

As explained in Section 5.1, EPA considered the health effects of HBCD, the exposures for the condition of use, and the uncertainties in the analysis, including uncertainties related to the exposures for ONUs. The key factors in the determination for this COU are:

- Risk estimates are well above the benchmark MOE for non-cancer effects from acute or chronic exposures and do not support an unreasonable risk determination (Table 4-27).
- EPA assumes workers use PPE (respirators and gloves).
- For workers, when assuming use of respirators with APF of 5 and 10, the risk estimates of non-cancer effects from acute and chronic inhalation exposures at the central tendency and high-end are above the MOE (Table 4-27).
- EPA does not expect any level of dermal exposure to HBCD following proper use of impervious gloves. Therefore, risk estimates are not provided and risks are not identified for any exposure scenario when impervious gloves are assumed to be worn and used appropriately (Section 4.5.2.1).
- Exposures for ONUs are expected to be lower than for workers. Risk estimates for inhalation exposure to ONUs were not quantified (Table 4-13).
- For the highly exposed general population, the risk estimates of non-cancer effects from acute and chronic air inhalation and fish ingestion at the moderate and highest sub-scenario exposure levels are above the MOE and do not support an unreasonable risk determination (

- Table 4-28).

In summary, the risk estimates, the health effects of HBCD, the exposures, and consideration of uncertainties support EPA's determination that there is no unreasonable risk of injury to health from recycling of electronics waste containing HIPS that contains HBCD.

5.2.1.6 Distribution in Commerce – Distribution – Distribution

Section 6(b)(4)(A) unreasonable risk determination for distribution in commerce of HBCD: Does not present an unreasonable risk of injury to health (workers and ONUs).

For the purposes of the risk determination, distribution in commerce of HBCD is the transportation associated with the moving of HBCD in commerce. Activities related to distribution (*e.g.*, loading, unloading) are considered throughout the life cycle, rather than using a single distribution scenario. EPA assumes transportation of HBCD is conducted taking similar measures as the transportation of hazardous materials.

5.2.1.7 Commercial/Consumer Use – Building/Construction Materials – Plastic Articles (hard) Construction and Building Materials covering Large Surface Areas (*e.g.*, EPS/XPS foam insulation in residential, public and commercial buildings, and other structures) and Solder Paste

Section 6(b)(4)(A) unreasonable risk determination for commercial/consumer use of building/construction materials and solder paste: **Presents an unreasonable risk of injury to health (workers and ONUs).** Does not present an unreasonable risk to health for the highly exposed general population including consumers.

For workers and ONUs, EPA found that there was an unreasonable risk of non-cancer effects from chronic (thyroid effects) inhalation or dermal exposures at the high-end, without assuming use of PPE. For the highly exposed general population EPA found that there was no unreasonable risk of non-cancer effects from acute (offspring loss) or chronic (thyroid effects) air inhalation or fish ingestion at the highest or moderate sub-scenario exposure levels. In addition, for consumers, EPA found that there was no unreasonable risk of non-cancer effects from acute (offspring loss) or chronic (thyroid effects) exposure to dust and indoor air from installation of XPS/EPS foam insulation.

EPA's determination that commercial/consumer use of HBCD in building/construction materials by workers presents an unreasonable risk to health is based on the comparison of the risk estimates for non-cancer effects to the benchmarks (Table 4-14 through Table 4-17) and other considerations.

As explained in Section 5.1, EPA considered the health effects of HBCD, the exposures for the condition of use, and the uncertainties in the analysis, including uncertainties related to the exposures for ONUs. The key factors in the determination for this COU are:

- Exposure to HBCD for ONUs is expected to be similar to that of workers; risk estimates for inhalation exposure to ONUs were not quantified (Table 4-13).
- Workers installing XPS/EPS foam insulation and for ONUs working in residential, public, and commercial buildings, and other structures are unlikely to wear respiratory protection (Table 4-27).
- For workers installing XPS/EPS foam insulation and for ONUs working in residential, public, and commercial buildings, and other structures, when assuming no use of respirators, the risk

estimates to workers of non-cancer effects from chronic inhalation exposures at the high-end support an unreasonable risk determination (Table 4-27).

- For workers installing XPS/EPS foam insulation and for ONUs working in residential, public and commercial buildings, and other structures, when assuming no use of respirators, the risk estimates to workers of non-cancer effects from chronic inhalation exposures at the central tendency do not support an unreasonable risk determination (Table 4-27).
- For installation workers and ONUs, when assuming no use of respirators, the risk estimates to workers of non-cancer effects from acute inhalation exposures at the high-end and central tendency do not support an unreasonable risk determination (Table 4-27).
- For workers installing XPS/EPS foam insulation and for ONUs working in residential, public, and commercial buildings, and other structures, exposure is not expected when wearing impervious gloves (Table 4-27).
- For consumers, the risk estimates of non-cancer effects for acute and chronic exposures to dust and indoor air are above the MOE and do not support an unreasonable risk determination (

- Table 4-28).
- For workers using solder paste, exposure is not expected when wearing impervious gloves (Table 4-27).
- Consumers are not expected to be exposed to HBCD from use of solder paste (Section 2.2.13).
- For the highly exposed general population, the risk estimates of non-cancer effects from acute and chronic air inhalation and fish ingestion at the moderate and high sub-scenario exposure levels do not support an unreasonable risk determination (

- Table 4-28).

In summary, the risk estimates, the health effects of HBCD, the exposures, and consideration of uncertainties support EPA's determination that there is unreasonable risk of injury to health (for workers and ONUs) from use of building/construction materials and solder paste.

5.2.1.8 Commercial/Consumer Use – Other - Automobile Replacement Parts and Plastic and Other Articles

Section 6(b)(4)(A) unreasonable risk determination for commercial/consumer use of automobile replacement parts and use of plastic and other articles: Does not present an unreasonable risk of injury to health of (workers, ONUs, general population, consumers).

For consumers, EPA found that there was no unreasonable risk of non-cancer effects from acute (offspring loss) or chronic (thyroid effects) exposure to dust and indoor air from installation of automobile replacement parts. For consumers (1-2 year olds), EPA found that there was no unreasonable risk of non-cancer effects from acute (offspring loss) or chronic (thyroid effects) exposure from plastic and other articles.

EPA's determination that the commercial/consumer use in automobile replacement parts and plastic and other articles does not present an unreasonable risk is based on the comparison of the risk estimates for non-cancer effects to the benchmarks (Table 4-14 through Table 4-17) and other considerations.

As explained in Section 5.1, EPA considered the health effects of HBCD, the exposures for the condition of use, and the uncertainties in the analysis, including uncertainties related to the exposures for ONUs. The key factors in the determination for this COU are:

- For consumers, the risk estimates of non-cancer effects from acute and chronic exposure to dust and indoor air from installation of automobile replacement parts do not support an unreasonable risk determination (

- Table 4-28).
- Workers and ONUs are not expected to be exposed to HBCD from commercial use (installation) of automobile replacement parts (Section 2.2.8).
- Use of plastic and other articles is a consumer scenario and workers and ONUs are not expected to be exposed to HBCD from the condition of use (Section 2.4.4).
- For consumers (1 to 2-year olds), the risk estimates of non-cancer effects from acute and chronic exposure from plastic and other articles and do not support an unreasonable risk determination (

- Table 4-28).

In summary, the risk estimates, the health effects of HBCD, the exposures, and consideration of uncertainties support EPA's determination that there is no unreasonable risk of injury to health (consumers) from automobile replacement parts and mouthing of plastic and other articles.

5.2.1.9 Commercial/Consumer Use – Other – Formulated Products and Articles

Section 6(b)(4)(A) unreasonable risk determination for commercial/consumer use of formulated products and articles: Does not present an unreasonable risk of injury to health of consumers.

For workers and ONUs, when assuming the use of PPE, EPA found that there was no unreasonable risk of non-cancer effects from chronic (thyroid effects) exposure to dust and indoor air from formulated products and articles. For the general population and consumers, EPA found that there was no unreasonable risk of non-cancer effects from acute (offspring loss) or chronic (thyroid effects) exposure to dust and indoor air from formulated products and articles.

EPA's determination that the commercial/consumer use of formulated products and articles does not present an unreasonable risk is based on risks of exposure to background levels. As explained in Section 5.1, EPA considered the health effects of HBCD, the exposures for the condition of use, and the uncertainties in the analysis, including uncertainties related to the exposures for ONUs.

The key factors in the determination for this COU are:

- For workers and ONUs, the risk estimates of non-cancer effects from exposure to formulated products and articles do not support an unreasonable risk determination (Table 4-27).
- For the general population and consumers, the risk estimates of non-cancer effects from chronic exposure to formulated products and articles do not support an unreasonable risk determination (

- Table 4-28).

In summary, the risk estimates, the health effects of HBCD, the exposures, and consideration of uncertainties support EPA's determination that there is no unreasonable risk of injury to health from exposure to formulated products and articles.

**5.2.1.10 Disposal – Other Land Disposal (e.g. construction and demolition waste) –
Demolition and Disposal of XPS/EPS Foam Insulation Products in
Residential, Public and Commercial Buildings and Other Structures**

Section 6(b)(4)(A) unreasonable risk determination for disposal of building/construction materials:
Presents an unreasonable risk of injury to health (workers and ONUs); does not present an unreasonable risk of injury to health to the highly exposed general population.

For workers and ONUs, EPA found that there was an unreasonable risk of non-cancer effects from chronic (thyroid effects) inhalation at the high-end, without assuming use of PPE. For the highly exposed general population, EPA found that there was no unreasonable risk of non-cancer effects from acute (offspring loss) or chronic (thyroid effects) inhalation or fish ingestion at the highest or moderate sub-scenario exposure levels.

EPA's determination that demolition and disposal of XPS/EPS foam insulation products presents an unreasonable risk to health is based on the comparison of the risk estimates for non-cancer effects to the benchmarks (Table 4-14 through Table 4-17) and other considerations.

As explained in Section 5.1, EPA considered the health effects of HBCD, the exposures for the condition of use, and the uncertainties in the analysis, including uncertainties related to the exposures for ONUs. The key factors in the determination for this COU are:

- Exposure to HBCD for ONUs is expected to be similar to that of workers; risk estimates for inhalation exposure to ONUs were not quantified (Table 4-13).
- Workers exposed to HBCD when demolishing XPS/EPS foam insulation and for ONUs working in residential, public and commercial buildings are unlikely to wear respiratory protection (Table 4-27).
- For workers exposed to HBCD when demolishing XPS/EPS foam insulation and for ONUs working in residential, public and commercial buildings, when assuming no use of respirators, the risk estimates of non-cancer effects to workers from chronic inhalation exposures at the high-end support an unreasonable risk determination (Table 4-27).
- For workers exposed to HBCD when demolishing XPS/EPS foam insulation and for ONUs working in residential, public and commercial buildings, when assuming no use of respirators, the risk estimates of non-cancer effects from chronic inhalation exposures at the central tendency do not support an unreasonable risk determination (Table 4-27).
- For demolition workers and ONUs, when assuming no use of respirators in residential, public and commercial buildings, the risk estimates to workers of non-cancer effects from acute inhalation exposures at the high-end and central tendency do not support an unreasonable risk determination (Table 4-27).

- For the highly exposed general population, the risk estimates of non-cancer effects from acute and chronic air inhalation and fish ingestion at the moderate and highest sub-scenario exposure levels do not support an unreasonable risk determination (

- Table 4-28).

In summary, the risk estimates, the health effects of HBCD, the exposures, and consideration of uncertainties support EPA's determination that there is an unreasonable risk of injury to health (workers and ONUs) from demolition of EPS/XPS foam insulation in residential, public and commercial buildings, and other structures.

5.2.1.11 Disposal –Disposal of Formulated Products and Articles

Section 6(b)(4)(A) unreasonable risk determination for disposal of formulated products and articles:

Presents no unreasonable risk of injury to health (workers and ONUs); does not present an unreasonable risk of injury to health to the highly exposed the general population.

For workers and ONUs, EPA found that there was no unreasonable risk of non-cancer effects from chronic (thyroid effects) inhalation at the high-end, without assuming use of PPE. For the highly exposed general population, EPA found that there was no unreasonable risk of non-cancer effects from acute (offspring loss) or chronic (thyroid effects) inhalation or fish ingestion at the highest or moderate sub-scenario exposure levels.

EPA's determination that disposal of formulated products and articles presents an unreasonable risk to health is based on the comparison of the risk estimates for non-cancer effects to the benchmark MOE (Table 4-14 through Table 4-17) and other considerations.

As explained in Section 5.1, EPA considered the health effects of HBCD, the exposures for the condition of use, and the uncertainties in the analysis, including uncertainties related to the exposures for ONUs. The key factors in the determination for this COU are:

- Exposure to HBCD for ONUs is expected to be similar to that of workers; risk estimates for inhalation exposure to ONUs were not quantified (Table 4-13).
- Workers exposed to HBCD when demolishing XPS/EPS foam insulation and for ONUs working in residential, public and commercial buildings are unlikely to wear respiratory protection (Table 4-27).
- For workers exposed to HBCD when demolishing XPS/EPS foam insulation and for ONUs working in residential, public and commercial buildings, when assuming no use of respirators, the risk estimates of non-cancer effects to workers from chronic inhalation exposures at the high-end support an unreasonable risk determination (Table 4-27).
- For workers exposed to HBCD when demolishing XPS/EPS foam insulation and for ONUs working in residential, public and commercial buildings, when assuming no use of respirators, the risk estimates of non-cancer effects from chronic inhalation exposures at the central tendency do not support an unreasonable risk determination (Table 4-27).
- For demolition workers and ONUs, when assuming no use of respirators in residential, public and commercial buildings, the risk estimates to workers of non-cancer effects from acute inhalation exposures at the high-end and central tendency do not support an unreasonable risk determination (Table 4-27).

- For the highly exposed general population, the risk estimates of non-cancer effects from acute and chronic air inhalation and fish ingestion at the moderate and highest sub-scenario exposure levels do not support an unreasonable risk determination (

- Table 4-28;).

In summary, the risk estimates, the health effects of HBCD, the exposures, and consideration of uncertainties support EPA's determination that there is an unreasonable risk of injury to health (workers and ONUs) from disposal of formulated products and articles.

5.2.2 Environment

The unreasonable risk determinations in this section are based on the risk of adverse effects for aquatic and terrestrial organisms. Risk estimates are presented at Table 4-26 for both the 10th (high-end) and 50th percentile (central tendency) of estimated HBCD concentrations in surface water, sediment, and soil. For aquatic organisms, the hazard endpoint identified for acute exposure is the delay of zebrafish embryo hatching. The hazard endpoint identified for algae is reduction of growth. For chronic exposures, the endpoints identified are growth effects for water flea surviving young and reduced reproduction of California blackworms (Section 4.1.1.2). EPA also evaluated risks to terrestrial species from chronic exposure to HBCD in soil for earthworms.

In addition to evaluating risk of intended, known, and reasonably foreseen uses of HBCD, EPA also derived risk estimates based on monitoring data of HBCD in the environment that reflect releases of HBCD from those uses and historical releases from discontinued uses that are not intended, known, or reasonably foreseen to occur. RQs are equal to or above 1 (denoting risk) for all three hazard thresholds for pelagic organisms (algae, acute fish and chronic invertebrate COCs), and the one hazard threshold for benthic organisms (chronic blackworm invertebrate COC) based on measured monitoring surface water and sediment concentrations near industrial facilities, respectively. On the other hand, RQs were less than one for all aquatic organisms based on environmental monitoring data attained near general population sites. RQs were also less than one based on the hazard threshold for earthworms near industrial facilities and general population sites.

In regard to water releases, it is unlikely that three exposure scenarios (Installation of Automobile Replacement Parts, Formulation of Flux/Solder Pastes and Recycling of Electronics Waste Containing HIPS) will result in risk for aquatic organisms (pelagic and benthic) because EPA does not expect these scenarios to result in the release of HBCD into surface water or sediment. Similarly, in regard to air releases, it is unlikely that one exposure scenario (Installation of Automobile Replacement Parts) will result in risk for soil organisms because EPA does not expect these scenarios to result in the presence of HBCD in soil due to air deposition. However, although these exposure scenarios are not expected to have water and/or air releases of HBCD, it is possible that for a specific COU corresponding to these exposure scenarios, that there are other exposure scenarios characterizing a COU may have water or air releases of HBCD. Despite the unlikelihood of environmental risk due to either having media-specific releases that are less than the hazard value ($RQ < 1$) or the unlikely release of HBCD into specific medias, since modeled HBCD exposures were not aggregated with measured background concentrations of HBCD, current exposure scenario-related RQs may underestimate exposure. For the risk determination EPA assumes background levels of HBCD add an indeterminate level of risk to each COU but it is not aggregated quantitatively with the modeled HBCD media-specific concentrations.

5.2.2.1 Manufacturing – Import – (Import)

Section 6(b)(4)(A) unreasonable risk determination for import of HBCD: Presents an unreasonable risk of injury to the environment (aquatic organisms); does not present an unreasonable risk to terrestrial organisms.

For aquatic organisms, EPA found that there was an unreasonable risk of adverse effects from acute and chronic exposures at the high-end and central tendency of concentrations in surface water and sediment. There is also unreasonable risk of adverse effects to algae at the high-end concentration in surface water.

EPA's determination that the import of HBCD presents an unreasonable risk is based on the comparison of the risk estimates for adverse effects to the benchmarks (Table 4-26) and other considerations. As explained in Section 5.1, EPA considered the hazard of HBCD, the exposures for the condition of use, and the uncertainties in the analysis. The key factors in the determination for this COU are:

- For aquatic organisms, the risk estimates of adverse effects from acute and chronic exposures in surface water at the central tendency and high-end support an unreasonable risk determination. The risk estimates of adverse effects for algae due to high-end surface water concentrations also support an unreasonable risk determination.
- For aquatic organisms, the risk estimates of adverse effects from exposure in sediment at the central tendency and high-end support an unreasonable risk determination.
- For terrestrial organisms, the risk estimates of adverse effects from chronic exposure in soil do not support an unreasonable risk determination.

In summary, the risk estimates, the health effects of HBCD, the exposures, and consideration of uncertainties support EPA's determination that there is unreasonable risk of injury to the environment from the import of HBCD.

5.2.2.2 Processing – Incorporated into Formulation, Mixture or Reaction Product – Flame retardants used in Custom Compounding of Resin (e.g., compounding in XPS masterbatch) and in Solder Paste

Section 6(b)(4)(A) unreasonable risk determination for processing of HBCD into a formulation:
Presents an unreasonable risk of injury to the environment (aquatic organisms); does not present an unreasonable risk to terrestrial organisms.

For aquatic organisms, EPA found that there was an unreasonable risk of adverse effects from acute and chronic exposures at the high-end of concentrations in surface water and sediment. There is also unreasonable risk of adverse effects to algae at the high-end concentration in surface water.

EPA's determination that the processing of HBCD into formulation presents an unreasonable risk is based on the comparison of the risk estimates for adverse effects to the benchmarks (Table 4-26) and other considerations. As explained in Section 5.1, EPA considered the hazard of HBCD, the exposures for the condition of use, and the uncertainties in the analysis. The key factors in the determination for this COU are:

- For aquatic organisms, the risk estimates of adverse effects from acute and chronic exposures in surface water at the high-end support an unreasonable risk determination. The risk estimates of adverse effects for algae due to high-end surface water concentrations also support an unreasonable risk determination.
- For aquatic organisms, the risk estimates of adverse effects from exposure in sediment at the high-end support an unreasonable risk determination.

- For terrestrial organisms, the risk estimates of adverse effects from chronic exposure in soil do not support an unreasonable risk determination.

In summary, the risk estimates, the health effects of HBCD, the exposures, and consideration of uncertainties support EPA's determination that there is unreasonable risk of injury to the environment from processing HBCD into formulation.

5.2.2.3 Processing – Incorporation into an Article – Flame Retardants used in Plastics Product Manufacturing (manufacture of XPS and EPS foam; manufacture of structural insulation panels (SIPS) and automobile replacement parts from XPS and EPS foam)

Section 6(b)(4)(A) unreasonable risk determination for processing of HBCD into an article: Presents an unreasonable risk of injury to the environment (aquatic organisms); does not present an unreasonable risk to terrestrial organisms.

For aquatic organisms, EPA found that there was an unreasonable risk of adverse effects from acute and chronic exposures at the central tendency and high-end of concentrations in surface water and sediment. There is also unreasonable risk of adverse effects to algae at the central tendency and high-end concentrations in surface water.

EPA's determination that the processing of HBCD into articles presents an unreasonable risk is based on the comparison of the risk estimates for adverse effects to the benchmarks (Table 4-26) and other considerations. As explained in Section 5.1, EPA considered the hazard of HBCD, the exposures for the condition of use, and the uncertainties in the analysis. The key factors in the determination for this COU are:

- For aquatic organisms, the risk estimates of adverse effects from acute and chronic exposures in surface water at the central tendency and high-end support an unreasonable risk determination. There is also unreasonable risk of adverse effects to algae at the central tendency and high-end concentration in surface water.
- For aquatic organisms, the risk estimates of adverse effects from exposure in sediment at the central tendency and high-end support an unreasonable risk determination.
- For terrestrial organisms, the risk estimates of adverse effects from chronic exposure in soil do not support an unreasonable risk determination.

In summary, the risk estimates, the health effects of HBCD, the exposures, and consideration of uncertainties support EPA's determination that there is unreasonable risk of injury to the environment from processing HBCD into an article.

5.2.2.4 Processing – Recycling – Recycling of XPS and EPS Foam, Resin, Panels Containing HBCD

Section 6(b)(4)(A) unreasonable risk determination for recycling of XPS and EPS form, resin, and panels containing HBCD: **Presents an unreasonable risk of injury to the environment (aquatic organisms)**; does not present an unreasonable risk to terrestrial organisms.

For aquatic organisms, EPA found that there was an unreasonable risk of adverse effects from acute and chronic exposures at the central tendency and high-end of concentrations in surface water and sediment.

There is also unreasonable risk of adverse effects to algae at the central tendency and high-end concentrations in surface water.

EPA's determination that the recycling of XPS and EPS foam, resin, panels containing HBCD presents an unreasonable risk is based on the comparison of the risk estimates for adverse effects to the benchmarks (Table 4-26) and other considerations. As explained in Section 5.1, EPA considered the hazard of HBCD, the exposures for the condition of use, and the uncertainties in the analysis. The key factors in the determination for this COU are:

- For aquatic organisms, the risk estimates of adverse effects from acute and chronic exposures in surface water at the central tendency and high-end support an unreasonable risk determination. The risk estimates of adverse effects for algae due to central tendency and high-end surface water concentrations also support an unreasonable risk determination.
- For aquatic organisms, the risk estimates of adverse effects from chronic exposure in sediment at the central tendency and high-end support an unreasonable risk determination.
- For terrestrial organisms, the risk estimates of adverse effects from chronic exposure in soil do not support an unreasonable risk determination.

In summary, the risk estimates, the health effects of HBCD, the exposures, and consideration of uncertainties support EPA's determination that there is unreasonable risk of injury to the environment from recycling of XPS and EPS foam, resin, panels containing HBCD.

5.2.2.5 Processing – Recycling – Recycling of Electronics Waste Containing HIPS that Contain HBCD

Section 6(b)(4)(A) unreasonable risk determination for recycling of electronics waste containing HIPS that contain HBCD: Does not present an unreasonable risk of injury to the environment (aquatic and terrestrial organisms).

For aquatic and terrestrial organisms, EPA found that there was no unreasonable risk of adverse effects from exposures.

EPA's determination that recycling of electronics waste containing HIPS that contain HBCD does not present an unreasonable risk is based on EPA's expectation that HBCD is not released from this exposure scenario into surface water; therefore it is unlikely that there will be risk to aquatic organisms (both pelagic and benthic). It is unlikely that air releases of HBCD from the recycling of electronics waste containing HIPS that contain HBCD will result in risk to soil organisms.

In summary, EPA determined that there is no unreasonable risk of injury to the environment from the recycling of electronics waste containing HIPS that contain HBCD.

5.2.2.6 Distribution in Commerce – Distribution – Distribution

Section 6(b)(4)(A) unreasonable risk determination for distribution in commerce of HBCD: Does not present an unreasonable risk of injury to the environment (aquatic and terrestrial organisms).

For the purposes of the risk determination, distribution in commerce of HBCD is the transportation associated with the moving of HBCD in commerce. Activities related to distribution (*e.g.*, loading, unloading) are considered throughout the life cycle, rather than using a single distribution scenario. EPA

assumes transportation of HBCD is conducted taking similar measures as the transportation of hazardous materials.

5.2.2.7 Commercial/Consumer Use – Building/Construction Materials – Plastic Articles (hard) Construction and Building Materials Covering Large Surface Areas (e.g., EPS/XPS foam insulation in residential, public and commercial buildings, and other structures) and Solder Paste

Section 6(b)(4)(A) unreasonable risk determination for use of construction and building materials and solder paste containing HBCD: Presents an unreasonable risk of injury to the environment (aquatic organisms); does not present an unreasonable risk to terrestrial organisms.

For aquatic organisms, EPA found that there was an unreasonable risk of adverse effects from acute exposures at the central tendency and high-end of concentrations in surface water and chronic exposures at the high-end of concentrations in sediment. There is also unreasonable risk of adverse effects to algae at the central tendency and high-end concentrations in surface water.

EPA's determination that the use of construction and building materials and solder paste containing HBCD presents an unreasonable risk is based on the comparison of the risk estimates for adverse effects to the benchmarks (Table 4-26) and other considerations. As explained in Section 5.1, EPA considered the hazard of HBCD, the exposures for the condition of use, and the uncertainties in the analysis. The key factors in the determination for this COU are:

- For aquatic organisms, the risk estimates of adverse effects from acute exposures in surface water at central tendency and high-end support an unreasonable risk determination. The risk estimates of adverse effects for algae due to central tendency and high-end surface water concentrations also support an unreasonable risk determination. The risk estimates of adverse effects from chronic exposures in sediment at high-end support an unreasonable risk determination.
- For aquatic organisms, the risk estimates of adverse effects from chronic exposure in surface water do not support an unreasonable risk determination.
- For terrestrial organisms, the risk estimates of adverse effects from chronic exposure in soil do not support an unreasonable risk determination.

In summary, the risk estimates, the health effects of HBCD, the exposures, and consideration of uncertainties support EPA's determination that there is unreasonable risk of injury to the environment from commercial/consumer use of construction and building materials and solder paste.

5.2.2.8 Disposal – Other Land Disposal (e.g. construction and demolition waste) – Demolition and Disposal of XPS/EPS Foam Insulation Products in Residential, Public and Commercial Buildings and Other Structures

Section 6(b)(4)(A) unreasonable risk determination for disposal of HBCD: Presents an unreasonable risk of injury to the environment (aquatic organisms); does not present an unreasonable risk to terrestrial organisms.

For aquatic organisms, EPA found that there was an unreasonable risk of adverse effects from acute and chronic exposures at the central tendency and high-end of concentrations in surface water. There is also unreasonable risk of adverse effects to algae at the central tendency and high-end concentrations in surface water.

EPA's determination that the disposal of HBCD presents an unreasonable risk is based on the comparison of the risk estimates for adverse effects to the benchmarks (Table 4-26) and other considerations. As explained in Section 5.1, EPA considered the hazard of HBCD, the exposures for the condition of use, and the uncertainties in the analysis. The key factors in the determination for this COU are:

- For aquatic organisms, the risk estimates of adverse effects from acute exposures in surface water at the central tendency and high-end support an unreasonable risk determination.
- For aquatic organisms, the risk estimates of adverse effects from chronic exposure in surface water at the high-end support an unreasonable risk determination.
- For aquatic organisms, the risk estimates of adverse effects for algae in surface water at the central tendency and high-end support an unreasonable risk determination.
- For aquatic organisms, the risk estimates of adverse effects from exposure in sediment do not support an unreasonable risk determination.
- For terrestrial organisms, the risk estimates of adverse effects from chronic exposure in soil do not support an unreasonable risk determination.

In summary, the risk estimates, the health effects of HBCD, the exposures, and consideration of uncertainties support EPA's determination that there is unreasonable risk of injury to the environment from disposal.

5.2.2.9 Disposal – Land Disposal of Formulated Products and Articles

Section 6(b)(4)(A) unreasonable risk determination for disposal of HBCD: Does not present an unreasonable risk of injury to the environment (aquatic organisms); does not present an unreasonable risk to terrestrial organisms.

For aquatic organisms, EPA found that there was no unreasonable risk of adverse effects from acute and chronic exposures at the central tendency and high-end of concentrations in surface water. There is also no unreasonable risk of adverse effects to algae at the central tendency and high-end concentrations in surface water.

EPA's determination that the disposal of HBCD does not present an unreasonable risk is based on the comparison of the risk estimates for adverse effects to the benchmarks (Table 4-26) and other considerations. As explained in Section 5.1, EPA considered the hazard of HBCD, the exposures for the condition of use, and the uncertainties in the analysis. The key factors in the determination for this COU are:

- For aquatic organisms, the risk estimates of adverse effects from acute exposures in surface water at the central tendency and high-end do not support an unreasonable risk determination.

- For aquatic organisms, the risk estimates of adverse effects from chronic exposure in surface water at the high-end do not support an unreasonable risk determination.
- For aquatic organisms, the risk estimates of adverse effects for algae in surface water at the central tendency and high-end do not support an unreasonable risk determination.
- For aquatic organisms, the risk estimates of adverse effects from exposure in sediment do not support an unreasonable risk determination.
- For terrestrial organisms, the risk estimates of adverse effects from chronic exposure in soil do not support an unreasonable risk determination.

In summary, the risk estimates, the health effects of HBCD, the exposures, and consideration of uncertainties support EPA's determination that there is no unreasonable risk of injury to the environment from disposal.

5.3 Changes to the Unreasonable Risk Determination from Draft Risk Evaluation to Final Risk Evaluation

In response to peer review and public comments on the draft Risk Evaluation, EPA conducted additional assessments, including estimation of environmental risk at the 10th percentile concentrations of concern in surface water, sediment, and soil. For the human health assessment, EPA assumed that workers and ONUs are unlikely to use respirator protection for installation or demolition of XPS/EPS foam insulation and therefore did not apply in the risk determination the assumption that PPE is used for these two uses. EPA also added assessments and unreasonable risk determinations for select PESS groups not associated with releases from a particular COU. Ultimately EPA made determinations of unreasonable risk for six of the 10 conditions of use.

5.4 Unreasonable Risk Determination Conclusion

5.4.1 No Unreasonable Risk Determinations

TSCA section 6(b)(4) requires EPA to conduct Risk Evaluations to determine whether chemical substances present unreasonable risk under their conditions of use. In conducting Risk Evaluations, "EPA will determine whether the chemical substance presents an unreasonable risk of injury to health or the environment under each condition of use within the scope of the Risk Evaluation ..." 40 CFR 702.47. Under EPA's implementing regulations, "[a] determination by EPA that the chemical substance, under one or more of the conditions of use within the scope of the risk evaluation, does not present an unreasonable risk of injury to health or the environment will be issued by order and considered to be a final Agency action, effective on the date of issuance of the order." 40 CFR 702.49(d).

EPA has determined that the following conditions of use of HBCD do not present an unreasonable risk of injury to health or the environment:

- Processing; recycling of electronics waste containing HIPS that contains HBCD (Section 5.2.1.1, Section 5.2.2)
- Distribution (Section 5.2.1.6, Section 493)
- Consumer/Commercial Use of replacement automobile parts (Section 5.2.1.8)
- Consumer/Commercial Use of plastics and other articles (Section 5.2.1.8)

- Consumer/Commercial Use of formulated products and articles (Section 5.2.1.9)
- Disposal of formulated products and articles (Section 5.2.1.11, Section 5.2.2.9)

This subsection of the final Risk Evaluation therefore constitutes the order required under TSCA section 6(i)(1), and the “no unreasonable risk” determinations in this subsection are considered to be final agency action effective on the date of issuance of this order. All assumptions that went into reaching the determinations of no unreasonable risk for these conditions of use, including any considerations excluded for these conditions of use, are incorporated into this order.

The support for each determination of “no unreasonable risk” is set forth in Section 5.2 of the final Risk Evaluation, “Detailed Unreasonable Risk Determinations by Condition of Use.” This subsection also constitutes the statement of basis and purpose required by TSCA section 26(f).

5.4.2 Unreasonable Risk Determinations

EPA has determined that the following conditions of use of HBCD present an unreasonable risk of injury to the environment and two conditions of use (Commercial/consumer use of construction/building materials and solder paste, and Disposal) also present an unreasonable risk of injury to health:

- Manufacturing (Import) (Section 5.2.1.1, Section 5.2.2, Section 4, Section 3, and 2.)
- Processing of HBCD: incorporation into a formulation, mixture, or reaction products (Section 5.2.1.1, Section 5.2.2, Section 4, Section 3, and 2.)
- Processing of HBCD: incorporation into an article (Section 5.2.1.1, Section 5.2.2, Section 4, Section 3, and 2.)
- Recycling of XPS/EPS foam, resin, panels containing HBCD (Section 5.2.1.1, Section 5.2.2, Section 4, Section 3, and 2.)
- Commercial/consumer use of HBCD in construction/building materials and solder paste (Section 5.2.1.1, Section 5.2.2, Section 4, Section 3, and 2.)
- Disposal of HBCD in construction and demolition waste (Section 5.2.1.1, Section 5.2.2, Section 4, Section 3, and 2.)

EPA will initiate TSCA section 6(a) risk management actions on these conditions of use as required under TSCA section 6(c)(1). Pursuant to TSCA section 6(i)(2), the “unreasonable risk” determinations for these conditions of use are not considered final agency action.

REFERENCES

- [A.C.H. Foam Technologies](#). (2007). Material safety data sheet (MSDS): foam-control EPS and foam-control EPS with perform guard. Westminster, CO: ACH Foam Technologies.
<http://www.octaform.com/wp-content/uploads/EPSMSDS.pdf>.
- [Abb, M; Stahl, B; Lorenz, W](#). (2011). Analysis of brominated flame retardants in house dust. *Chemosphere* 85: 1657-1663. <http://dx.doi.org/10.1016/j.chemosphere.2011.06.022>.
- [Abbot, W](#). (2001). Summary of workplace and exposure monitoring data for Hexabromocyclododecane. Abbot, W.
- [Abdallah, MA; Harrad, S](#). (2009). Personal exposure to HBCDs and its degradation products via ingestion of indoor dust. *Environ Int* 35: 870-876.
<http://dx.doi.org/10.1016/j.envint.2009.03.002>.
- [Abdallah, MA; Harrad, S](#). (2011). Tetrabromobisphenol-A, hexabromocyclododecane and its degradation products in UK human milk: relationship to external exposure. *Environ Int* 37: 443-448. <http://dx.doi.org/10.1016/j.envint.2010.11.008>.
- [Abdallah, MA; Harrad, S; Covaci, A](#). (2008). Hexabromocyclododecanes and tetrabromobisphenol-A in indoor air and dust in Birmingham, U.K: implications for human exposure. *Environ Sci Technol* 42: 6855-6861. <http://dx.doi.org/10.1021/es801110a>.
- [Abdallah, MA; Pawar, G; Harrad, S](#). (2015). Evaluation of 3D-human skin equivalents for assessment of human dermal absorption of some brominated flame retardants. *Environ Int* 84: 64-70.
<http://dx.doi.org/10.1016/j.envint.2015.07.015>.
- [Abdallah, MA; Sharkey, M; Berresheim, H; Harrad, S](#). (2018). Hexabromocyclododecane in polystyrene packaging: A downside of recycling? *Chemosphere* 199: 612-616.
<http://dx.doi.org/10.1016/j.chemosphere.2018.02.084>.
- [Abdallah, MA; Uchea, C; Chipman, JK; Harrad, S](#). (2014). Enantioselective biotransformation of hexabromocyclododecane by in vitro rat and trout hepatic sub-cellular fractions. *Environ Sci Technol* 48: 2732-2740. <http://dx.doi.org/10.1021/es404644s>.
- [Abdallah, MAE; Harrad, S](#). (2010). Modification and Calibration of a Passive Air Sampler for Monitoring Vapor and Particulate Phase Brominated Flame Retardants in Indoor Air: Application to Car Interiors. *Environ Sci Technol* 44: 3059-3065.
<http://dx.doi.org/10.1021/es100146r>.
- [ACC](#). (2003a). Hexabromocyclododecane (HBCD): A Prolonged Sediment Toxicity Test with *Hyalella azteca* Using Spiked Sediment with 2% Total Organic Carbon. In *Wildlife International Ltd* (pp. 150). (OTS: NA; 8EHQ Num: FYI-03-01472; DCN: 84040000010; TSCATS RefID: NA; CIS: FYI-03-01472). Easton, MD.
- [ACC](#). (2003b). Hexabromocyclododecane (HBCD): A Prolonged Sediment Toxicity Test with *Hyalella azteca* Using Spiked Sediment with 5% Total Organic Carbon. (OTS: NA; 8EHQ Num: FYI-03-01472; DCN: 84040000010; TSCATS RefID: NA; CIS: FYI-03-01472).
- [ACC/North American Flame Retardant Alliance](#) (2019): Public Comment EPA-HQ-OPPT-2019-0238-0020.
- [Airlite Plastics Co dba Fox, B](#). (2008). Material safety data sheet (MSDS): fox blocks insulating concrete forms (ICF). Omaha, NE: Airlite Plastics Co dba Fox Blocks.
https://formingsolutionsicf.com/wp-content/uploads/2015/07/Fox-Blocks-tPMt-Appendix-A_1-MSDS.pdf.
- [Al Bitar, F](#). (2004). Hazardous chemicals in Belgian house dust: Report on chemical content in house dust samples collected in Belgian homes and offices. Brussels, Belgium: Greenpeace Belgium.
<http://www.greenpeace.org/eu-unit/Global/eu-unit/reports-briefings/2007/hazardous-chemicals-in-belgian-2.pdf>.

- Albemarle. (2005). Hexabromocyclododecane IUCLID Data Set (CAS No. 25637-99-4): Submitted to U.S. EPA's High Production Volume (HPV) Chemical Program.
<http://www.epa.gov/chemrtk/pubs/summaries/cyclodod/c13459rr.pdf>
- Albemarle. (2017). [Personal communication between Wesley Ware, Albemarle Corporation, and Sue Slotnick, EPA, regarding Hexabromocyclododecane (HBCD)]. EPA-HQ-OPPT-2016-0735-0113 in regulations.gov.
- Alexander, BM; Baxter, CS. (2016). Flame-retardant contamination of firefighter personal protective clothing - A potential health risk for firefighters. *J Occup Environ Hyg* 13: D148-D155.
<http://dx.doi.org/10.1080/15459624.2016.1183016>
- Ali, N; Dirtu, AC; Van Den Eede, N; Goosey, E; Harrad, S; Neels, H; 'T Mannetje, A; Coakley, J; Douwes, J; Covaci, A. (2012). Occurrence of alternative flame retardants in indoor dust from New Zealand: indoor sources and human exposure assessment. *Chemosphere* 88: 1276-1282.
<http://dx.doi.org/10.1016/j.chemosphere.2012.03.100>.
- Allchin, CR; Morris, S. (2003). Hexabromocyclododecane (HBCD) diastereoisomers and brominated diphenyl ether congener (BDE) residues in edible fish from the rivers Skerne and Tees, UK. *Organohalogen Compd* 61: 41-44.
- Allen, JG; Stapleton, HM; Vallarino, J; Mcneely, E; Mcclean, MD; Harrad, SJ; Rauert, CB; Spengler, JD. (2013). Exposure to flame retardant chemicals on commercial airplanes. *Environ Health* 12: 17. <http://dx.doi.org/10.1186/1476-069X-12-17>.
- Allgood, JM; Jimah, T; Mcclaskey, CM; La Guardia, MJ; Hammel, SC; Zeineddine, MM; Tang, IW; Runnerstrom, MG; Ogunseitan, OA. (2016). Potential human exposure to halogenated flame-retardants in elevated surface dust and floor dust in an academic environment. *Environ Res* 153: 55-62. <http://dx.doi.org/10.1016/j.envres.2016.11.010>.
- Alliance of Automobile Manufacturers. (2018). Cover letter and attachment from Automobile Alliance 11-19-18 [Personal Communication].
- Almughamsi, H; Whalen, MM. (2016). Hexabromocyclododecane and tetrabromobisphenol A alter secretion of interferon gamma (IFN- γ) from human immune cells. *Arch Toxicol* 90: 1695-1707.
<http://dx.doi.org/10.1007/s00204-015-1586-6>.
- Al-Odaini, NA; Shim, WJ; Han, GM; Jang, M; Hong, SH. (2015). Enrichment of hexabromocyclododecanes in coastal sediments near aquaculture areas and a wastewater treatment plant in a semi-enclosed bay in South Korea. *Sci Total Environ* 505: 290-298.
<http://dx.doi.org/10.1016/j.scitotenv.2014.10.019>.
- An, J; Guo, P; Shang, Y; Zhong, Y; Zhang, X; Yu, Y; Yu, Z. (2016). The "adaptive responses" of low concentrations of HBCD in L02 cells and the underlying molecular mechanisms. *Chemosphere* 145: 68-76. <http://dx.doi.org/10.1016/j.chemosphere.2015.11.071>.
- An, J; Zou, W; Chen, C; Zhong, FY; Yu, QZ; Wang, QJ. (2013). The cytological effects of HBCDs on human hepatocyte L02 and the potential molecular mechanism. *J Environ Sci Health A Tox Hazard Subst Environ Eng* 48: 1333-1342. <http://dx.doi.org/10.1080/10934529.2013.781875>.
- Aniagu, SO; Williams, TD; Allen, Y; Katsiadaki, I; Chipman, JK. (2008). Global genomic methylation levels in the liver and gonads of the three-spine stickleback (*Gasterosteus aculeatus*) after exposure to hexabromocyclododecane and 17-beta oestradiol. *Environ Int* 34: 310-317.
<http://dx.doi.org/10.1016/j.envint.2007.03.009>.
- Anim, AK; Drage, DS; Goonetilleke, A; Mueller, JF; Ayoko, GA. (2017). Distribution of PBDEs, HBCDs and PCBs in the Brisbane River estuary sediment. *Mar Pollut Bull* 120: 165-173.
<http://dx.doi.org/10.1016/j.marpolbul.2017.05.002>.
- Anisuzzaman, S; Whalen, MM. (2016). Tetrabromobisphenol A and hexabromocyclododecane alter secretion of IL-1 β from human immune cells. *J Immunotoxicol* 13: 403-416.
<http://dx.doi.org/10.3109/1547691X.2015.1111960>.
- Anon. (2015). ICL-IP closes HBCD flame retardant production line. *Additives for Polymers* 2015: 7-8.

- Anselmo, HMR; Koerting, L; Devito, S; van den Berg, JHJ; Dubbeldam, M; Kwadijk, C; Murk, AJ. (2011). Early life developmental effects of marine persistent organic pollutants on the sea urchin *Psammechinus miliaris*. *Ecotoxicol Environ Saf* 74: 2182-2192.
<http://dx.doi.org/10.1016/j.ecoenv.2011.07.037>.
- Antignac, JP; Main, KM; Virtanen, HE; Boquien, CY; Marchand, P; Venisseau, A; Guiffard, I; Bichon, E; Wohlfahrt-Veje, C; Legrand, A; Boscher, C; Skakkebaek, NE; Toppari, J; Le Bizec, B. (2016). Country-specific chemical signatures of persistent organic pollutants (POPs) in breast milk of French, Danish and Finnish women. *Environ Pollut* 218: 728-738.
<http://dx.doi.org/10.1016/j.envpol.2016.07.069>.
- Au, SY; Lee, CM; Weinstein, JE; van den Hurk, P; Klaine, SJ. (2017). Trophic transfer of microplastics in aquatic ecosystems: Identifying critical research needs [Review]. *Integr Environ Assess Manag* 13: 505-509. <http://dx.doi.org/10.1002/ieam.1907>
- Aufderheide, J; Jones, A; MacGregor, JA; Nixon, WB. (2003). Effect of hexabromocyclododecane on the survival and reproduction of the earthworm, *Eisenia fetida* (pp. 94). (ABC Study No. 47222). Columbia, MO, and Easton, MD: ABC Laboratories and Wildlife International Ltd.
- Ausó, E; Lavado-Autric, R; Cuevas, E; Del Rey, FE; Morreale De Escobar, G; Berbel, P. (2004). A moderate and transient deficiency of maternal thyroid function at the beginning of fetal neocortinogenesis alters neuronal migration. *Endocrinology* 145: 4037-4047.
<http://dx.doi.org/10.1210/en.2004-0274>.
- Avio, CG; Gorbi, S; Regoli, F. (2015). Experimental development of a new protocol for extraction and characterization of microplastics in fish tissues: First observations in commercial species from Adriatic Sea. *Mar Environ Res* 111: 18-26. <http://dx.doi.org/10.1016/j.marenvres.2015.06.014>
- Aylward, LL; Hays, SM. (2011). Biomonitoring-based risk assessment for hexabromocyclododecane (HBCD) [Review]. *Int J Hyg Environ Health* 214: 179-187.
<http://dx.doi.org/10.1016/j.ijheh.2011.02.002>.
- Bakir, A; O'Connor, IA; Rowland, SJ; Hendriks, AJ; Thompson, RC. (2016). Relative importance of microplastics as a pathway for the transfer of hydrophobic organic chemicals to marine life. *Environ Pollut* 219: 56-65.
- Barghi, M; Shin, ES; Son, MH; Choi, SD; Pyo, H; Chang, YS. (2016). Hexabromocyclododecane (HBCD) in the Korean food basket and estimation of dietary exposure. *Environ Pollut* 213: 268-277. <http://dx.doi.org/10.1016/j.envpol.2016.02.026>.
- Barker, DJP. (2007). The origins of the developmental origins theory. *J Intern Med* 261: 412-417.
<http://dx.doi.org/10.1111/j.1365-2796.2007.01809.x>
- Barregard. (2003). Abstract P1.1-15 [Abstract]. In Annual Conference of the International Society of Exposure Analysis.
- BASF. (1990). Report on the study of the acute oral toxicity of hexabromocyclododecane in the mouse with cover letter dated 031290 [TSCA Submission]. (86900000383). Wyandotte, MI: BASF Corporation.
<https://ntrl.ntis.gov/NTRL/dashboard/searchResults.xhtml?searchQuery=OTS0522946>
- BASF. (2000). Cytogenetic study in vivo with of hexabromocyclododecane in the mouse micronucleus test after two intraperitoneal administrations. (Project No. 26MO100/004018). Ludwigshafen, Germany: BASF Aktiengesellschaft.
- BASF. (2015). Safety data sheet (SDS): styropek BF-222 M. Florham Park, NJ: BASF Corporation.
http://www2.basf.us/DocToolWeb/DisplayDoc?oname=30246572&appid=Plastics_MSDS_Search&rend=pdf.
- BASF. (2017). Personal communication between Jodi Visco, BASF, and Sue Slotnick, EPA, regarding Hexabromocyclododecane (HBCD).

- Bernal, J. (2015). Thyroid hormones in brain development and function. In LJ De Groot; G Chrousos; K Dungan; KR Feingold; A Grossman; JM Hershman; C Koch; M Korbonits; R McLachlan; M New; J Purnell; R Rebar; F Singer; A Vinik (Eds.). South Dartmouth, MA: MDText.com, Inc.
- Bernhard, A; Berntssen, MH; Lundebye, AK; Røyneberg Alvheim, A; Secher Myrmel, L; Fjære, E; Torstensen, BE; Kristiansen, K; Madsen, L; Brattelid, T; Rasinger, JD. (2016). Marine fatty acids aggravate hepatotoxicity of α -HBCD in juvenile female BALB/c mice. *Food Chem Toxicol* 97: 411-423. <http://dx.doi.org/10.1016/j.fct.2016.10.002>.
- Besseling, E; Wegner, A; Foekema, EM; van den Heuvel-Greve, MJ; Koelmans, AA. (2013). Effects of microplastic on fitness and PCB bioaccumulation by the lugworm *Arenicola marina* (L.). *Environ Sci Technol* 47: 593-600. <http://dx.doi.org/10.1021/es302763x>
- Bevington, C; Guo, Z; Hong, T; Hubbard, H; Wong, E; Sleasman, K; Hetfield, C. (2017). A Modeling Approach for Quantifying Exposures from Emissions of Spray Polyurethane Foam Insulation in Indoor Environments. In J Sebroski; M Mason (Eds.), (pp. 199-227). West Conshohocken, PA: ASTM International. <https://doi.org/10.1520/STP158920150045>.
- Bieseemeier, JA. (1996). Followup response letter from Great Lakes Chemical Corporation to KemI. Dated 19 December 1996. Bieseemeier, JA
- Boyles, E; Tan, H; Wu, Y; Nielsen, CK; Shen, L; Reiner, EJ; Chen, D. (2017). Halogenated flame retardants in bobcats from the midwestern United States. *Environ Pollut* 221: 191-198. <http://dx.doi.org/10.1016/j.envpol.2016.11.063>.
- Brandtsma, SH; Leonards, P; Leslie, HA; de Boer, J. (2015). Tracing organophosphorus and brominated flame retardants and plasticizers in an estuarine food web. *Sci Total Environ* 505: 22-31. <http://dx.doi.org/10.1016/j.scitotenv.2014.08.072>.
- Brandtsma, SH; Van der Ven, LT; De Boer, J; Leonards, PE. (2009). Identification of hydroxylated metabolites of hexabromocyclododecane in wildlife and 28-days exposed Wistar rats. *Environ Sci Technol* 43: 6058-6063. <http://dx.doi.org/10.1021/es900879k>.
- Burger, J. (2002). Daily consumption of wild fish and game: Exposures of high-end recreationists. *Int J Environ Health Res* 12: 343-354. <http://dx.doi.org/10.1080/0960312021000056393>.
- Burkhart, JE; Short, S. (1995). Health Hazard Evaluation Report HETA 91-0354-2532, South Dade Disposal Site, Goulds, Florida. (NTIS/02988621_3). Burkhart, JE; Short, S.
- Cahill, TM; Cousins, I; Mackay, D. (2003). Development and application of a generalized physiologically based pharmacokinetic model for multiple environmental contaminants. *Environ Toxicol Chem* 22: 26-34. <http://dx.doi.org/10.1002/etc.5620220104>.
- Campine. (2017). Personal communication between Hilde Goovaert, Campine, and Sue Slotnick, EPA, regarding Hexabromocyclododecane (HBCD).
- Canbaz, D; Lebre, MC; Logiantara, A; van Ree, R; van Rij, LS. (2016a). Indoor pollutant hexabromocyclododecane enhances house dust mite-induced activation of human monocyte-derived dendritic cells. *J Immunotoxicol* 13: 1-7. <http://dx.doi.org/10.1080/1547691X.2016.1200224>.
- Canbaz, D; Logiantara, A; Hamers, T; van Ree, R; van Rij, LS. (2016b). Indoor Pollutant Hexabromocyclododecane Has a Modest Immunomodulatory Effect on House Dust Mite Induced Allergic Asthma in Mice. *Environ Sci Technol* 50: 405-411. <http://dx.doi.org/10.1021/acs.est.5b05348>.
- Cantón, RF; Peijnenburg, AA; Hoogenboom, RL; Piersma, AH; van der Ven, LT; van den Berg, M; Heneweer, M. (2008). Subacute effects of hexabromocyclododecane (HBCD) on hepatic gene expression profiles in rats. *Toxicol Appl Pharmacol* 231: 267-272. <http://dx.doi.org/10.1016/j.taap.2008.04.013>.
- Cao, X; Lu, Y; Zhang, Y; Khan, K; Wang, C; Baninla, Y. (2018). An overview of hexabromocyclododecane (HBCDs) in environmental media with focus on their potential risk

and management in China [Review]. *Environ Pollut* 236: 283-295.

<http://dx.doi.org/10.1016/j.envpol.2018.01.040>

Carignan, CC; Abdallah, MA; Wu, N; Heiger-Bernays, W; Mcclean, MD; Harrad, S; Webster, TF. (2012). Predictors of tetrabromobisphenol-A (TBBP-A) and hexabromocyclododecanes (HBCD) in milk from Boston mothers. *Environ Sci Technol* 46: 12146-12153.

<http://dx.doi.org/10.1021/es302638d>.

Carr, SA; Liu, J; Tesoro, AG. (2016). Transport and fate of microplastic particles in wastewater treatment. *Water Res* 91: 174-182.

Census Bureau. (2012). Code Lists and Crosswalks - Census 2012 Detailed Industry Code List [Database]. Retrieved from <http://www.census.gov/people/io/methodology/>

Census Bureau. (2015). Statistics of U.S. Businesses (SUSB).

<https://www.census.gov/data/tables/2015/econ/susb/2015-susb-annual.html>.

Census Bureau. (2016). Survey of Income and Program Participation - SIPP Introduction and History [Database]. Retrieved from <http://www.census.gov/programs-surveys/sipp/about/sipp-introduction-history.html>

Chen, D; La Guardia, MJ; Luellen, DR; Harvey, E; Mainor, TM; Hale, RC. (2011). Do temporal and geographical patterns of HBCD and PBDE flame retardants in U.S. fish reflect evolving industrial usage? *Environ Sci Technol* 45: 8254-8261. <http://dx.doi.org/10.1021/es201444w>.

Choksi, NY; Jahnke, GD; St Hilaire, C; Shelby, M. (2003). Role of Thyroid Hormones in Human and Laboratory Animal Reproductive Health [Review]. *Birth Defects Res B Dev Reprod Toxicol* 68: 479-491. <http://dx.doi.org/10.1002/bdrb.10045>.

Christen, V; Crettaz, P; Oberli-Schrämml, A; Fent, K. (2010). Some flame retardants and the antimicrobials triclosan and triclocarban enhance the androgenic activity in vitro. *Chemosphere* 81: 1245-1252. <http://dx.doi.org/10.1016/j.chemosphere.2010.09.031>.

Coelho, SD; Sousa, AC; Isobe, T; Kim, JW; Kunisue, T; Nogueira, AJ; Tanabe, S. (2016). Brominated, chlorinated and phosphate organic contaminants in house dust from Portugal. *Sci Total Environ* 569-570: 442-449. <http://dx.doi.org/10.1016/j.scitotenv.2016.06.137>.

Conley, K; Clum, A; Deepe, J; Lane, H; Beckingham, B. (2019). Wastewater treatment plants as a source of microplastics to an urban estuary: Removal efficiencies and loading per capita over one year. *Water Research: X* 3: 100030.

Covaci, A; Roosens, L; Dirtu, AC; Waegeneers, N; Van Overmeire, I; Neels, H; Goeyens, L. (2009). Brominated flame retardants in Belgian home-produced eggs: levels and contamination sources. *Sci Total Environ* 407: 4387-4396.

CPSC. (2001). CPSC staff exposure and risk assessment of flame retardant chemicals in residential upholstered furniture. Bethesda, MD. <http://dx.doi.org/10.13140/RG.2.1.3291.6646>.

Critfc. (1994). A fish consumption survey of the Umatilla, Nez Perce, Yakama, and Warm Springs Tribes of the Columbia River Basin. (Technical Report 93-4). Portland, OR. <http://www.deq.idaho.gov/media/895853-fish-consumption-survey-1994.pdf>.

Crump, D; Chiu, S; Egloff, C; Kennedy, SW. (2008). Effects of hexabromocyclododecane and polybrominated diphenyl ethers on mRNA expression in chicken (*Gallus domesticus*) hepatocytes. *Toxicol Sci* 106: 479-487. <http://dx.doi.org/10.1093/toxsci/kfn196>.

Crump, D; Egloff, C; Chiu, S; Letcher, RJ; Chu, S; Kennedy, SW. (2010). Pipping success, isomer-specific accumulation, and hepatic mRNA expression in chicken embryos exposed to HBCD. *Toxicol Sci* 115: 492-500. <http://dx.doi.org/10.1093/toxsci/kfq068>.

D'Hollander, W; Roosens, L; Covaci, A; Cornelis, C; Reynders, H; Campenhout, KV; Voogt, P, d; Bervoets, L. (2010). Brominated flame retardants and perfluorinated compounds in indoor dust from homes and offices in Flanders, Belgium. *Chemosphere* 81: 478-487. <http://dx.doi.org/10.1016/j.chemosphere.2010.07.043>.

- Darnerud, P; Lignell, S; Aune, M; Isaksson, M; Cantillana, T; Redeby, J; Glynn, A. (2015). Time trends of polybrominated diphenylether (PBDE) congeners in serum of Swedish mothers and comparisons to breast milk data. *Environ Res* 138: 352-360.
<http://dx.doi.org/10.1016/j.envres.2015.02.031>.
- Darnerud, PO. (2003). Toxic effects of brominated flame retardants in man and in wildlife [Review]. *Environ Int* 29: 841-853. [http://dx.doi.org/10.1016/S0160-4120\(03\)00107-7](http://dx.doi.org/10.1016/S0160-4120(03)00107-7).
- Daso, AP; Rohwer, ER; Koot, DJ; Okonkwo, JO. (2017). Preliminary screening of polybrominated diphenyl ethers (PBDEs), hexabromocyclododecane (HBCDD) and tetrabromobisphenol A (TBBPA) flame retardants in landfill leachate. *Environ Monit Assess* 189: 418.
<http://dx.doi.org/10.1007/s10661-017-6131-z>.
- Davis, A; Gift, JS; Woodall, GM; Narotsky, MG; Fourman, GL. (2009). The role of developmental toxicity studies in acute exposure assessments: analysis of single-day vs. multiple-day exposure regimens. *Regul Toxicol Pharmacol* 54: 134-142. <http://dx.doi.org/10.1016/j.yrtph.2009.03.006>.
- Davis, JW; Gonsior, SJ; Marty, GT. (2003a). Evaluation of aerobic and anaerobic transformation of hexabromocyclododecane in aquatic sediment systems. (Dow Study ID 021081). Arlington, VA: American Chemistry Council.
- Davis, JW; Gonsior, SJ; Marty, GT. (2003b). Evaluation of aerobic and anaerobic transformation of hexabromocyclododecane in soil. (Dow Study ID 021082). Arlington, VA: American Chemistry Council.
- Davis, JW; Gonsior, S; Marty, G; Ariano, J. (2005). The transformation of hexabromocyclododecane in aerobic and anaerobic soils and aquatic sediments. *Water Res* 39: 1075-1084.
<http://dx.doi.org/10.1016/j.watres.2004.11.024>.
- Davis, JW; Gonsior, SJ; Markham, DA; Friederich, U; Hunziker, RW; Ariano, JM. (2006). Biodegradation and product identification of [¹⁴C]hexabromocyclododecane in wastewater sludge and freshwater aquatic sediment. *Environ Sci Technol* 40: 5395-5401.
<http://dx.doi.org/10.1021/es060009m>.
- De Boer, J; Allchin, C; Zegers, B; Boon, JP; Brandsma, SH; Morris, S; Kruijt, AW; Van Der Veen, I; Van Hesseligen, JM; Haftka, JJH. (2002). HBCD and TBBP-A in sewage sludge, sediments and biota, including interlaboratory study. In RIVO - the Netherlands Institute for Fisheries Research (pp. 40). (RIVO report number CO33/02). Ymuiden and Yerseke, Netherlands: De Boer, J; Allchin, C; Zegers, B; Boon, JP; Brandsma, SH; Morris, S; Kruijt, AW; Van Der Veen, I; Van Hesseligen, JM; Haftka, JJH.
[https://yosemite.epa.gov/oppts/epatscat8.nsf/by+Service/8298B71C48D0FADD85256EEB004A5440/\\$File/89030000021.pdf](https://yosemite.epa.gov/oppts/epatscat8.nsf/by+Service/8298B71C48D0FADD85256EEB004A5440/$File/89030000021.pdf).
- de Boer, J; Leslie, HA; Leonards, PE; Bersuder, P; Morris, S; Allchin, CR. (2004). Screening and time trend study of decabromodiphenylether and hexabromocyclododecane in birds (pp. 4). de Boer, J; Leslie, HA; Leonards, PE; Bersuder, P; Morris, S; Allchin, CR.
http://dtsc.ca.gov/bfr2013/abstract_download/2004/upload/Individual%20Papers/BFR2004%20Abstract%20025%20deBoer.pdf.
- de Wit, CA; Björklund, JA; Thuresson, K. (2012). Tri-decabrominated diphenyl ethers and hexabromocyclododecane in indoor air and dust from Stockholm microenvironments 2: indoor sources and human exposure. *Environ Int* 39: 141-147.
<http://dx.doi.org/10.1016/j.envint.2011.11.001>.
- Deng, J; Yu, L; Liu, C; Yu, K; Shi, X; Yeung, LW; Lam, PK; Wu, RS; Zhou, B. (2009). Hexabromocyclododecane-induced developmental toxicity and apoptosis in zebrafish embryos. *Aquat Toxicol* 93: 29-36. <http://dx.doi.org/10.1016/j.aquatox.2009.03.001>.
- Desjardins, D; Macgregor, J; Krueger, H. (2004). Final report: hexabromocyclododecane (HBCD): a 72-hour toxicity test with the marine diatom (*Skeletonema costatum*). (Project Number: 439A-125). Easton, MD: Desjardins, D; Macgregor, J; Krueger, H.

- Desjardins, D; MacGregor, JA; Krueger, HO. (2005). Final report. Chapter 1, Hexabromocyclododecane (HBCD): A 72-hour toxicity test with the marine diatom (*Skeletonema costatum*) using a co-solvent. Easton, MD: Wildlife International Ltd.
- DiversiFoam, P. (2015). Safety data sheet: certifoam. Rockford, MN: DiversiFoam Products. <https://www.diversifoam.com/pdf/CertiFoam-SDS.pdf>.
- Dodds, WK; Oakes, RM. (2004). A technique for establishing reference nutrient concentrations across watersheds affected by humans. *Limnology and Oceanography: Methods* 2: 333-341. <http://dx.doi.org/10.4319/lom.2004.2.333>.
- Dodson, RE; Perovich, LJ; Covaci, A; Van den Eede, N; Jonas, AC; Dirtu, AC; Brody, JG; Rudel, RA. (2012). After the PBDE phase-out: a broad suite of flame retardants in repeat house dust samples from California. *Environ Sci Technol* 46: 13056-13066. <http://dx.doi.org/10.1021/es303879n>.
- Dow Chemical. (2017). [Notes from phone call between Shawn Hunter, Dow Chemicals, and Sue Slotnick, EPA, regarding Hexabromocyclododecane (HBCD)].
- Dow Chemical Pacific, L. (2018). Material safety data sheet (MSDS): Styrofoam RTM-GV-NC-X Extruded. Wan Chai, Hong Kong: Dow Chemical Pacific Limited. <https://webcache.googleusercontent.com/search?q=cache:ncdz8MbJuJUJ:https://www.dow.com/en-US/ShowPDF.ashx%3Fid%3D090003e8808177d3+&cd=1&hl=en&ct=clnk&gl=us>.
- Drage, D; Mueller, JF; Birch, G; Eaglesham, G; Hearn, LK; Harrad, S. (2015). Historical trends of PBDEs and HBCDs in sediment cores from Sydney estuary, Australia. *Sci Total Environ* 512-513: 177-184. <http://dx.doi.org/10.1016/j.scitotenv.2015.01.034>.
- Drage, DS; Newton, S; de Wit, CA; Harrad, S. (2016). Concentrations of legacy and emerging flame retardants in air and soil on a transect in the UK West Midlands. *Chemosphere* 148: 195-203. <http://dx.doi.org/10.1016/j.chemosphere.2016.01.034>.
- Driffield, M; Harmer, N; Bradley, E; Fernandes, AR; Rose, M; Mortimer, D; Dicks, P. (2008). Determination of brominated flame retardants in food by LC-MS/MS: diastereoisomer-specific hexabromocyclododecane and tetrabromobisphenol A. *Food Addit Contam Part A Chem Anal Control Expo Risk Assess* 25: 895-903. <http://dx.doi.org/10.1080/02652030701882999>.
- Drottar, KR; Krueger, HO. (1998). Hexabromocyclododecane (HBCD): a flow-through life-cycle toxicity test with the cladoceran (*Daphnia magna*): Final report, with cover letter dated 5/18/1998 (pp. 80). (Wildlife International Ltd. Project Number: 439A-I08). Easton, MD: Wildlife International Ltd. [https://yosemite.epa.gov/oppts/epatscat8.nsf/by+Service/5A64B9CFE5710E8085256930004C5068/\\$File/84980000035.pdf](https://yosemite.epa.gov/oppts/epatscat8.nsf/by+Service/5A64B9CFE5710E8085256930004C5068/$File/84980000035.pdf).
- Drottar, KR; Krueger, HO. (2000). Hexabromocyclododecane (HBCD): A flow-through bioconcentration test with the rainbow trout (*Oncorhynchus mykiss*). Easton, MD: Wildlife International Ltd.
- Drottar, KR; Macgregor, JA; Krueger, HO. (2001). Hexabromocyclododecane (HBCD): An early life-stage toxicity test with the rainbow trout (*Onchorhynchus mykiss*). (PROJECT NUMBER: 439A-112; 8EHQ-01201-15037). Easton, MD: Wildlife International Ltd.
- Du, M; Fang, C; Qiu, L; Dong, S; Zhang, X; Yan, C. (2015). Diastereoisomer-specific effects of hexabromocyclododecanes on hepatic aryl hydrocarbon receptors and cytochrome P450s in zebrafish (*Danio rerio*). *Chemosphere* 132: 24-31. <http://dx.doi.org/10.1016/j.chemosphere.2015.02.049>.
- Du, M; Lin, L; Yan, C; Wang, C; Zhang, X. (2013). Enantiomer-specific bioaccumulation and depuration of hexabromocyclododecanes in zebrafish (*Danio Rerio*). *J Hazard Mater* 248-249: 167-171. <http://dx.doi.org/10.1016/j.jhazmat.2012.12.046>.
- Du, M; Lin, L; Yan, C; Zhang, X. (2012a). Diastereoisomer- and enantiomer-specific accumulation, depuration, and bioisomerization of hexabromocyclododecanes in zebrafish (*Danio rerio*). *Environ Sci Technol* 46: 11040-11046. <http://dx.doi.org/10.1021/es302166p>.

- Du, M; Zhang, D; Yan, C; Zhang, X. (2012b). Developmental toxicity evaluation of three hexabromocyclododecane diastereoisomers on zebrafish embryos. *Aquat Toxicol* 112-113: 1-10. <http://dx.doi.org/10.1016/j.aquatox.2012.01.013>.
- e-Steward. (2020). List Recyclers [Website]. <http://e-stewards.org/data/list-recyclers/>.
- EC/HC (Environment Canada and Health Canada). (2011). Screening Assessment Report on Hexabromocyclododecane (pp. 1-125). Ottawa, Canada: EC/HC (Environment Canada and Health Canada). <http://www.ec.gc.ca/ese-ees/default.asp?lang=En&n=7882C148-1#a4>.
- ECB. (2003). Technical guidance document on risk assessment: Part II. (EUR 20418 EN/2). Luxembourg: Office for Official Publications of the European Communities. http://ihcp.jrc.ec.europa.eu/our_activities/public-health/risk_assessment_of_Biocides/doc/tgd/tgdpart2_2ed.pdf.
- ECB. (2008). Risk assessment: Hexabromocyclododecane. Cas-No.: 25637-99-4. Luxembourg: European Inventory of Existing Commercial Chemical Substances, Office for Official Publications of the European Communities. <https://echa.europa.eu/documents/10162/661bff17-dc0a-4475-9758-40bdd6198f82>
- ECHA. (2008a). Guidance on information requirements and chemicals safety assessment: Supporting reference guidelines, chapters R12-R20. Helsinki, Finland. <http://echa.europa.eu/web/guest/guidance-documents/guidance-on-information-requirements-and-chemical-safety-assessment>.
- ECHA. (2008b). Risk assessment: hexabromocyclododecane. Helsinki, Finland. <https://echa.europa.eu/documents/10162/661bff17-dc0a-4475-9758-40bdd6198f82>.
- ECHA. (2009a). Background document for hexabromocyclododecane and all major diastereoisomers identified. Helsinki, Finland. https://echa.europa.eu/documents/10162/13640/hbccdd_en.pdf.
- ECHA. (2009b). Data on manufacture, import, export, uses and releases of HBCDD as well as information on potential alternatives to its use. In IOM Consulting, supported by BRE, PFA and Entec (pp. 108). (ECHA/2008/2). Helsinki, Finland. https://echa.europa.eu/documents/10162/13640/tech_rep_hbccdd_en.pdf.
- ECHA. (2009c). Prioritisation and Annex XIV background information: hexabromocyclododecane. Helsinki, Finland. <https://echa.europa.eu/documents/10162/42ddec00-863a-4cff-abd2-6d4b39abe114>.
- ECHA. (2017a). Adsorption/desorption: hexabromocyclododecane. Helsinki, Finland. Retrieved from <https://echa.europa.eu/registration-dossier/-/registered-dossier/15003/5/5/2#>
- ECHA. (2017b). Chemical safety report: Hexabromocyclododecane and all major diastereoisomers identified. Helsinki, Finland. <https://echa.europa.eu/documents/10162/7959599c-20e2-4d13-a1df-94fcdd23434e>.
- ECHA. (2017c). Chemical safety report: Hexabromocyclododecane and all major diastereoisomers identified, Part 2. Helsinki, Finland. <https://echa.europa.eu/documents/10162/ab191f7e-a290-4d75-b253-da14ce3dd076>.
- Eggesbø, M; Thomsen, C; Jørgensen, JV; Becher, G; Odland, JØ; Longnecker, MP. (2011). Associations between brominated flame retardants in human milk and thyroid-stimulating hormone (TSH) in neonates. *Environ Res* 111: 737-743. <http://dx.doi.org/10.1016/j.envres.2011.05.004>.
- EINECS. (2008). Risk assessment: Hexabromocyclododecane. Cas-No.: 25637-99-4. Luxembourg: European Inventory of Existing Commercial Chemical Substances, Office for Official Publications of the European Communities. <https://echa.europa.eu/documents/10162/661bff17-dc0a-4475-9758-40bdd6198f82>.
- Eljarrat, E; de la Cal, A; Raldua, D; Duran, C; Barcelo, D. (2005). Brominated flame retardants in *Alburnus alburnus* from Cinca River Basin (Spain). *Environ Pollut* 133: 501-508. <http://dx.doi.org/10.1016/j.envpol.2004.06.017>

- [Eljarrat, E; de la Cal, A; Raldua, D; Duran, C; Barceló, D.](#) (2004). Occurrence and bioavailability of polybrominated diphenyl ethers and hexabromocyclododecane in sediment and fish from the Cinca River, a tributary of the Ebro River (Spain). *Environ Sci Technol* 38: 2603-2608. <http://dx.doi.org/10.1021/es0301424>
- [Eljarrat, E; Guerra, P; Martínez, E; Farré, M; Alvarez, JG; López-Teijón, M; Barceló, D.](#) (2009). Hexabromocyclododecane in human breast milk: levels and enantiomeric patterns. *Environ Sci Technol* 43: 1940-1946. <http://dx.doi.org/10.1021/es802919e>.
- [Ema, M; Fujii, S; Hirata-Koizumi, M; Matsumoto, M.](#) (2008). Two-generation reproductive toxicity study of the flame retardant hexabromocyclododecane in rats. *Reprod Toxicol* 25: 335-351. <http://dx.doi.org/10.1016/j.reprotox.2007.12.004>.
- [Energy Recovery, C.](#) (2018). 2018 Directory of waste-to-energy facilities. Energy Recovery Council. <http://energyrecoverycouncil.org/wp-content/uploads/2019/10/ERC-2018-directory.pdf>.
- [Engler, RE.](#) (2012). The complex interaction between marine debris and toxic chemicals in the ocean [Review]. *Environ Sci Technol* 46: 12302-12315. <http://dx.doi.org/10.1021/es3027105>
- [EPS Industry Alliance.](#) (2017). Preliminary information on manufacturing, processing, distribution, use, and disposal: Cyclic aliphatic bromide cluster (HBCD). OCSPP. Public comment. (EPA-HQ-OPPT-2016-0735-0026).
- [Eriksson, P; Fischer, C; Wallin, M; Jakobsson, E; Fredriksson, A.](#) (2006). Impaired behaviour, learning and memory, in adult mice neonatally exposed to hexabromocyclododecane (HBCDD). *Environ Toxicol Pharmacol* 21: 317-322. <http://dx.doi.org/10.1016/j.etap.2005.10.001>.
- [Esslinger, S; Becker, R; Jung, C; Schröter-Kermani, C; Bremser, W; Nehls, I.](#) (2011a). Temporal trend (1988-2008) of hexabromocyclododecane enantiomers in herring gull eggs from the German coastal region. *Chemosphere* 83: 161-167. <http://dx.doi.org/10.1016/j.chemosphere.2010.12.047>.
- [Esslinger, S; Becker, R; Maul, R; Nehls, I.](#) (2011b). Hexabromocyclododecane enantiomers: microsomal degradation and patterns of hydroxylated metabolites. *Environ Sci Technol* 45: 3938-3944. <http://dx.doi.org/10.1021/es1039584>.
- [Esslinger, S; Becker, R; Müller-Belecke, A; Bremser, W; Jung, C; Nehls, I.](#) (2010). HBCD stereoisomer pattern in mirror carps following dietary exposure to pure gamma-HBCD enantiomers. *J Agric Food Chem* 58: 9705-9710. <http://dx.doi.org/10.1021/jf101469q>.
- [Ethyl Corporation.](#) (1990a). Genetic toxicology rat hepatocyte primary culture/DNA repair test on hexabromocyclododecane with cover letter dated 030890. (TSCATS/405817. OTS0522234. Doc I.D. 86900000163). Baton Rouge, LA. <https://ntrl.ntis.gov/NTRL/dashboard/searchResults.xhtml?searchQuery=OTS0522234>.
- [Ethyl Corporation.](#) (1990b). Genetic toxicology salmonella/microsomal assay on hexabromocyclododecane with cover letter dated 030890 [TSCA Submission]. (TSCATS/405818. OTS0522235. Doc I.D. 86900000164). Baton Rouge, LA. <https://ntrl.ntis.gov/NTRL/dashboard/searchResults.xhtml?searchQuery=OTS0522235>.
- [Fa, S; Pogrmic-Majkic, K; Samardzija, D; Hrubik, J; Glisic, B; Kovacevic, R; Andric, N.](#) (2015). HBCDD-induced sustained reduction in mitochondrial membrane potential, ATP and steroidogenesis in peripubertal rat Leydig cells. *Toxicol Appl Pharmacol* 282: 20-29. <http://dx.doi.org/10.1016/j.taap.2014.11.001>.
- [Fa, S; Samardzija, D; Odzic, L; Pogrmic-Majkic, K; Kaisarevic, S; Kovacevic, R; Andric, N.](#) (2014). Hexabromocyclododecane facilitates FSH activation of ERK1/2 and AKT through epidermal growth factor receptor in rat granulosa cells. *Arch Toxicol* 88: 345-354. <http://dx.doi.org/10.1007/s00204-013-1133-2>.
- [Fangstrom, B; Athanasiadou, M; Athanassiadis, I; Bignert, A; Grandjean, P; Weihe, P; Bergman, A.](#) (2005). Polybrominated diphenyl ethers and traditional organochlorine pollutants in fulmars (*Fulmarus glacialis*) from the Faroe Islands. *Chemosphere* 60: 836-843. <http://dx.doi.org/10.1016/j.chemosphere.2005.01.065>.

- Fängström, B; Athanassiadis, I; Odsjö, T; Norén, K; Bergman, A. (2008). Temporal trends of polybrominated diphenyl ethers and hexabromocyclododecane in milk from Stockholm mothers, 1980-2004. *Mol Nutr Food Res* 52: 187-193. <http://dx.doi.org/10.1002/mnfr.200700182>.
- Fent, KW; Evans, DE; Babik, K; Striley, C; Bertke, S; Kerber, S; Smith, D; Horn, GP. (2018). Airborne contaminants during controlled residential fires. *J Occup Environ Hyg* 15(5): 399-412. <http://dx.doi.org/https://doi.org/10.1080/15459624.2018.1445260>
- Fent, KW; Horn, GP; DeCrane, S. (2015). Firefighters' Perspective on Flame Retardants. https://www.sfpe.org/page/FPE_2015_Q4_4
- Fernandes, AR; Mortimer, D; Rose, M; Smith, F; Panton, S; Garcia-Lopez, M. (2016). Bromine content and brominated flame retardants in food and animal feed from the UK. *Chemosphere* 150: 472-478. <http://dx.doi.org/10.1016/j.chemosphere.2015.12.042>.
- Fernie, KJ; Martinson, SC; Bird, DM; Ritchie, IJ; Letcher, RJ. (2011). Reproductive changes in American kestrels (*Falco sparverius*) in relation to exposure to technical hexabromocyclododecane flame retardant. *Environ Toxicol Chem* 30: 2570-2575. <http://dx.doi.org/10.1002/etc.652>.
- Finizio, A; Mackay, D; Bidleman, T; Harner, T. (1997). Octanol-air partition coefficient as a predictor of partitioning of semi-volatile organic chemicals to aerosols. *Atmos Environ* 31: 2289-2296.
- Finken, MJ; van Eijsden, M; Loomans, EM; Vrijkotte, TG; Rotteveel, J. (2013). Maternal hypothyroxinemia in early pregnancy predicts reduced performance in reaction time tests in 5- to 6-year-old offspring. *J Clin Endocrinol Metab* 98: 1417-1426. <http://dx.doi.org/10.1210/jc.2012-3389>.
- Fisher, DA; Nelson, JC. (2012). Application of TSH and free thyroxine measurements to thyroid diagnosis: Laboratory support of diagnosis and management. Fisher, DA; Nelson, JC. http://www.questdiagnostics.com/testcenter/testguide.action?dc=WP_AppTSH.
- Flame Control Coatings. (2018). Notes of telephone conversation with Paul Pisarski of Flame Control Coatings and Sue Slotnick of EPA, 6-29-18. <https://www.regulations.gov/document?D=EPA-HQ-OPPT-2016-0735-0111>
- Foekema, EM; Lopez Parron, M; Mergia, MT; Carolus, ER; Vd Berg, JH; Kwadijk, C; Dao, Q; Murk, AJ. (2014). Internal effect concentrations of organic substances for early life development of egg-exposed fish. *Ecotoxicol Environ Saf* 101: 14-22. <http://dx.doi.org/10.1016/j.ecoenv.2013.12.006>.
- Forhead, AJ; Fowden, AL. (2014). Thyroid hormones in fetal growth and prepartum maturation [Review]. *J Endocrinol* 221: R87-R103. <http://dx.doi.org/10.1530/JOE-14-0025>.
- Frasch, HF; Dotson, GS; Bunge, AL; Chen, C; Cherrie, JW; Kasting, GB; Kissel, JC; Sahmel, J; Semple, S; Wilkinson, S. (2014). Analysis of finite dose dermal absorption data: Implications for dermal exposure assessment. *J Expo Sci Environ Epidemiol* 24: 65-73. <http://dx.doi.org/10.1038/jes.2013.23>.
- Fromme, H; Becher, G; Hilger, B; Völkel, W. (2015). Brominated flame retardants - Exposure and risk assessment for the general population [Review]. *Int J Hyg Environ Health* 219: 1-23. <http://dx.doi.org/10.1016/j.ijheh.2015.08.004>.
- Fromme, H; Hilger, B; Kopp, E; Miserok, M; Völkel, W. (2014). Polybrominated diphenyl ethers (PBDEs), hexabromocyclododecane (HBCD) and "novel" brominated flame retardants in house dust in Germany. *Environ Int* 64: 61-68. <http://dx.doi.org/10.1016/j.envint.2013.11.017>.
- FSA. (2006). Brominated chemicals: UK dietary estimates. <https://web.archive.org/web/20120403220652/https://www.food.gov.uk/multimedia/pdfs/fsis1006.pdf>.

- Gavilan-Garcia, I; Elvira, SS; Arturo, GG; Erik, BM; Gonzalez-Gonzalez, LA. (2017). Brominated Flame Retardants (BFRs) analysis in leachates and sludge from a landfill and wastewater plant in the metropolitan area of Mexico City. *J Environ Anal Toxicol* 7: 2161-0525.
- Genskow, KR; Bradner, JM; Hossain, MM; Richardson, JR; Caudle, WM. (2015). Selective damage to dopaminergic transporters following exposure to the brominated flame retardant, HBCDD. *Neurotoxicol Teratol* 52: 162-169. <http://dx.doi.org/10.1016/j.ntt.2015.06.003>.
- Gerecke, AC; Giger, W; Hartmann, PC; Heeb, NV; Kohler, HP; Schmid, P; Zennegg, M; Kohler, M. (2006). Anaerobic degradation of brominated flame retardants in sewage sludge. *Chemosphere* 64: 311-317. <http://dx.doi.org/10.1016/j.chemosphere.2005.12.016>.
- Germer, S; Piersma, AH; van der Ven, L; Kamyschnikow, A; Fery, Y; Schmitz, HJ; Schrenk, D. (2006). Subacute effects of the brominated flame retardants hexabromocyclododecane and tetrabromobisphenol A on hepatic cytochrome P450 levels in rats. *Toxicology* 218: 229-236. <http://dx.doi.org/10.1016/j.tox.2005.10.019>.
- Geyer, HJ; Schramm, K, -W; Darnerud, PO; Aune, M; Feicht, EA; Fried, KW; Henkelmann, B; Lenoir, D; Schmid, P; McDonald, TA. (2004). Terminal elimination half-lives of the brominated flame retardants TBBPA, HBCD, and lower brominated PBDEs in humans. *Organohalogen Compd* 66: 3820-3825.
- Gilbert, ME. (2011). Impact of low-level thyroid hormone disruption induced by propylthiouracil on brain development and function. *Toxicol Sci* 124: 432-445. <http://dx.doi.org/10.1093/toxsci/kfr244>.
- Gilbert, ME; Hedge, JM; Valentin-Blasini, L; Blount, BC; Kannan, K; Tietge, J; Zoeller, RT; Crofton, KM; Jarrett, JM; Fisher, JW. (2013). An animal model of marginal iodine deficiency during development: The thyroid axis and neurodevelopmental outcome. *Toxicol Sci* 132: 177-195. <http://dx.doi.org/10.1093/toxsci/kfs335>.
- Gilbert, ME; Ramos, RL; McCloskey, DP; Goodman, JH. (2014). Subcortical band heterotopia in rat offspring following maternal hypothyroxinaemia: Structural and functional characteristics. *J Neuroendocrinol* 26: 528-541. <http://dx.doi.org/10.1111/jne.12169>.
- Gilbert, ME; Rovet, J; Chen, Z; Koibuchi, N. (2012). Developmental thyroid hormone disruption: prevalence, environmental contaminants and neurodevelopmental consequences. *Neurotoxicology* 33: 842-852. <http://dx.doi.org/10.1016/j.neuro.2011.11.005>.
- Gilbert, ME; Zoeller, RT. (2010). Thyroid hormones--impact on the developing brain: Possible mechanisms of neurotoxicity. In GJ Harry; HA Tilson (Eds.), *Target Organ Toxicology Series*, vol 28 (3rd ed., pp. 79-111). New York, NY: Informa Healthcare.
- Gilbert, ME; Sanchez-Huerta, K; Wood, C. (2016). Mild thyroid hormone insufficiency during development compromises activity-dependent neuroplasticity in the hippocampus of adult male rats. *Endocrinology* 157: 774-787. <http://dx.doi.org/10.1210/en.2015-1643>.
- Glynn, A; Lignell, S; Darnerud, PO; Aune, M; Halldin Ankarberg, E; Bergdahl, IA; Barregård, L; Bensryd, I. (2011). Regional differences in levels of chlorinated and brominated pollutants in mother's milk from primiparous women in Sweden. *Environ Int* 37: 71-79. <http://dx.doi.org/10.1016/j.envint.2010.07.003>.
- Gochfeld, M; Burger, J. (2011). Disproportionate exposures in environmental justice and other populations: the importance of outliers. *Am J Public Health* 101 Suppl 1: S53-S63. <http://dx.doi.org/10.2105/AJPH.2011.300121>.
- Great Lakes Chemical, C. (2003). Material safety data sheet (MSDS): great lakes CD-75P. West Lafayette, Indiana.
- Greene, MA. (2002). *Mouthing times for children from the observational study*. Bethesda, MD: U.S. Consumer Product Safety Commission.
- GSRI. (1978). Mutagenicity test of GLS-S6-41A (not published). (TSCATS/443581. OTS0000947. EPA/OTS Doc #FYI-OTS-0794-0947).

- GSRI. (1994). Initial submission: Letter from Ethyl Corp to USEPA re technical and toxicity data on brominated flame retardants including hexabromocyclododecane, * w/attchmts, dated 5/23/88 [TSCA Submission]. (FYIOTS07940947). Baton Rouge, LA: Ethyl Corporation. <https://ntrl.ntis.gov/NTRL/dashboard/searchResults.xhtml?searchQuery=OTS0000947>.
- Guerra, P; Alae, M; Jiménez, B; Pácepavicius, G; Marvin, C; Macinnis, G; Eljarrat, E; Barceló, D; Champoux, L; Fernie, K. (2012). Emerging and historical brominated flame retardants in peregrine falcon (*Falco peregrinus*) eggs from Canada and Spain. *Environ Int* 40: 179-186. <http://dx.doi.org/10.1016/j.envint.2011.07.014>.
- Guerra, P; De La Cal, A; Marsh, G; Eljarrat, E; Barcelo, D. (2009). Transfer of hexabromocyclododecane from industrial effluents to sediments and biota: Case study in Cinca River (Spain). *J Hydrol* 369: 360-367. <http://dx.doi.org/10.1016/j.jhydrol.2009.02.024>.
- Guerra, P; Eljarrat, E; Barceló, D. (2010). Simultaneous determination of hexabromocyclododecane, tetrabromobisphenol A, and related compounds in sewage sludge and sediment samples from Ebro River basin (Spain). *Anal Bioanal Chem* 397: 2817-2824. <http://dx.doi.org/10.1007/s00216-010-3670-3>.
- Guo, Z. (2002). Review of indoor emission source models Part 2 Parameter estimation [Review]. *Environ Pollut* 120: 551-564.
- Guo, Z. (2013). A Framework for Modelling Non-Steady-State Concentrations of Semivolatile Organic Compounds Indoors - I: Emissions from Diffusional Sources and Sorption by Interior Surfaces. *Indoor Built Environ* 22: 685-700. <http://dx.doi.org/10.1177/1420326X13488123>.
- Hachisuka, A; Nakamura, R; Sato, Y; Nakamura, R; Shibutani, M; Teshima, R. (2010). Effects of perinatal exposure to the brominated flame-retardant hexabromocyclododecane (HBCD) on the developing immune system in rats [translation]. *Kokuritsu Iyakuhin Shokuhin Eisei Kenkyūjo Hōkoku* (128): 58-64.
- Haddow, JE; Palomaki, GE; Allan, WC; Williams, JR; Knight, GJ; Gagnon, J; O'Heir, CE; Mitchell, ML; Hermos, RJ; Waisbren, SE; Faix, JD; Klein, RZ. (1999). Maternal thyroid deficiency during pregnancy and subsequent neuropsychological development of the child. *N Engl J Med* 341: 549-555. <http://dx.doi.org/10.1056/NEJM199908193410801>.
- Hakk, H. (2016). Comparative Metabolism Studies of Hexabromocyclododecane (HBCD) Diastereomers in Male Rats Following a Single Oral Dose. *Environ Sci Technol* 50: 89-96. <http://dx.doi.org/10.1021/acs.est.5b04510>.
- Hakk, H; Szabo, DT; Huwe, J; Diliberto, J; Birnbaum, LS. (2012). Novel and distinct metabolites identified following a single oral dose of α - or γ -hexabromocyclododecane in mice. *Environ Sci Technol* 46: 13494-13503. <http://dx.doi.org/10.1021/es303209g>.
- Hamers, T; Kamstra, JH; Sonneveld, E; Murk, AJ; Kester, MH; Andersson, PL; Legler, J; Brouwer, A. (2006). In vitro profiling of the endocrine-disrupting potency of brominated flame retardants. *Toxicol Sci* 92: 157-173. <http://dx.doi.org/10.1093/toxsci/kfj187>.
- Harrad, S; Abdallah, MA. (2011). Brominated flame retardants in dust from UK cars--within-vehicle spatial variability, evidence for degradation and exposure implications. *Chemosphere* 82: 1240-1245. <http://dx.doi.org/10.1016/j.chemosphere.2010.12.038>.
- Harrad, S; Abdallah, MA. (2015). Concentrations of polybrominated diphenyl ethers, hexabromocyclododecanes and tetrabromobisphenol-A in breast milk from United Kingdom women do not decrease over twelve months of lactation. *Environ Sci Technol* 49: 13899-13903. <http://dx.doi.org/10.1021/acs.est.5b00539>.
- Harrad, S; Goosey, E; Desborough, J; Abdallah, MA; Roosens, L; Covaci, A. (2010). Dust from U.K. primary school classrooms and daycare centers: the significance of dust as a pathway of exposure of young U.K. children to brominated flame retardants and polychlorinated biphenyls. *Environ Sci Technol* 44: 4198-4202. <http://dx.doi.org/10.1021/es100750s>.

- Harrad, S; Abdallah, MA; Rose, NL; Turner, SD; Davidson, TA. (2009). Current-use brominated flame retardants in water, sediment, and fish from English lakes. *Environ Sci Technol* 43: 9077-9083. <http://dx.doi.org/10.1021/es902185u>.
- Hattis, D; Goble, R; Russ, A; Chu, M; Ericson, J. (2004). Age-related differences in susceptibility to carcinogenesis: A quantitative analysis of empirical animal bioassay data. *Environ Health Perspect* 112: 1152-1158. <http://dx.doi.org/10.1289/ehp.6871>.
- Haukås, M; Hylland, K; Berge, JA; Nygård, T; Mariussen, E. (2009). Spatial diastereomer patterns of hexabromocyclododecane (HBCD) in a Norwegian fjord. *Sci Total Environ* 407: 5907-5913. <http://dx.doi.org/10.1016/j.scitotenv.2009.08.024>.
- Haukås, M; Hylland, K; Nygård, T; Berge, JA; Mariussen, E. (2010a). Diastereomer-specific bioaccumulation of hexabromocyclododecane (HBCD) in a coastal food web, Western Norway. *Sci Total Environ* 408: 5910-5916. <http://dx.doi.org/10.1016/j.scitotenv.2010.08.026>.
- Haukås, M; Ruus, A; Hylland, K; Berge, JA; Mariussen, E. (2010b). Bioavailability of hexabromocyclododecane to the polychaete *Hediste diversicolor*: exposure through sediment and food from a contaminated fjord. *Environ Toxicol Chem* 29: 1709-1715. <http://dx.doi.org/10.1002/etc.201>.
- He, MJ; Luo, XJ; Yu, LH; Wu, JP; Chen, SJ; Mai, BX. (2013). Diastereoisomer and enantiomer-specific profiles of hexabromocyclododecane and tetrabromobisphenol A in an aquatic environment in a highly industrialized area, South China: vertical profile, phase partition, and bioaccumulation. *Environ Pollut* 179: 105-110. <http://dx.doi.org/10.1016/j.envpol.2013.04.016>.
- Hedge, JM; Devito, MJ; Crofton, KM. (2009). In vivo acute exposure to polychlorinated biphenyls: effects on free and total thyroxine in rats. *Int J Toxicol* 28: 382-391. <http://dx.doi.org/10.1177/1091581809344631>.
- Heindel, JJ. (1998). Oocyte quantitation and ovarian histology. In *An evaluation and interpretation of reproductive endpoints for human health risk assessment*. Washington, DC: ILSI Press.
- Helleday, T; Tuominen, KL; Bergman, A; Jenssen, D. (1999). Brominated flame retardants induce intragenic recombination in mammalian cells. *Mutat Res* 439: 137-147. [http://dx.doi.org/10.1016/S1383-5718\(98\)00186-7](http://dx.doi.org/10.1016/S1383-5718(98)00186-7).
- Henkel, C. (2016). Safety data sheet (SDS): LF721 medium bulk. Bien Hoa City, Vietnam: Henkel Corporation. <http://mysds.henkel.com/mysds/Search.do?BUSAREA=0006&DOCTYPE=MSDS&COUNTRY=VN&LANG=VI&MATNR=1391002>.
- Henrichs, J; Bongers-Schokking, JJ; Schenk, JJ; Ghassabian, A; Schmidt, HG; Visser, TJ; Hooijkaas, H; de Muinck Keizer-Schrama, SM; Hofman, A; Jaddoe, VV; Visser, W; Steegers, EA; Verhulst, FC; de Rijke, YB; Tiemeier, H. (2010). Maternal thyroid function during early pregnancy and cognitive functioning in early childhood: The generation R study. *J Clin Endocrinol Metab* 95: 4227-4234. <http://dx.doi.org/10.1210/jc.2010-0415>.
- Hinkson, NC; Whalen, MM. (2009). Hexabromocyclododecane decreases the lytic function and ATP levels of human natural killer cells. *J Appl Toxicol* 29: 656-661. <http://dx.doi.org/10.1002/jat.1453>.
- Hinkson, NC; Whalen, MM. (2010). Hexabromocyclododecane decreases tumor-cell-binding capacity and cell-surface protein expression of human natural killer cells. *J Appl Toxicol* 30: 302-309. <http://dx.doi.org/10.1002/jat.1495>.
- Hloušková, V; Lanková, D; Kalachová, K; Hrádková, P; Poustka, J; Hajšlová, J; Pulkrabová, J. (2013). Occurrence of brominated flame retardants and perfluoroalkyl substances in fish from the Czech aquatic ecosystem. *Sci Total Environ* 461-462: 88-98. <http://dx.doi.org/10.1016/j.scitotenv.2013.04.081>.
- Hoh, E; Hites, RA. (2005). Brominated flame retardants in the atmosphere of the East-Central United States. *Environ Sci Technol* 39: 7794-7802. <http://dx.doi.org/10.1021/es050718k>.

- [Hong, H; Li, D; Shen, R; Wang, X; Shi, D.](#) (2014). Mechanisms of hexabromocyclododecanes induced developmental toxicity in marine medaka (*Oryzias melastigma*) embryos. *Aquat Toxicol* 152: 173-185. <http://dx.doi.org/10.1016/j.aquatox.2014.04.010>.
- [Hong, H; Shen, R; Liu, W; Li, D; Huang, L; Shi, D.](#) (2015). Developmental toxicity of three hexabromocyclododecane diastereoisomers in embryos of the marine medaka *Oryzias melastigma*. *Mar Pollut Bull* 101: 110-118. <http://dx.doi.org/10.1016/j.marpolbul.2015.11.009>.
- [Horn, GP; Kerber, S; Fent, KW; Fernhall, B; Smith, DL.](#) (2016). Interim Report: Cardiovascular & Chemical Exposure Risks in Modern Firefighting. (EMW-2013-FP-00766). Urbana-Champaign, IL: Illinois Fire Service Institute, University of Illinois at Urbana-Champaign. https://www.fsi.illinois.edu/documents/research/CardioChemRisksModernFF_InterimReport2016.pdf
- [Howdeshell, KL.](#) (2002). A model of the development of the brain as a construct of the thyroid system [Review]. *Environ Health Perspect* 110 Suppl 3: 337-348. <http://dx.doi.org/10.1289/ehp.02110s3337>.
- [HSDB.](#) (2008). Hexabromocyclododecane (HBCD) [Database]. Bethesda, MD: National Library of Medicine. Retrieved from <http://toxnet.nlm.nih.gov/cgi-bin/sis/search/f?./temp/~XQzOHy:1>
- [Hu, J; Liang, Y; Chen, M; Wang, X.](#) (2009a). Assessing the toxicity of TBBPA and HBCD by zebrafish embryo toxicity assay and biomarker analysis. *Environ Toxicol* 24: 334-342. <http://dx.doi.org/10.1002/tox.20436>.
- [Hu, X; Hu, D; Xu, Y.](#) (2009b). Effects of tetrabrominated diphenyl ether and hexabromocyclododecanes in single and complex exposure to hepatoma HepG2 cells. *Environ Toxicol Pharmacol* 27: 327-337. <http://dx.doi.org/10.1016/j.etap.2008.11.014>.
- [Huang, L; Fantke, P; Ernstoff, A; Jolliet, OA.](#) (2017). Quantitative Property-Property Relationship for the Internal Diffusion Coefficients of Organic Compounds in Solid Materials. *Indoor Air* 27: 1128-1140.
- [HUD.](#) (2016). American housing survey, components of inventory change: 2011–2013. <https://www.huduser.gov/portal/datasets/cinch/cinch13/cinch11-13.pdf>.
- [Hulbert, AJ.](#) (2000). Thyroid hormones and their effects: a new perspective [Review]. *Biol Rev Camb Philos Soc* 75: 519-631.
- [Huntingdon Research Center.](#) (1990). Ames metabolic activation test to assess the potential mutagenic effect of und no. 49 with cover letter dated 031290 [TSCA Submission]. (TSCATS/406642. OTS0522948. 86900000385). Wyandotte, MI: BASF Corporation. <https://ntrl.ntis.gov/NTRL/dashboard/searchResults.xhtml?searchQuery=OTS0522948>.
- [IBT Labs.](#) (1990). Mutagenicity of two lots of FM-100 lot 53 and residue of lot 3322 in the absence and presence of metabolic activation with test data and cover letter [TSCA Submission]. In Epa/Ots (pp. #86-900000267). (TSCATS/407259. OTS0523259. Doc I.D. 86900000267). West Lafayette, IN: Great Lakes Chemical Corporation. <https://ntrl.ntis.gov/NTRL/dashboard/searchResults.xhtml?searchQuery=OTS0523259>.
- [Ichihara, M; Yamamoto, A; Takakura, K; Kakutani, N; Sudo, M.](#) (2014). Distribution and pollutant load of hexabromocyclododecane (HBCD) in sewage treatment plants and water from Japanese Rivers. *Chemosphere* 110: 78-84. <http://dx.doi.org/10.1016/j.chemosphere.2014.03.074>.
- [Ilyina, T; Hunziker, RW.](#) (2010). Scenarios of temporal and spatial evolution of hexabromocyclododecane in the North Sea. *Environ Sci Technol* 44: 4622-4628. <http://dx.doi.org/10.1021/es9034599>.
- [Indium, C.](#) (2018a). Follow-up questions about Indium's use of HBCD-Email exchange with Indium Corporation and Sue Slotnick in September 2018 [Personal Communication].
- [Indium, C.](#) (2018b). Use of HBCD in manufacture of solder paste by Indium Corporation-Phone call with Sue Slotnick [Personal Communication].

- Indium Corporation. (2019a). Application Notes: Soldering 101- A Basic Overview. Indium Corporation. <https://www.indium.com/technical-documents/application-notes/>.
- Indium Corporation. (2019b). Product Data Sheets: TACFlux 483. Indium Corporation. <https://www.indium.com/technical-documents/product-data-sheets/>.
- INEOS Styrenics. (2017). Analysis of alternatives: HBCDD use in EPS for building applications. Helsinki, Finland: European Chemicals Agency. <https://echa.europa.eu/documents/10162/5164baf4-1f50-45a5-97e2-1c9c7597a692>.
- Insulfoam a Division of Carlisle Construction, M. (2015). Safety data sheet (SDS): 085 insulfoam molded EPS products. Puyallup, WA: Insulfoam a Division of Carlisle Construction Materials. https://www.insulfoam.com/wp-content/uploads/2014/04/MSDS_Aug-2015.pdf.
- IRDC. (1978a). Acute inhalation toxicity study in rats with hexabromocyclododecane with attachments and cover letter dated 042478 [TSCA Submission]. (EPA/OTS Doc #88-7800137; 8EHQ04780137). Chicago, IL: Velsicol Chemical Corporation. <https://ntrl.ntis.gov/NTRL/dashboard/searchResults.xhtml?searchQuery=OTS0200488>.
- IRDC. (1978b). Acute toxicity studies in rabbits and rats with hexabromocyclododecane with attachments [TSCA Submission]. (EPA/OTS Doc #88-7800065; 8EHQ02780065). Chicago, IL: Velsicol Chemical Corporation. <https://ntrl.ntis.gov/NTRL/dashboard/searchResults.xhtml?searchQuery=OTS0200051>.
- IRDC. (1978c). Acute toxicity studies in rabbits and rats with residue of hexabromocyclododecane with attachments and cover letter dated 030178 [TSCA Submission]. (88-7800088; 8EHQ03780088). Chicago, IL: Velsicol Chemical Corporation. <https://ntrl.ntis.gov/NTRL/dashboard/searchResults.xhtml?searchQuery=OTS0200466>.
- Jacobs, K. (2019). [Personal communication with Keith Jacobs, EPA containing individual animal data on physical development for Ema et al, 2008] [Personal Communication].
- Jang, M; Shim, WJ; Han, GM; Rani, M; Song, YK; Hong, SH. (2016). Styrofoam Debris as a Source of Hazardous Additives for Marine Organisms. *Environ Sci Technol* 50: 4951-4960. <http://dx.doi.org/10.1021/acs.est.5b05485>
- Jang, M; Shim, WJ; Han, GM; Rani, M; Song, YK; Hong, SH. (2017). Widespread detection of a brominated flame retardant, hexabromocyclododecane, in expanded polystyrene marine debris and microplastics from South Korea and the Asia-Pacific coastal region. *Environ Pollut* 231: 785-794. <http://dx.doi.org/10.1016/j.envpol.2017.08.066>
- Jeong, GH; Hwang, NR; Hwang, EH; Lee, BC; Yoon, J. (2014). Hexabromocyclododecanes in crucian carp and sediment from the major rivers in Korea. *Sci Total Environ* 470-471: 1471-1478. <http://dx.doi.org/10.1016/j.scitotenv.2013.10.038>.
- Johnson, PI; Stapleton, HM; Mukherjee, B; Hauser, R; Meeker, JD. (2013). Associations between brominated flame retardants in house dust and hormone levels in men. *Sci Total Environ* 445-446: 177-184. <http://dx.doi.org/10.1016/j.scitotenv.2012.12.017>.
- Julvez, J; Alvarez-Pedrerol, M, ar; Rebagliato, M; Murcia, M; Fornes, J; Garcia-Esteban, R; Lertxundi, N; Espada, M; Tardon, A; Riano Galan, I; Sunyer, J. (2013). Thyroxine levels during pregnancy in healthy women and early child neurodevelopment. *Epidemiology* 24: 150-157. <http://dx.doi.org/10.1097/EDE.0b013e318276ccd3>.
- Kajiwara, N; Hirata, O; Takigami, H; Noma, Y; Tachifuji, A; Matsufuji, Y. (2014). Leaching of brominated flame retardants from mixed wastes in lysimeters under conditions simulating landfills in developing countries. *Chemosphere* 116: 46-53. <http://dx.doi.org/10.1016/j.chemosphere.2014.01.025>.
- Kakimoto, K; Akutsu, K; Konishi, Y; Tanaka, Y. (2008). Time trend of hexabromocyclododecane in the breast milk of Japanese women. *Chemosphere* 71: 1110-1114. <http://dx.doi.org/10.1016/j.chemosphere.2007.10.035>.

- Kakimoto, K; Nagayoshi, H; Yoshida, J; Akutsu, K; Konishi, Y; Toriba, A; Hayakawa, K. (2012). Detection of Dechlorane Plus and brominated flame retardants in marketed fish in Japan. *Chemosphere* 89: 416-419. <http://dx.doi.org/10.1016/j.chemosphere.2012.05.072>.
- Kataoka, T; Kuribara, I; Katagiri, R; Wada, T; Masunaga, S. (2012). Emission Rates of Hexabromocyclododecane (HBCD) from the Surface of Building Materials. Japan: Chemicals Evaluation and Research Institute Japan, Yokohama National University, Graduate School of Environment and Information Sciences.
- Kato, Y; Ikushiro, S; Emi, Y; Tamaki, S; Suzuki, H; Sakaki, T; Yamada, S; Degawa, M. (2008). Hepatic UDP-glucuronosyltransferases responsible for glucuronidation of thyroxine in humans. *Drug Metab Dispos* 36: 51-55. <http://dx.doi.org/10.1124/dmd.107.018184>.
- Kavlock, RJ; Allen, BC; Faustman, EM; Kimmel, CA. (1995). Dose-response assessments for developmental toxicity .4. Benchmark doses for fetal weight changes. *Toxicol Sci* 26: 211-222. <http://dx.doi.org/10.1006/faat.1995.1092>.
- Kelly, GS. (2000). Peripheral metabolism of thyroid hormones: a review [Review]. *Altern Med Rev* 5: 306-333.
- KemI. (2009). Proposal for harmonised classification and labelling: Substance name: Hexabromocyclododecane. Helsinki, Finland: European Chemicals Agency. <https://echa.europa.eu/documents/10162/8284634d-8fa9-43ad-aaaa-f449dc28ff8c>.
- Kester. (2018). Email exchange between Kester and EPA, August 2018 re use of HBCD [Personal Communication].
- Kester, I. (2015). Safety data sheet (SDS): EP256HA solder paste. Itasca, IL: Kester Inc. <http://www.techni-tool.com/site/MSDS/488SO2566.pdf>.
- Kiciński, M; Viaene, MK; Den Hond, E; Schoeters, G; Covaci, A; Dirtu, AC; Nelen, V; Bruckers, L; Croes, K; Sioen, I; Baeyens, W; Van Larebeke, N; Nawrot, TS. (2012). Neurobehavioral function and low-level exposure to brominated flame retardants in adolescents: A cross-sectional study. *Environ Health* 11: 86. <http://dx.doi.org/10.1186/1476-069X-11-86>.
- Kim, UJ; Oh, JE. (2014). Tetrabromobisphenol A and hexabromocyclododecane flame retardants in infant-mother paired serum samples, and their relationships with thyroid hormones and environmental factors. *Environ Pollut* 184: 193-200. <http://dx.doi.org/10.1016/j.envpol.2013.08.034>.
- Kissel, JC. (2011). The mismeasure of dermal absorption. *J Expo Sci Environ Epidemiol* 21: 302-309. <http://dx.doi.org/10.1038/jes.2010.22>.
- Kitto, JBStSC. (1992). Steam: Its Generation and Use. In JBSSC Kitto (Ed.), (40th ed.). Barberton, Ohio: The Babcock & Wilcox Company.
- Klaassen, CD; Hood, AM. (2001). Effects of microsomal enzyme inducers on thyroid follicular cell proliferation and thyroid hormone metabolism [Review]. *Toxicol Pathol* 29: 34-40. <http://dx.doi.org/10.1080/019262301301418838>.
- KLIF. (2010). New organic pollutants in air, 2007. Brominated flame retardants and polyfluorinated substances. In Norwegian Institute for Air Research (NILU) (pp. 61). (SPFO-report 1077/2010, TA-2689/2010). Norway: Climate and Pollution Agency. <http://www.miljodirektoratet.no/old/klif/publikasjoner/2689/ta2689.pdf>.
- Klosterhaus, SL; Stapleton, HM; La Guardia, MJ; Greig, DJ. (2012). Brominated and chlorinated flame retardants in San Francisco Bay sediments and wildlife. *Environ Int* 47: 56-65. <http://dx.doi.org/10.1016/j.envint.2012.06.005>.
- Kobiliris, D. (2010). Influence of embryonic exposure to hexabromocyclododecane (HBCD) on the corticosterone response and “fight or flight” behaviors of captive American kestrels (pp. 1-58). Montreal, Canada: Kobiliris, D. http://digitool.library.mcgill.ca/webclient/StreamGate?folder_id=0&dvs=1488987858161~447.

- [Koelmans, AA; Bakir, A; Burton, GA; Janssen, CR.](#) (2016). Microplastic as a Vector for Chemicals in the Aquatic Environment: Critical Review and Model-Supported Reinterpretation of Empirical Studies [Review]. *Environ Sci Technol* 50: 3315-3326. <http://dx.doi.org/10.1021/acs.est.5b06069>
- [Kohler, M; Zennegg, M; Bogdal, C; Gerecke, AC; Schmid, P; Heeb, NV; Sturm, M; Vonmont, H; Kohler, HP; Giger, W.](#) (2008). Temporal trends, congener patterns, and sources of octa-, nona-, and decabromodiphenyl ethers (PBDE) and hexabromocyclododecanes (HBCD) in Swiss lake sediments. *Environ Sci Technol* 42: 6378-6384. <http://dx.doi.org/10.1021/es702586r>.
- [Koibuchi, N; Chin, MW.](#) (2000). Thyroid hormone action and brain development. *Trends Endocrinol Metab* 11: 123-128. [http://dx.doi.org/10.1016/S1043-2760\(00\)00238-1](http://dx.doi.org/10.1016/S1043-2760(00)00238-1).
- [Koike, E; Yanagisawa, R; Takano, H.](#) (2016). Brominated flame retardants, hexabromocyclododecane and tetrabromobisphenol A, affect proinflammatory protein expression in human bronchial epithelial cells via disruption of intracellular signaling. *Toxicol In Vitro* 32: 212-219. <http://dx.doi.org/10.1016/j.tiv.2015.12.013>.
- [Kowalski, B; Mazur, M.](#) (2014). The Simultaneous Determination of Six Flame Retardants in Water Samples Using SPE Pre-concentration and UHPLC-UV Method. *Water Air Soil Pollut* 225: 1866. <http://dx.doi.org/10.1007/s11270-014-1866-4>
- [Kuang, J; Ma, Y; Harrad, S.](#) (2016). Concentrations of "legacy" and novel brominated flame retardants in matched samples of UK kitchen and living room/bedroom dust. *Chemosphere* 149: 224-230. <http://dx.doi.org/10.1016/j.chemosphere.2016.01.092>.
- [Kuiper, RV; Cantón, RF; Leonards, PE; Jenssen, BM; Dubbeldam, M; Wester, PW; van den Berg, M; Vos, JG; Vethaak, AD.](#) (2007). Long-term exposure of European flounder (*Platichthys flesus*) to the flame-retardants tetrabromobisphenol A (TBBPA) and hexabromocyclododecane (HBCD). *Ecotoxicol Environ Saf* 67: 349-360. <http://dx.doi.org/10.1016/j.ecoenv.2006.12.001>.
- [Kurokawa, Y; Inoue, T; Uchida, Y; Momma, J.](#) (1984). Carcinogenesis test of flame retarder hexabromocyclododecane in mice (Summary, unpublished, translated into English). Department of Toxicology, National Public Health Research Institute, Biological Safety Test and Research Centre.
- [La Guardia, MJ; Hale, RC; Harvey, E; Chen, D.](#) (2010). Flame-retardants and other organohalogenes detected in sewage sludge by electron capture negative ion mass spectrometry. *Environ Sci Technol* 44: 4658-4664. <http://dx.doi.org/10.1021/es9039264>.
- [La Guardia, MJ; Hale, RC; Harvey, E; Mainor, TM; Ciparis, S.](#) (2012). In situ accumulation of HBCD, PBDEs, and several alternative flame-retardants in the bivalve (*Corbicula fluminea*) and gastropod (*Elimia proxima*). *Environ Sci Technol* 46: 5798-5805. <http://dx.doi.org/10.1021/es3004238>.
- [Lambert, S; Sinclair, C; Boxall, A.](#) (2014). Occurrence, Degradation, and Effect of Polymer-Based Materials in the Environment. *Rev Environ Contam Toxicol* 227: 1-53. http://dx.doi.org/10.1007/978-3-319-01327-5_1
- [Lansink, CJM; Breelen, MSC; Marquart, J; van Hemmen, JJ.](#) (1996). Skin exposure to calcium carbonate in the paint industry. Preliminary modelling of skin exposure levels to powders based on field data. (V96.064). Rijswijk, The Netherlands: TNO Nutrition and Food Research Institute.
- [LANXESS.](#) (2017a). Personal communication between Richard Henrich, LANXESS Solutions US, Inc. (formerly Chemtura Corporation), and Timothy Lehman, EPA, regarding Hexabromocyclododecane (HBCD).
- [Lavers, JL; Bond, AL; Hutton, Ia.](#) (2014). Plastic ingestion by Flesh-footed Shearwaters (*Puffinus carneipes*): Implications for fledgling body condition and the accumulation of plastic-derived chemicals. *Environ Pollut* 187: 124-129. <http://dx.doi.org/10.1016/j.envpol.2013.12.020>
- [Law, K; Halldorson, T; Danell, R; Stern, G; Gewurtz, S; Alaei, M; Marvin, C; Whittle, M; Tomy, G.](#) (2006). Bioaccumulation and trophic transfer of some brominated flame retardants in a Lake

- Winnipeg (Canada) food web. *Environ Toxicol Chem* 25: 2177-2186.
<http://dx.doi.org/10.1897/05-500R.1>
- Law, K; Palace, VP; Halldorson, T; Danell, R; Wautier, K; Evans, B; Alae, M; Marvin, C; Tomy, GT. (2006). Dietary accumulation of hexabromocyclododecane diastereoisomers in juvenile rainbow trout (*Oncorhynchus mykiss*). I: Bioaccumulation parameters and evidence of bioisomerization. *Environ Toxicol Chem* 25: 1757. <http://dx.doi.org/10.1897/05-445r.1>.
- Law, R, obin J.; Allchin, C, olin R.; de Boer, J, acob; Covaci, A, drian; Herzke, D, orte; Lepom, P, eter; Morri, S, teven; Tronczynski, J, acek; de Wit, C, ynthia A. (2006). Levels and trends of brominated flame retardants in the European environment. *Chemosphere* 64.
<http://dx.doi.org/10.1016/j.chemosphere.2005.12.007>.
- Lee, CC; Chang, WH; Chen, HL. (2019). Dietary exposure and risk assessment of exposure to hexabromocyclododecanes in a Taiwan population. *Environ Pollut* 249: 728-734.
<http://dx.doi.org/10.1016/j.envpol.2019.03.040>.
- Leisewitz, A; Kruse, H; Schramm, E. (2001). Substituting environmentally relevant flame retardants: Assessment fundamentals. Berlin, Germany: Umweltbundesamt.
<https://www.umweltbundesamt.de/en/publikationen/substituting-environmentally-relevant-flame>
- Leonards, PEG; Santillo, D; Brigden, K; Veen, I; Van Hesseligen, J; De Boer, J; Johnston, P. (2001). Brominated flame retardants in office dust samples. *Proceedings of the Second International Workshop on Brominated Flame Retardants*, 14–16 May 2001 (pp. 1-4). Stockholm, Sweden: Leonards, PEG; Santillo, D; Brigden, K; Veen, I; Van Hesseligen, J; De Boer, J; Johnston, P.
<http://edepot.wur.nl/347535>.
- Letcher, RJ; Gebbink, WA; Sonne, C; Born, EW; Mckinney, MA; Dietz, R. (2009). Bioaccumulation and biotransformation of brominated and chlorinated contaminants and their metabolites in ringed seals (*Pusa hispida*) and polar bears (*Ursus maritimus*) from East Greenland. *Environ Int* 35: 1118-1124. <http://dx.doi.org/10.1016/j.envint.2009.07.006>.
- Lewis, AC; Palanker, AL. (1978a). A dermal LD50 study in albino rabbits and an inhalation LC50 study in albino rats. Test material GLS-S6-41A [unpublished]. (Experiment Reference No. 78385-2). Fairfield, NJ: Consumer Product Testing.
- Lewis, AC; Palanker, AL. (1978b). A primary dermal irritation study, a dermal corrosion study, and an ocular irritation study in albino rabbits and an oral LD50 study in albino rats: Test material GLS-S6-41A. (78385-1). Consumer Product Testing.
- Li, B; Yao, T; Sun, H; Zhang, Y; Yang, J. (2016). Diastereomer- and enantiomer-specific accumulation, depuration, bioisomerization, and metabolism of hexabromocyclododecanes (HBCDs) in two ecologically different species of earthworms. *Sci Total Environ* 542: 427-434.
<http://dx.doi.org/10.1016/j.scitotenv.2015.10.100>.
- Lignell, S; Darnerud, PO; Aune, M; Tömkvist, A. (2003). Persistent organic pollutants (POP) in breastmilk from primiparae women in Uppsala County, Sweden, 2002–2003. In Report to the Swedish Environmental Protection Agency (pp. 10). Lignell, S; Darnerud, PO; Aune, M; Tömkvist, A. <https://www.diva-portal.org/smash/get/diva2:657868/FULLTEXT01.pdf>.
- Lilienthal, H; van der Ven, LT; Piersma, AH; Vos, JG. (2009). Effects of the brominated flame retardant hexabromocyclododecane (HBCD) on dopamine-dependent behavior and brainstem auditory evoked potentials in a one-generation reproduction study in Wistar rats. *Toxicol Lett* 185: 63-72.
<http://dx.doi.org/10.1016/j.toxlet.2008.12.002>.
- Lind, Y; Darnerud, PO; Atuma, S; Aune, M; Becker, W; Bjerselius, R; Cnattingius, S; Glynn, A. (2003). Polybrominated diphenyl ethers in breast milk from Uppsala County, Sweden. *Environ Res* 93: 186-194.
- Lindberg, P; Sellström, U; Häggberg, L; de Wit, CA. (2004). Higher brominated diphenyl ethers and hexabromocyclododecane found in eggs of peregrine falcons (*Falco peregrinus*) breeding in Sweden. *Environ Sci Technol* 38: 93-96. <http://dx.doi.org/10.1021/es034614q>.

- Litton Bionetics. (1990). Mutagenicity evaluation of 421-32B (final report) with test data and cover letter [TSCA Submission]. (TSCATS/407257. OTS0523257. 86900000265). West Lafayette, IN: Great Lakes Chemical Corporation.
<https://ntrl.ntis.gov/NTRL/dashboard/searchResults.xhtml?searchQuery=OTS0523257>.
- Liu, D; Teng, W; Shan, Z; Yu, X; Gao, Y; Wang, S; Fan, C; Wang, H; Zhang, H. (2010). The effect of maternal subclinical hypothyroidism during pregnancy on brain development in rat offspring. *Thyroid* 20: 909-915. <http://dx.doi.org/10.1089/thy.2009.0036>.
- Lohmann, R. (2017). Microplastics are not important for the cycling and bioaccumulation of organic pollutants in the oceans-but should microplastics be considered POPs themselves? *Integr Environ Assess Manag* 13: 460-465. <http://dx.doi.org/10.1002/ieam.1914>
- Lower, N; Moore, A. (2007). The impact of a brominated flame retardant on smoltification and olfactory function in Atlantic salmon (*Salmo salar* L.) smolts. *Mar Behav Physiol* 40: 267-284.
<http://dx.doi.org/10.1080/10236240701592104>.
- Luigi, V; Giuseppe, M; Claudio, R. (2015). Emerging and priority contaminants with endocrine active potentials in sediments and fish from the River Po (Italy). *Environ Sci Pollut Res Int* 22: 14050-14066. <http://dx.doi.org/10.1007/s11356-015-4388-8>.
- Lyons, BP; Barber, JL; Rumney, HS; Bolam, TP; Bersuder, P; Law, RJ; Mason, C; Smith, AJ; Morris, S; Devlin, MJ; Al-Enezi, M; Massoud, MS; Al-Zaidan, AS; Al-Sarawi, HA. (2015). Baseline survey of marine sediments collected from the State of Kuwait: PAHs, PCBs, brominated flame retardants and metal contamination. *Mar Pollut Bull* 100: 629-636.
<http://dx.doi.org/10.1016/j.marpolbul.2015.08.014>.
- Luster, MI; Johnson, VJ; Yucesoy, B; Simeonova, PP. (2005). Biomarkers to assess potential developmental immunotoxicity in children. *Toxicol Appl Pharmacol* 206: 229-236.
<http://dx.doi.org/10.1016/j.taap.2005.02.010>.
- MacGregor, JA; Nixon, WB. (2004). Determination of water solubility of hexabromocyclododecane (HBCD) using a generator column method. (Project No. 439C-138). Easton, MD: Wildlife International Ltd.
- Mackay, D. (1991). Multimedia environmental models: the fugacity approach. Chelsea, MI: Lewis Publishers.
- Makris, S. (2016). [Personal communication with Sue Makris, EPA containing individual animal data for Ema et al, 2008] [Personal Communication].
- Managaki, S; Miyake, Y; Yokoyama, Y; Hondo, H; Masunaga, S; Nakai, S; Kobayashi, T; Kameya, T; Kimura, A; Nakarai, T; Oka, Y; Otani, H; Miyake, A. (2009). Emission Load of Hexabromocyclododecane in Japan Based on the Substance Flow Analysis. *Organohalogen Compd* 71: 2471-2476.
- Maranghi, F; Tassinari, R; Moracci, G; Altieri, I; Rasinger, JD; Carroll, TS; Hogstrand, C; Lundebye, AK; Mantovani, A. (2013). Dietary exposure of juvenile female mice to polyhalogenated seafood contaminants (HBCD, BDE-47, PCB-153, TCDD): comparative assessment of effects in potential target tissues. *Food Chem Toxicol* 56: 443-449.
<http://dx.doi.org/10.1016/j.fct.2013.02.056>.
- Mariussen, E; Fonnum, F. (2003). The effect of brominated flame retardants on neurotransmitter uptake into rat brain synaptosomes and vesicles. *Neurochem Int* 43: 533-542.
[http://dx.doi.org/10.1016/S0197-0186\(03\)00044-5](http://dx.doi.org/10.1016/S0197-0186(03)00044-5).
- Maron, DM; Ames, BN. (1983). Revised methods for salmonella mutagenicity test. *Mutat Res Environ Mutagen Relat Subj* 113: 173-215. [http://dx.doi.org/10.1016/0165-1161\(83\)90010-9](http://dx.doi.org/10.1016/0165-1161(83)90010-9).
- Marquart, H; Warren, ND; Laitinen, J; Van Hemmen, JJ. (2006). Default values for assessment of potential dermal exposure of the hands to industrial chemicals in the scope of regulatory risk assessments. *Ann Occup Hyg* 50: 469-489. <http://dx.doi.org/10.1093/annhyg/mel012>.

- [Marvin, CH; Tomy, GT; Alae, M; Macinnis, G.](#) (2006). Distribution of hexabromocyclododecane in Detroit River suspended sediments. *Chemosphere* 64: 268-275. <http://dx.doi.org/10.1016/j.chemosphere.2005.12.011>.
- [Marteinson, SC; Bird, DM; Letcher, RJ; Sullivan, KM; Ritchie, IJ; Fernie, KJ.](#) (2012). Dietary exposure to technical hexabromocyclododecane (HBCD) alters courtship, incubation and parental behaviors in American kestrels (*Falco sparverius*). *Chemosphere* 89: 1077-1083. <http://dx.doi.org/10.1016/j.chemosphere.2012.05.073>.
- [Marteinson, SC; Bird, DM; Shutt, JL; Letcher, RJ; Ritchie, IJ; Fernie, KJ.](#) (2010). Multi-generational effects of polybrominated diphenylethers exposure: embryonic exposure of male American kestrels (*Falco sparverius*) to DE-71 alters reproductive success and behaviors. *Environ Toxicol Chem* 29: 1740-1747. <http://dx.doi.org/10.1002/etc.200>.
- [Marteinson, SC; Kimmins, S; Letcher, RJ; Palace, VP; Bird, DM; Ritchie, IJ; Fernie, KJ.](#) (2011). Diet exposure to technical hexabromocyclododecane (HBCD) affects testes and circulating testosterone and thyroxine levels in American kestrels (*Falco sparverius*). *Environ Res* 111: 1116-1123. <http://dx.doi.org/10.1016/j.envres.2011.08.006>.
- [Marvin, CH; Tomy, GT; Armitage, JM; Arnot, JA; Mccarty, L; Covaci, A; Palace, V.](#) (2011). Hexabromocyclododecane: current understanding of chemistry, environmental fate and toxicology and implications for global management. *Environ Sci Technol* 45: 8613-8623. <http://dx.doi.org/10.1021/es201548c>.
- [Mayer, AC; Fent, KW; Bertke, S; Horn, GP; Smith, DL; Kerber, S; La Gaurdia, MJ.](#) (2019). Firefighter hood contamination: Efficiency of laundering to remove PAHs and FRs. *J Occup Environ Hyg* 16:2: 129-140. <http://dx.doi.org/https://doi.org/10.1080/15459624.2018.1540877>
- [Meijer, L; Martijn, A; Melessen, J; Brouwer, A; Weiss, J; de Jong, FH; Sauer, PJ.](#) (2012). Influence of prenatal organohalogen levels on infant male sexual development: sex hormone levels, testes volume and penile length. *Hum Reprod* 27: 867-872. <http://dx.doi.org/10.1093/humrep/der426>.
- [Meijer, L; Weiss, J; Van Velzen, M; Brouwer, A; Bergman, A; Sauer, PJ.](#) (2008). Serum concentrations of neutral and phenolic organohalogens in pregnant women and some of their infants in The Netherlands. *Environ Sci Technol* 42: 3428-3433. <http://dx.doi.org/10.1021/es702446p>.
- [Meng, XZ; Xiang, N; Duan, YP; Chen, L; Zeng, EY.](#) (2012). Hexabromocyclododecane in consumer fish from South China: implications for human exposure via dietary intake. *Environ Toxicol Chem* 31: 1424-1430. <http://dx.doi.org/10.1002/etc.1826>.
- [Microbiological Associates.](#) (1996a). Hexabromocyclododecane (HBCD): Chromosome aberrations in human peripheral blood lymphocytes with cover letter dated 12/12/1996 [TSCA Submission]. (TSCATS/453439. OTS0573552. Doc I.D. 86970000358). Arlington, VA: Chemical Manufacturers Association. <https://ntrl.ntis.gov/NTRL/dashboard/searchResults.xhtml?searchQuery=OTS0573552>.
- [Microbiological Associates.](#) (1996b). Hexabromocyclododecane (HBCD): Maximization test in guinea pigs with cover letter dated 12/12/1996 [TSCA Submission]. (86970000356). Arlington, VA: Chemical Manufacturers Association. <https://ntrl.ntis.gov/NTRL/dashboard/searchResults.xhtml?searchQuery=OTS0573550>.
- [Miller-Rhodes, P; Popescu, M; Goeke, C; Tirabassi, T; Johnson, L; Markowski, VP.](#) (2014). Prenatal exposure to the brominated flame retardant hexabromocyclododecane (HBCD) impairs measures of sustained attention and increases age-related morbidity in the Long-Evans rat. *Neurotoxicol Teratol* 45: 34-43. <http://dx.doi.org/10.1016/j.ntt.2014.06.009>.
- [Minh, NH; Isobe, T; Ueno, D; Matsumoto, K; Mine, M; Kajiwara, N; Takahashi, S; Tanabe, S.](#) (2007). Spatial distribution and vertical profile of polybrominated diphenyl ethers and hexabromocyclododecanes in sediment core from Tokyo Bay, Japan. *Environ Pollut* 148: 409-417. <http://dx.doi.org/10.1016/j.envpol.2006.12.011>.

- Minnesota Department of Health. (2016). Flame Retardants and Firefighter Exposure and Health. St. Paul, MN: Minnesota Department of Health, Environmental Surveillance and Assessment Section.
<https://www.health.state.mn.us/communities/environment/risk/docs/studies/retardantreport.pdf>
- Morris, S; Allchin, CR; Zegers, BN; Haftka, JJ; Boon, JP; Belpaire, C; Leonards, PE; Van Leeuwen, SP; De Boer, J. (2004). Distribution and fate of HBCD and TBBPA brominated flame retardants in North Sea estuaries and aquatic food webs. *Environ Sci Technol* 38: 5497-5504.
<http://dx.doi.org/10.1021/es049640i>.
- Mizouchi, S; Ichiba, M; Takigami, H; Kajiwara, N; Takamuku, T; Miyajima, T; Kodama, H; Someya, T; Ueno, D. (2015). Exposure assessment of organophosphorus and organobromine flame retardants via indoor dust from elementary schools and domestic houses. *Chemosphere* 123: 17-25. <http://dx.doi.org/10.1016/j.chemosphere.2014.11.028>.
- MOEJ. (2009). 6-Week Administration Study of 1,2,5,6,9,10-Hexabromocyclododecane for avian reproduction toxicity under long-day conditions using Japanese Quail. Tokyo, Japan: Ministry of the Environment, Japan.
- Momma, J; Kaniwa, M; Sekiguchi, H; Ohno, K; Kawasaki, Y; Tsuda, M; Nakamura, A; Kurokawa, Y. (1993). [Dermatological evaluation of a flame retardant, hexabromocyclododecane (HBCD) on guinea pig by using the primary irritation, sensitization, phototoxicity and photosensitization of skin]. *Eisei Shikenjo Hokoku* 18-24.
- Morf, LS; Tremp, J; Gloor, R; Huber, Y; Stengele, M; Zennegg, M. (2005). Brominated flame retardants in waste electrical and electronic equipment: substance flows in a recycling plant. *Environ Sci Technol* 39: 8691-8699. <http://dx.doi.org/10.1021/es051170k>.
- Morose, G. (2006). An overview of alternatives to tetrabromobisphenol A (TBBPA) and hexabromocyclododecane (HBCD). In Lowell Center for Sustainable Production, University of Massachusetts, Lowell (pp. 1-32). Lowell, MA.: Prepared for the Jennifer Altman Foundation.
<http://www.chemicalspolicy.org/downloads/AlternativestoTBBPAandHBCD.pdf>.
- Moya, J; Phillips, L. (2014). A review of soil and dust ingestion studies for children [Review]. *J Expo Sci Environ Epidemiol* 24: 545-554. <http://dx.doi.org/10.1038/jes.2014.17>.
- Multi-Panels, C. (2015). Material safety data sheet (MSDS): XPS boards. La Jolla, California: Multi-Panels Corporation. <http://www.multi-panels.com/MSDSXPS-Boards.pdf>.
- Nakagawa, R; Murata, S; Ashizuka, Y; Shintani, Y; Hori, T; Tsutsumi, T. (2010). Hexabromocyclododecane determination in seafood samples collected from Japanese coastal areas. *Chemosphere* 81: 445-452. <http://dx.doi.org/10.1016/j.chemosphere.2010.08.015>.
- Newton, S; Sellstrom, U; de Wit, CA. (2015). Emerging Flame Retardants, PBDEs, and HBCDDs in Indoor and Outdoor Media in Stockholm, Sweden. *Environ Sci Technol* 49: 2912-2920.
<http://dx.doi.org/10.1021/es505946e>.
- NICNAS. (2012a). Hexabromocyclododecane: Priority existing chemical assessment report no. 34. Australia.
http://www.nicnas.gov.au/Publications/CAR/PEC/PEC34/HBCD_Report_June_2012_PDF.pdf.
- NICNAS. (2012b). Priority existing chemical assessments: Hyexabromocyclododecane (HBCD)-PEC34. https://www.nicnas.gov.au/chemical-information/pec-assessments?result_34791_result_page=H.
- NIOSH. (2014a). Evaluation of Occupational Exposures at an Electronic Scrap Recycling Facility. (2012-0100-3217). Washington, DC: U.S. Department of Health and Human Services.
<https://www.cdc.gov/niosh/hhe/reports/pdfs/2012-0100-3217.pdf>.
- NIOSH. (2014b). A Pilot Assessment of Occupational Health Hazards in the U.S. Electronic Scrap Recycling Industry (pp. 26). Washington, DC: U.S. Department of Health and Human Services.
https://www.cdc.gov/niosh/hhe/reports/pdfs/e-scrap_survey_report.pdf.

- NIOSH. (2003). Respirator Usage in Private Sector Firms. Washington D.C.: United States Department of Labor, Bureau of Labor Statistics and National Institute for Occupational Safety and Health. <https://www.cdc.gov/niosh/docs/respsurv/>.
- NRC. (2000a). Hexabromocyclododecane. In Toxicological risk of selected flame-retardant chemicals. Washington, DC: National Academy Press. http://www.nap.edu/openbook.php?record_id=9841&page=53.
- NRC. (2000b). Toxicological risks of selected flame-retardant chemicals. Washington, DC: National Academy Press. <http://dx.doi.org/10.17226/9841>.
- NRC. (2005). Health implications of perchlorate ingestion. Washington, DC: National Academies Press. <http://dx.doi.org/https://doi.org/10.17226/11202>.
- O. D. E. , YSvTA. (2013). ODE isipan. Turkey: ODE Yalitim Sanayi ve Ticaret AS. [http://www.ode.com.tr/assets/upload/kalite_belgeler/ode-isipan-\(en\).pdf](http://www.ode.com.tr/assets/upload/kalite_belgeler/ode-isipan-(en).pdf).
- OECD. (2007). SIDS initial assessment profile: Hexabromocyclododecane (HBCDD) [OECD SIDS]. Paris, France. <http://webnet.oecd.org/HPV/UI/handler.axd?id=ea58ac11-e090-4b24-b281-200ae351686c>.
- OECD. (2009). Emission Scenario Document on Plastic Additives. In Series on Emission Scenario Documents No 3. Paris: OECD Environmental Health and Safety Publications. [http://www.oecd.org/officialdocuments/publicdisplaydocumentpdf/?cote=env/jm/mono\(2004\)8/rev1&doclanguage=en](http://www.oecd.org/officialdocuments/publicdisplaydocumentpdf/?cote=env/jm/mono(2004)8/rev1&doclanguage=en).
- OECD. (2010a). Emission Scenario Document on Chemicals Used in the Electronics Industry. In Series on Emission Scenario Documents No 25. Paris: OECD Environmental Health and Safety Publications. [http://www.oecd.org/officialdocuments/publicdisplaydocumentpdf/?cote=env/jm/mono\(2010\)37&doclanguage=en](http://www.oecd.org/officialdocuments/publicdisplaydocumentpdf/?cote=env/jm/mono(2010)37&doclanguage=en).
- OECD. (2010b). Emission Scenario Document on Formulation of Radiation Curable Coatings, Inks and Adhesives. Paris: OECD Environmental Health and Safety Publications. <http://www.oecd-ilibrary.org/docserver/download/9714171e.pdf?expires=1497031714&id=id&accname=guest&checksum=E5B188BBD13C6D7100D39B8643ABA020>.
- OECD. (2019). Estimating mouthing exposure in children-compilation of case studies. (Series on Testing And Assessment No. 306). [http://www.oecd.org/officialdocuments/publicdisplaydocumentpdf/?cote=ENV-JM-MONO\(2019\)24%20&doclanguage=en](http://www.oecd.org/officialdocuments/publicdisplaydocumentpdf/?cote=ENV-JM-MONO(2019)24%20&doclanguage=en).
- Oetken, M; Ludwichowski, K; Nagel, R. (2001). Validation of the preliminary EU-concept of assessing the impact of chemicals to organisms in sediment by using selected substances. (UBA-FB 299 67 411). Dresden, Germany: Dresden University of Technology, Institute of Hydrobiology.
- Oh, JK; Kotani, K; Managaki, S; Masunaga, S. (2014). Levels and distribution of hexabromocyclododecane and its lower brominated derivative in Japanese riverine environment. Chemosphere 109: 157-163. <http://dx.doi.org/10.1016/j.chemosphere.2014.01.074>.
- Olukunle, OI; Okonkwo, OJ. (2015). Concentration of novel brominated flame retardants and HBCD in leachates and sediments from selected municipal solid waste landfill sites in Gauteng Province, South Africa. Waste Manag 43: 300-306. <http://dx.doi.org/10.1016/j.wasman.2015.07.009>.
- Ortiz, X; Guerra, P; Díaz-Ferrero, J; Eljarrat, E; Barceló, D. (2011). Diastereoisomer- and enantiomer-specific determination of hexabromocyclododecane in fish oil for food and feed. Chemosphere 82: 739-744. <http://dx.doi.org/10.1016/j.chemosphere.2010.10.088>.
- O'Shaughnessy, KL; Thomas, SE; Spring, SR; Ford, JL; Ford, RL; Gilbert, ME. (2019). A transient window of hypothyroidism alters neural progenitor cells and results in abnormal brain development. Sci Rep 9: 4662. <http://dx.doi.org/10.1038/s41598-019-40249-7>.

- Ott, W; Klepeis, N; Switzer, P. (2008). Air change rates of motor vehicles and in-vehicle pollutant concentrations from secondhand smoke. *J Expo Sci Environ Epidemiol* 18: 312-325. <http://dx.doi.org/10.1038/sj.jes.7500601>.
- Ozkaynak, H; Xue, J; Zartarian, VG; Glen, G; Smith, L. (2011). Modeled estimates of soil and dust ingestion rates for children. *Risk Anal* 31: 592-608. <http://dx.doi.org/10.1111/j.1539-6924.2010.01524.x>.
- Palace, V; Park, B; Pleskach, K; Gemmill, B; Tomy, G. (2010). Altered thyroxine metabolism in rainbow trout (*Oncorhynchus mykiss*) exposed to hexabromocyclododecane (HBCD). *Chemosphere* 80: 165-169. <http://dx.doi.org/10.1016/j.chemosphere.2010.03.016>.
- Palace, VP; Pleskach, K; Halldorson, T; Danell, R; Wautier, K; Evans, B; Alae, M; Marvin, C; Tomy, GT. (2008). Biotransformation enzymes and thyroid axis disruption in juvenile rainbow trout (*Oncorhynchus mykiss*) exposed to hexabromocyclododecane diastereoisomers. *Environ Sci Technol* 42: 1967-1972. <http://dx.doi.org/10.1021/es702565h>.
- Paul, KB; Hedge, JM; Devito, MJ; Crofton, KM. (2010). Short-term exposure to triclosan decreases thyroxine in vivo via upregulation of hepatic catabolism in Young Long-Evans rats. *Toxicol Sci* 113: 367-379. <http://dx.doi.org/10.1093/toxsci/kfp271>.
- Pawar, G; Abdallah, MA; de Sáa, EV; Harrad, S. (2016). Dermal bioaccessibility of flame retardants from indoor dust and the influence of topically applied cosmetics. *J Expo Sci Environ Epidemiol* 27: 100-105. <http://dx.doi.org/10.1038/jes.2015.84>.
- Pharmakologisches Institut. (1990). Ames test with hexabromides with cover letter dated 031290 [TSCA Submission]. (TSCATS/406636. OTS0522942. Doc. I.D. 86900000379). Washington, DC: U.S. Environmental Protection Agency.
- Peled, M; Scharia, R; Sondack, D. (1995). Thermal rearrangement of hexabromo-cyclododecane (HBCD). In JR Desmurs; B Gérard; MJ Godlstein (Eds.), (pp. 92-99). New York, NY: Elsevier. [http://dx.doi.org/10.1016/S0926-9614\(05\)80012-7](http://dx.doi.org/10.1016/S0926-9614(05)80012-7).
- Poma, G; Volta, P; Roscioli, C; Bettinetti, R; Guzzella, L. (2014). Concentrations and trophic interactions of novel brominated flame retardants, HBCD, and PBDEs in zooplankton and fish from Lake Maggiore (Northern Italy). *Sci Total Environ* 481: 401-408. <http://dx.doi.org/10.1016/j.scitotenv.2014.02.063>.
- Potter, KE; Watts, BD; La Guardia, MJ; Harvey, EP; Hale, RC. (2009). Polybrominated diphenyl ether flame retardants in Chesapeake Bay region, USA, peregrine falcon (*Falco peregrinus*) eggs: urban/rural trends. *Environ Toxicol Chem* 28: 973-981. <http://dx.doi.org/10.1897/08-350.1>.
- Porch, JR; Kendall, TZ; Krueger, HO. (2002). Hexabromocyclododecane (HBCD): A toxicity test to determine the effects of the test substance on seedling emergence of six species of plants. (126 pp.). Easton, MD: Porch, JR; Kendall, TZ; Krueger, HO.
- Ramu, K; Isobe, T; Takahashi, S; Kim, EY; Min, BY; We, SU; Tanabe, S. (2010). Spatial distribution of polybrominated diphenyl ethers and hexabromocyclododecanes in sediments from coastal waters of Korea. *Chemosphere* 79: 713-719. <http://dx.doi.org/10.1016/j.chemosphere.2010.02.048>.
- Rani, M; Shim, WJ; Jang, M; Han, GM; Hong, SH. (2017). Releasing of hexabromocyclododecanes from expanded polystyrenes in seawater -field and laboratory experiments. *Chemosphere* 185: 798-805. <http://dx.doi.org/10.1016/j.chemosphere.2017.07.042>
- Ransbotyn, G. (1999). Use of HBCD in Flame-Retarded EPS Grades. Letter to KEMI from APME, dated 30 April. 1999.
- Ransbotyn, G. (2000). Input to EU risk assessment on HBCDD from users in EPS and HIPS. Report prepared by the EPS and PS Committees of the APME. Dated 18 February (pp. 25). Brussels, Belgium: Ransbotyn, G.
- Rasinger, JD; Carroll, TS; Maranghi, F; Tassinari, R; Moracci, G; Altieri, I; Mantovani, A; Lundebye, AK; Hogstrand, C. (2018). Low dose exposure to HBCD, CB-153 or TCDD induces histopathological and hormonal effects and changes in brain protein and gene expression in

juvenile female BALB/c mice. *Reprod Toxicol* 80: 105-116.

<http://dx.doi.org/10.1016/j.reprotox.2018.06.010>.

Rawn, DF; Gaertner, DW; Weber, D; Curran, IH; Cooke, GM; Goodyer, CG. (2014a).

Hexabromocyclododecane concentrations in Canadian human fetal liver and placental tissues.

Sci Total Environ 468-469: 622-629. <http://dx.doi.org/10.1016/j.scitotenv.2013.08.014>.

Rawn, DF; Ryan, JJ; Sadler, AR; Sun, WF; Weber, D; Laffey, P; Haines, D; Macey, K; Van Oostdam, J.

(2014b). Brominated flame retardant concentrations in sera from the Canadian Health Measures Survey (CHMS) from 2007 to 2009. *Environ Int* 63: 26-34.

<http://dx.doi.org/10.1016/j.envint.2013.10.012>.

Rege, JM. (2017). Comment submitted by Julia M. Rege, Director, Environment & Energy, Association of Global Automakers, Inc. (Global Automakers) [Comment].

<https://www.regulations.gov/document?D=EPA-HQ-OPPT-2016-0735-0030>.

Remberger, M; Sternbeck, J; Palm, A; Kaj, L; Strömberg, K; Brorström-Lundén, E. (2004). The

environmental occurrence of hexabromocyclododecane in Sweden. *Chemosphere* 54: 9-21.

[http://dx.doi.org/10.1016/S0045-6535\(03\)00758-6](http://dx.doi.org/10.1016/S0045-6535(03)00758-6).

Reyes, L; Mañalich, R. (2005). Long-term consequences of low birth weight [Review]. *Kidney Int*

Suppl 68: S107-S111. <http://dx.doi.org/10.1111/j.1523-1755.2005.09718.x>.

Robson, M; Melymuk, L; Bradley, L; Treen, B; Backus, S. (2013). Wet deposition of brominated flame

retardants to the Great Lakes basin - Status and trends. *Environ Pollut* 182: 299-306.

<http://dx.doi.org/10.1016/j.envpol.2013.07.018>.

Rochman, CM; Hoh, E; Kurobe, T; Teh, SJ. (2013). Ingested plastic transfers hazardous chemicals to

fish and induces hepatic stress. *Sci Rep* 3: 3263. <http://dx.doi.org/10.1038/srep03263>

Rochman, CM; Lewison, RL; Eriksen, M; Allen, H; Cook, AM; Teh, SJ. (2014). Polybrominated

diphenyl ethers (PBDEs) in fish tissue may be an indicator of plastic contamination in marine habitats. *Sci Total Environ* 476-477: 622-633. <http://dx.doi.org/10.1016/j.scitotenv.2014.01.058>

Román, GC; Ghassabian, A; Bongers-Schokking, JJ; Jaddoe, VW; Hofman, A; de Rijke, YB; Verhulst,

FC; Tiemeier, H. (2013). Association of gestational maternal hypothyroxinemia and increased autism risk. *Ann Neurol* 74: 733-742. <http://dx.doi.org/10.1002/ana.23976>.

Ronisz, D; Finne, EF; Karlsson, H; Förlin, L. (2004). Effects of the brominated flame retardants

hexabromocyclododecane (HBCDD), and tetrabromobisphenol A (TBBPA), on hepatic enzymes and other biomarkers in juvenile rainbow trout and feral eelpout. *Aquat Toxicol* 69: 229-245.

<http://dx.doi.org/10.1016/j.aquatox.2004.05.007>.

Roosens, L; Abdallah, MA; Harrad, S; Neels, H; Covaci, A. (2009). Exposure to

hexabromocyclododecanes (HBCDs) via dust ingestion, but not diet, correlates with concentrations in human serum: preliminary results. *Environ Health Perspect* 117: 1707-1712.

<http://dx.doi.org/10.1289/ehp.0900869>.

Roosens, L; Cornelis, C; D'Hollander, W; Bervoets, L; Reynders, H; Van Campenhout, K; Van Den

Heuvel, R; Neels, H; Covaci, A. (2010a). Exposure of the Flemish population to brominated flame retardants: model and risk assessment. *Environ Int* 36: 368-376.

<http://dx.doi.org/10.1016/j.envint.2010.02.005>.

Roosens, L; D'Hollander, W; Bervoets, L; Reynders, H; Van Campenhout, K; Cornelis, C; Van Den

Heuvel, R; Koppen, G; Covaci, A. (2010b). Brominated flame retardants and perfluorinated chemicals, two groups of persistent contaminants in Belgian human blood and milk. *Environ Pollut* 158: 2546-2552. <http://dx.doi.org/10.1016/j.envpol.2010.05.022>.

Roper, CS; Madden, S; Biesemeier, JA; Hoonagel, H; Rothenbacker, K. (2007). The in vitro

percutaneous absorption of radiolabelled hexabromocyclododecane (HBCD) through human skin. *Organohalogen Compd* 69: 2094-2095.

- [Rosenberg, C; Hämeilä, M; Tornaues, J; Säkkinen, K; Puttonen, K; Korpi, A; Kiilunen, M; Linnainmaa, M; Hesso, A.](#) (2011). Exposure to flame retardants in electronics recycling sites. *Ann Occup Hyg* 55: 658-665. <http://dx.doi.org/10.1093/annhyg/mer033>.
- [Rosol, TJ; DeLellis, RA; Harvey, PW; Sutcliffe, C.](#) (2013). Endocrine system. In W Haschek; C Rousseaux; M Wallig (Eds.), (3rd ed., pp. 2391–2492). Waltham, MA: Academic Press. <http://dx.doi.org/10.1016/B978-0-12-415759-0.00058-3>.
- [Roze, E; Meijer, L; Bakker, A; Van Braeckel, KNJ, A; Sauer, PJJ; Bos, AF.](#) (2009). Prenatal exposure to organohalogens, including brominated flame retardants, influences motor, cognitive, and behavioral performance at school age. *Environ Health Perspect* 117: 1953-1958. <http://dx.doi.org/10.1289/ehp.0901015>.
- [Ruan, Y; Zhang, K; Wu, C; Wu, R; Lam, PK.](#) (2019). A preliminary screening of HBCD enantiomers transported by microplastics in wastewater treatment plants. *Sci Total Environ* 674: 171-178.
- [Ryan, JJ; Rawn, DF.](#) (2014). The brominated flame retardants, PBDEs and HBCD, in Canadian human milk samples collected from 1992 to 2005; concentrations and trends. *Environ Int* 70: 1-8. <http://dx.doi.org/10.1016/j.envint.2014.04.020>.
- [Ryan, JJ; Wainman, BC; Schecter, A; Moisey, SA; Kosarac, I; Sun, WF.](#) (2006). Trends of the brominated flame retardants, PBDES and HBCD, in human milks from North America. *Organohalogen Compd* 68: 778-781.
- [Saegusa, Y; Fujimoto, H; Woo, GH; Inoue, K; Takahashi, M; Mitsumori, K; Hirose, M; Nishikawa, A; Shibutani, M.](#) (2009). Developmental toxicity of brominated flame retardants, tetrabromobisphenol A and 1,2,5,6,9,10-hexabromocyclododecane, in rat offspring after maternal exposure from mid-gestation through lactation. *Reprod Toxicol* 28: 456-467. <http://dx.doi.org/10.1016/j.reprotox.2009.06.011>.
- [Safer Chemicals, HFEHSCBHN.](#) (2017). Comments to the U.S. Environmental Protection Agency (EPA) on the Scope of its Risk Evaluation for the TSCA Work Plan Chemicals: Cyclic Aliphatic Bromide Cluster Or Hexabromocyclododecane (HBCD) CAS Reg. Nos. 25637-99-4, 3194-55-6, 3194-57-8. Submitted on March 15, 2017.
- [Sahlström, L; Sellström, U; de Wit, CA.](#) (2012). Clean-up method for determination of established and emerging brominated flame retardants in dust. *Anal Bioanal Chem* 404: 459-466. <http://dx.doi.org/10.1007/s00216-012-6160-y>.
- [Sahlström, LM; Sellström, U; de Wit, CA; Lignell, S; Darnerud, PO.](#) (2015). Estimated intakes of brominated flame retardants via diet and dust compared to internal concentrations in a Swedish mother-toddler cohort. *Int J Hyg Environ Health* 218: 422-432. <http://dx.doi.org/10.1016/j.ijheh.2015.03.011>.
- [Saito, I; Onuki, A; Seto, H.](#) (2007). Indoor organophosphate and polybrominated flame retardants in Tokyo. *Indoor Air* 17: 28-36. <http://dx.doi.org/10.1111/j.1600-0668.2006.00442.x>.
- [Sanders, JM; Knudsen, GA; Birnbaum, LS.](#) (2013). The Fate of β -Hexabromocyclododecane in Female C57BL/6 Mice. *Toxicol Sci* 134: 251-257. <http://dx.doi.org/10.1093/toxsci/kft121>.
- [Santa Cruz Biotechnology, I.](#) (2009). Material safety data sheet (MSDS): 1,2,5,6,9,10-hexabromocyclododecane. Santa Cruz, California: Santa Cruz Biotechnology Inc. <http://datasheets.scbt.com/sc-222899.pdf>.
- [Santillo, D; Johnston, P; Brigden, K.](#) (2001). The presence of brominated flame retardants and organotin compounds in dusts collected from Parliament buildings from eight countries. Santillo, D; Johnston, P; Brigden, K. <http://archive.greenpeace.org/toxics/reports/eudust.pdf>.
- [Santillo, D; Labunska, I; Davidson, H; Johnston, P; Strutt, M; Knowles, O.](#) (2003). Consuming chemicals: Hazardous chemicals in house dust as an indicator of chemical exposure in the home. London, UK: Greenpeace Environmental Trust. <http://www.greenpeace.org/international/en/publications/reports/consuming-chemicals-hazardou/>.

- [SCCH](#). (2018a). Amendments to Annexes to the Stockholm Convention. Available online at <http://chm.pops.int/Countries/StatusofRatifications/Amendmentstoannexes/tabid/3486/Default.aspx>
- [SCCH](#). (2018b). Import and export of POPs. Available online at <http://chm.pops.int/Implementation/ImportandexportofPOPs/Overview/tabid/4455/Default.aspx>
- [SCCH](#). (2018c). Register of Specific Exemptions. Available online at <http://chm.pops.int/Implementation/Exemptions/RegisterofSpecificExemptions/tabid/1133/Default.aspx>
- [Schechter, A; Szabo, DT; Miller, J; Gent, TL; Malik-Bass, N; Petersen, M; Paepke, O; Colacino, JA; Hynan, LS; Harris, TR; Malla, S; Birnbaum, LS](#). (2012). Hexabromocyclododecane (HBCD) Stereoisomers in U.S. Food from Dallas, Texas. *Environ Health Perspect* 120: 1260-1264. <http://dx.doi.org/10.1289/ehp.1204993>.
- [Schlummer, M; Maurer, A; Wagner, S; Berrang, A; Siebert, T; Knappich, F](#). (2017). Recycling of flame retarded waste polystyrene foams (EPS and XPS) to PS granules free of hexabromocyclododecane (HBCDD). *Schlummer, M; Maurer, A; Wagner, S; Berrang, A; Siebert, T; Knappich, F*. http://www.synbratechnology.com/media/11693/fraunhoferwebsite_creasolv-processing-of-hbcd-containing-polystyrene-from-construction-eps-1.pdf.
- [Schreder, ED; La Guardia, MJ](#). (2014). Flame retardant transfers from U.S. households (dust and laundry wastewater) to the aquatic environment. *Environ Sci Technol* 48: 11575-11583. <http://dx.doi.org/10.1021/es502227h>.
- [Schriks, M; Vrabie, CM; Gutleb, AC; Faassen, EJ; Rietjens, IM; Murk, AJ](#). (2006). T-screen to quantify functional potentiating, antagonistic and thyroid hormone-like activities of poly halogenated aromatic hydrocarbons (PHAHs). *Toxicol In Vitro* 20: 490-498. <http://dx.doi.org/10.1016/j.tiv.2005.09.001>.
- [Schriks, M; Zvinavashe, E; Furlow, JD; Murk, AJ](#). (2006). Disruption of thyroid hormone-mediated *Xenopus laevis* tadpole tail tip regression by hexabromocyclododecane (HBCD) and 2,2',3,3',4,4',5,5',6-nona brominated diphenyl ether (BDE206). *Chemosphere* 65: 1904-1908. <http://dx.doi.org/10.1016/j.chemosphere.2006.07.077>
- [Searl, A; Robertson, A](#). (2005). Workplace exposure to hexabromocyclododecane (HBCD) in the European Union. Report for the European Brominated Flame Retardant Industry Panel. Searl, A; Robertson, A.
- [Sellstrom, U; Kierkegaard, A; De Wit, C; Jansson, B](#). (1998). Polybrominated diphenyl ethers and hexabromocyclododecane in sediment and fish from a Swedish River. *Environ Toxicol Chem* 17: 1065-1072. [http://dx.doi.org/10.1897/1551-5028\(1998\)017<1065:PDEAHI>2.3.CO;2](http://dx.doi.org/10.1897/1551-5028(1998)017<1065:PDEAHI>2.3.CO;2).
- [Shaw, SD; Berger, ML; Weijjs, L; Covaci, A](#). (2012). Tissue-specific accumulation of polybrominated diphenyl ethers (PBDEs) including Deca-BDE and hexabromocyclododecanes (HBCDs) in harbor seals from the northwest Atlantic. *Environ Int* 44: 1-6. <http://dx.doi.org/10.1016/j.envint.2012.01.001>.
- [Shaw, SD; Berger, ML; Harris, JH; Yun, SH; Wu, Q; Liao, C; Blum, A; Stefani, A; Kannan, K](#). (2013). Persistent organic pollutants including polychlorinated and polybrominated dibenzo-p-dioxins and dibenzofurans in firefighters from Northern California. *Chemosphere* 91: 1386-1394. <http://dx.doi.org/http://dx.doi.org/10.1016/j.chemosphere.2012.12.070>
- [Shelby, MK; Cherrington, NJ; Vansell, NR; Klaassen, CD](#). (2003). Tissue mRNA expression of the rat UDP-glucuronosyltransferase gene family. *Drug Metab Dispos* 31: 326-333. <http://dx.doi.org/10.1124/dmd.31.3.326>.
- [Shen, B; Whitehead, TP; Gill, R; Dhaliwal, J; Brown, FR; Petreas, M; Patton, S; Hammond, SK](#). (2018). Organophosphate flame retardants in dust collected from United States fire Stations. *Environ Int* 112: 41-48. <http://dx.doi.org/https://doi.org/10.1016/j.envint.2017.12.009>

- Shi, D; Lv, D; Liu, W; Shen, R; Li, D; Hong, H. (2017a). Accumulation and developmental toxicity of hexabromocyclododecanes (HBCDs) on the marine copepod *Tigriopus japonicus*. *Chemosphere* 167: 155-162. <http://dx.doi.org/10.1016/j.chemosphere.2016.09.160>.
- Shi, Z; Zhang, L; Zhao, Y; Sun, Z; Zhou, X; Li, J; Wu, Y. (2017b). Dietary exposure assessment of Chinese population to tetrabromobisphenol-A, hexabromocyclododecane and decabrominated diphenyl ether: Results of the 5th Chinese total diet study. *Environ Pollut* 229: 539-547. <http://dx.doi.org/10.1016/j.envpol.2017.06.093>.
- Shoeib, M; Ahrens, L; Jantunen, L; Harner, T, om. (2014). Concentrations in air of organobromine, organochlorine and organophosphate flame retardants in Toronto, Canada. *Atmos Environ* 99: 140-147. <http://dx.doi.org/10.1016/j.atmosenv.2014.09.040>.
- Shoeib, M; Harner, T; Webster, GM; Sverko, E; Cheng, Y. (2012). Legacy and current-use flame retardants in house dust from Vancouver, Canada. *Environ Pollut* 169: 175-182. <http://dx.doi.org/10.1016/j.envpol.2012.01.043>.
- Shoeib, M; Harner, T; Wilford, BH; Jones, KC; Zhu, J. (2005). Perfluorinated sulfonamides in indoor and outdoor air and indoor dust: occurrence, partitioning, and human exposure. *Environ Sci Technol* 39: 6599-6606. <http://dx.doi.org/10.1021/es048340y>.
- Smith, K; Liu, CH; El-Hiti, GA; Kang, GS; Jones, E; Clement, SG; Checquer, AD; Howarth, OW; Hursthouse, MB; Coles, SJ. (2005). An extensive study of bromination of cis,trans,trans-1,5,9-cyclododecatriene: product structures and conformations. *Org Biomol Chem* 3: 1880-1892. <http://dx.doi.org/10.1039/b417156j>.
- Smolarz, K; Berger, A. (2009). Long-term toxicity of hexabromocyclododecane (HBCDD) to the benthic clam *Macoma balthica* (L.) from the Baltic Sea. *Aquat Toxicol* 95: 239-247. <http://dx.doi.org/10.1016/j.aquatox.2009.09.010>.
- Son, MH; Kim, J; Shin, ES; Seo, SH; Chang, YS. (2015). Diastereoisomer- and species-specific distribution of hexabromocyclododecane (HBCD) in fish and marine invertebrates. *J Hazard Mater* 300: 114-120. <http://dx.doi.org/10.1016/j.jhazmat.2015.06.023>.
- Song, N; Li, L; Li, H; Ai, W; Xie, W; Yu, W; Liu, W; Wang, C; Shen, G; Zhou, L; Wei, C; Li, D; Chen, H. (2016). Single and 14-day repeated dose inhalation toxicity studies of hexabromocyclododecane in rats. *Food Chem Toxicol* 91: 73-81. <http://dx.doi.org/10.1016/j.fct.2016.02.020>.
- SRI International. (1990). In vitro microbiological mutagenicity studies of four Ciba-Geigy Corporation compounds (final report) with test data and cover letter [TSCA Submission]. (TSCATS/407254. OTS0523254. Doc I.D. 86900000262). West Lafayette, IN: Great Lakes Chemical Corporation. <https://ntrl.ntis.gov/NTRL/dashboard/searchResults.xhtml?searchQuery=OTS0523254>.
- Stapleton, H; Allen, J; Kelly, S; Konstantinov, A; Klosterhaus, S; Watkins, D; Mcclean, M; Webster, T. (2008). Alternate and new brominated flame retardants detected in U.S. house dust. *Environ Sci Technol* 42: 6910-6916. <http://dx.doi.org/10.1021/es801070p>.
- Stapleton, HM; Misenheimer, J; Hoffman, K; Webster, TF. (2014). Flame retardant associations between children's handwipes and house dust. *Chemosphere* 116: 54-60. <http://dx.doi.org/10.1016/j.chemosphere.2013.12.100>.
- Stiborova, H; Kolar, M; Vrkoslavova, J; Pulkrabova, J; Hajslova, J; Demnerova, K; Uhlik, O. (2017). Linking toxicity profiles to pollutants in sludge and sediments. *J Hazard Mater* 321: 672-680. <http://dx.doi.org/10.1016/j.jhazmat.2016.09.051>.
- Stubbings, WA; Harrad, S. (2019). Laboratory studies on leaching of HBCDD from building insulation foams. *Emerging Contaminants* 5: 36-44.
- Sun, J; Dai, X; Wang, Q; van Loosdrecht, MC; Ni, BJ. (2019). Microplastics in wastewater treatment plants: Detection, occurrence and removal. *Water Res* 152: 21-37.
- Sun, YX; Luo, XJ; Mo, L; He, MJ; Zhang, Q; Chen, SJ; Zou, FS; Mai, BX. (2012). Hexabromocyclododecane in terrestrial passerine birds from e-waste, urban and rural locations in

the Pearl River Delta, South China: levels, biomagnification, diastereoisomer- and enantiomer-specific accumulation. *Environ Pollut* 171: 191-198.

<http://dx.doi.org/10.1016/j.envpol.2012.07.026>.

Sustainable Electronics Recycling, I. (2020). Find a Recycler [Website].

<https://sustainableelectronics.org/recyclers>.

Suter, G. (2016). Weight of evidence in ecological assessment. (EPA100R16001). Washington, DC: U.S. Environmental Protection Agency.

https://cfpub.epa.gov/si/si_public_record_report.cfm?dirEntryId=335523.

Szabo, DT; Diliberto, JJ; Hakk, H; Huwe, JK; Birnbaum, LS. (2010). Toxicokinetics of the flame retardant hexabromocyclododecane gamma: effect of dose, timing, route, repeated exposure, and metabolism. *Toxicol Sci* 117: 282-293. <http://dx.doi.org/10.1093/toxsci/kfq183>.

Szabo, DT; Diliberto, JJ; Hakk, H; Huwe, JK; Birnbaum, LS. (2011a). Toxicokinetics of the flame retardant hexabromocyclododecane alpha: effect of dose, timing, route, repeated exposure, and metabolism. *Toxicol Sci* 121: 234-244. <http://dx.doi.org/10.1093/toxsci/kfr059>.

Szabo, DT; Diliberto, JJ; Huwe, JK; Birnbaum, LS. (2011b). Differences in tissue distribution of HBCD alpha and gamma between adult and developing mice. *Toxicol Sci* 123: 256-263.

<http://dx.doi.org/10.1093/toxsci/kfr161>.

Takigami, H; Suzuki, G; Hirai, Y; Ishikawa, Y; Sunami, M; Sakai, S. (2009). Flame retardants in indoor dust and air of a hotel in Japan. *Environ Int* 35: 688-693.

<http://dx.doi.org/10.1016/j.envint.2008.12.007>.

Takigami, H; Suzuki, G; Hirai, Y; Sakai, S. (2008). Transfer of brominated flame retardants from components into dust inside television cabinets. *Chemosphere* 73: 161-169.

<http://dx.doi.org/10.1016/j.chemosphere.2008.06.032>.

Takigami, H; Watanabe, M; Kajiwara, N. (2014). Destruction behavior of hexabromocyclododecanes during incineration of solid waste containing expanded and extruded polystyrene insulation foams. *Chemosphere* 116: 24-33. <http://dx.doi.org/10.1016/j.chemosphere.2014.01.082>.

Tang, J; Feng, J; Li, X; Li, G. (2014). Levels of flame retardants HBCD, TBBPA and TBC in surface soils from an industrialized region of East China. *Environ Sci Process Impacts* 16: 1015-1021.

<http://dx.doi.org/10.1039/c3em00656e>.

Tao, F; Abou-Elwafa Abdallah, M; Ashworth, DC; Douglas, P; Toledano, MB; Harrad, S. (2017). Emerging and legacy flame retardants in UK human milk and food suggest slow response to restrictions on use of PBDEs and HBCDD. *Environ Int* 105: 95-104.

<http://dx.doi.org/10.1016/j.envint.2017.05.010>.

Tao, F; Matsukami, H; Suzuki, G; Tue, NM; Viet, PH; Takigami, H; Harrad, S. (2016). Emerging halogenated flame retardants and hexabromocyclododecanes in food samples from an e-waste processing area in Vietnam. *Environ Sci Process Impacts* 18: 361-370.

<http://dx.doi.org/10.1039/c5em00593k>.

Tatman, S. (2017). Comment submitted by Stacy Tatman, MS, JD, Director, Environmental Affairs, Alliance of Automobile Manufacturers (Alliance).

<https://www.regulations.gov/document?D=EPA-HQ-OPPT-2016-0723-0010>

Tay, JH; Sellström, U; Papadopoulou, E; Padilla-Sánchez, JA; Haug, LS; de Wit, CA. (2018).

Assessment of dermal exposure to halogenated flame retardants: Comparison using direct measurements from hand wipes with an indirect estimation from settled dust concentrations. *Environ Int* 115: 285-294. <http://dx.doi.org/10.1016/j.envint.2018.03.038>.

TCEQ. (2017). Study on the economic impacts of recycling, final report.

<https://www.tceq.texas.gov/assets/public/assistance/P2Recycle/study/TheStudyontheEconomicImpactsOfRecycling.pdf>.

Teuten, EL; Saquing, JM; Knappe, DR; Barlaz, MA; Jonsson, S; Björn, A; Rowland, SJ; Thompson, RC; Galloway, TS; Yamashita, R; Ochi, D; Watanuki, Y; Moore, C; Viet, PH; Tana, TS;

- [Prudente, M; Boonyatumanond, R; Zakaria, MP; Akkhavong, K; Ogata, Y; Hirai, H; Iwasa, S; Mizukawa, K; Hagino, Y; Imamura, A; Saha, M; Takada, H.](#) (2009). Transport and release of chemicals from plastics to the environment and to wildlife [Review]. *Philos Trans R Soc Lond B Biol Sci* 364: 2027-2045. <http://dx.doi.org/10.1098/rstb.2008.0284>
- [Thomsen, C; Molander, P; Daae, HL; Janák, K; Frøshaug, M; Liane, VH; Thorud, S; Becher, G; Dybing, E.](#) (2007). Occupational exposure to hexabromocyclododecane at an industrial plant. *Environ Sci Technol* 41: 5210-5216. <http://dx.doi.org/10.1021/es0702622>.
- [Thomsen, C; Stigum, H; Frøshaug, M; Broadwell, SL; Becher, G; Eggesbø, M.](#) (2010). Determinants of brominated flame retardants in breast milk from a large scale Norwegian study. *Environ Int* 36: 68-74. <http://dx.doi.org/10.1016/j.envint.2009.10.002>.
- [Tian, S; Sebroski, J; Ecoff, S.](#) (2017). ASTM STP 1589 — Developing Consensus Standards for Measuring Chemical Emissions from Spray Polyurethane Foam (SPF) Insulation Predicting TCPPEmissions and Airborne Concentrations from Spray Polyurethane Foam Using USEPA i-SVOC software: Parameter Estimation and Result Interpretation. West Conshohocken, PA: ASTM International.
- [Tickner, J; Friar, J; Creely, KS; Cherrie, JW; Pryde, DE; Kingston, J.](#) (2005). The Development of the EASE Model. *Ann Occup Hyg* 49: 105-110.
- [Tomko, G; McDonald, KM.](#) (2013). Environmental fate of hexabromocyclododecane from a new Canadian electronic recycling facility. *J Environ Manage* 114: 324-327. <http://dx.doi.org/10.1016/j.jenvman.2012.10.024>.
- [Toms, LM; Guerra, P; Eljarrat, E; Barceló, D; Harden, FA; Hobson, P; Sjodin, A; Ryan, E; Mueller, JF.](#) (2012). Brominated flame retardants in the Australian population: 1993-2009. *Chemosphere* 89: 398-403. <http://dx.doi.org/10.1016/j.chemosphere.2012.05.053>.
- [Tomy, GT; Budakowski, W; Halldorson, T; Whittle, DM; Keir, MJ; Marvin, C; Macinnis, G; Alae, M.](#) (2004). Biomagnification of alpha- and gamma-hexabromocyclododecane isomers in a Lake Ontario food web. *Environ Sci Technol* 38: 2298-2303. <http://dx.doi.org/10.1021/es034968h>.
- [Tomy, GT; Pleskach, K; Oswald, T; Halldorson, T; Helm, PA; Macinnis, G; Marvin, CH.](#) (2008). Enantioselective bioaccumulation of hexabromocyclododecane and congener-specific accumulation of brominated diphenyl ethers in an eastern Canadian Arctic marine food web. *Environ Sci Technol* 42: 3634-3639. <http://dx.doi.org/10.1021/es703083z>.
- [Townsend, T; Ingwersen, W; Niblick, B; Jain, P; Wally, J.](#) (2019). CDDPath: A method for quantifying the loss and recovery of construction and demolition debris in the United States. *Waste Manag* 84: 302-309. <http://dx.doi.org/10.1016/j.wasman.2018.11.048>.
- [U.S. BLS.](#) (2014). Employee Tenure News Release. Available online at http://www.bls.gov/news.release/archives/tenure_09182014.htm
- [U.S. BLS.](#) (2016). May 2016 Occupational Employment and Wage Estimates: National Industry-Specific Estimates [Website]. <http://www.bls.gov/oes/tables.htm>.
- [U.S. EPA.](#) (1987). Development Document for Effluent Limitations Guidelines and Standards for the Organic Chemicals, Plastics and Synthetic Fibers; Point Source Category, Volume I. (440187009A). <http://nepis.epa.gov/exe/ZyPURL.cgi?Dockey=00001BGD.txt>.
- [U.S. EPA.](#) (1991). Guidelines for developmental toxicity risk assessment (pp. 1-71). (EPA/600/FR-91/001). Washington, DC: U.S. Environmental Protection Agency, Risk Assessment Forum. <http://cfpub.epa.gov/ncea/cfm/recorddisplay.cfm?deid=23162>.
- [U.S. EPA.](#) (1992). Guidelines for exposure assessment. Federal Register 57(104):22888-22938 [EPA Report]. (EPA/600/Z-92/001). Washington, DC. <http://cfpub.epa.gov/ncea/cfm/recorddisplay.cfm?deid=15263>.
- [U.S. EPA.](#) (1993a). Determination of rates of reaction in the gas-phase in the troposphere. 5. Rate of indirect photoreaction: Evaluation of the atmospheric oxidation computer program of Syracuse Research Corporation for estimating the second-order rate constant for the reaction of an organic

chemical with hydroxyl radicals. (EPA-744-R-93-001). Office of Pollution Prevention and Toxics.

U.S. EPA. (1993b). Wildlife exposures factors handbook. Appendix: literature review database. vol 2 [EPA Report]. (EPA/600/R-93/187b). Washington, D.C.

<https://ntrl.ntis.gov/NTRL/dashboard/searchResults.xhtml?searchQuery=PB94177789>.

U.S. EPA. (1994). Methods for derivation of inhalation reference concentrations and application of inhalation dosimetry [EPA Report]. (EPA/600/8-90/066F). Research Triangle Park, NC: U.S. Environmental Protection Agency, Office of Research and Development, Office of Health and Environmental Assessment, Environmental Criteria and Assessment Office.

<https://cfpub.epa.gov/ncea/risk/recordisplay.cfm?deid=71993&CFID=51174829&CFTOKEN=25006317>.

U.S. EPA. (1995). Final Water Quality Guidance for the Great Lakes System. 60: 15366-15422.

U.S. EPA. (1996). Guidelines for reproductive toxicity risk assessment (pp. 1-143). (EPA/630/R-96/009). Washington, DC: U.S. Environmental Protection Agency, Risk Assessment Forum.

https://www.epa.gov/sites/production/files/2014-11/documents/guidelines_repro_toxicity.pdf.

U.S. EPA. (1998a). Guidelines for ecological risk assessment [EPA Report]. (EPA/630/R-95/002F). Washington, DC: U.S. Environmental Protection Agency, Risk Assessment Forum.

<https://www.epa.gov/risk/guidelines-ecological-risk-assessment>.

U.S. EPA. (1998b). Characterization of building-related construction and demolition debris in the United States. Franklin Associates. <https://www.epa.gov/smm/characterization-building-related-construction-and-demolition-debris-united-states>.

U.S. EPA. (2000a). Methodology for deriving ambient water quality criteria for the protection of human health (2000). (EPA/822/B-00/004). Washington, DC: U.S. Environmental Protection Agency, Office of Water. <http://www.epa.gov/waterscience/criteria/humanhealth/method/complete.pdf>.

U.S. EPA. (2000b). Science policy council handbook: Risk characterization [EPA Report]. (EPA/100/B-00/002). Washington, D.C.: U.S. Environmental Protection Agency, Science Policy Council.

<https://www.epa.gov/risk/risk-characterization-handbook>.

U.S. EPA. (2002). A review of the reference dose and reference concentration processes (pp. 1-192). (EPA/630/P-02/002F). Washington, DC: U.S. Environmental Protection Agency, Risk Assessment Forum.

<http://www.epa.gov/osa/review-reference-dose-and-reference-concentration-processes>.

U.S. EPA. (2003a). Methodology for deriving ambient water quality criteria for the protection of human health (2000), technical support document. Volume 2: Development of national bioaccumulation factors [EPA Report]. (EPA-822-R-03-030). Washington, DC.

<http://www.epa.gov/waterscience/criteria/humanhealth/method/tsdvol2.pdf>.

U.S. EPA. (2003b). Estimating 2003 building-related construction and demolition materials amounts. <https://www.epa.gov/smm/estimating-2003-building-related-construction-and-demolition-materials-amounts>.

U.S. EPA. (2004). Risk Assessment Guidance for Superfund (RAGS), Volume I: Human health evaluation manual, (part E: Supplemental guidance for dermal risk assessment): Final. (EPA/540/R/99/005). Washington, DC.

<http://www.epa.gov/oswer/riskassessment/ragse/index.htm>.

U.S. EPA. (2005). Guidelines for carcinogen risk assessment [EPA Report] (pp. 1-166). (EPA/630/P-03/001F). Washington, DC: U.S. Environmental Protection Agency, Risk Assessment Forum.

<http://www2.epa.gov/osa/guidelines-carcinogen-risk-assessment>.

U.S. EPA. (2006). A framework for assessing health risk of environmental exposures to children (pp. 1-145). (EPA/600/R-05/093F). Washington, DC: U.S. Environmental Protection Agency, Office of Research and Development, National Center for Environmental Assessment.

<http://cfpub.epa.gov/ncea/cfm/recordisplay.cfm?deid=158363>.

- [U.S. EPA](#). (2008a). Initial risk-based prioritization of high production volume chemicals: Chemical/category: Hexabromocyclododecane (HBCD), CAS 3194-55-6 1,2,5,6,9,10 hexabromocyclododecane, CAS 25637-99-4 hexabromocyclododecane. Washington, DC.
- [U.S. EPA](#). (2008b). Lifecycle construction resource guide. Pollution Prevention Program Office, Office of Policy and Management, EPA Region 4.
<https://nepis.epa.gov/Exe/ZyPURL.cgi?Dockey=P1009HH1.TXT>.
- [U.S. EPA](#). (2009a). Air quality criteria for particulate matter.
- [U.S. EPA](#). (2009b). Consolidated Human Activity Database [Website]. <http://www.epa.gov/chadnet1/>.
- [U.S. EPA](#). (2009c). User's guide and technical documentation: KABAM version 1.0 (Kow (based Aquatic BioAccumulation Model)). https://www.epa.gov/sites/production/files/2015-07/documents/kabam_v1_0_users_guide.pdf.
- [U.S. EPA](#). (2010). Hexabromocyclododecane (HBCD) action plan summary [EPA Report]. Washington, D.C. <https://www.epa.gov/assessing-and-managing-chemicals-under-tsca/hexabromocyclododecane-hbcd-action-plan>.
- [U.S. EPA](#). (2011a). EPI Suite results for CASRN 3194-55-6. Download EPI Suite TM v4.0. Available online at
- [U.S. EPA](#). (2011b). Exposure Factors Handbook: 2011 Edition. (EPA/600/R-09/052F). Washington, DC: U.S. EPA. <http://www.epa.gov/ncea/efh>.
- [U.S. EPA](#). (2011c). Recommended use of body weight 3/4 as the default method in derivation of the oral reference dose (pp. 1-50). (EPA/100/R11/0001). Washington, DC: U.S. Environmental Protection Agency, Risk Assessment Forum, Office of the Science Advisor.
<https://www.epa.gov/risk/recommended-use-body-weight-34-default-method-derivation-oral-reference-dose>.
- [U.S. EPA](#). (2012a). Benchmark dose technical guidance. (EPA/100/R-12/001). Washington, DC: U.S. Environmental Protection Agency, Risk Assessment Forum.
<https://www.epa.gov/risk/benchmark-dose-technical-guidance>.
- [U.S. EPA](#). (2012b). Estimation Programs Interface Suite™ for Microsoft® Windows, v 4.11 [Computer Program]. Washington, DC. Retrieved from <https://www.epa.gov/tsca-screening-tools/epi-suitetm-estimation-program-interface>
- [U.S. EPA](#). (2012c). Sustainable futures P2 framework manual [EPA Report]. (EPA-748-B12-001). Washington DC. <http://www.epa.gov/sustainable-futures/sustainable-futures-p2-framework-manual>.
- [U.S. EPA](#). (2012d). TSCA work plan chemicals: Methods document (pp. 1-28). Washington, DC: U.S. Environmental Protection Agency, Office of Pollution Prevention and Toxics.
https://www.epa.gov/sites/production/files/2014-03/documents/work_plan_methods_document_web_final.pdf.
- [U.S. EPA](#). (2013a). ChemSTEER User Guide - Chemical Screening Tool for Exposures and Environmental Releases. Environmental Protection Agency.
https://www.epa.gov/sites/production/files/2015-05/documents/user_guide.pdf.
- [U.S. EPA](#). (2013b). ChemSTEER User Guide: Chemical Screening Tool for Exposures and Environmental Release. U.S. Environmental Protection Agency (EPA).
- [U.S. EPA](#). (2013c). Interpretive assistance document for assessment of discrete organic chemicals. Sustainable futures summary assessment [EPA Report]. Washington, DC.
http://www.epa.gov/sites/production/files/2015-05/documents/05-iad_discretres_june2013.pdf.
- [U.S. EPA](#). (2014a). Draft Emission Scenario Document (ESD) on the Use of Additives in Plastic Compounding. Chantilly, VA: Eastern Research Group.
- [U.S. EPA](#). (2014b). Estimated Fish Consumption Rates for the U.S. Population and Selected Subpopulations (NHANES 2003-2010) (pp. 110). (EPA-820-R-14-002). Washington, DC.
<https://www.epa.gov/sites/production/files/2015-01/documents/fish-consumption-rates->

- [2014.pdf.https://hero.epa.gov/hero/index.cfm?action=search.view&reference_id=4565445](https://hero.epa.gov/hero/index.cfm?action=search.view&reference_id=4565445)[U.S. EPA](https://www.epa.gov/saferchoice/partnership-evaluate-flame-retardant-alternatives-hbcd-publications). (2014d). Flame retardant alternatives for hexabromocyclododecane (HBCD) [EPA Report]. (EPA/740/R-14/001). Washington, D.C. <http://www2.epa.gov/saferchoice/partnership-evaluate-flame-retardant-alternatives-hbcd-publications>.
- [U.S. EPA](https://www.epa.gov/tsca-screening-tools/e-fast-exposure-and-fate-assessment-screening-tool-version-2014). (2014c). Exposure and Fate Assessment Screening Tool Version 2014 (E-FAST 2014). Washington, DC: Office of Pollution Prevention and Toxics. <https://www.epa.gov/tsca-screening-tools/e-fast-exposure-and-fate-assessment-screening-tool-version-2014>
- [U.S. EPA](http://www2.epa.gov/saferchoice/partnership-evaluate-flame-retardant-alternatives-hbcd-publications). (2014d). Flame retardant alternatives for hexabromocyclododecane (HBCD) [EPA Report]. (EPA/740/R-14/001). Washington, D.C. <http://www2.epa.gov/saferchoice/partnership-evaluate-flame-retardant-alternatives-hbcd-publications>
- [U.S. EPA](https://www.epa.gov/risk/framework-human-health-risk-assessment-inform-decision-making). (2014e). Framework for human health risk assessment to inform decision making. Final [EPA Report]. (EPA/100/R-14/001). Washington, DC: U.S. Environmental Protection, Risk Assessment Forum. <https://www.epa.gov/risk/framework-human-health-risk-assessment-inform-decision-making>.
- [U.S. EPA](https://ofmpub.epa.gov/eims/eimscomm.getfile?p_download_id=521738). (2014f). Preliminary materials for the Integrated Risk Information System (IRIS) Toxicological review of hexabromocyclododecane (HBCD). In National Center for Environmental Assessment, Office of Research and Development (pp. 84). (EPA/630/R-13/235). Washington, DC: U.S. Environmental Protection Agency. https://ofmpub.epa.gov/eims/eimscomm.getfile?p_download_id=521738.
- [U.S. EPA](https://www.epa.gov/sites/production/files/2015-09/documents/hbcd_problem_formulation.pdf). (2015a). TSCA Work Plan chemical problem formulation and initial assessment. Cyclic aliphatic bromide cluster flame retardants. (EPA 743-D1-5001). Washington, DC. https://www.epa.gov/sites/production/files/2015-09/documents/hbcd_problem_formulation.pdf.
- [U.S. EPA](https://www.epa.gov/sites/production/files/2015-08/documents/ftt_sop_using_nafta_guidance_version2.pdf). (2015b). Standard Operating Procedure for Using the NAFTA Guidance to Calculate Representative Half-life Values and Characterizing Pesticide Degradation. https://www.epa.gov/sites/production/files/2015-08/documents/ftt_sop_using_nafta_guidance_version2.pdf
- [U.S. EPA](https://www.epa.gov/sites/production/files/2016-02/documents/u_s_epa_fact_sheet_implementation_study_1.pdf). (2016a). Implementation Study of the Electronics Recycling Standards: R2 and e-Stewards® (pp. 4). Washington, DC. https://www.epa.gov/sites/production/files/2016-02/documents/u_s_epa_fact_sheet_implementation_study_1.pdf.
- [U.S. EPA](https://www.epa.gov/chemical-data-reporting/instructions-reporting-2016-tsca-chemical-data-reporting). (2016b). Instructions for reporting 2016 TSCA chemical data reporting. Washington, DC: Office of Pollution Prevention and Toxics. <https://www.epa.gov/chemical-data-reporting/instructions-reporting-2016-tsca-chemical-data-reporting>.
- [U.S. EPA](https://www.epa.gov/chemical-data-reporting). (2016c). Non-confidential 2016 Chemical Data Reporting (CDR) Database.
- [U.S. EPA](https://www.epa.gov/chemical-data-reporting). (2016d). Public database 2016 chemical data reporting (May 2017 release). Washington, DC: US Environmental Protection Agency, Office of Pollution Prevention and Toxics. Retrieved from <https://www.epa.gov/chemical-data-reporting>
- [U.S. EPA](https://www.regulations.gov/document?D=EPA-HQ-TRI-2015-0607-0028). (2016e). Technical review of hexabromocyclododecane (HBCD) CAS registry numbers 3194-55-6 and 25637-99-4. Washington, DC: U. S. Environmental Protection Agency. <https://www.regulations.gov/document?D=EPA-HQ-TRI-2015-0607-0028>.
- [U.S. EPA](https://www.epa.gov/sites/production/files/2017-06/documents/14dioxane_comp_bib.pdf). (2017a). 1,4-dioxane (CASRN: 123-91-1) bibliography: Supplemental file for the TSCA Scope Document [EPA Report]. https://www.epa.gov/sites/production/files/2017-06/documents/14dioxane_comp_bib.pdf.
- [U.S. EPA](https://www.epa.gov/sites/production/files/2017-06/documents/hbcd_comp_bib.pdf). (2017b). Cyclic aliphatic bromides cluster (HBCD) (CASRN: 25637-99- 4; 3194-55-6; 3194-57-8) bibliography: Supplemental file for the TSCA Scope Document [EPA Report]. https://www.epa.gov/sites/production/files/2017-06/documents/hbcd_comp_bib.pdf.
- [U.S. EPA](https://www.regulations.gov/document?D=EPA-HQ-OPPT-2016-0735-0106). (2017c). Re: Phase Down of HBCD by Dow Chemical, EMAIL from Christine Lukas to Sue Slotnick. <https://www.regulations.gov/document?D=EPA-HQ-OPPT-2016-0735-0106>.

- U.S. EPA. (2017d). Scope of the Risk Evaluation for cyclic aliphatic bromides cluster [EPA Report]. (EPA-740-R1-7002). https://www.epa.gov/sites/production/files/2017-06/documents/hbcd_scope_06-22-17_0.pdf.
- U.S. EPA. (2017e). Scope of the Risk Evaluation for Pigment Violet 29 (Anthra[2,1,9-def:6,5,10-d'e'f']diisoquinoline-1,3,8,10(2H,9H)-tetrone): CASRN: 81-33-4 [EPA Report]. (740-R1-7011). U.S. EPA, Office of Chemical Safety and Pollution Prevention, Office of Pollution Prevention and Toxics. https://www.epa.gov/sites/production/files/2017-06/documents/pv29_scope_06-22-17.pdf.
- U.S. EPA. (2017f). Strategy for conducting literature searches for cyclic aliphatic bromine cluster (HBCD): Supplemental document to the TSCA Scope Document. CASRN: 25637-99-4; 3194-55-6; 3194-57-8 [EPA Report]. https://www.epa.gov/sites/production/files/2017-06/documents/hbcd_lit_search_strategy_053017.pdf.
- U.S. EPA. (2017g). Toxics Release Inventory (TRI) basic plus data file, Hexabromocyclododecane (CAS # 25637-99-4), reporting year 2017. Retrieved from <https://www.epa.gov/toxics-release-inventory-tri-program/tri-basic-plus-data-files-calendar-years-1987-2017>
- U.S. EPA. (2017h). Toxics Release Inventory (TRI), reporting year 2015. <https://www.epa.gov/toxics-release-inventory-tri-program/tri-data-and-tools>.
- U.S. EPA. (2017i). Update for chapter 5 of the Exposure Factors Handbook: Soil and Dust Ingestion [EPA Report]. (EPA/600R-17/384F). Washington, DC: National Center for Environmental Assessment, Office of Research and Development. <https://cfpub.epa.gov/ncea/efp/recordisplay.cfm?deid=337521>.
- U.S. EPA. (2017j). Use and market profile for hexabromocyclododecane (HBCD). Draft.
- U.S. EPA. (2018a). Advancing sustainable materials management: 2015 fact sheet. https://www.epa.gov/sites/production/files/2018-07/documents/2015_smm_msw_factsheet_07242018_fnl_508_002.pdf.
- U.S. EPA. (2018b). Application of systematic review in TSCA Risk Evaluation s. (740-P1-8001). Washington, DC: U.S. Environmental Protection Agency, Office of Chemical Safety and Pollution Prevention. https://www.epa.gov/sites/production/files/2018-06/documents/final_application_of_sr_in_tsc_a_05-31-18.pdf.
- U.S. EPA. (2018c). Application of systematic review in TSCA Risk Evaluation s: DRAFT Version 1.0. (740P18001). Washington, D.C.: U.S. Environmental Protection Agency, Office of Chemical Safety and Pollution Prevention.
- U.S. EPA. (2018d). Draft Generic Scenario on the Application of Spray Polyurethane Foam (SPF). Chantilly, VA: Eastern Research Group.
- U.S. EPA. (2018e). ECOTOX user guide: ECOTOXicology database system. Version 5.0. <https://cfpub.epa.gov/ecotox/>
- U.S. EPA. (2018f). Problem formulation of the risk evaluation for C.I. Pigment Violet 29 (Anthra[2,1,9-def:6,5,10-d'e'f']diisoquinoline1,3,8,10(2H,9H)-tetrone). CASRN: 81-33-4 [EPA Report]. (EPA Document# 740-R1-7021). United States Environmental Protection Agency , Office of Chemical Safety and Pollution Prevention, Office of Pollution Prevention and Toxics. <https://www.epa.gov/assessing-and-managing-chemicals-under-tsca/pigment-violet-29-anthra219-def6510-defdiisoquinoline-0>
- U.S. EPA. (2018g). Problem formulation of the Risk Evaluation for cyclic aliphatic bromides cluster (HBCD). (EPA-740-R1-7012). Washington, DC: Office of Chemical Safety and Pollution Prevention, United States Environmental Protection Agency. https://www.epa.gov/sites/production/files/2018-06/documents/hbcd_problem_formulation_05-31-18.pdf.
- U.S. EPA. (2018h). Strategy for assessing data quality in TSCA Risk Evaluation s. Washington DC: U.S. Environmental Protection Agency, Office of Pollution Prevention and Toxics.

- U.S. EPA. (2018i). Update for chapter 9 of the Exposure Factors Handbook: Intake of Fruits and Vegetables [EPA Report]. (EPA/600/R-18/098F). Washington, DC: National Center for Environmental Assessment, Office of Research and Development.
<https://cfpub.epa.gov/ncea/efp/recordisplay.cfm?deid=341764>.
- U.S. EPA. (2018j). Update for chapter 11 of the Exposure Factors Handbook: Intake Of Meats, Dairy Products, And Fats [EPA Report]. (EPA/600/R-17/485F). Washington, DC: National Center for Environmental Assessment, Office of Research and Development.
<https://cfpub.epa.gov/ncea/efp/recordisplay.cfm?deid=340600>.
- U.S. EPA. (2018k). Sustainable management of construction and demolition materials [Website].
<https://www.epa.gov/smm/sustainable-management-construction-and-demolition-materials>.
- U.S. EPA. (2019a). Risk Evaluation for Cyclic Aliphatic Bromide Cluster (HBCD), Supplemental File: Occupational Exposure and Environmental Releases Calculations.
<https://www.regulations.gov/docket?D=EPA-HQ-OPPT-2019-0237>
- U.S. EPA. (2019b). Risk Evaluation for Cyclic Aliphatic Bromide Cluster (HBCD), Systematic Review Supplemental File: Data Extraction Tables of Environmental Hazard Studies. .
<https://www.regulations.gov/docket?D=EPA-HQ-OPPT-2019-0237>.
- U.S. EPA. (2019c). Risk Evaluation for Cyclic Aliphatic Bromide Cluster (HBCD), Systematic Review Supplemental File: Updates to the Data Quality Criteria for Epidemiological Studies. .
<https://www.regulations.gov/docket?D=EPA-HQ-OPPT-2019-0237>.
- U.S. EPA. (2019d). Risk Evaluation for Cyclic Aliphatic Bromides Cluster (HBCD), Supplemental Information on General Population, Environmental, and Consumer Exposure Assessment. .
<https://www.regulations.gov/docket?D=EPA-HQ-OPPT-2019-0237>.
- U.S. EPA. (2019e). Risk Evaluation for Cyclic Aliphatic Bromides Cluster (HBCD), Supplemental Information on Human Health Hazard.
<https://www.regulations.gov/docket?D=EPA-HQ-OPPT-2019-0237>.
- U.S. EPA. (2019f). Risk Evaluation for Cyclic Aliphatic Bromides Cluster (HBCD), Systematic Review Supplemental File: Data Extraction of General Population and Environmental Exposure Studies
<https://www.regulations.gov/docket?D=EPA-HQ-OPPT-2019-0237>.
- U.S. EPA. (2019g). Risk Evaluation for Cyclic Aliphatic Bromides Cluster (HBCD), Systematic Review Supplemental File: Data Extraction Tables for Human Health Hazard Studies. .
<https://www.regulations.gov/docket?D=EPA-HQ-OPPT-2019-0237>.
- U.S. EPA. (2019h). Risk Evaluation for Cyclic Aliphatic Bromides Cluster (HBCD), Systematic Review Supplemental File: Data Extraction Tables of Environmental Fate and Transport Studies.
<https://www.regulations.gov/docket?D=EPA-HQ-OPPT-2019-0237>.
- U.S. EPA. (2019i). Risk Evaluation for Cyclic Aliphatic Bromides Cluster (HBCD), Systematic Review Supplemental File: Data Quality Evaluation for Occupational Exposure and Release Data for Common Sources. <https://www.regulations.gov/docket?D=EPA-HQ-OPPT-2019-0237>.
- U.S. EPA. (2019j). Risk Evaluation for Cyclic Aliphatic Bromides Cluster (HBCD), Systematic Review Supplemental File: Data Quality Evaluation for Occupational Exposure and Release Data.
<https://www.regulations.gov/docket?D=EPA-HQ-OPPT-2019-0237>.
- U.S. EPA. (2019k). Risk Evaluation for Cyclic Aliphatic Bromides Cluster (HBCD), Systematic Review Supplemental File: Data Quality Evaluation of Ecological Hazard Studies.
<https://www.regulations.gov/docket?D=EPA-HQ-OPPT-2019-0237>.
- U.S. EPA. (2019l). Risk Evaluation for Cyclic Aliphatic Bromides Cluster (HBCD), Systematic Review Supplemental File: Data Quality Evaluation of Environmental Fate and Transport Studies. .
<https://www.regulations.gov/docket?D=EPA-HQ-OPPT-2019-0237>.
- U.S. EPA. (2019m). Risk Evaluation for Cyclic Aliphatic Bromides Cluster (HBCD), Systematic Review Supplemental File: Data Quality Evaluation of General Population and Environmental Exposure Studies. <https://www.regulations.gov/docket?D=EPA-HQ-OPPT-2019-0237>.

- U.S. EPA. (2019n). Risk Evaluation for Cyclic Aliphatic Bromides Cluster (HBCD), Systematic Review Supplemental File: Data Quality Evaluation of Human Health Hazard Studies. <https://www.regulations.gov/docket?D=EPA-HQ-OPPT-2019-0237>.
- U.S. EPA. (2019o). Durable Goods: Product-Specific Data. <https://www.epa.gov/facts-and-figures-about-materials-waste-and-recycling/durable-goods-product-specific-data#Electronics>.
- U.S. EPA. (2019p). IECCU 1.1 User's Guide. In Simulation Program for Estimating Chemical Emissions from Sources and Related Changes to Indoor Environmental Concentrations in Buildings with Conditioned and Unconditioned Zones (IECCU). (EPA Contract # EP-W-12-010). Washington, DC: U.S. Environmental Protection Agency, Office of Pollution Prevention and Toxics.
- U.S. EPA. (2019q). Point Source Calculator: A Model for Estimating Chemical Concentration in Water Bodies. Washington, DC: U.S. Environmental Protection Agency, Office of Chemical Safety and Pollution Prevention.
- U.S. EPA. (2019r). User's Guide: Integrated Indoor-Outdoor Air Calculator (IIOAC). Washington, DC: U.S. EPA.
- U.S. EPA. (2019s). Risk Evaluation for Cyclic Aliphatic Bromide Cluster (HBCD), Supplemental File: Occupational Risk Calculator. <https://www.regulations.gov/docket?D=EPA-HQ-OPPT-2019-0237>.
- U.S. EPA. (2019t). Risk Evaluation for Cyclic Aliphatic Bromides Cluster (HBCD), Systematic Review Supplemental File: Data Quality Evaluation of Physical-Chemical Properties Studies. <https://www.regulations.gov/docket?D=EPA-HQ-OPPT-2019-0237>.
- U.S. EPA. (2019t). Risk Evaluation for Cyclic Aliphatic Bromides Cluster (HBCD), Systematic Review Supplemental File: Data Quality Evaluation of Physical-Chemical Properties Studies. <https://www.regulations.gov/docket?D=EPA-HQ-OPPT-2019-0237>.
- U.S. EPA. (2020). Memorandum: NIOSH/BLS Respirator Usage in Private Sector Firms [Personal Communication]. <https://www.regulations.gov/document?D=EPA-HQ-OPPT-2019-0500-0029>.
- UNEP. (2010a). Hexabromocyclododecane draft risk profile (pp. 1-39). Europe. <http://chm.pops.int/Convention/POPsReviewCommittee/hrPOPRCMeetings/POPRC5/POPRC5Followupcommunications/HBCDInvitationforcommentsondraftRP/tabid/742/language/en-US/Default.aspx>.
- UNEP. (2010b). Report of the Persistent Organic Pollutants Review Committee on the Work of Its Sixth Meeting. Addendum. Risk Profile on Hexabromocyclododecane (pp. 44). Châtelaine, Switzerland. <http://chm.pops.int/TheConvention/POPsReviewCommittee/Meetings/POPRC6/POPRC6ReportandDecisions/tabid/1312/Default.aspx>.
- UNEP. (2011). Report of the Persistent Organic Pollutants Review Committee on the Work of Its Seventh Meeting. Addendum. Risk management evaluation on hexabromocyclododecane. In Stockholm Convention on Persistent Organic Pollutants. (UNEP/POPS/POPRC.7/19/Add.1). Geneva, Switzerland. <http://chm.pops.int/Convention/POPsReviewCommittee/POPRCMeetings/POPRC7/POPRC7ReportandDecisions/tabid/2472/Default.aspx>
- van Beusekom, OC; Eljarrat, E; Barceló, D; Koelmans, AA. (2006). Dynamic modeling of food-chain accumulation of brominated flame retardants in fish from the Ebro River Basin, Spain. *Environ Toxicol Chem* 25: 2553-2560. <http://dx.doi.org/10.1897/05-409R.1>.
- van der Ven, LT; Verhoef, A; van de Kuil, T; Slob, W; Leonards, PE; Visser, TJ; Hamers, T; Herlin, M; Håkansson, H; Olausson, H; Piersma, AH; Vos, JG. (2006). A 28-day oral dose toxicity study enhanced to detect endocrine effects of hexabromocyclododecane in Wistar rats. *Toxicol Sci* 94: 281-292. <http://dx.doi.org/10.1093/toxsci/kfl113>.

- van der Ven, LTM; van de Kuil, T; Leonards, PEG; Slob, W; Lilienthal, H; Litens, S; Herlin, M; Håkansson, H; Cantón, RF; van den Berg, M; Visser, TJ; van Loveren, H; Vos, JG; Piersma, AH. (2009). Endocrine effects of hexabromocyclododecane (HBCD) in a one-generation reproduction study in Wistar rats. *Toxicol Lett* 185: 51-62. <http://dx.doi.org/10.1016/j.toxlet.2008.12.003>.
- van Raaij, MTM; Jansen, PAH; Piersma, AH. (2003a). The relevance of developmental toxicity endpoints for acute limit setting. (601900004). Bilthoven: RIVM.
- Van Raaij, MTM; Janssen, PAH; Piersma, AH. (2003b). The relevance of developmental toxicity endpoints for acute limits settings (pp. 1-88). (RIVM Report 601900004). Netherlands: Netherlands National Institute for Public Health and the Environment. <http://www2.epa.gov/sites/production/files/2014-04/documents/mtg35b.pdf>.
- Vansell, NR; Klaassen, CD. (2002). Effect of microsomal enzyme inducers on the biliary excretion of triiodothyronine (T(3)) and its metabolites. *Toxicol Sci* 65: 184-191. <http://dx.doi.org/10.1093/toxsci/65.2.184>.
- Veith, GD; DeFoe, DL; Bergstedt, BV. (1979). Measuring and estimating the bioconcentration factor of chemicals in fish. *J Fish Res Board Can* 36: 1040-1048. <http://dx.doi.org/10.1139/f79-146>.
- Velsicol Chem Corp. (1978). Industrial hygiene survey, Velsicol Chemical Corporation, El Dorado, Ark Plant, Fire Master 680 Unit and semi-works summary with attachments and cover letter dated 071978 [TSCA Submission]. (EPA/OTS Doc #88-7800228). Chicago, IL. <https://ntrl.ntis.gov/NTRL/dashboard/searchResults.xhtml?searchQuery=OTS0200544>.
- Venier, M; Dove, A; Romanak, K; Backus, S; Hites, R. (2014). Flame retardants and legacy chemicals in Great Lakes' water. *Environ Sci Technol* 48: 9563-9572. <http://dx.doi.org/10.1021/es501509r>.
- Venkatesan, AK; Halden, RU. (2014). Brominated flame retardants in U.S. biosolids from the EPA national sewage sludge survey and chemical persistence in outdoor soil mesocosms. *Water Res* 55: 133-142. <http://dx.doi.org/10.1016/j.watres.2014.02.021>.
- Vojta, Š; Bečanová, J; Melymuk, L; Komprdová, K; Kohoutek, J; Kukučka, P; Klánová, J. (2017). Screening for halogenated flame retardants in European consumer products, building materials and wastes. *Chemosphere* 168: 457-466. <http://dx.doi.org/10.1016/j.chemosphere.2016.11.032>.
- Vorkamp, K; Bossi, R; Riget, FF; Skov, H; Sonne, C; Dietz, R. (2015). Novel brominated flame retardants and dechlorane plus in Greenland air and biota. *Environ Pollut* 196: 284-291. <http://dx.doi.org/10.1016/j.envpol.2014.10.007>.
- Waindzioch, A. (2000). Technical report of workplace air-measurements with respect to inhalable dust and hexabromocyclododecane (HBCD) at broomchemie B.V., Terneuzen (pp. 7). (100/00443-00). Taunusstein, Germany: Waindzioch, A.
- Walsh, GE; Yoder, MJ; Mclaughlin, LL; Lores, EM. (1987). Responses of marine unicellular algae to brominated organic compounds in six growth media. *Ecotoxicol Environ Saf* 14: 215-222.
- Waste Business Journal. (2019). Directory of waste processing & disposal sites 2019 (US edition) [Website]. <https://www.wasteinfo.com/diratlas.htm>.
- Watanabe, W; Shimizu, T; Sawamura, R; Hino, A; Konno, K; Hirose, A; Kurokawa, M. (2010). Effects of tetrabromobisphenol A, a brominated flame retardant, on the immune response to respiratory syncytial virus infection in mice. *Int Immunopharmacol* 10: 393-397. <http://dx.doi.org/10.1016/j.intimp.2009.12.014>.
- Weil, ED; Levchik, SV. (2009). Flame Retardants for Plastics and Textiles. Munich, Germany: Carl Hanser Verlag GmbH & Co.KG. <http://dx.doi.org/10.3139/9783446430655.fm>.
- Weschler, CJ; Nazaroff, WW. (2010). SVOC partitioning between the gas phase and settled dust indoors. *Atmos Environ* 44: 3609-3620. <http://dx.doi.org/10.1016/j.atmosenv.2010.06.029>.
- WHO. (2012). Guidance for immunotoxicity risk assessment for chemicals. (Harmonization Project Document No. 10). Geneva, Switzerland. <http://www.inchem.org/documents/harmproj/harmproj/harmproj10.pdf>.

- [WIL Research](#). (1997). Twenty-eight day repeated dose oral toxicity study of HBCD in rats, with cover letter dated 3/18/1997 [TSCA Submission]. (TSCATS/445005. OTS0558957. Doc I.D. #86970000747). Washington, DC: Chemical Manufacturers Association.
<https://ntrl.ntis.gov/NTRL/dashboard/searchResults.xhtml?searchQuery=OTS0558957>.
- [WIL Research](#). (2001). 90-Day oral (gavage) toxicity study of HBCD in rats. (WIL-186012). Washington, DC: Chemical Manufacturers Association.
- [Wildlife Intl, LTD](#). (1997a). Letter from Chem MFGS Assoc to USEPA regarding: toxicological investigation of hexabromocyclododecane (HBCD) with attachments, dated 06/27/1997 [TSCA Submission]. (EPA/OTS Doc #FYI-OTS-1097-1306).
<https://ntrl.ntis.gov/NTRL/dashboard/searchResults/titleDetail/OTS0001306.xhtml>.
- [Wildlife Intl, LTD](#). (1996). Hexabromocyclododecane (HBCD): Closed bottle test with cover letter dated 12/12/1996. (EPA/OTS; Doc #86970000357). Arlington, VA: Chemical Manufactures Association.
- [Wildlife Intl, LTD](#). (1997a). Hexabromocyclododecane (HBCD): Determination of n-octanol/water partition coefficient with cover letter dated 06/27/1997 [TSCA Submission]. (EPA/OTS Doc #86970000802). Washington, DC: Chemical Manufacturers Association.
<https://ntrl.ntis.gov/NTRL/dashboard/searchResults/titleDetail/OTS0573665.xhtml>.
- [Wildlife Intl, LTD](#). (1997b). Letter from Chem Mfgs Assoc to USEPA Regarding: Toxicological Investigation of Hexabromocyclododecane (HBCD) with Attachments, Dated 06/27/1997 [TSCA Submission] (pp. 328). (OTS0001306; EPA/OTS; Doc #FYI-OTS-1097-1306).
- [Wildlife Intl, LTD](#). (1997c). Hexabromocyclododecane (HBCD): Determination of the vapor pressure using a spinning rotor gauge with cover letter dated 08/15/1997 [TSCA Submission]. (EPA/OTS Doc #86970000839). Chemical Manufacturers Association.
<https://ntrl.ntis.gov/NTRL/dashboard/searchResults.xhtml?searchQuery=OTS0573702>.
- [Wildlife Intl, LTD](#). (1998). Initial submission: Hexabromocyclododecane (HBCD) - a flow-through life-cycle toxicity test with the cladoceran (*Daphnia magna*), final report, with cover letter dated 5/18/1998 (pp. EPA/OTS; Doc #FYI-OTS-0698-1333).
- [Wildlife Intl, LTD](#). (2000). Letter from Amer Chem Cncl submitting flow-through bioconcentration test w/rainbow trout and end-user survey-phase 1 study of brominated flame retardant, w/attchmts and dated 8/28/00 [TSCA Submission]. (EPA/OTS Doc #FYI-OTS-1000-1392). Arlington, VA: American Chemistry Council.
- [Wildlife Intl LTD](#). (1997). Hexabromocyclododecane (HBCD): A 48-Hour Flow-Through Acute Toxicity Test With The Cladoceran (*Daphnia Magna*) With Cover Letter Dated 06/20/1997. In Technical Report TSCATS 452984 (pp. (EPA/OTS 1097-1300)). (TSCATS/452984).
- [Wu, JP; Guan, YT; Zhang, Y; Luo, XJ; Zhi, H; Chen, SJ; Mai, BX](#). (2010). Trophodynamics of hexabromocyclododecanes and several other non-PBDE brominated flame retardants in a freshwater food web. *Environ Sci Technol* 44: 5490-5495. <http://dx.doi.org/10.1021/es101300t>.
- [Wu, JP; Guan, YT; Zhang, Y; Luo, XJ; Zhi, H; Chen, SJ; Mai, BX](#). (2011). Several current-use, non-PBDE brominated flame retardants are highly bioaccumulative: evidence from field determined bioaccumulation factors. *Environ Int* 37: 210-215.
<http://dx.doi.org/10.1016/j.envint.2010.09.006>.
- [Wu, M; Wu, D; Wang, C; Guo, Z; Li, B; Zuo, Z](#). (2016a). Hexabromocyclododecane exposure induces cardiac hypertrophy and arrhythmia by inhibiting miR-1 expression via up-regulation of the homeobox gene Nkx2.5. *J Hazard Mater* 302: 304-313.
<http://dx.doi.org/10.1016/j.jhazmat.2015.10.004>.
- [Wu, M; Zuo, Z; Li, B; Huang, L; Chen, M; Wang, C](#). (2013). Effects of low-level hexabromocyclododecane (HBCD) exposure on cardiac development in zebrafish embryos. *Ecotoxicology* 22: 1200-1207. <http://dx.doi.org/10.1007/s10646-013-1107-4>.

- [Wu, MH; Han, T; Xu, G; Zang, C; Li, YJ; Sun, R; Xu, BT; Sun, Y; Chen, FF; Tang, L.](#) (2016b). Occurrence of Hexabromocyclododecane in soil and road dust from mixed-land-use areas of Shanghai, China, and its implications for human exposure. *Sci Total Environ* 559: 282-290. <http://dx.doi.org/10.1016/j.scitotenv.2016.03.166>.
- [Wu, T; Huang, H; Zhang, S.](#) (2016c). Accumulation and phytotoxicity of technical hexabromocyclododecane in maize. *J Environ Sci* 42: 97-104. <http://dx.doi.org/10.1016/j.jes.2015.06.018>.
- [Wu, T; Wang, S; Huang, H; Zhang, S.](#) (2012). Diastereomer-specific uptake, translocation, and toxicity of hexabromocyclododecane diastereoisomers to maize. *J Agric Food Chem* 60: 8528-8534. <http://dx.doi.org/10.1021/jf302682p>.
- [XPSA.](#) (2017a). [Letter from John Ferraro, XPSA, to Sue Slotnick, EPA, regarding Hexabromocyclododecane (HBCD)].
- [XPSA.](#) (2017b). Preliminary information on manufacturing, processing, distribution, use, and disposal: Cyclic aliphatic bromide cluster (HBCD). OCSPP. Public comment. (EPA-HQ-OPPT-2016-0735-0017).
- [Yamashita, R; Takada, H; Fukuwaka, MA; Watanuki, Y.](#) (2011). Physical and chemical effects of ingested plastic debris on short-tailed shearwaters, *Puffinus tenuirostris*, in the North Pacific Ocean. *Mar Pollut Bull* 62: 2845-2849. <http://dx.doi.org/10.1016/j.marpolbul.2011.10.008>
- [Yanagisawa, R; Koike, E; Win-Shwe, TT; Yamamoto, M; Takano, H.](#) (2014). Impaired lipid and glucose homeostasis in hexabromocyclododecane-exposed mice fed a high-fat diet. *Environ Health Perspect* 122: 277-283. <http://dx.doi.org/10.1289/ehp.1307421>.
- [Yang, R; Wei, H; Guo, J; Li, A.](#) (2012). Emerging brominated flame retardants in the sediment of the Great Lakes. *Environ Sci Technol* 46: 3119-3126. <http://dx.doi.org/10.1021/es204141p>.
- [Yi, S; Liu, JG; Jin, J; Zhu, J.](#) (2016). Assessment of the occupational and environmental risks of hexabromocyclododecane (HBCD) in China. *Chemosphere* 150: 431-437. <http://dx.doi.org/10.1016/j.chemosphere.2016.01.047>.
- [Yu, CC; Atallah, YH.](#) (1980). Pharmacokinetics of HBCD in rats [unpublished]. Rosemont, IL: Vesicol Chemical Corporation.
- [Yu, L; Luo, X; Zheng, X; Zeng, Y; Chen, D; Wu, J; Mai, B.](#) (2013). Occurrence and biomagnification of organohalogen pollutants in two terrestrial predatory food chains. *Chemosphere* 93: 506-511. <http://dx.doi.org/10.1016/j.chemosphere.2013.06.023>.
- [Zegers, BN; Mets, A; Van Bommel, R; Minkenberg, C; Hamers, T; Kamstra, JH; Pierce, GJ; Boon, JP.](#) (2005). Levels of hexabromocyclododecane in harbor porpoises and common dolphins from western European seas, with evidence for stereoisomer-specific biotransformation by cytochrome p450. *Environ Sci Technol* 39: 2095-2100. <http://dx.doi.org/10.1021/es049209t>.
- [Zeiger, E; Anderson, B; Haworth, S; Lawlor, T; Mortelmans, K; Speck, W.](#) (1987). Salmonella mutagenicity tests: III. Results from the testing of 255 chemicals. *Environ Mutagen* 9: 1-109. <http://dx.doi.org/10.1002/em.2860090602>.
- [Zeng, YH; Tang, B; Luo, XJ; Zheng, XB; Peng, PA; Mai, BX.](#) (2016). Organohalogen pollutants in surface particulates from workshop floors of four major e-waste recycling sites in China and implications for emission lists. *Sci Total Environ* 569-570: 982-989. <http://dx.doi.org/10.1016/j.scitotenv.2016.06.053>.
- [Zhang, H; Kuo, YY; Gerecke, AC; Wang, J.](#) (2012). Co-release of hexabromocyclododecane (HBCD) and Nano- and microparticles from thermal cutting of polystyrene foams. *Environ Sci Technol* 46: 10990-10996. <http://dx.doi.org/10.1021/es302559v>.
- [Zhang, X; Yang, F; Zhang, X; Xu, Y; Liao, T; Song, S; Wang, J.](#) (2008). Induction of hepatic enzymes and oxidative stress in Chinese rare minnow (*Gobiocypris rarus*) exposed to waterborne hexabromocyclododecane (HBCDD). *Aquat Toxicol* 86: 4-11. <http://dx.doi.org/10.1016/j.aquatox.2007.07.002>.

- Zhang, Y; Sun, H; Liu, F; Dai, Y; Qin, X; Ruan, Y; Zhao, L; Gan, Z. (2013). Hexabromocyclododecanes in limnic and marine organisms and terrestrial plants from Tianjin, China: diastereomer- and enantiomer-specific profiles, biomagnification, and human exposure. *Chemosphere* 93: 1561-1568. <http://dx.doi.org/10.1016/j.chemosphere.2013.08.004>.
- Zhang, Y; Sun, H; Ruan, Y. (2014a). Enantiomer-specific accumulation, depuration, metabolization and isomerization of hexabromocyclododecane (HBCD) diastereomers in mirror carp from water. *J Hazard Mater* 264: 8-15. <http://dx.doi.org/10.1016/j.jhazmat.2013.10.062>.
- Zhang, Y; Sun, H; Zhu, H; Ruan, Y; Liu, F; Liu, X. (2014b). Accumulation of hexabromocyclododecane diastereomers and enantiomers in two microalgae, *Spirulina subsalsa* and *Scenedesmus obliquus*. *Ecotoxicol Environ Saf* 104: 136-142. <http://dx.doi.org/10.1016/j.ecoenv.2014.02.027>.
- Zhou, T; Ross, DG; Devito, MJ; Crofton, KM. (2001). Effects of short-term in vivo exposure to polybrominated diphenyl ethers on thyroid hormones and hepatic enzyme activities in weanling rats. *Toxicol Sci* 61: 76-82.
- Zhu, C; Wang, P; Li, Y; Chen, Z; Li, H; Ssebugere, P; Zhang, Q; Jiang, G. (2017). Trophic transfer of hexabromocyclododecane in the terrestrial and aquatic food webs from an e-waste dismantling region in East China. *Environ Sci Process Impacts* 19: 154-160. <http://dx.doi.org/10.1039/c6em00617e>.
- Ziccardi, LM; Edgington, A; Hentz, K; Kulacki, KJ; Kane Driscoll, S. (2016). Microplastics as vectors for bioaccumulation of hydrophobic organic chemicals in the marine environment: A state-of-the-science review [Review]. *Environ Toxicol Chem* 35: 1667-1676. <http://dx.doi.org/10.1002/etc.3461>
- Zoeller, RT; Tan, SW; Tyl, RW. (2007). General background on the hypothalamic-pituitary-thyroid (HPT) axis [Review]. *Crit Rev Toxicol* 37: 11-53. <http://dx.doi.org/10.1080/10408440601123446>.

APPENDICES

Appendix A REGULATORY HISTORY

A.1 Federal Laws and Regulations

Table_Apx A-1. Federal Laws and Regulations

Statutes/Regulations	Description of Authority/Regulation	Description of Regulation
Toxic Substances Control Act (TSCA) – Section 5(a)	Once EPA determines that a use of a chemical substance is a significant new use under TSCA section 5(a), persons are required to submit a significant new use notice (SNUN) to EPA at least 90 days before they manufacture (including import) or process the chemical substance for that use.	In September 2015, EPA promulgated a SNUR to designate manufacture or processing of HBCD for use as a flame retardant in consumer textiles (apart from use in motor vehicles) as a significant new use. Manufacturers (which includes importers) and processors are required to notify EPA 90 days before commencing the activity (80 FR 57293, September 23, 2015).
TSCA – Section 6(b)	EPA is directed to identify and begin Risk Evaluations on 10 chemical substances drawn from the 2014 update of the TSCA Work Plan for Chemical Assessments.	Cyclic Aliphatic Bromide Cluster (HBCD) is on the initial list of chemicals to be evaluated for unreasonable risk under TSCA (81 FR 91927, December 19, 2016).
TSCA – Section 8(a)	The TSCA section 8(a) CDR Rule requires manufacturers (including importers) to give EPA basic exposure-related information on the types, quantities and uses of chemical substances produced domestically and imported into the United States.	HBCD manufacturing (including importing), processing, and use information is reported under the CDR rule (76 FR 50816, August 16, 2011)
TSCA – Section 8(b)	EPA must compile, keep current and publish a list (the TSCA Inventory) of each chemical substance manufactured, processed or imported into the United States.	HBCD (CASRN 25637-99-4 and CASRN 3194-55-6) was on the initial TSCA Inventory and therefore was not subject to EPA's new chemicals review process (60 FR 16309; March 29, 1995).

Emergency Planning and Community Right-to-Know Act (EPCRA) – Section 313	Requires annual reporting from facilities in specific industry sectors that employ 10 or more full-time equivalent employees and that manufacture, process or otherwise use a TRI-listed chemical in quantities above threshold levels.	EPA listed HBCD on the TRI under 81 FR 85440 effective November 28, 2016. The first TRI reporting deadline for HBCD is July 1, 2018.
US EPA Policy on Evaluating Risk to Children (1995)	It is EPA’s policy to consider the risks to infants and children consistently and explicitly as a part of risk assessments generated during its decision making process, including the setting of standards to protect public health and the environment. To the degree permitted by available data in each case, the Agency will develop a separate assessment of risks to infants and children.	HBCD Final Risk Evaluation assessed risks to infants and children.
Executive Order 13045 - Protection of Children from Environmental Health Risks and Safety Risks (1997)	Executive Order (EO) 13045 pertains to environmental health or safety risk that EPA has reason to believe may disproportionately affect children. EO 13045 states that each federal agency “(a) shall make it a high priority to identify and assess environmental health risks and safety risks that may disproportionately affect children; and (b) shall ensure that its policies, programs, activities, and standards address disproportionate risks.”	HBCD Final Risk Evaluation assessed environmental health risks and safety risks that may disproportionately affect children and complied with EO 13045 (62 FR 19885; April 23, 1997).

A.2 State Laws and Regulations

Table_Apx A-2. State Laws and Regulations

State Actions	Description of Action
Classification of HBCD as Chemical of Concern to Children; law requiring reporting by manufacturers	Maine classifies HBCD as a chemical of high concern (Maine 38 M.R.S.A. Section 1693-A(1)) Maine requires manufacturers or distributors to report the use of deca BDE and/or hexabromocyclododecane, when intentionally added to certain children’s products which are sold in the State of Maine. The first reporting deadline was August 31, 2017. (Rule Chapter 889) http://www.maine.gov/dep/safechem/
	Minnesota classifies HBCD as a chemical of high concern (Toxic Free Kids Act Minn. Stat. 2010 116.9401-116.9407)
	Oregon’s Toxic-Free Kids Act requires manufacturers of children's products sold in Oregon to report products containing HBCD or other high priority chemicals of concern for children's health if found at or above specific levels in those products. Ultimately, manufacturers are to remove these chemicals from certain products or seek a waiver. Products that fall

	<p>under this law are those that are marketed to or intended for children. The first deadline for providing notice was January 2018.</p>
	<p>Washington requires manufacturers of children's products sold in Washington to report if their product contains certain chemicals of high concern to children, including HBCD. The law also bans from manufacture or sale, in the state, children's products or residential upholstered furniture containing >1,000 ppm of five flame retardants, including HBCD (Wash. Admin. Code Section 173-334-130)</p>
Other	<p>In California, HBCD is listed as an initial informational candidate under California's Safer Consumer Products regulations, on the state's Proposition 65 list (Cal. Code Regs, tit. 22, Section 69502.3, subd. (a))</p> <p>California lists HBCD as a designated priority chemical for biomonitoring. However, California has not yet started biomonitoring HBCD. (California SB 1379)</p> <p>The Oregon Department of Environmental Quality lists HBCD as a priority persistent pollutant and publishes use, exposure pathways and release data for HBCD (Oregon SB 737)</p> <p>In Massachusetts, HBCD will be reportable under the Toxics Use Reduction Act beginning in reporting year 2018. (300 CMR 41.00)</p>

A.3 International Laws and Regulations

Table_Apx A-3. International Laws and Regulations

Country/Organization	Requirements and Restrictions
Canada	In October 2016, the Regulations Amending the Prohibition of Certain Toxic Substances Regulations, 2012 (the Amendments) were published in the Canada Gazette, Part II: Vol. 150, No. 20 - October 5, 2016 and will come into force in December 2016. The Amendments include controls on HBCD that prohibit HBCD and certain products containing the substance. Time-limited exemptions for certain uses are included to allow industry to phase-out their use of HBCD (Government of Canada).
European Union	HBCD is listed as a substance of very high concern (SVHC) and it is also listed under Annex XIV (Authorisation list) of European Union's Registration, Evaluation, Authorisation and Restriction of Chemicals (REACH). After August 21, 2015, only persons with approved authorization applications may continue to use the chemical (European Chemicals Agency).
	The Waste Electrical and Electronic Equipment (WEEE) directive in the European Union requires the separation of plastics containing brominated flame retardants prior to recycling (European Commission WEEE).
Japan	HBCD is subject to mandatory reporting requirements in Japan under the Chemical Substances Control Law (CSCL); specifically, Japan requires type III monitoring for all substances that may interfere with the survival and/or growth of flora and fauna (Ministry of Economy, Trade and Industry Japan).
United Nations Stockholm Convention on Persistent Organic Pollutants (POPs)	In May 2013, HBCD was added to the United Nations Stockholm Convention list of Persistent Organic Pollutants (POPs) with specific exemptions for production and use in EPS or XPS in buildings. As required by the convention, Parties that use these exemptions must register with the secretariat and the exemptions, unless extended in accordance with the obligations of the Convention, expire five years from after the date of entry into force of the Convention with respect to the particular chemical (SCCH 2018b).

Appendix B LIST OF SUPPLEMENTAL DOCUMENTS

Associated Systematic Review Data Evaluation Documents – Provides additional detail and information on individual study evaluations including criteria and scoring results, and Associated Systematic Review Data Extraction Documents – Provides data extracted from acceptable studies following evaluation of individual studies.

1. *Supplemental File: Supplemental Information on General Population, Environmental, and Consumer Exposures* ([U.S. EPA 2019d](#)).
2. *Supplemental File: Supplemental Information on Human Health Hazard.* ([U.S. EPA 2019e](#)).
3. *Supplemental File: Occupational Exposure and Environmental Release Calculations Spreadsheet.* ([U.S. EPA 2019a](#))
4. *Supplemental File: Occupational Risk Calculator* ([U.S. EPA 2019s](#)).
5. *Systematic Review Supplemental File: Updates to Data Quality Criteria for Epidemiological Studies.* ([U.S. EPA 2019c](#))
6. *Systematic Review Supplemental File: Data Extraction Tables for Environmental Fate and Transport Studies.* ([U.S. EPA 2019h](#))
7. *Systematic Review Supplemental File: Data Quality Evaluation of Environmental Release and Occupational Exposure Data* ([U.S. EPA 2019j](#))
8. *Systematic Review Supplemental File: Data Quality Evaluation for Environmental Release and Occupational Exposure - Common Sources* ([U.S. EPA 2019i](#))
9. *Systematic Review Supplemental File: Data Quality Evaluation for General Population, Environmental, and Consumer Exposure* ([U.S. EPA 2019m](#))
10. *Systematic Review Supplemental File: Data Quality Evaluation of Environmental Hazard Studies* ([U.S. EPA 2019k](#))
11. *Systematic Review Supplemental File: Data Quality Evaluation of Human Health Hazard Studies - Animal, In Vitro, and Epidemiological Studies* ([U.S. EPA 2019n](#))
12. *Systematic Review Supplemental File: Data Quality Evaluation of Environmental Fate and Transport Studies* ([U.S. EPA 2019l](#))
13. *Systematic Review Supplemental File: Data Extraction for General Population, Environmental, and Consumer Exposure* ([U.S. EPA 2019f](#))
14. *Systematic Review Supplemental File: Data Extraction Tables for Human Health Hazard Studies* ([U.S. EPA 2019g](#))

15. *Systematic Review Supplemental File: Data Extraction of Environmental Hazard Studies* ([U.S. EPA 2019b](#))
16. *Systematic Review Supplemental File: Data Quality Evaluation of Physical-Chemical Properties Studies* ([U.S. EPA 2019t](#))

Appendix C FATE AND TRANSPORT

C.1 Biodegradation

A closed bottle screening-level test for ready biodegradability (OECD Guideline 301D, EPA OTS 796.3200) was performed using an initial HBCD concentration of 7.7 mg/L and an activated domestic sludge inoculum ([Wildlife Intl 1996](#) as cited in [ECHA 2008b](#); [Albemarle, 2005](#)). No biodegradation was observed (0% of the theoretical oxygen demand) over the test period of 28 days under the stringent guideline conditions of this test.

Degradation of HBCD during simulation tests with viable microbes, based on OECD 307 and 308, was approximately 61% in anaerobic freshwater sediment, 44% in aerobic freshwater sediment, and 10% in aerobic soil after 112–113 days ([Davis et al. 2006](#); [ECB, 2008](#)). The results from this study correspond to estimated HBCD half-lives of 92 days in anaerobic freshwater sediment, 128, 92, and 72 days for α -, γ -, and β -HBCD, respectively in aerobic freshwater sediment, and >120 days in aerobic soil. An initial total ^{14}C -HBCD concentration of 3.0–4.7 mg/kg dry weight in the sediment and soil systems was used, allowing for quantification of individual isomers, metabolite identification, and mass balance evaluation ([Davis et al. 2006](#); [NICNAS 2012a](#)). Although very high spiking rates can be toxic to microorganisms in biodegradation studies and lead to unrealistically long estimated half-lives, the results of this study did not suggest toxicity to microorganisms. Tests with viable microbes demonstrated increased HBCD degradation compared to the biologically inhibited control studies. In combination, these studies suggest that HBCD will degrade slowly in the environment, although faster in sediment than in soil, faster under anaerobic conditions than aerobic conditions, faster with microbial action than without microbial action, and at different rates for individual HBCD diastereomers (slower for α -HBCD than for the γ - and β - stereoisomers. The same researchers previously conducted a water-sediment simulation test for commercial HBCD based on OECD guideline 308 using nominal HBCD concentrations of 0.034–0.089 mg/kg dry weight ([Davis et al., 2003a, 2005](#); [Albemarle, 2005](#); [ECB, 2008](#)). Aerobic and anaerobic microcosms were pre-incubated at 20 °C for 49 days and at 23 °C for 43–44 days, respectively. HBCD was then added to 14–37 g dry weight freshwater sediment samples in 250 ml serum bottles (water:sediment ratio of 1.6–2.9) and the microcosms were sealed and incubated in the dark at 20 °C for up to 119 days. For the aerobic microcosms, the headspace oxygen concentration was kept above 10–15%. This study evaluated only γ -HBCD and did not address interconversion of HBCD isomers or α - and β -HBCD degradation. Disappearance half-lives of HBCD with sediment collected from Schuylkill River and Neshaminy creek were 11 and 32 days in viable aerobic sediments, respectively (compared to 190 and 30 days in abiotic aerobic controls, respectively), and 1.5 and 1.1 days in viable anaerobic sediments, respectively (compared to 10 and 9.9 days in abiotic anaerobic controls). Data from these tests suggest that anaerobic degradation is faster than aerobic degradation of HBCD in viable and abiotic sediments and that degradation is faster in viable conditions than abiotic conditions. While these findings are consistent with Davis et al. ([2006](#)), the actual degradation rates in this study are much faster. However, results from this study do not provide a reliable indication of HBCD persistence. A mass balance could not be established because only γ -HBCD was used to quantify HBCD concentrations, ^{14}C -radiolabeled HBCD was not used, and degradation products were not identified; therefore, apparent disappearance of HBCD in this study may not reflect biodegradation. In addition, there were concerns that contaminated sediment may have been used, HBCD extraction was incomplete (HBCD recovery varied from 33 to 125 %), and an interfering peak was observed in the LC/MS chromatograms corresponding to γ -HBCD ([NICNAS 2012a](#); [ECHA 2008b](#)).

Similarly, a soil simulation test was conducted based on OECD guideline 307 for commercial HBCD using 50 g dry weight sandy loam soil samples added to 250 ml serum bottles ([Davis et al., 2003b](#); [Davis et al. 2005](#); [Albemarle, 2005](#); [ECHA 2008b](#)). The moisture content was 20% by weight. Aerobic and anaerobic microcosms were pre-incubated at 20 °C for 35 days and at 23 °C for 43 days, respectively. Activated sludge was added to the soil at 5 mg/g, and HBCD was added to the soil to achieve a nominal concentration of 0.025 mg/kg dry weight. The microcosms were then incubated in the dark at 20 °C for up to 120 days. The disappearance half-lives were 63 days in viable aerobic soil (compared to >120 days in abiotic aerobic controls) and 6.9 days in viable anaerobic soil (compared to 82 days in abiotic anaerobic controls). As in the sediment studies, HBCD degradation in soil occurred faster under anaerobic conditions compared to aerobic conditions, and faster in viable conditions than abiotic conditions. The disappearance half-lives in soil were slower than those in sediment.

Biological processes were suggested to be responsible for the increased degradation of HBCD in this study using viable conditions, relative to abiotic conditions; however, degradation was not adequately demonstrated in soil because no degradation products were detected and only γ -HBCD was used to quantify HBCD concentrations, making it impossible to calculate a mass balance. HBCD recoveries on day 0 of the experiment were well below (0.011–0.018 mg/kg dry weight) the nominal test concentrations (0.025 mg/kg dry weight), suggesting rapid adsorption of HBCD to soil and poor extraction methods ([NICNAS 2012a](#); [ECHA 2008b](#)).

In studies using 0.025–0.089 mg/kg HBCD ([Davis et al. 2005](#)), the estimated half-life values were shorter than studies using 3.0–4.7 mg/kg HBCD ([Davis et al. 2006](#)) by approximately one order of magnitude for aerobic, viable sediment (11–32 days compared to 72–128 days) and anaerobic viable sediment (1.1–1.5 days compared to 92 days). The viable aerobic soil half-life using lower concentrations of HBCD ([Davis et al. 2005](#)) was less than half of the half-life based on the higher HBCD concentration (63 days compared to >120 days) ([Davis et al. 2006](#)). Both Davis et al. ([Davis et al. 2006](#); [Davis et al. 2005](#)) studies suggest that HBCD degrades faster in sediment than in soil, faster under anaerobic conditions than aerobic conditions, and faster with microbial action than without microbial action. HBCD is poorly soluble, and it was suggested that at higher concentrations of HBCD, degradation is limited by mass transfer of HBCD into microbes. However, results from the Davis et al. ([2005](#)) study likely overestimate the rate of HBCD biodegradation, for the reasons noted above (primarily, failure to use ^{14}C -radiolabeled HBCD, quantify isomers other than γ -HBCD, identify degradation products, or establish a mass balance, but also procedural problems with contamination of sediment, incomplete HBCD extraction, and occurrence of an interfering peak in the LC/MS chromatograms corresponding to γ -HBCD).

Furthermore, the rapid biodegradation rates from Davis et al. ([2005](#)) are not consistent with environmental observations. HBCD has been detected over large areas and in remote locations in environmental monitoring studies. Dated sediment core samples indicate slow environmental degradation rates ([NICNAS 2012a](#); [Marvin et al. 2011](#); [ECHA 2008b](#); [Davis et al. 2005](#)). For example, HBCD was found at concentrations ranging from 112 to 70,085 $\mu\text{g}/\text{kg}$ dry weight in sediment samples collected at locations near a production site in Aycliffe, United Kingdom 2 years after the facility was closed down ([ECHA 2008b](#)). Monitoring data do not provide a complete, quantitative determination of persistence because HBCD emission sources, rates, and quantities are typically unknown, and all environmental compartments are not considered. However, the monitoring data do provide evidence in support of environmental persistence.

Rapid HBCD biodegradation has been demonstrated under laboratory conditions not representative of typical environmental conditions. A study designed to elucidate HBCD degradation mechanisms and

optimize biodegradation capability reported an HBCD degradation half-life of only 0.66 days in anaerobic digested sewage sludge amended with yeast and starch at 37 °C. In this test, α -HBCD had lower susceptibility to degradation than β - or γ -HBCD ([Gerecke et al. 2006](#)). The authors noted that these results are specific to the anaerobic conditions established by the experiment, and that the degradation rate constants are expected to vary based on redox conditions of each specific anaerobic environment.

C.2 Bioconcentration/Bioaccumulation

HBCD has been shown in numerous studies to bioaccumulate and biomagnify in aquatic and terrestrial food chains.

Bioisomerization

In general, α -HBCD bioaccumulates in organisms and biomagnifies through food webs to a greater extent than the β - and γ - diastereomers. Uncertainty remains as to the balance of diastereomer accumulation in various species and the extent to which bioisomerization and biotransformation rates for each isomer affect bioaccumulation potential. Some authors (*e.g.*, ([Law et al. 2006](#))) have proposed that γ -HBCD isomerizes to α -HBCD under physiological conditions, rather than uptake being diastereoisomer-specific. To test this theory, Esslinger et al. ([Esslinger et al. 2010](#)) exposed mirror carp (*Cyprinus carpio morpha noblis*) to only γ -HBCD and found no evidence of bioisomerization. In contrast, when Du et al. ([Du et al. 2012a](#)) exposed zebrafish (*Danio rerio*) to only γ -HBCD, they found detectable levels of α -HBCD in fish tissue, suggesting that bioisomerization occurred. Marvin et al. ([Marvin et al. 2011](#)) hypothesized that differences in accumulation could also be due in part to a combination of differences in solubility, bioavailability, and uptake and depuration kinetics.

([Zhang et al. 2014b](#)) calculated diastereomer-specific BCFs in algae and cyanobacteria ranging from 174 to 469. For the cyanobacteria (*Spirulina subsalsa*), the BCF for α -HBCD (350) was higher than the BCFs for β -HBCD (270) and γ -HBCD (174). However, for the tested alga (*Scenedesmus obliquus*), the BCF for β -HBCD (469) was higher than that for the other isomers (390 – 407).

Bioconcentration

BCFs for HBCD in fish in the peer-reviewed literature range as high as 18,100, as shown in Appendix C.2 ([Zhang et al. 2014a](#); [Wildlife Intl 2000](#); [Veith et al. 1979](#)). Drottar and Krueger (2000) provided strong evidence that HBCD bioaccumulates in a bioconcentration test that was conducted according to guidelines OECD Test Guideline (TG) 305 and Office of Prevention, Pesticides and Toxic Substances (OPPTS) 850.1730. In this study, BCFs of 13,085 and 8,974 were reported in rainbow trout (*O. mykiss*) exposed to 0.18 and 1.8 $\mu\text{g/L}$, respectively. Concentrations of HBCD in tissue reached steady-state at day 14 for fish exposed to 1.8 $\mu\text{g/L}$ and, during the subsequent depuration stage, a 50% reduction of HBCD from edible and non-edible tissue and whole fish was reported on days 19 and 20 post-exposure. In fish exposed to 0.18 $\mu\text{g/L}$, an apparent steady-state was reached on day 21, but on day 35, the tissue concentration of HBCD in fish increased noticeably; thus, steady-state was not achieved according to study authors, and BCF values (for the exposure concentration of 0.18 $\mu\text{g/L}$) were calculated based on day 35 tissue concentrations. A kinetic BCF value 14039 for the 0.18 $\mu\text{g/L}$ exposure concentration was calculated to address the possibility that steady state was not reached ([ECHA 2008b](#)). Clearance of 50% HBCD from tissue of 0.18 $\mu\text{g/L}$ exposed fish occurred 30–35 days post-exposure.

Veith et al. (1979) further supports a conclusion that HBCD bioaccumulates in a study conducted prior to the establishment of standardized testing guidelines for bioconcentration studies. The study reported a BCF of 18,100 following exposure of fathead minnow to 6.2 $\mu\text{g/L}$; the BCF was identified as a steady-

state BCF, but the report does not indicate time when steady-state was reached. A depuration phase was not included in this study. Zhang et al. (2014a) calculated BCFs for each diastereomer in mirror carp and found strong evidence that α -HBCD (BCF of 5,570–11,500) is much more bioaccumulative than β - and γ -HBCD (BCF of 187–642); BCF values that were normalized to lipid content were much higher (30,700–45,200 for α -HBCD, 1,030–1,900 for β -HBCD, and 950–1,730 for γ -HBCD) than non-normalized BCFs.

Bioaccumulation

BAFs, which capture accumulation of HBCD from diet as well as water and sediment, were calculated for freshwater food webs in industrialized areas of Southern China in two separate field studies. He et al. (He et al. 2013) calculated log BAFs of 4.8–7.7 (corresponding to BAFs of 63,000–50,000,000) for HBCD isomers in carp, tilapia, and catfish, and found higher BAFs for α -HBCD than β - and γ -HBCD. In a pond near an e-waste recycling site, Wu et al. (Wu et al. 2011) calculated log BAFs of 2.85–5.98 for Σ HBCD (corresponding to BAFs of 700–950,000) in a freshwater food web. Log BAFs for each diastereomer in this study were comparable to one another (see Appendix C.2). La Guardia et al. (La Guardia et al. 2012) calculated log BAFs in bivalves and gastropods collected downstream of a textile manufacturing outfall; these ranged from 4.2 to 5.3 for α - and β -HBCD (BAFs of 16,000–200,000), and from 3.2 to 4.8 for γ -HBCD (BAFs of 1,600–63,000).

Biota Sediment Accumulation

BSAFs calculated in studies of invertebrates and fish are generally lower than reported BCFs and BAFs. Haukås et al. (2010b) reported BSAFs ≤ 0.006 calculated from lipid-normalized concentrations of HBCD in ragworms and HBCD concentrations normalized to total organic content in sediment, indicating very low bioavailability of HBCD from sediments. Ragworm tissue concentrations were all less than the limit of detection. The pattern of diastereomers in sediments was found to generally resemble the composition of technical HBCD (*i.e.*, predominantly γ -HBCD). This study also found that in ragworms exposed to HBCD through a diet of contaminated mussels (containing diastereomer contributions of 48% α -HBCD, 7% β -HBCD, and 45% γ -HBCD), the tissue concentration of α -HBCD was greater than that of β -HBCD or γ -HBCD, suggesting selective bioaccumulation of the α -diastereomer.

Log BSAFs calculated in bivalves and gastropods collected downstream of a textile manufacturing outfall ranged from 0 to 0.9 (for α - and β -HBCD) and from -1.5 to 0 (for γ -HBCD) (La Guardia et al. 2012). These correspond to BSAFs of 1–8 for α - and β -HBCD and 0.03–1 for γ -HBCD. BSAFs in benthivorous barbell (*Barbus graellsii*) and pelagic bleak (*Alburnus alburnus*) were calculated based on measured concentrations of HBCD reported in Eljarrat et al. (2005; 2004) as cited in (van Beusekom et al. 2006) and ranged from 0.1 to 1.44 and from 0.14 to 1.23, respectively (van Beusekom et al. 2006).

Biomagnification of HBCD was demonstrated by Law et al. (2006), who reported BMFs of 9.2 (α -HBCD), 4.3 (β -HBCD), and 7.2 (γ -HBCD). Uptake of HBCD into muscle from the diet of rainbow trout was exponential for α -HBCD with a doubling time of 8.2 days, exponential for β -HBCD with a doubling time of 17.1 days, and linear for γ -HBCD with a rate constant of 0.006 per day. Depuration was rapid during the first 14 days and slower for the remainder of the experiment for α -HBCD (overall depuration rate was not determined). Depuration rates of 0.44×10^{-2} and 0.48×10^{-2} per day were found for β -HBCD and γ -HBCD, respectively. Steady-state was not reached for any of the diastereomers within the 52-day exposure period.

Biomagnification

Additional studies are available that support the conclusion that HBCD has the potential to biomagnify. Studies of zebrafish by Du et al. (Du et al. 2013; Du et al. 2012a) reported diastereo- and enantiomer-

specific biomagnification. When BMFs were calculated for diastereomers without accounting for specific enantiomers, after 42 days of exposure and a 21-day depuration period, α -HBCD was shown to biomagnify to a greater extent than β - and γ -HBCD (maximum BMFs of 29.71, 11.63, and 7.76, respectively). Enantiomer-specific BMFs calculated in zebrafish by Du et al. (2013) followed a similar diastereomer pattern, although the BMF values were much lower than those from Du et al. (2012a). Additionally, the results of Du et al. (2013) suggest that the (+) enantiomers of β - and γ -HBCD are selectively magnified compared to their (-) enantiomers. This pattern did not hold true for α -HBCD.

Letcher et al. (2009) found evidence of biomagnification of HBCD from the ringed seal to the polar bear in an East Greenland food web, reporting a BMF of 1.7. BMFs for α -HBCD in a harbor seal food web varied according to prey fish species, but ranged from 0.54 to 3.0 (Shaw et al. 2012). Shaw et al. (2012) calculated higher BMFs from prey fish to the livers of adult male harbor seals than to the blubber of those seals.

BMFs for α -HBCD in gulls and common eiders in a coastal marine food web in Norway provide evidence of biomagnification, ranging from 3.1 to 1,285 when calculated on a wet weight basis and from 2.8 to 26 when calculated on a lipid-weight basis (Haukås et al. 2010a). In terrestrial food webs in China, both Sun et al. (2012) and Yu et al. (2013) found evidence of biomagnification (see Appendix C.2), with BMFs up to 30 in passerine birds and up to 16 in owls. Yu et al. (2013) found more (-) α -HBCD in predator species than (+) α -HBCD, but other studies do not agree, suggesting that enantiomer biomagnification may be species-specific.

Trophic Transfer/Trophic Magnification

Tomy et al. (2008) describes the extent of trophic transfer (transfer and accumulation of HBCD between trophic levels) by calculating TMFs of 2.1 and 0.5 for α - and γ -HBCD, respectively, based on the Arctic marine food web. Samples of blubber were taken and analyzed from the beluga whale (*Delphinapterus leucas*), narwhal (*Monodon monoceros*), and walrus (*Odobenus rosmarus*), while whole organisms were analyzed for arctic cod (*Boreogadus saida*), shrimp (*Pandalus borealis* and *Hymenodora glacialis*), clams (*Mya truncate* and *Serripes groenlandica*), deepwater redfish (*Sebastes mentella*), and mixed zooplankton to determine HBCD concentrations in the tissue of animals of different trophic levels in order to establish whether HBCD biomagnifies between trophic levels.

Brandsma et al. (2015) studied trophic magnification of HBCD through benthic and pelagic food webs in the Western Scheldt estuary, The Netherlands, and found similar results: α -HBCD concentrations increased and γ -HBCD concentrations decreased with an increase in trophic level (TMFs of 2.2 and 0.3, respectively). In a freshwater food web studied near an e-waste recycling site in South China, Wu et al. (2010) calculated enantiomer-specific TMFs for α -HBCD of 2.18–2.2, and found evidence that as HBCD migrates up through the food web, α -HBCD increases and γ -HBCD decreases, while β -HBCD comprises a very low proportion of Σ HBCD. This pattern, also demonstrated by data in Haukås et al. (2010a), becomes more prominent at upper trophic levels. In marine and freshwater food webs, Zhang et al. (2013) calculated TMFs greater than 1 for α -HBCD and Σ HBCD.

In summary, while HBCD has been shown in numerous studies to bioaccumulate and biomagnify in aquatic and terrestrial food chains, diastereomer- and enantiomer-specific mechanisms of accumulation are still unclear.

C.3 Calculation of Lipid Normalized Bioaccumulation Factors for HBCD

The lipid normalized bioaccumulation factors were calculated for:

- He et al. (2013) using mean concentration for total HBCDs in field collected Nile tilapia and Plecostomus expressed as lipid weight and total HBCD concentrations in the dissolved phase in water.

The lipid normalized BAF calculations are presented below where:

$$\text{BAF} = C_B/C_{WD}$$

C_B = chemical concentration in the organism (g/kg LW)

C_{WD} = freely dissolved chemical concentration in the water (g/L)

Sample	Mean concentration total HBCDs	Conversion	BAF
Nile tilapia	92 ng/g lw	$C_B = 9.2e-5$ g/kg	2.32E6
Plecostomus	361 ng/g lw	$C_B = 0.000361$ g/kg	9.09E6
Mud carp	58.3 ng/g lw	$C_B = 5.83e-5$ g/kg	1.47E6
Water, dissolved phase	39.7 pg/L	$C_{WD} = 3.97e-11$ g/L	n/a

Underlying data:

Table 1

Concentrations of TBBPA and HBCDs in sediment, sediment cores, water, and fish in the Dongjiang River, South China.

	Sediment (ng/g dw)	Sediment cores (ng/g dw)		Water		Fish (ng/g lw)		
	<i>N</i> = 42	Core 1 <i>N</i> = 19	Core 2 <i>N</i> = 19	Dissolved phase <i>N</i> = 5 (pg/L)	Particulate phase <i>N</i> = 5 (ng/g dw)	Mud carp <i>N</i> = 9	Nile tilapia <i>N</i> = 15	Plecostomus <i>N</i> = 10
Lipid (%)								
TBBPA	15.2 (nd–82.3)	91.6 (7.9–450)	2.9 (0.2–14)	1750 (1110–2830)	1.3 (nd ^a –1.6) ^b	2.7 (1.2–4.7)	3.7 (1.6–9.0)	3.2 (1.8–5.7)
α -HBCD	0.94 (nd–3.3)	1.8 (0.2–8.2)	0.8 (0.2–2.1)	16.0 (7.5–27.6)	3.9 (nd–3.9)	35.2 (6.5–66)	18.1 (nd–51)	21.2 (nd–53.4)
β -HBCD	0.33 (nd–2.2)	0.5 (0.1–2.2)	0.3 (0.1–0.6)	4.3 (nd–7.1)	0.9 (nd–0.9)	47.3 (17.5–114)	83.6 (nd–361)	353 (nd–825)
γ -HBCD	5.7 (0.06–28.9)	6.2 (0.8–42.8)	4.2 (0.3–20.5)	25.2 (nd–54.6)	6.8 (nd–11.3)	3.6 (nd–6.7)	5.6 (nd–19.5)	6.2 (nd–9.2)
Σ HBCD	6.9 (0.07–31.6)	8.5 (0.5–53.1)	5.3 (1.2–22.6)	39.7 (9.5–82.4)	8.0 (nd–11.3)	12.6 (nd–33.4)	63 (nd–11.4)	6.5 (nd–10.4)
						58.3 (17.5–154)	92 (nd–391)	361 (nd–832)

^a Non detected.

^b Mean (range).

Wu et al. (2010) using mean concentration for total HBCDs in field collected mud carp and Northern snakehead expressed as lipid weight and total HBCD concentrations in the dissolved phase in water.

Sample	Mean concentration total HBCDs	Conversion	BAF
Mud Carp	868 ng/g lw	$C_B = 0.000868 \text{ g/kg}$	1.45E7
Northern Snakehead	187 ng/g lw	$C_B = 0.000187 \text{ g/kg}$	3.12E6
Water, dissolved phase	0.06 ng/L	$C_{WD} = 6e-11 \text{ g/L}$	n/a

Underlying data:

TABLE 1. Concentrations of HBCDs and Other Non-PBDE Brominated Flame Retardants in the Aquatic Species (ng/g lipid), Dissolved Phase of Water (ng/L), and Sediment (ng/g wet wt) from an E-waste Recycling Site, South China

	Chinese mysterysnail <i>n</i> = 43, [3] ^a	prawn <i>n</i> = 7, [3]	mud carp <i>n</i> = 12, [8]	cruciancarp <i>n</i> = 18, [7]	northern snakehead <i>n</i> = 6	water snake <i>n</i> = 2	water <i>n</i> = 6, [3]	sediment <i>n</i> = 6, [3]
lipid (%)	0.59 ± 0.11 ^b	2.39 ± 0.32	2.87 ± 0.41	3.63 ± 0.71	1.49 ± 0.31	1.06 ± 0.15		
α-HBCD	7.73 ± 1.83	267 ± 80.9	649 ± 228	102 ± 32.8	168 ± 82.4	494 ± 315	0.05 ± 0.01	61.4 ± 10.2
β-HBCD	0.24 ± 0.24	10.2 ± 2.74	24.5 ± 9.48	5.42 ± 3.39	3.12 ± 1.76	8.76 ± 6.22	bdl ^c	23.5 ± 1.07
γ-HBCD	5.90 ± 1.25	118 ± 29.3	195 ± 66.9	21.1 ± 8.83	16.6 ± 9.06	64.0 ± 42.8	0.01 ± 0.00	84.3 ± 4.22
ΣHBCDs ^d	13.9 ± 2.61	395 ± 94.5	868 ± 280	129 ± 44.3	187 ± 92.7	567 ± 364	0.06 ± 0.01	169 ± 12.1
BTBPE	67.1 ± 36.4	44.7 ± 8.04	518 ± 277	323 ± 315	1.71 ± 1.11	9.22 ± 9.22	0.02 ± 0.01	4554 ± 608
DBDPE	bdl	84.3 ± 84.3	338 ± 171	14.0 ± 14.0	bdl	bdl	bdl	1796 ± 770
HBB	298 ± 51.3	197 ± 53.4	2451 ± 778	680 ± 158	1153 ± 470	3099 ± 2809	0.52 ± 0.04	8672 ± 1053
PBEB	14.3 ± 2.53	6.35 ± 2.52	25.6 ± 11.1	3.98 ± 2.10	17.5 ± 5.53	4.14 ± 4.14	0.06 ± 0.00	132 ± 6.12
PBT	3.60 ± 0.90	1.55 ± 0.64	3.24 ± 1.51	1.59 ± 0.45	1.20 ± 0.57	106 ± 103	0.03 ± 0.01	20.6 ± 2.89
BDE 47 ^e	4270 ± 820	4640 ± 1330	20910 ± 3740	5860 ± 1480	25960 ± 4020	51870 ± 29940	10.7 ± 0.14	44130 ± 717

^a Numer of individual samples collected, figures in brackets indicate analyses number of pooled samples when individuals were pooled. ^b Mean ± SE. ^c Below the detection limit. ^d total HBCDs. ^e Data from ref 30 given for comparison.

The concentration of a chemical in an organism can be expressed based on several different measurements: wet weight (WW), dry weight (DW) or lipid weight (LW). Lipid normalizing is a method of expressing the chemical concentration on a lipid weight basis by dividing the WW chemical concentration by the lipid fraction of the measured sample.

$$\text{BAF}_{\text{LW}} = \frac{\text{BAF}_{\text{WW}}}{\text{lipid fraction}}$$

Appendix D RELEASES TO THE ENVIRONMENT

D.1 2017 TRI Releases Not Used in this Assessment

Table_Apx D-1. presents 2017 TRI data that was not used in this assessment. These HBCD release data were reported by Flame Control Coatings, LLC for one site that previously used HBCD as a component in flame retarded coatings. These TRI releases were not used in the assessment because Flame Control Coatings, LLC has indicated that they have ceased use of HBCD and the use of coatings is not an exposure scenario in this final Risk Evaluation, as discussed in Section 1.2.4 of this final Risk Evaluation.

Table_Apx D-1. 2017 TRI Data Not Used in this Assessment

Site Identity	Reported NAICS Code - Meaning	Function Inferred from Communication with Company	Annual HBCD Release per Site (kg/site-year)
Flame Control Coatings, LLC, Niagara NY	325510 - Paint and Coating Manufacturing	Flame retardant in architectural coatings	<u>Fugitive air ^a: 0.612</u> <u>Stack air ^b: 5.505</u>
<p>^a These fugitive air releases were reported under Section 5.1 of the TRI Form R, which correspond to on-site fugitive or non-point air emissions.</p> <p>^b These stack air releases were reported under Section 5.2 of the TRI Form R, which correspond to on-site stack or point air emissions.</p>			

D.2 Evaluation of Environmental Release Data Sources

EPA has reviewed acceptable sources for HBCD release data according to the data quality evaluation criteria found in [The Application of Systematic Review in TSCA Risk Evaluations](#) (U.S. EPA 2018b). Table_Apx D-2 summarizes the results of this evaluation. The data quality evaluation indicated the release sources included are of medium to high confidence and are used to characterize releases of HBCD.

Table_Apx D-2. Summary of Release Data and Systematic Review Results

Row	Exposure scenario	Release Data from Source		Source	Data Identifier from Data Extraction and Evaluation (DEE)	Overall Confidence Rating from DEE	Rationale for Inclusion / Exclusion
		Identifier	Release				
1	Compounding of Polystyrene Resin to Produce XPS Masterbatch	Site 1	Water: 0.12 kg HBCD/yr Air: 2.6 kg HBCD/yr	(ECHA 2008b)	3970747	High	Included - EPA calculated emission factors from these data and used them to estimate releases in the corresponding exposure scenario
2	Compounding of Polystyrene Resin to Produce XPS Masterbatch	Site 2	Water: 0.27 kg HBCD/yr Air: 1.2 kg HBCD/yr	(ECHA 2008b)	3970747	High	
3	Compounding of Polystyrene Resin to Produce XPS Masterbatch	Site 3	Water: 37 kg HBCD/yr Air: 3.3 kg HBCD/yr	(ECHA 2008b)	3970747	High	
4	Manufacturing of XPS Foam using XPS Masterbatch	Site 1	Water: 2.2 kg HBCD/yr Air: 0.31 kg HBCD/yr	(ECHA 2008b)	3970747	High	Included - EPA calculated emission factors from these data and used them to estimate releases in the corresponding exposure scenario
5	Manufacturing of XPS Foam using XPS Masterbatch	Site 2	Water: 0 kg HBCD/yr Air: 18 kg HBCD/yr	(ECHA 2008b)	3970747	High	
6	Manufacturing of XPS Foam using XPS Masterbatch	Site 3	Water: 1.3 kg HBCD/yr Air: 14 kg HBCD/yr	(ECHA 2008b)	3970747	High	
7	Manufacturing of XPS Foam using XPS Masterbatch	Site 4	Water: 4.2 kg HBCD/yr Air: 9.3 kg HBCD/yr	(ECHA 2008b)	3970747	High	
8	Manufacturing of XPS Foam using XPS Masterbatch	Calculated Site Estimate - reported by EURAR as worst-case emission factor derived from site-specific data	Water: 7.9 kg HBCD/yr Air: 17.4 kg HBCD/yr	(ECHA 2008b)	3970747	High	
9	Manufacturing of XPS Foam using HBCD Powder	Site 1	Water: 4.4 kg HBCD/yr Air: 1.5 kg HBCD/yr	(ECHA 2008b)	3970747	High	
10	Manufacturing of XPS Foam using HBCD Powder	Site 2	Water: 1.2 kg HBCD/yr Air: 1.4 kg HBCD/yr	(ECHA 2008b)	3970747	High	
11	Manufacturing of XPS Foam using HBCD Powder	Site 3	Water: 0.055 kg HBCD/yr Air: 3.7 kg HBCD/yr	(ECHA 2008b)	3970747	High	
12	Manufacturing of XPS Foam using HBCD Powder	Site 4	Water: 3.7 kg HBCD/yr Air: 1.5 kg HBCD/yr	(ECHA 2008b)	3970747	High	Included - EPA calculated emission factors from these data and used them to estimate releases in the corresponding exposure scenario
13	Manufacturing of XPS Foam using HBCD Powder	Site 5	Water: 0.0024 kg HBCD/yr Air: 1.1 kg HBCD/yr	(ECHA 2008b)	3970747	High	
14	Manufacturing of XPS Foam using HBCD Powder	Site 6	Water: 0 kg HBCD/yr Air: 0.73 kg HBCD/yr	(ECHA 2008b)	3970747	High	
15	Manufacturing of XPS Foam using HBCD Powder	Site 7	Water: 6 kg HBCD/yr Air: 0.54 kg HBCD/yr	(ECHA 2008b)	3970747	High	
16	Manufacturing of XPS Foam using HBCD Powder	Site 8	Water: 0.0029 kg HBCD/yr Air: 0.7 kg HBCD/yr	(ECHA 2008b)	3970747	High	

Row	Exposure scenario	Release Data from Source		Source	Data Identifier from Data Extraction and Evaluation (DEE)	Overall Confidence Rating from DEE	Rationale for Inclusion / Exclusion
		Identifier	Release				
17	Manufacturing of XPS Foam using HBCD Powder	Site 9	Water: 0.0019 kg HBCD/yr Air: 0.15 kg HBCD/yr	(ECHA 2008b)	3970747	High	
18	Manufacturing of XPS Foam using HBCD Powder	Site 10	Water: 0 kg HBCD/yr Air: 0.4 kg HBCD/yr	(ECHA 2008b)	3970747	High	
19	Manufacturing of XPS Foam using HBCD Powder	Site 11	Water: 0 kg HBCD/yr Air: 1.8 kg HBCD/yr	(ECHA 2008b)	3970747	High	
20	Manufacturing of XPS Foam using HBCD Powder	Site 12	Water: 0 kg HBCD/yr Air: 1.8 kg HBCD/yr	(ECHA 2008b)	3970747	High	
21	Manufacturing of XPS Foam using HBCD Powder	Site 13	Water: 0.11 kg HBCD/yr Air: 1.2 kg HBCD/yr	(ECHA 2008b)	3970747	High	
22	Manufacturing of XPS Foam using HBCD Powder	Site 14	Water: 15 kg HBCD/yr Air: 1.5 kg HBCD/yr	(ECHA 2008b)	3970747	High	
23	Manufacturing of XPS Foam using HBCD Powder	Site 15	Water: 0.00004 kg HBCD/yr Air: 0.59 kg HBCD/yr	(ECHA 2008b)	3970747	High	
24	Manufacturing of XPS Foam using HBCD Powder	Site 16	Water: 0.0004 kg HBCD/yr Air: 0.91 kg HBCD/yr	(ECHA 2008b)	3970747	High	
25	Manufacturing of XPS Foam using HBCD Powder	Site 17	Water: 0.021 kg HBCD/yr Air: 3.8 kg HBCD/yr	(ECHA 2008b)	3970747	High	
26	Manufacturing of XPS Foam using HBCD Powder	Site 18	Water: 2.5 kg HBCD/yr Air: 0.23 kg HBCD/yr	(ECHA 2008b)	3970747	High	
27	Manufacturing of XPS Foam using XPS Masterbatch; Manufacturing of XPS Foam using HBCD Powder; Manufacturing of EPS Foam from Imported EPS Resin Beads	Dow Chemical Company, Pevely MO	Stack air: 1.81 kg HBCD/yr Off-site transfer for Incineration/thermal treatment: 30.8 kg HBCD/yr Off-site M64, off-site transfer for disposal to other landfills: 123 kg HBCD/yr	(U.S. EPA 2017g)	2017 TRI	Medium	Included - per the company, operations with HBCD have ceased. Data is used as surrogate for unidentified site
28	Manufacturing of XPS Foam using XPS Masterbatch; Manufacturing of XPS Foam using HBCD Powder; Manufacturing of EPS Foam from Imported EPS Resin Beads	Dow Chemical Company, Dalton GA	Stack air: 21.3 kg HBCD/yr Off-site M64, off-site transfer for disposal to other landfills: 109 kg HBCD/yr Off-site M56, off-site transfer for Energy Recovery: 23.1 kg HBCD/yr	(U.S. EPA 2017g)	2017 TRI	Medium	Included - per the company, operations with HBCD have ceased. Data is used as surrogate for unidentified site
29	Manufacturing of SIPs and Automobile Replacement Parts from XPS/EPS Foam; Installation of XPS/EPS	XPS Boards	5 g XPS particles/metric ton XPS sawed	(ECHA 2008b)	3970747	High	Included - emission factors were used in the corresponding

Row	Exposure scenario	Release Data from Source		Source	Data Identifier from Data Extraction and Evaluation (DEE)	Overall Confidence Rating from DEE	Rationale for Inclusion / Exclusion
		Identifier	Release				
	Foam Insulation in Residential, Public and Commercial Buildings, and Other Structures						exposure scenarios
30	Manufacturing of SIPs and Automobile Replacement Parts from XPS/EPS Foam; Installation of XPS/EPS Foam Insulation in Residential, Public and Commercial Buildings, and Other Structures	EPS Boards	445 g EPS particles/metric ton EPS sawed	(ECHA 2008b)	3970747	High	
31	Manufacturing of SIPs and Automobile Replacement Parts from XPS/EPS Foam; Installation of XPS/EPS Foam Insulation in Residential, Public and Commercial Buildings, and Other Structures	EPS Boards	100 g EPS particles/metric ton EPS cut	(ECHA 2008b)	3970747	High	
32	Demolition and Disposal of XPS/EPS Foam Insulation Products in Residential, Public and Commercial Buildings, and Other Structures	Manual breaking of EPS boards	90 g EPS particles/metric ton EPS broken	(ECHA 2008b)	3970747	High	Included - emission factor was used in corresponding exposure scenario
33	Demolition and Disposal of XPS/EPS Foam Insulation Products in Residential, Public and Commercial Buildings, and Other Structures	Manual breaking of XPS boards	0 g XPS particles/metric ton XPS broken	(ECHA 2008b)	3970747	High	Included - emission factor was used in corresponding exposure scenario
34	Formulation of Coatings	Flame Control Coatings LLC, Niagara NY	Fugitive air: 0.612 kg HBCD/yr Stack air: 5.505 kg HBCD/yr	(U.S. EPA 2017g)	2017 TRI	Medium	Excluded – this data is presented in Appendix D.1, but this is not an exposure scenario
35	Formulation of Solder/Flux Pastes	Indium Corporation of America, Clinton, NY	Fugitive air: 0.454 kg HBCD/yr Stack air: 6.350 kg HBCD/yr Waste broker for disposal: 0.454 kg HBCD/yr	(U.S. EPA 2017g)	2017 TRI	Medium	Included - loss quantity was used in the

Row	Exposure scenario	Release Data from Source		Source	Data Identifier from Data Extraction and Evaluation (DEE)	Overall Confidence Rating from DEE	Rationale for Inclusion / Exclusion
		Identifier	Release				
			Treatment via solidification/stabilization: 6.350 kg HBCD/yr				corresponding exposure scenario

Appendix E OCCUPATIONAL EXPOSURES

E.1 Inhalation Monitoring Data Summary

This appendix contains a summary of the available data that EPA compiled from literature sources.

EPA compiled HBCD inhalation monitoring data that was available in literature into three tables based on the associated worker activities:

- Table_Apx E-1 contains inhalation monitoring data related to the handling of HBCD in various forms, including fine grade powder, standard grade powder, and granules.
- Table_Apx E-2 contains inhalation monitoring data related to the handling and processing of XPS and EPS foam containing HBCD.

Table_Apx E-1. Inhalation Monitoring Data for Handling of HBCD

Literature Study ^a	Exposure scenario	Form of HBCD Handled	Type of Sample	Worker Activity or Sampling Location	Exposure Concentration (mg/m ³) ^b	Number of Samples	Sample Time / Type of Measurement ^c	Source	Overall Confidence Rating
Searl and Robertson (2005) - 1a	Manufacturing of HBCD	Standard grade HBCD	Personal Breathing Zone	Packaging, compaction, process operations, and working in the warehouse	Mean: 1.23 Median: 0.89 90th percentile: 1.89 Max: 3 mg/m ³	10	8-hr TWA	(ECHA 2008b) (ECHA 2009b)	High
Searl and Robertson (2005) - 1b	Manufacturing of HBCD	Fine grade HBCD	Personal Breathing Zone	Packaging, compaction, process operations, and working in the warehouse	Mean: 23 90th percentile: 35	4	8-hr TWA	(ECHA 2008b)	High
Searl and Robertson (2005) - 1c	Manufacturing of HBCD	HBCD of unknown grade	NR	Packaging and compaction of powders	Respirable, mean: 0.18 Inhalable, Mean: 1.23	NR	NR	(ECHA 2009c)	High
Waindzioch (2000) - 1a	Manufacturing of HBCD	HBCD of unknown grade	Area	Reactor	0.00028 - 0.0285	3	Short-term	(ECHA 2008b)	Unacceptable
Waindzioch (2000) - 1b	Manufacturing of HBCD	HBCD of unknown grade	Area	Filling Station	0.0094 - 0.097	2	Short-term	(ECHA 2008b)	High
Bieseimer (1996)	Manufacturing of HBCD	HBCD of unknown grade	NR	Bagging HBCD product	4.0 - 4.5	NR	NR	(ECHA 2008b)	High
Velsicol (1978)	Manufacturing of HBCD	HBCD of unknown grade	Personal Breathing Zone	Transfer of the HBCD in the hammer-mill to 28 drums	1.9	1	300 minutes	(Velsicol Chem Corp 1978)	High
Yi et al. (2016)	Manufacturing of HBCD	HBCD of unknown grade	Personal Breathing Zone	NR	0.0102 - 0.0283	14	NR	(Yi et al. 2016)	High
Searl and Robertson (2005) - 2a	Manufacturing of EPS Resin beads	Standard grade HBCD	Personal	Manual addition of HBCD powder to reactor each time a batch of EPS resin was produced	Range: 2.89-21.5 Mean: 7.2 Median: 5.52	12	Short-term (13 to 56 mins)	(NICNAS 2012b); (ECHA 2008b)	High

Literature Study ^a	Exposure scenario	Form of HBCD Handled	Type of Sample	Worker Activity or Sampling Location	Exposure Concentration (mg/m ³) ^b	Number of Samples	Sample Time / Type of Measurement ^c	Source	Overall Confidence Rating
					90th percentile: 10.5				
Searl and Robertson (2005) - 2b	Manufacturing of EPS Resin beads	Standard grade HBCD	Personal	Manual addition of HBCD powder to reactor each time a batch of EPS resin was produced	Range: 0.12-3.36 Mean: 1 Median: 0.42 90th percentile: 1.11 (NICNAS 2012b); 1.3 (ECHA 2008b)	12	8-hr TWA – note these are 8-hr TWA values of the data in the above row	(NICNAS 2012b); (ECHA 2008b)	High
Searl and Robertson (2005) - 2c	Manufacturing of EPS Resin beads	Standard grade HBCD	Personal	Manual addition of HBCD powder to reactor each time a batch of EPS resin was produced	Range: 0.07-14.7 Mean: 1.2 Median: 0.27 90th percentile: 1.10	18	8-hr TWA (ECHA 2008b); 275 to 504 mins (NICNAS 2012b)	(NICNAS 2012b); (ECHA 2008b)	High
Searl and Robertson (2005) - 2d	Manufacturing of EPS Resin beads	Standard grade HBCD	Personal	Weighing powder prior to addition to reactor. HBCD bags were weighed and opened concurrently, or weighed in advance, in which case HBCD was transferred from 25-kg sacks using plastic scoop (full-shift measurement).	Range: 4.35-12.1 Mean: 7.2 Median: 6.19 90th percentile: 10.5 (NICNAS 2012b); 10.5 & 10.6 (ECHA 2008b)	4	8-hr TWA (ECHA 2008b); 124 to 350 mins (NICNAS 2012b)	(NICNAS 2012b); (ECHA 2008b)	High
Searl and Robertson (2005) - 3a	Compounding of Polystyrene resin to produce XPS Masterbatch containing HBCD	HBCD of unknown grade	Area	Weighing and mixing	Max 7.5 (for 2 hours) Mean: 1.89 Median: 0.83 90th percentile: 5.4	10	Short-term	(ECHA 2008b), (ECHA 2009b)	High

Literature Study ^a	Exposure scenario	Form of HBCD Handled	Type of Sample	Worker Activity or Sampling Location	Exposure Concentration (mg/m ³) ^b	Number of Samples	Sample Time / Type of Measurement ^c	Source	Overall Confidence Rating
Searl and Robertson (2005) - 3b	Compounding of Polystyrene resin to produce XPS Masterbatch containing HBCD	HBCD of unknown grade	Area	Weighing and mixing	Mean: 0.88 90th percentile: 1.36	10	8-hr TWA	(ECHA 2008b)	High
Searl and Robertson (2005) - 3c	Compounding of Polystyrene resin to produce XPS Masterbatch containing HBCD	HBCD of unknown grade	NR	Extruder	Mean: 0.12 Median: 0.10 90th percentile: 0.16	4	5 hours	(ECHA 2008b), (ECHA 2009b)	High
Searl and Robertson (2005) - 3d	Compounding of Polystyrene resin to produce XPS Masterbatch containing HBCD	HBCD of unknown grade	NR	Automated handling of HBCD	Negligible	3	NR	(ECHA 2008b)	High
Abbott (2001) - 1a	Manufacture of XPS from HBCD powder or granules	Standard grade HBCD	Area	At the feed deck near typical operator positions	Range 0.24 – 1.6 Mean: 0.66 90th percentile: 1.45 (excluding 10 ND samples)	16 (10 ND)	8-hr TWA	(ECHA 2008b)	High
Abbott (2001) - 1b	Manufacture of XPS from HBCD powder or granules	HBCD granules	Mostly area and some personal breathing zone	Feed deck near typical operator positions	Range 0.005-0.9 Mean: 0.24 90th percentile: 0.47	43 (16 ND)	60 – 1435 minutes	(ECHA 2008b)	High

Literature Study ^a	Exposure scenario	Form of HBCD Handled	Type of Sample	Worker Activity or Sampling Location	Exposure Concentration (mg/m ³) ^b	Number of Samples	Sample Time / Type of Measurement ^c	Source	Overall Confidence Rating
					(excluding 16 ND samples)				
Thomsen (2007) - 1a	Manufacture of XPS from HBCD powder or granules	HBCD powder and granules	Personal breathing zone	Activities in the mixer area, including operating a closed automated process excluding potential contact with neat HBCD	Range: 0.0002-0.0009 Mean: 0.0005 Median: 0.0005	6	8-hr TWA	(ECHA 2008b) (NICNAS 2012b)	High
Thomsen (2007) - 1b	Manufacture of XPS from HBCD powder or granules	HBCD powder and granules	Personal breathing zone	Weighing and addition of HBCD to the reactor and subsequent washing, centrifugation, sifting, and transfer of product to a silo container	Range: 0.001-0.15 Mean: 0.015 Median: 0.0027	24	8-hr TWA	(ECHA 2008b) (NICNAS 2012b)	High
Searl and Robertson (2005) - 4	Manufacture of XPS from HBCD powder or granules	HBCD granules	Area	Logistics, extruding, and laboratory	Mean: 0.00003 90th percentile: 0.00004	12	8-hr TWA	(ECHA 2008b)	High
Ransbotyn (2000)	Manufacturing of EPS Resin beads	Respirable Dust Inhalable Dust	Personal	Addition of HBCDD to reactor or the supervising of the addition.	Respirable dust: <0.5 Total Inhalable dust: 2.0 Not specific to HBCD	5	Max 8-hr TWA	(ECHA 2008b)	High
NICNAS (2012b) - 1a	All industrial polymer processing sites	Standard grade HBCD	Modelled with EASE	Addition of HBCD into process operation	Typical: 2 to 5 Worst-case: 5 to 50	N/A - this is a modelled exposure	8-hr TWA	(NICNAS 2012b)	High
NICNAS (2012b) - 1b	HBCD importation / repackaging sites and all industrial polymer processing sites	HBCD granules	Modelled with EASE	Repackaging with the use of LEV (typical) and without LEV (worst-case)	Typical: 0.2 to 0.5 Worst-case: 0.5 to 5	N/A - this is a modelled exposure	8-hr TWA	(NICNAS 2012b)	High

NR = Not Reported; N/A = Not Applicable

a – Where multiple datasets were available from one literature source, EPA distinguished data as 1a, 1b, 2a, 2b, etc.

b - Statistics were calculated by the cited source and are presented here as they were presented in the source.

c – Where information is presented in multiple sources all sources are listed. Information was not combined from these sources but was presented in all sources independently.

Table_Apx E-2. Inhalation Monitoring Data For Handling of XPS and EPS Foam Containing HBCD

Literature Study ^a	Exposure scenario	Form of HBCD Handled	Type of Sample	Worker Activity or Sampling Location	Exposure Concentration (mg/m ³) ^b	Number of Samples	Sample Time / Type of Measurement	Source ^c	Overall Confidence Rating
Searl and Robertson (2005) - 5a	Manufacture of XPS from XPS Masterbatch	XPS foam	NR	Secondary processing of XPS foam - including cutting, sawing, and machining to manufacture shaped products	Mean: 0.08 90th percentile: 0.22 ^d	9	8-hr TWA	Original source: Searl and Robertson (2005) Reported in: (ECHA 2008b); (ECHA 2009b)	High
Searl and Robertson (2005) - 5b	Manufacture of XPS from XPS Masterbatch	XPS foam	NR	Reclamation of XPS foam - including shredding and reprocessing of process waste	Mean: 0.02 90th percentile: 0.02 ^d	5	8-hr TWA	Original source: Searl and Robertson (2005) Reported in: (ECHA 2008b); (ECHA 2009b)	High
Searl and Robertson (2005) - 5c	Manufacture of XPS from XPS Masterbatch	XPS foam	NR	Other process control operators	Mean: 0.03 90th percentile: 0.03 ^d	4	8-hr TWA	Original source: Searl and Robertson (2005) Reported in: (ECHA 2008b); (ECHA 2009b)	High

Literature Study ^a	Exposure scenario	Form of HBCD Handled	Type of Sample	Worker Activity or Sampling Location	Exposure Concentration (mg/m ³) ^b	Number of Samples	Sample Time / Type of Measurement	Source ^c	Overall Confidence Rating
Searl and Robertson (2005) - 5d	Manufacture of XPS from XPS Masterbatch	XPS foam	NR	Process operators handling XPS masterbatch	Mean: 0.03 90th percentile: 0.03 ^d	24	8-hr TWA	Original source: Searl and Robertson (2005) Reported in: (ECHA 2008b); (ECHA 2009b)	High
Zhang et al. (2012) - 1a	Thermal cutting of XPS boards	XPS foam	NR	Thermal cutting of XPS boards in a closed glovebox	Mean: 0.089	NR	NR	(Zhang et al. 2012)	High
Zhang et al. (2012) - 1b	Thermal cutting of EPS boards	EPS foam	NR	Thermal cutting of EPS boards in a closed glovebox	Mean: 0.057	NR	NR	(Zhang et al. 2012)	High

NR = Not Reported

a – Where multiple datasets were available from one literature source, EPA distinguished data as 1a, 1b, 2a, 2b, etc.

b – Statistics were calculated by the cited source and are presented here as they were presented in the source.

c – Where information is presented in multiple sources all sources are listed. Information was not combined from these sources but was presented in all sources independently.

d – These exposure values were all originally reported in the same study, Searl and Robertson (2005), and discussed in the EURAR (ECHA 2008b) and an ECHA report (ECHA 2009b). The dataset includes 42 total samples, taken at three XPS manufacturing sites in the EU. The EURAR reports that the first two rows, consisting of 14 total data points, include all non-detects, except for three samples, indicating that the exposure potential during these activities is low, despite the fact that the exposure concentrations in Searl and Robertson (2005) – 5a are the highest of the surveyed activities.

E.2 Summary of Other Assessment Approaches

EPA identified three HBCD risk assessments from other countries. These include:

- European Union (EU) – Risk Assessment, Hexabromocyclododecane ([ECHA 2008b](#))
- Australian Government Department of Health and Ageing, National Industrial Chemicals Notification and Assessment Scheme (NICNAS) – Priority Existing Chemical Assessment Report No. 34, Hexabromocyclododecane ([NICNAS 2012b](#))
- Environmental Canada (EC), Health Canada – Screening Assessment Report on Hexabromocyclododecane ([EC/HC 2011](#))
 - Note that this RAR only includes release assessments during raw materials handling and compounding and does not assess occupational exposures.

EPA compiled the assessment approaches from the above three sources for each exposure scenario assessed in this assessment below. Table_Apx E-3 and Table_Apx E-4 specifically list the inhalation exposure assessment methodology in the EU and NICNAS RARs, respectively. lists methodology for oral and dermal exposure, as well as environmental release assessment methodology.

Table_Apx E-3. Summary of HBCD Occupational Inhalation Exposure Assessment Results and the Associated Assessment Basis and Assessment Approach that are Reported in EU (2008)

Assessment Parameter				
Chemical Process: Manufacture of HBCD				
Exposure Concentration	HBCD standard grade powder	RWC: 1.9 mg/m ³	The basis is the worker exposure monitoring data for the manufacture of HBCD that are reported in Searl and Robertson (2005) - 1a of Table_Apx E-1 of this report.	The RWC exposure concentration was assessed to be equal to the 90 th percentile of the concentration measurements referenced under Basis. Typical exposure concentration: refer to footnote (1).
		Typical: 0.95 mg/m ³	The rationale is that this is the only worker exposure monitoring data for HBCD manufacturing that is specifically associated with the HBCD standard grade powder product.	
Exposure Concentration	HBCD granules	RWC: 0.19 mg/m ³	This data were also used as the basis for the assessment of exposure concentrations in the case of the HBCD granules product.	The typical exposure concentration was assumed to be equal to 10 percent of the RWC exposure concentration that was assessed in the case of the HBCD standard grade powder product. The rationale for this assumption is that 10 percent of particles in the HBCD granules product were assumed to have a size of less than 100 µm, which is the assumed maximum particle size for HBCD standard grade powder. Typical exposure concentration: refer to footnote (1).
Chemical Process: Compounding of Polystyrene Resin to Produce XPS Masterbatch; Manufacture of XPS from HBCD powder, granules, or XPS masterbatch; and Manufacture of EPS resin beads				
Exposure Concentration	HBCD standard grade powder	RWC: 2.5 mg/m ³	The basis is the worker exposure monitoring data for the manufacture of EPS resin that are reported in Searl and Robertson (2005) – 2a-d of Table_Apx E-1 of this report.	The RWC exposure concentration was assessed by accounting for both addition and weighing as follows: <ol style="list-style-type: none"> 1. Addition of HBCD – the 90th percentile value, 1.3 mg/m³ (Searl and Robertson (2005) - 2b), was used. 2. Weighing of HBCD – the 90th percentile value, 10.5 mg/m³ (Searl and Robertson (2005)– 2d), was used. This task is 10-15 percent of the long-term working time due to task rotation and therefore, only a fraction of this concentration was assessed (~10 percent or 1.1 mg/m³).
		Typical: 1.25 mg/m ³	The rationale is that this data is based on a greater number of samples.	

Assessment Parameter				
				The RWC concentration used in this exposure assessment is the sum of 1.3 mg/m ³ and 1.1 mg/m ³ , which is approximately equal to 2.5 mg/m ³ . Typical exposure concentration: refer to footnote (1).
	HBCD granules	RWC: 0.22 mg/m ³	The basis is the monitoring data for the manufacture of XPS from HBCD granules that are reported in Abbott (2001) - 1b of Table_Apx E-1 of this report.	The approach is not explained beyond that the data referenced under Basis is more representative than other similar data (<i>i.e.</i> , Thomsen (2007) – 1a-bof Table_Apx E-1) and that more emphasis on personal sampling was given in selecting an assessed value. Typical exposure concentration: refer to footnote (1).
		Typical: 0.11 mg/m ³		
	master batch	RWC: 0.22 mg/m ³	The basis is the monitoring data for the manufacture XPS from master batch that are reported in Searl and Robertson (2005) - 3a-dof Table_Apx E-1 of this report.	The RWC exposure concentration was assessed to be equal to the 90th percentile of the concentration measurements referenced under Basis. Typical exposure concentration: refer to footnote (1).
		Typical: 0.11 mg/m ³		

Source: (ECHA 2008b) European Chemicals Agency. Risk Assessment for Hexabromocyclododecane: Final Report. May 2008.

RWC – Reasonable Worst Case

¹ Typical concentration was assessed to be equal to one half of the assessed RWC concentration. The rationale for this approach is that measured data indicates that the median value is approximately half the RWC.

Table_Apx E-4. Summary of HBCD Occupational Exposure Assessment Results and the Associated Assessment Basis and Approach that are Reported in NICNAS (2012)

Assessment Parameter				
Chemical Process: Compounding of Polystyrene Resin to Produce XPS Masterbatch, Manufacture of XPS from HBCD powder or granules, Manufacture of XPS from XPS Master Batch, and Manufacture of EPS Resin				
Exposure Concentration	HBCD standard grade powder	RWC: 1.1 mg/m ³ (addition) 10.5 mg/m ³ (weighing)	The basis is the worker exposure monitoring data for the manufacture of EPS resin that are reported in Searl and Robertson (2005) - 2b (for addition) and Searl and Robertson (2005) - 2d (for weighing) of Table_Apx E-1 of this report.	The RWC exposure concentration was assessed to be equal to the 90th percentile of the concentration measurements referenced under Basis.
		Typical: 0.27 mg/m ³ (addition) 6.19 mg/m ³ (weighing)	Overseas measurements were considered applicable due to similarities in tasks. Use of the full-shift measurements for addition is preferred.	The typical exposure concentration was assessed to be equal to the median of the concentration measurements referenced under Basis.
	HBCD granules and XPS master batch	RWC: 0.37 mg/m ³	The basis is the worker exposure monitoring data for manufacture of XPS from HBCD granules that are reported in Abbott (2001) - 1b of Table_Apx E-1 of this report.	The RWC exposure concentration was assessed to be equal to the 90th percentile value referenced under Basis.
		Typical: 0.08 mg/m ³		The typical exposure concentration was assessed to be equal to the highest LOD, which is 0.08 mg/m ³ the median concentration is lower than the LOD for a high proportion of samples.
Exposure Duration	HBCD standard grade powder	1 hour/day	The basis for this assumption is on the weighing and addition tasks at plants producing EPS. The tasks took 10 to 15 minutes per batch. Overall, weighing and transfer of HBCD took about an hour a week.	The exposure duration is assumed to be 0.5 hour/day for addition and 0.5 hour/day for weighing.
	HBCD granules		Based on the study conducted by the European Extruded Polystyrene Insulation Board Association on the	

Assessment Parameter				
			measured airborne concentration of HBCD in the production of XPS resin from HBCD granules. The main relevant tasks were emptying boxes and cleaning the feed deck, which took approximately 0.25 hour daily and 1 hour weekly.	
Exposure Frequency	HBCD standard grade powder	1 day/year	This is based on occupational exposure scenarios for masterbatch compounding from sites in Australia.	Not applicable
	HBCD standard grade powder and HBCD granules	180 days/year	This is based on occupational exposure scenarios for EPS resin compounding from sites in Australia.	Not applicable

Table_Apx E-5. Summary of Approaches from Other Risk Assessment Reports (RARs)

Row	Life Cycle Stage	Inhalation Exposures	Oral Exposures	Dermal Exposures	Environmental Releases
1	Repackaging of import containers	See Table_Apx E-3 and Table_Apx E-4	The EURAR and NICNAS RAR assumed 100% absorption of inhalable particulates.	Neither the EU nor the NICNAS RARs included monitoring data for dermal exposures. These RARs modelled dermal exposures using the EASE model.	EURAR assessed releases from manufacturing of HBCD and not Import / repackaging. NICNAS RAR assessed releases with the OECD ESD on Plastic Additives (OECD 2009).
2	Compounding of polystyrene to produce XPS masterbatch	See Table_Apx E-3 and Table_Apx E-4	The EURAR and NICNAS RAR assumed 100% absorption of inhalable particulates.	The methodology described in Row 1 was also used in this exposure scenario.	EURAR assessed releases with site-specific data. NICNAS RAR assessed only dust releases with the OECD ESD on Plastic Additives (OECD 2009). Environmental Canada RAR assessed only dust releases with the OECD ESD on Plastic Additives (OECD 2009).
3	Manufacture of XPS foam from XPS masterbatch	See Table_Apx E-3 and Table_Apx E-4	The EURAR and NICNAS RAR assumed 100% absorption of inhalable particulates.	The methodology described in Row 1 was also used in this exposure scenario.	EURAR assessed releases with site-specific data. NICNAS RAR assessed only dust releases with the OECD ESD on Plastic Additives (OECD 2009).
4	Manufacture of XPS foam using HBCD powder	See Table_Apx E-3 and Table_Apx E-4	The EURAR and NICNAS RAR assumed 100% absorption of inhalable particulates.	The methodology described in Row 1 was also used in this exposure scenario.	EURAR assessed releases with site-specific data. NICNAS RAR assessed only dust releases with the OECD ESD on Plastic Additives (OECD 2009).
5	Manufacture of EPS foam from imported EPS resin beads	See Table_Apx E-3 and Table_Apx E-4	The EU and NICNAS RARs assessed exposures from the production of EPS resin and indicated that exposures are expected to be low during the conversion of these EPS resin beads	The EU and NICNAS RARs assessed exposures from the production of EPS resin and indicated that exposures are expected to be low during the conversion of these EPS resin beads into EPS foam, thus were not assessed.	EURAR assessed only dust releases with the OECD ESD on Plastic Additives (OECD 2009). NICNAS RAR assessed only dust releases with the OECD ESD on Plastic Additives (OECD 2009).

Row	Life Cycle Stage	Inhalation Exposures	Oral Exposures	Dermal Exposures	Environmental Releases
			into EPS foam, thus were not assessed.		
6	Manufacture of SIPs and Automobile Replacement Parts from XPS or EPS	See Table_Apx E-3 and Table_Apx E-4	Because of the low inhalation exposure potential, the EU and NICNAS RARs did not assess oral exposures during this exposure scenario.	The EU and NICNAS RARs indicate that, because HBCD is incorporated into the foam matrix, dermal exposure is unlikely and is not assessed.	EURAR assessed releases with data on particulate emission rates during cutting and sawing of EPS and XPS foam. NICNAS RAR did not assess this release.
7	Installation of Automobile Replacement Parts	See Table_Apx E-3 and Table_Apx E-4	The methodology described in Row 6 was also used in this exposure scenario.	The methodology described in Row 6 was also used in this exposure scenario.	The RARs reviewed did not assess this exposure scenario.
8	Installation of XPS/EPS Foam Insulation in Residential, Public and Commercial Buildings, and Other Structures	See Table_Apx E-3 and Table_Apx E-4	The methodology described in Row 6 was also used in this exposure scenario.	The methodology described in Row 6 was also used in this exposure scenario.	EURAR assessed releases with data on particulate emission rates during cutting and sawing of EPS and XPS foam. NICNAS RAR did not assess this release.
9	Demolition and Disposal of XPS/EPS Foam Insulation in Residential, Public and Commercial Buildings, and Other Structures	The EU and NICNAS RARs did not assess occupational exposures during this exposure scenario.	The EU and NICNAS RARs did not assess occupational exposures during this exposure scenario.	The EU and NICNAS RARs did not assess occupational exposures during this exposure scenario.	EURAR assessed releases with data on particulate emission rates during breaking of EPS and XPS foam. The EURAR did not quantify disposal releases. NICNAS RAR assessed a steady-state scenario, where all HBCD imported is releases. NICNAS subtracted upstream losses and assumed the remaining amount was released in this exposure scenario.
10	Recycling of EPS Foam	The EU and NICNAS RARs did not assess	The EU and NICNAS RARs did not assess occupational exposures during this exposure scenario.	The EU and NICNAS RARs did not assess occupational exposures during this exposure scenario.	The EU and NICNAS RARs did not assess releases during this exposure scenario.

Row	Life Cycle Stage	Inhalation Exposures	Oral Exposures	Dermal Exposures	Environmental Releases
		occupational exposures during this exposure scenario.			
11	Formulation of Flux / Solder Pastes	This exposure scenario was not included in the identified RARs.	This exposure scenario was not included in the identified RARs.	This exposure scenario was not included in the identified RARs.	This exposure scenario was not included in the identified RARs.
12	Use of Flux / Solder Pastes	This exposure scenario was not included in the identified RARs.	This exposure scenario was not included in the identified RARs.	This exposure scenario was not included in the identified RARs.	This exposure scenario was not included in the identified RARs.

E.3 Equations for Calculating Acute and Chronic (Non-Cancer) Inhalation Exposures

This report assesses HBCD exposures to workers in occupational settings, presented as 8-hr time weighted average (TWA). The 8-hr TWA exposures are then used to calculate acute exposure, average daily dose (ADD) for chronic, non-cancer risks.

Acute workplace exposures are assumed to be equal to the contaminant concentration in air (8-hr TWA), per Equation E-4.

Equation E-1:

$$AED = \frac{C \times ED \times b}{BW}$$

Where:

- AED = Acute exposure dose (mg/kg-day)
- C = Contaminant concentration in air (TWA) (mg/m³)
- ED = exposure duration (8 hr/day)
- b = breathing rate (1.25 m³/hr)
- BW = body weight (80 kg)

ADD is used to estimate workplace chronic exposures for non-cancer risks. These exposures are estimated as follows:

Equation E-2:

$$ADD = \frac{C \times ED \times b \times EF \times WY}{BW \times AT}$$

Where:

- ADD = average daily dose used for chronic non-cancer risk calculations (mg/kg-day)
- C = contaminant concentration in air (8-hr TWA) (mg/m³)
- ED = exposure duration (8 hr/day)
- b = breathing rate (1.25 m³/hr)
- EF = exposure frequency (days/yr)
- WY = exposed working years per lifetime (50th percentile = 31; 95th percentile = 40)
- BW = body weight (80 kg)
- AT = averaging time, non-cancer risks (WY × 365 days/yr)

Table_Apx E-6 Parameter Values for Calculating Inhalation Exposure Estimates

Parameter Name	Symbol	Value	Unit
Exposure Duration	ED	8	hr/day
Breathing Rate	b	1.25 ^a	m ³ /hr
Exposure Frequency	EF	discussed in Section 2	days/year
Working Years	WY	31 (50 th percentile)	years

Parameter Name	Symbol	Value	Unit
		40 (95 th percentile)	
Body Weight	BW	80 (average adult worker) 72.4 (female of reproductive age)	kg
Averaging Time, non-cancer	AT	11,315 (CT) ^b 14,600 (HE) ^c	days

^a(U.S. EPA 2011b) provides breathing rates for pregnant and lactating females, breathing rate used is for light activity for workers which is higher than these specific rates provided for pregnant and lactating females.

^b Calculated using the 50th percentile value for working years (WY)

^c Calculated using the 95th percentile value for working years (WY)

Exposure Duration (ED)

EPA uses an exposure duration of 8 hours per day for averaging full-shift exposures.

Breathing Rate (b)

EPA uses a breathing rate of 1.25 m³ per hour for workers (representing adults undergoing light activity).

Exposure Frequency (EF)

EPA estimated a range of exposure frequency based on the number of operation days that EPA determined for each exposure scenario, except for The Installation of XPS/EPS Foam Insulation and the Demolition and Disposal of XPS/EPS Foam Insulation. For these exposure scenarios, EPA estimated a range of exposure frequency of 1 day/year, based on release frequency, up to 250 days/year, based on worker schedules as described below. The assessed exposure frequency did not exceed 250 days/year, based on a worker schedule of 5 days/week over 50 weeks/year. With this range of exposure frequency, EPA used the midpoint of this range to calculate central tendency average daily dose and the high-end of this range to calculate high-end average daily dose. EPA's choice of these exposure frequencies are further described in Section 2.3.

Exposure frequency (EF) is expressed as the number of days per year a worker is exposed to the chemical being assessed. In some cases, it may be reasonable to assume a worker is exposed to the chemical on each working day. In other cases, it may be more appropriate to estimate a worker's exposure to the chemical occurs during a subset of the worker's annual working days. The relationship between exposure frequency and annual working days can be described mathematically as follows:

$$EF = f \times AWD$$

Where:

EF = exposure frequency, the number of days per year a worker is exposed to the chemical (day/yr)

f = fractional number of annual working days during which a worker is exposed to the chemical (unitless)

AWD = annual working days, the number of days per year a worker works (day/yr)

BLS ([2014](#)) provides data on the total number of hours worked and total number of employees by each industry NAICS code. These data are available from the 3- to 6-digit NAICS level (where 3-digit NAICS are less granular and 6-digit NAICS are the most granular). Dividing the total, annual hours worked by the number of employees yields the average number of hours worked per employee per year for each NAICS.

EPA has identified approximately 140 NAICS codes applicable to the multiple exposure scenarios for the 10 chemicals undergoing Risk Evaluation. For each NAICS code of interest, EPA looked up the average hours worked per employee per year at the most granular NAICS level available (*i.e.*, 4-digit, 5-digit, or 6-digit). EPA converted the working hours per employee to working days per year per employee assuming employees work an average of eight hours per day. The average number of days per year worked, or AWD, ranges from 169 to 282 days per year, with a 50th percentile value of 250 days per year. EPA repeated this analysis for all NAICS codes at the 4-digit level. The average AWD for all 4-digit NAICS codes ranges from 111 to 282 days per year, with a 50th percentile value of 228 days per year. 250 days per year is approximately the 75th percentile.

In the absence of industry- and HBCD-specific data, EPA assumes the parameter f is equal to one for all exposure scenarios.

Working Years (WY)

EPA has developed a triangular distribution for working years. EPA has defined the parameters of the triangular distribution as follows:

- **Minimum value:** BLS CPS tenure data with current employer as a low-end estimate of the number of lifetime working years: 10.4 years;
- **Mode value:** The 50th percentile tenure data with all employers from Survey of Income and Program Participation (SIPP) as a mode value for the number of lifetime working years: 36 years; and
- **Maximum value:** The maximum average tenure data with all employers from SIPP as a high-end estimate on the number of lifetime working years: 44 years.

This triangular distribution has a 50th percentile value of 31 years and a 95th percentile value of 40 years. EPA uses these values for central tendency and high-end ADD calculations, respectively.

The BLS ([2014](#)) provides information on employee tenure with *current employer* obtained from the Current Population Survey (CPS). CPS is a monthly sample survey of about 60,000 households that provides information on the labor force status of the civilian non-institutional population age 16 and over; CPS data are released every two years. The data are available by demographics and by generic industry sectors but are not available by NAICS codes.

The U.S. Census' ([Census Bureau 2016](#)) Survey of Income and Program Participation (SIPP) provides information on *lifetime tenure with all employers*. SIPP is a household survey that collects data on income, labor force participation, social program participation and eligibility, and general demographic characteristics through a continuous series of national panel surveys of between 14,000 and 52,000 households ([Census Bureau 2016](#)). EPA analyzed the 2008 SIPP Panel Wave 1, a panel that began in 2008 and covers the interview months of September 2008 through December 2008 ([Census Bureau](#)

[2016](#)). For this panel, lifetime tenure data are available by Census Industry Codes, which can be cross-walked with NAICS codes.

SIPP data include fields for the industry in which each surveyed, employed individual works (TJBIND1), worker age (TAGE), and years of work experience *with all employers* over the surveyed individual's lifetime.²² Census household surveys use different industry codes than the NAICS codes used in its firm surveys, so these were converted to NAICS using a published crosswalk ([Census Bureau 2012](#)). EPA calculated the average tenure for the following age groups: 1) workers age 50 and older; 2) workers age 60 and older; and 3) workers of all ages employed at time of survey. EPA used tenure data for age group "50 and older" to determine the high-end lifetime working years, because the sample size in this age group is often substantially higher than the sample size for age group "60 and older." For some industries, the number of workers surveyed, or the *sample size*, was too small to provide a reliable representation of the worker tenure in that industry. Therefore, EPA excluded data where the sample size is less than five from our analysis.

Table_Apx E-7 summarizes the average tenure for workers age 50 and older from SIPP data. Although the tenure may differ for any given industry sector, there is no significant variability between the 50th and 95th percentile values of average tenure across manufacturing and non-manufacturing sectors.

Table_Apx E-7. Overview of Average Worker Tenure from U.S. Census SIPP (Age Group 50+)

Industry Sectors	Working Years			
	Average	50 th Percentile	95 th Percentile	Maximum
All industry sectors relevant to the 10 chemicals undergoing Risk Evaluation	35.9	36	39	44
Manufacturing sectors (NAICS 31-33)	35.7	36	39	40
Non-manufacturing sectors (NAICS 42-81)	36.1	36	39	44

Source: ([Census Bureau 2016](#))

Note: Industries where sample size is less than five are excluded from this analysis.

BLS CPS data provides the median years of tenure that wage and salary workers had been with their current employer. Table_Apx E-8 presents CPS data for all demographics (men and women) by age group from 2008 to 2012. To estimate the low-end value on number of working years, EPA uses the most recent ([U.S. BLS 2014](#)) CPS data for workers age 55 to 64 years, which indicates a median tenure of 10.4 years with their current employer. The use of this low-end value represents a scenario where workers are only exposed to the chemical of interest for a portion of their lifetime working years, as they may change jobs or move from one industry to another throughout their career.

Table_Apx E-8. Median Years of Tenure with Current Employer by Age Group

Age	January 2008	January 2010	January 2012	January 2014
16 years and over	4.1	4.4	4.6	4.6
16 to 17 years	0.7	0.7	0.7	0.7

²² To calculate the number of years of work experience we took the difference between the year first worked (TMAKMNYR) and the current data year (*i.e.*, 2008). We then subtracted any intervening months when not working (ETIMEOFF).

Age	January 2008	January 2010	January 2012	January 2014
18 to 19 years	0.8	1.0	0.8	0.8
20 to 24 years	1.3	1.5	1.3	1.3
25 years and over	5.1	5.2	5.4	5.5
25 to 34 years	2.7	3.1	3.2	3.0
35 to 44 years	4.9	5.1	5.3	5.2
45 to 54 years	7.6	7.8	7.8	7.9
55 to 64 years	9.9	10.0	10.3	10.4
65 years and over	10.2	9.9	10.3	10.3

Source: ([U.S. BLS 2014](#))

Body Weight (BW)

EPA assumes a body weight of 80 kg for all worker demographics.

E.4 Sample Calculations for Calculating Acute and Chronic (Non-Cancer) Inhalation Exposure

Sample calculations for high-end and central tendency chronic exposure doses for one setting, Repackaging of Import Containers, are demonstrated below. The explanation of the equations and parameters used is provided in Appendix E.3.

Example High-End ADD

Calculate ADD_{HE}:

$$ADD_{HE} = \frac{C_{HE} \times b \times ED \times EF \times WY}{BW \times AT}$$

$$ADD_{HE} = \frac{1.89 \frac{mg}{m^3} \times 1.25 \frac{m^3}{hr} \times 8 \frac{hr}{day} \times 60 \frac{days}{year} \times 40 \text{ years}}{80 \text{ kg} \times \left(40 \text{ years} \times 365 \frac{days}{year}\right)} = 3.88 \times 10^{-2} \frac{mg}{kg - day}$$

Example Central Tendency ADD

Calculate ADD_{CT}:

$$ADD_{CT} = \frac{C_{CT} \times b \times ED \times EF \times WY}{BW \times AT_{ADD}}$$

$$ADD_{CT} = \frac{0.89 \frac{mg}{m^3} \times 1.25 \frac{m^3}{hr} \times 8 \frac{hr}{day} \times 60 \frac{days}{year} \times 31 \text{ years}}{80 \text{ kg} \times \left(31 \text{ years} \times 365 \frac{days}{year}\right)} = 1.83 \times 10^{-2} \frac{mg}{kg - day}$$

E.5 Approaches for Estimating Number of Workers

This appendix summarizes the methods and provides an example of the method that EPA used to estimate the number of workers who are potentially exposed to HBCD in each of its exposure scenarios. The method consists of the following steps:

- Identify the North American Industry Classification System (NAICS) codes for the industry sectors associated with each exposure scenario.
- Estimate total employment by industry/occupation combination using the Bureau of Labor Statistics' occupational employment statistics data ([U.S. BLS 2016](#)).
- Refine the occupational employment statistics estimates where they are not sufficiently granular by using the U.S. Census' (2015) Statistics of U.S. Businesses (SUSB) data on total employment by 6-digit NAICS ([Census Bureau 2015](#)).
- Estimate the number of potentially exposed employees per site.
- Estimate the number of potentially exposed employees within the exposure scenario using the estimated number of sites.

Step 1: Identifying Affected NAICS Codes

As a first step, EPA identified NAICS industry codes associated with each exposure scenario. EPA generally identified NAICS industry codes for an exposure scenario by:

- Querying the [U.S. Census Bureau's NAICS Search tool](#) using keywords associated with each exposure scenario to identify NAICS codes with descriptions that match the exposure scenario.
- Referencing EPA/OPPT Generic Scenarios (GS's) and Organisation for Economic Co-operation and Development (OECD) Emission Scenario Documents (ESDs) for an exposure scenario to identify NAICS codes cited by the GS or ESD.
- Reviewing Chemical Data Reporting (CDR) data for the chemical, identifying the industrial sector codes reported for downstream industrial uses, and matching those industrial sector codes to NAICS codes using Table_Apx D-2 provided in the [CDR reporting instructions](#).

Each exposure scenario section in the main body of this report identifies the NAICS codes EPA identified for the respective exposure scenario.

Step 2: Estimating Total Employment by Industry and Occupation

BLS's ([2016](#)) occupational employment statistics data provide employment data for workers in specific industries and occupations. The industries are classified by NAICS codes (identified previously), and occupations are classified by Standard Occupational Classification (SOC) codes.

Among the relevant NAICS codes (identified previously), EPA reviewed the occupation description and identified those occupations (SOC codes) where workers are potentially exposed. Table_Apx E-9. shows the SOC codes EPA classified as occupations potentially exposed. These occupations are classified into workers (W) and occupational non-users (O). All other SOC codes are assumed to represent occupations where exposure is unlikely. An example is provided below for an exposure scenario of dry cleaning.

Table_Apx E-9. SOCs with Worker and ONU Designations for All Exposure scenarios

After identifying relevant NAICS and SOC codes, EPA/OPPT used BLS data to determine total employment by industry and by occupation based on the NAICS and SOC combinations. For example,

there are 1,790 employees associated with 4-digit NAICS 3259 (*Other Chemical Product and Preparation Manufacturing*) and SOC 49-9070 (*Maintenance and Repair Workers, General*).

Using a combination of NAICS and SOC codes to estimate total employment provides more accurate estimates for the number of workers than using NAICS codes alone. Using only NAICS codes to estimate number of workers typically result in an overestimate, because not all workers employed in that industry sector will be exposed. However, in some cases, BLS only provide employment data at the 4-digit or 5-digit NAICS level; therefore, further refinement of this approach may be needed (see next step).

Step 3: Refining Employment Estimates to Account for lack of NAICS Granularity

The third step in EPA's methodology was to further refine the employment estimates by using total employment data in the U.S. Census Bureau's SUSB ([Census Bureau 2015](#)). In some cases, BLS occupational employment statistics' occupation-specific data are only available at the 4-digit or 5-digit NAICS level, whereas the SUSB data are available at the 6-digit level (but are not occupation-specific). Identifying specific 6-digit NAICS will ensure that only industries with potential exposure are included. As an example, occupational employment statistics data are available for the 4-digit NAICS 3259 *Other Chemical Product and Preparation Manufacturing*, which includes the following 6-digit NAICS:

1. NAICS 325910 Printing Ink Manufacturing;
2. NAICS 325920 Explosives Manufacturing;
3. NAICS 325991 Custom Compounding of Purchased Resins;
4. NAICS 325992 Photographic Film, Paper, Plate, and Chemical Manufacturing; and
5. NAICS 325998 All Other Miscellaneous Chemical Product and Preparation Manufacturing.

In this example, only NAICS 325991 is of interest. The Census data allow EPA to calculate employment in the specific 6-digit NAICS of interest as a percentage of employment in the BLS 4-digit NAICS.

The 6-digit NAICS 325991 comprises 23.5 percent of total employment under the 4-digit NAICS 3259. This percentage can be multiplied by the occupation-specific employment estimates given in the BLS OES data to further refine our estimates of the number of employees with potential exposure.

Table_Apx E-10 illustrates this granularity adjustment for NAICS 325991.

Table_Apx E-10. Estimated Number of Potentially Exposed Workers and ONUs under NAICS 325991

NAICS	SOC CODE	SOC Description	Occupation Designation	Employment by SOC at 4-digit NAICS level	% of Total Employment	Estimated Employment by SOC at 6-digit NAICS level
325900	17-2000	Engineers	O	3,010	23.5%	709
325900	17-3000	Drafters, Engineering Technicians, and Mapping Technicians	O	860	23.5%	202
325900	19-2031	Chemists	O	1,400	23.5%	330
325900	19-4000	Life, Physical, and Social Science Technicians	O	1,810	23.5%	426
325900	47-2000	Construction Trades Workers	W	200	23.5%	47

NAICS	SOC CODE	SOC Description	Occupation Designation	Employment by SOC at 4-digit NAICS level	% of Total Employment	Estimated Employment by SOC at 6-digit NAICS level
325900	49-1000	Supervisors of Installation, Maintenance, and Repair Workers	O	340	23.5%	80
325900	49-2000	Electrical and Electronic Equipment Mechanics, Installers, and Repairers	W	260	23.5%	61
325900	49-9010	Control and Valve Installers and Repairers	W	60	23.5%	14
325900	49-9040	Industrial Machinery Installation, Repair, and Maintenance Workers	W	1,720	23.5%	405
325900	49-9060	Precision Instrument and Equipment Repairers	W	30	23.5%	7
325900	49-9070	Maintenance and Repair Workers, General	W	1,790	23.5%	421
325900	49-9090	Miscellaneous Installation, Maintenance, and Repair Workers	W	80	23.5%	19
325900	51-1000	Supervisors of Production Workers	O	3,480	23.5%	819
325900	51-2000	Assemblers and Fabricators	W	5,270	23.5%	1,241
325900	51-4020	Forming Machine Setters, Operators, and Tenders, Metal and Plastic	W	1,170	23.5%	275
325900	51-6090	Miscellaneous Textile, Apparel, and Furnishings Workers	O	1,320	23.5%	311
325900	51-8020	Stationary Engineers and Boiler Operators	W	40	23.5%	9
325900	51-8090	Miscellaneous Plant and System Operators	W	1,530	23.5%	360
325900	51-9000	Other Production Occupations	W	24,880	23.5%	5,858
Total Potentially Exposed Employees				49,250		11,597
Total Workers						8,719
Total Occupational Non-Users						2,877

Note: numbers may not sum exactly due to rounding.

W = worker

O = occupational non-user

Source: ([Census Bureau 2015](#)); ([U.S. BLS 2016](#))

Step 4: Estimating the Percentage of Workers Using HBCD Instead of Other Chemicals

In the final step, EPA accounted for the market share by applying a factor to the number of workers determined in Step 3. This accounts for the fact that the substance may be only one of multiple chemicals used for the applications of interest. EPA did not identify market penetration data for any exposure scenarios. In the absence of market penetration data for a given exposure scenario, EPA/OPPT assumed HBCD may be used at up to all sites and by up to all workers calculated in this method as a bounding estimate. This assumes a market penetration of 100%. Market penetration is discussed for each exposure scenario in the main body of this report.

Step 5: Estimating the Number of Workers per Site

EPA/OPPT calculated the number of workers and occupational non-users in each industry/occupation combination using the formula below (granularity adjustment is only applicable where SOC data are not available at the 6-digit NAICS level):

$$\text{Number of Workers or ONUs in NAICS/SOC (Step 2)} \times \text{Granularity Adjustment Percentage (Step 3)} = \text{Number of Workers or ONUs in the Industry/Occupation Combination}$$

EPA/OPPT then estimated the total number of establishments by obtaining the number of establishments reported in the U.S. Census Bureau's SUSB data at the 6-digit NAICS level ([Census Bureau 2015](#)).

EPA then summed the number of workers and occupational non-users over all occupations within a NAICS code and divided these sums by the number of establishments in the NAICS code to calculate the average number of workers and occupational non-users per site.

Step 6: Estimating the Number of Workers and Sites for an Exposure Scenario

EPA estimated the number of workers and occupational non-users potentially exposed and the number of sites that use HBCD in a given exposure scenario through the following steps:

- Obtaining the total number of establishments by:
 - Obtaining the number of establishments from SUSB at the 6-digit NAICS level (Step 5) for each NAICS code in the exposure scenario and summing these values ([Census Bureau 2015](#)) or
 - Obtaining the number of establishments from the Toxics Release Inventory (TRI), Discharge Monitoring Report (DMR) data, National Emissions Inventory (NEI), or literature for the exposure scenario.
- Estimating the number of establishments that use HBCD by taking the total number of establishments from Step 6.A and multiplying it by the market penetration factor from Step 4.
- Estimating the number of workers and occupational non-users potentially exposed to HBCD by taking the number of establishments calculated in Step 6.B and multiplying it by the average number of workers and occupational non-users per site from Step 5.

E.6 Evaluation of Occupational Exposure Data Sources

EPA has reviewed acceptable sources for HBCD inhalation exposure data according to the data quality evaluation criteria found in [The Application of Systematic Review in TSCA Risk Evaluations](#) (U.S. EPA 2018b). Table_Apx E-11 summarizes the results of this evaluation. The data quality evaluation of inhalation monitoring data sources indicated the quality of the sources ranges from unacceptable to high; however, unacceptable data were excluded from the assessment of occupational inhalation exposure to HBCD.

Table_Apx E-11. Summary of Inhalation Monitoring Data and Systematic Review Results

Literature Study ^a	Exposure scenario	Data from source ^b						Source ^c	Data Identifier from Data Extraction and Evaluation	Overall Confidence Rating from Data Extraction and Evaluation	Rationale for Inclusion / Exclusion
		Form of HBCD Handled	Type of Sample	Worker Activity or Sampling Location	Exposure Concentration (mg/m ³)	Number of Samples	Sample Time / Type of Measurement				
Searl and Robertson (2005) - 1a	Manufacturing of HBCD	Standard grade HBCD	Personal Breathing Zone	Packaging, compaction, process operations, and working in the warehouse	Mean: 1.23 Median: 0.89 90th percentile: 1.89 Max: 3 mg/m ³	10	8-hr TWA	(ECHA 2008b) (ECHA 2009b)	3970747; 3809166	High	Included - although manufacturing of HBCD is not an exposure scenario, these data are applicable to the importation of HBCD
Searl and Robertson (2005) - 1b	Manufacturing of HBCD	Fine grade HBCD	Personal Breathing Zone	Packaging, compaction, process operations, and working in the warehouse	Mean: 23 90th percentile: 35	4	8-hr TWA	(ECHA 2008b)	3970747	High	Excluded - manufacturing is out of scope and, while this data may be applicable to other exposure scenarios, fine grade HBCD is not preferred
Searl and Robertson (2005) - 1c	Manufacturing of HBCD	HBCD of unknown grade	NR	Packaging and compaction of powders	Respirable, Mean: 0.18 Inhalable, Mean: 1.23	NR	NR	(ECHA 2009c)	3970759	High	Excluded - manufacturing is out of scope and, while this data may be applicable to other exposure scenarios, the grade of HBCD and sample time are unknown
Waindzioch (2000) - 1a	Manufacturing of HBCD	HBCD of unknown grade	Area	Reactor	0.00028 - 0.0285	3	Short-term	(ECHA 2008b)	3970747	Unacceptable	Excluded - manufacturing of HBCD is not an exposure scenario for this Risk Evaluation and this data is not applicable to other exposure scenarios
Waindzioch (2000) - 1b	Manufacturing of HBCD	HBCD of unknown grade	Area	Filling Station	0.0094 - 0.097	2	Short-term	(ECHA 2008b)	3970747	High	Excluded - manufacturing is out of scope and, while this data

Literature Study ^a	Exposure scenario	Data from source ^b						Source ^c	Data Identifier from Data Extraction and Evaluation	Overall Confidence Rating from Data Extraction and Evaluation	Rationale for Inclusion / Exclusion
		Form of HBCD Handled	Type of Sample	Worker Activity or Sampling Location	Exposure Concentration (mg/m ³)	Number of Samples	Sample Time / Type of Measurement				
											may be applicable to other exposure scenarios, area samples are not preferred
Bieseimer (1996)	Manufacturing of HBCD	HBCD of unknown grade	NR	Bagging HBCD product	4.0 - 4.5	NR	NR	(ECHA 2008b)	3970747	High	Excluded - manufacturing is out of scope and, while this data may be applicable to other exposure scenarios, sample type and time are unknown
Velsicol (1978)	Manufacturing of HBCD	HBCD of unknown grade	Personal Breathing Zone	Transfer of the HBCD in the hammer-mill to 28 drums	1.9	1	300 minutes	(Velsicol Chem Corp 1978)	1928232	High	Excluded - manufacturing is out of scope and, while this data may be applicable to other exposure scenarios, the grade of HBCD and sample time are unknown
Yi et al. (2016)	Manufacturing of HBCD	HBCD of unknown grade	Personal Breathing Zone	NR	0.0102 - 0.0283	14	NR	(Yi et al. 2016)	3350493	High	Excluded - manufacturing is out of scope and, while this data may be applicable to other exposure scenarios, the grade of HBCD and sample time are unknown
Searl and Robertson (2005) - 2a	Manufacturing of EPS Resin beads	Standard grade HBCD	Personal	Manual addition of HBCD powder to reactor each time a batch of EPS resin was produced	Range: 2.89-21.5 Mean: 7.2 Median: 5.52 90th percentile: 10.5	12	Short-term (13 to 56 mins)	(ECHA 2008b) (NICNAS 2012b)	3978355	High	Included - These data are the basis of the estimates developed by the EURAR for HBCD processing in the plastics

Literature Study ^a	Exposure scenario	Data from source ^b						Source ^c	Data Identifier from Data Extraction and Evaluation	Overall Confidence Rating from Data Extraction and Evaluation	Rationale for Inclusion / Exclusion
		Form of HBCD Handled	Type of Sample	Worker Activity or Sampling Location	Exposure Concentration (mg/m ³)	Number of Samples	Sample Time / Type of Measurement				
											industry, which were used by EPA in this Risk Evaluation
Searl and Robertson (2005) - 2b	Manufacturing of EPS Resin beads	Standard grade HBCD	Personal	Manual addition of HBCD powder to reactor each time a batch of EPS resin was produced	Range: 0.12-3.36 Mean: 1 Median: 0.42 90th percentile: 1.3	12	8-hr TWA – Note this is the 8-hr TWA of the data in the above row	(ECHA 2008b) (NICNAS 2012b)	3978355	High	Included - These data are the basis of the estimates developed by the EURAR for HBCD processing in the plastics industry, which were used by EPA in this Risk Evaluation
Searl and Robertson (2005) - 2c	Manufacturing of EPS Resin beads	Standard grade HBCD	Personal	Manual addition of HBCD powder to reactor each time a batch of EPS resin was produced	Range: 0.07-14.7 Mean: 1.2 Median: 0.27 90th percentile: 1.10	18	275 to 504 mins (NICNAS 2012b)	(ECHA 2008b) (NICNAS 2012b)	3978355	High	Included - These data are the basis of the estimates developed by the EURAR for HBCD processing in the plastics industry, which were used by EPA in this Risk Evaluation
Searl and Robertson (2005) - 2d	Manufacturing of EPS Resin beads	Standard grade HBCD	Personal	Weighing powder prior to addition to reactor. HBCD bags were weighed and opened concurrently, or weighed in advance, in which case HBCD was transferred from 25-kg sacks using	Range: 4.35-12.1 Mean: 7.2 Median: 6.19 90th percentile: 10.5	4	124 to 350 mins (NICNAS 2012b)	(ECHA 2008b) (NICNAS 2012b)	3978355	High	Included - These data are the basis of the estimates developed by the EURAR for HBCD processing in the plastics industry, which were used by EPA in this Risk Evaluation

Literature Study ^a	Exposure scenario	Data from source ^b						Source ^c	Data Identifier from Data Extraction and Evaluation	Overall Confidence Rating from Data Extraction and Evaluation	Rationale for Inclusion / Exclusion
		Form of HBCD Handled	Type of Sample	Worker Activity or Sampling Location	Exposure Concentration (mg/m ³)	Number of Samples	Sample Time / Type of Measurement				
				plastic scoop (full-shift measurement).							
Searl and Robertson (2005) - 3a	Compounding of Polystyrene resin to produce XPS Masterbatch containing HBCD	HBCD of unknown grade	Area	Weighing and mixing	Max 7.5 (for 2 hours) Mean: 1.89 Median: 0.83 90th percentile: 5.4	10	Short-term	(ECHA 2008b) (ECHA 2009b)	3970747; 3809166	High	Excluded - EPA used the estimates for HBCD processing in the plastics industry calculated in the EURAR from the available data (See Appendix E.2)
Searl and Robertson (2005) - 3b	Compounding of Polystyrene resin to produce XPS Masterbatch containing HBCD	HBCD of unknown grade	Area	Weighing and mixing	Mean: 0.88 90th percentile: 1.36	10	8-hr TWA	(ECHA 2008b)	3970747	High	Excluded - EPA used the estimates for HBCD processing in the plastics industry calculated in the EURAR from the available data (See Appendix E.2)
Searl and Robertson (2005) - 3c	Compounding of Polystyrene resin to produce XPS Masterbatch containing HBCD	HBCD of unknown grade	NR	Extruder	Mean: 0.12 Median: 0.10 90th percentile: 0.16	4	5 hours	(ECHA 2008b) (ECHA 2009b)	3970747; 3809166	High	Excluded - EPA used the estimates for HBCD processing in the plastics industry calculated in the EURAR from the available data (See Appendix E.2)
Searl and Robertson (2005) - 3d	Compounding of Polystyrene resin to produce XPS Masterbatch containing HBCD	HBCD of unknown grade	NR	Automated handling of HBCD	Negligible	3	NR	(ECHA 2008b)	3970747	High	Excluded - EPA used the estimates for HBCD processing in the plastics industry calculated in the EURAR from the available data (See Appendix E.2)

Literature Study ^a	Exposure scenario	Data from source ^b						Source ^c	Data Identifier from Data Extraction and Evaluation	Overall Confidence Rating from Data Extraction and Evaluation	Rationale for Inclusion / Exclusion
		Form of HBCD Handled	Type of Sample	Worker Activity or Sampling Location	Exposure Concentration (mg/m ³)	Number of Samples	Sample Time / Type of Measurement				
Abbott (2001) - 1a	Manufacture of XPS from HBCD powder or granules	Standard grade HBCD	Area	At the feed deck near typical operator positions	Range 0.24 – 1.6 Mean: 0.66 90th percentile: 1.45 (excluding 10 ND samples)	16 (10 ND)	8-hr TWA	(ECHA 2008b)	3970747	High	Excluded - EPA used the estimates for HBCD processing in the plastics industry calculated in the EURAR from the available data (See Appendix E.2)
Abbott (2001) - 1b	Manufacture of XPS from HBCD powder or granules	HBCD granules	Mostly area and some personal breathing zone	Feed deck near typical operator positions	Range 0.005-0.9 Mean: 0.24 90th percentile: 0.47 (excluding 16 ND samples)	43 (16 ND)	60 – 1435 minutes	(ECHA 2008b)	3970747	High	Excluded - EPA used the estimates for HBCD processing in the plastics industry calculated in the EURAR from the available data (See Appendix E.2)
Thomsen (2007) - 1a	Manufacture of XPS from HBCD powder or granules	HBCD powder and granules	Personal breathing zone	Activities in the mixer area, including operating a closed automated process excluding potential contact with neat HBCD	Range: 0.0002-0.0009 Mean: 0.0005 Median: 0.0005	6	8-hr TWA	(ECHA 2008b) (NICNAS 2012b)	3970747; 3978355	High	Excluded - EPA used the estimates for HBCD processing in the plastics industry calculated in the EURAR from the available data (See Appendix E.2)
Thomsen (2007) - 1b	Manufacture of XPS from HBCD powder or granules	HBCD powder and granules	Personal breathing zone	Weighing and addition of HBCD to the reactor and subsequent washing, centrifugation, sifting, and transfer of product to a silo container	Range: 0.001-0.15 Mean: 0.015 Median: 0.0027	24	8-hr TWA	(ECHA 2008b) (NICNAS 2012b)	3970747; 3978355	High	Excluded - EPA used the estimates for HBCD processing in the plastics industry calculated in the EURAR from the available data (See Appendix E.2)

Literature Study ^a	Exposure scenario	Data from source ^b						Source ^c	Data Identifier from Data Extraction and Evaluation	Overall Confidence Rating from Data Extraction and Evaluation	Rationale for Inclusion / Exclusion
		Form of HBCD Handled	Type of Sample	Worker Activity or Sampling Location	Exposure Concentration (mg/m ³)	Number of Samples	Sample Time / Type of Measurement				
Searl and Robertson (2005) - 4	Manufacture of XPS from HBCD powder or granules	HBCD granules	Area	Logistics, extruding, and laboratory	Mean: 0.00003 90th percentile: 0.00004	12	8-hr TWA	(ECHA 2008b)	3970747	High	Excluded - EPA used the estimates for HBCD processing in the plastics industry calculated in the EURAR from the available data (See Appendix E.2)
Ransbotyn (1999)	Manufacturing of EPS Resin beads	Respirable Dust Inhalable Dust	Personal	Addition of HBCDD to reactor or the supervising of the addition.	Respirable dust: <0.5 Total Inhalable dust: 2.0 Not specific to HBCD	5	Max 8-hr TWA	(ECHA 2008b)	3970747	High	Excluded - EPA used the estimates for HBCD processing in the plastics industry calculated in the EURAR from the available data (See Appendix E.2)
NICNAS (2012) - 1a	HBCD importation / repackaging sites and all industrial polymer processing sites	Standard grade HBCD	Modelled with EASE	Addition of HBCD into process operation	Typical: 2 to 5 Worst-case: 5 to 50	Not applicable - this is a modelled exposure	8-hr TWA	(NICNAS 2012b)	3978355	High	Excluded - EPA used the estimates for HBCD processing in the plastics industry calculated in the EURAR from the available data (See Appendix E.2)
NICNAS (2012) - 1b	HBCD importation / repackaging sites and all industrial polymer processing sites	HBCD granules	Modelled with EASE	Repackaging with the use of LEV (typical) and without LEV (worst-case)	Typical: 0.2 to 0.5 Worst-case: 0.5 to 5	Not applicable - this is a modelled exposure	8-hr TWA	(NICNAS 2012b)	3978355	High	Excluded - EPA used the estimates for HBCD processing in the plastics industry calculated in the EURAR from the available data (See Appendix E.2)
Searl and Robertson (2005) - 5a	Secondary processing of XPS foam (cutting,	XPS foam	NR	Secondary processing of XPS foam - including cutting,	Mean: 0.08 90th percentile: 0.22	9	8-hr TWA	Original source: Searl and Robertson (2005)	3809166	High	Included - these data were used to estimate worker inhalation exposure in the

Literature Study ^a	Exposure scenario	Data from source ^b						Source ^c	Data Identifier from Data Extraction and Evaluation	Overall Confidence Rating from Data Extraction and Evaluation	Rationale for Inclusion / Exclusion
		Form of HBCD Handled	Type of Sample	Worker Activity or Sampling Location	Exposure Concentration (mg/m ³)	Number of Samples	Sample Time / Type of Measurement				
	sawing, machining)			sawing, and machining to manufacture shaped products				Reported in: (ECHA 2008b) ; (ECHA 2009b)			following exposure scenarios: Manufacturing of XPS Foam using XPS Masterbatch; Manufacturing of EPS Foam from Imported EPS Resin Beads; Manufacturing of SIPs and Automobile Replacement Parts from XPS/EPS Foam; Installation of XPS/EPS Foam Insulation in Residential, Public and Commercial Buildings, and Other Structures; Demolition and Disposal of XPS/EPS Foam Insulation Products in Residential, Public and Commercial Buildings, and Other Structures; Recycling of EPS Foam and Reuse of XPS Foam
Searl and Robertson (2005) - 5b	Reclamation of XPS foam - including shredding and reprocessing of process waste	XPS foam	NR	Reclamation of XPS foam - including shredding and reprocessing of process waste	Mean: 0.02 90th percentile: 0.02	5	8-hr TWA	Original source: Searl and Robertson (2005) Reported in:	3809166	High	Excluded - EPA used the data in Searl and Robertson (2005) - 5a because it presents a larger

Literature Study ^a	Exposure scenario	Data from source ^b						Source ^c	Data Identifier from Data Extraction and Evaluation	Overall Confidence Rating from Data Extraction and Evaluation	Rationale for Inclusion / Exclusion
		Form of HBCD Handled	Type of Sample	Worker Activity or Sampling Location	Exposure Concentration (mg/m ³)	Number of Samples	Sample Time / Type of Measurement				
								(ECHA 2008b); (ECHA 2009b)			range of potential exposure
Searl and Robertson (2005) - 5c	Manufacture of XPS from XPS masterbatch	XPS foam	NR	Other process control operators	Mean: 0.03 90th percentile: 0.03	4	8-hr TWA	Original source: Searl and Robertson (2005) Reported in: (ECHA 2008b); (ECHA 2009b)	3809166	High	Excluded - worker activities unknown
Searl and Robertson (2005) - 5d	Manufacture of XPS from XPS masterbatch	XPS foam	NR	Process operators handling XPS masterbatch	Mean: 0.03 90th percentile: 0.03	24	8-hr TWA	Original source: Searl and Robertson (2005) Reported in: (ECHA 2008b); (ECHA 2009b)	3809166	High	Excluded - EPA used the data in Searl and Robertson (2005) - 5a because it presents a larger range of potential exposure
Zhang et al. (2012) - 1a	Thermal cutting of XPS foam	XPS foam	NR	Thermal cutting of XPS boards in a closed glovebox	Mean: 0.089	NR	NR	(Zhang et al. 2012)	1927576	High	Excluded - sample time is unknown
Zhang et al. (2012) - 1b	Thermal cutting of EPS foam	EPS foam	NR	Thermal cutting of EPS boards in a closed glovebox	Mean: 0.057	NR	NR	(Zhang et al. 2012)	1927576	High	Excluded - sample time is unknown

NR = Not Reported; N/A = Not Applicable

a – Where multiple datasets were available from one literature source, EPA distinguished data as 1a, 1b, 2a, 2b, etc.

b - Statistics were calculated by the cited source and are presented here as they were presented in the source.

c – Where information is presented in multiple sources all sources are listed. Information was not combined from these sources but was presented in all sources independently.

E.7 Data Integration Strategy for Occupational Exposure and Release Data/ Information

General Approach

Data integration is the stage following the data extraction and evaluation step discussed in the Application of Systematic Review in TSCA Risk Evaluations ([U.S. EPA 2018b](#)). Data integration is where the analysis, synthesis and integration of data/ information takes place. For integration of occupational exposure and environmental release data/information, EPA will normally use the highest rated quality data among the higher level of the hierarchy of preferences as described below. Table_Apx E-12 and Table_Apx E-13 below present the hierarchy of preferences among the primary types of data/ information to be analyzed, synthesized and integrated for the occupational exposure and release assessments in the TSCA Risk Evaluations. EPA will provide rationale when deviations from the hierarchy occur.

Selection of Data and Approaches

EPA will select data for use from the data extraction and evaluation phase of systematic review. EPA will only use data/information rated as High, Medium, or Low in the environmental release and occupational exposure assessments; data/ information rated as unacceptable will not be used. If need be, data of lower rated quality or approaches in lower levels of the hierarchy may be used to supplement the analysis. For example, data/ information of high quality could be determined to be sufficient such that lower quality data may not be included or integrated with the higher quality data. Also, data/ information of high quality could be determined to be sufficient such that approaches assigned lower preference levels in the hierarchy may not be pursued even if they are available and possible. In many cases, EPA does not have robust and/or representative monitoring data and will augment such data with modeled estimates of exposure.

Assessment Data and Results

EPA will provide occupational exposure and environmental release data and results representative of *central tendency* conditions and *high-end* conditions. A central tendency is assumed to be representative of occupational exposures and environmental releases in the center of the distribution for a given condition of use. For Risk Evaluation, EPA may use the 50th percentile (median), mean (arithmetic or geometric), mode, or midpoint values of a distribution as representative of the central tendency scenario. EPA's preference is to provide the 50th percentile of the distribution. However, if the full distribution is not known, EPA may assume that the mean, mode, or midpoint of the distribution represents the central tendency depending on the statistics available for the distribution.

A high-end is assumed to be representative of occupational exposures and environmental releases that occur at probabilities above the 90th percentile but below the exposure of the individual with the highest exposure ([U.S. EPA, 1992](#)) or the highest release. For Risk Evaluation, EPA plans to provide high-end results at the 95th percentile. If the 95th percentile is not available, EPA may use a different percentile greater than or equal to the 90th percentile but less than or equal to the 99.9th percentile, depending on the statistics available for the

distribution. If the full distribution is not known and the preferred statistics are not available, EPA may estimate a maximum or bounding estimate in lieu of the high-end.

EPA has defined occupational exposure and environmental release scenarios (OEERS) as the most granular level that EPA will generate results within each condition of use. For some conditions of use, EPA may define only a single OEERS (*e.g.*, a manufacturing condition of use for multiple manufacturing sites may be defined by a single manufacturing OEERS). Other conditions of use have multiple OEERS (*e.g.*, the use of chemical X in vapor degreasing has OEERS for open-top batch vapor degreasing, conveyORIZED degreasing, web degreasing, and closed-system degreasing). EPA will attempt to provide a single set of results (central tendency and high-end) for each release or exposure assessed for an OEERS.

Integration of Data Sets

To provide the occupational and environmental release results at the central tendency and high-end descriptors, EPA may integrate data sets representative of different sites, job descriptions, or process conditions to develop a distribution representative of the entire population of workers and sites involved in the given OEERS in the United States. Ideally, the distribution would account for inter-site variability (variability in operations among different sites) and intra-site variability (variability in operations within a single site).

To integrate data sets together, EPA will review the available metadata for each data set to ensure the data sets are representative of the same OEERS. EPA will document any uncertainties in the metadata or if EPA used a data set of a similar scenario as surrogate for the OEERS being assessed.

Integration of Data for Modeling and Calculations

For occupational exposures, EPA may use measured or estimated air concentrations to calculate exposure concentration metrics required for risk assessment, such as average daily concentration and lifetime average daily concentration. These calculations require additional parameter inputs, such as years of exposure, exposure duration and frequency, and lifetime years. EPA may estimate exposure concentrations from monitoring data, modeling, or occupational exposure limits, as identified in Table_Apx E-12 and use each of these in its evidence integration to assess the strength of the evidence.

For the final exposure result metrics, each of the input parameters (*e.g.*, air concentrations, working years, exposure frequency, lifetime years) may be a *point estimate* (*i.e.*, a single descriptor or statistic, such as 50th percentile or 95th percentile) or a *full distribution*. EPA will consider three general approaches for estimating the final exposure result metrics:

- **Deterministic calculations:** EPA will use combinations of point estimates of each parameter to estimate a central tendency and high-end for each final exposure metric result. EPA will document the method and rationale for selecting parametric combinations to be representative of central tendency and high-end.

- Probabilistic (stochastic) calculations: EPA will pursue Monte Carlo simulations using the full distribution of each parameter to calculate a full distribution of the final exposure metric results and selecting the 50th and 95th percentiles of this resulting distribution as the central tendency and high-end, respectively.
- Combination of deterministic and probabilistic calculations: EPA may have full distributions for some parameters but point estimates of the remaining parameters. For example, EPA may pursue Monte Carlo modeling to estimate exposure concentrations, but only have point estimates of working years of exposure, exposure duration and frequency, and lifetime years. In this case, EPA will document the approach and rationale for combining point estimates with distribution results for estimating central tendency and high-end results.
 - Probabilistic approaches can also supplement and complement monitoring estimates by providing sensitivity analysis of parameters for certain conditions and thus provide greater certainty about the strength of the evidence.

Confidence Statements

For each use, EPA considered the assessment approach, the quality of the data and models, and uncertainties in assessment results to determine a level of confidence for the 8-hr TWA data and modeled estimates.

For the inhalation air concentration monitoring data, strength of confidence is improved by the following factors:

- higher approaches in the inhalation approach hierarchy
- larger numbers of data points
- larger number of sites monitored
- larger broadness of worker population groups included in monitoring
- higher systematic review data quality ratings.

Strength of confidence in monitoring data is reduced by:

- uncertainty of the representativeness of these data toward the true distribution of inhalation concentrations for the industries and sites covered by the use.

For modeled air concentrations, strength of confidence is improved by the following factors:

- higher approaches in the inhalation approach hierarchy
- model validation
- full distributions of input parameters.

Strength of confidence in modeled air concentration estimates is reduced by:

- uncertainty of the representativeness of the model or parameter inputs toward the true distribution of inhalation concentrations for the industries and sites covered by the use.

Table_Apx E-12. Hierarchy guiding integration of occupational exposure data/information

For occupational exposures, the generic hierarchy of preferences, listed from highest to lowest levels, is as follows (and may be modified based on the assessment):

<p>Highest Preferred</p> 	<ol style="list-style-type: none"> 1. Monitoring data: <ol style="list-style-type: none"> a. Personal and directly applicable b. Area and directly applicable c. Personal and potentially applicable or similar d. Area and potentially applicable or similar
	<ol style="list-style-type: none"> 2. Modeling approaches: <ol style="list-style-type: none"> a. Surrogate monitoring data: Modeling exposure for chemical “X” and condition of use “A” based on observed monitoring data for chemical “Y” and condition of use “A”, assuming a known relationship (<i>e.g.</i>, a linear relationship) between observed exposure and physical property (<i>e.g.</i>, vapor pressure). b. Fundamental modeling approaches: Modeling exposure for chemical “X” for condition of use “A” based on fundamental mass transfer, thermodynamic, and kinetic phenomena for chemical “X” and data for condition of use “A” c. Fundamental modeling approaches (with surrogacy): A modeling approach following item 2.b, but using surrogate data in the model, such as data for condition of use “B” judged to be similar to condition of use “A” d. Statistical regression modeling approaches: Modeling exposure for chemical “X” in condition of use “A” using a statistical regression model developed based on: <ol style="list-style-type: none"> i. Observed monitoring data for chemical “X” statistically correlated with observed data specific for condition of use “B” judged to be similar to condition of use “A” such that replacement of input values in the model can extrapolate exposure results to condition of use “A” ii. Observed monitoring data for chemical “Y” statistically correlated with physical properties and/or molecular structure such that an exposure prediction for chemical “X” can be made (<i>e.g.</i>, QSAR techniques)
<p>Lowest Preferred</p>	<ol style="list-style-type: none"> 3. Occupational exposure limits (OELs): <ol style="list-style-type: none"> a. Company-specific OELs (for site-specific exposure assessments, <i>e.g.</i>, there is only one manufacturer who provides to EPA their internal OEL but does not provide monitoring data) b. OSHA PEL c. Voluntary limits (ACGIH TLV, NIOSH REL, OARS WEEL [formerly by AIHA])

Table_Apx E-13. Hierarchy guiding integration of environmental release data/information

For environmental releases, the generic hierarchy of preferences, listed from highest to lowest levels, is as follows (and may be modified based on the assessment):

<p>Highest Preferred</p> 	<ol style="list-style-type: none"> 1. Monitoring and measured data: <ol style="list-style-type: none"> a. Releases calculated from site-specific concentration in medium and flow rate data (<i>e.g.</i>, concentration in and flow rate of wastewater effluent discharged through outfall) b. Releases calculated from mass balances or emission factor methods using site-specific measured data (<i>e.g.</i>, process flow rates and concentrations)
	<ol style="list-style-type: none"> 2. Modeling approaches: <ol style="list-style-type: none"> a. Surrogate monitoring data: Modeling release for chemical “X” and condition of use “A” based on observed monitoring data for chemical “Y” and condition of use “A”, assuming a known relationship (<i>e.g.</i>, a linear relationship) between observed release and physical property (<i>e.g.</i>, vapor pressure) b. Fundamental modeling approaches: Modeling release for chemical “X” for condition of use “A” based on fundamental mass transfer, thermodynamic, and kinetic phenomena for chemical “X” and data for condition of use “A” c. Fundamental modeling approaches (with surrogacy): A modeling approach following item 2.b, but using surrogate data in the model, such as data for condition of use “B” judged to be similar to condition of use “A” d. Statistical regression modeling approaches: Modeling release for chemical “X” in condition of use “A” using a statistical regression model developed based on: <ol style="list-style-type: none"> iii. Observed monitoring data for chemical “X” statistically correlated with observed data specific for condition of use “B” judged to be similar to condition of use “A” such that replacement of input values in the model can extrapolate exposure results to condition of use “A” iv. Observed monitoring data for chemical “Y” statistically correlated with physical properties and/or molecular structure such that a release prediction for chemical “X” can be made (<i>e.g.</i>, QSAR techniques)
<p>Lowest Preferred</p>	<ol style="list-style-type: none"> 3. Release limits: <ol style="list-style-type: none"> a. Company-specific limits (for site-specific exposure assessments, <i>e.g.</i>, there is only one manufacturer who provides to EPA their internal limits (<i>e.g.</i>, point-source permits) but does not provide monitoring data) b. NESHAP or effluent limitations/ requirements

E.8 Information on the Age of Employed Persons

For occupational exposures, EPA assessed exposures to workers and ONUs. Table_Apx E-14 presents the percentage of employed workers and ONUs who may be susceptible subpopulations within select industry sectors relevant to HBCD conditions of use. The percentages were calculated using Current Population Survey (CPS) data for 2017. CPS is a monthly survey of households conducted by the Bureau of Census for the Bureau of Labor Statistics (BLS) and provides a comprehensive body of data on the labor force characteristics. Statistics for the following subpopulations of workers and ONUs are provided: individuals age 16 to 19, men and women of reproductive age,²³ and the elderly. CPS considers “reproductive age” as age 16 to 54. As shown in Table_Apx E-14, men make up the majority of the workforce in the construction and manufacturing sectors. In other sectors, women (including those of reproductive age and elderly women) make up nearly half of the workforce.

Adolescents (16 to <21 years old) appear to be generally a small part of the total workforce based on CPS data for employed individuals between 16 and 19 years of age. Table_Apx E-15 presents further breakdown on this subset of adolescents employed by industry subsectors. As shown in the table, they comprise less than two percent of the workforce. These data do not cover all adolescents in the HBCD workforce because of the different age range used by the BLS.

Table_Apx E-14. Percentage of Employed Persons by Age, Sex, and Industry Sector

Age Group	Sex	Construction	Manufacturing	Wholesale and retail trade	Professional and business services
Adolescent (16-19 years)	Male	1.7%	0.8%	3.0%	0.7%
	Female	0.1%	0.4%	3.2%	0.5%
Reproductive Age (16-54 years)	Male	72.2%	52.9%	42.8%	44.4%
	Female	6.8%	22.2%	35.4%	32.8%
Elderly (55+)	Male	18.8%	17.5%	12.3%	13.4%
	Female	2.3%	7.3%	9.6%	9.4%

Source: ([U.S. BLS, 2017](#)). Percentage calculated using CPS table 14, “Employed persons in nonagricultural industries by age, sex, race, and Hispanic or Latino ethnicity.”

Table_Apx E-15. Percentage of Employed Persons Age 16-19 Years by Detailed Industry Sector

Sector	Subsector	Adolescents (16-19 years)
Construction (No subsectors)	All	1.82%
Manufacturing	All	1.21%
Wholesale and retail trade	Wholesale trade	1.36%
Professional and business services	Waste management and remediation services	0.93%

Source: ([U.S. BLS, 2017](#)). Percentage calculated using CPS table 18b, “Employed persons by detailed industry and age.”

The CPS uses 2012 Census industry classification, which was derived from the 2012 NAICS. The Census classification uses the same basic structure as NAICS but is generally less detailed. HBCD conditions of use fall under the following Census industry sectors:

²³ While statistics on pregnant women are not available, CPS provides data on the number of employed female workers by age group, which allows for determination of the number of employed women of reproductive age.

- Construction – The Construction sector comprises establishments primarily engaged in the construction of buildings or engineering projects (*e.g.*, highways and utility systems). Establishments primarily engaged in the preparation of sites for new construction and establishments primarily engaged in subdividing land for sale as building sites also are included in this sector. Construction work done may include new work, additions, alterations, or maintenance and repairs. For HBCD, this sector covers the conditions of use for Installation of XPS/EPS Foam Insulation in Residential, Public and Commercial Buildings, and Other Structures and Demolition and Disposal of XPS/EPS Foam Insulation Products in Residential, Public and Commercial Buildings, and Other Structures.
- Manufacturing – The Manufacturing sector comprises establishments engaged in the mechanical, physical, or chemical transformation of materials, substances, or components into new products. Establishments in the sector are often described as plants, factories, or mills. For HBCD, this sector covers conditions of use that occur in an industrial setting, including: Compounding of Polystyrene Resin to Produce XPS Masterbatch, Processing of HBCD to Produce XPS Foam using XPS Masterbatch, Processing of HBCD to Produce XPS Foam Using HBCD Powder, Processing of HBCD to Produce EPS Foam from Imported EPS Resin Beads, Processing of HBCD to Produce SIPs and Automobile Replacement Parts from XPS/EPS Foam, Recycling of EPS Foam and Reuse of XPS Foam, Formulation of Flux/Solder Pastes, and Use of Flux/Solder Paste.
- Wholesale and retail trade – The wholesale trade sector comprises establishments engaged in wholesaling merchandise, generally without transformation, and rendering services incidental to the sale of merchandise. Wholesalers normally operate from a warehouse or office. This sector likely covers facilities that are engaged in the importation of HBCD or EPS resin beads containing HBCD. The retail trade sector comprises establishments engaged in retailing merchandise and rendering services incidental to the sale of merchandise.
- Professional and business services – This sector comprises establishments that specialize in a wide range of services. This sector covers waste management and remediation services, which includes Recycling of Electronics Waste (E-Waste) Containing HIPS.

Appendix F ENVIRONMENTAL EXPOSURES

F.1 Modeled Exposure Scenarios Across Conditions of Use

F.1.1 Water Releases

Table_Apx F-1. Scenarios Used Across Conditions of Use for Water Releases of HBCD

Scenario Label	Condition of Use	Type of Water Release ^a [SIC]	WWTP %	Emission Factor ^b	Characterization of Emission Factor	Number of Release Days ^c	Release Days	Daily Release (kg/site/day)
1.1	Repackaging of import containers	On-site WWT [Plastic Resins]	90	Lower Value	Dust emissions factor for coarse particles (>40 µm)	Lower Value	29	1.6E+00
1.2	Repackaging of import containers	On-site WWT [Plastic Resins]	90	Lower Value	Dust emissions factor for coarse particles (>40 µm)	Higher Value	300	1.5E-01
1.3	Repackaging of import containers	On-site WWT [Plastic Resins]	90	Higher Value	Dust emissions factor for fine particles (<40 µm)	Lower Value	29	7.8E+00
1.4	Repackaging of import containers	On-site WWT [Plastic Resins]	90	Higher Value	Dust emissions factor for fine particles (<40 µm)	Higher Value	300	7.6E-01
1.5	Repackaging of import containers	POTW [Ind POTW]	90	Lower Value	Dust emissions factor for coarse particles (>40 µm)	Lower Value	29	1.6E+00
1.6	Repackaging of import containers	POTW [Ind POTW]	90	Lower Value	Dust emissions factor for coarse particles (>40 µm)	Higher Value	300	1.5E-01
1.7	Repackaging of import containers	POTW [Ind POTW]	90	Higher Value	Dust emissions factor for fine particles (<40 µm)	Lower Value	29	7.8E+00
1.8	Repackaging of import containers	POTW [Ind POTW]	90	Higher Value	Dust emissions factor for fine particles (<40 µm)	Higher Value	300	7.6E-01
2.1	Compounding of Polystyrene Resin to Produce XPS Masterbatch	Surface Water	0	Lower Value	Average calculated emission factor from EURAR data	Lower Value	10	1.5E-01
2.2	Compounding of Polystyrene Resin to Produce XPS Masterbatch	Surface Water	0	Lower Value	Average calculated emission factor from EURAR data	Higher Value	60	2.4E-02
2.3	Compounding of Polystyrene Resin to Produce XPS Masterbatch	Surface Water	0	Higher Value	EURAR's 'worst-case' emission factor	Lower Value	10	3.4E-01

Scenario Label	Condition of Use	Type of Water Release ^a [SIC]	WWTP %	Emission Factor ^b	Characterization of Emission Factor	Number of Release Days ^c	Release Days	Daily Release (kg/site/day)
2.4	Compounding of Polystyrene Resin to Produce XPS Masterbatch	Surface Water	0	Higher Value	EURAR's 'worst-case' emission factor	Higher Value	60	5.6E-02
2.5	Compounding of Polystyrene Resin to Produce XPS Masterbatch	On-site WWT [Plastic Resins]	90	Lower Value	Average calculated emission factor from EURAR data	Lower Value	10	1.5E-01
2.6	Compounding of Polystyrene Resin to Produce XPS Masterbatch	On-site WWT [Plastic Resins]	90	Lower Value	Average calculated emission factor from EURAR data	Higher Value	60	2.4E-02
2.7	Compounding of Polystyrene Resin to Produce XPS Masterbatch	On-site WWT [Plastic Resins]	90	Higher Value	EURAR's 'worst-case' emission factor	Lower Value	10	3.4E-01
2.8	Compounding of Polystyrene Resin to Produce XPS Masterbatch	On-site WWT [Plastic Resins]	90	Higher Value	EURAR's 'worst-case' emission factor	Higher Value	60	5.6E-02
2.9	Compounding of Polystyrene Resin to Produce XPS Masterbatch	POTW [Ind POTW]	90	Lower Value	Average calculated emission factor from EURAR data	Lower Value	10	1.5E-01
2.10	Compounding of Polystyrene Resin to Produce XPS Masterbatch	POTW [Ind POTW]	90	Lower Value	Average calculated emission factor from EURAR data	Higher Value	60	2.4E-02
2.11	Compounding of Polystyrene Resin to Produce XPS Masterbatch	POTW [Ind POTW]	90	Higher Value	EURAR's 'worst-case' emission factor	Lower Value	10	3.4E-01
2.12	Compounding of Polystyrene Resin to Produce XPS Masterbatch	POTW [Ind POTW]	90	Higher Value	EURAR's 'worst-case' emission factor	Higher Value	60	5.6E-02
3.1	3. Manufacturing of XPS Foam using XPS Masterbatch	Surface Water	0	Lower Value	Average calculated emission factor from EURAR data	Lower Value	1	4.9E-01
3.2	3. Manufacturing of XPS Foam using XPS Masterbatch	Surface Water	0	Lower Value	Average calculated emission factor from EURAR data	Higher Value	15	3.2E-02
3.3	3. Manufacturing of XPS Foam using XPS Masterbatch	Surface Water	0	Higher Value	EURAR's 'worst-case' emission factor	Lower Value	1	1.2E+00

Scenario Label	Condition of Use	Type of Water Release ^a [SIC]	WWTP %	Emission Factor ^b	Characterization of Emission Factor	Number of Release Days ^c	Release Days	Daily Release (kg/site/day)
3.4	3. Manufacturing of XPS Foam using XPS Masterbatch	Surface Water	0	Higher Value	EURAR's 'worst-case' emission factor	Higher Value	15	8.0E-02
3.5	3. Manufacturing of XPS Foam using XPS Masterbatch	On-site WWT [Plastic Resins]	90	Lower Value	Average calculated emission factor from EURAR data	Lower Value	1	4.9E-01
3.6	3. Manufacturing of XPS Foam using XPS Masterbatch	On-site WWT [Plastic Resins]	90	Lower Value	Average calculated emission factor from EURAR data	Higher Value	15	3.2E-02
3.7	3. Manufacturing of XPS Foam using XPS Masterbatch	On-site WWT [Plastic Resins]	90	Higher Value	EURAR's 'worst-case' emission factor	Lower Value	1	1.2E+00
3.8	3. Manufacturing of XPS Foam using XPS Masterbatch	On-site WWT [Plastic Resins]	90	Higher Value	EURAR's 'worst-case' emission factor	Higher Value	15	8.0E-02
3.9	3. Manufacturing of XPS Foam using XPS Masterbatch	POTW [Ind POTW]	90	Lower Value	Average calculated emission factor from EURAR data	Lower Value	1	4.9E-01
3.10	3. Manufacturing of XPS Foam using XPS Masterbatch	POTW [Ind POTW]	90	Lower Value	Average calculated emission factor from EURAR data	Higher Value	15	3.2E-02
3.11	3. Manufacturing of XPS Foam using XPS Masterbatch	POTW [Ind POTW]	90	Higher Value	EURAR's 'worst-case' emission factor	Lower Value	1	1.2E+00
3.12	Manufacturing of XPS Foam using XPS Masterbatch	POTW [Ind POTW]	90	Higher Value	EURAR's 'worst-case' emission factor	Higher Value	15	8.0E-02
4.1	Manufacturing of XPS Foam using HBCD Powder	Surface Water	0	-	Average calculated emission factor from EURAR data	Lower Value	1	4.6E-01
4.2	Manufacturing of XPS Foam using HBCD Powder	Surface Water	0	-	Average calculated emission factor from EURAR data	Higher Value	12	3.9E-02
4.3	Manufacturing of XPS Foam using HBCD Powder	On-site WWT [Plastic Resins]	90	-	Average calculated emission factor from EURAR data	Lower Value	1	4.6E-01
4.4	Manufacturing of XPS Foam using HBCD Powder	On-site WWT [Plastic Resins]	90	-	Average calculated emission factor from EURAR data	Higher Value	12	3.9E-02

Scenario Label	Condition of Use	Type of Water Release ^a [SIC]	WWTP %	Emission Factor ^b	Characterization of Emission Factor	Number of Release Days ^c	Release Days	Daily Release (kg/site/day)
4.5	Manufacturing of XPS Foam using HBCD Powder	POTW [Ind POTW]	90	-	Average calculated emission factor from EURAR data	Lower Value	1	4.6E-01
4.6	Manufacturing of XPS Foam using HBCD Powder	POTW [Ind POTW]	90	-	Average calculated emission factor from EURAR data	Higher Value	12	3.9E-02
5.1	Manufacturing of EPS Foam from Imported EPS Resin beads	Surface Water	0	Lower Value	Dust emissions during converting process emission factor (lower) and EPA/OPPT Solid Residuals in Transport Containers Model emission factor	Lower Value	16	3.1E+01
5.2	Manufacturing of EPS Foam from Imported EPS Resin beads	On-site WWT [Plastic Resins]	90	Lower Value	Dust emissions during converting process emission factor (lower) and EPA/OPPT Solid Residuals in Transport Containers Model emission factor	Lower Value	16	3.1E+01
5.3	Manufacturing of EPS Foam from Imported EPS Resin beads	POTW [Ind POTW]	90	Lower Value	Dust emissions during converting process emission factor (lower) and EPA/OPPT Solid Residuals in Transport Containers Model emission factor	Lower Value	16	3.1E+01
5.4	Manufacturing of EPS Foam from Imported EPS Resin beads	Surface Water	0	Lower Value	Dust emissions during converting process emission factor (lower) and EPA/OPPT Solid Residuals in Transport Containers Model emission factor	Higher Value	140	3.6E+00
5.5	Manufacturing of EPS Foam from Imported EPS Resin beads	On-site WWT [Plastic Resins]	90	Lower Value	Dust emissions during converting process emission factor (lower) and EPA/OPPT Solid	Higher Value	140	3.6E+00

Scenario Label	Condition of Use	Type of Water Release ^a [SIC]	WWTP %	Emission Factor ^b	Characterization of Emission Factor	Number of Release Days ^c	Release Days	Daily Release (kg/site/day)
					Residuals in Transport Containers Model emission factor			
5.6	Manufacturing of EPS Foam from Imported EPS Resin beads	POTW [Ind POTW]	90	Lower Value	Dust emissions during converting process emission factor (lower) and EPA/OPPT Solid Residuals in Transport Containers Model emission factor	Higher Value	140	3.6E+00
5.7	Manufacturing of EPS Foam from Imported EPS Resin beads	Surface Water	0	Higher Value	Dust emissions during converting process emission factor (higher) and EPA/OPPT Solid Residuals in Transport Containers Model emission factor	Lower Value	16	4.2E+01
5.8	Manufacturing of EPS Foam from Imported EPS Resin beads	On-site WWT [Plastic Resins]	90	Higher Value	Dust emissions during converting process emission factor (higher) and EPA/OPPT Solid Residuals in Transport Containers Model emission factor	Lower Value	16	4.2E+01
5.9	Manufacturing of EPS Foam from Imported EPS Resin beads	POTW [Ind POTW]	90	Higher Value	Dust emissions during converting process emission factor (higher) and EPA/OPPT Solid Residuals in Transport Containers Model emission factor	Lower Value	16	4.2E+01
5.10	Manufacturing of EPS Foam from Imported EPS Resin beads	Surface Water	0	Higher Value	Dust emissions during converting process emission factor (higher) and EPA/OPPT Solid Residuals in Transport Containers Model emission factor	Higher Value	140	4.9E+00

Scenario Label	Condition of Use	Type of Water Release ^a [SIC]	WWTP %	Emission Factor ^b	Characterization of Emission Factor	Number of Release Days ^c	Release Days	Daily Release (kg/site/day)
5.11	Manufacturing of EPS Foam from Imported EPS Resin beads	On-site WWT [Plastic Resins]	90	Higher Value	Dust emissions during converting process emission factor (higher) and EPA/OPPT Solid Residuals in Transport Containers Model emission factor	Higher Value	140	4.9E+00
5.12	Manufacturing of EPS Foam from Imported EPS Resin beads	POTW [Ind POTW]	90	Higher Value	Dust emissions during converting process emission factor (higher) and EPA/OPPT Solid Residuals in Transport Containers Model emission factor	Higher Value	140	4.9E+00
6.1	Manufacturing of SIPs and Automobile Replacement Parts	Surface Water	0	Lower Value	Dust release during cutting of foam	Lower Value	16	1.4E-01
6.2	Manufacturing of SIPs and Automobile Replacement Parts	On-site WWT [Plastic Resins]	90	Lower Value	Dust release during cutting of foam	Lower Value	16	1.4E-01
6.3	Manufacturing of SIPs and Automobile Replacement Parts	POTW [Ind POTW]	90	Lower Value	Dust release during cutting of foam	Lower Value	16	1.4E-01
6.4	Manufacturing of SIPs and Automobile Replacement Parts	Surface Water	0	Lower Value	Dust release during cutting of foam	Higher Value	300	7.6E-03
6.5	Manufacturing of SIPs and Automobile Replacement Parts	On-site WWT [Plastic Resins]	90	Lower Value	Dust release during cutting of foam	Higher Value	300	7.6E-03
6.6	Manufacturing of SIPs and Automobile Replacement Parts	POTW [Ind POTW]	90	Lower Value	Dust release during cutting of foam	Higher Value	300	7.6E-03
6.7	Manufacturing of SIPs and Automobile Replacement Parts	Surface Water	0	Higher Value	Dust release during sawing of foam	Lower Value	16	6.4E-01

Scenario Label	Condition of Use	Type of Water Release ^a [SIC]	WWTP %	Emission Factor ^b	Characterization of Emission Factor	Number of Release Days ^c	Release Days	Daily Release (kg/site/day)
6.8	Manufacturing of SIPs and Automobile Replacement Parts	On-site WWT [Plastic Resins]	90	Higher Value	Dust release during sawing of foam	Lower Value	16	6.4E-01
6.9	Manufacturing of SIPs and Automobile Replacement Parts	POTW [Ind POTW]	90	Higher Value	Dust release during sawing of foam	Lower Value	16	6.4E-01
6.1	Manufacturing of SIPs and Automobile Replacement Parts	Surface Water	0	Higher Value	Dust release during sawing of foam	Higher Value	300	3.4E-02
6.11	Manufacturing of SIPs and Automobile Replacement Parts	On-site WWT [Plastic Resins]	90	Higher Value	Dust release during sawing of foam	Higher Value	300	3.4E-02
6.12	Manufacturing of SIPs and Automobile Replacement Parts	POTW [Ind POTW]	90	Higher Value	Dust release during sawing of foam	Higher Value	300	3.4E-02
8.1	Installation of Insulation in Buildings	Surface water	0	Lower Value	Dust release during cutting of foam	Lower Value	1	8.5E-04
8.2	Installation of Insulation in Buildings	POTW [Ind POTW]	90	Lower Value	Dust release during cutting of foam	Lower Value	1	8.5E-04
8.3	Installation of Insulation in Buildings	Surface water	0	Higher Value	Dust release during sawing of foam	Higher Value	3	0.10
8.4	Installation of Insulation in Buildings	POTW [Ind POTW]	90	Higher Value	Dust release during sawing of foam	Higher Value	3	0.10
9.1	Generation of foam particles during demolition	Surface Water	0	Lower Value	Dust release during breaking of foam	Lower Value	1	7.57E-04
9.2	Generation of foam particles during demolition	Surface Water	0	Higher Value	Dust release during breaking of foam	Lower Value	1	0.675
9.3	Generation of foam particles during demolition	POTW [Ind POTW]	90	Lower Value	Dust release during breaking of foam	Lower Value	1	7.57E-04
9.4	Generation of foam particles during demolition	POTW [Ind POTW]	90	Higher Value	Dust release during breaking of foam	Lower Value	1	0.675

Scenario Label	Condition of Use	Type of Water Release ^a [SIC]	WWTP %	Emission Factor ^b	Characterization of Emission Factor	Number of Release Days ^c	Release Days	Daily Release (kg/site/day)
10.1	Recycling of EPS Foam	surface water	0	Lower Value	Dust emissions during recycling process emission factor (lower) and EPA/OPPT Solid Residuals in Transport Containers Model emission factor	Lower Value	1	6.7E-01
10.2	Recycling of EPS Foam	On-site WWT [Plastic Resins]	90	Lower Value	Dust emissions during recycling process emission factor (lower) and EPA/OPPT Solid Residuals in Transport Containers Model emission factor	Lower Value	1	6.7E-01
10.3	Recycling of EPS Foam	POTW [Ind POTW]	90	Lower Value	Dust emissions during recycling process emission factor (lower) and EPA/OPPT Solid Residuals in Transport Containers Model emission factor	Lower Value	1	6.7E-01
10.4	Recycling of EPS Foam	Surface Water	0	Lower Value	Dust emissions during recycling process emission factor (lower) and EPA/OPPT Solid Residuals in Transport Containers Model emission factor	Higher Value	140	4.8E-03
10.5	Recycling of EPS Foam	On-site WWT [Plastic Resins]	90	Lower Value	Dust emissions during recycling process emission factor (lower) and EPA/OPPT Solid Residuals in Transport Containers Model emission factor	Higher Value	140	4.8E-03
10.6	Recycling of EPS Foam	POTW [Ind POTW]	90	Lower Value	Dust emissions during recycling process emission factor (lower) and EPA/OPPT Solid Residuals in Transport Containers Model emission factor	Higher Value	140	4.8E-03

Scenario Label	Condition of Use	Type of Water Release ^a [SIC]	WWTP %	Emission Factor ^b	Characterization of Emission Factor	Number of Release Days ^c	Release Days	Daily Release (kg/site/day)
10.7	Recycling of EPS Foam	Surface Water	0	Higher Value	Dust emissions during recycling process emission factor (higher) and EPA/OPPT Solid Residuals in Transport Containers Model emission factor	Lower Value	1	7.9E-01
10.8	Recycling of EPS Foam	On-site WWT [Plastic Resins]	90	Higher Value	Dust emissions during recycling process emission factor (higher) and EPA/OPPT Solid Residuals in Transport Containers Model emission factor	Lower Value	1	7.9E-01
10.9	Recycling of EPS Foam	POTW [Ind POTW]	90	Higher Value	Dust emissions during recycling process emission factor (higher) and EPA/OPPT Solid Residuals in Transport Containers Model emission factor	Lower Value	1	7.9E-01
10.1	Recycling of EPS Foam	Surface Water	0	Higher Value	Dust emissions during recycling process emission factor (higher) and EPA/OPPT Solid Residuals in Transport Containers Model emission factor	Higher Value	140	5.7E-03
10.11	Recycling of EPS Foam	On-site WWT [Plastic Resins]	90	Higher Value	Dust emissions during recycling process emission factor (higher) and EPA/OPPT Solid Residuals in Transport Containers Model emission factor	Higher Value	140	5.7E-03
10.12	Recycling of EPS Foam	POTW [Ind POTW]	90	Higher Value	Dust emissions during recycling process emission factor (higher) and EPA/OPPT Solid Residuals in Transport Containers Model emission factor	Higher Value	140	5.7E-03

Scenario Label	Condition of Use	Type of Water Release ^a [SIC]	WWTP %	Emission Factor ^b	Characterization of Emission Factor	Number of Release Days ^c	Release Days	Daily Release (kg/site/day)
12.1	Use of Solder	On-site WWT [Plastic Resins]	90	Lower Value	Equipment cleaning emission factor (lower) (OECD 2010a)	Lower Value	4	2.5E-02
12.2	Use of Solder	POTW [Ind POTW]	90	Lower Value	Equipment cleaning emission factor (lower) (OECD 2010a)	Lower Value	4	2.5E-02
12.3	Use of Solder	On-site WWT [Plastic Resins]	90	Lower Value	Equipment cleaning emission factor (lower) (OECD 2010a)	Higher Value	300	3.3E-04
12.4	Use of Solder	POTW [Ind POTW]	90	Lower Value	Equipment cleaning emission factor (lower) (OECD 2010a)	Higher Value	300	3.3E-04
12.5	Use of Solder	On-site WWT [Plastic Resins]	90	Higher Value	Equipment cleaning emission factor (higher) (OECD 2010a)	Lower Value	4	5.0E-02
12.6	Use of Solder	POTW [Ind POTW]	90	Higher Value	Equipment cleaning emission factor (higher) (OECD 2010a)	Lower Value	4	5.0E-02
12.7	Use of Solder	On-site WWT [Plastic Resins]	90	Higher Value	Equipment cleaning emission factor (higher) (OECD 2010a)	Higher Value	300	6.7E-04
12.8	Use of Solder	POTW [Ind POTW]	90	Higher Value	Equipment cleaning emission factor (higher) (OECD 2010a)	Higher Value	300	6.7E-04

^aFor each release source, water releases were modeled depending on the potential for the release to go directly to surface water, to an on-site wastewater treatment or publicly owned treatment works.

^bWhere identified in literature, EPA utilized a range of emission factors with the characterization of those emission factor described in further details in Section 2.2.

^cWhere identified in literature, EPA utilized a range of release days based on the specific condition of use as discussed further in Section 2.2.

F.1.2 Air Releases

Table_Apx F-2. Scenarios Used Across Conditions of Use for Air Releases of HBCD

Scenario Label	Conditions of Use	Type of Air Release	Characterization of Emission Factor	Emission Factor	Release Days	Number of Release Days	Daily Release (kg/site/day)
1.1	Import/Repackaging	Fugitive	Dust release during unloading of HBCD	lower value	lower value	29	1.6E+00
1.2	Import/Repackaging	Fugitive	Dust release during unloading of HBCD	lower value	higher value	300	1.5E-01
1.3	Import/Repackaging	Fugitive	Dust release during unloading of HBCD	upper value	lower value	29	7.8E+00

Scenario Label	Conditions of Use	Type of Air Release	Characterization of Emission Factor	Emission Factor	Release Days	Number of Release Days	Daily Release (kg/site/day)
1.4	Import/Repackaging	Fugitive	Dust release during unloading of HBCD	upper value	higher value	300	7.6E-01
1.5	Import/Repackaging	Stack	Dust release during unloading of HBCD	lower value	lower value	29	1.6E+00
1.6	Import/Repackaging	Stack	Dust release during unloading of HBCD	lower value	higher value	300	1.5E-01
1.7	Import/Repackaging	Stack	Dust release during unloading of HBCD	upper value	lower value	29	7.8E+00
1.8	Import/Repackaging	Stack	Dust release during unloading of HBCD	upper value	higher value	300	7.6E-01
1.9	Import/Repackaging	Incineration	Dust release during unloading of HBCD	lower value	lower value	29	1.6E+00
1.10	Import/Repackaging	Incineration	Dust release during unloading of HBCD	lower value	higher value	300	1.5E-01
1.11	Import/Repackaging	Incineration	Dust release during unloading of HBCD	upper value	lower value	29	7.8E+00
1.12	Import/Repackaging	Incineration	Dust release during unloading of HBCD	upper value	higher value	300	7.6E-01
2.1	Compounding of Polystyrene Resin to Produce XPS Masterbatch	fugitive	Average calculated emission factor from EURAR data	lower value	lower value	10	2.8E-02
2.2	Compounding of Polystyrene Resin to Produce XPS Masterbatch	fugitive	Average calculated emission factor from EURAR data	lower value	higher value	60	4.6E-03
2.3	Compounding of Polystyrene Resin to Produce XPS Masterbatch	fugitive	Average calculated emission factor from EURAR data	upper value	lower value	10	3.3E-02
2.4	Compounding of Polystyrene Resin to Produce XPS Masterbatch	fugitive	Average calculated emission factor from EURAR data	upper value	higher value	60	5.5E-03
2.5	Compounding of Polystyrene Resin to Produce XPS Masterbatch	stack	Average calculated emission factor from EURAR data	lower value	lower value	10	2.8E-02

Scenario Label	Conditions of Use	Type of Air Release	Characterization of Emission Factor	Emission Factor	Release Days	Number of Release Days	Daily Release (kg/site/day)
2.6	Compounding of Polystyrene Resin to Produce XPS Masterbatch	stack	Average calculated emission factor from EURAR data	lower value	higher value	60	4.6E-03
2.7	Compounding of Polystyrene Resin to Produce XPS Masterbatch	stack	Average calculated emission factor from EURAR data	upper value	lower value	10	3.3E-02
2.8	Compounding of Polystyrene Resin to Produce XPS Masterbatch	stack	Average calculated emission factor from EURAR data	upper value	higher value	60	5.5E-03
3.1	Manufacturing of XPS Foam using XPS Masterbatch	fugitive	Average calculated emission factor from EURAR data	central value	lower value	1	2.6E+00
3.2	Manufacturing of XPS Foam using XPS Masterbatch	fugitive	Average calculated emission factor from EURAR data	central value	higher value	16	1.6E-01
3.3	Manufacturing of XPS Foam using XPS Masterbatch	stack	Average calculated emission factor from EURAR data	central value	lower value	1	2.6E+00
3.4	Manufacturing of XPS Foam using XPS Masterbatch	stack	Average calculated emission factor from EURAR data	central value	higher value	16	1.6E-01
4.1	Manufacturing of XPS Foam using HBCD Powder	fugitive	Average calculated emission factor from EURAR data	central value	lower value	1	3.3E-01
4.2	Manufacturing of XPS Foam using HBCD Powder	fugitive	Average calculated emission factor from EURAR data	central value	higher value	16	2.1E-02
4.3	Manufacturing of XPS Foam using HBCD Powder	stack	Average calculated emission factor from EURAR data	central value	lower value	1	3.3E-01
4.4	Manufacturing of XPS Foam using HBCD Powder	stack	Average calculated emission factor from EURAR data	central value	higher value	16	2.1E-02
4.5	Manufacturing of XPS Foam using HBCD Powder	stack	TRI data	empirical value	lower value	1	1.8E+00
4.6	Manufacturing of XPS Foam using HBCD Powder	stack	TRI data	empirical value	higher value	16	1.1E-01

Scenario Label	Conditions of Use	Type of Air Release	Characterization of Emission Factor	Emission Factor	Release Days	Number of Release Days	Daily Release (kg/site/day)
4.7	Manufacturing of XPS Foam using HBCD Powder	incineration	TRI data	empirical value	lower value	1	3.1E+01
4.8	Manufacturing of XPS Foam using HBCD Powder	incineration	TRI data	empirical value	higher value	16	1.9E+00
4.9	Manufacturing of XPS Foam using HBCD Powder	stack	TRI data	empirical value	lower value	1	2.1E+01
4.10	Manufacturing of XPS Foam using HBCD Powder	stack	TRI data	empirical value	higher value	16	1.3E+00
4.11	Manufacturing of XPS Foam using HBCD Powder	incineration	TRI data	empirical value	lower value	1	2.3E+01
4.12	Manufacturing of XPS Foam using HBCD Powder	incineration	TRI data	empirical value	higher value	16	1.5E+00
5.1	Manufacturing of EPS Foam from Imported EPS Resin beads	stack	Dust release during converting process	lower value	lower value	16	2.8E+00
5.2	Manufacturing of EPS Foam from Imported EPS Resin beads	stack	Dust release during converting process	lower value	higher value	140	3.2E-01
5.3	Manufacturing of EPS Foam from Imported EPS Resin beads	stack	Dust release during converting process	upper value	lower value	16	1.4E+01
5.4	Manufacturing of EPS Foam from Imported EPS Resin beads	stack	Dust release during converting process	upper value	higher value	140	1.6E+00
5.5	Manufacturing of EPS Foam from Imported EPS Resin beads	fugitive	Dust release during converting process	lower value	lower value	16	2.8E+00
5.6	Manufacturing of EPS Foam from Imported EPS Resin beads	fugitive	Dust release during converting process	lower value	higher value	140	3.2E-01
5.7	Manufacturing of EPS Foam from Imported EPS Resin beads	fugitive	Dust release during converting process	upper value	lower value	16	1.4E+01

Scenario Label	Conditions of Use	Type of Air Release	Characterization of Emission Factor	Emission Factor	Release Days	Number of Release Days	Daily Release (kg/site/day)
5.8	Manufacturing of EPS Foam from Imported EPS Resin beads	fugitive	Dust release during converting process	upper value	higher value	140	1.6E+00
5.9	Manufacturing of EPS Foam from Imported EPS Resin beads	incineration	Dust release during converting process	lower value	lower value	16	6.0E+01
5.10	Manufacturing of EPS Foam from Imported EPS Resin beads	incineration	Dust release during converting process	lower value	higher value	140	6.8E+00
5.11	Manufacturing of EPS Foam from Imported EPS Resin beads	incineration	Dust release during converting process	upper value	lower value	16	1.1E+02
5.12	Manufacturing of EPS Foam from Imported EPS Resin beads	incineration	Dust release during converting process	upper value	higher value	140	1.3E+01
6.1	Manufacturing of SIPs and Automobile Replacement Parts	fugitive	Dust release during sawing / cutting of foam	lower value	lower value	16	1.4E-01
6.2	Manufacturing of SIPs and Automobile Replacement Parts	fugitive	Dust release during sawing / cutting of foam	lower value	higher value	300	7.6E-03
6.3	Manufacturing of SIPs and Automobile Replacement Parts	fugitive	Dust release during sawing / cutting of foam	upper value	lower value	16	6.4E-01
6.4	Manufacturing of SIPs and Automobile Replacement Parts	fugitive	Dust release during sawing / cutting of foam	upper value	higher value	300	3.4E-02
6.5	Manufacturing of SIPs and Automobile Replacement Parts	stack	Dust release during sawing / cutting of foam	lower value	lower value	16	1.4E-01
6.6	Manufacturing of SIPs and Automobile Replacement Parts	stack	Dust release during sawing / cutting of foam	lower value	higher value	300	7.6E-03
6.7	Manufacturing of SIPs and Automobile Replacement Parts	stack	Dust release during sawing / cutting of foam	upper value	lower value	16	6.4E-01

Scenario Label	Conditions of Use	Type of Air Release	Characterization of Emission Factor	Emission Factor	Release Days	Number of Release Days	Daily Release (kg/site/day)
6.8	Manufacturing of SIPs and Automobile Replacement Parts	stack	Dust release during sawing / cutting of foam	upper value	higher value	300	3.4E-02
6.9	Manufacturing of SIPs and Automobile Replacement Parts	incineration	Dust release during sawing / cutting of foam	lower value	lower value	16	2.8E+01
6.10	Manufacturing of SIPs and Automobile Replacement Parts	incineration	Dust release during sawing / cutting of foam	lower value	higher value	300	1.5E+00
6.11	Manufacturing of SIPs and Automobile Replacement Parts	incineration	Dust release during sawing / cutting of foam	upper value	lower value	16	7.2E+01
6.12	Manufacturing of SIPs and Automobile Replacement Parts	incineration	Dust release during sawing / cutting of foam	upper value	higher value	300	3.8E+00
8.1	Installation of Insulation in Buildings	fugitive	Dust release during sawing / cutting of foam	lower value	lower value	1	8.5E-04
8.2	Installation of Insulation in Buildings	fugitive	Dust release during sawing / cutting of foam	upper value	higher value	3	8.5E-04
8.3	Installation of Insulation in Buildings	incineration	Dust release during sawing / cutting of foam	lower value	lower value	1	1.0E-02
8.4	Installation of Insulation in Buildings	incineration	Dust release during sawing / cutting of foam	upper value	higher value	3	1.0E-02
9.1	Generation of foam particles during demolition	fugitive	Dust release during breaking of foam	lower value	lower value	1	7.57E-04
9.2	Generation of foam particles during demolition	fugitive	Dust release during breaking of foam	higher value	lower value	1	0.675
10.1	Recycling of EPS Foam	fugitive	Dust release from grinding of foam	lower value	lower value	1	3.2E-02
10.2	Recycling of EPS Foam	fugitive	Dust release from grinding of foam	lower value	higher value	140	2.3E-04
10.3	Recycling of EPS Foam	fugitive	Dust release from grinding of foam	upper value	lower value	1	1.6E-01
10.4	Recycling of EPS Foam	fugitive	Dust release from grinding of foam	upper value	higher value	140	1.1E-03
10.5	Recycling of EPS Foam	stack	Dust release from grinding of foam	lower value	lower value	1	3.2E-02
10.6	Recycling of EPS Foam	stack	Dust release from grinding of foam	lower value	higher value	140	2.3E-04

Scenario Label	Conditions of Use	Type of Air Release	Characterization of Emission Factor	Emission Factor	Release Days	Number of Release Days	Daily Release (kg/site/day)
10.7	Recycling of EPS Foam	stack	Dust release from grinding of foam	upper value	lower value	1	1.6E-01
10.8	Recycling of EPS Foam	stack	Dust release from grinding of foam	upper value	higher value	140	1.1E-03
10.9	Recycling of EPS Foam	incineration	Dust release from grinding of foam	lower value	lower value	1	6.7E-01
10.10	Recycling of EPS Foam	incineration	Dust release from grinding of foam	lower value	higher value	140	4.8E-03
10.11	Recycling of EPS Foam	incineration	Dust release from grinding of foam	upper value	lower value	1	7.9E-01
10.12	Recycling of EPS Foam	incineration	Dust release from grinding of foam	upper value	higher value	140	5.7E-03
11.1	Formulation of solder	fugitive	TRI data	empirical value	lower value	5	9.1E-02
11.2	Formulation of solder	fugitive	TRI data	empirical value	higher value	300	1.5E-03
11.3	Formulation of solder	stack	TRI data	empirical value	lower value	5	1.3E+00
11.4	Formulation of solder	stack	TRI data	empirical value	higher value	300	2.1E-02
12.1	Use of Solder	incineration	Disposal of transport containers and overapplied/unused solder-incineration	higher value	lower value	4	2.2E-01
12.2	Use of Solder	incineration	Disposal of transport containers and overapplied/unused solder-incineration	higher value	higher value	300	3.0E-03
12.3	Use of Solder	incineration	Disposal of transport containers and overapplied/unused solder-incineration	lower value	lower value	4	2.0E-01
12.4	Use of Solder	incineration	Disposal of transport containers and overapplied/unused solder-incineration	lower value	higher value	300	2.7E-03

F.2 E-FAST and VVWM-PSC Modeling

EPA's Exposure and Fate Assessment Screening Tool (E-FAST), Version 2.0, was specifically developed to support EPA assessments of potential environmental exposures. The E-FAST model contains default parameter values that allow for exposure estimations of a chemical in the surface water after a source emits the chemical into a water body considering simple dilution under four stream flow conditions (harmonic mean, 30Q5, 7Q10, and 1Q10 flow). Details of E-FAST are given in the model user guide at <https://www.epa.gov/tsca-screening-tools/e-fast-exposure-and-fate-assessment-screening-tool-2014-documentation-manual>.

The Point Source Calculator (PSC) is variation of the Variable Volume Water Model (VVWM) used by the USEPA for chemical exposure in surface waters. Details of the VVWM are given in the model user

guide at <https://www.epa.gov/tsca-screening-tools/point-source-calculator-version-105-psc-v105>. The PSC is similar to the SWCC and PFAM in that employs a user-friendly interface that generates a VVWM input file, runs the VVWM, and processes the data. The differences in PSC, SWCC, and PFAM are essentially in the user interface and in the post processing output. In the case of the PSC, the user interface and post processing are intended to assess chemicals that flow directly into a water body and to compare the chemical concentrations to levels of concern.

The conceptualization of the processes in the PSC is given by Figure_Apx F-1. In this conceptualization, the VVWM is used to represent a segment of a water body which receives a direct application of a chemical. The chemical immediately mixes with the water column of the segment. The water column is coupled to a sediment layer and chemical can move into the sediment by a first-order mass transfer process. The chemical can degrade in the water column by user-supplied inputs of hydrolysis, photolysis, and general degradation. Water column chemical can also volatilize according to chemical properties supplied by the user. In the benthic region, the chemical can degrade by hydrolysis and a general benthic degradation rate as supplied by the user. Partitioning to suspended sediment as well as benthic solids occurs according to input values for either an organic carbon partitioning linear coefficient (K_{oc}) or a linear sorption coefficient (K_d). In all cases, the waterbody is modeled as a single segment (comprised of a water column and a benthic region), with the appropriate segment being the one that receives the direct application of the chemical.

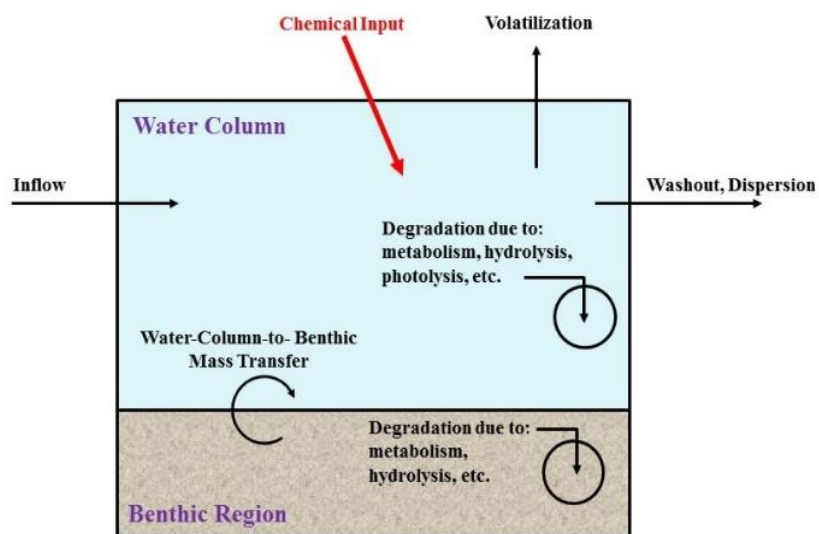

Figure_Apx F-1. Depiction of the Chemical Processes in the Point Source Calculator

Table_Apx F-3. Estimated HBCD Surface Water ($\mu\text{g/L}$) Concentrations Using E-FAST

Scenario Label	Harmonic Mean SWC 50th Percentile	Harmonic Mean SWC 10th Percentile	7Q10 SWC 50th percentile	7Q10 SWC 10th percentile
W1.1	1.2E-01	3.5E+00	3.9E-01	1.9E+01
W1.2	1.1E-02	3.4E-01	3.7E-02	1.9E+00
W1.3	5.9E-01	1.8E+01	1.9E+00	9.8E+01
W1.4	5.7E-02	1.7E+00	1.9E-01	9.4E+00
W1.5	5.4E-01	3.9E+00	2.0E+00	2.0E+01
W1.6	5.2E-02	3.8E-01	1.9E-01	1.9E+00

Scenario Label	Harmonic Mean SWC 50th Percentile	Harmonic Mean SWC 10th Percentile	7Q10 SWC 50th percentile	7Q10 SWC 10th percentile
W1.7	2.7E+00	2.0E+01	1.0E+01	1.0E+02
W1.8	2.6E-01	1.9E+00	9.7E-01	9.7E+00
W2.1	1.1E-01	3.4E+00	3.7E-01	1.9E+01
W2.2	1.9E-02	5.5E-01	6.1E-02	3.0E+00
W2.3	2.5E-01	7.6E+00	8.4E-01	4.2E+01
W2.4	4.2E-02	1.3E+00	1.4E-01	7.0E+00
W2.5	1.1E-02	3.4E-01	3.7E-02	1.9E+00
W2.6	1.9E-03	5.5E-02	6.1E-03	3.0E-01
W2.7	2.6E-02	7.6E-01	8.4E-02	4.2E+00
W2.8	4.2E-03	1.3E-01	1.4E-02	7.0E-01
W2.9	5.2E-02	3.8E-01	1.9E-01	1.9E+00
W2.10	8.5E-03	6.2E-02	3.1E-02	3.1E-01
W2.11	1.2E-01	8.5E-01	4.3E-01	4.3E+00
W2.12	2.0E-02	1.4E-01	7.2E-02	7.2E-01
W3.1	3.7E-01	1.1E+01	1.2E+00	6.1E+01
W3.2	2.5E-02	7.3E-01	8.0E-02	4.0E+00
W3.3	9.0E-01	2.7E+01	3.0E+00	1.5E+02
W3.4	6.1E-02	1.8E+00	2.0E-01	1.0E+01
W3.5	3.7E-02	1.1E+00	1.2E-01	6.1E+00
W3.6	2.5E-03	7.0E-02	1.0E-02	4.0E-01
W3.7	9.0E-02	2.7E+00	3.0E-01	1.5E+01
W3.8	6.1E-03	1.8E-01	2.0E-02	1.0E+00
W3.9	1.7E-01	1.2E+00	6.2E-01	6.3E+00
W3.10	1.1E-02	8.2E-02	4.1E-02	4.2E-01
W3.11	4.1E-01	3.0E+00	1.5E+00	1.5E+01
W3.12	2.8E-02	2.0E-01	1.0E-01	1.0E+00
W4.1	3.5E-01	1.0E+01	1.2E+00	5.8E+01
W4.2	3.0E-02	8.8E-01	9.7E-02	4.9E+00
W4.3	3.5E-02	1.0E+00	1.2E-01	5.8E+00
W4.4	3.0E-03	8.8E-02	9.7E-03	4.9E-01
W4.5	1.6E-01	1.2E+00	5.9E-01	6.0E+00
W4.6	1.4E-02	9.9E-02	5.0E-02	5.0E-01
W5.1	2.4E+01	7.0E+02	7.7E+01	3.9E+03
W5.2	2.4E+00	7.0E+01	7.7E+00	3.9E+02
W5.3	1.1E+01	7.9E+01	4.0E+01	4.0E+02
W5.4	2.7E+00	8.0E+01	8.8E+00	4.4E+02
W5.5	2.7E-01	8.0E+00	8.8E-01	4.4E+01
W5.6	1.2E+00	9.0E+00	4.6E+00	4.6E+01
W5.7	3.2E+01	9.5E+02	1.1E+02	5.3E+03
W5.8	3.2E+00	9.5E+01	1.1E+01	5.3E+02

Scenario Label	Harmonic Mean SWC 50th Percentile	Harmonic Mean SWC 10th Percentile	7Q10 SWC 50th percentile	7Q10 SWC 10th percentile
W5.9	1.5E+01	1.1E+02	5.4E+01	5.5E+02
W5.1	3.7E+00	1.1E+02	1.2E+01	6.1E+02
W5.11	3.7E-01	1.1E+01	1.2E+00	6.1E+01
W5.12	1.7E+00	1.2E+01	6.2E+00	6.3E+01
W6.1	1.1E-01	3.2E+00	3.5E-01	1.8E+01
W6.2	1.1E-02	3.2E-01	3.5E-02	1.8E+00
W6.3	5.0E-02	3.6E-01	1.8E-01	1.8E+00
W6.4	5.8E-03	1.7E-01	1.9E-02	9.5E-01
W6.5	5.8E-04	1.7E-02	1.9E-03	9.5E-02
W6.6	2.7E-03	1.9E-02	9.8E-03	9.9E-02
W6.7	4.8E-01	1.4E+01	1.6E+00	8.0E+01
W6.8	4.8E-02	1.4E+00	1.6E-01	8.0E+00
W6.9	2.2E-01	1.6E+00	8.2E-01	8.3E+00
W6.10	2.6E-02	7.6E-01	8.4E-02	4.2E+00
W6.11	2.6E-03	7.6E-02	8.4E-03	4.2E-01
W6.12	1.2E-02	8.6E-02	4.4E-02	4.4E-01
W8.1	6.8E-03	7.7E-02	3.2E-02	8.0E-01
W8.2	6.8E-04	7.7E-03	3.2E-03	8.0E-02
W8.3	8.0E-01	9.0E+00	3.7E+00	9.4E+01
W8.4	8.0E-02	9.0E-01	3.7E-01	9.4E+00
W9.1	6.0E-03	6.8E-02	2.8E-02	7.1E-01
W9.2	6.0E-04	6.8E-03	2.8E-03	7.1E-02
W9.3	5.4E+00	6.1E+01	2.5E+01	6.4E+02
W9.4	5.4E-01	6.1E+00	2.5E+00	6.4E+01
W10.1	5.0E-01	1.5E+01	1.7E+00	8.3E+01
W10.2	5.0E-02	1.5E+00	1.7E-01	8.3E+00
W10.3	2.3E-01	1.7E+00	8.5E-01	8.6E+00
W10.4	3.6E-03	1.1E-01	1.2E-02	5.9E-01
W10.5	3.6E-04	1.1E-02	1.2E-03	5.9E-02
W10.6	1.7E-03	1.2E-02	6.1E-03	6.2E-02
W10.7	6.0E-01	1.8E+01	2.0E+00	9.9E+01
W10.8	6.0E-02	1.8E+00	2.0E-01	9.9E+00
W10.9	2.8E-01	2.0E+00	1.0E+00	1.0E+01
W10.10	4.3E-03	1.3E-01	1.4E-02	7.1E-01
W10.11	4.3E-04	1.3E-02	1.4E-03	7.1E-02
W10.12	2.0E-03	1.4E-02	7.3E-03	7.3E-02
W12.1	1.9E-03	5.5E-02	6.2E-03	3.1E-01
W12.2	8.7E-03	6.3E-02	3.2E-02	3.2E-01
W12.3	2.5E-05	7.5E-04	8.3E-05	4.2E-03
W12.4	1.2E-04	8.4E-04	4.3E-04	4.3E-03

Scenario Label	Harmonic Mean SWC 50th Percentile	Harmonic Mean SWC 10th Percentile	7Q10 SWC 50th percentile	7Q10 SWC 10th percentile
12.5	3.8E-03	1.1E-01	1.2E-02	6.2E-01
12.6	1.7E-02	1.3E-01	6.4E-02	6.4E-01
12.7	5.0E-05	1.5E-03	1.7E-04	8.3E-03
12.8	2.3E-04	1.7E-03	8.5E-04	8.6E-03

F.3 IIOAC Modeling

The IIOAC modeling methodology is discussed in further detail in Appendix G. The tables below present a summary of the modeled air deposition and estimated soil concentrations.

Table_Apx F-4. Total Annual Particle Deposition from Facility Air Releases

Scenario Name	Range of Total Annual Particle Deposition (g/m ²)					
	Fugitive		Stack		Incineration	
	Min	Max	Min	Max	Min	Max
1. Import/Repackaging						
Fenceline	3.58E-06	2.18E-05	1.52E-06	1.13E-05	6.20E-08	5.81E-07
Community	1.23E-07	6.19E-07	1.03E-07	5.17E-07	4.35E-08	2.18E-07
2. Compounding of Polystyrene Resin to Produce XPS Masterbatch						
Fenceline	2.55E-08	3.48E-08	1.29E-08	1.90E-08	n/a	n/a
Community	7.57E-10	9.04E-10	6.32E-10	7.57E-10	n/a	n/a
3. Manufacturing of XPS Foam using XPS Masterbatch						
Fenceline	2.64E-07	3.48E-07	1.38E-07	2.03E-07	n/a	n/a
Community	7.15E-09	7.16E-09	5.98E-09	5.98E-09	n/a	n/a
4. Manufacturing of XPS Foam using HBCD Powder						
Fenceline	3.32E-08	4.38E-08	1.73E-08	1.27E-06	5.85E-08	1.02E-07
Community	9.00E-10	9.01E-10	7.53E-10	6.46E-08	3.58E-08	5.70E-08
5. Manufacturing of EPS Foam from Imported EPS Resin Beads						
Fenceline	3.83E-06	2.28E-05	1.89E-06	1.19E-05	1.63E-06	5.48E-06
Community	1.23E-07	6.18E-07	1.03E-07	5.19E-07	9.18E-07	1.75E-06
6. Manufacturing of SIPs and Automobile Replacement Parts						
Fenceline	1.81E-07	1.02E-06	7.69E-08	5.35E-07	6.23E-07	3.45E-06
Community	6.20E-09	2.78E-08	5.22E-09	2.33E-08	4.37E-07	1.10E-06
8. Installation of XPS/EPS Foam Insulation in Residential, Public, and Commercial Buildings, and Other Structures						
Fenceline	1.13E-10	3.48E-08	n/a	n/a	7.72E-10	1.65E-07
Community	2.32E-12	8.17E-10	n/a	n/a	1.62E-10	3.21E-08
9. Demolition of XPS/EPS Foam Insulation in Residential, Public and Commercial Buildings, and Other Structures						
Fenceline	1.00E-10	8.95E-08	n/a	n/a	n/a	n/a
Community	2.06E-12	1.84E-09	n/a	n/a	n/a	n/a
10. Recycling of EPS Foam						
Fenceline	2.68E-09	2.11E-08	1.33E-09	1.22E-08	1.14E-09	3.64E-09
Community	8.64E-11	4.32E-10	7.23E-11	3.63E-10	6.42E-10	7.65E-10
11. Formulation of Solder						

Scenario Name	Range of Total Annual Particle Deposition (g/m ²)					
	Fugitive		Stack		Incineration	
	Min	Max	Min	Max	Min	Max
Fenceline	7.25E-08	8.48E-08	8.12E-07	1.17E-06	n/a	n/a
Community	2.81E-09	2.81E-09	4.22E-08	4.23E-08	n/a	n/a
12. Use of Solder						
Fenceline	n/a	n/a	n/a	n/a	1.09E-09	4.03E-09
Community	n/a	n/a	n/a	n/a	7.66E-10	8.66E-10

Table_Apx F-5. Estimated Soil Concentrations from Facility Air Releases

Scenario Name	Range of Estimate Soil Concentration (µg/kg)					
	Fugitive		Stack		Incineration	
	Min	Max	Min	Max	Min	Max
1. Import/Repackaging						
Fenceline	2.11E-02	1.28E-01	8.95E-03	6.66E-02	3.64E-04	3.42E-03
Community	7.22E-04	3.64E-03	6.08E-04	3.04E-03	2.56E-04	1.29E-03
2. Compounding of Polystyrene Resin to Produce XPS Masterbatch						
Fenceline	1.50E-04	2.05E-04	7.56E-05	1.12E-04	n/a	n/a
Community	4.45E-06	5.32E-06	3.72E-06	4.45E-06	n/a	n/a
3. Manufacturing of XPS Foam using XPS Masterbatch						
Fenceline	1.55E-03	2.05E-03	8.10E-04	1.19E-03	n/a	n/a
Community	4.20E-05	4.21E-05	3.52E-05	3.52E-05	n/a	n/a
4. Manufacturing of XPS Foam using HBCD Powder						
Fenceline	1.95E-04	2.58E-04	1.02E-04	7.46E-03	3.44E-04	5.98E-04
Community	5.29E-06	5.30E-06	4.43E-06	3.80E-04	2.11E-04	3.35E-04
5. Manufacturing of EPS Foam from Imported EPS Resin Beads						
Fenceline	2.25E-02	1.34E-01	1.11E-02	7.00E-02	9.59E-03	3.22E-02
Community	7.26E-04	3.64E-03	6.08E-04	3.05E-03	5.40E-03	1.03E-02
6. Manufacturing of SIPs and Automobile Replacement Parts						
Fenceline	1.07E-03	6.03E-03	4.53E-04	3.15E-03	3.66E-03	2.03E-02
Community	3.65E-05	1.64E-04	3.07E-05	1.37E-04	2.57E-03	6.48E-03
8. Installation of XPS/EPS Foam Insulation in Residential, Public, and Commercial Buildings, and Other Structures						
Fenceline	6.64E-07	2.05E-04	n/a	n/a	4.54E-06	9.68E-04
Community	1.36E-08	4.81E-06	n/a	n/a	9.53E-07	1.89E-04
9. Demolition of XPS/EPS Foam Insulation in Residential, Public and Commercial Buildings, and Other Structures						
Fenceline	5.91E-07	5.27E-04	n/a	n/a	n/a	n/a
Community	1.21E-08	1.08E-05	n/a	n/a	n/a	n/a
10. Recycling of EPS Foam						
Fenceline	1.58E-05	1.24E-04	7.80E-06	7.20E-05	6.72E-06	2.14E-05
Community	5.08E-07	2.54E-06	4.25E-07	2.14E-06	3.78E-06	4.50E-06
11. Formulation of Solder						
Fenceline	4.27E-04	4.99E-04	4.77E-03	6.88E-03	n/a	n/a
Community	1.65E-05	1.65E-05	2.48E-04	2.49E-04	n/a	n/a

Scenario Name	Range of Estimate Soil Concentration ($\mu\text{g}/\text{kg}$)								
	Fugitive			Stack			Incineration		
	Min	-	Max	Min	-	Max	Min	-	Max
12. Use of Solder									
Fenceline	n/a	-	n/a	n/a	-	n/a	6.42E-06	-	2.37E-05
Community	n/a	-	n/a	n/a	-	n/a	4.51E-06	-	5.09E-06

Appendix G GENERAL POPULATION, HIGHLY EXPOSED AND CONSUMER EXPOSURES

G.1 Exposure Factors for General Population, Highly Exposed, and Consumer Exposure Calculations

Exposure factors in this section were applied to all general population, highly exposed, and consumer scenarios, as applicable.

Table_Apx G-1. Body Weight by Age Group.

Age group	Mean body weight (kg) ¹
Infant (<1 year)*	7.83
Young Toddler (1-<2 years)	11.4
Toddler (2-<3 years)	13.8
Small Child (3-<6 years)	18.6
Child (6-<11 years)	31.8
Teen (11-<16 years)	56.8
Adults (16-<70 years) ¹	80.0 ²

* Age group weighted average

¹ U.S. EPA. Exposure Factors Handbook ([U.S. EPA 2011b](#)), Table 8-3.

² U.S. EPA. Exposure Factors Handbook ([U.S. EPA 2011b](#)), Table 8-1.

Table_Apx G-2. Central Tendency (Mean) Dietary Ingestion Rates by Age Group- Fruit, Vegetables, Grains, Meats, Dairy, Fats, Consumers Only.

Age group	Mean Ingestion Rates (g/kg-day) Consumers Only					
	Fruits ¹	Vegetables ¹	Grains ²	Meat ³	Dairy ³	Fats ³
Infant (<1 year)	9.90	6.70	3.90	3.00	13.10	4.6*
Young Toddler (1-<2 years)	9.80	6.70	6.40	4.10	48.80	4.00
Toddler (2-<3 years)	7.70	6.00	6.40	4.30	36.10	3.60
Small Child (3-<6 years)	5.80	5.30	6.00	4.00	22.60	3.40
Child (6-<11 years)	3.20	3.80	4.60	3.00	13.80	2.60
Teen (11-<16 years)	1.60	2.40	2.70	2.20	6.80	1.60
Adults (16-<70 years)*	1.4	2.5	2.0	1.7	3.3	1.05
Subsistence Fisher (adult)	1.4	2.5	2.0	0	3.3	1.05

* Age group weighted average

¹ U.S. EPA. Exposure Factors Handbook ([U.S. EPA 2011b](#)), Table 9-1.

² U.S. EPA. Exposure Factors Handbook ([U.S. EPA 2011b](#)), Table 12-1.

³ U.S. EPA. Exposure Factors Handbook ([U.S. EPA 2011b](#)), Table 11-1.

Table_Apx G-3. High-end (95th Percentile) Dietary Ingestion Rates (Consumers Only) by Age Group- Fruit, Vegetables, Grains, Meats, Dairy, Fats

Age Group	95 th Percentile Ingestion Rates (g/kg-day) Consumers Only					
	Fruits ¹	Vegetables ¹	Grains ²	Meat ³	Dairy ³	Fats ³
Infant (<1 year)	27.2	18.70	8.70	8.90	64.2	8.91*
Young Toddler (1-<2 years)	24.00	16.30	12.70	9.60	100.5	7.10
Toddler (2-<3 years)	20.50	14.00	11.70	9.60	78.7	6.40
Small Child (3-<6 years)	16.40	13.30	10.50	9.00	51.1	5.8
Child (6-<11 years)	10.00	9.90	8.70	6.70	31.8	4.2
Teen (11-<16 years)	5.20	6.30	5.70	4.90	18.2	3.0
Adults (16-<70 years)*	4.3	6.0	4.3	3.8	9.9	2.01
Subsistence Fisher (adult)	4.3	6.0	4.3	0	9.9	2.01

* Age group weighted average

¹ U.S. EPA. Exposure Factors Handbook ([U.S. EPA 2011b](#)), Table 9-1.

² U.S. EPA. Exposure Factors Handbook ([U.S. EPA 2011b](#)), Table 12-1.

³ U.S. EPA. Exposure Factors Handbook ([U.S. EPA 2011b](#)), Table 11-1.

Table_Apx G-4. Fish Ingestion Rates by Age Group

Age group	Fish ingestion rate (g/kg-day)*	
	50th percentile	90th percentile
Infant (<1 year) ¹	n/a	n/a
Young Toddler (1-<2 years) ¹	0.053	0.412
Toddler (2-<3 years) ¹	0.043	0.341
Small Child (3-<6 years) ¹	0.038	0.312
Child (6-<11 years) ¹	0.035	0.242
Teen (11-<16 years) ²	0.019	0.146
Adult (16-<70 years) ²	0.063	0.277
Subsistence Fisher (adult) ³	1.78	

* Age group weighted average, using body weight from Table_Apx G-1.

¹ U.S. EPA. Exposure Factors Handbook ([U.S. EPA 2011b](#)), Table 20a.

² U.S. EPA. Exposure Factors Handbook ([U.S. EPA 2011b](#)), Table 9a.

³ U.S. EPA. Methodology for deriving ambient water quality criteria for the protection of human health ([U.S. EPA 2000a](#))

Table_Apx G-5. Breastmilk Ingestion Rates

Age group	Breast Milk Ingestion (mL/kg day) ¹		Breast Milk Lipids Ingestion (g/kg day) ²	
	Mean	Upper	Mean	Upper
Birth to <1 month	6	8.7	6.2	9.0
1 to <3 month	5.5	8	5.7	8.2
3 to <6 month	4.2	6.1	4.3	6.3

Age group	Breast Milk Ingestion (mL/kg day) ¹		Breast Milk Lipids Ingestion (g/kg day) ²	
	Mean	Upper	Mean	Upper
6 to <12 month	3.3	5.2	3.4	5.4
Birth to <1 year	4.1	6.2	4.2	6.4

¹ U.S. EPA. Exposure Factors Handbook ([U.S. EPA 2011b](#)), Table 15-1.

² Converted using 1.03 g/mL density of human breastmilk.

Table_Apx G-6. Inhalation Rate by Age Group

Age group	Mean (m ³ /day) ¹	95th (m ³ /day) ¹
Infant (<1 year)	5.4	9.2
Young Toddler (1-<2 years)	8	12.8
Toddler (2-<3 years)	8.9	13.7
Small Child (3-<6 years)	10.1	13.8
Child (6-<11 years)	12	16.6
Teen (11-<16 years)	15.2	21.9
Adults (16-<70 years)*	15.6	21.1

* Age group weighted average

¹ U.S. EPA. Exposure Factors Handbook ([U.S. EPA 2011b](#)), Table 6.1 Long-Term Inhalation Rates.

Table_Apx G-7. Dust and Soil Ingestion Rate by Age Group

Age group	Dust Ingestion Rate (mg/day)		Soil Ingestion Rate (mg/day)	
	Central Tendency	High-end	Central Tendency	High-end
Infant (<1 year)	30	80	25	70
Young Toddler (1-<2 years)	50	100	40	90
Toddler (2-<3 years)	30	100	30	90
Small Child (3-<6 years)	30	100	30	90
Child (6-<11 years)	30	100	30	90
Teen (11-<16 years)	21.7	66.7	13.3	56.7
Adult (16-<70 years)	20	60	10	50

¹ U.S. EPA. Exposure Factors Handbook ([U.S. EPA 2011b](#)), Table 5-1.

Table_Apx G-8. Generic Activity Patterns for Time Spent While Awake

Microenvironment	Time Awake Spent (hr/day) ¹			Fraction Awake Time Spent Unitless)		
	SAH Adult / Child	Part-Time School / COF / Work	Full-Time School / COF / Work	SAH Adult / Child	Part-Time School / COF / Work	Full-Time School / COF / Work
Public and Commercial Buildings	1	3	6	0.08	0.23	0.46
Outside	2	2	2	0.15	0.15	0.15
Automobile	1	2	2	0.08	0.15	0.15
Residences	11	8	5	0.85	0.62	0.38

Microenvironment	Time Awake Spent (hr/day) ¹			Fraction Awake Time Spent Unitless)		
	SAH Adult / Child	Part-Time School/ COF / Work	Full-Time School / COF / Work	SAH Adult / Child	Part-Time School/ COF / Work	Full-Time School / COF / Work
Total	13	13	13			

SAH = Stay at home

COF = Child-occupied facility

¹ CHAD Database ([U.S. EPA 2009b](https://www.epa.gov/chad))**Table_Apx G-9. Generic Activity Patterns for Time Spent in a Day (24 hours)**

Microenvironment	Time Spent Total (hr/day) ¹			Fraction Time Spent Total (unitless)		
	SAH Adult / Child	Part-Time School/ COF / Work	Full-Time School / COF / Work	SAH Adult / Child	Part-Time School/ COF / Work	Full-Time School / COF / Work
Public and Commercial Buildings	1	3	6	0.04	0.13	0.25
Outside	2	2	2	0.08	0.08	0.08
Automobile	1	2	2	0.04	0.08	0.08
Residences	20	17	14	0.83	0.71	0.58
Total	24	24	24			

SAH = Stay at home

COF = Child-occupied facility

¹ CHAD Database ([U.S. EPA 2009b](https://www.epa.gov/chad))**Table_Apx G-10. Surface Area to Body Weight Ratios (cm²/kg) By Age Group^a**

Age Group	Surface Area to Body Weight Ratios (cm ² /kg)	
	Hands, 45% of Legs, 50% of Arms	Hands
Infant (<1 year)	110.6	27.2
Young Toddler (1-<2 years)	104.7	26.3
Toddler (2-<3 years)	102.4	20.3
Small Child (3-<6 years)	95.6	19.9
Child (6-<11 years)	83.8	16.0
Teen (11-<16 years)	70.9	12.7
Adult (16-<70 years)	65.4	12.2

¹ Surface area to body weight ratios were calculated using the mean surface areas and mean body weights from Tables 7-2 and 8-1 of U.S. EPA. Exposure Factors Handbook ([U.S. EPA 2011b](https://www.epa.gov/efh)), respectively.

Table_Apx G-11. Dermal Adherence Factors for Dust By Age Group

Age Group	Dust Adherence Factor By Body Part (mg/cm ²) ¹				Weighting for Exposed Surface Area of Body (Hands, 45% of Legs, 50% of Arms) ²	
	Activity Grouping	Hands	Legs	Arms	Total Surface Area Exposed (cm ²)	Weighted Dust Adherence Factor (mg/cm ²)
Infant (<1 year)	Residential, indoors	0.011	0.0035	0.0041	0.086	0.006
Young Toddler (1-<2 years)					0.119	0.006
Toddler (2-<3 years)					0.141	0.005
Small Child (3-<6 years)					0.178	0.005
Child (6-<11 years)					0.266	0.005
Teen (11-<16 years)	Activities with soil - Adult	0.1595	0.0189	0.0379	0.403	0.049
Adult (16-<70 years)					0.524	0.050

¹ The adherence factors by body part are the recommended mean factors from Table 7-4 of U.S. EPA. Exposure Factors Handbook ([U.S. EPA 2011b](#)) for the activity grouping shown. The activity grouping was selected based on professional judgment.

² The adherence factors by body part were weighted according to the body parts exposed using equation 7-1 in U.S. EPA. Exposure Factors Handbook ([U.S. EPA 2011b](#)). Mean surface areas from Table 7-2 of U.S. EPA. Exposure Factors Handbook ([U.S. EPA 2011b](#)) were used in the calculations.

Table_Apx G-12. Dermal Adherence Factors for Soil By Age Group

Age Group	Soil Adherence Factor By Body Part (mg/cm ²) ¹				Weighting for Exposed Surface Area of Body (Hands, 45% of Legs, 50% of Arms) ²	
	Activity Grouping	Hands	Legs	Arms	Total Surface Area Exposed (cm ²)	Weighted Dust Adherence Factor (mg/cm ²)
Infant (<1 year)	Activities with soil - Children	0.17	0.051	0.046	0.086	0.079
Young Toddler (1-<2 years)					0.119	0.079
Toddler (2-<3 years)					0.141	0.073
Small Child (3-<6 years)					0.178	0.074
Child (6-<11 years)					0.266	0.072
Teen (11-<16 years)	Activities with soil - Adult	0.1595	0.0189	0.0379	0.403	0.049
Adult (16-<70 years)					0.524	0.050

¹ The adherence factors by body part are the recommended mean factors from Table 7-4 of U.S. EPA. Exposure Factors Handbook ([U.S. EPA 2011b](#)) for the activity grouping shown. The activity grouping was selected based on professional judgment.

² The adherence factors by body part were weighted according to the body parts exposed using equation 7-1 in U.S. EPA. Exposure Factors Handbook ([U.S. EPA 2011b](#)). Mean surface areas from Table 7-2 of U.S. EPA. Exposure Factors Handbook ([U.S. EPA 2011b](#)) were used in the calculations.

Table_Apx G-13. Surface Area of Object Mouthed (cm²)

Age Group	Surface Area of Object Mouthed (cm ²) ¹	
	Central Tendency	High-End
Young Toddler (1-<2 years)	10	50

¹ Series on testing and assessment No. 306. ([OECD 2019](#))

Table_Apx G-14. Hourly Mouthing Duration (min)

Age Group	Hourly Mouthing Duration (min) ¹	
	Central Tendency (Mean)	High-End (95 th Percentile)
Infants (0-1 year)	7.1	13.1
Young Toddler (1-<2 years)	3	9.7

¹ Values are for “Non-Pacifier” objects, ages 3 to 12 months (infants) and ages 12 to 24 months (young toddler) as cited in Table 4-20 of U.S. EPA. Exposure Factors Handbook ([U.S. EPA 2011b](#)) and originating from ([Greene 2002](#)). Non-pacifier objects include all soft plastic items, anatomy, non-soft plastic items, and “other” items.

G.2 Scenario G1: General Population

The tables in this section provide a detailed breakdown of the dietary doses by food group.

Table_Apx G-15. Estimated Average Daily Dose (ADD) by Age Group for Diet

Age Group	Dietary ADR (mg/kg-day)								
	Fruits	Veggies	Grains	Meats	Dairy	Fats	Fish	Breast milk	Total from Diet
Infant (<1 year)	2.6E-07	1.1E-06	3.2E-07	3.4E-07	2.1E-06	8.0E-07	N/A	1.9E-05	2.4E-05
Young Toddler (1-<2 years)	2.6E-07	1.1E-06	5.3E-07	4.6E-07	7.8E-06	7.0E-07	1.1E-07	N/A	1.1E-05
Toddler (2-<3 years)	2.0E-07	9.7E-07	5.3E-07	4.8E-07	5.8E-06	6.3E-07	8.7E-08	N/A	8.7E-06
Small Child (3-<6 years)	1.5E-07	8.5E-07	4.9E-07	4.5E-07	3.6E-06	5.9E-07	7.5E-08	N/A	6.2E-06
Child (6-<11 years)	8.4E-08	6.1E-07	3.8E-07	3.4E-07	2.2E-06	4.5E-07	6.9E-08	N/A	4.1E-06
Teen (11-<16 years)	4.2E-08	3.9E-07	2.2E-07	2.5E-07	1.1E-06	2.8E-07	3.9E-08	N/A	2.3E-06
Adult (16-<70 years)	3.7E-08	4.1E-07	1.6E-07	1.9E-07	5.3E-07	1.8E-07	1.3E-07	N/A	1.6E-06
Subsistence Fisher (NF)	3.7E-08	4.1E-07	1.6E-07	0.0E+00	5.3E-07	1.8E-07	7.4E-04	N/A	7.4E-04
Subsistence Fisher (FF I)	3.7E-08	4.1E-07	1.6E-07	0.0E+00	5.3E-07	1.8E-07	4.1E-05	N/A	4.2E-05
Subsistence Fisher (FF II)	3.7E-08	4.1E-07	1.6E-07	0.0E+00	5.3E-07	1.8E-07	1.1E-05	N/A	1.2E-05

Table_Apx G-16. Percent of Dietary ADD by Food Group

Age Group	Percent of Dietary ADD (mg/kg-day)								
	Fruits	Veggies	Grains	Meats	Dairy	Fats	Fish	Breast milk	Total from Diet
Infant (<1 year)	1.1%	4.5%	1.4%	1.4%	8.8%	3.4%	0.0%	79.4%	100%
Young Toddler (1-<2 years)	2.4%	9.9%	4.8%	4.2%	71.4%	6.4%	1.0%	0.0%	100%
Toddler (2-<3 years)	2.3%	11.1%	6.1%	5.6%	66.6%	7.2%	1.0%	0.0%	100%
Small Child (3-<6 years)	2.5%	13.7%	7.9%	7.2%	58.0%	9.5%	1.2%	0.0%	100%
Child (6-<11 years)	2.0%	14.8%	9.1%	8.2%	53.3%	10.9%	1.7%	0.0%	100%
Teen (11-<16 years)	1.8%	16.8%	9.6%	10.8%	47.2%	12.1%	1.7%	0.0%	100%
Adult (16-<70 years)	2.3%	24.8%	9.9%	11.8%	32.4%	11.2%	7.7%	0.0%	100%
Subsistence Fisher (NF)	0.005%	0.1%	0.022%	0.0%	0.1%	0.02%	99.8%	0.0%	100.0%
Subsistence Fisher (FF I)	0.1%	1.0%	0.4%	0.0%	1.3%	0.4%	96.9%	0.0%	100.0%
Subsistence Fisher (FF II)	0.3%	3.4%	1.4%	0.0%	4.5%	1.5%	88.9%	0.0%	100.0%

Table_Apx G-17. Estimated Average Dose Rate (ADR) by Age Group for Diet

Age Group	Dietary ADR (mg/kg-day)								
	Fruits	Veggies	Grains	Meats	Dairy	Fats	Fish	Breast milk	Total from Diet
Infant (<1 year)	1.5E-06	3.5E-06	9.7E-07	1.6E-06	1.6E-05	2.0E-06	N/A	5.6E-05	8.1E-05
Young Toddler (1-<2 years)	1.3E-06	3.0E-06	1.4E-06	1.7E-06	2.4E-05	1.6E-06	1.7E-06	N/A	3.5E-05
Toddler (2-<3 years)	1.1E-06	2.6E-06	1.3E-06	1.7E-06	1.9E-05	1.5E-06	1.4E-06	N/A	2.9E-05
Small Child (3-<6 years)	9.0E-07	2.5E-06	1.2E-06	1.6E-06	1.2E-05	1.3E-06	1.3E-06	N/A	2.1E-05
Child (6-<11 years)	5.5E-07	1.8E-06	9.7E-07	1.2E-06	7.7E-06	9.7E-07	9.9E-07	N/A	1.4E-05
Teen (11-<16 years)	2.8E-07	1.2E-06	6.3E-07	8.7E-07	4.4E-06	6.9E-07	6.0E-07	N/A	8.7E-06
Adult (16-<70 years)	2.4E-07	1.1E-06	4.7E-07	6.8E-07	2.4E-06	4.6E-07	1.1E-06	N/A	6.5E-06
Subsistence Fisher (NF)	2.4E-07	1.1E-06	4.7E-07	0.0E+00	2.4E-06	4.6E-07	7.4E-04	N/A	7.5E-04
Subsistence Fisher (FF I)	2.4E-07	1.1E-06	4.7E-07	0.0E+00	2.4E-06	4.6E-07	4.1E-05	N/A	4.5E-05
Subsistence Fisher (FF II)	2.4E-07	1.1E-06	4.7E-07	0.0E+00	2.4E-06	4.6E-07	1.1E-05	N/A	1.5E-05

Table_Apx G-18. Percent of Dietary ADR by Food Group

Age Group	Percent of Dietary ADR								
	Fruits	Veggies	Grains	Meats	Dairy	Fats	Fish	Breast milk	Total from Diet
Infant (<1 year)	1.8%	4.3%	1.2%	2.0%	19.3%	2.5%	0.0%	68.9%	100.0%
Young Toddler (1-<2 years)	3.7%	8.6%	4.0%	4.9%	69.3%	4.6%	4.8%	0.0%	100.0%
Toddler (2-<3 years)	3.9%	9.1%	4.5%	6.0%	66.5%	5.1%	4.9%	0.0%	100.0%
Small Child (3-<6 years)	4.2%	11.7%	5.5%	7.6%	58.6%	6.3%	6.0%	0.0%	100.0%
Child (6-<11 years)	3.8%	12.9%	6.8%	8.4%	54.2%	6.8%	7.0%	0.0%	100.0%
Teen (11-<16 years)	3.3%	13.5%	7.3%	10.1%	50.9%	8.0%	6.9%	0.0%	100.0%
Adult (16-<70 years)	3.7%	17.1%	7.3%	10.4%	36.9%	7.1%	17.5%	0.0%	100.0%
Subsistence Fisher (NF)	0.03%	0.1%	0.1%	0.0%	0.3%	0.1%	99.4%	0.0%	100.0%
Subsistence Fisher (FF I)	0.5%	2.5%	1.0%	0.0%	5.3%	1.0%	89.7%	0.0%	100.0%
Subsistence Fisher (FF II)	1.6%	7.3%	3.1%	0.0%	15.7%	3.0%	69.3%	0.0%	100.0%

G.3 Scenario H1: Near Facility Dietary (Fish) — Ingestion

Table_Apx G-19. Surface Water Concentrations from VVWM-PSC Modeling and Calculated Fish Tissue Concentrations

Scenario Label	Water Column Concentration (µg/L) - 21 day average - Dissolved		Fish Tissue Concentration (mg/kg) ¹	
	Harmonic Mean Flow (50 th percentile)	Harmonic Mean Flow (10 th percentile)	Harmonic Mean Flow (50 th percentile)	Harmonic Mean Flow (10 th percentile)
W1.1	8.5E-03	2.5E-01	3.9E-01	1.2E+01
W1.2	6.9E-03	2.1E-01	3.2E-01	9.5E+00
W1.3	4.3E-02	1.2E+00	2.0E+00	5.8E+01
W1.4	3.5E-02	1.0E+00	1.6E+00	4.6E+01
W1.5	3.9E-02	2.8E-01	1.8E+00	1.3E+01
W1.6	3.2E-02	2.3E-01	1.5E+00	1.1E+01
W1.7	2.0E-01	1.4E+00	9.1E+00	6.5E+01
W1.8	1.6E-01	1.2E+00	7.5E+00	5.4E+01
W2.1	4.1E-03	1.2E-01	1.9E-01	5.5E+00
W2.2	2.7E-03	7.8E-02	1.2E-01	3.6E+00
W2.3	9.2E-03	2.7E-01	4.3E-01	1.2E+01
W2.4	6.1E-03	1.8E-01	2.8E-01	8.3E+00
W2.5	4.1E-04	1.2E-02	1.9E-02	5.5E-01
*W2.6				
W2.7	9.2E-04	2.7E-02	4.3E-02	1.2E+00

Scenario Label	Water Column Concentration ($\mu\text{g/L}$) - 21 day average - Dissolved		Fish Tissue Concentration (mg/kg) ¹	
	Harmonic Mean Flow (50 th percentile)	Harmonic Mean Flow (10 th percentile)	Harmonic Mean Flow (50 th percentile)	Harmonic Mean Flow (10 th percentile)
*W2.8				
W2.9	1.9E-03	1.3E-02	8.7E-02	6.2E-01
*W2.10				
W2.11	4.2E-03	3.0E-02	2.0E-01	1.4E+00
*W2.12				
W3.1	1.3E-02	3.8E-01	6.2E-01	1.7E+01
W3.2	8.9E-04	2.6E-02	4.1E-02	1.2E+00
W3.3	3.2E-02	9.2E-01	1.5E+00	4.3E+01
W3.4	2.2E-03	6.4E-02	1.0E-01	3.0E+00
W3.5	1.3E-03	3.8E-02	6.2E-02	1.7E+00
W3.6	8.9E-05	2.6E-03	4.1E-03	1.2E-01
W3.7	3.2E-03	9.2E-02	1.5E-01	4.3E+00
W3.8	2.2E-04	6.4E-03	1.0E-02	3.0E-01
W3.9	6.0E-03	4.2E-02	2.8E-01	2.0E+00
W3.10	4.0E-04	2.9E-03	1.9E-02	1.4E-01
W3.11	1.5E-02	1.0E-01	6.9E-01	4.8E+00
W3.12	1.0E-03	7.2E-03	4.6E-02	3.3E-01
W4.1	1.3E-02	3.6E-01	5.9E-01	1.7E+01
W4.2	1.1E-03	3.1E-02	4.9E-02	1.4E+00
W4.3	1.3E-03	3.6E-02	5.9E-02	1.7E+00
W4.4	1.1E-04	3.1E-03	4.9E-03	1.4E-01
W4.5	5.8E-03	4.0E-02	2.7E-01	1.9E+00
W4.6	4.9E-04	3.5E-03	2.3E-02	1.6E-01
W5.1	8.5E-01	2.5E+01	3.9E+01	1.2E+03
W5.2	8.5E-02	2.5E+00	3.9E+00	1.2E+02
W5.3	3.9E-01	2.8E+00	1.8E+01	1.3E+02
W5.4	6.8E-01	2.0E+01	3.2E+01	9.3E+02
W5.5	6.8E-02	2.0E+00	3.2E+00	9.3E+01
W5.6	3.1E-01	2.2E+00	1.4E+01	1.0E+02
W5.7	1.2E+00	3.4E+01	5.4E+01	1.6E+03
W5.8	1.2E-01	3.4E+00	5.4E+00	1.6E+02
W5.9	5.3E-01	3.8E+00	2.5E+01	1.8E+02
W5.10	9.3E-01	2.7E+01	4.3E+01	1.3E+03
W5.11	9.3E-02	2.7E+00	4.3E+00	1.3E+02
W5.12	4.3E-01	3.1E+00	2.0E+01	1.4E+02
W6.1	3.9E-03	1.1E-01	1.8E-01	5.3E+00
W6.2	3.9E-04	1.1E-02	1.8E-02	5.3E-01
W6.3	1.8E-03	1.3E-02	8.3E-02	5.9E-01
W6.4	3.7E-03	1.1E-01	1.7E-01	5.1E+00

Scenario Label	Water Column Concentration ($\mu\text{g/L}$) - 21 day average - Dissolved		Fish Tissue Concentration (mg/kg) ¹	
	Harmonic Mean Flow (50 th percentile)	Harmonic Mean Flow (10 th percentile)	Harmonic Mean Flow (50 th percentile)	Harmonic Mean Flow (10 th percentile)
*W6.5				
*W6.6				
W6.7	1.7E-02	5.1E-01	8.1E-01	2.4E+01
W6.8	1.7E-03	5.1E-02	8.1E-02	2.4E+00
W6.9	7.9E-03	5.7E-02	3.7E-01	2.7E+00
W6.10	1.7E-02	4.9E-01	7.7E-01	2.3E+01
W6.11	1.7E-03	4.9E-02	7.7E-02	2.3E+00
W6.12	7.6E-03	5.5E-02	3.6E-01	2.6E+00
W8.1	2.4E-05	2.3E-04	1.1E-03	1.1E-02
*W8.2				
W8.3	2.8E-02	2.8E-01	1.3E-00	1.3E+01
W8.4	2.8E-03	2.8E-02	1.32E+01	1.29E+00
*W9.1				
*W9.2				
W9.3	1.91E-01	1.9E+00	8.9E+00	8.6E+01
W9.4	1.91E-02	1.9E-01	8.9E-01	8.6E+00
W10.1	1.8E-02	5.2E-01	8.4E-01	2.4E+01
W10.2	1.8E-03	5.2E-02	8.4E-02	2.4E+00
W10.3	8.3E-03	5.8E-02	3.8E-01	2.7E+00
W10.4	9.1E-04	2.7E-02	4.2E-02	1.2E+00
*W10.5				
*W10.6				
W10.7	2.2E-02	6.2E-01	1.0E+00	2.9E+01
W10.8	2.2E-03	6.2E-02	1.0E-01	2.9E+00
W10.9	9.8E-03	6.9E-02	4.6E-01	3.2E+00
W10.10	1.1E-03	3.2E-02	5.0E-02	1.5E+00
*W10.11				
*W10.12				
W12.1	6.8E-05	1.9E-03	3.2E-03	9.0E-02
W12.2	3.1E-04	2.2E-03	1.4E-02	1.0E-01
*W12.3				
*W12.4				
W12.5	1.4E-04	3.9E-03	6.3E-03	1.8E-01
W12.6	6.2E-04	4.4E-03	2.9E-02	2.0E-01
W12.7				
W12.8				

* Scenario was not run in the second tier model (VWWM-PSC) because risks were not of concern using the first tier model (E-FAST).

¹ Fish Tissue Concentration (mg/kg) = Surface Water Concentration ($\mu\text{g/L}$) * Wet Weight BAF (46,488 L/kg) * Conversion Factor (0.001 $\text{mg}/\mu\text{g}$)

Table_Apx G-20. Highly Exposed Acute Dose Rate and Average Daily Doses (mg/kg/day) for Modeled Fish Ingestion Only

Scenario Label	Young Toddler Doses (mg/kg/day)		Toddler Doses (mg/kg/day)		Small Child Doses (mg/kg/day)		Child Doses (mg/kg/day)		Teenager Doses (mg/kg/day)		Adult Doses (mg/kg/day)		
	ADR	ADD	ADR	ADD	ADR	ADD	ADR	ADD	ADR	ADD	ADR	ADD - CT	ADD -HE
W1.1	4.76E-03	2.1E-05	3.9E-03	1.7E-05	3.6E-03	1.5E-05	2.8E-03	1.4E-05	1.7E-03	7.6E-06	3.2E-03	5.5E-06	1.5E-05
W1.2	3.9E-03	1.7E-05	3.2E-03	1.4E-05	3.0E-03	1.2E-05	2.3E-03	1.1E-05	1.4E-03	6.3E-06	2.6E-03	4.5E-06	1.2E-05
W1.3	2.4E-02	1.0E-04	2.0E-02	8.6E-05	1.8E-02	7.5E-05	1.4E-02	6.9E-05	8.5E-03	3.8E-05	1.6E-02	2.8E-05	7.6E-05
W1.4	1.9E-02	8.6E-05	1.6E-02	7.1E-05	1.4E-02	6.1E-05	1.1E-02	5.6E-05	6.8E-03	3.2E-05	1.3E-02	2.3E-05	6.3E-05
W1.5	5.4E-03	9.5E-05	4.4E-03	7.9E-05	4.0E-03	6.8E-05	3.1E-03	6.3E-05	1.9E-03	3.5E-05	3.6E-03	2.5E-05	7.0E-05
W1.6	4.4E-03	7.8E-05	3.6E-03	6.4E-05	3.3E-03	5.6E-05	2.6E-03	5.1E-05	1.6E-03	2.9E-05	3.0E-03	2.1E-05	5.7E-05
W1.7	2.7E-02	4.8E-04	2.2E-02	3.9E-04	2.0E-02	3.4E-04	1.6E-02	3.1E-04	9.5E-03	1.8E-04	1.8E-02	1.3E-04	3.5E-04
W1.8	2.2E-02	3.9E-04	1.8E-02	3.2E-04	1.7E-02	2.8E-04	1.3E-02	2.6E-04	7.9E-03	1.4E-04	1.5E-02	1.0E-04	2.9E-04
W2.1	2.3E-03	1.0E-05	1.9E-03	8.3E-06	1.7E-03	7.2E-06	1.3E-03	6.6E-06	8.0E-04	3.7E-06	1.5E-03	2.7E-06	7.3E-06
W2.2	1.5E-03	6.5E-06	1.2E-03	5.4E-06	1.1E-03	4.6E-06	8.8E-04	4.3E-06	5.3E-04	2.4E-06	1.0E-03	1.7E-06	4.7E-06
W2.3	5.1E-03	2.2E-05	4.2E-03	1.9E-05	3.9E-03	1.6E-05	3.0E-03	1.5E-05	1.8E-03	8.2E-06	3.4E-03	5.9E-06	1.6E-05
W2.4	3.4E-03	1.5E-05	2.8E-03	1.2E-05	2.6E-03	1.1E-05	2.0E-03	9.8E-06	1.2E-03	5.5E-06	2.3E-03	4.0E-06	1.1E-05
W2.5	2.3E-04	1.0E-06	1.9E-04	8.3E-07	1.7E-04	7.2E-07	1.3E-04	6.6E-07	8.0E-05	3.7E-07	1.5E-04	2.7E-07	7.3E-07
*W2.6													
W2.7	5.09E-04	2.24E-06	4.21E-04	1.85E-06	3.85E-04	1.60E-06	2.99E-04	1.47E-06	1.80E-04	8.25E-07	3.42E-04	5.95E-07	1.64E-06
*W2.8													
W2.9	2.54E-04	4.57E-06	2.10E-04	3.78E-06	1.92E-04	3.27E-06	1.49E-04	3.01E-06	9.00E-05	1.68E-06	1.71E-04	1.21E-06	3.34E-06
*W2.10													
W2.11	5.72E-04	1.03E-05	4.72E-04	8.49E-06	4.32E-04	7.35E-06	3.36E-04	6.76E-06	2.03E-04	3.78E-06	3.84E-04	2.73E-06	7.50E-06
*W2.12													
W3.1	7.21E-03	3.24E-05	5.96E-03	2.68E-05	5.45E-03	2.32E-05	4.23E-03	2.13E-05	2.56E-03	1.19E-05	4.85E-03	8.60E-06	2.37E-05
W3.2	4.98E-04	2.17E-06	4.11E-04	1.79E-06	3.76E-04	1.55E-06	2.92E-04	1.42E-06	1.76E-04	7.97E-07	3.34E-04	5.75E-07	1.58E-06
W3.3	1.77E-02	7.93E-05	1.46E-02	6.55E-05	1.34E-02	5.67E-05	1.04E-02	5.21E-05	6.27E-03	2.92E-05	1.19E-02	2.10E-05	5.79E-05
W3.4	1.23E-03	5.33E-06	1.01E-03	4.41E-06	9.28E-04	3.81E-06	7.21E-04	3.51E-06	4.35E-04	1.96E-06	8.25E-04	1.42E-06	3.89E-06
W3.5	7.21E-04	3.24E-06	5.96E-04	2.68E-06	5.45E-04	2.32E-06	4.23E-04	2.13E-06	2.56E-04	1.19E-06	4.85E-04	8.60E-07	2.37E-06
W3.6	4.98E-05	2.17E-07	4.11E-05	1.79E-07	3.76E-05	1.55E-07	2.92E-05	1.42E-07	1.76E-05	7.97E-08	3.34E-05	5.75E-08	1.58E-07

Scenario Label	Young Toddler Doses (mg/kg/day)		Toddler Doses (mg/kg/day)		Small Child Doses (mg/kg/day)		Child Doses (mg/kg/day)		Teenager Doses (mg/kg/day)		Adult Doses (mg/kg/day)		
	ADR	ADD	ADR	ADD	ADR	ADD	ADR	ADD	ADR	ADD	ADR	ADD - CT	ADD -HE
W3.7	1.77E-03	7.93E-06	1.46E-03	6.55E-06	1.34E-03	5.67E-06	1.04E-03	5.21E-06	6.27E-04	2.92E-06	1.19E-03	2.10E-06	5.79E-06
W3.8	1.23E-04	5.33E-07	1.01E-04	4.41E-07	9.28E-05	3.81E-07	7.21E-05	3.51E-07	4.35E-05	1.96E-07	8.25E-05	1.42E-07	3.89E-07
W3.9	8.07E-04	1.48E-05	6.66E-04	1.22E-05	6.10E-04	1.06E-05	4.74E-04	9.71E-06	2.86E-04	5.44E-06	5.42E-04	3.92E-06	1.08E-05
W3.10	5.59E-05	9.91E-07	4.61E-05	8.18E-07	4.22E-05	7.08E-07	3.28E-05	6.51E-07	1.98E-05	3.65E-07	3.75E-05	2.63E-07	7.23E-07
W3.11	1.97E-03	3.61E-05	1.63E-03	2.98E-05	1.49E-03	2.58E-05	1.16E-03	2.37E-05	6.99E-04	1.33E-05	1.33E-03	9.59E-06	2.64E-05
W3.12	1.38E-04	2.44E-06	1.14E-04	2.02E-06	1.04E-04	1.75E-06	8.09E-05	1.61E-06	4.88E-05	8.99E-07	9.26E-05	6.49E-07	1.78E-06
W4.1	6.88E-03	3.09E-05	5.68E-03	2.55E-05	5.20E-03	2.21E-05	4.04E-03	2.03E-05	2.44E-03	1.14E-05	4.62E-03	8.21E-06	2.26E-05
W4.2	5.92E-04	2.59E-06	4.89E-04	2.14E-06	4.48E-04	1.85E-06	3.48E-04	1.70E-06	2.10E-04	9.54E-07	3.98E-04	6.88E-07	1.89E-06
W4.3	6.88E-04	3.09E-06	5.68E-04	2.55E-06	5.20E-04	2.21E-06	4.04E-04	2.03E-06	2.44E-04	1.14E-06	4.62E-04	8.21E-07	2.26E-06
W4.4	5.92E-05	2.59E-07	4.89E-05	2.14E-07	4.48E-05	1.85E-07	3.48E-05	1.70E-07	2.10E-05	9.54E-08	3.98E-05	6.88E-08	1.89E-07
W4.5	7.69E-04	1.41E-05	6.35E-04	1.16E-05	5.82E-04	1.01E-05	4.52E-04	9.25E-06	2.73E-04	5.18E-06	5.17E-04	3.74E-06	1.03E-05
W4.6	6.63E-05	1.19E-06	5.48E-05	9.82E-07	5.01E-05	8.50E-07	3.89E-05	7.81E-07	2.35E-05	4.37E-07	4.46E-05	3.16E-07	8.68E-07
W5.1	4.76E-01	2.07E-03	3.93E-01	1.71E-03	3.60E-01	1.48E-03	2.79E-01	1.36E-03	1.69E-01	7.63E-04	3.20E-01	5.51E-04	1.51E-03
W5.2	4.76E-02	2.07E-04	3.93E-02	1.71E-04	3.60E-02	1.48E-04	2.79E-02	1.36E-04	1.69E-02	7.63E-05	3.20E-02	5.51E-05	1.51E-04
W5.3	5.34E-02	9.50E-04	4.41E-02	7.85E-04	4.04E-02	6.79E-04	3.14E-02	6.24E-04	1.89E-02	3.50E-04	3.59E-02	2.52E-04	6.93E-04
W5.4	3.83E-01	1.66E-03	3.16E-01	1.37E-03	2.90E-01	1.19E-03	2.25E-01	1.09E-03	1.36E-01	6.11E-04	2.57E-01	4.41E-04	1.21E-03
W5.5	3.83E-02	1.66E-04	3.16E-02	1.37E-04	2.90E-02	1.19E-04	2.25E-02	1.09E-04	1.36E-02	6.11E-05	2.57E-02	4.41E-05	1.21E-04
W5.6	4.29E-02	7.61E-04	3.55E-02	6.29E-04	3.25E-02	5.44E-04	2.52E-02	5.00E-04	1.52E-02	2.80E-04	2.89E-02	2.02E-04	5.56E-04
W5.7	6.50E-01	2.83E-03	5.37E-01	2.34E-03	4.92E-01	2.03E-03	3.82E-01	1.86E-03	2.30E-01	1.04E-03	4.37E-01	7.52E-04	2.07E-03
W5.8	6.50E-02	2.83E-04	5.37E-02	2.34E-04	4.92E-02	2.03E-04	3.82E-02	1.86E-04	2.30E-02	1.04E-04	4.37E-02	7.52E-05	2.07E-04
W5.9	7.30E-02	1.30E-03	6.03E-02	1.07E-03	5.52E-02	9.28E-04	4.29E-02	8.53E-04	2.59E-02	4.78E-04	4.90E-02	3.45E-04	9.48E-04
W5.10	5.22E-01	2.28E-03	4.31E-01	1.88E-03	3.95E-01	1.63E-03	3.07E-01	1.50E-03	1.85E-01	8.38E-04	3.51E-01	6.05E-04	1.66E-03
W5.11	5.22E-02	2.28E-04	4.31E-02	1.88E-04	3.95E-02	1.63E-04	3.07E-02	1.50E-04	1.85E-02	8.38E-05	3.51E-02	6.05E-05	1.66E-04
W5.12	5.88E-02	1.04E-03	4.85E-02	8.60E-04	4.44E-02	7.44E-04	3.45E-02	6.84E-04	2.08E-02	3.83E-04	3.95E-02	2.76E-04	7.60E-04
W6.1	2.19E-03	9.54E-06	1.81E-03	7.88E-06	1.66E-03	6.82E-06	1.29E-03	6.27E-06	7.76E-04	3.51E-06	1.47E-03	2.53E-06	6.96E-06
W6.2	2.19E-04	9.54E-07	1.81E-04	7.88E-07	1.66E-04	6.82E-07	1.29E-04	6.27E-07	7.76E-05	3.51E-07	1.47E-04	2.53E-07	6.96E-07
W6.3	2.45E-04	4.37E-06	2.03E-04	3.61E-06	1.85E-04	3.13E-06	1.44E-04	2.87E-06	8.69E-05	1.61E-06	1.65E-04	1.16E-06	3.19E-06
W6.4	2.10E-03	9.17E-06	1.74E-03	7.57E-06	1.59E-03	6.55E-06	1.24E-03	6.02E-06	7.46E-04	3.37E-06	1.41E-03	2.43E-06	6.69E-06

Scenario Label	Young Toddler Doses (mg/kg/day)		Toddler Doses (mg/kg/day)		Small Child Doses (mg/kg/day)		Child Doses (mg/kg/day)		Teenager Doses (mg/kg/day)		Adult Doses (mg/kg/day)		
	ADR	ADD	ADR	ADD	ADR	ADD	ADR	ADD	ADR	ADD	ADR	ADD - CT	ADD -HE
*W6.5													
*W6.6													
W6.7	9.76E-03	4.26E-05	8.07E-03	3.52E-05	7.38E-03	3.05E-05	5.73E-03	2.80E-05	3.46E-03	1.57E-05	6.56E-03	1.13E-05	3.11E-05
W6.8	9.76E-04	4.26E-06	8.07E-04	3.52E-06	7.38E-04	3.05E-06	5.73E-04	2.80E-06	3.46E-04	1.57E-06	6.56E-04	1.13E-06	3.11E-06
W6.9	1.10E-03	1.94E-05	9.06E-04	1.61E-05	8.29E-04	1.39E-05	6.44E-04	1.28E-05	3.89E-04	7.15E-06	7.37E-04	5.16E-06	1.42E-05
W6.10	9.39E-03	4.07E-05	7.75E-03	3.37E-05	7.10E-03	2.91E-05	5.51E-03	2.68E-05	3.33E-03	1.50E-05	6.31E-03	1.08E-05	2.97E-05
W6.11	9.39E-04	4.07E-06	7.75E-04	3.37E-06	7.10E-04	2.91E-06	5.51E-04	2.68E-06	3.33E-04	1.50E-06	6.31E-04	1.08E-06	2.97E-06
W6.12	1.05E-03	1.87E-05	8.71E-04	1.55E-05	7.98E-04	1.34E-05	6.19E-04	1.23E-05	3.74E-04	6.88E-06	7.09E-04	4.96E-06	1.37E-05
*W8.1													
*W8.2													
W8.3	5.32E-03	6.93E-05	4.40E-03	5.72E-05	4.03E-03	4.95E-05	3.13E-03	4.55E-05	1.89E-03	2.55E-05	3.58E-03	1.84E-05	5.06E-05
W8.4	5.32E-04	6.93E-06	4.40E-04	5.72E-06	4.03E-04	4.95E-06	3.13E-04	4.55E-06	1.89E-04	2.55E-06	3.58E-04	1.84E-06	5.06E-06
*W9.1													
*W9.2													
W9.3	1.03E-01	4.67E-04	8.51E-02	3.86E-04	7.79E-02	3.34E-04	6.05E-02	3.07E-04	3.65E-02	1.72E-04	6.93E-02	1.24E-04	3.41E-04
W9.4	5.32E-04	4.67E-05	4.40E-04	3.86E-05	4.03E-04	3.34E-05	3.13E-04	3.07E-05	1.89E-04	1.72E-05	3.58E-04	1.24E-05	3.41E-05
W10.1	9.91E-03	4.44E-05	8.18E-03	3.67E-05	7.49E-03	3.18E-05	5.82E-03	2.92E-05	3.51E-03	1.64E-05	6.66E-03	1.18E-05	3.24E-05
W10.2	9.91E-04	4.44E-06	8.18E-04	3.67E-06	7.49E-04	3.18E-06	5.82E-04	2.92E-06	3.51E-04	1.64E-06	6.66E-04	1.18E-06	3.24E-06
W10.3	1.11E-03	2.02E-05	9.16E-04	1.67E-05	8.38E-04	1.44E-05	6.51E-04	1.33E-05	3.93E-04	7.43E-06	7.45E-04	5.36E-06	1.47E-05
W10.4	5.14E-04	2.22E-06	4.24E-04	1.84E-06	3.88E-04	1.59E-06	3.02E-04	1.46E-06	1.82E-04	8.18E-07	3.45E-04	5.90E-07	1.62E-06
*W10.5													
*W10.6													
W10.7	1.18E-02	5.30E-05	9.74E-03	4.38E-05	8.92E-03	3.79E-05	6.93E-03	3.48E-05	4.18E-03	1.95E-05	7.93E-03	1.41E-05	3.87E-05
W10.8	1.18E-03	5.30E-06	9.74E-04	4.38E-06	8.92E-04	3.79E-06	6.93E-04	3.48E-06	4.18E-04	1.95E-06	7.93E-04	1.41E-06	3.87E-06
W10.9	1.32E-03	2.41E-05	1.09E-03	1.99E-05	9.97E-04	1.72E-05	7.74E-04	1.58E-05	4.67E-04	8.86E-06	8.86E-04	6.39E-06	1.76E-05
W10.10	6.09E-04	2.65E-06	5.03E-04	2.19E-06	4.61E-04	1.89E-06	3.58E-04	1.74E-06	2.16E-04	9.74E-07	4.10E-04	7.03E-07	1.93E-06
*W10.11													
*W10.12													

Scenario Label	Young Toddler Doses (mg/kg/day)		Toddler Doses (mg/kg/day)		Small Child Doses (mg/kg/day)		Child Doses (mg/kg/day)		Teenager Doses (mg/kg/day)		Adult Doses (mg/kg/day)		
	ADR	ADD	ADR	ADD	ADR	ADD	ADR	ADD	ADR	ADD	ADR	ADD - CT	ADD -HE
W12.1	3.73E-05	1.66E-07	3.08E-05	1.38E-07	2.82E-05	1.19E-07	2.19E-05	1.09E-07	1.32E-05	6.13E-08	2.51E-05	4.42E-08	1.22E-07
W12.2	4.18E-05	7.61E-07	3.45E-05	6.29E-07	3.16E-05	5.44E-07	2.45E-05	5.00E-07	1.48E-05	2.80E-07	2.81E-05	2.02E-07	5.56E-07
*W12.3													
*W12.4													
W12.5	7.46E-05	3.33E-07	6.16E-05	2.75E-07	5.64E-05	2.38E-07	4.38E-05	2.19E-07	2.64E-05	1.23E-07	5.01E-05	8.85E-08	2.43E-07
W12.6	8.34E-05	1.52E-06	6.89E-05	1.26E-06	6.31E-05	1.09E-06	4.90E-05	1.00E-06	2.96E-05	5.60E-07	5.61E-05	4.04E-07	1.11E-06
*W12.7													
*W12.8													
All Scenarios - Minimum	3.73E-05	1.66E-07	3.08E-05	1.38E-07	2.82E-05	1.19E-07	2.19E-05	1.09E-07	1.32E-05	6.13E-08	2.51E-05	4.42E-08	1.22E-07
All Scenarios - Maximum	6.50E-01	2.83E-03	5.37E-01	2.34E-03	4.92E-01	2.03E-03	3.82E-01	1.86E-03	2.30E-01	1.04E-03	4.37E-01	7.52E-04	2.07E-03
ADR = acute dose rate; ADD = average daily dose; HE = high-end residency, CT = central tendency residency													

Table_Apx G-21. Highly Exposed Aggregate Acute Dose Rate and Average Daily Doses (mg/kg/day) for Modeled Fish Ingestion and Background

Scenario Label	Young Toddler Doses (mg/kg/day)		Toddler Doses (mg/kg/day)		Small Child Doses (mg/kg/day)		Child Doses (mg/kg/day)		Teenager Doses (mg/kg/day)		Adult Doses (mg/kg/day)		
	ADR	ADD	ADR	ADD	ADR	ADD	ADR	ADD	ADR	ADD	ADR	ADD - CT	ADD -HE
W1.1	4.79E-03	4.99E-05	3.95E-03	3.52E-05	3.61E-03	2.82E-05	2.80E-03	2.21E-05	1.69E-03	1.19E-05	3.21E-03	8.46E-06	1.81E-05
W1.2	3.96E-03	4.61E-05	3.27E-03	3.21E-05	2.99E-03	2.55E-05	2.32E-03	1.96E-05	1.40E-03	1.06E-05	2.65E-03	7.47E-06	1.54E-05
W1.3	2.40E-02	1.33E-04	1.98E-02	1.04E-04	1.81E-02	8.79E-05	1.41E-02	7.70E-05	8.49E-03	4.27E-05	1.61E-02	3.06E-05	7.91E-05
W1.4	1.92E-02	1.15E-04	1.58E-02	8.89E-05	1.45E-02	7.47E-05	1.13E-02	6.48E-05	6.79E-03	3.58E-05	1.29E-02	2.57E-05	6.55E-05
W1.5	5.38E-03	1.25E-04	4.44E-03	9.69E-05	4.06E-03	8.16E-05	3.15E-03	7.11E-05	1.90E-03	3.94E-05	3.61E-03	2.83E-05	7.26E-05
W1.6	4.44E-03	1.07E-04	3.66E-03	8.25E-05	3.35E-03	6.91E-05	2.60E-03	5.97E-05	1.57E-03	3.30E-05	2.97E-03	2.37E-05	5.99E-05
W1.7	2.69E-02	5.07E-04	2.22E-02	4.13E-04	2.03E-02	3.55E-04	1.58E-02	3.22E-04	9.52E-03	1.80E-04	1.81E-02	1.30E-04	3.52E-04
W1.8	2.22E-02	4.22E-04	1.84E-02	3.42E-04	1.68E-02	2.94E-04	1.30E-02	2.66E-04	7.87E-03	1.49E-04	1.49E-02	1.07E-04	2.90E-04
W2.1	2.29E-03	3.91E-05	1.89E-03	2.64E-05	1.73E-03	2.05E-05	1.34E-03	1.50E-05	8.06E-04	7.98E-06	1.53E-03	5.61E-06	1.03E-05
W2.2	1.52E-03	3.56E-05	1.25E-03	2.35E-05	1.14E-03	1.80E-05	8.86E-04	1.27E-05	5.34E-04	6.69E-06	1.01E-03	4.68E-06	7.70E-06
W2.3	5.12E-03	5.15E-05	4.22E-03	3.66E-05	3.86E-03	2.94E-05	3.00E-03	2.32E-05	1.81E-03	1.25E-05	3.43E-03	8.90E-06	1.93E-05
W2.4	3.47E-03	4.41E-05	2.86E-03	3.05E-05	2.61E-03	2.41E-05	2.03E-03	1.83E-05	1.22E-03	9.80E-06	2.32E-03	6.93E-06	1.39E-05
W2.5	2.55E-04	3.01E-05	2.05E-04	1.89E-05	1.85E-04	1.41E-05	1.41E-04	9.12E-06	8.45E-05	4.67E-06	1.55E-04	3.22E-06	3.69E-06
*W2.6													
W2.7	5.38E-04	3.14E-05	4.39E-04	1.99E-05	3.99E-04	1.50E-05	3.08E-04	9.93E-06	1.85E-04	5.12E-06	3.46E-04	3.55E-06	4.59E-06
*W2.8													
W2.9	2.83E-04	3.37E-05	2.28E-04	2.19E-05	2.05E-04	1.67E-05	1.58E-04	1.15E-05	9.43E-05	5.98E-06	1.74E-04	4.17E-06	6.29E-06
*W2.10													
W2.11	6.01E-04	3.94E-05	4.90E-04	2.66E-05	4.46E-04	2.07E-05	3.44E-04	1.52E-05	2.07E-04	8.08E-06	3.88E-04	5.68E-06	1.05E-05
*W2.12													
W3.1	7.24E-03	6.15E-05	5.97E-03	4.49E-05	5.47E-03	3.66E-05	4.24E-03	2.98E-05	2.56E-03	1.62E-05	4.86E-03	1.16E-05	2.66E-05
W3.2	5.27E-04	3.13E-05	4.29E-04	1.99E-05	3.90E-04	1.49E-05	3.01E-04	9.89E-06	1.81E-04	5.09E-06	3.38E-04	3.53E-06	4.54E-06
W3.3	1.77E-02	1.08E-04	1.46E-02	8.36E-05	1.34E-02	7.01E-05	1.04E-02	6.06E-05	6.28E-03	3.35E-05	1.19E-02	2.40E-05	6.08E-05
W3.4	1.26E-03	3.45E-05	1.03E-03	2.25E-05	9.42E-04	1.72E-05	7.29E-04	1.20E-05	4.39E-04	6.26E-06	8.29E-04	4.37E-06	6.85E-06
W3.5	7.50E-04	3.24E-05	6.14E-04	2.08E-05	5.59E-04	1.57E-05	4.32E-04	1.06E-05	2.60E-04	5.49E-06	4.88E-04	3.82E-06	5.32E-06
W3.6	7.89E-05	2.94E-05	5.92E-05	1.83E-05	5.10E-05	1.35E-05	3.77E-05	8.60E-06	2.19E-05	4.38E-06	3.64E-05	3.01E-06	3.11E-06

Scenario Label	Young Toddler Doses (mg/kg/day)		Toddler Doses (mg/kg/day)		Small Child Doses (mg/kg/day)		Child Doses (mg/kg/day)		Teenager Doses (mg/kg/day)		Adult Doses (mg/kg/day)		
	ADR	ADD	ADR	ADD	ADR	ADD	ADR	ADD	ADR	ADD	ADR	ADD - CT	ADD -HE
W3.7	1.80E-03	3.71E-05	1.48E-03	2.46E-05	1.35E-03	1.91E-05	1.05E-03	1.37E-05	6.32E-04	7.21E-06	1.19E-03	5.06E-06	8.74E-06
W3.8	1.52E-04	2.97E-05	1.19E-04	1.85E-05	1.06E-04	1.38E-05	8.05E-05	8.81E-06	4.78E-05	4.49E-06	8.56E-05	3.10E-06	3.35E-06
W3.9	8.36E-04	4.39E-05	6.84E-04	3.03E-05	6.23E-04	2.40E-05	4.82E-04	1.82E-05	2.90E-04	9.73E-06	5.46E-04	6.88E-06	1.37E-05
W3.10	8.50E-05	3.01E-05	6.42E-05	1.89E-05	5.56E-05	1.41E-05	4.13E-05	9.11E-06	2.41E-05	4.66E-06	4.05E-05	3.22E-06	3.68E-06
W3.11	2.00E-03	6.52E-05	1.65E-03	4.79E-05	1.51E-03	3.92E-05	1.17E-03	3.22E-05	7.04E-04	1.76E-05	1.33E-03	1.25E-05	2.93E-05
W3.12	1.67E-04	3.16E-05	1.32E-04	2.01E-05	1.18E-04	1.51E-05	8.94E-05	1.01E-05	5.31E-05	5.20E-06	9.57E-05	3.60E-06	4.74E-06
W4.1	6.91E-03	6.01E-05	5.70E-03	4.36E-05	5.21E-03	3.55E-05	4.05E-03	2.88E-05	2.44E-03	1.57E-05	4.63E-03	1.12E-05	2.55E-05
W4.2	6.21E-04	3.17E-05	5.07E-04	2.02E-05	4.61E-04	1.52E-05	3.56E-04	1.02E-05	2.14E-04	5.25E-06	4.01E-04	3.64E-06	4.85E-06
W4.3	7.17E-04	3.22E-05	5.86E-04	2.06E-05	5.33E-04	1.56E-05	4.12E-04	1.05E-05	2.48E-04	5.44E-06	4.66E-04	3.78E-06	5.21E-06
W4.4	8.83E-05	2.94E-05	6.70E-05	1.83E-05	5.82E-05	1.36E-05	4.32E-05	8.63E-06	2.53E-05	4.39E-06	4.28E-05	3.02E-06	3.15E-06
W4.5	7.98E-04	4.32E-05	6.53E-04	2.97E-05	5.95E-04	2.35E-05	4.60E-04	1.77E-05	2.77E-04	9.48E-06	5.20E-04	6.69E-06	1.32E-05
W4.6	9.54E-05	3.03E-05	7.29E-05	1.91E-05	6.35E-05	1.42E-05	4.74E-05	9.24E-06	2.78E-05	4.73E-06	4.76E-05	3.27E-06	3.82E-06
W5.1	4.76E-01	2.10E-03	3.93E-01	1.73E-03	3.60E-01	1.50E-03	2.79E-01	1.37E-03	1.69E-01	7.67E-04	3.20E-01	5.54E-04	1.52E-03
W5.2	4.76E-02	2.37E-04	3.93E-02	1.89E-04	3.60E-02	1.62E-04	2.80E-02	1.45E-04	1.69E-02	8.06E-05	3.20E-02	5.80E-05	1.54E-04
W5.3	5.34E-02	9.79E-04	4.41E-02	8.03E-04	4.04E-02	6.93E-04	3.14E-02	6.33E-04	1.89E-02	3.54E-04	3.59E-02	2.55E-04	6.96E-04
W5.4	3.83E-01	1.69E-03	3.16E-01	1.39E-03	2.90E-01	1.20E-03	2.25E-01	1.10E-03	1.36E-01	6.16E-04	2.58E-01	4.44E-04	1.22E-03
W5.5	3.83E-02	1.95E-04	3.17E-02	1.55E-04	2.90E-02	1.32E-04	2.25E-02	1.18E-04	1.36E-02	6.54E-05	2.58E-02	4.70E-05	1.24E-04
W5.6	4.30E-02	7.90E-04	3.55E-02	6.47E-04	3.25E-02	5.58E-04	2.52E-02	5.09E-04	1.52E-02	2.84E-04	2.89E-02	2.05E-04	5.59E-04
W5.7	6.50E-01	2.86E-03	5.37E-01	2.36E-03	4.92E-01	2.04E-03	3.82E-01	1.87E-03	2.30E-01	1.05E-03	4.37E-01	7.55E-04	2.07E-03
W5.8	6.50E-02	3.12E-04	5.37E-02	2.52E-04	4.92E-02	2.16E-04	3.82E-02	1.95E-04	2.30E-02	1.09E-04	4.37E-02	7.82E-05	2.10E-04
W5.9	7.30E-02	1.33E-03	6.03E-02	1.09E-03	5.52E-02	9.42E-04	4.29E-02	8.62E-04	2.59E-02	4.82E-04	4.91E-02	3.48E-04	9.51E-04
W5.10	5.22E-01	2.31E-03	4.31E-01	1.90E-03	3.95E-01	1.64E-03	3.07E-01	1.51E-03	1.85E-01	8.42E-04	3.52E-01	6.08E-04	1.67E-03
W5.11	5.23E-02	2.57E-04	4.32E-02	2.06E-04	3.95E-02	1.76E-04	3.07E-02	1.58E-04	1.85E-02	8.81E-05	3.52E-02	6.34E-05	1.69E-04
W5.12	5.88E-02	1.07E-03	4.86E-02	8.78E-04	4.44E-02	7.58E-04	3.45E-02	6.92E-04	2.08E-02	3.87E-04	3.95E-02	2.79E-04	7.63E-04
W6.1	2.22E-03	3.87E-05	1.83E-03	2.60E-05	1.67E-03	2.02E-05	1.29E-03	1.47E-05	7.81E-04	7.81E-06	1.48E-03	5.49E-06	9.92E-06
W6.2	2.48E-04	3.01E-05	1.99E-04	1.89E-05	1.79E-04	1.41E-05	1.37E-04	9.09E-06	8.19E-05	4.65E-06	1.50E-04	3.21E-06	3.65E-06
W6.3	2.74E-04	3.35E-05	2.21E-04	2.17E-05	1.99E-04	1.65E-05	1.52E-04	1.13E-05	9.12E-05	5.91E-06	1.68E-04	4.12E-06	6.15E-06
W6.4	2.13E-03	3.83E-05	1.76E-03	2.57E-05	1.60E-03	1.99E-05	1.24E-03	1.45E-05	7.50E-04	7.67E-06	1.42E-03	5.39E-06	9.65E-06

Scenario Label	Young Toddler Doses (mg/kg/day)		Toddler Doses (mg/kg/day)		Small Child Doses (mg/kg/day)		Child Doses (mg/kg/day)		Teenager Doses (mg/kg/day)		Adult Doses (mg/kg/day)		
	ADR	ADD	ADR	ADD	ADR	ADD	ADR	ADD	ADR	ADD	ADR	ADD - CT	ADD -HE
*W6.5													
*W6.6													
W6.7	9.79E-03	7.17E-05	8.08E-03	5.33E-05	7.40E-03	4.38E-05	5.74E-03	3.65E-05	3.46E-03	2.00E-05	6.57E-03	1.43E-05	3.40E-05
W6.8	1.01E-03	3.34E-05	8.25E-04	2.16E-05	7.52E-04	1.64E-05	5.82E-04	1.13E-05	3.50E-04	5.86E-06	6.60E-04	4.09E-06	6.07E-06
W6.9	1.13E-03	4.86E-05	9.24E-04	3.42E-05	8.43E-04	2.73E-05	6.53E-04	2.12E-05	3.93E-04	1.15E-05	7.41E-04	8.12E-06	1.72E-05
W6.10	9.41E-03	6.99E-05	7.77E-03	5.17E-05	7.11E-03	4.25E-05	5.52E-03	3.52E-05	3.33E-03	1.93E-05	6.32E-03	1.38E-05	3.27E-05
W6.11	9.68E-04	3.32E-05	7.93E-04	2.15E-05	7.23E-04	1.63E-05	5.60E-04	1.11E-05	3.37E-04	5.80E-06	6.35E-04	4.04E-06	5.93E-06
W6.12	1.08E-03	4.78E-05	8.89E-04	3.35E-05	8.11E-04	2.68E-05	6.28E-04	2.08E-05	3.78E-04	1.12E-05	7.13E-04	7.92E-06	1.66E-05
W8.1													
*W8.2													
W8.3	5.35E-03	9.84E-05	4.42E-03	7.53E-05	4.04E-03	6.29E-05	3.14E-03	5.40E-05	1.89E-03	2.98E-05	3.59E-03	2.13E-05	5.35E-05
*W8.4	5.62E-04	3.61E-05	4.58E-04	2.38E-05	4.16E-04	1.83E-05	3.21E-04	1.30E-05	1.93E-04	6.85E-06	3.61E-04	4.79E-06	8.01E-06
W9.1													
W9.2													
W9.3	3.56E-02	4.96E-04	2.94E-02	4.04E-04	2.69E-02	3.47E-04	2.09E-02	3.15E-04	1.26E-02	1.76E-04	2.4E-02	1.27E-04	3.44E-04
W9.4	3.58E-03	7.58E-05	2.95E-03	5.66E-05	2.70E-03	4.68E-05	2.10E-03	3.91E-05	1.26E-03	2.15E-05	2.4E-03	1.53E-05	3.70E-05
W10.1	9.94E-03	7.36E-05	8.20E-03	5.48E-05	7.51E-03	4.52E-05	5.83E-03	3.77E-05	3.52E-03	2.07E-05	6.67E-03	1.48E-05	3.54E-05
W10.2	1.02E-03	3.36E-05	8.37E-04	2.18E-05	7.63E-04	1.66E-05	5.90E-04	1.14E-05	3.55E-04	5.93E-06	6.70E-04	4.14E-06	6.20E-06
W10.3	1.14E-03	4.93E-05	9.34E-04	3.48E-05	8.52E-04	2.78E-05	6.59E-04	2.17E-05	3.97E-04	1.17E-05	7.49E-04	8.31E-06	1.77E-05
W10.4	5.43E-04	3.14E-05	4.42E-04	1.99E-05	4.02E-04	1.50E-05	3.10E-04	9.92E-06	1.86E-04	5.11E-06	3.49E-04	3.55E-06	4.58E-06
*W10.5													
*W10.6													
W10.7	1.18E-02	8.21E-05	9.76E-03	6.18E-05	8.93E-03	5.13E-05	6.94E-03	4.33E-05	4.18E-03	2.38E-05	7.94E-03	1.70E-05	4.16E-05
W10.8	1.21E-03	3.44E-05	9.92E-04	2.25E-05	9.05E-04	1.72E-05	7.01E-04	1.19E-05	4.22E-04	6.25E-06	7.97E-04	4.36E-06	6.82E-06
W10.9	1.35E-03	5.32E-05	1.11E-03	3.80E-05	1.01E-03	3.06E-05	7.83E-04	2.43E-05	4.72E-04	1.32E-05	8.91E-04	9.35E-06	2.05E-05
W10.10	6.38E-04	3.18E-05	5.21E-04	2.03E-05	4.74E-04	1.53E-05	3.66E-04	1.02E-05	2.20E-04	5.27E-06	4.13E-04	3.66E-06	4.89E-06
*W10.11													
*W10.12													

Scenario Label	Young Toddler Doses (mg/kg/day)		Toddler Doses (mg/kg/day)		Small Child Doses (mg/kg/day)		Child Doses (mg/kg/day)		Teenager Doses (mg/kg/day)		Adult Doses (mg/kg/day)		
	ADR	ADD	ADR	ADD	ADR	ADD	ADR	ADD	ADR	ADD	ADR	ADD - CT	ADD -HE
W12.1	6.64E-05	2.93E-05	4.89E-05	1.82E-05	4.16E-05	1.35E-05	3.04E-05	8.57E-06	1.75E-05	4.36E-06	2.80E-05	3.00E-06	3.08E-06
W12.2	7.09E-05	2.99E-05	5.26E-05	1.87E-05	4.50E-05	1.39E-05	3.30E-05	8.96E-06	1.91E-05	4.58E-06	3.11E-05	3.16E-06	3.51E-06
*W12.3													
*W12.4													
W12.5	1.04E-04	2.95E-05	7.97E-05	1.84E-05	6.98E-05	1.36E-05	5.23E-05	8.68E-06	3.07E-05	4.42E-06	5.31E-05	3.04E-06	3.20E-06
W12.6	1.13E-04	3.07E-05	8.70E-05	1.93E-05	7.65E-05	1.45E-05	5.75E-05	9.46E-06	3.39E-05	4.86E-06	5.91E-05	3.36E-06	4.07E-06
*W12.7													
*W12.8													
All Scenarios - Minimum	6.64E-05	2.93E-05	4.89E-05	1.82E-05	4.16E-05	1.35E-05	3.04E-05	8.57E-06	1.75E-05	4.36E-06	2.80E-05	3.00E-06	3.08E-06
All Scenarios - Maximum	6.50E-01	2.86E-03	5.37E-01	2.36E-03	4.92E-01	2.04E-03	3.82E-01	1.87E-03	2.30E-01	1.05E-03	4.37E-01	7.55E-04	2.07E-03
ADR = acute dose rate; ADD = average daily dose; HE = high-end residency, CT = central tendency residency													

G.4 Scenario H2: Near Facility Suspended Particulates in Air — Inhalation

EPA/OPPT's Integrated Indoor-Outdoor Air Calculation (IIOAC) was used to estimate ambient air concentrations for highly exposed groups living near facilities. IIOAC is based on a set of pre-run AERMOD dispersion scenarios at a variety of meteorological and land-use settings. For the source types of interest in HBCD modeling, users are required to enter: (1) emission parameters – emission source type, number of emission scenarios, number of releases per scenario, mass released per day, release duration, number of release days, and release pattern; (2) system parameters – applicable only for fugitive sources where an area must be specified; and (3) location parameters – urban or rural setting, particle size/vapor, and climate region. IIOAC outputs of daily-averaged air concentration, annual-averaged air concentration, and doses are provided as central tendency and high-end estimates at two distances: fence line (100 m from source) and community (averaged across 100 to 1,000 m from the source).

IIOAC calculates ambient air concentration based on the release duration and number of days of release per year entered by the user (*e.g.*, release occurs 4 hrs/day for 52 days in a year). An adjusted emission rate is first calculated, as shown in Equation_Apx G-1, to take into account the release duration and convert the user-defined mass released per day into g/s.

Equation_Apx G-1

$$ER_{adj} = \frac{ER}{h} \cdot 0.2778$$

where ER_{adj} = adjusted emission rate [g/s]
 ER = user-defined mass released per day [kg/day]
 h = emission duration [hrs/day]
 0.2778 = conversion factor from kg/hr to g/s

Air concentrations are calculated in Equation_Apx G-2 by scaling the post-processed AERMOD result, obtained based on an emission of 1 g/s, by the adjusted emission rate. For fugitive sources, scaling by just the adjusted emission rate gives an air concentration corresponding to an area size of 100 m², the same as that used in the AERMOD runs. To account for a different area size, an area size scaling factor, SF_j , is applied.

Equation_Apx G-2

$$C_{outdoor} = \frac{ER_{adj}}{1 \text{ g/s}} \cdot SF_j \cdot \text{Postprocessed AERMOD result}$$

where $C_{outdoor}$ = outdoor air concentration [μg/m³]
 ER_{adj} = adjusted emission rate [g/s]
 SF_j = scaling factor for fugitive area size j [-]; set to 1 for point sources

For point and fugitive sources, three particle size scenarios are available:

- Fine particles (with a mass-mean aerodynamic diameter of 2.5 μm),
- Coarse particles (with a mass-mean aerodynamic diameter of 10 μm), and
- Vapor (no particles).

All calculated air concentrations of fine and coarse particles are capped by an upper limit equal to the National Ambient Air Quality Standards (NAAQS) for particulate matter (PM) ([U.S. EPA 2009a](#)). These limits are 35 and 150 μm^3 for fine and coarse particles (*i.e.*, the NAAQS for PM_{2.5} and PM₁₀), respectively, over 24-hr. For vapors, the chemical is released in gaseous form and therefore there is no transfer from one phase to another. IIOAC currently does not set an upper limit for point and fugitive sources in vapor form. Air concentrations are then calculated by multiplying the ambient air concentration by an indoor-outdoor ratio.

In modeling ambient air concentration for highly exposed groups living near facilities, twelve emission scenarios were considered, based on the conditions of use defined in the Section 1.4. For scenarios with site-specific information, this information was used in the IIOAC model runs. When site-specific information was not unknown, the following default parameters were used:

- i. Emission parameters:
 - a. Source type: Both stack and fugitive.
 - b. Emission duration: 24 hours.
 - c. Release pattern: Conservative pattern of release was used for all runs.
- ii. System parameters:
 - a. Fugitive source area: 100 m²
- iii. Location parameters:
 - a. Population setting: Rural
 - b. Particle size: Coarse - In the United States, standard grade HBCD powder is defined as a mean particle size of 20 to 150 μm ; therefore, coarse particles was selected for use in the IIOAC runs.
 - c. Climate region default: Three regions were used:
 - i. West north central to obtain central tendency estimates for both air concentration and particle deposition.
 - ii. South (coastal) to obtain high-end estimates when considering only air concentration.
 - iii. East north central to obtain high-end estimates when considering both air concentration and particle deposition.

Table_Apx G-22. Highly Exposed Acute Dose Rate (mg/kg/day) for Modeled Air Only

Label	Source Type	Average Air Concentration ($\mu\text{g}/\text{m}^3$)		ADR – Modeled Air (mg/kg/d)						
		Daily	Annual	Infant	Young Toddler	Toddler	Small Child	Child	Teen	Adult
1.1	Fugitive	1.17E+00	8.74E-04	1.37E-03	1.31E-03	1.16E-03	8.68E-04	6.10E-04	4.51E-04	3.08E-04
1.2	Fugitive	6.72E-02	8.82E-04	7.90E-05	7.55E-05	6.67E-05	4.99E-05	3.51E-05	2.59E-05	1.77E-05
1.3	Fugitive	5.85E+00	4.37E-03	6.87E-03	6.57E-03	5.81E-03	4.34E-03	3.05E-03	2.25E-03	1.54E-03
1.4	Fugitive	3.36E-01	4.41E-03	3.95E-04	3.77E-04	3.34E-04	2.49E-04	1.75E-04	1.30E-04	8.86E-05
1.5	Stack	1.71E-01	6.67E-04	2.01E-04	1.92E-04	1.70E-04	1.27E-04	8.92E-05	6.59E-05	4.50E-05
1.6	Stack	1.17E-02	6.72E-04	1.38E-05	1.32E-05	1.16E-05	8.70E-06	6.12E-06	4.52E-06	3.09E-06
1.7	Stack	8.54E-01	3.33E-03	1.00E-03	9.59E-04	8.48E-04	6.34E-04	4.46E-04	3.29E-04	2.25E-04
1.8	Stack	5.86E-02	3.36E-03	6.89E-05	6.58E-05	5.82E-05	4.35E-05	3.06E-05	2.26E-05	1.55E-05
1.9	Incineration	6.31E-03	2.56E-04	7.42E-06	7.09E-06	6.27E-06	4.68E-06	3.30E-06	2.43E-06	1.67E-06
1.10	Incineration	3.28E-04	2.56E-04	3.85E-07	3.68E-07	3.25E-07	2.43E-07	1.71E-07	1.26E-07	8.64E-08
1.11	Incineration	3.16E-02	1.28E-03	3.71E-05	3.54E-05	3.13E-05	2.34E-05	1.65E-05	1.22E-05	8.33E-06

Label	Source Type	Average Air Concentration ($\mu\text{g}/\text{m}^3$)		ADR – Modeled Air ($\text{mg}/\text{kg}/\text{d}$)						
		Daily	Annual	Infant	Young Toddler	Toddler	Small Child	Child	Teen	Adult
1.12	Incineration	1.64E-03	1.28E-03	1.92E-06	1.84E-06	1.63E-06	1.22E-06	8.55E-07	6.32E-07	4.32E-07
2.1	Fugitive	2.21E-02	5.35E-06	2.59E-05	2.48E-05	2.19E-05	1.64E-05	1.15E-05	8.51E-06	5.82E-06
2.2	Fugitive	3.43E-03	5.35E-06	4.03E-06	3.85E-06	3.41E-06	2.55E-06	1.79E-06	1.32E-06	9.05E-07
2.3	Fugitive	2.64E-02	6.39E-06	3.10E-05	2.96E-05	2.62E-05	1.96E-05	1.38E-05	1.02E-05	6.95E-06
2.4	Fugitive	4.10E-03	6.39E-06	4.82E-06	4.60E-06	4.07E-06	3.04E-06	2.14E-06	1.58E-06	1.08E-06
2.5	Stack	3.18E-03	4.08E-06	3.74E-06	3.57E-06	3.16E-06	2.36E-06	1.66E-06	1.23E-06	8.40E-07
2.6	Stack	4.90E-04	4.09E-06	5.75E-07	5.50E-07	4.86E-07	3.63E-07	2.56E-07	1.89E-07	1.29E-07
2.7	Stack	3.80E-03	4.87E-06	4.47E-06	4.27E-06	3.77E-06	2.82E-06	1.98E-06	1.47E-06	1.00E-06
2.8	Stack	5.85E-04	4.88E-06	6.87E-07	6.57E-07	5.81E-07	4.34E-07	3.05E-07	2.25E-07	1.54E-07
3.1	Fugitive	2.77E+00	5.05E-05	3.25E-03	3.11E-03	2.75E-03	2.05E-03	1.45E-03	1.07E-03	7.30E-04
3.2	Fugitive	1.30E-01	5.06E-05	1.53E-04	1.47E-04	1.30E-04	9.68E-05	6.81E-05	5.03E-05	3.44E-05
3.3	Stack	3.50E-01	3.86E-05	4.11E-04	3.93E-04	3.47E-04	2.59E-04	1.83E-04	1.35E-04	9.22E-05
3.4	Stack	1.85E-02	3.86E-05	2.18E-05	2.08E-05	1.84E-05	1.37E-05	9.67E-06	7.14E-06	4.88E-06
4.1	Fugitive	3.49E-01	6.36E-06	4.10E-04	3.91E-04	3.46E-04	2.59E-04	1.82E-04	1.34E-04	9.19E-05
4.2	Fugitive	1.64E-02	6.37E-06	1.93E-05	1.84E-05	1.63E-05	1.22E-05	8.58E-06	6.33E-06	4.33E-06
4.3	Stack	4.40E-02	4.86E-06	5.17E-05	4.94E-05	4.37E-05	3.27E-05	2.30E-05	1.70E-05	1.16E-05
4.4	Stack	2.33E-03	4.86E-06	2.74E-06	2.62E-06	2.31E-06	1.73E-06	1.22E-06	8.99E-07	6.15E-07
4.5	Stack	1.89E-01	2.52E-05	2.22E-04	2.12E-04	1.87E-04	1.40E-04	9.86E-05	7.28E-05	4.98E-05
4.6	Stack	1.09E-02	2.51E-05	1.28E-05	1.22E-05	1.08E-05	8.06E-06	5.67E-06	4.19E-06	2.87E-06
4.7	Incineration	1.61E-01	1.89E-04	1.90E-04	1.81E-04	1.60E-04	1.20E-04	8.42E-05	6.22E-05	4.26E-05
4.8	Incineration	6.84E-03	1.89E-04	8.04E-06	7.68E-06	6.79E-06	5.07E-06	3.57E-06	2.64E-06	1.80E-06
4.9	Stack	2.90E+00	3.46E-04	3.40E-03	3.25E-03	2.88E-03	2.15E-03	1.51E-03	1.12E-03	7.64E-04
4.10	Stack	1.43E-01	3.46E-04	1.68E-04	1.61E-04	1.42E-04	1.06E-04	7.47E-05	5.52E-05	3.78E-05
4.11	Incineration	2.30E-01	1.78E-04	2.70E-04	2.58E-04	2.28E-04	1.71E-04	1.20E-04	8.86E-05	6.06E-05
4.12	Incineration	7.14E-03	1.79E-04	8.39E-06	8.02E-06	7.09E-06	5.30E-06	3.73E-06	2.75E-06	1.88E-06
5.1	Stack	3.20E-01	6.67E-04	3.76E-04	3.59E-04	3.18E-04	2.37E-04	1.67E-04	1.23E-04	8.44E-05
5.2	Stack	3.16E-02	6.69E-04	3.72E-05	3.55E-05	3.14E-05	2.35E-05	1.65E-05	1.22E-05	8.34E-06
5.3	Stack	1.60E+00	3.33E-03	1.88E-03	1.80E-03	1.59E-03	1.19E-03	8.35E-04	6.17E-04	4.22E-04
5.4	Stack	1.58E-01	3.35E-03	1.86E-04	1.78E-04	1.57E-04	1.17E-04	8.26E-05	6.10E-05	4.17E-05
5.5	Fugitive	2.25E+00	8.74E-04	2.65E-03	2.53E-03	2.24E-03	1.67E-03	1.18E-03	8.69E-04	5.95E-04
5.6	Fugitive	1.97E-01	8.77E-04	2.31E-04	2.21E-04	1.96E-04	1.46E-04	1.03E-04	7.59E-05	5.19E-05
5.7	Fugitive	1.13E+01	4.37E-03	1.32E-02	1.27E-02	1.12E-02	8.36E-03	5.89E-03	4.35E-03	2.97E-03
5.8	Fugitive	9.85E-01	4.38E-03	1.16E-03	1.11E-03	9.78E-04	7.31E-04	5.14E-04	3.80E-04	2.60E-04
5.9	Incineration	2.61E-01	5.36E-03	3.06E-04	2.93E-04	2.59E-04	1.93E-04	1.36E-04	1.00E-04	6.87E-05
5.10	Incineration	2.09E-02	5.37E-03	2.46E-05	2.35E-05	2.08E-05	1.55E-05	1.09E-05	8.07E-06	5.52E-06
5.11	Incineration	4.96E-01	1.02E-02	5.83E-04	5.57E-04	4.93E-04	3.68E-04	2.59E-04	1.91E-04	1.31E-04
5.12	Incineration	3.99E-02	1.02E-02	4.69E-05	4.48E-05	3.96E-05	2.96E-05	2.08E-05	1.54E-05	1.05E-05
6.1	Fugitive	1.14E-01	4.42E-05	1.34E-04	1.28E-04	1.13E-04	8.46E-05	5.95E-05	4.40E-05	3.01E-05
6.2	Fugitive	3.40E-03	4.46E-05	3.99E-06	3.82E-06	3.37E-06	2.52E-06	1.77E-06	1.31E-06	8.96E-07
6.3	Fugitive	5.07E-01	1.97E-04	5.96E-04	5.70E-04	5.04E-04	3.76E-04	2.65E-04	1.96E-04	1.34E-04
6.4	Fugitive	1.51E-02	1.98E-04	1.78E-05	1.70E-05	1.50E-05	1.12E-05	7.90E-06	5.83E-06	3.99E-06

Label	Source Type	Average Air Concentration ($\mu\text{g}/\text{m}^3$)		ADR – Modeled Air ($\text{mg}/\text{kg}/\text{d}$)						
		Daily	Annual	Infant	Young Toddler	Toddler	Small Child	Child	Teen	Adult
6.5	Stack	1.62E-02	3.37E-05	1.90E-05	1.82E-05	1.61E-05	1.20E-05	8.45E-06	6.24E-06	4.27E-06
6.6	Stack	5.93E-04	3.40E-05	6.97E-07	6.66E-07	5.89E-07	4.40E-07	3.10E-07	2.29E-07	1.56E-07
6.7	Stack	7.20E-02	1.50E-04	8.46E-05	8.08E-05	7.15E-05	5.34E-05	3.76E-05	2.78E-05	1.90E-05
6.8	Stack	2.64E-03	1.51E-04	3.10E-06	2.96E-06	2.62E-06	1.96E-06	1.38E-06	1.02E-06	6.96E-07
6.9	Incineration	1.25E-01	2.57E-03	1.47E-04	1.40E-04	1.24E-04	9.25E-05	6.51E-05	4.81E-05	3.29E-05
6.10	Incineration	3.29E-03	2.57E-03	3.87E-06	3.70E-06	3.27E-06	2.44E-06	1.72E-06	1.27E-06	8.68E-07
6.11	Incineration	3.13E-01	6.44E-03	3.68E-04	3.51E-04	3.11E-04	2.32E-04	1.63E-04	1.21E-04	8.26E-05
6.12	Incineration	8.26E-03	6.45E-03	9.71E-06	9.28E-06	8.20E-06	6.13E-06	4.31E-06	3.19E-06	2.18E-06
8.1	Fugitive	8.97E-04	1.64E-08	1.05E-06	1.01E-06	8.91E-07	6.66E-07	4.68E-07	3.46E-07	2.37E-07
8.2	Fugitive	8.93E-02	5.78E-06	1.05E-04	1.00E-04	8.87E-05	6.63E-05	4.66E-05	3.44E-05	2.36E-05
8.3	Incineration	1.25E-03	9.47E-07	1.47E-06	1.40E-06	1.24E-06	9.28E-07	6.53E-07	4.82E-07	3.30E-07
8.4	Incineration	6.60E-02	1.88E-04	7.76E-05	7.41E-05	6.55E-05	4.90E-05	3.45E-05	2.54E-05	1.74E-05
9.1	Fugitive	7.98E-04	1.46E-08	9.38E-07	8.97E-07	7.93E-07	5.92E-07	4.17E-07	3.08E-07	2.11E-07
9.2	Fugitive	7.12E-01	1.30E-05	8.37E-04	7.99E-04	7.07E-04	5.28E-04	3.72E-04	2.75E-04	1.88E-04
10.1	Fugitive	3.35E-02	6.11E-07	3.94E-05	3.76E-05	3.32E-05	2.48E-05	1.75E-05	1.29E-05	8.83E-06
10.2	Fugitive	1.38E-04	6.14E-07	1.62E-07	1.55E-07	1.37E-07	1.02E-07	7.20E-08	5.32E-08	3.64E-08
10.3	Fugitive	1.67E-01	3.06E-06	1.97E-04	1.88E-04	1.66E-04	1.24E-04	8.74E-05	6.46E-05	4.42E-05
10.4	Fugitive	6.89E-04	3.07E-06	8.10E-07	7.74E-07	6.84E-07	5.11E-07	3.60E-07	2.66E-07	1.82E-07
10.5	Stack	4.23E-03	4.67E-07	4.97E-06	4.75E-06	4.20E-06	3.14E-06	2.21E-06	1.63E-06	1.12E-06
10.6	Stack	2.21E-05	4.68E-07	2.60E-08	2.49E-08	2.20E-08	1.64E-08	1.16E-08	8.54E-09	5.84E-09
10.7	Stack	2.12E-02	2.33E-06	2.49E-05	2.37E-05	2.10E-05	1.57E-05	1.10E-05	8.16E-06	5.58E-06
10.8	Stack	1.11E-04	2.34E-06	1.30E-07	1.24E-07	1.10E-07	8.22E-08	5.78E-08	4.27E-08	2.92E-08
10.9	Incineration	4.96E-03	3.75E-06	5.82E-06	5.57E-06	4.92E-06	3.68E-06	2.59E-06	1.91E-06	1.31E-06
10.10	Incineration	1.47E-05	3.76E-06	1.72E-08	1.65E-08	1.46E-08	1.09E-08	7.66E-09	5.66E-09	3.87E-09
10.11	Incineration	5.90E-03	4.47E-06	6.93E-06	6.63E-06	5.86E-06	4.38E-06	3.08E-06	2.28E-06	1.56E-06
10.12	Incineration	1.75E-05	4.47E-06	2.05E-08	1.96E-08	1.73E-08	1.29E-08	9.11E-09	6.73E-09	4.60E-09
11.1	Fugitive	3.10E-02	6.71E-06	3.64E-05	3.48E-05	3.08E-05	2.30E-05	1.62E-05	1.20E-05	8.18E-06
11.2	Fugitive	2.93E-04	6.60E-06	3.45E-07	3.29E-07	2.91E-07	2.18E-07	1.53E-07	1.13E-07	7.73E-08
11.3	Stack	1.63E-01	7.62E-05	1.92E-04	1.83E-04	1.62E-04	1.21E-04	8.52E-05	6.29E-05	4.30E-05
11.4	Stack	1.92E-03	7.54E-05	2.26E-06	2.16E-06	1.91E-06	1.43E-06	1.00E-06	7.41E-07	5.07E-07
12.1	Incineration	1.22E-03	5.06E-06	1.44E-06	1.37E-06	1.21E-06	9.07E-07	6.38E-07	4.71E-07	3.22E-07
12.2	Incineration	6.49E-06	5.07E-06	7.63E-09	7.29E-09	6.45E-09	4.82E-09	3.39E-09	2.50E-09	1.71E-09
12.3	Incineration	1.09E-03	4.50E-06	1.28E-06	1.22E-06	1.08E-06	8.06E-07	5.67E-07	4.19E-07	2.87E-07
12.4	Incineration	5.77E-06	4.50E-06	6.78E-09	6.48E-09	5.73E-09	4.28E-09	3.01E-09	2.23E-09	1.52E-09

Table_Apx G-23. Highly Exposed Average Daily Dose ($\text{mg}/\text{kg}/\text{day}$) for Modeled Air Only

Label	Source Type	Average Air Concentration ($\mu\text{g}/\text{m}^3$)		ADD – Modeled Air ($\text{mg}/\text{kg}/\text{d}$)							
		Daily	Annual	Infant	Young Toddler	Toddler	Small Child	Child	Teen	Adult - CT	Adult - HE
1.1	Fugitive	1.17E+00	8.74E-04	6.03E-07	6.13E-07	5.64E-07	4.75E-07	3.30E-07	2.34E-07	3.79E-08	1.04E-07
1.2	Fugitive	6.72E-02	8.82E-04	6.08E-07	6.19E-07	5.69E-07	4.79E-07	3.33E-07	2.36E-07	3.82E-08	1.05E-07

Label	Source Type	Average Air Concentration (µg/m ³)		ADD – Modeled Air (mg/kg/d)							
		Daily	Annual	Infant	Young Toddler	Toddler	Small Child	Child	Teen	Adult - CT	Adult - HE
1.3	Fugitive	5.85E+00	4.37E-03	3.01E-06	3.07E-06	2.82E-06	2.37E-06	1.65E-06	1.17E-06	1.89E-07	5.21E-07
1.4	Fugitive	3.36E-01	4.41E-03	3.04E-06	3.09E-06	2.84E-06	2.39E-06	1.66E-06	1.18E-06	1.91E-07	5.25E-07
1.5	Stack	1.71E-01	6.67E-04	4.60E-07	4.68E-07	4.30E-07	3.62E-07	2.52E-07	1.78E-07	2.89E-08	7.95E-08
1.6	Stack	1.17E-02	6.72E-04	4.63E-07	4.71E-07	4.33E-07	3.65E-07	2.53E-07	1.80E-07	2.91E-08	8.00E-08
1.7	Stack	8.54E-01	3.33E-03	2.30E-06	2.34E-06	2.15E-06	1.81E-06	1.26E-06	8.92E-07	1.44E-07	3.97E-07
1.8	Stack	5.86E-02	3.36E-03	2.32E-06	2.36E-06	2.17E-06	1.82E-06	1.27E-06	8.99E-07	1.46E-07	4.00E-07
1.9	Incineration	6.31E-03	2.56E-04	1.76E-07	1.79E-07	1.65E-07	1.39E-07	9.64E-08	6.84E-08	1.11E-08	3.04E-08
1.10	Incineration	3.28E-04	2.56E-04	1.76E-07	1.79E-07	1.65E-07	1.39E-07	9.65E-08	6.84E-08	1.11E-08	3.05E-08
1.11	Incineration	3.16E-02	1.28E-03	8.81E-07	8.97E-07	8.24E-07	6.94E-07	4.82E-07	3.42E-07	5.54E-08	1.52E-07
1.12	Incineration	1.64E-03	1.28E-03	8.81E-07	8.97E-07	8.24E-07	6.94E-07	4.82E-07	3.42E-07	5.54E-08	1.52E-07
2.1	Fugitive	2.21E-02	5.35E-06	3.69E-09	3.75E-09	3.45E-09	2.90E-09	2.02E-09	1.43E-09	2.32E-10	6.37E-10
2.2	Fugitive	3.43E-03	5.35E-06	3.69E-09	3.75E-09	3.45E-09	2.90E-09	2.02E-09	1.43E-09	2.32E-10	6.37E-10
2.3	Fugitive	2.64E-02	6.39E-06	4.41E-09	4.48E-09	4.12E-09	3.47E-09	2.41E-09	1.71E-09	2.77E-10	7.61E-10
2.4	Fugitive	4.10E-03	6.39E-06	4.40E-09	4.48E-09	4.12E-09	3.47E-09	2.41E-09	1.71E-09	2.77E-10	7.61E-10
2.5	Stack	3.18E-03	4.08E-06	2.81E-09	2.86E-09	2.63E-09	2.22E-09	1.54E-09	1.09E-09	1.77E-10	4.86E-10
2.6	Stack	4.90E-04	4.09E-06	2.82E-09	2.87E-09	2.64E-09	2.22E-09	1.54E-09	1.09E-09	1.77E-10	4.87E-10
2.7	Stack	3.80E-03	4.87E-06	3.36E-09	3.42E-09	3.14E-09	2.65E-09	1.84E-09	1.30E-09	2.11E-10	5.81E-10
2.8	Stack	5.85E-04	4.88E-06	3.37E-09	3.43E-09	3.15E-09	2.65E-09	1.84E-09	1.31E-09	2.12E-10	5.82E-10
3.1	Fugitive	2.77E+00	5.05E-05	3.49E-08	3.55E-08	3.26E-08	2.74E-08	1.91E-08	1.35E-08	2.19E-09	6.02E-09
3.2	Fugitive	1.30E-01	5.06E-05	3.49E-08	3.55E-08	3.26E-08	2.75E-08	1.91E-08	1.35E-08	2.19E-09	6.03E-09
3.3	Stack	3.50E-01	3.86E-05	2.66E-08	2.71E-08	2.49E-08	2.09E-08	1.46E-08	1.03E-08	1.67E-09	4.60E-09
3.4	Stack	1.85E-02	3.86E-05	2.66E-08	2.71E-08	2.49E-08	2.09E-08	1.46E-08	1.03E-08	1.67E-09	4.60E-09
4.1	Fugitive	3.49E-01	6.36E-06	4.39E-09	4.47E-09	4.10E-09	3.46E-09	2.40E-09	1.70E-09	2.76E-10	7.58E-10
4.2	Fugitive	1.64E-02	6.37E-06	4.39E-09	4.47E-09	4.11E-09	3.46E-09	2.40E-09	1.70E-09	2.76E-10	7.59E-10
4.3	Stack	4.40E-02	4.86E-06	3.35E-09	3.41E-09	3.13E-09	2.64E-09	1.83E-09	1.30E-09	2.10E-10	5.79E-10
4.4	Stack	2.33E-03	4.86E-06	3.35E-09	3.41E-09	3.13E-09	2.64E-09	1.83E-09	1.30E-09	2.10E-10	5.79E-10
4.5	Stack	1.89E-01	2.52E-05	1.74E-08	1.77E-08	1.62E-08	1.37E-08	9.49E-09	6.73E-09	1.09E-09	3.00E-09
4.6	Stack	1.09E-02	2.51E-05	1.73E-08	1.76E-08	1.62E-08	1.36E-08	9.48E-09	6.72E-09	1.09E-09	2.99E-09
4.7	Incineration	1.61E-01	1.89E-04	1.30E-07	1.32E-07	1.22E-07	1.02E-07	7.12E-08	5.05E-08	8.17E-09	2.25E-08
4.8	Incineration	6.84E-03	1.89E-04	1.30E-07	1.33E-07	1.22E-07	1.03E-07	7.14E-08	5.06E-08	8.19E-09	2.25E-08
4.9	Stack	2.90E+00	3.46E-04	2.39E-07	2.43E-07	2.23E-07	1.88E-07	1.31E-07	9.26E-08	1.50E-08	4.12E-08
4.10	Stack	1.43E-01	3.46E-04	2.38E-07	2.43E-07	2.23E-07	1.88E-07	1.30E-07	9.25E-08	1.50E-08	4.12E-08
4.11	Incineration	2.30E-01	1.78E-04	1.23E-07	1.25E-07	1.15E-07	9.68E-08	6.73E-08	4.77E-08	7.72E-09	2.12E-08
4.12	Incineration	7.14E-03	1.79E-04	1.23E-07	1.26E-07	1.15E-07	9.72E-08	6.75E-08	4.79E-08	7.75E-09	2.13E-08
5.1	Stack	3.20E-01	6.67E-04	4.60E-07	4.68E-07	4.30E-07	3.62E-07	2.52E-07	1.78E-07	2.89E-08	7.94E-08
5.2	Stack	3.16E-02	6.69E-04	4.61E-07	4.70E-07	4.32E-07	3.63E-07	2.52E-07	1.79E-07	2.90E-08	7.97E-08
5.3	Stack	1.60E+00	3.33E-03	2.30E-06	2.34E-06	2.15E-06	1.81E-06	1.26E-06	8.92E-07	1.44E-07	3.97E-07
5.4	Stack	1.58E-01	3.35E-03	2.31E-06	2.35E-06	2.16E-06	1.82E-06	1.26E-06	8.95E-07	1.45E-07	3.99E-07
5.5	Fugitive	2.25E+00	8.74E-04	6.03E-07	6.13E-07	5.64E-07	4.75E-07	3.30E-07	2.34E-07	3.79E-08	1.04E-07
5.6	Fugitive	1.97E-01	8.77E-04	6.04E-07	6.15E-07	5.65E-07	4.76E-07	3.31E-07	2.35E-07	3.80E-08	1.04E-07
5.7	Fugitive	1.13E+01	4.37E-03	3.01E-06	3.07E-06	2.82E-06	2.37E-06	1.65E-06	1.17E-06	1.89E-07	5.21E-07

Label	Source Type	Average Air Concentration (µg/m ³)		ADD – Modeled Air (mg/kg/d)							
		Daily	Annual	Infant	Young Toddler	Toddler	Small Child	Child	Teen	Adult - CT	Adult - HE
5.8	Fugitive	9.85E-01	4.38E-03	3.02E-06	3.08E-06	2.83E-06	2.38E-06	1.65E-06	1.17E-06	1.90E-07	5.22E-07
5.9	Incineration	2.61E-01	5.36E-03	3.70E-06	3.76E-06	3.46E-06	2.91E-06	2.02E-06	1.44E-06	2.32E-07	6.39E-07
5.10	Incineration	2.09E-02	5.37E-03	3.70E-06	3.77E-06	3.46E-06	2.91E-06	2.03E-06	1.44E-06	2.33E-07	6.40E-07
5.11	Incineration	4.96E-01	1.02E-02	7.05E-06	7.17E-06	6.59E-06	5.55E-06	3.86E-06	2.73E-06	4.43E-07	1.22E-06
5.12	Incineration	3.99E-02	1.02E-02	7.05E-06	7.17E-06	6.59E-06	5.55E-06	3.86E-06	2.74E-06	4.43E-07	1.22E-06
6.1	Fugitive	1.14E-01	4.42E-05	3.05E-08	3.10E-08	2.85E-08	2.40E-08	1.67E-08	1.18E-08	1.91E-09	5.27E-09
6.2	Fugitive	3.40E-03	4.46E-05	3.07E-08	3.13E-08	2.87E-08	2.42E-08	1.68E-08	1.19E-08	1.93E-09	5.31E-09
6.3	Fugitive	5.07E-01	1.97E-04	1.36E-07	1.38E-07	1.27E-07	1.07E-07	7.42E-08	5.26E-08	8.52E-09	2.34E-08
6.4	Fugitive	1.51E-02	1.98E-04	1.37E-07	1.39E-07	1.28E-07	1.08E-07	7.48E-08	5.31E-08	8.59E-09	2.36E-08
6.5	Stack	1.62E-02	3.37E-05	2.32E-08	2.37E-08	2.17E-08	1.83E-08	1.27E-08	9.02E-09	1.46E-09	4.02E-09
6.6	Stack	5.93E-04	3.40E-05	2.34E-08	2.38E-08	2.19E-08	1.84E-08	1.28E-08	9.09E-09	1.47E-09	4.05E-09
6.7	Stack	7.20E-02	1.50E-04	1.03E-07	1.05E-07	9.67E-08	8.14E-08	5.66E-08	4.01E-08	6.50E-09	1.79E-08
6.8	Stack	2.64E-03	1.51E-04	1.04E-07	1.06E-07	9.75E-08	8.21E-08	5.70E-08	4.04E-08	6.55E-09	1.80E-08
6.9	Incineration	1.25E-01	2.57E-03	1.77E-06	1.80E-06	1.66E-06	1.39E-06	9.69E-07	6.87E-07	1.11E-07	3.06E-07
6.10	Incineration	3.29E-03	2.57E-03	1.77E-06	1.80E-06	1.66E-06	1.39E-06	9.69E-07	6.87E-07	1.11E-07	3.06E-07
6.11	Incineration	3.13E-01	6.44E-03	4.44E-06	4.52E-06	4.16E-06	3.50E-06	2.43E-06	1.72E-06	2.79E-07	7.68E-07
6.12	Incineration	8.26E-03	6.45E-03	4.45E-06	4.52E-06	4.16E-06	3.50E-06	2.43E-06	1.73E-06	2.79E-07	7.68E-07
8.1	Fugitive	8.97E-04	1.64E-08	1.13E-11	1.15E-11	1.06E-11	8.89E-12	6.18E-12	4.38E-12	7.10E-13	1.95E-12
8.2	Fugitive	8.93E-02	5.78E-06	3.99E-09	4.06E-09	3.73E-09	3.14E-09	2.18E-09	1.55E-09	2.51E-10	6.89E-10
8.3	Incineration	1.25E-03	9.47E-07	6.53E-10	6.65E-10	6.11E-10	5.14E-10	3.57E-10	2.53E-10	4.10E-11	1.13E-10
8.4	Incineration	6.60E-02	1.88E-04	1.29E-07	1.32E-07	1.21E-07	1.02E-07	7.09E-08	5.02E-08	8.14E-09	2.24E-08
9.1	Fugitive	7.98E-04	1.46E-08	1.01E-11	1.02E-11	9.40E-12	7.91E-12	5.50E-12	3.90E-12	6.32E-13	1.74E-12
9.2	Fugitive	7.12E-01	1.30E-05	8.96E-09	9.12E-09	8.38E-09	7.06E-09	4.90E-09	3.48E-09	5.63E-10	1.55E-09
10.1	Fugitive	3.35E-02	6.11E-07	4.22E-10	4.29E-10	3.94E-10	3.32E-10	2.31E-10	1.64E-10	2.65E-11	7.28E-11
10.2	Fugitive	1.38E-04	6.14E-07	4.23E-10	4.31E-10	3.96E-10	3.33E-10	2.32E-10	1.64E-10	2.66E-11	7.31E-11
10.3	Fugitive	1.67E-01	3.06E-06	2.11E-09	2.14E-09	1.97E-09	1.66E-09	1.15E-09	8.18E-10	1.32E-10	3.64E-10
10.4	Fugitive	6.89E-04	3.07E-06	2.12E-09	2.15E-09	1.98E-09	1.67E-09	1.16E-09	8.21E-10	1.33E-10	3.66E-10
10.5	Stack	4.23E-03	4.67E-07	3.22E-10	3.27E-10	3.01E-10	2.53E-10	1.76E-10	1.25E-10	2.02E-11	5.56E-11
10.6	Stack	2.21E-05	4.68E-07	3.23E-10	3.29E-10	3.02E-10	2.54E-10	1.77E-10	1.25E-10	2.03E-11	5.58E-11
10.7	Stack	2.12E-02	2.33E-06	1.61E-09	1.64E-09	1.50E-09	1.27E-09	8.80E-10	6.24E-10	1.01E-10	2.78E-10
10.8	Stack	1.11E-04	2.34E-06	1.62E-09	1.64E-09	1.51E-09	1.27E-09	8.84E-10	6.27E-10	1.01E-10	2.79E-10
10.9	Incineration	4.96E-03	3.75E-06	2.59E-09	2.63E-09	2.42E-09	2.04E-09	1.42E-09	1.00E-09	1.63E-10	4.47E-10
10.10	Incineration	1.47E-05	3.76E-06	2.59E-09	2.64E-09	2.43E-09	2.04E-09	1.42E-09	1.01E-09	1.63E-10	4.48E-10
10.11	Incineration	5.90E-03	4.47E-06	3.08E-09	3.14E-09	2.88E-09	2.43E-09	1.69E-09	1.20E-09	1.94E-10	5.33E-10
10.12	Incineration	1.75E-05	4.47E-06	3.08E-09	3.14E-09	2.88E-09	2.43E-09	1.69E-09	1.20E-09	1.94E-10	5.33E-10
11.1	Fugitive	3.10E-02	6.71E-06	4.63E-09	4.71E-09	4.33E-09	3.64E-09	2.53E-09	1.80E-09	2.91E-10	8.00E-10
11.2	Fugitive	2.93E-04	6.60E-06	4.55E-09	4.63E-09	4.26E-09	3.59E-09	2.49E-09	1.77E-09	2.86E-10	7.87E-10
11.3	Stack	1.63E-01	7.62E-05	5.25E-08	5.34E-08	4.91E-08	4.14E-08	2.87E-08	2.04E-08	3.30E-09	9.08E-09
11.4	Stack	1.92E-03	7.54E-05	5.20E-08	5.29E-08	4.87E-08	4.10E-08	2.85E-08	2.02E-08	3.27E-09	8.99E-09
12.1	Incineration	1.22E-03	5.06E-06	3.49E-09	3.55E-09	3.27E-09	2.75E-09	1.91E-09	1.35E-09	2.19E-10	6.03E-10
12.2	Incineration	6.49E-06	5.07E-06	3.49E-09	3.56E-09	3.27E-09	2.75E-09	1.91E-09	1.36E-09	2.20E-10	6.04E-10

Label	Source Type	Average Air Concentration (µg/m ³)		ADD – Modeled Air (mg/kg/d)							
		Daily	Annual	Infant	Young Toddler	Toddler	Small Child	Child	Teen	Adult - CT	Adult - HE
12.3	Incineration	1.09E-03	4.50E-06	3.10E-09	3.16E-09	2.90E-09	2.44E-09	1.70E-09	1.20E-09	1.95E-10	5.36E-10
12.4	Incineration	5.77E-06	4.50E-06	3.11E-09	3.16E-09	2.90E-09	2.45E-09	1.70E-09	1.21E-09	1.95E-10	5.37E-10

Table_Apx G-24. Highly Exposed Aggregate Acute Dose Rate (mg/kg/day) for Modeled Air and Non-Air and Background

Label	Source Type	ADR – Modeled Air and Non-Air Background (mg/kg/d)						
		Infant	Young Toddler	Toddler	Small Child	Child	Teen	Adult
1.1	Fugitive	1.41E-03	1.34E-03	1.18E-03	8.81E-04	6.19E-04	4.55E-04	3.11E-04
1.2	Fugitive	1.18E-04	1.04E-04	8.44E-05	6.29E-05	4.33E-05	3.00E-05	2.06E-05
1.3	Fugitive	6.91E-03	6.59E-03	5.82E-03	4.35E-03	3.06E-03	2.26E-03	1.55E-03
1.4	Fugitive	4.34E-04	4.06E-04	3.51E-04	2.62E-04	1.84E-04	1.34E-04	9.16E-05
1.5	Stack	2.40E-04	2.20E-04	1.87E-04	1.40E-04	9.74E-05	7.00E-05	4.80E-05
1.6	Stack	5.31E-05	4.18E-05	2.93E-05	2.17E-05	1.43E-05	8.63E-06	6.01E-06
1.7	Stack	1.04E-03	9.87E-04	8.65E-04	6.47E-04	4.54E-04	3.33E-04	2.28E-04
1.8	Stack	1.08E-04	9.45E-05	7.58E-05	5.65E-05	3.88E-05	2.67E-05	1.84E-05
1.9	Incineration	4.67E-05	3.57E-05	2.39E-05	1.77E-05	1.15E-05	6.54E-06	4.58E-06
1.10	Incineration	3.97E-05	2.90E-05	1.80E-05	1.32E-05	8.38E-06	4.24E-06	3.00E-06
1.11	Incineration	7.64E-05	6.41E-05	4.90E-05	3.64E-05	2.47E-05	1.63E-05	1.12E-05
1.12	Incineration	4.12E-05	3.05E-05	1.93E-05	1.42E-05	9.07E-06	4.74E-06	3.35E-06
2.1	Fugitive	6.52E-05	5.34E-05	3.95E-05	2.94E-05	1.97E-05	1.26E-05	8.74E-06
2.2	Fugitive	4.33E-05	3.25E-05	2.10E-05	1.55E-05	1.00E-05	5.43E-06	3.82E-06
2.3	Fugitive	7.03E-05	5.82E-05	4.38E-05	3.26E-05	2.20E-05	1.43E-05	9.87E-06
2.4	Fugitive	4.41E-05	3.32E-05	2.17E-05	1.60E-05	1.04E-05	5.69E-06	4.00E-06
2.5	Stack	4.30E-05	3.22E-05	2.08E-05	1.54E-05	9.87E-06	5.34E-06	3.75E-06
2.6	Stack	3.99E-05	2.92E-05	1.81E-05	1.34E-05	8.47E-06	4.30E-06	3.04E-06
2.7	Stack	4.38E-05	3.29E-05	2.14E-05	1.58E-05	1.02E-05	5.58E-06	3.92E-06
2.8	Stack	4.00E-05	2.93E-05	1.82E-05	1.34E-05	8.52E-06	4.33E-06	3.07E-06
3.1	Fugitive	3.29E-03	3.14E-03	2.77E-03	2.07E-03	1.45E-03	1.07E-03	7.33E-04
3.2	Fugitive	1.93E-04	1.75E-04	1.47E-04	1.10E-04	7.63E-05	5.44E-05	3.73E-05
3.3	Stack	4.50E-04	4.21E-04	3.65E-04	2.72E-04	1.91E-04	1.39E-04	9.52E-05
3.4	Stack	6.11E-05	4.94E-05	3.60E-05	2.67E-05	1.79E-05	1.12E-05	7.80E-06
4.1	Fugitive	4.49E-04	4.20E-04	3.64E-04	2.72E-04	1.90E-04	1.39E-04	9.49E-05
4.2	Fugitive	5.86E-05	4.71E-05	3.39E-05	2.52E-05	1.68E-05	1.04E-05	7.25E-06
4.3	Stack	9.10E-05	7.81E-05	6.13E-05	4.57E-05	3.12E-05	2.11E-05	1.45E-05
4.4	Stack	4.20E-05	3.13E-05	1.99E-05	1.47E-05	9.43E-06	5.01E-06	3.53E-06
4.5	Stack	2.61E-04	2.41E-04	2.05E-04	1.53E-04	1.07E-04	7.69E-05	5.27E-05
4.6	Stack	5.21E-05	4.08E-05	2.84E-05	2.11E-05	1.39E-05	8.30E-06	5.78E-06
4.7	Incineration	2.29E-04	2.10E-04	1.78E-04	1.33E-04	9.25E-05	6.63E-05	4.55E-05
4.8	Incineration	4.73E-05	3.63E-05	2.44E-05	1.81E-05	1.18E-05	6.75E-06	4.72E-06
4.9	Stack	3.44E-03	3.28E-03	2.89E-03	2.16E-03	1.52E-03	1.12E-03	7.67E-04
4.10	Stack	2.08E-04	1.89E-04	1.60E-04	1.19E-04	8.30E-05	5.93E-05	4.07E-05

Label	Source Type	ADR – Modeled Air and Non-Air Background (mg/kg/d)						
		Infant	Young Toddler	Toddler	Small Child	Child	Teen	Adult
4.11	Incineration	3.09E-04	2.87E-04	2.46E-04	1.84E-04	1.28E-04	9.28E-05	6.36E-05
4.12	Incineration	4.77E-05	3.67E-05	2.47E-05	1.83E-05	1.19E-05	6.86E-06	4.80E-06
5.1	Stack	4.15E-04	3.88E-04	3.35E-04	2.50E-04	1.75E-04	1.27E-04	8.73E-05
5.2	Stack	7.65E-05	6.42E-05	4.90E-05	3.65E-05	2.47E-05	1.63E-05	1.13E-05
5.3	Stack	1.92E-03	1.83E-03	1.61E-03	1.20E-03	8.43E-04	6.21E-04	4.25E-04
5.4	Stack	2.25E-04	2.06E-04	1.75E-04	1.30E-04	9.08E-05	6.51E-05	4.46E-05
5.5	Fugitive	2.69E-03	2.56E-03	2.26E-03	1.69E-03	1.19E-03	8.73E-04	5.98E-04
5.6	Fugitive	2.71E-04	2.50E-04	2.13E-04	1.59E-04	1.11E-04	8.00E-05	5.49E-05
5.7	Fugitive	1.33E-02	1.27E-02	1.12E-02	8.38E-03	5.89E-03	4.35E-03	2.98E-03
5.8	Fugitive	1.20E-03	1.13E-03	9.95E-04	7.44E-04	5.22E-04	3.84E-04	2.63E-04
5.9	Incineration	3.45E-04	3.21E-04	2.76E-04	2.06E-04	1.44E-04	1.05E-04	7.16E-05
5.10	Incineration	6.39E-05	5.22E-05	3.84E-05	2.85E-05	1.91E-05	1.22E-05	8.44E-06
5.11	Incineration	6.22E-04	5.86E-04	5.10E-04	3.81E-04	2.67E-04	1.95E-04	1.34E-04
5.12	Incineration	8.62E-05	7.34E-05	5.72E-05	4.26E-05	2.90E-05	1.95E-05	1.34E-05
6.1	Fugitive	1.73E-04	1.57E-04	1.31E-04	9.76E-05	6.77E-05	4.81E-05	3.30E-05
6.2	Fugitive	4.33E-05	3.25E-05	2.10E-05	1.55E-05	9.99E-06	5.42E-06	3.81E-06
6.3	Fugitive	6.35E-04	5.98E-04	5.21E-04	3.89E-04	2.73E-04	2.00E-04	1.37E-04
6.4	Fugitive	5.71E-05	4.56E-05	3.26E-05	2.42E-05	1.61E-05	9.94E-06	6.90E-06
6.5	Stack	5.83E-05	4.68E-05	3.37E-05	2.50E-05	1.67E-05	1.03E-05	7.18E-06
6.6	Stack	4.00E-05	2.93E-05	1.82E-05	1.34E-05	8.52E-06	4.34E-06	3.07E-06
6.7	Stack	1.24E-04	1.09E-04	8.91E-05	6.64E-05	4.58E-05	3.19E-05	2.19E-05
6.8	Stack	4.24E-05	3.16E-05	2.03E-05	1.50E-05	9.59E-06	5.13E-06	3.61E-06
6.9	Incineration	1.86E-04	1.69E-04	1.41E-04	1.06E-04	7.33E-05	5.22E-05	3.58E-05
6.10	Incineration	4.32E-05	3.23E-05	2.09E-05	1.54E-05	9.93E-06	5.38E-06	3.78E-06
6.11	Incineration	4.07E-04	3.80E-04	3.28E-04	2.45E-04	1.72E-04	1.25E-04	8.55E-05
6.12	Incineration	4.90E-05	3.79E-05	2.58E-05	1.91E-05	1.25E-05	7.30E-06	5.09E-06
8.1	Fugitive	4.03E-05	2.97E-05	1.85E-05	1.37E-05	8.68E-06	4.46E-06	3.15E-06
8.2	Fugitive	1.44E-04	1.29E-04	1.06E-04	7.93E-05	5.48E-05	3.85E-05	2.65E-05
8.3	Incineration	4.08E-05	3.01E-05	1.89E-05	1.39E-05	8.86E-06	4.59E-06	3.24E-06
8.4	Incineration	1.17E-04	1.03E-04	8.32E-05	6.20E-05	4.27E-05	2.96E-05	2.03E-05
9.1	Fugitive	4.02E-05	2.95E-05	1.84E-05	1.36E-05	8.63E-06	4.42E-06	3.13E-06
9.2	Fugitive	8.76E-04	8.28E-04	7.24E-04	5.41E-04	3.80E-04	2.79E-04	1.91E-04
10.1	Fugitive	7.86E-05	6.63E-05	5.09E-05	3.79E-05	2.57E-05	1.70E-05	1.17E-05
10.2	Fugitive	3.95E-05	2.88E-05	1.78E-05	1.31E-05	8.28E-06	4.16E-06	2.95E-06
10.3	Fugitive	2.36E-04	2.17E-04	1.84E-04	1.37E-04	9.56E-05	6.87E-05	4.71E-05
10.4	Fugitive	4.01E-05	2.94E-05	1.83E-05	1.35E-05	8.57E-06	4.38E-06	3.10E-06
10.5	Stack	4.43E-05	3.34E-05	2.18E-05	1.61E-05	1.04E-05	5.74E-06	4.03E-06
10.6	Stack	3.93E-05	2.87E-05	1.77E-05	1.30E-05	8.22E-06	4.12E-06	2.92E-06
10.7	Stack	6.41E-05	5.24E-05	3.86E-05	2.87E-05	1.93E-05	1.23E-05	8.49E-06
10.8	Stack	3.94E-05	2.88E-05	1.77E-05	1.31E-05	8.27E-06	4.15E-06	2.94E-06
10.9	Incineration	4.51E-05	3.42E-05	2.26E-05	1.67E-05	1.08E-05	6.02E-06	4.22E-06
10.10	Incineration	3.93E-05	2.87E-05	1.76E-05	1.30E-05	8.22E-06	4.11E-06	2.92E-06

Label	Source Type	ADR – Modeled Air and Non-Air Background (mg/kg/d)						
		Infant	Young Toddler	Toddler	Small Child	Child	Teen	Adult
10.11	Incineration	4.62E-05	3.53E-05	2.35E-05	1.74E-05	1.13E-05	6.38E-06	4.47E-06
10.12	Incineration	3.93E-05	2.87E-05	1.76E-05	1.30E-05	8.22E-06	4.12E-06	2.92E-06
11.1	Fugitive	7.57E-05	6.35E-05	4.84E-05	3.60E-05	2.44E-05	1.61E-05	1.11E-05
11.2	Fugitive	3.96E-05	2.90E-05	1.79E-05	1.32E-05	8.36E-06	4.22E-06	2.99E-06
11.3	Stack	2.31E-04	2.12E-04	1.80E-04	1.34E-04	9.34E-05	6.70E-05	4.59E-05
11.4	Stack	4.16E-05	3.08E-05	1.95E-05	1.44E-05	9.21E-06	4.85E-06	3.42E-06
12.1	Incineration	4.07E-05	3.00E-05	1.88E-05	1.39E-05	8.85E-06	4.58E-06	3.24E-06
12.2	Incineration	3.93E-05	2.87E-05	1.76E-05	1.30E-05	8.21E-06	4.11E-06	2.92E-06
12.3	Incineration	4.06E-05	2.99E-05	1.87E-05	1.38E-05	8.78E-06	4.53E-06	3.20E-06
12.4	Incineration	3.93E-05	2.87E-05	1.76E-05	1.30E-05	8.21E-06	4.11E-06	2.92E-06

Table_Apx G-25. Highly Exposed Aggregate Average Daily Dose (mg/kg/day) for Modeled Air and Non-Air and Background

Label	Source Type	ADD – Modeled Air and Non-Air Background (mg/kg/d)						
		Infant	Young Toddler	Toddler	Small Child	Child	Teen	Adult
1.1	Fugitive	3.99E-05	2.93E-05	1.82E-05	1.35E-05	8.54E-06	4.34E-06	2.95E-06
1.2	Fugitive	3.99E-05	2.93E-05	1.82E-05	1.35E-05	8.54E-06	4.35E-06	2.95E-06
1.3	Fugitive	4.23E-05	3.17E-05	2.04E-05	1.54E-05	9.86E-06	5.28E-06	3.10E-06
1.4	Fugitive	4.23E-05	3.17E-05	2.05E-05	1.54E-05	9.87E-06	5.29E-06	3.11E-06
1.5	Stack	3.98E-05	2.91E-05	1.81E-05	1.34E-05	8.46E-06	4.29E-06	2.94E-06
1.6	Stack	3.98E-05	2.91E-05	1.81E-05	1.34E-05	8.46E-06	4.29E-06	2.94E-06
1.7	Stack	4.16E-05	3.10E-05	1.98E-05	1.48E-05	9.47E-06	5.00E-06	3.06E-06
1.8	Stack	4.16E-05	3.10E-05	1.98E-05	1.48E-05	9.48E-06	5.01E-06	3.06E-06
1.9	Incineration	3.95E-05	2.88E-05	1.78E-05	1.31E-05	8.31E-06	4.18E-06	2.93E-06
1.10	Incineration	3.95E-05	2.88E-05	1.78E-05	1.31E-05	8.31E-06	4.18E-06	2.93E-06
1.11	Incineration	4.02E-05	2.95E-05	1.85E-05	1.37E-05	8.69E-06	4.45E-06	2.97E-06
1.12	Incineration	4.02E-05	2.95E-05	1.85E-05	1.37E-05	8.69E-06	4.45E-06	2.97E-06
2.1	Fugitive	3.93E-05	2.86E-05	1.76E-05	1.30E-05	8.21E-06	4.11E-06	2.92E-06
2.2	Fugitive	3.93E-05	2.86E-05	1.76E-05	1.30E-05	8.21E-06	4.11E-06	2.92E-06
2.3	Fugitive	3.93E-05	2.87E-05	1.76E-05	1.30E-05	8.21E-06	4.11E-06	2.92E-06
2.4	Fugitive	3.93E-05	2.87E-05	1.76E-05	1.30E-05	8.21E-06	4.11E-06	2.92E-06
2.5	Stack	3.93E-05	2.86E-05	1.76E-05	1.30E-05	8.21E-06	4.11E-06	2.92E-06
2.6	Stack	3.93E-05	2.86E-05	1.76E-05	1.30E-05	8.21E-06	4.11E-06	2.92E-06
2.7	Stack	3.93E-05	2.86E-05	1.76E-05	1.30E-05	8.21E-06	4.11E-06	2.92E-06
2.8	Stack	3.93E-05	2.86E-05	1.76E-05	1.30E-05	8.21E-06	4.11E-06	2.92E-06
3.1	Fugitive	3.93E-05	2.87E-05	1.77E-05	1.30E-05	8.23E-06	4.12E-06	2.92E-06
3.2	Fugitive	3.93E-05	2.87E-05	1.77E-05	1.30E-05	8.23E-06	4.12E-06	2.92E-06
3.3	Stack	3.93E-05	2.87E-05	1.77E-05	1.30E-05	8.23E-06	4.12E-06	2.92E-06
3.4	Stack	3.93E-05	2.87E-05	1.77E-05	1.30E-05	8.23E-06	4.12E-06	2.92E-06
4.1	Fugitive	3.93E-05	2.87E-05	1.76E-05	1.30E-05	8.21E-06	4.11E-06	2.92E-06
4.2	Fugitive	3.93E-05	2.87E-05	1.76E-05	1.30E-05	8.21E-06	4.11E-06	2.92E-06
4.3	Stack	3.93E-05	2.86E-05	1.76E-05	1.30E-05	8.21E-06	4.11E-06	2.92E-06
4.4	Stack	3.93E-05	2.86E-05	1.76E-05	1.30E-05	8.21E-06	4.11E-06	2.92E-06
4.5	Stack	3.93E-05	2.87E-05	1.76E-05	1.30E-05	8.22E-06	4.12E-06	2.92E-06
4.6	Stack	3.93E-05	2.87E-05	1.76E-05	1.30E-05	8.22E-06	4.12E-06	2.92E-06
4.7	Incineration	3.94E-05	2.88E-05	1.78E-05	1.31E-05	8.28E-06	4.16E-06	2.92E-06
4.8	Incineration	3.94E-05	2.88E-05	1.78E-05	1.31E-05	8.28E-06	4.16E-06	2.92E-06
4.9	Stack	3.95E-05	2.89E-05	1.79E-05	1.32E-05	8.34E-06	4.20E-06	2.93E-06
4.10	Stack	3.95E-05	2.89E-05	1.79E-05	1.32E-05	8.34E-06	4.20E-06	2.93E-06
4.11	Incineration	3.94E-05	2.88E-05	1.77E-05	1.31E-05	8.28E-06	4.16E-06	2.92E-06
4.12	Incineration	3.94E-05	2.88E-05	1.77E-05	1.31E-05	8.28E-06	4.16E-06	2.92E-06
5.1	Stack	3.98E-05	2.91E-05	1.81E-05	1.34E-05	8.46E-06	4.29E-06	2.94E-06
5.2	Stack	3.98E-05	2.91E-05	1.81E-05	1.34E-05	8.46E-06	4.29E-06	2.94E-06
5.3	Stack	4.16E-05	3.10E-05	1.98E-05	1.48E-05	9.47E-06	5.00E-06	3.06E-06

Label	Source Type	ADD – Modeled Air and Non-Air Background (mg/kg/d)						
		Infant	Young Toddler	Toddler	Small Child	Child	Teen	Adult
5.4	Stack	4.16E-05	3.10E-05	1.98E-05	1.48E-05	9.47E-06	5.00E-06	3.06E-06
5.5	Fugitive	3.99E-05	2.93E-05	1.82E-05	1.35E-05	8.54E-06	4.34E-06	2.95E-06
5.6	Fugitive	3.99E-05	2.93E-05	1.82E-05	1.35E-05	8.54E-06	4.34E-06	2.95E-06
5.7	Fugitive	4.23E-05	3.17E-05	2.05E-05	1.54E-05	9.86E-06	5.28E-06	3.10E-06
5.8	Fugitive	4.23E-05	3.17E-05	2.05E-05	1.54E-05	9.87E-06	5.28E-06	3.10E-06
5.9	Incineration	4.30E-05	3.24E-05	2.11E-05	1.59E-05	1.02E-05	5.54E-06	3.15E-06
5.10	Incineration	4.30E-05	3.24E-05	2.11E-05	1.59E-05	1.02E-05	5.55E-06	3.15E-06
5.11	Incineration	4.63E-05	3.58E-05	2.42E-05	1.86E-05	1.21E-05	6.84E-06	3.36E-06
5.12	Incineration	4.63E-05	3.58E-05	2.42E-05	1.86E-05	1.21E-05	6.84E-06	3.36E-06
6.1	Fugitive	3.93E-05	2.87E-05	1.77E-05	1.30E-05	8.23E-06	4.12E-06	2.92E-06
6.2	Fugitive	3.93E-05	2.87E-05	1.77E-05	1.30E-05	8.23E-06	4.12E-06	2.92E-06
6.3	Fugitive	3.94E-05	2.88E-05	1.78E-05	1.31E-05	8.29E-06	4.16E-06	2.92E-06
6.4	Fugitive	3.94E-05	2.88E-05	1.78E-05	1.31E-05	8.29E-06	4.16E-06	2.92E-06
6.5	Stack	3.93E-05	2.87E-05	1.77E-05	1.30E-05	8.22E-06	4.12E-06	2.92E-06
6.6	Stack	3.93E-05	2.87E-05	1.77E-05	1.30E-05	8.22E-06	4.12E-06	2.92E-06
6.7	Stack	3.94E-05	2.88E-05	1.77E-05	1.31E-05	8.27E-06	4.15E-06	2.92E-06
6.8	Stack	3.94E-05	2.88E-05	1.77E-05	1.31E-05	8.27E-06	4.15E-06	2.92E-06
6.9	Incineration	4.11E-05	3.04E-05	1.93E-05	1.44E-05	9.18E-06	4.80E-06	3.03E-06
6.10	Incineration	4.11E-05	3.04E-05	1.93E-05	1.44E-05	9.18E-06	4.80E-06	3.03E-06
6.11	Incineration	4.37E-05	3.32E-05	2.18E-05	1.65E-05	1.06E-05	5.83E-06	3.19E-06
6.12	Incineration	4.37E-05	3.32E-05	2.18E-05	1.65E-05	1.06E-05	5.83E-06	3.19E-06
8.1	Fugitive	3.93E-05	2.86E-05	1.76E-05	1.30E-05	8.21E-06	4.11E-06	2.91E-06
8.2	Fugitive	3.93E-05	2.87E-05	1.76E-05	1.30E-05	8.21E-06	4.11E-06	2.92E-06
8.3	Incineration	3.93E-05	2.86E-05	1.76E-05	1.30E-05	8.21E-06	4.11E-06	2.91E-06
8.4	Incineration	3.94E-05	2.88E-05	1.78E-05	1.31E-05	8.28E-06	4.16E-06	2.92E-06
9.1	Fugitive	3.93E-05	2.86E-05	1.76E-05	1.30E-05	8.21E-06	4.11E-06	2.91E-06
9.2	Fugitive	3.93E-05	2.87E-05	1.76E-05	1.30E-05	8.22E-06	4.11E-06	2.92E-06
10.1	Fugitive	3.93E-05	2.86E-05	1.76E-05	1.30E-05	8.21E-06	4.11E-06	2.91E-06
10.2	Fugitive	3.93E-05	2.86E-05	1.76E-05	1.30E-05	8.21E-06	4.11E-06	2.91E-06
10.3	Fugitive	3.93E-05	2.86E-05	1.76E-05	1.30E-05	8.21E-06	4.11E-06	2.91E-06
10.4	Fugitive	3.93E-05	2.86E-05	1.76E-05	1.30E-05	8.21E-06	4.11E-06	2.91E-06
10.5	Stack	3.93E-05	2.86E-05	1.76E-05	1.30E-05	8.21E-06	4.11E-06	2.91E-06
10.6	Stack	3.93E-05	2.86E-05	1.76E-05	1.30E-05	8.21E-06	4.11E-06	2.91E-06
10.7	Stack	3.93E-05	2.86E-05	1.76E-05	1.30E-05	8.21E-06	4.11E-06	2.91E-06
10.8	Stack	3.93E-05	2.86E-05	1.76E-05	1.30E-05	8.21E-06	4.11E-06	2.91E-06
10.9	Incineration	3.93E-05	2.86E-05	1.76E-05	1.30E-05	8.21E-06	4.11E-06	2.92E-06
10.10	Incineration	3.93E-05	2.86E-05	1.76E-05	1.30E-05	8.21E-06	4.11E-06	2.92E-06
10.11	Incineration	3.93E-05	2.86E-05	1.76E-05	1.30E-05	8.21E-06	4.11E-06	2.92E-06
10.12	Incineration	3.93E-05	2.86E-05	1.76E-05	1.30E-05	8.21E-06	4.11E-06	2.92E-06
11.1	Fugitive	3.93E-05	2.87E-05	1.76E-05	1.30E-05	8.21E-06	4.11E-06	2.92E-06
11.2	Fugitive	3.93E-05	2.87E-05	1.76E-05	1.30E-05	8.21E-06	4.11E-06	2.92E-06
11.3	Stack	3.93E-05	2.87E-05	1.77E-05	1.30E-05	8.24E-06	4.13E-06	2.92E-06

Label	Source Type	ADD – Modeled Air and Non-Air Background (mg/kg/d)						
		Infant	Young Toddler	Toddler	Small Child	Child	Teen	Adult
11.4	Stack	3.93E-05	2.87E-05	1.77E-05	1.30E-05	8.24E-06	4.13E-06	2.92E-06
12.1	Incineration	3.93E-05	2.86E-05	1.76E-05	1.30E-05	8.21E-06	4.11E-06	2.92E-06
12.2	Incineration	3.93E-05	2.86E-05	1.76E-05	1.30E-05	8.21E-06	4.11E-06	2.92E-06
12.3	Incineration	3.93E-05	2.86E-05	1.76E-05	1.30E-05	8.21E-06	4.11E-06	2.92E-06
12.4	Incineration	3.93E-05	2.86E-05	1.76E-05	1.30E-05	8.21E-06	4.11E-06	2.92E-06

G.5 Scenarios C1 and C2: Consumer Exposure to XPS/EPS Insulation in Residences and Automobiles Calculations

G.5.1 General Mass Balance Equation Used in IECCU

EPA used the following general mass balance as defined in the user guide of the IECCU model to estimate the indoor concentrations of HBCD in indoor air and dust of a multi-zone indoor environment ([U.S. EPA 2019r](#)).

Equation_Apx G-3

$$V_i \frac{dC_i}{dt} = \sum_{j=1}^{n_1} A_j E_j - \sum_{k=0}^{n_2} Q_{ik} C_i + \sum_{k=0}^{n_3} Q_{ki} C_k - \sum_{m=1}^{n_4} S_m - \sum_{p=1}^{n_5} P_p - \sum_{q=1}^{n_6} D_q$$

where V_i is volume of zone i (m^3)

C_i is air concentration in zone i ($\mu g/m^3$)

t is elapsed time (h)

A_j is area of source j in zone i (m^2)

E_j is emission factor for source j in zone i ($\mu g/m^2/h$)

Q_{ik} is air flow from zone i to zone k , $i \neq k$ (m^3/h)

Q_{ki} is air flow from zone k to zone i , $k \neq i$ (m^3/h)

C_k is air concentration in zone k ($\mu g/m^3$)

S_m is sorption rate onto interior surface m in zone i ($\mu g/h$)

P_p is rate of sorption by airborne particulate matter p in zone i ($\mu g/h$)

D_q is rate of sorption by settled dust q in zone i ($\mu g/h$)

Subscripts j , k , l , m , p , and q are summation counters

n_1 through n_6 are item numbers for their respective summations.

Equation_Apx G-3 states that the change of the concentration in air in zone i is determined by six factors: (1) the emissions from the sources in the zone, (2) the rate of chemical removed from zone i by the ventilation and interzonal air flows (Q_{ik}), (3) the rate of chemical carried into zone i by the infiltration and interzonal air flows (Q_{ki}), (4) the rate of chemical sorption by interior surfaces, (5) the rate of chemical sorption by airborne particles, and (6) the rate of chemical sorption by settled dust. Given a set of initial conditions, **Equation_Apx G-3** can be solved numerically.

Equation_Apx G-3 does not include the term for chemical reactions because HBCD is chemically inert at normal temperatures. Also the air concentrations in **Equation_Apx G-3**, C_i and C_k can be used to represent either the gas-phase or particle-phase concentrations or both.

G.5.2 Typical Residential House

A three-zone configuration described by (Bevington et al. 2017) was used to represent a generic residential building, where the insulation is applied to both the attic and crawlspace. The baseline ventilation and interzonal air flows are shown in Figure_Apx G-1. The three-zone configuration for a generic residential setting and baseline ventilation and interzonal air flows. The ventilation rates for the three zones are shown in Figure_Apx G-1. In this work, EPA used the ventilation rates for the “vented” attic and crawlspace.

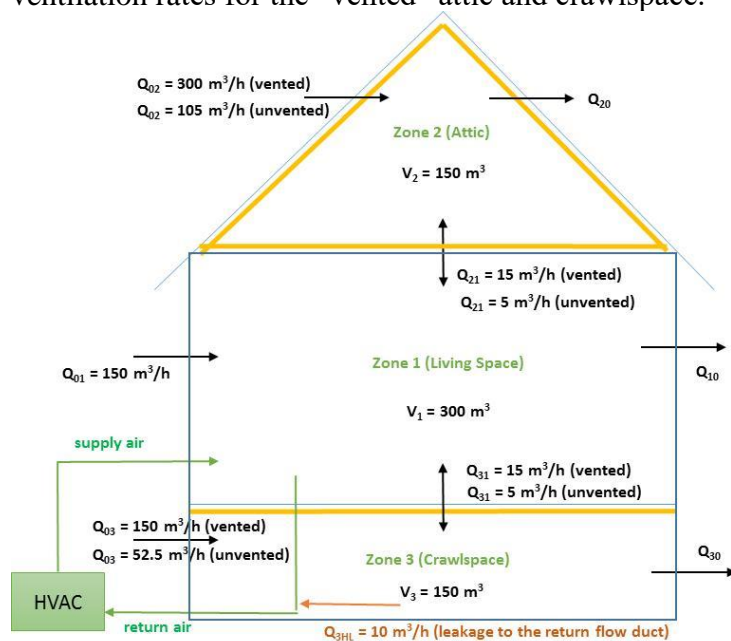

Figure_Apx G-1. The three-zone configuration for a generic residential setting and baseline ventilation and interzonal air flows.

Table_Apx G-26. Zone Names, Volumes, and Baseline Ventilation Rates

Zone name	Zone volume (m ³)	Ventilation rate (h ⁻¹)
Living space	300	0.5
Attic	150	2.0 (vented) 0.7 (unvented)
Crawlspace	150	1.0 (vented) 0.35 (unvented)

G.5.3 Typical Passenger Vehicle

EPA used 3.4 m³ as the typical interior volume of a small SUV (passenger volume plus cargo volume).

The in-vehicle ventilation rate can be drastically different depending on factors such as whether the vehicle is moving, how the AC operates, and vehicle type and age. A study by (Ott et al. 2008) shows that, with a vehicle moving, windows closed, and the ventilation system off (or the air conditioner set to AC Max), the air change rate was less than 6.6 h⁻¹ for speeds ranging from 20 to 72 mph (32 to 116 km/h).

In this work EPA assume the air change rate is 5 h⁻¹ for a moving vehicle with windows closed, and 0.5 h⁻¹ for a stationary vehicle with windows closed.

For a moving vehicle with the AC on, EPA assumes the temperature inside the cabin is constant and at 21 °C.

For a stationary vehicle, EPA assume its temperature is subject to diurnal fluctuation, as defined by the following parameters:

Daily average	20 °C
Daily fluctuation	±15 °C
Peak temperature occurrence	2:00 pm

G.5.4 Estimation of Key Parameters

Material/air partition coefficient (K)

EPA has been unable to find experimentally determined material/air partition coefficients for HBCD in insulation boards. In this evaluation, EPA estimated K from **Equation_Apx G-4** ([Guo 2002](#)):

Equation_Apx G-4

$$\ln K = 9.76 - 0.785 \ln P$$

where P is the vapor pressure, mm Hg.

The K values obtained from **Equation_Apx G-5** was then adjusted by the density of the foam material (Equation 3):

Equation_Apx G-5

$$K' = K \frac{\rho}{\rho_0}$$

where

K' is the partition coefficient for the foam board, dimensionless,

K is the partition coefficient for the neat polymer, dimensionless,

ρ is the density of the foam, g/cm³,

ρ_0 is the density of the neat polymer, g/cm³; $\rho_0 = 1.05$ for polystyrene polymer.

The temperature dependence of the partition coefficient was estimated by the method proposed by ([Tian et al. 2017](#)):

Equation_Apx G-6

$$\ln \frac{K_2}{K_1} = a \frac{\Delta H_v}{R} \left(\frac{1}{T_2} - \frac{1}{T_1} \right)$$

where

K_1, K_2 are partition coefficients at temperatures T_1 and T_2 (dimensionless),

a is the absolute value of the slope for the $\ln(K)$ - $\ln(P)$ relationship, where P is vapor pressure.

ΔH_v = vaporization enthalpy (J/mol),

T_1, T_2 = absolute temperature corresponding to K_1 and K_2 (K),

R = gas constant (J/mol/K).

Parameter a is reported to be between 0.753 and 1.05 for open-cell PU foam. In this work, EPA used $a = 0.9$ and $\Delta H_v = 8.14 \times 10^4$ J/mol ([Tian et al. 2017](#)).

- **Solid-phase diffusion coefficient (D)**

A QSAR model developed by ([Huang et al. 2017](#)) was used to estimate the solid-phase diffusion coefficient for the foam materials (**Equation_Apx G-7**):

Equation_Apx G-7

$$\log D = 6.39 - 2.49 \log m + b + \frac{\tau - 3486}{T}$$

where

m is the molecular weight of the chemical, g/mol,

b is an empirical constant that reflects the material type,

τ is an empirical constant that reflects the temperature effect,

T is temperature (K).

The values of b and τ for polystyrene foams — including both XPS and EPS — are -8.323 and 1676, respectively. The difference between XPS and EPS is discussed in the main Risk Evaluation document.

- **Aerosol/air partition coefficient (K_p)**

The aerosol/air partition coefficient was calculated from Equation F-8 ([Finizio et al. 1997](#)):

$$\log K_p = m \log K_{OA} + b \quad (\text{F-8})$$

where

m and b are constant for a given chemical,

K_{OA} is the octanol-air partition coefficient (dimensionless).

In this work, EPA used $K_{OA} = 2.92 \times 10^{10}$ for HBCD (from EPA's EPI Suite (<https://www.epa.gov/tsca-screening-tools/epi-suite-estimation-program-interface>)). The m and b values for generic organic compounds are $m = 0.55$, and $b = 8.23$ ([Finizio et al. 1997](#)). The resulting K_p is 3.36×10^9 for HBCD.

- **Dust/air partition coefficient (K_d)**

The dimensionless dust/air partition coefficient was estimated with the empirical model developed by ([Shoeib et al. 2005](#)):

$$K_d = 0.411 \rho f_{oc} K_{OA} \quad (\text{F-9})$$

where

ρ is the density of the dust, g/cm³,

f_{oc} is the organic carbon content in the dust, fraction,

K_{OA} is the octanol/air partition coefficient, dimensionless.

G.5.5 Model Parameters

HBCD sources – polystyrene foam boards

EPA assume that the source areas are 180 m² in the attic and 120 m² in the crawlspace ([Bevington et al. 2017](#)). Other parameters are summarized in Table_Apx G-27. Parameters for the HBCD sources.

Table_Apx G-27. Parameters for the HBCD sources.

Parameter	Value	Data source/method
Board thickness (cm)	10	FOAMULAR 400 specs
HBCD content	0.50%	(U.S. EPA 2014d)
Board density (kg/m ³)	28.9	FOAMULAR 400 specs
Partition coef. (K) at 21 °C	1.70×10^7	Guo (2002) ; adjusted by foam density
K as a function of temperature	Equation 9	Tian et al. (2017)
Diffusion coef. (D) at 21 °C (m ² /h)	3.20×10^{-12}	(Huang et al. 2017)
D as a function of temperature	Equation 10	(Huang et al. 2017)

The parameters EPA used to represent the HBCD sources in passenger vehicles are the same as those in Table_Apx G-27 except that the source area is 0.5 m² and that the HBCD content in the polymer is 2.5%.

- **HBCD sinks – gypsum board walls**

The indoor sinks in the living space are represented by the gypsum board walls. Parameters used are shown in Table_Apx G-28.

Table_Apx G-28. Parameters for the HBCD sinks.

Parameter	Value	Data source/method
Surface area (m ²)	800	Bevington et al. (2017)
Thickness (m)	0.01 (~3/8 inch)	Product specs
Partition coefficient (dimensionless)	5.88×10^8	Guo (2002)
Diffusion coefficient (m ² /h)	1.08×10^{-9}	(Huang et al. 2017)

- **Airborne PM**

For airborne particulate matter, EPA used the following parameters:

Particle size	2.5 μm
Mass concentration in ambient air	30 μg/m ³
Infiltration factor	0.8
Aerosol/air partition coefficient	3.36×10^9 (by the (Finizio et al. 1997) method)
Deposition rate constant	0.68 h ⁻¹ for the living area
0.60 for attic and crawlspace	

- **Settled dust**

The parameters EPA used to model settled dust are presented in Table_Apx G-29.

Table_Apx G-29. Parameters for Settled Dust

Parameter	Value	Data source/method
Average diameter (μm)	50	Bevington et al. (2017)
Dust loading (g/m^2)	10	Bevington et al. (2017)
Partition coefficient	2.90×10^9	Shoeib et al. (2005)
Diffusion coefficient (m^2/h)	1.0×10^{-13}	Estimated ^[1]

^[1] The reported diffusion coefficient values for aerosol particles vary significantly. The value EPA used is in the middle.

G.5.6 Simulation Results

- HBCD in a “typical” home

Simulation results are presented in Figure_Apx G-2 through Figure_Apx G-5. As shown in Figure_Apx G-4, the predicted HBCD content in house dust is in line with the measured values in the literature. Table_Apx G-30 presents the mass balance results at the 100 elapsed days.

The predicted emission rates (Figure_Apx G-5), sorption rates (Figure_Apx G-6) and the mass balance (Table_Apx G-30) were obtained with the new features recently added to IECCU.

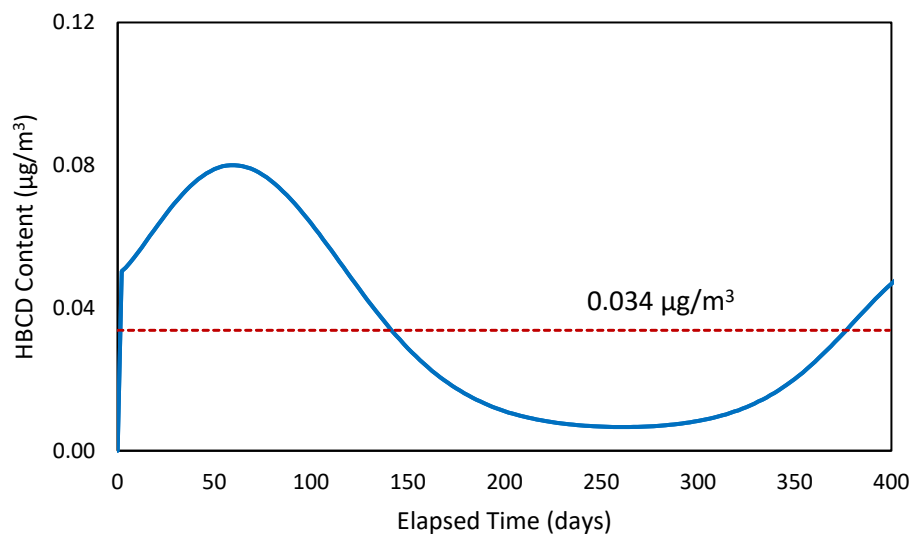

Figure_Apx G-2. Predicted Gas-phase HBCD Concentration in Living Area

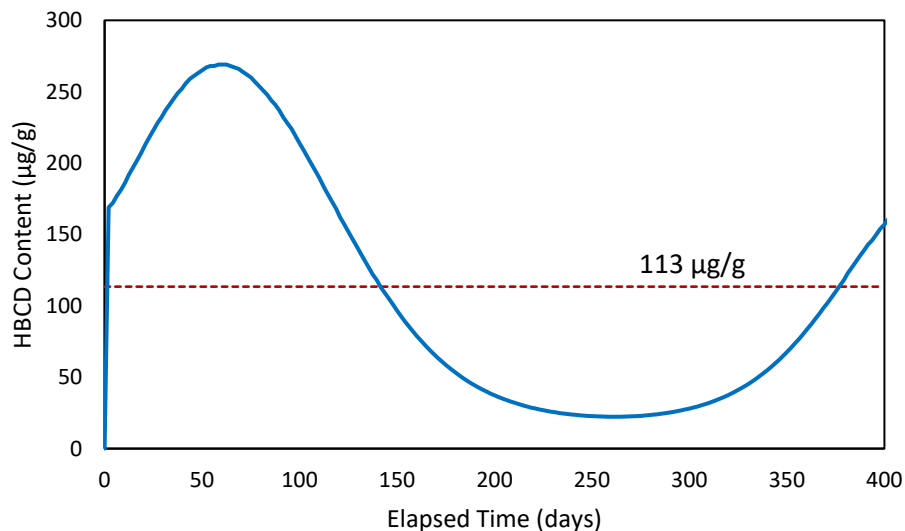

Figure_Apx G-3. Predicted HBCD Concentration in Airborne PM in Living Area

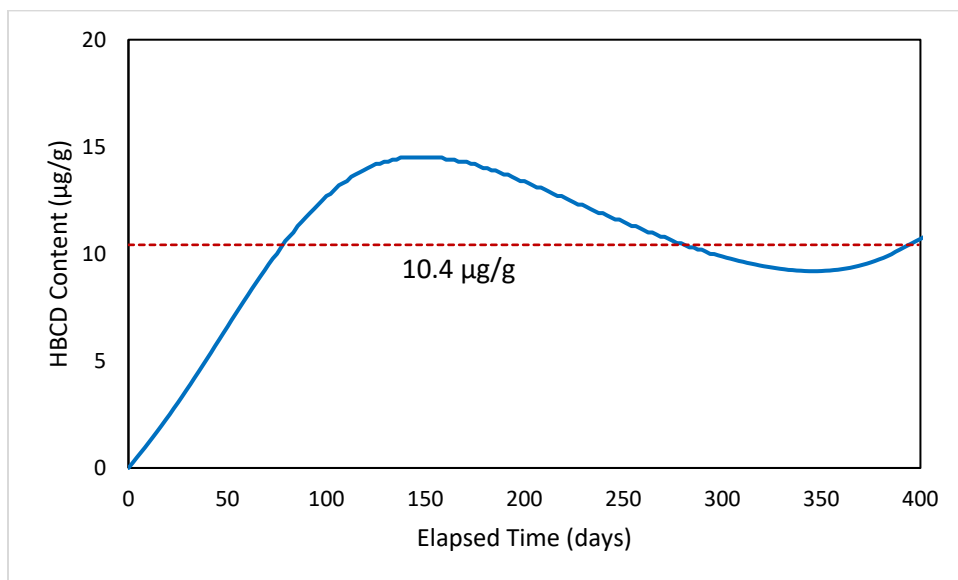

Figure_Apx G-4. Predicted HBCD Concentration in Settled Dust

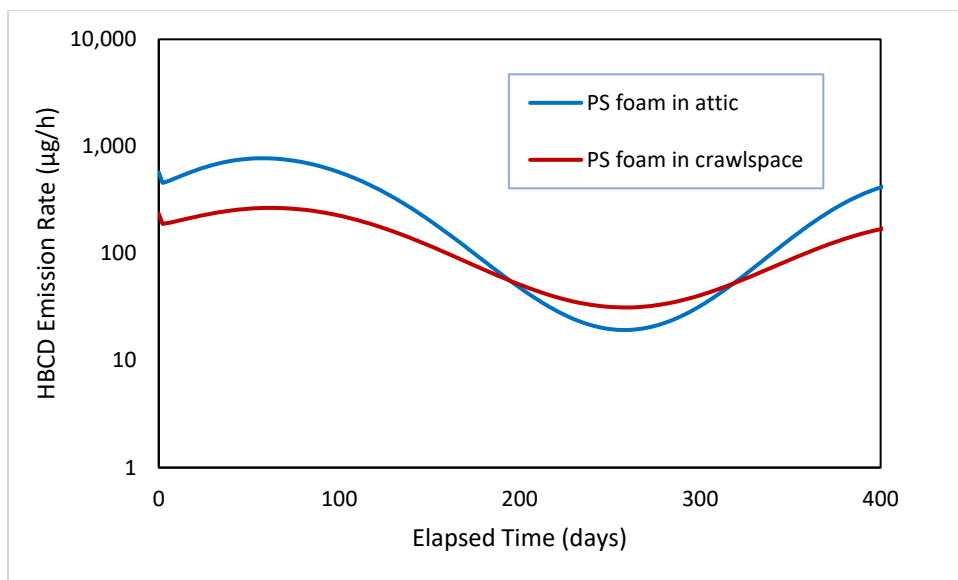

Figure_Apx G-5. Predicted HBCD Emission Rates from Polystyrene Foam Boards in Attic and Crawlspace

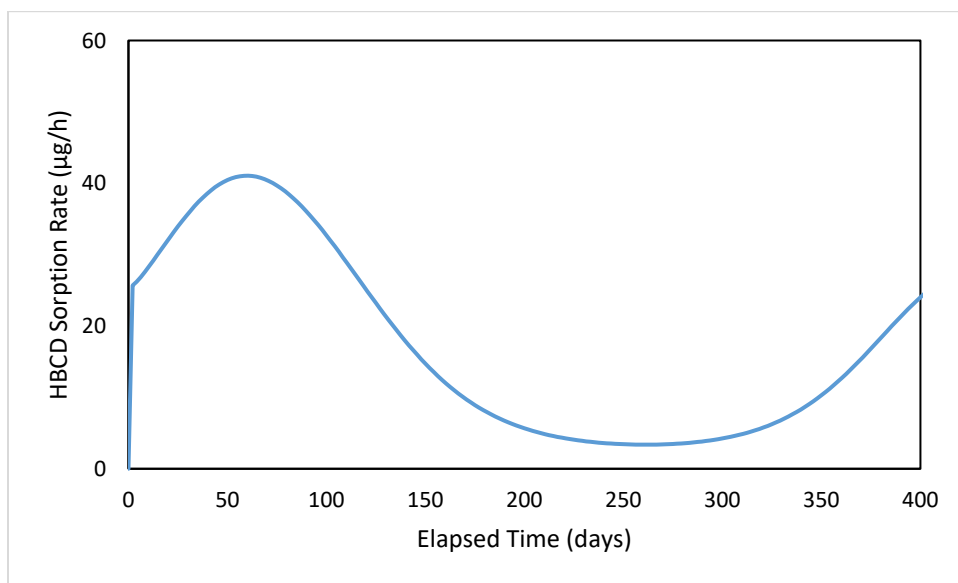

Figure_Apx G-6. Rate of HBCD Sorption by Gypsum Board Walls

Table_Apx G-30. Mass Balance Results for HBCD in the Simulated Home at 100 Elapsed Days

Emission/Fate		Mass (µg)	Percentage of of emitted
Total HBCD Emitted		2.2E+06	
HBCD Fate	Vented out	2.1E+06	94.3%
	Remaining in air	4.9E+02	0.02%
	Absorbed by sinks	8.7E+04	4.0%
	PM deposition	7.8E+03	0.4%
	In dust	8.1E+03	0.4%
	Total	2.2E+06	100%

- **HBCD in passenger vehicles**

The HBCD concentrations inside the cabin are shown in Figure_Apx G-7 and the concentrations in the settled dust are shown in Figure_Apx G-8. Note that we have assumed that all the dust particles are freshly introduced and the initial HBCD concentration in the dust is zero.

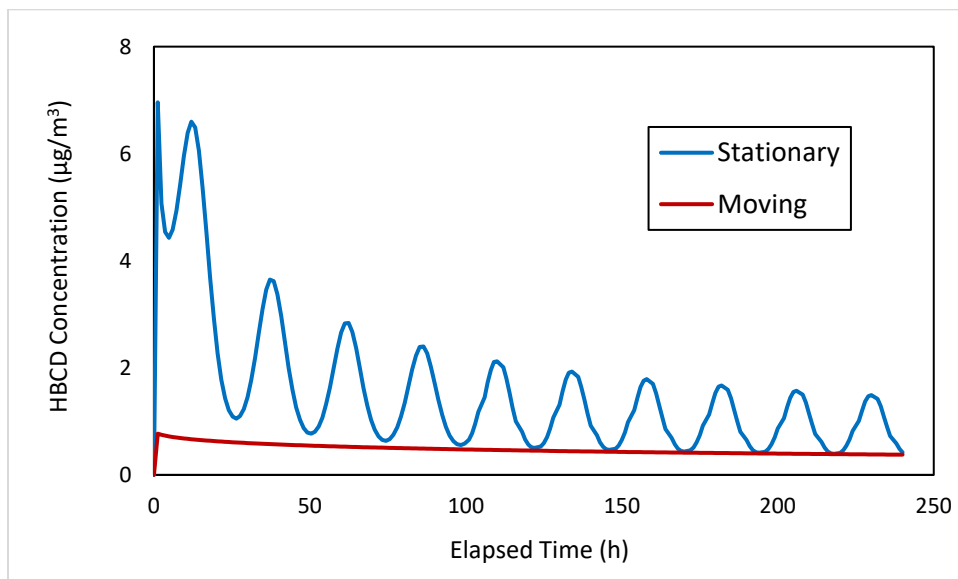

Figure_Apx G-7. Predicted HBCD Concentrations in Vehicle's Cabin

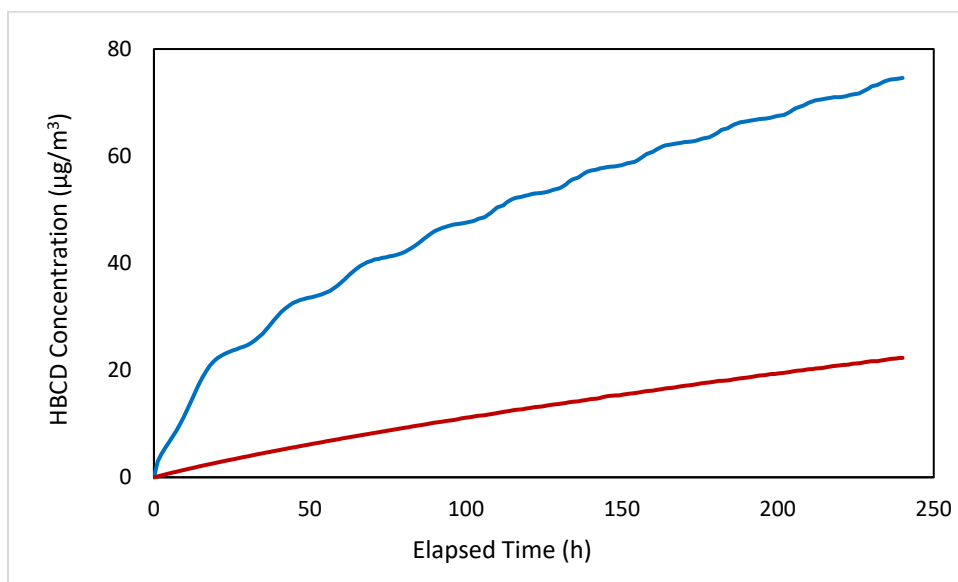

Figure_Apx G-8. Predicted HBCD Concentrations in the Settled Dust in Vehicle's Cabin. The Dust Contained no HBCD Initially

G.5.7 Discussion

- **XPS versus EPS foam boards**

Extruded polystyrene (XPS) insulation is manufactured through an extrusion process, which produces a closed-cell rigid insulation. In contrast, expanded polystyrene (EPS) insulation is manufactured using a mold to contain small foam beads. Heat or steam is then applied to the mold, which causes the small beads to expand and fuse together. This manufacturing process produces open-cell insulation (see <https://www.kingspan.com/meati/en-in/product-groups/insulation/knowledge-base/faqs/general/what-is-the-difference-between-xps-and-eps>).

The presence of interconnected voids in the EPS foam facilitates both heat and mass transfers in the foam. According to website <http://www.giasxps.ro/index.php/en/electronic-library-polystyrene/77-xps-eps-comparison>, the resistances to water vapor diffusion are as follows:

- Air = 1
- EPS = 50 – 70
- XPS = 50 – 250

These numbers suggest that the solid-phase diffusion coefficient for the low-performance XPS foam is about the same as that for the EPS foam and that the diffusion coefficient for the high-performance XPS foam can be as small as one fourth to one fifth of that for the EPS foam.

In ([Huang et al. 2017](#)), the XPS and EPS foams are lumped into a single material type. To evaluate the difference in HBCD emissions between XPS and EPS, EPA conducted several simulations in a single-zone setting (*i.e.*, a test chamber) by varying only the solid-phase diffusion coefficient:

Table_Apx G-31. Parameters Used in Comparing EPS and XPS Foams

Parameter	Value
Diffusion coef. predicted by (Huang et al. 2017):	3.2×10^{-12} (m ² /h) at 21 °C
Diffusion coef. used in the simulations:	1×10^{-12} and 5×10^{-12} (m ² /h)
Chamber volume	30 m ³
Ventilation rate	0.5 h ⁻¹
Source area	5 m ²
Source thickness	10 cm
Board density	28.9 kg/m ³
HBCD content	0.50% (equivalent to 1.45×10^8 µg/m ³)
Partition coef.	1.70×10^7 at 21 °C
Gas-phase mass transfer coefficient	1 m/h

As shown in Figure_Apx G-9, when D increases by a factor of 5 from 1×10^{-12} to 5×10^{-12} m²/h, the average concentration over a year increases from 0.49 to 0.84 µg/m³, an increase by a factor of 1.7. These results suggest that, if the XPS and EPS boards have the same HBCD content and the same density, then the emission from EPS boards can be twice as much as the emissions from high-performance XPS boards. However, the emission from the low-performance XPS boards is expected to be similar to that from the EPS boards.

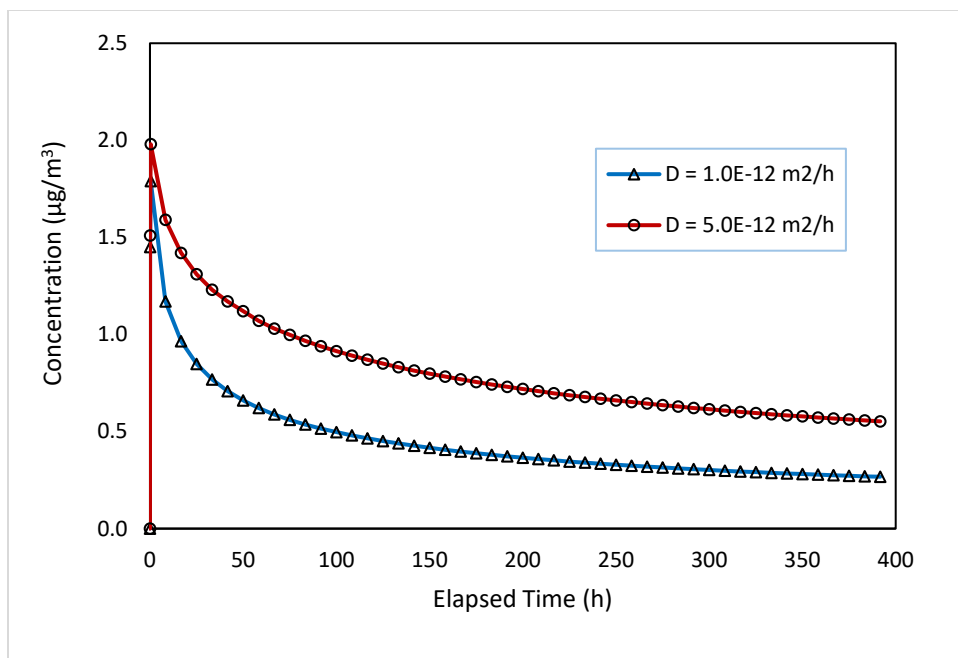

Figure_Apx G-9. Simulated HBCD Concentrations with Different Solid-phase Diffusion Coefficients

1. Effect of temperature on HBCD emission rates

The temperature dependence of HBCD emission rate from polystyrene foam boards is affected by both the partition and diffusion coefficients (K and D). In this work, the temperature dependent K and D were calculated from existing empirical models. To determine whether the models we used can reasonably predict the temperature dependence of the emission rate, we compared our simulation results with those in the 2012 report by Chemicals Evaluation and Research Institute, Japan (http://www.meti.go.jp/meti_lib/report/2012fy/E001880.pdf).

To make the data comparable, we normalized the emission rates according to:

$$N_R = \frac{R_T}{R_{T_0}}$$

where

N_R = normalized emission/diffusion rate (dimensionless)

R_T = emission rate at temperature T , $\mu\text{g}/\text{m}^2/\text{h}$,

R_{T_0} = emission rate at reference temperature T_0 , $\mu\text{g}/\text{m}^2/\text{h}$.

The single-zone model described was used to generate the HBCD emission rates. The temperature-dependent K s and D s were estimated.

As shown in Figure_Apx G-10, the predicted emission rates in this work are in good agreement with the data reported by the Japanese researchers ([Kataoka et al. 2012](#)).

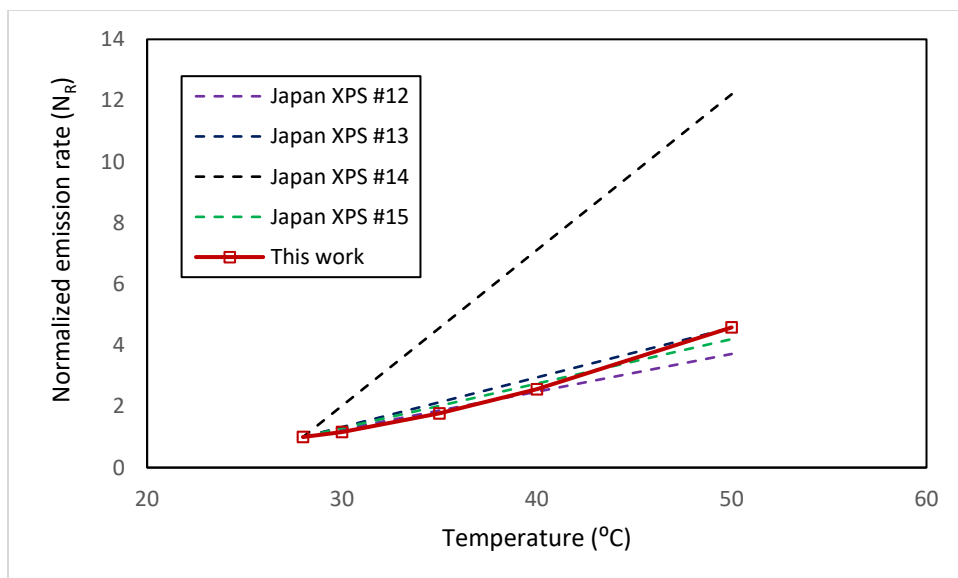

Figure_Apx G-10. Comparison of Normalized Emission Rates

The four dotted lines are from Tables 3-2-25 and 3-2-26 in the Japanese report. The reference temperature is $T_0 = 28^{\circ}\text{C}$.

2. “Faced” versus “unfaced” insulation boards

The simulation results presented above are applicable to “unfaced” insulation boards and boards with a permeable facer (*e.g.*, paper and fabrics). The results are not applicable to the boards with both sides covered with a nonpermeable facer such as foil. It is our understanding that most sheathing insulation boards on the market have one side covered by foil. When installed, the foil side faces the exterior of the building.

Appendix H ENVIRONMENTAL HAZARDS

H.1 Supplemental Environmental Hazard Information

See Supplemental Document:

Risk Evaluation for Cyclic Aliphatic Bromide Cluster (HBCD), [Systematic Review Supplemental File: Data Extraction Tables of Environmental Hazard Studies](#). (U.S. EPA 2019b)

H.2 Calculations Used to Evaluate the Potential Trophic Transfer of HBCD

The below calculations were used to calculate food and HBCD ingestion, as presented above in Table 3-2 and Table 3-3

Legend:

C_{predator} : Amount of food consumed by predator

BW_{predator} : Predator body weight

Equation 1: Calculation used to quantify food ingestion by a predator

$$\frac{\text{amount of food consumed by predator}}{BW_{\text{predator}} * \text{day}} * \% \text{ food type in predator diet} * BW_{\text{predator}} = \frac{\text{amount of food consumed by predator}}{d}$$

Equation 2: Calculation used to quantify HBCD ingestion by a predator

$$\frac{g \text{ food consumed by predator}}{d} * \frac{ng \text{ HBCD}}{g \text{ food}} = \frac{\text{amount of HBCD consumed by predator}}{d}$$

Equation 3: Calculation used to quantify allometrically-scaled osprey reproductive LOEC based on kestrel reproductive LOEC (Fernie et al., 2011)

$$\frac{\text{Kestrel Reproductive LOEC} \left(\frac{ng \text{ HBCD}}{d} \right)}{\text{Osprey BW (g)}} = \text{Osprey Reproductive LOEC} \left(\frac{ng \text{ HBCD}}{g \text{ BW per day}} \right)$$

$$\frac{70,380 \text{ ng} \frac{\text{HBCD}}{d}}{1,725 \text{ g}} = \frac{40.8 \text{ ng HBCD}}{g \text{ BW per day}} = \text{Osprey Reproductive LOEC}$$

H.3 KABAM Outputs for Aquatic HBCD Bioaccumulation and Bioconcentration

H.3.1 10th Percentile Surface and Pore Water Concentrations

The outputs from KABAM (v1) are provided below, per sub-scenario- and HBCD-specific release information and physiochemical properties, respectively. Both sub-scenarios (3.3 and 5.7) are modeled with the assumption that the releases and subsequent surface water and pore water concentrations are based on a 75% removal of HBCD from the direct releases of HBCD into surface water. The outputs below are also based on the HBCD half-life of 128 days. Further information regarding the trophic level designations and calculations for the output parameters are available at: https://www.epa.gov/sites/production/files/2015-07/documents/kabam_v1_0_users_guide.pdf.

Condition of Use	Sub-Scenario	Production Volume (lbs/yr)	Trophic Level	Total concentration (µg/kg-ww)	Lipid normalized concentration (µg/kg-lipid)	Contribution due to diet (µg/kg-ww)	Total BCF (µg/kg-ww)/(µg/L)	Total BAF (µg/kg-ww)/(µg/L)	BCF (µg/kg-lipid)/(µg/L)	BAF (µg/kg-lipid)/(µg/L)	BMF (µg/kg-lipid)/(µg/kg-lipid)	BSAF (µg/kg-lipid)/(µg/kg-OC)
Processing: Manufacturing of XPS Foam using XPS Masterbatch	3.3	100,000	Phytoplankton	18676.00	933799.77	N/A	20010.63	17454.20	1000531.52	872710.07	N/A	31.98
			Zooplankton	16672.34	555744.59	1745.38	14257.78	15581.62	475259.43	519387.47	0.60	19.03
			Benthic Invertebrates	19749.81	658327.12	4696.47	15004.75	18457.77	500158.39	615258.99	1.34	22.55
			Filter Feeders	12943.12	647155.76	3029.45	9862.90	12096.37	493144.94	604818.47	1.32	22.16
			Small Fish	38714.05	967851.24	20981.21	19303.06	36181.35	482576.58	904533.87	1.59	33.15
			Medium Fish	63361.90	1584047.59	47561.14	19303.06	59216.73	482576.58	1480418.31	1.95	54.25
			Large Fish	154955.55	3873888.81	140823.26	20031.30	144818.27	500782.60	3620456.83	2.45	132.67
		50,000	Phytoplankton	9425.27	471263.44	N/A	20010.63	17454.20	1000531.52	872710.07	N/A	32.06
			Zooplankton	8414.08	280469.23	880.84	14257.78	15581.62	475259.43	519387.47	0.60	19.08
			Benthic Invertebrates	9966.74	332224.55	2369.99	15004.23	18456.92	500140.87	615230.66	1.34	22.60
			Filter Feeders	6531.74	326586.99	1528.76	9862.55	12095.81	493127.67	604790.71	1.32	22.22
			Small Fish	19537.35	488433.84	10588.38	19302.39	36180.28	482559.67	904507.12	1.59	33.23
			Medium Fish	31975.91	799397.82	24001.97	19302.39	59214.65	482559.67	1480366.33	1.95	54.38
			Large Fish	78199.37	1954984.30	71067.19	20031.30	144813.65	500782.60	3620341.30	2.45	132.99
25,000	Phytoplankton	4695.18	234759.01	N/A	20010.63	17454.20	1000531.52	872710.07	N/A	31.94		
	Zooplankton	4191.46	139715.23	438.79	14257.78	15581.62	475259.43	519387.47	0.60	19.01		

The outputs from KABAM (v1) are provided below, per sub-scenario- and HBCD-specific release information and physiochemical properties, respectively. Both sub-scenarios (3.3 and 5.7) are modeled with the assumption that the releases and subsequent surface water and pore water concentrations are based on a 75% removal of HBCD from the direct releases of HBCD into surface water. The outputs below are also based on the HBCD half-life of 128 days. Further information regarding the trophic level designations and calculations for the output parameters are available at: https://www.epa.gov/sites/production/files/2015-07/documents/kabam_v1_0_users_guide.pdf.

Condition of Use	Sub-Scenario	Production Volume (lbs/yr)	Trophic Level	Total concentration (µg/kg-ww)	Lipid normalized concentration (µg/kg-lipid)	Contribution due to diet (µg/kg-ww)	Total BCF (µg/kg-ww)/(µg/L)	Total BAF (µg/kg-ww)/(µg/L)	BCF (µg/kg-lipid)/(µg/L)	BAF (µg/kg-lipid)/(µg/L)	BMF (µg/kg-lipid)/(µg/kg-lipid)	BSAF (µg/kg-lipid)/(µg/kg-OC)
			Benthic Invertebrates	4965.25	165508.48	1180.75	15005.01	18458.19	500167.14	615273.14	1.34	22.52
			Filter Feeders	3254.00	162699.89	761.64	9863.07	12096.65	493153.56	604832.32	1.32	22.14
			Small Fish	9732.93	243323.21	5274.78	19303.40	36181.89	482585.01	904547.23	1.59	33.11
			Medium Fish	15929.58	398239.51	11957.17	19303.40	59217.77	482585.01	1480444.27	1.95	54.18
			Large Fish	38956.74	973918.40	35403.85	20031.30	144820.58	500782.60	3620514.51	2.45	132.51
			Phytoplankton	774146.19	38707309.59	N/A	20010.63	17454.20	1000531.52	872710.07	N/A	10.90
			Zooplankton	691091.77	23036392.32	72348.24	14257.78	15581.62	475259.43	519387.47	0.60	6.49
		100,000	Benthic Invertebrates	848124.80	28270826.57	207064.12	15415.43	19122.15	513847.74	637405.06	1.39	7.96
		100,000	Filter Feeders	555749.04	27787451.92	133566.50	10132.85	12530.13	506642.33	626506.71	1.36	7.83
		100,000	Small Fish	1641844.84	41046121.09	886675.31	19831.39	37017.67	495784.71	925441.82	1.60	11.56
		100,000	Medium Fish	2698514.01	67462850.15	2025623.68	19831.39	60841.75	495784.71	1521043.68	1.95	19.00
		100,000	Large Fish	6583311.56	164582789.06	5997508.21	20031.30	148429.90	500782.60	3710747.62	2.44	46.36
		50,000	Phytoplankton	708116.95	35405847.41	N/A	20010.63	17454.20	1000531.52	872710.07	N/A	17.97
		50,000	Zooplankton	632146.49	21071549.53	66177.44	14257.78	15581.62	475259.43	519387.47	0.60	10.70
		50,000	Benthic Invertebrates	759699.33	25323311.02	182639.83	15170.33	18725.64	505677.82	624188.10	1.36	12.85
		50,000	Filter Feeders	497845.00	24892249.96	117811.64	9971.74	12271.26	498586.97	613562.98	1.34	12.64
		50,000	Small Fish	1481557.62	37038940.43	801781.47	19516.08	36518.55	487901.98	912963.78	1.60	18.80
		50,000	Medium Fish	2429003.97	60725099.21	1823292.57	19516.08	59871.92	487901.98	1496798.11	1.95	30.82
		50,000	Large Fish	5934354.51	148358862.71	5398516.08	20031.30	146274.45	500782.60	3656861.29	2.44	75.31
Processing: Manufacturing of EPS Foam from Imported EPS Resin beads	5.7											

The outputs from KABAM (v1) are provided below, per sub-scenario- and HBCD-specific release information and physiochemical properties, respectively. Both sub-scenarios (3.3 and 5.7) are modeled with the assumption that the releases and subsequent surface water and pore water concentrations are based on a 75% removal of HBCD from the direct releases of HBCD into surface water. The outputs below are also based on the HBCD half-life of 128 days. Further information regarding the trophic level designations and calculations for the output parameters are available at: https://www.epa.gov/sites/production/files/2015-07/documents/kabam_v1_0_users_guide.pdf.

Condition of Use	Sub-Scenario	Production Volume (lbs/yr)	Trophic Level	Total concentration (µg/kg-ww)	Lipid normalized concentration (µg/kg-lipid)	Contribution due to diet (µg/kg-ww)	Total BCF (µg/kg-ww)/(µg/L)	Total BAF (µg/kg-ww)/(µg/L)	BCF (µg/kg-lipid)/(µg/L)	BAF (µg/kg-lipid)/(µg/L)	BMF (µg/kg-lipid)/(µg/kg-lipid)	BSAF (µg/kg-lipid)/(µg/kg-OC)
		25,000	Phytoplankton	677746.64	33887331.89	N/A	20010.63	17454.20	1000531.52	872710.07	N/A	25.48
			Zooplankton	605034.46	20167815.34	63339.17	14257.78	15581.62	475259.43	519387.47	0.60	15.16
			Benthic Invertebrates	720120.12	24004003.88	171865.05	15058.95	18545.46	501965.16	618181.92	1.35	18.05
			Filter Feeders	471925.04	23596251.88	110861.37	9898.53	12153.62	494926.38	607680.97	1.32	17.74
			Small Fish	1409208.09	35230202.20	763363.57	19372.79	36291.74	484319.84	907293.39	1.60	26.49
			Medium Fish	2307713.82	57692845.46	1732237.04	19372.79	59431.21	484319.84	1485780.21	1.95	43.38
			Large Fish	5641802.93	141045073.25	5128945.99	20031.30	145294.95	500782.60	3632373.76	2.44	106.05

H.3.2 50th Percentile Surface and Pore Water Concentrations

The outputs from KABAM (v1) are provided below, per sub-scenario- and HBCD-specific release information and physiochemical properties, respectively. Both sub-scenarios (3.3 and 5.7) are modeled with the assumption that the releases and subsequent surface water and pore water concentrations are based on a 75% removal of HBCD from the direct releases of HBCD into surface water. The outputs below are also based on the HBCD half-life of 128 days. Further information regarding the trophic level designations and calculations for the output parameters are available at: https://www.epa.gov/sites/production/files/2015-07/documents/kabam_v1_0_users_guide.pdf.

Condition of Use	Sub-Scenario	Production Volume (lbs/yr)	Trophic Level	Total concentration (µg/kg-ww)	Lipid normalized concentration (µg/kg-lipid)	Contribution due to diet (µg/kg-ww)	Total BCF (µg/kg-ww)/(µg/L)	Total BAF (µg/kg-ww)/(µg/L)	BCF (µg/kg-lipid)/(µg/L)	BAF (µg/kg-lipid)/(µg/L)	BMF (µg/kg-lipid)/(µg/kg-lipid)	BSAF (µg/kg-lipid)/(µg/kg-OC)
Processing: Manufacturing of XPS Foam using XPS Masterbatch	3.3	100,000	Phytoplankton	453.81	22690.46	N/A	20010.63	17454.20	1000531.52	872710.07	N/A	30.66
			Zooplankton	405.12	13504.07	42.41	14257.78	15581.62	475259.43	519387.47	0.60	18.25
			Benthic Invertebrates	480.29	16009.52	114.28	15013.87	18472.53	500462.49	615750.96	1.34	21.63
			Filter Feeders	314.76	15737.81	73.72	9868.90	12106.01	493444.78	605300.26	1.32	21.27
			Small Fish	941.20	23529.96	510.04	19314.80	36199.93	482869.99	904998.33	1.59	31.80
			Medium Fish	1540.57	38514.34	1156.40	19314.80	59252.83	482869.99	1481320.79	1.95	52.05
			Large Fish	3767.36	94184.03	3423.96	20031.30	144898.50	500782.60	3622462.60	2.45	127.28
		50,000	Phytoplankton	232.14	11607.04	N/A	20010.63	17454.20	1000531.52	872710.07	N/A	29.02
			Zooplankton	207.24	6907.85	21.69	14257.78	15581.62	475259.43	519387.47	0.60	17.27
			Benthic Invertebrates	245.95	8198.50	58.57	15026.44	18492.85	500881.26	616428.42	1.34	20.50
			Filter Feeders	161.19	8059.32	37.78	9877.15	12119.27	493857.67	605963.72	1.32	20.15
			Small Fish	481.80	12044.98	261.06	19330.96	36225.52	483274.03	905637.92	1.59	30.11
			Medium Fish	788.72	19718.10	592.04	19330.96	59302.54	483274.03	1482563.54	1.95	49.30
			Large Fish	1928.62	48215.49	1752.96	20031.30	145008.99	500782.60	3625224.65	2.45	120.54
		25,000	Phytoplankton	116.94	5847.16	N/A	20010.63	17454.20	1000531.52	872710.07	N/A	31.44
			Zooplankton	104.40	3479.90	10.93	14257.78	15581.62	475259.43	519387.47	0.60	18.71
			Benthic Invertebrates	123.71	4123.56	29.42	15008.42	18463.71	500280.74	615456.93	1.34	22.17

The outputs from KABAM (v1) are provided below, per sub-scenario- and HBCD-specific release information and physiochemical properties, respectively. Both sub-scenarios (3.3 and 5.7) are modeled with the assumption that the releases and subsequent surface water and pore water concentrations are based on a 75% removal of HBCD from the direct releases of HBCD into surface water. The outputs below are also based on the HBCD half-life of 128 days. Further information regarding the trophic level designations and calculations for the output parameters are available at: https://www.epa.gov/sites/production/files/2015-07/documents/kabam_v1_0_users_guide.pdf.

Condition of Use	Sub-Scenario	Production Volume (lbs/yr)	Trophic Level	Total concentration (µg/kg-ww)	Lipid normalized concentration (µg/kg-lipid)	Contribution due to diet (µg/kg-ww)	Total BCF (µg/kg-ww)/(µg/L)	Total BAF (µg/kg-ww)/(µg/L)	BCF (µg/kg-lipid)/(µg/L)	BAF (µg/kg-lipid)/(µg/L)	BMF (µg/kg-lipid)/(µg/kg-lipid)	BSAF (µg/kg-lipid)/(µg/kg-OC)
			Filter Feeders	81.07	4053.58	18.98	9865.31	12100.25	493265.58	605012.31	1.32	21.79
			Small Fish	242.47	6061.63	131.40	19307.79	36188.83	482694.63	904720.75	1.59	32.59
			Medium Fish	396.85	9921.24	297.89	19307.79	59231.26	482694.63	1480781.42	1.95	53.34
			Large Fish	970.50	24262.47	882.01	20031.30	144850.55	500782.60	3621263.84	2.45	130.44
Processing: Manufacturing of EPS Foam from Imported EPS Resin beads	5.7	100,000	Phytoplankton	16511.67	825583.72	N/A	20010.63	17454.20	1000531.52	872710.07	N/A	10.89
			Zooplankton	14740.22	491340.54	1543.11	14257.78	15581.62	475259.43	519387.47	0.60	6.48
			Benthic Invertebrates	18090.59	603019.81	4416.88	15416.11	19123.25	513870.36	637441.65	1.39	7.96
			Filter Feeders	11854.18	592709.25	2849.11	10133.29	12530.85	506664.63	626542.55	1.36	7.82
			Small Fish	35020.03	875500.65	18912.39	19832.26	37019.05	495806.53	925476.37	1.60	11.55
			Medium Fish	57558.83	1438970.82	43206.20	19832.26	60844.43	495806.53	1521110.81	1.95	18.98
			Large Fish	140420.34	3510508.39	127925.80	20031.30	148435.87	500782.60	3710896.82	2.44	46.31
		50,000	Phytoplankton	16511.67	825583.72	N/A	20010.63	17454.20	1000531.52	872710.07	N/A	19.20
			Zooplankton	14740.22	491340.54	1543.11	14257.78	15581.62	475259.43	519387.47	0.60	11.43
			Benthic Invertebrates	17677.48	589249.35	4243.20	15146.17	18686.55	504872.41	622885.15	1.36	13.70
			Filter Feeders	11584.47	579223.47	2737.07	9955.86	12245.74	497792.86	612286.97	1.33	13.47
			Small Fish	34500.00	862500.06	18674.42	19485.00	36469.35	487124.89	911733.67	1.60	20.06
			Medium Fish	56548.40	1413709.92	42447.08	19485.00	59776.32	487124.89	1494407.95	1.95	32.88
			Large Fish	138174.62	3454365.46	125680.09	20031.30	146061.96	500782.60	3651549.11	2.44	80.33
25,000	Phytoplankton	16511.67	825583.72	N/A	20010.63	17454.20	1000531.52	872710.07	N/A	26.89		
	Zooplankton	14740.22	491340.54	1543.11	14257.78	15581.62	475259.43	519387.47	0.60	16.00		

The outputs from KABAM (v1) are provided below, per sub-scenario- and HBCD-specific release information and physiochemical properties, respectively. Both sub-scenarios (3.3 and 5.7) are modeled with the assumption that the releases and subsequent surface water and pore water concentrations are based on a 75% removal of HBCD from the direct releases of HBCD into surface water. The outputs below are also based on the HBCD half-life of 128 days. Further information regarding the trophic level designations and calculations for the output parameters are available at: https://www.epa.gov/sites/production/files/2015-07/documents/kabam_v1_0_users_guide.pdf.

Condition of Use	Sub-Scenario	Production Volume (lbs/yr)	Trophic Level	Total concentration (µg/kg-ww)	Lipid normalized concentration (µg/kg-lipid)	Contribution due to diet (µg/kg-ww)	Total BCF (µg/kg-ww)/(µg/L)	Total BAF (µg/kg-ww)/(µg/L)	BCF (µg/kg-lipid)/(µg/L)	BAF (µg/kg-lipid)/(µg/L)	BMF (µg/kg-lipid)/(µg/kg-lipid)	BSAF (µg/kg-lipid)/(µg/kg-OC)
			Benthic Invertebrates	17522.56	584085.43	4178.07	15044.95	18522.79	501498.19	617426.46	1.34	19.03
			Filter Feeders	11483.33	574166.30	2695.06	9889.32	12138.82	494465.95	606941.12	1.32	18.70
			Small Fish	34304.99	857624.8	18585.18	19354.77	36263.21	483869.3	906580.2	1.594949	27.93566
			Medium Fish	56169.48	1404237	42162.41	19354.77	59375.77	483869.3	1484394	1.948016	45.74062
			Large Fish	137332.5	3433312	124837.9	20031.3	145171.7	500782.6	3629294	2.444966	111.8343

Appendix I BMD MODELING RESULTS FOR SELECTED PODs

I.1 Noncancer Endpoints for BMD Modeling

The noncancer endpoints that were selected for dose-response modeling are presented in Table_Apx I-1. For each endpoint, the doses and response data used for the modeling are presented.

Table_Apx I-1. Noncancer Endpoints Selected for Dose-response Modeling for HBCD

Endpoint	Species (strain)/sex	Dose (mg/kg-d) ^a	Incidence [%] or mean \pm SD (number of animals or litters)	BMR(s)
Thyroid				
↓T4 Ema et al. (2008)	F0 rats (CRL Sprague-Dawley)/male	0 10 101 1,008 TWA of lifetime exposure, F0	4.04 \pm 1.42 (8) 3.98 \pm 0.89 (8) 2.97 \pm 0.76 (8) 2.49 \pm 0.55 (8)	10% RD, 15% RD, 20% RD, 1 SD
↓T4 Ema et al. (2008)	F0 rats (CRL Sprague-Dawley)/female	0 14 141 1,363 TWA of lifetime exposure, F0	2.84 \pm 0.61 (8) 3.14 \pm 0.48 (8) 3.00 \pm 0.77 (8) 1.96 \pm 0.55 (8)	10% RD, 15% RD, 20% RD, 1 SD
↓T4 Ema et al. (2008)	F1 rats (CRL Sprague-Dawley)/female	0 14.3 138 1,363 TWA of lifetime exposure, F1	3.59 \pm 1.08 (8) 3.56 \pm 0.53 (8) 3.39 \pm 1.21 (8) 2.58 \pm 0.37 (8)	10% RD, 15% RD, 20% RD, 1 SD
Liver				
Relative liver weight Ema et al. (2008)	F1 rats (CRL Sprague-Dawley)/male weanlings, PND 26	0 16.5 168 1,570 TWA of F0 gestational and lactational doses	4.6 \pm 0.37 (23) 4.6 \pm 0.32 (21) 5.05 \pm 0.32 (20) 6 \pm 0.44 (17)	10% RD, 1 SD
Relative liver weight Ema et al. (2008)	F1 rats (CRL Sprague-Dawley)/female weanlings, PND 26	0 16.5 168 1,570 TWA of F0 gestational and lactational doses	4.57 \pm 0.35 (23) 4.59 \pm 0.28 (21) 5.02 \pm 0.32 (20) 6.07 \pm 0.36 (14)	10% RD, 1 SD
Relative liver weight Ema et al. (2008)	F1 rats (CRL Sprague-Dawley)/male adults	0 11.4 115 1,142	3.27 \pm 0.18 (24) 3.34 \pm 0.26 (24) 3.37 \pm 0.25 (22) 3.86 \pm 0.28 (24)	10% RD, 1 SD

Endpoint	Species (strain)/sex	Dose (mg/kg-d) ^a	Incidence [%] or mean \pm SD (number of animals or litters)	BMR(s)
		TWA of lifetime exposure, F1		
Relative liver weight Ema et al. (2008)	F1 rats (CRL Sprague-Dawley)/female adults	0 14.3 138 1,363 TWA of lifetime exposure, F1	4.18 \pm 0.42 (22) 4.39 \pm 0.44 (22) 4.38 \pm 0.47 (20) 5.05 \pm 0.50 (13)	10% RD, 1 SD
Relative liver weight Ema et al. (2008)	F2 rats (CRL Sprague-Dawley)/male weanlings, PND 26	0 14.7 139 1,360 TWA of F1 gestational and lactational doses	4.72 \pm 0.59 (22) 4.74 \pm 0.35 (22) 5.04 \pm 0.4 (18) 6.0 \pm 0.25 (13)	10% RD, 1 SD
Relative liver weight Ema et al. (2008)	F2 rats (CRL Sprague-Dawley)/female weanlings, PND 26	0 14.7 139 1,360 TWA of F1 gestational and lactational doses	4.70 \pm 0.27 (21) 4.70 \pm 0.28 (22) 4.94 \pm 0.32 (20) 5.89 \pm 0.44 (13)	10% RD, 1 SD
Relative liver weight WIL Research (2001)	Rats (Sprague-Dawley)/male	0 100 300 1,000	2.709 \pm 0.1193 (10) 3.175 \pm 0.2293 (10) 3.183 \pm 0.2653 (10) 3.855 \pm 0.1557 (9)	10% RD, 1 SD
Relative liver weight WIL Research (2001)	Rats (Sprague-Dawley)/female	0 100 300 1,000	2.887 \pm 0.2062 (10) 3.583 \pm 0.2734 (10) 3.578 \pm 0.3454 (10) 4.314 \pm 0.2869 (10)	10% RD, 1 SD
Reproductive				
Primordial follicles Ema et al. (2008) (supplemental)	F1 parental rat (CRL Sprague-Dawley)/female	0 9.6 96 941 The F0 adult female gestational doses	316.3 \pm 119.5 (10) 294.2 \pm 66.3 (10) 197.9 \pm 76.9 (10) 203.4 \pm 79.5 (10)	1% RD, 5% RD, 10% RD
Developmental				
Offspring loss at PND 4 Ema et al. (2008)	F2 offspring rats (CRL Sprague-Dawley)	0 9.7 100 995 The F1 adult female gestational doses	28/132 [21%] 26/135 [19.3%] 23/118 [19.5%] 47/120 [39.2%]	1% ER, 5% ER

Endpoint	Species (strain)/sex	Dose (mg/kg-d) ^a	Incidence [%] or mean \pm SD (number of animals or litters)	BMR(s)
Offspring loss at PND 21 Ema et al. (2008)	F2 offspring rats (CRL Sprague-Dawley)	0 19.6 179 1,724 The F1 adult female lactational doses	11/70 [15.7%] 7/70 [10.0%] 18/64 [28.1%] 32/64 [50.0%]	1% ER, 5% ER
Pup weight during lactation at PND 21 Ema et al. (2008)	F2 offspring rats (CRL Sprague-Dawley)/male	0 19.6 179 1,724 The F1 adult female lactational doses	53 \pm 12.6 (22) 56.2 \pm 6.7 (22) 54.1 \pm 10.1 (18) 42.6 \pm 8.3 (13)	5% RD, 10% RD, 0.5 SD, 1 SD
Pup weight during lactation at PND 21 Ema et al. (2008)	F2 offspring rats (CRL Sprague-Dawley)/female	0 19.6 179 1,724 The F1 adult female lactational doses	52 \pm 10 (21) 52.8 \pm 6.6 (22) 51.2 \pm 10.8 (20) 41.6 \pm 8.4 (13)	5% RD, 10% RD, 0.5 SD, 1 SD
Delayed eye opening, (Ema et al. 2008)	F2 offspring rats (CRL Sprague-Dawley)/female	0 15 139 1,360	82.9 \pm 26.8 (21) 72.7 \pm 37.7 (22) 53.8 \pm 40.3 (20) 48.1 \pm 42.0 (13)	5% ER, 10% ER
Delayed eye opening (Ema et al. 2008)	F2 offspring rats (CRL Sprague-Dawley)/male	0 15 139 1,360	72.7 \pm 40.0 (22) 62.5 \pm 40.6 (22) 47.2 \pm 44.8 (18) 33.9 \pm 34.7 (14)	NOAEL

^aDoses were calculated as TWA doses using weekly average doses (in mg/kg-day) as reported in Table 10 of the Supplemental Materials to [Ema et al. \(2008\)](#).

BMR = benchmark response; ER = extra risk; PND = postnatal day; RD = relative deviation; SD = standard deviation; T4 = thyroxine; TWA = time-weighted average

I.1.1 Thyroid Effects

Table_Apx I-2. Summary of BMD modeling results for T4 in F0 parental male CRL Sprague-Dawley rats exposed to HBCD by diet for 18 weeks ([Ema et al. 2008](#)); BMR = 10% RD from control mean

Model ^a	Goodness of fit		BMD _{10RD} (mg/kg-d)	BMDL _{10RD} (mg/kg-d)	BMD _{15RD} (mg/kg-d)	BMDL _{15RD} (mg/kg-d)	Basis for model selection
	p-value	AIC					
Exponential (M2) Exponential (M3) ^b	0.0473	33.926	259	177	399	274	Of the models without saturation that provided an adequate fit and a valid BMDL estimate, the Exponential 4 model with modeled variance
Exponential (M4) Exponential (M5)^c	0.742	29.933	23.9	6.99	39.1	11.5	
Hill	0.949	29.829	14.4	3.21	25.6	5.66	
Power ^d Polynomial 3 ^{oe} Polynomial 2 ^{of}	0.0418	34.174	303	227	455	341	

Model ^a	Goodness of fit		BMD _{10RD} (mg/kg-d)	BMDL _{10RD} (mg/kg-d)	BMD _{15RD} (mg/kg-d)	BMDL _{15RD} (mg/kg-d)	Basis for model selection was selected based on lowest AIC (BMDLs differed by <3).
	p-value	AIC					
Linear							
Model ^a	Goodness of fit		BMD _{20RD} (mg/kg-d)	BMDL _{20RD} (mg/kg-d)	BMD _{1SD} (mg/kg-d)	BMDL _{1SD} (mg/kg-d)	
p-value	AIC						
Exponential (M2) Exponential (M3) ^b	0.0473	33.926	548	376	866	511	
Exponential (M4) Exponential (M5) ^c	0.742	29.933	57.9	17.2	101	29.5	
Hill	0.949	29.829	42.0	9.11	94.9	Error ^g	
Power ^d Polynomial 3 ^o ^e Polynomial 2 ^o ^f Linear	0.0418	34.174	607	454	906	595	

^aModeled variance case presented (BMDS Test 2 p -value = 0.0756, BMDS Test 3 p -value = 0.553), selected model in bold; scaled residuals for selected model for doses 0, 10.2, 101, and 1,008 mg/kg-day were -0.1665, 0.166, 0.03642, and -0.03619, respectively.

^bFor the Exponential (M3) model, the estimate of d was 1 (boundary). The models in this row reduced to the Exponential (M2) model.

^cFor the Exponential (M5) model, the estimate of d was 1 (boundary). The models in this row reduced to the Exponential (M4) model.

^dFor the Power model, the power parameter estimate was 1. The models in this row reduced to the Linear model.

^eFor the Polynomial 3^o model, the b_3 coefficient estimate was 0 (boundary of parameters space). The models in this row reduced to the Polynomial 2^o model. For the Polynomial 3^o model, the b_3 and b_2 coefficient estimates were 0 (boundary of parameters space). The models in this row reduced to the Linear model.

^fFor the Polynomial 2^o model, the b_2 coefficient estimate was 0 (boundary of parameters space). The models in this row reduced to the Linear model.

^gBMD or BMDL computation failed for this model.

Data from [Ema et al. \(2008\)](#)

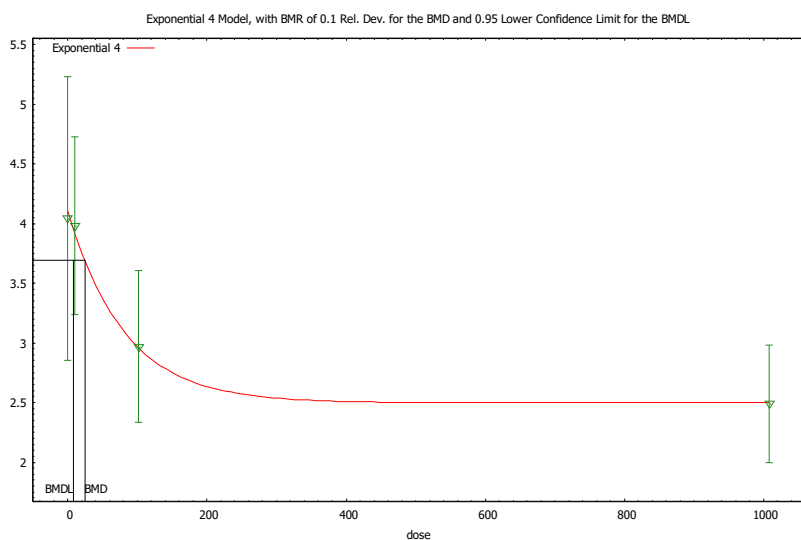

BMR = 10% RD from control mean; dose shown in mg/kg-day.

Figure_Apx I-1. Plot of mean response by dose, with fitted curve for Exponential 4 Model, for T4 in F0 parental CRL Sprague-Dawley male rats exposed to HBCD by diet for 18 weeks ([Ema et al. 2008](#)).

Exponential 4 Model (Version: 1.10; Date: 01/12/2015)

The form of the response function is:

Model 4: $Y[\text{dose}] = a * [c - (c - 1) * \exp(-b * \text{dose})]$

A modeled variance is fit

Benchmark Dose Computation

BMR = 10% RD

BMD = 23.8946

BMDL at the 95% confidence level = 6.99406

Parameter Estimates

Variable	Estimate	Default initial parameter values
lalpha	-3.94284	-3.54227
rho	2.98463	2.72754
a	4.1075	4.242
b	0.0123219	0.00282274
d	1 (specified)	1 (specified)

Table of Data and Estimated Values of Interest

Dose	N	Observed mean	Estimated mean	Observed SD	Estimated SD	Scaled residuals
0	8	4.04	4.11	1.42	1.15	-0.167
10.2	8	3.98	3.92	0.89	1.07	0.166
101	8	2.97	2.961	0.76	0.71	0.036
1,008	8	2.49	2.50	0.59	0.56	-0.036

Likelihoods of Interest

Model	Log (likelihood)	Number of parameters	AIC
A1	-12.76333	5	35.52665
A2	-9.319925	8	34.63985
A3	-9.91228	6	31.82456
fitted	-9.966286	5	29.93257
R	-19.64317	2	43.28634

Tests of Interest

Test	-2*log (likelihood ratio)	Test df	p-value
Test 1	20.65	6	0.002123
Test 2	6.887	3	0.07559
Test 3	1.185	2	0.553
Test 6a	0.108	1	0.7424

df = degree(s) of freedom

I.1.2 Liver Effects

Table_Apx I-3. Summary of BMD modeling results for relative liver weight (g/100 g BW) in male F1 CRL rats exposed to HBCD on GD 0–PND 26, dose TWA gestation through lactation (Ema et al. 2008); BMR = 10% RD from control mean and 1 SD change from control mean

Model ^a	Goodness of fit		BMD _{10RD} (mg/kg-d)	BMDL _{10RD} (mg/kg-d)	BMD _{1SD} (mg/kg-d)	BMDL _{1SD} (mg/kg-d)	Basis for model selection
	p-value	AIC					
Exponential (M2) Exponential (M3) ^b	0.00369	-70.405	599	533	488	417	Of the models that provided an adequate fit and a valid BMDL estimate, the Exponential M4 constant variance model was selected based on lowest AIC and visual fit.
Exponential (M4)	0.606	-79.345	163	109	120	80.5	
Exponential (M5)	N/A ^c	-77.611	169	111	157	82.0	
Hill	N/A ^c	-77.611	169	104	156	75.4	
Powerd Polynomial 3 ^o ^e Polynomial 2 ^o ^f Linear	0.00590	-71.344	548	480	440	371	

^aConstant variance case presented (BMDs Test 2 p -value = 0.462), selected model in bold; scaled residuals for selected model for doses 0, 16.5, 168, and 1,570 mg/kg-day were 0.3267, -0.3947, 0.05759, and -0.003788, respectively.

^bFor the Exponential (M3) model, the estimate of d was 1 (boundary). The models in this row reduced to the Exponential (M2) model.

^cNo available degrees of freedom to calculate a goodness-of-fit value.

^dFor the Power model, the power parameter estimate was 1. The models in this row reduced to the Linear model.

^eFor the Polynomial 3^o model, the b_3 and b_2 coefficient estimates were 0 (boundary of parameters space). The models in this row reduced to the Linear model.

^fFor the Polynomial 2^o model, the b_2 coefficient estimate was 0 (boundary of parameters space). The models in this row reduced to the Linear model.

Data from [Ema et al. \(2008\)](#)

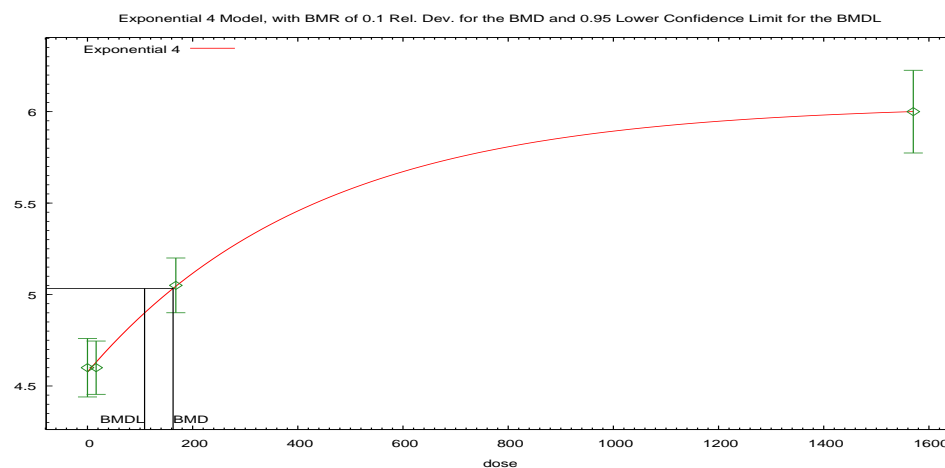

BMR = 10% RD from control mean; dose shown in mg/kg-day.

Figure_Apx I-2. Plot of mean response by dose with fitted curve for Exponential (M4) model with constant variance for relative liver weight (g/100 g BW) in F1 weanling male CRL Sprague-Dawley rats exposed to HBCD on GD 0–PND 26, dose TWA gestation through lactation (Ema et al. 2008).

Exponential Model (Version: 1.10; Date: 01/12/2015)The form of the response function is: $Y[\text{dose}] = a * [c - (c - 1) * \exp(-b * \text{dose})]$

A constant variance model is fit

Benchmark Dose Computation

BMR = 10% RD

BMD = 162.81

BMDL at the 95% confidence level = 108.569

Parameter Estimates

Variable	Estimate	Default initial parameter values
Inalpha	-2.07833	-2.08162
rho	N/A	0
a	4.5759	4.37
b	0.00230233	0.00120199
c	1.3199	1.44165
d	N/A	1

Table of Data and Estimated Values of Interest

Dose	N	Observed mean	Estimated mean	Observed SD	Estimated SD	Scaled residuals
0	23	4.6	4.576	0.37	0.3538	0.3267
16.5	21	4.6	4.63	0.32	0.3538	-0.3947
168	20	5.05	5.045	0.32	0.3538	0.05759
1,570	17	6	6	0.44	0.3538	-0.003788

Likelihoods of Interest

Model	Log (likelihood)	Number of parameters	AIC
A1	43.80548	5	-77.61096
A2	45.09301	8	-74.18602
A3	43.80548	5	-77.61096
R	-5.569318	2	15.13864
4	43.67234	4	-79.34469

Tests of Interest

Test	-2*log (likelihood ratio)	Test df	p-value
Test 1	101.3	6	<0.0001
Test 2	2.575	3	0.4619
Test 3	2.575	3	0.4619
Test 6a	0.2663	1	0.6058

Table_Apx I-4. Summary of BMD modeling results for relative liver weight (g/100 g BW) in male CRL Sprague-Dawley rats exposed to HBCD by gavage for 13 weeks (WIL Research 2001); BMR = 10% RD from control mean and 1 SD change from control mean

Model ^a	Goodness of fit		BMD _{10RD} (mg/kg-d)	BMDL _{10RD} (mg/kg-d)	BMD _{1SD} (mg/kg-d)	BMDL _{1SD} (mg/kg-d)	Basis for model selection
	p-value	AIC					
Modeled with constant variance							No model showed adequate fit. Dropping highest dose is not expected to help in this case.
Exponential (M2) Exponential (M3) ^b	3.14 × 10 ⁻⁴	-67.830	328	283	269	219	
Exponential (M4) ^c	3.92 × 10 ⁻⁴	-69.396	164	97.7	128	77.9	
Exponential (M5) ^d	3.92 × 10 ⁻⁴	-69.396	164	97.7	128	77.9	
Hill	4.91 × 10 ⁻⁴	-69.815	145	74.8	113	59.7	
Power ^e Polynomial 3 ^{of} Polynomial 2 ^{og} Linear	5.14 × 10 ⁻⁴	-68.817	290	244	234	187	
Modeled with modeled variance							
Exponential (M2) Exponential (M3) ^b	0.00119	-68.721	337	295	320	245	
Exponential (M4) ^c	5.50 × 10 ⁻⁴	-68.244	204	103	187	67.5	
Exponential (M5) ^d	5.50 × 10 ⁻⁴	-68.244	204	103	187	67.5	
Hill	5.84 × 10 ⁻⁴	-68.355	192	35.9	173	106	
Power ^e Polynomial 3 ^{of} Polynomial 2 ^{og} Linear	0.00161	-69.324	299	256	282	210	

^aConstant variance (BMDS Test 2 p-value = 0.0644, BMDS Test 3 p-value = 0.0644) and nonconstant variance cases presented, no model was selected as a best-fitting model.

^bFor the Exponential (M3) model, the estimate of d was 1 (boundary). The models in this row reduced to the Exponential (M2) model.

^cThe Exponential (M4) model may appear equivalent to the Exponential (M5) model; however, differences exist in digits not displayed in the table.

^dThe Exponential (M5) model may appear equivalent to the Exponential (M4) model; however, differences exist in digits not displayed in the table.

^eFor the Power model, the power parameter estimate was 1. The models in this row reduced to the Linear model.

^fFor the Polynomial 3^o model, the b3 and b2 coefficient estimates were 0 (boundary of parameters space). The models in this row reduced to the Linear model.

^gFor the Polynomial 2^o model, the b2 coefficient estimate was 0 (boundary of parameters space). The models in this row reduced to the Linear model.

Table_Apx I-5. Summary of BMD modeling results for relative liver weight (g/100 g BW) in female CRL Sprague-Dawley rats exposed to HBCD by gavage for 13 weeks ([WIL Research 2001](#)); BMR = 10% RD from control mean and 1 SD change from control mean

Model ^a	Goodness of fit		BMD _{10RD} (mg/kg-d)	BMDL _{10RD} (mg/kg-d)	BMD _{1SD} (mg/kg-d)	BMDL _{1SD} (mg/kg-d)	Basis for model selection
	p-value	AIC					
Modeled with constant variance							No model showed adequate fit. Dropping highest dose is not expected to help in this case
Exponential (M2) Exponential (M3) ^b	<0.0001	-39.545	310	261	332	267	
Exponential (M4) Exponential (M5) ^c	2.59 × 10 ⁻⁴	-44.035	101	56.0	106	61.8	
Hill	5.71 × 10 ⁻⁴	-45.515	69.3	30.6	73.3	34.6	
Power ^d Polynomial 3 ^{°e} Polynomial 2 ^{°f} Linear	<0.0001	-40.679	270	220	287	226	
Modeled with modeled variance							
Exponential (M2) Exponential (M3) ^b	<0.0001	-38.793	319	269	374	282	
Exponential (M4) Exponential (M5) ^c	1.72 × 10 ⁻⁴	-42.217	53.4	28.5	38.3	16.0	
Hill	0.00115	-45.763	39.2	20.7	26.0	11.6	
Power ^d Polynomial 3 ^{°e} Polynomial 2 ^{°f} Linear	<0.0001	-39.727	278	227	327	237	

^aConstant variance (BMDS Test 2 *p*-value = 0.461, BMDS Test 3 *p*-value = 0.461) and nonconstant variance presented; no model was selected as a best-fitting model.

^bFor the Exponential (M3) model, the estimate of *d* was 1 (boundary). The models in this row reduced to the Exponential (M2) model.

^cFor the Exponential (M5) model, the estimate of *d* was 1 (boundary). The models in this row reduced to the Exponential (M4) model.

^dFor the Power model, the power parameter estimate was 1. The models in this row reduced to the Linear model.

^eFor the Polynomial 3[°] model, the *b*₃ and *b*₂ coefficient estimates were 0 (boundary of parameters space). The models in this row reduced to the Linear model.

^fFor the Polynomial 2[°] model, the *b*₂ coefficient estimate was 0 (boundary of parameters space). The models in this row reduced to the Linear model.

I.1.3 Reproductive Effects

Reduced Primordial Follicles

Table_Apx I-6. Summary of BMD modeling results for primordial follicles in F1 parental female CRL Sprague-Dawley rats exposed to HBCD by diet for 18 weeks ([Ema et al. 2008](#)); BMR = 1% RD from control mean, 5% RD from control mean, and 10% RD from control mean

Model ^a	Goodness of fit		BMD _{1RD} (mg/kg-d)	BMDL _{1RD} (mg/kg-d)	BMD _{5RD} (mg/kg-d)	BMDL _{5RD} (mg/kg-d)	BMD _{10RD} (mg/kg-d)	BMDL _{10RD} (mg/kg-d)	Basis for model selection
	p-value	AIC							
Exponential (M2) Exponential (M3) ^b	0.0130	408.57	26.8	13.9	137	71.0	281	146	Exponential M4 constant variance selected as only model with adequate fit.
Exponential (M4)	0.688	402.05	0.883	0.252	4.67	1.33	10.1	2.87	
Exponential (M5)	N/A ^c	403.91	4.09	0.259	8.23	1.37	11.4	2.95	
Hill	N/A ^c	403.91	8.00	error ^d	9.28	1.10	9.99	2.50	
Power ^e Polynomial 2 ^{of} Linear Polynomial 3 ^{og}	0.0117	408.78	33.1	19.8	165	99.0	331	198	

^aConstant variance case presented (BMDS Test 2 *p*-value = 0.242), selected model in bold; scaled residuals for selected model for doses 0, 9.6, 96.3, and 940.7 mg/kg-day were -0.129, 0.1915, -0.2611, and 0.1987, respectively.

^bFor the Exponential (M3) model, the estimate of *d* was 1 (boundary). The models in this row reduced to the Exponential (M2) model.

^cNo available degrees of freedom to calculate a goodness-of-fit value.

^dBMD or BMDL computation failed for this model.

^eFor the Power model, the power parameter estimate was 1. The models in this row reduced to the Linear model.

^fFor the Polynomial 2^o model, the b2 coefficient estimate was 0 (boundary of parameters space). The models in this row reduced to the Linear model.

^gThe Polynomial 3^o model may appear equivalent to the Linear model; however, differences exist in digits not displayed in the table.

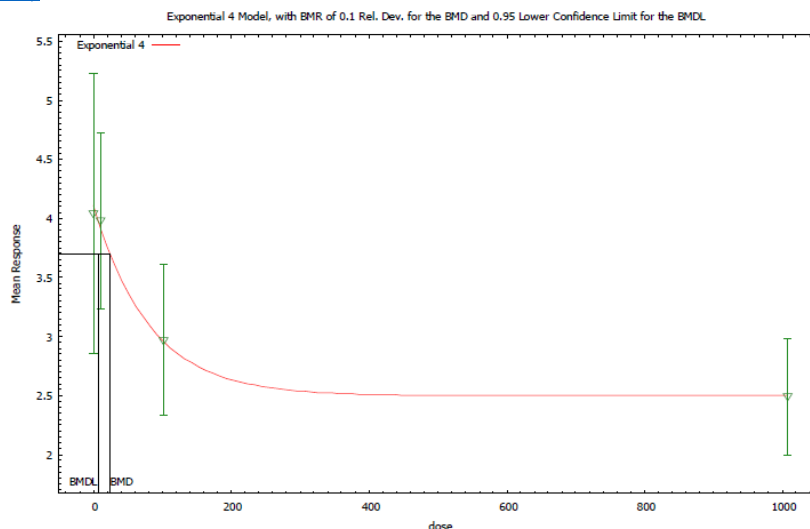
Data from [Ema et al. \(2008\)](#)

BMR = 10% RD from control mean; dose shown in mg/kg-day.

Figure_Apx I-3. Plot of mean response by dose, with fitted curve for Exponential M4, for primordial follicles in F1 parental female CRL Sprague-Dawley rats exposed to HBCD by diet for 18 weeks ([Ema et al. 2008](#)).

Exponential Model (Version: 1.9; Date: 01/29/2013)

The form of the response function is: $Y[\text{dose}] = a * [c - (c - 1) * \exp(-b * \text{dose})]$

A constant variance model is fit

Benchmark Dose Computation

BMR = 10% RD

BMD = 10.1143

BMDL at the 95% confidence level = 2.86589

Parameter Estimates

Variable	Estimate	Default initial parameter values
Inalpha	8.85121	8.84717
rho(S)	N/A	0
a	319.71	332.115
b	0.0301725	0.0026785
c	0.619779	0.567503
d	1	1

Table of Data and Estimated Values of Interest

Dose	N	Observed mean	Estimated mean	Observed SD	Estimated SD	Scaled residuals
0	10	316.3	319.7	119.5	83.56	-0.129
9.6	10	294.2	289.1	66.3	83.56	0.1915
96.3	10	197.9	204.8	76.9	83.56	-0.2611
940.7	10	203.4	198.1	79.5	83.56	0.1987

Likelihoods of Interest

Model	Log (likelihood)	Number of parameters	AIC
A1	-196.9435	5	403.8869
A2	-194.8505	8	405.701
A3	-196.9435	5	403.8869
R	-203.7104	2	411.4207
4	-197.0241	4	402.0483

Tests of Interest

Test	-2*log (likelihood ratio)	Test df	p-value
Test 1	17.72	6	0.006972
Test 2	4.186	3	0.2421
Test 3	4.186	3	0.2421
Test 6a	0.1613	1	0.6879

I.1.4 Developmental Effects**Offspring Loss**

Table_Apx I-7. Summary of BMD modeling results for offspring loss from PND 4 through PND 21 in F2 offspring CRL Sprague-Dawley rats; lactational doses of F1 dams (Ema et al. 2008); BMR = 1% ER and 5% ER

Model ^a	Goodness of Fit		BMD _{1ER} (mg/kg-d)	BMDL _{1ER} (mg/kg-d)	BMD _{5ER} (mg/kg-d)	BMDL _{5ER} (mg/kg-d)	Basis for model selection	
	p-value	AIC						
<i>Litter-specific covariate = implantation size; intra-litter correlations estimated</i>								
Nested Logistic	0.4417	561.04	20.4	10.1841	106.295	53.0644	Of the models that provided an adequate fit, a valid BMDL estimate and BMD/BMDL <5, the Nested Logistic model (litter-specific covariate not used; intra-litter correlations estimated) was selected based on lowest AIC (BMDLs differed by <3).	
NCTR	0.4114	561.816	25.079	12.5395	127.994	63.997		
Rai and Van Ryzin	0.4056	564.38	25.8561	1.00024	131.96	5.9492		
<i>Litter-specific covariate = implantation size; intra-litter correlations assumed to be zero</i>								
Nested Logistic	0.0000	643.52	36.1762	22.5296	188.497	117.391		
NCTR	0.0000	650.146	33.8744	16.9372	172.883	86.4414		
Rai and Van Ryzin	0.0000	660.111	35.975	17.9875	183.603	91.8017		
<i>Litter-specific covariate not used; intra-litter correlations estimated</i>								
Nested Logistic	0.3944	559.472	16.9114	9.03491	88.1172	47.0766		
NCTR ^b Rai and Van Ryzin	0.4051	560.38	25.8566	12.9283	131.963	65.9814		
<i>Litter-specific covariate not used; intra-litter correlations assumed to be zero</i>								
Nested Logistic	0.0000	654.556	26.3666	18.3313	137.384	95.5159		
NCTR ^b Rai and Van Ryzin	0.0000	656.111	35.975	17.9875	183.603	91.8017		

^aBecause the individual animal data were available, the BMDS nested models were fitted, with the selected model in bold. For the selected model, the proportion of litters with scaled residuals above 2 in absolute value for doses 0, 19.6, 179, and 1,724 mg/kg-d were 2/22, 0/22, 2/20, and 0/20, respectively.

^bWith the litter-specific covariate not used, the NCTR and Rai and van Ryzin models yielded identical results.

Data from [Ema et al. \(2008\)](#)

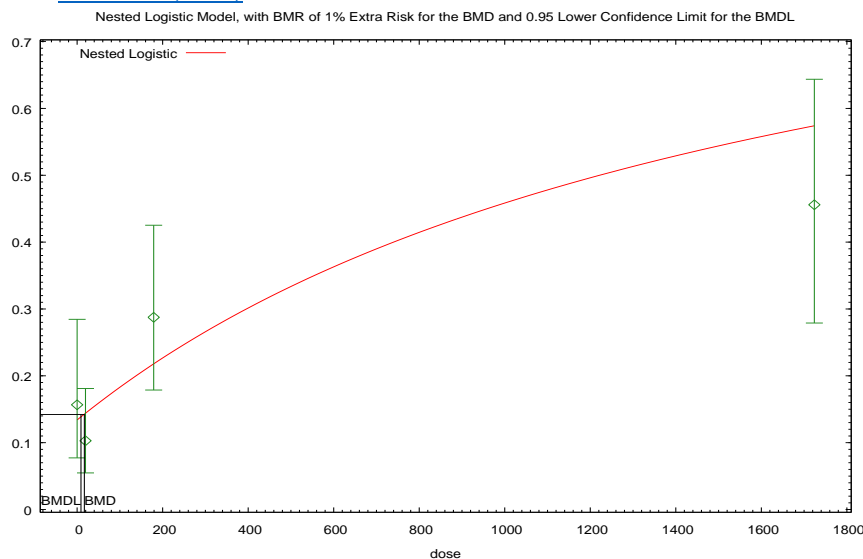

BMR = 1% ER; dose shown in mg/kg-day.

Figure_Apx I-4. Plot of incidence rate by dose, with fitted curve for the nested logistic model where the litter specific covariate was not used and the intra-litter correlations were estimated, for incidence of offspring loss from PND 4 through PND 21 in F2 offspring CRL Sprague-Dawley rats; lactational doses of F1 dams ([Ema et al. 2008](#)).

Nested Logistic Model (Version: 2.20; Date: 04/27/2015)

The form of the probability function is:

$$\text{Prob.} = \alpha + \theta_1 * R_{ij} + [1 - \alpha - \theta_1 * R_{ij}] / [1 + \exp(-\beta - \theta_2 * R_{ij} - \rho * \log(\text{Dose}))],$$

where R_{ij} is the litter specific covariate.

Restrict Power $\rho \geq 1$.

Benchmark Dose Computation

To calculate the BMD and BMDL, the litter specific covariate is fixed at the mean litter specific covariate of all the data: 14.654762

BMR = 1% ER

BMD = 16.9114

BMDL at the 95% confidence level = 9.03491

Parameter Estimates

Variable	Estimate	(Default) Initial Parameter Values
Alpha	0.133513	0.133513
Beta	-7.42311	-7.42311
Rho	1	1

phi1	0.229222	0.229222
phi2	0.152985	0.152985
phi3	0.247495	0.247495
phi4	0.586386	0.586386

Log-likelihood: -273.736 AIC: 559.472

Goodness-of-Fit Table

Dose	Lit.-Spec.		Litter		Scaled		Residual
	Cov.	Est.	Prob.	Size	Expected	Observed	
0.0000	9.0000	0.134	6	0.801	0	-0.6563	
0.0000	10.0000	0.134	6	0.801	1	0.1630	
0.0000	11.0000	0.134	8	1.068	0	-0.6880	
0.0000	11.0000	0.134	6	0.801	0	-0.6563	
0.0000	12.0000	0.134	8	1.068	1	-0.0439	
0.0000	13.0000	0.134	8	1.068	6	3.1766	
0.0000	13.0000	0.134	8	1.068	0	-0.6880	
0.0000	13.0000	0.134	8	1.068	3	1.2443	
0.0000	13.0000	0.134	8	1.068	0	-0.6880	
0.0000	14.0000	0.134	8	1.068	1	-0.0439	
0.0000	14.0000	0.134	8	1.068	0	-0.6880	
0.0000	15.0000	0.134	4	0.534	0	-0.6043	
0.0000	16.0000	0.134	8	1.068	1	-0.0439	
0.0000	16.0000	0.134	8	1.068	1	-0.0439	
0.0000	16.0000	0.134	8	1.068	0	-0.6880	
0.0000	16.0000	0.134	8	1.068	2	0.6002	
0.0000	16.0000	0.134	8	1.068	1	-0.0439	
0.0000	16.0000	0.134	8	1.068	4	1.8884	
0.0000	17.0000	0.134	8	1.068	0	-0.6880	
0.0000	17.0000	0.134	8	1.068	0	-0.6880	
0.0000	17.0000	0.134	8	1.068	5	2.5325	
0.0000	18.0000	0.134	8	1.068	0	-0.6880	
19.6000	12.0000	0.144	7	1.005	2	0.7747	
19.6000	13.0000	0.144	8	1.148	1	-0.1039	
19.6000	13.0000	0.144	8	1.148	0	-0.8046	
19.6000	13.0000	0.144	8	1.148	3	1.2975	
19.6000	14.0000	0.144	8	1.148	2	0.5968	
19.6000	14.0000	0.144	8	1.148	0	-0.8046	
19.6000	14.0000	0.144	8	1.148	0	-0.8046	
19.6000	14.0000	0.144	8	1.148	0	-0.8046	
19.6000	14.0000	0.144	8	1.148	0	-0.8046	
19.6000	15.0000	0.144	8	1.148	1	-0.1039	
19.6000	15.0000	0.144	8	1.148	3	1.2975	
19.6000	15.0000	0.144	8	1.148	0	-0.8046	
19.6000	15.0000	0.144	8	1.148	1	-0.1039	
19.6000	16.0000	0.144	8	1.148	0	-0.8046	
19.6000	16.0000	0.144	8	1.148	0	-0.8046	
19.6000	16.0000	0.144	8	1.148	0	-0.8046	
19.6000	16.0000	0.144	8	1.148	0	-0.8046	
19.6000	17.0000	0.144	8	1.148	1	-0.1039	
19.6000	17.0000	0.144	8	1.148	0	-0.8046	
19.6000	17.0000	0.144	8	1.148	3	1.2975	
19.6000	18.0000	0.144	8	1.148	1	-0.1039	
19.6000	21.0000	0.144	8	1.148	0	-0.8046	

179.0000	11.0000	0.217	8	1.738	4	1.1735
179.0000	11.0000	0.217	8	1.738	2	0.1361
179.0000	12.0000	0.217	8	1.738	2	0.1361
179.0000	13.0000	0.217	8	1.738	0	-0.9013
179.0000	14.0000	0.217	8	1.738	2	0.1361
179.0000	14.0000	0.217	8	1.738	5	1.6922
179.0000	14.0000	0.217	8	1.738	3	0.6548
179.0000	14.0000	0.217	8	1.738	1	-0.3826
179.0000	14.0000	0.217	8	1.738	4	1.1735
179.0000	14.0000	0.217	8	1.738	1	-0.3826
179.0000	14.0000	0.217	8	1.738	6	2.2109
179.0000	15.0000	0.217	8	1.738	0	-0.9013
179.0000	15.0000	0.217	8	1.738	0	-0.9013
179.0000	15.0000	0.217	8	1.738	1	-0.3826
179.0000	15.0000	0.217	8	1.738	6	2.2109
179.0000	16.0000	0.217	8	1.738	0	-0.9013
179.0000	16.0000	0.217	8	1.738	4	1.1735
179.0000	17.0000	0.217	8	1.738	0	-0.9013
179.0000	17.0000	0.217	8	1.738	0	-0.9013
179.0000	19.0000	0.217	8	1.738	5	1.6922

1,724.0000	10.0000	0.573	8	4.585	4	-0.1850
1,724.0000	11.0000	0.573	8	4.585	2	-0.8178
1,724.0000	12.0000	0.573	8	4.585	1	-1.1341
1,724.0000	12.0000	0.573	6	3.439	0	-1.4313
1,724.0000	13.0000	0.573	4	2.292	1	-0.7865
1,724.0000	14.0000	0.573	8	4.585	8	1.0805
1,724.0000	14.0000	0.573	8	4.585	1	-1.1341
1,724.0000	14.0000	0.573	8	4.585	0	-1.4505
1,724.0000	14.0000	0.573	4	2.292	4	1.0392
1,724.0000	15.0000	0.573	7	4.012	3	-0.3637
1,724.0000	15.0000	0.573	8	4.585	0	-1.4505
1,724.0000	15.0000	0.573	6	3.439	6	1.0662
1,724.0000	15.0000	0.573	4	2.292	4	1.0392
1,724.0000	16.0000	0.573	1	0.573	1	0.8631
1,724.0000	16.0000	0.573	8	4.585	5	0.1313
1,724.0000	16.0000	0.573	8	4.585	0	-1.4505
1,724.0000	17.0000	0.573	8	4.585	3	-0.5014
1,724.0000	17.0000	0.573	8	4.585	8	1.0805
1,724.0000	17.0000	0.573	8	4.585	3	-0.5014
1,724.0000	20.0000	0.573	8	4.585	8	1.0805

Observed Chi-square = 86.7400 Bootstrap Iterations per run = 10,000
p-value = 0.3944

Reduced Pup Body Weight**Table_Apx I-8. Summary of BMD modeling results for pup weight during lactation in F2 male offspring CRL Sprague-Dawley rats (PND 21) exposed to HBCD by diet for 3 weeks, lactational dose (Ema et al. 2008); BMR = 5% RD from control mean, 10% RD from control mean, 0.5 SD change from control mean, and 1 SD change from control mean**

Model ^a	Goodness of fit		BMD _{5RD} (mg/kg-d)	BMDL _{5RD} (mg/kg-d)	BMD _{10RD} (mg/kg-d)	BMDL _{10RD} (mg/kg-d)	Basis for model selection
	p-value	AIC					
Exponential (M2)	0.486	420.90	354	240	727	494	Of the models that provided an adequate fit, a valid BMDL estimate and BMD/BMDL <5, the Exponential M4 constant variance model was selected based on lowest BMDL (BMDLs differed by >3).
Exponential (M3)	0.266	422.69	651	244	1016	500	
Exponential (M4)	0.486	420.90	354	89.6	727	206	
Exponential (M5)	N/A ^b	424.68	230	94.0	258	181	
Hill	N/A ^b	424.68	230	89.2	264	error ^c	
Power	0.266	422.69	676	282	1,049	565	
Polynomial 3° Polynomial 2°	0.264	422.70	817	282	1,161	564	
Linear	0.497	420.85	389	280	779	560	
Model ^a	Goodness of fit		BMD _{0.5SD} (mg/kg-d)	BMDL _{0.5SD} (mg/kg-d)	BMD _{1SD} (mg/kg-d)	BMDL _{1SD} (mg/kg-d)	
	p-value	AIC					
Exponential (M2)	0.486	420.90	634	419	1,332	879	
Exponential (M3)	0.266	422.69	937	425	1,483	891	
Exponential (M4)	0.486	420.90	634	172	1,332	468	
Exponential (M5)	N/Ab	424.68	252	176	296	189	
Hill	N/Ab	424.68	256	176	324	error ^c	
Power	0.266	422.69	969	482	1,503	965	
Polynomial 3° Polynomial 2°	0.264	422.70	1,091	482	1,549	964	
Linear	0.497	420.85	684	478	1,368	956	

^aConstant variance case presented (BMDS Test 2 p-value = 0.0278), selected model in bold; scaled residuals for selected model for doses 0, 19.6, 179, and 1,724 mg/kg-day were -0.92, 0.71, 0.27, and -0.06, respectively.

^bNo available degrees of freedom to calculate a goodness-of-fit value.

^cBMD or BMDL computation failed for this model.

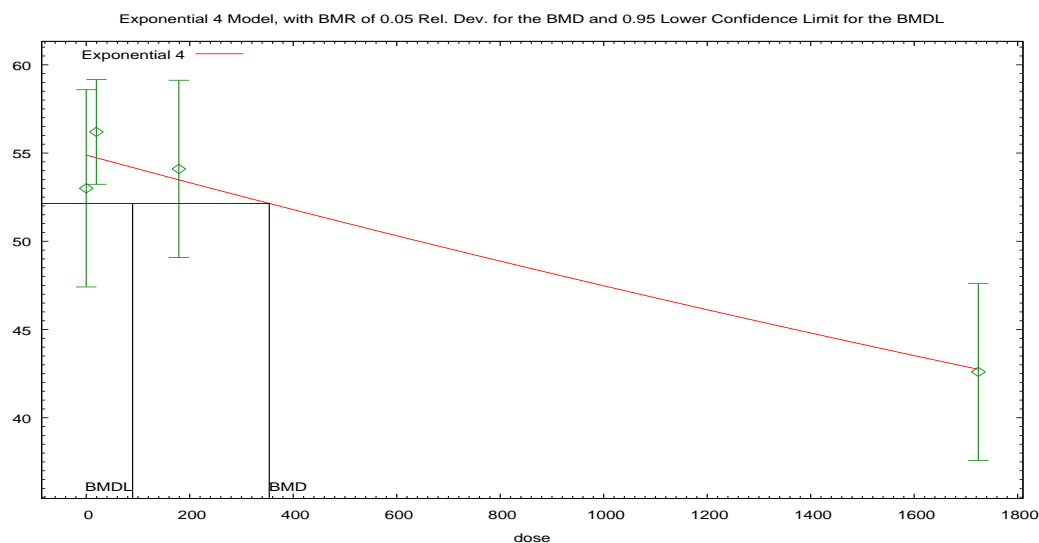

BMR = 5% RD from control mean; dose shown in mg/kg-day.

Figure_Apx I-5. Plot of mean response by dose with fitted curve for Exponential (M4) model with constant variance for pup weight during lactation in F2 male offspring CRL Sprague-Dawley rats (PND 21) exposed to HBCD by diet multigenerationally, lactational dose ([Ema et al. 2008](#)).

Exponential Model (Version: 1.10; Date: 01/12/2015)

The form of the response function is: $Y[\text{dose}] = a * [c - (c - 1) * \exp(-b * \text{dose})]$

A constant variance model is fit

Benchmark Dose Computation

BMR = 5% RD

BMD = 353.728

BMDL at the 95% confidence level = 89.5935

Parameter Estimates

Variable	Estimate	Default initial parameter values
Inalpha	4.53195	4.51269
rho	N/A	0
a	54.8883	59.01
b	0.000145008	0.00128594
c	0	0.687535
d	N/A	1

Table of Data and Estimated Values of Interest

Dose	N	Observed mean	Estimated mean	Observed SD	Estimated SD	Scaled residuals
0	22	53	54.89	12.6	9.64	-0.9187
19.6	22	56.2	54.73	6.7	9.64	0.714
179	18	54.1	53.48	10.1	9.64	0.272
1,724	13	42.6	42.75	8.3	9.64	-0.0551

Likelihoods of Interest

Model	Log (likelihood)	Number of parameters	AIC
A1	-206.7258	5	423.4517
A2	-202.1665	8	420.333
A3	-206.7258	5	423.4517
R	-214.7267	2	433.4535
4	-207.4482	3	420.8963

Tests of Interest

Test	-2*log (likelihood ratio)	Test df	p-value
Test 1	25.12	6	0.0003244
Test 2	9.119	3	0.02775
Test 3	9.119	3	0.02775
Test 6a	1.445	2	0.4856

Delayed Eye Opening

The benchmark dose (BMD) modeling of nested dichotomous data was conducted with the EPA's BMD software (BMDS version 3.11). The only model currently available in the software for use with nested data is the nested logistic model. The nested logistic model was applied to the both male and female F2 pup eye opening datasets with and without a litter specific covariate to account for intra-litter similarity (litter effects) based on non-treatment-related condition and with and without modeling of intra-litter correlation to account for intra-litter similarity based on treatment-related effects in the two-generation reproduction study. The number of implantations in F1 dams was found to not vary with treatment and was therefore used as the litter-specific covariate for the modeling of the F2 pup eye opening (Table_Apx I-9). F1 dam GD0 body weight, F2 pup PND4 viability index, and F2 pup PND21 viability index were also considered as litter-specific covariates. However, all these endpoints were affected by treatment at the highest dose, and therefore, not suitable for use as a covariate.

Because BMDS can only model increasing dose-response trends for quantal data, the data were inverted for modeling, as per the following example: 4 open/4 total (100%) -> 0 not open/4 total (0%).

Table_Apx I-9. Effect of Dose on Potential Litter-Specific Covariates

Dose (mg/kg-day)	F1 dam GD0 BW (g)	F2 pup PND4 viability index (%)	F2 pup PND21 viability index (%)	F1 dam implants
0	297.7±28.1 (23) ^a	86.9±24.8 (23)	85.0±22.0 (22)	14.3±2.5 (23)
15	299.3±20.6 (23)	87.3±21.1 (23)	89.6±13.9 (22)	14.7±3.4 (23)
139	290.2±19.6 (21)	92.1±12.8 (20)	71.3±26.9 (20)	14.0±3.2 (21)
1360	272.9±22.2 (21)**	68.4±33.5 (21)*	49.7±41.1 (20)**	14.3±2.8 (21)

^aMean ± standard deviation (n)

*Statistically significant difference reported by study authors (p<0.05); **(p<0.01)

Female Offspring

Results for the F2 female pups are shown in Table_Apx I-10. Significant model fit ($p > 0.1$) was achieved only when intra-litter correlation was modeled. With intra-litter correlation included in the model, inclusion of the covariate (number of implantations) in the model increased model fit slightly ($p = 0.53$ vs $p = 0.49$), but not enough to justify inclusion of the extra parameters in the model, as shown by the lower AIC when the covariate was not modeled (270.4 vs 272.8). BMDLs were sufficiently close (<3-fold difference), so model selection was based on AIC. The selected model (lowest AIC) included parameters for intra-litter correlation but not for the covariate. Visual inspection of model fit and review of scaled residuals confirmed adequate fit of the selected model to the data. Modeling was performed using BMR = 10% or 5% extra risk. For both BMRs, the BMD results for the female pups are within the range of observation (15-1360 mg/kg-day), and the BMDL results reflect acceptable levels of uncertainty (BMD/BMDL ratio ~2.6). For comparison to the BMDL values in Table_Apx I-10, the NOAEL and LOAEL values for this endpoint were 15 and 139 mg/kg-day, respectively, based on statistical significance.

Table_Apx I-10. Summary of BMD modeling results for delayed eye opening F2 female offspring CRL Sprague-Dawley rats (PND 14); F2 generation doses (Ema et al. 2008); BMR = 5% ER and 10% ER

Model ^a	Goodness of Fit		BMD _{5ER} (mg/kg-d)	BMDL _{5ER} (mg/kg-d)	BMD _{10ER} (mg/kg-d)	BMDL _{10ER} (mg/kg-d)	Basis for model selection	
	p-value	AIC						
<i>Litter-specific covariate = implantation size; intra-litter correlations estimated</i>								
Nested Logistic	0.5286	272.82	69.65	27.49	147.05	58.03	Of the models that provided an adequate fit, a valid BMDL estimate and BMD/BMDL <5, the Nested Logistic model with litter-specific covariate not used and intra-litter correlations estimated was selected based on lowest AIC (BMDLs differed by <3).	
<i>Litter-specific covariate = implantation size; intra-litter correlations assumed to be zero</i>								
Nested Logistic	<0.0001	302.36	57.77	29.62	121.97	62.53		
<i>Litter-specific covariate not used; intra-litter correlations estimated</i>								
Nested Logistic	0.4893	270.44	75.61	28.73	159.62	60.66		
<i>Litter-specific covariate not used; intra-litter correlations assumed to be zero</i>								
Nested Logistic	<0.0001	300.89	61.03	30.31	300.89	128.84		

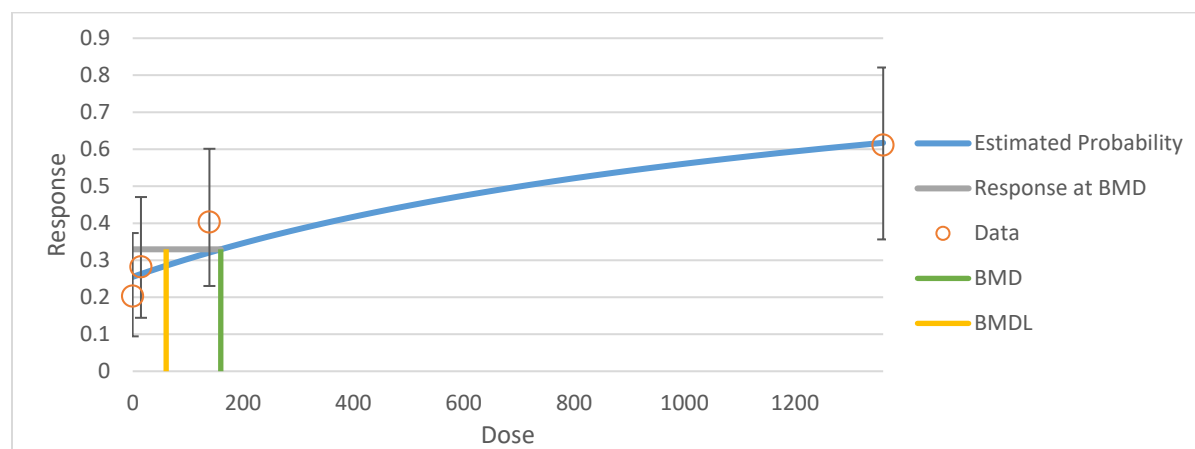

BMR = 10% RD from control mean; dose shown in mg/kg-day.

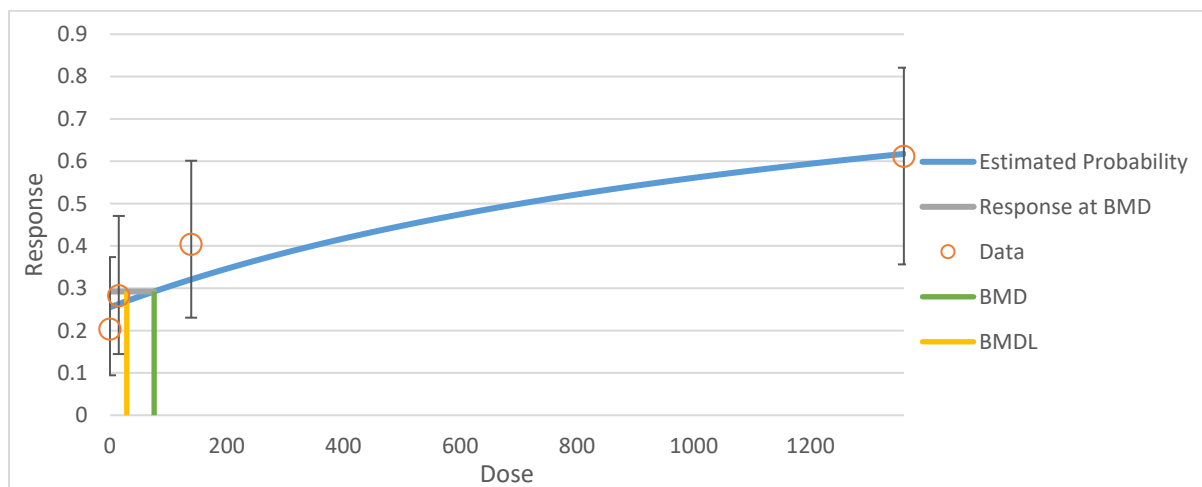

BMR = 5% RD from control mean; dose shown in mg/kg-day.

Figure_Apx I-6 and Figure_Apx I-7. Plot of mean response by dose with fitted curve for Frequentist Nested Logistic Model without litter-specific covariate and with intra-litter correlation; and 0.95 Lower Confidence Limit for the BMDL in F2 female offspring CRL Sprague-Dawley rats (PND 14) exposed to HBCD multigenerationally (Ema et al. 2008). Plots display results for BMRs of 10% and 5% ER, respectively.

Male Offspring

Results for the F2 male pups are shown in Table_Apx I-11. Significant model fit ($p > 0.1$) was achieved only when intra-litter correlation was modeled. With intra-litter correlation included in the model, inclusion of the covariate (number of implantations) in the model increased model fit slightly and slightly lowered the AIC (274.3 vs 274.4). BMDLs were sufficiently close (<3-fold difference), so initial model selection was based on AIC. The model with lowest AIC included parameters for intra-litter correlation and for the covariate. Review of scaled residuals confirmed adequate fit of this model to the data, but visual inspection showed that model fit was problematic, with the lower doses not influencing the shape and the high dose having outsized influence. Modeling was performed using BMR = 10% or 5% extra risk. For both BMRs, the BMD results for the male pups are within the range of observation, but the BMDL results reflect very high levels of uncertainty in the modeling results (BMD/BMDL ratio = 16-31). Log transformation of the doses produced a curve that appeared visually to better fit the data, but p-value was not improved, and associated BMDs were below the range of observation. Dropping the high dose was considered but not done because the only statistically significant change was at the high dose. For comparison to the BMDL values in Table_Apx I-11, the NOAEL and LOAEL values for this endpoint were 139 and 1360 mg/kg-day, respectively, based on statistical significance.

Table_Apx I-11. Summary of BMD modeling results for delayed eye opening F2 female offspring CRL Sprague-Dawley rats (PND 14); F2 generation doses (Ema et al. 2008); BMR = 5% ER and 10% ER

Model ^a	Goodness of Fit		BMD _{5ER} (mg/kg-d)	BMDL _{5ER} (mg/kg-d)	BMD _{10ER} (mg/kg-d)	BMDL _{10ER} (mg/kg-d)	Basis for model selection
	p-value	AIC					
<i>Litter-specific covariate = implantation size; intra-litter correlations estimated</i>							No model selected due to high uncertainty in modeling results, as indicated by BMD/ BMDL ratio = 16-36 and poor visual fit for models with adequate statistical fit (p>0.1).
Nested Logistic	0.5223	274.29	842.06	27.50	954.73	58.05	
<i>Litter-specific covariate = implantation size; intra-litter correlations assumed to be zero</i>							
Nested Logistic	<0.0001	315.88	58.68	28.39	123.87	59.94	
<i>Litter-specific covariate not used; intra-litter correlations estimated</i>							
Nested Logistic	0.5220	274.37	917.36	25.30	1031.43	53.42	
<i>Litter-specific covariate not used; intra-litter correlations assumed to be zero</i>							
Nested Logistic	<0.0001	317.48	74.46	34.00	157.19	71.79	

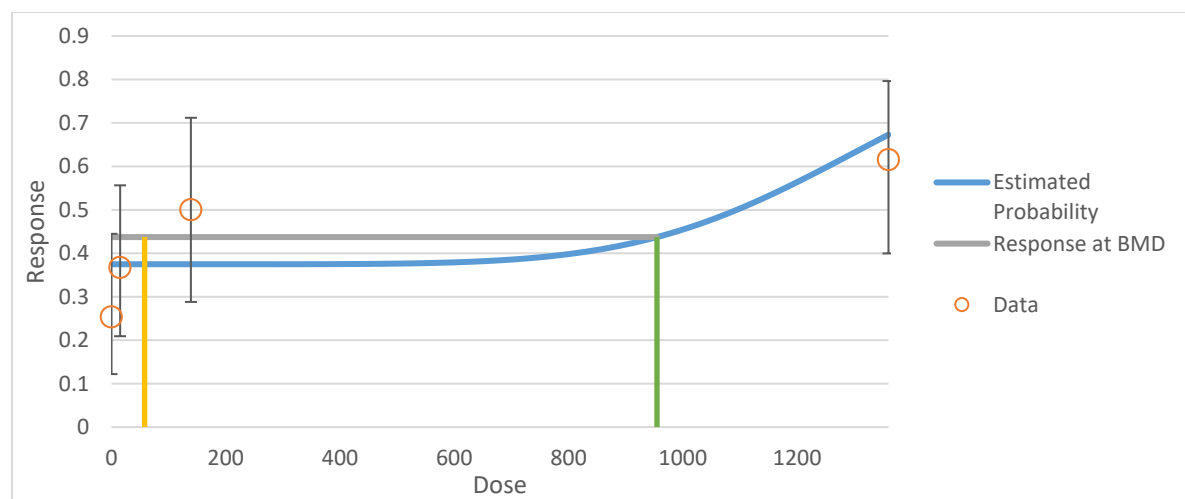

BMR = 10% RD from control mean; dose shown in mg/kg-day.

Figure_Apx I-8. Plot of mean response by dose with fitted curve for Frequentist Nested Logistic Model without litter-specific covariate and with intra-litter correlation; and 0.95 Lower Confidence Limit for the BMDL in F2 male offspring CRL Sprague-Dawley rats (PND 14) exposed to HBCD multigenerationally (Ema et al. 2008). Plot displays results for BMRs of 10% and 5% ER.

Appendix J ENVIRONMENTAL RISK

J.1 Aquatic Environment

J.1.1 Risk Quotients based on a Production Volume of 100,000 lbs/yr and 0% Removal from Direct Releases

J.1.1.1 E-FAST Initial Screening for Surface Water Concentrations

Table_Apx J-1. Calculated Risk Quotients based on Estimated HBCD Surface Water Concentrations (µg/L) Using E-FAST (0% Removal)

The bolded and gray highlighted values denote a risk (RQ≥1) to the aquatic environment where the surface water concentration (SWC) exceeds the concentration of concern (COC) for acute, algae or chronic environmental hazard. Underlined SWCs indicate when the predicted surface water release of HBCD for a sub-scenario exceeds the water solubility of HBCD (66 µg/L), resulting in acute, algae or chronic RQs greater than 165, 66, and 158.3, respectively.										
Exposure Scenario	Sub-Scenario	Days of Release	10th Percentile 7Q10				50th percentile: 7Q10			
			SWC (µg/L)	Acute RQ (COC: 0.4 µg/L)	Chronic RQ (COC: 0.417 µg/L)	Algae RQ (COC: 1 µg/L)	SWC (µg/L)	Acute RQ (COC: 0.4 µg/L)	Chronic RQ (COC: 0.417 µg/L)	Algae RQ (COC: 1 µg/L)
Section 2.4.1.2 – Repackaging of Import Containers (1)	1.1	29	19.45	48.63	46.64	19.45	0.39	0.98	0.94	0.39
	1.2	300	1.87	4.68	4.48	1.87	0.04	0.09	0.09	0.04
	1.3	29	<u>97.51</u>	243.78	233.84	97.51	1.94	4.85	4.65	1.94
	1.4	300	9.43	23.58	22.61	9.43	0.19	0.48	0.46	0.19
	1.5	29	20.10	50.25	48.20	20.10	2.00	5.00	4.80	2.00
	1.6	300	1.93	4.83	4.63	1.93	0.19	0.48	0.46	0.19
	1.7	29	<u>100.77</u>	251.93	241.65	100.77	10.00	25.00	23.98	10.00
	1.8	300	9.74	24.35	23.36	9.74	0.97	2.43	2.33	0.97
Section 2.4.1.3 – Compounding of Polystyrene Resin to Produce XPS Masterbatch (2)	2.1	10	18.70	46.75	44.84	18.70	0.37	0.93	0.89	0.37
	2.2	60	3.04	7.60	7.29	3.04	0.06	0.15	0.15	0.06
	2.3	10	42.02	105.05	100.77	42.02	0.84	2.10	2.01	0.84
	2.4	60	7.00	17.50	16.79	7.00	0.14	0.35	0.34	0.14
	2.5	10	1.87	4.68	4.48	1.87	0.04	0.09	0.09	0.04

The bolded and gray highlighted values denote a risk (RQ≥1) to the aquatic environment where the surface water concentration (SWC) exceeds the concentration of concern (COC) for acute, algae or chronic environmental hazard. Underlined SWCs indicate when the predicted surface water release of HBCD for a sub-scenario exceeds the water solubility of HBCD (66 µg/L), resulting in acute, algae or chronic RQs greater than 165, 66, and 158.3, respectively.										
Exposure Scenario	Sub-Scenario	Days of Release	10th Percentile 7Q10				50th percentile: 7Q10			
			SWC (µg/L)	Acute RQ (COC: 0.4 µg/L)	Chronic RQ (COC: 0.417 µg/L)	Algae RQ (COC: 1 µg/L)	SWC (µg/L)	Acute RQ (COC: 0.4 µg/L)	Chronic RQ (COC: 0.417 µg/L)	Algae RQ (COC: 1 µg/L)
	2.6	60	0.30	0.75	0.72	0.30	0.01	0.02	0.01	0.01
	2.7	10	4.20	10.50	10.07	4.20	0.08	0.21	0.20	0.08
	2.8	60	0.70	1.75	1.68	0.70	0.01	0.03	0.03	0.01
	2.9	10	1.93	4.83	4.63	1.93	0.19	0.48	0.46	0.19
	2.10	60	0.31	0.78	0.74	0.31	0.03	0.08	0.07	0.03
	2.11	10	4.34	10.85	10.41	4.34	0.43	1.08	1.03	0.43
	2.12	60	0.72	1.80	1.73	0.72	0.07	0.18	0.17	0.07
Section 2.4.1.4 – Processing of HBCD to produce XPS Foam using XPS Masterbatch (3)	3.1	1	60.60	151.50	145.32	60.60	1.20	3.00	2.88	1.20
	3.2	15	4.04	10.10	9.69	4.04	0.08	0.20	0.19	0.08
	3.3	1	<u>148.38</u>	370.95	355.83	148.38	2.95	7.38	7.07	2.95
	3.4	15	9.98	24.95	23.93	9.98	0.20	0.50	0.48	0.20
	3.5	1	6.06	15.15	14.53	6.06	0.12	0.30	0.29	0.12
	3.6	15	0.40	1.01	0.97	0.40	0.01	0.02	0.02	0.01
	3.7	1	14.84	37.10	35.58	14.84	0.30	0.74	0.71	0.30
	3.8	15	1.00	2.50	2.39	1.00	0.02	0.05	0.05	0.02
	3.9	1	6.26	15.66	15.02	6.26	0.62	1.56	1.49	0.62
	3.10	15	0.42	1.05	1.00	0.42	0.04	0.10	0.10	0.04
	3.11	1	15.34	38.34	36.77	15.34	1.52	3.81	3.65	1.52
	3.12	15	1.03	2.58	2.47	1.03	0.10	0.25	0.24	0.10
Section 2.2.5 – Processing of HBCD to produce XPS Foam using HBCD Powder (4)	4.1	1	57.73	144.33	138.44	57.73	1.15	2.88	2.76	1.15
	4.2	12	4.86	12.15	11.65	4.86	0.10	0.24	0.23	0.10
	4.3	1	5.77	14.43	13.84	5.77	0.12	0.29	0.28	0.12
	4.4	12	0.49	1.22	1.17	0.49	0.01	0.02	0.02	0.01

The bolded and gray highlighted values denote a risk (RQ≥1) to the aquatic environment where the surface water concentration (SWC) exceeds the concentration of concern (COC) for acute, algae or chronic environmental hazard. Underlined SWCs indicate when the predicted surface water release of HBCD for a sub-scenario exceeds the water solubility of HBCD (66 µg/L), resulting in acute, algae or chronic RQs greater than 165, 66, and 158.3, respectively.										
Exposure Scenario	Sub-Scenario	Days of Release	10th Percentile 7Q10				50th percentile: 7Q10			
			SWC (µg/L)	Acute RQ (COC: 0.4 µg/L)	Chronic RQ (COC: 0.417 µg/L)	Algae RQ (COC: 1 µg/L)	SWC (µg/L)	Acute RQ (COC: 0.4 µg/L)	Chronic RQ (COC: 0.417 µg/L)	Algae RQ (COC: 1 µg/L)
	4.5	1	5.97	14.93	14.32	5.97	0.59	1.48	1.41	0.59
	4.6	12	0.50	1.25	1.20	0.50	0.05	0.12	0.12	0.05
Section 2.4.1.6 – Processing of HBCD to produce EPS Foam from Imported EPS Resin Beads (5)	5.1	16	<u>3881.55</u>	9703.88	9308.27	3881.55	<u>77.16</u>	192.90	185.04	77.16
	5.2	16	<u>388.16</u>	970.39	930.83	388.16	7.72	19.29	18.50	7.72
	5.3	16	<u>401.16</u>	1002.90	962.01	401.16	39.82	99.55	95.49	39.82
	5.4	140	<u>444.39</u>	1110.98	1065.68	444.39	8.83	22.08	21.18	8.83
	5.5	140	44.44	111.10	106.57	44.44	0.88	2.21	2.12	0.88
	5.6	140	45.93	114.83	110.14	45.93	4.56	11.40	10.94	4.56
	5.7	16	<u>5295.51</u>	13238.78	12699.06	5295.51	<u>105.26</u>	263.15	252.42	105.26
	5.8	16	<u>529.55</u>	1323.88	1269.91	529.55	10.53	26.32	25.24	10.53
	5.9	16	<u>547.29</u>	1368.23	1312.45	547.29	54.32	135.80	130.26	54.32
	5.10	140	<u>605.99</u>	1514.98	1453.21	605.99	12.05	30.13	28.90	12.05
	5.11	140	60.60	151.50	145.32	60.60	1.21	3.01	2.89	1.21
5.12	140	62.63	156.58	150.19	62.63	6.22	15.55	14.92	6.22	
Section 2.4.1.7 – Processing of HBCD to produce SIPs and Automobile Replacement Parts from XPS/EPS Foam (6)	6.1	16	17.83	44.58	42.76	17.83	0.35	0.88	0.84	0.35
	6.2	16	1.78	4.46	4.28	1.78	0.04	0.09	0.08	0.04
	6.3	16	1.84	4.60	4.41	1.84	0.18	0.45	0.43	0.18
	6.4	300	0.95	2.38	2.28	0.95	0.02	0.05	0.05	0.02
	6.5	300	0.10	0.24	0.23	0.10	0.00	0.00	0.00	0.00
	6.6	300	0.10	0.25	0.24	0.10	0.01	0.02	0.02	0.01
	6.7	16	<u>79.60</u>	199.00	190.89	79.60	1.60	4.00	3.84	1.60
	6.8	16	7.96	19.90	19.09	7.96	0.16	0.40	0.38	0.16
	6.9	16	8.25	20.63	19.78	8.25	0.82	2.05	1.97	0.82

The bolded and gray highlighted values denote a risk (RQ≥1) to the aquatic environment where the surface water concentration (SWC) exceeds the concentration of concern (COC) for acute, algae or chronic environmental hazard. Underlined SWCs indicate when the predicted surface water release of HBCD for a sub-scenario exceeds the water solubility of HBCD (66 µg/L), resulting in acute, algae or chronic RQs greater than 165, 66, and 158.3, respectively.										
Exposure Scenario	Sub-Scenario	Days of Release	10th Percentile 7Q10				50th percentile: 7Q10			
			SWC (µg/L)	Acute RQ (COC: 0.4 µg/L)	Chronic RQ (COC: 0.417 µg/L)	Algae RQ (COC: 1 µg/L)	SWC (µg/L)	Acute RQ (COC: 0.4 µg/L)	Chronic RQ (COC: 0.417 µg/L)	Algae RQ (COC: 1 µg/L)
	6.10	300	4.20	10.50	10.07	4.20	0.08	0.21	0.20	0.08
	6.11	300	0.42	1.05	1.01	0.42	0.01	0.02	0.02	0.01
	6.12	300	0.44	1.10	1.06	0.44	0.04	0.11	0.10	0.04
Section 2.4.1.9 – Installation of XPS/EPS Foam Insulation in Residential, Public, and Commercial Buildings, and Other Structures (8)	8.1	1	0.80	2.00	1.92	0.80	0.03	0.08	0.08	0.03
	8.2	1	0.08	0.20	0.19	0.08	0.00	0.01	0.01	0.00
	8.3	3	<u>94.00</u>	235.00	225.42	94.00	3.70	9.25	8.87	3.70
	8.4	3	9.40	23.50	22.54	9.40	0.37	0.93	0.89	0.37
Section 2.4.1.10 – Demolition of XPS/EPS Foam Insulation Products in Residential, Public and Commercial Buildings, and Other Structures (9)	9.1	1	0.71	1.78	1.70	0.71	0.03	0.07	0.07	0.03
	9.2	1	0.07	0.18	0.17	0.07	0.00	0.01	0.01	0.00
	9.3	3	<u>636.79</u>	1591.98	1527.07	636.79	25.19	62.98	60.41	25.19
	9.4	3	63.68	159.20	152.71	63.68	2.52	6.30	6.04	2.52
Section 2.4.1.11 – Recycling of EPS Foam and Reuse of XPS Foam (10)	10.1	1	<u>83.14</u>	207.85	199.38	83.14	1.65	4.13	3.96	1.65
	10.2	1	8.31	20.79	19.94	8.31	0.17	0.41	0.40	0.17
	10.3	1	8.59	21.48	20.60	8.59	0.85	2.13	2.04	0.85
	10.4	140	0.59	1.48	1.41	0.59	0.01	0.03	0.03	0.01
	10.5	140	0.06	0.15	0.14	0.06	0.00	0.00	0.00	0.00
	10.6	140	0.06	0.15	0.15	0.06	0.01	0.02	0.01	0.01
	10.7	1	<u>99.00</u>	247.50	237.41	99.00	1.97	4.93	4.72	1.97
	10.8	1	9.90	24.75	23.74	9.90	0.20	0.49	0.47	0.20
	10.9	1	10.23	25.58	24.53	10.23	1.02	2.55	2.45	1.02
	10.10	140	0.71	1.77	1.70	0.71	0.01	0.04	0.03	0.01
	10.11	140	0.07	0.18	0.17	0.07	0.00	0.00	0.00	0.00
	10.12	140	0.07	0.18	0.18	0.07	0.01	0.02	0.02	0.01

The bolded and gray highlighted values denote a risk (RQ≥1) to the aquatic environment where the surface water concentration (SWC) exceeds the concentration of concern (COC) for acute, algae or chronic environmental hazard. Underlined SWCs indicate when the predicted surface water release of HBCD for a sub-scenario exceeds the water solubility of HBCD (66 µg/L), resulting in acute, algae or chronic RQs greater than 165, 66, and 158.3, respectively.										
Exposure Scenario	Sub-Scenario	Days of Release	10th Percentile 7Q10				50th percentile: 7Q10			
			SWC (µg/L)	Acute RQ (COC: 0.4 µg/L)	Chronic RQ (COC: 0.417 µg/L)	Algae RQ (COC: 1 µg/L)	SWC (µg/L)	Acute RQ (COC: 0.4 µg/L)	Chronic RQ (COC: 0.417 µg/L)	Algae RQ (COC: 1 µg/L)
Section 2.4.1.13 – Use of Flux/Solder Pastes (12)	12.1	4	0.31	0.78	0.74	0.31	0.01	0.02	0.01	0.01
	12.2	4	0.32	0.80	0.77	0.32	0.03	0.08	0.08	0.03
	12.3	300	0.00	0.01	0.01	0.00	0.00	0.00	0.00	0.00
	12.4	300	0.00	0.01	0.01	0.00	0.00	0.00	0.00	0.00
	12.5	4	0.62	1.55	1.49	0.62	0.01	0.03	0.03	0.01
	12.6	4	0.64	1.60	1.53	0.64	0.06	0.16	0.15	0.06
	12.7	300	0.01	0.02	0.02	0.01	0.00	0.00	0.00	0.00
	12.8	300	0.01	0.02	0.02	0.01	0.00	0.00	0.00	0.00

J.1.1.2 PSC Predicted Surface Water and Sediment Concentrations

Table_Apx J-2. Calculated Risk Quotients based on Estimated HBCD Surface Water Concentrations (µg/L) Using PSC (0% Removal)

The bolded and gray highlighted values denote a risk (RQ≥1) to the aquatic environment where the surface water concentration (SWC) exceeds the concentration of concern (COC) for acute, algae or chronic environmental hazard. Underlined SWCs indicate when the predicted surface water release of HBCD for a sub-scenario exceeds the water solubility of HBCD (66 µg/L), resulting in acute, algae or chronic RQs greater than 165, 66, and 158.3, respectively.												
Exposure Scenario	Sub-Scenario	Days of Release	10th percentile					50th percentile				
			1-day SWC (µg/L)	RQs based on 1-d SWC		21-day SWC: µg/L	RQs based on 21-d SWC	1-day SWC (µg/L)	RQs based on 1-d SWC		21-day SWC: µg/L	RQs based on 21-d SWC
				Acute RQ (COC: 0.4 µg/L)	Algae RQ (COC: 1 µg/L)		Chronic RQ (COC: 0.417 µg/L)		Acute RQ (COC: 0.4 µg/L)	Algae RQ (COC: 1 µg/L)		Chronic RQ (COC: 0.417 µg/L)
Section 2.4.1.2 – Repackaging of Import Containers (1)	1.1	29	14.70	36.75	14.70	1.71	4.10	0.38	0.96	0.38	0.04	0.09
	1.2	300	1.72	4.30	1.72	1.46	3.50	0.04	0.09	0.04	0.03	0.07
	1.3	29	<u>73.70</u>	184.25	73.70	8.59	20.60	1.93	4.83	1.93	0.18	0.44
	1.4	300	8.69	21.73	8.69	7.35	17.63	0.19	0.47	0.19	0.15	0.36
	1.5	29	15.10	37.75	15.10	1.77	4.24	1.93	4.83	1.93	0.19	0.45
	1.6	300	1.78	4.45	1.78	1.51	3.62	0.19	0.48	0.19	0.16	0.37
	1.7	29	<u>75.60</u>	189.00	75.60	8.85	21.22	9.68	24.20	9.68	0.94	2.26
	1.8	300	8.96	22.40	8.96	7.59	18.20	0.96	2.40	0.96	0.78	1.87
Section 2.4.1.3 – Compounding of Polystyrene Resin to Produce XPS Masterbatch (2)	2.1	10	13.90	34.75	13.90	0.79	1.88	0.37	0.92	0.37	0.02	0.04
	2.2	60	2.36	5.90	2.36	0.54	1.30	0.06	0.15	0.06	0.02	0.04
	2.3	10	31.30	78.25	31.30	1.76	4.22	0.83	2.08	0.83	0.04	0.10
	2.4	60	5.43	13.58	5.43	1.25	3.00	0.14	0.35	0.14	0.03	0.06
	2.5	10	1.39	3.48	1.39	0.08	0.19	0.04	0.09	0.04	0.00	0.00
	2.6	60		0.00	0.00		0.00		0.00	0.00		0.00
	2.7	10	3.13	7.83	3.13	0.18	0.42	0.08	0.21	0.08	0.00	0.01
	2.8	60		0.00	0.00		0.00		0.00	0.00		0.00

The bolded and gray highlighted values denote a risk (RQ≥1) to the aquatic environment where the surface water concentration (SWC) exceeds the concentration of concern (COC) for acute, algae or chronic environmental hazard. Underlined SWCs indicate when the predicted surface water release of HBCD for a sub-scenario exceeds the water solubility of HBCD (66 µg/L), resulting in acute, algae or chronic RQs greater than 165, 66, and 158.3, respectively.												
Exposure Scenario	Sub-Scenario	Days of Release	10th percentile					50th percentile				
			1-day SWC (µg/L)	RQs based on 1-d SWC		21-day SWC: µg/L	RQs based on 21-d SWC	1-day SWC (µg/L)	RQs based on 1-d SWC		21-day SWC: µg/L	RQs based on 21-d SWC
				Acute RQ (COC: 0.4 µg/L)	Algae RQ (COC: 1 µg/L)		Chronic RQ (COC: 0.417 µg/L)		Acute RQ (COC: 0.4 µg/L)	Algae RQ (COC: 1 µg/L)		Chronic RQ (COC: 0.417 µg/L)
	2.9	10	1.43	3.58	1.43	0.08	0.19	0.19	0.46	0.19	0.01	0.02
	2.10	60		0.00	0.00		0.00		0.00	0.00		0.00
	2.11	10	3.21	8.03	3.21	0.18	0.44	0.42	1.04	0.42	0.02	0.05
	2.12	60		0.00	0.00		0.00		0.00	0.00		0.00
Section 2.4.1.4 – Processing of HBCD to produce XPS Foam using XPS Masterbatch (3)	3.1	1	44.90	112.25	44.90	2.31	5.54	1.20	3.00	1.20	0.06	0.14
	3.2	15	3.02	7.55	3.02	0.18	0.43	0.08	0.20	0.08	0.00	0.01
	3.3	1	<u>110.00</u>	275.00	110.00	5.65	13.55	2.93	7.33	2.93	0.14	0.34
	3.4	15	7.46	18.65	7.46	0.45	1.07	0.20	0.49	0.20	0.01	0.02
	3.5	1	4.49	11.23	4.49	0.23	0.55	0.12	0.30	0.12	0.01	0.01
	3.6	15	0.30	0.76	0.30	0.02	0.04	0.01	0.02	0.01	0.00	0.00
	3.7	1	11.00	27.50	11.00	0.57	1.35	0.29	0.73	0.29	0.01	0.03
	3.8	15	0.75	1.87	0.75	0.04	0.11	0.02	0.05	0.02	0.00	0.00
	3.9	1	4.60	11.50	4.60	0.24	0.57	0.60	1.50	0.60	0.03	0.07
	3.10	15	0.31	0.78	0.31	0.02	0.04	0.04	0.10	0.04	0.00	0.00
	3.11	1	11.30	28.25	11.30	0.58	1.39	1.47	3.68	1.47	0.07	0.17
	3.12	15	0.77	1.91	0.77	0.05	0.11	0.10	0.25	0.10	0.00	0.01
Section 2.2.5 – Processing of HBCD to produce XPS Foam using HBCD Powder (4)	4.1	1	42.80	107.00	42.80	2.19	5.25	1.14	2.85	1.14	0.05	0.13
	4.2	12	3.63	9.08	3.63	0.21	0.49	0.10	0.24	0.10	0.00	0.01
	4.3	1	4.28	10.70	4.28	0.22	0.53	0.11	0.29	0.11	0.01	0.01
	4.4	12	0.36	0.91	0.36	0.02	0.05	0.01	0.02	0.01	0.00	0.00

The bolded and gray highlighted values denote a risk (RQ≥1) to the aquatic environment where the surface water concentration (SWC) exceeds the concentration of concern (COC) for acute, algae or chronic environmental hazard. Underlined SWCs indicate when the predicted surface water release of HBCD for a sub-scenario exceeds the water solubility of HBCD (66 µg/L), resulting in acute, algae or chronic RQs greater than 165, 66, and 158.3, respectively.												
Exposure Scenario	Sub-Scenario	Days of Release	10th percentile					50th percentile				
			1-day SWC (µg/L)	RQs based on 1-d SWC		21-day SWC: µg/L	RQs based on 21-d SWC	1-day SWC (µg/L)	RQs based on 1-d SWC		21-day SWC: µg/L	RQs based on 21-d SWC
				Acute RQ (COC: 0.4 µg/L)	Algae RQ (COC: 1 µg/L)		Chronic RQ (COC: 0.417 µg/L)		Acute RQ (COC: 0.4 µg/L)	Algae RQ (COC: 1 µg/L)		Chronic RQ (COC: 0.417 µg/L)
	4.5	1	4.38	10.95	4.38	0.23	0.54	0.57	1.43	0.57	0.03	0.07
	4.6	12	0.37	0.93	0.37	0.02	0.05	0.05	0.12	0.05	0.00	0.01
Section 2.4.1.6 – Processing of HBCD to produce EPS Foam from Imported EPS Resin Beads (5)	5.1	16	<u>2900.00</u>	7250.00	2900.00	<u>172.00</u>	412.47	<u>76.60</u>	191.50	76.60	3.67	8.80
	5.2	16	<u>290.00</u>	725.00	290.00	17.20	41.25	7.66	19.15	7.66	0.37	0.88
	5.3	16	<u>297.00</u>	742.50	297.00	17.70	42.45	38.50	96.25	38.50	1.88	4.51
	5.4	140	<u>358.00</u>	895.00	358.00	<u>140.00</u>	335.73	8.78	21.95	8.78	2.94	7.05
	5.5	140	35.80	89.50	35.80	14.00	33.57	0.88	2.20	0.88	0.29	0.71
	5.6	140	36.80	92.00	36.80	14.40	34.53	4.44	11.10	4.44	1.51	3.62
	5.7	16	<u>3960.00</u>	9900.00	3960.00	<u>235.00</u>	563.55	<u>105.00</u>	262.50	105.00	5.01	12.01
	5.8	16	<u>396.00</u>	990.00	396.00	23.50	56.35	10.50	26.25	10.50	0.50	1.20
	5.9	16	<u>406.00</u>	1015.00	406.00	24.20	58.03	52.50	131.25	52.50	2.57	6.16
	5.10	140	<u>489.00</u>	1222.50	489.00	<u>191.00</u>	458.03	12.00	30.00	12.00	4.01	9.62
	5.11	140	48.90	122.25	48.90	19.10	45.80	1.20	3.00	1.20	0.40	0.96
5.12	140	50.30	125.75	50.30	19.70	47.24	6.06	15.15	6.06	2.06	4.94	
Section 2.4.1.7 – Processing of HBCD to produce SIPs and Automobile Replacement Parts from XPS/EPS Foam (6)	6.1	16	13.30	33.25	13.30	0.79	1.89	0.35	0.88	0.35	0.02	0.04
	6.2	16	1.33	3.33	1.33	0.08	0.19	0.04	0.09	0.04	0.00	0.00
	6.3	16	1.37	3.43	1.37	0.08	0.20	0.18	0.44	0.18	0.01	0.02
	6.4	300	0.87	2.17	0.87	0.77	1.84	0.02	0.05	0.02	0.02	0.04
	6.5	300		0.00	0.00		0.00		0.00	0.00		0.00
	6.6	300		0.00	0.00		0.00		0.00	0.00		0.00

The bolded and gray highlighted values denote a risk (RQ≥1) to the aquatic environment where the surface water concentration (SWC) exceeds the concentration of concern (COC) for acute, algae or chronic environmental hazard. Underlined SWCs indicate when the predicted surface water release of HBCD for a sub-scenario exceeds the water solubility of HBCD (66 µg/L), resulting in acute, algae or chronic RQs greater than 165, 66, and 158.3, respectively.												
Exposure Scenario	Sub-Scenario	Days of Release	10th percentile					50th percentile				
			1-day SWC (µg/L)	RQs based on 1-d SWC		21-day SWC: µg/L	RQs based on 21-d SWC	1-day SWC (µg/L)	RQs based on 1-d SWC		21-day SWC: µg/L	RQs based on 21-d SWC
				Acute RQ (COC: 0.4 µg/L)	Algae RQ (COC: 1 µg/L)		Chronic RQ (COC: 0.417 µg/L)		Acute RQ (COC: 0.4 µg/L)	Algae RQ (COC: 1 µg/L)		Chronic RQ (COC: 0.417 µg/L)
	6.7	16	59.50	148.75	59.50	3.53	8.47	1.57	3.93	1.57	0.08	0.18
	6.8	16	5.95	14.88	5.95	0.35	0.85	0.16	0.39	0.16	0.01	0.02
	6.9	16	6.10	15.25	6.10	0.36	0.87	0.79	1.97	0.79	0.04	0.09
	6.10	300	3.87	9.68	3.87	3.41	8.18	0.08	0.21	0.08	0.07	0.17
	6.11	300	0.39	0.97	0.39	0.34	0.82	0.01	0.02	0.01	0.01	0.02
	6.12	300	0.40	1.00	0.40	0.35	0.84	0.04	0.11	0.04	0.04	0.09
Section 2.4.1.9 – Installation of XPS/EPS Foam Insulation in Residential, Public, and Commercial Buildings, and Other Structures (8)	8.1	1	0.02	0.05	0.02	0.00	0.00	0.00	0.01	0.00	0.00	0.00
	8.2	1	0.00	0.00	0.00	0.00	0.00	0.00	0.00	0.00	0.00	0.00
	8.3	3	23.70	59.25	23.70	1.71	4.10	3.38	8.45	3.38	0.02	0.04
	8.4	3	2.37	5.93	2.37	0.17	0.41	0.34	0.85	0.34	0.00	0.00
Section 2.4.1.10 – Demolition of XPS/EPS Foam Insulation Products in Residential, Public and Commercial Buildings, and Other Structures (9)	9.1	1	0.02	0.05	0.02	0.00	0.00	0.00	0.01	0.00	0.00	0.00
	9.2	1	0.00	0.00	0.00	0.00	0.00	0.00	0.00	0.00	0.00	0.00
	9.3	3	23.70	59.25	23.70	1.71	4.10	3.38	8.45	3.38	0.02	0.04
	9.4	3	2.37	5.93	2.37	0.17	0.41	0.34	0.85	0.34	0.00	0.00
Section 2.4.1.11 – Recycling of EPS Foam and Reuse of XPS Foam (10)	10.1	1	61.60	154.00	61.60	3.16	7.58	1.64	4.10	1.64	0.08	0.19
	10.2	1	6.16	15.40	6.16	0.32	0.76	0.16	0.41	0.16	0.01	0.02
	10.3	1	6.31	15.78	6.31	0.33	0.78	0.82	2.06	0.82	0.04	0.09
	10.4	140	0.48	1.20	0.48	0.19	0.45	0.01	0.03	0.01	0.00	0.01
	10.5	140	0.00	0.00	0.00	0.00	0.00	0.00	0.00	0.00	0.00	0.00
	10.6	140	0.00	0.00	0.00	0.00	0.00	0.00	0.00	0.00	0.00	0.00

The bolded and gray highlighted values denote a risk (RQ≥1) to the aquatic environment where the surface water concentration (SWC) exceeds the concentration of concern (COC) for acute, algae or chronic environmental hazard. Underlined SWCs indicate when the predicted surface water release of HBCD for a sub-scenario exceeds the water solubility of HBCD (66 µg/L), resulting in acute, algae or chronic RQs greater than 165, 66, and 158.3, respectively.												
Exposure Scenario	Sub-Scenario	Days of Release	10th percentile					50th percentile				
			1-day SWC (µg/L)	RQs based on 1-d SWC		21-day SWC: µg/L	RQs based on 21-d SWC	1-day SWC (µg/L)	RQs based on 1-d SWC		21-day SWC: µg/L	RQs based on 21-d SWC
				Acute RQ (COC: 0.4 µg/L)	Algae RQ (COC: 1 µg/L)				Chronic RQ (COC: 0.417 µg/L)	Acute RQ (COC: 0.4 µg/L)		
	10.7	1	<u>73.30</u>	183.25	73.30	3.76	9.02	1.95	4.88	1.95	0.09	0.22
	10.8	1	7.33	18.33	7.33	0.38	0.90	0.20	0.49	0.20	0.01	0.02
	10.9	1	7.51	18.78	7.51	0.39	0.93	0.98	2.45	0.98	0.05	0.11
	10.10	140	0.57	1.43	0.57	0.22	0.53	0.01	0.04	0.01	0.00	0.01
	10.11	140	0.00	0.00	0.00	0.00	0.00	0.00	0.00	0.00	0.00	0.00
	10.12	140	0.00	0.00	0.00	0.00	0.00	0.00	0.00	0.00	0.00	0.00
Section 2.4.1.13 – Use of Flux/Solder Pastes (12)	12.1	4	0.23	0.58	0.23	0.01	0.03	0.01	0.02	0.01	0.00	0.00
	12.2	4	0.24	0.59	0.24	0.01	0.03	0.03	0.08	0.03	0.00	0.00
	12.3	300	0.00	0.00	0.00	0.00	0.00	0.00	0.00	0.00	0.00	0.00
	12.4	300	0.00	0.00	0.00	0.00	0.00	0.00	0.00	0.00	0.00	0.00
	12.5	4	0.46	1.16	0.46	0.02	0.06	0.01	0.03	0.01	0.00	0.00
	12.6	4	0.47	1.19	0.47	0.03	0.06	0.06	0.15	0.06	0.00	0.01
	12.7	300	0.00	0.00	0.00	0.00	0.00	0.00	0.00	0.00	0.00	0.00
12.8	300	0.00	0.00	0.00	0.00	0.00	0.00	0.00	0.00	0.00	0.00	

Table_Apx J-3. Calculated Risk Quotients based on Estimated HBCD Sediment Concentrations (µg/kg) Using PSC (0% Removal)

The bolded and gray highlighted values denote a risk (RQ≥1) to the aquatic environment where the sediment HBCD concentration exceeds the concentration of concern (COC) for chronic environmental hazard. The shaded values in yellow denote predicted sediment concentrations by PSC. Blank spaces denote scenarios where HBCD sediment concentrations are <100 µg/kg for segments of a water body within 100 meters of the facility; these scenarios were not run because the surface water concentrations that less than the chronic COC of 1,570 µg/kg.

Exposure Scenario	Sub-Scenario	Days of Release	10th percentile				50th percentile			
			11-d half-life		128-d half-life		11-d half-life		128-d half-life	
			Sediment: µg/kg	RQ (COC: 1,570 µg/kg)	Sediment: µg/kg	RQ (COC: 1,570 µg/kg)	Sediment: µg/kg	RQ (COC: 1,570 µg/kg)	Sediment: µg/kg	RQ (COC: 1,570 µg/kg)
Section 2.4.1.2 – Repackaging of Import Containers (1)	1.1	29	1400	0.89	3620	2.31	34.4	0.02	77	0.05
	1.2	300	1380	0.88	3600	2.29	33.8	0.02	76.7	0.05
	1.3	29	7040	4.48	18200	11.59	172	0.11	386	0.25
	1.4	300	6980	4.45	18200	11.59	170	0.11	385	0.25
	1.5	29	1440	0.92	3730	2.38	174	0.11	395	0.25
	1.6	300	1420	0.90	3720	2.37	171	0.11	393	0.25
	1.7	29	7230	4.61	18700	11.91	872	0.56	1980	1.26
	1.8	300	7170	4.57	18700	11.91	862	0.55	1980	1.26
Section 2.4.1.3 – Compounding of Polystyrene Resin to Produce XPS Masterbatch (2)	2.1	10	537	0.34	1300	0.83	13.3	0.01	27.9	0.02
	2.2	60	471	0.30	1220	0.78	11.5	0.01	26	0.02
	2.3	10	1210	0.77	2920	1.86	29.8	0.02	62.8	0.04
	2.4	60	1080	0.69	2810	1.79	26.5	0.02	59.7	0.04
	2.5	10	53.7	0.03	130	0.08	1.33	0.00	2.79	0.00
	2.6	60								
	2.7	10	121	0.08	292	0.19	2.98	0.00	6.28	0.00
	2.8	60								
	2.9	10	55.1	0.04	134	0.09	6.72	0.00	14.3	0.01
	2.1	60								
	2.11	10	124	0.08	301	0.19	15.1	0.01	32.2	0.02

The bolded and gray highlighted values denote a risk (RQ≥1) to the aquatic environment where the sediment HBCD concentration exceeds the concentration of concern (COC) for chronic environmental hazard. The shaded values in yellow denote predicted sediment concentrations by PSC. Blank spaces denote scenarios where HBCD sediment concentrations are <100 µg/kg for segments of a water body within 100 meters of the facility; these scenarios were not run because the surface water concentrations that less than the chronic COC of 1,570 µg/kg.										
Exposure Scenario	Sub-Scenario	Days of Release	10th percentile				50th percentile			
			11-d half-life		128-d half-life		11-d half-life		128-d half-life	
			Sediment: µg/kg	RQ (COC: 1,570 µg/kg)	Sediment: µg/kg	RQ (COC: 1,570 µg/kg)	Sediment: µg/kg	RQ (COC: 1,570 µg/kg)	Sediment: µg/kg	RQ (COC: 1,570 µg/kg)
	2.12	60								
Section 2.4.1.4 – Processing of HBCD to produce XPS Foam using XPS Masterbatch (3)	3.1	1	1430	0.91	1910	1.22	36.4	0.02	48.3	0.03
	3.2	15	163	0.10	414	0.26	4.01	0.00	8.86	0.01
	3.3	1	3490	2.22	4670	2.97	89.1	0.06	118	0.08
	3.4	15	403	0.26	1020	0.65	9.9	0.01	21.9	0.01
	3.5	1	143	0.09	191	0.12	3.64	0.00	4.83	0.00
	3.6	15	16.3	0.01	41.4	0.03	0.4	0.00	0.89	0.00
	3.7	1	349	0.22	467	0.30	8.91	0.01	11.8	0.01
	3.8	15	40.3	0.03	102	0.06	0.99	0.00	2.19	0.00
	3.9	1	146	0.09	196	0.12	18.3	0.01	24.4	0.02
	3.10	15	16.8	0.01	42.7	0.03	2.03	0.00	4.54	0.00
	3.11	1	358	0.23	479	0.31	44.9	0.03	59.7	0.04
	3.12	15	41.4	0.03	105	0.07	5.01	0.00	11.2	0.01
Section 2.2.5 – Processing of HBCD to produce XPS Foam using HBCD Powder (4)	4.1	1	1360	0.87	1820	1.16	34.7	0.02	46	0.03
	4.2	12	152	0.10	385	0.25	3.73	0.00	8.22	0.01
	4.3	1	136	0.09	182	0.12	3.47	0.00	4.6	0.00
	4.4	12	15.2	0.01	38.5	0.02	0.37	0.00	0.82	0.00
	4.5	1	139	0.09	186	0.12	17.5	0.01	23.2	0.01
	4.6	12	15.6	0.01	39.7	0.03	1.89	0.00	4.22	0.00
	5.1	16	165000	105.10	417000	265.61	4050	2.58	8910	5.68
	5.2	16	16500	10.51	41700	26.56	405	0.26	891	0.57

The bolded and gray highlighted values denote a risk ($RQ \geq 1$) to the aquatic environment where the sediment HBCD concentration exceeds the concentration of concern (COC) for chronic environmental hazard. The shaded values in yellow denote predicted sediment concentrations by PSC. Blank spaces denote scenarios where HBCD sediment concentrations are $< 100 \mu\text{g/kg}$ for segments of a water body within 100 meters of the facility; these scenarios were not run because the surface water concentrations that less than the chronic COC of $1,570 \mu\text{g/kg}$.										
Exposure Scenario	Sub-Scenario	Days of Release	10th percentile				50th percentile			
			11-d half-life		128-d half-life		11-d half-life		128-d half-life	
			Sediment: $\mu\text{g/kg}$	RQ (COC: $1,570 \mu\text{g/kg}$)	Sediment: $\mu\text{g/kg}$	RQ (COC: $1,570 \mu\text{g/kg}$)	Sediment: $\mu\text{g/kg}$	RQ (COC: $1,570 \mu\text{g/kg}$)	Sediment: $\mu\text{g/kg}$	RQ (COC: $1,570 \mu\text{g/kg}$)
Section 2.4.1.6 – Processing of HBCD to produce EPS Foam from Imported EPS Resin Beads (5)	5.3	16	16900	10.76	42900	27.32	2050	1.31	4560	2.90
	5.4	140	137000	87.26	356000	226.75	3340	2.13	7560	4.82
	5.5	140	13700	8.73	35600	22.68	334	0.21	756	0.48
	5.6	140	14100	8.98	36800	23.44	1690	1.08	3880	2.47
	5.7	16	225000	143.31	568000	361.78	5530	3.52	12200	7.77
	5.8	16	22500	14.33	56800	36.18	553	0.35	1220	0.78
	5.9	16	23100	14.71	58600	37.32	2800	1.78	6230	3.97
	5.1	140	187000	119.11	487000	310.19	4560	2.90	10300	6.56
	5.11	140	18700	11.91	48700	31.02	456	0.29	1030	0.66
	5.12	140	19200	12.23	50200	31.97	2330	1.48	5300	3.38
Section 2.4.1.7 – Processing of HBCD to produce SIPs and Automobile Replacement Parts from XPS/EPS Foam (6)	6.1	16	758	0.48	1910	1.22	18.6	0.01	40.9	0.03
	6.2	16	75.8	0.05	191	0.12	1.86	0.00	4.09	0.00
	6.3	16	77.8	0.05	197	0.13	9.42	0.01	21	0.01
	6.4	300	735	0.47	1910	1.22	17.9	0.01	40.6	0.03
	6.5	300								
	6.6	300								
	6.7	16	3380	2.15	8540	5.44	83	0.05	183	0.12
	6.8	16	338	0.22	854	0.54	8.3	0.01	18.3	0.01
	6.9	16	347	0.22	880	0.56	42	0.03	93.6	0.06
	6.10	300	3270	2.08	8510	5.42	79.8	0.05	181	0.12
	6.11	300	327	0.21	851	0.54	7.98	0.01	18.1	0.01

The bolded and gray highlighted values denote a risk ($RQ \geq 1$) to the aquatic environment where the sediment HBCD concentration exceeds the concentration of concern (COC) for chronic environmental hazard. The shaded values in yellow denote predicted sediment concentrations by PSC. Blank spaces denote scenarios where HBCD sediment concentrations are $< 100 \mu\text{g/kg}$ for segments of a water body within 100 meters of the facility; these scenarios were not run because the surface water concentrations that less than the chronic COC of $1,570 \mu\text{g/kg}$.

Exposure Scenario	Sub-Scenario	Days of Release	10th percentile				50th percentile			
			11-d half-life		128-d half-life		11-d half-life		128-d half-life	
			Sediment: $\mu\text{g/kg}$	RQ (COC: $1,570 \mu\text{g/kg}$)	Sediment: $\mu\text{g/kg}$	RQ (COC: $1,570 \mu\text{g/kg}$)	Sediment: $\mu\text{g/kg}$	RQ (COC: $1,570 \mu\text{g/kg}$)	Sediment: $\mu\text{g/kg}$	RQ (COC: $1,570 \mu\text{g/kg}$)
	6.12	300	336	0.21	878	0.56	40.4	0.03	92.7	0.06
Section 2.4.1.9 – Installation of XPS/EPS Foam Insulation in Residential, Public, and Commercial Buildings, and Other Structures (8)	8.1	1	0.76	0.00	1.05	0.00	0.09	0.00	0.12	0.00
	8.2	1								
	8.3	3	898	0.57	2010	1.28	105	0.07	161.0	0.10
	8.4	3	89.8	0.06	201	0.13	10.5	0.01	16.1	0.01
Section 2.4.1.10 – Demolition of XPS/EPS Foam Insulation Products in Residential, Public and Commercial Buildings, and Other Structures (9)	9.1	1	0.76	0.00	1.05	0.00	0.09	0.00	0.12	0.00
	9.2	1								
	9.3	3	159	0.10	10.2	0.01	22.8	0.01	1.1	0.00
	9.4	3	15.9	0.01	1.02	0.00	2.28	0.00	0.1	0.00
Section 2.4.1.11 – Recycling of EPS Foam and Reuse of XPS Foam (10)	10.1	1	1960	1.25	2620	1.67	49.9	0.03	66.3	0.04
	10.2	1	196	0.12	262	0.17	4.99	0.00	6.63	0.00
	10.3	1	201	0.13	268	0.17	25.2	0.02	33.4	0.02
	10.4	140	184	0.12	478	0.30	4.48	0.00	10.1	0.01
	10.5	140								
	10.6	140								
	10.7	1	2330	1.48	3110	1.98	59.5	0.04	95.6	0.06
	10.8	1	233	0.15	311	0.20	5.95	0.00	9.56	0.01
	10.9	1	239	0.15	320	0.20	30	0.02	39.8	0.03
	10.10	140	218	0.14	568	0.36	5.32	0.00	12	0.01
	10.11	140								
	10.12	140								

The bolded and gray highlighted values denote a risk (RQ≥1) to the aquatic environment where the sediment HBCD concentration exceeds the concentration of concern (COC) for chronic environmental hazard. The shaded values in yellow denote predicted sediment concentrations by PSC. Blank spaces denote scenarios where HBCD sediment concentrations are <100 µg/kg for segments of a water body within 100 meters of the facility; these scenarios were not run because the surface water concentrations that less than the chronic COC of 1,570 µg/kg.										
Exposure Scenario	Sub-Scenario	Days of Release	10th percentile				50th percentile			
			11-d half-life		128-d half-life		11-d half-life		128-d half-life	
			Sediment: µg/kg	RQ (COC: 1,570 µg/kg)	Sediment: µg/kg	RQ (COC: 1,570 µg/kg)	Sediment: µg/kg	RQ (COC: 1,570 µg/kg)	Sediment: µg/kg	RQ (COC: 1,570 µg/kg)
Section 2.4.1.13 – Use of Flux/Solder Pastes (12)	12.1	4	7.37	0.00	12.5	0.01	0.19	0.00	0.29	0.00
	12.2	4	7.56	0.00	12.9	0.01	0.95	0.00	1.47	0.00
	12.3	300								
	12.4	300								
	12.5	4	14.7	0.01	25	0.02	0.38	0.00	0.58	0.00
	12.6	4	15.1	0.01	25.7	0.02	1.89	0.00	2.94	0.00
	12.7	300								
	12.8	300								

J.1.2 Targeted Sensitivity Analysis

J.1.2.1 Exposure Scenario 1: Repackaging of Import Containers

Table_Apx J-4. Calculated Risk Quotients based on Estimated HBCD Surface Water Concentrations (µg/L) Using PSC (Targeted Sensitivity Analysis Parameter: Production Volume)

The bolded and gray highlighted values denote a risk (RQ≥1) to the aquatic environment where the surface water concentration (SWC) exceeds the concentration of concern (COC). Underlined SWCs indicate when the predicted surface water release of HBCD for a sub-scenario exceeds the water solubility of HBCD (66 µg/L), resulting in acute, algae or chronic RQs greater than 165, 66, and 158.3, respectively. For this exposure scenario, HBCD is released following treatment via an onsite WWT or POTW and there are not any sub-scenarios where direct release of HBCD into surface water is expected.

Exposure Scenario	Sub-Scenario	Production Volume (lbs/yr)	10th percentile					50th percentile				
			1-day SWC (µg/L)	RQs based on 1-d SWC		21-day SWC: µg/L	RQs based on 21-d SWC	1-day SWC (µg/L)	RQs based on 1-d SWC		21-day SWC: µg/L	RQs based on 21-d SWC
				Acute RQ (COC: 0.4 µg/L)	Algae RQ (COC: 1 µg/L)		Chronic RQ (COC: 0.417 µg/L)		Acute RQ (COC: 0.4 µg/L)	Algae RQ (COC: 1 µg/L)		Chronic RQ (COC: 0.417 µg/L)
Section 2.4.1.2 – Repackaging of Import Containers (1)	1.1	100,000	14.70	36.75	14.70	1.71	4.10	0.38	0.96	0.38	0.04	0.09
	1.2		1.72	4.30	1.72	1.46	3.50	0.04	0.09	0.04	0.03	0.07
	1.3		<u>73.70</u>	184.25	73.70	8.59	20.60	1.93	4.83	1.93	0.18	0.44
	1.4		8.69	21.73	8.69	7.35	17.63	0.19	0.47	0.19	0.15	0.36
	1.5		15.10	37.75	15.10	1.77	4.24	1.93	4.83	1.93	0.19	0.45
	1.6		1.78	4.45	1.78	1.51	3.62	0.19	0.48	0.19	0.16	0.37
	1.7		<u>75.60</u>	189.00	75.60	8.85	21.22	9.68	24.20	9.68	0.94	2.26
	1.8		8.96	22.40	8.96	7.59	18.20	0.96	2.40	0.96	0.78	1.87
Section 2.4.1.2 – Repackaging of Import Containers (1)	1.1	50,000	14.10	35.25	14.10	0.83	1.99	0.37	0.93	0.37	0.02	0.04
	1.2		1.57	3.93	1.57	0.92	2.20	0.04	0.09	0.04	0.02	0.05
	1.3		<u>70.50</u>	176.25	70.50	4.15	9.95	1.86	4.65	1.86	0.09	0.21
	1.4		7.94	19.85	7.94	4.62	11.08	0.19	0.47	0.19	0.10	0.24
	1.5		14.40	36.00	14.40	0.85	2.05	1.87	4.68	1.87	0.09	0.22
	1.6		1.62	4.05	1.62	0.95	2.27	0.19	0.47	0.19	0.10	0.24
	1.7		<u>72.20</u>	180.50	72.20	4.27	10.24	9.35	23.38	9.35	0.46	1.10

The bolded and gray highlighted values denote a risk ($RQ \geq 1$) to the aquatic environment where the surface water concentration (SWC) exceeds the concentration of concern (COC). Underlined SWCs indicate when the predicted surface water release of HBCD for a sub-scenario exceeds the water solubility of HBCD ($66 \mu\text{g/L}$), resulting in acute, algae or chronic RQs greater than 165, 66, and 158.3, respectively. For this exposure scenario, HBCD is released following treatment via an onsite WWT or POTW and there are not any sub-scenarios where direct release of HBCD into surface water is expected.

Exposure Scenario	Sub-Scenario	Production Volume (lbs/yr)	10th percentile					50th percentile				
			1-day SWC ($\mu\text{g/L}$)	RQs based on 1-d SWC		21-day SWC: $\mu\text{g/L}$	RQs based on 21-d SWC	1-day SWC ($\mu\text{g/L}$)	RQs based on 1-d SWC		21-day SWC: $\mu\text{g/L}$	RQs based on 21-d SWC
				Acute RQ (COC: $0.4 \mu\text{g/L}$)	Algae RQ (COC: $1 \mu\text{g/L}$)		Chronic RQ (COC: $0.417 \mu\text{g/L}$)		Acute RQ (COC: $0.4 \mu\text{g/L}$)	Algae RQ (COC: $1 \mu\text{g/L}$)		Chronic RQ (COC: $0.417 \mu\text{g/L}$)
	1.8		8.16	20.40	8.16	4.77	11.44	0.95	2.37	0.95	0.50	1.21
Section 2.4.1.2 – Repackaging of Import Containers (1)	1.1	25,000	15.00	37.50	15.00	0.81	1.94	0.40	1.00	0.40	0.02	0.05
	1.2		1.46	3.65	1.46	0.41	0.97	0.04	0.09	0.04	0.01	0.02
	1.3		<u>75.00</u>	187.50	75.00	4.06	9.74	1.99	4.98	1.99	0.10	0.23
	1.4		7.35	18.38	7.35	2.05	4.92	0.19	0.47	0.19	0.04	0.11
	1.5		15.40	38.50	15.40	0.83	2.00	2.00	5.00	2.00	0.10	0.23
	1.6		1.50	3.75	1.50	0.42	1.00	0.19	0.47	0.19	0.05	0.11
	1.7		<u>76.90</u>	192.25	76.90	4.17	10.00	10.00	25.00	10.00	0.48	1.16
	1.8		7.54	18.85	7.54	2.11	5.06	0.94	2.35	0.94	0.23	0.55

Table_Apx J-5. Calculated Risk Quotients based on Estimated HBCD Sediment Concentrations (µg/kg) Using PSC (Targeted Sensitivity Analysis Parameter: Production Volume)

The bolded and gray highlighted values denote a risk (RQ≥1) to the aquatic environment where the sediment HBCD concentration exceeds the concentration of concern (COC). Sub-scenarios were removed if there were no RQs calculated based on either 10th or 50th percentile sediment concentration predictions that are ≥1. For this exposure scenario, HBCD is released following treatment via an onsite WWT or POTW and there are not any sub-scenarios where direct release of HBCD into surface water is expected.

Condition of Use	Sub-Scenario	Production Volume (lbs/yr)	11-d half-life: 10th percentile		128-d half-life: 10th percentile		11-d half-life: 50th percentile		128-d half-life: 50th percentile	
			Sediment: µg/kg	RQ (COC: 1,570 µg/kg)	Sediment: µg/kg	RQ (COC: 1,570 µg/kg)	Sediment: µg/kg	RQ (COC: 1,570 µg/kg)	Sediment: µg/kg	RQ (COC: 1,570 µg/kg)
Section 2.4.1.2 – Repackaging of Import Containers (1)	1.1	100,000	1400	0.89	3620	2.31	34.4	0.02	77	0.05
	1.2		1380	0.88	3600	2.29	33.8	0.02	76.7	0.05
	1.3		7040	4.48	18200	11.59	172	0.11	386	0.25
	1.4		6980	4.45	18200	11.59	170	0.11	385	0.25
	1.5		1440	0.92	3730	2.38	174	0.11	395	0.25
	1.6		1420	0.9	3720	2.37	171	0.11	393	0.25
	1.7		7230	4.61	18700	11.91	872	0.56	1980	1.26
	1.8		7170	4.57	18700	11.91	862	0.55	1980	1.26
Section 2.4.1.2 – Repackaging of Import Containers (1)	1.1	50,000	760	0.48	1930	1.23	18.7	0.01	41.3	0.03
	1.2		865	0.55	2250	1.43	21.1	0.01	47.8	0.03
	1.3		3810	2.43	9660	6.15	93.5	0.06	207	0.13
	1.4		4360	2.78	11400	7.26	106	0.07	241	0.15
	1.5		781	0.5	1990	1.27	94.5	0.06	212	0.14
	1.6		888	0.57	2320	1.48	107	0.07	245	0.16
	1.7		3910	2.49	9960	6.34	473	0.3	1060	0.68
	1.8		4480	2.85	11700	7.45	538	0.34	1240	0.79
Section 2.4.1.2 – Repackaging of Import Containers (1)	1.1	25,000	512	0.33	1120	0.71	12.8	0.01	24.7	0.02
	1.2		347	0.22	902	0.57	8.47	0.01	19.2	0.01
	1.3		2560	1.63	5580	3.55	63.9	0.04	123	0.08
	1.4		1750	1.11	4550	2.9	42.7	0.03	96.5	0.06
	1.5		525	0.33	1150	0.73	64.5	0.04	126	0.08

The bolded and gray highlighted values denote a risk ($RQ \geq 1$) to the aquatic environment where the sediment HBCD concentration exceeds the concentration of concern (COC). Sub-scenarios were removed if there were no RQs calculated based on either 10th or 50th percentile sediment concentration predictions that are ≥ 1 . For this exposure scenario, HBCD is released following treatment via an onsite WWT or POTW and there are not any sub-scenarios where direct release of HBCD into surface water is expected.

Condition of Use	Sub-Scenario	Production Volume (lbs/yr)	11-d half-life: 10th percentile		128-d half-life: 10th percentile		11-d half-life: 50th percentile		128-d half-life: 50th percentile	
			Sediment: $\mu\text{g}/\text{kg}$	RQ (COC: 1,570 $\mu\text{g}/\text{kg}$)	Sediment: $\mu\text{g}/\text{kg}$	RQ (COC: 1,570 $\mu\text{g}/\text{kg}$)	Sediment: $\mu\text{g}/\text{kg}$	RQ (COC: 1,570 $\mu\text{g}/\text{kg}$)	Sediment: $\mu\text{g}/\text{kg}$	RQ (COC: 1,570 $\mu\text{g}/\text{kg}$)
	1.6		356	0.23	930	0.59	42.9	0.03	98.3	0.06
	1.7		2630	1.68	5740	3.66	323	0.21	630	0.4
	1.8		1800	1.15	4690	2.99	216	0.14	495	0

J.1.2.2 Exposure Scenario 3: Processing of HBCD to produce XPS Foam using XPS Masterbatch

Table_Apx J-6. Calculated Risk Quotients based on Estimated HBCD Surface Water Concentrations (µg/L) Using PSC (Targeted Sensitivity Analysis Parameters: Production Volume)

The bolded and gray highlighted values denote a risk (RQ≥1) to the aquatic environment where the surface water concentration (SWC) exceeds the concentration of concern (COC). Underlined SWCs indicate when the predicted surface water release of HBCD for a sub-scenario exceeds the water solubility of HBCD (66 µg/L), resulting in acute, algae or chronic RQs greater than 165, 66, and 158.3, respectively. N/A indicates sub-scenarios where HBCD is released following treatment via an onsite WWT or POTW (not direct release). The sub-scenarios that are shaded green indicate that these HBCD releases are due to direct release.

Exposure Scenario	Sub-Scenario	Production Volume (lbs/yr)	% WWTP Removal for Direct Releases ^a	10th percentile					50th percentile				
				1-day SWC (µg/L)	RQs based on 1-d SWC		21-day SWC: µg/L	RQs based on 21-d SWC	1-day SWC (µg/L)	RQs based on 1-d SWC		21-day SWC: µg/L	RQs based on 21-d SWC
					Acute RQ (COC: 0.4 µg/L)	Algae RQ (COC: 1 µg/L)		Chronic RQ (COC: 0.417 µg/L)		Acute RQ (COC: 0.4 µg/L)	Algae RQ (COC: 1 µg/L)		Chronic RQ (COC: 0.417 µg/L)
Section 2.4.1.4 – Processing of HBCD to produce XPS Foam using XPS Masterbatch (3)	3.1	100,000	0	44.90	112.25	44.90	2.31	5.54	1.20	3.00	1.20	0.06	0.14
	3.2		0	3.02	7.55	3.02	0.18	0.43	0.08	0.20	0.08	0.00	0.01
	3.3		0	<u>110.00</u>	275.00	110.00	5.65	13.55	2.93	7.33	2.93	0.14	0.34
	3.4		0	7.46	18.65	7.46	0.45	1.07	0.20	0.49	0.20	0.01	0.02
	3.5		N/A	4.49	11.23	4.49	0.23	0.55	0.12	0.30	0.12	0.01	0.01
	3.6		N/A	0.30	0.76	0.30	0.02	0.04	0.01	0.02	0.01	0.00	0.00
	3.7		N/A	11.00	27.50	11.00	0.57	1.35	0.29	0.73	0.29	0.01	0.03
	3.8		N/A	0.75	1.87	0.75	0.04	0.11	0.02	0.05	0.02	0.00	0.00
	3.9		N/A	4.60	11.50	4.60	0.24	0.57	0.60	1.50	0.60	0.03	0.07
	3.10		N/A	0.31	0.78	0.31	0.02	0.04	0.04	0.10	0.04	0.00	0.00
	3.11		N/A	11.30	28.25	11.30	0.58	1.39	1.47	3.68	1.47	0.07	0.17
	3.12		N/A	0.77	1.91	0.77	0.05	0.11	0.10	0.25	0.10	0.00	0.01
Section 2.4.1.4 – Processing of HBCD to produce	3.1	50,000	0	22.40	56.00	22.40	1.15	2.76	0.60	1.50	0.60	0.03	0.07
	3.2		0	1.51	3.78	1.51	0.09	0.21	0.04	0.10	0.04	0.00	0.00
	3.3		0	55.40	138.50	55.40	2.84	6.81	1.48	3.70	1.48	0.07	0.17
	3.4		0	3.73	9.33	3.73	0.22	0.53	0.10	0.25	0.10	0.00	0.01

The bolded and gray highlighted values denote a risk (RQ≥1) to the aquatic environment where the surface water concentration (SWC) exceeds the concentration of concern (COC). Underlined SWCs indicate when the predicted surface water release of HBCD for a sub-scenario exceeds the water solubility of HBCD (66 µg/L), resulting in acute, algae or chronic RQs greater than 165, 66, and 158.3, respectively. N/A indicates sub-scenarios where HBCD is released following treatment via an onsite WWT or POTW (not direct release). The sub-scenarios that are shaded green indicate that these HBCD releases are due to direct release.

Exposure Scenario	Sub-Scenario	Production Volume (lbs/yr)	% WWTP Removal for Direct Releases ^a	10th percentile					50th percentile				
				1-day SWC (µg/L)	RQs based on 1-d SWC		21-day SWC: µg/L	RQs based on 21-d SWC	1-day SWC (µg/L)	RQs based on 1-d SWC		21-day SWC: µg/L	RQs based on 21-d SWC
					Acute RQ (COC: 0.4 µg/L)	Algae RQ (COC: 1 µg/L)		Chronic RQ (COC: 0.417 µg/L)		Acute RQ (COC: 0.4 µg/L)	Algae RQ (COC: 1 µg/L)		Chronic RQ (COC: 0.417 µg/L)
XPS Foam using XPS Masterbatch (3)	3.5	25,000	N/A	2.24	5.60	2.24	0.12	0.28	0.06	0.15	0.06	0.00	0.01
	3.6		N/A	0.15	0.38	0.15	0.01	0.02	0.00	0.01	0.00	0.00	0.00
	3.7		N/A	5.54	13.85	5.54	0.28	0.68	0.15	0.37	0.15	0.01	0.02
	3.8		N/A	0.37	0.93	0.37	0.02	0.05	0.01	0.02	0.01	0.00	0.00
	3.9		N/A	2.30	5.75	2.30	0.12	0.28	0.30	0.75	0.30	0.01	0.03
	3.10		N/A	0.16	0.39	0.16	0.01	0.02	0.02	0.05	0.02	0.00	0.00
	3.11		N/A	5.68	14.20	5.68	0.29	0.70	0.74	1.85	0.74	0.04	0.09
	3.12		N/A	0.38	0.96	0.38	0.02	0.05	0.05	0.12	0.05	0.00	0.01
Section 2.4.1.4 – Processing of HBCD to produce XPS Foam using XPS Masterbatch (3)	3.1	25,000	0	11.20	28.00	11.20	0.57	1.38	0.30	0.75	0.30	0.01	0.03
	3.2		0	0.76	1.89	0.76	0.04	0.11	0.02	0.05	0.02	0.00	0.00
	3.3		0	27.70	69.25	27.70	1.42	3.41	0.74	1.85	0.74	0.04	0.08
	3.4		0	1.86	4.65	1.86	0.11	0.26	0.05	0.12	0.05	0.00	0.01
	3.5		N/A	1.12	2.80	1.12	0.06	0.14	0.03	0.07	0.03	0.00	0.00
	3.6		N/A	0.08	0.19	0.08	#REF!	#REF!	0.00	0.00	0.00	0.00	0.00
	3.7		N/A	2.77	6.93	2.77	0.00	0.01	0.07	0.18	0.07	0.00	0.01
	3.8		N/A	0.19	0.47	0.19	#REF!	#REF!	0.00	0.01	0.00	0.00	0.00
	3.9		N/A	1.14	2.85	1.14	0.06	0.14	0.15	0.37	0.15	0.01	0.02
	3.10		N/A	0.08	0.19	0.08	0.00	0.01	0.01	0.03	0.01	0.00	0.00
3.11	N/A	2.84	7.10	2.84	0.15	0.35	0.37	0.93	0.37	0.02	0.04		

The bolded and gray highlighted values denote a risk ($RQ \geq 1$) to the aquatic environment where the surface water concentration (SWC) exceeds the concentration of concern (COC). Underlined SWCs indicate when the predicted surface water release of HBCD for a sub-scenario exceeds the water solubility of HBCD ($66 \mu\text{g/L}$), resulting in acute, algae or chronic RQs greater than 165, 66, and 158.3, respectively. N/A indicates sub-scenarios where HBCD is released following treatment via an onsite WWT or POTW (not direct release). The sub-scenarios that are shaded green indicate that these HBCD releases are due to direct release.

Exposure Scenario	Sub-Scenario	Production Volume (lbs/yr)	% WWTP Removal for Direct Releases ^a	10th percentile					50th percentile				
				1-day SWC ($\mu\text{g/L}$)	RQs based on 1-d SWC		21-day SWC: $\mu\text{g/L}$	RQs based on 21-d SWC	1-day SWC ($\mu\text{g/L}$)	RQs based on 1-d SWC		21-day SWC: $\mu\text{g/L}$	RQs based on 21-d SWC
					Acute RQ (COC: $0.4 \mu\text{g/L}$)	Algae RQ (COC: $1 \mu\text{g/L}$)		Chronic RQ (COC: $0.417 \mu\text{g/L}$)		Acute RQ (COC: $0.4 \mu\text{g/L}$)	Algae RQ (COC: $1 \mu\text{g/L}$)		Chronic RQ (COC: $0.417 \mu\text{g/L}$)
	3.12		N/A	0.19	0.48	0.19	0.01	0.03	0.02	0.06	0.02	0.00	0.00

Table_Apx J-7. Calculated Risk Quotients based on Estimated HBCD Sediment Concentrations ($\mu\text{g/kg}$) Using PSC (Targeted Sensitivity Analysis Parameters: Production Volume)

The bolded and gray highlighted values denote a risk ($RQ \geq 1$) to the aquatic environment where the sediment HBCD concentration exceeds the concentration of concern (COC). N/A indicates sub-scenarios where HBCD is released following treatment via an onsite WWT or POTW (not direct release). The sub-scenarios that are shaded green indicate that these HBCD releases are due to direct release. Sub-scenarios were removed if there were no RQs calculated based on either 10th or 50th percentile sediment concentration predictions that are ≥ 1 .

Condition of Use	Sub-Scenario	Production Volume (lbs/yr)	% WWTP Removal for Direct Releases ^a	11-d half-life: 10th percentile		128-d half-life: 10th percentile		11-d half-life: 50th percentile		128-d half-life: 50th percentile	
				Sediment: $\mu\text{g/kg}$	RQ (COC: $1,570 \mu\text{g/kg}$)	Sediment: $\mu\text{g/kg}$	RQ (COC: $1,570 \mu\text{g/kg}$)	Sediment: $\mu\text{g/kg}$	RQ (COC: $1,570 \mu\text{g/kg}$)	Sediment: $\mu\text{g/kg}$	RQ (COC: $1,570 \mu\text{g/kg}$)
Section 2.4.1.4 – Processing of HBCD to produce XPS Foam using XPS Masterbatch (3)	3.1	100,000	0	1430	0.91	1910	1.22	36.4	0.02	48.3	0.03
	3.2		0	163	0.1	414	0.26	4.01	0	8.86	0.01
	3.3		0	3490	2.22	4670	2.97	89.1	0.06	118	0.08
	3.4		0	403	0.26	1020	0.65	9.9	0.01	21.9	0.01
	3.5		N/A	143	0.09	191	0.12	3.64	0	4.83	0
	3.6		N/A	16.3	0.01	41.4	0.03	0.4	0	0.89	0
	3.7		N/A	349	0.22	467	0.3	8.91	0.01	11.8	0.01

The bolded and gray highlighted values denote a risk (RQ≥1) to the aquatic environment where the sediment HBCD concentration exceeds the concentration of concern (COC). N/A indicates sub-scenarios where HBCD is released following treatment via an onsite WWT or POTW (not direct release). The sub-scenarios that are shaded green indicate that these HBCD releases are due to direct release. Sub-scenarios were removed if there were no RQs calculated based on either 10th or 50th percentile sediment concentration predictions that are ≥1.											
Condition of Use	Sub-Scenario	Production Volume (lbs/yr)	% WWTP Removal for Direct Releases ^a	11-d half-life: 10th percentile		128-d half-life: 10th percentile		11-d half-life: 50th percentile		128-d half-life: 50th percentile	
				Sediment: µg/kg	RQ (COC: 1,570 µg/kg)	Sediment: µg/kg	RQ (COC: 1,570 µg/kg)	Sediment: µg/kg	RQ (COC: 1,570 µg/kg)	Sediment: µg/kg	RQ (COC: 1,570 µg/kg)
	3.8		N/A	40.3	0.03	102	0.06	0.99	0	2.19	0
	3.9		N/A	146	0.09	196	0.12	18.3	0.01	24.4	0.02
	3.10		N/A	16.8	0.01	42.7	0.03	2.03	0	4.54	0
	3.11		N/A	358	0.23	479	0.31	44.9	0.03	59.7	0.04
	3.12		N/A	41.4	0.03	105	0.07	5.01	0	11.2	0.01
Section 2.4.1.4 – Processing of HBCD to produce XPS Foam using XPS Masterbatch (3)	3.1	50,000	0	713	0.45	953	0.61	18.2	0.01	24.2	0.02
	3.2		0	81.6	0.05	207	0.13	2	0	4.43	0
	3.3		0	1760	1.12	2350	1.5	44.9	0.03	59.6	0.04
	3.4		0	201	0.13	511	0.33	4.95	0	10.9	0.01
	3.5		N/A	71.3	0.05	95.3	0.06	1.82	0	2.42	0
	3.6		N/A	8.16	0.01	20.7	0.01	0.2	0	0.44	0
	3.7		N/A	176	0.11	235	0.15	4.49	0	5.96	0
	3.8		N/A	20.1	0.01	51.1	0.03	0.5	0	1.09	0
	3.9		N/A	73.2	0.05	97.8	0.06	9.17	0.01	12.2	0.01
	3.10		N/A	8.38	0.01	21.3	0.01	1.01	0	2.27	0
	3.11		N/A	181	0.12	241	0.15	22.6	0.01	30.1	0.02
	3.12		N/A	20.7	0.01	52.7	0.03	2.5	0	5.61	0
Section 2.4.1.4 – Processing of HBCD to produce XPS Foam using XPS Masterbatch (3)	3.1	25,000	0	355	0.23	475	0.3	9.06	0.01	12	0.01
	3.2		0	40.8	0.03	104	0.07	1	0	2.21	0
	3.3		0	881	0.56	1180	0.75	22.5	0.01	29.8	0.02
	3.4		0	101	0.06	256	0.16	2.47	0	5.47	0
	3.5		N/A	35.5	0.02	47.5	0.03	0.91	0	1.2	0
	3.6		N/A	4.08	0	10.4	0.01	0.1	0	0.22	0

The bolded and gray highlighted values denote a risk ($RQ \geq 1$) to the aquatic environment where the sediment HBCD concentration exceeds the concentration of concern (COC). N/A indicates sub-scenarios where HBCD is released following treatment via an onsite WWT or POTW (not direct release). The sub-scenarios that are shaded green indicate that these HBCD releases are due to direct release. Sub-scenarios were removed if there were no RQs calculated based on either 10th or 50th percentile sediment concentration predictions that are ≥ 1 .											
Condition of Use	Sub-Scenario	Production Volume (lbs/yr)	% WWTP Removal for Direct Releases ^a	11-d half-life: 10th percentile		128-d half-life: 10th percentile		11-d half-life: 50th percentile		128-d half-life: 50th percentile	
				Sediment: $\mu\text{g}/\text{kg}$	RQ (COC: 1,570 $\mu\text{g}/\text{kg}$)	Sediment: $\mu\text{g}/\text{kg}$	RQ (COC: 1,570 $\mu\text{g}/\text{kg}$)	Sediment: $\mu\text{g}/\text{kg}$	RQ (COC: 1,570 $\mu\text{g}/\text{kg}$)	Sediment: $\mu\text{g}/\text{kg}$	RQ (COC: 1,570 $\mu\text{g}/\text{kg}$)
	3.7		N/A	88.1	0.06	118	0.08	2.25	0	2.98	0
	3.8		N/A	10.1	0.01	25.6	0.02	0.25	0	0.55	0
	3.9		N/A	36.4	0.02	48.7	0.03	4.57	0	6.07	0
	3.10		N/A	4.19	0	10.7	0.01	0.51	0	1.14	0
	3.11		N/A	90.3	0.06	121	0.08	11.3	0.01	15	0.01
	3.12		N/A	10.3	0.01	26.4	0.02	1.25	0	2.8	0

J.1.2.3 Exposure Scenario 5: Processing of HBCD to Produce EPS Foam from Imported EPS Resin Beads**Table_Apx J-8 Calculated Risk Quotients based on Estimated HBCD Surface Water Concentrations (µg/L) Using PSC (Targeted Sensitivity Analysis Parameters: Production Volume)**

The bolded and gray highlighted values denote a risk (RQ≥1) to the aquatic environment where the surface water concentration (SWC) exceeds the concentration of concern (COC). Underlined SWCs indicate when the predicted surface water release of HBCD for a sub-scenario exceeds the water solubility of HBCD (66 µg/L), resulting in acute, algae or chronic RQs greater than 165, 66, and 158.3, respectively. N/A indicates sub-scenarios where HBCD is released following treatment via an onsite WWT or POTW (not direct release). The sub-scenarios that are shaded green indicate that these HBCD releases are due to direct release.													
Exposure Scenario	Sub-Scenario	Production Volume (lbs/yr)	% WWTP Removal for Direct Releases ^a	10th percentile					50th percentile				
				1-day SWC (µg/L)	RQs based on 1-d SWC		21-day SWC: µg/L	RQs based on 21-d SWC	1-day SWC (µg/L)	RQs based on 1-d SWC		21-day SWC: µg/L	RQs based on 21-d SWC
					Acute RQ (COC: 0.4 µg/L)	Algae RQ (COC: 1 µg/L)				Chronic RQ (COC: 0.417 µg/L)	Acute RQ (COC: 0.4 µg/L)		
Section 2.4.1.6 – Processing of HBCD to produce EPS Foam from Imported EPS Resin Beads (5)	5.1	100,000	0	<u>2900.00</u>	7250.00	2900.00	<u>172.00</u>	412.47	<u>76.60</u>	191.50	76.60	3.67	8.80
	5.2		N/A	<u>290.00</u>	725.00	290.00	17.20	41.25	7.66	19.15	7.66	0.37	0.88
	5.3		N/A	<u>297.00</u>	742.50	297.00	17.70	42.45	38.50	96.25	38.50	1.88	4.51
	5.4		0	<u>358.00</u>	895.00	358.00	<u>140.00</u>	335.73	8.78	21.95	8.78	2.94	7.05
	5.5		N/A	35.80	89.50	35.80	14.00	33.57	0.88	2.19	0.88	0.29	0.70
	5.6		N/A	36.80	92.00	36.80	14.40	34.53	4.44	11.10	4.44	1.51	3.62
	5.7		0	<u>3960.00</u>	9900.00	3960.00	<u>235.00</u>	563.55	<u>105.00</u>	262.50	105.00	5.01	12.01
	5.8		N/A	<u>396.00</u>	990.00	396.00	23.50	56.35	10.50	26.25	10.50	0.50	1.20
	5.9		N/A	<u>406.00</u>	1015.00	406.00	24.20	58.03	52.50	131.25	52.50	2.57	6.16
	5.10		0	<u>489.00</u>	1222.50	489.00	<u>191.00</u>	458.03	12.00	30.00	12.00	4.01	9.62
	5.11		N/A	48.90	122.25	48.90	19.10	45.80	1.20	3.00	1.20	0.40	0.96
	5.12		N/A	50.30	125.75	50.30	19.70	47.24	6.06	15.15	6.06	2.06	4.94
Section 2.4.1.6 – Processing of HBCD	5.1	50,000	0	<u>2880.00</u>	7200.00	2880.00	<u>157.00</u>	376.50	<u>76.60</u>	191.50	76.60	3.66	8.78
	5.2		N/A	<u>289.00</u>	722.50	289.00	15.70	37.65	7.66	19.15	7.66	0.37	0.88
	5.3		N/A	<u>296.00</u>	740.00	296.00	16.20	38.85	38.50	96.25	38.50	1.86	4.46

The bolded and gray highlighted values denote a risk ($RQ \geq 1$) to the aquatic environment where the surface water concentration (SWC) exceeds the concentration of concern (COC). Underlined SWCs indicate when the predicted surface water release of HBCD for a sub-scenario exceeds the water solubility of HBCD ($66 \mu\text{g/L}$), resulting in acute, algae or chronic RQs greater than 165, 66, and 158.3, respectively. N/A indicates sub-scenarios where HBCD is released following treatment via an onsite WWT or POTW (not direct release). The sub-scenarios that are shaded green indicate that these HBCD releases are due to direct release.

Exposure Scenario	Sub-Scenario	Production Volume (lbs/yr)	% WWTP Removal for Direct Releases ^a	10th percentile					50th percentile				
				1-day SWC ($\mu\text{g/L}$)	RQs based on 1-d SWC		21-day SWC: $\mu\text{g/L}$	RQs based on 21-d SWC	1-day SWC ($\mu\text{g/L}$)	RQs based on 1-d SWC		21-day SWC: $\mu\text{g/L}$	RQs based on 21-d SWC
					Acute RQ (COC: $0.4 \mu\text{g/L}$)	Algae RQ (COC: $1 \mu\text{g/L}$)		Chronic RQ (COC: $0.417 \mu\text{g/L}$)		Acute RQ (COC: $0.4 \mu\text{g/L}$)	Algae RQ (COC: $1 \mu\text{g/L}$)		Chronic RQ (COC: $0.417 \mu\text{g/L}$)
to produce EPS Foam from Imported EPS Resin Beads (5)	5.4	25,000	0	<u>179.00</u>	447.50	179.00	<u>69.90</u>	167.63	4.39	10.98	4.39	1.47	3.53
	5.5		N/A	17.90	44.75	17.90	6.99	16.76	0.44	1.10	0.44	0.15	0.35
	5.6		N/A	18.40	46.00	18.40	7.21	17.29	2.22	5.55	2.22	0.76	1.81
	5.7		0	<u>3940.00</u>	9850.00	3940.00	<u>215.00</u>	515.59	<u>105.00</u>	262.50	105.00	5.00	11.99
	5.8		N/A	<u>392.00</u>	980.00	392.00	19.90	47.72	10.50	26.25	10.50	0.50	1.20
	5.9		N/A	<u>402.00</u>	1005.00	402.00	20.50	49.16	52.50	131.25	52.50	2.54	6.09
	5.10		0	<u>245.00</u>	612.50	245.00	<u>95.50</u>	229.02	5.99	14.98	5.99	2.01	4.82
	5.11		N/A	23.20	58.00	23.20	8.27	19.83	0.60	1.50	0.60	0.22	0.52
	5.12		N/A	23.80	59.50	23.80	8.49	20.36	3.03	7.58	3.03	1.03	2.47
Section 2.4.1.6 – Processing of HBCD to produce EPS Foam from Imported EPS Resin Beads (5)	5.1	25,000	0	<u>2880.00</u>	7200.00	2880.00	<u>151.00</u>	362.11	<u>76.60</u>	191.50	76.60	3.66	8.78
	5.2		N/A	<u>288.00</u>	720.00	288.00	15.10	36.21	7.66	19.15	7.66	0.37	0.88
	5.3		N/A	<u>295.00</u>	737.50	295.00	15.50	37.17	38.50	96.25	38.50	1.85	4.44
	5.4		0	<u>89.70</u>	224.25	89.70	35.00	83.93	2.20	5.50	2.20	0.74	1.76
	5.5		N/A	8.97	22.43	8.97	3.50	8.39	0.22	0.55	0.22	0.07	0.18
	5.6		N/A	9.21	23.03	9.21	3.61	8.66	1.11	2.78	1.11	0.38	0.91
	5.7		0	<u>3930.00</u>	9825.00	3930.00	<u>205.00</u>	491.61	<u>105.00</u>	262.50	105.00	4.99	11.97
	5.8		N/A	7.29	18.23	7.29	1.86	4.46	0.94	2.35	0.94	0.23	0.55
	5.9		N/A	<u>402.00</u>	1005.00	402.00	20.30	48.68	52.50	131.25	52.50	2.53	6.07
	5.10		0	<u>122.00</u>	305.00	122.00	47.50	113.91	2.98	7.45	2.98	1.00	2.40

The bolded and gray highlighted values denote a risk ($RQ \geq 1$) to the aquatic environment where the surface water concentration (SWC) exceeds the concentration of concern (COC). Underlined SWCs indicate when the predicted surface water release of HBCD for a sub-scenario exceeds the water solubility of HBCD ($66 \mu\text{g/L}$), resulting in acute, algae or chronic RQs greater than 165, 66, and 158.3, respectively. N/A indicates sub-scenarios where HBCD is released following treatment via an onsite WWT or POTW (not direct release). The sub-scenarios that are shaded green indicate that these HBCD releases are due to direct release.

Exposure Scenario	Sub-Scenario	Production Volume (lbs/yr)	% WWTP Removal for Direct Releases ^a	10th percentile					50th percentile				
				1-day SWC ($\mu\text{g/L}$)	RQs based on 1-d SWC		21-day SWC: $\mu\text{g/L}$	RQs based on 21-d SWC	1-day SWC ($\mu\text{g/L}$)	RQs based on 1-d SWC		21-day SWC: $\mu\text{g/L}$	RQs based on 21-d SWC
					Acute RQ (COC: $0.4 \mu\text{g/L}$)	Algae RQ (COC: $1 \mu\text{g/L}$)		Chronic RQ (COC: $0.417 \mu\text{g/L}$)		Acute RQ (COC: $0.4 \mu\text{g/L}$)	Algae RQ (COC: $1 \mu\text{g/L}$)		Chronic RQ (COC: $0.417 \mu\text{g/L}$)
	5.11		N/A	11.50	28.75	11.50	4.12	9.88	0.30	0.75	0.30	0.10	0.24
	5.12		N/A	11.80	29.5	11.8	4.23	10.14	1.51	3.775	1.51	0.51	1.23

Table_Apx J-9 Calculated Risk Quotients based on Estimated HBCD Sediment Concentrations ($\mu\text{g}/\text{kg}$) Using PSC (Targeted Sensitivity Analysis Parameters: Production Volume)

The bolded and gray highlighted values denote a risk ($RQ \geq 1$) to the aquatic environment where the sediment HBCD concentration exceeds the concentration of concern (COC). N/A indicates sub-scenarios where HBCD is released following treatment via an onsite WWT or POTW (not direct release). The sub-scenarios that are shaded green indicate that these HBCD releases are due to direct release. Sub-scenarios were removed if there were no RQs calculated based on either 10th or 50th percentile sediment concentration predictions that are ≥ 1 .											
Condition of Use	Sub-Scenario	Production Volume (lbs/yr)	% WWTP Removal for Direct Releases ^a	11-d half-life: 10th percentile		128-d half-life: 10th percentile		11-d half-life: 50th percentile		128-d half-life: 50th percentile	
				Sediment: $\mu\text{g}/\text{kg}$	RQ (COC: 1,570 $\mu\text{g}/\text{kg}$)	Sediment: $\mu\text{g}/\text{kg}$	RQ (COC: 1,570 $\mu\text{g}/\text{kg}$)	Sediment: $\mu\text{g}/\text{kg}$	RQ (COC: 1,570 $\mu\text{g}/\text{kg}$)	Sediment: $\mu\text{g}/\text{kg}$	RQ (COC: 1,570 $\mu\text{g}/\text{kg}$)
Section 2.4.1.6 – Processing of HBCD to produce EPS Foam from Imported EPS Resin Beads (5)	5.1	100,000	0	165000	105.1	417000	265.61	4050	2.58	8910	5.68
	5.2		N/A	16500	10.51	41700	26.56	405	0.26	891	0.57
	5.3		N/A	16900	10.76	42900	27.32	2050	1.31	4560	2.9
	5.4		0	137000	87.26	356000	226.75	3340	2.13	7560	4.82
	5.5		N/A	13700	8.73	35600	22.68	334	0.21	756	0.48
	5.6		N/A	14100	8.98	36800	23.44	1690	1.08	3880	2.47
	5.7		0	225000	143.31	568000	361.78	5530	3.52	12200	7.77
	5.8		N/A	22500	14.33	56800	36.18	553	0.35	1220	0.78
	5.9		N/A	23100	14.71	58600	37.32	2800	1.78	6230	3.97
	5.10		0	187000	119.11	487000	310.19	4560	2.9	10300	6.56
	5.11		N/A	18700	11.91	48700	31.02	456	0.29	1030	0.66
	5.12		N/A	19200	12.23	50200	31.97	2330	1.48	5300	3.38
Section 2.4.1.6 – Processing of HBCD to produce EPS Foam from Imported EPS Resin Beads (5)	5.1	50,000	0	102000	64.97	231000	147.13	2560	1.63	5050	3.22
	5.2		N/A	10300	6.56	23100	14.71	256	0.16	505	0.32
	5.3		N/A	10500	6.69	23800	15.16	1290	0.82	2590	1.65
	5.4		0	68500	43.63	178000	113.38	1670	1.06	3780	2.41
	5.5		N/A	6850	4.36	17800	11.34	167	0.11	378	0.24
	5.6		N/A	7030	4.48	18400	11.72	846	0.54	1940	1.24
	5.7		0	140000	89.17	316000	201.27	3500	2.23	6900	4.39
	5.8		N/A	13600	8.66	29700	18.92	341	0.22	655	0.42
	5.9		N/A	13900	8.85	30600	19.49	1720	1.1	3350	2.13

The bolded and gray highlighted values denote a risk (RQ≥1) to the aquatic environment where the sediment HBCD concentration exceeds the concentration of concern (COC). N/A indicates sub-scenarios where HBCD is released following treatment via an onsite WWT or POTW (not direct release). The sub-scenarios that are shaded green indicate that these HBCD releases are due to direct release. Sub-scenarios were removed if there were no RQs calculated based on either 10th or 50th percentile sediment concentration predictions that are ≥1.											
Condition of Use	Sub-Scenario	Production Volume (lbs/yr)	% WWTP Removal for Direct Releases ^a	11-d half-life: 10th percentile		128-d half-life: 10th percentile		11-d half-life: 50th percentile		128-d half-life: 50th percentile	
				Sediment: µg/kg	RQ (COC: 1,570 µg/kg)	Sediment: µg/kg	RQ (COC: 1,570 µg/kg)	Sediment: µg/kg	RQ (COC: 1,570 µg/kg)	Sediment: µg/kg	RQ (COC: 1,570 µg/kg)
	5.10		0	93500	59.55	243000	154.78	2280	1.45	5160	3.29
	5.11		N/A	9350	5.96	24300	15.48	228	0.15	516	0.33
	5.12		N/A	9600	6.11	25100	15.99	1160	0.74	2650	1.69
Section 2.4.1.6 – Processing of HBCD to produce EPS Foam from Imported EPS Resin Beads (5)	5.1	25,000	0	91800	58.47	156000	99.36	2340	1.49	3600	2.29
	5.2		N/A	9180	5.85	15600	9.94	234	0.15	360	0.23
	5.3		N/A	9420	6	16000	10.19	1180	0.75	1830	1.17
	5.4		0	34300	21.85	89200	56.82	836	0.53	1890	1.2
	5.5		N/A	3430	2.18	8920	5.68	83.6	0.05	189	0.12
	5.6		N/A	3520	2.24	9200	5.86	424	0.27	972	0.62
	5.7		0	125000	79.62	212000	135.03	3190	2.03	4920	3.13
	5.8		N/A	1800	1.15	4690	2.99	216	0.14	495	0.32
	5.9		N/A	12900	8.22	21900	13.95	1610	1.03	2500	1.59
	5.10		0	46600	29.68	121000	77.07	1140	0.73	2570	1.64
	5.11		N/A	4660	2.97	12100	7.71	114	0.07	257	0.16
5.12	N/A	4780	3.04	12500	7.96	575	0.37	1320	0.84		

J.1.2.4 Trophic Transfer: Risk Quotients for Terrestrial Mammals based on KABAM

Table_Apx J-10. Chemical Properties: Input Parameters for KABAM (v1) based on Estimated HBCD Surface Water and Sediment Concentrations (µg/kg) Using PSC

Condition of Use	Sub-Scenario	Production Volume (lbs/yr)	% WWTP Removal for Direct Releases	Physiochemical Properties		21-day SWC: µg/L: 10th percentile	128-d half-life: 10th percentile	21-day SWC: µg/L: 50th percentile	128-d half-life: 50th percentile
				Log Kow	Koc (L/kg OC)	Surface Water Concentration: Dissolved Fraction (µg/L)	Pore Water Concentration (µg/L)	Surface Water Concentration: Dissolved Fraction (µg/L)	Pore Water Concentration (µg/L)
Processing: Manufacturing of XPS Foam using XPS Masterbatch	3.3	100,000	75	5.62	100,000	1.067	0.292	0.0264	0.0074
		50,000	75	5.62	100,000	0.538	0.147	0.0133	0.00373
		25,000	75	5.62	100,000	0.269	0.0735	0.00667	0.00186
Processing: Manufacturing of EPS Foam from Imported EPS Resin beads	5.7	100,000	75	5.62	100,000	44.353	35.5	0.946	0.758
		50,000	75	5.62	100,000	40.56902	19.7	0.946	0.43
		25,000	75	5.62	100,000	38.828185	13.3	0.946	0.307

Table_Apx J-11. HBCD Hazard Data: Input Parameters for KABAM (v1)

Avian Toxicity Data					Mammalian Toxicity Data				
Avian Species	Avian NOAEC (mg/kg-diet)	Endpoint	References	Data Evaluation Score	Mammalian Species	Mammalian LOEC (mg/kg-bw)	Endpoint	References	Data Evaluation Score
Japanese quail	125	Development	(MOEJ 2009)	High	Rat	10	Thyroid	(Ema et al., 2008)	High

Table_Apx J-12. Calculated Risk Quotients based on KABAM (v1) based on Estimated HBCD Surface Water and Sediment Concentrations ($\mu\text{g}/\text{kg}$) Using PSC

The bolded values denote a risk ($\text{RQ} \geq 1$) to the terrestrial environment, based on input parameters for KABAM (v1).

Wildlife Species		10th Percentile Surface Water and Sediment Concentrations						50th Percentile Surface Water and Sediment Concentrations					
		(COU 3.3) Processing: Manufacturing of XPS Foam using XPS Masterbatch			(COU 5.7) Processing: Manufacturing of EPS Foam from Imported EPS Resin beads			(COU 3.3) Processing: Manufacturing of XPS Foam using XPS Masterbatch			(COU 5.7) Processing: Manufacturing of EPS Foam from Imported EPS Resin beads		
		Production Volume (lbs/year)											
		100,000	50,000	25,000	100,000	50,000	25,000	100,000	50,000	25,000	100,000	50,000	25,000
Mammalian Species	fog/water shrew	0.6	0.3	0.1	23.6	21.2	20.1	0.0	0.0	0.0	0.5	0.5	0.5
	rice rat/star-nosed mole	0.8	0.4	0.2	34.4	31.0	29.4	0.0	0.0	0.0	0.7	0.7	0.7
	small mink	2.0	1.0	0.5	84.3	75.9	72.1	0.0	0.0	0.0	1.8	1.8	1.8
	large mink	2.2	1.1	0.5	93.1	83.8	79.6	0.1	0.0	0.0	2.0	2.0	1.9
	small river otter	2.4	1.2	0.6	100.2	90.2	85.7	0.1	0.0	0.0	2.1	2.1	2.1
	large river otter	6.2	3.1	1.6	264.7	238.6	226.8	0.2	0.1	0.0	5.6	5.6	5.5

J.1.3 Terrestrial Environment

J.1.3.1 HIOAC Predicted Soil Concentrations via Air Deposition

Table_Apx J-13. Calculated Risk Quotients based on Estimated HBCD Soil Concentrations ($\mu\text{g}/\text{kg}$) Using HIOAC

There are no instances of risk quotients (RQ) that are ≥ 1 for the terrestrial soil environment (indicating risk) where the predicted soil HBCD concentration exceeds the hazard effect concentration for earthworms (173,000 $\mu\text{g}/\text{kg}$).							
Exposure Scenario	Sub-Scenario	Fugitive Range		Stack Range		Incineration Range	
		Soil Concentration ($\mu\text{g}/\text{kg}$)	RQ	Soil Concentration ($\mu\text{g}/\text{kg}$)	RQ	Soil Concentration ($\mu\text{g}/\text{kg}$)	RQ
Section 2.4.1.2 – Repackaging of Import Containers (1)	Fenceline	1.28E-01	7.40E-07	6.66E-02	3.85E-07	3.42E-03	1.98E-08
	Community	3.64E-03	2.10E-08	3.04E-03	1.76E-08	1.29E-03	7.46E-09
Section 2.4.1.3 – Compounding of Polystyrene Resin to Produce XPS Masterbatch (2)	Fenceline	2.05E-04	1.18E-09	1.12E-04	6.47E-10	N/A	N/A
	Community	5.32E-06	3.08E-11	4.45E-06	2.57E-11	N/A	N/A
Section 2.4.1.4 – Processing of HBCD to produce XPS Foam using XPS Masterbatch (3)	Fenceline	2.05E-03	1.18E-08	1.19E-03	6.88E-09	N/A	N/A
	Community	4.21E-05	2.43E-10	3.52E-05	2.03E-10	N/A	N/A
Section 2.2.5 – Processing of HBCD to produce XPS Foam using HBCD Powder (4)	Fenceline	2.58E-04	1.49E-09	7.46E-03	4.31E-08	5.98E-04	3.46E-09
	Community	5.30E-06	3.06E-11	3.80E-04	2.20E-09	3.35E-04	1.94E-09
Section 2.4.1.6 – Processing of HBCD to produce EPS Foam from Imported EPS Resin Beads (5)	Fenceline	1.34E-01	7.75E-07	7.00E-02	4.05E-07	3.22E-02	1.86E-07
	Community	3.64E-03	2.10E-08	3.05E-03	1.76E-08	1.03E-02	5.95E-08
Section 2.4.1.7 – Processing of HBCD to produce SIPs and Automobile Replacement Parts from XPS/EPS Foam (6)	Fenceline	6.03E-03	3.49E-08	3.15E-03	1.82E-08	2.03E-02	1.17E-07
	Community	1.64E-04	9.48E-10	1.37E-04	7.92E-10	6.48E-03	3.75E-08
Section 2.4.1.9 – Installation of XPS/EPS Foam Insulation in	Fenceline	2.05E-04	1.18E-09	N/A	N/A	9.68E-04	5.60E-09
	Community	4.81E-06	2.78E-11	N/A	N/A	1.89E-04	1.09E-09

There are no instances of risk quotients (RQ) that are ≥ 1 for the terrestrial soil environment (indicating risk) where the predicted soil HBCD concentration exceeds the hazard effect concentration for earthworms (173,000 $\mu\text{g}/\text{kg}$).							
Exposure Scenario	Sub-Scenario	Fugitive Range		Stack Range		Incineration Range	
		Soil Concentration ($\mu\text{g}/\text{kg}$)	RQ	Soil Concentration ($\mu\text{g}/\text{kg}$)	RQ	Soil Concentration ($\mu\text{g}/\text{kg}$)	RQ
Residential, Public, and Commercial Buildings, and Other Structures (8)							
Section 2.4.1.10 – Demolition of XPS/EPS Foam Insulation Products in Residential, Public and Commercial Buildings, and Other Structures (9)	Fenceline	5.27E-04	3.05E-09	N/A	N/A	N/A	N/A
	Community	1.08E-05	6.24E-11	N/A	N/A	N/A	N/A
Section 2.4.1.11 – Recycling of EPS Foam and Reuse of XPS Foam (10)	Fenceline	1.24E-04	7.17E-10	7.20E-05	4.16E-10	2.14E-05	1.24E-10
	Community	2.54E-06	1.47E-11	2.14E-06	1.24E-11	4.50E-06	2.60E-11
Section 2.4.1.12 – Formulation of Flux/Solder Pastes (11)	Fenceline	4.99E-04	2.88E-09	6.88E-03	3.98E-08	N/A	N/A
	Community	1.65E-05	9.54E-11	2.49E-04	1.44E-09	N/A	N/A
Section 2.4.1.13 – Use of Flux/Solder Pastes (12)	Fenceline	N/A	N/A	N/A	N/A	2.37E-05	1.37E-10
	Community	N/A	N/A	N/A	N/A	5.09E-06	2.94E-11

Appendix K Human Health Risk

K.1 Targeted Sensitivity Analysis

A targeted sensitivity analyses on the impact of import volumes on environmental risk estimates was performed. The exposure scenarios considered in the sensitivity analysis represent the exposure scenarios that resulted in the highest estimates of releases on a daily basis and include scenarios that rely on both industry data and OECD ESDs.

Manufacturing of EPS Foam from Imported EPS Resin beads

Estimation of the risk is below the benchmark MOE for all lifestages only following acute exposure from the highest exposure sub-scenario (5.7) assuming 100,000 lbs PV and 0% WWT removal. Reduced PV has essentially no effect on acute exposures and associated risk estimates. Therefore, sensitivity analysis demonstrates that differing assumptions of production volume has minimal effect on the risk estimate conclusions for the highly exposed population.

Table_Apx K-1. Targeted Sensitivity Analysis Based on Production Volume for the Highly Exposed Population Following Acute Exposure

SCENARIO NAME	Production Volume (lbs / year)	1- <2 years	2- <3 years	3- <6 years	6 - <11 years	11- <16 years	16- <70 years
5.7 Manufacturing of EPS Foam from Imported EPS Resin beads (Highest Exposure)	100,000	14	17	18	24	39	21
5.7 Manufacturing of EPS Foam from Imported EPS Resin beads (Highest Exposure)	50,000	14	17	19	24	40	21
5.7 Manufacturing of EPS Foam from Imported EPS Resin beads (Highest Exposure)	25,000	14	17	19	24	40	21
MOEs represent risk from aggregate exposure values from fish ingestion ADR and background general population exposure.							

Appendix L Dermal Absorption Estimate Method Comparison

L.1 Fraction Absorbed Method As Used in Risk Evaluation

$$D_{exp} = S \times (Q_u \times f_{abs}) \times Y_{derm} \times FT$$

Where:

S = Surface area of contact (cm²)

Q_u = Quantity remaining on the skin (mg/cm²-event)

f_{abs} = **Fraction absorbed through the skin**

Y_{derm} = Weight fraction of the chemical of interest in the liquid (0 ≤ Y_{derm} ≤ 1)

FT = Frequency of events (integer number per day) - assumed to be 1

Based on three identified studies examining dermal absorption, the highest fractional absorbed value (f_{abs}) was used and applied to all dermal exposure estimates (6.5% from ([Abdallah et al. 2015](#))).

$$AAD = PDR \times 0.065 \div 80kg = 2.52 \text{ mg/kg}$$

Characterization	Y _{derm}	Q _u	M = Q _u x S	Frequency of Events	Potential Dose Rate	Acute Absorbed Dose
	wt fraction	mg/cm ² -event	mg/event	FT	D _{exp} (mg/day)	AAD _{HSCD} (mg/kg-day)
High-end: 90th percentile						
Central Tendency: Median	1.0		3,100	1	3,100	2.52

Figure_Apx L-1. Excerpt of Dermal Exposure Results from Repackaging of Import Containers

L.2 Permeability Method

K_p is a constant with units cm/hr.

K_p × ρ (density in g/cm³) = maximum flux (J_{max}, neat) in g/(cm²-hr).

K_p × maximum solubility (in g/cm³) = maximum flux (J_{max}, in solvent) in g/(cm²-hr).

K_p × experimental concentration (in g/cm³) = steady state flux (J_{ss}, in solvent) in g/(cm²-hr).

According to ([Kissel 2011](#)), one should always consider flux instead of simple fractional absorption when possible in order to account for surface loading and limited time for absorption.

Abdallah et al., 2015

From ([Abdallah et al. 2015](#)), the highest reported value of K_p in acetone = 2.74E-4 cm/hr (for α diastereomer).

J_{ss} (steady state flux) = 1.33 ng/(cm²-hr) (or 1.33E-9 g/(cm²-hr)).

Flux can also be calculated from % absorbed dose if the three variables in the equation are known: the amount of chemical added to the surface, the surface area, and the time allowed for penetration ([Kissel 2011](#)).

J_{ss} = (% absorbed) × (Q_u, quantity deposited (ng/cm²)) × duration of exposure

Based on the experimental methods of ([Abdallah et al. 2015](#)),

$J_{ss} = 0.065 \times \left(\frac{500 \text{ ng}}{1 \text{ cm}^2} \right) \div 24 \text{ hr} = 1.35 \text{ ng}/(\text{cm}^2 - \text{hr})$, almost identical to the provided value.

Based on the formula, $J_{ss} = K_p * C$ (concentration), with $C = 500 \text{ ng}/100 \mu\text{l} = 5 \text{ ng}/\mu\text{l}$.
 $J_{ss} = 2.74\text{E-}4 \times 5 \text{ ng}/\mu\text{l} = 1.5 \text{ ng}/(\text{cm}^2\text{-hr})$, which is also almost identical in value.

Roper et al., 2007

Roper et al., (2007) reports a much lower % absorbed dose value of 0.01%, however when considering the amount of chemical applied, the calculated steady state flux (J_{ss}) = 4.2 ng/(cm²-hr), over 3x higher than the flux from Abdallah 2015.

$$J_{ss} = 0.001 \times \left(\frac{1 \text{ mg}}{1 \text{ cm}^2} \right) \div 24 \text{ hr} \times 1\text{E} + 6 \frac{\text{ng}}{\text{mg}} = 4.2 \frac{\text{ng}}{\text{cm}^2\text{-hr}}$$

$$K_p = J_{ss}/C;$$

$$C = \frac{640 \mu\text{g}}{30 \mu\text{l}} = 21.3 \mu\text{g}/\mu\text{l} \text{ (as 5 applications of 6ul)} = 21333333 \text{ ng}/\text{ml};$$

$$K_p = \frac{4.2 \text{ ng}/(\text{cm}^2 - \text{hr})}{21333333 \text{ ng}/\text{ml}} = 1.97\text{E-}7 \text{ cm}/\text{hr}$$

This value could potentially be underestimating flux, because absorption continues after removal of load (Frasch et al. 2014), especially for non-volatile compounds. Therefore, it might be better to assume that the dermal delivery load could contribute additionally to systemic absorption over time. (Roper et al. 2007) estimated 34.6% of the original dose initially retained in the skin, with 1.35% dermal delivery remaining after 24h following washing and drying. Additionally, the K_p value may be inaccurate, as a specific concentration was not provided and instead needed to be approximated by adding 5 separate aliquots of HBCD dissolved in acetone.

L.3 Method Comparison

L.3.1 Occupational Exposure Using Flux

Because dermal load may contribute to additional absorption over time, it is reasonable to use 24hr as a higher-end estimate on the time duration variable to account for continued absorption.

ChemSTEER uses a value of 1070 cm² as the surface area of both hands for calculating exposure.

Based on these two factors, $4.2 \text{ ng}/(\text{cm}^2\text{-hr}) \times 1070 \text{ cm}^2 \times 24 \text{ hr} = 107856 \text{ ng} = 107.86 \mu\text{g} = 0.108 \text{ mg}$ as the amount of HBCD absorbed at steady-state flux.

$\text{PDR} = 0.108 \text{ mg} / 80 \text{ kg} = 1.35\text{E-}03 \text{ mg}/\text{kg}$, which is over 1800-fold less than the amount of HBCD absorbed by the fraction absorbed method (see Figure_Apx L-1).

One cannot calculate J_{max} , maximum flux, without the maximum solubility of HBCD in acetone.

According to a commercial SDS,

(<https://www.sigmaaldrich.com/catalog/product/aldrich/144762?lang=en®ion=US>) and ChemicalBook.com (https://www.chemicalbook.com/ChemicalProductProperty_EN_CB7363333.htm), the solubility of HBCD in acetone is 25 mg/ml. The permeability of HBCD would be significantly lower in water, however permeability could be higher in certain formulations or through oily skin (Pawar et al., 2016).

Using the higher K_p value of the two studies (and the one directly measured, from ([Abdallah et al. 2015](#)), we can calculate J_{max} .

K_p in acetone = $2.74E-4$ cm/hr;

$K_p \times 25$ mg/ml = $6.85E-3$ mg/(cm²-hr) or 6.85 μg/(cm²-hr). This is over 1000x higher than the steady state flux J_{ss} calculated from either study, indicating that testing a higher concentration of HBCD would have resulted in greater measured flux.

6.85 μg/(cm²-hr) \times 1070 cm² \times 24 hr = $1.76E5$ μg = 175.9 mg absorbed.

PDR = 175.9 mg / 80 kg = 2.2 mg/kg, which is very similar to the originally estimated dose of 2.52 mg/kg (Figure_Apx L-1). Therefore, while both of these calculations represent very high-end conservative estimates, it can be concluded that the upper bound of dermal absorption estimates is consistent between the fraction absorbed and permeability methods.

L.3.2 General Population Considerations

Use of fractional absorption is appropriate for general population or consumer exposure estimates, where exposure is assumed to be continuous and sustained over time. In that case, there would be an infinite time variable and the flux rate would be irrelevant. Therefore, the steady state fraction absorbed is suitable for this use.

UNITED STATES COURT OF APPEALS FOR THE NINTH CIRCUIT

ALASKA COMMUNITY ACTION ON TOXICS,

Petitioner,

v.

UNITED STATES ENVIRONMENTAL
PROTECTION AGENCY, and ANDREW
WHEELER, Administrator, United States
Environmental Protection Agency,

Respondents.

No. _____

PROOF OF SERVICE

I certify that on October 16, 2020, I filed the Petition for Review, Exhibits 1 and 2 to the Petition, and Petitioner's Rule 26.1 Corporate Disclosure Statement with the Clerk of the Court for the United States Court of Appeals for the Ninth Circuit by using the appellate CM/ECF system.

I further certify that on October 16, 2020, copies of the concurrently filed Petition for Review, Exhibits 1 and 2 to the Petition, and Petitioner's Rule 26.1 Corporate Disclosure Statement will be emailed and sent via first-class mail, to counsel for Respondents at the following addresses:

Joseph E. Cole
cole.josephe@epa.gov
Associate General Counsel
Pesticides and Toxic Substances Law Office
Office of General Counsel
U.S. Environmental Protection Agency
USEPA Headquarters
William Jefferson Clinton Building
1200 Pennsylvania Avenue, N.W.
Mail Code: 2333A
Washington, DC 20460

Correspondence Control Unit
Office of General Counsel (2311)
U.S. Environmental Protection Agency
1200 Pennsylvania Avenue, N.W.
Washington, DC 20460

s/ Tosh Sagar
Tosh Sagar
Earthjustice
1001 G St. NW, Suite 1000
Washington, DC 20001
T: (202) 667-4500
tsagar@earthjustice.org