

UNITED STATES DISTRICT COURT
WESTERN DISTRICT OF TEXAS

FILED

JUN 16 2005

CLERK, U.S. DISTRICT COURT
WESTERN DISTRICT OF TEXAS
BY _____
DEPUTY CLERK

UNITED STATES OF AMERICA,)
Plaintiff,)
)
and)
the States of Colorado, Louisiana,)
New Jersey..Oklahoma and Texas,)
Plaintiff-Interveners,)
)
v.)
)
Valero Refining Company, et al,)
and Tesoro Refining and Marketing)
Corporation,)
)
Defendants.)
-----)

CIVIL ACTION NO.

SA05CA0569

RF

CONSENT DECREE

WHEREAS, Plaintiff, the United States of America (hereinafter "Plaintiff" or "the United States"), on behalf of the United States Environmental Protection Agency (herein, "EPA"), has simultaneously filed a Complaint against and lodged this Consent Decree with Valero Refining Company - California, Valero Refining Company - New Jersey, Valero Refining Company - Louisiana, Valero Refining Company - New Orleans, Valero Refining Company - Oklahoma, Valero Refining - Texas, L.P., Ultramar, Inc., TPI Petroleum, Inc., Colorado Refining Company and Diamond Shamrock Refining Company, L.P. (hereinafter individually and collectively, "Valero") and with Tesoro Refining and Marketing Company (hereinafter "Tesoro") (hereinafter collectively the "Companies" or "Defendants"), for alleged

Handwritten mark: a large checkmark with the number '1' above it and some illegible scribbles to the right.

environmental violations at petroleum refineries owned and operated by the Companies and/or under the mobile source programs;

WHEREAS, the United States has initiated a nationwide, broad-based compliance and enforcement initiative involving the petroleum refining industry;

WHEREAS, the United States' Complaint alleges that the Companies have been and are

WHEREAS, the Companies have not answered or otherwise responded, and need not answer or otherwise respond, to the Complaint in light of the settlement memorialized in this Consent Decree;

WHEREAS, the Companies have waived any applicable federal or state requirements of statutory notice of the alleged violations;

WHEREAS, the Companies have denied and continue to deny the violations alleged in the Complaints and maintain their defenses to the alleged violations;

WHEREAS, by entering into this Consent Decree, the Companies have indicated that they are committed to pro-actively resolving the allegations of environmental concerns related to their operations raised in the Complaints;

WHEREAS, the Companies have, in the interest of settlement, agreed to undertake installation of significant air pollution control equipment and enhancements to air pollution management practices at their refineries to reduce air emissions;

WHEREAS, the parties agree that the installation of equipment and implementation of controls pursuant to this Consent Decree will achieve major improvements in air quality control,

and also that certain actions that the Companies have agreed to take are expected to achieve advances in technology and other methods of air pollution control;

WHEREAS, projects undertaken pursuant to this Consent Decree are for the purposes of abating or controlling atmospheric pollution or contamination by removing, reducing, or preventing the creation of emission of pollutants ("pollution control facilities") and as such, may be considered for certification as pollution control facilities by federal, state or local authorities;

WHEREAS, in anticipation of entry of this Consent Decree, Valero has commenced or completed installation, operation and/or implementation of certain emission control technologies or work practices at various refineries governed by this Consent Decree;

WHEREAS, EPA agrees that under the recently issued PSD Rules and PSDINSR Regulations that identify and address "Clean Units", see 67 Fed. Reg. 80186 et seq., units that accept the following emission limits under this Consent Decree may be considered as "Clean Units" with respect to the identified pollutants:

- For FCCUs – 20 ppmvd NO_x at 0% O₂ on a 365-day rolling average basis
- 25 ppmvd SO₂ at 0% on a 365-day rolling average basis
- 100 ppmvd CO at 0% on a 365-day rolling average basis
- 0.5 pounds of PM per 1,000 pounds of coke burned on a 3-hour average basis

For Heaters and Boilers - 0.020 lbs/MMBTU NO_x;

WHEREAS, the States of Colorado, Louisiana, New Jersey, Oklahoma and Texas have filed Complaints in Intervention ("Plaintiff-Intervener"), alleging that the Companies were and are in violation of the applicable Clean Air Act State Implementation Plan ("SIP"), and other state environmental statutory and regulatory requirements;

WHEREAS, the United States, Plaintiff-Interveners, and the Companies have consented to entry of this Consent Decree without trial of any issues;

WHEREAS, the United States, Plaintiff-Interveners, and Companies have agreed that settlement of this action is in the best interest of the parties and in the public interest, and that entry of this Consent Decree without further litigation is the most appropriate means of resolving this matter,

NOW, THEREFORE, without any admission of fact or law, and without any admission of the violations alleged in the Complaints, it is hereby ORDERED AND DECREED as follows:

I. JURISDICTION AND VENUE

1. The Complaints state a claim upon which relief can be granted against the Companies under Sections 113, 167 and 211 of the Clean Air Act, 42 U.S.C. §§ 7413, 7477 and 7545, and 28 U.S.C. § 1355. This Court has jurisdiction of the subject matter herein and over the parties consenting hereto pursuant to 28 U.S.C. § 1345 and pursuant to Sections 113, 167, and 211 of the CAA, 42 U.S.C. §§ 7413, 7545 and 7477.

2. Venue is proper under Section 113(b) of the Clean Air Act, 42 U.S.C. § 7413(b), and under 28 U.S.C. § 1391(b) and (c).

3. Notice of the commencement of this action has been given to the States of Colorado, Louisiana, New Jersey, Oklahoma and Texas, the California Air Resources Board, the Bay Area Air Quality Management District ("BAAQMD") and the South Coast Air Quality Management District ("SCAQMD") in accordance with Section 113(a)(1) of the Clean Air Act, 42 U.S.C. § 7413(a)(1), and as required by Section 113(b) of the Clean Air Act, 42 U.S.C. § 7413(b).

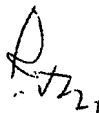

II. APPLICABILITY

4. The provisions of this Consent Decree shall apply to and be binding upon the United States, the Louisiana Department of Environmental Quality ("LDEQ"), the New Jersey Department of Environmental Protection ("NJDEP"), the Texas Commission on Environmental Quality ("TCEQ"), the Colorado Department of Public Health and Environment ("CDPHE"), the Oklahoma Department of Environmental Quality ("ODEQ") and upon Valero and Tesoro, as well as Valero's and Tesoro's respective successors and assigns, and shall apply to Tesoro's Golden Eagle Refinery and to each of Valero's Refineries identified herein until the Consent Decree is terminated with respect to such refinery pursuant to Part XXV (Termination); provided however that, with respect to any obligation applicable to an individual Valero Refinery pursuant to Parts IV through XXIV, inclusive, hereof, such obligation shall apply only to the specific Valero corporate entity that owns such Refinery.

5. In the event that Valero or Tesoro proposes to sell or transfer any of its refineries subject to this Consent Decree, then Valero or Tesoro, as applicable, shall advise in writing to such proposed purchaser or successor-in-interest of the existence of this Consent Decree and provide a copy of the Consent Decree, and shall send a copy of such written notification by certified mail, return receipt requested, to EPA before such sale or transfer, if possible, but no later than the closing date of such sale or transfer. This provision does not relieve Valero or Tesoro from having to comply with any applicable state or local regulatory requirement regarding notice and transfer of facility permits.

III. FACTUAL BACKGROUND

6. Valero operates thirteen (13) petroleum refineries in the United States for the manufacture of various petroleum-based products, including gasoline, diesel, and jet fuels, and other marketable petroleum by-products.

7. As more specifically described in Appendix A, Valero's petroleum refineries subject to this Consent Decree are located at: Ardmore, Oklahoma; Benicia, California; Corpus Christi (East), Texas; Corpus Christi (West), Texas; Denver, Colorado; Houston, Texas; Krotz Springs, Louisiana; Sunray (McKee), Texas; Paulsboro, New Jersey; St. Charles Parish, Louisiana; Texas City, Texas; Three Rivers, Texas; and Wilmington, California (hereinafter collectively, "Valero's Refineries").

8. Tesoro operates the Golden Eagle Refinery in Martinez, California for the manufacture of various petroleum-based products, including gasoline, diesel, and jet fuels, and other marketable petroleum by-products.

9. Petroleum refining involves the physical, thermal and chemical separation of crude oil into marketable petroleum products.

to. The petroleum refining process at Valero's Refineries and Tesoro's Golden Eagle Refinery results in emissions of criteria air pollutants, including nitrogen oxides ("NOx"), carbon monoxide ("CO"), particulate matter ("PM"), sulfur dioxide ("SO₂"), as well as volatile organic compounds ("VOCs") and hazardous air pollutants ("HAPs"), including benzene. The primary sources of these emissions are the fluid catalytic cracking units ("FCCUs"), process heaters and boilers, the sulfur recovery plants, wastewater treatment systems, fugitive emissions, and flares.

11. New Jersey and Valero Refining Company - New Jersey entered into an Administrative Consent Order ("ACO") settling various violations alleged by New Jersey of Valero's air pollution permit ("Title V Permit") issued by the New Jersey Department of Environmental Protection ("NJDEP") under Title V of the Clean Air Act, 42 USC 7661, and the New Jersey Air Pollution Control Act, N.J.S.A. 26:2C-1 et seq.

IV. NO_x Emissions Reductions from Heaters and Boilers

Program Summary: Valero will implement a program to reduce NO_x emissions from refinery heaters and boilers greater than 40 MMBTU/hr (HHV) by committing to an interim system-wide weighted average concentration emission limit for NO_x of 0.060 lbs./MMBTU, to be achieved by December 31, 2009, and a final system-wide weighted average concentration emission limit for NO_x of 0.044 lbs./MMBTU, to be achieved by December 31, 2011. Tesoro will reduce NO_x emissions from refinery heaters and boilers greater than 40 MMBTU/hr (HHV) at the Golden Eagle Refinery.

12. Valero shall implement at the Valero Refineries, and Tesoro shall implement at the Golden Eagle Refinery, various NO_x emission reduction measures and techniques to achieve system-wide and Golden Eagle Refinery-wide, respectively, NO_x emission levels for certain identified heaters and boilers at Valero's Refineries and the Golden Eagle Refinery. For purposes of this Consent Decree, "heaters and boilers" shall be defined to include any stationary combustion unit used for the purpose of burning fossil fuel for the purpose of (i) producing power, steam or heat by heat transfer or (ii) heating a material for initiating or promoting a process or chemical reaction in which the material participates as a reactant or catalyst, but expressly excluding any turbine, internal combustion engine, duct burner, CO boiler, incinerator or incinerator waste heat boiler.

A. Initial Inventory, Annual Update, and Compliance Plan for Valero Refineries

13. Appendix B to this Consent Decree (the "Initial Inventory") provides an initial list of all heaters and boilers for Valero's Refineries for which heat input capacity is greater than 40 MMBTU/hr (HHV). For purposes of this Consent Decree, "Covered Heaters and Boilers" shall include all heaters and boilers with heat input capacity greater than 40 MMBTU/hr (HHV) regardless of any applicable firing rate permit limitations.

14. The Initial Inventory identifies previously constructed heaters and boilers at the Valero Refineries that comprise the initial list of Covered Heaters and Boilers. The Initial Inventory also provides the following information concerning the Covered Heaters and Boilers:

- (a) Valero's designations for each of the Covered Heaters and Boilers;
- (b.) Identification of heat input capacity, and the source of such identification, for each of the Covered Heaters and Boilers. For purposes of this subparagraph, heat input capacity for each Covered Heater or Boiler shall equal the lesser of any applicable permit limit or Valero's best then-current estimate of its maximum heat input capacity (hereinafter, "Heat Input Capacity");
- (c) Identification of all applicable NO_x emission limitations, in pounds per million BTU, for each of the Covered Heaters and Boilers. For purposes of this part, the applicable NO_x emissions limitation for each of the Covered Heaters and Boilers at the Benicia Refinery shall be deemed 0.0331 lbs./MMBTU, as more fully described below; and
- (d) Statement of whether a continuous emission monitoring system ("CEMS") for NO_x has been installed on the respective Covered Heater or Boiler.

15. Valero shall submit to EPA an annual update to the Initial Inventory on or before March 31 each calendar year from 2006 through 2011, inclusive (the "Annual Update Report"), provided, however, that Valero shall not be obligated to submit any Annual Update Report after satisfying the provisions of Paragraphs 21 and 27. Valero shall designate the final Annual Update Report. The Annual Update Report shall revise any information included in the Initial Inventory or most recent Annual Update Report to the extent appropriate based upon the construction of a Covered Heater or Boiler or any change during the prior year to any of the previously existing Covered Heaters and Boilers, including the date of installation of any CEMS installed during the prior year. The Annual Update Report shall also include for each Covered Heater and Boiler the estimated actual emission rate in pounds of NO_x per MMBTU heat input (HHV) and tons per year and the type of data used to derive the emission estimate (i.e., emission factor, stack test, or CEM data).

B. Interim Emission Reductions and Timeframes for Valero Refineries

16. On or before December 31, 2006, Valero shall submit to EPA a compliance plan for attainment, by December 31, 2009, of a system-wide weighted average, as determined in accordance with Paragraph 28, for Covered Heaters and Boilers of 0.060 lbs.-NO_x/MMBTU (the "Interim Compliance Plan"). The Interim Compliance Plan is intended to reflect Valero's then-current strategy for satisfying the requirements of Paragraph 17. Valero shall not be bound by the terms of the Interim Compliance Plan.

17. By no later than December 31, 2009, Valero shall install NO_x control technologies on, or otherwise limit NO_x emissions from, certain Covered Heaters and Boilers such that the

system-wide weighted average, as determined in accordance with Paragraph 28, for NO_x emissions from the Covered Heaters and Boilers is no greater than 0.060 lbs.-NO_x/MMBTU.

18. Valero shall select from among the Covered Heaters and Boilers those units for which NO_x emissions shall be controlled or otherwise reduced so as to satisfy the requirements of Paragraph 17.

19. For the purposes of Paragraph 17 and in the event that Valero permanently ceases operation of any Covered Heaters or Boilers on or before December 31, 2009, then Valero may include each such shutdown unit in its demonstration of compliance with Paragraph 17 if Valero notifies the appropriate permitting authority that such unit is no longer operational and requests the withdrawal or invalidation of any permit or permit provisions authorizing operation of such unit. For purposes of Valero's demonstration under Paragraph 28 of compliance with Paragraph 17, the emissions of any such shutdown unit shall be equal to 0.000 lbs/MMBTU NO_x, and the heat input attributed to any shutdown Covered Heater or Boiler shall be its Heat Input Capacity prior to shutdown.

C. Final Emission Reductions and Deadlines for Valero Refineries

20. On or before December 31, 2008, Valero shall submit to EPA a compliance plan for attainment by December 31, 2011, of a system-wide weighted average for Covered Heaters and Boilers of 0.044 lbs.-NO_x/MMBTU (the "Compliance Plan"), as determined in accordance with Paragraph 28. The Compliance Plan is intended to reflect Valero's then-current strategy for satisfying the requirements of Paragraph 21. Valero shall not be bound by the terms of the Compliance Plan.

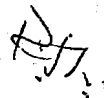

21. By no later than December 31, 2011, Valero shall install NO_x control technology on, or otherwise limit NO_x emissions from, certain Covered Heaters and Boilers such that the system-wide weighted average, as determined in accordance with Paragraph 28, for NO_x emission from the Covered Heaters and Boilers is no greater than 0.044 lbs.-NO_x/MMBTU.

22. Valero shall select from among the Covered Heaters and Boilers those units for which NO_x emissions shall be controlled or otherwise reduced so as to satisfy the requirements of Paragraph 21.

23. For the purposes of Paragraph 21 in the event that, on or before December 31, 2011, Valero permanently ceases operation of any Covered Heaters or Boilers, then Valero may include each such shutdown unit in its demonstration of compliance with Paragraph 21 if Valero notifies the appropriate permitting authority that such unit is no longer operational and requests the withdrawal or invalidation of any permit or permit provisions authorizing operation of such unit. For purposes of Valero's demonstration under Paragraph 28 of compliance with Paragraph 21, the emissions of any such shutdown unit shall be equal to 0.000 lbs/MMBTU NO_x, and the heat input attributed to any shutdown Covered Heater or Boiler shall be its Heat Input Capacity prior to shutdown.

D. Benicia Refinery

24. Valero shall satisfy Sections 9-10-301 and 9-10-403 of BAAQMD Regulation IX, Rule 10, as such provisions both relate to Covered Heaters and Boilers at the Benicia Refinery and establish NO_x emission standards for certain units, including the Covered Heaters and Boilers at the Benicia Refinery, based upon an emission level of 0.033 lbs.-NO_x/MMBTU. Compliance with these requirements shall be determined in accordance with BAAQMD's rules

and regulations, including without limitation the interchangeable emission reduction credit ("IERC") provisions of BAAQMD Regulation II, Rule 9. Nothing in this Consent Decree is intended or shall be construed to limit the methods available to Valero under the BAAQMD rules and regulations for compliance with Sections 9-10-301 and 9-10-403 thereof; provided however, no credits generated under the BAAQMD rules and regulations may be traded or sold to another facility, as is expressly proscribed by Paragraph 296(d).

25. For the purpose of demonstrating compliance under Paragraph 28 with Paragraphs 17 and 21, each of the Covered Heaters and Boilers at the Benicia Refinery shall be deemed to emit 0.033 lbs.-NO_x IMBTU (as 12-month averages). This paragraph imposes no independent permitting requirements upon the Benicia Refinery.

26. In the event that EPA, the BAAQMD, the BAAQMD Hearing Board, or a court of competent jurisdiction should finally determine that the Consent Decree prohibits or limits the ability of Valero to generate, bank or use JERCs, as defined in BAAQMD Regulation II, Rule 9, from emission reductions at any emission unit at the Benicia Refinery, including without limitation the Covered Heaters and Boilers at Benicia, then Valero may elect, upon written notice to EPA, to render null and void the provisions of this Part IV of the Consent Decree only with respect to the Benicia Refinery. In the event that Valero provides written notice to EPA of such election pursuant to this paragraph, the release from liability under Part XXV (Effect of Settlement) of this Consent Decree applicable to NO_x emissions from Covered Heaters and Boilers at the Benicia Refinery shall be rendered null and void. In lieu of providing such notice to EPA Valero may propose and EPA may agree to allow Valero to implement such actions sufficient to satisfy the obligations of Paragraphs 17 and 21 as if Paragraphs 17 and 21 had

remained in full force and effect notwithstanding an adverse determination by EPA, the BAAQMD, the BAAQMD Hearing board or a court of competent jurisdiction with respect to the Benicia Refinery. If such an agreement is reached, committed to writing and signed by Valero and EPA, then the release from liability under Part XXIV of this Consent Decree applicable to NO_x emissions from Covered Heaters and Boilers at the Benicia Refinery shall not be rendered void under this paragraph.

E.. **Compliance Demonstration**

27. By no later than March 31, 2010, Valero shall submit to EPA a report demonstrating compliance with Paragraph 17. By no later than March 31, 2012, Valero shall submit to EPA a report demonstrating compliance with Paragraph 21. The compliance reports submitted pursuant to this paragraph shall include the following information for relevant refineries, as applicable to Valero's interim or final compliance demonstration:

(a.) The NO_x emission limit for each Covered Heater or Boiler which is the least of the following: (i) the NO_x emission limit, in pounds per MMBTU at HHV (as a 365-day rolling average if based on CEMS, or as a 3-hour average if based on stack tests) based upon any existing federally enforceable, non-Title V (permanent) permit condition, including such a condition as may be reflected in a consolidated permit (where applicable), of the Covered Heater or Boiler, or (ii) the NO_x emission limit, in pounds per MMBTU at HHV, reflected in any permit application for a federally enforceable, non-Title V (permanent) permit, including a consolidated permit where such limit would also be permanent, submitted by Valero for such Covered Heater or Boiler prior to the date of submittal of the Compliance Report (each Covered Heater and Boiler at the Benicia Refinery is deemed to have a NO_x emission limit of 0.033 lbs./MMBTU).

In the event that Valero identifies a NO_x emission limit, in pounds per MMBTU at HHV, for a Covered Heater or Boiler pursuant to this paragraph based on a NO_x emission limit then reflected in a pending permit application, Valero shall not withdraw such application nor may Valero seek to modify that application to increase the NO_x emission limit reflected in such application without prior EPA approval.

(b.) Heat Input Capacity, in MMBTU/hr at HHV, for each Covered Heater and Boiler, including an explanation of any change relative to that reported in the most recent Annual Update.

(c.) A demonstration of compliance with Paragraph 17 or 21, as applicable, performed in accordance with Paragraph 28.

28. Valero shall demonstrate compliance with the provisions of Paragraph 17 by the following inequality: $0.060 \geq \frac{\sum_i^n (EL_i \times HIR_i)}{\sum_i^n HIR_i}$

Valero shall demonstrate compliance with the provisions of Paragraph 21 by the following

inequality: $0.044 \geq \frac{\sum_i^n (EL_i \times HIR_i)}{\sum_i^n HIR_i}$

For purposes of this Paragraph 28:

EL_i = The relevant NO_x Emission Limit for Covered Heater or Boiler "i", in pounds per million BTU (HHV), as reported pursuant to Paragraph 27(a);

HIR_i = Heat Input Capacity of Covered Heater or Boiler "i", in million BTU (HHV) per hour, as reported pursuant to Paragraph 27(b);

n = The total number of Covered Heaters and Boilers at all of Valero's Refineries subject to this Consent Decree.

For purposes of the compliance demonstration evaluated by the foregoing inequalities, the NO_x emission limitation (EL_i) for each Covered Heater and Boiler at the Benicia Refinery shall be deemed to be 0.033 lbs./MMBTU, pursuant to Paragraph 25.

F. Monitoring Requirements

29. By no later than December 31, 2011, for Covered Heaters and Boilers existing on the Date of Lodging for which Valero takes an emission limit of <0.060 lbs/MMBTU without adding additional controls to meet the requirement of Paragraphs 17 and 21; and beginning no later than 180 days after installing controls on a Covered Heater and Boiler for purposes of compliance with the requirement of Paragraphs 17 and 21, Valero shall monitor each such Covered Heater or Boiler as follows:

(a) For a Covered Heater or Boiler with a Heat Input Capacity of 150 MMBTU/hr (HHV) or greater, Valero shall install or continue to operate a continuous emission monitoring system ("CEMS") for NO_x;

(b) For a Covered Heater or Boiler with a Heat Input Capacity greater than 100 MMBTU/hr (HHV) but less than or equal to 150 MMBTU/hr (HHV), Valero shall install or continue to operate a CEMS for NO_x, or monitor NO_x emissions with a predictive emissions monitoring system ("PEMS") developed and operated pursuant to the requirements of Appendix S of this Consent Decree;

(c) For a Covered Heater or Boiler with a Heat Input Capacity of less than or equal to 100 MMBTU/hr (HHV), Valero shall conduct an initial performance test and any periodic tests that may be required by EPA or by the applicable State or local permitting authority under the applicable regulatory authority. Valero shall report the results of the initial performance testing

to EPA and the appropriate Plaintiff-Intervener. Valero shall use Method 7E or an EPA-approved alternative test method to conduct initial performance testing for NO_x emissions required by this subparagraph (c).

Nothing in this Consent Decree shall preclude a facility from converting a 3-hour rolling average limit to the same limit expressed as a 365-day rolling average limit if such demonstration of compliance is based upon CEMS or PEMS.

30. Valero shall install, certify, calibrate, maintain and operate all NO_x CEMS required by Paragraph 29 in accordance with the provisions of 40 C.F.R. Section 60.13 that are applicable to CEMS (excluding those provisions applicable only to continuous opacity monitoring systems) and Part 60, Appendices A and F, and the applicable performance specification of 40 C.F.R. Part 60, Appendix B. With respect to 40 C.F.R. Part 60, Appendix F, in lieu of the requirements of 40 C.F.R. Part 60, Appendix F §§ 5.1.1, 5.1.3 and 5.1.4., Valero must conduct either a Relative Accuracy Audit ("RAA") or a Relative Accuracy Test Audit ("RATA") on each CEMS required by Paragraph 29 at least once every three (3) years. Valero must also conduct Cylinder Gas Audits ("CGA") each calendar quarter during which a RAA or a RATA is not performed. With respect to the Benicia Refinery, Valero may conduct a Field Accuracy Test ("FAT") as defined in BAAQMD regulations or procedures in lieu of the required RAA or CGA.

G. Golden Eagle Refinery

31. Tesoro shall satisfy Sections 9-10-301 and 9-10-403 of BAAQMD Regulation IX, Rule 10, as such provisions both relate to Covered Heaters and Boilers at the Golden Eagle Refinery and establish NO_x emission standards for certain units, including the Covered Heaters

and Boilers at the Golden Eagle Refinery, based upon an emission level of 0.033 lbs.-NO_x/MMBTU. Compliance with these requirements shall be determined in accordance with BAAQMD's rules and regulations, including without limitation the interchangeable emission reduction credit ("IERC") provisions of BAAQMD Regulation II, Rule 9. Nothing in this Consent Decree is intended or shall be construed to limit the methods available to Tesoro under the BAAQMD rules and regulations for compliance with Sections 9-10-301 and 9-10-403 thereof; provided however, no credits generated under the BAAQMD rules and regulations may be traded or sold to another facility as provided in Paragraph 296(d).

32. In the event that EPA, the BAAQMD, the BAAQMD Hearing Board, or a court of competent jurisdiction should finally determine that the Consent Decree prohibits or limits the ability of Tesoro to generate, bank or use IERCs, as defined in BAAQMD Regulation II, Rule 9, from emission reductions at any emission unit at the Golden Eagle Refinery, including without limitation the Covered Heaters and Boilers at the Golden Eagle Refinery, then Tesoro may elect, upon written notice to EPA, to render null and void the provisions of this Part IV of the Consent Decree only with respect to the Golden Eagle Refinery. In the event that Tesoro provides written notice to EPA of such election pursuant to this paragraph, the release from liability under Part XXIV (Effect of Settlement) of this Consent Decree applicable to NO_x emissions from Covered Heaters and Boilers at the Golden Eagle Refinery shall be rendered null and void. In lieu of providing such notice to EPA, Tesoro may propose and EPA may agree to allow Tesoro to implement such actions sufficient to satisfy the obligations of Paragraphs 17 and 21 as if Paragraphs 17 and 21 had remained in full force and effect notwithstanding an adverse determination by EPA, the BAAQMD, the BAAQMD Hearing board or a court of competent

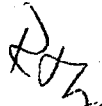

jurisdiction with respect to the Golden Eagle Refinery. If such an agreement is reached, committed to writing and signed by Tesoro and EPA, then the release from liability under Part XXIV of this Consent Decree applicable to NO_x emissions from Covered Heaters and Boilers at the Golden Eagle Refinery shall not be rendered void under this paragraph.

33. Reserved.

H. Additional Provisions

34. Nothing in this Consent Decree is intended to limit Valero or Tesoro, as applicable, from satisfying any provisions of this Part IV earlier than the applicable compliance date specified in this part.

V. NO_x EMISSION REDUCTIONS FROM FCCUs

Program Summary: Valero will implement a program to limit NO_x emissions from its FCCD regenerators and CO boilers and from the Corpus Christi West HOC by achieving a system-wide average of unit-specific NO_x concentration emission limits for each of the FCCDs and the Corpus Christi West HOC subject to this Part V and by implementing certain emission control systems or otherwise satisfying NO_x emission standards at the Houston, Paulsboro, St. Charles, Texas City and Wilmington Refineries, all of which are located in or near areas designated as in nonattainment with the ozone NAAQS. Tesoro will implement emission control technologies or techniques to reduce NO_x emissions from the Golden Eagle Refinery to 20 ppm, measured as a 365-day rolling average.

A. Golden Eagle

35. By no later than September 30, 2006, Tesoro shall implement emission control technologies or techniques to reduce NO_x emissions from the Golden Eagle FCCD to concentration emission limits no greater than 20 ppmvd, measured as a 365-day rolling average, and 40 ppmvd, measured as a 7-day rolling average, both at 0% O₂, as determined prior to commingling with other streams.

36. By no later than September 30, 2006, Tesoro shall submit to the appropriate permitting authority an application to impose NO_x concentration emission limits upon the Golden Eagle FCCD of 20 ppm, measured as a 365-day rolling average, and 40 ppm, measured as a 7-day rolling average, both at 0% oxygen, prior to commingling with other streams.

B. Houston and Texas City

37. By no later than December 31, 2007, Valero shall complete installation and thereafter begin operation of a LoTOx® system or alternative technology to reduce NO_x emissions from each FCCD at the Houston and Texas City Refineries. Valero shall thereafter comply with NO_x concentration emission limits for the respective refinery's FCCD of no greater than 20 ppmvd, measured as a 365-day rolling average, and 40 ppmvd, measured as a 7-day rolling average, both at 0% O₂.

C. Paulsboro

38. Valero shall continue to operate the existing oxygen control system ("O₂ es") at the FCCD at the Paulsboro Refinery. Within thirty (30) days after the turnaround for the FCCD at the Paulsboro refinery currently scheduled for 2006, Valero shall commence a new optimization study of the O₂ CS on the existing high efficiency regenerator at the Paulsboro refinery in an effort to achieve NO_x concentration emissions from the FCCD of 20 ppmvd (at 0% O₂) as a 365-day rolling average and 40 ppm as 7-day rolling average (at 0% O₂).

39. Within sixty (60) days after the conclusion of the optimization study but by no later than September 30, 2007, Valero shall submit to EPA and NJDEP a report detailing the NO_x concentration emissions achieved for the Paulsboro FCCD through optimization of the O₂ CS.

D. St. Charles

40. On or before December 31, 2005, Valero shall commence an optimization study of the O₂ CS on the existing high efficiency regenerator at the St. Charles refinery in an effort to achieve NO_x concentration emissions from the FCCD of 20 ppmvd (at 0% O₂) as a 365-day rolling average and 40 ppmvd (at 0% O₂) as 7-day rolling average.

41. Within sixty (60) days after the conclusion of the optimization study but by no later than September 30, 2006, Valero shall submit to EPA and LDEQ a report detailing the NO_x concentration emissions achieved for the St. Charles FCCU through optimization of the O₂ CS.

E. Wilmington

42. On or before December 31, 2005, Valero shall commence an optimization study of an O₂ CS on the existing high efficiency regenerator at its Wilmington refinery in an effort to achieve NO_x concentration emissions of 20 ppmvd (at 0% O₂) as a 365-day rolling average and 40 ppmvd (at 0% O₂) as 7-day rolling average.

43. Within sixty (60) days after the conclusion of the optimization period but by no later than September 30, 2006, Valero shall submit to EPA a report detailing the NO_x concentration emissions achieved for the Wilmington FCCU through optimization of the O₂ CS.

F. Additional Requirements at Paulsboro, St. Charles or Wilmington

44. By no later than December 31, 2010, Valero shall establish and comply with NO_x concentration emission limits no greater than 20 ppmvd, measured as a 365-day rolling average, and 40 ppmvd, measured as a 7-day rolling average, both at 0% oxygen, for at least one of the FCCD ultra-low NO_x regenerators located at either Valero's Paulsboro, St. Charles or Wilmington Refineries.

G. FCCU and Corpus Christi West HOC NO_x Emission Reductions

45. Valero shall attain a system-wide, coke burn-weighted average of NO_x concentration emission limits for each FCCU at Valero's Ardmore, Corpus Christi East, Denver, Houston, Krotz Springs, McKee, Paulsboro, St. Charles, Texas City, Three Rivers and Wilmington Refineries, the Corpus Christi West HOC (hereinafter collectively referred to as "Covered FCCDs") and the FCCU at the Golden Eagle Refinery in accordance with the provisions of this Section G.

46. Appendix C to this Consent Decree (the "Initial FCCD Annual Coke Burn Rates") provides a list of all Covered FCCDs and the Golden Eagle FCCU, as of the Date of Lodging. Appendix C also identifies Valero's best estimate of maximum coke burn rate and any permit limits applicable to maximum annual coke burn rate for each such FCCU and HOC, as of the Date of Lodging.

47. Valero shall submit to EPA an annual update to Appendix C on or before March 31 of each calendar year from 2007 through 2012, inclusive (the "Annual FCCU Update Report"), provided, however, that Valero shall not be obligated to submit any Annual Update Report after satisfying the provisions of Paragraphs 55 and 56. The Annual FCCU Update Report shall identify Valero's best estimate of maximum annual coke burn rate and any permit limits relating to maximum coke burn rate for each Covered FCCD as of the date of the report. Valero shall identify and explain any such differences from the previous report under Paragraph 46 and this Paragraph 47.

48. Valero shall attain the following system-wide, coke burn-weighted average of NO_x concentration emission limits for Covered FCCDs and the Golden Eagle Refinery FCCU by the

following dates: (a) an interim NO_x concentration emission limit average of 69.2 ppmvd (at 0% O₂), as a 365-day rolling average, by December 31, 2008 (the "Interim NO_x System-Wide Average") and (b) a final NO_x concentration emission limit average of 33.4 ppmvd (at 0% O₂), as a 365-day rolling average, by December 31, 2011 (the "NO_x System-Wide Average").

49. As a component of its compliance with Paragraph 48, Valero shall satisfy the FCCD regenerator-specific NO_x emission control requirements established pursuant to Part V, Sections A through F, inclusive. In addition to the refinery-specific NO_x emission control measures in accordance with Sections V.A. through V.F, inclusive, Valero shall select from among the Covered FCCUs those units for which NO_x emissions shall be controlled or otherwise reduced so that Valero satisfies the Interim NO_x System-Wide Average and the NO_x System-Wide Average. Provided however, no Covered FCCU will have a permit limit higher than 80 ppmvd at 0% O₂ on a 365-day rolling average at the time it demonstrates compliance with Paragraph 48(b).

50. For the purposes of Valero's satisfaction of Paragraph 48(a) and in the event that, subsequent to the Date of Entry of this Consent Decree and before December 31, 2008, Valero permanently ceases operation of any Covered FCCU at Valero's Refineries, then Valero may include each such shutdown unit in its demonstration of compliance with the Interim NO_x System-Wide Average, if Valero notifies the appropriate permitting authority that such unit is no longer operational and requests the withdrawal or invalidation of any permit or permit provisions authorizing operation of such unit. For purposes of Valero's demonstration under Paragraphs 53 and 54 of compliance with the Interim NO_x System-Wide Average, the emissions rate of any such shutdown unit shall be equal to 20 ppmvd NO_x at 0% O₂, and the maximum

coke burn rate attributed to any such shutdown FCCD or Corpus Christi West HOC shall equal the lesser of Valero's best estimate of maximum coke burn rate or the FCCU's permit limit relating to maximum coke burn rate prior to the FCCU shutdown, provided, however, that if a new FCCD is also constructed and operated at such refinery, then the maximum coke burn rate and the NO_x emission limit of such new FCCU shall be used in lieu of the original Covered FCCD.

51. For purposes of this Section V.G, "maximum coke burn rate" shall mean the lesser of the permitted coke burn rate, if any, or Valero's best current estimate on an average annual basis. In addition and solely for the Ardmore FCCU, its maximum coke burn rate will be the combined maximum coke burn rate for both of the regenerators.

52. For the purposes of Valero's satisfaction of Paragraph 48(b) and in the event that Valero permanently ceases operation of any Covered FCCD subsequent to the Date of Entry of this Consent Decree and before December 31, 2011, then Valero may include each such shutdown unit in its demonstration of compliance with the NO_x System-Wide Average, if Valero notifies the appropriate permitting authority that such unit is no longer operational and requests the withdrawal or invalidation of any permit or permit provisions authorizing operation of such unit. For purposes of Valero's demonstration under Paragraphs 55 and 56 of compliance with the NO_x System-Wide Average, the concentration emission limit of any such shutdown unit shall be equal to 20 ppmvd NO_x at 0% O₂, and the maximum coke burn rate attributed to any such Covered FCCU that is shutdown shall equal the lesser of Valero's best estimate of maximum coke burn rate or the FCCU's permit limit relating to maximum coke burn rate prior to the FCCU shutdown, provided, however, that if a new FCCD is also constructed and operated at

such refinery, then the maximum coke burn rate and the NOx emission limit of such new FCCD shall be used in lieu of the original Covered FCCD.

53. Compliance Demonstration: By March 31, 2009, Valero shall submit to EPA a report demonstrating compliance with the Interim NOx System-Wide Average. The compliance report submitted pursuant to this paragraph shall include the following information for the relevant refineries, as applicable to Valero's compliance demonstration:

(a.) The NOx concentration emission limit for each Covered FCCD and the Golden Eagle Refinery FCCD which is the least of the following: (i) the allowable NOx concentration emission limit (as a 365-day average), based upon any existing, federally enforceable non-Title V permit condition, including such a condition as may be reflected in a consolidated permit (where applicable), or (ii) the NOx concentration emission limit reflected in any application for a federally enforceable non-Title V permit, including a consolidated permit where such limit would also be permanent, submitted by Valero for such Covered FCCD prior to the date of submittal of the compliance report. In the event that Valero and Tesoro, as applicable, identifies a NOx concentration emission limit for a Covered FCCD pursuant to this paragraph based on a NOx concentration emission limit then reflected in a pending permit application, Valero shall not withdraw such application nor may Valero seek to modify that application to, nor request an increase in the NOx concentration emission limit reflected in such application, without prior EPA approval. For purposes of the demonstration in subparagraph (c), the NOx concentration emission limit for the two Ardmore FCCD regenerators shall be deemed to be the NOx concentration emission limit taken on the combined stack. For purposes of this paragraph, the

NOx concentration emission limit attributed to the Golden Eagle FCCD shall be 20 ppmvd upon Tesoro's satisfaction of Paragraph 36.

(b.) Reserved.

(c.) A demonstration of compliance with the Interim NOx System-Wide Average performed in accordance with Paragraph 54.

54. Valero shall demonstrate compliance with the Interim NOx System-Wide Average

by meeting the following inequality: $69.2 \geq \frac{\sum^n (ELR_j \times HIR_j)}{\sum^n HIR_j}$

Where:

ELR_j = The relevant NOx concentration emission limit for the Covered FCCD and the Golden Eagle FCCD "i", in parts per million, as reported pursuant to Paragraph 53(a);

HIR_j = Maximum coke burn rate of the Covered FCCD and the Golden Eagle FCCD "i", as reported pursuant to Paragraph 47;

n = The total number of Covered FCCDs plus the Golden Eagle Refinery FCCD.

55. Compliance Demonstration: By March 31, 2012, Valero shall submit to EPA a report demonstrating compliance with the NOx System-Wide Average. The compliance report submitted pursuant to this paragraph shall include the following information for the relevant refineries, as applicable to Valero's compliance demonstration:

(a.) The NOx emission limit for each Covered FCCD and the Golden Eagle Refinery FCCD which is the least of the following: (i) the allowable NOx concentration emission limit (as a 365-day average), based upon any existing, federally enforceable non-Title V permit condition, including such a condition as may be reflected in a consolidated permit (where applicable), or (ii) the NOx concentration emission limit reflected in any application for a federally enforceable

non-Title V permit, including a consolidated permit where such limit would also be permanent, submitted by Valero for such Covered FCCD prior to the date of submittal of the compliance report. In the event that Valero and Tesoro, as applicable, identifies a NOx concentration emission limit for a Covered FCCD pursuant to this paragraph based on a NOx concentration emission limit then reflected in a pending permit application, Valero shall not withdraw such application nor may Valero seek to modify that application to, nor request an increase in the NOx concentration emission limit reflected in such application without prior EPA approval. For purposes of the demonstration in subparagraph (c), the NOx concentration emission limit for the two Ardmore FCCU regenerators shall be deemed to be the NOx concentration emission limit taken on the combined stack. For purposes of this paragraph, NOx concentration emission limit attributed to the Golden Eagle FCCD shall be 20 ppmvd upon Tesoro's satisfaction of Paragraph 36.

(b.) Reserved.

(c.) A demonstration of compliance with the NOx System-Wide Average performed in accordance with Paragraph 56.

56. Valero shall demonstrate compliance with the NOx System-Wide Average by

meeting the following inequality: $33.4 \geq \sum_{j=1}^n (ELR_j \times HIR_j) / \sum_{j=1}^n HIR_j$

Where:

ELR_j = The relevant NOx concentration emission limit for the Covered FCCD and the Golden Eagle FCCU "i", in parts per million, as reported pursuant to Paragraph 55(a);

HIR_j = Maximum coke burn rate of the Covered FCCD and the Golden Eagle FCCD "i", as reported pursuant to Paragraph 47;

n = The total number of Covered FCCDs plus the Golden Eagle Refinery FCCD.

57. Reserved.

58. In the event that EPA, the SCAQMD, the SCAQMD Hearing Board or a court of competent jurisdiction should finally determine that the Consent Decree prohibits or limits the ability of Valero to generate, bank or use RTC's, as defined in SCAQMD Rule 2007, from emission reductions at the Wilmington FCCD, then Valero may elect, upon written notice to EPA, to render null and void the provisions of Part V of this Consent Decree, as such provisions relate to the Wilmington FCCD. In the event that Valero provides written notice to EPA of such election pursuant to this paragraph, then the release from liability under Part XXIV applicable to Nonattainment NSR requirements relating to NO_x emissions from the FCCD at the Wilmington Refinery shall be null and void. In lieu of providing such notice to EPA, Valero may propose and EPA may agree to allow Valero to implement such actions sufficient to satisfy the obligations of Part V.G of this Consent Decree as if Part Y.G had remained in full force and effect notwithstanding an adverse determination by EPA, the SCAQMD, the SCAQMD Hearing board or a court of competent jurisdiction with respect to the Wilmington Refinery. If such an agreement is reached, committed to writing and signed by Valero and EPA, then the release from liability under Part XXIV of this Consent Decree applicable to NO_x emissions from the Wilmington FCCD shall not be rendered void under this paragraph.

H. Additional Provisions

59. Notwithstanding any provision of this Consent Decree to the contrary and in lieu of complying with any NO_x emission control requirements established pursuant to this Part V, Valero may elect to achieve NO_x concentration emission limits of 20 ppmvd (at 0% O₂) or less

as a 365-day rolling average and 40 ppmvd (at 0% O₂) or less as a 7-day rolling average by permanently shutting down such FCCD, FCCD-regenerator or the Corpus Christi West HOC, or by application of any emission reduction method or technology, including any technology not specified in this Consent Decree, by the refinery-specific compliance date specified in this Part V. Valero's election to satisfy its obligations under this Part V through compliance with this paragraph shall not limit the applicability or extent of Part XXIV (Effect of Settlement) with respect to Covered FCCU.

60. Valero shall take such action as may be necessary to ensure that each 365-day rolling average NO_x emission limit used to demonstrate compliance under Paragraphs 55 and 56 is less than or equal to 80 ppm. In addition and as part of each permit or permit application under Paragraphs 55 and 56, Valero shall also have or have applied for a 7-day rolling average NO_x concentration emission limit that shall be numerically twice the 365-day rolling average NO_x concentration emission limit used for that FCCU to demonstrate compliance under Paragraphs 55 and 56.

I. CEMS

61. Beginning no later than the date set forth below each Covered FCCU and the Golden Eagle FCCU, Valero or Tesoro, as applicable, shall use NO_x and O₂ CEMS to monitor performance of the FCCU and to report compliance with the terms and conditions of this Consent Decree:

(a.) Ardmore - Next scheduled Turnaround (currently anticipated to occur in 2005), or such later date as determined or approved by the ODEQ in accordance with the



provisions of the Administrative Consent Order, dated March 7, 2002, between Valero and

ODEQ

- (b.) Corpus Christi East - Upon Date of Entry
- (c.) Corpus Christi West -- 180 days from Date of Entry
- (d.) Denver - June 30, 2006
- (e.) Houston -- Next scheduled Turnaround (currently anticipated to occur in 2006)
- (f.) Krotz Springs -- Within 1 year of Date of Entry
- (g.) McKee -- Within 1 year of Date of Entry
- (h.) Paulsboro -- Next scheduled Turnaround (currently anticipated to occur in 2006)
- (i.) St. Charles - Upon Date of Entry
- (j.) Texas City-- Upon Date of Entry
- (k.) Three Rivers -- December 31, 2005
- (l.) • Wilmington -- Upon Date of Entry
- (m.) Golden Eagle -- September 30, 2006

62. The CEMS will be used to demonstrate compliance with the respective NOx concentration emission limits established pursuant to this Part V. Valero and Tesoro shall make CEMS data available to EPA and any appropriate Plaintiff-Intervener upon demand as soon as practicable. Valero or Tesoro, as relevant, shall install, certify, calibrate, maintain and operate all CEMS required by this paragraph in accordance with the provisions of 40 C.F.R. § 60.13 that are applicable to CEMS (excluding those provisions applicable only to continuous opacity

monitoring systems) and Part 60, Appendices A and F, and the applicable performance specification test of 40 e.F.R. Part 60, Appendix B. With respect to 40 C.F.R. Part 60 Appendix F, in lieu of the requirements of 40 C.F.R. Part 60, Appendix F §§ 5.1.1, 5.1.3 and 5.1.4, Valero or Tesoro, as applicable, must conduct either a RAA or a RATA on each CEMS at least once every three (3) years. Valero or Tesoro, as applicable, must also conduct eGA each calendar quarter during which a RAA or a RATA is not performed. With respect to the Golden Eagle Refinery, Tesoro may conduct a FAT, as defined in BAAQMD regulations or procedures, in lieu of the required RAA or CGA.

63. Reserved.

VI. SO₂ Emission Reductions from FCCUs and McKee Sulfuric Acid Plant

Program Summary: Valero and Tesoro shall implement a program to reduce SO₂ emissions from their FCCDs, which shall include the installation of wet gas scrubber ("WGS") technology systems on selected FCCUs and otherwise limiting SO₂ emissions from other FCCDs, including, in certain cases, through the use of SO₂-reducing catalyst additives and/or hydrotreating. Valero shall also install a scrubber to reduce SO₂ emissions from the McKee Refinery Sulfuric Acid Plant.

A. Ardmore

64. By no later than the next scheduled turnaround (currently anticipated to occur in 2005), or such later date as determined or approved by the ODEQ in accordance with the provisions of the Administrative Consent Order, dated March 7, 2002, between Valero and ODEQ, Valero shall complete installation and thereafter begin operation of a WGS to control emissions from both Ardmore FCCU Regenerator 1 and Ardmore FCCU Regenerator 2 at the Ardmore FCCD. Valero shall then comply with an SO₂ concentration emission limit, at the point of emission to the atmosphere, of no greater than 25 ppmvd, measured as a 365-day rolling average, and 50 ppmvd, measured as a 7-day rolling average, both at 0% O₂.

B. Benicia

65. Valero shall continue use of hydrotreating on the FeCU at the Benicia Refinery in accordance with current practices and applicable permits,

66. Valero shall commence implementation of the 80₂ adsorbing catalyst additive protocol described in Appendix E under the schedule identified in Appendix E to this Consent Decree at the FeCD at the Benicia Refinery.

67. By no later than the turnaround currently scheduled for the Benicia Fluid Coker during 2011, Valero shall complete installation and, within one hundred eighty (180) days thereafter, begin operation of a regenerative scrubber to control 80₂ emissions from the Benicia Fluid Coker. Valero shall design and operate the regenerative scrubber and comply with emission limits of no greater than 25 ppmvd, measured as a 365-day rolling average and 50 ppmvd, measured as a 7-day rolling average, both at 0% O₂ or, in the alternative, Valero shall construct and operate such a scrubber and comply with concentration-based emission limits based upon at least a 95% reduction in 80₂ emissions attributable to the Benicia Fluid Coker, such emission limits are to be established by EPA after Valero conducts an optimization study and demonstration program under Paragraph 88. Notwithstanding the foregoing, if Valero demonstrates to EPA's satisfaction that the total installed cost for such a regenerative scrubber is more than 105% of the current (at the time of design) total installed cost for a regenerative scrubber designed to achieve a 93% reduction in 80₂ emissions attributable to the Benicia Fluid Coker and upon EPA approval of such design, in consideration of Appendix L and Valero's making incremental design improvements that result in maximum 80₂ control and a total installed cost of no more than 105% of the total installed cost for a regenerative scrubber

designed to achieve a 93% reduction in S02 emission, Valero shall construct and operate such scrubber and comply with concentration emission limits based upon at least a 93% reduction in S02 emissions attributable to the Benicia Fluid Coker, such emission limits are to be established by EPA after Valero conducts an optimization study and demonstration program under Paragraph 88. If Valero determines that the regenerative scrubber is not viable, Valero shall instead install a conventional **WAS** to reduce S02 emissions from the Benicia Fluid Coker; provided however that the conventional **WAS** must be designed and operated and shall then comply with an S02 emission limit attributable to the Benicia Fluid Coker of no greater than 25 ppmvd, measured as a 365-day rolling average and 50 ppmvd, measured as a 7-day rolling average, both at 0% O₂.

68. Reserved.

C. Corpus Christi East, Denver and Wilmington

69. Valero shall commence implementation of the S02 absorbing catalyst additive protocol described in Appendix E under the schedule identified in Appendix E to this Consent Decree at each of the following refineries: Corpus Christi East, Denver, and Wilmington.

70. By no later than December 31, 2006, Valero shall notify EPA of Valero's selection of the refinery at which the **WAS** shall be installed pursuant to this Section VI.C (the "Selected Refinery"). Valero's election in this context shall be at its sole discretion. Upon such notification to EPA and in lieu of continuing thereafter to comply with the S02 absorbing catalyst additive protocol described in Appendix E, the Selected Refinery shall comply with Paragraph 71.

71. By no later than the turnaround for the Selected Refinery, currently anticipated to occur in 2010 at Corpus Christi East, Denver and Wilmington, Valero shall complete installation and thereafter begin operation of a WGS to control emissions from the FCCD or shut down the FCCD at the Selected Refinery. Valero shall design and operate the WGS to achieve and shall then comply with SO₂ concentration emission limits at the point of emission to the atmosphere of no greater than 25 ppmvd, measured as a 365-day rolling average basis, and 50 ppmvd, measured as a 7-day rolling average basis, both at 0% O₂.

72. In lieu of continuing to comply with the provisions of Paragraph 69 at the Corpus Christi East, Denver and/or Wilmington Refineries, Valero may elect to limit SO₂ concentrations in emissions from the FCCU at a non-Selected Refinery to 25 ppmvd or less, measured as a 365-day rolling average, and 50 ppmvd or less, measured as a 7-day rolling average, both at 0% O₂, by permanently shutting down such FCCD or by application of any emission reduction method or technology. Valero shall provide notice to EPA of such election which shall be effective by no later than the date of completion for the demonstration period pursuant to Appendix E.

D. Corpus Christi West

73. By no later than sixty (60) days from the Date of Lodging of this Consent Decree, Valero shall comply with SO₂ concentration emission limits at the point of emission to the atmosphere of no greater than 25 ppmvd measured as a 365-day rolling average and 50 ppmvd measured as a 7-day rolling average, both at 0% O₂.

E. Three Rivers

74. By no later than December 31, 2006, Valero shall complete installation and begin operation of a WGS to control emissions from the Three Rivers FCCU. Valero shall then

comply with SO₂ concentration emission limits at the point of emission to the atmosphere of no greater than 25 ppmvd measured as a 365-day rolling average and 50 ppmvd measured as a 7-day rolling average, both at 0% O₂.

F. Houston

75. By no later than March 31, 2007, Valero shall complete installation and thereafter begin operation of a WGS to control emissions from the FCCD at the Houston Refinery. Valero shall design and operate the WGS and comply with SO₂ concentration emission limits at the point of emission to the atmosphere of no greater than 25 ppmvd, measured as a 365-day rolling average basis, and 50 ppmvd, measured as a 7-day rolling average, both at 0% O₂ from the Houston FCCD.

G. Krotz Springs

76. By no later than December 31, 2006, Valero shall commence implementation of the SO₂ adsorbing catalyst additive protocol described in Appendix E under the schedule identified in Appendix E for the Krotz Springs FCCD.

H. McKee

77. By no later than June 30, 2006, Valero shall commence implementation of the SO₂ adsorbing catalyst additive protocol described in Appendix E under the schedule identified in Appendix E for the McKee FCCD.

78. By no later than December 31, 2007, Valero shall complete installation and begin operation of a Sulfuric Acid Plant Scrubber designed and operated to at least achieve a 90% reduction in SO₂ emissions from the McKee Sulfuric Acid Plant to achieve the NSPS standards of performance for SO₂ emissions for a sulfuric acid plant promulgated at 40 C.F.R. §

60.82. Upon completion of the installation and the startup of the Acid Plant Scrubber, the McKee Sulfuric Acid Plant shall be an affected facility under NSPS Subpart H.

I. Paulsboro

79. By the Date of Entry, Valero shall complete installation and begin operation of a WGS to control emissions from the Paulsboro FCCU. Valero shall design and operate the WGS and then comply with SO₂ concentration emission limits at the point of emission to the atmosphere of no greater than 25 ppmvd, measured as a 3M-day rolling average, and 50 ppmvd, measured as a 7-day rolling average, both at 0% O₂.

J. St. Charles

80. By no later than June 30, 2005, Valero shall operate its St. Charles FCCU so that it complies with SO₂ concentration emission limits of no greater than 25 ppmvd, measured as a 365-day rolling average, and 50 ppmvd, measured as a 7-day rolling average, both at 0% O₂.

K. Texas City

81. Upon the Date of Entry of this Consent Decree, Valero shall continue operation of its existing WGS to control emissions from the Texas City FCCU. Valero shall comply with SO₂ concentration emission limits of no greater than 25 ppmvd, measured as a 365-day rolling average, and 50 ppmvd, measured as a 7-day rolling average, both at 0% O₂.

L. Golden Eagle

82. By no later than September 30, 2006, Tesoro shall operate the Golden Eagle FCCU and comply with SO₂ concentration emission limits of no greater than 25 ppmvd, measured as a 365-day rolling average, and 50 ppmvd, measured as a 7-day rolling average, both at 0% O₂.

Nothing in this Consent Decree is intended or shall be construed to limit the methods available to



Tesoro under the BAAQMD rules and regulations for compliance with Sections 9-10-301 and 9-10-403 thereof; provided however, no credits generated under the BAAQMD rules and regulations may be banked, traded or sold to another facility as provided in Paragraph 296(d).

M. Additional Provisions

83. Reserved.

84. Nothing in this Consent Decree is intended or shall be construed to limit the ability of Valero to generate, bank or use RTCs under the SCAQMD RECLAIM rules and regulations; provided however, no credits generated under the SCAQMD rules and regulations may be traded or sold to another facility, as is expressly proscribed by Paragraph 296(d). In the event that EPA, the SCAQMD, the SCAQMD Hearing Board or a court of competent jurisdiction should finally determine that the Consent Decree prohibits or limits the ability of Valero to generate, bank or use RTCs from emission reductions at the Wilmington FCCD, then Valero may elect, upon written notice to EPA, to render null and void the provisions of Part VI of this Consent Decree, as such provisions relate to the Wilmington FCCD. In the event that Valero provides written notice to EPA of such election pursuant to this paragraph, then the release from liability under Part XXIV applicable to PSD requirements relating to S02 emissions from the FCCD at the Wilmington Refinery shall be rendered null and void. In lieu of providing such notice to EPA Valero may propose and EPA may agree to allow Valero to implement such actions sufficient to satisfy the obligations of Section VLC as if such section had remained in full force and effect notwithstanding an adverse determination by EPA, the SCAQMD, the SCAQMD Hearing board or a court of competent jurisdiction with respect to the Wilmington Refinery. If such an agreement is reached, committed to writing and signed by Valero and EPA, then the release from

liability under Part XXIV of this Consent Decree applicable to SO₂ emissions from the Wilmington FceD shall not be rendered void under this paragraph.

85. By no later than December 31, 2005, Valero and/or Tesoro, as applicable, may elect, on a refinery-specific basis for any refinery that hydrotreats feed to the FCCD that is not equipped with a WGS or regenerative scrubber, to submit for approval by EPA, after an opportunity for consultation with the affected Plaintiff-Intervener, a plan for the operation of the FCCD (including associated air pollution control equipment) during hydrotreater outages. Any such plan shall provide for the minimization of emissions during hydrotreater outages to the extent practicable. The plan shall consider, at a minimum, the use of low sulfur feed, storage of hydrotreated feed and an increase in additive addition rate. Any short term emission limits established pursuant to this Consent Decree shall not apply during periods of hydrotreater outage provided that Valero and/or Tesoro, as applicable, is in compliance with any plan submitted by Valero and/or Tesoro, as applicable, under this paragraph for the respective FceD and is maintaining and operating the FceD in a manner consistent with good air pollution control practices. In order for the relief for short-term emission limits afforded by this paragraph to apply to a period of hydrotreater outage, Valero and/or Tesoro, as applicable, shall comply with the relevant refinery-specific plan approved by EPA under this paragraph at all times, including periods of startup, shutdown or malfunction of the hydrotreater. In addition, in the event that Valero and/or Tesoro, as applicable, asserts that the basis for a specific hydrotreater outage for which Valero and/or Tesoro, as applicable, seeks to secure the relief from short term emission limits provided under this paragraph is a shutdown (where no catalyst change out occurs) required by ASME pressure vessel requirements or applicable state boiler requirements, Valero

and/or Tesoro, as applicable, shall submit to EPA a report that identifies the relevant requirements and justifies Valero's and/or Tesoro's, as applicable, decision to implement the shutdown during the selected time period. For the purposes of this Paragraph 85, "hydrotreater" shall include any units that hydrotreat or otherwise desulfurize FCCD feedstocks or the feedstocks to the Corpus Christi West HOC.

86. Notwithstanding any provision of this Consent Decree to the contrary and in lieu of complying with any specific SO₂ emission control requirements established pursuant to this Part VI, other than a WAS or regenerative scrubber, Valero may elect to limit emissions from any FCCU at a Valero Refinery or the Corpus Christi West HOC to SO₂ concentrations of 25 ppmvd or less, measured as a 365-day rolling average, and 50 ppmvd or less, measured as a 7-day rolling average, each at 0% O₂ including without limitation by permanently shutting down such FCCD or by application of any emission reduction method or technology, including any technology not specified in this Consent Decree. Notwithstanding any provision of this Consent Decree to the contrary and in lieu of complying with any specific SO₂ emission control requirements established pursuant to this Part VI for a WAS or regenerative scrubber, Valero may elect to shut down such Refinery's FCCD. In the event that Valero elects to demonstrate compliance with this Part VI for a specific FCCU or the Corpus Christi West HOC by complying with this paragraph, then Valero must achieve compliance with this paragraph for such FCCD or the Corpus Christi West HOC by no later than the refinery-specific compliance date for completion of the demonstration period identified in Appendix E or as otherwise specified in this Part VI. Valero's election to satisfy its obligations under this Part VI for any Valero Refinery subject to this Consent Decree through compliance with this paragraph shall not limit the

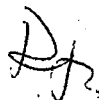

applicability or extent of Part XXIV (Effect of Settlement) with respect to such FCCU or the Corpus Christi West Hac.

87. Notwithstanding any provision of this Consent Decree to the contrary, in the event that Valero installs a regenerative scrubber to control S02 emissions from the FCCU or the Corpus Christi West HOC at a refinery otherwise obligated to install aWGS under this Consent Decree, then in lieu of complying with any refinery-specific S02 emission control requirements established pursuant to this Part VI, Valero must design and operate the regenerative scrubber and thereafter comply with S02 concentration emission limits at the point of emission to the atmosphere of no greater than 25 ppmvd, measured as a 365-day rolling average, and 50 ppmvd, measured as a 7-day rolling average, both at 0% O₂. Notwithstanding the foregoing, if Valero demonstrates to EPA's satisfaction that the total installed cost for such a regenerative WGS is more than 105% of the current (at the time of design) total installed cost for a regenerative WGS designed to achieve a 95% reduction in S02 emissions and upon EPA approval of such design in consideration of Appendix L, Valero shall construct and operate such scrubber and comply with concentration emission limits based upon at least a 95% reduction in S02 emissions attributable to such FCCU or the Corpus Christi West HOC, such emission limits are to be established by EPA after Valero conducts an optimization study and demonstration program under Paragraph 88. In the event that Valero demonstrates compliance with this Part VI for a specific FCCD or the Corpus Christi West HOC by complying with this paragraph, then Valero must complete construction and begin optimization by the refinery-specific compliance date otherwise specified in this Part VI. Valero's satisfaction of its obligations under this Part VI for any Valero Refinery subject to this Consent Decree through compliance with this paragraph shall not limit the

applicability or extent of Part XXIV (Effect of Settlement) with respect to such FCCD or the Corpus Christi West HOC.

88. Scrubber Optimization Studies and Demonstration Periods.

a. This Paragraph 88 applies only to regenerative scrubbers as provided under Paragraphs 67 and 87. Valero will submit to EPA a protocol for implementing such optimization studies at each of the applicable FCCDs. This protocol will include, at a minimum, consideration of the operating parameters set forth in Appendix L to this Consent Decree.

b. Valero will begin a six (6) month optimization study, in accordance with the protocol, to optimize the performance of the scrubber to minimize emissions from the respective FCCDs ("Optimization Study"). During the Optimization Study, Valero will: evaluate the effect of operating parameters on SO₂ emissions; monitor SO₂ emissions and the operating parameters to identify optimum operating levels for the parameters that minimize emissions; and operate the scrubber in a way that minimizes SO₂ emissions as much as feasible without interfering with FCCD conversion or processing rates.

c. Within sixty (60) days of completion of the Optimization Study, Valero will submit a report to EPA and the applicable Plaintiff-Intervener that describes the results of the Optimization Study ("Optimization Study Report") and identifies optimal operating levels for use in the demonstration period by no later than the refinery-specific compliance date otherwise specified in this Part VI. Valero will propose for EPA approval, after an opportunity for review and comment by the applicable Plaintiff-Intervener, optimal operating levels for use in the demonstration period. If EPA does not approve Valero's proposed operating levels prior to the

commencement of the demonstration period, Valero may nonetheless proceed with the demonstration.

d. Valero will conduct a twenty-four (24) month demonstration of each such scrubber at its approved optimized operating levels. During the demonstration Valero will continue to evaluate the effect of operating parameters on SO₂ emissions and will operate the scrubber in a way that minimizes SO₂ emissions as much as feasible.

e. By no later than sixty (60) days after completion of the demonstration, Valero will submit a written report ("Demonstration Report") to EPA and the applicable Plaintiff-Intervener that sets forth the results of the demonstration.

f. In the Optimization Study and Demonstration Reports, Valero will identify the relevant scrubber operating parameters and their levels that result in the maximum reduction of SO₂ emissions from each respective FCCU. The Reports will include, at a minimum, all of the optimization parameters in Appendix L as well as the following information on a daily average basis (except where a different period is specified):

- (i) Coke burn rate in pounds per hour;
- (ii) FCCU feed rate in barrels per day;
- (iii) FCCU feed API gravity;
- (iv) Estimated percentage or directly measured percentage (if available) of each type of FCCU feed component (i.e. atmospheric gas oil, vacuum gas oil, atmospheric tower bottoms, vacuum tower bottoms, etc.);
- (v) Amount and type of hydrotreated feed (i.e. volume % of feed that is hydrotreated and the type of hydrotreated feed such as AGO, VGO, CGO, ATB, VTB, etc.);
- (vi) FCCU feed sulfur (on a daily basis) content, as a weight %;

(vii) CO boiler firing rate and fuel type, if applicable;

(viii) Hourly average SO₂ and O₂ concentrations at the point of emission to the atmosphere and, for O₂ only, in the flue gas leaving the CO Boiler; and

(ix) Any other parameters that Valero identifies before the end of the demonstration period.

Upon request by EPA, Valero will submit any reasonably available additional data that EPA determines it needs to evaluate the Optimization Study and/or Demonstration Report.

g. Valero shall propose a short-term (7-day rolling average) and a long-term (365-day rolling average) (ppmvd) SO₂ concentration emission limit as measured at 0% O₂ for each FCCD in its Demonstration Report. Valero will comply with the concentration emission limits it proposes for each FCCD beginning immediately upon submission of the applicable report for that FCCD. Valero will continue to comply with these limits unless and until Valero is required to comply with the concentration emissions limits set by EPA based on data obtained during the optimization and demonstration periods, as well as other available and relevant information, determined by EPA to provide for a reasonable certainty of compliance, considering operational variability and variability in feedstocks. At any point in time during the optimization study and/or demonstration, Valero may elect to take permit limits of no greater than 25 ppmvd, measured as a 365-day rolling average and 50 ppmvd, measured as a 7-day rolling average, both at 0% O₂ in lieu of further optimization or demonstration from and after notice to EPA of its binding election to accept such limits.

N. Monitoring Emissions and Demonstrating Compliance

89. Beginning no later than the dates set forth below for each FCCD, Valero shall use 802 and O₂CEMS to monitor performance of the FCCD and to report compliance with the terms and conditions of this Consent Decree:

(a) Ardmore-Next scheduled turnaround (currently anticipated to occur in 2005) or such compliance date established pursuant to Paragraph 64

(b) Benicia-the later of March 31, 2006 or 180 days following EPA approval of the 802 site specific monitoring plan described in Paragraph 93.

(c) Corpus Christi East- December 31, 2005

(d) Corpus Christi West-Date of Lodging

(e) Denver - June 30, 2006

(f) Houston-June 30, 2007

(g) Krotz Springs - December 31, 2006

(h) McKee-June 30, 2006

(i) Paulsboro-Date of Lodging

(j) St. Charles - Date of Lodging

(k) Texas City-Date of Lodging

(l) Three Rivers--December 31, 2006

(m) Wilmington - December 31, 2005

90. CEMS will be used to demonstrate compliance with the respective S₀₂ concentration emission limits established pursuant to this Part VI. Valero and Tesoro, as applicable, shall make CEMS data available to EPA and any appropriate Plaintiff-Intervener upon demand as soon as practicable. Except as specified in Paragraph 93, Valero shall install, certify, calibrate,

maintain and operate all CEMS required by this paragraph in accordance with the provisions of 40 C.F.R. § 60.13 that are applicable to CEMS (excluding those provisions applicable only to continuous opacity monitoring systems) and Part 60, Appendices A and F, and the applicable performance specification test of 40 C.F.R. Part 60, Appendix B. With respect to 40 C.F.R. Part 60 Appendix F, in lieu of the requirements of 40 C.F.R. Part 60, Appendix F §§ 5.1.1, 5.1.3 and 5.1.4, the Companies must conduct either a RAA or a RATA on each CEMS at least once every three (3) years. The Companies must also conduct a CGA each calendar quarter during which a RAA or a RATA is not performed. With respect to their Benicia and Golden Eagle Refineries, Valero and Tesoro, as applicable, may conduct a FAT, as defined in BAAQMD regulations or procedures, in lieu of the required RAA or CGA.

91. By September 30, 2006, Tesoro shall install and commence operation of an S02 CEMS to measure S02 emissions and to report compliance with the terms and conditions of the Consent Decree at the Golden Eagle FCCD.

92. All CEMS data collected by Valero or Tesoro during the effective life of the Consent Decree shall be made available by Valero or Tesoro, as applicable, to EPA upon demand as soon as practicable.

93. Within 90 days of the Date of Entry, Valero shall submit to EPA a complete site specific monitoring plan for utilizing a combination of S02/TRS CEMS upstream of the CO boiler at the Benicia Refinery. A new CEMS must be installed in the existing ductwork upstream of the CO boiler in order to monitor S02/TRS in the FCCD flue gas prior to mixing with the Coker Unit flue gas. The existing ductwork configuration may make it impossible to

meet all Appendix A requirements for CEMS locations. Valero will locate the CEM in the most appropriate location available.

VII. CO, OPACITY AND PARTICULATE EMISSIONS FROM FCCUs

Program Summary: Valero and Tesoro shall implement a program to limit CO and particulate emissions from their FCCDs and shall implement monitoring at each FCCD sufficient to demonstrate compliance with emission standards specified in this Part.

94. CO Emission Standard. Valero shall limit CO emissions from the FCCDs at Valero's Refineries subject to this Consent Decree to 500ppmvd (at 0% O₂), measured as a one-hour block average, in accordance with the schedule identified herein. Tesoro shall limit CO emissions from the FCCD at the Golden Eagle Refinery to 500ppmvd (at 0% O₂), measured as a one-hour block average, in accordance with the schedule identified in Paragraph 99.

95. Particulate Emission Standard. Valero shall limit particulate emissions from the FCCDs at Valero's Refineries and the Corpus Christi West HOC subject to this Consent Decree to one (1) pound per 1,000 pounds of coke burned (front half only according to Method 5B or 5F, as appropriate), measured as a one-hour average over three performance test runs, in accordance with the schedule identified herein. Tesoro shall limit particulate emissions from the FCCD at the Golden Eagle Refinery to one (1) pound per 1,000 pounds of coke burned (front half only according to Method 5B or 5F, as appropriate), measured as a one-hour average over three performance test runs, in accordance with the schedule identified in Paragraph 99.

96. Except as specified in Paragraphs 104 and 105 and by no later than one hundred eighty (180) days from the Date of Entry of this Consent Decree, Valero shall ensure that the FCCDs located at the Benicia, Corpus Christi West, Houston, McKee, Paulsboro and Texas City Refineries shall comply with the CO, opacity and particulate emission standards specified in

Paragraphs 94 and 95, respectively, and all applicable requirements of 40 C.F.R. Part 60, Subparts A and J, as such requirements relate to CO, opacity and particulate emissions from FCCU regenerators and the Corpus Christi West HOC.

97. Except as specified in Paragraph 104 and by no later than December 31, 2006, Valero shall ensure that the FCCUs located at the Ardmore, Corpus Christi East, Krotz Springs, 81. Charles, Three Rivers and Wilmington Refineries comply with the CO, opacity and particulate emission standards specified in Paragraphs 94 and 95, respectively, and all applicable requirements of 40 C.F.R. Part 60, Subparts A and J, as such requirements relate to CO, opacity and particulate emissions from FCCU regenerators.

98. By no later than December 31, 2009, Valero shall ensure that the FCCU located at the Denver Refinery complies with the CO, opacity and particulate emission standards specified in Paragraphs 94 and 95, respectively, and all applicable requirements of 40 C.F.R. Part 60, Subparts A and J, as such requirements relate to CO, opacity and particulate emissions from FCCU regenerators.

99. By no later than September 30, 2006, Tesoro shall ensure that the FCCU located at the Golden Eagle Refinery complies with the CO, opacity and particulate emission standards specified in Paragraphs 94 and 95, respectively, and all applicable requirements of 40 C.F.R. Part 60, Subparts A and J, as such requirements relate to CO, opacity and particulate emissions from FCCU regenerators.

100. Lodging of this Consent Decree shall satisfy any obligation otherwise applicable to Valero or Tesoro to provide notification in accordance with 40 C.F.R. Part 60, Subparts A and J, including without limitation 40 C.F.R. § 60.7, with respect to the provisions of 40 C.F.R. Part 60,

Subparts A and J, as such requirements relate to CO, opacity and particulate emissions from FCCU regenerators.

101. CEMS or an EPA approved alternative monitoring plan or monitoring waiver will be used to demonstrate compliance with the respective CO emission limits established pursuant to this Part VII. Valero and Tesoro shall make CEMS data available to EPA and any appropriate Plaintiff-Intervener upon demand as soon as practicable. The Companies shall install, certify, calibrate, maintain and operate all CEMS required by this paragraph in accordance with the provisions of 40 C.F.R. § 60.13 that are applicable to CEMS (excluding those provisions applicable only to continuous opacity monitoring systems) and Part 60, Appendices A and F, and the applicable performance specification test of 40 C.F.R. Part 60, Appendix B. With respect to 40 C.F.R. Part 60 Appendix F, in lieu of the requirements of 40 C.F.R. Part 60, Appendix F §§ 5.1.1, 5.1.3 and 5.1.4, the Companies must conduct either a RAA or a RATA on each CEMS at least once every three (3) years. The Companies must also conduct a CGA each calendar quarter during which a RAA or a RATA is not performed. To the extent that the Companies have conducted any performance testing of the relevant unit for PM emissions, and such performance testing was conducted in accordance with the procedures specified in EPA Method 5B or 5F, as appropriate, of 40 C.F.R. Part 63, Subpart UUU, and demonstrated compliance with the emission limits established under this part, then such performance testing shall satisfy any obligation otherwise applicable under this Part to conduct performance testing under 40 C.F.R. Part 60, Subparts A and J. Any future performance testing performed by Valero or Tesoro, as applicable, to demonstrate compliance with the particulate emission limitations established by this Part shall

be conducted in accordance with EPA Method 5B or SF, as appropriate, set forth at 40 C.F.R. Part 60, Appendix A.

102. The CO, opacity, and particulate limits established pursuant to this Part VII shall not apply during periods of startup, shutdown or malfunction of the FCCDs or malfunction of the applicable CO or particulate control equipment, if any, provided that during startup, shutdown or malfunction, Valero or Tesoro, as applicable, shall, to the extent practicable, maintain and operate the relevant affected facility, including associated air pollution control equipment, in a manner consistent with good air pollution control practices for minimizing emissions.

103. Continuous Opacity Monitoring System (CaMS) or an approved AMP will be used to demonstrate compliance with the respective opacity limits established pursuant to this Part VII. Valero or Tesoro, as applicable, shall make CaMS data available to EPA and any appropriate Plaintiff-Intervener upon demand as soon as practicable. Valero or Tesoro, as applicable, shall install, certify, calibrate, maintain and operate all COMS required by this paragraph in accordance with the provisions of 40 C.F.R. §60.11, §60.13, and Part 60 Appendix A, and the applicable performance specification test in 40 C.F.R. Part 60 Appendix B.

104. Within 180 days of the Date of Entry of the Consent Decree, Valero will have submitted or shall submit to EPA complete opacity alternative monitoring plan ("AMP") applications for the FCCDs located at Ardmore, Corpus Christi West, Paulsboro, 81. Charles, Three Rivers and Texas City. At least 180 days prior to the startup of the WGS or regenerative scrubber at Houston and the Selected Refinery, Valero will have submitted or shall submit to EPA preliminary opacity alternative monitoring plan ("AMP") applications. If such AMPs are not approved, Valero shall within ninety (90) days of receiving notice of such disapproval either

invoke the dispute resolution provisions of Part XXIII or submit to EPA for approval, with a copy to the appropriate Plaintiff-Intervener, a plan and schedule that provides for compliance with the applicable monitoring requirements under NSPS Subpart J as soon as practicable. Such plan may include a revised AMP application, physical or operational changes to the equipment, or additional or different monitoring. These FCCUs shall not be subject to the applicable requirements of 40 C.F.R. Part 60, Subparts A and J, as such requirements relate to opacity from FCCU regenerators until EPA approves AMPs for opacity or Valero complies with the above-identified requirements of this paragraph.

105. Within 180 days of the Date of Entry of the Consent Decree, Valero shall submit to EPA complete alternative monitoring plan ("AMP") applications to utilize engineering calculations to convert CO and opacity emission data recorded by the CEMS on, and particulate emission data measured during the performance test of, the Benicia combined FCCU/Fluid Coker emissions to equivalent CO, opacity, and particulate emissions from the FCCU. If such AMPs are not approved, Valero shall within ninety (90) days of receiving notice of such disapproval either invoke the dispute resolution provisions of Part XXIII or submit to EPA for approval, with a copy to the appropriate Plaintiff-Intervener, a plan and schedule that provides for compliance with the applicable monitoring requirements under NSPS Subpart J as soon as practicable. Such plan may include a revised AMP application, physical or operational changes to the equipment, or additional or different monitoring. The Benicia FCCU shall not be an affected facility under NSPS Subpart A and J by virtue of this Consent Decree until EPA approves these AMPs or Valero complies with the above-identified requirements of this paragraph.

106. Nothing in this Consent Decree shall be interpreted to limit Valero's or Tesoro's opportunity to propose to EPA an alternative compliance monitoring plan (AMP) under 40 C.F.R. Part 60, Subpart A, for CO, opacity or particulate emissions from FCCUs under NSPS Subpart J.

VIII. NSPS APPLICABILITY TO SO₂ EMISSIONS FROM FCCU

REGENERATORS

Program Summary: Valero and Tesoro shall comply with all requirements of 40 C.F.R. Part 60, Subparts A and J, as such provisions relate to SO₂ emissions from FCCU Regenerators, by the deadlines specified in this Part.

107. Valero's FCCU Regenerators at the following refineries shall be considered "affected facilities" pursuant to 40 C.F.R. Part 60, Subpart J, and shall comply with all requirements of 40 C.F.R. Part 60, Subparts A and J, as such provisions relate to SO₂ emissions from FCCU Regenerators, on the later of the following dates:

- (a.) Ardmore FCCU Regenerators – December 31, 2005 or such compliance date established pursuant to Paragraph 64
- (b.) Benicia FCCU Regenerator - December 31, 2011 or as specified in Paragraph 111.
- (c.) Corpus Christi East FCCU Regenerator - Upon completion of the installation or implementation of the relevant controls required in Part VI
- (d.) Corpus Christi West FCCD Regenerator - Upon Date of Entry
- (e.) Denver FCCU Regenerator - Upon completion of the installation or implementation of the relevant controls required in Part VI
- (f.) Houston FCCU Regenerator - March 31, 2007
- (g.) Krotz Springs - June 30, 2010 or as specified in Paragraph 111.
- (h.) McKee FCCD Regenerator - December 31, 2009 or as specified in Paragraph 111.

- (i.) Paulsboro FCCU Regenerator - Date of Lodging
- G.) St. Charles -- Upon Date of Entry
- (k.) Texas City FCCU Regenerator - Date of Lodging
- (l.) Three Rivers FCCU Regenerator-. December 31, 2006
- (m.) Wilmington Fce u Regenerator - upon completion of the installation or implementation of the relevant controls required in Part VI

107A. Tesoro's FCCU Regenerator at the Golden Eagle Refinery shall be considered an "affected facility" pursuant to 40 e.F.R. Part 60, Subpart J, and shall comply with all requirements of 40 C.F.R. Part 60, Subparts A and J, as such provisions relate to S02 emissions from FeCUREgenerators, by September 30, 2006.

108. Lodging of this Consent Decree shall satisfy any obligation otherwise applicable to Valero or Tesoro to provide notification in accordance with 40 C.F.R. Part 60, Subparts A and J, including without limitation 40 C.F.R. § 60.7, with respect to the provisions of 40 C.F.R. Part 60, Subparts A and J; as such provisions relate to S02 emissions from FCCU Regenerators.

109. CEMS will be used to demonstrate compliance with the respective S02 emission limits established pursuant to this Part VIII. Valero and Tesoro shall make CEMS data available to EPA and any appropriate Plaintiff-Intervener upon demand as soon as practicable. The Companies shall install, certify, calibrate, maintain and operate all CEMS required by this paragraph in accordance with the provisions of 40 C.F.R. § 60.13 that are applicable to CEMS (excluding those provisions applicable only to continuous opacity monitoring systems) and Part 60, Appendices A and F, and the applicable performance specification test of 40 C.F.R. Part 60, Appendix B. With respect to 40 e.F.R. Part 60 Appendix F, in lieu of the requirements of 40

C.F.R. Part 60, Appendix F §§ 5.1.1, 5.1.3 and 5.1.4, the Companies must conduct either a RAA or a RATA on each CEMS at least once every three (3) years. The Companies must also conduct a CGA each calendar quarter during which a RAA or a RATA is not performed. With respect to the Benicia and Golden Eagle Refineries, Valero and Tesoro, as applicable, may conduct a FAT, as defined in BAAQMD regulations or procedures, in lieu of the required RAA or CGA.

110. The SO₂ limits established pursuant to this Part shall not apply during periods of startup, shutdown or malfunction of the FCCDs and hydrotreaters or the malfunction of SO₂ control equipment, if any, provided that during startup, shutdown or malfunction, Valero or Tesoro, as applicable, shall, to the extent practicable, maintain and operate the relevant affected facility, including associated air pollution control equipment, in a manner consistent with good air pollution control practices for minimizing emissions.

111. Within 270 days of the Date of Entry of the Consent Decree, Valero shall submit to EPA a complete alternative monitoring plan ("AMP") application for NSPS Subpart J monitoring for SO₂ at the Krotz Springs and McKee FCCUs. No later than December 31, 2007, Valero shall submit to EPA a complete alternative monitoring plan ("AMP") application for NSPS Subpart J monitoring for SO₂ at the Benicia Refinery and, if necessary, the refineries that are not the Selected Refinery identified in Paragraph 70. If any such AMP is not approved, Valero shall within ninety (90) days of receiving notice of such disapproval submit to EPA for approval, with a copy to the appropriate Plaintiff-Intervener, a plan and schedule that provides for compliance with the applicable monitoring requirements under NSPS Subpart J as soon as

practicable. Such plan may include a revised AMP application, physical or operational changes to the equipment, or additional or different monitoring.

112. Nothing in this Consent Decree shall be interpreted to limit Valero's or Tesoro's opportunity to propose to EPA an alternative compliance monitoring plan under 40 C.F.R. Part 60, Subpart A, for SO₂ emissions from FCCD regenerators.

IX. SO₂ AND NSPS REQUIREMENTS FOR HEATERS AND BOILERS

Program Summary: Valero shall undertake the following measures at Valero Refineries covered by this Consent Decree, and Tesoro shall undertake the following measures at the Golden Eagle Refinery, to reduce SO₂ emissions from heaters and boilers by eliminating or minimizing the burning of fuel oil and complying with 40 C.F.R. Part 60, Subparts A and J, as such provisions apply to fuel gas combustion devices.

113. By no later than December 31, 2005, Valero shall discontinue the burning or combustion of Fuel Oil in any of the heaters and boilers at Valero's Refineries, and Tesoro shall discontinue the burning or combustion of Fuel Oil in any of the heaters and boilers at the Golden Eagle Refinery, except as provided in Paragraph 114. For purposes of this Consent Decree, "Fuel Oil" shall mean fuel that is predominantly in the liquid phase at the point of combustion with a sulfur content of greater than 0.05% by weight.

114. Notwithstanding any provision of this Consent Decree to the contrary, Fuel Oil may be combusted or burned during periods of natural gas curtailment by suppliers or during periods approved by EPA for purposes of test runs and operator training at any refinery subject to this Consent Decree. During any such period of natural gas curtailment, test runs or operator training, only low sulfur (0.2% sulfur until December 31, 2007, 0.05 wt % sulfur thereafter) Fuel Oil shall be combusted or burned. Prior to conducting test runs or operator training at a refinery during which Fuel Oil will be burned pursuant to this paragraph, Valero or Tesoro, as

D.J.

applicable, shall submit proposed schedules for such test runs or training periods to EPA for review and approval; In the event that EPA does not respond to such proposed schedules within thirty (30) days of submission pursuant to this paragraph, then such proposed schedules shall be deemed approved in accordance with the proposals submitted.

liS. By no later than December 31, 2007, Valero shall ensure that all heaters and boilers located at the Benicia, Corpus Christi West, Denver, Houston, Krotz Springs, St. Charles, Texas City and Wilmington Refineries are "affected facilities" as fuel gas combustion devices, for purposes of 40 C.F.R. Part 60, Subpart J, and shall comply with all requirements of 40 C.F.R. Part 60, Subparts A and J, as such requirements apply to fuel gas combustion devices.

liSA. By no later than December 31, 2008, Valero shall ensure that all heaters and boilers located at the Paulsboro Refinery are "affected facilities" as fuel gas combustion devices, for purposes of 40 C.F.R. Part 60, Subpart J, and shall comply with all requirements of 40 C.F.R. Part 60, Subparts A and J, as such requirements apply to fuel gas combustion devices.

116. By no later than December 31, 2010, Valero shall ensure that all heaters and boilers located at the Ardmore, Corpus Christi East, McKee and Three Rivers Refineries are "affected facilities" as fuel gas combustion devices, for purposes of 40 C.F.R. Part 60, Subpart J, and shall comply with all requirements of 40 C.F.R. Part 60, Subparts A and J as such requirements apply to fuel gas combustion devices.

117. By no later than December 31, 2006, Tesoro shall ensure that all heaters and boilers located at the Golden Eagle Refinery are "affected facilities" as fuel gas combustion devices, for purposes of 40 C.F.R. Part 60, Subpart J, and shall comply with all requirements of 40 C.F.R. Part 60, Subparts A and J as such requirements apply to fuel gas combustion devices.

118. By no later than the dates specified in Paragraphs 115 - 117, all heaters and boilers at such refineries shall comply with the applicable requirements of NSPS Subpart A and J for fuel gas combustion devices, except for those heaters or boilers listed in Appendix O, which shall be affected facilities and shall be subject to and comply with the requirements of NSPS Subparts A and J for fuel gas combustion devices by the dates listed in Appendix O. All CEMS installed pursuant to this paragraph shall be installed; certified, calibrated, maintained and operated in accordance with the applicable requirements of 40 C.F.R. §§ 60.11 and 60.13 and 40 C.F.R. Part 60, Appendix F as provided in Paragraph 121 below.

119. Within two (2) years of Entry of the Consent Decree, Valero or Tesoro, as applicable, may submit to EPA complete alternative monitoring plan ("AMP") applications for NSPS Subpart J monitoring fuel gas combustion devices. They shall submit a complete AMP application to EPA and the appropriate Plaintiff-Intervener. If such AMP is not approved, they shall within ninety (90) days of receiving notice of such disapproval submit to EPA for approval, with a copy to the appropriate Plaintiff-Intervener, a plan and schedule that provides for compliance with the applicable monitoring requirements under NSPS Subpart J as soon as practicable. Such plan may include a revised AMP application, physical or operational changes to the equipment, or additional or different monitoring. For some heaters and boilers that combust low-flow VOC streams from vents, pump seals and other sources, it is anticipated that some AMP applications will rely in part on calculating a weighted average H₂S concentration of all VOC and fuel gas streams that are burned in a single heater or boiler and demonstrating with alternative monitoring that either the SO₂ emissions from the heater or boiler will not exceed 20 ppm or that the weighted average H₂S concentration is not likely to exceed 162 ppm H₂S. EPA

shall not reject an AMP solely due to the AMP's use of one of these approaches to demonstrating compliance with NSPS Subpart J.

120. Lodging of this Consent Decree shall satisfy any obligation otherwise applicable to Valero or Tesoro to provide notification in accordance with 40 C.F.R. Part 60, Subparts A and J, including without limitation 40 C.F.R. § 60.7, with respect to the provisions of 40 C.F.R. Part 60, Subparts A and J, as such requirements apply to fuel gas combustion devices.

121. The CEMS or approved AMPs will be used to demonstrate compliance with the respective *H₂S/SO₂* concentration emission limits established pursuant to this Part IX. Valero or Tesoro, as applicable, shall make CEMS data available to EPA and any appropriate Plaintiff-Intervener upon demand as soon as practicable. Valero or Tesoro, as applicable, shall install, certify, calibrate, maintain and operate all CEMS required by this paragraph in accordance with the provisions of 40 C.F.R. § 60.13 that are applicable to CEMS (excluding those provisions applicable only to continuous opacity monitoring systems) and Part 60, Appendices A and F, and the applicable performance specification test of 40 C.F.R. Part 60, Appendix B. With respect to 40 C.F.R. Part 60 Appendix F, in lieu of the requirements of 40 C.F.R. Part 60, Appendix F §§ 5.1.1, 5.1.3 and 5.1.4, Valero or Tesoro, as applicable, must conduct either a RAA or a RATA on each CEMS at least once every three (3) years. Valero or Tesoro, as applicable, must also conduct a CGA each calendar quarter during which a RAA or a RATA is not performed. With respect to its Benicia and Golden Eagle Refineries, Valero or Tesoro, as applicable, may conduct a FAT, as defined in BAAQMD regulations or procedures, in lieu of the required RAA or CGA.

122. The SO₂ limits established pursuant to this Part shall not apply during periods of startup, shutdown or malfunction of the heaters and boilers or the malfunction of SO₂ control

equipment, if any, provided that during startup, shutdown or malfunction, Valero or Tesoro, as applicable, shall, to the extent practicable, maintain and operate the relevant affected facility including associated air pollution control equipment in a manner consistent with good air pollution control practices for minimizing emissions.

X. BENZENE WASTE NESHAP PROGRAM ENHANCEMENTS

Program Summary: Valero and Tesoro shall undertake the following measures to minimize fugitive benzene waste emissions at each of the Refineries that are covered by this Consent Decree.

123. Valero agrees to undertake the measures set forth in this Part X, which establish enhancements to applicable requirements of 40 C.F.R. Part 61, Subpart FF ("Benzene Waste NESHAP" or "Subpart FF"), and which will minimize or eliminate fugitive benzene waste emissions at Valero's Refineries. Tesoro agrees to undertake the measures set forth in this Part X to minimize or eliminate fugitive benzene waste emissions at Tesoro's Golden Eagle Refinery.

A. Compliance Status and Schedule.

124. Valero shall comply with the compliance options specified below:

(1.) . Valero's Paulsboro, Ardmore, Corpus Christi West, Three Rivers, Texas City, McKee, Wilmington and Benicia Refineries, and Tesoro's Golden Eagle Refinery shall comply with the compliance option set forth at 40 C.F.R. 61.342(e) (herein referred to as the "6 BQ compliance option"), to the extent they continue to have total annual benzene ("TAB") quantities >10 megagrams per year ("*Mg/yr*"). By no later than June 30, 2005, the Ardmore, Corpus Christi West, Three Rivers, Texas City, McKee, Wilmington, Benicia and Tesoro's Golden Eagle refineries shall complete implementation of all actions necessary to ensure compliance

with the 6 BQ compliance option pursuant to the provisions of this Part X of this Consent Decree.

(2.) By no later than June 30, 2005, the Paulsboro refinery shall complete implementation of all actions necessary to ensure compliance with the 6 BQ compliance options, except for two projects: control of certain groundwater streams; and control of certain tank waterdraw streams. By January 31, 2006, Valero shall complete all actions associated with these two Paulsboro projects and, by February 28, 2006, certify to EPA and the appropriate Plaintiff-Intervener that the Paulsboro refinery is in compliance with the Benzene Waste NESHP.

(3.) Valero's Houston, Krotz Springs, St. Charles and Denver Refineries (referred to hereafter as "Exempt Refineries") have reported that their TAB quantities are <10 Mg/yr and that they were not subject to the control requirements of 40 C.F.R. § 61.342(b) and (c).

(4.) Valero's Corpus Christi East Refinery shall continue to comply with the compliance option set forth at 40 C.F.R. § 61.342(c), utilizing the exemptions set forth in 40 C.F.R. § 61.342(c)(2) and (c)(3)(ii) (hereinafter referred to as the "2 Mg compliance option").

125. On or before June 30, 2005, Valero shall provide written notice to EPA on whether Valero intends to manage one or more of the Exempt Refineries under the 6 BQ compliance option (the "Elective 6 BQ Refineries"). On or before September 30, 2006, Valero shall complete implementation of any actions that may be necessary to ensure that the Elective 6 BQ Refineries comply with all standards of Subpart FF that are applicable to facilities utilizing the 6 BQ compliance option, including the monitoring, recordkeeping and reporting requirements of 40 C.F.R. §§ 61.354, 61.356 and 61.357, respectively, as applicable to facilities utilizing the 6 BQ compliance option.

1. In providing its written notification identifying the Elective 6 BQ Refineries under this Paragraph 125, Valero shall submit to EPA an identification of all closed-vent systems and control devices that already are operational at such refineries that meet the standards of 40 C.F.R. § 61.349. Valero shall continue to operate the identified systems or devices, unless Valero notifies EPA in writing of its intent to discontinue the operation of any such system or device, describes its reasons for seeking to discontinue the use, and EPA approves of the proposal to discontinue use of the device. In the event that EPA objects under this subparagraph to Valero's proposed discontinuation of the operation of any such closed-vent systems or control devices, the parties shall confer and attempt to resolve their dispute. Any dispute that cannot be resolved within thirty (30) days of EPA's notice of objection hereunder may be submitted for Dispute Resolution pursuant to Part XXIII.

ii. Organic Benzene Wastes. By no later than September 30, 2006 and continuing until termination, Valero shall manage and treat all "organic" benzene waste streams, as defined in Subpart FF, at each Elective 6 BQ Refinery in accordance with the requirements of Subpart FF.

iii. Aqueous Benzene Wastes. Commencing no later than September 30, 2006 and continuing until termination, Valero shall manage and treat all aqueous benzene wastes, as defined in Subpart FF, at each Elective 6 Refinery in accordance with the provisions of Paragraph 160.

iv. Certification of Completion of Compliance Matters. By no later than December 1, 2006, Valero shall submit to EPA a report that describes the actions that Valero took to comply with the provisions of this Paragraph 125. As part of that report, Valero shall certify completion

of the requirements and that the Elective 6 BQ Refineries comply with the 6 BQ compliance option. If, after a review of the written report, EPA determines that any requirements have not been completed in accordance with this Consent Decree, EPA shall notify Valero in writing of the activities it must undertake to complete the requirements. Valero shall perform all activities described in EPA's notice in accordance with the specifications established therein, subject to Valero's right to invoke the dispute resolution provisions of Part XXIII.

B. Refinery Compliance Status Changes.

126. Commencing on the Date of Entry of the Consent Decree and continuing through termination, Valero shall not change the compliance status of the Paulsboro, Ardmore, Corpus Christi West, Three Rivers, Texas City, McKee, Wilmington, the Elective 6 BQ or Benicia refineries, and Tesoro shall not change the compliance status of the Golden Eagle Refinery, from the 6 BQ compliance option to the 2 Mg compliance option. If at any time from the Date of Entry of the Consent Decree through its termination, any Exempt Refinery is determined to have a TAB equal to or greater than 10 Mg/yr, Valero shall not utilize the 2 Mg compliance option. Valero or Tesoro, as applicable, shall consult with EPA and the appropriate Plaintiff-Intervener before making any change in compliance status not expressly prohibited by this Paragraph 126. Any such change must be undertaken in accordance with the regulatory provisions of the Benzene Waste NESHAP.

C. One-Time Review and Verification of Each Refinery's TAB and, as Applicable, Each Refinery's Compliance with the Appropriate Compliance Options.

127. On or before March 31, 2007, Valero shall complete a review and verification of the Refinery's TAB for each Elective 6 BQ Refinery. Valero shall implement all actions

necessary to ensure compliance with the 6 BQ compliance option at the Elective 6 BQ Refineries in accordance with Paragraph 125. Thereafter, such Elective 6 BQ Refineries shall be subject to and comply with the terms of this Part X applicable to refineries subject to the 6 BQ compliance option. The provisions of Paragraphs 128 and 129 shall not apply to the Elective 6 BQ Refineries.

128. Phase One of the Review and Verification Process. By no later than December 31, 2005, Valero or Tesoro, as applicable, shall complete a review and verification of each Refinery's TAB to determine compliance with the 2 Mg compliance option for the Corpus Christi East Refinery, 6 BQ compliance option for Benicia, Ardmore, Corpus Christi West, Three Rivers, Texas City, McKee, Wilmington, Paulsboro and Golden Eagle or to confirm that the TAB is less than 10 Mg/yr for the Exempt Refineries, as applicable. For each Refinery, the review and verification process shall include:

(a) an identification of each waste stream that is required to be included in the Refinery's TAB (e.g., slop oil, tank water draws, spent caustic, desalter rag layer dumps, desalter vessel process sampling points, other sample wastes, maintenance wastes, and turnaround wastes);

(b) a review and identification of the calculations and/or measurements used to determine the flows of each waste stream for the purpose of ensuring the accuracy of the annual waste quantity for each waste stream;

(c) an analysis of the benzene concentration in each waste stream, using previous analytical data, documented knowledge of the waste streams or new analytical testing data in accordance with 40 C.F.R. § 61.355(c)(2); and

(d.) an identification of whether or not the stream is controlled consistent with the requirements of Subpart FF.

129. By no later than thirty (30) days following the completion of Phase One of the review and verification process, Valero or Tesoro, as applicable, shall submit a Benzene Waste NESHAP Compliance Review and Verification Report ("BWN Compliance Review and Verification Report") that sets forth the results of Phase One as identified in (a) through (d) of Paragraph 128. At its option, Valero may submit one BWN Compliance Review and Verification Report that includes the results of all Refineries or may submit separate BWN Compliance Review and Verification Reports for each Refinery or any combination of refineries subject to this Consent Decree.

130. Phase Two of the Review and Verification Process. Based on EPA's review of the BWN Compliance Review and Verification Report(s), EPA may select up to twenty (20) waste streams at each Refinery for sampling for benzene concentration. Valero or Tesoro, as applicable, will conduct the required sampling and submit the results to EPA within ninety (90) days of receipt of EPA's request, unless EPA requests sampling from more than five (5) of Valero's Refineries, in which case Valero may stagger the sampling and submit the results according to the following schedule:

(a.) the sampling results for six refineries shall be submitted within 120 days of receipt of EPA's request; and

(b.) the sampling results for any remaining refineries shall be submitted within 210 days of EPA's request;

Notwithstanding the foregoing schedule, in the event that a stream for which EPA has required sampling is not available for sampling under normal operating conditions within a timeframe that would allow Valero or Tesoro, as applicable, to satisfy such schedule, then Valero or Tesoro, as applicable, shall submit sampling results for the subject refinery without the result for the unavailable stream in accordance with the foregoing schedule, and shall supplement the sampling report as soon as practicable after such sampling result becomes available under representative operating conditions.

131. Valero or Tesoro, as applicable, will use the results of this sampling under Paragraph 130 to recalculate the TAB and the uncontrolled benzene quantity and to amend the relevant BWN Compliance Review and Verification Report, as needed. To the extent that EPA requires Valero or Tesoro, as applicable, to sample a waste stream previously sampled, Valero or Tesoro, as applicable, may average the results of all sampling events occurring after January 1, 2001. Valero or Tesoro, as applicable, shall submit an amended BWN Compliance Review and Verification Report for the relevant Refinery, if necessary, within ninety (90) days following the date of the completion of the required Phase Two sampling, if Phase Two sampling is required by EPA.

D. Implementation of Corrective Actions.

132. Amended TAB Reports. If the results of the BWN Compliance Review and Verification Report(s) indicate(s) that a Refinery's most recently-filed TAB report does not accurately reflect the TAB calculation for the Refinery, Valero or Tesoro, as applicable, shall submit, by no later than sixty (60) days after completion of the BWN Compliance Review and Verification Report(s), an amended TAB report to the appropriate regulatory authority. The

BWN Compliance Review and Verification Report(s) shall be deemed an amended TAB report for purposes of Subpart FF reporting to EPA.

133. Exempt Refineries. If the results of the BWN Compliance Review and Verification Report demonstrate that any of the Exempt Refineries has a TAB of over 10Mg/yr, Valero shall submit to the appropriate EPA Region and to the appropriate Plaintiff-Intervener no later than 180 days after completion of the BWN Compliance Review and Verification Report, a plan that identifies with specificity the compliance strategy and schedule that Valero will implement to ensure that the Refinery complies with the 6 BQ compliance option as soon as practicable. If more than two Refineries are impacted, Valero shall be afforded an additional ninety (90) days per additional refinery, not to exceed an additional 270 days, to complete and submit the compliance strategy and schedule plans.

134. Corrective Action. If the results of the BWN Compliance Review and Verification Report(s) indicate that Valero or Tesoro, as applicable, is not in compliance with the 2 Mg compliance option at the Corpus Christi East Refinery or the 6 BQ compliance option at Ardmore, Benicia, Corpus Christi West, Three Rivers, Texas City, McKee, Wilmington, Paulsboro and/or Golden Eagle Refineries, then Valero or Tesoro, as applicable, shall submit EPA, to the appropriate EPA Region, and to the appropriate Plaintiff-Intervener, by no later than sixty (60) days after completion of the BWN Compliance Review and Verification Report(s), a plan that identifies with specificity the compliance strategy and schedule that Valero or Tesoro, as applicable, will implement to ensure that the subject Refinery complies with its applicable compliance option, or an alternative compliance option authorized under Subpart FF and Paragraph 126 as soon as practicable.

135. Review and Approval of Plans Any plans submitted pursuant to Paragraphs 133 and 134 shall be subject to the approval of, disapproval of, or a request for modification by EPA, which shall act after an opportunity for consultation with the appropriate Plaintiff-Intervener consistent with the Benzene Waste NESHAP. Within sixty (60) days after receiving any notification of disapproval or request for modification from EPA, Valero or Tesoro, as applicable, shall submit to EPA a revised plan that responds to all identified deficiencies. Upon receipt of approval from EPA, Valero or Tesoro, as applicable, shall commence implementation of the plan according to the schedule approved in the plan. Disputes arising under this Paragraph 135 shall be resolved in accordance with the dispute resolution provisions of this Consent Decree. Within sixty (60) days of completion of all requirements above, Valero or Tesoro, as applicable, shall certify to EPA and the appropriate Plaintiff-Intervener that each Refinery is in compliance with the Benzene Waste NESHAP.

E. Carbon Canisters.

136. For each of Valero's Refineries that is subject to the 6 BQ or 2 Mg compliance option control requirements of the Benzene NESHAP and for Tesoro's Golden Eagle Refinery, Valero or Tesoro, as applicable, shall comply with the requirements of this Section X.E at all locations at such Refineries where a carbon canister(s) is utilized as a control device under the Benzene Waste NESHAP.

137. From the Date of Entry of the Consent Decree through termination of this Part, neither Valero nor Tesoro shall use a single carbon canister for any new units or installations that require control pursuant to the Benzene Waste NESHAP at any Refineries subject to the 6 BQ or

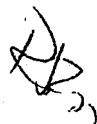

2 Mg compliance option, unless it is technically infeasible or unsafe to use a dual carbon canister system or except as provided for in Paragraph 138 for short term installations.

138. For existing carbon canister systems used to control emissions from installations that require control pursuant to the Benzene Waste NESHAP at the Corpus Christi East Refinery, Valero shall complete installation of primary and secondary carbon canisters and operate them in series, by no later than 270 days after the Date of Entry of the Consent Decree. For the 6 BQ Refineries, Valero or Tesoro, as applicable, shall complete installation of primary and secondary carbon canisters and operate them in series by no later than June 30, 2005. Notwithstanding any other provision of this Part X, Valero or Tesoro, as applicable, may operate single canisters for short-term operations such as with temporary storage tanks. For all canisters operated for short-term operations as part of a single canister system, "breakthrough" is defined for the purposes of this Decree as any reading of VOCs above background. Beginning no later than the Date of Entry of this Consent Decree, Valero and Tesoro shall monitor for breakthrough from a single carbon canister installation no less frequently than on a daily basis.

139. For locations where single canisters are utilized for short term operations, canisters will be replaced when breakthrough is determined within eight (8) hours for canisters with historical replacement intervals of two weeks or less or within twenty-four (24) hours for canisters with a historical replacement interval of more than two weeks. Single carbon canisters can be replaced with a dual system (in series) at any time, provided single canister monitoring is continued until the second canister is installed.

140. By no later than ninety (90) days following the Date of Entry, Valero shall submit to EPA a report concerning carbon canisters installed pursuant to Subpart FF at Valero's

Refineries and Tesoro shall submit to EPA a report concerning carbon canisters installed pursuant to Subpart FF at Tesoro's Golden Eagle Refinery. The report shall include the following information for each Refinery:

- (a) a list of all permanent locations within each Refinery where carbon canisters are installed;
- (b) the installation date of each secondary canister installed in accordance with Paragraph 138;
- (c) the date that each secondary canister installed in accordance with Paragraph 138 was put into operation;
- (d) the identity and location of each engineered carbon canister system, as hereinafter defined;
- (e) the capacity in pounds of carbon of each engineered carbon canister system; and
- (t) a list of and supporting justification for each instance in which a dual carbon canister system is not installed because of technical infeasibility or the creation of an unsafe condition at a location otherwise requiring a dual carbon canister system under Paragraph 137.

141. From the Date of Entry and through termination of the Consent Decree, "breakthrough" between the primary and secondary canister is defined as any reading equal to or greater than 100ppm VOCs or 5 ppm benzene. In the event that Valero or Tesoro elects to monitor for both VOCs and benzene pursuant to this provision, then "breakthrough" between the primary and secondary canister shall be defined only as a reading greater than 5 ppm benzene, provided that Valero or Tesoro, as applicable, satisfies the following conditions:

67 RJA

(a.) Valero or Tesoro, as applicable, shall collect and analyze the sample for benzene as soon as practical, and in no event later than 24 hours after obtaining the relevant VOC reading; and

(b.) Valero or Tesoro, as applicable, shall conduct monitoring for benzene breakthrough between the primary and secondary carbon canisters for the subject dual carbon canister system until such time as it replaces the relevant primary carbon canister with the secondary carbon canister pursuant to Paragraph 143 according to the following schedule: (i) where the design carbon replacement interval for the unit is less than or equal to 30 days, Valero or Tesoro, as applicable, shall monitor every operating weekday; (ii) where the design carbon replacement interval for the unit is 31 to 60 days, Valero or Tesoro, as appropriate shall monitor at least twice a week; (iii) where the design carbon replacement interval for the unit is greater than sixty (60) days, Valero or Tesoro, as applicable, shall monitor at least weekly.

142. By no later than seven (7) days after the Date of Entry of the Consent Decree (for existing dual canister systems), and by no later than seven (7) days after the installation of each new dual canister system, Valero and Tesoro shall start to monitor for breakthrough between the primary and secondary carbon canisters at times when the source is connected to the carbon canister, and during periods of normal operation in accordance with the frequency specified in 40 C.F.R. § 61.354(d) (but in no event less frequently than once per month), or alternatively at least once on each operating weekday.

143. Valero and Tesoro shall replace the original secondary carbon canister with a fresh carbon canister immediately when breakthrough between the primary and secondary canister is

detected. The original secondary carbon canister will become the new primary carbon canister and the fresh carbon canister will become the secondary canister.

(a.) For carbon canisters not qualifying as engineered carbon canister systems pursuant to this paragraph, "immediately" shall mean within twenty-four (24) hours; provided, however, that if breakthrough is determined on a Saturday, Sunday, or holiday, then Valero or Tesoro, as applicable, shall replace the original primary carbon canister by the end of the next regular work day if Valero or Tesoro, as applicable, begins monitoring the secondary canister at least once per operating day until the primary canister is replaced.

(b.) For engineered carbon canister systems, "immediately" shall mean not more than fourteen (14) days if Valero or Tesoro, as applicable, monitors the secondary canister at least once per operating day until the carbon in the primary canister is replaced and such monitoring of the secondary canister does not reveal "breakthrough", as defined in Paragraph 141. If breakthrough from the secondary canister is revealed, Valero or Tesoro, as applicable, shall replace the secondary carbon canister within twenty-four hours of securing such monitoring results. For purposes of this Paragraph 143, "engineered carbon canister systems" shall mean carbon systems with fixed vessels for which each vessel has a capacity of carbon in excess of 5000 pounds.

(c.) In lieu of replacing a primary or secondary carbon canister pursuant to the terms of this paragraph, Valero or Tesoro, as applicable, may elect to discontinue flow of benzene containing streams to the relevant carbon canister system until such system is replaced.

144. Valero shall maintain or otherwise provide for a reasonable supply of fresh carbon and carbon canisters at each of Valero's Refineries and Tesoro shall maintain or otherwise

provide for a reasonable supply of fresh carbon and carbon canisters at the Golden Eagle Refinery.

145. Records to demonstrate compliance with the requirements of this Section X.E shall be maintained in accordance with 40 C.F.R. § 61.3560(10).

F. Annual Program.

146. Valero shall establish an annual program of reviewing process information for each of Valero's Refineries and Tesoro shall establish an annual program of reviewing process information for the Golden Eagle Refinery, including but not limited to construction projects, to ensure that all new benzene waste streams are included in each Refinery's waste stream inventory. Valero or Tesoro may fulfill this requirement by incorporating new benzene waste stream review into its existing "management of change" program.

G. Laboratory Audits.

147. Valero or Tesoro, as applicable, shall conduct audits, or secure results of audits conducted by parties other than the laboratories, of all laboratories that perform analyses of benzene waste NESHAP samples collected at Valero's Refineries and Tesoro's Golden Eagle Refinery, respectively, to ensure that proper analytical and quality assurance/quality control procedures are followed.

148. By no later than one (1) year after the Date of Entry of the Consent Decree, Valero shall conduct audits, or secure results of audits conducted by parties other than the laboratories, of the laboratories used by half of Valero's Refineries and Tesoro shall conduct audits, or secure results of audits conducted by parties other than the laboratories, of the laboratories used at the Golden Eagle Refinery. Valero shall complete audits, or secure results of audits conducted by

parties other than the laboratories, of the laboratories used by the remaining half of Valero's Refineries within twenty-four (24) months of the Date of Entry of the Consent Decree. In addition, Valero and Tesoro shall audit any new laboratory, or secure results of audits conducted by parties other than the new laboratory, used for analyses of benzene waste NESHAP samples prior to use of the new laboratory by a Refinery subject to this Consent Decree.

149. If Valero or Tesoro has completed audits of laboratory in the one year period prior to the Date of Entry of the Consent Decree, additional audits of those laboratories pursuant to Paragraph 148 shall not be required.

150. During the life of this Consent Decree, Valero and Tesoro shall conduct subsequent laboratory audits, or secure results of audits conducted by parties other than the laboratories, as provided above, such that each laboratory serving each company's respective refinery/refineries is audited every two (2) years.

151. As stated above, Valero or Tesoro may retain third parties to conduct these audits or use audits conducted by others as its own, but the responsibility and obligation to ensure compliance with this Consent Decree and Subpart FF would remain with Valero or Tesoro, as applicable.

H. Benzene Spills.

152. Valero shall review all spills reportable under applicable federal and state standards that occur after the Date of Entry of this Consent Decree within each of Valero's Refineries and Tesoro shall review all spills reportable under applicable federal and state standards that occur after the Date of Entry of this Consent Decree within Tesoro's Golden Eagle Refinery to determine if aqueous benzene waste was generated. To the extent required by the Benzene

Waste NESHAP regulations and not already in the TAB, Valero or Tesoro, as applicable, shall include benzene generated by such spills in the TAB. To the extent required by the Benzene Waste NESHAP regulations, Valero and Tesoro, as applicable, shall include benzene generated by such spills in the uncontrolled benzene quantity calculations for each Refinery.

I. Training.

153. By no later than one hundred twenty (120) days from the Date of Entry of the Consent Decree, Valero shall develop for Valero's Refineries and Tesoro shall develop for Tesoro's Golden Eagle Refinery an annual (i.e. once each calendar year) training program for employees asked to draw benzene waste samples.

154. For the Corpus Christi East, Corpus Christi West, Three Rivers, Texas City, McKee, Wilmington, Ardmore, Paulsboro and Benicia Refineries, no later than one hundred eighty (180) days from the Date of Entry of the Consent Decree, Valero shall complete the development of standard operating procedures for all control equipment used to comply with the Benzene Waste NESHAP. For Tesoro's Golden Eagle Refinery, by no later than one hundred eighty (180) days from the Date of Entry of the Consent Decree, Tesoro shall complete the development of standard operating procedures for all control equipment used to comply with the Benzene Waste NESHAP. By no later than two hundred seventy (270) days thereafter, Valero and Tesoro, as applicable, shall complete an initial training program regarding these procedures for all operators assigned to this equipment. Comparable training shall also be provided to any persons who subsequently become operators, prior to their assumption of this duty. Until termination of this Decree, "refresher" training in these procedures shall be performed on at least a three year cycle.

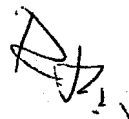

155. Exempt Refineries shall comply with the provisions of Paragraph 154 if and when such Refinery's TAB reaches 10 Mgiyr. Valero shall propose a schedule for training at the same time that Valero proposes a plan, pursuant to Paragraph 133, that identifies the compliance strategy and schedule that Valero will implement to bring such Refinery into compliance with the 6 BQ compliance option.

156. The Elective 6 BQ Refineries shall comply with the provisions of Paragraph 154; provided however, that the development of the standard operating procedures and the initial training shall be completed by no later than December 1, 2006.

157. As part of Valero's and Tesoro's training programs, Valero and Tesoro must require any contractor hired to perform all or part of the requirements of this Part X to properly train its employees to implement the relevant provisions of this Part X.

J. Waste/Slop/Off-Spec Oil Management.

158. Valero has developed and EPA has approved representative schematics, attached as part of the end-of-line ("EOL") in Appendix G, reflecting the movements of waste/slop/off-spec oil streams within two refineries. For each of the other Valero Refineries subject to this Consent Decree and for Tesoro's Golden Eagle Refinery, Valero or Tesoro, as applicable, shall develop a similar schematic reflecting the movements of waste/slop/off-spec oil streams within each Refinery and shall provide this schematic to EPA on or before June 30, 2005. Valero and Tesoro, as applicable, will then certify to the best of their knowledge following reasonable inquiry, that these schematics accurately depict the waste management units (including sewers) located at Valero's Refineries and Tesoro's Golden Eagle Refinery upon the date of submittal under this paragraph that handle, store and transfer waste/slop/off-spec oil

streams; identify the control status of each waste management unit; and show how such oil is transferred within each Refinery. To the extent that Valero or Tesoro, as applicable, and EPA determine that any change to a Refinery subject to this Consent Decree necessitates a revision to a schematic, then Valero or Tesoro, as applicable, shall update such schematic.

159. Organic Benzene Waste Streams. As of the Date of Entry of this Consent Decree for the Ardmore, Corpus Christi West, McKee Wilmington, Three Rivers, Texas City, Corpus Christi East, Paulsboro and Benicia Refineries, as of December 1, 2006 for each Elective 6 BQ Refinery, or in accordance with any compliance strategy approved by EPA pursuant to Paragraph 135, Valero shall ensure that all waste management units handling "organic" benzene wastes, as defined in Subpart FF, shall meet any control standards applicable to such units under Subpart FF. As of the Date of Entry of this Consent Decree, Tesoro shall ensure that all waste management units at the Golden Eagle Refinery handling "organic" benzene wastes, as defined in Subpart FF, shall meet any control standards applicable to such units under Subpart FF.

160. Aqueous Benzene Waste Streams. Except as otherwise provided by Subpart FF, for purposes of calculating the TAB at each of Valero's Refineries and Tesoro's Golden Eagle Refinery pursuant to the requirements of 40 C.F.R. § 61.342(a), Valero or Tesoro, as applicable, shall include all waste/slop/off-spec oil streams that become "aqueous" until such streams are recycled to a process or put into a process feed tank (unless the tank is used primarily for the storage of wastes). For purposes of complying with the 2 Mg or 6 BQ compliance option, to the extent required by Subpart FF, all waste management units handling aqueous benzene waste streams shall either meet the applicable control standards of Subpart FF or shall have their uncontrolled benzene quantity count toward the applicable 2 or 6 megagram limit.

161. Recordkeeping. For each of Valero's Refineries, Valero shall maintain records quantifying waste/slop/off-spec oil movements for all benzene waste streams. For Tesoro's Golden Eagle Refinery, Tesoro shall maintain records quantifying waste/slop/off-spec oil movements for all benzene waste streams.

162. Disputes under this Section X,J shall be resolved in accordance with the dispute resolution provisions of this Consent Decree.

K. **End of Line Sampling**

163. The provisions of this Section X,K shall apply to Valero's Refineries other than the Elective 6 BQ Refineries from the Date of Entry through termination of this Part, and shall apply to the Elective 6 BQ Refineries from December 1, 2006 through termination of this Part. The provisions of this Section X.K shall apply to Tesoro's Golden Eagle Refinery from the Date of Entry through termination of this Part.

164. Valero has developed and EPA has approved representative EOL Plans, attached within Appendix G, designed to determine the benzene quantity in uncontrolled waste streams, including sampling locations and methods for flow calculations to be used in quarterly EOL benzene determination. By no later than June 30, 2005, Valero for each of the Valero Refineries not governed by the EOL Plans within Appendix G and Tesoro for its Golden Eagle Refinery, shall develop and submit to EPA similar EOL plans. EPA shall approve the EOL Plan for each Valero Refinery and for Tesoro's Golden Eagle Refinery provided such plans are consistent with the representative EOL Plans attached within Appendix G.

165. Commencing with the third calendar quarter of 2005, Valero shall conduct quarterly EOL sampling for benzene quantities in uncontrolled waste streams at Valero's Refineries and

Tesoro shall conduct quarterly EOL sampling for benzene quantities in uncontrolled waste streams at Tesoro's Golden Eagle Refinery according to each proposed and/or approved EOL Plan. Quarterly EOL sampling for the Texas City and Krotz Springs refineries shall commence during the first full quarter after Entry of this Decree but in no case later than the third calendar quarter of 2005.

166. If changes in processes, operations, or other factors cause the approved sampling locations and approved methods for determining flow calculations to no longer provide an accurate measure of a Refinery's EOL benzene quantity, Valero or Tesoro, as applicable, shall submit a revised EOL Plan to EPA for approval.

167. Valero and Tesoro shall use all sampling results and approved flow calculation methods under the approved sampling plans referenced in Paragraph 164 to calculate a quarterly and estimate a calendar year value for each of Valero's Refineries and Tesoro's Golden Eagle Refinery, respectively. If the quarterly calculation for a refinery made pursuant to this paragraph exceeds: (a) 2.5 Mg for a refinery with TAB historically less than 10 Mg/yr, (b) 0.5 Mg for a refinery complying with the 2 Mg compliance option, or (c) 1.5 Mg for a refinery complying with the 6 BQ compliance option, but Valero or Tesoro, as applicable, estimates that the annual benzene quantity for such refinery will remain below the referenced annual quantity, then Valero or Tesoro, as applicable, shall include within its next report under Paragraph 176 or 178 comments justifying why, notwithstanding the quarterly calculation, Valero or Tesoro, as applicable, estimates that the annual benzene quantity will not exceed the applicable level listed above.

168. If any estimated annual benzene calculation for any facility made pursuant to the proceeding paragraph exceeds: (a) 10Mg for an Exempt Refinery, (b) 2 Mg for a refinery complying with the 2 Mg compliance option or (c) 6 Mg for a refinery complying with the 6 BQ compliance option, then Valero or Tesoro, as applicable, shall prepare for each such refinery a written summary and schedule of the activities planned to minimize benzene waste at such refinery to ensure that it complies with the Benzene Waste Operations NESHAP. (The estimated annual values in and of themselves, are not the basis for penalties and are not deemed to be instances of non-compliance for purpose of this Consent Decree.) The summary and schedule are due no later than sixty (60) days after the of the quarter in which the estimated annual value exceeds the applicable quantity (the "TAB Study and Compliance Review").

169. Notwithstanding any other provision of this Part X, for each Refinery that has a TAB less than 10Mg/yr, Valero or Tesoro, as applicable, may exclude or subtract, as appropriate, from its EOL benzene determinations any quantity of benzene in wastes that would otherwise be excluded under Subpart FF from the calculation of the TAB, such as a stream generated by remediation activities conducted at the Refinery.

170. Valero shall maintain records supporting its quarterly calculations of EOL quantities, including the methodology and data used to identify and calculate flow until termination of the obligations of this Part.

L. Miscellaneous Measures.

171. For Valero's Refineries that have a TAB greater than 10Mg/yr and for Tesoro's Golden Eagle Refinery, Valero and Tesoro, as applicable, shall manage all groundwater remediation conveyance systems in accordance with, and to the extent required by, the Benzene

Waste NESHAP, 40C.F.R. § 61.342. In accordance with 40C.F.R. § 61.342, Valero or Tesoro, as applicable, may exclude from the calculation of a Refinery's TAB the benzene concentration in any waste generated by remediation activities conducted at such Refinery.

172. The provisions of this Paragraph 172 shall apply to: (a) the Ardmore, Corpus Christi West, Wilmington, McKee, Three Rivers, Texas City, Paulsboro, Benicia, Golden Eagle and Corpus Christi East Refineries within the first calendar quarter commencing after the Date of Entry of the Consent Decree through termination of the Consent Decree; (b) each Elective 6 BQ Refinery by no later than December 1, 2006, through termination of the Consent Decree; and (c) an Exempt Refinery, if the respective TAB at such Refinery reaches 10 Mg/yr, from such time as a compliance strategy is completed, through termination of the Consent Decree. For Valero's Refineries, Valero shall, and for Tesoro's Golden Eagle Refinery, Tesoro shall:

- (a.) Conduct monthly visual inspections of all water traps within the Refinery's individual drain systems that are controlled under the Benzene Waste NESHAP;
- (b.) Identify and mark all area drains that are segregated stormwater drains;
- (c.) Where installed pursuant to Subpart FF, visually monitor all conservation vents or indicators on process sewers for detectable leaks on a weekly basis and reset any vents where leaks are detected. After two (2) years of weekly inspections, and based upon an evaluation of the recorded results, Valero or Tesoro, as applicable, may submit a request to the appropriate EPA Region to modify the frequency of the inspections. EPA shall not unreasonably withhold its consent. Nothing in this subparagraph shall require Valero or Tesoro to monitor conservation vents on fixed rooftanks.

(d.) Conduct quarterly monitoring, in accordance with the "no detectable emissions" provision in 40 C.F.R. § 61.347, of oil-water separators controlled in accordance with 40 C.F.R. § 61.347.

173. The Texas City Refinery is currently subject to the control requirements of the Benzene Waste NESHAP. The Marathon Texas City Refinery is also currently subject to the control requirement of the Benzene Waste NESHAP. The Valero Texas City Refinery removes hydrogen sulfide from the sourwater received from the Marathon Refinery to provide a feedstock for Valero's sulfur recovery units. While in its possession, Valero shall manage this sourwater in a totally closed system prior to its use as a feedstock. The resulting wastewater after sulfur recovery is discharged to Valero's wastewater treatment plant. EPA, Texas and Valero agree that Valero is not required to include the benzene content of this Marathon sour water stream in the calculation of the TAB for Valero's Texas City Refinery. However, the benzene content of all wastewater discharged from the sourwater strippers at Valero's Texas City Refinery, including those sour water strippers used to process the Marathon sour water stream, shall be included in the calculation of the TAB for Valero's Texas City Refinery to the extent required by the Benzene Waste NESHAP.

174. Notwithstanding any other provision in this Consent Decree or its required sampling, Valero and Tesoro, as applicable, shall account for and include in the TAB all slop oil recovered from its oil/water separators or sewer systems until recycled or put into a feed tank in accordance with, and only to the extent required by 40 C.F.R. § 61.342(a). In no event shall the benzene content in slop oil be counted more than once towards a facility's TAB calculation.

Df
32

M. Recordkeeping and Reporting Requirements for this Part

175. In addition to the Reports Required under 40 C.F.R. § 61.357. At the times specified in the applicable provisions of this part, Valero shall submit for Valero's Refineries and Tesoro shall submit for Tesoro's Golden Eagle Refinery the following reports to EPA, to the applicable EPA Region, and to the applicable signatory state agency:

- (a.) BWN Compliance Review and Verification Report (§129), as amended, if necessary (§131);
- (b.) Amended TAB Report, if necessary ('132);
- (c.) Plan for any of the Exempt Refineries to come into compliance with the 6 BQ compliance option upon discovering that its TAB equals or exceeds 10Mg/yr through the BWN Compliance Review and Verification Report ('133);
- (d.) Planes) to comply with Subpart FF, if the BWN Compliance Review and Verification Reports indicate non-compliance ('134);
- (e.) Report concerning carbon canister systems ('140);
- (f.) TAB Study and Compliance Review, if necessary ('168).

176. In Conjunction with the Reports Required under 40 C.F.R. § 61.357 For each Refinery for which Valero or Tesoro, as applicable, is required, pursuant to 40 C.F.R. §§ 61.357(d)(6) and (7), to submit quarterly reports ("Section 61.357 Reports"), Valero or Tesoro, as applicable, shall include the following additional information in the subject Section 61.357 Reports for such Refinery:

- (i.) Laboratory Audits. Once laboratory audits are required to have been conducted pursuant to the provisions of Section X'G; Valero or Tesoro, as applicable, shall

identify, in each Section 61.357 Report submitted thereafter until termination of this Consent Decree, all laboratory audits completed for such Refinery pursuant to the provisions of Section X.G during the calendar quarter for which the quarterly report is due. Valero or Tesoro, as applicable, shall include the identification of each laboratory audited, a description of the methods used in the audit, and a summary of the results of the audit.

- (ii.) Training. Once Valero or Tesoro is required to have conducted training at its Refinery pursuant to Section XI., Valero or Tesoro, as applicable, shall describe, in each Section 61.357 Report submitted thereafter until termination of this Consent Decree, the measures that it took to comply with the training provisions of Section X.I for such Refinery, starting from the Date of Entry of the Consent Decree;
- (iii.) EOL Sampling Results. Once EOL sampling is required under Section x.K, Valero or Tesoro, as applicable, shall report the results of the quarterly EOL sampling undertaken at such Refinery pursuant to Section X.K for the calendar quarter. The report shall include a list of all waste streams sampled at such Refinery, the results of the benzene analysis for each sample, the computation of the EOL benzene quantity for the quarter and any other related information required by any plan approved for such Refinery pursuant to Paragraph 164.

177. In lieu of Section 61.357 Reports, Valero shall submit information for the Elective 6 BQ Refineries required by Paragraph 176 in the Progress Report required by Part XVI. After completion of the work required to ensure that the Elective 6 BQ Refineries comply with the 6



BQ compliance option, those refineries may elect to submit the information described in Paragraphs 176 in their Section 61.357 Reports.

178. For each Refinery for which Valero determines a TAB level of less than 10 mg/yr (and for which Valero is not required, to submit a Section 61.357 Report), Valero shall submit a progress report as part of the report required by Part XVI. For each semi-annual period, Valero shall submit for such Refinery the information described in Paragraphs 176(i)-(ii), and the following information:

- (i) The results of the quarterly EOL sampling undertaken pursuant to Paragraphs 164-167.
- (ii) A list of all waste streams sampled, the results of the benzene analysis for each sample, and the computation of the EOL benzene quantity for the respective quarters:
- (iii) An identification, for each Refinery, of whether the quarterly benzene quantity equals or exceeds 2.5 Mg/yr and whether the projected calendar year benzene quantity equals or exceeds 10 Mg/yr. If either condition is met, Valero shall include in the Progress Report a plan or determination, if required pursuant to Paragraphs 167 and 168.

179. If, during the life of this Consent Decree, the TAB at any of the Exempt Refineries exceeds 10 Mg/yr and the Refinery completes the installation of the measures necessary to comply with the 6 BQ compliance option, the Refinery may elect to submit the information required in Paragraph 176 through Section 61.357 Reports instead of through separate progress reports.

180. Reserved.

N. Agencies to Receive Reports, Plans and Certifications Required in the paragraph; Number of Copies.

181. Unless otherwise specified in this Part, Valero and Tesoro shall submit all reports, plans and certifications required to be submitted under this Part X to EPA, the appropriate EPA Region and the applicable Plaintiff-Intervener. For each submission, Valero and Tesoro shall submit two copies to EPA, two copies to the appropriate EPA Region and two copies to the appropriate Plaintiff-Intervener. By agreement between Valero and each of the offices that are to receive the materials in this Part X, Valero may submit the materials electronically.

XI. LEAK DETECTION AND REPAIR ("LDAR") PROGRAM ENHANCEMENTS

Program Summary: Valero shall undertake at each Valero Refinery subject to this Consent Decree, and Tesoro shall undertake at the Golden Eagle Refinery, the following measures to enhance each Refinery's LDAR program and minimize or eliminate fugitive emissions from valves and pumps in light liquid and/or in gas/vapor service.

A. Introduction

182. In order to minimize or eliminate fugitive emissions of volatile organic compounds ("VOCs"), benzene, volatile hazardous air pollutants ("VHAPs"), and organic hazardous air pollutants ("HAPs") from valves and pumps in light liquid and/or in gas/vapor service, Valero shall undertake at each of Valero's Refineries and Tesoro shall undertake at Tesoro's Golden Eagle Refinery the enhancements of this Part XI to each Refinery's LDAR program under Title 40 of the Code of Federal Regulations, Part 60, Subparts VV and GGG; Part 61, Subparts J and V; Part 63, Subparts F, H, and CC; and applicable state and local LDAR requirements that are federally enforceable or implemented by participating Plaintiff-Interveners (collectively, the

"LDAR Regulations"). The terms "in light liquid service" and "in gas/vapor service" shall have the definitions set forth in the applicable provisions of the LDAR Regulations.

183. Valero has developed and implemented an enhanced LDAR program at its Benicia Refinery. Tesoro has developed and implemented an enhanced LDAR program at its Golden Eagle Refinery. In lieu of complying with the requirements of this Part XI and after notice to EPA, Valero may elect to continue implementation of the existing LDAR program at the Benicia Refinery, and Tesoro may continue implementation of the existing LDAR program at the Golden Eagle Refinery, with the addition of the following requirements under this Part: Training (Section XI.C), LDAR Audits (Section XI.D), Implementation of Actions Necessary to Correct Non-Compliance (Section XI.E), Electronic Monitoring, Storing and Reporting of LDAR Data (Section XI.K), *QA/QC* of LDAR Data (Section XI.L), Delay of Repair (Section XI.Q) and the reporting requirements under Section XI.R associated with these requirements.

184. For purposes of this Part XI, "Equipment" shall mean pumps and valves in light liquid or gaseous service at the refineries subject to this Consent Decree, except for those pumps and valves exempt from standard monitoring frequencies under applicable LDAR Regulations.

B. Written Refinery-Wide LDAR Program.

185. By no later than March 31, 2006, Valero and Tesoro, as applicable, shall develop and maintain, for each Refinery subject to this Consent Decree, a written, Refinery-wide program for compliance by such Refinery with applicable LDAR Regulations. Until termination of this Decree, Valero and Tesoro, as applicable, shall implement these programs at each Refinery subject to this Consent Decree on a Refinery-wide basis, and shall update each



Refinery's program as necessary to ensure continuing compliance. Each Refinery-wide program shall include:

- (1.) An overall, Refinery-wide leak rate goal that will be a target for achievement on a process-unit-by-process-unit basis. For purposes of this provision, the overall Refinery-wide leak rate goal shall constitute a tool for implementation of the Refinery-wide program, but shall not be enforceable or subject to stipulated penalties under Part XX.
- (2.) Identification of all Equipment that has the potential to leak VOCs, HAPs, VHAPs, and benzene within process units that are owned and maintained by each Refinery.
- (3.) Procedures for identifying leaking Equipment within process units that are owned and maintained by each Refinery;
- (4.) Procedures for repairing and keeping track of leaking Equipment;
- (5.) Procedures for identifying and including in the LDAR program new Equipment;
and
- (6.) A process for evaluating new and replacement Equipment to promote consideration and installation of equipment that will minimize leaks and/or eliminate chronic leakers.

C. Training.

186. By no later than March 31, 2006, Valero or Tesoro, as applicable, shall implement the following training programs at each of its Refineries subject to this Consent Decree:

- (1.) For personnel newly-assigned to LDAR responsibilities, require LDAR training prior to each employee beginning such work;
- (2.) For all personnel with assigned LDAR responsibilities, provide and require completion of annual LDAR training; and
- (3.) For all other Refinery operations and maintenance personnel (including contract personnel), provide and commence implementation of an initial training program, with completion within six (6) months thereafter, that includes instruction on aspects of LDAR if and to the extent that aspects of LDAR are relevant to the person's duties.
- (4.) Until termination of this Decree, perform "refresher" training in LDAR on a three year cycle.

D. LDAR Audits.

187. Valero shall undertake at each of Valero's Refineries and Tesoro shall undertake at the Golden Eagle Refinery the Refinery-wide audits set forth in paragraphs 188 and 189, to help ensure each Refinery's compliance with all applicable LDAR requirements. Valero's and Tesoro's LDAR audits shall include comparative monitoring of valves and pumps, records review to ensure monitoring and repairs for valves and pumps were completed as required, tagging review, data management review, and observation of the LDAR technicians' calibration and monitoring techniques.

188. Third-Party Audits. Valero and Tesoro, as applicable, shall conduct a third-party audit of each Refinery's LDAR program at least once every four years. For purposes of this requirement, "third party" may include a qualified contractor, consultant, industry group, or trade

association. The first third-party audit for half of Valero's Refineries and for Tesoro's Golden Eagle Refinery shall be completed no later than one year from the Date of Entry of the Consent Decree, and shall include at least the Paulsboro, Corpus Christi East and West, and Denver Refineries. The audits of the remaining half of Valero's Refineries shall be completed within two years from the Date of Entry of the Consent Decree. During the period between the Date of Entry and the date of the first audit for each refinery under this Section, Valero shall make reasonable efforts to ensure compliance with the requirements of this decree and all applicable LDAR regulations.

189. Internal Audits. Valero shall conduct internal audits of each of Valero's Refineries' LDAR programs by sending personnel familiar with the LDAR program and its requirements from one or more of Valero's Refineries or locations to audit another Valero Refinery. Valero shall complete the first round of these internal LDAR audits by no later than two years from the date of completion of the first round of third-party audits required in Paragraph 188. Tesoro shall conduct an internal audit of the Golden Eagle Refinery no later than two years from the date of completion of the first round of third-party audits required in Paragraph 188. Internal audits of each Refinery shall be held every four years thereafter for the life of this Consent Decree.

190. Frequency. To ensure that an audit at each Refinery subject to this Consent Decree occurs every two years, third-party and internal audits shall be separated by approximately two years after the initial Third Party Audit.

191. Alternative. As an alternative to the internal audits required by Paragraph 189, Valero or Tesoro may elect to retain third-parties to undertake these audits, provided that an audit of each Refinery occurs every two (2) years.

E. Implementation of Actions Necessary to Correct Non-Compliance.

192. If the results of any of the audits conducted pursuant to Section XI.D at any of Valero's Refineries or at Tesoro's Golden Eagle Refinery identify any areas of non-compliance with the LDAR Regulations, Valero or Tesoro, as applicable, shall implement, as soon as practicable, all appropriate steps necessary to correct the area(s) of non-compliance, and to prevent, to the extent practicable, a recurrence of the cause(s) of the non-compliance. In the Semi-Annual LDAR Report submitted pursuant to the provisions of Section XI.R covering the period when an audit was conducted, Valero or Tesoro, as applicable, shall certify to EPA that the audit has been completed and that the refinery is in compliance or on a compliance schedule.

F. Retention of Audit Reports.

193. Until termination of the Consent Decree, Valero and Tesoro shall retain the audit reports generated pursuant to Section XI.D and shall maintain a written record of the corrective actions taken at each of its Refineries in response to any deficiencies identified in any audits. In the Semi-Annual LDAR Report submitted pursuant to the provisions of Section XI.R covering the period when an audit was conducted pursuant to Section XI.D, Valero and Tesoro, as applicable, shall submit the audit reports and corrective action records for audits performed and actions taken during the previous semi-annual period.

Dj
3,

G. Internal Leak Definition for Valves and Pumps.

194. Valero shall utilize the following internal leak definitions for Equipment covered by an applicable LDAR program at Valero's Refineries, and Tesoro shall utilize the following internal leak definitions for Equipment covered by an applicable LDAR program at Tesoro's Golden Eagle Refinery, unless a lower leak definition is established for the relevant Refinery under applicable permit(s) or applicable state LDAR Regulations.

195. Leak Definition for Valves. An internal leak definition of 500 ppm VOCs for refinery valves qualifying as Equipment shall be utilized at the following Refineries by the dates specified: all valves at the Wilmington, Houston, and Texas City Refineries within six (6) months of the Date of Entry; one-half of the valves at the Corpus Christi West Refinery within six (6) months of the Date of Entry; and three-quarters of all valves at the Corpus Christi East Refinery within one (1) year of the Date of Entry of this Consent Decree. All remaining valves qualifying as Equipment at these refineries and the other refineries subject to this decree shall be monitored at an internal leak definition of 500 ppm VOCs by no later than March 31, 2007.

196. Leak Definition for Pumps. An internal leak definition of 2000 ppm for refinery pumps qualifying as Equipment shall be utilized at the following Refineries by the dates specified: all pumps at the Wilmington and Texas City Refineries within six (6) months of the Date of Entry; one-quarter of the pumps at the Houston Refinery within six (6) months of the Date of Entry; one-half of the pumps at the Corpus Christi West Refinery within six (6) months of the Date of Entry; and one-half of the pumps at the Corpus Christi East Refinery within one (1) year of the Date of Entry of this Consent Decree. All remaining pumps qualifying as

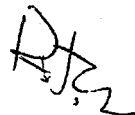

Equipment at these refineries and the other refineries subject to this decree shall be monitored at an internal leak definition of 2000 ppm VOCs by no later than March 31, 2007.

H. Reporting, Recording, Tracking, Repairing and Remonitoring Leaks of Valves and Pumps Based on the Internal Leak Definitions.

197. Reporting. For regulatory reporting purposes, Valero and Tesoro may continue to report leak rates in valves and pumps against the applicable regulatory leak definition, or may use the lower, internal leak definitions specified in Paragraphs 195 and/or 196.

198. Recording, Tracking, Repairing and Remonitoring Leaks. Valero and Tesoro shall record, track, repair and remonitor all leaks in excess of the internal leak definitions of Paragraphs 195 and 196 (at such time as those definitions become applicable) in accordance with applicable provisions of the LDAR Regulations, except that Valero and Tesoro shall have five (5) days to make an initial attempt at repair and thirty (30) days either to make final repairs and remonitor leaks that are greater than the internal leak definitions but less than the applicable regulatory leak definitions or to place the valve on the delay of repair list according to Section XLQ.

I. Initial Attempt at Repair on Valves.

199. Beginning no later than ninety (90) days after the Date of Entry of this Consent Decree, Valero or Tesoro, as applicable, shall make an "initial attempt" at repair on any valve qualifying as Equipment under Paragraph 184 that has a reading greater than 200 ppm of VOCs, for the life of the Consent Decree, excluding control valves, orbit valves and other valves that LDAR personnel are not authorized to repair. Valero, Tesoro or either company's designated contractor, as applicable, shall make this "initial attempt" and remonitor such valves within five

Handwritten signature or initials, possibly "DAW", in black ink.

(5) calendar days of identification. Unless the remonitored leak rate is greater than the applicable leak definition, no further action will be necessary.

J. LDAR Monitoring Frequency.

200. Pumps. When the lower leak definition for pumps becomes applicable pursuant to Paragraph 196, Valero or Tesoro, as applicable, shall monitor pumps qualifying as Equipment at the lower leak definition on a monthly basis.

201. Valves. When the lower leak definition for valves becomes applicable pursuant to Paragraph 195, Valero and Tesoro shall monitor valves qualifying as Equipment in accordance with one of the following options on a process unit-by-process unit basis:

(a). Quarterly monitoring with no ability to skip periods. This option cannot be chosen for process units subject to the HON or the modified-HON option in the Refinery MACT; or

(b) Sustainable skip period program (see attached Appendix I). Previous process unit monitoring results may be used to determine the initial skip period interval provided that each valve has been monitored using the 500 ppm leak definition. Process units monitored in the skip period alternative method may not revert to quarterly monitoring if the most recent monitoring period demonstrates that more than two percent of the valves were found leaking under the internal leak definition.

202. Reserved

203. For process units complying with the sustainable skip period program set forth in Paragraph 201 (b), EPA or the relevant state Intervener agency may require Valero or Tesoro, as applicable, to implement more frequent monitoring of valves qualifying as Equipment, in accordance with the monitoring frequencies specified in the skip period provisions identified in

Appendix I, if the leak rate determined during an EPA or relevant Plaintiff-Intervener inspection demonstrates that more frequent monitoring is appropriate. In evaluating whether the leak rate demonstrates that more frequent monitoring of valves is appropriate, EPA or the relevant Plaintiff-Intervener, as applicable, will determine the leak rate utilizing data generated in accordance with 40 C.F.R. Part 60, EPA Reference Test Method 21, and based on the total number of valves in the process unit, rather than the total number of valves monitored during the inspection.

204. Valero and Tesoro shall have the option of monitoring affected valves and pumps within process units after completing a documented maintenance, startup or shutdown activity without having the results of the monitoring count as a scheduled monitoring activity, provided that the company monitors according to the following schedule:

- (a.) Event involving 1,000 or fewer affected valves and pumps - monitor within one (1) week of the documented maintenance, startup or shutdown activity;
- (b.) Event involving greater than 1,000 but fewer than 5,000 affected valves and pumps - monitor within two (2) weeks of the documented maintenance, startup or shutdown activity; and
- (c.) Event involving greater than 5,000 affected valves and pumps - monitor within four (4) weeks of the documented maintenance, startup or shutdown activity.

K. Electronic Monitoring, Storing, and Reporting of LDAR Data.

205. Electronic Storing and Reporting of LDAR Data. For each of Valero's Refineries, Valero has and will continue to maintain an electronic database for storing and reporting LDAR data. Within one year of the Date of Entry, Tesoro shall commence use of an electronic database for storing and reporting LDAR data.

206. Electronic Data Collection During LDM Monitoring. By no later than March 31, 2006, Valero and Tesoro shall use dataloggers and/or electronic data collection devices during all LDAR monitoring required by this decree Valero and Tesoro, or third party contractor(s) retained by either, shall use their best efforts to transfer, on a daily basis, electronic data from electronic datalogging devices to the electronic database required pursuant to Paragraph 205. For all monitoring events in which an electronic data collection device is used, the collected monitoring data shall include a time and date stamp, operator identification, and instrument identification. Valero and Tesoro may use paper logs where necessary or more feasible (e.g., small rounds, remonitoring, or when dataloggers are not available or broken), and shall record the identification of the technician undertaking the monitoring, the date, time, and the identification of the monitoring equipment. Valero and Tesoro shall transfer any manually recorded monitoring data to the electronic database within seven (7) days of monitoring.

L. QAIOC of LDAR Data.

207. By no later than ninety (90) days after the Date of Entry of this Consent Decree, Valero and Tesoro, or third party contractor(s) retained by either, shall develop and implement a procedure to ensure a quality assurance/quality control ("*QAIOC*") review of all data generated by LDAR monitoring technicians. This *QAIOC* procedure shall include procedures for:

- (1.) Monitoring technician(s) reviewing the monitoring data daily;
- (2.) Quarterly performing a *QA/QC* review of Valero's, Tesoro's and any third party contractor's monitoring data which shall include, but not be limited to: number of components monitored per technician, time between monitoring events, and abnormal datapatterns.

M. LDAR Personnel.

208. By no later than the Date of Entry of the Consent Decree, Valero shall for Valero's Refineries, and Tesoro shall for Tesoro's Golden Eagle Refinery, establish a program that will hold LDAR personnel accountable for LDAR performance at each Refinery. Valero and Tesoro, as applicable, shall maintain a position within each Refinery with responsibility for LDAR management and with the authority to implement improvements.

N. Adding New Valves and Pumps.

209. By no later than one (1) year from the Date of Entry, Valero and Tesoro, as applicable, shall establish a tracking program for maintenance records (e.g., a Management of Change program) to ensure that valves and pumps qualifying as Equipment added to each Refinery during maintenance and construction are integrated into the LDAR program.

O. Calibration/Calibration Drift Assessment.

210. Calibration. Valero and Tesoro shall conduct all calibrations of LDAR monitoring equipment using methane as the calibration gas, in accordance with 40 C.F.R. Part 60, EPA Reference Test Method 21.

211. Calibration Drift Assessment. Beginning no later than sixty (60) days from the Date of Entry of this Consent Decree, Valero and Tesoro shall conduct calibration drift



assessments of LDAR monitoring equipment at the end of each monitoring shift, at a minimum. Valero and Tesoro shall conduct the calibration drift assessment using, at a minimum, a 500 ppm calibration gas. If any calibration drift assessment after the initial calibration shows a negative drift of more than 10% from the previous calibration, Valero or Tesoro, as applicable, shall remonitor all valves at such Refinery qualifying as Equipment that were monitored since the last calibration and that had a reading greater than 100 ppm and all pumps at such Refinery qualifying as Equipment that were monitored since the last calibration and that had a reading greater than 500 ppm.

P. Chronic Leakers.

212. Valero shall replace, repack, or perform similarly effective repairs on chronically leaking, non-control valves during the next process unit turnaround after identification. A component shall be classified as a "chronic leaker" under this paragraph if it leaks above 10,000 ppm twice in any consecutive four quarters, unless the component had not leaked in the twelve (12) consecutive quarters immediately prior to the relevant process unit turnaround.

Q. Delay of Repair.

213. Beginning no later than sixty (60) days from the Date of Entry of the Consent Decree, for any valves or pumps qualifying as Equipment for which Valero or Tesoro, as applicable, is allowed under the applicable LDAR Regulations to place on the "delay of repair" list, Valero or Tesoro, as applicable, shall satisfy the following requirements. Nothing in this provision is intended to limit Valero's or Tesoro's ability to isolate a valve or pump rather than placing it on the "delay of repair" list, to the extent authorized under applicable LDAR Regulations.

(a). For all valves or pumps:

(1.) Require sign-off by the unit supervisor that the valve or pump is technically infeasible to repair without a process unit shutdown, to the extent that the valve or pump is being placed on the "delay of repair" list for that reason; and

(2.) Include valves and pumps that are placed on the "delay of repair" list in regular LDAR monitoring.

- (b) For valves: For valves, other than control valves, qualifying as Equipment leaking at a rate of 10,000 ppm or greater, require use of a "drill and tap" or equivalent method for fixing such leaking valves, rather than placing the valve on the "delay of repair" list, unless Valero or Tesoro, as applicable, can demonstrate that there is a safety, mechanical, or adverse environmental concern posed by attempting to repair the leak in this manner. Valero or Tesoro, as applicable, shall perform the first "drill and tap" (or equivalent repair method) within fifteen (15) days, and a second attempt (if necessary) within thirty (30) days after the leak is detected. After two unsuccessful attempts to repair a leaking valve through the drill and tap method, Valero or Tesoro, as applicable, may place the leaking valve on its "delay of repair" list. If a new method develops for repairing such valves, Valero or Tesoro, as applicable, will advise EPA prior to implementing the use of such new method in place of drill and tap for repairs required under this decree.

R. Recordkeeping and Reporting Requirements for this Part.

214. In addition to the Reports Required under 40 C.F.R. § 60.487 and § 63.654.

(a.) Written Refinery-Wide LDAR Program. No later than April 30, 2006, Valero shall submit a copy of each of Valero's Refineries' Written Refinery-Wide LDAR Programs and Tesoro shall submit a copy of Tesoro's Golden Eagle Refinery-Wide LDAR Program developed pursuant to Paragraph 185 to EPA, the appropriate EPA Region, and the appropriate Plaintiff-Intervener agency.

(b.) Certification of Use of Electronic Data Collection during LDAR Monitoring. No later than April 30, 2006, Valero shall certify that it utilizes at all of Valero's Refineries and Tesoro shall certify that it utilizes at the Golden Eagle Refinery, electronic data collection devices during LDAR monitoring, pursuant to the requirements of Paragraph 206.

215. As part of the Reports Required under 40 C.F.R. § 60.487 and § 63.654 (Semi-Annual LDAR Report) Valero shall submit, for Valero's Refineries, and Tesoro shall submit, for Tesoro's Golden Eagle Refinery, the following information, at the following times:

(a.) First Semi-Annual LDAR Report Due under the Consent Decree. Valero and Tesoro shall include the following as part of each company's report(s):

- (i.) A certification of the implementation of the "initial attempt at repair" program of Paragraph 199;
- (ii.) A certification of the implementation of QAI/QC procedures for review of data generated by LDAR technicians as required by Paragraph 207;
- (iii.) An identification of the individual, by name or title, at each Refinery responsible for LDAR performance as required by Paragraph 208;



- (iv.) A certification of the development of a tracking program for new valves and pumps added during maintenance and construction (Management of Change Program) as required by Paragraph 209;
- (v.) A certification of the implementation of the calibration and calibration drift assessment procedures of Paragraphs 210 and 211; and
- (vi.) A certification of the implementation of the "chronic leaker" and "delay of repair" procedures of Paragraphs 212 and 213.
- (vii.) A copy of each refinery's written refinery-wide LDAR program under Paragraph 185.

(b.) Until termination of this Part XI of the Consent Decree, in the Semi-Annual

LDAR Reports that Valero and Tesoro submit, Valero and Tesoro shall include:

- (i) An identification of each audit, if any, that was conducted pursuant to the requirements of Section XLD. in the previous semiannual period at each of Valero's Refineries and Tesoro shall include an identification of each audit, if any, that was conducted pursuant to the requirements of Section XLD in the previous semiannual period at Tesoro's Golden Eagle Refinery. For each audit identified, the report shall include an identification of the auditors, a summary of the audit results, and a summary of the actions that Valero or Tesoro, as applicable, took or intends to take to correct all deficiencies identified in the audits.
- (ii.) Training. Information identifying the measures taken to comply with the provisions of Paragraph 186; and

- (iii.) Monitoring. The following information on LDAR monitoring:
- (a) a list of the process units monitored during the reporting period;
 - (b) the number of valves and pumps present in each monitored process unit;
 - (c) the number of valves and pumps monitored in each process unit;
 - (d) the number of valves and pumps found leaking;
 - (e) the number of "difficult to monitor" pieces of equipment monitored;
 - (f) the projected month of the next monitoring event for that unit;
 - (g) a list of all pumps and valves currently on the "delay of repair" list, the date each component was placed on the list, the date each such component was determined to be leaking at a rate greater than 10,000 ppm, the date each drill and tap or equivalent method of repair, its associated monitoring results and whether such activities were completed in a timely manner under Paragraph 213;
 - (h) a list of all initial attempts/remonitoring that did not occur in a timely manner under Paragraph 199;
 - (i) the number of missed or untimely repairs under Paragraph 198; and
 - (j) the number of missed or untimely repairs under Paragraphs 212 and 213.

216. Reserved.

S. Agencies to Receive Reports, Plans and Certification Required in this Part XI:

Number of Copies.

217. Unless otherwise specified in this Part XI, Valero and Tesoro shall submit all reports, plans and certifications required to be submitted under this Part XI to EPA and to the appropriate EPA Region and Plaintiff-Intervener. For each submission, Valero and Tesoro shall

submit one copy to EPA, two copies to the appropriate EPA Region and two copies to the appropriate Plaintiff-Intervener. By agreement between Valero and each of the offices that are to receive the materials in this Part XI, Valero may submit the materials electronically.

T. Excluded Equipment.

218. Notwithstanding anything to the contrary in this Part XI, the LDAR program shall not apply to valves and pumps exempt under the LDAR Regulations, including but not limited to: pressure relief devices, valves on closed vent systems, valves in vacuum service, leakless valves, and pumps with no mechanism to leak (e.g. canned and mag pumps). In addition, nothing in this Consent Decree is intended to require Valero or Tesoro to monitor difficult-to-monitor valves or unsafe-to-monitor valves more frequently than is otherwise required under the LDAR Regulations.

U. New Monitoring Technologies.

219. In the event that EPA adopts new monitoring technologies (such as infrared imaging) into its LDAR regulations in the future, Valero or Tesoro, as applicable, may request a modification to this Part XI to take advantage of such new regulations. EPA, after an opportunity for consultation with appropriate Plaintiff-Interveners, may approve a change to part or all of this Part XI to take advantage of the new leak detection technology. Such a revised protocol must be developed and mutually agreed upon in writing by EPA and Valero or Tesoro, as applicable, in accordance with Paragraph 381 [Modification].

XII. PROGRAM ENHANCEMENTS RE: NSPS SUBPARTS A AND J SO₂ EMISSIONS FROM CLAUS SULFUR RECOVERY PLANTS ("SRP") AND FLARING

Program Summary: Beginning immediately upon the lodging of this Consent Decree, Valero agrees to take the following measures at all of its SRPs and certain flaring devices at Valero's Refineries. Valero will install additional equipment at certain refineries to achieve additional SO₂ emission reductions and further reduce flaring incidents. Valero will implement procedures for root cause analysis of acid gas and hydrocarbon flaring incidents and tail gas incidents at all refineries. Tesoro agrees to undertake the measures set forth in this Part at Tesoro's Golden Eagle Refinery.

A. DEFINITIONS.

220. Unless otherwise expressly provided herein, terms used in this Part shall be interpreted as defined in the Clean Air Act, 42 U.S.C. § 7401 et seq., and the applicable regulations promulgated there under. In addition, the following definitions shall apply, for purposes of this Consent Decree, to the terms contained within this Part of this Consent Decree:

- (1) "Acid Gas" (AG) shall mean any gas that contains hydrogen sulfide and is generated at a refinery by the regeneration of an amine scrubber solution;
- (2) "AG Flaring" shall mean, for purposes of this Consent Decree, the combustion of Acid Gas and/or Sour Water Stripper Gas in an AG Flaring Device. Nothing in this definition shall be construed to modify, limit, or affect EPA's authority to regulate the flaring of gases that do not fall within the definitions contained in this Consent Decree of Acid Gas or Sour Water Stripper Gas.
- (3) "AG Flaring Device" shall mean any device at a refinery that is used for the purpose of combusting Acid Gas and/or Sour Water Stripper Gas, except facilities in which gases are combusted to produce elemental sulfur, sulfuric acid or ammonium thiosulfate. The combustion of Acid Gas and/or Sour Water Stripper Gas occurs in AG



Flaring Devices identified in Appendix K. To the extent that the refinery utilizes AG Flaring Devices other than those identified in Appendix K for purposes of combusting Acid Gas and/or Sour Water Stripper Gas, those Flaring Devices shall be considered AG Flaring Devices under this Consent Decree.

(4.) "AG Flaring Incident" shall mean the continuous or intermittent flaring/combustion of Acid Gas and/or Sour Water Stripper Gas in an AG Flaring Device that results in the emission of sulfur dioxide equal to, or greater than five hundred (500) pounds in a twenty-four (24) hour period; provided, however, that if five hundred (500) pounds or more of sulfur dioxide have been emitted in a twenty-four (24) hour period and flaring continues into subsequent, contiguous, non-overlapping twenty-four (24) hour periods), each period of which results in emissions equal to, or in excess of five hundred (500) pounds of sulfur dioxide, then only one AG Flaring Incident shall have occurred. Subsequent, contiguous, non-overlapping periods are measured from the initial commencement of flaring within the AG Flaring Incident.

(5.) "Day" shall mean a calendar day.

(6.) "Hydrocarbon Flaring" shall mean, for purposes of this Consent Decree, the flaring of refinery hydrocarbon process gases, except for Acid Gas and/or Sour Water Stripper Gas and/or Tail Gas, in a Hydrocarbon Flaring Device. Nothing in this definition shall be construed to modify, limit, or affect EPA's authority to regulate the flaring of gases that do not fall within the definitions contained in this Consent Decree.

(7.) "Hydrocarbon Flaring Device" shall mean a flare device listed in Appendix N at Valero's Refineries or Tesoro's Golden Eagle Refinery. Valero or Tesoro, as applicable,



shall provide notice to EPA, within the next report to be submitted pursuant to Part XVI, of any new Hydrocarbon Flaring Device which is installed at a refinery, subject to this Consent Decree subsequent to the Date of Entry of this Consent Decree. To the extent that the refinery utilizes Hydrocarbon Flaring Devices other than those specified on Appendix N for the purposes of combusting any excess of a refinery-generated gas other than Acid Gas and/or Sour Water Stripper Gas, those Hydrocarbon Flaring Devices shall be covered under this Consent Decree.

(8.) "Hydrocarbon Flaring Incident" or HC Flaring Incident, shall mean continuous or intermittent Hydrocarbon Flaring, at a Hydrocarbon Flaring Device that results in the emission of sulfur dioxide equal to, or greater than five hundred (500) pounds in a 24-hour period; provided, however, that if five hundred (500) pounds or more of sulfur dioxide have been emitted in a twenty-four (24) hour period and flaring continues into subsequent, contiguous, non-overlapping twenty-four (24) hour period(s), each period of which results in emissions equal to, or in excess of five-hundred (500) pounds of sulfur dioxide, then only one HC Flaring Incident shall have occurred. Subsequent, contiguous, non-overlapping periods are measured from the initial commencement of Flaring within the HC Flaring Incident.

(9.) "Malfunction" shall mean any sudden, infrequent, and not reasonably preventable failure of air pollution control equipment, process equipment, or a process to operate in a normal or usual manner. Failures that are caused in part by poor maintenance or careless operation are not malfunctions.

- (10.) "Root Cause" shall mean the primary cause or causes of a AG or He Flaring Incident or of a Tail Gas Incident as determined through a process of investigation.
- (11.) "Scheduled Maintenance" of an SRP shall mean any shutdown of an SRP that Valero or Tesoro, as applicable, schedules at least fourteen (14) days in advance of the shutdown for the purpose of undertaking maintenance of that SRP.
- (12.) "Shutdown" shall mean the cessation of operation of an affected facility for any purpose.
- (13.) "Sour Water Stripper Gas" or "SWS Gas" shall mean the gas produced by the process of stripping or scrubbing refinery sour water.
- (14.) "Startup" shall mean the setting in operation of an affected facility for any purpose.
- (15.) "Sulfur Recovery Plant" or "SRP" shall mean a process unit that recovers sulfur from hydrogen sulfide by a vapor phase catalytic reaction of sulfur dioxide and hydrogen sulfide.
- (16.) "Tail Gas" shall mean exhaust gas from the Claus trains and the tail gas treating unit ("TGTH") section of the SRP.
- (17.) "Tail Gas Incident" shall mean the combustion of Tail Gas that:
- (a) is combusted in a flare that results in five hundred (500) pounds of sulfur dioxide emissions in a twenty-four (24) hour period; or
 - (b) is combusted in a thermal incinerator and results in excess emissions of 500 pounds or more of SO₂ in any 24-hour period. Only those time periods which are in excess of a SO₂ concentration of 250 ppm (rolling 12-hour average) shall be used

to determine the amount of excess S02 emissions from the incinerator; provided, however, that during periods of maintenance of a monitored incinerator, a Tail Gas Incident shall mean the combustion of Tail Gas in a combustion device other than a monitored incinerator where the amount of sulfur dioxide emissions in excess of 250 ppm on a twenty-four (24) hour period exceeds five hundred (500) pounds, calculated based upon best engineering judgment.

(c) Notwithstanding subparagraphs (a) and (b) above, as to the Golden Eagle SRP, the Houston SRP, the McKee SRP, the Benicia SRP, and the Wilmington SRP from the Date of Lodging to the NSPS compliance date identified in Paragraph 222 a Tail Gas Incident shall mean any S02 emission in excess of currently permitted levels. Additionally, a Tail Gas Incident for the Denver SRP from the Date of Lodging through the NSPS compliance date in Paragraph 223 shall mean any S02 emission in excess of currently permitted levels.

(18.) "Upstream Process Units" shall mean all amine contactors, amine scrubbers, and sour water strippers at the refinery, as well as all process units at the refinery that produce gaseous or aqueous waste streams that are processed at amine contactors, amine scrubbers, or sour water strippers.

(19.) "Flaring Device" shall mean an Acid Gas Flaring Device and/or Hydrocarbon Flaring Device.

B. SRP NSPS SUBPARTS A and J APPLICABILITY

221. In accordance with the schedule provided in Paragraph 222 and 223, the SRPs at Valero's Refineries and Tesoro's Golden Eagle Refinery shall be "affected facilities" pursuant to

40 C.F.R. Part 60, Subpart J, and shall comply with the applicable provisions of 40 C.F.R. Part 60, Subparts A and J, as such requirements apply to SRPs.

222. The SRPs at Valero's Refineries and Tesoro's Golden Eagle Refinery are as follows:

SRP	Trains Comprising an SRP	NSPS Applicability Date
Ardmore SRP	SRU No. 1	Date of Lodging
Benicia SRP	SRU A SRUB	December 31, 2005
Corpus Christi East SRP	SRU No. 1 SRUNo.2	Date of Lodging
Corpus Christi West SRP	SRU No. 1 SRUNo.2 SRUNo.3	Date of Lodging
Denver SRP	SRU No. 1	NA- Less than 20 LTPD
Houston SRP	SRU B	December 31, 2006
McKee SRP	SRU No. 1 SRUNo.2	December 31, 2006
Paulsboro SRP	SRU No.2 SRUNo.3	Date of Lodging
St Charles SRP	SRU No. 1 SRUNo.2	Date of Lodging
Texas City SRP	SRU No. 1 SRUNo.2	Date of Lodging
Texas City South Plant SRP	South Plant SRU	Date of Lodging
Three Rivers SRP	SRU No. 1	Date of Lodging
Wilmington SRP	SRU No. 1 SRUNo.2	December 31, 2005

Golden Eagle SRP

SRU

December 31, 2006

223. The SRP at the Denver Refinery processes less than twenty (20) long tons per day (LTD) sulfur. Pursuant to EPA Enforcement, Civil Action No. 99-N-1759, EPA oversaw a Denver Refinery SRP optimization study. Valero shall conduct a new, updated SRP optimization study. This study shall be limited to the optimization of the existing SRP equipment and design, may include physical changes to the SRP but shall not require capital expenditures exceeding 7.5 % of the total installed cost of a comparably new SRP. Valero's optimization study shall meet the following minimum requirements:

- (a) Detailed evaluation of plant design capacity based on plant operating conditions including catalytic activity and the expected composition of the acid gas and sour water stripper gas feed to the SRP;
- (b) A thorough review of each of the existing critical pieces of process equipment and instrumentation within the Claus train that is designed to correct operational deficiencies or problems that prevent the Claus train from achieving its optimal sulfur recovery efficiency;
- (c) Establishment of expected sulfur recovery efficiency based on testing and measurement of key parameters throughout the Claus train; and
- (d) For any key parameters that have been determined to be at less than optimal levels, initiation of logical, sequential, or stepwise changes designed to move such parameters toward their optimal values.

By no later than December 31, 2007, Valero shall implement the study's recommendations, submit the Denver SRP optimization report to EPA and the CDPHE and may then propose a schedule for completion of the study's recommendations, if necessary and as appropriate. In the report Valero shall submit for EPA approval a proposed mass based emission limit premised on optimized SRP performance as reflected in the optimization review. Valero shall, to the extent

practicable, operate and maintain the Denver SRP and supplemental control devices, if any, through implementation of good air pollution control practices consistent with 40 CFR 60.11 (d). In the event that Valero modifies the Denver SRP during the term of this Consent Decree such that the Denver SRP processes greater than twenty (20) **LTD** offeed inputsulfur, then the SRP located at the Denver Refinery shall be considered an "affected facility pursuant to 40 C.F.R. Part 60, Subpart J, and shall comply with the applicable provisions of 40 C.F.R. Part Subparts A and J, as such requirements apply to SRPs.

224. By no later than the refinery-specific dates for NSPS applicability set out in Paragraphs 222 and 223, all emission points (stacks) to the atmosphere for tail gas emissions from each of its SRPs will be monitored and reported upon in accordance with 40 C.F.R. §§ 60.7(c), 60.13, and 60.105. This requirement is not applicable to the AG Flaring Devices identified in Appendix K.

225. Nothing in this Consent Decree shall be interpreted to limit Valero's or Tesoro's opportunity to submit for EPA approval alternative monitoring procedures or requirements pursuant to 40 C.F.R., Part 60, Subpart for emissions from SRPs.

226. By no later than one (1) year after the Date of Entry or the date for NSPS applicability for each SRP established in Paragraphs 221 - 223, whichever date is later, Valero and Tesoro, as applicable, shall re-route any SRP sulfur pit emissions from the refineries subject to this Consent Decree such that all sulfur pit emissions to the atmosphere are either eliminated or included as part of the applicable SRP's emissions subject to NSPS Subpart J limit for S02, as a 12-hour rolling average, of 250 ppmvd or 300 ppm reduced sulfur, each at 0% oxygen, as required by 40 C.F.R. § 60.104(a)(2). By no later than December 31, 2006, the Denver Refinery

will re-route its SRP sulfur pit emissions such that all sulfur pit emissions to the atmosphere are either eliminated or routed to the tail gas incinerator and included within the mass-based emission limit established by EPA under Paragraph 223.

227. During the life of this Consent Decree and for the purpose of determining compliance with the SRP emission limits, Valero and Tesoro shall apply the "startup" and "shutdown" provisions set forth in NSPS Subpart A to the SRP but not to the independent startup or shutdown of its corresponding control device(s) (e.g., TGTU). However, the malfunction exemption set forth in NSPS Subpart A shall apply to both the SRP and its control device(s) (e.g., TGTU).

228. In order to further enhance operations of its SRPs, further reduce emissions of SO₂, further reduce AO Flaring Incidents and ensure compliance with 40 C.F.R. Part 60, Subpart J, Valero shall implement the following actions by the dates listed below:

- a. By no later than December 31, 2005, Valero shall install an additional Claus and amine based TOU on the SRP at the Three Rivers Refinery.
- b. By no later than December 31, 2005, Valero shall install an additional amine based TOU on the SRP at the Wilmington Refinery.
- c. By no later than December 31, 2006, Valero shall install an additional Claus and amine based TOU on the SRP at the Ardmore Refinery.
- d. By no later than December 31, 2006, Valero shall install an additional Claus and TGU on the SRP at the Houston Refinery. The new TGU will replace the existing BSR Selectox TOU with an amine based TOU.



- e. By no later than December 31, 2006, Valero shall install a second amine based TGU on the SRP at the McKee Refinery.
- f. By December 31, 2006, Valero shall replace the two existing Bevon-Stretford tail gas treatment units at the Paulsboro refinery with amine based tail gas treatment units.
- g. By no later than December 31, 2007, Valero shall install an additional Claus and amine based TGU on the SRP at the St. Charles Refinery.

229. Good Operation and Maintenance. By no later than December 31, 2005, Valero and Tesoro, as applicable, shall submit to EPA and the appropriate Plaintiff-Intervener, a summary of at least seven Refineries' plans for enhanced maintenance and operation of their SRPs, sulfuric acid plants, any supplemental control devices, and the appropriate Upstream Process Units that have been or will be implemented; by no later than December 31, 2006, Valero shall submit to EPA and the appropriate Plaintiff-Intervener a summary of the remaining Refineries' plans. These plans shall be termed Preventive Maintenance and Operation Plans ("PMO Plans"). Each PMO Plan shall be a compilation of Valero or Tesoro, as applicable, approaches for exercising good air pollution control practices and for minimizing 802 emissions at its Refinery(ies). The PMO Plan shall provide for continuous operation of its SRPs and sulfuric acid plants between scheduled maintenance turnarounds with minimization of emissions, including the continued use of supplemental control devices (e.g., amine/caustic scrubbers). The PMO Plan shall include, but not be limited to, sulfur shedding procedures, startup and shutdown procedures, hot standby procedures, emergency procedures and schedules to coordinate maintenance turnarounds of the SRP Claus trains, sulfuric acid plants, and any supplemental control devices with scheduled turnarounds of major Upstream Process Units. The PMO Plan

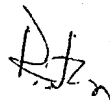

shall have as a goal the elimination of Acid Gas Flaring. Valero or Tesoro, as applicable, shall comply with the PMO Plan at all times, including periods of Startup, Shutdown and Malfunction of its SRPs. If Valero or Tesoro, as applicable, makes changes to a PMO Plan related to minimizing Acid Gas Flaring and/or SO₂ emissions, such changes shall be summarized and reported to EPA and the appropriate Plaintiff-Intervener on an annual basis.

229A. In addition, Valero and Tesoro, as applicable, shall, along with each PMO described above, provide a brief description of the causes of Acid Gas Flaring at each refinery for each Acid Gas Flaring Incident that occurred from January 1, 2000 through December 31, 2004:

1. The date and time that the AG Flaring Incident started and ended (if available or reasonably determinable);
- ii. An estimate of the quantity of sulfur dioxide emitted and the calculations used to determine that quantity (if available or reasonably determinable); and
- iii. A description of the Root Cause and corrective actions, if any, that were taken and/or should be incorporated into the PMO to reduce the likelihood of a recurrence of such AG Flaring Incident (if reasonably available but only to the extent such Refinery was then owned by Valero or Tesoro).

230. EPA and the appropriate Plaintiff-Intervener do not, by their review of a PMO Plan and/or by their failure to comment on a PMO Plan, warrant or aver in any manner that any of the actions that Valero or Tesoro, as applicable, may take pursuant to such PMO Plan will result in compliance with the provisions of the Clean Air Act or any other applicable federal, state, or local law or regulation. Notwithstanding EPA's or appropriate Plaintiff-Intervener's review of a



PMO Plan, Valero or Tesoro, as applicable, shall remain solely responsible for compliance with the Clean Air Act and such other laws and regulations.

C. **FLARING DEVICES - NSPS APPLICABILITY**

231. In accordance with the schedule in this Section XILC, Valero and Tesoro, as applicable, accept NSPS Subpart J applicability for each Flaring Device at their refineries, as currently identified in Appendix N.

232. Upon the Date of Entry of this Consent Decree, Valero shall continue to operate the existing flare gas recovery systems at the Wilmington, Benicia and Paulsboro Refineries on those flares covered by such systems. Valero will accept NSPS Subpart J applicability to all flares at the Wilmington Refinery and the North Flare at the Benicia Refinery beginning December 31, 2006.

233. Upon the Date of Entry of this Consent Decree, Tesoro shall continue to operate the existing flare gas recovery system at the Golden Eagle Refinery on those flares covered by the system.

234. Good Air Pollution Control Practices. On and after the Date of Entry, Valero or Tesoro, as applicable, shall at all times and to the extent practicable, including during periods of Startup, Shutdown, and/or Malfunction, implement good air pollution control practices for minimizing emissions consistent with 40 C.F.R. § 60.11(d).

235. For each Flaring Device, Valero or Tesoro, as applicable, will elect to use one or any combination of following NSPS Subpart J compliance methods:

- (a) Operate and maintain a flare gas recovery system to control continuous or routine combustion in the Flaring Device. Use of a flare gas recovery system on a flare

obviates the need to continuously monitor and maintain records of hydrogen sulfide in the gas as otherwise required by 40 C.F.R. §§ 60.105(a)(4) and 60.7;

- (b) Operate the Flaring Device as a fuel gas combustion device and comply with NSPS monitoring requirements by use of a CEMS pursuant to 40 C.F.R. § 60.105(a)(4) or with a predictive monitoring system approved by EPA as an alternative monitoring system pursuant to 40 C.F.R. § 60.13(i);
- (c) Eliminate the routes of continuous or intermittent, routinely-generated fuel gases to a Flaring Device and operate the Flaring Device such that it receives only process upset gases, fuel gas released as a result of relief valve leakage or gases released due to other emergency malfunctions; or
- (d) Eliminate to the extent practicable routes of continuous or intermittent, routinely-generated fuel gases to a Flaring Device and monitor the Flaring Device by use of a CEMS and a flow meter; provided however, that this compliance method may not be used unless Valero or Tesoro, as applicable: (i) demonstrates to EPA that the Flaring Device in question emits less than 500 pounds per day of SO₂ under normal conditions; (ii) secures EPA approval for use of this method as the selected compliance method; and (iii) uses this compliance method for five or fewer of the Flaring Devices listed in Appendix N.

236. For the compliance method described in Paragraph 235(b), to the extent that Valero or Tesoro, as applicable, seeks to use an alternative monitoring method at a particular Flaring Device to demonstrate compliance with the limits at 40 C.F.R. § 60.104(a)(1), Valero or Tesoro, as applicable, may begin to use the method immediately upon submitting the application for

approval to use the method, provided that the alternative method for which approval is being sought is the same as or is substantially similar to the method identified as the "Alternative Monitoring Plan for NSPS Subpart J Refinery Fuel Gas" attached hereto as Appendix D.

237. Compliance Plan for Flaring Devices. For each Covered Refinery, Valero or Tesoro, as applicable, will submit a Compliance Plan for Flaring Devices to EPA and the applicable Plaintiff-Intervener by no later than December 31, 2007.

238. In each Refinery's Compliance Plan for Flaring Devices, Valero or Tesoro, as applicable, will:

- (a) Certify compliance with one or more of the four compliance methods set forth in Paragraph 235 and accept NSPS applicability for at least (i) 50% of the system-wide Flaring Devices identified in Appendix N, including the Denver Refinery Flare; and (ii) one Flaring Device per Refinery where such Refinery has three or more Flaring Devices (Tesoro shall certify compliance with NSPS for at least 50% of the flares located at the Golden Eagle Refinery), provided, however, that if the selected compliance method is a flare gas recovery system, as identified in Paragraph 235(a), then Valero may certify that compliance will be achieved by no later than December 31, 2008;
- (b) Identify the Paragraph 235 compliance methods used for each Flaring Device that Valero or Tesoro, as applicable, identifies under Paragraph 237;

- (c) Describe the activities that Valero or Tesoro, as applicable, has taken or anticipates taking, together with a schedule, to meet the objectives of Paragraph 237 at each Refinery; and
- (d) Describe the anticipated compliance methods and schedule that Valero or Tesoro, as applicable, will undertake for the remaining Flaring Devices identified in Appendix N.

239. By no later than December 31, 2011, Valero or Tesoro, as applicable, will certify compliance to EPA and the applicable Plaintiff-Intervener with one or more of the four compliance methods in Paragraph 235 and will accept NSPS applicability for all of the Flaring Devices in Appendix N.

240. Performance Tests. By no later than ninety (90) days after bringing a Flaring Device into compliance by using the methods in Paragraph 235(b) or (d), Valero or Tesoro, as applicable, will conduct a flare performance test pursuant to 40 C.F.R. §§ 60.8 and 60.18, or an EPA-approved equivalent method unless such performance test has previously been performed. In lieu of conducting the velocity test required in 40 C.F.R. § 60.18, Valero or Tesoro, as applicable, may submit velocity calculations that demonstrate that the Flaring Device meets the performance specification required by 40 C.F.R. § 60.18.

241. The combustion in a Flaring Device of process upset gases or fuel gas that is released to the Flaring Device as a result of relief valve leakage or other emergency malfunctions is exempt from the requirement to comply with 40 C.F.R. § 60.104(a)(1).

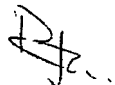

D. INVESTIGATION AND REPORTING

242. Beginning no later than ninety (90) days after the Date of Lodging, Valero or Tesoro, as applicable, shall submit a report to EPA and the applicable EPA Regional Office within sixty (60) days following the end of each AG Flaring Incident, Hydrocarbon Flaring Incident or Tail Gas Incident at a Valero Refinery or at Tesoro's Golden Eagle Refinery. Such reports shall set forth the following information concerning the Incident (a "Root Cause Failure Analysis" or "RCFA"):

- (1.) The date and time that the Incident started and ended. To the extent that the Incident involved multiple releases either within a twenty-four (24) hour period or within subsequent, contiguous, non-overlapping twenty-four (24) hour periods, Valero or Tesoro, as applicable, shall set forth the starting and ending dates and times of each release;
- (2.) An estimate of the quantity of SO₂ that was emitted and the calculations that were used to determine that quantity;
- (3.) The steps, if any, that Valero or Tesoro, as applicable, took to limit the duration and/or quantity of SO₂ emissions associated with the Incident;
- (4.) A detailed analysis that sets forth the Root Cause of that Incident, to the extent determinable;
- (5.) An analysis of the measures, if any, that are reasonably available to reduce the likelihood of a recurrence of the Incident resulting at the same refinery from the same Root Cause(s) in the future. The analysis shall discuss the alternatives, if any, that are reasonably available, the probable effectiveness and cost of the

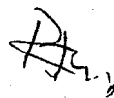

alternatives, and whether or not an outside consultant should be retained to assist in the analysis. Possible design, operational, and maintenance changes shall be evaluated.

- (6.) Either a description of corrective action(s) under Paragraph 245 and, if not already completed, a schedule for its (their) implementation, including proposed commencement and completion dates, or an explanation that corrective action(s) is (are) not required;
- (7.) For AG Flaring and Tail Gas Incidents only, a statement that:
 - (a.) Specifically identifies each of the grounds for stipulated penalties in Section XII.F of this Decree and describes whether or not such incident falls under any of those grounds;
 - (b.) Describes whether Paragraph 250 or 251 applies and why, or if such incident falls under Paragraph 252 of this Decree, describes whether subparagraph 252(a), (b), or (c) applies and why; and
 - (c.) States whether or not Valero or Tesoro, as applicable, asserts a defense to such incident, and if so, a description of such defense.
- (8.) To the extent that investigations of the causes and/or possible corrective actions still are underway on the due date of the report, a statement of the anticipated date by which a follow-up report fully conforming to the requirements of this Paragraph 242 will be submitted; provided, however, that if Valero or Tesoro, as applicable, has not submitted a report or a series of reports containing the information required to be submitted under this paragraph within sixty (60) days

(or such additional time as EPA may allow) after the due date for the initial report for any incident, the stipulated penalty provisions of Paragraph 260(d) shall apply for failure to timely submit the report. Nothing in this paragraph shall be deemed to excuse Valero or Tesoro, as applicable, from its investigation, reporting, and corrective action obligations under this Part XII for any incident which occurs after another incident for which Valero or Tesoro, as applicable, has requested an extension of time under this paragraph; and

- (9.) To the extent that completion of the implementation of corrective action(s), if any, is not finalized at the time of the submission of the report required under this Paragraph 242, then, by no later than thirty (30) days after completion of the implementation of corrective action(s), Valero or Tesoro, as applicable, shall submit a report identifying the corrective action(s) taken and the dates of commencement and completion of implementation.

243. With respect to HC Flaring Incidents and in lieu of analyzing possible corrective actions under Section XII.E and taking interim and/or long-term corrective action under that section for a Hydrocarbon Flaring Incident attributable to the startup or shutdown of a unit that Valero or Tesoro, as applicable, previously analyzed under this Section XII.D, Valero or Tesoro, as applicable, may identify such prior analysis when submitting the report required under Paragraph 242. Prior to the installation of a flare gas recovery system identified under Paragraph 235(a) but only after notice to EPA under Paragraph 237, Valero and Tesoro, as applicable, shall not be required to identify or implement corrective action(s) under Paragraphs 242 and 245, for HC Flaring Incidents unless more than 500 lbs. of 802 would have been released if such

equipment had been installed and in use. If Valero or Tesoro, as applicable, determines that the Hydrocarbon Flaring Incident is attributable solely to the combustion of refinery fuel gas that contains less than 162 ppm of H₂S, it shall so demonstrate in its report under Paragraph 242, and no further action shall be required for that Incident under this Section XII.D. In addition, or in the alternative, if Valero or Tesoro, as applicable, determines that the Hydrocarbon Flaring Incident is attributable to the combustion of a stream or streams of Continuous or Intermittent Routinely-Generated Fuel Gases prior to Valero or Tesoro's, as applicable, implementing actions to address such stream(s) when and as required by Paragraphs 235 and 238 but only after notice to EPA under Paragraph 237, it shall so demonstrate in its report under Paragraph 242 and no further action shall be required for that Incident under this Section XII.D. Notwithstanding Paragraph 242, Valero and Tesoro, as applicable, may submit Hydrocarbon Flaring Incident reports as part of the Semi-annual Progress Reports required pursuant to Part XVI.

244. With respect to Hydrocarbon Flaring Incidents occurring prior to its certifying compliance under Paragraph 238 or 239, Valero or Tesoro may prepare and submit a single RCFA for one or more Root Causes found by that analysis to routinely reoccur. Valero or Tesoro, as applicable, shall inform the EPA and the relevant Plaintiff-Intervener in that RCFA that it is electing to report only once on that (those) Root Cause(s) during the interim period. Unless EPA or the relevant Plaintiff-Intervener objects within thirty (30) days of receipt of the RCFA, such election shall be effective.

E. CORRECTIVE ACTION

245. In response to any Incident, Valero or Tesoro, as applicable, as expeditiously as reasonably practicable shall take such interim and/or long-term corrective actions, if any, as are

reasonable and consistent with good engineering practice to minimize the likelihood of a recurrence of the Root Cause of that Incident.

246. If EPA does not notify Valero or Tesoro in writing within sixty (60) days of receipt of the report(s) required by Paragraph 242 that it objects to one or more aspects of Valero's or Tesoro's proposed corrective action(s), if any, and schedule(s) of implementation, if any, then that (those) action(s) and schedule(s) shall be deemed acceptable for purposes of compliance with Paragraph 245 of this Consent Decree.

247. EPA does not, by its agreement to the entry of this Consent Decree or by its failure to object to any corrective action that Valero or Tesoro may take in the future, warrant or aver in any manner that any of Valero's or Tesoro's corrective actions in the future will result in compliance with the provisions of the Clean Air Act or its implementing regulations.

Notwithstanding EPA's review of any plans, reports, corrective actions or procedures under this Part XII, Valero and Tesoro, as applicable, shall remain solely responsible for non-compliance with the Clean Air Act and its implementing regulations. Nothing in this paragraph shall be construed a waiver of EPA's rights under the Clean Air Act and its regulations for future violations of the Act or its regulations.

248. If EPA does object, in whole or in part, to Valero's or Tesoro's proposed corrective action(s) and/or its schedule(s) of implementation, or, where applicable, to the absence of such proposal(s) and/or schedule(s), it shall notify Valero or Tesoro, as applicable, of that fact within sixty (60) days following receipt of the RCFA required by Paragraph 242. EPA shall not, in such notice, amend or modify the schedule of activities identified in Paragraph 228. If EPA and Valero or Tesoro, as applicable, cannot agree on the appropriate corrective action(s), if any, to be

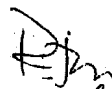

taken in response to a particular Incident, either Party may invoke the Dispute Resolution provisions of Part XXIII of the Consent Decree.

F. AG FLARING AND TAIL GAS INCIDENTS AND STIPULATED PENALTIES

249. The provisions of this Section XII.F are intended to implement the process outlined in the logic diagram attached hereto as Appendix F to this Consent Decree. These provisions shall be interpreted and construed, to the maximum extent feasible, to be consistent with that Appendix. However, in the event of a conflict between the language of those paragraphs and Appendix F, the language of those paragraphs shall control.

250. The stipulated penalty provisions of Paragraph 260(a) shall apply to any Acid Gas Flaring or Tail Gas Incident for which the Root Cause was one or more of the following acts, omissions, or events:

- a. Error resulting from careless operation by the personnel charged with the responsibility for the Sulfur Recovery Plant, TGU, or Upstream Process Units;
- b. Failure to follow written procedures; and
- c. A failure of a part, equipment or system that is due to a failure by Valero or Tesoro, as applicable, to operate and maintain that part, equipment or system in a manner consistent with good engineering practice.

251. If the AG Flaring or Tail Gas Incident is not a result of one of the root causes identified in Paragraph 250, then the stipulated penalty provisions of Paragraph 260(a) shall apply if the AG Flaring or Tail Gas Incident:

- a. Results in emissions of sulfur dioxide at a rate greater than twenty (20.0) pounds per hour continuously for three (3) consecutive hours or more and Valero or Tesoro, as applicable, failed to act consistent with the PMO Plan and/or to take any action during the Incident to limit the duration and/or quantity of 802 emissions associated with such incident; or
- b. Causes the total number of Acid Gas Flaring Incidents or, separately, Tail Gas Incidents in a rolling twelve (12) month period to exceed five (5). In the event that an Incident falls under both Paragraphs 250 and 251, then Paragraph 250 shall apply.

252. With respect to any AG Flaring or Tail Gas Incident not identified in Paragraph 250 or 251, the following provisions shall apply:

- a. Agreed Upon Malfunction: If the Root Cause of the Incident was sudden, infrequent, and not reasonably preventable through the exercise of good engineering practice, then that cause shall be designated as an agreed-upon malfunction for purposes of reviewing subsequent Incidents, and the stipulated penalty provisions of Paragraph 260 shall not apply.

- b. First Time: If the Root Cause of the Incident was sudden and infrequent but reasonably preventable through the exercise of good engineering practices then Valero or Tesoro, as applicable, shall implement corrective action(s) pursuant to Paragraph 245 and the stipulated penalty provisions of Paragraph 260 shall not apply.

- c. Recurrence: If the Root Cause of the Incident is a recurrence of the same Root Cause that caused a previous Incident occurring after the Date of Entry, then the stipulated penalty provisions of Paragraph 260(a) shall apply unless either the Root Cause of the previous

Incident was designated as an Agreed Upon Malfunction under Paragraph 252.a, or Valero or Tesoro, as applicable, was in the process of timely developing or implementing a corrective action plan under Paragraphs 242 and 245 for such previous Incident.

253. Defenses: Valero or Tesoro, as applicable, may raise the following affirmative defenses in response to a demand by the United States for stipulated penalties:

- a. Force majeure.
- b. As to Paragraph 250, the Incident does not meet the identified criteria.
- c. As to Paragraph 251, the Incident does not meet the identified criteria and/or was due to a Malfunction.
- d. As to Paragraph 252, the Incident does not meet the identified criteria, was due to a Malfunction and/or Valero or Tesoro, as applicable, was in the process of timely developing or implementing a corrective action plan under Paragraphs 242 and 245 for the previous Incident. In the event a dispute under Paragraph 250 or 251 is brought to the Court pursuant to the Dispute Resolution provisions of this Consent Decree, Valero or Tesoro, as applicable, may also assert a startup, shutdown and/or upset defense, but the United States shall be entitled to assert that such defenses are not available. If Valero or Tesoro, as applicable, prevails in persuading the Court that the defenses of startup, shutdown and/or upset are available for Incidents under 40 C.F.R. § 60.104(a)(I), Valero or Tesoro, as applicable, shall not be liable for stipulated penalties for emissions resulting from such startup, shutdown and/or upset. If the United States prevails in persuading

the Court that the defenses or startup, shutdown and/or upset are not available, Valero or Tesoro, as applicable, shall be liable for such stipulated penalties.

254. Other than for a Malfunction or force majeure, if no Incident and no violation of the emission limits under section XII.B occurs at a Refinery for a rolling 36 month period, then the stipulated penalty provisions of Paragraph 260(a) shall no longer apply to that Refinery. EPA may elect to prospectively reinstate the stipulated penalty provision if Valero or Tesoro, as applicable, has an Incident which would otherwise be subject to stipulated penalties. EPA's decision shall not be subject to dispute resolution. Once reinstated, the stipulated penalty provision shall continue for the remaining life of this Consent Decree for that Refinery.

G. MISCELLANEOUS

255. Calculation of the Quantity of Sulfur Dioxide Emissions resulting from AG Flaring. For purposes of this Consent Decree, the quantity of SO₂ emissions resulting from AG Flaring shall be calculated by the following formula:

$$\text{Tons of SO}_2 = [\text{FR}][\text{TD}][\text{ConcH}_2\text{S}][8.31 \times 10^{-5}].$$

The quantity of SO₂ emitted shall be rounded to one decimal point. (Thus, for example, for a calculation that results in a number equal to 10.050 tons, the quantity of SO₂ emitted shall be rounded to 10.1 tons and 10.049 tons would be rounded to 10.0 tons.) For purposes of determining the occurrence of, or the total quantity of SO₂ emissions resulting from, an AG Flaring Incident that is comprised of intermittent AG Flaring, the quantity of SO₂ emitted shall be equal to the sum of the quantities of SO₂ flared during each such period of intermittent AG Flaring.

256. Calculation of the Rate of S02 Emissions during AG Flaring. For purposes of this Consent Decree, the rate of S02 emissions resulting from AG Flaring shall be expressed in terms of pounds per hour, and shall be calculated by the following formula:

$$ER = [FR][ConcH2S][0.166].$$

The emission rate shall be rounded to one decimal point. (Thus, for example, for a calculation that results in an emission rate of 19.950 pounds of S02 per hour, the emission rate shall be rounded to 20.0 pounds of S02 per hour; for a calculation that results in an emission rate of 19.949 pounds of S02 per hour, the emission rate shall be rounded to 19.9.)

257. Meaning of Variables and Derivation of Multipliers used in the Equations in Paragraphs 255 and 256:

ER = Emission Rate in pounds of Sulfur Dioxide per hour

FR = Average Flow Rate to Flaring Device(s) during Flaring, in standard cubic feet per hour

TD = Total Duration of Flaring in hours

ConcH2S = Average Concentration of Hydrogen Sulfide in gas during Flaring (or immediately prior to Flaring if all gas is being flared) expressed as a volume fraction (scfH2S/scfgas)

$$8.31 \times 10^{-5} = [\text{lb. mole H}_2\text{S}/385 \text{ scfH}_2\text{S}][64 \text{ lbs. S}_02/\text{lb. mole H}_2\text{S}][\text{Ton}/2000 \text{ lbs.}]$$

$$0.166 = [\text{lb. mole H}_2\text{S}/385 \text{ scfH}_2\text{S}][1.0 \text{ lb mole S}_02/1 \text{ lb. mole H}_2\text{S}][64 \text{ lb. S}_02/1.0 \text{ lb. mole S}_02]$$

Standard conditions: 68 deg. F, 14.7 lbAorce/sq.in. absolute

The flow of gas to the AG Flaring Device(s) ("FR") shall be as measured by the relevant flow meter or as calculated through the exercise of best engineering judgment. Hydrogen sulfide concentration ("ConcH2S") shall be determined from any installed SRP feed gas analyzer. In the

event that the flow of gas is not measured by an SRP feed gas analyzer or the datapoint is inaccurate, the missing or inaccurate data points) shall be estimated according to best engineering judgment. The report required under Paragraph 242 shall include the data used in the calculation and an explanation of the basis for any estimates of missing data points.

258. Calculation of the Quantity of SO₂ Emissions resulting from a Tail Gas Incident.

For the purposes of this Consent Decree, the quantity of SO₂ emissions resulting from a Tail Gas Incident shall be calculated by one of the following methods or an equivalent method approved by EPA, based on the type of event:

- (a.) If the event constitutes a Tail Gas Incident meeting the definition of Paragraph 220(17)(a), the SO₂ emissions are calculated using the methods outlined in Paragraph 255, or
- (b.) If the event constitutes a Tail Gas Incident meeting the definition of Paragraph 220(17)(b), then the following formula applies to each twenty-four (24) hour period of an incident beginning with the first hour that the rolling twelve (12) hour average SO₂ concentration exceeds the 250 ppmvd Subpart J limit and ending with the twenty-four (24) hour period in which the 250 ppmvd NSPS limit is last exceeded. Total SO₂ emissions during an incident are determined by summing the emissions during each twenty-four (24) hour period of the incident:

$$ERTG = \sum_{i=1}^{HTG} [FR_{Inc,i} [Cone. SO_2 - 250]_i [(20.9 - \%O_2)/20.9]_i [0.166 \times 10^{-6}]$$

Where:

ERTG = Excess Emissions from Tail Gas at the SRP incinerator, in SO₂ lbs. over a twenty-four (24) hour period

FRIne. = Incinerator Exhaust Gas Flow Rate (standard cubic feet per hour, dry basis) (actual stack monitor data or engineering estimate based on the acid gas feedrate to the SRP) for each hour of the incident.

Cone. S02: Actual S02 concentration (CEM data) in the incinerator exhaust gas, ppmvd adjusted to 0% O₂ for each hour of the incident

% O₂ = O₂ concentration (CEM data) in % in the incinerator exhaust gas in ppm on dry basis for each hour of the incident

$0.166 \times 10^{-6} = [\text{lb. mole of S02} / 385 \text{ S02}] [64 \text{ lbs. S02} / \text{lb. mole S02}] [1 \times 10^{-6}]$

HTm = Hours when the incinerator CEM was exceeding 250 ppmvd adjusted to 0% O₂ in each twenty-four (24) hour period of the incident (as described above).

Standard conditions: 68 deg. F, 14.7 lb.-force/sq.in. absolute

In the event the S02 and/or the O₂ CEM hourly concentration data are inaccurate or not available or a flow meter for FRIne, does not exist or is inoperable, then estimates will be used based on best engineering judgment.

259. Any disputes under the provisions of this Part XII shall be resolved in accordance with Part XXIII (Dispute Resolution) of this Consent Decree.

H. STIPULATED PENALTIES UNDER THIS PART.

260. Nothing in this Part XII shall be understood to subject Valero or Tesoro to stipulated penalties for HC Flaring Incidents under Paragraph 260(a). Valero or Tesoro, as applicable, shall be liable for the following stipulated penalties for violations of the requirements of this Part. For each violation, the amounts identified below apply on the first day of violation, and are calculated for each incremental period of violation (or portion thereof):



(a.) AG Flaring Incidents for which Valeroor Tesoro, as applicable, is liable under this Part.

Tons Emitted in AG Flaring Incident	Length of Time from Commencement of Flaring within the AG Flaring Incident to Termination of Flaring within the AG Flaring Incident is 3 hours or less	Length of Time from Commencement of Flaring within the AG Flaring Incident to Termination of Flaring within the AG Flaring Incident is greater than 3 hours but less than or equal to 24 hours	Length of Time from Commencement of Flaring within the AG Flaring Incident to Termination of Flaring within the AG Flaring Incident is greater than 24 hours
5 Tons or Less	\$500 per ton	\$750 per ton	\$1000 per ton
Greater than 5 tons, but less than or equal to 15 tons	\$1,200 per ton	\$1,800 per ton	\$2,300 per ton, up to, but not exceeding, \$27,500 in anyone calendar day
Greater than 15 tons	\$1,800 per ton, up to, but not exceeding, \$27,500 in anyone calendar day	\$2,300 per ton, up to, but not exceeding, \$27,500 in anyone calendar day	\$27,500 per calendar day

- (i.) For purposes of calculating stipulated penalties pursuant to this subparagraph, only one cell within the matrix shall apply. Thus, for example, for an AG Flaring Incident in which the AG Flaring starts at 1:00 p.m. and ends at 3:00 p.m., and for which 14.5 tons of sulfurdioxide are emitted, the penalty would be \$17,400 (14.5 x \$1,200); the penalty would not be \$13,900 [(5 x \$500) + (9.5 x \$1200)].
- (ii.) For purposes of determining which column in the table set forth in this subparagraph applies under circumstances in which AG Flaring occurs

R.T.

intermittently during an AG Flaring Incident, the AG Flaring shall be deemed to commence at the time that the AG Flaring that triggers the initiation of an AG Flaring Incident commences, and shall be deemed to terminate at the time of the termination of the last episode of AG Flaring within the AG Flaring Incident.

Thus, for example, for AG Flaring within an AG Flaring Incident that (i) starts at 1:00 p.m. on Day 1 and ends at 1:30 p.m. on Day 1; (ii) recommences at 4:00 p.m. on Day 1 and ends at 4:30 p.m. on Day 1; (iii) recommences at 1:00 a.m. on Day 2 and ends at 1:30 a.m. on Day 2; and (iv) no further AG Flaring occurs within the AG Flaring Incident, the AG Flaring within the AG Flaring Incident shall be deemed to last 12.5 hours -- not 1.5 hours -- and the column for AG Flaring of "greater than 3 hours but less than or equal to 24 hours" shall apply.

(b.) For those corrective action(s) which Valero or Tesoro, as applicable, is required to undertake following Dispute Resolution (Part XXIII), then, from the date EPA notifies Valero or Tesoro, as applicable, of EPA's determination that corrective action, in addition to or distinct from any corrective action proposed by Valero or Tesoro, respectively, is required to respond to the Incident, reported under Paragraph 242, until the earlier of the following dates: (i) the date that a final agreement is reached between EPA and Valero or Tesoro, as applicable, regarding the corrective action; or (ii) the date that a court order regarding the corrective action is entered:

\$5,000 per month

(c.) Failure to complete any corrective action under Section XILE of this Decree in accordance with the schedule for such corrective action agreed to by Valero or Tesoro, as applicable, or imposed on Valero or Tesoro, as applicable, pursuant to the Dispute Resolution

provisions of Part XXIII of this Consent Decree provided (with any such extensions thereto as to which EPA and Valero or EPA and Tesoro may agree in writing):

\$5,000 per week

(d.) Failure to timely submit a report required by this Part XII, beginning on the seventh day past the report's due date:

\$5,000 per week, per report

(e.) For submitting any report that does not include the elements identified in Paragraph 242, beginning on the seventh day after Valero receives written notice from EPA of the deficiencies in such report and until corrected:

\$5,000 per week, per report

I. Certification

261. All notices, reports or any other submissions required of Valero or Tesoro by this Part XII shall contain the following certification:

"I certify under penalty of law that I have personally examined and am familiar with the information submitted herein and that I have made a diligent inquiry of those individuals immediately responsible for obtaining the information and that to the best of my knowledge and belief, the information submitted herewith is true, accurate, and complete. I am aware that there are significant penalties for submitting false information, including the possibility of fine and imprisonment."

262. Except as otherwise provided herein, the reporting requirements set forth in this Part XII do not relieve Valero or Tesoro of its obligation to any State, local authority, or EPA to

submit any other reports or information required by the CAA, or by any other state; federal or local requirements.

J. Flare Gas Recovery Systems

263. Periodic Maintenance of Flare Gas Recovery Systems. The Parties recognize that periodic maintenance may be required for properly designed and operated flare gas recovery systems. To the extent that Valero or Tesoro, as applicable, currently operates or will operate flare gas recovery systems, Valero or Tesoro, as applicable, will take all reasonable measures to minimize emissions while such periodic maintenance is being performed.

264. Safe Operation of Refining Processes. The Parties recognize that a flare gas recovery system may need to be bypassed in the event of an emergency, including unscheduled maintenance of such system in order to ensure continued safe operation of refinery processes. Nothing in this Consent Decree precludes Valero or Tesoro, as applicable, from temporarily bypassing a flare gas recovery system under such circumstances. To the extent that a Hydrocarbon Flaring Incident at Valero's Refineries or the Golden Eagle Refinery has as its Root Cause the bypass of a flare gas recovery system for safety or maintenance reasons as stated above, Valero or Tesoro, will be required only to describe the emergency or maintenance activity giving rise to the Hydrocarbon Flaring Incident, including an estimate of emissions, and to list the date, time, and duration of such Incident in the semiannual reports due under Part XVI

265. Commissioning. For the six (6) month period after the installation of a flare gas recovery system (that is, during the time in which the flare gas recovery system is being commissioned), Valero or Tesoro, as applicable, will not be required to undertake Hydrocarbon Flaring Incident investigations if the Root Cause of the Hydrocarbon Flaring Incident is directly

related to the commissioning of the flare gas recovery system and will not be required to take any further action.

266-267. Reserved

XIII. ST. CHARLES PROGRAM AND REFINERY AUDITS.

A. St. Charles Program

268. Notwithstanding anything to the contrary in Part(s) X, XI and/or XII, Valero may propose and EPA may permit the substitution of the activities completed, undertaken, and/or being implemented by Valero in accordance with the existing, BWN, LDAR and/or Flaring provisions, operated under the jurisdiction of LDEQ pursuant to the December 30, 2002 Orion-LDEQ Settlement Agreement, in whole or in part, in lieu of the requirements of Part X, XI and/or Part XII of this Consent Decree, as determined by EPA after an opportunity for consultation with LDEQ.

269. To the extent that, during the course of Valero and Tesoro's development of the Compliance Plans for Flaring Devices required under Section XII.C, Valero or Tesoro discovers information possibly demonstrating a failure by it to comply with the reporting requirements for continuous releases of SO_2 pursuant to Section 103(c) of CERCLA and/or Section 304 of EPCRA, including the regulations promulgated thereunder, a voluntary disclosure by Valero or Tesoro, as appropriate, of any such violations will not be deemed "untimely" under EPA's Audit Policy or any Plaintiff-Intervener's audit policy, solely on the ground that it submitted more than twenty-one (21) days after it is discovered, provided all such disclosures are made by no later than December 31, 2007.

B. NSPS 000 Audits

270. Valero and Tesoro, as applicable, may elect to perform an audit of compliance with the regulatory obligations of Subpart QQQ of the NSPS, promulgated at 40 C.F.R. Part 60, Subpart QQQ ("Subpart QQQ") at Tesoro Golden Eagle and/or one or more Valero refineries other than the Denver Refinery ("QQQ Audit"). Within ninety (90) days of the Date of Lodging, Valero and Tesoro, as applicable, shall notify EPA in writing which Refineries, if any, are electing to perform a QQQ Audit pursuant to this Section XIII.B..

271. QQQ Audits may cover all potential obligations from reporting years 1999 through Date of Entry of this Decree, including, but not limited to: (1) potential failures to make required applicability determinations; (2) potential failures to install proper control or monitoring equipment; (3) potential failures to undertake work practices; and (4) potential failures to submit accurate and/or timely reports.

272. The QQQ Audits may be performed by either an outside contractor or qualified internal staff. Valero or Tesoro may, where appropriate, consult with EPA regarding the scope of any of the proposed QQQ Audits. The QQQ Audits must be completed within one (1) year of notification under Paragraph 270.

273. For each Refinery electing to conduct a QQQ Audit, a final QQQ Audit report shall be submitted to EPA within thirty (30) days of completion of the QQQ Audit (the "QQQ Audit Report"). The QQQ Audit Report shall: describe the processes, procedures, and methodology used to conduct the audit; clearly identify any violations or potential violations of Subpart QQQ discovered at the Refinery through the QQQ Audit; describe any and all measures taken or to be

taken to correct the disclosed violations; and provide details concerning the costs associated with such corrective action(s) and economic benefit(s) obtained by such company.

274. Each QQQ Audit report shall be signed by an appropriate company official and the following certification shall directly precede such signature:

"I certify under penalty of law that I have personally examined and am familiar with the information submitted herein and that I have made a diligent inquiry of those individuals immediately responsible for obtaining the information and that to the best of my knowledge and belief, the information submitted herewith is true, accurate and complete. I am aware that there are significant penalties for submitting false information, including the possibility of fine and imprisonment."

275. Violations and potential violations reported in a QQQ Audit and corrected by the date of the QQQ Audit Report or such other reasonable additional time as EPA allows shall be deemed to satisfy the requirements of EPA's Audit Policy. Once EPA has made the determination that a QQQ Audit conducted by Valero or Tesoro was consistent with the requirements of this Section XIII.B, EPA will notify Valero or Tesoro, as applicable, in writing. Valero or Tesoro, as applicable, shall thereupon be released from liability for any claims for civil and administrative penalties with respect to all violations or potential violations disclosed and corrected in accordance with this Part XIII, and contained in EPA's notification.

276. For each Refinery that undertakes a QQQ Audit, Valero or Tesoro, as applicable, shall pay a stipulated penalty of \$50,000, in total, for each such Refinery covering any and all disclosed violations, but if EPA determines that the economic benefit of non-compliance exceeds

\$25,000, Valero or Tesoro, as applicable, shall pay an additional stipulated penalty equal to the difference between such economic benefit and \$25,000.

277. Reserved

C. Refinery MACT I Audits

278: Valero and Tesoro, as applicable, may elect to perform an audit of compliance with the regulatory obligations of 40 C.F.R. Part 63, Subpart CC promulgated at 40 C.F.R Section 63.640 et seq., (the "Refinery MACT I") at one or more Valero Refineries (excluding only the Paulsboro Refinery) or at Tesoro's Golden Eagle Refinery ("MACT Audit"). Within ninety (90) days of the Date of Lodging, Valero and Tesoro, as applicable, shall notify EPA in writing which Refineries, if any, are electing to perform a MACT Audit pursuant to this Section XIII.C.

279. MACT Audits may cover all potential obligations from reporting years 1999 through Date of Entry of this Decree. Reporting obligations under MACT CC may include, but are not limited to: (1) potential failures to make required applicability determinations; (2) potential failures to install proper control or monitoring equipment; (3) potential failures to undertake work practices; and (4) potential failures to submit accurate and/or timely reports.

280. The MACT Audits may be performed by either an outside contractor or qualified internal staff. Valero or Tesoro may, where appropriate, consult with EPA regarding the scope of any of the proposed MACT Audits. The MACT Audits must be completed by no later than one year of notification under Paragraph 278.

281. For each Refinery electing to conduct a MACT Audit, a final MACT Audit Report shall be submitted to EPA within 30 days of completion of the MACT Audit. The MACT Audit Report shall describe the processes, procedures, and methodology used to conduct the audit;

clearly identify any violations or potential violations of Refinery MACT I discovered at the Refinery through the MACT Audit; describe any and all measures taken to correct the disclosed violations; and provide details concerning the costs associated with such corrective action(s) and economic benefit(s) obtained by such company.

282. Each MACT Audit Report shall be signed by an appropriate company official and the following certification shall directly precede such signature:

"I certify under penalty of law that I have personally examined and am familiar with the information submitted herein and that I have made a diligent inquiry of those individuals immediately responsible for obtaining the information and that to the best of my knowledge and belief, the information submitted herewith is true, accurate, and complete. I am aware that there are significant penalties for submitting false information, including the possibility of fine and imprisonment."

283. Violations and potential violations reported in a MACT Audit Report and corrected by the date of the MACT Audit Report or such other reasonable additional time as EPA allows shall be deemed to satisfy the requirements of EPA's Audit Policy. Once EPA has made the determination that a MACT Audit conducted by Valero or Tesoro was consistent with the requirements of this Section XIII.C, EPA will notify Valero or Tesoro, as applicable, in writing. Valero or Tesoro, as applicable, shall thereupon be released from liability for any claims for civil and administrative penalties with respect to all violations or potential violations disclosed and corrected in accordance with this Part XIII, and contained in EPA's notification.

284. For each Refinery that undertakes a MACT I Audit, Valero or Tesoro, as applicable, shall pay a stipulated penalty of \$50,000, in total, for such Refinery covering any and

Handwritten signature or initials, possibly "RJA", in black ink.

all disclosed violations, but if EPA determines that the economic benefit of its non-compliance exceeds \$25,000, Valero or Tesoro, as applicable, shall also pay an additional stipulated penalty equal to the difference between such economic benefit and \$25,000.

D. Mobile Source Program

285. To increase awareness of obligations to comply with federal and state mobile source regulations, Valero shall form a Clean Fuels Implementation Team ("CFIT") consisting of representatives from each affected organization consistent with the charter for the CFIT outlining current roles and responsibilities and membership attached to Appendix R. Valero shall maintain the CFIT for the duration of this Consent Decree. Within sixty days following the first full calendar quarter after the Date of Entry of the Consent Decree and annually, on or before February 28 of each year for the period between January 1 and December 31 of the preceding calendar year, Valero shall submit to EPA a status report confirming the establishment and operation of the CFIT.

XIV. PERMITTING

286. Construction. Valero agrees to apply for and make all reasonable efforts to obtain in a timely manner all appropriate federally enforceable permits (or construction permit waivers) for the construction of the pollution control technology required to meet the above pollution reductions at Valero's Refineries. Tesoro agrees to apply for and make all reasonable efforts to obtain in a timely manner all appropriate federally enforceable permits (or construction permit waivers) for the construction of the pollution control technology required to meet the above pollution reductions at the Golden Eagle Refinery. For purposes of the PSD and New Source Review ("NSR") non-attainment regulations, any source subject to an optimization study or

demonstration period pursuant to this Consent Decree, whether involving the construction of control equipment or utilization of catalyst additives, will not be deemed to have "commenced operation" as a modified source including such control technology or catalyst additive until after the optimization study or demonstration period, as applicable, is completed and applicable emission limitations are established for such source in accordance with this Consent Decree. Nothing in this paragraph constitutes a determination by the United States or any Plaintiff-Intervener hereto, nor any admission by Valero or Tesoro, that any permit is required prior to the installation or operation of any equipment installed pursuant to this Consent Decree.

287. In submitting to the appropriate permitting authority an application for an air quality permit governing any emission control measure identified in this Consent Decree, Valero or Tesoro, as applicable, may include in its permit application any contemporaneous changes associated with a single project. The calculation of the emission increase or decrease attributed to the project shall apply the following criteria:

- (a.) The "baseline" emission rate used for the project shall reflect emissions of the relevant criteria pollutants prior to project implementation and shall not reflect projected emission reductions from any emission control measures identified in this Consent Decree prior to the date that such emission control measures are required or installed pursuant to this Consent Decree, whichever date is earlier (the "Pre-Project Baseline Emission Rate");
- (b.) The projected emission rate attributable to the project following completion of the project governed by the permit application shall be based upon the net emission increase or decrease resulting from all contemporaneous changes that are part of a



single project and that are reflected in the permit application (the "Post-Project Projected Emission Rate"); and

- (c.) Both the Pre-Project Baseline Emission Rate and the Post-Project Projected Emission Rate shall otherwise be determined, and the resulting net emission increase otherwise calculated, in accordance with relevant regulations applicable at the time of permit application submittal.

288. In the event that any provision of this Consent Decree provides for imposition upon an emission unit of any emission limitation, either through the Consent Decree or any air quality permit to be issued in accordance with the terms of the Consent Decree, the compliance of the emission unit with the relevant emission limitation shall be determined based only on emissions from the source subsequent to the effective date of the emission limitation.

289 - 290. Reserved.

291. Obtaining Permit Limits for Consent Decree Emission Limits and Standards That Are Effective Upon Entry. By no later than December 31, 2005, Valero or Tesoro, as appropriate, shall submit applications to the appropriate permitting authority to incorporate the emission limits and standards required by the Consent Decree that are effective as of the Date of Entry of the Consent Decree into federally enforceable minor or major new source review permits or other permits (other than Title V permits) which are federally enforceable. Following submission of the permit application, Valero or Tesoro, as appropriate, shall cooperate with the appropriate permitting authority by promptly submitting all information that such permitting authority seeks following its receipt of the permit application. Upon issuance of such permits or in conjunction with such permitting, Valero or Tesoro, as appropriate, shall file any applications

necessary to incorporate the requirements of those permits into the Title V permit for the relevant refinery. Nothing in this Consent Decree is intended nor shall it be construed to require the establishment of emission limits (e.g. pounds per hour or tons per year) other than those concentration or rate based limits expressly prescribed in this Consent Decree.

292. Obtaining Permit Limits For Consent Decree Emission Limits That Become Effective After Date of Entry. As soon as practicable, but in no event later than ninety (90) days after the effective date or establishment of any emission limits and standards required by or under this Consent Decree, Valero or Tesoro, as appropriate, shall submit applications to the appropriate permitting authority to incorporate those emission limits and standards into federally enforceable minor or major new source review permits or other permits (other than Title V permits) which are federally enforceable. Following submission of the permit application, Valero or Tesoro, as appropriate, shall cooperate with the appropriate permitting authority by promptly submitting all information that such permitting authority seeks following its receipt of the permit application. Upon issuance of such permit or in conjunction with such permitting, Valero or Tesoro, as appropriate, shall file any applications necessary to incorporate the requirements of that permit into the Title V permit of the appropriate refinery.

293. Mechanism for Title V Incorporation. The Parties agree that the incorporation of any emission limits or other standards into the Title V permits for the Valero or Tesoro Refineries, as required Paragraph 291 and 292, shall be in accordance with the applicable state or local Title V rules.

294. This Consent Decree is not intended to require the continued use of a particular control technology past the compliance dates established in this Consent Decree. The parties

agree that once the concentration based permit limits are established using the methodology provided for in the Consent Decree, Valero or Tesoro, as applicable, may elect to comply with that concentration based permit limit through other control technology methods. Nothing here relieves Valero or Tesoro, as applicable, from obtaining any appropriate state permits or authorizations to switch to such other control technology or methods.

XV. EMISSION REDUCTION CREDITS

295. This Part sets forth the exclusive process for Valero or Tesoro, as applicable, to use any NO_x or SO₂ emission reductions required by this Consent Decree as emission reduction credits for PSD netting or major nonattainment New Source Review ("NSR") offsets, or in any minor NSR permit or permit proceeding where such credits or offsets are relied upon to avoid PSD or major nonattainment NSR permitting. Except as provided in this Part, Valero and Tesoro will neither generate nor use any NO_x or SO₂ emission reductions resulting from any projects conducted pursuant to this Consent Decree as emission reduction credits or offsets in any PSD, major nonattainment and/or minor NSR permit or permit proceeding ("NSR Permit" or "NSR Permitting").

296. Outside the Scope of Prohibition. Nothing in this Consent Decree is intended to prohibit Valero or Tesoro, as applicable, from:

- (a.) utilizing or generating netting reductions or emission offset credits from refinery units that are covered by this Consent Decree to the extent that the proposed netting reductions or emission offset credits represent the difference between the emissions limitations set forth in or used to meet the terms of this Consent Decree for these refinery units and the more stringent emissions limitations that Valero or

Tesoro, as applicable, may elect to accept for these refinery units in NSR Permitting;

- (b) utilizing or generating netting reductions or emission offset credits for refinery units that are not subject to an emission limitation pursuant to this Consent Decree;
- (c) utilizing emission reductions from the installation of controls required by this Consent Decree in determining whether a project that includes both the installation of controls under this Consent Decree and other construction occurring at the same time and that is permitted as a single project, triggers NSR Permitting; and
- (d) utilizing or generating emission reductions for a particular Refinery's compliance with any rules or regulations designed to address regional haze, state specific air quality issues, or the non-attainment status of any area (excluding NSR Permitting, but specifically including, NOx or VOC RACT Rules, BAAQMD IERC Program, RECLAIM, the Northeast Ozone Transport Region NOx Budget Program, and the Houston/Galveston Area NOx SIP, and other such programs) that apply to the particular Refinery. Notwithstanding the preceding sentence, and except as between the Houston Refinery and the Texas City Refinery (for which trading as between the two refineries is allowed under the SIP), Valero or

Tesoro, as applicable, will not trade or sell any emissions reductions to another refinery or plant.

A. Generating NO_x and SO₂ Emission Credits

296A. For purposes of this Consent Decree, emissions credits for PSD netting and Nonattainment NSR offsets may be applied and used only at the refinery where they were generated.

297. Emission reduction credits generated by each unit shall be determined in accordance with the PSD/Nonattainment NSR regulations applicable to the relevant facility at the time the reductions are proposed to be generated. The quantity of emission reduction credits shall be calculated as the difference between such unit's baseline emissions and its applicable emissions at the time the emission reductions are proposed to be used for netting or are generated for offset purposes, as limited by the percentages expressed and the limitations on use set forth in Paragraphs 299 and 300.

298. To apply or use emission reduction credits under this Part, Valero or Tesoro, as applicable, must make any such emission reductions federally enforceable. Such emission reductions are creditable for five years from their date of generation and shall survive termination of the Consent Decree.

B. Using NO_x and SO₂ Emission Credits and Offsets

299. Subject to Paragraph 305, Valero or Tesoro, as applicable, may use, without further restriction or limitation up to five percent (5%) of the NO_x emission reductions achieved through its compliance with Part IV of this Consent Decree as emission reduction credits for netting and/or offsets in any NSR Permit after the Date of Entry of this Consent Decree; provided,

however, that Valero or Tesoro, as applicable, may use such NO_x emission reductions for netting or offset proposes only at a new or modified heater or boiler that is designed to achieve an emission rate of 0.020 lbs NO_x per million BTU (even if the burners do not achieve that emission rate in practice and a less stringent emission limit is therefore warranted). Valero or Tesoro, as applicable, may use up to an additional five percent (5%) of the NO_x emission reductions achieved through its compliance with Part IV of this Consent Decree as emission reduction credits for netting and/or offsets in any PSD, Nonattainment NSR and/or minor NSR permit or permit proceeding after the Date of Entry of this Consent Decree only at a new or modified heater or boiler that is designed to achieve an emission rate of 0.020 lbs NO_x per million BTU (even if the burners do not achieve that emission rate in practice and a less stringent emission limit is therefore warranted) and that is constructed or modified for purposes of compliance with Clean Fuels requirements. For purposes of this Consent Decree, a "Clean Fuels" requirement includes Tier II Gasoline, Low or Ultra Low Sulfur Diesel, ether based oxygenate replacement (but only to the extent such replacement is demonstrated by Valero), California Fuels or other specialty fuels identified in or required under any SIP.

300. Subject to Paragraph 305, Valero or Tesoro, as applicable, may use, without further restriction or limitation, up to five percent (5%) of the SO₂ emission reductions achieved through compliance with this Consent Decree as emission reduction credits for netting and/or offsets in any NSR Permit after the Date of Entry of this Consent Decree, provided, however, that such new or modified unit for purposes of compliance with Clean Fuels requirements and that such or modified source meets the definition of a "Netting Unit" under Paragraph 301. Valero or Tesoro, as applicable, may use up to an additional five percent (5%) of the SO₂ emission



reductions achieved through its compliance with this Consent Decree as emission reduction credits for netting and/or offsets in any NSR Permit after the Date of Entry of this Consent Decree only to the extent that such emission reductions were generated by a "Netting Unit" and will be used for a new or modified source that meets the definition of a "Netting Unit."

301. For purposes of this Part XV, Netting Units shall be defined as follows:

- (a.) Any FCCU that achieves an SO₂ concentration of 25 ppmvd on a 365-day rolling average basis, at 0% oxygen, or such other emission limit as may be established by EPA based upon a percentage reduction in SO₂ emissions, as specifically authorized in Part VI of this Consent Decree;
- (b.) The Benicia Fluid Coker, following installation and initial operation of a scrubber or similar technology, as addressed in Paragraph 67 of this Consent Decree;
- (c.) Heaters and boilers that either combust fuel gas containing less than 0.1 grams of hydrogen sulfide per dry standard cubic foot of fuel gas or emit SO₂ at less than 20 ppmvd at 0% oxygen, both on a 3-hour rolling average basis; and
- (d.) An SRP that complies with relevant provisions of 40 C.F.R. Part 60, Subpart J.

302. Valero and Tesoro will submit to EPA annual reports regarding the generation and use of emission reduction credits under this Part XV. The first such report will be submitted by January 31, 2006. Successive reports will be submitted on January 31 of each subsequent year for the duration of this Consent Decree. Each such report shall contain the following information for each Valero Refinery or the Golden Eagle Refinery, as applicable, to the extent that emission reduction credits are both generated at such refinery and are limited by this Part:

(a.) The quantity of credits generated since the Date of Entry of this Consent Decree and the emission unit(s) generating such credits, the date on which those credits were generated, and the basis for those determinations;

(b.) The quantity of credits used since the Date of Entry of this Consent Decree and the emission units to which those credits were applied;

(c.) To the extent known at the time the report is submitted, the additional units to which credits will be applied in the future and the estimated amount of such credits that will be used for each such unit; and

(d.) To the extent Valero or Tesoro, as applicable, will seek to use the additional five percent (5%) of NO_x credits provided for in the second sentence in Paragraph 299 and/or the five percent (5%) of SO₂ credits provided for in the first sentence in Paragraph 300, the date by which Clean Fuels are expected to be produced at that Facility and a detailed explanation of why such unit(s) is (are) necessary for the production of Clean Fuels.

303. The provisions of this Part are intended to restrict the quantity of SO₂ and NO_x emission reduction credits that may be generated by Valero and Tesoro as a result of the emission reductions specifically required by this Consent Decree for use in any netting and/or offsets in any NSR Permit after the Date of Entry of this Consent Decree. In addition, the provisions of this Part restrict the use of certain SO₂ and NO_x emission reduction credits authorized for generation under this Consent Decree to projects necessary to the production of Clean Fuels, as defined and the manner described in this Consent Decree.

304. Without limitation to the foregoing, nothing this Consent Decree is intended to contravene, impair, be inconsistent with or otherwise restrict compliance options available to



Valero or Tesoro under any SIP to demonstrate compliance with any emission limitation or other standard applicable to Valero's Refineries or the Golden Eagle Refinery, including without limitation any provision established or imposed under an applicable SIP governing intra-facility emission trading.

305. Nothing in this Part XV shall affect the validity of permits issued or permit applications made prior to the Date of Lodging, including any contemporaneous netting analyses in such permits and/or applications. The following shall apply to all such permits and permit applications:

(a) Emission reduction credits and/or offsets used by or for units that were permitted, constructed/modified and began operation before March 31, 2005, shall not affect the amount of credits and/or offsets available for Valero's use under Paragraphs 299 and 300.

(b) Emission reduction credits and/or offsets used by or for units that were permitted but did not begin operation before March 31, 2005 (i.e. Houston Permit Nos. 71281 and 2507A), shall not affect the amount of credits and/or offsets available for Valero's use under Paragraphs 299 and 300.

(c) Emission reduction credits and/or offsets used by or for units that were not permitted before March 31, 2005 (e.g., St. Charles permit 2909-VO), shall affect the amount of credits and/or offsets available for Valero's use under Paragraphs 299 and 300.

For purposes of Paragraph 305(c), the effect of such emission reduction credits and/or offsets shall be to reduce the amount of credits and/or offsets available for Valero's use under Paragraphs 299 and 300 as applicable to such Refinery. Such reduction of available credits and/or offsets will be for non-Clean Fuels projects and/or for Clean Fuels projects, as

appropriate. If such reductions exceed the amount available under Paragraphs 299 and/or 300, the amount available for Valero's use under these paragraphs shall be 0.0. For example, if a refinery generates 500 tons of SO₂ emissions reduction credits through compliance with the Consent Decree, it would have 50 tons available for use under Paragraph 300 [5% of 500 tons for general projects plus 5% of 500 tons for Clean Fuels projects]. If 30 tons of reductions were used in the existing permitting actions for a Clean Fuels project, such refinery would have 0 tons of available credits to use for Clean Fuels projects and 20 tons available for general projects under Paragraph 300 of the Consent Decree; but if 70 tons of reductions were so used, such refinery would have 0 tons of credits available under Paragraph 300.

306. Reserved.

XVI. GENERAL RECORDKEEPING, RECORD RETENTION AND REPORTING

307. Valero and Tesoro, as applicable, shall retain all records required to be maintained in accordance with this Consent Decree for a period of five (5) years or until Termination, whichever is longer, unless applicable regulations require the records to be maintained longer.

308. Following the first full calendar quarter after the Date of Entry of the Consent Decree, Valero and Tesoro shall each submit to EPA, within thirty (30) days after the end of such calendar quarter, and semiannually thereafter during the life of this Consent Decree a progress report ("Progress Report") covering each refinery owned and operated by Valero or Tesoro, as applicable. Each Progress Report shall be certified in accordance with Paragraph 309 and shall contain, for each such refinery, as applicable, the following:

- (a.) progress report on the implementation of the requirements of Parts IV through XII of this Consent Decree;



- (b.) a summary of emissions data that is specifically required by Parts IV through XII of this Consent Decree for the calendar quarter;
- (c.) a description of any problems anticipated with respect to meeting the compliance programs of Parts IV through XII of this Consent Decree;
- (d.) a description of implementation activity for all environmentally beneficial projects; and
- (e.) any such additional matters as Valero or Tesoro, as applicable, believes should be brought to the attention of the United States, EPA and/or the appropriate Plaintiff-Intervener.

309. To the extent that any provision of this Consent Decree specifically requires that any notice, report or other submission must be certified, such submissions shall contain the following certification. Such certification may be signed by the refinery manager or his/her designee, as provided in writing by the refinery manager, provided the designee is a company employee with responsibilities related to environmental management or compliance.

I certify under penalty of law that this information was prepared under my direction or supervision in accordance with a system designed to ensure that qualified personnel properly gather and evaluate the information submitted. Based on my directions and my inquiry of the person(s) who manage the system, or the person(s) directly responsible for gathering the information, the information submitted is, to the best of my knowledge and belief, true, accurate, and complete."

XVII. PENALTY

310. Within thirty(30) calendar days of the Date of Entry, Valero, on behalf of itself and Tesoro, shall pay a civil penalty, in the aggregate, of \$5,500,000 as follows: (i) \$3,400,000 to the United States; (ii) \$600,000 to Plaintiff-Intervener, the State of New Jersey, inclusive of \$446,000 of the penalty paid by Valero under EA ID# NEA030001-55829; (iii) \$175,000 to Plaintiff-Intervener the State of Louisiana; (iv) \$75,000 to Plaintiff-Intervener the State of Oklahoma; and (v) \$1,250,000 to Plaintiff-Intervener, the State of Texas.

311. Valero's payment of civil penalty monies to the United States shall be made by Electronic Funds Transfer ("EFT") to the United States Department of Justice, in accordance with current EFT procedures, referencing the USAO File No. and DOJ Case Number 90-5-2-1-0681111, and the civil action case name and case number of the United States District Court for the Western District of Texas. The costs of such EFT shall be Valero's responsibility. Payment shall be made in accordance with instructions provided to Valero by the Financial Litigation Unit of the U.S. Attorney's office for the Western District of Texas. Any funds received after 11:00 a.m. (est) shall be credited on the next business day. Valero shall provide notice of payment, referencing the USAO File No. and DOJ Case Number, and the civil action case name and case number to the Department of Justice and to EPA, as provided in Paragraph 376 (Notice).

312. Valero's payment of civil penalty monies to the State of New Jersey shall be made by corporate check made payable to "Treasurer, the State of New Jersey" and delivered to

Administrator, Air Compliance & Enforcement
New Jersey Department of Environmental Protection
PO Box 422
Trenton, NJ 08625-0422

312A. Valero's payment of civil penalty monies to the State of Louisiana shall be made by corporate check made payable to the Louisiana Department of Environmental Quality and delivered to

Darryl Serio, Fiscal Director
Office of Management and Finance, LDEQ
PO Box 4303
Baton Rouge, LA 70821-4303

312B. Valero's payment of civil penalty monies to the State of Texas shall be made by corporate check made payable to the "State of Texas" and delivered to the attorneys for the State of Texas:

Office of the Attorney General of the State of Texas
Natural Resource Division, Attn: Karen Komell
300 West 15th Street, 10th Floor,
Austin, Texas 78701 or,
P.O. Box 12548
Austin, Texas 78871-2548, and marked with AG No. 042019604.

312C. Valero's payment of civil penalty monies to the State of Oklahoma shall be made by corporate check made payable to the "Department of Environmental Quality Revolving Fund" and delivered to:

Oklahoma Department of Environmental Quality
Finance and Human Resources Management
ATTN: Accounts Receivable
PO Box 2036
Oklahoma City, OK 73101

314. Upon the Date of Entry, this Consent Decree shall constitute an enforceable judgment for purposes of post-judgment collection in accordance with Rule 69 of the Federal Rules of Civil Procedure, the Federal Debt Collection Procedure Act, 28 U.S.C. § 3001-3308, and other applicable federal authority. The United States and the Plaintiff-Intervenors shall be

deemed judgment creditors for purposes of collection of any unpaid amounts of the civil and stipulated penalties and interest.

315. No amount of the civil penalty to be paid by Valero or Tesoro shall be used to reduce its federal or state tax obligations.

XVIII. RESERVED

XIX. SUPPLEMENTAL/BENEFICIAL ENVIRONMENTAL PROJECTS

A. Facility/Community-Specific Supplemental/Beneficial Environmental Projects

316. Valero shall spend no less than \$3,000,000 to implement the following projects:

a. Paulsboro Separator Cover: Valero shall spend no less than \$1,000,000 to install a cover for the Paulsboro Refinery wastewater plant separator cover in accordance with the criteria, requirements and schedule reflected in NJDEP Order under EA 10#NEA030001-55829 (e.g., collected VOCs to be vented to a VOC emission control device with a demonstrated VOC removal efficiency of at least 95%).

b. Comus Christi West HDS Off Gas Compressor: Valero shall spend no less than \$1,000,000 to install a redundant Hydrodesulfurization unit (HDS) Off Gas Compressor and related equipment. The redundant new compressor will split load with the existing compressor to improve reliability and will also be capable of taking the entire load when the existing compressor is down for maintenance or due to a malfunction. The project will be completed by December 31, 2006, and include a compressor and motor driver, four interstage air-cooled heat exchangers, a suction drum and four knockout drums, a lube oil system, control panel and Bentley Nevada conditioning monitoring equipment.

Environmental/Community Benefit: Completion of this project will reduce the likelihood of a HDS off gas flaring event and will significantly the reduce the duration of any event should it occur. Valero estimates it could avoid the release of 50,000-75,000 lbs of SO₂ emissions annually.

c. Corpus Christi East Refinery Benzene Reduction Project: Valero shall spend no less than \$500,000 to replace inefficient single seal pump seals with dual seals and/or routing any seal leakage to a control device. This project will be completed by no later than December 31, 2006.

Environmental Benefit: This project will eliminate or significantly reduce the potential for fugitive emissions of volatile organic compounds, particularly benzene, from being released.

d. Denver Refinery Schools Project: Valero shall implement a supplemental environmental project (SEP) by transferring \$500,000 to Colorado's Office of Energy Management and Conservation (OEM) within ninety (90) days of the Date of Entry for the sole purpose of assessing and implementing energy efficiency measures and renewable energy technologies on schools in the Commerce City and/or Northeast Denver Metro Area (Denver Public Schools and Adams County). It is expressly understood by the Parties that this transfer will be conditioned upon the following:

i. OEM shall give priority consideration to schools in close proximity to the Denver Refinery and will utilize no more than twenty thousand dollars (\$20,000) for each school to conduct energy efficiency assessments, utilizing existing assessments to the extent practicable;

ii. Based upon the assessments, OEM shall select schools and allocate monies to install renewable energy and implement energy efficiency measures within such selected schools to achieve the greatest environmental benefits while also ensuring that these funds will be allocated to both Denver Public Schools and Adams County Public Schools to the extent practicable;

iii. OEM shall leverage funds to the greatest extent practicable to achieve the greatest reduction of energy use by working through existing programs (e.g., Rebuild Colorado which has seen a 5:1 leveraged ratio);

iv. OEM shall report on the outcomes resulting from the projects on an annual basis for a period of five years (outcome measures will include, energy use reduction, water use reduction, cost savings, and other environmental benefits, including emission reductions attributable to such project);

v. OEM shall utilize no more than ten thousand dollars (\$10,000.00) to work with all participating schools to provide education to their employees, students and communities regarding the projects and resultant benefits; and

vi. OEM shall complete the assessments and implementation of identified energy efficiency measures and renewable energy technologies at the selected schools by no later than December 31, 2008.

B. Truck and Vehicle Emission Reduction SEPs

317. a. Valero shall spend no less than \$1,900,000 to implement SEPs designed to reduce emissions from in-service fleet vehicles, including enhancement of the availability of ultra low-sulfur diesel fuel ("ULSD") for such fleets, and other vehicles in accordance with the

requirements of this Paragraph 317.a and the criteria, terms and procedures specified in

Appendix P. The above amount shall be allocated as follows:

- i. Valero shall spend no less than \$200,000 to implement Truck and Vehicle Emission Reduction SEPs in the general area where its Benicia Refinery is located.
- ii. Valero shall spend no less than \$300,000 to implement Truck and Vehicle Emission Reduction SEPs in the general area where its Corpus Christi (East) and Corpus Christi (West) Refineries are located.
- iii. Valero shall spend no less than \$300,000 to implement Truck and Vehicle Emission Reduction SEPs in the general area where its Houston Refinery is located.
- iv. Valero shall spend no less than \$200,000 to implement Truck and Vehicle Emission Reduction SEPs in the general area where its McKee Refinery is located.
- v. Valero shall spend no less than \$200,000 to implement Truck and Vehicle Emission Reduction SEPs in the general area where its Denver Refinery is located.
- vi. Valero shall spend no less than \$300,000 to implement Truck and Vehicle Emission Reduction SEPs in the general area where its Texas City Refinery is located.
- vii. Valero shall spend no less than \$200,000 to implement Truck and Vehicle Emission Reduction SEPs in the general area where its Three Rivers Refinery is located.
- viii. Valero shall spend no less than \$200,000 to implement Truck and Vehicle Emission Reduction SEPs in the general area where its Wilmington Refinery is located.

By no later than December 31, 2006, Valero shall submit a Statement of Work ("SOW") for each Truck and Vehicle Emission Reduction SEP that it proposes to perform, which shall include a description of how the SEP meets the criteria in Appendix P, a schedule for development and

implementation and its estimated cost. Each SOW shall be subject to approval by EPA, after an opportunity for consultation with appropriate state and local authorities. Valero shall complete implementation of all SEPs and each approved SOW by no later than June 30, 2010.

b. Valero shall spend no less than \$600,000 to implement SEPs designed to reduce emissions from in-service fleet vehicles, including enhancement of the availability of ultra-low-sulfur diesel fuel ("ULSD") for such fleets, in accordance with the requirements of this Paragraph 317.b. The above amount shall be allocated as follows:

1. Valero shall spend no less than \$200,000 on truck and vehicle emission reduction SEPs to be implemented in the general area where its Ardmore Refinery is located.

These projects are to be determined jointly by Valero and the State of Oklahoma, in consultation with EPA and in consideration of the criteria specified in Appendix P.

ii. Valero shall spend no less than \$200,000 on truck and vehicle emission reduction SEPs to be implemented in the general area where its Krotz Springs and St. Charles Refineries are located. These projects are to be determined jointly by Valero and the State of Louisiana, in consultation with EPA and in consideration of criteria specified in Appendix P.

iii. Valero shall spend \$200,000 on truck and vehicle emission reduction SEPs to be implemented in the general area where its Paulsboro Refinery is located. These projects are to be determined jointly by Valero and the State of New Jersey, in consultation with EPA and in consideration of the criteria specified in Appendix P.

iv. If Valero demonstrates to the appropriate Plaintiff-Intervener and to EPA prior to or upon submission of its SOW(s) that it cannot identify appropriate State truck and

Handwritten signature or initials in black ink, possibly reading "DP".

vehicle emission reduction SEPs in the amount required by this Paragraph 317.b, Valero may seek approval from the appropriate Plaintiff-Intervener, after an opportunity for consultation with EPA, to submit and implement one or more alternative SEPs that will achieve equivalent or greater environmental benefits in the general area around the relevant Refinery. In addition and should Valero fail to spend the required amounts identified for a project referenced in subparagraph i, ii or iii, above, the difference between the amount spent and the amount required may be applied to other SEP projects that are approved and implemented under this subparagraph 317.b.iv.

By no later than December 31, 2006 or as permitted under subparagraph 317.b.iv, Valero shall submit a SOW for each State truck and vehicle emission reduction SEP that it proposes to perform, including a schedule for development and implementation, and its estimated cost. Each SOW shall be subject to approval by the appropriate Plaintiff-Intervener, after an opportunity for comment by EPA. Valero shall complete implementation of all SEPs and each approved SOW by no later than December 31, 2009.

C. General Project Requirements

318. a. Valero is responsible for the satisfactory completion of the projects required under this Consent Decree in accordance with this Part XIX. Upon completion of each project set forth in Paragraphs 316 and 317, Valero will submit to EPA and the applicable Plaintiff-Intervener a cost report certified as accurate under penalty of perjury by a responsible corporate official. If Valero does not expend the project-specific amounts required under Paragraphs 316 and/or 317, Valero will pay a stipulated penalty equal to the difference between the amount expended (as demonstrated in the certified cost report(s)) and such project-specific

Handwritten signature or initials in black ink, possibly reading 'D. J. ...'.

required amount. The stipulated penalty will be paid as provided in Paragraph 321 (Payment of Stipulated Penalties).

b. By signing this Consent Decree and except with respect to Paragraph 316.a, Valero certifies that it is not required, and has no liability under any federal, state, regional or local law or regulation or pursuant to any agreements or orders of any court, to perform or develop any of the projects identified in this Part XIX. Valero further certifies that it has not applied for or received, and will not in the future apply for or receive: (1) credit as a Supplemental Environmental Project or other penalty offset in any other enforcement action for the projects set forth in this part, except with respect to Paragraph 316.a; (2) credit for any emissions reductions resulting from the projects set forth in this part in any federal, state, regional or local emissions trading or early reduction program; or (3) a deduction from any federal, state, regional, or local tax based on its participation in, performance of, or incurrence of costs related to the projects set forth in this part.

c. Valero will include in each report required by Paragraph 308 a description of its progress under this Part XIX. In addition, the report required by Paragraph 308 of this Consent Decree for the period in which each project identified in Paragraphs 316 and/or 317 is completed will contain the following information with respect to such project(s):

- i. A detailed description of each project as implemented;
- ii. A brief description of any significant operating problems encountered, including any that had an impact on the environment, and the solutions for each problem;
- iii. Certification that each project has been fully implemented pursuant to the provisions of this Consent Decree; and



iv. A description of the environmental and public health benefits resulting from implementation of each project (including quantification of the benefits and pollutant reductions, if feasible).

d. Valero agrees that it must clearly indicate that these projects are being undertaken as part of the settlement of an enforcement action for alleged violations of the Clean Air Act and corollary state statutes in any public statements regarding these projects.

XX. STIPULATED PENALTIES

319. Valero or Tesoro, as applicable, shall pay stipulated penalties to the United States or the appropriate Plaintiff-Intervener, where appropriate, for each failure by such company to comply with the terms of this Consent Decree; provided, however, that the United States or the appropriate Plaintiff-Intervener may elect to bring an action for contempt in lieu of seeking stipulated penalties for violations of this Consent Decree. Valero and Tesoro shall be separately, and not jointly and severally, liable for any stipulated penalties under this Part for violations of this Consent Decree by Valero or Tesoro, respectively. For each violation, the amounts identified below shall apply on the first day of violation and shall be calculated for each incremental period of violation (or portion thereof). Stipulated penalties under subparagraphs 320(d) and 320(e) shall not start to accrue unless and until there is noncompliance with the concentration-based, rolling average emission limits identified in those paragraphs for 5% or more of the applicable unit's operating time during any calendar quarter. For those provisions where a stipulated penalty of either a fixed amount or 1.2 times the reasonable economic benefit of Valero's or Tesoro's delayed compliance is specifically identified below as available, the decision of which alternative to seek shall rest exclusively with the discretion of the United

States and the appropriate Plaintiff-Intervener. In no event shall any penalty assessed against Valero or Tesoro exceed the maximum civil penalty that may be assessed under the Clean Air Act 42 U.S.C § 7413 for any individual violation of this Consent Decree.

320. The following provisions are not intended, nor shall be construed, to be duplicative. Instead, any action or omission by Valero or Tesoro, respectively, that constitutes noncompliance this Consent Decree shall give rise to a single stipulated penalty, hereunder, assessable to either Valero or Tesoro, as appropriate, except to the extent that any stipulated penalty provision specifically provides for additional penalties for continuing violations.

(a.) Requirements for NOx emission reductions from Covered Heaters and Boilers (Part IV):

- i.) Failure to achieve the interim emission reduction goals in accordance with Section IV.B: \$100,000 per quarter.
- ii.) Failure to achieve the final emission reduction goals in accordance with Section IV.C or IV.G: \$200,000 per quarter.

(b.) Failure to submit any written deliverable required under this Consent Decree:

Period of Delay	Penalty per Day
1 st day through 30 th day after deadline	\$200
31 st day through 60 th day after deadline	\$500
Beyond 60 th day after deadline	\$1,000

(c.) Failure to conduct any performance test, to install, calibrate and operate a CEMS or COMS or to establish PEMS operating parameters in accordance with Appendix S:

Period of Delay	Penalty per Day
1 st day through 30 th day after deadline	\$500

31 st day through 60 th day after deadline	\$1,000
Beyond 60 th day after deadline	\$2,000 or an amount equal to 1.2 times the economic benefit of delayed compliance, whichever is greater.

(d) Requirements for NO_x emission reduction from FCCDs (Part V):

Failure to meet emission limits established pursuant to Part V: \$750 for each calendar day in a calendar quarter on which the specified 7-day rolling average exceeds the applicable limit; \$2,500 for each calendar day in a calendar quarter on which the specified 365-day rolling average exceeds the applicable limit.

(e) Requirements for 80₂ emission reductions from FCCDs (Part VI):

i. Failure to meet final emission limits for the FeCD exhaust gas at each refinery: \$750 for each calendar day in a calendar quarter on which the specified 7-day rolling average exceeds the applicable limit; \$2,500 for each calendar day in a calendar quarter on which the specified 365-day rolling average exceeds the applicable limit.

11. For failure to comply with any requirement of the 802 Reducing Catalyst Additives protocol, as set forth in Appendix E, including submission of the Optimization and Demonstration Reports, per unit, per day:

<u>Period of Delay or Non-Compliance</u>	<u>Penalty per day</u>
1 st through 30 th day after deadline	\$1,000
31 st through 60 th day after deadline	\$1,500
Beyond 60 th day after deadline	\$2,000 or an amount equal to 1.2 times the economic benefit of the delayed compliance, whichever is greater

- iii. For failure to comply with the plan required by Paragraph 85 for operating the FeeDs in the event of a Hydrotreater Outage, per unit, per day:

<u>Period of Delay</u>	<u>Penalty per day</u>
15 th through 30 th day after deadline	\$250
31 st through 60 th day after deadline	\$1,000
Beyond 60 th day after deadline	\$2,000 or an amount equal to 1.2 times the economic benefit of delayed compliance, whichever is greater

- (t) Requirements for CO and particulate emissions controls for FCEUs (Part VII):

- i. Failure to comply with CO emission limit: \$750 for each calendar day in a calendar quarter on which the specified I-hour average exceeds the applicable limit.
- ii. Failure to comply with particulate emission limit: \$3,000 for each calendar day in a calendar quarter on which the Refinery exceeds the specified limit.

- (g) Requirements for NSPS applicability to FceD regenerators (Part VIII):

Failure to comply with NSPS emission limits, as required by Part VIII. per day per emission limit per emission point.

<u>Period of Non-Compliance</u>	<u>Penalty per day</u>
1 st through 30 th day	\$2,500
Beyond 31 st day	\$5,000 or an amount equal to 1.2 times the economic benefit of delayed compliance, whichever is greater

- ii. Forburning Fuel Oil in a manner inconsistent with the requirements of Paragraphs 113 and 114 per unit, per day:

<u>Period of Non-Compliance</u>	<u>Penalty per day</u>
1 st through 30 th day	\$1,750
Beyond 31 st day	\$5,000 or an amount equal to 1.2 times the economic benefit of delayed compliance, whichever is greater

111. For failure to comply with the NSPS Subpart J emission limits under Paragraphs 221 or 222 per unit, per day in a calendar quarter:

<u>Period of Non-Compliance</u>	<u>Penalty per day</u>
1 st through 30 th day	\$1,000
31 st through 60 th day	\$2,000
Over 60 days	\$3,000 or an amount equal to 1.2 times the economic benefit of delayed compliance, whichever is greater

- iv. For failure to eliminate, control, and/or include and monitor all sulfur pit emissions in accordance with the requirements of Paragraph 226, per unit, per day:

<u>Period of Non-Compliance</u>	<u>Penalty per day</u>
1 st through 30 th day	\$1,000
31 st through 60 th day	\$1,750
Beyond 60 th day	\$4,000 or an amount equal to 1.2 times the economic benefit of delayed compliance whichever is greater

Dm

- v. For failure to comply with the Preventive Maintenance and Operation Plan or complete revisions required by the Denver SRP Optimization Study Report under Paragraph 229 or 223 as specified in such paragraphs, per Refinery, per day:

<u>Period of Delay or Non-Compliance</u>	<u>Penalty per day</u>
1 st through 30 th day after deadline	\$500
31 st through 60 th day	\$1,500
Over 60 days	\$2,000

- vi. Each rolling 12-hour average of sulfur dioxide emissions from any SRP in excess of the limitation at 40 C.F.R § 60.104(a)(2)(i) that is not attributable to Startup, Shutdown, or Malfunction of the SRP, or that is not attributable to Malfunction of the associated TGTU:

Number of rolling 12-hr average exceedances within calendar day	Penalty per rolling 12-hr average exceedance
1 - 12	\$350
Over 12	\$750

- vb. Operation of the SRP during Scheduled Maintenance of its associated TGTU (except that this paragraph shall not apply during periods in which Valero is engaged in the Shutdown of an SRP for, or Startup of an SRP following, Scheduled Maintenance of the SRP): \$25,000 per SRP per day per refinery.
- (h) Requirements for Benzene Waste NESHAP program enhancements (part X):
- i.) Failure to timely conduct audit or compliance review and verification under Section X.C and X.G: \$7,500 per month per review/audit.

- ii.) Failure to timely sample under Section X.K: \$250 per week, per stream or \$15,000 per quarter, per stream (whichever amount is greater, but not to exceed \$75,000 per refinery per quarter).
- iii.) Failure to timely install carbon canister under Section X.E: \$1,000 per day per canister.
- iv.) Failure to timely replace carbon canister under Section X.E: \$1,000 per day per canister
- v.) Failure to perform monitoring under Section X.L: \$500 per monitoring event.
- vi.) Failure to develop and timely implement training program under Section X.I: \$10,000 per quarter per refinery
- vii.) Failure to mark segregated stormwater drains under Section X.L: \$1,000 per week per drain
- viii.) If it is discovered by an EPA or state investigator or inspector, or their agent, that Valero failed to include all benzene waste streams in its TAB, for each waste stream that is:
 - Less than 0.03 Mg/yr - \$250 per stream;
 - Between 0.03 and 0.1 Mg/yr - \$1,000 per stream;
 - Between .01 Mg/yr and 0.5 Mg/yr - \$5,000 per stream.;
 - Greater than .5 Mg/yr- \$10,000 per stream.
- (i) Requirements for Leak Detection and Repair program enhancements (Part XI):
 - i.) Failure to have written LDAR program under Section XLB: \$3,500 per week

RS

- ii.) Failure to implement the training program under Section XI.C: \$10,000 per month, per program.
- iii.) Failure to timely conduct internal or external audit under Section XI.D: \$5,000 per month per audit.
- iv.) Failure to timely implement internal leak definition under Section XI.G: \$10,000 per month per process unit.
- v.) Failure to develop and timely implement initial attempt at repair program under Section XII: \$10,000 per month.
- vi.) Failure to implement and begin more frequent monitoring program under Section XU: \$10,000 per month per process unit.
- vii.) Failure to timely monitor under Section XI.J: \$10,000 per week per process unit.
- viii.) Failure to have dataloggers and electronic storage under Section XI.K: \$5,000 per month per refinery.
- ix.) Failure to timely establish LDAR accountability under Section XI.M: \$3,750 per week per refinery.
- x.) Failure to establish new equipment standards under Section XLN: \$1,000 per month.
- xi.) Failure to conduct calibration drift assessment or to remonitor components (if and as required) under Section XI.O: \$100 per missed event per day per refinery.
- xii.) Failure to attempt the drill and tap method under Section XI.Q: \$5,000 per component.
- xiii.) For failure to comply with the requirement for chronic leakers set forth in Paragraph 212 : \$5,000 per valve.

xiv.) If it is discovered by an EPA or state investigator or inspector, or their agent, that Valero failed to include all required components in its LDAR program: \$87.50 per component.

- (l) For failure to implement the CFIT or to submit status reports required in Paragraph 285: \$500 per incident or required report.
- (m.) Requirement to Escrow Stipulated Penalties: Failure to escrow stipulated penalties, as required by Paragraph 322 of this Part: \$1,250 per day, and interest on the amount overdue at the rate specified in 28 U.S.C. § 1961(a).

RJA

(n.) As to any failure to complete an obligation pursuant to this Consent Decree that does not otherwise have a specified stipulated penalty, the United States, relevant Plaintiff-Intervener and Valero or Tesoro, as applicable, may reach agreement on a stipulated penalty amount and such agreed stipulated penalty may be assessed and paid pursuant to this Part XX.

321. Valero or Tesoro, as applicable, shall pay such stipulated penalties upon written demand by the United States or the appropriate Plaintiff-Intervener no later than sixty (60) days after Defendant receives such demand. Demand from either the United States or the appropriate Plaintiff-Intervener shall be deemed a demand from both; but the United States and the appropriate Plaintiff-Intervener shall consult with each other prior to making a demand. Stipulated penalties owed by Valero or Tesoro shall be paid 50% to the United States and 50% to the appropriate Plaintiff-Intervener. Stipulated penalties shall be paid in the manner set forth in Part XVII unless the payment to the United States is less than \$10,000, in which case such payment shall be certified or company check, payable to the appropriate United States Attorneys Office. A demand for the payment of stipulated penalties will identify the particular violation(s) to which it relates, the amounts demanded for each violation (as can be best estimated), the calculation method underlying the demand and the grounds upon which the demand is based. After consultation with each other, the United States and the appropriate Plaintiff-Intervener may, in their unreviewable discretion, waive payment of any portion of stipulated penalties that may accrue under this Consent Decree. Where a single event triggers more than one stipulated penalty provision in this Consent Decree, only one such provision will apply.

322. Should Valero or Tesoro, as applicable, dispute its obligation to pay part or all of a stipulated penalty, it may avoid the imposition of the stipulated penalty for failure to pay a

penalty due to the United States or the appropriate Plaintiff-Intervener, by placing the disputed amount demanded by the United States or the Plaintiff-Intervener in a commercial escrow account pending resolution of the matter and by invoking the Dispute Resolution provisions of Part XXIII within the time provided in Paragraph 321 for payment of stipulated penalties. If the dispute is thereafter resolved in Valero's or Tesoro's favor, as applicable, the escrowed amount plus accrued interest shall be returned to Valero or Tesoro, as applicable, otherwise the United States or the appropriate Plaintiff-Intervener shall be entitled to the escrowed amount that was determined to be due by the Court plus the interest that has accrued on such amount, with the balance, if any, returned to Valero or Tesoro, as applicable.

323. Nothing in this Consent Decree shall prevent the United States or the appropriate Plaintiff-Intervener from pursuing a contempt action against Valero or Tesoro in lieu of demanding stipulated penalties hereunder and requesting that the Court order specific performances of the terms of this Consent Decree. Nothing in this Consent Decree authorizes the appropriate Plaintiff-Intervener to take action or make any determinations under this Consent Decree regarding Valero or Tesoro refineries that are outside that Plaintiff-Intervener's state or that are not subject to this Consent Decree.

324. The United States and the appropriate Plaintiff-Intervener reserve the right to pursue any other non-monetary remedies to which they are legally entitled, including but not limited to injunctive relief for violations of the Consent Decree. Where a violation of this Consent Decree is also a violation of the Clean Air Act, its regulations or federally enforceable state law, regulation or permit, the United States (or the appropriate Plaintiff-Intervener) will not seek civil penalties where it already has demanded and secured stipulated penalties for the same act or omission, nor will the United States (or the appropriate Plaintiff-Intervener) demand

stipulated penalties for a violation of the Consent Decree if it has commenced litigation under the Clean Air Act for the same acts or omissions. Where a violation of this Consent Decree is also a violation of state law, regulation or a permit, the Plaintiff-Interveners will not seek civil or administrative penalties where they have already demanded and secured stipulated penalties for the same acts or omissions, nor will the Plaintiff-Interveners demand stipulated penalties for a violation of the Consent Decree if it has commenced litigation under the Clean Air Act for the same acts or omissions.

XXI. RIGHT OF ENTRY

325. Any authorized representative of the EPA or an appropriate state agency, including their independent contractors, upon presentation of credentials, shall have a right of entry upon the premises of Valero's Refineries and Tesoro's Golden Eagle Refinery at any reasonable time for the purpose of monitoring compliance with the provisions of this Consent Decree, including inspecting plant equipment, and inspecting and copying all records maintained as required by this Consent Decree. Nothing in this Consent Decree shall limit the authority of EPA to conduct tests and inspections under Section 114 of the Clean Air-Act, 42 U.S.C. § 7414, or any other statutory or regulatory provision.

XXII. FORCE MAJEURE

326. If any event occurs which causes or may cause a delay or impediment to performance in complying with any provision of this Consent Decree (e.g. would require operation in an unsafe manner), and which Valero or Tesoro believes qualifies as an event of force majeure, Valero or Tesoro, as applicable, shall notify the United States and Plaintiff-Intervener in writing as soon as practicable, but in any event within forty-five (45) business days of when Valero or Tesoro, as applicable, first knew of the event or should have known of the

event by the exercise of due diligence. In this notice Valero or Tesoro, as applicable, shall specifically reference this paragraph of this Consent Decree and describe the anticipated length of time the delay may persist, the cause or causes of the delay, and the measures taken or to be taken by Valero and Tesoro, as applicable, to prevent or minimize the delay and the schedule by which those measures will be implemented. Valero and Tesoro shall adopt all reasonable measures to avoid or minimize such delays.

327. Failure by Valero or Tesoro, as applicable, to substantially comply with the notice requirements of Paragraph 326, as specified above, shall render this Part voidable by the United States, after an opportunity for consultations with the Plaintiff-Intervener, as to the specific event for which Valero or Tesoro, as applicable, has failed to comply with such notice requirement. If so voided, it shall be of no effect as to the particular event involved.

328. The United States, after an opportunity for consultation with the Plaintiff-Intervener, shall notify Valero or Tesoro, as applicable, in writing regarding their claim of a delay or impediment to performance within forty-five (45) business days of receipt of the Force Majeure notice provided under Paragraph 326.

329. If the United States, after an opportunity for consultation with the Plaintiff-Intervener, agrees that the delay or impediment to performance has been or will be caused by circumstances beyond the control of Valero or Tesoro, as applicable, including any entity controlled or contracted by it, and that it could not have prevented the delay by the exercise of due diligence, the parties shall stipulate to an extension of the required deadline(s) for all requirement(s) affected by the delay by a period equivalent to the delay actually caused by such circumstances, or such other period as may be appropriate in light of the circumstances. Such stipulation may be filed as a modification to this Consent Decree by agreement of the parties

pursuant to the modification procedures established in this Consent Decree. Valero or Tesoro, as applicable, shall not be liable for stipulated penalties for the period of any such delay.

330. If the United States and appropriate Plaintiff-Intervener do not accept Valero's or Tesoro's claim of a delay or impediment to performance or Event of Force Majeure pursuant to this Consent Decree, then Valero or Tesoro, as applicable, must submit the matter to this Court for resolution to avoid payment of stipulated penalties, by filing a petition for determination with this Court. In the event that the United States and Plaintiff-Intervener do not agree, the position of the United States on the Force Majeure claim shall become the final Plaintiffs' position. Once Valero or Tesoro has submitted this matter to this Court, the United States and appropriate Plaintiff-Intervener shall have twenty (20) business days to file a response to the petition. If Valero or Tesoro submits the matter to this Court for resolution and the Court determines that the delay or impediment to performance has been or will be caused by circumstances beyond the control of Valero or Tesoro, as applicable, including any entity controlled or contracted by it, and that it could not have prevented the delay by the exercise of due diligence, Valero or Tesoro, as applicable, shall be excused as to that event(s) and delay (including stipulated penalties) for all requirements affected by the delay for a period of time equivalent to the delay caused by such circumstances or such other period as may be determined by the Court.

331. Valero and Tesoro shall bear the burden of proving that any delay of any requirement(s) of this Consent Decree was caused by or will be caused by circumstances beyond its control, including any entity controlled or contracted by it, and that it could not have prevented the delay by the exercise of due diligence. Valero and Tesoro shall also bear the burden of proving the duration and extent of any delay(s) attributable to such circumstances. An extension of one compliance date based on a particular event may, but does not necessarily,

result in an extension of a subsequent compliance date or dates. Unanticipated or increased costs or expenses associated with the performance of obligations under this Consent Decree shall not constitute circumstances beyond the control of either Valero or Tesoro.

332. Notwithstanding any other provision of this Consent Decree, this Court shall not draw any inferences nor establish any presumptions adverse to any party as a result of Valero or Tesoro delivering a notice of Force Majeure or the parties' inability to reach agreement.

333. As part of the resolution of any matter submitted to this Court under this Part, the parties by agreement, or this Court by order, may in appropriate circumstances extend or modify the schedule for completion of work under this Consent Decree to account for the delay in the work that occurred as a result of any delay or impediment to performance agreed to by the United States and the appropriate Plaintiff-Intervener or approved by this Court. Valero or Tesoro, as applicable, shall be liable for stipulated penalties for its failure thereafter to complete the work in accordance with the extended or modified schedule, except to the extent that such schedule is further modified, extended or otherwise affected by a subsequent force majeure event under this Part XXII.

XXIII. DISPUTE RESOLUTION

334. The dispute resolution procedure provided by this Part shall be available to resolve all disputes arising under this Consent Decree, except as otherwise provided in Part XXII regarding Force Majeure, provided that the party making such application has made a good faith attempt to resolve the matter with the other party.

335. The dispute resolution procedure required herein shall be invoked upon the giving of written notice by one of the parties to this Consent Decree to another advising of a dispute pursuant to this Part. The notice shall describe the nature of the dispute, and shall state the

noticing party's position with regard to such dispute. The party or parties receiving such a notice shall acknowledge receipt of the notice and the parties shall expeditiously schedule a meeting to discuss the dispute informally not later than fourteen (14) days from the receipt of such notice.

336. Disputes submitted to dispute resolution shall, in the first instance, be the subject of informal negotiations between the parties. Such period of informal negotiations shall not extend beyond thirty (30) calendar days from the date of the first meeting between representatives of the United States, the appropriate Plaintiff-Intervener and Valero or Tesoro, as applicable, unless the parties' representatives agree to shorten or extend this period.

337. In the event that the parties are unable to reach agreement during such informal negotiation period, the United States and the appropriate Plaintiff-Intervener shall provide Valero or Tesoro, as applicable, with a written summary of their collective position regarding the dispute. The position advanced by the United States and Plaintiff-Intervener shall be considered binding unless, within forty-five (45) calendar days of Valero's or Tesoro's receipt of the written summary of the United States and Plaintiff-Intervener's position, Valero or Tesoro, as applicable, files with this Court a petition which describes the nature of the dispute. The United States shall respond to the petition within forty-five (45) calendar days of filing.

338. In the event the United States and the Plaintiff-Intervener make differing determination or take differing actions that affect Valero or Tesoro's rights or obligations under this Consent Decree, then as between the United States and the Plaintiff-Intervener the determination or action of the United States shall control.

339. Where the nature of the dispute is such that a more timely resolution of the issue is required, the time periods set out in this Part may be shortened upon motion of one of the parties to the dispute.

340. Notwithstanding any other provision of this Consent Decree, in dispute resolution, this Court shall neither draw any inferences nor establish any presumptions adverse to either party as a result of invocation of this Part or the parties' inability to reach agreement.

341. As part of the resolution of any dispute submitted to dispute resolution, the parties by agreement, or this Court by order, in appropriate circumstances, may extend or modify the schedule for completion of work under this Consent Decree to account for the delay in the work that occurred as a result of dispute resolution. Valero or Tesoro, as applicable, shall be liable for stipulated penalties for its failure thereafter to complete the work in accordance with the extended or modified schedule, subject to the Force Majeure provisions of Part XXII.

XXIV. EFFECT OF SETTLEMENT

342. This Consent Decree is not a permit; except as otherwise provided herein, compliance with its terms does not ensure compliance with any applicable federal, state or local laws or regulations governing air quality permitting requirements. Except as otherwise expressly provided herein, nothing in this Consent Decree shall be construed to be a ruling on, or determination of, any issue related to any Federal, state or local permit.

343. Definitions. For purposes of this Part XXIV (Effect of Settlement), the following definitions apply:

a. "Applicable NSR/PSD Requirements" shall mean: PSD requirements at Part C of Subchapter I of the Act, 42 U.S.C. § 7475, and the regulations promulgated thereunder at 40 C.F.R. §§ 52.21 and 51.166; the portions of the applicable SIPs and related rules adopted as required by 40 C.F.R. §§ 51.165 and 51.166; "Plan Requirements for Non-Attainment Areas" at Part D of Subchapter I of the Act, 42 U.S.C. §§ 7502-7503, and the regulations promulgated thereunder at 40 C.F.R. §§ 51.165 (a) and (b), 40 C.F.R. Part 51, Appendix S, and 40 C.F.R. §

52.24; Title V regulations or permit provisions that implement, adopt or incorporate the specific regulatory requirements identified above; and state or local regulations or permits that implement, adopt, or incorporate the specific federal regulatory requirements identified above.

b. "Applicable NSPS Subparts A and J Requirements" shall mean the standards, monitoring, testing, reporting and recordkeeping requirements, found at 40 C.F.R. §§ 60.100 through 60.109 (Subpart J), relating to a particular pollutant and a particular affected facility, and the corollary general requirements found at 40 C.F.R. §§ 60.1 through 60.19 (Subpart A) that are applicable to any affected facility covered by Subpart J; any Title V regulations that implement, adopt or incorporate the specific regulatory requirements identified above; any applicable, federally-enforceable state or local regulations that implement, adopt, or incorporate the specific federal regulatory requirements identified above, and any Title V permit provisions that implement, adopt or incorporate the specific regulatory requirements identified above; and any applicable state or local regulations, or permits enforceable by Plaintiff-Interveners that implement, adopt, or incorporate the specific federal regulatory requirements identified above.

c. "Post-Lodging Compliance Dates" shall mean any dates after the Date of Lodging provided in the relevant sections of this Consent Decree. Post-Lodging Compliance Dates include dates certain (e.g., "December 31, 2004"), dates after Lodging represented in terms of "months after Lodging" (e.g., "Twelve Months after the Date of Lodging"), and dates after Lodging represented by actions taken (e.g., "Date of Certification"). The Post-Lodging Compliance Dates represent the dates by which work is required to be completed or an emission limit is required to be met under the applicable provisions of this Consent Decree.

344. Resolution of Liability Regarding the Applicable NSRIPSD Requirements.
With respect to emissions of the following pollutants from the following units, entry of this

Consent Decree shall resolve all civil liability to the United States and the Plaintiff-Interveners for violations of the Applicable NSR/PSD Requirements resulting from pre-Lodging construction or modification:

- A. Emissions of SO₂ from the FCCUs at the Valero Refineries and the Tesoro Golden Eagle Refinery and from the Corpus Christi West HOC and the Benicia Coker.
- B. Emissions of NO_x from each Covered FCCU, including the Corpus Christi West HOC, and from the Golden Eagle FCCU.
- C. Emission of NO_x and SO₂ from all heaters and boilers at the Valero Refineries and the Golden Eagle Refinery.

345. Resolution of Liability for PM Emissions Under the Applicable NSR/PSD Requirements. With respect to emissions of PM from the FCCUs at the Valero Refineries and the Golden Eagle Refinery and from the Corpus Christi West HOC when Valero or Tesoro, as applicable, accepts an emission limit of 0.5 pound PM per 1000 pounds of coke burned (front half only according to Method 5B or SF, as appropriate) on a 3-hour average basis and demonstrates compliance by conducting a 3-hour performance test representative of normal operating conditions for PM emissions at a particular Refinery, then all civil liability to the United States and the Plaintiff-Interveners shall be resolved for violations of the Applicable NSR/PSD Requirements relating to PM emissions at the relevant Refinery resulting from pre-Lodging construction or modification of the FCCU at that Refinery or of the Corpus Christi West HOC.

346. Resolution of Liability for CO Emissions Under the Applicable NSR/PSD Requirements. With respect to emissions of CO from the FCCUs at the Valero Refineries and

the Golden Eagle Refinery and from the Corpus Christi West HOC, if and when Valero or Tesoro, as applicable, accepts an emission limit of 100 ppmvd of CO at 0% O₂ on a 365-day rolling average basis and demonstrates compliance using CEMS at the relevant Refinery, then all civil liability to the United States and the Plaintiff-Interveners shall be resolved for violations of the Applicable NSR/PSD Requirements relating to CO emissions at the relevant Refinery resulting from pre-Lodging construction or modification of the FCCU for that Refinery, the Benicia coker or the Corpus Christi West HOC.

347. **Resolution of Liability Regarding the Applicable NSR/PSD Requirements for the McKee Acid Plant.** With respect to emissions from the McKee Acid Plant, entry of this Consent Decree shall resolve all civil liability to the United States and the Plaintiff-Interveners for violations of the Applicable NSR/PSD Requirements resulting from pre-Lodging construction or modification and any pre-Lodging violations of the Applicable NSPS Subparts A and H Requirements from the date that the claims of the United States and the Plaintiff-Interveners accrued up to the relevant Post-Lodging Compliance Date.

348. **Exclusions from Release Coverage Regarding Applicable NSR/PSD Requirements:** Notwithstanding the resolution of liability in Paragraphs 345-347, nothing in this Consent Decree precludes the United States and/or the Plaintiff-Interveners from seeking from Valero or Tesoro, as appropriate, injunctive relief, penalties, or other appropriate relief for violations by Valero or Tesoro, as appropriate, of the Applicable NSR/PSD Requirements resulting from: (1) construction or modification that commenced prior to the Date of Lodging of the Consent Decree, if the resulting violations relate to pollutants or units not covered by the Consent Decree; or (2) any construction or modification that commences after the Date of Lodging of the Consent Decree.

349. Exclusions from Resolution of Liability Under Applicable PSDINSR Requirements. Increases in emissions from units covered by this Consent Decree, where the increases result from the Post-Lodging construction or modification as defined by 40 C.F.R 52.21 of any units within the Valero or Tesoro Refineries, as appropriate, are beyond the scope of the release in Paragraphs 345-347.

350. Resolution of Liability Regarding Matters on Appendix O and Appendix R. With respect to the enforcement matters identified in Appendix Q and Appendix R, entry of this Consent Decree shall resolve all civil liability to the United States and the Plaintiff-Interveners for the violations identified, alleged or resolved in Appendix Q and Appendix R, in the manner and to the extent set forth therein, from the date that the claims of the United States and the Plaintiff-Interveners accrued up to the relevant Post-Lodging Compliance Dates.

351. Resolution of Liability Regarding Applicable NSPS Subparts A and J Requirements. With respect to Opacity and emissions of SO_x, PM, and CO, as applicable, from the all heaters and boilers, SRPs, fuel gas combustion devices, the ColpUS Christi West HOC and the FCCDs at the Valero Refineries and the Golden Eagle Refinery, entry of this Consent Decree shall resolve all civil liability to the United States and the Plaintiff-Interveners for pre-Lodging violations of the Applicable NSPS Subparts A and J Requirements from the date that the claims of the United States and the Plaintiff-Interveners accrued up to the relevant Post-Lodging Compliance Dates.

352. Prior NSPS Applicability Determinations. Nothing in this Consent Decree shall affect the status of any FCCD, heater or boiler, fuel gas combustion device, or sulfur recovery plant currently subject to NSPS as previously determined by any federal, state, or local authority or any applicable permit.

353. Resolution of Liability Regarding Benzene Waste NESHAP Requirements.

Entry of this Consent Decree shall resolve all civil liability to the United States and the Plaintiff-Intervenors for violations of the statutory and regulatory requirements set forth below in subparagraphs i. through iii. (the "BWON Requirements") that (1) commenced and ceased prior to the Date of Entry of the Consent Decree; and (2) commenced prior to the Date of Entry of the Consent Decree and/or continued past the Date of Entry, provided that the events giving rise to such violations are identified by Valero or Tesoro, as appropriate, in its BWON Compliance Review and Verification Report(s) submitted pursuant to Paragraph 128 and corrected by Valero or Tesoro, as appropriate, as required under section X.D.:

- i. Benzene Waste NESHAP. The National Emission Standard for Benzene Waste Operations, 40 C.F.R. Part 61, Subpart FF, promulgated pursuant to Section 112(e) of the Act, 42 U.S.C. § 7412(e), including any federal regulation or permit that adopts or incorporates the requirements of Subpart FF by express reference, but only to the extent of such adoption or incorporation; and
- ii. Any applicable, federally-enforceable state or local regulations or permits that implement, adopt, or incorporate the specific federal regulatory requirements identified in Paragraph 353.i.
- iii. Any applicable state or local regulations or permits enforceable by the Plaintiff-Intervenors that implement, adopt, or incorporate the specific federal regulatory requirements identified in Paragraph 353.i.

354. Resolution of Liability Regarding LDAR Requirements. Entry of this Consent Decree shall resolve all civil liability to the United States and the Plaintiff-Intervenors for violations of the statutory and regulatory requirements set forth below in subparagraphs a.

through c. that (1) commenced and ceased prior to the Date of Entry of the Consent Decree; and (2) commenced prior to the Date of Entry of the Consent Decree and continued past the Date of Entry, provided that the events giving rise to such violations are identified by Valero or Tesoro, as appropriate, in its Initial Audit Report(s) submitted pursuant to Paragraph 188 and corrected by Valero or Tesoro, as appropriate, as required under Paragraph 192:

a. LDAR Requirements. For all equipment in light liquid service and gas and/or vapor service, the LDAR requirements of Plaintiff-Interveners under state implementation plans adopted pursuant to the Clean Air Act or promulgated by EPA pursuant to Sections 111 and 112 of the Clean Air Act, and codified at 40 C.F.R. Part Subparts VV and GGG; 40 C.F.R. Part 61, Subparts J and V; and 40 C.F.R. Part 63, Subparts F, H, and CC;

b. Any applicable, federally-enforceable state or local regulations or permits that implement, adopt, or incorporate the specific regulatory requirements identified in Paragraph 354.a.

c. Any applicable state or local regulations or permits enforceable by the Plaintiff-Interveners that implement, adopt, or incorporate the specific regulatory requirements identified in Paragraph 354.a.

354A. Resolution of Other Enforcement Matters. In addition to the foregoing matters, this Consent Decree resolves, settles, and finally satisfies claims against Valero or Tesoro, as applicable, asserted by or available to the United States and/or Plaintiff-Interveners to the extent specifically listed in Appendix Q or R hereto. Entry of this Consent Decree shall resolve all civil and administrative liability of Valero or Tesoro, as applicable, to the United States and the Plaintiff-Interveners for the matters set forth in Appendix Q or R in the manner and to the extent set forth therein.

355. Reservation of Rights Regarding Benzene NESBAP and LDAR Requirements.

Notwithstanding the resolution of liability in Paragraphs 353 and 354, nothing in this Consent Decree precludes the United States and/or the Plaintiff-Interveners from seeking from Valero or Tesoro, as appropriate, injunctive and/or other equitable relief for civil penalties for violations by Valero or Tesoro, as appropriate, of Benzene Waste NESHAP and/or LDAR requirements that (1) commenced prior to the Date of Entry of this Consent Decree and continued after the Date of Entry if Valero or Tesoro, as appropriate, fails to identify **and** address such violations as required by Paragraphs 128, 188, 192 and/or section X.D of this Consent Decree; or (2) commenced after the Date of Entry of the Consent Decree.

356. Audit Policy. Nothing in this Consent Decree is intended to limit or disqualify Valero or Tesoro, as appropriate, on the grounds that information was not discovered and supplied voluntarily, from seeking to apply EPA's Audit Policy or any state or local audit policy to any violations or non-compliance that Valero or Tesoro, as appropriate, discovers during the course of any investigation, audit, or enhanced monitoring that Valero or Tesoro, as appropriate, is required to undertake pursuant to this Consent Decree.

357. Claim/Issue Preclusion. In any subsequent administrative or judicial proceeding initiated by the United States or the Plaintiff-Interveners for injunctive relief, penalties, or other appropriate relief relating to Valero or Tesoro, as appropriate, for violations of the PSD/INSR, NSPS, NESHAP, and/or LDAR requirements, not identified in Part XXIV (Effect of Settlement) of the Consent Decree and/or the Complaint:

a. Valero or Tesoro, as appropriate, shall not assert, and may not maintain, any defense or claim based upon the principles of waiver, res judicata, collateral estoppel, issue preclusion, or claim-splitting as a result of this Consent Decree. Nor may Valero or Tesoro, as

appropriate, assert or maintain any other defenses based upon any contention that the claims raised by the United States or the Plaintiff-Interveners in the subsequent proceeding were or should have been brought in the instant case. Nothing in the preceding sentences is intended to affect the ability of Valero or Tesoro, as appropriate, to assert that the claims are deemed resolved by virtue of Part XXV of the Consent Decree.

b. Except in enforcing Paragraph 357.a. the United States and the Plaintiff-Interveners may not assert or maintain that this Consent Decree constitutes a waiver or determination of, or otherwise obviates, any claim or defense whatsoever of Valero or Tesoro, or that this Consent Decree constitutes acceptance by Valero or Tesoro of any interpretation or guidance issued by EPA related to the matters addressed in this Consent Decree.

358. Imminent and Substantial Endangerment. Nothing in this Consent Decree shall be construed to limit the authority of the United States and the Plaintiff-Interveners to undertake any action against any person, including Valero or Tesoro, as appropriate, to abate or correct conditions which may present an imminent and substantial endangerment to the public health, welfare, or the environment, or limit the authority of a Plaintiff-Intervener to take action under similar circumstances under state statute or common law that may be necessary to protect the public health, safety, welfare and the environment.

XXV. TERMINATION

359. This Consent Decree shall be subject to termination upon motion by the United States or Valero or Tesoro, as applicable, under the conditions identified in Paragraph 363 below. Prior to seeking termination, Valero or Tesoro, as applicable, must have completed and satisfied all of the following requirements of this Consent Decree:

a. Installation of control technology systems as specified in this Consent Decree;

- b. Compliance with all provision contained in this Consent Decree, which compliance may be established for specific parts of the Consent Decree in accordance with Paragraph 360 below.
- c. Payment of all penalties and other monetary obligations due under the terms of the Consent Decree; no penalties or other monetary obligations due hereunder can be outstanding or owed to the United States or the Plaintiff-Interveners;
- d. Completion of the Supplemental Environmental Projects as set forth in Part XIX; and
- e. Application for and receipt of permits incorporating the emission limits and standards required by Part XIV [Permits].

360. **Certification of Completion.** Prior to moving for termination, Valero or Tesoro, as applicable, may certify completion for one or more Refineries subject to this Consent Decree of one or more of the following parts of the Consent Decree, provided that all of the related requirements for that Refinery have been satisfied:

- i. Part V - NO_x Emission Reductions from Fluid Catalytic Cracking Unit (including operation of the unit for one year after completion in compliance with the emission limit set pursuant to the Consent Decree);
- ii, Parts VI, VII and VIII - SO₂, CO, particulate and opacity Emission Reductions from Fluid Catalytic Cracking Unit (including operation of the unit for one year after completion in compliance with the emission limits set pursuant to the Consent Decree);

- iii Parts IV and IX – Heaters and Boilers (including operation of the relevant units for one year after completion in compliance with the emission limit set pursuant to the Consent Decree);
- iv. Parts X and XI- BWON and LDAR;
- v. Part XII – SRPs and Flares
- vi. Part XIX – Beneficial and Supplemental Environmental Projects

361. If Valero or Tesoro, as applicable, elects to certify completion of any of the parts of the Consent Decree identified in Paragraph 360 for any Refinery subject to this Consent Decree, then Valero or Tesoro, as applicable, may submit a written report to EPA and the appropriate Plaintiff-Intervener describing the activities undertaken and certifying that the applicable Parts have been completed in full satisfaction of the requirements of this Consent Decree, and that Valero or Tesoro, as applicable, is in substantial and material compliance with all of the other requirements of the Consent Decree. The report shall contain the following statement, signed by a responsible corporate official of Valero or Tesoro, as applicable:

"To the best of my knowledge, after thorough investigation, I certify that the information contained in or accompanying this submission is true, accurate and complete. I am aware that there are significant penalties for submitting false information, including the possibility of fine and imprisonment for knowing violations."

362. Upon receipt of Valero's or Tesoro's certification, as applicable, EPA, after reasonable opportunity for review and comment by the Plaintiff-Interveners, shall notify Valero or Tesoro, as applicable, whether the requirements set forth in the applicable Part(s) have been

completed in accordance with this Consent Decree. The parties recognize that ongoing obligations under such Part(s) remain and necessarily continue (e.g., reporting, record keeping, training, auditing requirements), and that Valero's or Tesoro's certification, as applicable, is that it is in current compliance with all such obligations.

a. If EPA concludes that the requirements of such Part(s) have not been fully complied with in accordance with this Consent Decree, EPA shall notify Valero or Tesoro, as applicable, as to the activities that must be undertaken to complete the applicable Parts of the Consent Decree. Valero or Tesoro, as applicable, shall perform all activities described in the notice, subject to its right to invoke the dispute resolution procedures set forth in Part XXIII (Dispute Resolution).

b. If EPA concludes that the requirements of the applicable paragraphs have been completed in accordance with this Consent Decree, EPA will so certify in writing to Valero or Tesoro, as applicable. This certification shall constitute the certification of completion of the applicable Parts for purposes of this Consent Decree.

Nothing in this Paragraph 362 shall preclude the United States or the Plaintiff-Interveners from seeking stipulated penalties for a violation of any of the requirements of the Consent Decree regardless of whether a Certification of Completion has been issued under this paragraph. In addition, nothing in this Paragraph 362 shall permit Valero or Tesoro, as applicable, to fail to implement any ongoing obligations under the Consent decree regardless of whether a Certification of Completion has been issued with respect to this paragraph of the Consent Decree.

363. At such time as Valero or Tesoro, as applicable, believes that it has satisfied the requirements for termination set forth in Paragraph 359, it shall certify such compliance and completion to the United States and the Plaintiff-Interveners in writing. Unless either the United States or any Plaintiff-Intervener objects in writing with specific reasons within 120 days of receipt of Valero's or Tesoro's certification under this paragraph, Valero shall then move and the Court may order that this Consent Decree be terminated. If either the United States or any Plaintiff-Intervener objects to the certification by Valero or Tesoro, as applicable, then the matter shall be submitted to the Court for resolution under Part XXIII (Dispute Resolution) of this Consent Decree.

364. The Effect of Settlement provisions set forth in Part XXIV shall survive termination of this Consent Decree.

XXVI. GENERAL PROVISIONS

365. Effect of Refinery or Source Shutdown. Notwithstanding any provision of this Consent Decree, the permanent shutdown of any source or refinery subject to any requirement of this Consent Decree shall satisfy any provision in this Consent Decree applicable to such source or refinery, and Valero shall not be obligated hereunder to continue operation of such source or refinery in order to institute or satisfy any requirement otherwise applicable to such source or refinery pursuant to the terms of the Consent Decree. The foregoing does not relieve Valero's or Tesoro's ongoing obligation to implement Part XIX [SEPs].

366. Other Laws. Except as specifically provided by this Consent Decree, nothing in this Consent Decree shall relieve Valero or Tesoro of its obligation to comply with all applicable federal, state and local laws and regulations, including, but not limited to, more stringent standards. In addition, nothing in this Consent Decree shall be construed to prohibit or prevent

the United States or Plaintiff-Interveners from developing, implementing, and enforcing more stringent standards subsequent to the Date of Lodging of this Consent Decree through rulemaking, the permit process, or as otherwise authorized or required under federal, state, regional, or local laws and regulations. In addition, except as otherwise expressly provided in this Consent Decree, nothing in this Consent Decree is intended to eliminate, limit or otherwise restrict any compliance options, exceptions, exclusions, waivers, variances, or other right otherwise provided or available to Valero or Tesoro under any applicable statute, regulation, ordinance, regulatory or statutory determination, or permitting process. Subject to Part XXIV [Effect of settlement] and except as provided under Part XX [Stipulated Penalties], nothing contained in this Consent Decree shall be construed to prevent, alter or limit the United States' and Plaintiff-Interveners' rights to seek or obtain other remedies or sanctions against Valero or Tesoro, as applicable, available under other federal, state or local statutes or regulations, in the event that Valero or Tesoro, respectively, violates this Consent Decree or of the statutes and regulations applicable to violations of this Consent Decree. This shall include the United States' and Plaintiff-Interveners' right to invoke the authority of the Court to order Valero's or Tesoro's, as applicable, compliance with this Consent Decree in a subsequent contempt action.

367. Changes to Law. In the event that during the life of this Consent Decree there is change in the statutes or regulations that provide the underlying basis for the Consent Decree such that Valero or Tesoro, as applicable, would not otherwise be required to perform any of the obligations herein or would have the option to undertake or demonstrate compliance in an alternative or different manner. Valero or Tesoro, as applicable, may petition the Court for relief from any such requirements, in accordance with Rule 60 of the Federal Rules of Civil Procedures ("F.R.Civ.P."). However, if Valero applies to the Court for relief under this Paragraph, the

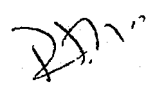
Handwritten signature or initials in black ink, appearing to be 'D.M.' with a flourish.

373. Public Documents. All information and documents submitted by Valero or Tesoro to the United States and Plaintiff-Interveners pursuant to this Consent Decree shall be subject to public inspection, unless (a) subject to legal privileges or protection or (b) identified and supported as business confidential by Valero or Tesoro, as applicable, in accordance with 40 C.F.R. Part 2, or any equivalent state statutes and regulations.

374. Public Comments. The parties agree and acknowledge that final approval by the United States and the appropriate Plaintiff-Intervener and entry of this Consent Decree is subject to the requirements of 28 C.F.R. § 50.7, which provides for notice of the lodging of this Consent Decree in the Federal Register, an opportunity for public comment, and consideration of any comments. The parties acknowledge and agree that final approval by the State of Louisiana and entry of this Consent Decree is subject to the requirements of La. R.S. 30:2050.7, which provides for public notice of this Consent Decree in newspapers of general circulation and the official journals of the Saint Landry Parish in which the Krotz Springs Refinery is located, and the Saint Charles Parish in which the St. Charles Refinery is located, and opportunity for public comment, consideration of any comments, and concurrence by the State Attorney General. The parties acknowledge and agree that final approval by the State of Texas and entry of this Consent Decree is subject to the requirements of the Texas Water Code 7.110 which will require publication for the refineries in Texas, and opportunity for public comment, consideration of any comments, and concurrence by the State Attorney General.

375. Reserved.

376. Notice. Unless otherwise provided herein, notifications hereunder to or communications with the United States, the appropriate Plaintiff-Intervener, Valero or Tesoro shall be deemed submitted on the date they are postmarked and sent either by overnight receipt

mail service or by certified or registered mail, return receipt requested. When Valero or Tesoro is required to submit notices or communicate in writing under this Consent Decree to EPA relating to one of Valero's Refineries or the Golden Eagle Refinery, Valero or Tesoro, as applicable, shall also submit a copy of that notice or other writing to the applicable Plaintiff-Intervener for the refinery located in that state. Except as otherwise provided herein, when written notification or communication is required by this Consent Decree, it shall be addressed as follows:

As to the United States:

Chief, Environmental Enforcement Section
Environment and Natural Resources Division
U.S. Department of Justice
P.O. Box 7611, Ben Franklin Station
Washington, DC 20044-7611

United States Attorney
Western District of Texas
c/o U.S. Marshal Service
U.S. Courthouse
655 E. Durango
San Antonio, TX 78206

As to the U.S. Environmental Protection Agency:

Director
Air Enforcement Division (2242A)
Office of Enforcement and Compliance Assurance
U.S. Environmental Protection Agency
1200 Pennsylvania Avenue, N.W.
Washington, D.C. 20004

With copies to the EPA Regional office where the relevant refinery is located:

EPA Region 2:

Director
Division of Enforcement and Compliance Assistance

U.S. Environmental Protection Agency, Region 2
290 Broadway - 21st Floor
New York, NY 10007-1866

EPA Region 6:

Chief
Air, Toxics, and Inspection Coordination Branch (6EN-A)
Compliance Assurance and Enforcement Division
U.S. Environmental Protection Agency, Region 6
1445 Ross Avenue
Dallas, Texas 75202

EPA Region 8

U.S. Environmental Protection Agency, Region 8
999-18th St. Suite 300
Denver, CO 80202-2466

EPA Region 9:

Director, Air Division (AIR-I)
Attn: Chief, Air Enforcement Office
U.S. Environmental Protection Agency, Region 9
75 Hawthorne Street
San Francisco, CA 94105

As to Plaintiff-Intervener, State of Colorado

Robert Jorgenson
Supervisor, Field Services Section
APCD-SS-B 1
Air Pollution Control Division
Colorado Department of Public Health & Environment
4300 Cherry Creek Drive South
Denver, Colorado 80246-1530

As to Plaintiff-Intervener, the State of Louisiana, through the Department of Environmental Quality:

Administrator
Enforcement Division
Office of Environmental Compliance
P.O. Box 4312
Baton Rouge, Louisiana 70821-4312

As to Co-Plaintiff the State of New Jersey:

Administrator, Air Compliance & Enforcement
New Jersey Department of Environmental Protection
Post Office Box 422
401 East State Street
Trenton, New Jersey 08625-0422

and

Manager, Central Air Compliance & Enforcement Office
New Jersey Department of Environmental Protection
Horizon Center, P.O. Box 407
Robbinsville, New Jersey 08625-0407

With copy to

Deputy Attorney General, Section chief
Environmental Enforcement
Division of law
PO Box 93
25 Market St.
Trenton, NJ 08625-0093

As to Plaintiff-Intervener. the State of Oklahoma:

Eddie Terrill, Director
Air Quality Division
Oklahoma Department of Environmental Quality
P.O. Box 1677
Oklahoma City, OK 73101-1677

As to Plaintiff-Intervener the State of Texas:

John Steib
Deputy Director

Office of Compliance & Enforcement
Texas Commission on Environmental Quality
P.O. Box 13087, MC 172
Austin, TX 78711-3087

With a copy to:

Office of the Attorney General of the State of Texas
Natural Resource Division
ATTN: Karen Komell
300 West 15th Street, 10th Floor
Austin, Texas 78701
Or
PO Box 12548
Austin, Texas 78871-2548

As to Valero:

Mr. Norman Renfro, Vice President
Health Safety & Environment
Valero Energy Corporation
7990 West IH 10
San Antonio, TX 78230-4715

Richard Walsh, Esquire
Valero Energy Corporation
One Valero Place
San Antonio, TX 78212

Bart E. Cassidy, Esquire
Manko, Gold, Katcher & Fox, LLP
401 City Avenue, Suite 500
Bala Cynwyd, PA 19004

As to Tesoro:

Jeff Haffner, Esquire
Tesoro Petroleum Companies, Inc.
300 Concord Plaza Drive
San Antonio, TX 78216

Rob Gronewold
Corporate Environmental Affairs

Tesoro Petroleum Companies, Inc.
3450 S. 344th Way, Suite 201
Auburn, WA 98001-5931

377. All EPA and Plaintiff-Intervener approvals or comments required under this Decree shall be in writing.

378. Any party may change either the notice recipient or the address for providing notices to it by serving all other parties with a written notice setting forth such new notice recipient or address.

379. The information required to be maintained or submitted pursuant to this Consent Decree is not Subject to the Paperwork Reduction Act of 1980, 44 U.S.C. §§ 3501 et seq.

380. This Consent Decree shall be binding upon all Parties to this action, and their successors and assigns. The undersigned representative of each Party to this Consent Decree certifies that he or she is duly authorized by the Party whom he or she represents to enter into the terms and bind that Party to them.

381. Modification. This Consent Decree may be modified only by the written approval of the United States, the appropriate Plaintiff-Intervener and Valero or Tesoro, as applicable, or by Order of the Court. Additionally, it is anticipated that EPA, the appropriate Plaintiff-Intervener and Valero and Tesoro may reduce the frequency or nature of reporting overtime. Non-material modifications need not be filed with the Court to be effective, but material modifications shall be effective only upon filing with the Court. The United States will file non-material modifications with the Court on a periodic basis. For purposes of this Paragraph, non-material modifications include, but are not limited to, modifications to the frequency of reporting obligations and modifications to schedules that do not extend the date for compliance with

emission limitations following the installation of control equipment or the completion of a catalyst additive program, provided such changes are agreed upon in writing between EPA and Valero or Tesoro, as applicable.

382. Continuing Jurisdiction. The Court retains jurisdiction of this case after entry of this Consent Decree to enforce compliance with the terms and conditions of this Consent Decree and to take any action necessary or appropriate for its interpretation, construction, execution, or modification. During the term of this Consent Decree, any _____ may apply to the Court for any relief necessary to construe or effectuate this Consent Decree.

383. This Consent Decree constitutes the entire agreement and settlement between the Parties. Prior drafts of the Consent Decree shall not be used in any action involving the interpretation or enforcement of the Consent Decree.

So entered in accordance with the foregoing this _____ day of _____, 20__.

United States District Court Judge
for the Western District of Texas



FOR PLAINTIFF, UNITED STATES OF AMERICA:

KELLY A. JOHNSON
Acting Assistant Attorney General
Environment and Natural Resources Division
U.S. Department of Justice
950 Pennsylvania Avenue, N.W.
Washington, DC 20530-0001

Date _____

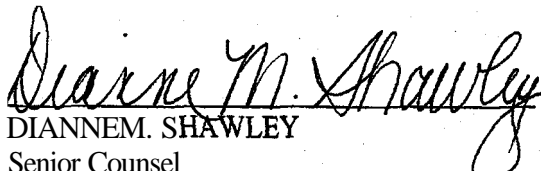
DIANNEM. SHAWLEY
Senior Counsel
Environment and Natural Resources Division
U.S. Department of Justice
1425 New York Avenue, N.W.
Washington, DC 20005

Date June 14, 2005

pm

FOR PLAINTIFF, UNITED STATES OF AMERICA:

Kelly A Johnson Date 6/15/05

KELLY A. JOHNSON
Acting Assistant Attorney General
Environment and Natural Resources Division
U.S. Department of Justice
950 Pennsylvania Avenue, N.W.
Washington, DC 20530-0001

Dianne M. Shaw Date June 9, 2005

DIANNE M. SHAW
Senior Counsel
Environment and Natural Resources Division
U.S. Department of Justice
1425 New York Avenue, N.W.
Washington, DC 20005

JOHNNY K. SUTTON
United States Attorney

By: *Drew B Biggs*

SU BIGGS
Assistant United States Attorney
Western District of Texas
601 N.W. Loop 410
Suite 600
San Antonio, TX 78216
Texas Bar No. 02312500
(210) 384-7255
(210) 384-7247 fax

FOR U.S. ENVIRONMENTAL PROTECTION AGENCY:

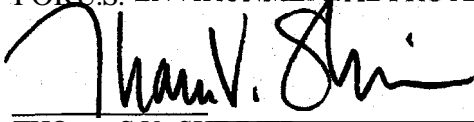

Date 6/14/05

THO S V. SKINNER

Acting Assistant Administrator
Office of Enforcement and Compliance
Assurance
U.S. Environmental Protection Agency
Ariel Rios Building
1200 Pennsylvania Avenue, N.W.
Washington, DC 20460

FOR PLAINTIFF-INTERVENER, THE STATE OF NEW JERSEY:

PETER C. HARVEY
ATTORNEY GENERAL OF NEW JERSEY

By:  6/3/05
SCOTT B. DUBIN
Deputy Attorney General
New Jersey Department of Law and Public Safety
Division of Law
RJ Hughes Justice Complex
25 Market Street
P.O. Box 093
Trenton, NJ 08625-0093
(609) 984-7141

BRADLEY M. CAMPBELL, COMMISSIONER
NEW JERSEY DEPARTMENT OF ENVIRONMENTAL PROTECTION

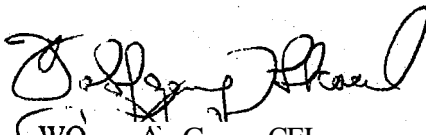
By:  6/2/05
W O A G C E L
Assistant Commissioner
Compliance and Enforcement
401 East State Street
P.O. Box 422
Trenton, NJ 08625

FOR PLAINTIFF-INTERVENER, THE STATE OF LOUISIANA

CHARLES C. FOTI, JR.
Attorney General

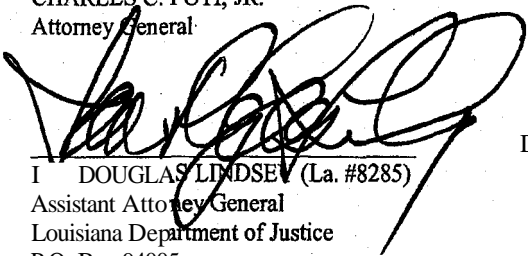
By: 

Date 10 Jan 05

DOUGLAS LINDSEY (La. #8285)
Assistant Attorney General
Louisiana Department of Justice
P.O. Box 94005
Baton Rouge, LA 70804-9005
Telephone: (225) 326-6400
Fax: (225) 326-6497

FOR PLAINTIFF-INTERVENER, THE STATE OF LOUISIANA, THROUGH THE DEPARTMENT OF ENVIRONMENTAL QUALITY:

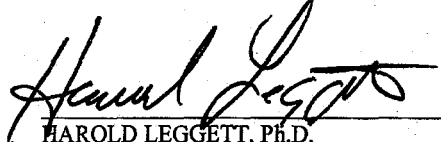

Date 6-10-05

HAROLD LEGGETT, Ph.D.
Assistant Secretary
Office of Environmental Compliance
Louisiana Department of Environmental Quality
P.O. Box 4312
Baton Rouge, LA 70821-4301

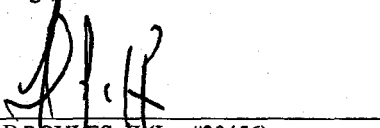

Date 6-10-05

TED R. ROYLES, II (La. #20456)
Attorney III
Office of the Secretary
Legal Affairs Division
Louisiana Department of Environmental Quality
P.O. Box 4302
Baton Rouge, LA 70821-4302

FOR PLAINTIFF-INTERVENER, THE STATE OF OKLAHOMA:

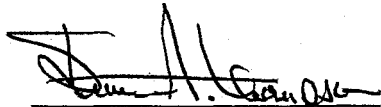
STEVE THOMPSON

Executive Director
Oklahoma Department of Environmental Quality
P.O. Box 1677
Oklahoma City, OK 73101-1677

Date: 6-9-05

FOR PLAINTIFF-INTERVENER, THE STATE OF TEXAS:

GREG ABBOTT
Attorney General of Texas

BARRY R. McBEE
First Assistant Attorney General

EDWARD D. BURBACH
Deputy Attorney General for Litigation

KAREN W. KORNELL
Assistant Attorney General
Chief, Natural Resources Division

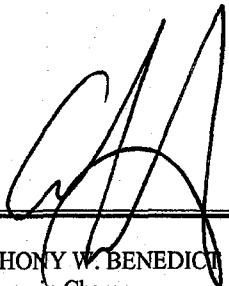

ANTHONY W. BENEDICT
Attorney in Charge
Assistant Attorney General
State Bar No. 02129100

Natural Resources Division
PO Box 12548, Capitol Station
Austin Texas 78711-2548

Tel: (512) 463-2012
Fax: (512) 320-0911

ATTORNEYS FOR THE STATE OF TEXAS

FOR PLAINTIFF-INTERVENER, THE STATE OF COLORADO

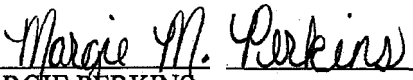

MARGIE PERKINS
Division Director, Air Pollution Control Division
Colorado Department of Public Health & Environment
APCD-ADM-B 1
4300 Cherry Creek Drive South
Denver, Colorado 80246-1530
Telephone: (303) 692-3115
Fax: (303) 782-5493

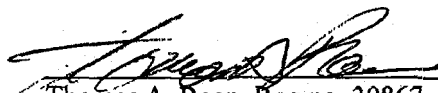
Date May 26, 2005

Thomas A. Roan, Reg no. 30867
Assistant Attorney General
Natural Resources and Environmental Section
1525 Shennan Street, 5th Floor
Denver, Colorado 80203
Telephone: (303) 866-5280
Fax: (303) 866-3558
Email: tom.roan@state.co.us

Date 6/6/05

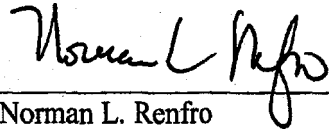
FOR DEFENDANTS - VALERO REFINING COMPANY - CALIFORNIA, VALERO REFINING COMPANY - NEW JERSEY, VALERO REFINING COMPANY - LOUISIANA, VALERO REFINING COMPANY - NEW ORLEANS, VALERO REFINING COMPANY - OKLAHOMA, VALERO REFINING - TEXAS, L.P., ULTRAMAR, INC., TPIPETROLEUM, INC., COLORADO REFINING COMPANY AND DIAMOND SHAMROCK REFINING COMPANY, L.P.



Date 5/2/05

Norman L. Renfro
P. O. Box 696000
San Antonio, TX 78269-6000
Telephone: (210) 345-2790
Fax: (210) 345-4976

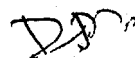

FOR DEFENDANT - TESORO PETROLEUM CORPORATION



Bill Aywood
Senior Vice President, Refining :
Tesoro Refining and Marketing Company

Date 5-9-05

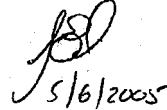

5/6/2005

D.15

SUMMARY OF ATTACHED APPENDICES

Appendix A	Refinery Descriptions
Appendix B	Heater and Boiler Initial Inventory
Appendix C	FCCD! Corpus Christi West HOC Maximum Coke Burn Rate
Appendix D	Alternative Monitoring Plans for NSPS Subpart J Refinery Fuel Gas Guidance
Appendix E	S02 Catalyst Additive Protocol
Appendix F	AG Flaring Logic Diagram
Appendix G	End-of-line Benzene NESHAP Sampling Plans
Appendix H	Reserved
Appendix I	Sustainable Skip Periods
Appendix J	Reserved
Appendix K	Acid Gas Flaring Devices
Appendix L	Regenerative Scrubber and Benicia WGS Design and Operation
Appendix M	Reserved
Appendix N	Hydrocarbon Flaring Devices
Appendix O	Specific Heater and Boiler NSPS Schedule
Appendix P	Supplemental and Beneficial Environmental Projects
Appendix Q	Schedule of Relevant Enforcement Matters
Appendix R	Mobile Source Provisions
Appendix S	PEM Requirements

APPENDIX A
REFINERY DESCRIPTIONS

ARDMORE REFINERY

The refinery, **currently** owned by TPI Petroleum, Inc., is **located** ninety (90) miles south of Oklahoma City just outside of the City of Ardmore, County of Carter, Oklahoma. The refinery **property** consists of approximately three hundred ninety (390) **acres**. The **address** of the **refinery** is Highway 142 Bypass and East Cameron Road, Ardmore, Oklahoma. The refinery is **bordered** on the south by Cameron Road and by Refinery Road to the west as shown generally in the attached plot diagram.



APPENDIX A
REFINERY DESCRIPTIONS

BENICIA REFINERY

The refinery, currently owned by Valero Refining Company - California, is located twenty-five (25) miles northeast of San Francisco in the industrial section of the City of Benicia, County of Solano, California. The refinery consists of approximately seven hundred sixty-five (765) acres. The physical address of the refinery is 3400 East Second Street, Benicia California. The refinery is bordered on the north by Bast Second Street and Interstate 680 to the South as shown generally in the attached plot diagram and aerial photo.

Don

APPENDIX A
REFINERY DESCRIPTIONS,

CORPUS CHRISTI EAST REFINERY

The refinery, currently owned by Valero Refining - Texas, .L.P., is located in the industrial section of Corpus Christi, Nueces County, Texas. The refinery consists of approximately five hundred thirty-two (532) acres. The physical address of the refinery is S900 Up River Road, Corpus Christi, Texas. The East plant property is located less than a half of a mile from the West plant property (described below), and is bordered by the Corpus Christi Ship Channel to the north and Up River Road to the south as shown generally on the attached plot diagram of the refinery. The refinery property is not contiguous with the West plant property and each has separate TCEQ regulated entity numbers and account numbers.

CORPUS CHRISTI REFINERY EAST PLANT COMPLEX 6-7 PLOT DIAGRAM

COMPLEX 7

COMPLEX 6

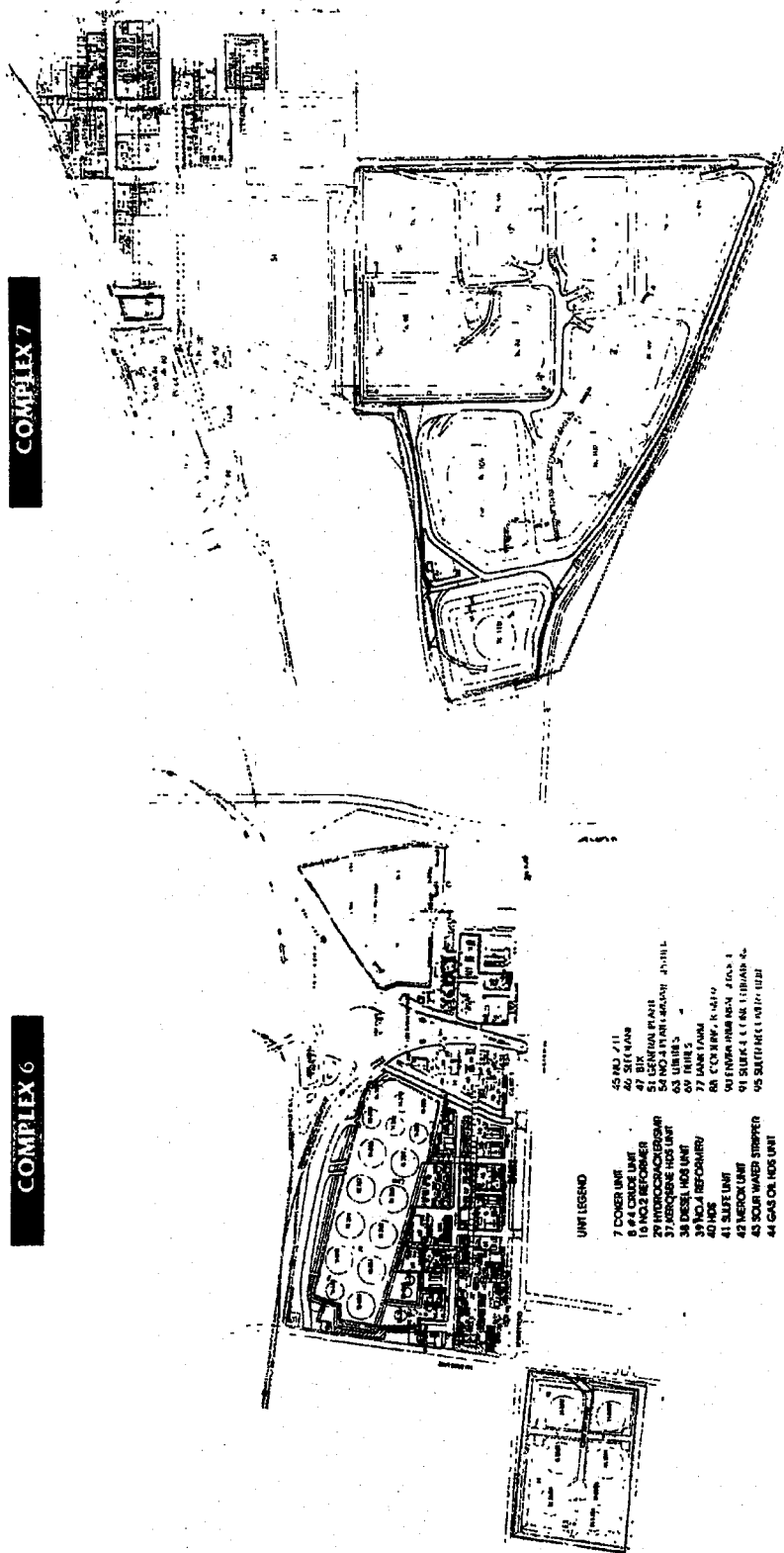

- UNIT LEGEND
- 7 DOWER UNIT
 - 8 #4 CRUDE UNIT
 - 16 HCL REFORMER
 - 29 HYDROCRACKER UNIT
 - 30 HYDROCRACKER UNIT
 - 34 FISSILE UNIT
 - 39 HCL REFORMER
 - 40 HDS
 - 41 SULFUR UNIT
 - 42 MERCAPTAN UNIT
 - 43 SOUR WATER STRIPPER
 - 44 GAS OIL HDS UNIT
 - 45 HCL UNIT
 - 46 STEEL UNIT
 - 47 STEEL UNIT
 - 54 NO. 4 FERTILIZER UNIT
 - 63 UNITS
 - 67 UNIT
 - 68 COCKING UNIT
 - 90 TOWER UNIT
 - 91 SULFUR UNIT
 - 95 SALT UNIT

Corpus Christi Refinery

D-37

APPENDIX A
REFINERY DESCRIPTIONS

CORPUS CHRISTI WEST, REFINERY

The refinery, **currently** owned by Valero **Refining** - Texas, L.P., is located in the industrial section of Corpus **Christi**, **Nueces** County, Texas. The refinery consists of approximately two hundred ~~sixty-seven~~ (267) **acres**. The physical **address** of the refinery is **S900** Up River Road, Corpus Christi, Texas and is bordered by the Corpus Christi. Ship **Channel** to the north and Up River Road to the **south** as shown generally on the **attached** plot **diagram** of the refinery. **The** refinery property is not contiguous with the East plant **property** and **each** has **separate** TCEQ regulated entity numbers and **account** numbers.

TERMINAL CRUISE LINE WEST

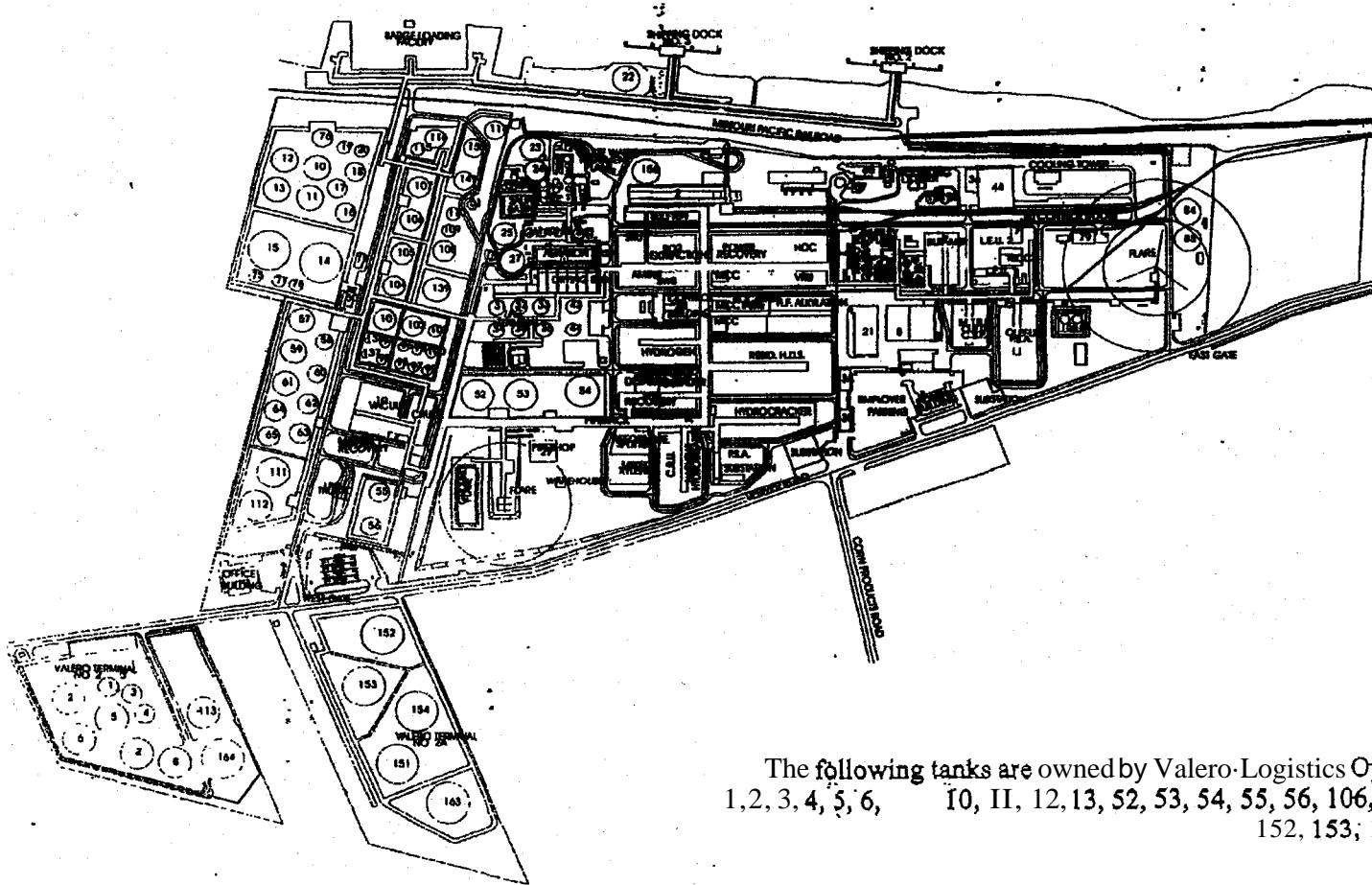

The following tanks are owned by Valero-Logistics Operations, L.P.:
 1, 2, 3, 4, 5, 6, 10, 11, 12, 13, 52, 53, 54, 55, 56, 106, 107, 113, 151,
 152, 153; 154, 163 & 164

DM

APPENDIX A
REFINERY DESCRIPTIONS

THE DENVER REFINERY

The refinery, currently owned by Colorado Refining Company, is located just north of Denver in Commerce City, County of Adams, Colorado. The refinery consists of approximately fifty-eight (58) acres. The physical address of the refinery is 5800 Brighton Blvd., Commerce City, Colorado and is bordered on the northwest by Brighton Blvd. and on the northeast by Interstate 270 as generally shown on the diagram of the refinery.

DENVER REFINERY PLOT DIAGRAM

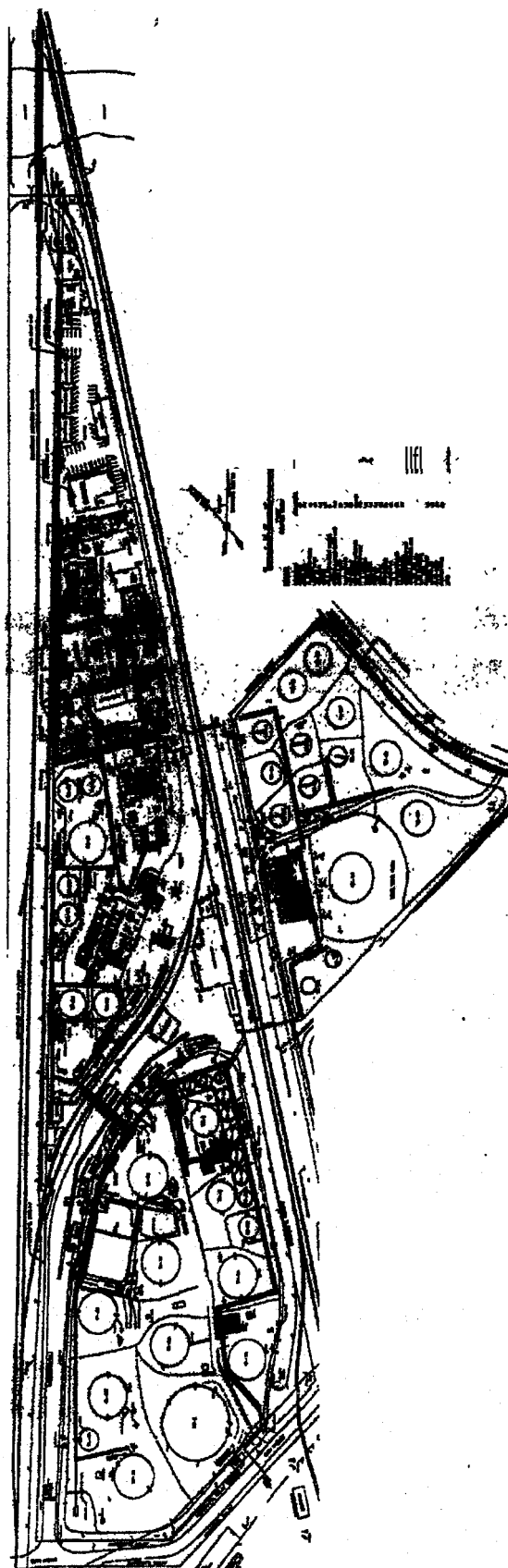

Don

APPENDIX A
REFINERY DESCRIPTIONS

GOLDENEAGLEREmNERY

The Tesoro Golden Eagle Refinery is located in the unincorporated area east of the City of Martinez, CA and north of the City of Concord, CA. The refinery is bounded on the west by Pacheco Slough, on the north by the Suisun Bay, on the south by Arnold Industrial Way, and on the east by Mallard Reservoir and the community of Clyde, CA. The developed portion of the refinery runs primarily along the east and west sides of Solano Way:

These facilities located within Tesoro boundaries are not part of the Golden Eagle Refinery: Air Liquide, Air Products Hydrogen Plant, Chevron Avon Terminal, Monsanto Company, Foster Wheeler Energy Corporation, Pacific Gas & Electric Avon Substation, Kinder Morgan Energy Partners, Texaco Metering Station, Southern Pacific Transportation, ConocoPhillips (Tank 241), Contra Costa Electric Satellite Shop, Royal Trucking (truck/transportation storage)



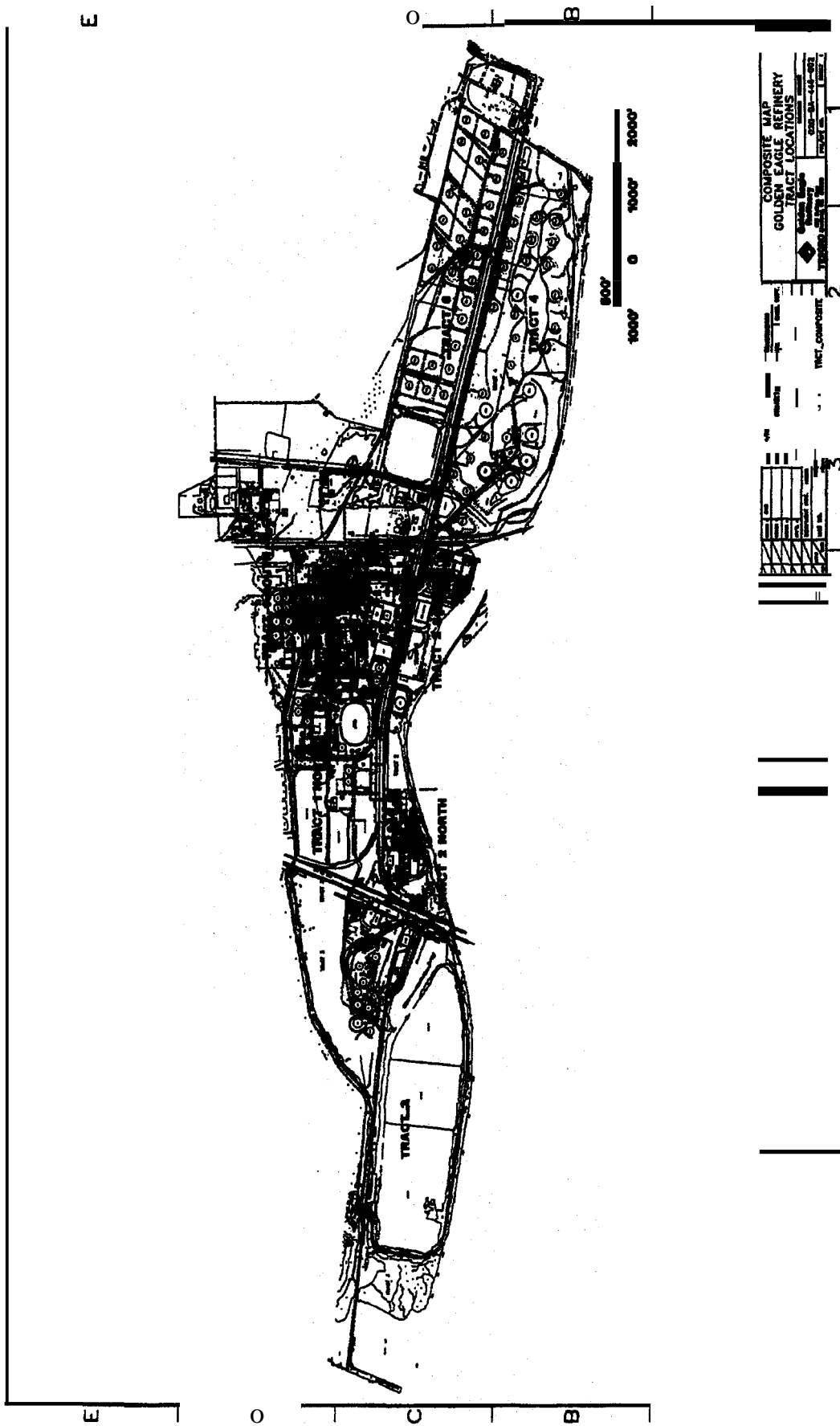

RSM

APPENDIX A
REFINERY DESCRIPTIONS

HOUSTON REFINERY

The refinery, **currently** owned by Valero Refining - **Texas**, L.P., is **located** on the Houston Ship **Channel** in Houston, **Harris** County, Texas. The refinery **consists** of approximately two **hundred** fifty (250) **acres**. The physical **address** of the refinery is 9700 Manchester Blvd., **Houston, Texas** and is bordered on the west. by 97th **Street**, on the south by Manchester Blvd. and on the northeast by the Houston Ship **Channel** as shown generally on the attached plot **diagram** of the refinery.

HOUSTON REFINERY PLOT DIAGRAM

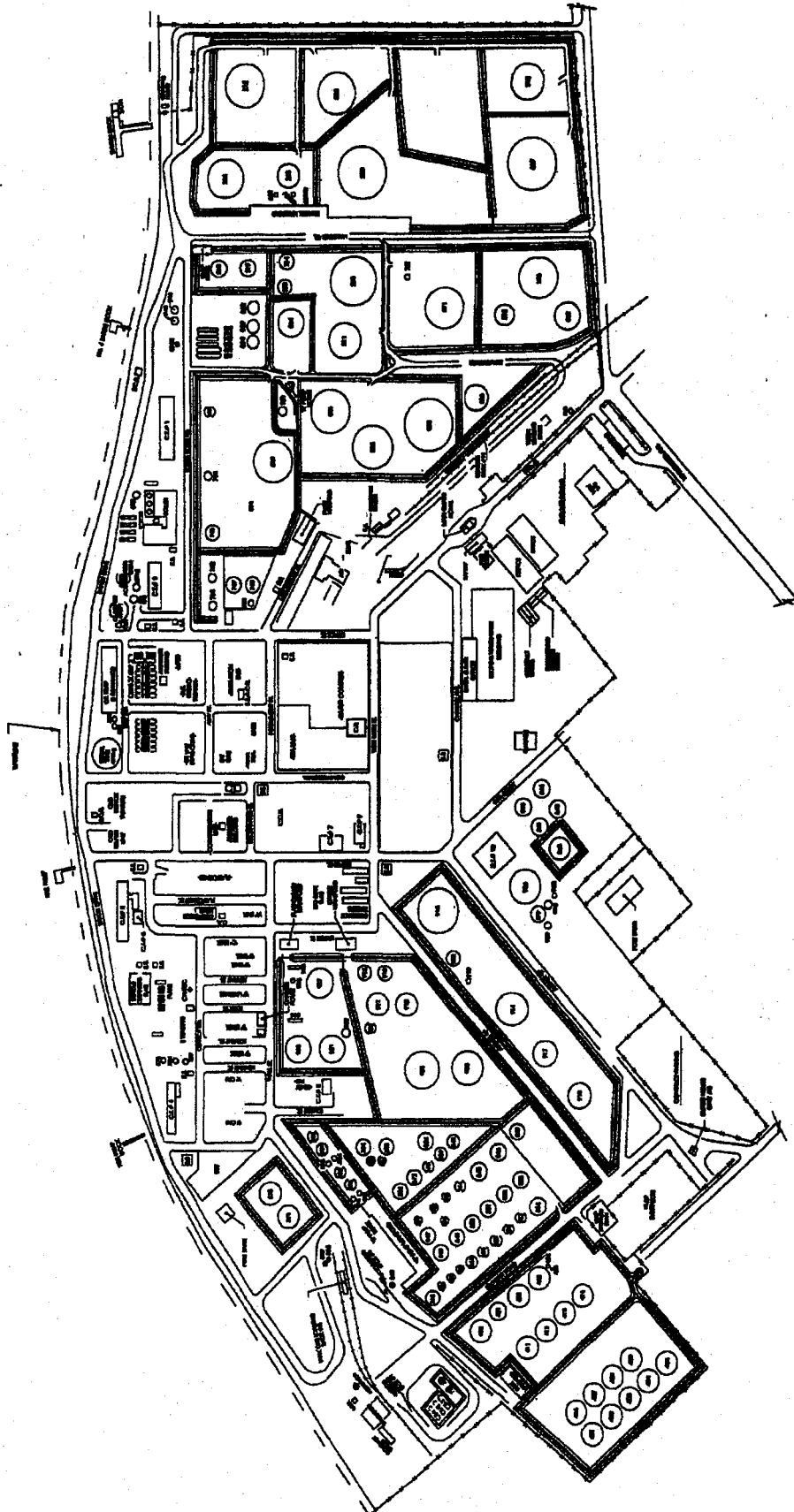

Houston Refinery

ADZ

APPENDIX A
REFINERY DESCRIPTIONS

KROTZ SPRINGS REFINERY

The refinery, currently owned by Valero Refining Company - Louisiana, is located approximately forty (40) miles northwest of Baton Rouge in Krotz Springs, St. Landry Parish, Louisiana. The refinery consists of approximately two hundred sixty-three (263) acres. The physical address of the refinery is Highway 105 South, **Krotz** Springs, Louisiana and is **bordered** to the east by the Atchafalaya River and Highway 105 as shown generally on the attached plot diagram of the refinery.

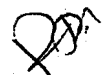

KROTZ SPRINGS REFINERY PLOT DIAGRAM

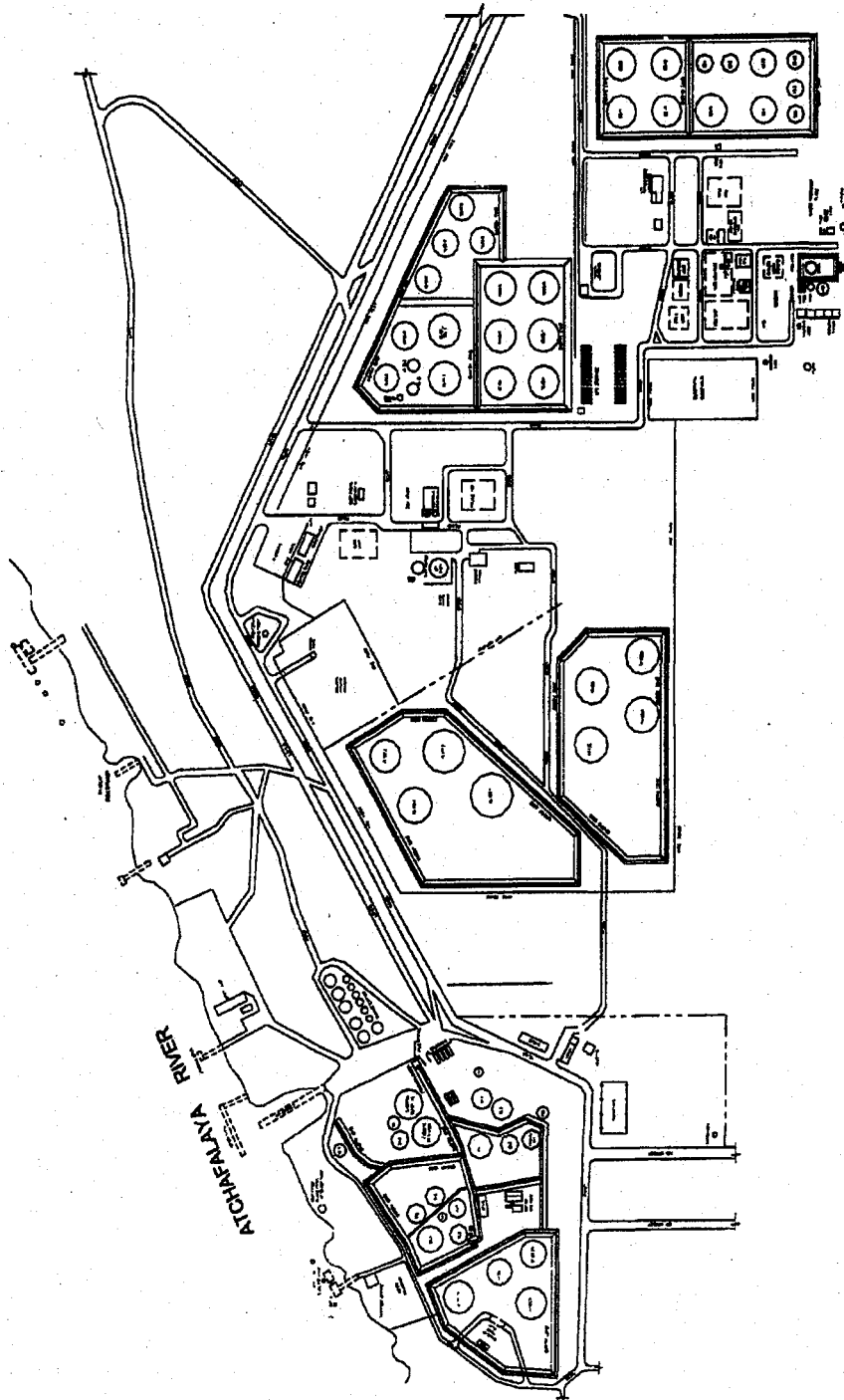

Krotz Springs Refinery

PH

APPENDIX A
REFINERY DESCRIPTIONS

MCKEEREFINERY

The refinery, currently owned by Diamond Shamrock Refining Company, L.P., is located just outside of Dumas, Texas, which is 45 miles North of Amarillo. The refinery is comprised of over three thousand (3,000) acres of land, which includes refinery operations and vacant lands surrounding the refinery. The physical address of the refinery is 6701 PM 119, Sunray, Moore County, Texas and is bordered to the south by PM 119 as shown generally on the attached plot diagram of the refinery.

APPENDIX A
REFINERY DESCRIPTIONS

PAULSBORO REFINERY

The refinery, currently owned by Valero Refining Company - New Jersey, is located approximately 15 miles south of Philadelphia in Paulsboro, ~~Gloucester~~ County, New Jersey. The refinery consists of approximately nine hundred fifty (950) acres. The physical address of the refinery is 800 Billingsport Road, Paulsboro, New Jersey and is ~~bordered~~ to the north by the Delaware River and to the southeast by Billingsport Road as shown generally on the attached plot diagram of the refinery.

PAULSBORO REFINERY PLOT DIAGRAM

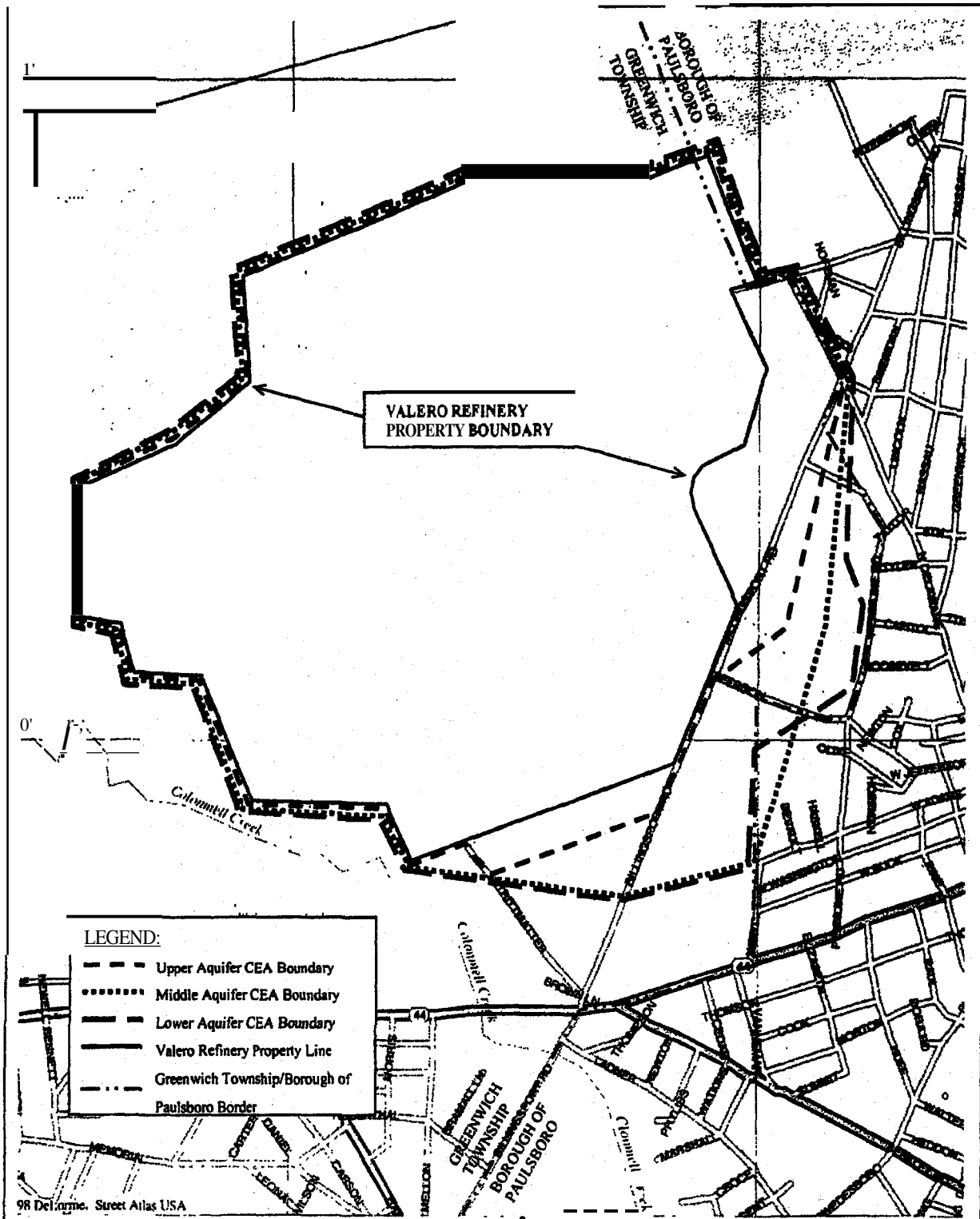

Ref: Paulsboro, NJ Delorme Street Atlas, USA.



Langan Engineering
and Environmental Services, Inc
Elmwood Park, NJ, Doylestown, PA, Philadelphia, PA
Miami, FL, New Haven, CT, New York, NY

**Valero Refinery
Classification Exception Area (CEA) Boundaries**

Date 12-6-00

Scale 1"=15,625'

Fig. 1

DM

APPENDIX A
REFINERY DESCRIPTIONS

ST. CHARLES REFINERY

The refinery, **currently** owned by Valero Refining - New Orleans, LLC, is located approximately **15** miles west of New Orleans in **Norco**, St. Charles parish, Louisiana. The refinery consists of approximately one thousand (1,000) **acres**. The physical **address** of the refinery is 14902 River Road, **Norco**, Louisiana and is bordered on the south by River Road and the Mississippi River and to the north by Airline Highway (US-61) as shown generally on the attached plotdiagram of the refinery.



ST. CHARLES REFINERY PLOT DIAGRAM

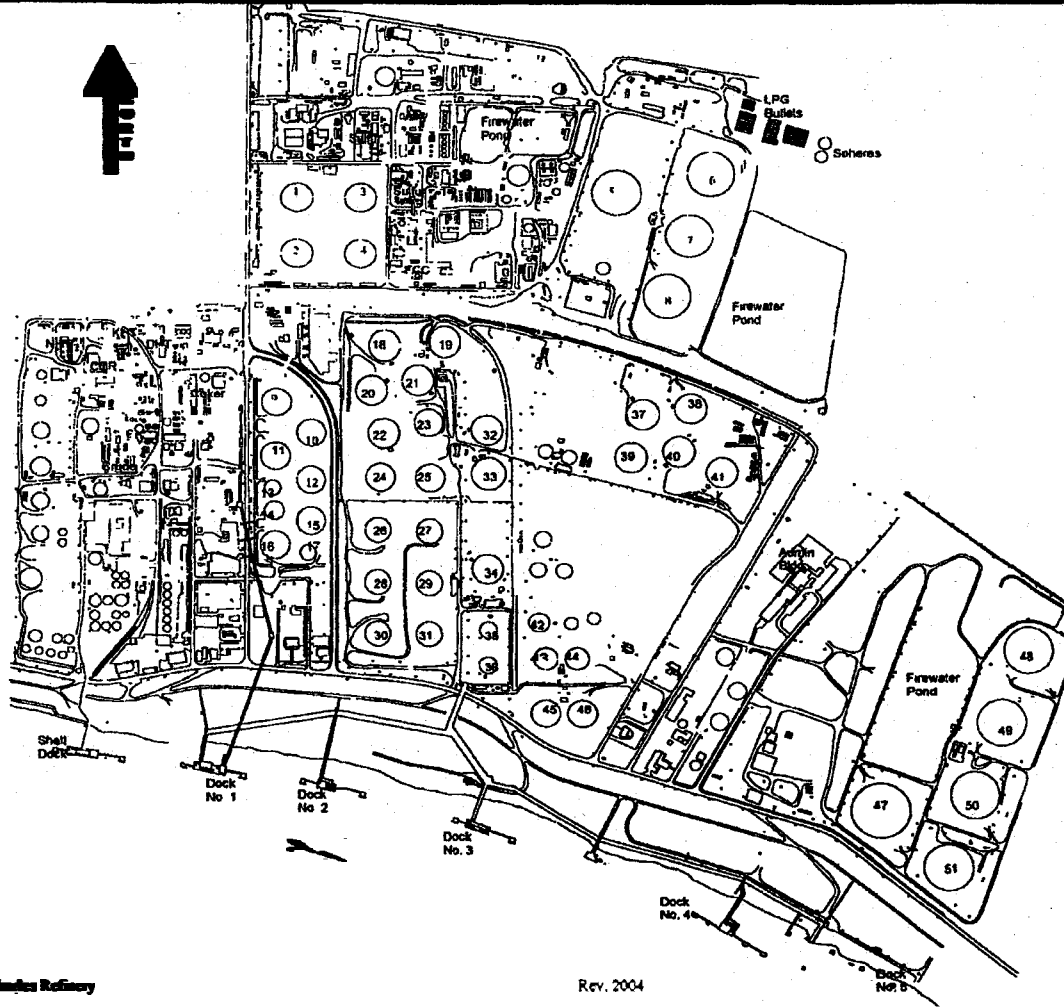

Plot Plan Tank Identification		
1	T150-14	Gasoline
2	T150-13	Gasoline
3	T150-16	Gasoline
4	T150-15	Diesel
5	T325-1	Gasoline
6	T325-4	No Product
7	T325-3	Gasoline
8	T325-2	Gasoline
9	T150-12	Diesel
10	T150-25	Gasoline
11	T150-23	Diesel
12	T150-26	Gasoline
13	T41-1	Gas Blend
14	T67-1	Gas Blend
15	T150-27	Reformate
16	T150-24	Gasoline
17	T45-2	Alkyline
18	T150-6	Resid
19	T150-8	Slurry
20	T150-5	Resid
21	T150-7	Slurry
22	T150-4	VGO(low)
23	T130-8	VGO(high)
24	T130-9	VGO(high)
25	T130-7	VGO(high)
26	T130-3	Crude
27	T130-6	Crude
28	T130-2	Crude
29	T130-5	Crude
30	T130-1	Crude
31	T130-4	No Product
32	T150-10	No Product
33	T175-1	VGO(low)
34	T150-3	LCO
35	T55-4	Mix
36	T55-5	VGO
37	T150-18	Crude
38	T150-19	Crude
39	T150-17	VGO(low)
40	T150-20	VGO(low)
41	T150-11	VGO(low)
42	T55-7	No Product
43	T80-3	Resid
44	T80-4	Mix
45	T150-1	LCO
46	T150-2	LCO
47	T625-1	Crude
48	T425-4	Resid(low)
49	T425-3	Resid
50	T425-2	Crude
51	T425-1	Crude

St. Charles Refinery

Rev. 2004

Page 15

APPENDIX A
REFINERY DESCRIPTIONS

TEXAS CITY REFINERY

The refinery, ~~currently~~ owned by Valero Refining - Texas, L.P., is ~~located~~ approximately forty-two (42) miles southeast of Houston in the industrial ~~section~~ of Texas City, Galveston County, Texas. The refinery consists of approximately two hundred ninety (290) ~~acres~~. The ~~physical~~ address of the refinery is 1301 Loop 197 South, Texas City, Texas and is bordered to the southeast by the Texas City Industrial, to the west by Texas City Port Blvd. (Loop 197) and to the north by Industrial Channel Road as shown generally on the ~~attached~~ plot diagram of the refinery.

TEXAS CITY REFINERY PLOT DIAGRAM

Handwritten signature

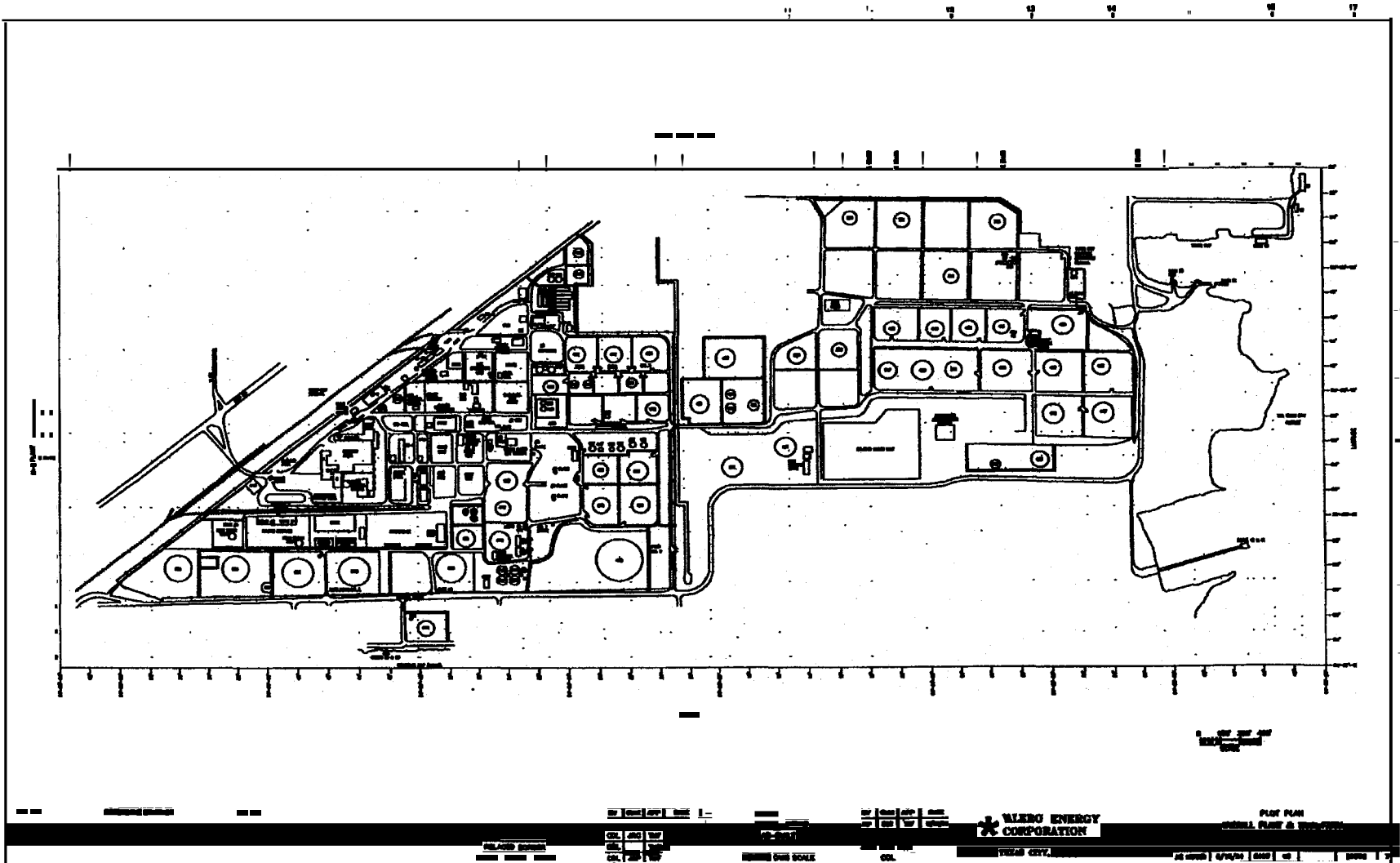

The following tanks are owned by Valero Logistics Operations, L.P.:
 79, 83, 84, 8S, 90, 91, 42S, 439, 496, 497, 510, 513 & 516

APPENDIX A
REFINERY DESCRIPTIONS

THREE RIVERS REFINERY

The refinery, currently owned by Diamond Shamrock Refining Company, L.P., is located approximately seventy-four (74) miles South of San Antonio in Three Rivers, Live Oak County, Texas. The refinery consists of approximately one thousand two hundred eighteen (1,218) acres, which includes the refinery operations and other properties owned by the refinery in Live Oak County. The physical address of refinery is 301 Le Roy Street, Three Rivers, Texas and is bordered on the west by Murray Ave. and to the east by Herman Ave. and is near the intersection of US Highway 281 and State Route 72 as shown generally on the attached diagram of the refinery.

DT2

THREE RIVERS REFINERY PLOT DIAGRAM

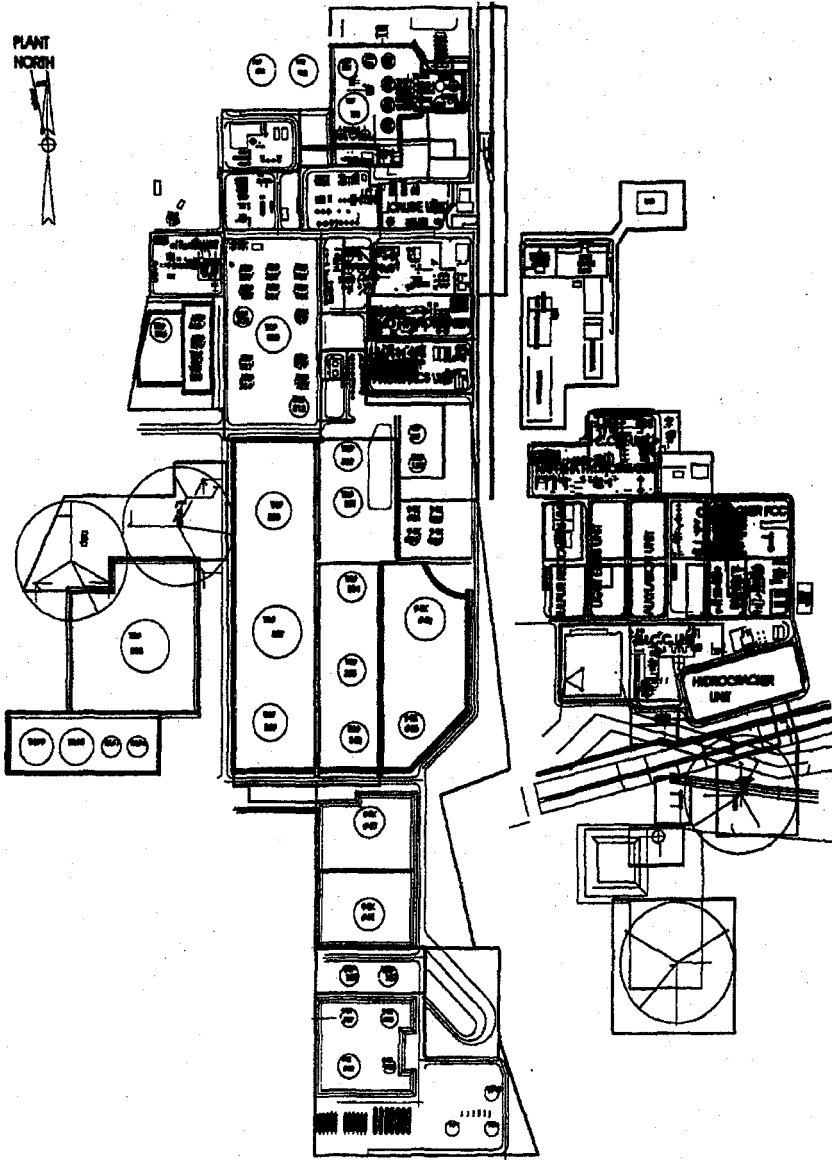

Three Rivers Refinery

DM

APPENDIX A
REFINERY DESCRIPTIONS

WILMINGTON REFINERY

The refinery, currently owned by Ultramar Inc., is ~~located~~ approximately twenty-one miles south of Los Angeles in ~~Wilmington~~, County of Los Angeles, California and is near the City of Long Beach. The refinery consists of approximately one hundred forty-eight (148) ~~acres~~. The physical ~~address~~ of the refinery is 2402 East Anaheim, ~~Wilmington~~, Los Angeles County, California and is bordered on the north by Anaheim Street, the Dominguez Channel to the west and the Terminal Island Freeway to the to the south as shown ~~generally~~ in the ~~attached~~ plot ~~diagram~~ of the refinery.

WILMINGTON REFINERY PLOT DIAGRAM

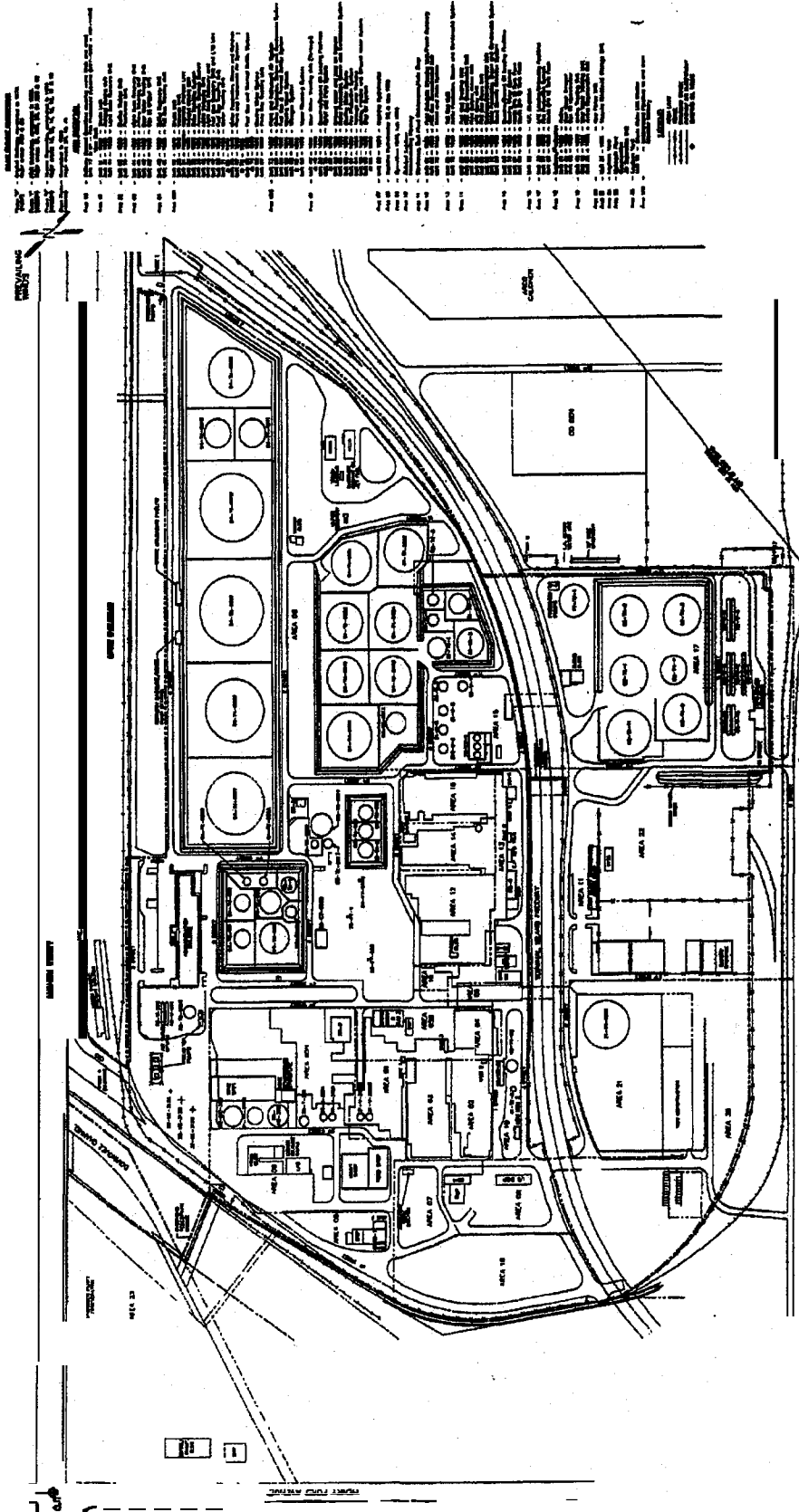

Handwritten signature or initials

APPENDIXB

Initial Inventory of Covered Heaters and Boilers

Source Name	Description	Heat Input Capacity (HHV) MMBTU/HR	Source of Heat Input Capacity	NOx Lb/MMBTU	NOx CEMS Installed
Ardmore					
H-15001	Hydrogen Unit Feed Preheater	████	Permit	████	
H-102A	Crude Unit Preheater	████	Permit	████	
H-102B	Crude Unit Preheater	████	Permit	████	
H-603	DHDS Unit Fractionating Tower Reboiler	████	Permit	████	
H-201	FCCU Feed Preheater	████	Permit	████	
H-403	Platformer Unit Reactor #2 Preheater	████	Permit	████	
H-404 H-405	Platformer Unit Reactor #1 Preheater Platformer Unit Reactor #3 Preheater	████ ████	Permit	████	
H-103	Vacuum Tower Preheater	████	Permit	████	
H-6501	CFHT Unit Reactor Feed Preheater	████	Permit	████	
B-802	Plant Utility Steam Generator /Boiler	████	Permit	████	
B-803	Plant Utility Steam Generator IBoiler	████	Permit	████	
B-801	Plant Utility Steam Generator /Boiler	████	Permit	████	
H-901	Alkylation Unit IsoStripper Reboiler	████	Permit	████	
H-601	DHDS Unit Reactor Feed Preheater	████	Permit	████	
H-6502	CFHT Unit Fractionating Twr Preheater	████	Permit	████	
McKee					
H-1	No. 1 Crude Charge Heater	████	Permit	████	
H-41	No.2 Crude Charge Heater (Born)	████	Permit	████	Yes
H-18/1 H-18/2 H-18/3	No. ICCR Charge Heater 1 No. I CCR Charge Heater 3 No.1 CCR Charge Heater 4	████ ████ ████	Permit	████	Yes
B-12	600# Boiler	████	Permit	████	
B-10	No. 18 Boiler	████	Max	████	
B-11	No. 19 Boiler	████	Max	████	
H-21	No. 1 NH3 Primary Reformer Heater	████	Max	████	

Source Name	Description	Heat Input Capacity (HRY) MMBTU/HR	Source of Heat Input Capacity	NOx Lb/MMBTU	NOx CEMS Installed
H-38/1 H-38/2 H-38/3	No.3 Reformer ChgHtr 1 (New #2 Ref.) No.3 Reformer ChgHtr 2 (New #2 Ref.) No.3 Reformer ChgHtr 3 (New #2 Ref.)	█	Permit	█	
H-46	No.1 CCR RefChg Heater 2 (#1 Interhtr)	█	Permit	█	
B-8	No. 15 Boiler	█	Max	█	
B-9	No. 16 Boiler	█	Max	█	
B-4	No.11 Boiler	█	Max	█	
B-5	No. 12 Boiler	█	Max	█	
B-6	No. 13 Boiler	█	Max	█	
B-7	No. 14 Boiler	█	Max	█	
H-26	No.2 Vacuum Heater	█	Permit	█	
B-3	No. 10 Boiler (standby)	█	Max	█	
H-8	HCV Fractionation Rtr (N. PetroChem)	█	Permit	█	
H-11	No.2 Crude Charge Heater	█	Permit	█	
H-45	No. 1 Hydrotreater Charge Heater	█	Permit	█	
H-42	HCV Recycle Heater	█	Permit	█	
H-43	HCV DeC4 Reboiler Heater	█	Permit	█	
H-2	No.1 Vacuum Charge Heater	█	Permit	█	
H-36	No.4 Hydrotreater ChgHtr (New #2 H.T.)	█	Permit	█	
H-40	No. 1 PDA Asphalt Heater	█	Permit	█	
H-48	Diesel HOV Charge Heater	█	Permit	█	
H-3	No.1 Naphtha Reboiler Heater	█	Permit	█	
H-9	No.2 Crude Heater (S. PetroChem)	█	Permit	█	
H-13	Gas Oil Fractionator Charge Heater	█	Permit	█	
H-37	No.2 Hydrotreater Reboiler	█	Permit	█	
H-39	No.2 Reformer Stab. Reboiler	█	Permit	█	
Wilmington					
70-H-1	Reformer Heater	█	Permit		Yes
70-H-2	Reformer Heater	█	Permit		Yes
70-H-3	Reformer Heater	█	Permit		Yes
56-H-2	Naphtha HDT Heater	█	Permit		Yes
10-H-I00	#1 Crude Heater	█	Permit		Yes
30-H-301	#1 Coker Heater	█	Permit		Yes

Source Name	Description	Heat Input Capacity (HHV) MMBTU/HR	Source of Heat Input Capacity	NOx Lb/MMBTU	NOx CEMS Installed
11-H-1000	#2 Crude Heater	█	Permit		Yes
86-B-9001	Boiler	█	Permit		Yes
58-H-1	HDS Recycle Heater	█	Permit		Yes
31-H-3000	#2 Coker Heater	█	Permit		Yes
80-H-2	GOH Charge Heater	█	Permit		Yes
68-H-1	Alky Heater	█	Permit		Yes
20-H-200	Vacuum. Feed Heater	█	Permit		Yes
86-B-9000	Boiler	█	Permit		
Three Rivers					
B-007	BTX Boiler	█	Permit	█	
H-030/1 H-030/3 H-030/4	No.2 Reformer Charge Heater No.2 Reformer Charge Heater No.2 Reformer Charge Heater	█	Permit	█	
B-004 B-004	Boiler 6F1-A Boiler 6F1-B	█	Permit	█	
H-028	No. 1 Crude Charge Heater	█	Permit	█	
H-036	No.1 Crude Charge Heater	█	Permit	█	
H-012/204 H-012/205A	No. 1 Reformer Charge Heater No.1 Reformer Charge Heater	█	Permit	█	
H-032	No.2 Reformer Charge Heater	█	Permit	█	
H-016	Vacuum. Charge Unit Heater	█	Permit	█	
B-006	East Plant Boiler	█	Permit	█	
H-035	HCU Debutanizer Reboiler	█	Permit	█	
B-009	Steam Boiler (new)	█	Permit	█	
H-014	Naphtha Splitter Reboiler	█	Permit	█	
H-044	Reformate Reboiler Heater	█	Permit	█	
H-020	Alky Iso stripper Reboiler Htr	█	Permit	█	
B-005	Boiler SP-5	█	Permit	█	
H-034	HCV Recycle Heater	█	Permit	█	
H-037	No.2 HDU Charge Heater	█	Permit	█	
H-040	Steam/Methane Reformer Htr.	█	Permit	█	
H-038	No.2 HDU Reboiler Heater	█	Permit	█	
H-041	F-2201 DMD HTH2 Recycle	█	Permit	█	
Denver					
04-H-401 04-H-402	Reformer Heater Reformer Heater	█	Max	█	
01-H-101	Crude Heater	█	Max	█	
51-B-501	Boiler #1	█	Max	█	

D&W

Source Name	Description	Heat Input Capacity (HHV) MMBTU/HR	Source of Heat Input Capacity	NOx LblMMBTU	NOx CEMS Installed
51-B-502	Boiler #2	█	Max	█	
51-B-503	Boiler #3	█	Max	█	
02-H-201	FCCU PreHeater	█	Max	█	
Benicia					
F301	H2 Reforming Furnace	█	Permit	█	Yes
F351	H2 Reforming Furnace	█	Permit	█	Yes
F2901-4(2)	Powerfonner Furnace	█	Max	█	Yes
F4460	MRVHotOil Furnace	█	Permit	█	Yes
SG 1032	New Boiler	█	Permit	█	Yes
F701	FCCU Preheat Furnace	█	Max	█	Yes
SG2301	Utility Package Boiler	█	Permit	█	Yes
SG2302	Utility Package Boiler	█	Max	█	Yes
F401	HCV Recycle Gas Furnace	█	Permit	█	Yes
SG2901	Powerfonner Aux. Boiler	█	Max	█	
SG703	FCCU Aux. Boiler	█	Max	█	
F2905	Powerformer Regen Furnace	█	Max	█	
F104	Naphtha HF Furnace	█	Max	█	
F103	Pipestill HF Jet Furnace	█	Max	█	
Corpus West					
13-H-01 A	SMR Primary Reformer	█	Permit	█	Yes
13-H-01 C	SMR Aux. Boiler	█	Permit	█	Yes
13-H-01 B	SMR Super Heater	█	Permit	█	Yes
30-B-01	Corn Products Boiler	█	Permit	█	
30-B-03	BUPBoiler	█	Permit	█	Yes
30-B-02	HRBoiler	█	Permit	█	Yes
38-H-01	Oleflex Charge Heater	█	Permit	█	Yes
38-H-02	Oleflex Interheater	█	Permit	█	Yes
38-H-03	Oleflex Interheater	█	Permit	█	Yes
01-H-01	Crude Heater	█	Permit	█	Yes
49-H-02	CRV No. 1 Interheater	█	Permit	█	Yes
49-H-04	CRU No.3 Interheater	█	Permit	█	Yes
49-H-01	CRU Charge Heater	█	Permit	█	Yes
49-H-03	CRU No.2 Interheater	█	Permit	█	Yes
49-H-91	C8 Splitter Reboiler	█	Permit	█	Yes
49-H-90	C7 Splitter Reboiler	█	Permit	█	Yes
02-H-01	Vacuum Heater	█	Permit	█	
31-H-01	AlkyFrac Reboiler	█	Permit	█	
11-H-01	Desalter Heater	█	Permit	█	

Source Name	Description	Heat Input Capacity (HHY) MMBTU/HR	Source of Heat Input Capacity	NOx LblMMBTU	NOx CEMS Installed
47-H-04	Hydrocracker Frac Reboiler	█	Permit	█	
47-H-01	Hydrocracker RX-OI Heater	█	Permit	0 █	
49-H-71	Reformate Splitter Heater	█	Permit	█	
12-H-OI A 12-H-OI B	HDS Heater HDS Heater	█	Permit	█	
Corpus East					
EP-B-5	EP Boiler #5	█	Max	█	
39-H-3/A	WP #4 Platformer Charge	█	Max	█	
39-H-3/B	WP #4 Platformer Charge	█	Max	█	
8-H-6	WP #4 Crude Chrg. (H6)	█	Max	█	
QIO-H-OI	QP SMR Heater	█	Max	█	
8-H-4	WP #4 Crude Chrg. (H4)	█	Max	█	
QH-125 QH-125 QH-125	#2 Reformer Heater Reactor #1 #2 Reformer Heater Reactor #2,3 #2 Reformer Heater Reactor #4,5	█	Max	█	
EP-B-1	EP Boiler #1	█	Max	█	
EP-B-2	EP Boiler #2	█	Max'	█	
7-H-2	WP Delayed Coker Chrg.	█	Max	█	
B-4	IQP West Boiler	█	Max	█	
B-5	QP East Boiler	█	Max	█	
44-H-1	WPGOT Chrg.	█	Max	█	
24-H-1	EP #2 HDA Rx Chrg.	█	Max	█	
WP-B-14	WP Boiler #14	█	Max	█	
12-H-1	EP FCCU Raw Oil Chrg.	█	Max	█	
8-H-5	WP #4 Vacuum Chrg. (H5)	█	Max	█	
23-H-1	EP Nonene Hot Oil Htr	█	Max	█	
8-H-1	Crude Vacuum Backup	█	Max	█	
8-H-2	Crude Vacuum Backup	█	Max	█	
10-H-8	EP Visbreaker Chrg Htr @ SS	█	Max	█	
QL-10	QP Deoct. Reboiler (#4 Plat Splitter)	█	Max	█	
QII-H-301	QPHCU Rx Chrg.	█	Max	█	
26-H-2	Toluene Col 2 Heater	█	Max	█	
44-H-2	WPGOT Frac. Reb.	█	Max	█	
39-H-1	WP #4 Hydrobon Chrg.	█	Max	█	
39-H-7	WP #4 Plat. Stab. Reb.	█	Max	█	
8-H-3	WP #4 Vacuum Chrg. (H3)	█	Max	█	
Q3-H-4	QP #2 Reformate Splitter	█	Max	█	
Texas City					

D.J.

Source Name	Description	Heat Input Capacity (HHV) MMBTUIHR	Source of Heat Input Capacity	NOx Lb/MMBTU	NOx CEMS Installed
HeaterH-44	ROSE Heater	█	Permit	█	Yes
Boiler B-18	Utilities Boiler	█	Permit	█	Yes
Heater H-16	No.3 Crude Heater	█	Permit	█	Yes
Boiler B-11	Utilities Boiler	█	Permit	█	
HeaterH-8	No. 1 Reformer Heater	█	Permit	█	
HeaterH-39	Residfiner TG Train 1	█	Permit	█	
HeaterH-40	Residfiner TG Train 2	█	Permit	█	
HeaterH-1	Toppers Heater	█	Permit	█	
HeaterH-34	Toppers (A-76) Heater	█	Permit	█	
HeaterH-2	Toppers Heater	█	Permit	█	
HeaterH-28	Alkylation Unit	█	Permit	█	Yes
Heater H-38	Residfiner Feed Prep	█	Permit	█	
Heater H-17	No.3 Crude Heater	█	Permit	█	Yes
HeaterH-41	Residfiner Fractionator	█	Permit	█	
HeaterH-50	DHT Heater	█	Permit	█	
HeaterH-21	No.2 Reformer Heater	█	Permit	█	
HeaterH-20	No.2 Reformer Heater	█	Permit	█	
HeaterH-29	RVDUHeater	█	Permit	█	
Heater H-22	No.2 Reformer Heater	█	Permit	█	
HeaterH-19	No.2 Reformer Heater	█	Permit	█	
HeaterH-32	MDHTHeater	█	Permit	█	
HeaterH-18	No.2 Reformer Heater	█	Permit	█	
Heater H-23	No.2 Reformer Heater	█	Permit	█	
Houston					
23BC201	Comb. Atm. Tower Furnace N.	█	Max	█	Yes
81BF7	Boiler 7	█	Max	█	
81BF12	Boiler 12	█	Max	█	
81BF14	Boiler 14	█	Max	█	
81BF15	Boiler 15	█	Max	█	
81BF16	Boiler 16	█	Max	█	
27BAI105	Platformer Rerun Reb.	█	Max	█	
23BA301	Comb. Vac Tower Furnace (West)	█	Max	█	
27BAI100	Platformer Rx. Chg. Htr.	█	Max	█	
44BA3002	ROSE Hot Oil Htr.	█	Max	█	
29BA1300	B Unifiner Rx. Chg. Furnace	█	Max	█	
37BA301	Pseudocumene Reboiler	█	Max	█	
23BA302	Vacuum Tower Htr. (East)	█	Max	█	
27BAI103	Platformer Rx. Htr. #1	█	Max	█	
Krotz					

Source Name	Description	Heat Input Capacity (HHV) MMBTU/HR	Source of Heat Input Capacity	NOx Lb/MMBTU	NOx CEMS Installed
Springs					
B-8203	FCC Boiler	█	Permit	█	
H-2301	Crude Heater	█	Permit	█	
H-2302	Vacuum Heater	█			
B-8202	FCC Boiler	█	Permit	█	
H-2001	Reformer Charge Heater	█	Permit	█	
B-8003	Isomerization Boiler	█	Permit	█	
B-8201	MTBE Boiler	█	Permit	█	
H-4201	FCC Charge Heater	█	Permit	█	
B-8002	Crude Holman Boiler	█	Permit	█	
B-8001	Crude Zum Boiler	█	Permit	█	
Paulsboro					
Boiler A	Boiler A	█	Permit	█	Yes
Boiler B	Boiler B	█	Permit	█	Yes
BoHerC	BoilerC	█	Permit	█	Yes
PtR BIOI	PtR BIOI	█	Permit	█	
CU6	CU6	█	Permit	█	
CU7F2	CU7F2	█	Permit	█	
CHDI	CHDI	█	Permit	█	
CU7F1	CU7F1	█	Permit	█	
CokerA	Coker A	█	Permit	█	
CokerB	CokerB	█	Permit	█	
CU7FIA	CU7FIA	█	Permit	█	
PtR B102/103	PtR B102/103	█	Permit	█	
H2 Plant	H2 Plant	█	Permit	█	
PtRBI	PtRBI	█	Permit	█	
Furf1 BBI	Furf1 BBI	█	Permit	█	
Furf2 BIOI	Furf2 BIOI	█	Permit	█	
PDABB2	PDABB2	█	Permit	█	
MLDW	MLDW	█	Permit	█	
St.Charies					
F-72-703	Crude Heater	█	Permit	█	
F-53-1A	CokerHeater A	█	Permit	█	
F-53-1B	CokerHeater B				
F-53-1C	CokerHeater C				
F-53-1D	CokerHeater D				
B401C	Boiler	█	Permit	█	
B401D	Boiler	█	Permit	█	

7

Source Name	Description	Heat Input Capacity (BHY) MMBTUIHR	Source of Heat Input Capacity	NOx LblMMBTU	NOx CEMS Installed
F-52-1B	Vacuum Heater	█	Permit	█	
F-701	Crude Heater	█	Permit	█	
F-52"1A	Vac Heater (F-52-1A/B limit is 406 MM)	█	Permit	█	
F-704	Crude Heater	█	Permit	█	
B-804	Boiler	█	Permit	█	
B-19-04	Boiler	█	Permit	█	
B-19-03	Boiler	█	Permit	█	
F-33-01	KHT Heater	█	Permit	█	
15-02	DHTHeater	█	Permit	█	
H-39-02	NHTHeater	█	Permit	█	
F-33-02	KHT Heater	█	Permit	█	
H-39-01	NHT Heater	█	Permit	█	
H-15-01A	DHTHeater	█	Permit	█	
H-15-01B	DHTHeater	█	Permit	█	
H-39-03	NHTHeater	█	Permit	█	

This table includes existing heaters and boilers as of 1999-2000 with a capacity greater than 40 MMBTUIHR (HHV).

- Heaters/boilers combined into one emission rate have common stacks.
- Benicia heaters are deemed to have fixed NOx rate of 0.033 lb/MMBTU based on BAAQMD requirement
- The NOx emission level is either an explicit permit limit or implied permit limit based on allowable firing rate and NOx emissions, if available, or estimated NOx if no permit limit exists.

This data is Confidential Business Information

27

APPENDIX C
Initial FCCU Annual Maximum Coke Burn Rates

<u>Refinery</u>	<u>Annual FCCU Maximum Coke Burn lb/hr</u>
Ardmore	[REDACTED]
Corpus Christi East	[REDACTED]
Corpus Christi West	[REDACTED]
Denver	[REDACTED]
Houston	[REDACTED]
Krotz Springs	[REDACTED]
McKee	[REDACTED]
Paulsboro	[REDACTED]
St. Charles	[REDACTED]
Texas City	[REDACTED]
Three Rivers	[REDACTED]
Wilmington	[REDACTED]
Golden Eagle	[REDACTED]

This data is Confidential Business Information

[Handwritten mark]

APPENDIX DALTERNATIVE MONITORING PLAN
for NSPS Subpart J Refinery Fuel GasConditions for Approval of the Alternative Monitoring Plan for Miscellaneous Refinery Fuel Gas Streams

Refinery fuel gas streams/systems eligible for the Alternative Monitoring Plan (AMP) should be inherently low in H₂S content, and such H₂S content should be relatively stable. The refiner requesting an AMP should provide sufficient information to allow for a determination of appropriateness of the AMP for each gas stream/system requested. Such information should include, but need not be limited to:

- A description of the stream/system to be considered including submission of a portion of the appropriate piping diagrams indicating the boundaries of the gas stream/system, and the affected fuel combustion device(s) to be considered and an identification of the proposed sampling point for the alternative monitoring;
- A statement that there are no crossover or entry points for sour gas (high H₂S content) to be introduced into the gas stream/system. (This should be shown in the piping diagrams);
- An explanation of the conditions that ensures low amounts of sulfur in the gas stream (i.e., control equipment or product specifications) all times;
- The supporting test results from sampling the requested gas stream/system using appropriate H₂S monitoring (i.e., detector tube monitoring following the Gas Processor Association's: Test for Hydrogen Sulfide and Carbon Dioxide in Natural Gas Using Length of Stain Tubes, 1986 Revision), at minimum:
 - for frequently operated gas streams/systems - two weeks of daily monitoring (14 samples);
 - for infrequently operated gas streams/systems, 7 samples shall be collected unless other additional information would support reduced sampling.

Note: All samples are grab samples.

- A description of how the two weeks (or seven samples for infrequently operated gas streams/systems) of monitoring results compares to the typical range of H₂S concentration (fuel quality) expected for the gas stream/system going to the affected gas combustion device. (e.g., The two weeks of daily detector tube results for a frequently operated loading rack included the entire range of products loaded and, therefore, should be representative of typical operating conditions affecting H₂S content in the gas stream going to the loading rack flare);
- Identification of a representative process parameter can function as an indicator of a stable and low H₂S concentration for each fuel gas stream/system, (e.g., review of gasoline sulfur content as an indicator of sulfur content in the vapors directed to a loading rack flare);
- Suggested process parameter limit for each stream/system, the rationale for the parameter limit and the schedule for the acquisition and review of the process parameter data. The refiner will collect the proposed process parameter data in conjunction with the testing of the fuel gas stream's stable and low H₂S concentration.

The following shall be used for measuring H_2S in fuel gas within these types of AMPs unless the refiner requests, in writing, for approval of an alternative methodology:

- Conduct H_2S testing using detector tubes ("length-of-stain tube" type measurement);
- Detector tube ranges Q-10/O-100 ppm (N=1011) shall be used for routine testing; and
- Detector tube ranges 0-500 ppm shall be used for testing if measured concentration exceeds 100 ppm H_2S .

Data Range and Variability Calculation and Acceptance Criteria

For each step of the monitoring schedule, sample range and variability will be determined by calculating the average plus 3 standard deviations for that test dataset.

- If the average plus 3 standard deviations for the test data set is less than 81 ppm H_2S , the sample range and variability are acceptable and the refiner can proceed to the next of the monitoring schedule.

Note: 81 ppm is one-half the maximum allowable fuel gas standard under NSPS Subpart J, and the Agency believes that using 81 ppm acceptance criteria provides a sufficient margin for ensuring that the emission limit is not exceeded under nonnal operating conditions.

- If the data shows an unacceptable range and variability at any step (the average plus 3 standard deviations is equal to or greater than 81 ppm H_2S), then move to Step 7. Agency approval is required to proceed to the next step if the average plus 3 standard deviations is between 81 ppm and 162 ppm H_2S . As an example, approval may be granted based on a review of the test data and any pertinent information which demonstrates that sample variability during the test period was due to unusual circumstances. Supplemental test data may be taken to demonstrate that process variability is within the plan requirements. Data may be removed from the variability calculation & for cause after agency approval.
- For Steps 3 and 4, if the data shows an unacceptable range and variability (the average plus 3 standard deviations is equal to or greater than 81 ppm H_2S), the source will drop back to the previous step's monitoring schedule.
- If at anytime, one detector tube sample value is equal to or greater than 81 ppm H_2S , then begin sampling as specified in Step 6. Note: Standard deviation cannot be calculated for a dataset containing one point.

Monitoring Schedule for Approved AMPs

For gas streams which must meet product specifications for sulfur content, one time only detection tube sampling along with a certification that the gas stream is subject to product or pipeline specifications is sufficient for the AMP. If the gas stream composition changes (i.e., new gas sources are added), or if the gas stream will no longer be required to meet product or pipeline specifications, then the gas stream must be resubmitted for approval under the AMP.

The following are examples of streams needing one time only monitoring:

- Certified commercial grade natural gas;
- Certified commercial grade LPG;
- Certified commercial grade hydrogen;
- Gasoline vapors from a loading rack that only loads gasoline meeting a product specification for sulfur content

For other gas streams, the H₂S content of each refinery fuel gas stream/system with an approved AMP shall be monitored per the following schedule:

Step 1:

The refinery will monitor the selected process parameter for each stream/system, according to the established process parameter monitoring or review schedule approved by the agency in the AMP, and at times when conducting H₂S detector tube sampling.

Step 2:

The refinery will conduct random detector tube sampling twice per week for each stream/system for a period of six months (52 samples). For fuel gas streams infrequently generated and combusted in affected fuel gas combustion devices (i.e., frequent than bi-weekly), detector tube samples shall be taken the fuel gas stream is generated and combusted. A total of at least 24 samples shall be collected for infrequently generated gas streams. Monitor and record the selected process parameter in accordance with the established schedule, and at times when conducting H₂S testing. Move to Step 3 if the calculated range and variability of the data meets the established acceptance criteria. Submit test data (raw measurements plus calculated average and variability) to the agency quarterly.

Step 3:

The refinery will conduct random H₂S sampling once per quarter for a period of six quarters (6 samples) with a minimum of 1 month between samples. A minimum of 9 samples are required for infrequently generated and combusted fuel gas streams before proceeding to Step 4. Continue to monitor and record the selected process parameter in accordance with the established schedule, and at times when conducting H₂S testing. Move to Step 4 if the calculated range and variability of the data meets the established acceptance criteria. Submit test data (raw measurements plus calculated average and variability) to the agency quarterly.

step 4:

The refinery will conduct random H₂S sampling twice per year for a period of two years (4 samples); sample randomly in the 1st and 3rd quarters with a minimum of 3 months between samples. Continue to monitor and record the selected process parameter in accordance with the established schedule, and at times when conducting H₂S testing. Move to Step 5 if the calculated range and variability of the data meets the established criteria. Submit test data (raw measurements plus calculated average and variability) to the agency semiannually.

Step 5:

D.J. 11

The refiner will continue to conduct testing on semi-annual basis. Testing is to occur randomly once every semiannual period with a minimum of 3 months between samples. Continue to monitor and record the selected process parameter in accordance with the established schedule, and at times when conducting H₂S testing. If any one sample is equal to or greater than 81 ppm H₂S, then proceed to the sampling specified in Step 7. Note: Standard deviation cannot be calculated for a dataset containing one point.

Step 6:

If, at any time, the selected process parameter data indicates a potential change in H₂S concentration, or a single detector tube sample value is equal to or greater than 81 ppm H₂S, then the fuel gas stream shall be sampled with detector tubes on a daily basis for 7 days (or for infrequently generated gas streams • 7 samples during the same period of an indicated change in H₂S concentration, or as otherwise approved by agency). If the average detector tube result ± 3 standard deviations for those seven samples is less than 81 ppm H₂S, the date and value of change in the selected process parameter indicator and the sample results shall be included in the next quarterly report, and the refiner shall resume monitoring in accordance with the schedule of the current step. If the average plus 3 standard deviations for those seven samples is equal to or greater than 81 ppm H₂S, sampling shall follow the requirements of Step 7.

Step 7:

If sample detector tube data indicates a potential for the emission limit to be exceeded (the average ± 3 standard deviations is equal to or greater than 81 ppm H₂S), as determined in the Data Range and Variability Calculation and Acceptance Criteria or in Step 6, the refiner shall notify the agency of those results before the end of the next business day following the last sample day. The fuel gas stream shall subsequently be tested daily for a two week period (or 14 samples during the same event or as otherwise approved by agency for infrequently generated gas streams). After the two week period is complete, sampling will continue once per week, until the agency approves a revised sampling schedule or makes a determination to withdraw approval of the gas stream/system from the AMP. Note: At any time, a detector tube value in excess of the 162 ppm limit is evidence that the emission standard has been exceeded.

General Provisions of Approved AMPs

Upon agency request, the refiner shall conduct a test audit for any gas stream with an approved AMP. The audit shall consist of daily detector tube samples collected over a one week period (7 samples). For fuel gas streams infrequently generated and combusted in affected fuel gas combustion devices, an audit shall consist of 3 consecutive sampling events. (e.g., Rail loading may occur once per month, an audit would consist of 3 consecutive loading events.) The United States Environmental Protection Agency, with due notice, reserves the right to withdraw approval of the AMP for any gas stream/system.

The source shall keep records of the H₂S detector tube test data and the representative process parameter data and fuel source for at least two years.

If a new fuel gas stream is introduced into a fuel gas stream with an approved AMP, the refiner shall again apply for an AMP and repeat Steps I - 5.

Example:

An AMP Application for a Hydrogen Plant PSA Off-Gas Stream Combusted Exclusively in the Hydrogen Plant Process Heater:

Process Description

Hydrogen production for the refinery by the steam methane reforming process. CO is the primary impurity in the hydrogen produced; small amounts of CO and methane are also present. Unpurified hydrogen is passed over molecular sieve absorbent beds to remove these impurities. The off-gas from regeneration of the absorbent beds is called PSA off-gas. It is sent to the hydrogen plant heater to recover heat and control CO emissions.

Piping Diagrams

Piping diagrams should be supplied to show monitoring location and to demonstrate that there is no potential for cross over or entry points for sour gas.

Basis for PSA Off-Gas Low H₂S Content

Since PSA off-gas is a byproduct of hydrogen purification, any H₂S in the PSA purge gas must come from the hydrogen unit feed. Levels of H₂S in the PSA gas are negligible because H₂S must be controlled to prevent deactivation of the unit's catalyst.

H₂S is a permanent catalyst poison. The hydrogen unit has 2 scrubbers to remove H₂S from the feed gas to protect the unit's catalyst from H₂S poisoning. The scrubbers are operated in series. The lead scrubber must exhibit at least a 70% reduction in H₂S content. If not, the scrubber is taken offline and the absorbent is replaced. After the absorbent is replaced, the scrubber is placed online as the second scrubber in series. This maximizes the amount of H₂S removal and assures maximum scrubbing potential when one scrubber is offline for absorbent replacement.

Process Parameter Monitoring and Suggested Process Parameter Limit

Operation of the scrubbers is checked on a monthly basis with detector tubes. The feed gas H₂S content is measured at the inlet and outlet of the lead scrubber. If natural gas is used as hydrogen plant feed; both readings are below the ppm detection limit. If refinery fuel gas is the feed gas, 30 ppm to 40 ppm H₂S is normally detected at the inlet. A lead scrubber outlet reading of 10-12 ppm would trigger absorbent replacement. The suggested process parameter limit is a 20 ppm H₂S at the lead H₂S absorber outlet. Absorber outlet H₂S measurements will be taken in conjunction with the PSA gas measurements during Steps 2 and 3.

APPENDIXE

Use of SO₂ Reducing Catalyst Additives to Reduce SO₂

This program to reduce SO₂ emissions at each relevant FCCU shall consist of the following steps: baseline data collection and emission model development; a trial period to evaluate the effectiveness of alternative SO₂ reducing catalyst additives; an optimization period to determine optimized addition rates of the selected SO₂ reducing catalyst additive; and a demonstration period to establish appropriate SO₂ concentration based emission limits for the FCCD. On or before the dates specified in Section 7 below for the relevant FCCD, Valero shall commence the activities identified in this appendix.

1. Definitions

- a. "Baseline Total Catalyst Addition Rate" shall mean the daily average Total Catalyst, in pounds per day, added to an FCCD during the baseline period of an SO₂ catalyst additive program.
- b. "Hydrotreater Outage" shall mean the period of time during which the operation of an FCCD is affected as a result of hydrotreater catalyst change-out operations or shutdowns required by ASME pressure vessel requirements or state boiler codes, or as a result of Malfunction, that prevents the hydrotreater from effectively producing the quantity and quality of feed necessary to achieve established FCCD emission performance.
- c. "Pollutant Reducing Catalyst Additive" shall mean either a NO_x Reducing Catalyst Additive or a SO₂ Reducing Catalyst Additive.
- d. "SO₂ Reducing Catalyst Additive" shall mean a catalyst additive that is introduced to an FCCD to reduce SO₂ emissions by reduction and adsorption.
- e. "Total Catalyst" shall mean all forms of catalyst added to the FCCD, including but not limited to base catalyst, equilibrium catalyst, and pollutant reducing catalyst.

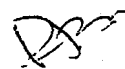

f. "Total Catalyst Addition Rate" shall mean the Total Catalyst added to an FCCD in pounds per day.

g. "Weight % Pollutant Reducing Catalyst Additive Rate" shall mean:

$$\frac{\text{Amount of Pollutant Reducing Catalyst Additive in Pounds per Day}}{\text{Baseline Total Catalyst Addition Rate}} \times 100\%$$

2. **Collection of SO₂ Baseline Data.**

a. By no later than the dates specified in Section 7 below for each relevant FCCU, Valero shall collect and submit to EPA the baseline data specified below. The baseline data shall include at a minimum the following information for the FCCU, on a daily average basis, for the baseline period:

- a. Regenerator flue gas temperature;
- b. FCCD coke burn rate in pounds per hour;
- c. FCCD feed rate in barrels per day;
- d. FCCD feed API gravity;
- e. FCCD feed sulfur in weight %;
- f. Estimated percentage, and where available, actual percentage of each type of FCCD feed component (*i.e.* atmospheric gas oil, vacuum gas oil, etc.)
- g. Estimated percentage, and where available, actual percentage by volume of the FCCU feed that is hydrotreated;
- h. CO boiler combustion temperature, if applicable;
- i. CO boiler firing rate and fuel type, if applicable;
- j. Total catalyst addition rate and catalyst circulation rates;
- k. FCCD conversion rate;
- l. NO_x and SO₂ Reducing Catalyst Additive and addition rates, conventional combustion promoter addition rates, and/or Low NO_x Combustion Promoter addition rates in pounds per day;
- m. Hourly and daily SO₂, NO_x, CO, and O₂ concentrations (For Benicia, only total sulfur concentrations shall be provided per the monitoring program described in Section VI of this Decree); and
- n. Any other parameters that Valero identifies as important before the end of the demonstration period.

Upon request by EPA, Valero will submit any additional reasonably available data that EPA

determines it needs.

- b. By no later than the dates specified in Section 7 below for each relevant FCCD, Valero shall submit to EPA a report describing a model to predict the S02 concentration and mass emission rate for each FCCU ("the Baseline Report").

2. SO₂ Reducing Catalyst Additives - Short Term Trials.

- a. By no later than the dates specified in Section 7 below, for each relevant FCCU Valero shall submit to EPA, for its approval, a proposal and a protocol for conducting trials to evaluate at least two commercially available S02 reducing catalyst additives during the S02 catalyst additive trial of the FCCD ("the Additive Proposal Report").
- b. Valero will propose use of at least two brands of S02 Reducing Catalyst Additives that are likely to perform the best in each FCCD. EPA will base its approval or disapproval on its assessment of the performance of the proposed brands of additives in other FCCDs, the similarity of those FCCUs to Valero's FCCDs, as well as any other relevant factors, with the objective of conducting trials of the brands of S02 Reducing Catalyst Additives likely to have the best performance in reducing S02 emissions. In the event that Valero submits less than two approvable brands of additives, EPA will identify other approved additives brands to Valero.
- c. Valero shall evaluate at least two additives during the trial. Valero shall submit a report to EPA that describes the performance of each S02 catalyst additive evaluated for the FCCD (the "Trial Report and Optimization Protocol"). In the report, Valero will propose

to use the best performing additive as measured by the percentage of S02 reduced and the concentration to which S02 emissions are reduced in the trials, taking into account all relevant factors. EPA will either approve the proposed additive or approve another additive evaluated by Valero during the trial of the FCCU (the "EPA-approved S02 Reducing Catalyst Additive") for use in the optimization study.

3. SO₂ Reducing Catalyst Additives - Optimization Study.

- a. The purpose of the optimization study is to determine the optimized addition rate of the EPA-approved S02 Reducing Catalyst Additive according to the procedures described below. Valero shall commence implementation and complete the Optimization Study by no later than the dates specified in Section 7 below for the relevant FCCU.
- b. By no later than the dates specified in Section 7 below for each relevant FCCU, Valero shall submit for EPA approval, a proposed protocol (the "Trial Report and Optimization Protocol") consistent with the requirements of this appendix for an optimization study to establish the optimized S02 reducing catalyst additive addition rates. The protocol will include methods to calculate effectiveness, methods of baseloading, and amount of additive added at each increment.
- c. Overview. The Optimized S02 Reducing Catalyst Additive Addition Rate will be determined by evaluating S02 emissions reductions at three different addition rates.
- d. The Increments. The three addition rates or "increments" will be:

5.0 Weight % S02 Reducing Catalyst Additive;
7.5 Weight % S02 Reducing Catalyst Additive; and
10.0 Weight % S02 Reducing Catalyst Additive.

e. **The Procedure.** Valero will successively add 802 Reducing Catalyst Additive at each increment set forth above. Once a steady state has been achieved at each increment, Valero will evaluate the performance of the 802 Reducing Catalyst Additive in terms of 802 emissions reductions. The final Optimized 80₂ Reducing Catalyst Additive Addition Rate will occur at the addition rate, in pounds per day, where either:

- (1) the FCCD meets 25 ppmvd 80₂ (corrected to 0% O₂) on a 365-day rolling average and 50 ppmvd 80₂ (corrected to 0% O₂) on a 7-day rolling average, in which case Valero will agree to accept limits of 25 ppmvd 80₂ (corrected to 0% O₂) on a 365-day rolling average and 50 ppmvd 80₂ (corrected to 0% O₂) on a 7-day rolling average at the conclusion of the Demonstration Period;
- (2) the addition of 802 adsorbing catalyst additive limits the FCCD feedstock processing rate or conversion capability in a manner that cannot be reasonably compensated for by the adjustment of other parameters, the maximum addition rate will be reduced to a level at which the additive no longer interferes with the FCCD processing or conversion rate; provided, however, that in no case, will the maximum addition rate be less than 5.0 weight %; or
- (3) the Incremental 80₂ Pick-up Factor is less than 2.0, where the Incremental 80₂ Pick-up Factor is defined as:

$$\frac{PR_i - PR_{i-1}}{CAR_i - CAR_{i-1}}$$

where:

= Pollutant (80₂) reduction rate at increment i in pounds per day from the baseline model

= Pollutant (80₂) reduction rate at the increment prior to increment i in pounds per day from the baseline model

= Total Catalyst Additive Rate at increment i in pounds per day

CAR_{i-1} = Total Catalyst Additive Rate at the increment prior to increment i in pounds per day

If the conditions of either (1), (2), or (3) above are not met at any addition rate less than 10.0 weight % 80₂ Reducing Catalyst Additive, then the Optimized Addition Rate will be 10.0

weight % S02 Reducing Catalyst Additive, in pounds per day. In no case will the Optimized Addition Rate will be less than 5.0 weight % S02 Reducing Catalyst Additive. The Optimized Addition Rate will not be calculated by interpolation between the increments; it will occur at one of the increments.

If an additive limits the processing rate or the conversion capability in a manner that cannot be reasonably compensated for by adjustment of other parameters, the additive level will be reduced to a level at which the additive no longer causes such limits or effects.

- f. By no later than the dates specified in Section 7 below for each relevant FCCU, Valero shall submit to EPA a written report (the "Optimization Report") identifying the results of the S02 Reducing Catalyst Additive Optimization Study for each relevant FCCU. The Optimization Report shall also include Valero's proposal, for EPA approval, for the optimized addition rate of the EPA-approved S02 Reducing Catalyst Additive to be used for the demonstration period. If Valero can demonstrate to EPA's satisfaction that the addition of the selected catalyst additive at the minimum addition rate results in no measurable reduction in S02 emissions then Valero may submit a request for EPA approval to discontinue addition of SOx reducing additives and to complete the Demonstration Period without the use of any SOx reducing additive.

4. S02 Reducing Catalyst Additives - Demonstration.

- a. By no later than the dates specified in Section 7 below for each relevant FCCU, Valero shall commence and complete a demonstration of the EPA-approved S02 Reducing Catalyst Additive at the approved optimized addition rate. During the demonstration, Valero shall both physically add S02 Reducing Catalyst Additive and

operate the FCeU, CO boiler (where applicable) and FCCU feed hydrotreater (where applicable) in a manner that minimizes SO₂ emissions, to the extent practicable without interfering with conversion, or processing rates, provided such cannot be reasonably compensated for by adjustment of other operating parameters.

- b. By no later than the dates specified in Section 7 below for each relevant FCeU, Valero shall submit to EPA a report of the results of the Demonstration Period ("the Demonstration Report"). The Demonstration Report shall include all pertinent data gathered during the Demonstration Period for the categories of information specified in paragraph 2(a) of this Appendix.
- c. At any time prior to the deadline for submission of the Demonstration Report, Valero may notify EPA that it agrees to comply with SO₂ emission limits of 25 ppmvd @ 0% O₂ on a 365-day rolling average basis and 50 ppmvd on a 7-day rolling average basis each at 0% O₂ for a particular FCCU. If Valero makes such a notification, the remaining requirements of this appendix for that particular FCCU shall no longer apply and the limits shall become immediately effective.

5. Establishing SO₂ Emissions Limits.

- a. Except where Valero has notified EPA of its intent to comply with SO₂ emission limits of 25 ppmvd on a 365-day rolling average basis and 50 ppmvd on a 7-day rolling average basis, at 0% oxygen, Valero will propose, in each Demonstration Report, final 7-day rolling average and 365-day rolling average concentration-based (ppmvd) SO₂ emission limits, at 0% oxygen, for each relevant FCCU. Valero will propose a 7-day rolling average concentration limit that will be numerically twice the concentration of the 365-day rolling average concentration limit. Valero

may propose alternative emissions limits to be applicable during Hydrotreater Outages, startup of the FCCU, shutdown of the FCCU, or other alternative operating scenarios. Valero will comply with the emission limits it proposes for each FCCU beginning immediately upon submission of the applicable report for that FCCU. Valero will continue to comply with these limits unless and until Valero is required to comply with the emissions limits set by EPA pursuant to the paragraphs below. Upon request by EPA, Valero will submit any additional, reasonably available data that EPA determines it needs to evaluate the demonstration.

- i. EPA will use the data collected about each FCCU during the baseline period, the optimization period, and the demonstration period, as well as all other available and relevant information, to establish limits for 802 emissions for each relevant FCCU. EPA will establish a 365-day rolling average concentration-based (ppmvd) 80₂ emission limits at 0% oxygen. EPA will determine the limits based on: (a) the level of performance during the baseline, optimization, and demonstration periods; (b) a reasonable certainty of compliance; and (c) any other available and relevant information. EPA will also establish a 7-day rolling average concentration limit that will be numerically twice the concentration of the 365-day rolling average concentration limit.
11. EPA will notify Valero of its determination of the concentration-based 802 emissions limit and averaging times for each FCCU, including how and whether emissions during Hydrotreater Outages are included in the 365-day rolling average. EPA may establish alternative emissions limits to be applicable during Hydrotreater Outages, startup of the FCCU, shutdown of the FCCU, or other alternative

operating scenarios. If EPA agrees with Valero's proposed limits, Valero will continue to comply with these limits. If EPA proposes different limits that Valero does not dispute within thirty (30) days of receiving notification from EPA, Valero will comply with the EPA-established limits by no later than thirty (30) days after notice. If Valero disputes the EPA-established limits, Valero will invoke the dispute resolution provisions of this Decree by no later than thirty (30) days after EPA's notice of the limits. During the period of dispute resolution, Valero will continue to add 802 Reducing Catalyst Additives at the optimized rates and comply with any approved Hydrotreater Outage plan.

111. 802 emissions during periods of startup, shutdown, or Malfunction of an FeCD controlled by catalyst additives, or during periods of Malfunction of a Pollutant Reducing Catalyst Additive system will not be used in determining compliance with the short-term 802 emission limits established pursuant to this appendix, provided that during such periods Valero implements good air pollution control practices to minimize SO₂ emissions.

6. Monitoring Requirements for Benicia FCCU

1. Special monitoring provisions are required for the 80₂ reducing catalyst trial on the Benicia FeCD because this unit utilizes a combined CO Boiler for combustion of flue gas from the Refinery's FCCD and Fluid Coker. Requirements for submittal of a site specific monitoring plan for the Benicia FCCD catalyst additive trial with EPA approval are specified in Paragraph 93 of the Decree. Baseline data collection for the Benicia FCCD will begin by March 31, 2006 or 180 days after EPA's



approval of the site specific monitoring plan, whichever is later.

7. Catalyst Additive Schedule Summary

The schedule for the SO₂ reducing catalyst additive protocol at the five FCCUs using SO₂ reducing catalyst additive is as follows:

	<u>McKee</u>	<u>Krotz Springs</u>	<u>Benicia</u>	<u>Denver</u>	<u>Corpus Christi East</u>	<u>Wilmington</u>
Start to collect baseline data	6-30-06 (Note 2)	12-31-06 (Note 3)	3-31-06	12-31-05	12-31-05	12-31-05
Submit Additive Proposal Report	12-31-06	6-30-07	9-30-06	6-30-06	6-30-06	6-30-06
Complete baseline data collection	6-30-07	12-31-07	3-31-07	12-31-06 (Note 1)	12-31-06 (Note 1)	12-31-06 (Note 1)
Submit Baseline Report and start Trials	9-30-07	3-31-08	6-30-07	3-31-07	3-31-07	3-31-07
Complete Trials	3-31-08	9-30-08	12-31-07	9-30-07	9-30-07	9-30-07
Submit Trial Report and Optimization Protocol	5-31-08	11-30-08	2-29-08	11-30-07	11-30-07	11-30-07
Begin Optimization	8-31-08	2-28-09	5-31-08	2-29-08	2-29-08	2-29-08
Complete Optimization	5-31-09	11-30-09	2-28-09	11-30-08	11-30-08	11-30-08
Submit Optimization Report	8-31-09	2-28-10	4-30-09	2-28-09	2-28-09	2-28-09
Begin Demonstration Period	10-31-09	4-30-10	6-30-09	4-30-09	4-30-09	4-30-09
Complete Demonstration Period	4-30-11	10-31-12	3-31-10	2-28-11	2-28-11	2-28-11
Submit Demonstration Report	6-30-11	12-31-12	5-31-10	4-30-11	4-30-11	4-30-11

If EPA has not approved any of the items requiring its approval under this protocol in a timely fashion, then subsequent deadlines may be modified as agreed to by the parties.

Notes:

1. Baseline data will be collected for all three FCCDs, addressed in Paragraphs 69-72 of the Decree, but the catalyst protocol will only be completed for the two FCCDs that are not chosen for installation of an FCCU scrubber.

RJ

2. The protocol start date for the McKee FCCD is based on a scheduled DeS system upgrade necessary to collect and process data. In addition, the protocol start date is after the start up of a new gasoline desulfurization unit which will result in a varied crude slate and a heavier FCCD feedstock.

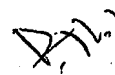

APPENDIX F

LOGIC DIAGRAM FOR PARAGRAPHS 250-253

ALL ACID GAS FLARING/TAIL GAS INCIDENTS

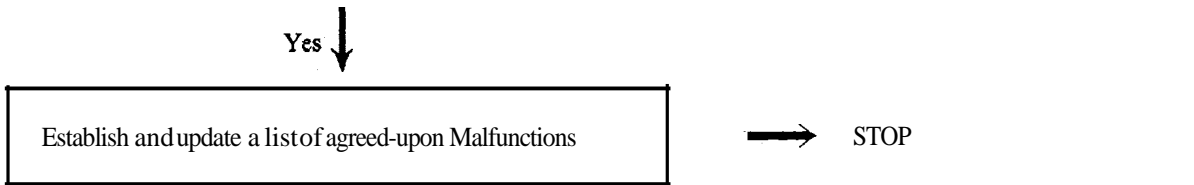
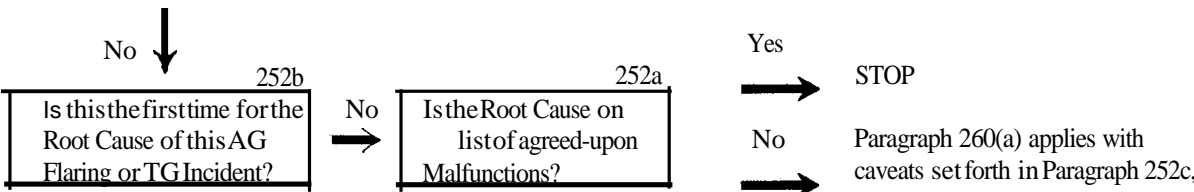
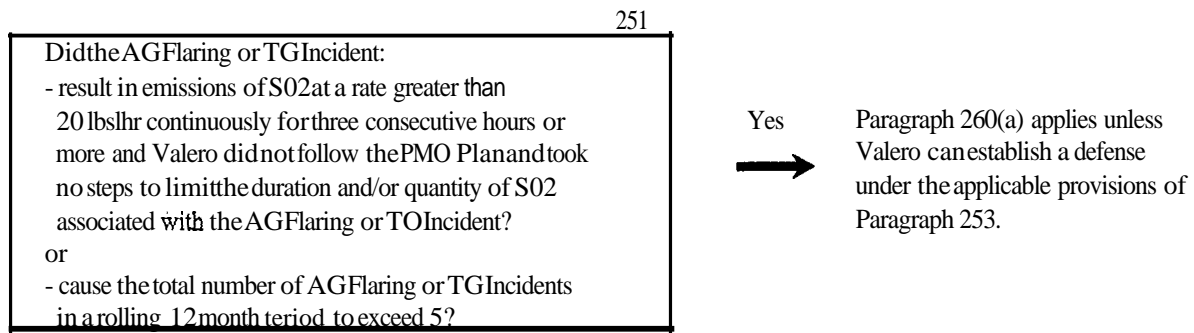
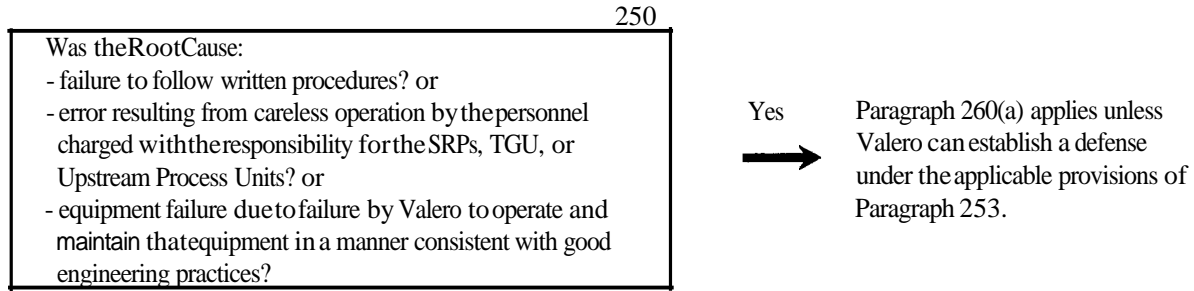

DM

APPENDIXG
End-or-Line Benzene NESHAP Sampling Plans

Handwritten mark

END-OF-LINE BENZENE WASTE
SAMPLING PLAN

Texas City Refinery
Valero Refining - Texas, L.P.
1301 Loop 197 South
Texas City, TX 77590

PREPARED FOR
USEPA

December 22, 2004



TABLE OF CONTENTS

1.0 BACKGROUND AND PURPOSE OF THIS DOCUMENT	1
2.0 WASTE /WASTEWATER MANAGEMENT UNITS	1
3.0 END-OF-LINE BENZENE WASTE SAMPLING LOCATIONS	4
4.0 METHODS OF FLOW DETERMINATION	7
5.0 SAMPLING SCHEDULE	8
6.0 SAMPLING PROCEDURES AND ANALYTICAL TESTING METHODS	9
7.0 CALCULATION METHODS	10
7.1 FLOW-WEIGHTED QUARTERLY BENZENE CONCENTRATION	10
7.2 QUARTERLY AND ANNUAL BENZENE PROJECTIONS	11
7.3 OUTLIER DATA	12
8.0 REPORTING REQUIREMENTS	12

D&W

TABLES

Table 1	Initial End-of-Line Sample Locations
Table 2	Final End-of-Line Sample Locations
Table 3	Methods for Flow Determination for Initial Sample Locations
Table 4	Methods for Flow Determination for Final Sample Locations

APPENDICES

Appendix A	End-of-Line Sampling Locations and Block Flow Diagrams
Appendix B	Example Calculations



END-OF-LINE BENZENE WASTE SAMPLING PLAN

Valero Texas City Refinery
Texas City, Texas

1.0 BACKGROUND AND PURPOSE OF THIS DOCUMENT

This End-of-Line Benzene Waste Sampling Plan (the plan) is a tool to help validate the benzene content of waste streams that are managed at the Texas City Refinery. This protocol will also provide an early-warning for potential increases in the amount of benzene in refinery waste streams. Waste samples will be collected and measured at common, co-mingled locations, downstream of refinery process units (end-of-line) for the purpose of providing a broad view of upstream waste management practices.

The purpose of this plan is to present, for USEPA's approval, end-of-line sampling locations and methods of flow determination that will be used to calculate quarterly and annual projections of benzene quantity in uncontrolled aqueous waste streams for the refinery. The refinery is presently subject to the emission control, recordkeeping and reporting requirements of the 6 BQ compliance option under 40 CFR 61, Subpart FF. Upon USEPA's approval, this plan will be used by facility personnel to implement an end-of-line benzene determination program.

The diagrams provided in Appendix A provide an overview of the waste /wastewater management systems at the Valero Texas City Refinery.

2.0 WASTE / WASTEWATER MANAGEMENT UNITS

The Texas City refinery operates a process wastewater collection system, a segregated stormwater collection system, a contaminated stormwater system, and a slop oil collection system. Appendix A contains schematics showing the process wastewater, contaminated stormwater, and slop oil systems. The segregated stormwater system is not depicted because this water is exempt from Subpart FF and

is discharged directly through facility outfalls (in accordance with applicable federal and state regulations).

Process Wastewater System - Process wastewaters collected throughout the facility are routed through a common process water lift station and then to an API Separator. The separated oil is routed to a slop oil collection tank (T-320) and then returned to the refining process. Water phase from the API Separator is routed through an equalization tank (T-092), through a dissolved air floatation (DAF) unit and into the facility's biological treatment and clarifier systems prior to ultimate discharge from the facility. Oil is occasionally skimmed from the top of Tank T-092 (approximately weekly) and routed to the slop oil system.

Wet sludge recovered from the API Separator and DAF is stored in Tanks T-070 and T-071 prior to being de-watered in belt presses. Water draws from Tanks T-070/T-071 and the water removed from sludge at the filter press are returned to the API Separator. The dewatered sludge from the filter press is sent off-site as a solid waste.

Contaminated Stormwater System - Contaminated stormwater collected at the facility is routed through a lift station, through Tank T-078, through the equalization tank (T-092), through the DAF, and into the biological treatment/clarifier systems prior to being ultimately discharged. Contaminated stormwater can also be diverted through the API Separator prior to entering the equalization tank if it is determined to be unsuitable for direct routing to the equalization tank. The stormwater can also be diverted directly to the DAF, if its quality is determined to be suitable for bypassing the equalization tank.

Slop Oil System - Process generated slop oil is routed directly to Tank T-095, or indirectly to T-095, via Tank T-320. T-095 slop oil is returned to the refining process as described above. Water accumulated in T-095 is routinely routed to a sourwater stripper through a closed system. Other slop oil is routed to Tank T-321 where oil/water phase separation occurs. Water from Tank T-321 is routed to the API Separator (or the Process Lift Station) where it joins with other process water streams and is then routed through the wastewater treatment unit. Oil from Tank T-321 is routed to

Slop Oil Tank T-095 and then returned to the refining process.

Emission Controls - Diagrams in Appendix A identify two end-of-line sampling strategies based on two control configurations. Although the Texas City Refinery is currently in compliance with the 6 BQ compliance option under NESHAP FF, the refinery is in the process of controlling numerous process unit sewers, the main process lift station and the API separator to provide additional assurance of ongoing compliance.

Figure I in Appendix A shows the refinery's current configuration and the sources that are controlled as required by NESHAP FF. Controls are in place on all slop oil tanks, spent caustic tanks and the wastewater equalization tank. Initially samples will be taken from seven routine, end-of-line sampling locations and one additional sample "location" to address miscellaneous maintenance or process wastes that are not routed through the wastewater treatment system (such as uncontrolled wastes associated with turnarounds, spent caustic, etc). Miscellaneous wastes will be included in the end-of-line calculation when generated (as discussed in Section 3.0). As long as miscellaneous wastes are controlled from point of generation and are managed in systems that meet the control standards under NESHAP FF (including vacuum trucks meeting the container requirements), they will not be included in the end-of-line demonstration. DAF sludge will be sampled for three quarterly events. If the annualized benzene levels in the DAF sludge are significant, the DAF sludge will continue to be collected on a quarterly basis. If the benzene level in the DAF sludge is not significant, it will no longer be included in the end-of-line demonstration.

Figure 2 in Appendix A shows the final control configuration. Once these additional sewer controls are in place, there will be very few NESHAP wastes that will not be managed in the controlled system. This system will be closed until the phase separated water is discharged from the equalization tank to the DAF unit. Final end-of-line samples will be taken from six routine locations and one additional "location" to address miscellaneous uncontrolled waste streams.

Listed below is the control status of each process unit after the final sewer control scheme.

Units with Controlled Sewers

Topper Units Nos. 1 and 2	Gasoline Desulfurization Unit	ROSE Unit
Crude Unit No.3	PENEXUnit	MTBEUnit
FCCU	GasCon	Diesel Hydrotreater
Refonner#2	Saturated GasUnit	
Delayed Coker Unit	Gas OilHydrotreater (GOHT)	

Units with Uncontrolled Sewers

Middle Distillates Hydrotreater	South Plant Amine	GOHT SRUITGU's
HF Alkylation	South Plant SRUITGU	GOHT Sour Water Stripper
Resid Vacuum Distillation Unit	South Plant Sour Water Stripper	Utilities
Propylene/Propane Unit	GOHT Amine	Laboratory

3.0 END-OF-LINE BENZENE WASTE SAMPLING LOCATIONS

This document describes two end-of-line scenarios. The initial plan is based on the current control scheme in use at the refinery. The final plan will be used when installation of additional sewer controls at the refinery is complete.

The initial plan includes seven quarterly end-of-line benzene sampling locations and one "as generated" sample location. These locations are identified in Figure 1 of Appendix A. Table 1 summarizes general information about these end-of-line sampling locations.

TABLEt

Initial End-of-Line Sampling Locations

Location I.D.	Location Description	Waste Stream Description
EOL1	API Separator Oil Effluent	Oil flow from API Separator
EOL2	Wet Sludge From API Separator	API wet sludge prior to Tanks T-070/071.
EOL3	TK-092 Water Effluent	Total wastewater flow from refinery operations
EOL4	TK-092 Oil Skimmings	Oil skimmed from wastewater equalization tank
EOL5	TK-078 Oil Skimmings	Oil skimmed from stormwater collection tank
EOL6	TK-078 Stormwater Effluent	Contaminated stormwater leaving Tank TK-078
EOL7	Wet Sludge From DAF	DAF wet sludge prior to Tanks T-070/071.
EOL8	Uncontrolled Aqueous Wastes from Maintenance Activities	Maintenance and process related wastes not routed through EOL 1-7. These streams will be included in the end-of-line calculation as generated. Examples might include wastes from tank cleaning or turnaround activities.

The final sampling plan includes six routine sample locations and one as generated sample location. These locations are identified in Figure 2 of Appendix A. Table 2 summarizes general information about these end-of-line sampling locations.

After implementation of the final plan, the individual sewers from uncontrolled process units will be sampled on a quarterly basis for 2 quarters. If the two quarterly benzene levels are less than 0.1 megagrams, based on an annual projection, the sampling frequency will be reduced to annually for two years. If the annualized benzene level remains below 0.1 megagrams, the sewer will no longer be included in the end-of-line demonstration. If, at any time, the annualized benzene contribution from an individual unit is greater than 0.1 megagrams, it will become a routine quarterly sample location under the end-of-line protocol.

TABLE 2

Final End-of-Line Sampling Locations

Location I.D.	Location Description	Waste Stream Description
EOL1	TK-078 Oil Skimmings	Oil skimmed from stormwater collection tank
EOL2	TK-078 Stormwater Effluent	Contaminated stormwater leaving Tank TK.-078
EOL3	TK.-092 Equalization Tank Effluent	Total wastewater flow from refinery operations
EOL4	Wet Sludge From API Separator	API wet sludge prior to Tanks T-070/071.
EOL5	Wet Sludge From DAF	DAF wet sludge prior to Tanks T-070/071.
EOL6	Individual sewers from uncontrolled process units	Wastewater from uncontrolled process unit sewers
EOL7	Uncontrolled Aqueous Wastes from Maintenance Activities	Maintenance and process related wastes not routed through EOL 1-3. These streams will be included in the end-of-line calculation as generated. Examples include wastes from tank cleaning or turnaround activities.

4.0 METHODS OF FLOW DETERMINATION

Table 3 summarizes how flow will be determined for the initial end-of-line sampling strategy. Table 4 summarizes how flow will be determined the final end-of-line sampling strategy.

TABLE 3

Methods of Flow Determination for Initial Sample Locations

Location I.D.	Flow Determination Methodology
EOL 1	Determined by monitoring the operational time of the oil discharge pump to T-320 and multiplying by the pump's curve design capacity at discharge pressure.
EOL2	Determined by tank gauging records for Tanks T-070/T-071 [this will result in double counting the benzene in DAF Sludge, but historic testing suggests this benzene contribution will be negligible],
EOL3	Existing wastewater flow measurement device (positioned at outfall location).
EOL4	Vacuum Truck Transfer Records
EOL5	Vacuum Truck Transfer Records
EOL6	Flow meter on tank effluent line.
EOL7	Determined based on best professional judgment estimates.
EOL8	Determined based on best professional judgment estimates at the time of generation. Actual flow measurement or tank gauging information will be used whenever available.

TABLE 4

Methods of Flow Determination for Final Sample Locations

Location ID.	Flow Determination Methodology
EOL 1	Vacuum Truck Transfer Records
EOL2	Flow meter on tank effluent line.
EOL3	Existing wastewater flow measurement device (positioned at outfall location).
EOL4	Determined by tank gauging records for Tanks T-0701T-071 [this will result in double counting the benzene in DAF Sludge, but historic testing suggests this benzene contribution will be negligible].
EOLS	Determined based on best professional judgment estimates
EOL6	Determined based on best professional judgment estimates
EOL7	Determined based on best professional judgment estimates at the time of generation. Actual flow measurement or tank gauging information will be used whenever available.

Note: In both the initial and final cases, the benzene contribution from contaminated stormwater from TK-078 will be subtracted from the benzene found in the equalization tank effluent when TK-078 water is routed through the API separator or the equalization tank.

5.0 SAMPLING SCHEDULE

As a minimum, end-of-the-line benzene waste sampling will be conducted on a quarterly basis. At least 3 samples will be collected and analyzed from each routine sample location and each uncontrolled maintenance/process waste generated during the quarter. If the maintenance/process wastes are commingled during their management, a sample location will be selected after commingling to afford the least number of samples possible while still accomplishing the end-of-line goal. The refinery may collect more samples as deemed appropriate to better characterize the benzene quantities at the sample locations (e.g., benzene concentration of the sample appears to be out of the typical historical range). Flow-weighted average benzene concentrations will be used for multiple samples if flow is determined to be variable (in accordance with Section 7 of the plan).

6.0 SAMPLING PROCEDURES AND ANALYTICAL TESTING METHODS

The Valero Texas City Refinery will conduct benzene waste sampling using the following sampling procedures, in accordance with 40 CFR §61.355(c)(3):

- All samples provided to the laboratory will be contained in 40 mL VOA sampling vials or equivalent;
- For enclosed pipe sampling, a sampling apparatus capable of delivering a sample at less than 10°C to the sample container will be used;
- For tank or basin sampling, representative samples will be collected by submerging a corked sample collection bottle to the desired level in the tank or basin followed by removal of the cork (the sample will then be immediately transferred to an appropriate VOA container);
- If two phases exist, the water phase sample will be collected in one vial and the oil phase sample will be collected in another vial;
- Oil samples collected from slop oil tanks using the cork and bottle technique discussed above will be collected from at least two different vertical locations to account for possible tank stratification;
- Sample vials will be completely filled and immediately capped to avoid headspace (no air bubbles); and
- Samples will be maintained at a temperature <10°C until delivery to the laboratory.

The Valero Texas City Refinery will submit collected samples to an analytical laboratory for analysis using one of the following USEPA benzene testing methods, in accordance with 40 CFR §61.355(c)(3)(iv):

- 802Q-EPA Publication SW-846;
- 802I-EPA Publication SW-846;
- 824Q-EPA Publication SW-846;
- 826Q-EPA Publication SW-846;

- 602--40 CFR part 136, appendix A; or
- 624-40 CFR part 136, Appendix A.

The refinery will follow chain-of-custody procedures and will maintain these records with analytical results.

7.0 CALCULATION METHODS

7.1 FLOW-WEIGHTED QUARTERLY BENZENE CONCENTRATION

All benzene results collected from sample locations identified in this plan during a quarter will be utilized in the calculations, except as discussed in Section 7.3 (Outlier Data).

If waste flow is constant, the flow-weighted concentration is the average concentration of all samples from a particular sample location. If waste flow is not constant, concentration will be adjusted to reflect flow using the following equation, which is consistent with the test procedures of 40 CFR 61.355(c)(3)(v).

$$\bar{C} = \frac{1}{Q_t} \times \sum_{i=1}^n (Q_i)(C_i)$$

Where:

C = Flow-weighted quarterly average benzene concentration for waste stream (ppmw)

Q_t = Total quarterly waste quantity for waste stream (Mg/calendar quarter)

n = Number of waste samples

Q_i = Quarterly waste quantity for waste stream represented by C_i (Mg/calendar quarter)

C_i = Measured concentration of benzene in waste sample i (ppmw)

Example 1 in Appendix B illustrates the calculation of a flow-weighted quarterly benzene concentration using the above-referenced equation.

7.2 QUARTERLY AND ANNUAL BENZENE PROJECTIONS

The quarterly and annual benzene projections are based on the benzene contained in the water and oil phases of the end-of-line sample locations. The following equation illustrates the total benzene calculation.

$$Q_b = \sum_{i=1}^m \left(Q_i^{water} \times \bar{C}_i^{water} \right) + \sum_{i=1}^n \left(Q_i^{oil} \times \bar{C}_i^{oil} \right)$$

Where:

Q_b = Total quarterly (or annual) benzene quantity (Mg/calendar quarter)

m = Number of waste streams with water phase

Q_i^{water} = Quarterly (or annual) water quantity for waste stream represented by C_i^{water} (Mg/calendar quarter)

\bar{C}_i^{water} = Flow-weighted quarterly average benzene concentration in a water phase of waste stream i (ppmw)

n = Number of waste streams with oil phase

Q_i^{oil} = Quarterly (or annual) oil quantity for water phase waste stream represented by $C_{i oil}$ (Mg/calendar quarter)

\bar{C}_i^{oil} = **Flow-weighted** quarterly average benzene concentration in an oil phase of waste stream i (ppmw)

Example 2 in Appendix B illustrates the calculation of a total quarterly benzene quantity using the above-referenced equation.

Adjustments may be made to the quarterly or annual projections based upon process knowledge. As an example, if an elevated quarterly projection is due to an event that is not expected to recur, the annual projection may be adjusted down to reflect this fact. Any such adjustments will be explained in the quarterly report submitted to EPA.

In both the initial and final cases, the benzene contribution from contaminated stormwater from TK-078 will be subtracted from the benzene found in the equalization tank effluent when TK-078 water is routed through the API separator or the equalization tank.

7.3 OUTLIER DATA

Any benzene results that are suspect will be immediately resampled. If the sample result is in excess of 200 ppmw it will be assumed to be the result of hydrocarbon contamination and the first result will not be utilized in the end-of-line calculation. This is based upon Valero's experience that benzene in refinery wastewater samples is rarely found in excess of 80 ppm. This low solubility is due to the other organics and salts that are also present in solution.

If a result is obtained for an aqueous sample that is suspect, but is less than 200 ppm, Valero will evaluate the sample *QA/QC* information to determine if there is any reason the data should not be utilized in the end-of-line determination. If there is no basis to discount the result it will be handled as follows. If the results of the second sample are less than 10% of the first result, the first result will be determined to be erroneous. Otherwise, the suspect result will be used along with any additional results that are obtained for this stream during the quarter to determine the average quarterly benzene concentration.

If Valero determines that the results from any aqueous or organic sample are outliers based on additional information, evaluation or analysis, the basis for this claim will be explained in the quarterly report submitted to EPA.

8.0 REPORTING REQUIREMENTS

The Valero Texas City Refinery will submit quarterly benzene determination results to the USEPA as required by the consent decree.

APPENDIX A
END-OF-LINE SAMPLING LOCATIONS & BLOCK FLOW DIAGRAM

D.M.

APPENDIXB
EXAMPLE CALCULATIONS

Don

EXAMPLE 1

Refinery A has one end-of-line (EOL) sampling location. During the 3rd quarter of 2001, Refinery A conducted three sampling events at the EOL point. The sampling events were conducted on July 15, at 60-minute intervals. During each sampling collection event, the waste stream at the EOL point had both water and oil phases. Refinery A collected representative water and oil phase samples during each sampling event. These samples from each phase were submitted to a laboratory for benzene analyses. In addition, Refinery A determined water and oil phase flows that occurred at the EOL point during each sampling event. Refinery A also determined total water and oil phase flow at EOL point for the 3rd quarter of 2001. Refinery A summarized all of the above-referenced data in table below.

REFINERY A
EOL SAMPLING DATA FOR 3RD QUARTER OF 2001

Parameter/Unit	July 15, 01 Sample 1	July 15, 01 Sample 2	July 15, 01 Sample 3
Benzene concentration in water phase (ppmw)	20	30	25
Benzene concentration in oil phase (ppmw)	500	350	400
Water flow at EOL point (Mg/calendar Quarter)	19,500	19,100	19,600
Oil flow at EOL point (Mg/calendar Quarter)	22	30	35

The following equation illustrates calculation of flow-weighted quarterly average benzene concentration in a water phase of the waste stream:

$$C_{\text{water}}^{\text{water}} = \left(\frac{1}{19,500 + 19,100 + 19,600} \right) \times (20 \times 19,500 + 30 \times 19,100 + 25 \times 19,600) = 25 \text{ ppmw}$$

The following equation illustrates calculation of flow-weighted quarterly average benzene concentration in an oil phase of the waste stream:

$$\underline{C''} = \left(\frac{1}{22+30+35} \right) X (500x22 + 350x30 + 400X35) = 408 \text{ Ppmw}$$

EXAMPLE 2

Total quarterly benzene quantity for Refinery A (see Example 1 for Refinery A's data) is calculated in the following manner:

$$Q = \frac{(19,400 \times 25) + (29 \times 408)}{10^6} = 0.50 \text{ Mg/calender quarter}$$

Figure 1 - Initial End of Line Sampling Locations

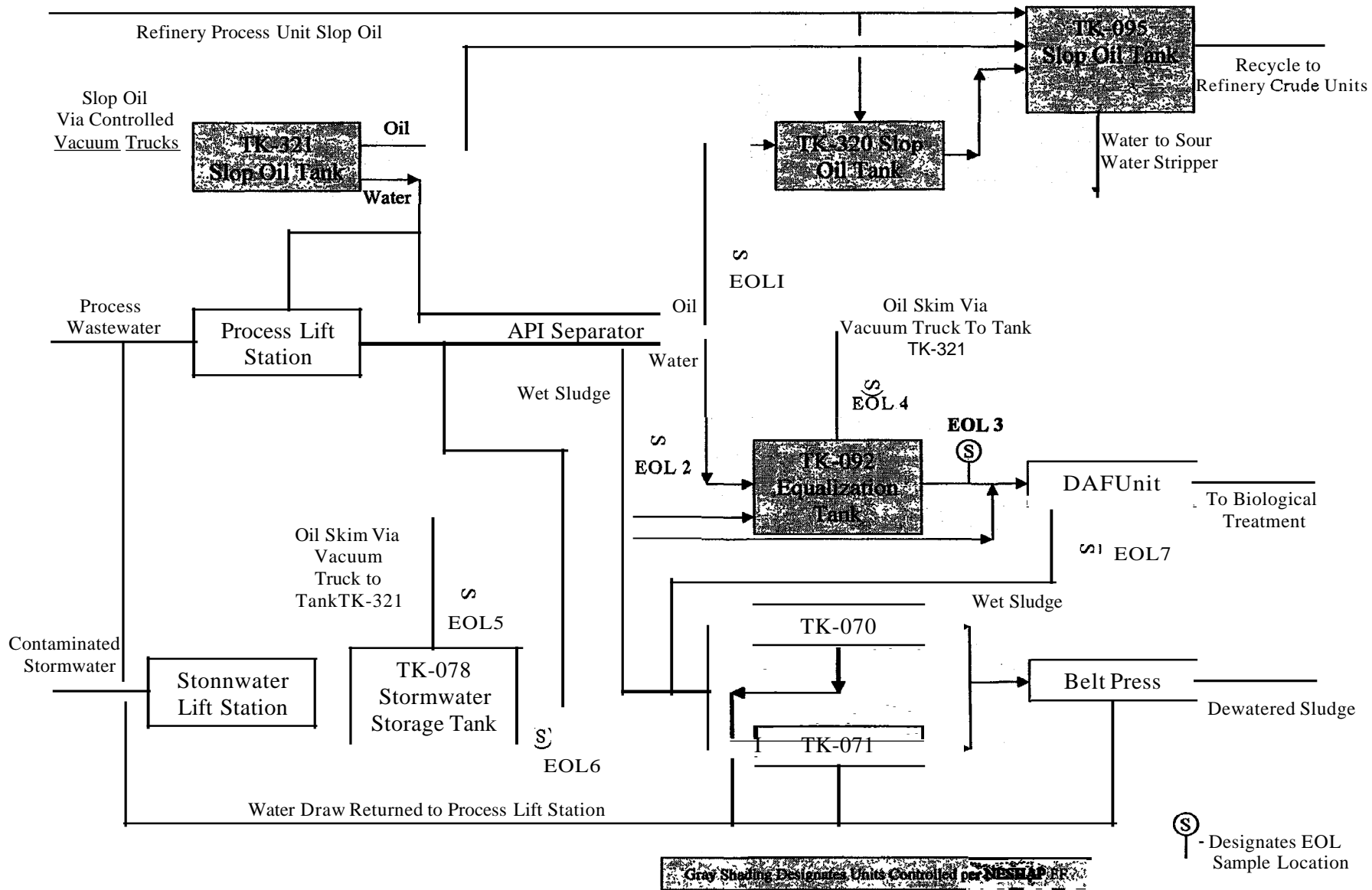
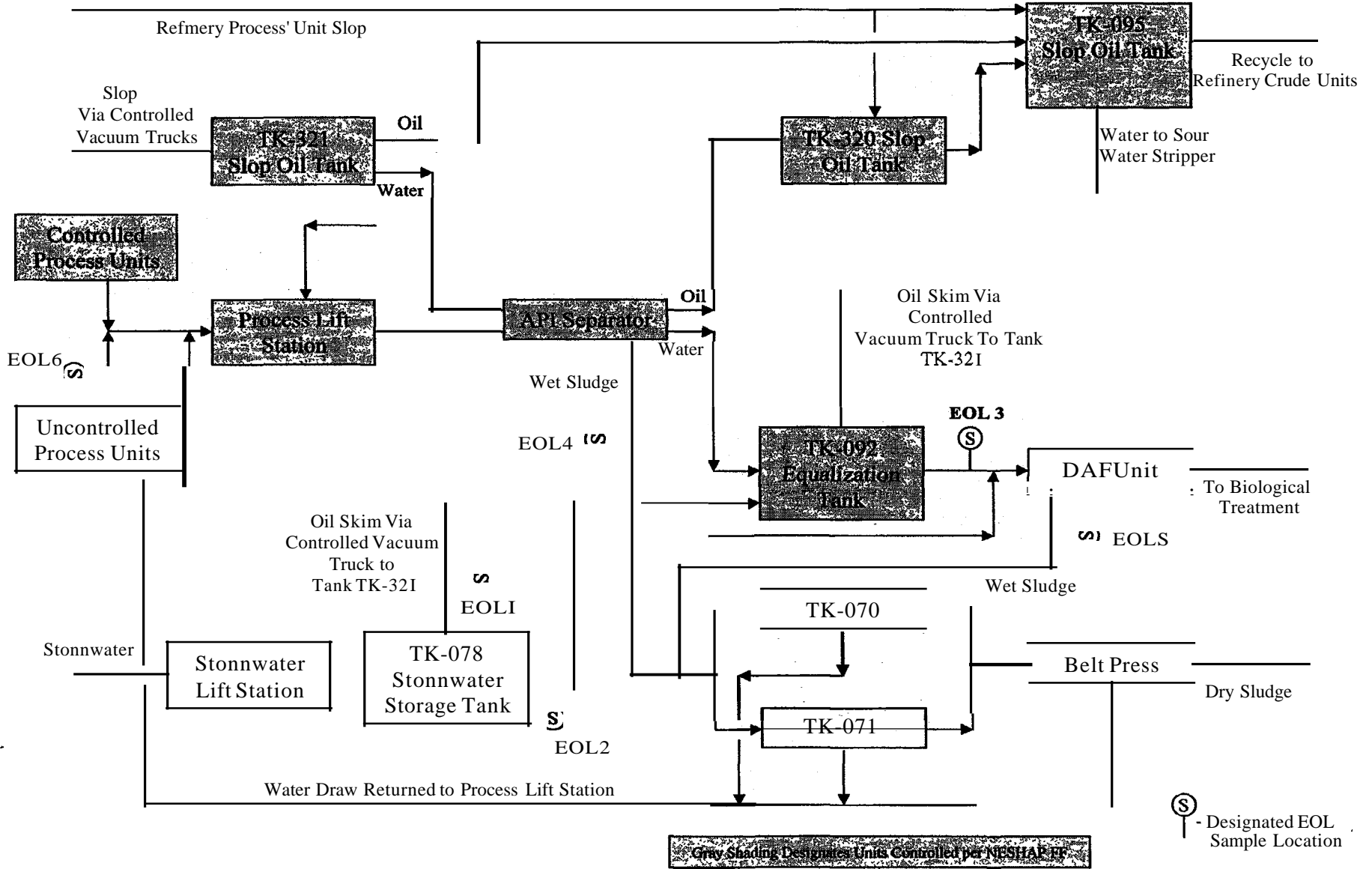

Figure 2 - Final End of Line Sampling Location



**ENO-CF-LINE BENZENE WASTE
SAMPLING PLAN**

**Valero Refining CO • LA
Krotz Springs Refinery
356 Hwy 105 S
Krotz Springs, LA 70750**

**PREPARED FOR
USEPA**

December 23, 2004

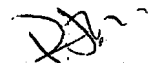

TABLE OF CONTENTS

1.0 BACKGROUND AND PURPOSE OF THIS DOCUMENT	1
2.0 WASTE /WASTEWATER MANAGEMENT UNITS	1
3.0 END-OF-LINE BENZENE WASTE SAMPLING LOCATIONS	3
4.0 METHODS OF FLOW DETERMINATION	4
5.0 SAMPLING SCHEDULE	5
6.0 SAMPLING PROCEDURES AND ANALYTICAL TESTING METHODS	6
7.0 CALCULATION METHODS	7
7.1 FLOW-WEIGHTED QUARTERLY BENZENE CONCENTRATION	7
7.2 QUARTERLY AND ANNUAL BENZENE PROJECTIONS	8
7.3 OUTLIER DATA	9
8.0 REPORTING REQUIREMENTS	9

285

TABLES

Table 1 , End-of-Line Sampling Locations

Table 2 Methods for Flow Determination

APPENDICES

Appendix A End-of-Line Sampling Locations and Block Flow Diagram

Appendix B Example Calculations

ENO.QF-LINE BENZENE WASTE SAMPLING PLAN

Valero Krotz Springs Refinery Krotz Springs, LA

1.0 BACKGROUND AND PURPOSE OF THIS DOCUMENT

The End-of-Line Benzene Waste Sampling Plan (the plan) is a tool to validate the benzene content of waste streams that are managed at the Krotz Springs Refinery. This protocol will also provide an early-warning for potential increases in the amount of benzene in refinery waste streams. Waste samples will be collected and measured at common, co-mingled locations, downstream of refinery process units (end-of-line) for the purpose of providing a broad view of upstream waste management practices.

The purpose of this plan is to present, for USEPA's approval, the end-of-line sampling locations and methods of flow determination that will be used to calculate the quarterly and annual projections of benzene quantity in aqueous waste streams for the refinery. The facility is not subject to the control requirements of Subpart FF because the Refinery's total annual benzene quantity does not exceed 10 Mg/yr. Upon USEPA's approval, this plan will be used by facility personnel to implement an end-of-line benzene determination program.

Figure 1 in Appendix A provides an overview of the waste/wastewater management systems at the Valero Krotz Springs Refinery.

2.0 WASTE / WASTEWATER MANAGEMENT UNITS

The Valero Krotz Springs Refinery's total annual benzene (TAB) quantity is currently less than 10 Mg/yr; therefore the facility is only subject to Benzene Waste Operations NESHAP recordkeeping and reporting requirements (as specified in 40 CFR Part Subpart FF). The Krotz Springs Refinery operates a process wastewater collection system, a stormwater collection system, and a segregated slop oil collection system. Appendix A contains a

schematic depicting the process wastewater and stormwater systems and their interrelationships with each other.

Process Wastewater System- Process wastewaters are collected throughout the facility and are routed through equalization tanks (90TK25-1 and 90TK80-14) and then into a corrugated plate separator (CPS). Oil is separated in these tanks and the CPS, but the majority of oil/water separation occurs in 90TK25-1. The water phase from the CPS is routed through a dissolved air floatation (DAF) unit and into the facility's biological treatment and clarifier systems prior to ultimate discharge from the facility under the NPDES program. Oil from 90TK25-1 is routed back to crude tankage on a monthly basis. The separated oil from the CPS and the other equalization tanks is also routed back to crude oil tankage but on a much less frequent basis (2 to three times per year). The sludge from the CPS is routed to tank 90TK8-60. Spent caustic is used for neutralization in the process units as well as at the wastewater treatment system. All spent caustic produced is used on-site. The minimal amounts of hydrocarbon accumulated in the spent caustic tanks are routed to the wastewater treatment system.

Contaminated Stormwater- The water level in the wastewater treatment plant equalization tanks are maintained to allow for surge capacity for contaminated stormwater, 90TK8-01 is also used to collect contaminated stormwater and process wastewater. Water from 90TK8-01 is routed back to 90TK25-1, and oil is routed to crude oil tankage. Thus, any benzene contained in contaminated stormwater will be represented in the end-of-line samples for routine wastewater.

Slop Oil System- The refinery maintains a segregated slop oil collection system. Slop oil that is determined to contain less than 10% water is routed to tank 90TK3-02 and then it is returned to crude oil tankage. Slop oil that contains 10% or more water is routed to tank 90TK5-01. Any water generated from this tank is routed to a lift station located prior to 90TK25-1. The oil from tank 90TK5-01 is returned to crude oil tankage.

3.0 END-OF-LINE BENZENE WASTE SAMPLING LOCATIONS

Valero has identified eight (8) end-of-line benzene sampling locations at the Krotz Springs Refinery. A diagram depicting these locations is included in Appendix A. Table 1 summarizes general information about these end-of-line sampling locations.

TABLE 1
END-OF-LINE SAMPLING LOCATIONS

Location 1.0.	Location Description	Waste Stream Description
EOL-1	CPS Effluent	Total Wastewater flow from refinery operations
EOL-2	CPS Oil Effluent	Oil Flow from the CPS
EOL-3	CPS Sludge	Sludge from the bottom of the CPS
EOL-4	Oil Skimmings from Wastewater Equalization Tank 90TK25-1	Oil skimmed from wastewater equalization tank. A sample will be collected quarterly from the accumulated oil layer on the tank.
EOL-5	Oil Skimmings from Wastewater Equalization Tank 90TK80-14	Oil skimmed from wastewater equalization tank. A sample will be collected quarterly from the accumulated oil layer on the tank
EOL-6	Oil Skimmings from Tank 90TKS-01	Oil skimmed from wet slop oil tank. A sample will be collected quarterly from the accumulated oil layer on the tank
EOL-7	Oil Skimmings from Wastewater Equalization Tank 90TK8-01	Oil skimmed from storm surge tank. A sample will be collected quarterly from the accumulated oil layer on the tank
EOL-8	Uncontrolled Aqueous Wastes from Maintenance Activities	Maintenance and process related wastes not routed through EOL 1-7. These streams will be included in the end-of-line calculation as generated. Examples might include wastes from tank cleaning or turnaround activities.

The chosen sample points are located after oil/water phase separation and equalization. Sampling in this manner greatly reduces the possibility of organic contamination of aqueous samples. In addition, equalized samples provide a better estimate of the average benzene concentration. When sampling tanks 90TK25-1, 90TK80-14, 90TK5-01, and 90TK8-01, if the accumulated oil layer is greater than 2 feet, efforts will be made to collect a composite

sample of the accumulated oil to account for varying benzene concentrations due to stratification.

4.0 METHODS OF FLOW DETERMINATION

For the eight end-of-line sampling locations, the waste flow rates will be determined by direct measurement procedures or engineering estimates, as appropriate. Table 2 summarizes information about the chosen methods of flow calculation, by sample location..

TABLE 2
METHODS OF FLOW DETERMINATION

Location 1.0.	Flow Determination Methodology
EOL-1	Flow is determined based on a flow meter at the front of the CPS. The volume of any spent caustic used for wastewater neutralization after this flow meter will be added based on usage. Caustic usage will be estimated based on caustic tank gauge readings.
EOL-2	Determined by monitoring the operational time of the oil discharge pump multiplying by the pump's curve design capacity at discharge pressure.
EOL-3	Determined from gauging records from tank 90TK8-60.
EOL-4	The quantity of oil accumulated in wastewater tanks and sent to crude tankage will be determined based on oil thickness measurements taken on each tank at the end of each quarter and after each oil movement. The quantity of oil accumulated during the quarter will then be estimated based on tank strapping information.
EOL-5	The quantity of oil skimmed from wastewater tanks and sent to crude tankage will be determined based on oil thickness measurements taken on each tank at the end of each quarter. The quantity of oil accumulated during the quarter will then be estimated based on tank strapping information.
EOL-6	The quantity of oil skimmed from wastewater tanks and sent to crude tankage will be determined based on oil thickness measurements taken on each tank at the end of each quarter. The quantity of oil accumulated during the quarter will then be estimated based on tank strapping information.
EOL-7	The quantity of oil skimmed from wastewater tanks and sent to crude tankage will be determined based on oil thickness measurements taken on each tank at the end of each quarter. The quantity of oil accumulated during the quarter will then be estimated based on tank strapping information.
EOL-8	Determined based on best professional judgment estimates at the time of generation. Actual flow measurement or tank gauging information will be used whenever available. The benzene generated by maintenance activities will be averaged over the period between events on a going forward basis.

5.0 SAMPLING SCHEDULE

As a minimum, end-of-the-line benzene waste sampling will be conducted on a quarterly basis for EOL locations 1-7. At least 3 samples will be collected and analyzed during each quarter. Wastes generated as EOL 8 will be sampled as generated and may be from a sampling location after waste commingling or be comprised of composite samples if appropriate. The refinery may collect more samples as deemed appropriate to better

characterize the benzene quantities at the sample locations (e.g., benzene concentration of the sample appears to be out of the typical historical range). Flow-weighted average benzene concentrations will be used for multiple samples if flow is determined to be variable (in accordance with Section 7 of the plan).

6.0 SAMPLING PROCEDURES AND ANALYTICAL TESTING METHODS

The Valero Krotz Springs Refinery will conduct benzene waste sampling using the following sampling procedures, in accordance with 40 CFR §61.355(c)(3).

- All samples provided to the laboratory will be contained in 40 mL VOA sampling vials or equivalent;
- For enclosed pipe sampling, a sampling apparatus capable of delivering a sample at less than 10 De to the sample will be used;
- For tank or basin sampling, representative samples will be collected from side taps or by submerging a corked sample collection bottle to the desired level the tank or basin followed by removal of the cork (the sample will then be immediately transferred to an appropriate VOA container);
- If two phases exist, the water phase sample will be collected in one vial and the oil phase sample will be collected in another vial;
- Oil samples from slop oil tanks will be collected from at least two different vertical locations to account for possible tank stratification;
- Sample vials will be completely filled and immediately capped to avoid headspace (no air bubbles); and
- Samples will be maintained at a temperature <10°C until delivery to the laboratory.

The Valero Krotz Springs Refinery will submit collected samples to an analytical laboratory for analysis using one of the following USEPA benzene testing methods, in accordance with 40 CFR §61.355(c)(3)(iv):

- 802o-EPA Publication SW-846;
- 8021-EPA Publication SW-846;
- 824o-EPA Publication SW-846;
- 826o-EPA Publication SW-846;
- 602-40 CFRpart 136, appendix A; or
- 624-40 CFRpart 136, Appendix A.

The refinery will follow chain-of-custody procedures and will maintain these records with the analytical results.

7.0 CALCULATION METHODS

7.1 FLOW-WEIGHTED QUARTERLY BENZENE CONCENTRATION

All benzene results collected from sample locations identified in this plan during a quarter will be utilized in the calculations, except as discussed in Section 7.3 (Outlier Data).

If waste flow is constant, the flow-weighted concentration is the average concentration of all samples from a particular location. If waste flow is not constant, concentration will be adjusted to reflect flow using the following equation, which is consistent with the test procedures of 40 CFR 61.355(c)(3)(v).

$$\bar{C} = \frac{1}{Q_t} \times \sum_{i=1}^n (Q_i)(C_i)$$

Where:

C = Flow-weighted quarterly average benzene concentration for waste stream (ppmw)

Q_t = Total quarterly waste quantity for waste stream (Mgal/calendar quarter)

n = Number of waste samples

Q_i = Quarterly waste quantity for waste stream represented by C; (Mgal/calendar quarter)

C_i = Measured concentration of benzene in waste sample *i* (ppmw)

, Example 1 in Appendix B illustrates the calculation of a flow-weighted quarterly benzene concentration using the above-referenced equation.

7.2 QUARTERLY AND ANNUAL BENZENE PROJECTIONS

The quarterly and annual benzene projections are based on the benzene contained in the water and oil phases of all six sample locations. The following equation illustrates the total benzene calculation.

$$Q_b = \sum_{i=1}^m \left(Q_i^{water} \times \bar{C}_i^{water} \right) + \sum_{i=1}^n \left(Q_i^{oil} \times \bar{C}_i^{oil} \right)$$

Where:

Q_b = Total quarterly (or annual) benzene quantity (Mg/calendar quarter)

m = Number of waste streams with water phase

Q_i^{water} = Quarterly (or annual) water quantity for waste stream represented by C_i^{water} (Mg/calendar quarter)

\bar{C}_i^{water} = Flow-weighted quarterly average benzene concentration in a water phase of waste stream i (ppmw)

n = Number of waste streams with oil phase

Q_i^{oil} = Quarterly (or annual) oil quantity for water phase waste stream represented by C_i^{oil} (Mg/calendar quarter)

\bar{C}_i^{oil} = Flow-weighted quarterly average benzene concentration in an oil phase of waste stream i (ppmw)

Example 2 in Appendix B illustrates the calculation of a total quarterly benzene quantity using the above referenced equation.

Adjustments may be made to the quarterly or annual projections based upon process knowledge. As an example, if an elevated quarterly projection is due to an event that is not

expected to recur, the annual projection may be adjusted down to reflect this fact. Any such adjustments will be explained in the quarterly report submitted to EPA.

7.3 OUTLIER DATA

Any benzene results from aqueous samples that are in excess of 200 ppm will be assumed to be the result of hydrocarbon contamination. This is based upon Valero and EPA's experience that benzene in refinery wastewater samples is rarely found in excess of 80 ppm. This low solubility is due to the other organics and salts that are also present in solution.

If a result is obtained for an aqueous sample that is suspect, but is less than 200 ppm, Valero shall immediately resample the stream. If the results of the second sample are less than 10% of the first result, then the first result will be determined to be erroneous. Otherwise, it will be used along with any additional results that are obtained for this stream during the quarter to determine the average quarterly benzene concentration.

If Valero determines that the results from any aqueous or organic sample are outliers based on additional information, evaluation or analysis, the basis for this claim will be explained in the quarterly report submitted to EPA.

8.0 REPORTING REQUIREMENTS

The Valero Krotz Springs Refinery will submit quarterly benzene determination results to the USEPA as required by consent decree.

APPENDIX A
ENDaOF-LINE SAMPLING LOCATIONS & BLOCK FLOW
DIAGRAM

APPENDIX B
EXAMPLE CALCULATIONS

EXAMPLE 1

Refinery A has one end-of-line (EOL) sampling location. During the 3rd quarter of 2001, Refinery A conducted three sampling events at the EOL point. The sampling events were conducted on July 15, at 20-minute intervals. During each sampling collection event, the waste stream at the EOL point had both water and oil phases. Refinery A collected representative water and oil phase samples during each sampling event. These samples were submitted to a laboratory for benzene analyses. In addition, Refinery A determined water and oil phase flows that occurred at the EOL point during each sampling event. Refinery A also determined total water and oil phase flow at EOL point for the 3rd quarter of 2001. Refinery A summarized all of the above-referenced data in table below.

REFINERY A
EOI SAMPLING DATA FOR 3RD QUARTER OF 2001

Parameter/Unit	July 15, 01 Sample 1	July 15, 01 Sample 2	July 15, 01 Sample 3
Benzene concentration in water phase (ppmw)	20	30	25
Benzene concentration in oil phase (ppmw)	500	350	400
Water flow at EOL point (Mg/calendar quarter)	19,500	19,100	19,600
Oil flow at EOL point (Mg/calendar quarter)	22	30	35

The following equation illustrates calculation of flow-weighted quarterly average benzene concentration in a water phase of the waste stream.

$$\underline{C}_{water} = \frac{1}{19,500 + 19,100 + 19,600} \times (20 \times 19,500 + 30 \times 19,100 + 25 \times 19,600) = 25 \text{ ppmw}$$

The following equation illustrates calculation of flow-weighted quarterly average benzene concentration in an oil phase of the waste stream.

$$\bar{C}^{oil} = \frac{1}{22+30+35} (500 \times 22 + 350 \times 30 + 400 \times 35) = 408 \text{ Ppmw}$$

EXAMPLE 2

Total quarterly benzene quantity for Refinery A (see Example 1 for Refinery A's data) is calculated in the following manner.

$$Q = \frac{(19,400 \times 25) + (29 \times 408)}{10^6} = 0.50 \text{ Mg / calendar quarter}$$

Figure I - End of Line Sampling Locations

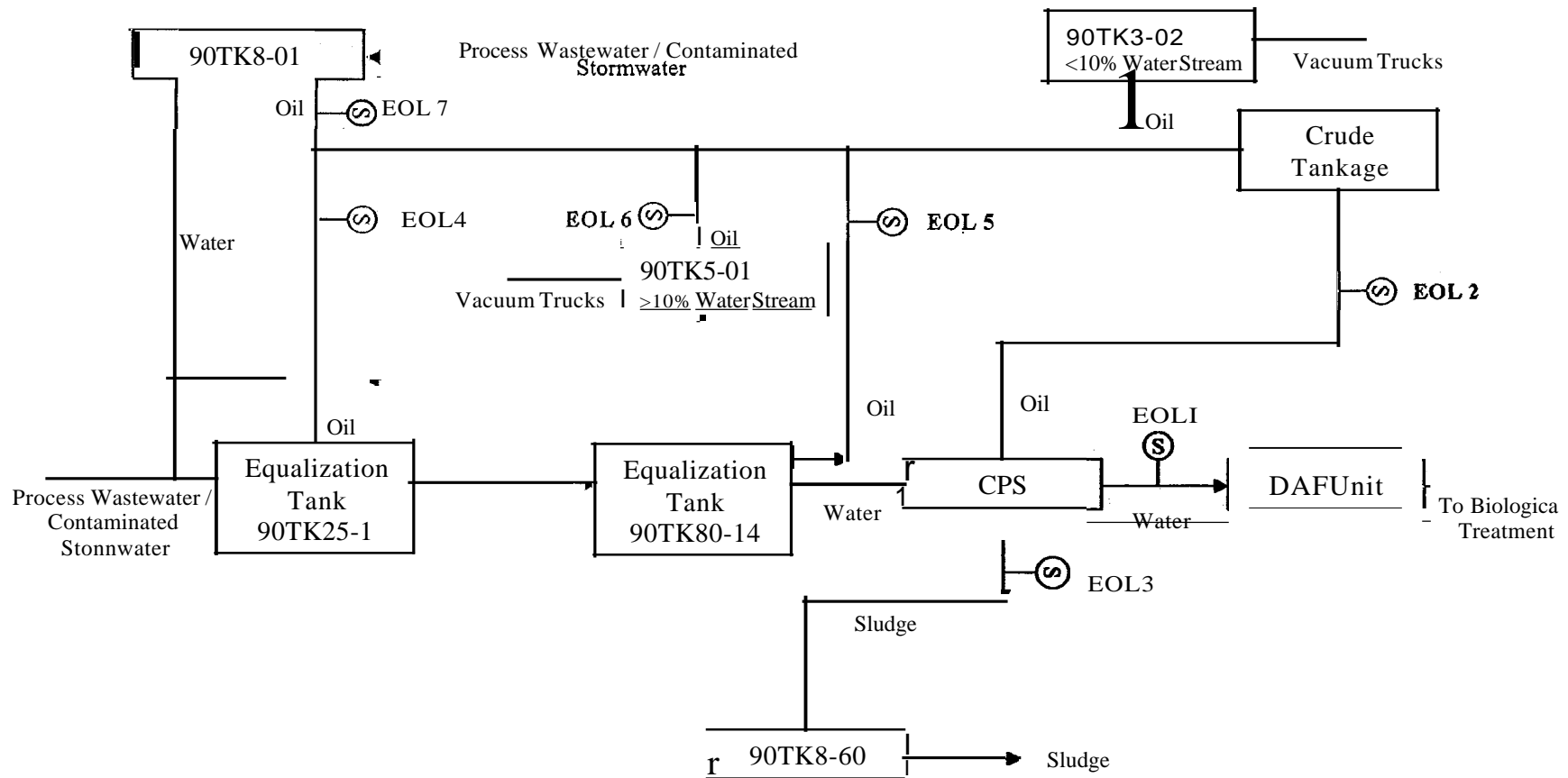

EOL-8 Maintenance and process related wastes not routed through EOL 1-7. These streams will be included in the end-of-line calculation as generated. Examples might include wastes from tank cleaning or turnaround activities

 - Designates EOL Sample Location

APPENDIXH
Reserved

11/1/05

APPENDIX I
Sustainable Skip Period Program

The following skip rules will apply in lieu of 40 C.F.R. § 63.168(d)(2)-(4) and 40 C.F.R. § 60.483-2(b)(2)-(3).

1. Valero or Tesoro may move to less frequent monitoring on a unit-by-unit basis using the following criteria:
 - a. At process units that have less than 2 percent leaking valves for 2 consecutive months, the owner or operator shall monitor each valve once every quarter, beginning with the next quarter.
 - b. After 2 consecutive quarterly leak detection periods with the percent of leaking valves less than or equal to 1 percent, the owner or operator may elect to monitor each valve once every 2 quarters.
 - c. After 3 consecutive semi-annual leak detection periods with the percent of valves leaking less than or equal to 0.5 percent, the owner or operator may elect to monitor each valve once every 4 quarters.

2. Valero or Tesoro must return to more frequent monitoring on a unit-by-unit basis using the following criteria:
 - a. If a process unit on a quarterly, semi-annual or annual monitoring schedule has a leak percentage greater than or equal to 2 percent in any single detection period, the owner or operator shall monitor each valve no less than every month, but can again elect to advance to less frequent monitoring pursuant to the schedule in 1, above.
 - b. If a process unit on a semi-annual or annual monitoring schedule has a leak percentage greater than or equal to 1 percent, but less than 2 percent in any single detection period, the owner or operator shall monitor each valve no less than quarterly, but can again elect to advance to less frequent monitoring pursuant to the schedule in 1, above.
 - c. If a process unit on an annual monitoring schedule has a leak percentage greater than or equal to 0.5 percent but less than 1 percent in any single detection period, the owner or operator shall monitor each valve no less than semi-annually, but can again elect to advance to less frequent monitoring pursuant to the schedule in 1, above.



APPENDIXJ
Reserved

ADP

APPENDIXK
Acid Gas Flaring Devices

<u>Refinery</u>	<u>Acid Gas Flaring Device</u>
Ardmore	East Flare (Crude Flare) OldEastFlare
Benicia	Acid GasFlare
Corpus Christi East	No 1 SRUEmergency Flare No 2 SRUEmergency Flare SWS Emergency Flare
Corpus Christi West	Acid GasFlare
Denver	Refinery Flare
Houston	Derrick Flare Isomax Flare FCC Flare
Krotz Springs	Crude UnitFlare FCC Unit Flare
McKee	Refinery Flare
Paulsboro	Old South Flare New South Flare North Flare Spare North Flare
St. Charles	Flare I Flare 2
Texas City	Flare No.2 Flare No.3 Flare No.4 Emergency Flare No. 193A
Three Rivers	FCC Flare HCUFlare
Wilmington	Phase 0 Flare
Golden Eagle	Ammonia Plant Flare East Air Flare West AirFlare North Stream Flare South Stream Flare

Emergency Flare

AM

APPENDIX L
REGENERATIVE SCRUBBER AND BENICIA WGS DESIGN AND OPTIMIZATION

All air pollution control equipment designed pursuant to this Appendix will be designed, built, and operated in accordance with accepted engineering practice and any regulatory requirements (e.g. any limitations on wastewater processing) that may apply.

A. Design Considerations

1. Absorber Vessel

- a. Volume
- b. Dimensions
- c. Pressure Drop
- d. Internal Configuration
- e. Location in Process Train

2. Scrubbing Liquor

- a. Type.
- b. Scrubbing Liquor Blowdown/Makeup
- c. Scrubbing Liquor Circulation Rate
- d. Scrubbing Liquor pH

3. Flue Gas Characteristics

- a. Inlet/Outlet S02/S03 Concentrations
- b. Flue Gas Volumetric Flow
- c. Inlet/Outlet Temperature Range
- d. Inlet/Outlet Particulate Loading and Characteristics

4. Efficiency

- a. Designed to Outlet S02/S03 Concentration
- b. Designed to Removal Efficiency

5. Safety Considerations

B. Optimization Parameters

1. Scrubbing Liquor

- a. Type
- b. Scrubbing Liquor/Caustic Blowdown/Makeup
- c. Scrubbing Liquor Circulation Rate



d. Scrubbing Liquor pH

2. Flue Gas Characteristics

- a. Inlet/Outlet *SO₂* Concentrations
- b. Flue Gas Volumetric Flow
- c. Inlet/Outlet Temperature Range
- d. Inlet/Outlet Particulate Loading and Characteristics

3. Efficiency

- a. Actual Outlet *SO₂* Concentration
- b. Actual Removal Efficiency

4. Safety Considerations

Handwritten signature or initials in black ink, appearing to be 'D. W.' or similar.

APPENDIXM
Reserved

L.

45

APPENDIXN
Hydrocarbon Flaring Devices

Ardmore	Texas City
East Flare (Crude Flare)	Flare No 1
West Flare	Flare No 2
Old East Flare	Flare No 3
Old West Alky Flare	Flare No 4
	Flare No 5
Denver	
Refinery Flare	Houston
LPG Flare	Derrick Flare
	Isomax Flare
McKee	FCC Flare
Refinery Flare	
FCC Flare	Benicia
HCU Flare	Butane Tank Flare
Wastewater Treater Flare	South Flare
	North Flare
Three Rivers	
No 1 West Plant Flare	Krotz Springs
No 2 West Plant Flare	Crude Unit Flare
FCC Flare	FCC Unit Flare
HCU Flare	
Wastewater Treater Flare	Paulsboro
	Old South Flare
Wilmington	New South Flare
East Plant Phase 2 Flare	North Flare
West Plant Phase I Flare	Spare North Flare
LPG Flare	
Corpus East	Golden Eagle
Complex 8 Flare	Air Flare
Complex 7 Flare	Tank 691 Safety Flare
Complex 6 Flare	West Air Flare
	North Steam Flare
Corpus West	South Steam Flare
BUP Flare	Emergency Flare
Main Flare	
Ground Flare	St. Charles
	Flare I
	Flare 2

DX

APPENDIX 0
Specific Heater and Boiler NSPS Schedule

Refinery	Heater/Boiler	NSPS Compliance Date
Texas City	H-28 Alkylation Heater	December 31,2010
	H-57 Coker Heater	December 31,2010
	H-58 Coker Heater	December 31,2010
Benicia	F-801 Cat Naphtha Hydrofiner Heater	December 31, 2010
Golden Eagle	F-8	December 31, 2010
	F-9	December 31, 2010
	F-12	December 31, 2010
	F-13	December 31, 2010
	FCC Startup Heater	December 31, 2010

APPENDIX
Truck and Vehicle Emission Reduction SEPs

Project Criteria: Each Federal Truck and Vehicle Emission Reduction SEP shall satisfy each of the following criteria:

1. To reduce emissions of particulates and/or ozone precursors, it shall involve either: (a) the retrofit of high-emitting, in-service heavy duty diesel vehicles with emissions control equipment or the replacement of their engines; (b) the replacement of conventional vehicles with zero/low emission vehicles; or (c) idle control programs at its truck stops or the truck stops of others.

2. It shall cover either the hardware and installation costs or the incremental additional cost of zero/low emission vehicles over convention vehicle replacement(s), and may also provide for incremental maintenance costs and/or costs of repairs on such hardware or vehicles (but limited to costs directly related to their low/zero emitting character) for a period of up to four years after installation.

3. Except with respect to Criteria I(c), it shall involve vehicles that are operated an average of at least four days per week and shall cover fleets for which the affected municipality, other local governmental entity or other owner/operator has committed to: (a) maintain equipment installed or vehicles provided in connection with the SEP during and after completion of the SEP; (b) use ultra low-sulfur diesel fuel with the affected vehicles during and after completion of the SEP (if applicable); and (c) to take steps to achieve additional emissions reduction benefits in connection with the project, to the extent feasible (e.g., implementing an idle control program).

4. An affected municipality, other local government entity or other owner/operator whose fleet may be retrofitted using SEP funds under Criteria I(a) may also propose the use of additional SEP funds to: (a) procure tanks or other infrastructure required to enable that fleet to obtain and use ultra low-sulfur diesel fuel ("ULSD"); and (b) offset higher fuel costs incurred by that entity that result from the requirement to use ULSD by the retrofitted fleet (if applicable). Use of SEP funds for ULSD-related purposes may be permissible up to June 1, 2006. Priority shall be given to proposals for which additional funding for ULSD-related costs is provided by other sources.

Reservation: EPA reserves the right to reject all or part of any project that could be funded by EPA under Section 103 of the Clean Air Act or that is otherwise inconsistent with its SEP Policy, applicable guidance or any other provision of law.



With respect to the enforcement matters identified below, entry of this Consent Decree shall resolve all civil liability to the United States and the Plaintiff-Interveners for the violations specifically identified, alleged and/or resolved (in the manner and to the extent set forth herein and in the referenced enforcement documents but only to the extent Valero is in continuing compliance with such resolution), from the date that the claims of the United States and the Plaintiff-Intervener accrued up to the Date of Lodging or the relevant Post-Lodging Compliance Date(s), if applicable.

I. CALIFORNIA

Refinery

A. Outstanding

Outstanding Notices of Violation from the BQMD are not part of this Appendix Q

B. Prior 114 Requests

Section 114 Request from the EPA March 2000

C. Inspections Areas of

None

Wilmington Refinery

A. Outstanding Enforcements

Outstanding Notices of Violation from the SCAQMD are not part of this Appendix Q

B. Prior 114 Requests

None

C. Inspections Areas of Concern

None

II. COLORADO

Denver Refinery

A. Outstanding Enforcements

911512001	NOV (CDPHE) Gaps in seal on UAPI & LAP! Subpart J dispute on equipment failure venting to flare (mechanical seals on pumps).
111172004	Compliance Advisory exceeded 10-year inspection on KbTk. No 30 day notice prior to refiling 2 Kb tanks. Loading trucks w/o flare operating. No performing adequate inspections on QQQ sewers and using kerosene instead of water for sewer seals.

B. Prior 114 Requests

None

C. Inspections Areas of Concern

None

III. LOUISIANA

Krotz Springs Refinery

A. Outstanding Enforcements
 None

B. Prior 114 Request
 Section 114 Request EPA 2000
 Section 114 Request EPA August 2004

C.
 All deviations/exceedances concerning permit for the FCCU regenerator stack reported in letters dated January 2, November 26, December 2, December 4, December 5, December 23 and December 26, 2002, and in letters dated February 6, February 25, March 3, 6, March 10, 17, April 29 and April 30, 2003.
 All deviations/exceedances concerning a 2/6/04 flaring event reported in a letter dated February 10, 2004.

St. Charles Refinery

A. Outstanding Enforcements

12/21/2004	NOV (DPsq)	Delayed release notification on sulfur dioxide
8/8/2001	WEQ COINOPP	AE-CN-01-0191; A.I. No. 26003
3/19/2002	WEQ COINOPP	MM-CN-01-0054; A.I. No. 26003
8/29/2002	WEQ COINOPP	MM-CN-02-0029; A.I. No. 26003
7/23/2002	NOV	EPA Rezon 6

B. Prior 114 Requests
 Section 114 request EPA dated March 16, 2001.

C. Inspections! Areas of Concern
 Incident Report dated September 30, 2004, in connection with August 16, 2004 flaring event.
 Incident Report dated July 23, 2004, in connection with a June 4, 2004 flaring event.
 Incident Report dated April 16, 2004, in connection with a February 29, 2004 flaring event.
 Incident Report 12, 2004, in connection with a March 6, 2004 flaring event.
 Follow-up Incident Report dated October 24, 2003, in connection with a September 7, 2003 sax release (incident report dated September 12, 2003).
 Follow-up Incident Report dated July 2, 2004, in connection with a May 14, 2004 flaring event (incident report dated May 21, 2004).
 Follow-up Incident Report dated August 27, 2004, in connection with a July 14 & 21 flaring event (Incident Report dated July 21, 2004).
 Follow-up Incident Report dated July 23, 2004, in connection with a June 5, 2004 sax release (Incident Report dated June 11, 2004).
 Follow-up Incident Report dated February 12, 2004, in connection with a February 5, 2004 hydrocarbon release.
 All deviations/exceedances reported in the Title V semi-annual report/Title V annual compliance certification dated March 31, 2004.
 All deviations reported in the NSPS Subpart QQQ report dated April 30, 2004 and July 30, 2004.
 All deviations reported in the Quarterly CEMS report dated May 5, 2004
 All deviations reported in the Quarterly CEMS report dated July 30, 2004
 All deviations reported in the WAR report dated July 30, 2004.
 All deviations reported in the Title V semi-annual monitoring report dated September 29, 2003.
 All deviations/violations reported in the WAR report dated April 30, 2004.
 Any deviations reported in the CEMS report dated March 31, 2004.
 EPA Notice of Violation dated July 23, 2002.

APPENDIX Q
RESOLVED ENFORCEMENT MATTERS

IV. NEW JERSEY

Paulsboro Refinery

A. Outstanding Enforcement

5/15/2000	Admin. Consent Order	AEA 990002-55006 dated May20, 1999 (nopenalty); AEA 9900003-55006 dated May20, 1999 with a \$10,000 penalty; and PEA000001-5506 dated February 3,2000 with a penalty of \$20,000, all of which wereresolved in Adminstrative Consent Order entered into with the State of New Jersey, dated May 5, 2000. Several issues regarding the 2000 ACO are under appeal including twostack emission tests and the issuance of a PSD permit.
5/31/2001	Demand Letter	Demand letter for stipulated penalties for ammonia exceedances.
5/13/2001	Demand Letter	Demand letter for stipulated penalties of \$50,000 for stack test failures on 9/25/01 and 12/27/01.
4/19/2002	AONOCAPA NJDEP	PEA020003-55006; \$64,200 penalty.
5/30/2002	AONOCAPA NJDEP	PEA020005-55006 (amending PEA020001-55006; \$44,200 penalty).
7/17/2002	AONOCAPA NJDEP	PEA020008-55006 (amending PEA020004-55006); \$10,000 penalty.
12/11/2002	AONOCAPA NJDEP	PEA020009-55006; \$25,200 penalty.
5/24/2002	AONOCAPA NJDEP	PEA020002-55829; \$19,000 penalty.
12/15/2002	AONOCAPA NJDEP	PEA020005-55829; \$800 penalty.
9/19/2002	AONOCAPA NJDEP	PEA020006-55829; \$400 penalty.
9/19/2002	AONOCAPA NJDEP	PEA020007-55829; \$15,000 penalty.
9/26/2002	AONOCAPA NJDEP	PEA020008-55829; \$68,400 penalty.
12/11/2002	AONOCAPA NJDEP	PEA020011-55829; \$217,500 penalty.
12/11/2002	AONOCAPA NJDEP	PEA020012-55829; \$7,200 penalty.
12/11/2002	AONOCAPA NJDEP	PEA020014-55829; \$9,700 penalty.
4/11/2003	AONOCAPA NJDEP	PEA030001-55829; \$21,000 penalty.
3/19/2003	AONOCAPA NJDEP	PEA030002-55829; \$72,000 penalty.
11/13/2004	AONOCAPA NJDEP	PEA040001-55829 (amending PEA030005-55829); \$37,000 penalty.
8/2/2003	AONOCAPA NJDEP	PEA030007-55829; \$1,600 penalty.
8/17/2003	AONOCAPA NJDEP	PEA030008-55829; \$4,300 penalty.
7/8/2003	AONOCAPA NJDEP	PEA030009-55829; \$3,000 penalty.
8/17/2003	AONOCAPA NJDEP	PEA030010-55829; \$7,200 penalty.
10/12/2003	AONOCAPA NJDEP	PEA030011-55829; \$10,000 penalty.
11/3/2003	Admin. Consent Order	10/12/03 demand for stipulated penalties of \$50,000 for 9/26/02 stack test (not resolved; Valero appealed).
11/21/2003	AONOCAPA NJDEP	PEA030012-55829; \$4,500 penalty.
11/25/2003	AONOCAPA NJDEP	PEA030013-55829; \$5,000 penalty.
12/14/2003	AONOCAPA NJDEP	PEA030014-55829; \$9,000 penalty.
12/12/2003	AONOCAPA NJDEP	PEA030015-55829; \$4,000 penalty.
11/31/2005	AONOCAPA NJDEP	PEA040002-55829; \$19,800 penalty.
3/14/2005	AONOCAPA NJDEP	PEA050002-55829; \$180,000 penalty.
2/4/2005	AONOCAPA NJDEP	PEA050003-55829; \$90,600 penalty.
1/31/2005	AONOCAPA NJDEP	PEA050005-55829; \$6,000 penalty.
3/15/2005	AONOCAPA NJDEP	PEA050008-55829; \$74,000 penalty.
2/4/2005	AONOCAPA NJDEP	PEA050010-55829; no penalty.

Paukhoro Refinery		
2/23/2005	Admin. Consent Order	2/23/05 demand for stipulated penalties of \$50,000 for 9/24/03 test (not resolved; Valero appealed).
2/17/2005	AONOCAPA NJDEP	PEA050011-55829; \$21,500 penalty.
2/19/2005	AONOCAPA NJDEP	PEA0500012-55829; \$4,000 penalty (not resolved; parties to confirm appeal).
4/15/2005	Admin. Consent Order	NEA030001-55829, Resolution of outstanding violations as described above and as provided in the Administrative Consent Order dated April 18, 2005, which includes for purposes of this Appendix Q, established compliance plans and compliance dates.

Notwithstanding paragraph 35 of the Consent Decree, nothing in this Consent Decree shall be construed to limit the State of New Jersey to additional action(s) if the State of New Jersey determines that such actions are necessary to protect public health, safety, welfare and the environment. Nothing in this Consent Decree shall constitute a waiver of any statutory or common law right of the State of New Jersey to require such additional measures should the State of New Jersey determine that such measures are necessary. Nothing in this Consent Decree shall preclude the State of New Jersey from taking an administrative or judicial action against Valero Refining Company - New Jersey for matters other than the air pollution matters set forth in this Consent Decree.

B. Prior 114 Requests
 Section 114 Request from EPA March 2000

C. Areas of Concern
 Refinery Initiative Inspection by EPA Region II in August 2004, except for potential MACT I violators,

V. OKLAHOMA

Ardmore Refinery

A. Outstanding Enforcements

DATE	ENFORCEMENT ACTION	ALLEGED VIOLATION
11/8/2004	NOV (ODEQ)	ODEQ alleges that Ardmore Refinery failed to monitor 2 Group I storage vessel primary and secondary seals within 60-months and 12-months respectively.
6/19/2004	NOV (ODEQ)	3 Violations - Valero in non-compliance with the following rules & regulations. 60.482-6 & 60.482-7(a) by failing to conduct monthly monitoring on each valve of the CFHT, Amine and LD Dock process units and failing to equip 10 open-ended lines with a cap, blind flange, plug or second valve and 60.483-2(b)(5) by including non-subject equipment in the leaking valve percent calculations
3/12/00	Administrative Consent Order (ODE)	All matters resolved in Administrative Consent Order entered into with State of Oklahoma.

B. Prior 114 Requests
 None

C. Inspections / Areas of Concern
 None

VI. TEXAS

Corpus Christi

A. Outstanding Enforcements

DATE	NOE	CE
12/28/2004	NOE	CE
12/2/2004	NOV	CE
8/19/2004	NOV	CE
7/19/2004	NOE	CE
4/14/2004	NOE	CE
1/6/2004	NOE	CE
8/28/2003	NOE	CE
3/19/2002	NOV	CE

B. Prior 114

Section 114 Request EPAMarch 2000

C. Areas of Concern

None

Corpus Christi Refinery

A. Outstanding Enforcements Matters

DATE	NOE	CE
10/22/2004	NOE	CE
8/16/2004	NOV	CE
7/1/2004	NOV	CE
8/12/2003	NOV	CE
6/27/2003	NOV	CE
12/17/2001	NOE	CE

B. Prior 114

Section 114 Request from EPAMarch 2000

C. Areas of Concern

None

Refinery

A. Outstanding Enforcements

DATE	NOE	CE
1/3/2005	NOE	CE
12/30/2004	NOV	CE
12/30/2004	NOE	CE
12/30/2004	NOE	CE
12/30/2004	NOE	CE
12/30/2004	NOE	CE
12/30/2004	NOE	CE
12/30/2004	NOE	CE
12/30/2004	NOE	CE
11/30/2004	NOV	CE
11/29/2004	NOV	CE
9/14/2004	NOE	CE

B. Prior 114 Requests

None

C. Inspections/Areas of Concern

None

Houston Refinery

A. Outstanding Enforcements Matters

11/6/2005	NOE	BAOC
12/30/2004	NOE	BAOC
12/29/2004	NOE	BAOC
12/22/2004	NOE	BAC
12/22/2004	NOE	BAC
11/22/2004	NOE	BAC
11/17/2004	NOE	BAC
11/12/2004	NOE	BAC
11/4/2004	NOE	BAC
10/15/2004	NOE	BAC
8/31/2004	NOE	BAC
8/26/2004	NOE	BAC
8/26/2004	NOE	BAC
8/16/2004	NOE	BAC
8/16/2004	NOE	BAC
7/29/2004	NOV	BAC
5/27/2004	NOE	AC
5/27/2004	NOE	AC
5/27/2004	NOE	AC
5/19/2004	NOV	AC
5/14/2004	NOE	BAC
5/6/2004	NOE	BACQ
4/28/2004	NOE	BAC
4/28/2004	NOE	BAC
4/12/2004	NOE	BAC
4n12004	NOV	BACC
4n12004	NOV	BACC
3/3/2004	NOE	BAC
2/25/2004	NOV	AC
11/26/2004	NOE	AC
11/24/2003	NOE	AC
11/7/2003	NOE	ACQ
10/24/2003	NOE	BA C
9/19/2003	NOE	BA C
8/29/2003	NOE	BA C
7/25/2003	NOE	BA C
7/8/2003	NOE	BA C
7/3/2003	NOE	BA C
5/30/2003	NOE	BA
4/30/2003	NOE	TCE
4/23/2003		TCE
3/6/2003	NOE	TCE
11/4/2002	NOE	TCE
9/5/2002	NOE	CE
4/9/2002	NOE	TCE

B. Prior 114 Requests
 Section 114 Request from EPA March 2000

C. Inspections/Areas of Concern
 None

City Refinery

A. Outstanding Enforcement Matters

3/31/2005	NOE	TCE
1/31/2005	NOV	TCE
1/24/2005	NOE	TCE
1/12/2005	NOE	CE
1/10/2005	NOE	CE
1/10/2005	NOE	CE
1/10/2005	NOE	CE
1/6/2005	NOE	CE
1/6/2005	NOE	CE
1/6/2005	NOV	CE
1/4/2005	NOE	CE
1/4/2005	NOE	TCE
12/28/2004	NOV	CE
12/10/2004	NOV	CE
8/31/2004	NOV	CE
8/31/2004	NOV	CE
8/31/2004	NOV	CE
8/28/2004	NOV	TCE
3/4/2004	NOV	(f)CE
3/2/2004	NOV	(f)CE
7/8/2002	NOE	TCE
5/15/2002	NOV	(f)CE
1/17/2001	NOV	(f)CE
10/12/2001	NOV	TCE
7/6/2001	NOE	TCE

B. Prior 114 Requests

Section 114 Request from EPA March 2000

C. Inspections Areas of Concern

EPA compliance investigation reported August 1996, as it related to NESHAP Subpart FF and the handling of the Marathon Sour Water Stripper and nch aminestreams.
 EPA Air Inspection of April 19-22, 1999 and May 25-28, 1999

Three Rivers Refinery

A. Outstanding Enforcement Matters

8/30/2002	NOV	CEQ
7/31/2002	NOE	CEQ
2/11/2002	NOV	CEQ
1/30/2002	NOE	TCEQ
1/23/2002	NOV	(f)CEQ

B. Prior 114 Requests

None

C. Inspections Areas of Concern

None

APPENDIXR
Mobile Source Provisions

1. The claims asserted by or available to the United States and/or Plaintiff-Interveners to which the "effect of settlement" provisions of Paragraph 354A of the Consent Decree apply including the follow:
 - a. Alleged failure to comply with the annual average oxygen content standard as set forth in a report to EPA submitted November 15, 1999.
 - b. Alleged failure to comply with the annual average oxygen content standard at the Texas City Refinery for report year 2000.
 - c. Alleged failure to comply with the average oxygen content standard at the Houston Refinery for report year 2000.
 - d. Alleged violation of the maximum pergallon olefin content standard on October 12, 1999.
 - e. Alleged exceedances of the applicable Reid Vapor Pressure standard on September 1, 2000 (Houston Refinery), August 24, 2001 (Houston Refinery), April 30, 2000 (Ultramar PADD 1 facility), and April 30, 2001 (Ultramar PADD I facility).
 - f. Alleged exceedances of the applicable E-200 fuel property range on or about November 28, 2001.
 - g. Alleged violations set forth in the Valero attest audits for 2001-2003.

2. To increase awareness of obligations to comply with federal and state mobile source regulations, Valero has formed a Clean Fuels Implementation Team consisting of representatives from its affiliates and subsidiaries' organizations. A copy of the charter for the CFIT outlining current roles and responsibilities and membership is attached to this Appendix. For the duration of this Consent Decree, Valero shall continue to support and operate the CFIT.

DPL

CFIT - Structure

- Location - Corporate
- Meetings - Monthly
- Membership - One representative from each of the following departments:

Corp. Engr. & Tech
Planning & Economics
Internal Audit
Regulatory Affairs
Environmental Law
Retail
Wholesale
Refined Products Trading
Product Control
Planning & Economics
Refinery Operations

CFIT - Charter

Purpose

- Facilitate communication and compliance with issues pertaining to fuels regulations
- Act as primary Valero contact with State and Federal EPA on fuels issues
- Source of technical and regulatory knowledge for all functional groups to use in solving compliance and quality control issues

Actions

- Communication -
Serve as primary contact with State and Federal EPA on fuels issues
Issue summary of proposed and new regulations
- Recommendations -
√ Issue recommendations (guidelines for policies and procedures), that have been approved by management
√ Work directly with operations/affected groups on compliance issues

Accountability

- Accountability for compliance with the regulations remains with the line organizations

APPENDIXS

PREDICTIVE EMISSIONS MONITORING SYSTEMS FOR HEATERS
AND BOILERS WITH CAPACITIES BETWEEN 150 AND 100
MMBTU IHR

A Predictive Emissions Monitoring Systems ("PEMS") is a mathematical model that predicts the gas concentration of NO_x in the stack based on a set of operating data. Consistent with the CEMS data frequency requirements of 40 C.F.R. Part 60, the PEMS shall calculate a pound per million BTU value at least once every 15 minutes, and all of the data produced in a calendar hour shall be averaged to produce a calendar hourly average value in pounds per million BTU.

The types of information needed for a PEMS are described below. The list of instruments and data sources shown below represent an ideal case. However at a minimum, each PEMS shall include continuous monitoring for at least items 3-5 below. Valero or Tesoro, as appropriate, will identify and use existing instruments and refinery data sources to provide sufficient data for the development and implementation of the PEMS.

Instrumentation:

1. Absolute Humidity reading (one instrument per refinery, if available)
2. Fuel Density, Composition and/or specific gravity - On line readings (it may be possible if the fuel gas does not vary widely, that a grab sample and analysis may be substituted)
3. Fuel flow rate
4. Firebox temperature
5. Percent excess oxygen
6. Airflow to the firebox (if known or possibly estimated)
7. Process variable data - steam flow rate, temperature and pressure - process stream flow rate, temperature & pressure, etc.

Computers & Software:

Relevant data will be collected and stored electronically, using computers and software. The hardware and software specifications will be specified in the source-specific PEMS.

Calibration and Setup:

1. Data will be collected for a period of 7 to 10 days of all the data that is to be used to construct the mathematical model. The data will be collected over an operating range that represents 80% to 100% of the normal operating range of the heater boiler;
2. A "Validation" analysis shall be conducted to make sure the system is collecting data properly;
3. Stack Testing to develop the actual emissions data for comparison to the collected parameter data; and
4. Development of the mathematical models and installation of the model into the computer.

The elements of a monitoring protocol for a PEMS shall include:

1. Applicability

- a. Identify source name, location, and emission unit number(s);
- b. Provide expected dates of monitor compliance demonstration testing.

2. Source Description

- a. Provide a simplified block flow diagram with parameter monitoring points and emission sampling points identified (e.g., sampling ports in the stack);
- b. Provide a discussion of process or equipment operations that are known to significantly affect emissions or monitoring procedures (e.g., batch operations, plant schedules, product changes).

3. Control Equipment Description'

- a. Provide a simplified blockflow diagram with parameter monitoring points and emission sampling points identified (e.g., sampling ports in the stack);
- b. List monitored operating parameters and normal operating ranges;
- c. Provide a discussion of operating procedures that are known to significantly affect emissions (e.g., catalytic bed replacement schedules).

4. Monitoring System Design

- a. Install, calibrate, operate, and maintain a continuous PEMS;
- b. Provide a general description of the software and hardware components of the PEMS, including manufacturer, type, of computer, name(s) of software product(s), monitoring technique (e.g., method of emission correlation). Manufacturer literature and other similar information shall also be submitted, as appropriate;
- c. List all elements used in the PEMS to be measured (e.g., pollutant(s), other exhaust constituent(s) such as O₂ for correction purposes, process parameter(s), and/or emission control device parameter(s));
- d. List all measurement or sampling locations (e.g., vent or stack location, process parameter measurement location, fuel sampling location; work stations);
- e. Provide a simplified block flow diagram of the monitoring system overlaying process or control device diagram (could be included in Source Description and Control Equipment Description);
- f. Provide a description of sensors and analytical devices (e.g., thermocouple for temperature, pressure diaphragm for flow rate);
- g. Provide a description of the data acquisition and handling system operation including sample calculations (e.g., parameters to be recorded, frequency of measurement, data averaging time, reporting units, recording process);

232

- h. Provide checklists, datasheets, and report format as necessary for compliance determination (e.g., forms for record keeping).

5. Support Testing and Data for Protocol Design

- a. Provide a description of field and/or laboratory testing conducted in developing the correlation (e.g., measurement interference check, parameter/emission correlation test plan, instrument range calibrations);
- b. Provide graphs showing the correlation, and supporting data (e.g., correlation test results, predicted versus measured plots, sensitivity plots, computer modeling development data).

6. Initial Verification Test Procedures

- a. Perform an initial relative accuracy test (RA test) to verify the performance of the PEMS for the equipment's operating range. The PEMS must meet the relative accuracy requirement of the applicable Performance Specification in 40 c.P.R. Part 60, Appendix B. The test shall utilize the test methods of 40 CPR Part 60, Appendix A;
- b. Identify the most significant independently modifiable parameter affecting the emissions. Within the limits of safe unit operation, and typical of the anticipated range of operation, test the selected parameter for three RA test data sets at the low range, three at the normal operating range and three at the high operating range of that parameter, for a total of nine RA test data sets. Each RA test data set should be between 21 and 60 minutes in duration;
- c. Maintain a log or sampling report for each required stack test listing the emission rate;
- d. Demonstrate the ability of the PEMS to detect excessive sensor failure modes that would adversely affect PEMS emission determination. These failure modes include gross sensor failure or sensor drift;
- e. Demonstrate the ability to detect sensor failures that would cause the PEMS emissions determination to drift significantly from the original PEMS value;
- f. The PEMS may use calculated sensor values based upon the mathematical relationships established with the other sensors used in the PEMS. Establish and demonstrate the

number and combination of calculated sensor values which would cause PEMS emission determination to drift significantly from the original PEMS value.

7. Quality Assurance Plan

- a. Provide a list of the input parameters to the PEMS (e.g., transducers, sensors, gas chromatograph, periodic laboratory analysis), and a description of the sensor validation procedure (e.g., manual or automatic check);
- b. Provide a description of routine control checks to be performed during operating periods (e.g., preventive maintenance schedule, daily manual or automatic sensor drift determinations, periodic instrument calibrations);
- c. Provide minimum data availability requirements and procedures for supplying missing data (including specifications for equipment outages for QA/QC checks);
- d. List corrective action triggers (e.g., response time deterioration limit on pressure sensor, use of statistical process control (SPC) determinations of problems, sensor validation alarms);
- e. List trouble-shooting procedures and potential corrective actions;
- f. Provide an inventory of replacement and repair supplies for the sensors;
- g. Specify, for each input parameter to the PEMS, the drift criteria for excessive error (e.g., the drift limit of each input sensor that would cause the PEMS to exceed relative accuracy requirements);
- h. Conduct a quarterly electronic data accuracy assessment tests of the PEMS;
- i. Conduct semiannual RA tests of the PEMS. Annual RA tests may be conducted if the most recent RA test result is less than or equal to 7.5%. Identify the most significant independently modifiable parameter affecting the emissions. Within the limits of safe unit operation and typical of the anticipated range of operation, test the selected parameter for three RA test data pairs at the low range, three at the normal operating range, and three at the high operating range of that parameter for a total of nine RA test data sets. Each RA test data set should be between 21 and 60 minutes in duration.



8. PEMS Tuning

- a. Perform tuning of the PEMS provided that the fundamental mathematical relationships in the PEMS model are not changed.
- b. Perform tuning of the PEMS in case of sensor recalibration or sensor replacement provided that the fundamental mathematical relationships in the PEMS model are not changed.

