



7. Best Practices for Landfill Gas Collection System Design and Installation

Photo credits: Advance One Development, Inc. and Smith Gardner, Inc.

Landfill owners and operators collect landfill gas (LFG) for various reasons, including using LFG for energy, complying with local/state/federal regulations and controlling odors. Regardless of the motivation, owners and operators want to maximize the amount of LFG that is collected while minimizing the amount lost as fugitive or odorous emissions. In general, minimizing fugitive emissions and maximizing collection efficiency improves environmental benefits such as reducing hazardous and greenhouse gas (GHG) emissions and controlling odors and preventing them from migrating off site. Maximizing collection efficiency also improves economic return for LFG energy projects.

This chapter provides an overview of design and installation best practices for a planned gas collection system (GCS). Advantages and disadvantages of GCS components as well as considerations are presented. Owners and operators that install a GCS can use this information to better understand options available and to ensure their GCS is robust and well maintained to minimize surface emissions and system downtime. Each best practice may not be suited for a particular landfill so application must be determined on a site-specific basis. Information in this chapter is not official guidance; rather, it provides general information about GCS components and options for consideration. Owners and operators are responsible for compliance with applicable regulations.

The federal [New Source Performance Standards and Emission Guidelines \(NSPS and EG\)](#) and [National Emission Standards for Hazardous Air Pollutants \(NESHAP\)](#) for municipal solid waste (MSW) landfills require landfills that exceed the size and emission thresholds to install a well-designed and well-operated gas collection and control system (GCCS).

Although the regulations contain specifications for active collection systems and overall operational requirements, they are intended to provide flexibility and allow innovation, recognizing that site-specific factors affect the design of each system.

Federal Subtitle D regulations also require a well-operated GCCS.

GCS design is based on expected LFG generation and a reasonable estimate of how LFG can be collected to meet overall LFG collection and control objectives. The GCS wellfield design outlines the type, placement and spacing of collectors and the lateral and header piping network. Collectors can consist of vertical wells, horizontal wells, leachate management components, under cap collectors and other applicable devices. The design should address the whole of the targeted disposal area, accommodate the maximum LFG generation rates expected over the life of the landfill and provide a degree of redundancy in the event of operational changes.

GCS designs can vary greatly on a regional basis or even a site basis due to types of waste streams accepted, climate, operational goals and waste filling practices. The designer must take these parameters into account to develop an effective and regulatorily compliant GCS.

7.1 Facility Review

Existing Site Conditions

Site conditions and operational goals both influence the design of a GCS. Site conditions such as landfill geometry, moisture, compaction rates, waste types, waste depths, cover soils permeability and final cover all affect GCS design. The greater the moisture within the waste mass, the faster LFG will be generated and the higher the peak LFG generation rate. A more rapid LFG generation rate also leads to a waste mass that tends to settle faster, which may cause damage to collectors that may need to be assessed and potentially replaced. Liquids within the waste mass may decrease the pore space within the waste mass, decreasing the ability of LFG to move to the LFG extraction wells. Thus, landfills with higher moisture content may have a smaller effective radius (or zone) of influence for individual collectors and may require more collectors for the same area of coverage. Conversely, some sites choose to add moisture to promote decomposition, which increases LFG generation but may increase GCS operational costs due to additional wells, increased settlement and larger header sizing.

Physical properties of the waste mass such as waste density (compaction), type and depth vary by site and affect the moisture level and methane generation potential of the landfill. Many sites accept special waste streams such as sludges, ash, construction and demolition (C&D) and liquids, which greatly affect the GCS design, gas generation rates and the suitability of the LFG for beneficial use. For example, gypsum wall board and onions are known to elevate hydrogen sulfide (H₂S) within LFG, which may need to be removed.

The materials used for daily, intermediate and final cover also vary depending on local availability of soils, climate and approvals for alternate cover materials. Daily cover prevents blowing litter and odors and is usually not considered part of the GCS design. Sites that use a low-permeability soil such as clay for daily and intermediate cover can greatly reduce the influence of the LFG collectors and the effectiveness of the GCS. If this low-permeability soil cover is not completely stripped between placement of waste lifts, the waste mass can be isolated from other landfill components, which negatively affects the ability to collect LFG and drain leachate. It also increases the likelihood of LFG emissions and perched leachate (pooling of leachate on top of an impermeable layer) within the waste mass.

At the landfill surface, intermediate and final cover are designed to provide a seal between the landfill and the atmosphere. A more impermeable seal on the surface of the landfill allows more vacuum to be applied to LFG collectors while minimizing the potential for atmospheric air and water to seep into the waste mass and ultimately into the LFG collectors. The more impermeable the intermediate and final cover, the greater the potential well spacing and the better the LFG wells are likely to operate.

Climate

GCS design can vary greatly due to local climatic conditions. The two most critical elements are temperature and the precipitation. Accounting for temperature involves considering how GCS components will respond both during typical and extreme weather events. For example, sites in areas that experience extended temperatures below 0°C (32°F) require freeze protection on equipment and vessels, and all header pipes and laterals should be buried to prevent freezing. Alternately, sites in very warm, sunny areas can have exposed GCS components experience significant thermal movement as they expand during the day and then contract overnight.

Precipitation leads to additional liquids within the landfill. It enters the waste mass through the working face or via percolation through the various cover layers. Landfills in areas of high precipitation should

limit liquids entering the landfill because it can affect LFG generation and/or operation of the GCS. Precipitation can also be a major operating hazard as GCS components can become inaccessible on steep slopes if the surface is too wet or following significant snow fall events. Sites in areas of low precipitation must also consider design and operation. Low precipitation sites experience lower LFG flows, greater areas of influence for the LFG collectors and greater desiccation of the soils that make up the cover, making them more permeable. This often prevents landfills located in very dry climates from producing significant quantities of LFG.

Operational Goals

A GCS is typically designed and operated to collect as much LFG as possible to prevent fugitive emissions and/or maximize collection for beneficial use. Depending on which of these goals is emphasized, the direction of the GCS design and operation could vary. This, coupled with financial impacts from GCS installation and operation, may require a careful balancing of goals and costs as it relates to GCS design, installation and operation.

Each landfill has one or more key operational goals. Below are some of the most common goals and measures landfill owners and operators take to achieve goals.

Maintain Compliance. Landfills that operate a GCS only to maintain compliance with federal, state and/or local requirements are mainly concerned with capturing the gas, controlling gas migration and minimizing fugitive emissions and odors. These sites focus on maximizing collection, however, this often leads to a slight over pull of vacuum on the LFG collectors where atmospheric air intrudes into the collector typically through the cover. The over pull (ambient air intrusion) results in higher concentrations of nitrogen or oxygen in the LFG than would occur otherwise. Provided oxygen levels are maintained below the levels that might lead to a subsurface oxidation event, specific LFG composition percentages are of less importance at a landfill with the goal of compliance.

To control costs, systems operating for compliance can often be implemented with relatively less dense well spacing and therefore fewer wells, while applying a slightly greater vacuum to achieve a larger radius of influence.

Electricity Generation. Landfills that use LFG for electricity generation are concerned with extracting sufficient LFG to operate the electricity generation equipment at full capacity. Unlike sites operating for compliance, sites that are using LFG for electricity generation are concerned with LFG composition. Oxygen at a low level is not an issue for electricity generation equipment but oxygen in sufficiently large quantities can be extremely harmful to the equipment. To control oxygen content and related costs for electricity generation, systems for electricity generation are often implemented with a slightly tighter well spacing (i.e., denser spacing, more wells) than a GCS designed for compliance alone. This allows an electricity generation project's GCS to achieve the collection of LFG with limited over pull.

Medium-Btu Gas Production. Because LFG contains about 50 percent methane, it has about half the energy content of natural gas. Therefore, projects that minimally treat LFG for use as a replacement for fossil fuel are often called "medium-Btu" projects (Btu is British thermal unit). Medium-Btu LFG end uses include a wide range of technologies such as boilers, greenhouses, kilns, dryers and heaters. GCS owners or operators that produce medium-Btu gas are mainly concerned with extracting sufficient LFG to meet the needs of the downstream gas user. Because LFG generally requires minimal conditioning for use as a medium-Btu gas, these systems' operations largely depend on the end user's fuel requirements.

Renewable Natural Gas Production. Landfills that recover LFG for production of renewable natural gas (RNG) focus on extracting sufficient LFG to operate the RNG equipment at full capacity with as few

treatment steps as possible. Unlike sites operating for compliance or electricity generation, sites that are upgrading LFG to RNG are much more concerned about LFG composition. Oxygen and nitrogen at high quantities can be extremely difficult and costly to remove. To control LFG composition and minimize costs for the RNG equipment, these systems are often implemented with significantly tighter well spacing (i.e., denser spacing, more wells) than a GCS for electricity generation or compliance. This allows the RNG project's GCS to collect LFG with limited oxygen or nitrogen resulting from over pull.

Waste Acceptance and Filling Practices

Landfill intake rates, waste composition and working face practices can greatly affect the design of a GCS. Landfills with higher acceptance rates typically generate more LFG and have more settlement of the waste mass, which can negatively affect the GCS components. To ensure the GCS continues to operate, a more frequent replacement plan and schedule are often required for wells, piping and other GCS components at the design stage.

Installation Schedule

The installation and operation of GCS components is often driven in large part by regulatory requirements. The federal NSPS and EG have defined schedules for GCS installation and expansion based on landfill size and emissions. In some cases, it may be advantageous for the landfill owner/operator to install a GCS prior to being required under regulatory criteria. Benefits may include:

- Control of operational odors
- Additional fuel or beneficial use
- Reduction in emissions.

“Early” LFG collection can be implemented within a few months of waste placement, depending on the configuration of the fill area and the rate of waste decomposition, and can be accomplished through a range of techniques and components, including:

- Vertical wells
- Horizontal collectors
- Caisson wells
- Connections to the leachate collection system.

These components are discussed in the following section and should be evaluated for each GCS based upon the specific need of that landfill, the configuration of the fill area, rate of waste placement and any operational concerns that may be present.

7.2 LFG Collectors

Once the review of the landfill is complete, design of the GCS can begin. One of the key components of the GCS is the LFG collectors. LFG collectors are typically composed of slotted or perforated plastic pipe, surrounded by stone or other aggregate backfill material, that are installed in borings (for vertical configurations) or trenches (for horizontal configurations) in the waste mass, below the surface of the landfill. Design considerations for both vertical and horizontal wells, as well as other early collector techniques, are discussed below.

The GCS is not an isolated system and can be affected by other operations within the landfill. For example, proper maintenance and operation of the leachate collection system is critical to the operation of LFG collectors, by keeping the waste mass relatively free draining and allowing LFG to flow through the waste mass and into the LFG collector. Failure to maintain leachate collection system operation can lead to diminished operation of the GCS, regardless of the type of extraction well(s) employed.

Vertical Extraction Wells

As discussed in [Chapter 1](#), vertical wells are the most common well type due to their ability to be installed across most landfill areas and effectively operated to meet a variety of GCS operational goals. Vertical wells have the advantage of being capable of operation as soon as they are installed and being more effective at controlling surface emissions than horizontal collectors. Vertical wells can also be adjusted or “tuned” to accommodate a wide range of operational requirements, including compliance and various utilization goals and to supplement liquids removal. One downside is the need for operators to continue compacting waste around vertical wells installed in operational areas of the landfill and the need to extend or re-drill the wells as waste placement progresses.

The components of a vertical well include the borehole, well casing, backfill materials and well seal.

Boreholes. Vertical well boreholes typically range from 24 inches to 36 inches in diameter. Larger diameter boreholes increase the surface area of the well perimeter, which in turn can increase LFG collection. Larger boreholes also allow additional space for gravel backfill, which can prevent adjacent waste fines from clogging the well casing perforations. Borings less than 24 inches in diameter are generally discouraged as they provide less filter between the waste mass and the well casing and may necessitate the use of smaller well casings. Smaller casings have a reduced structural integrity and limit the ability to remove liquids from the extraction well.

The depth of the boreholes should be based on a reliable source of bottom liner elevation data such as an as-built survey. The as-built survey should be certified by a Registered Land Surveyor or Professional Engineer, and should identify the depth to any geosynthetic components and the elevation top of clay or the top of protective leachate collection media. With modern computer technology, many as-built surveys are now contained in a three-dimensional digital file that allow the user to identify the liner component relatively accurately. The well’s depth should ultimately be no closer than 15 feet to the liner to avoid damaging the liner system. However, if no as-built survey is available, then the buffer should be increased based on known information.

It is critical to generate an accurate survey of the proposed boring location and compare it to known areas of waste deposition (including wet waste, asbestos, other “special” wastes, C&D debris) and previously-constructed GCS components. Impacting any of these items results in varied levels of construction and/or operational concern.

Borehole depths typically range from 40 to 140 feet below the surface of the landfill, but depths can be greater in quarries and canyon fills. The maximum depth achievable is usually limited by the drilling equipment. There are several challenges associated with very deep boreholes, including:

- Vacuum dispersion
- Well integrity (due to higher potential of settlement or crushing)
- High waste compaction, which decreases the waste permeability and inhibits LFG extraction
- High degree of decomposition, which can potentially lead to saturated wastes, borehole collapse and limited LFG extraction.

Well Casing. Vertical well casings typically range from 4- to 8-inch diameter pipe. In addition to collecting more LFG, a larger diameter well casing can decrease the potential for crushing and pinching of the well. Well casing diameters of at least 4 inches can also accommodate retroactive installation of pumps in areas that may require future dewatering.

Vertical well casings are typically constructed of polyvinyl chloride (PVC) or high-density polyethylene (HDPE). In some landfills with elevated temperatures, chlorinated polyvinyl chloride (CPVC) pipe or stainless steel is used for their ability to withstand higher temperatures. Table 7-1 presents considerations for selecting the casing material.

Table 7-1. Well Casing Material Design Considerations

Design Consideration	PVC Pipe	HDPE Pipe
Material Properties	Most suitable for vertical well casing construction due to its strength and temperature resistance. Differential settlement of the waste mass may lead to brittle fracture of the casing, allowing some degree of gas flow through the fracture.	Better suited for horizontal well casing and header and lateral pipe applications due to its flexibility and resistance to crushing. Often used in vertical wells since the piping will deform and bend with settlement. However, severe settlement may pinch the pipe and seal it off, inhibiting LFG flow.
	Material rigidity is susceptible to breaking by heavy equipment; however, field observations have also shown that broken PVC material can still act as a gas conduit.	Does not serve as a gas conduit when pinched.
	Resistant to pinching, elongation and deformation of perforations/slots; however, more vulnerable to ultraviolet radiation and brittleness from low temperatures.	Flexible and able to withstand the inherent shifting of a waste mass; due to the flexible properties of HDPE, perforations/slots are discouraged.
Installation	Fabricated as it is lowered into place; PVC sections, including extensions, are connected via threads or via slip couplings, screws and glue.	Fabricated prior to installation using specialized equipment and trained technicians to fuse sections together.
Temperature	Better suited for high gas temperatures <82°C (180°F).	Not recommended for long-term service above 60°C (140°F).
Cost	Price has remained relatively stable between 2013 and 2018.	Price fluctuates based on petroleum market rates. In 2018, approximately 25 percent higher cost than comparable PVC casing.

In addition to selecting the type of material, the appropriate specification of the pipe, including wall thickness (e.g., Schedule 80 PVC, Standard diameter ratio (SDR) 11 HDPE), resin blend and joining methods are also important to ensure the longevity of the system.¹

The lower portion of the casing material is perforated with holes or slots to collect LFG from the surrounding area. The casing design should ensure that perforations are not too close to the surface to

¹ California Integrated Waste Management Board. Technologies and Management Options for Reducing Greenhouse Gas Emissions From Landfills. April 2008. <https://www2.calrecycle.ca.gov/Publications/Details/1268>.

avoid air intrusion.² In addition, the design should consider if the well will need to be able to accommodate a pump to extract liquids at the time of construction, or potentially be added later. Wells with pumps are often called dual extraction wells for their ability to extract LFG and liquids.

The casing design should specify the spacing and diameter of the perforations both in terms of size and frequency. The specification is typically based on the total square inches of perforations per linear foot of casing to maintain the integrity of the casing material. The U.S. Army Corps of Engineers recommends perforations of 0.5-inch diameter holes spaced at 90 degree angles every 6 to 12 inches or a minimum of 0.1-inch slots.³ Current industry practice utilizes slots of approximately 3/8-inch width to reduce the potential for clogging. The specification of the perforations needs to be coordinated with the backfill around the casing so that the perforations do not permit the stone surrounding the well to enter the casing. Perforation slots can be cut at the landfill, but it is generally more cost-effective to order the pipe fabricated directly from the supplier using tooling purposely designed for this application. If HDPE is used for the casing material, slots are discouraged because the flexible properties of this material can cause the slots to heal over (i.e., close on themselves) at higher temperatures.

The upper portion of the casing is not perforated and should consist of the same size and type of pipe material as the lower, perforated section. The solid portion of the casing should extend approximately 15 to 20 feet below the landfill surface. The depth of solid pipe should be selected in part by considering how much atmospheric air is acceptable to pull into the well. The greater the length of solid pipe, the less amount of air that is likely to be pulled into the well. The well casing should extend a few feet above the ground surface, to provide a visual location for the well and to allow a wellfield technician to monitor, adjust (i.e., tune) and service the well. The casing's exact height above the surface should be determined based on operating and fill practices at the landfill.

The backfill around the well casing is a granular material that allows LFG to enter the perforated portion of the well casing. The granular material, typically gravel or a similar material, is placed around the perforated section of the casing pipe, completely filling the annular space of the borehole. The granular backfill provides lateral strength to the casing to minimize the risk of it being crushed from movement of the surrounding waste due to compaction or settlement. Granular backfill also allows the LFG to move freely from the waste into the well casing and acts as a filter to prevent waste materials from entering the casing. Several factors should be considered when selecting the granular backfill material, including:

- The size of the material should be large enough to act as filter but small enough to not bridge (lodge together and block flow) when being placed. The uniformity of the gradation and the amount of fines (very small particles) should also be considered. The gradation needs to be coordinated with perforated casing.
- Stone should be washed to minimize clogging of the well from dust and fine particles.
- The type of granular material depends on availability and cost but materials that are incompatible with landfill liquids (e.g., carbonate rock such as limestone or cement-based stone) should be avoided.
- Low-carbonate content stone minimizes reaction with landfill liquids, which can contribute to scaling and clogging of the perforations.
- Rounded aggregate, such as pea gravel and river rock, is an ideal material if readily available.

² British Columbia Ministry of Environment. Landfill Gas Management Facilities Design Guidelines. March 2010. <https://www2.gov.bc.ca/assets/gov/environment/waste-management/garbage/designguidelinesfinal.pdf>.

³ U.S. Army Corps of Engineers. Landfill Gas Collection and Treatment Systems Engineer Manual. April 2013. http://www.publications.usace.army.mil/Portals/76/Publications/EngineerManuals/EM_200-1-22.pdf?ver=2013-09-05-152155-217.

- Manmade materials such as tire chips, glass cullet and other waste materials can be used as the granular material in some situations.

Well Seal. The well seal is a plug around the casing where it emerges from the waste and cover material to prevent air and liquids from entering the well from the atmosphere. The amount of vacuum that can be applied to a collector, as well as the overall performance of the GCS, can be limited by the effectiveness of the seal. Several methods or materials are available to ensure a tight well seal, including those listed below. Figure 7-1 shows the installation of bentonite and foam sealants.

Bentonite. Bentonite is a family of clay compounds that expands when wet to serve as an effective seal.⁴ A bentonite seal is typically 3 to 4 feet thick and is placed on top of the granular backfill of the collector.⁵ This seal minimizes infiltration of air from the surface into the collector. For the seal to be effective, it is imperative that the bentonite is sufficiently hydrated during placement. High-swelling materials such as bentonite shrink on dehydration and reduce the effectiveness of the seal and allow air intrusion. Soils over the bentonite seal help keep the moisture within the seal and can decrease the likelihood of the seal desiccating and cracking. For dry sites, a non-bentonite material such as expandable foam or compacted soil should be considered.

Bentonite Slurry. Many landfills use a bentonite slurry to enhance the seal around the collector. When applied around the penetration, the slurry fills the voids that may remain. Hydration is much more thorough and consistent compared to in situ hydration of dry bentonite.

Foam Plug. Generally available as a two-part mix, the foam is mixed at the ground surface and poured into the borehole. The foam then expands to fill the local void space and adhere to the well casing.

Wellbore Seals. This seal is a plastic membrane that slips over the collector's casing and sits on the top of the waste but below the cover soil for interim applications, or is welded to the flexible membrane liner component of the final cover system for permanent applications. A wellbore seal can be used as a redundant seal to complement a bentonite seal; however, it is generally required for sites with composite final cover systems.

A separation media such as a geocomposite, geotextile or other similar material is frequently placed between the granular and soil backfill materials to prevent the materials from migrating into each other and potentially fouling the granular backfill around the perforated casing.

⁴ U.S. EPA, Office of Solid Waste and Emergency Response (5306W). EPA 530-F-97-002. 7/97. Geosynthetic Liners Used in MSW Landfills.

⁵ U.S. Army Corps of Engineers. Landfill Gas Collection and Treatment Systems Engineer Manual. April 2013. http://www.publications.usace.army.mil/Portals/76/Publications/EngineerManuals/EM_200-1-22.pdf?ver=2013-09-05-152155-217.

Figure 7-1. Bentonite and Foam Methods for Sealing a Well

Hydrating bentonite to seal a well



Pouring foam around a well casing

Photos courtesy of Advance One Development, Inc.

Well Spacing. Well spacing is the distance from one well to an adjacent well and typically varies from 150 to 300 feet. Well spacing is a function of the effective radius (or zone) of influence that each well can achieve. Zones of influence typically overlap with adjacent wells to assure coverage of the landfill and collection of LFG. Factors that affect the influence of an LFG well also affect LFG well spacing. These factors include but are not limited to:

- GCS design vacuum for each well
- Waste density
- Liquids within the waste
- Depth of waste
- Proximity to landfill edges
- Cover properties
- Goal of the GCS, e.g., compliance, electricity generation, or RNG facility.

Well spacing at a landfill does not need to be uniform. Variable well spacing takes into consideration the differences between wells within a given landfill. For example, wells closer to the perimeter of the landfill may be more prone to over pull, and thus require a slightly closer well spacing to allow them to achieve coverage while operating under a slightly lower vacuum. Wells within the interior of the landfill, which are less susceptible to air intrusion, may be spaced at a lesser density and operated at a higher rate of vacuum.

Sites that are developing LFG energy projects, specifically RNG projects or others requiring a low degree of balance gas or inert gas (i.e., nitrogen and oxygen), may encounter the operational issue of trying to draw high quality fuel for the end-use project while also maintaining regulatory compliance with surface emission standards. One solution is to decrease the overall well spacing. By locating the wells closer together (typically less than 200 feet apart), the system can be operated efficiently with minimal potential for ambient air intrusion due to over pull of the wells.

Another approach to producing high quality LFG is to establish “production” wells versus “control” wells. Production wells would be developed specifically for producing higher quality fuel. These wells are typically installed in the thicker areas of the waste mass, with a greater length of solid casing (perhaps

greater than 50 feet) to insulate the perforated casing section from ambient influences. Although this creates the conditions for a well to produce consistent fuel with very little balance gas, it does not have the capability of controlling LFG near the surface of the disposal area. To offset this condition, sites can install a shallow control well in the same area specifically for addressing surface emission and odor control for regulatory compliance. Control wells would also include wells in relatively shallow waste along the perimeter of the disposal area, or wells located in older, less productive portions of the site.

Production and control wells are often segregated into separate header piping networks, with production wells directed to the beneficial use facility and the control wells directed to a flare. While this type of program requires additional capital for construction, the benefit of increased revenue from the beneficial use facility is typically greater over the life of the project.

Design Considerations for Converting Passive Vents into Active Vertical Wells. It is becoming increasingly rare for LFG energy development to occur on older closed landfills or inactive cells and inactive landfills, due to the lack of additional waste placement and declining LFG generation. Often there is insufficient LFG generation over a prolonged period to justify the investment in an LFG beneficial use project to achieve positive returns. However, some landfills start with passive vents or a passive GCS to relieve LFG pressure within the landfill. Design of these passive systems should take into consideration that they will likely be converted to an active GCS in the future if the site is subject to regulatory requirements.

If conversion of passive vents to active operation is required, the designer should review the construction of the passive vents to determine what modifications may be required. Passive venting systems are often installed with perforations relatively close to the surface of the landfill, which may need to be modified to prevent air intrusion as discussed previously.

Caisson Wells. Typical vertical extraction wells installed in areas of active filling may need to be periodically extended, or “raised,” with added solid pipe to keep the well over the top of the landfill surface. This allows for continued vacuum to be placed on the waste surrounding the perforated pipe that was originally installed but does not increase the area under vacuum above this zone, as no additional perforated pipe is added.

An alternative approach to the standard drilled vertical extraction well is the caisson or “slip” well (see Figures 7-2 and 7-3). These wells are extended upwards as waste placement continues, but with perforated pipe only. To prevent air infiltration, the perforated well casing is surrounded by a larger diameter “caisson” or slip casing, typically 24 to 36 inch diameter HDPE pipe. This caisson eliminates the use of solid pipe for the well casing and can be pulled upwards through the surrounding waste as lifts are placed. The caisson consists of a blind flange with a wellhead mounted to flexible couplings on top and a pipe bolted to the bottom of the flange that slips over the perforated well casing to prevent air infiltration. As the caisson is advanced in intervals ranging from approximately 10 to 20 feet, the perforated well casing and the backfill stone are also advanced, creating a continuous means of extraction through the waste mass.

The process is similar to that of raising a standard vertical well to accommodate waste placement, although it does require the use of a track hoe or excavator and lifting straps to advance the caisson. Although landfill operators still place waste around this structure in an active disposal area, the large diameter HDPE is significantly more robust than the smaller well casings. This approach allows for earlier extraction of LFG and greater overall LFG recovery during the life of the site.

Figure 7-2. Standard Vertical Well and Caisson Well Extensions



Standard



Caisson

Photos courtesy of Smith Gardner, Inc. and Cornerstone Environmental Group, LLC

Figure 7-3. Typical Caisson Well Detail

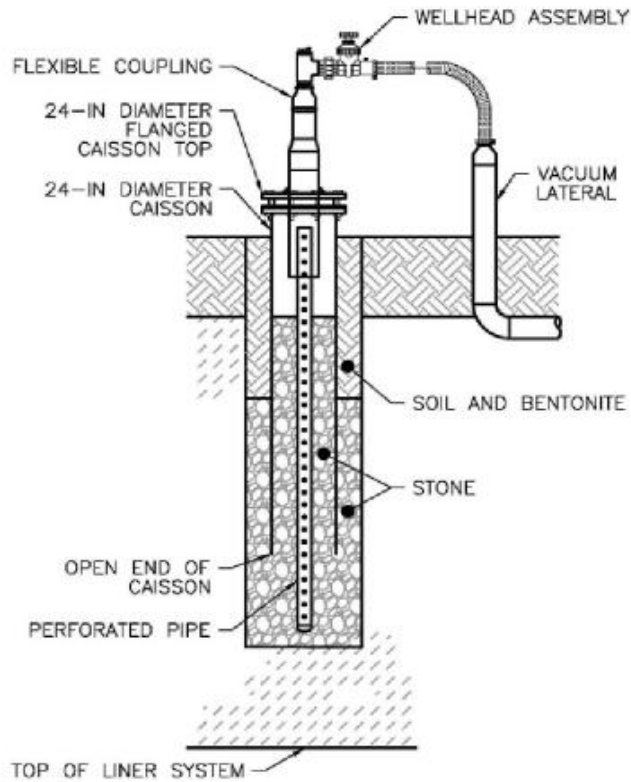

Diagram courtesy of Cornerstone Environmental Group, LLC

Horizontal Collectors

Horizontal collectors are often installed in active areas of the landfill. Horizontal collectors may not disrupt landfill operations as substantially as vertical wells because they are placed at or below the surface of a lift (layer) of waste. In general, horizontal collectors are constructed in the same manner as vertical wells but can be constructed using standard earthmoving equipment instead of using a specialized drill rig. Horizontal collectors are often used as an interim solution to allow LFG collection from a landfill section soon after filling has been completed and possibly while additional filling remains. For horizontal collectors to be effective, adequate waste (up to 30 feet) is required to be placed over them to allow operation without significant air intrusion from the landfill surface. The frequency, length and placement of horizontal collectors is typically selected based upon the goals for installing the collectors such as minimizing offsite migration issues.

Horizontal collectors can be challenging to operate, especially when they are long. It is not unusual for horizontal collectors to be longer than 500 feet. Such horizontal collectors frequently penetrate the landfill cover in two locations to accommodate a wellhead on each end. Even with a wellhead on each end, it may be difficult to control the application of vacuum across the length of the horizontal collector. This can be aided by differing the spacing or diameter of holes along the horizontal collector's length, but this may still not yield even vacuum distribution and uniform LFG extraction.

Trench. An excavated horizontal collector typically involves digging a trench 1.5 to 5 feet deep into the existing waste mass. Due to their horizontal orientation, as well as their placement in more active areas subject to surface water infiltration, horizontal collectors are susceptible to flooding, particularly in wet landfills, unless additional drainage is incorporated into the trench design. The following considerations can mitigate the risk of flooded or blocked horizontal collectors:

- Slope the trench as much as possible to reduce the effects of settlement and allow condensate and other liquids to drain into the waste or out of the casing. A variety of slope designs work, including incorporating a central low spot(s) to which the liquids will drain or bringing the liquid out of the casing by sloping the trench to the exterior slope. If the slope drains toward the exterior of the landfill and the wellhead, the wellhead must be designed to allow liquids to pass around or through the wellhead, so as not to interfere with its operation. Horizontal collectors may follow a sloped working face deck at a uniform depth, to simplify the trench construction.⁶
- Create stone sumps or drains at low points along the trench to allow condensate/liquid drainage. Some designs may connect multiple horizontal collectors together at a central sump that serves to collect drainage.
- Incorporate sufficient depth of gravel backfill in the trench (both below and above the well casing) to promote drainage and good contact with the waste.
- Avoid installation of trenches in low elevations where the waste is saturated.⁷ Assess the landfill leachate system's ability to remove liquid from the waste mass while avoiding the accumulation of liquids in the collector, which can block LFG movement.

⁶ Dean S., Horvath D., Bechtel, J. EarthRes Group, Inc., Horizontal Gas Wells that Last: A Case Study of Performance. March 2012. <http://www.earthres.com/uploads/Horizontal-Gas-Wells-That-Last-A-Case-Study-of-Performance.pdf>.

⁷ British Columbia Ministry of Environment. Landfill Gas Management Facilities Design Guidelines. March 2010. <https://www2.gov.bc.ca/assets/gov/environment/waste-management/garbage/designguidelinesfinal.pdf>.

After the casing is installed, the trench is backfilled with granular material to strengthen the casing and allow the LFG to flow. The same backfill considerations described above for vertical wells apply.

Casing. The type of material and diameter selected for the horizontal collector casing must factor in additional traffic and overburden as well as the overall length of the horizontal collector. HDPE piping is most commonly used in horizontal collectors due to its flexibility. SDR is the ratio of inner diameter to wall thickness and determines HDPE's compression strength (degree of resistance to crushing). The lower the SDR value, the higher the compression strength. A typical SDR value for horizontal collector and header pipe is SDR 17. The diameter of the casing is generally at least six inches to allow for liquid drainage, vacuum distribution and LFG collection.

Due to the typical length of horizontal collectors (exceeding 500 feet in some cases), the perforation size and spacing pattern in the casing should vary to promote more uniform vacuum distribution throughout the length of the collector and maximize gas collection. The ratio of perforations to pipe length should start low closest to the vacuum source and increase as the pipe extends away from the vacuum source. In addition, certain cover types (e.g., synthetic geomembranes) may prevent excess air intrusion and improve the performance of collectors placed near the surface or near exterior slopes. Other alternatives, such as installing supplemental laterals along with the horizontal collectors, may also be employed. Laterals provide additional connection points to the vacuum source (header piping). This option is dictated mainly by the proximity of the header to the horizontal collector at various points along its run. As the horizontal collector forms low points or "bellies" through settlement where liquids may accumulate and block LFG flow, supplemental laterals can provide vacuum on the other side of the blockage.

Considerations for Vertical versus Horizontal Configurations

Factors such as landfill operations, goals of collection and collection schedule determine whether vertical or horizontal wells (or both) are used. Table 7-2 summarizes some general advantages and disadvantages of vertical and horizontal wells. In general, vertical wells have a longer lifespan, functioning for 20 years or more if not affected by operations, liquids accumulation or the accumulation of fines and other materials. Horizontal wells are simpler to install but have shorter useful lifespan due to moisture, settlement and crushing; however, proactive design can prolong the life of horizontal collectors.

Table 7-2. Comparison of Vertical and Horizontal Wells

Vertical Wells		Horizontal Wells	
Advantages	Disadvantages	Advantages	Disadvantages
<ul style="list-style-type: none"> • Effective at controlling LFG within its radius of influence • Adjustable to match LFG generation, allowing effective balancing • Can be installed in active areas if extended or connected to a central manifold 	<ul style="list-style-type: none"> • Misses early LFG collection if installed later in landfill life • Increased operation, maintenance and monitoring if installed in active areas • Periodic re-drills may be required as waste thickness increases or well is affected by liquids 	<ul style="list-style-type: none"> • Often low-cost option for bulk LFG extraction • Allows for early LFG collection • Can be installed by site operators as filling progresses in active areas • No specialized drilling equipment or specialized operators required 	<ul style="list-style-type: none"> • Difficult to adjust due to length, making them difficult to tune • Susceptible to damage or crushing by equipment if not sufficiently protected • Susceptible to flooding if sufficient drainage is not

Vertical Wells		Horizontal Wells	
Advantages	Disadvantages	Advantages	Disadvantages
<ul style="list-style-type: none"> • Most common design and sometimes the preferred (or best understood) design of regulatory agencies • Minimal disruption of landfill operations if placed in inactive areas of the landfill • Reliable and accessible for inspection and maintenance 	<ul style="list-style-type: none"> • and solids accumulation • Requires specialized drilling equipment and crews 	<ul style="list-style-type: none"> • Does not interfere substantially with landfill operations 	<ul style="list-style-type: none"> • incorporated into design • Increased likelihood of air intrusion until sufficiently covered by waste

Design Review

As part of the design process and prior to any construction activities, the location of each extraction well or collector must be evaluated with respect to the existing GCS components and cover and liner systems, to ensure that construction does not adversely affect the disposal area. The designer should commission a survey, by a licensed surveyor, of the actual field elevations at the proposed well locations and compare that elevation to documented liner elevations to determine the allowable depth of drilling or excavation. Similarly, the location of existing header, lateral, compressed air, force main and other utilities should be reviewed to avoid damage during construction.

An experienced contractor or construction manager should complete a constructability review to identify components and connections that may not be practical to construct or operate in the field. They may also identify more cost-effective ways to achieve the goals of the GCS without sacrificing performance.

All elevations should be documented, incorporated into a well construction schedule and reviewed and approved by all parties involved in construction, including the designer, owner, contractor and construction review personnel prior to the commencement of construction. If any well locations change due to field conditions, the process must be repeated.

Although this adds another layer of review and cost to the design process, the extra review is a small price compared to the overall cost of the project and a fraction of potential repair costs associated with liner repairs and regulatory correspondence if the liner system is affected.

Wellheads

A wellhead is installed above the surface of the waste mass to control the vacuum applied to the collector. This regulates the LFG flow rate and composition through the collector. A variety of wellheads styles are available employing different valve and measurement techniques. The type of wellhead selected is typically based on the level of precision required for adjusting the collector.

The wellhead is typically designed with monitoring ports to measure the temperature, pressure (vacuum) and LFG composition (methane, oxygen, nitrogen, carbon dioxide, carbon monoxide and hydrogen sulfide). These ports allow a wellfield technician to record the condition of the collector and the effect of any adjustments and identify and troubleshoot any potential operational issues.⁸ Additional details about interpreting wellhead monitoring data are discussed in [Chapter 8](#).

Wellheads typically include a flow measurement device, usually a pitot tube or orifice plate, which allows a wellfield technician to measure differential pressure across the device and calculate the LFG flow rate. The pressure readings and flow rate data can be used to identify non-producing wells and wells requiring additional investigation. Table 7-3 presents the advantages and disadvantages of using pitot tubes and orifice plates in wellheads.

Table 7-3. Comparison of Wellhead Designs

Pitot Tube		Orifice Plate	
Advantages	Disadvantages	Advantages	Disadvantages
<ul style="list-style-type: none"> Fixed parameters (tube length, meter integration) allow for straightforward set up Easy integration with gas analyzers 	<ul style="list-style-type: none"> Can become fouled and produce inaccurate flow readings Can dislodge from mount and fall into collector High moisture and/or foam can lead to fluctuations while monitoring Limited range of flow 	<ul style="list-style-type: none"> Fixed parameters (tube length, meter integration) allow for straightforward set up Easy integration with gas analyzers Flexible parameters (orifice diameter, wellhead diameter) allow for more accurate tuning and flow measurement Secure mounting point for orifice to prevent the orifice from falling into collector 	<ul style="list-style-type: none"> Smaller diameter plates can hold up condensate in wellhead causing fluctuations Orifice changes must be tracked and updated to maintain flow accuracy If not sized correctly, an orifice plate can limit gas flow

In a traditional vertical well design, the wellhead sits directly on top of the well, however, there may be instances where location of the wellhead is impractical or the placement of the wellhead would cause condensate to collect and impede the flow of LFG. In these instances, a remote wellhead configuration is employed, whereby the wellhead is located a distance from the collector and a small diameter lateral pipe connects the well to the wellhead (see Figure 7-4). In remote configurations, the wellhead should be placed upslope of the well to promote proper drainage of the gas condensate. A remote wellhead configuration may also be better suited for vertical wells in active fill areas, to prevent the potential destruction of the wellhead by the equipment used on the working face.

⁸ U.S. EPA, Global Methane Initiative. International Best Practices Guide for Landfill Gas Energy Projects, Chapter 3: Design, Construction and Operation of Landfill Gas Collection and Control Systems. 2012. http://globalmethane.org/documents/toolsres_lfg_IBPGch3.pdf.

Figure 7-4. Typical Remote Wellhead

Diagram courtesy of Cornerstone Environmental Group, LLC

The connection from a wellhead to the GCS piping should be made with a flexible hose connector—the connection should never be a rigid, hard-piped connection. The GCS piping will settle along with the consolidation of the waste mass, while the wells remain relatively static. This difference in rates of settlement induces stresses on the wellhead and may ultimately break the wellhead itself if a flexible connection is not used.

Several vendors have pre-cut hoses that can be used, or a stock, semi-rigid PVC suction hose can be incorporated into the design. Flexible hoses should be loose, allowing settlement of the GCS without pulling tight, however they should not “drape” or have a low point in the connection that accumulates condensate. Condensate can block vacuum to the well and subsequently block LFG flow to the GCS.

Wellheads are generally connected to the well casing by means of a flexible PVC coupling, secured to both the wellhead and the well casing with worm-gear clamps. This mechanism provides a vacuum tight connection that is relatively easy to install and maintain.

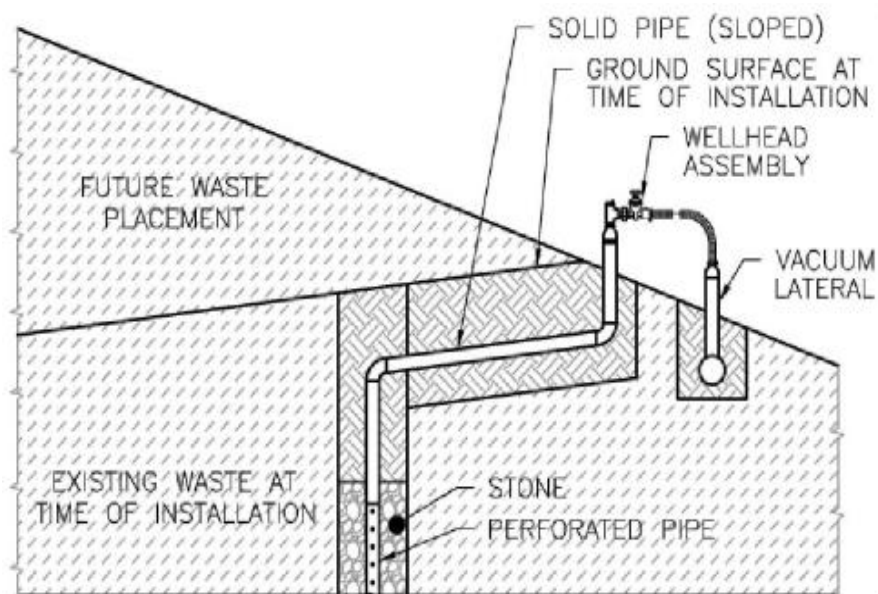
If the operation of the LFG well requires a pump to reduce local waste saturation, an adaptive flange or pre-fabricated well cap that accommodates both LFG and liquids pumping can be utilized. These flanges/caps are available for a range of common LFG well sizes and typically connect to the well casing with clamps or as a bolted flange. They are more rigid than a typical LFG wellhead connection to provide support for the liquids pump operation.

Early/Surface Collection Systems

If LFG is not controlled by a traditional GCS with horizontal and vertical collectors, additional LFG collection elements may be required. These may include shallow surface collectors (in conjunction with interim synthetic covers), collectors at the toe of slopes, collection of gas from leachate collection and removal systems or other similar features. Each of these collectors needs to be individually assessed as to their ability to control the issue for which they are being proposed (e.g., LFG emissions control,

preventing pressure beneath a liner) and their ability to service as a suitable collector for a potential LFG energy project.

The performance of these alternate collectors depends on site-specific factors. Air infiltration is always a concern and may be minimized through cover placement and/or the use of a synthetic cover. Vacuum control is also critical; wellheads with collection valves capable of fine tuning should be used.

7.3 Lateral and Header Piping

To get LFG from the individual collectors to the central processing point, a series of lateral and header pipes is installed around the perimeter and into the interior of the landfill. Typically, the laterals and headers are installed in a phased manner that follows the progression of the development of the landfill with provisions for isolating portions of the system, minimizing head loss and draining condensate. Lateral and header piping should be designed based on site-specific conditions such as expected LFG generation rates, landfill progression plans, obstructions in the landfill, existing systems and other field conditions. Site development and fill progression plans should be assessed to integrate pipe sizes and alignment along with phasing of the installation.

Placement

Landfill geometry, fill progression, development plans, end use plans, collector placement and spacing, waste types, location of landfill feature, settlement rates and provisions for condensate collection are among the factors that should be considered when laying out the system. The GCS layout should use the site topography where possible to achieve the desired slopes. Industry practice is to design the system with multiple pathways for gas flow (i.e., “loops”) in the header piping, providing redundancy for extraction during periods of site development and periodic maintenance or repairs to the header system and to compartmentalize the operations of different sections of the wellfield based upon relative performance of the extraction wells. The header system generally consists of a full loop around the perimeter of the disposal area, with “crossover” headers running between opposing side slopes.

This practice generally allows the use of smaller headers because the flow is distributed between more piping sections and more uniform distribution of vacuum to the extraction points. It also aids in the management of LFG condensate as the flows are more discrete from each section and can be managed more proactively than in a single header.

The layout should have sufficient pipe slope to prevent condensate blockage and ensure drainage to condensate disposal locations. Typical industry practice is to design header piping at a minimum of 4 percent slope in counter-current conditions and 2 percent in concurrent conditions. Headers placed outside the limits of waste may be designed at a lesser slope, depending upon the site conditions. Regardless of the location, the header piping should be designed to utilize the maximum grade practical to reduce the potential impact of future differential settlement.

One major consideration when developing the layout for a GCS is ensuring that excessive waste settlement does not result in low points in the piping network that trap condensate and block the header lines. If feasible, the header piping should follow landfill features such as surface water management berms, roadways and natural topography. This facilitates installation and maintenance of the header lines.⁹ However, allowing interim low points, without the ability to actively drain condensate, is not an

⁹ U.S. Army Corps of Engineers. Landfill Gas Collection and Treatment Systems Engineer Manual. April 2013. http://www.publications.usace.army.mil/Portals/76/Publications/EngineerManuals/EM_200-1-22.pdf?ver=2013-09-05-152155-217.

acceptable design practice. This condition may occur when running header lines over surface water drainage features such as berms and channels or when sudden changes in grade are not considered.

Materials

The GCS piping materials should be selected by considering the field conditions and environmental exposure. As described in Table 7-1, HDPE pipe is generally preferred for laterals and headers because the pipe is flexible over uneven terrain and long distances and can handle differential movement of the waste reasonably well. HDPE also has good resistance to sunlight and the constituents within LFG, allowing its utilization across the landfill surface and in harsh environments. PVC pipe can become brittle in sunlight even within a short period of time and is not preferred for above ground pipe installations. The rigidity of PVC pipe does not allow it to accommodate the differential movement within landfills as well as HDPE, so PVC is not commonly used for header or lateral piping.

HDPE piping has a relatively high modular elasticity related to temperature changes (i.e., the pipe will expand when warmed and shrink when cooled). To prevent degradation of HDPE pipe from sunlight, carbon black is usually mixed with the HDPE resin during manufacture of the pipe, which turns the pipe black, enabling it to absorb more sunlight than a lighter colored pipe. However, this absorption of sunlight results in additional thermal changes in the pipe. Thus, header and lateral piping is often placed in shallow trenches within the landfill to minimize the exposure to sunlight and to restrain the pipe from movement. When installed above ground, HDPE piping should be anchored with pipe guides or soil mounds to direct the piping movement and maintain its alignment, slope and grade.

Size

Piping size should be designed to accommodate the maximum expected LFG flow rates. Isothermal gas flow modeling software can be used to help determine the appropriate pipe size and determine the distribution of vacuum throughout the wellfield. Calculations utilized to model LFG piping systems include, but are not limited to, Darcy-Weisbach, Spitzglass and Mueller. According to the U.S. Army Corps of Engineers,¹⁰ pipes should generally be sized for approximately 1 inch of water column (in. WC) pressure drop per 100 feet of pipe.

Condensate accumulation and removal is another consideration when sizing LFG piping. LFG is usually considered to be saturated with water vapor that condenses inside GCS piping. The condensate generally flows via gravity within the headers and lateral piping to an engineered low point for removal via a pump station or drain. Condensate can accumulate in headers and laterals if there is insufficient slope on the pipe or if settling of the waste results in an unintended low point in the pipe that cannot be drained.

Velocities of LFG in the header piping are typically limited to allow the condensate to flow freely. If the LFG velocity within a pipe becomes too great, it will generate a hydraulic lift of the condensate within the header, forming a temporary obstruction within the pipe. These obstructions can cause the LFG flow to suddenly decrease then increase, creating “surges” in vacuum distribution. If left unchecked these surges result in condensate build-up that prevents the flow of LFG.

Vacuum surges can hamper system performance and may damage mechanical equipment such as the blowers and compressors. Typical industry practice is to limit LFG velocity to no more than 20 feet per second when the LFG flow is counter-current to the condensate flow (LFG is flowing uphill and

¹⁰ U.S. Army Corps of Engineers. Landfill Gas Collection and Treatment Systems Engineer Manual. April 2013. http://www.publications.usace.army.mil/Portals/76/Publications/EngineerManuals/EM_200-1-22.pdf?ver=2013-09-05-152155-217.

condensate is flowing downhill) and the LFG velocity is limited to no more than 40 feet per second when the LFG flow is concurrent to the condensate flow (LFG and condensate are both flowing downhill). Other considerations may need to be given for long runs of pipe without condensate removal devices or sections of pipes anticipated to have abnormally high levels of condensate.

Note that these limitations are guidance only and not regulatorily defined. An assessment of each landfill, including the relative moisture of the LFG and projected rates of differential settlement within the waste mass, should be evaluated as part of the system design process.

7.4 Condensate Management

LFG is usually considered to be saturated with water vapor, and in the process of removing LFG from the collectors, the water vapor condenses out of the gas and forms condensate inside GCS components. The GCS should be designed so this condensate drains to an engineered low point(s) in the header system for removal via a pump station or drain.

A pump station is essentially a sealed wet-well constructed either in-line with the header piping or offset from the header as a separate structure. Condensate drains into the pump station and is periodically pumped, using either electrical or pneumatic pumping components, to a centralized treatment or storage facility. The designer should ensure that an adequate supply of either compressed air (conditioned for the application) or electrical service of the correct voltage and amperage is available for the pump station. Electric and pneumatic pumping systems are both widely used in condensate management applications.

A drain, also known as a trap or drip leg, allows condensate to drain from an evacuated system to an ambient storage vessel such as a tank or lift station, without allowing ambient air intrusion into the GCS. It is very similar to a P-trap used in the drain for a standard sink.

In some instances, condensate is drained back into the waste mass through traps and drainage into rock-filled dissipation features. However, these condensate disposal features can become clogged over time and inhibit condensate drainage into the waste. Traps that drain into the waste often need to be replaced with more permanent condensate removal systems.

Automated or gravity condensate systems that can continuously drain condensate to collection points and convey the condensate to a centralized treatment or disposal point without operator interaction are preferred. These automated systems frequently include electric or pneumatic pumps although other innovative techniques like windmills can be used in limited situations.¹¹

Regardless of the type of condensate management system used, it must be designed for the full range of vacuum application intended for the GCS, possess sufficient throughput volume for the design condensate flow and be capable of maintaining a seal between ambient conditions and the applied GCS vacuum. The designer should estimate the expected condensate generation rate under the typical system vacuum operational range using both mathematical calculations as well as experience with similar systems to ensure sufficient condensate management capacity. Designers typically use natural gas saturation tables or Antoine's Equation to estimate the volume of condensate to be generated within a GCS. The GCS

¹¹ California Integrated Solid Waste Management Board. Technologies and Management Options for Reducing Greenhouse Gas Emissions from Landfills. April 2008. <https://www2.calrecycle.ca.gov/Publications/Details/1268>.

should be designed with an adequate number, size and location of condensate collection points to remove the anticipated condensate from the lateral and header pipes to minimize disruptions to the GCS.¹²

Condensate disposal options should be investigated based on specific conditions at each site, but may include injection into the flare for incineration, disposal within a sanitary sewer or comingling with leachate for disposal.¹³ Factors such as the location of leachate disposal points (e.g., force mains and leachate risers) and availability of compressed air and electrical service helps determine the location and design of condensate management features.

7.5 Blowers and Compressors

Blowers and compressors are critical components of an active GCS because they provide the motive force used to collect LFG from the landfill and push it to the flare or beneficial use equipment. Both devices are designed to apply a vacuum on the GCS. A blower typically delivers a total static pressure of less than 2 pounds-force per square inch gauge (psig) (55 in. WC) whereas, a compressor can be designed to deliver pressures from 5 psig up to hundreds of psig. The device is usually selected based on the GCS design and the end use of the LFG. For flare applications, blowers are typically adequate. However, LFG energy projects like electricity generation, medium-Btu or RNG production typically require higher pressures that could necessitate the use of a compressor.

Sizing and Type

When designing blowers and compressors and their associated piping, the designer should work with a blower manufacturer or specialized LFG skid fabricator to develop equipment specifications based on several considerations, including:

- *Estimated flow rates.* The LFG collection rate must fall within the equipment's operating range. The goal is to provide sufficient capacity and horsepower to efficiently collect the anticipated LFG flow.
- *System vacuum requirements.* Most blowers and compressors can be equipped with a variable frequency drive (VFD), which allows for the vacuum applied to the GCS to be consistently maintained to maximize performance.¹⁴ Establishing a consistent level of vacuum application is critical to achieving and maintaining effective GCS operation.
- *Future development plans.* The equipment should allow for changes in LFG flow rate over time. Often, multiple smaller blowers and compressors are installed in parallel to allow the system to be scaled up or down as the LFG flow rates change and to provide redundancy in the system.
- *Potential end-use requirements.* Destruction or beneficial end uses such as flares, engines or RNG projects have different discharge pressure requirements and may require staged blowers or compressors in series to meet the pressure requirements.
- *Compatible materials.* Materials compatible with LFG and LFG condensate should be used, including protective coatings where applicable. Aluminum components should be avoided because they typically degrade in contact with LFG condensate.

¹² California Integrated Solid Waste Management Board. Technologies and Management Options for Reducing Greenhouse Gas Emissions from Landfills. April 2008. <https://www2.calrecycle.ca.gov/Publications/Details/1268>.

¹³ U.S. Army Corps of Engineers. Landfill Gas Collection and Treatment Systems Engineer Manual, page 3-28. April 2013. http://www.publications.usace.army.mil/Portals/76/Publications/EngineerManuals/EM_200-1-22.pdf?ver=2013-09-05-152155-217.

¹⁴ California Integrated Solid Waste Management Board. Technologies and Management Options for Reducing Greenhouse Gas Emissions from Landfills, page 44. April 2008. <https://www2.calrecycle.ca.gov/Publications/Details/1268>.

- *Power availability.* Small blowers (less than 10 horsepower) can be operated on single phase power. Larger units require three-phase power or the use of phase converters to mimic three-phase. It may be necessary to extend or increase the capacity of the electric service to the project area.

Correct sizing and specifications of the equipment can minimize downtimes during future operations by avoiding flow restrictions or blower surges.¹⁵ Pump and air compressor vendors are a great resource in determining site-specific requirements.

Condensate Management

The effective management of condensate is critical to the successful operation and maintenance of both blowers and compressors. In addition to condensate collection and removal in the lateral and header piping, most manufacturers require a condensate knockout or coalescing filter before the inlet to the blowers or compressors as part of their warranty conditions. Similarly, provisions should be made to drain any condensed liquids from the blower casing. This reduces corrosion of the impellers and internal casing during periods of inactivity as well as potential damage due to freezing in cold climates.

Placement

The design of the equipment should address the existing power supply conditions and capabilities of the local power provider and grid. The equipment should be centrally located relative to the GCS with sufficient space for expansion and oriented to provide fuel to the control device or end use. The mechanical equipment must also be placed to allow ease of access for construction and maintenance personnel, in an area of good drainage and preferably outside the footprint of any projected expansions of the disposal area or other landfill facilities.

7.6 Installation Best Practices

The GCS installation step is often the result of many years of planning. Landfills must obtain multiple permits, including permits to address solid waste, air and water regulations, and prepare detailed construction plans for the landfill and GCS as part of the process. By the time GCS installation begins, detailed written construction plans have been prepared or reviewed by professional engineers. However, because most landfills operate for decades, plans may evolve to meet ongoing site-specific needs.

Construction should employ proven techniques to ensure a well-built system and a construction quality assurance (CQA) program should be implemented to make sure that the system is built following the required design considerations (such as pipe slopes and well depths). Field engineering decisions will need to be made to account for unforeseen conditions at the time of construction. Construction oversight is important to identify potential changes in the system design needed to accommodate site conditions (e.g., changes in the filling pattern, poor waste quality, impermeable areas, discovery of asbestos and inaccessible well locations) and to document the as-built condition of the system.¹⁶

¹⁵ California Integrated Solid Waste Management Board. Technologies and Management Options for Reducing Greenhouse Gas Emissions from Landfills, page 47. April 2008. <https://www2.calrecycle.ca.gov/Publications/Details/1268>.

¹⁶ U.S. EPA, Global Methane Initiative. International Best Practices Guide for Landfill Gas Energy Projects, Chapter 3: Design, Construction and Operation of Landfill Gas Collection and Control Systems. 2012. http://globalmethane.org/documents/toolsres_lfg_IBPGch3.pdf.

Surveying and Documentation

A qualified individual or entity should be identified or hired to provide CQA to monitor and document the techniques used to construct the GCS. The CQA representative generally should be independent from the entity doing the construction work to provide assurances that the work meets necessary requirements and shortcuts are not undertaken. CQA requirements and their implementation vary by state regulatory requirements or by internal company CQA operating procedures. In addition, many GCS engineers and designers will require CQA for their design certification process.

A documented record or survey of as-built components of the GCS is important to ensure landfill operators can pinpoint the location of components in the future to address maintenance issues or expansion of the system. Survey data should also be provided to the design engineer for comparison to the existing construction drawings. Revisions and updates to future constructions may be needed to ensure the system is effective at collecting LFG and is reliable for many years to come.

Many regulatory agencies require CQA documentation and survey of permanent LFG components in the wellfield before issuing an approval letter to commence operation.

Following are several best practices for documenting the construction and installation of a GCS:

- Survey LFG collector locations immediately prior to drilling or installation. A licensed third-party surveyor should complete surveys.
- Update the vertical well drilling schedule with the most recent surface elevation survey data and surveyed liner elevation data from the base liner CQA report(s). The well schedule must be approved by the LFG system design engineer, as well as the landfill's representatives, CQA staff and drilling personnel prior to installation.
- Survey relocated collectors and obtain approval of the updated well schedule, prior to installation.
- Document vertical borehole conditions during drilling, including waste type, stage of decomposition, temperature and moisture.
- Prior to the contractor beginning any vertical drilling or installation, the designated CQA monitor should verify the elevation and depth of the collector based on the existing or as-built construction drawings to avoid drilling through the landfill liner.
- Survey as-built conditions of all new LFG system components, including collectors, laterals and headers. Survey data should include at a minimum the horizontal and vertical location of all installed system components every 100 feet, all directional changes, piping size transitions, valves, condensate sumps and traps and special assemblies.
- Document the as-built conditions in a CQA Report, including a Record Construction Drawing defining the actual extent of construction, photographic logs of construction activities, daily CQA reports and any testing documentation (e.g., pipe pressure testing, soils and geosynthetics testing).

Wells installed in active fill areas should be clearly marked with bright colored cones or flagging to minimize the risk of damage by compaction equipment. In addition, effectively training and coordinating the installation with all staff who work on the active areas will help minimize damage. Even when incorporating operator training, given the challenges of installing and extending wells in an active filling zone, landfill owners/operators should plan for a higher rate of repairs and/or replacement wells in active areas.