

---

# Developing Reasonable Assurance: A Guide to Performing Model-Based Analysis to Support Municipal Stormwater Program Planning

---

## Appendices



## A. EXAMPLE EMERGING MS4 PERMITS AND RAA REQUIREMENTS

The following sections provide a summary of select MS4 permits throughout the U.S. with varying requirements for RAAs, including case studies of RAAs performed to address these requirements (Table A-1).

**Table A-1. Appendix A Example MS4 Permits**

Section	MS4 Permit	RAA Approach	Case Study Included
A.1	Los Angeles County Phase I MS4 Permit	Deterministic	a. Upper Los Angeles River EWMP b. Santa Monica Bay Jurisdictional Group 2 and 3 EWMP
A.2	Washington Phase I MS4 Permit	Deterministic	Stormwater Retrofit Plan for WRIA 9, King County, WA
A.3	San Diego Region Phase I MS4 Permit	Deterministic	Los Peñasquitos Watershed Management Area WQIP and CLRP
A.4	Central Coast California Phase I and Phase II MS4 Permit	Deterministic	City of Pacific Grove and City of Monterey; ASBS Low Impact Development Planning and Future Implementation
A.5	San Francisco Bay Area Regional MS4 Permit	Deterministic	Tools are described, pilot implementation is underway.
A.6	Virginia Phase I MS4 Permits Addressing the Chesapeake Bay TMDL	Prescriptive	Arlington County Chesapeake Bay TMDL Action Plan
A.7	Massachusetts General Phase II MS4 Permits	Prescriptive	Optimal Stormwater Management Plan Alternatives: A Demonstration Project in Three Upper Charles River Communities

## A.1 Los Angeles County Phase I MS4 Permit

---

Administered by the Los Angeles Regional Water Quality Control Board (LARWQCB), NPDES Permit No. CAS004001 sets requirements for MS4 discharges of stormwater and non-stormwater by Los Angeles County Flood Control District (LACFCD), the County of Los Angeles, and 84 cities within coastal watersheds of Los Angeles County (hereafter referred to as the Los Angeles County MS4 Permit). This permit covers more than 3,000 square miles of area within Los Angeles County, including multiple watersheds that each have distinct hydrologic characteristics, beneficial uses, and water quality impairments (LARWQCB 2012).

The Los Angeles County MS4 Permit incorporates WQBELs to implement wasteload allocations for 33 TMDLs that address a range of pollutants, including metals, bacteria, toxic pollutants (e.g., PCBs, DDT), nutrients, chloride, sediment, and trash. These TMDL wasteload allocations and associated assumptions and requirements are established as WQBELs in the permit, which are assigned to those permittees that discharge to the waterbodies addressed by the TMDL. To demonstrate compliance with WQBELs and receiving water limitations, a permittee has the option to participate in a Watershed Management Program<sup>1</sup> (individually or through collaboration with other permittees) to identify control measures and BMPs to be implemented over time to meet those WQBELs and receiving water limitations. A key component of the Watershed Management Programs is the RAA, for which the permit defines as follows:

“Permittees shall conduct a Reasonable Assurance Analysis for each water body-pollutant combination addressed by the Watershed Management Program. A Reasonable Assurance Analysis (RAA) shall be quantitative and performed using a peer-reviewed model in the public domain. Models to be considered for the RAA, without exclusion, are the Watershed Management Modeling System (WMMS), Hydrologic Simulation Program - FORTRAN (HSPF), and the Structural BMP Prioritization and Analysis Tool (SBPAT). The RAA shall commence with assembly of all available, relevant subwatershed data collected within the last 10 years, including land use and pollutant loading data, establishment of quality assurance/quality control (QA/QC) criteria, QA/QC checks of the data, and identification of the data set meeting the criteria for use in the analysis. Data on performance of watershed control measures needed as model input shall be drawn only from peer-reviewed sources. These data shall be statistically analyzed to determine the best estimate of performance and the confidence limits on that estimate for the pollutants to be evaluated. The objective of the RAA shall be to demonstrate the ability of Watershed Management Programs and EWMPs to ensure that Permittees’ MS4 discharges achieve applicable water quality based effluent limitations and do not cause or contribute to exceedances of receiving water limitations.”

Prior to adoption of the Los Angeles County Permit, there had been a number of public domain models developed in the region that supported TMDL source assessments and/or the calculation of wasteload allocations or were specifically designed to support TMDL implementation and watershed planning efforts. These models had been developed through a public process, underwent public and peer reviews, and were publicly available at no cost. The availability and general acceptance of these modeling systems contributed to the ability of permittees to perform cost-

---

<sup>1</sup> Permittees may also elect to develop an Enhanced Watershed Management Program (EWMP), which are consistent with Watershed Management Programs but include an evaluation of opportunities for collaboration among permittees and other partners on multi-benefit regional projects.

effective RAAs to meet permit requirements, as well as aid review of models used to support RAAs by the permitting authority. Below is a summary of the models referenced in the permit that are available to support RAAs.

- **Hydrologic Simulation Program – FORTRAN (HSPF)** (Bicknell et al. 1997) and the Loading Simulation Program C++ (LSPC), a recoded version of HSPF into C++ (Shen et al. 2004; Tetra Tech and USEPA 2002; USEPA 2003), were used by the LARWQCB and EPA to model various watersheds throughout the region to support the development of TMDLs. The models typically supported the source assessment, linkage analysis, and/or calculation of load and wasteload allocations for the TMDLs (LARWQCB 2002, 2006, and 2010; LARWQCB and USEPA 2005a, 2005b, and 2011).
- **Watershed Management Modeling System (WMMS)** was developed by the LACFCD to support the management of stormwater and improvement of water quality throughout coastal watersheds of Los Angeles County. WMMS is a public domain platform that includes a combination of two models: (1) LSPC for dynamic simulation of watershed flows and pollutant concentrations, and (2) EPA's System for Urban Stormwater Treatment and Analysis IntegratiON (SUSTAIN) for simulation of BMP processes and optimization and selection of cost-effective combinations of BMPs to support stormwater management (LACDPW 2010a, 2010b, and 2011; USEPA 2009).
- **Structural BMP Prioritization and Analysis Tool (SBPAT)** is a public domain, GIS-based water quality analysis tool to support the prioritization and selection of BMP project opportunities in watersheds, including the quantification of the benefits, costs, uncertainties, and potential risks. SPBAT is a modeling system that utilizes land use event mean concentrations, EPA-SWMM, data from the EPA/American Society of Civil Engineers International BMP Database, and a Monte Carlo approach to quantify water quality benefits and uncertainties (Geosyntec Consultants 2008 and 2012).

To further assist permittee efforts to perform RAAs in the region, the LARWQCB (2014) prepared a guidance document to provide information and guidelines for RAAs, additional clarification of permit requirements regarding the RAA, and recommended criteria for permittees to follow in preparing an appropriate RAA for LARWQCB approval. This guidance specifically addressed processes for:

1. Identification of water quality priorities to achieved applicable water quality limitations (e.g., WQBELs and receiving water limitations);
2. Assessment of current/existing pollutant loading associated with current BMPs;
3. Estimation of required pollutant reductions to meet interim and/or final allowable pollutant loadings;
4. Selection of strategies, control measures, and BMPs to be implemented to attain needed reductions;
5. Specification of a schedule of selected watershed management strategies that are sufficient to result in attainment of corresponding interim and/or final pollutant reductions;
6. Development of a pollutant reduction plan, including:
  - a. Determination of compliance points to assess MS4 discharges from the area covered by a Watershed Management Program to the receiving waters;
  - b. Evaluation of selected management program/BMP performance;
  - c. Analysis to demonstrate that the selected BMPs cumulatively have reasonable assurance to meet interim/final requirements;
  - d. Process for incorporating additional BMPs if water quality milestones are not met as scheduled.

The guidance also provided specific modeling requirements for performing RAAs to support estimation of current loadings, required load reductions, and analysis of water quality outcomes of selected BMP options. Within this discussion, the LARWQCB provided a general description of available models, expectations in terms of model input and output to be reported for the RAA, critical conditions to be represented by the model for pollutant reduction analyses (90<sup>th</sup> percentile flow rates and/or the critical conditions specified in applicable TMDLs), and model calibration criteria.

The LARWQCB guidance for RAAs is a detailed approach specific to the Los Angeles County Permit. Development of the guidance was a collaborative effort of permittees, as the LARWQCB provided generous opportunity for input from permittees on discussions and assumptions included in the guidance. Much of the discussions within the guidance are meant to provide clarification of requirements within that permit. Modeling requirements that were documented in the guidance are meant for experienced modelers, as many of the specifics discussed dealt directly with model input, output, and statistical approaches for assessing model performance and acceptability of calibration. However, there are multiple lessons learned from the availability and application of guidance with the technical specificity provided by the LARWQCB, including the following:

- **Information for selection of RAA approaches:** Permittees may not have modeling capability, and all Los Angeles area permittees that chose to follow this compliance pathway utilized contractors to develop and perform RAAs for the various Watershed Management Programs. This required the permittees to develop scopes of work, issue Requests for Proposals, review contractor proposals, and select among qualified contractors and proposed technical approaches to performing an RAA. The LARWQCB guidance “set the bar” in terms of the expectation of the RAA, and provided sufficient information to permittees to guide the selection of RAA technical approaches and contractors.
- **Recommended instructions for performing RAAs:** With explicit instructions on the permit expectations and process to be followed in performing RAAs, permittees were provided a clear roadmap and understanding of the tasks to be completed.
- **Clear expectations of LARWQCB to guide approval of RAAs:** The guidance provided permittees a clear understanding of LARWQCB expectations of the RAA and the documentation needed to accompany the Watershed Management Program. As long as a permittee followed the guidance, it was provided additional assurance that the LARWQCB would approve the RAA. Although LARWQCB often provided comments and/or requested additional information or documentation during its review of draft RAAs, it was generally found that the guidance served as an important reference throughout the review process and was a clear indicator of LARWQCB preferences to ensure RAA approval.

Thirty-one Watershed Management Programs and associated RAAs were completed to meet requirements of the Los Angeles County MS4 Permit and the LARWQCB guidance on RAAs. These Watershed Management Programs were developed by groups of permittees and individual permittees, and varied significantly depending on the watershed’s water quality priorities, preferences of the permittees, types of BMPs proposed, and a number of additional factors. The following provides summaries of RAAs to support Watershed Management Programs for the Upper Los Angeles River (ULAR WMG 2016) and a group of jurisdictions discharging to Santa Monica Bay (SMB JG2/JG3 EWMP Group 2016), which varied in terms of models selected to support RAAs and the pollutants that were addressed.

## Upper Los Angeles River EWMP

An EWMP for the Upper Los Angeles River (ULAR) Watershed Management Area (ULAR EWMP Area) was developed by the cities of Los Angeles, Alhambra, Burbank, Calabasas, Glendale, Hidden Hills, La Cañada Flintridge, Montebello, Monterey Park, Pasadena, Rosemead, San Fernando, Los Angeles, San Marino, South Pasadena, and Temple City and the County of Los Angeles/LACFCO. The planning area for the ULAR EWMP is the largest of all the EWMPs in the Los Angeles region, representing 479 square miles of watershed. The LSPC and SUSTAIN components of WMMS served as the basis for the modeling system used to conduct the RAA for the ULAR EWMP (ULAR WMG 2016).

**Element 1:** The RAA addressed areas identified through discussions with the LARWQCB to be regulated by the Los Angeles County MS4 Permit. This excluded areas addressed by separate NPDES permits (e.g., Caltrans, Industrial General Permit) and federal and state owned lands (e.g., CA Dept. of Fish and Wildlife).

**Element 2:** The LSPC model of the LA River watershed (available within WMMS) was used to characterize existing hydrologic and pollutant loading conditions within the watershed. The model provided hourly simulation of flow and sediment/pollutant concentrations from 1,129 model subwatersheds. This included modeling of Assessment Areas within and outside of the EWMP area to allow calibration of the model based on monitoring data collected throughout the watershed (Figure A-1). Model subwatersheds were also configured to provide separation of municipal jurisdictions to allow characterization of stormwater pollutant loadings from each jurisdiction. The model was calibrated to meet criteria established by the LARWQCB guidelines, with results of calibration (Figure A-2 and Table A-2) and characterization of existing pollutant loads documented within the EWMP. A separate methodology was used to characterize existing non-stormwater, which typically results from outdoor water use during dry weather conditions. The amount of non-stormwater generated in each ULAR subwatershed was estimated as the product of (1) the estimated population based on U.S. census blocks and (2) the estimated per capita outdoor water use.

**Element 3:** As part of the overall EWMP planning effort, water quality priorities were established based on WQBELs and receiving water limitations relevant to each of the Assessment Areas (Figure A-1). The LARWQCB guidelines allow the RAA to be developed with consideration of a “limiting pollutant”, or the pollutant that drives BMP implementation planning (i.e., control measures that address the limiting pollutant will also address other pollutants). Limiting pollutants were identified in the RAA as zinc and *E. coli* during wet weather, and *E. coli* during dry weather. Based on a critical wet weather condition defined by the RAA guidelines (90th percentile flow), the LSPC model was used to compare predictions of existing water quality with numeric targets to determine necessary reductions to attain WQBELs and receiving water limitations (Figure A-3). For dry weather, the goal of the EWMP was 100% reduction of non-stormwater, which was quantified during critical drought conditions from late August to September.

**Element 4:** The EWMP planning efforts identified a number of opportunities for BMPs to be implemented within each municipal jurisdiction. These included nonstructural programs and structural BMPs, including low impact development (LID) (e.g., LID ordinance for new and re-development, retrofits of public parcels), green streets, and regional projects that provide centralized treatment of large drainage areas. The RAA provided (1) demonstration that pollutant reduction targets will be achieved with BMPs implemented within each jurisdiction (Figure A-3), and (2) cost-benefit analysis of various BMP scenarios to identify the most cost-effective implementation plan. Based on discussions with the LARWQCB, nonstructural programs were assumed to achieve a 5% or 10% pollutant reduction depending on the amount/types of programs to be implemented within each jurisdiction. For structural BMPs, the RAA provided simulation of stormwater and non-stormwater flows to the BMPs, and SUSTAIN provided analysis of the volumes reduced to meet pollutant reduction goals. SUSTAIN also provided cost-optimization of millions of BMP scenarios to identify the most cost effective combination of BMPs to meet interim and final schedule milestones (Figure A-4).

**Element 5:** Results of the RAA were reported in detail using maps, charts, and tables that present for each jurisdiction the volumes of stormwater to be managed in each subwatershed (Compliance Targets) and the control measures to achieve those volume reductions (EWMP Implementation Strategy) to meet interim and final schedule milestones. The resulting Compliance Targets provide a mechanism for tracking and reporting of progress implementing the EWMP. The EWMP Implementation Strategy provides a framework for adaptive management and development of more detailed capital improvement planning efforts in the future.

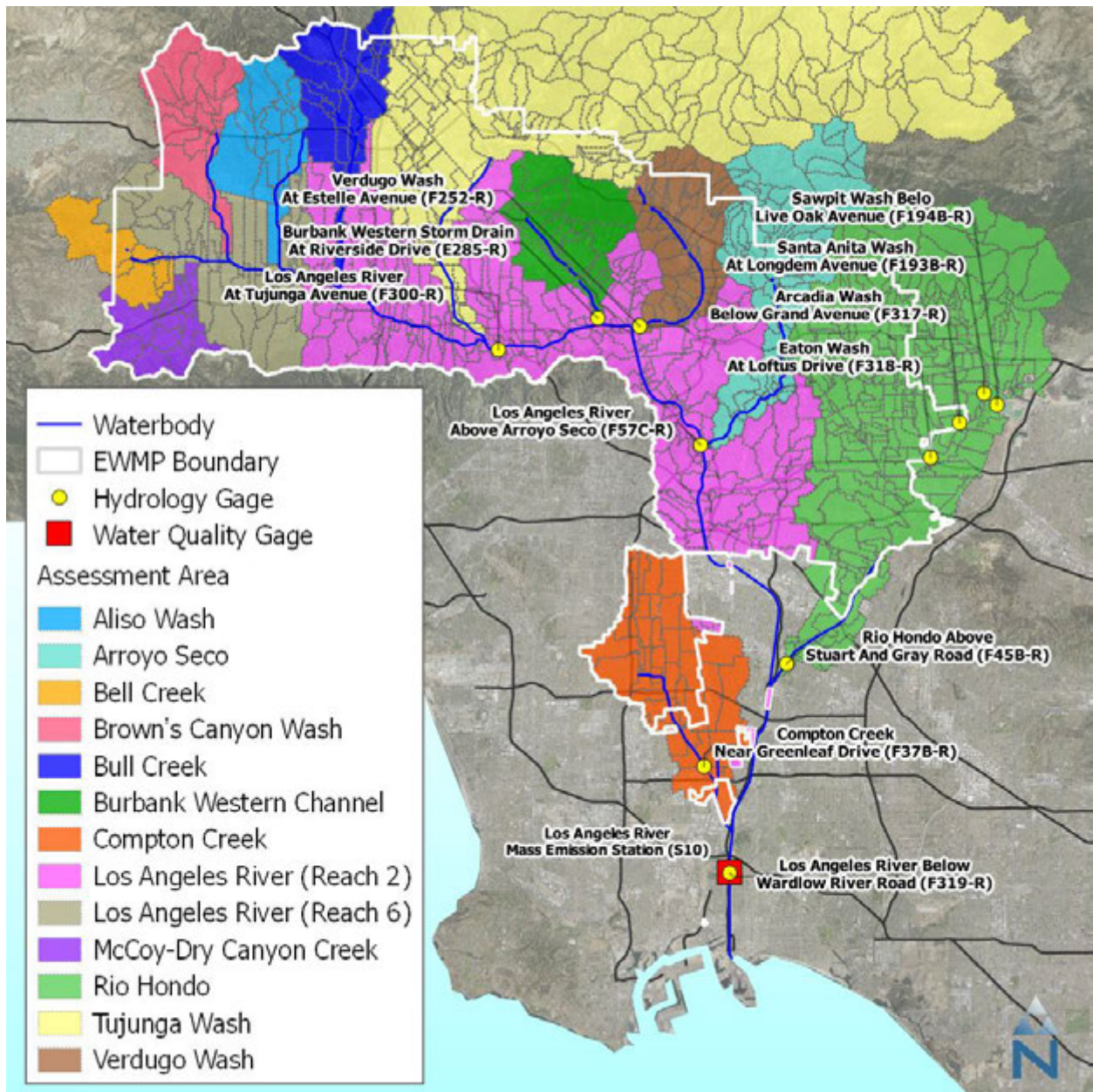

Figure A-1. ULAR EWMP Area, Model Subwatersheds, and Monitoring Stations (ULAR WMG 2016).



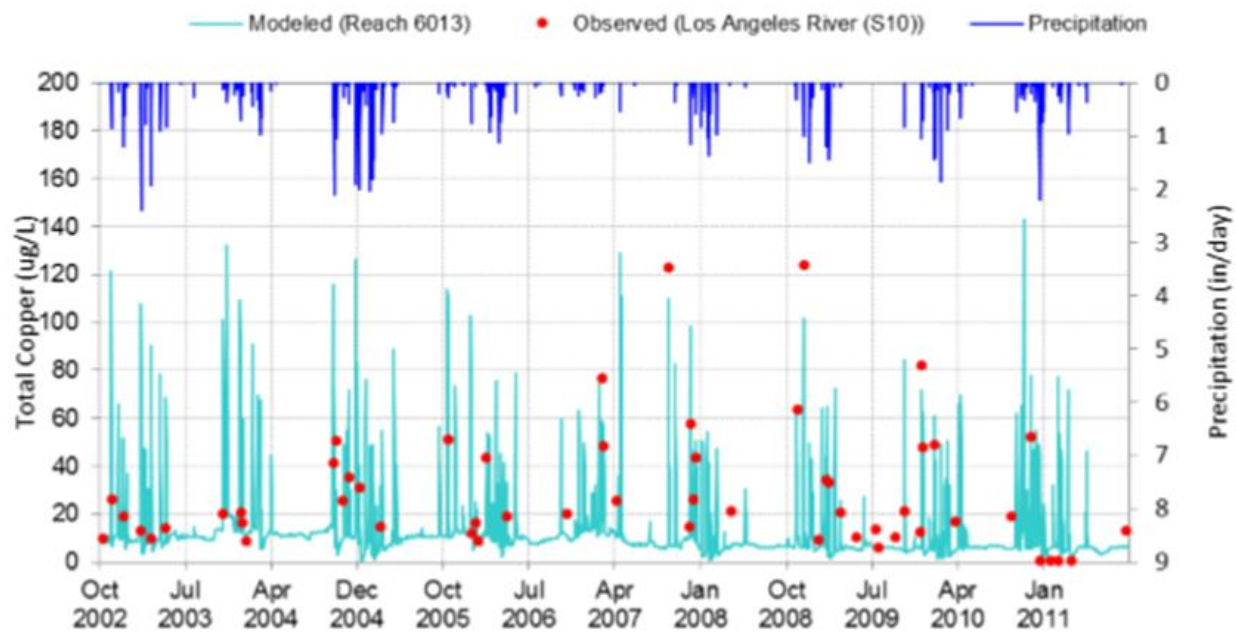

Figure A-2. Model Water Quality (total copper) Calibration for Los Angeles River (ULAR WMG 2016).

Table A-2. Summary of Water Quality Calibration Performance for the Upper Los Angeles River Watershed (ULAR WMG 2016).

Water Quality Constituent	Sample Count	Model vs. Observed Load (% Error)	Los Angeles RAA Guidelines Performance Assessment
Total Sediment	80	8.6%	Very Good
Total Copper	54	-20.1%	Good
Total Zinc	54	-27.7%	Fair
Total Lead	49	-32.5%	Fair
E. Coli <sup>1</sup>	49	-32.1%	Fair
Total Phosphorus	49	-13.1%	Very Good

<sup>1</sup> *E. coli* was assumed to have a 1:1 translator with fecal coliform.

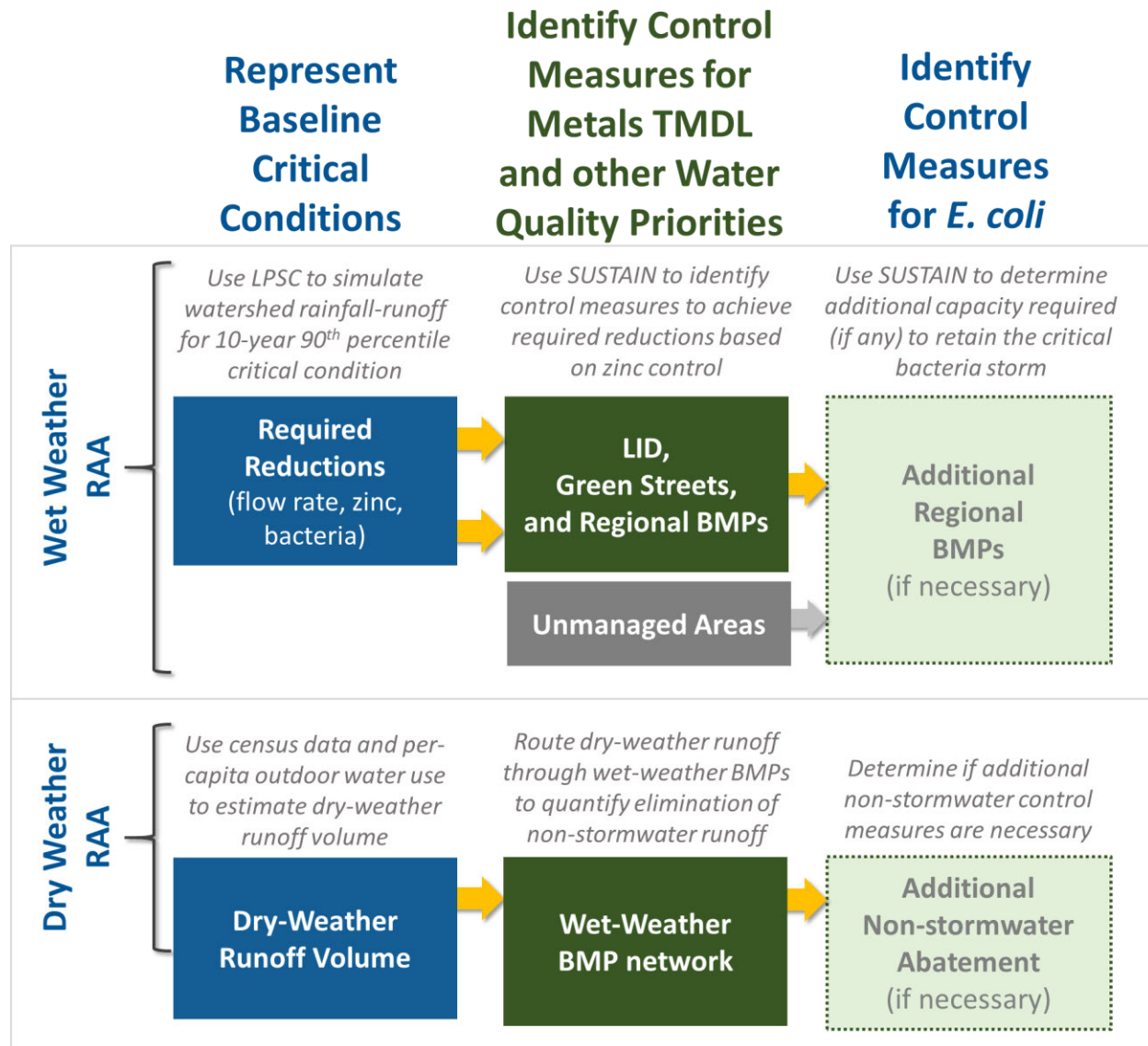
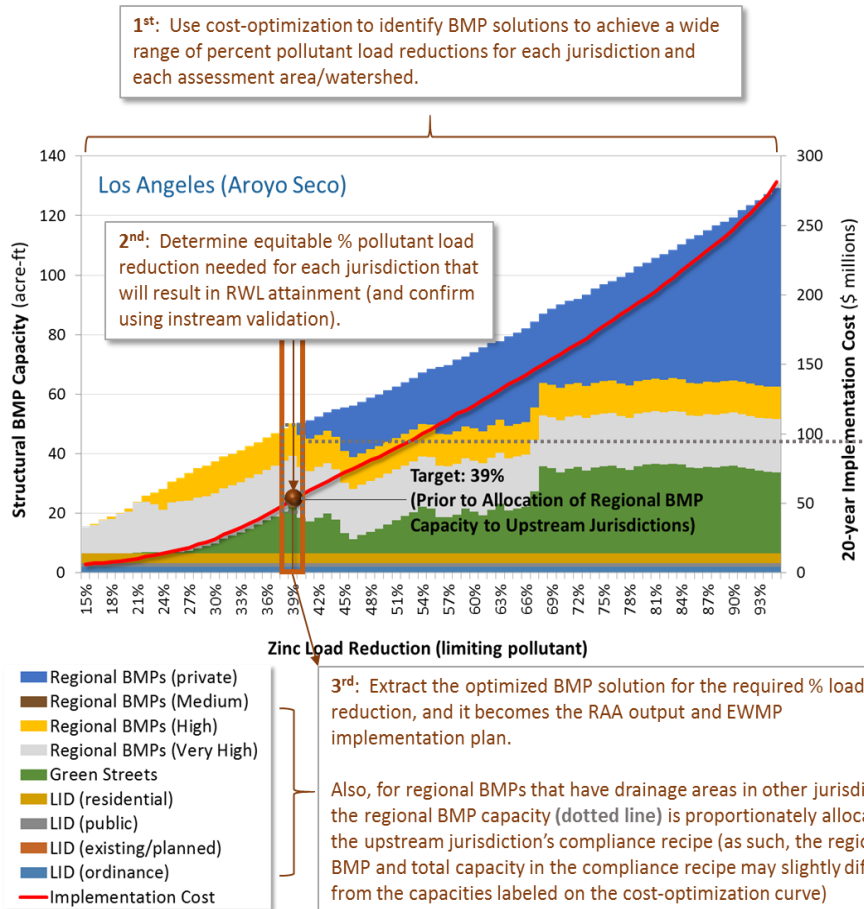

Figure A-3. RAA Process used by the ULAR EWMP to Establish Critical Conditions and Address Water Quality Priorities (ULAR WMG 2016).



**COMPLIANCE TARGETS: MEASURABLE AND ENFORCEABLE BMP GOAL**

**EWMP IMPLEMENTATION PLAN: APPROACH TO ACHIEVE COMPLIANCE TARGETS, SUBJECT TO ADAPTIVE MANAGEMENT (BMP capacity expressed in units of acre-feet)**

Subwatershed ID	For Metals		% Load Reduction Critical Condition	For Metals Attainment by 2028							For Bacteria Attainment by 2037				
	24-hour Volume Retained (acre-ft)	Additional 24-hour Volume to be Retained (acre-ft)		Low-Impact Development			Streets		Regional BMPs			Total BMP Capacity (acre-ft)	Regional BMPs (private) (acre-ft)	Total BMP Capacity (acre-ft)	
				Ordinance	Planned LID	Public LID	Residential LID	Green Streets	Very High (public, owned)	High (public, owned)	Medium (public, non-owned)				Private
640249	22.20	0.62	48%	0.50	—	0.15	0.78	3.36	2.99	0.00	0.00	0.00	7.8	0.62	8.4
640349	0.14	0.20	7%	0.14	—	—	0.00	0.00	0.00	0.00	0.00	0.00	0.1	0.20	0.3
640449	0.13	0.05	12%	0.03	—	0.08	0.01	0.00	0.00	0.00	0.00	0.00	0.1	0.05	0.2
640549	1.98	0.23	9%	0.54	0.02	—	1.37	0.00	13.22	0.04	0.00	0.00	15.2	0.23	15.4
640649	5.29	0.08	38%	0.20	—	—	0.15	4.45	0.00	0.00	0.00	0.00	4.8	0.08	4.9
640749	6.01	0.07	47%	0.22	0.00	0.24	0.22	2.89	0.00	3.21	0.00	0.00	6.8	0.07	6.9
640849	12.22	0.01	63%	0.23	—	0.35	0.54	2.98	0.00	4.82	0.00	0.00	8.9	0.01	8.9
640949	1.40	0.02	37%	0.06	—	0.22	0.01	0.43	0.00	0.10	0.00	0.00	0.8	0.02	0.8
641049	1.94	0.01	48%	0.05	—	—	0.08	1.63	0.01	0.42	0.00	0.00	2.2	0.01	2.2
641149	0.90	0.00	48%	0.02	—	0.02	0.04	0.69	0.06	0.00	0.00	0.00	0.8	0.00	0.8
641449	0.02	0.00	64%	0.00	—	0.02	0.00	0.00	0.00	0.02	0.00	0.00	0.0	0.00	0.0
641549	1.13	0.01	49%	0.03	—	0.11	0.11	0.00	0.65	0.00	0.00	0.00	0.9	0.01	0.9
641649	0.00	0.00	13%	0.00	—	0.00	0.00	0.00	0.00	0.00	0.00	0.00	0.0	0.00	0.0
642049	0.00	0.00	6%	0.00	—	—	—	0.00	0.00	0.00	0.00	0.00	0.0	0.00	0.0
<b>Total</b>	<b>53.4</b>	<b>1.3</b>	<b>39%</b>	<b>2.0</b>	<b>0.0</b>	<b>1.2</b>	<b>3.3</b>	<b>16.4</b>	<b>16.9</b>	<b>8.6</b>	<b>0.0</b>	<b>0.0</b>	<b>48.6</b>	<b>1.3</b>	<b>49.9</b>

RED = Subwatersheds with highest required % load reductions  
 BLUE = Subwatersheds with highest BMP capacities within a BMP category

Figure A-4. Illustration of how the EWMP Implementation Strategy is Extracted from a Cost Optimization Curve (ULAR WMG 2016).<sup>2</sup>

<sup>2</sup> This illustration uses the City of Los Angeles jurisdiction in the Arroyo Seco watershed as an example. Three steps are shown for RAA development: cost-optimized BMP solutions are developed for a wide range of % load reductions (1<sup>st</sup>, uppermost text box), followed by determination of the equitable % load reduction needed to attain RWLs for the corresponding receiving water (2<sup>nd</sup>, middle text box), and then the corresponding BMP solution is extracted to complete the RAA and determine the EWMP Implementation Strategy for the jurisdictional area (3<sup>rd</sup>, bottom text box). The EWMP Implementation Strategy for each jurisdiction and assessment area is presented separately in the EWMP. Note that while all jurisdictions in an assessment area/watershed are held to an equivalent % reduction, subwatersheds *within* a jurisdiction may have variable reductions based on optimization (which is why some subwatersheds have high % reductions [red shaded rows in table] and others have low % reductions).

## **Santa Monica Bay Jurisdictional Group 2 and 3 EWMP**

The Santa Monica Bay (SMB) Jurisdictional Groups 2 and 3 (JG2/JG3) EWMP was developed by the cities of Los Angeles, Santa Monica, El Segundo, and the County of Los Angeles/LACFCO. The JG2/JG3 planning area for the SMB EWMP covered 39.4 square miles within central region of the SMB watershed, including the urbanized Dockweiler and Santa Monica subwatersheds, as well as natural open space located in the Castle Rock, Pulga Canyon, Temescal Canyon, and Santa Monica Canyon subwatersheds (SMB EWMP Area). The RAA of the SMB EWMP was based on the SBPAT modeling system (SMB JG2/JG3 EWMP Group 2016).

**Element 1:** Through discussions with the LARWQCB, the EWMP addressed areas regulated by the Los Angeles County MS4 Permit, excluding federal and state owned lands or areas regulated by other NPDES permits (e.g., Caltrans, Industrial General Permit) ( ).

**Element 2:** SBPAT was used to characterize existing hydrologic and pollutant loading conditions in the watershed. SBPAT utilized EPA's Stormwater Management Model (SWMM) to simulate stormwater runoff. SBPAT linked long-term hydrologic output from SWMM to a stochastic Monte Carlo water quality model to develop statistical descriptions of stormwater quantity and quality. This approach combines model-predicted stormwater runoff volumes with land-use based event mean concentrations (EMCs) through a statistical process to predict existing wet weather pollutant loads. The RAA did not include a quantification of existing non-stormwater flows or pollutant loads during dry weather. Instead, the EWMP relied on a semi-quantitative approach to address dry weather that focused on implementation and further monitoring.

**Element 3:** Parallel to the RAA, EWMP planning efforts established water quality priorities based on WQBELs and receiving water limitations to address multiple TMDLs and 303(d) impairments for SMB (DDT, PCBs, debris), adjacent beaches (bacteria), and the Santa Monica Canyon Channel (bacteria and lead). The RAA for debris was based on demonstration that a number of catch basins will be retrofitted with screens or inserts to capture debris. Of the water quality priorities identified, only lead and bacteria were determined to be caused or contributed by MS4 dischargers, requiring an RAA. Based on a critical condition established by the RAA guidelines, the SBPAT model was used to compare the existing load (90<sup>th</sup> percentile flow and concentration) with the target load (90<sup>th</sup> percentile flow and target concentration) for lead to determine load reduction goals for wet weather. However, as the target concentration exceeded the critical concentration, no reduction of lead was determined necessary to address the water quality priority. To address wet weather bacteria, SBPAT was used to compare existing and target flows and concentrations during the critical condition to determine wet weather load reductions. To address bacteria during dry weather, the RAA assumed 100% capture or treatment of non-stormwater discharging from MS4 outfalls that cause or contribute to the exceedance of water quality objectives for SMB beaches.

**Element 4:** The EWMP identified multiple opportunities for nonstructural and structural BMPs within each municipal jurisdiction. The RAA included a process for prioritizing BMPs based on cost, effectiveness, and feasibility for implementation. Nonstructural BMPs were given highest priority, and addressed in the RAA based on two methods: (1) a pollutant load reduction of 2.5% to 7.5% was assumed for BMPs that were not modeled, and (2) SBPAT was used to simulate load reductions associated with public BMP retrofit incentives (e.g., downspout disconnects) and LID associated with redevelopment. SBPAT was also used to estimate load reductions associated with a number of green streets, assuming these BMPs were designed to capture 100% of the 85<sup>th</sup> percentile, 24-hour storm. The RAA included representation of existing, planned, and proposed regional/centralized BMPs, with SBPAT modeling the BMPs as closely as possible to their actual or conceptual designs. Figure A-6 provides a summary of the methods used by SBPAT to represent structural BMPs. No modeling was performed in the RAA to demonstrate dry weather pollutant reductions, rather, BMPs associated with the diversion, infiltration, or disinfection of non-stormwater was assumed to completely address pollutant reduction goals.

**Element 5:** Results of the RAA were reported in tables, charts, and maps that presented the % load reduction, stormwater volumes to be managed, and capacities of structural BMPs for each BMP type, model subwatershed, and jurisdiction to meet interim and final schedule milestones. The results of the RAA provided measurable and quantifiable metrics (e.g., stormwater volumes managed) for future tracking of the progress of BMP implementation based on adaptive management.

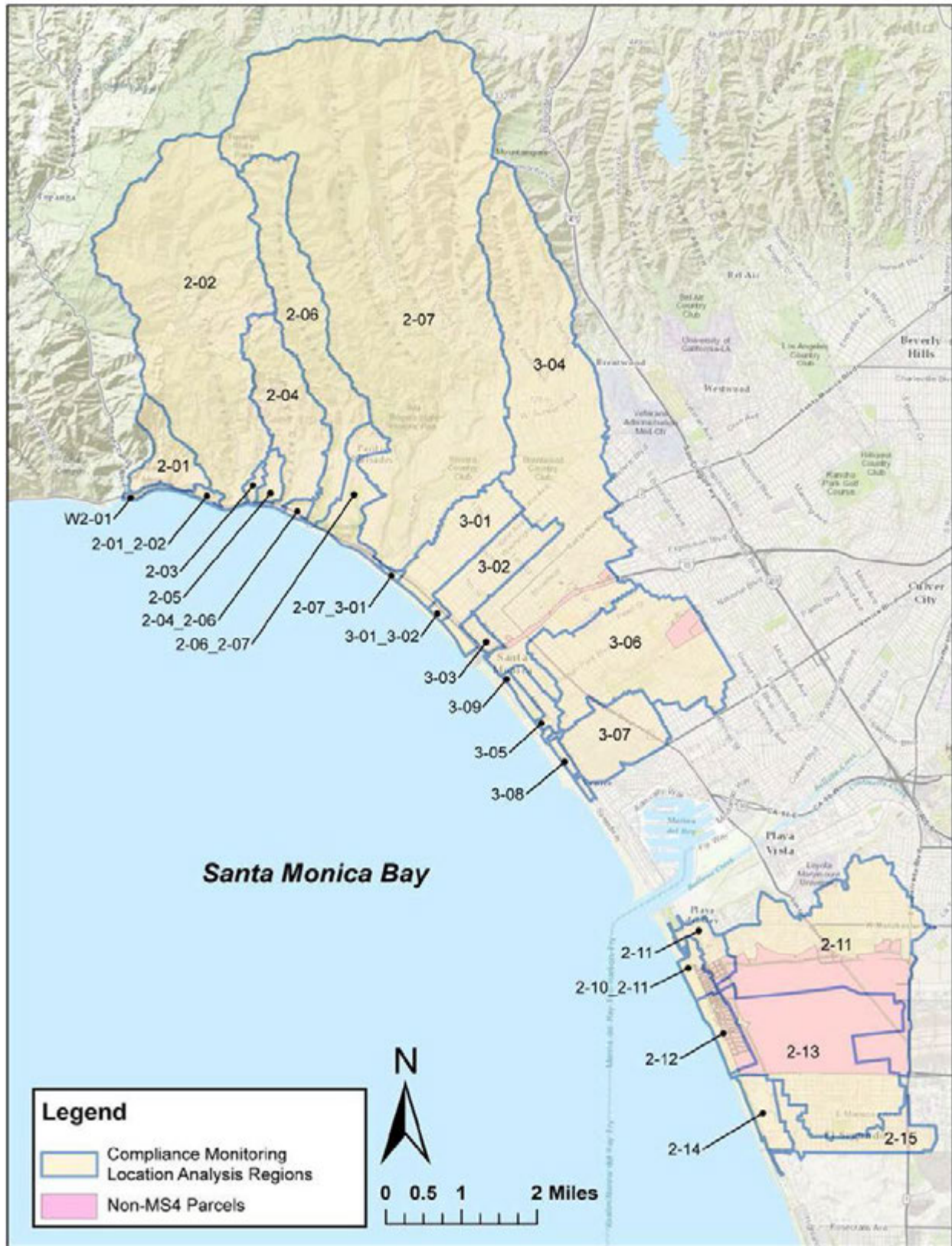

Figure A-5. SMB EWMP Area and Model Subwatersheds (SMB JG2/JG3 EWMP Group 2016).

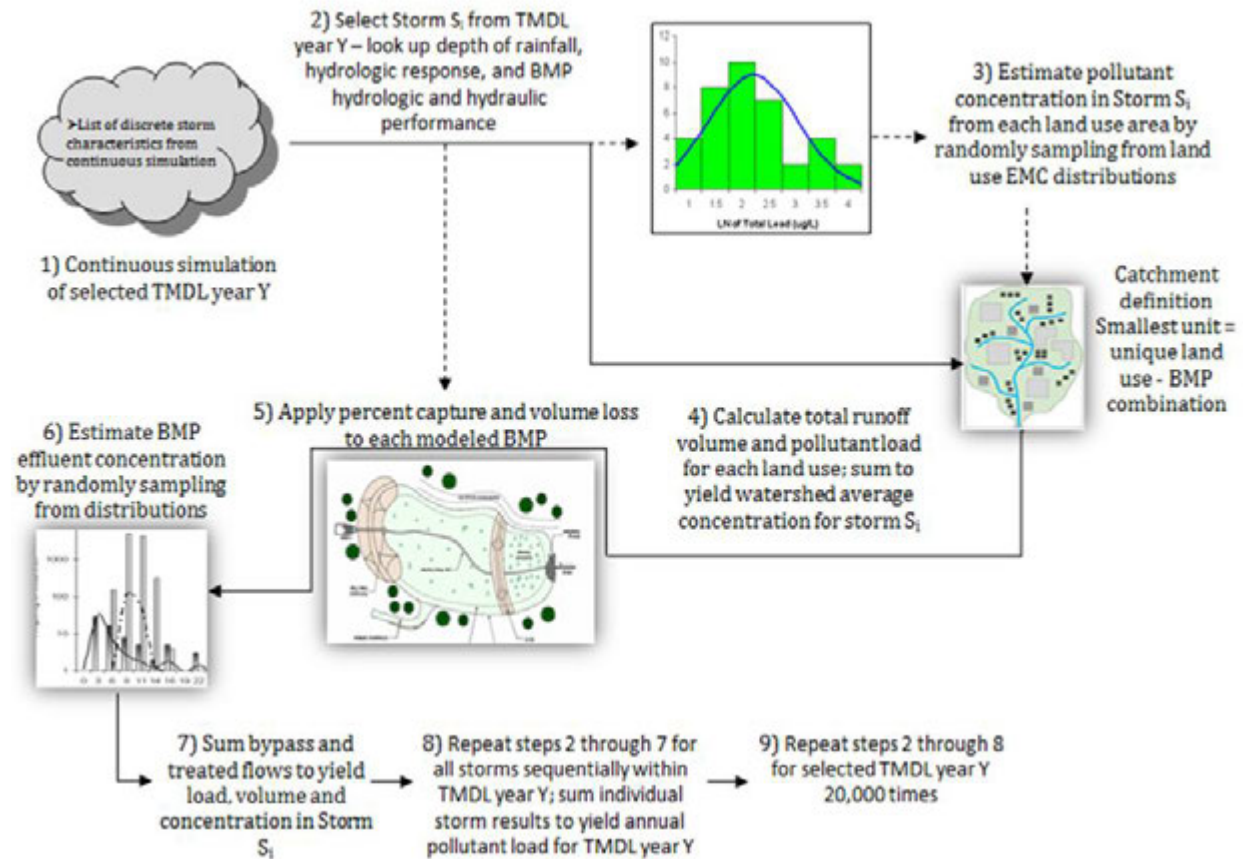

Figure A-6. Summary of SBPAT Methods to Represent BMPs in the SMB EWMP (SMB JG2/JG3 EWMP Group 2016).

## A.2 Washington Phase I MS4 Permit

---

Issued by the Washington State Department of Ecology (Ecology), the Phase I Municipal Stormwater Permit for the State of Washington regulates the discharges from MS4s owned or operated by Clark, King, Pierce and Snohomish Counties; the cities of Seattle and Tacoma and MS4s owned by public entities located in a Phase I city or county; including the Ports of Seattle and Tacoma. The MS4 permit requires each of the county permittees to conduct watershed-scale stormwater planning for one watershed within their jurisdiction. The objective of the watershed-scale stormwater planning is as follows (WDOE 2012):

“...identify a stormwater management strategy or strategies that would result in the hydrologic and water quality conditions that fully support the ‘existing uses,’ and designated uses,” as those terms are defined in WAC 173-201A-020<sup>3</sup>, throughout the stream system.”

A critical component of watershed-scale stormwater planning is modeling that demonstrates how management strategies will result in the necessary hydrologic and water quality conditions to be attained. This modeling is equivalent to an RAA, and is described in the MS4 permit with the following excerpts (WDOE 2012):

“...calibrate a continuous runoff model to the selected watershed to reflect existing hydrologic, water quality, and biologic (as represented by B-IBI score) conditions.”

“...the Permittee will use the model calibrated ...to estimate hydrologic changes from the historic condition; and predict the future hydrologic, biologic, and water quality conditions at full build-out under existing or proposed comprehensive land use management plan(s) for the watershed. Future biologic conditions shall be estimated by using a correlation of hydrologic metrics with B-IBI<sup>4</sup> scores for Puget Sound Lowland Streams<sup>5</sup>, or other similar correlation if approved by Ecology. Future water quality conditions shall be described through estimation of concentrations of, at a minimum, dissolved copper, dissolved zinc, temperature, and fecal coliform.”

“...if the estimation ...predicts water quality standards will not be met, the Permittee will use the calibrated watershed model to evaluate stormwater management strategies to meet the standards.”

“Share the results of the modeling performed by the Permittee with all other Permittees in the watershed.”

The MS4 permit requires watershed-scale stormwater planning to evaluate the effectiveness of stormwater management strategies, which must include: changes to development related codes, rules, standards, and plans; and potential future structural stormwater control projects. However, management strategies may also include: basin-specific stormwater control requirements for new and redevelopment; strategies to encourage redevelopment and infill, with an assessment of options for efficient/effective runoff controls for redevelopment projects (e.g., regional facilities), in lieu of individual site requirements; or strategies to preserve or improve other factors that influence

---

<sup>3</sup> Washington Administrative Code for water quality standards for surface waters of the State of Washington

<sup>4</sup> Benthic Index of Biotic Integrity

<sup>5</sup> DeGasperi et al. 2009

maintenance of the existing designated uses of the stream (e.g., channel restoration, in-stream culvert replacement) (WDOE 2012).

To support watershed-scale stormwater planning in Washington, EPA Region 10 (Pacific Northwest Region) funded four pilot projects in 2010 to provide modeling tools and examples of model applications that specifically address planning needs in the Puget Sound region. EPA Region 10 provided enhancements to the SUSTAIN model in order to provide direct support in the planning and cost-optimization of BMPs to address hydrological indicators of ecological health in streams. Previous versions of SUSTAIN allowed direct comparison to water quality indicators, but modifications by EPA Region 10 provided direct comparison with duration and peak flows for various return frequencies, and statistics measuring peak and base flows over a long continuous period. As a result, SUSTAIN can be used to represent multiple BMPs in the watershed and evaluate the frequency of exceedance of flow-duration based indicators (Riverson et al. 2014).

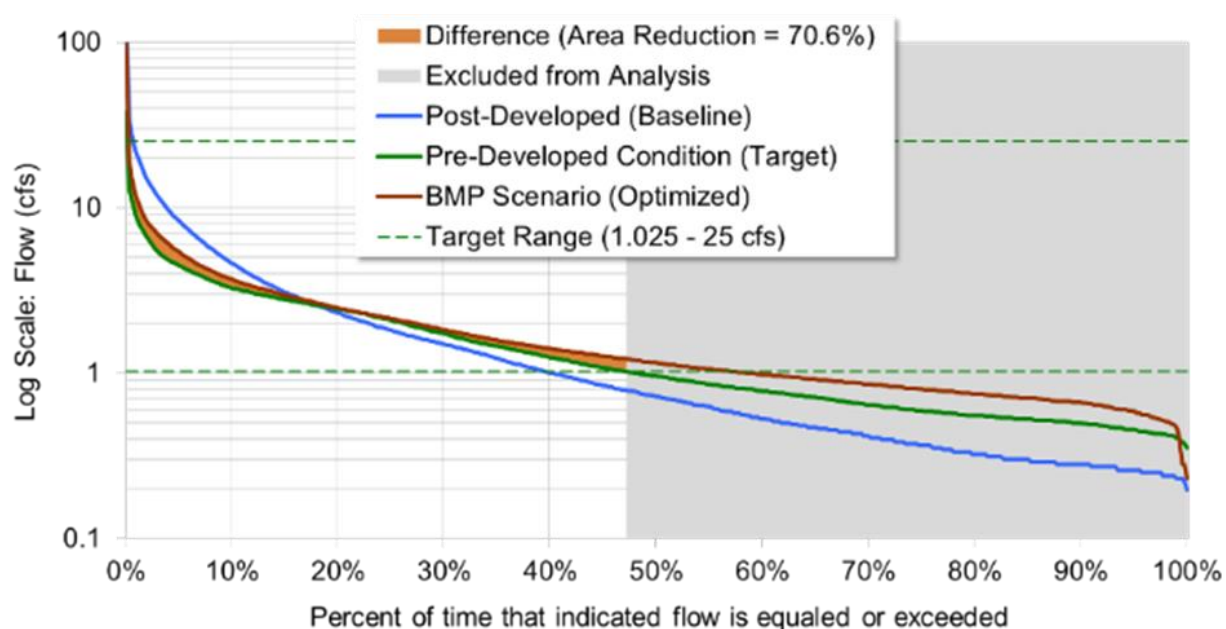

Figure A-7. EPA Region 10 SUSTAIN Flow Duration Curve Evaluation Factor for BMP Cost-Optimization (Riverson et al. 2014).

Although each county permittees has identified the watershed for which watershed-scale stormwater planning will performed, at the time of this investigation those planning efforts were not complete. However, as part of a project partially funded by EPA Region 10 through the Puget Sound Watershed Management Assistance Program, King County developed a stormwater retrofit plan and modeling approach for portions of the Green-Duwamish watershed and Central Puget Sound watersheds (King County 2013, 2014a, and 2014b). This collaborative effort of King County and EPA Region 10 serves as an example for how to perform modeling to support watershed-scale stormwater planning efforts currently underway by county permittees for other watersheds in Washington. The following case study summarizes the modeling approach used to support the King County Stormwater Retrofit Plan.

The RAA for the Stormwater Retrofit Plan for Water Resources Inventory Area (WRIA) 9 focused on modeling to reflect hydrologic, water quality, and biologic health, and improvements that could result from implementation of stormwater BMPs and LID techniques in existing and future



developed areas. In the Puget Sound Region, critical conditions are generally defined based on hydrologic metrics used to evaluate Benthic Index of Biotic Integrity, or B-IBI scores as the target. A B-IBI score aggregates both hydrology and water quality objectives into a single metric that quantifies benthic health and stream conditions of an existing condition relative to a desired healthy condition. Using the calibrated watershed model, a “pre-developed” condition is derived by converting existing land cover to historical conditions (i.e. forested and/or barren land). B-IBI metrics are then computed for both existing and forested conditions. Examples of the metrics used for the King County RAA are presented in Table A-3. The metrics derived for the “pre-developed” scenario become the stormwater improvement goals for the existing condition. The methodology for addressing the impairment is to identify BMPs that minimize the difference between the existing and pre-developed condition flow-duration curves.

**Table A-3. Hydrologic metrics (B-IBI indicators) applied for the Stormwater Retrofit Plan for Water Resources Inventory Area 9 (King County 2014a and 2014b)**

WRIA 9 Metrics	Description
High Pulse Count (HPC)	The number of times the daily mean flow rate exceeds two times the long-term mean annual flow rate per water year
High Pulse Range (HPR)	The number of days between the first and the last high pulse of the water year
PEAK:BASE	Ratio of the peak 2-year return flow to the annual average winter base flow (i.e. base flow separated from storm flows) between October and April (Horner 2013)

## **Stormwater Retrofit Plan for Water Resources Inventory Area 9**

A stormwater retrofit plan was prepared by King County to develop a cost estimate for implementing stormwater BMPs and LID techniques in existing and future developed areas to improve flow and water quality and support biological health. The plan addressed 278 square miles of the Green-Duwamish watershed and portions of the Central Puget Sound watershed that comprise the WRIA 9. Modeling served as a critical component of the plan, which included a combination of HSPF and SUSTAIN to simulate hydrology, water quality, and BMP performance, and provide cost-optimization to select cost-effective BMP and LID strategies throughout the study area to meet water quality and flow-based targets (King County 2013, 2014a, and 2014b).

**Element 1:** As the stormwater retrofit plan was not developed to directly address requirements of the MS4 permit, the plan did not emphasize the separation of MS4 and non-MS4 areas. However, the plan did exclude portions of the City of Seattle within WRIA 9 as this area is served by a combined sewer and stormwater system and a combined sewer overflow (CSO) control program was underway within the City. The plan also excluded portions of WRIA 9 upstream of Howard Hanson Dam as this area is primarily forested and maintained to protect water supply.

**Element 2:** An HSPF model of the watershed was configured for hourly simulation of hydrology and sediment loads for 446 catchments ranging in size from 0.21 to 3,567 acres. The model was configured to represent existing conditions based on multiple available GIS datasets defining the physical characteristics of the watershed, including topography, geology, and 2007 land use. The model was calibrated based on comparison of model output with flow measurements (Figure A-8) and TSS monitoring data collected at multiple locations in the study area. Model performance was evaluated based on multiple statistical analyses and comparison to ranges of sediment loading rates reported in literature (King County 2013).

**Element 3:** Based on spatial projections of future land use, the calibrated HSPF model was reconfigured to simulate hydrology and sediment loading in the year 2040. Population increase projected by 2040 is expected to result in the conversion of additional land for urban use, and the redevelopment of previously developed land for higher density use. SUSTAIN was used to evaluate the management scenarios to meet hydrologic and water quality indicators. The goals of the SUSTAIN modeling included: (1) optimization of BMPs and estimation of their effectiveness at reducing flow and sediment loads for hypothetical catchments with unique combinations of land use and other physical characteristics, (2) scaling of these solutions to the study area for the 2040 future land use scenario. The BMP solutions were scaled to the study area to achieve maximum effectiveness, but not beyond conditions for a fully-forested watershed (King County 2014a).

**Element 4:** SUSTAIN was used to model three management options for a stormwater program, including: (1) required stormwater management occurring with new and redevelopment, (2) stormwater retrofit of roads and highways, and (3) stormwater retrofit of non-road unchanged development. Option 1 assumed BMPs are installed with new and redevelopment (e.g., LID) as outlined in current stormwater guidelines. Option 2 assumed BMPs are installed to capture runoff from local roads and highways (e.g., bioretention and detention ponds). Option 3 assumed BMPs are installed to control or treat runoff from the remaining developed area (e.g., cisterns, rain gardens, and detention ponds). Figure A-9 shows an example BMP routing network used. SUSTAIN provided quantification of the improvement of indicators with incremental increase of stormwater management for the three options. These scenarios were compared to modeled existing conditions in 2007 and future conditions in 2040 with no stormwater management, and fully-forested conditions. Results of the SUSTAIN modeling scenarios were evaluated regarding the amount of BMPs and their costs and effectiveness at meeting hydrologic and water quality indicators, as compared to scenarios of fully-forested and existing and future conditions without BMPs. Multiple pollutants and measures of stream biological health were assessed based on the multiple modeling scenarios, which included comparison of pollutant loads, percent of time water quality standards were exceeded (Figure A-10), and various metrics for evaluating B-IBI scores (Figure A-11). Model results were also reported in a series of maps that show the spatial distribution of B-IBI scores for the various model catchments (Figure A-12) (King County 2014a).

**Element 5:** The plan reported the number, storage volumes, and costs of BMPs for the various model scenarios for each city/county jurisdiction and catchment in the study area using tables and maps (Figure 4-7) that provide a useful guide for future implementation efforts (King County 2014a and 2014b).

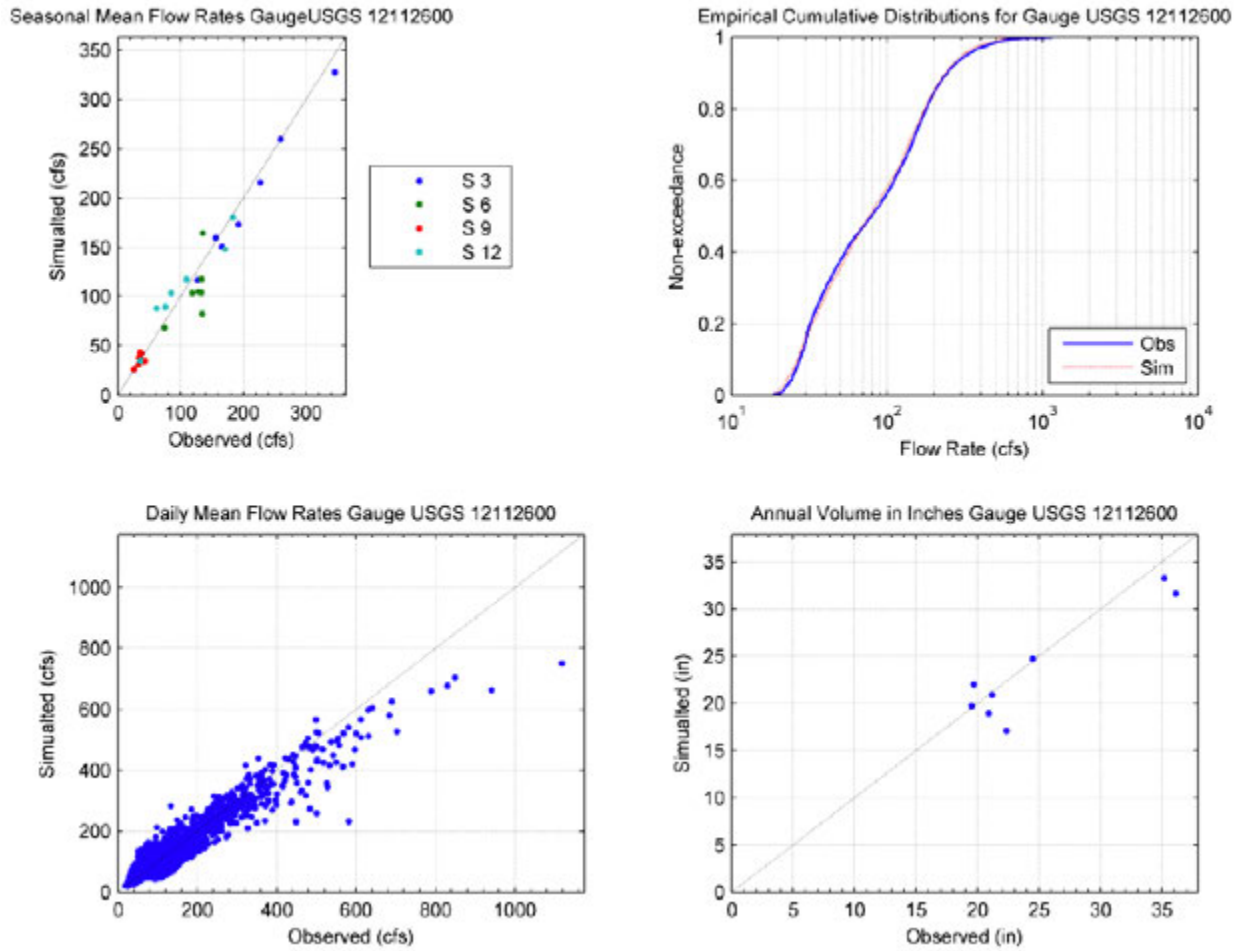

Figure A-8. Model Hydrology Calibration for Big Soos Creek (King County 2013).

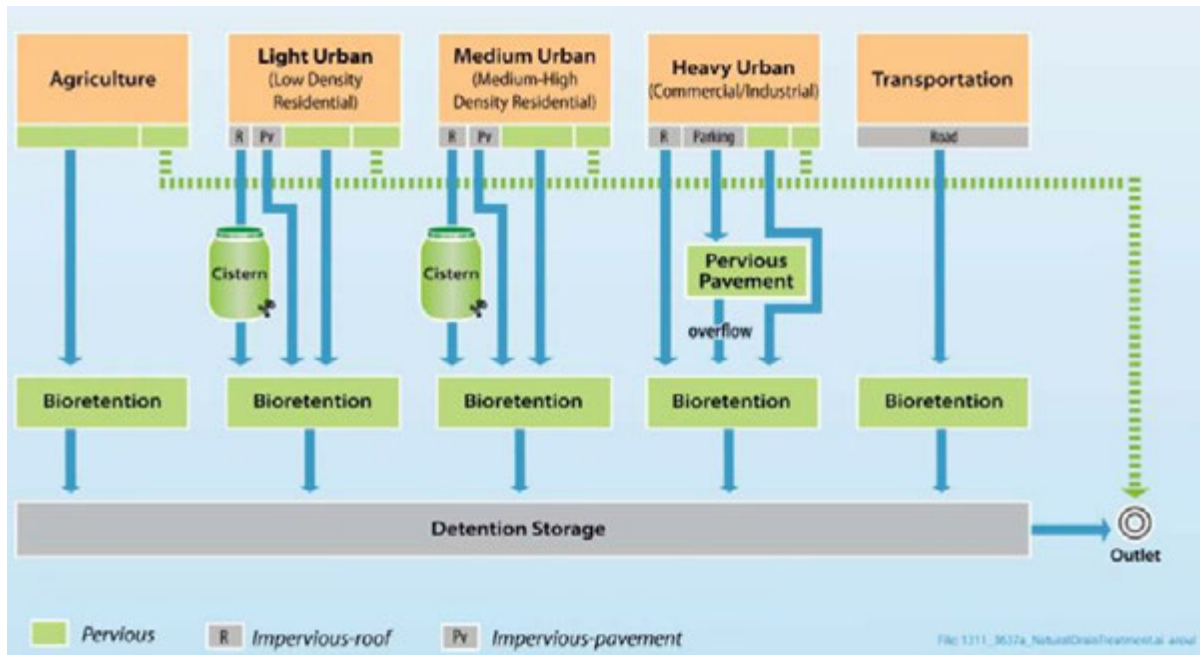

Figure A-9. Example Model Configuration and Routing Network for BMPs for the Stormwater Retrofit Plan for Water Resources Inventory Area 9 (King County 2014a).

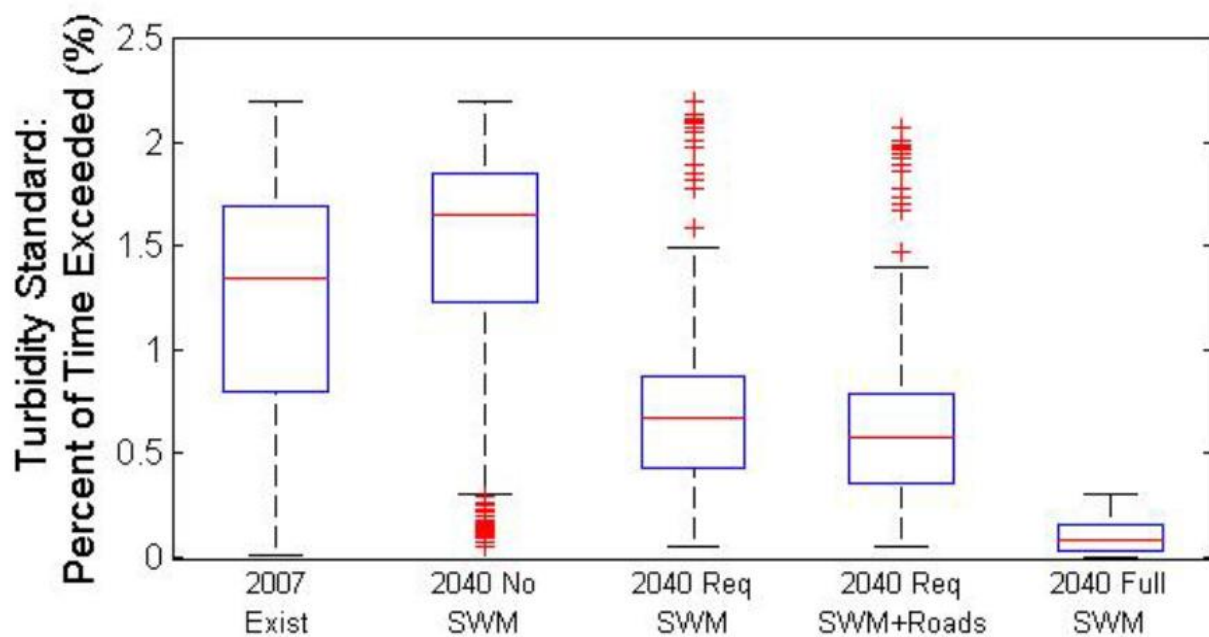

Figure A-10. Percent of Time Exceeding Turbidity Standards – Stormwater Retrofit Plan for Water Resources Inventory Area 9 (King County 2014a).<sup>6</sup>

<sup>6</sup> No SWM = No Stormwater Management; Req SWM = Required Stormwater Management for new and redevelopment; Req SWM+Roads = Req SWM plus stormwater management for roads and highways; Full SWM = Full Stormwater Management (Req SWM+Roads plus BMP retrofit for other developed areas). The ranges of results shown in the figure for each scenario represent the variability of results for the 446 individual model subwatersheds.

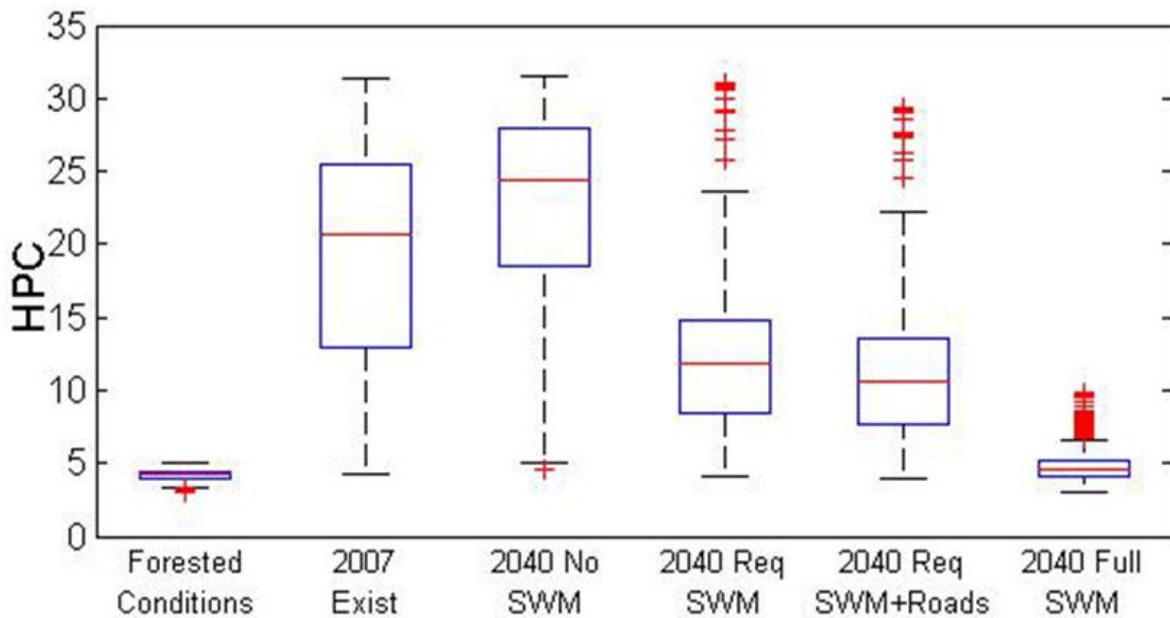

Figure A-11. Probability of Improving B-IBI Scores<sup>7</sup> above 40% of the Maximum Standards – Stormwater Retrofit Plan for Water Resources Inventory Area 9 (King County 2014a).

<sup>7</sup> High Pulse County (HPC) served as a hydrologic metric to measure B-IBI based on the number of times in a water year the daily mean flow exceeds twice the long-term daily mean annual flow (Horner 2013). The ranges of results shown in the figure for each scenario represent the variability of results for the 446 individual model subwatersheds.

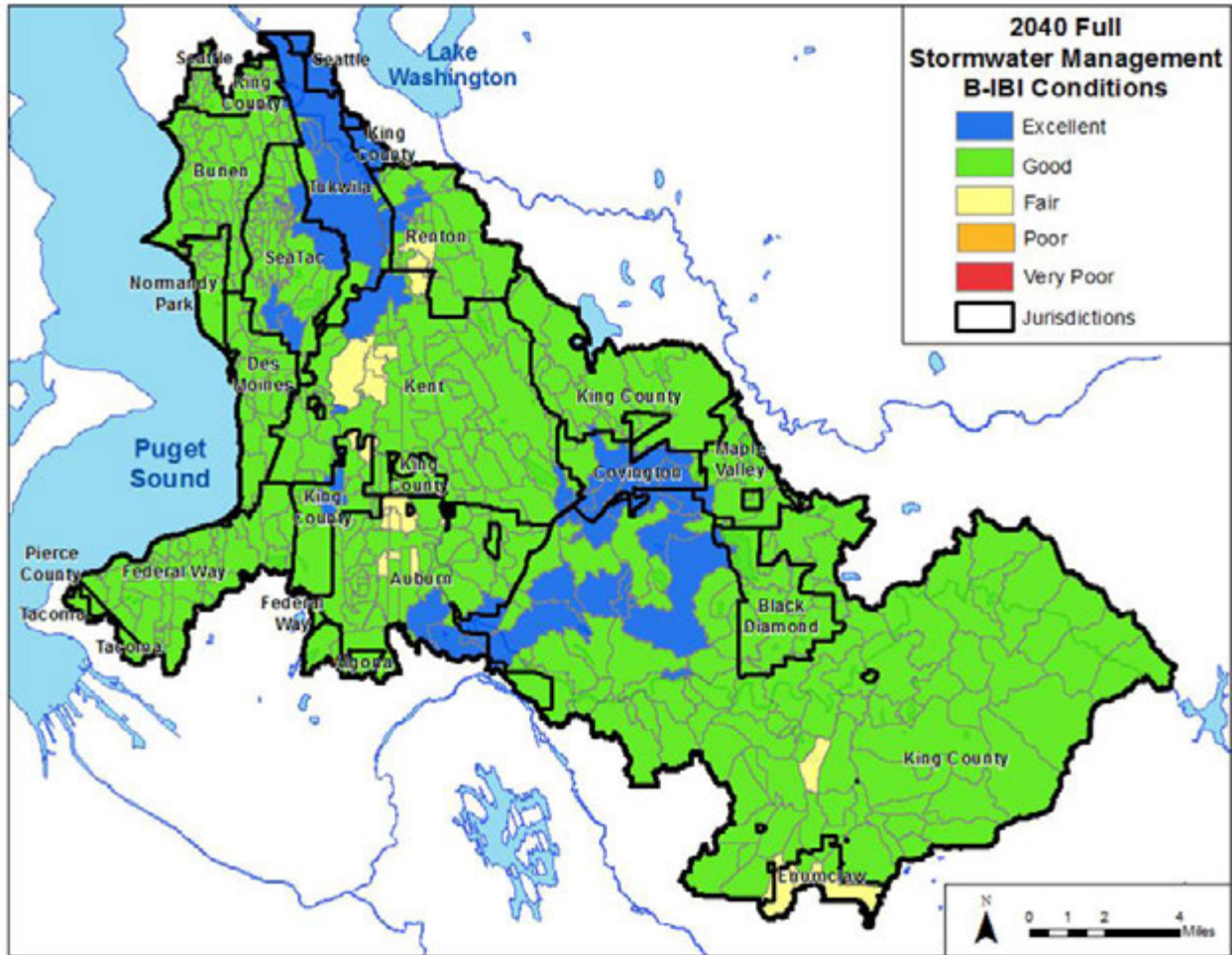

Figure A-12. WRIA 9 Study Area Biological Conditions for 2040 with Full Stormwater Management – Based on the Relationship with HPC and 90% Upper Confidence Limit (King County 2014a)

### A.3 San Diego Region Phase I MS4 Permit

---

Adopted in 2015, the NPDES Permit No. CAS0109266 for discharges from MS4s within the San Diego Region (San Diego Region MS4 Permit) includes provisions for development of Water Quality Improvement Plans (WQIPs) for each watershed in the region. The San Diego Region MS4 Permit describes the WQIP as:

...an adaptive planning and management process that identifies the highest priority water quality conditions within a watershed and implements strategies through the jurisdictional runoff management programs to achieve improvements in the quality of discharges from the MS4 and receiving waters.”

A copermitttee has the option to utilize the WQIP to demonstrate compliance with requirements for discharge prohibitions, receiving water limitations, and WQBELs established in the permit. The WQBELs were based on the TMDL WLAs. To be eligible for this option, the WQIP must incorporate multiple planning procedures and meet specific permit requirements, including an RAA that quantitatively demonstrates that the implementation of water quality improvement strategies will result in the attainment of the WQBELs within associated implementation schedules (SDRWQCB 2015).

The San Diego Region MS4 permit includes additional guidance for WQIPs that address WQBELs. For WQBELs that are not currently met by copermitttees, the permit allows a WQIP to include an analysis, “utilizing a watershed model or other watershed analytical tools,” to demonstrate that the implementation of BMPs will result in the attainment of applicable receiving water or effluent limitations (SDRWQCB 2015). Prior to the adoption of the San Diego Region Permit in 2015, the previous MS4 permit for San Diego County MS4s included similar requirements for WQIPs to address WQBELs. To meet these previous MS4 permit requirements, San Diego County copermitttees have developed WQIPs for multiple watersheds. Most of these WQIPs included RAAs to address compliance with WQBELs; however, the previous MS4 permit did not include alternative compliance mechanisms consistent with the new San Diego Region MS4 Permit to enable permittees to meet discharge prohibitions and receiving water limitations through implementation of the WQIPs.

Unlike the Los Angeles Region, the San Diego Regional Water Quality Control Board (SDRWQCB) did not provide detailed descriptions in the San Diego Region MS4 Permit that defined the expectations of an RAA or specific modeling approaches to be used. Nor did the Regional Board provide supplemental RAA guidance. This approach allowed flexibility for permittees to develop technical approaches for RAAs to respond to the permit requirements. However, lack of guidance from the SDRWQCB also resulted in uncertainty in terms of the expectations of the SDRWQCB, which was often not realized until WQIPs were completed and submitted to the SDRWQCB for review. Prior to the development of WQIPs, several copermitttees had developed Comprehensive Load Reduction Plans (CLRPs) to comply with specific implementation requirements of bacteria TMDLs for multiple beaches and creeks throughout the region (SDRWQCB 2010) and a sedimentation TMDL for Los Peñasquitos Lagoon (SDRWQCB 2012). These CLRPs included modeling approaches that were consistent with RAAs (e.g., LSPC, SUSTAIN, SBPAT), however, the SDRWQCB did not provide comments on the CLRPs regarding their sufficiency at demonstrating reasonable assurance for compliance with TMDLs. Regardless, for those WQIP that benefited from previous CLRPs developed, models used to support the CLRPs were adapted for RAAs used in the WQIPs.

As a result of the above, RAAs performed in the region to support WQIPs varied significantly in the methods used to interpret WQBELs and report results to demonstrate that BMPs will be sufficient to provide attainment of applicable receiving water or effluent limitations. Although models used to support RAAs were typically consistent with those performed in the Los Angeles Region, the use of the models and reporting of results varied. For example, no criteria were established by the SDRWQCB regarding the technical expectations of models in simulating existing conditions (e.g., calibration statistics). Although the WQIPs document the calibration (and in some cases validation) of the models used, the metrics for which performance was evaluated vary between WQIPs, as well as in comparison to WMPs developed in the Los Angeles Region where more specific performance metrics were established by the LARWQCB.

Eight WQIPs have been completed in the San Diego County to respond to MS4 permit requirements preceding the 2015 adoption of the San Diego Region MS4 Permit. As the previous permit emphasized RAAs to justify a WQIP's demonstration of compliance with WQBELs, four of those WQIPs with applicable WQBELs included robust RAAs. Additional WQIPs (potentially including RAAs) will be developed by Orange County and Riverside County with their addition to the San Diego Region MS4 Permit in 2015. Should other copermittees choose to use the WQIP as an option to demonstrate compliance with discharge prohibitions and/or receiving water limitations authorized in the 2015 San Diego Region MS4 Permit, other WQIPs may be revised to include RAAs in the future. An example of the RAA performed to support the Los Peñasquitos Watershed Management Area WQIP and CLRP (LP WMA Responsible Agencies 2015) is discussed on the following page.



## **Los Peñasquitos Watershed Management Area WQIP and CLRP**

A WQIP was prepared for the Los Peñasquitos Watershed Management Area (WMA) by the cities of San Diego, Del Mar, Poway, the County of San Diego, and the California Department of Transportation (Caltrans). The WQIP also serves as a CLRP to demonstrate compliance with specific requirements of the TMDL for sedimentation in Los Peñasquitos Lagoon (SDRWQCB 2012). The WMA addressed by the WQIP includes 94 square miles of urban land and undeveloped space that drains to the Los Peñasquitos Lagoon. The RAA for the WQIP was based on a combination of models including LSPC and SUSTAIN (LP WMA Responsible Agencies 2015).

**Element 1:** Although the San Diego Region MS4 Permit only addresses dischargers from the MS4s, bacteria and sediment TMDL allocations in the watershed are less clear regarding the distinction of responsibility for copermitees, other NPDES permits, and nonpoint sources (Figure 4-1). For example, the bacteria TMDL assigns a single wasteload allocation for the WMA to Phase I MS4s, although non-MS4 areas within the WMA contribute to bacteria loads. Although Caltrans voluntarily participated in the WQIP, non-MS4 areas typically do not have responsibility to address the TMDL through reductions of sediment and bacteria. Given these inconsistencies and lack of clarity on how responsible dischargers are identified in the TMDLs, the WQIP and associated RAA included the entire WMA in the analysis (including MS4 and non-MS4 areas). However, pollutant loads for MS4 and non-MS4 areas were differentiated in the RAA to assess load reduction responsibilities in the WMA. This provided the ability to assess cost implications of copermitees being held accountable for WMA-wide TMDL pollutant reduction requirements.

**Element 2:** Prior to the WQIP, an LSPC model of the WMA was available through previous efforts supporting development of the sediment TMDL and CLRP. The model was refined for use in the RAA, and included hourly simulation of hydrology and sediment and bacteria loads for multiple model subwatersheds, including loads from various urban and non-urban land uses, pervious and impervious areas, and instream sources of sediment resulting from hydromodification. Results of the hydrologic and water quality calibration were documented in the WQIP, although limited statistical metrics were used to evaluate the performance of the model as compared to observed water quality data. The model was used to assess relative sediment (Figure 4-4) and bacteria loads throughout subwatersheds of the WMA to prioritize areas for management.

**Element 3:** The WQIP established numeric goals to be used to measure progress toward addressing the highest priority water quality conditions for the WMA: sedimentation and bacteria. The sediment TMDL established two numeric targets specific to the lagoon and watershed, based on reference conditions related to the state of the watershed and lagoon in the mid-1970s. For the interpretation of the TMDL watershed target as a numeric goal for the WQIP, the LSPC model was used to simulate subwatershed sediment loading for 2009 (based on available land use data) and the mid-1970s, and the difference in these loads represented the sediment load reduction goals for the WQIP. For bacteria, numeric goals were established based on load reduction calculations performed in the TMDL. These numeric goals, in combination with other quantifiable goals related to lagoon restoration and the frequency of exceedance of receiving water quality objectives for indicator bacteria, were summarized for each responsible agency.

**Element 4:** The RAA was performed based on a combination of LSPC and SUSTAIN to estimate load reductions associated with BMP implementation strategies within each jurisdiction. The RAA assumed 10% wet weather reduction resulting from numerous non-modeled nonstructural BMPs, with LSPC simulating additional reductions associated with catch basin cleaning, downspout disconnection incentive programs, irrigation runoff reduction, rain barrels, and street sweeping. For each jurisdiction, SUSTAIN was used to model and provide cost-optimization of wet weather load reductions associated with structural BMPs, resulting in selection of cost-effective implementation strategies over time to meet interim and final numeric goals (Figure A-13). Significant dry weather load reductions were assumed to result from nonstructural BMPs, with additional load reductions expected through the implementation of structural BMPs.

**Element 5:** Results of the RAA are presented in the WQIP using figures, tables, and schedules that present the pollutant load reductions associated with the combination of BMPs over time (Figure 4-8). The amount of structural BMPs required to provide these reductions are not fully documented (e.g., stormwater volumes managed with individual types of BMPs in each subwatershed), which will put emphasis on annual reports to present and track ongoing status of BMP implementation and progress towards attainment of numeric goals.

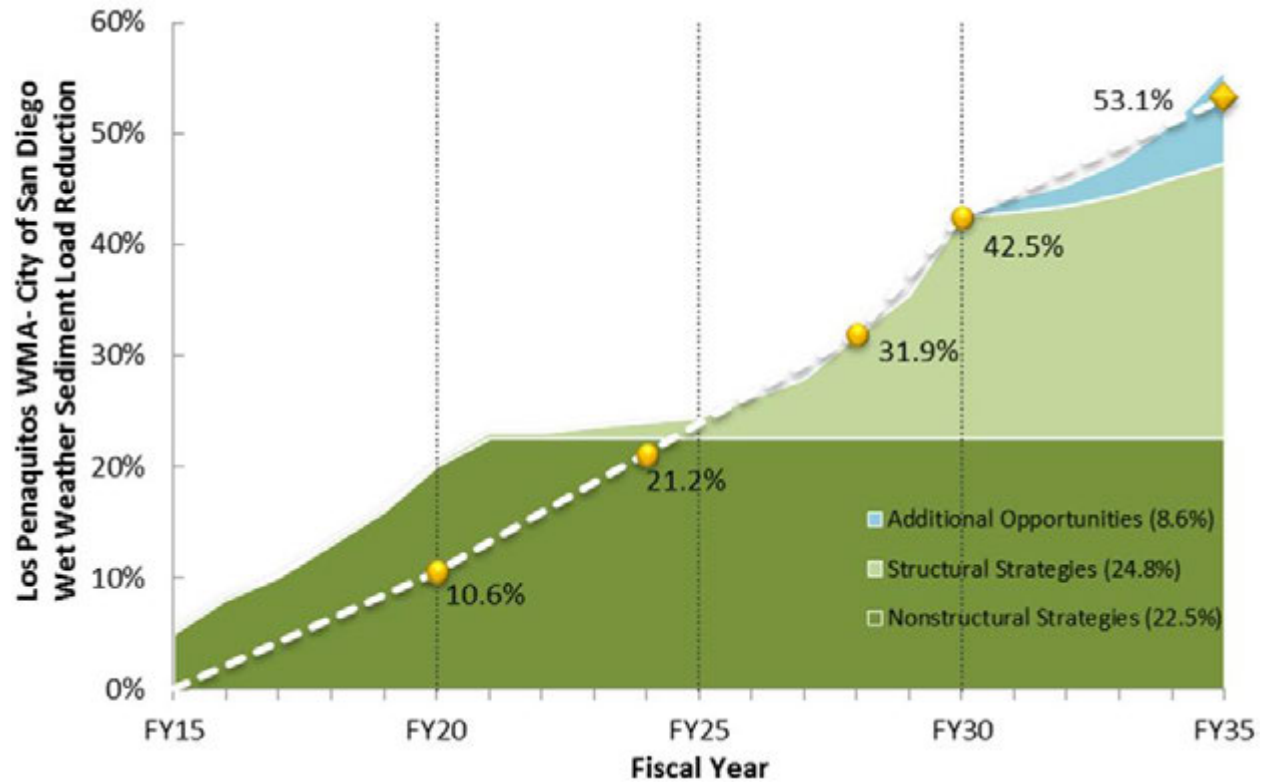

Figure A-13. Los Peñasquitos WQIP Example Wet Weather Compliance Schedule for City of San Diego (LP WQIP Responsible Agencies 2015).

## A.4 Central Coast California Phase I and Phase II MS4 Permit

---

The State Water Resources Control Board adopted Water Quality Order No. 2013-001-DWQ NPDES General Permit No. CAS00004, Waste Discharge Requirements for Stormwater Dischargers from Small Municipal Storm Sewer Systems (Phase II Municipal Stormwater Permit) on February 5, 2013. The Phase II Municipal Stormwater Permit is applicable to the 38 enrolled Central Coast Phase II communities. In addition, the Central Coast Regional Water Quality Control Board adopted Order No. R3-2012-0005 NPDES Permit No. CA0049981 for the Phase I City of Salinas. As such, all Permittees are required to develop, implement, assess, and report overall program effectiveness in a way that that quantitatively links stormwater management practices with water quality improvements in the receiving water. In addition to reporting progress, program effectiveness assessments inform stormwater quality management decisions to improve managers' capacity to protect receiving water quality and beneficial uses (Phase II Permit Section E.14). A number of the Central Coast Permittees discharge stormwater to a 303d listed receiving waterbody that either currently has an established TMDL wasteload allocation or may have a formal TMDL wasteload allocation within the next 5 years, which would trigger TMDL monitoring requirements (E.13). Tracking and quantification of program effectiveness compliance can address many additional permit requirements, such as identifying and documenting hydrologic linkages between the municipal separate storm sewer system (MS4) and the associated receiving waters to which it discharges (Section E.9); developing inventories of existing programmatic and structural best management practices (BMPs) implemented and assessing the effectiveness of these BMPs to reduce pollutant loading to the receiving water (Section E.11); and establishing a mechanism for practical information feedback and adaptation actions to optimize resource allocations by prioritizing maintenance actions and identifying where new BMPs are expected to have the greatest receiving water benefits (E.14, E.15).

The Central Coast Regional Water Quality Control Board is encouraging an iterative approach to RAAs by placing practical stormwater planning and accounting tools in the hands of stormwater managers. A suite of guidance documents and customized stormwater software tools are available to assist municipalities to more efficiently meet annual MS4 permit requirements. The assessment and modeling tools are designed for direct use by municipal staff to reduce reliance on high resolution water quality monitoring data collection, complex software systems, and modelling experts. These tools were collaboratively developed and continue to be refined with regulatory agencies and municipal stormwater staff to ensure the needs of both are met. Structural and non-structural BMPs within the MS4 are assessed regularly by using customized practical monitoring tools that allow objective performance evaluations for hundreds of structural BMPs ([www.bmpram.com](http://www.bmpram.com)) or widespread implementation of non-structural BMPs on parcels ([www.parcelram.com](http://www.parcelram.com)) or roads (e.g., [www.tahoeroadram.com](http://www.tahoeroadram.com)). Anyone with a day of training can become proficient with the applications and generate precise and meaningful BMP effectiveness data.

Through a shared spatial database, the BMP design and assessment data are inputs to quantify pollutant load reductions via the stormwater Tool to Estimate Load Reductions (TELRL; [www.swtelr.com](http://www.swtelr.com)). TELRL is a proprietary, urban hydrology and pollutant loading model purpose-built to reduce required user expertise, input data needs, and output uncertainty. TELRL includes only the most influential determinants on rainfall-runoff transformation, pollutant generation, and runoff and pollutant BMP reductions. Simplifying assumptions are used by TELRL to reduce the complexity inherent in water quality and focus stormwater management on the implementation and maintenance of actions expected to have the greatest water quality benefits. Use of these custom-built monitoring and modeling tools seamlessly integrates planning and implementation tracking by turning water quality data into information to evaluate stormwater program effectiveness and

identify spatial opportunities for water quality improvements. The online map-based data management and reporting system generates watershed based results are easy to interpret and communicate to many. The relative risk of stormwater impacts on receiving water quality is consistently quantified allowing comparisons of pollutant loading over space and time. The relative water quality risk determination is informed by regular and continued on-the-ground assessments to verify that structural and non-structural BMPs are effectively implemented. By incorporating BMP effectiveness data for actual BMPs on the landscape, the continued commitment to operations and maintenance to sustain water quality benefits is paramount. Standardization of methods, terminology, and outputs provide a common language in accessible formats to compare and aggregate results, greatly improving communication about stormwater quality. The iterative annual feedback of program progress and current priorities allows stormwater managers and regulators to adapt management decisions as new information become available. This approach can inform more detailed research on BMP or program effectiveness and where focused water quality evaluations may be most valuable.

The following provides a summary of an application of TELR software for the City of Pacific Grove and Monterey relative to the five basic elements of an RAA.

## **City of Pacific Grove and City of Monterey: ASBS Low Impact Development Planning and Future Implementation**

This case study provides a summary of the application the TELR software to a specific municipal planning, funding, and future implementation example; the process, tools and reporting formats are purposely standardized and scalable to any MS4.

**Element 1:** The approach is spatially explicit and requires an understanding and documentation of stormwater routing from the MS4 to receiving waters to which they drain. Online maps serve at the organizational foundation for data inputs and analysis of results. Each Permittee follows a pragmatic process to obtain data, assesses actual BMP effectiveness to inform maintenance and track programmatic progress. In addition, the use of these tools across Central Coast municipalities allows regional comparisons and collaboration to set and track progress toward achieving TMDLs, stormwater plans, watershed plans, or other water quality objectives. Figure A-14 presents the catchment delineation and land use distribution for the Area of Special Biological Significance (ASBS) drainage area.

**Element 2:** Unmitigated runoff and loading estimates for all MS4 catchments are generated with TELR using land use characteristics, rainfall, and urban drainage delineations to receiving waters assuming no BMP implementation. This simplifies the complexity of recreating past landscape development, BMP distribution, BMP sizing and BMP effectiveness, as well as the uncertainty introduced by making assumptions of such past conditions. As a precursor to characterizing existing condition, unmitigated results provide a quantitative baseline from which water quality improvement is measured. Spatial outputs are normalized by catchment area to show the distribution of relative runoff and pollutant loading problems within the municipality. Figure A-15 presents TELR automated graphical displays of baseline particulate loading.

**Element 3:** Each municipality will identify stormwater goals by focusing on achieving and sustaining effective stormwater and pollutant controls in catchments identified with the greatest relative risk to receiving water quality. The difference between unmitigated (Figure A-15) and existing conditions (with BMPs) quantifies the load reduction to receiving waters achieved by BMPs implemented throughout the municipality. These load reductions provide both spatial and numeric basis to focus the municipality on implementing water quality improvements that they can affect. Stormwater improvement goals can be defined by relative runoff and pollutant load reductions from baseline or current conditions using TELR. The mapped products also provide a watershed context for MS4 discharges to impaired waterbodies to improve discussions and expectations surrounding TMDL wasteload allocation attainment.

**Element 4:** TELR planning scenarios allow users to quantify the expected water quality benefits for planned improvements in priority catchments and to easily communicate these expected benefits to funders, regulators and the community. In the process of planning to evaluate alternatives and the pursuit of funding for implementation, the TELR planning scenario can be created to quantify the predicted water quality benefit of the planned improvements. Figure A-16 display the planned structural BMPs components of the LID plan (as designed by engineers) within the catchments of the ASBS drainage area. The average annual particulate (Figure A-16) load reductions predicted are documented for each catchment with a 42.4 T/yr total load reduction to the ASBS should the project be implemented as designed and BMP maintained. Map catchment shading in Figure A-16 summarizes the revised catchment prioritization should the LID project be implemented as designed, illustrating the iterative implementation and planning process.

**Element 5:** TELR and the supporting assessment tools are made available via an integrated web-based spatial application ([www.2nform.com](http://www.2nform.com)) and allow quantification of progress based on actual implementation and effectiveness year after year. Once implementation occurs, BMP RAM is used to inventory and assess the installed BMPs and these data are used by TELR to quantify the benefits achieved based on both sizing and observed performance. Over time and space the municipality can track and demonstrate that the intended stormwater improvement goals have been achieved. This iterative approach provides a long-term process by which priorities are identified, water quality improvement actions are implemented and maintenance is conducted, progress is quantified and documented, and the new current conditions are then used to inform the next priorities.

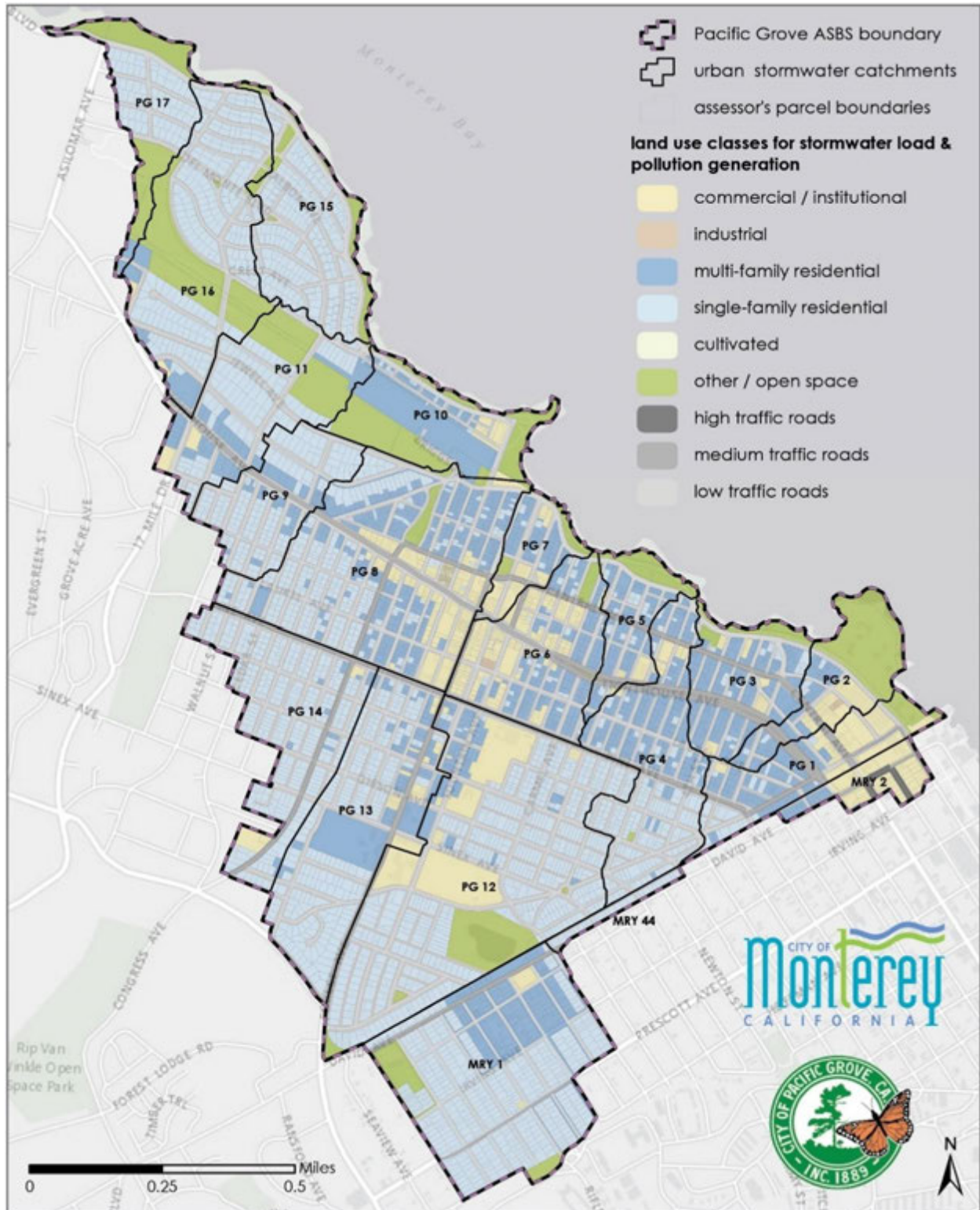

Figure A-14. City of Monterey and Pacific Grove MS4 Areas Draining to the Pacific Grove ASBS (delineated into unique urban drainage catchments and categorized into standardized land use types).

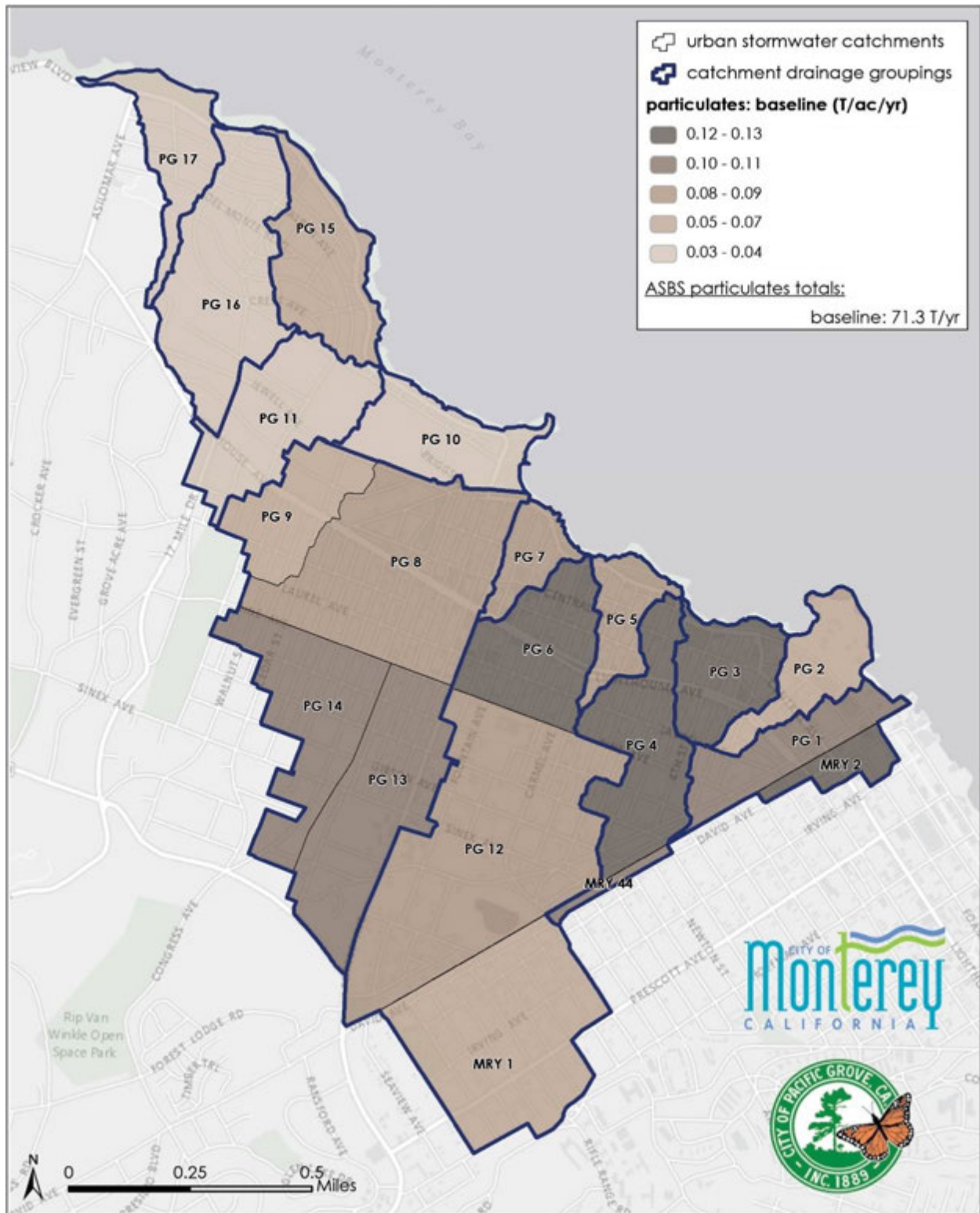

Figure A-15. TELR Scenario without BMPs to Generate a Baseline Average Annual Particulate Loads for Each Catchment.

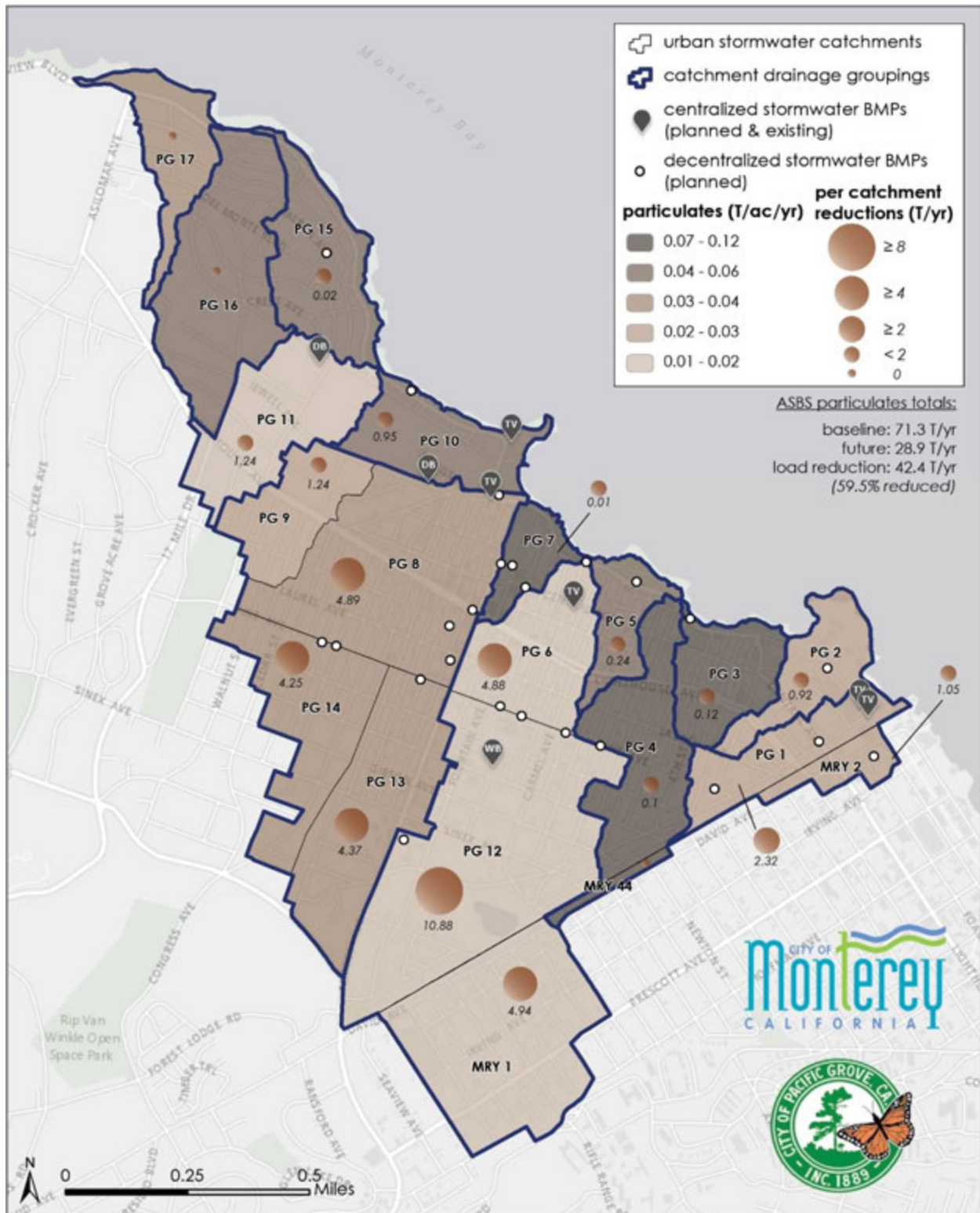

Figure A-16. TELR Planning Scenario Results Given the Future Mapped Distribution of Structural BMPs.



## A.5 San Francisco Bay Area Regional MS4 Permit and GreenPlan-IT

---

Issued in 2015, San Francisco Bay Regional Stormwater NPDES Permit (CAS612008) regulates the discharge of stormwater runoff from MS4s within San Francisco Bay Region that includes Alameda County, Contra Costa County, Santa Clara County, San Mateo County, and the cities of Fairfield, Suisun City, and Vallejo. The MS4 permit includes a provision that requires each of the permittees to develop and implement a Green Infrastructure (GI) Plan within their jurisdiction to include low impact development drainage design into storm drain infrastructure on public and private lands. The intention of the plan is described in the permit as:

“...serve as an implementation guide and reporting tool during this and subsequent Permit terms to provide reasonable assurance that urban runoff TMDL wasteload allocations (e.g., for the San Francisco Bay mercury and PCBs TMDLs) will be met, and to set goals for reducing, over the long term, the adverse water quality impacts of urbanization and urban runoff on receiving waters”

The GI Plan must be developed using “a mechanism (e.g., SFEI’s GreenPlanIT tool or another tool) to prioritize and map areas for potential and planned projects, both public and private, on a drainage-area-specific basis” for implementation by 2020, 2030, and 2040.

The San Francisco regional permit also includes two provisions that require the permittees to prepare a plan for PCBs and mercury control measure implementation and also conduct an RAA that demonstrates sufficient control measures will be implemented to attain the PCBs TMDL wasteload allocations by 2030 and mercury TMDL wasteload allocations by 2028. The permit provides clear expectations of an RAA but also offers flexibility for permittees to define what constitutes an acceptable RAA. Los Angeles region guidelines are suggested as a starting point to conduct RAA for PCBs and mercury for the San Francisco Bay Area in terms of the mechanics of the analysis, control measure identification, critical condition selection, choice of models, model calibration criteria, and modeling inputs and outputs. Local watershed characteristics must be included in the RAA, as well as what has been learned about the distribution, fate, and transport characteristics of PCBs and mercury.

To support the development of GI Plans and RAAs for PCBs and mercury in the San Francisco Bay Area, San Francisco Estuary Institute (SFEI), in partnership with San Francisco Estuary Partnership (SFEP) and a number of City and County agencies and funded by State Water Resources Control Board (SWRCB) and EPA Region 9, developed a planning tool (GreenPlan-IT) that is specifically designed to address these planning needs. GreenPlan-IT combines sound science and engineering principles with GIS analysis and modeling tools to support the cost-effective selection and placement of GI at the watershed scale and the development of quantitatively-derived watershed master plans to guide future GI implementation. GreenPlan-IT comprises four standalone tools: (a) a GIS-based Site Locator Tool that combines the physical properties of different GI types with watershed GIS information to identify and rank potential GI locations; (b) a Modeling Tool that is built on EPA’s SWMM model to establish baseline conditions and quantify anticipated runoff and pollutant load reductions from GI sites; (c) an Optimization Tool that uses a cost-benefit analysis to identify the best combinations of GI types and number of sites within a watershed for achieving flow and/or load reduction goals; and (d) a tracker tool that is used to track GI implementation and report the cumulative programmatic outcomes for regulatory compliance and other communication needs.

GreenPlan-IT is currently being applied within a number of city and county areas in the San Francisco Bay Area to support the development of watershed-scale GI Plans for permit compliance.

One example of the tool applications is a case study in the City of San Jose, where the cost-effective LID scenarios for PCBs control was identified for a 4300-acre priority development area in the downtown area. The results of the application included a cost-benefit analysis for a range of flow reduction targets, ranking of sites for specific optimal solutions, and maps showing the distribution of LID within the focus area under a specific optimal solution portfolio. These results are being used to identify specific GI projects, support the City's current and future planning efforts, and facilitate compliance with permit requirements. Similar applications are currently ongoing in the cities of Oakland, Sunnyvale, and Richmond, as well as in Contra Costa County.

GreenPlan-IT had been developed through a public process with inputs and guidance from stakeholders and is publicly available for use. The versatility of tool's functions, availability, and general acceptance of the tool in the region makes it an ideal tool for supporting RAAs. Although, at present, GreenPlan-IT has not been used for an RAA, the tool meets all the specifications of the Los Angeles guidance for performing an RAA to demonstrate the compliance with NPDES permits. Similarly, the Tracker tool is currently being developed and piloted with the City of Richmond with the express purpose of promoting scalability. The Tracker tool is coupled with the modeling and optimization tools to ensure internal consistency between the planning phase of GI implementation and the tracking and crediting phase, an important aspect to ensure high credibility.

## A.6 Virginia Phase I MS4 Permits Addressing the Chesapeake Bay TMDL

---

Through development of the Chesapeake Bay TMDL for nutrients and sediment, EPA defined target allocations of nutrient and sediment loads assigned to nineteen major river basins and six states and the District of Columbia (Bay jurisdictions). Each of the Bay jurisdictions developed a Phase I Watershed Implementation Plan (WIP) that described how the target allocations would be achieved. These WIPs included suballocations assigned to wastewater treatment facilities, urban stormwater, confined animal feeding operations, and nonpoint sources, as well as implementation strategies. EPA evaluated each WIP to determine if jurisdiction-wide and major river basin target allocations were met, adequate detail was included to ensure that NPDES permits will be developed that are consistent with the assumptions of TMDL wasteload allocations, and EPA's expectations of providing reasonable assurance<sup>8</sup> that nonpoint source reductions would be achieved and maintained. Based on the suballocations and implementation strategies identified in the WIPs, EPA performed modeling (via HSPF) using the Chesapeake Bay Watershed Model (USEPA 2010a) to evaluate if jurisdictions met target allocations and if jurisdictional allocations needed to be revised (if pollutant reductions proposed in WIPs surpassed what was identified by EPA to meet jurisdictional target allocations) (USEPA 2010b). The resulting Phase I WIPs and associated nutrient and sediment suballocations assigned MS4 permits form the basis of numeric targets to be incorporated within those permits for implementing the Chesapeake Bay TMDL.

To address the Chesapeake Bay TMDL, the Phase I WIP for the Commonwealth of Virginia (2010) identified TMDL allocations by source and river basin. Completed in 2012, the Phase II WIP provided an opportunity to refine the Phase I WIP, which included an increased commitment to a phased approach to reducing nutrients and sediment discharging from MS4s (Commonwealth of Virginia 2012). Multiple Phase I and Phase II MS4 Permits have since been issued by the Virginia Department of Environmental Quality (DEQ) that include quantitative pollution reduction requirements to address the Phase I and Phase II WIPs. These MS4 Permits include a Special Condition for the Chesapeake Bay TMDL (Special Condition) that requires MS4 operators to develop a Chesapeake Bay TMDL Action Plan (Action Plan) for submittal to DEQ. To assist MS4s in the development of Action Plans, DEQ released the Chesapeake Bay TMDL Special Condition Guidance (Guidance) to support permittees in meeting requirements of the Special Condition, create consistency in reporting to DEQ, and ensure that compliance and program evaluations are handled uniformly throughout the Commonwealth (VDEQ 2015). The Guidance states that:

“The Action Plan should provide a review of the current MS4 program, which demonstrates the permittee’s ability to ensure compliance with the Special Condition and include the means and methods the permittee will use to meet 5.0% of the Level 2 (L2) scoping run reduction for existing development by the end of the first permit cycle as well as any reductions that may be required for new sources initiating construction between July 1, 2009 and June 30, 2014 and grandfathered projects that initiate construction after July 1, 2014. Level 2 implementation equates to an average

---

<sup>8</sup> In the context of the Chesapeake Bay TMDL, “reasonable assurance” was related to sufficient WIP documentation (by states and the District of Columbia) that nonpoint source controls would be achieved and maintained and permitting programs would result in point source reductions to meet suballocations identified in each WIP (USEPA 2010b). This is not equivalent to an RAA in the context of this report, which is related to MS4 permittee demonstration of reasonable assurance that a watershed or stormwater management plan will meet MS4 permit requirements and/or numeric goals.

reduction of 9.0% of nitrogen loads, 16% of phosphorus loads, and 20% of sediment loads from impervious regulated acres and 6.0% of nitrogen loads, 7.25% of phosphorus loads and 8.75% sediment loads from pervious regulated acres beyond 2009 progress loads and beyond urban nutrient management reductions for pervious regulated acres.”

The Guidance outlines multiple steps for completing the Action Plan and methods to be used to calculate how nutrient and sediment reductions will be met. The methods prescribed are uniform for all MS4 permits including the Special Condition, and include a simple and straightforward process for permittees to follow in developing Action Plans. These steps include (VDEQ 2015):

1. **Estimate the Size and Extent of the MS4:** For development of Action Plans, the permittee must estimate the size of the MS4 system, eliminating areas regulated by separate MS4 Permits, the general permit or individual permits that address industrial stormwater, forested lands, agricultural lands, wetlands, and open waters. Permittees must clearly document the areas within their jurisdiction, and are encouraged to provide maps of MS4 boundaries, lands served by the MS4, and other lands excluded above. This step is directly related to Element 1 for an RAA.
2. **Estimate the Regulated Urban Impervious and Pervious Acres:** Permittees should use best available judgement, GIS resources, and data to estimate the acreage of regulated pervious and impervious urban areas served by the MS4 system. Permittees should document the methodology used to estimate these areas so that DEQ is able to verify an appropriate method was used. The Guidance also provides links to available aerial imagery that can support this analysis.
3. **Estimate Annual Load of Pollutants Discharged by the MS4 as of 2009:** Based on results of Step 2, permittees are to calculate 2009 nutrient and total suspended solids (TSS) loads by multiplying acreages of regulated pervious and impervious areas by corresponding unit-area loading rates (lbs/acre/year) listed in the guidance for various watersheds in Virginia. These “edge-of-field” loading rates were estimated based on previous HSPF model simulations of the Chesapeake Bay Program Watershed Model Phase 5.3.2 used to support the development of the nutrient and sediment TMDLs (USEPA 2010). Table A-4 provides an example calculation sheet and edge-of-field loading rates for urban areas within the Potomac River Basin, one of four Virginia watersheds addressed by the TMDLs. This step prescribes a simple approach to address Element 2 for an RAA.

**Table A-4. Calculation Sheet for Estimating Existing Source Loads for the Potomac River Basin (VDEQ 2015)**

Subsource	Pollutant	Total Existing Acres Served by MS4 (06/30/09)	2009 Edge-of-Field Loading Rate (lbs/acre/yr)	Estimated Pollutant Load Based on 2009 Progress Run (lbs/yr)
Regulated Urban Impervious	Nitrogen		16.86	
Regulated Urban Pervious			10.07	
Regulated Urban Impervious	Phosphorus		1.62	
Regulated Urban Pervious			0.41	

Subsource	Pollutant	Total Existing Acres Served by MS4 (06/30/09)	2009 Edge-of-Field Loading Rate (lbs/acre/yr)	Estimated Pollutant Load Based on 2009 Progress Run (lbs/yr)
Regulated Urban Impervious	Total Suspended Solids		1,171.32	
Regulated Urban Pervious			175.80	

- 4. Determine Necessary Pollutant Reductions for the First Permit Cycle:** Based on the acreage of regulated pervious and impervious areas estimated in Step 2, permittees are to calculate nutrient and sediment load reductions required within the first permit cycle. Similar to Step 3, the Guidance includes unit-area loading rates specific to required load reductions for various watersheds in Virginia. By multiplying the acreage of regulated pervious and impervious areas (estimated in Step 2) by these unit-area loading rates, a permittee can easily determine reductions required by the MS4 for the end of the permit cycle. Table A-5 provides an example sheet and pollutant reduction loading rates for the Potomac River Basin. Step 4 is the equivalent to Element 3 of an RAA.

**Table A-5. Calculation Sheet for Determining Total Pollutant Reductions Required During the Permit Cycle for the Potomac River Basin (VDEQ 2015)**

Subsource	Pollutant	Total Existing Acres Served by MS4 (06/30/09)	First Permit Cycle Required Reduction Loading Rate (lbs/acre/yr)	Total Reduction Required First Permit Cycle (lbs/yr)
Regulated Urban Impervious	Nitrogen		0.08	
Regulated Urban Pervious			0.03	
Regulated Urban Impervious	Phosphorus		0.01	
Regulated Urban Pervious			0.001	
Regulated Urban Impervious	Total Suspended Solids		11.71	
Regulated Urban Pervious			0.77	

- 5. Calculate Pollutant Reduction Credits:** To meet pollutant reductions for the current permit cycle, permittees should implement those BMPs that are included in the Virginia Stormwater BMP Clearinghouse (<http://www.vwrrc.vt.edu/swc/>) or have been approved by the Chesapeake Bay Program (Bay Program), as listed in appendices of the Guidance. Based on methods provided with the Guidance, the permittee is to demonstrate that BMPs implemented by the permittee will meet pollutant reductions determined in step 4. This is accomplished based on a two-step process including:
- a. **Calculate the pollutant load draining to a BMP:** This is accomplished based on a characterization of various land use acreages within a BMP drainage area, in

combination with unit-area loading rates assigned for urban (example provided in Table A-4), forested, and agricultural lands.

- b. Calculate BMP Credits:** The Guidance outlines methods and assumptions for calculating pollutant load reductions associated with a number of practices, including:
- Structural BMPs:
  - Land use change: Conversion factors included as
  - Urban stream restoration
  - Urban nutrient management
  - Nutrient trading
  - Redevelopment

For example, credits calculated for structural BMPs may be based on (1) BMP efficiencies reported in the Virginia Stormwater BMP Clearinghouse, or (2) retrofit performance curves provided the Bay Program. Assumptions for each approach are included within appendices of the Guidance. Table A-6 provides an example of BMP pollutant removal efficiencies established by the Bay Program and reported in the Guidance for use in calculating credits for structural BMPs.

**Table A-6. Chesapeake Bay Program BMPs, Established Efficiencies (VDEQ 2015)**

Chesapeake Bay Program BMPs	Total Nitrogen (%)	Total Phosphorus (%)	TSS (%)
Wet Ponds and Wetlands	20	45	60
Dry Detention Ponds and Hydrodynamic Structures	5	10	10
Dry Extended Detention Ponds	20	20	60
Infiltration Practices w/o Sand, Veg.	80	85	95
Infiltration Practices w/ Sand, Veg.	85	85	95
Filtering Practices	40	60	80
Bioretention C/D soils, underdrain	25	45	55
Bioretention A/B soils, underdrain	70	75	80
Bioretention A/B soils, no underdrain	80	85	90
Vegetated Open Channels C/D soils, no underdrain	10	10	50
Vegetated Open Channels A/B soils, no underdrain	45	45	70
Bioswale	70	75	80
Permeable Pavement w/o Sand, Veg. C/D soils, underdrain	10	20	55
Permeable Pavement w/o Sand, Veg. A/B soils, underdrain	45	50	70
Permeable Pavement w/o Sand, Veg. A/B soils, no underdrain	75	80	85
Permeable Pavement w/Sand, Veg. C/D soils, underdrain	20	20	55
Permeable Pavement w/Sand, Veg. A/B soils, underdrain	50	50	70
Permeable Pavement w/Sand, Veg. A/B soils, no underdrain	80	80	85

The Guidance provides a detailed and prescriptive methodology for permittees to follow to develop Action Plans. The result is an “accounting” approach to performing RAAs, utilizing (1) model

results and goals previously established through development of the Chesapeake TMDL and Phase I and II WIPs, and (2) formally approved assumptions for BMP effectiveness and crediting. The resulting Action Plans fully address Elements 1 through 4 of an RAA. However, the Action Plans provide limited information to inform cost-effective implementation and tracking of performance at meeting pollutant reduction goals (Element 5). For instance, the Guidance assumes that if the BMPs are implemented as reported in the Action Plans and meet Virginia approved stormwater BMP standards and specifications (documented by the Virginia Stormwater BMP Clearinghouse), the BMPs will meet pollutant reduction goals. However, experience has shown that BMP pollutant removal efficiencies that are often based in literature are not necessarily accurate when compared to actual implementation. Given local rainfall, soil infiltration, pollutant sources in stormwater, or considerations in BMP design, the performance can vary greatly and potentially result in an over- or under-prediction of pollutant reductions. Regardless, given that the Action Plans address the current permit cycle, and future Action Plans will address interim load reduction targets within subsequent permit cycles, a permittee will have the opportunity to continuously revisit the assumptions within past and current Action Plans. This opportunity for iterative and adaptive management can facilitate an ongoing stormwater management approach to monitor BMPs as they are implemented, benefit from lessons learned, and modify programs in the future to maximize cost-effectiveness for BMP implementation to meet load reduction goals over time.

Arlington County was the first municipality to receive a Phase I MS4 Permit (NPDES Permit No. VA0088579) that included requirements to develop an Action Plan (VDCR 2013). Located within the Potomac River Basin, the County developed an Action Plan based on Guidance assumptions for pollutant loading and reduction summarized in Table A-4 and Table A-5, respectively. The following provides a summary of the Arlington County Action Plan relative to the five basic elements of an RAA.

## **Arlington County Chesapeake Bay TMDL Action Plan**

To address the Special Condition of the Arlington County MS4 Permit, Arlington County prepared an Action Plan that documented how nutrient and sediment reductions would be achieved within the 5-year permit cycle (2013-2018) to address the Chesapeake Bay TMDL (Arlington County 2015). The Action Plan was prepared in accordance with methods outlined in the DEQ Guidance (VDEQ 2015).

**Element 1:** As allowed in the Guidance, the County estimated the physical extent of the MS4 service area. This included detailed GIS analysis to subtract areas within the County that are addressed by other permitted facilities (e.g., Virginia Department of Transportation [VDOT]), other state and federal owned land, and forested and direct drainage to streams (bypassing the MS4). For other permitted facilities, the County opted to follow a conservative approach to only subtract properties (identified in tax records) or rights-of-way boundaries (Figure A-17) (the County stated that this approach may be updated in future Action Plans). State and federal owned land (not permitted) were also identified based on tax records. The County also performed a GIS analysis of the MS4 system and topography to identify forested areas that drain directly to streams, non-forested areas that drain directly to streams and do not drain into any portion of the County MS4 (Figure A-18), and areas that have privately owned storm sewer systems that drain directly to a stream and does not drain into the County MS4 (Figure A-19). After subtracting these areas, the County MS4 service area was estimated to be 11,269.4 acres. The County performed further analysis to identify 5,201.3 acres of impervious area within this MS4 service area.

**Element 2:** Based on the estimates above for regulated pervious and impervious urban areas within the County MS4 service area (Element 1), in combination with 2009 edge-of-field loading rates (Table A-4), 2009 loads were estimated to be discharged from the MS4 for nitrogen, phosphorus, and TSS.

**Element 3:** Consistent with the Chesapeake Bay TMDL and the Phase I and II WIPs, the MS4 permit requires a 5% reduction of the pollutants of concern within the current permit cycle. As a result, a minimum 5% pollutant reduction served as the planning goal for the Action Plan. To calculate the pollutant loads to be reduced to meet this goal, the estimates of regulated pervious and impervious urban areas within the County MS4 service area (Element 1) were multiplied by first permit reduction loading rates (Table A-5).

**Element 4:** The Action Plan reported load reductions associated with watershed retrofit projects, stream restoration projects, redevelopment-based reductions, and 2006-2009 “historical BMPs.” These “in-place reductions” represent BMPs implemented and resulting pollutant reductions through 2014. Watershed retrofit projects included green streets, a municipal facility retrofitted catch basin insert systems, and one large-scale wetland project. Stream restoration projects included two completed projects, as well as two projects scheduled for completion within the current permit cycle. A number of historic BMPs were identified that included bioretention, green roofs, infiltration trenches, pavers, swales, and manufactured filters. Pollutant reductions associated with watershed retrofit projects, stream restoration projects, and historic BMPs were estimated based on methods outlined in the Guidance for pollutant removal efficiencies. An estimate was also performed for the amount of pollutant load reduced through regulated development activity that occurred in the MS4 service area from 2009 to 2014 and was subject to DEQ’s Virginia Stormwater Management Program (VSMP) Regulations and Arlington’s Stormwater Management Ordinance. A pollutant reduction credit was applied for all regulated development and redevelopment activity within the MS4 service area that disturbed at least 2,500 square feet of land. These calculations considered load changes associated with changes in land use/imperviousness, and the incorporation of BMPs. BMP load reductions were assumed based on removal efficiencies reported by the Guidance and the Virginia Stormwater Management Handbook (VDCR 2011). The Action Plan summarized the total load reductions for all practices in place (through 2014) and scheduled for implementation through the current permit cycle. The 5% load reduction was shown to be met for phosphorus and TSS with BMPs in place, with all pollutants exceeding the 5% reduction by the end of the permit cycle.

**Element 5:** The Action Plan includes multiple tables and appendices that list the BMPs in place and to be implemented and methods used for calculating load reductions. For large scale projects and stream restoration projects, maps were also provided including drainage areas. Site photographs were also provided for stream restoration projects. Limited information was provided regarding the locations and designs of BMPs included for watershed retrofit projects, although such information was not requested by DEQ.



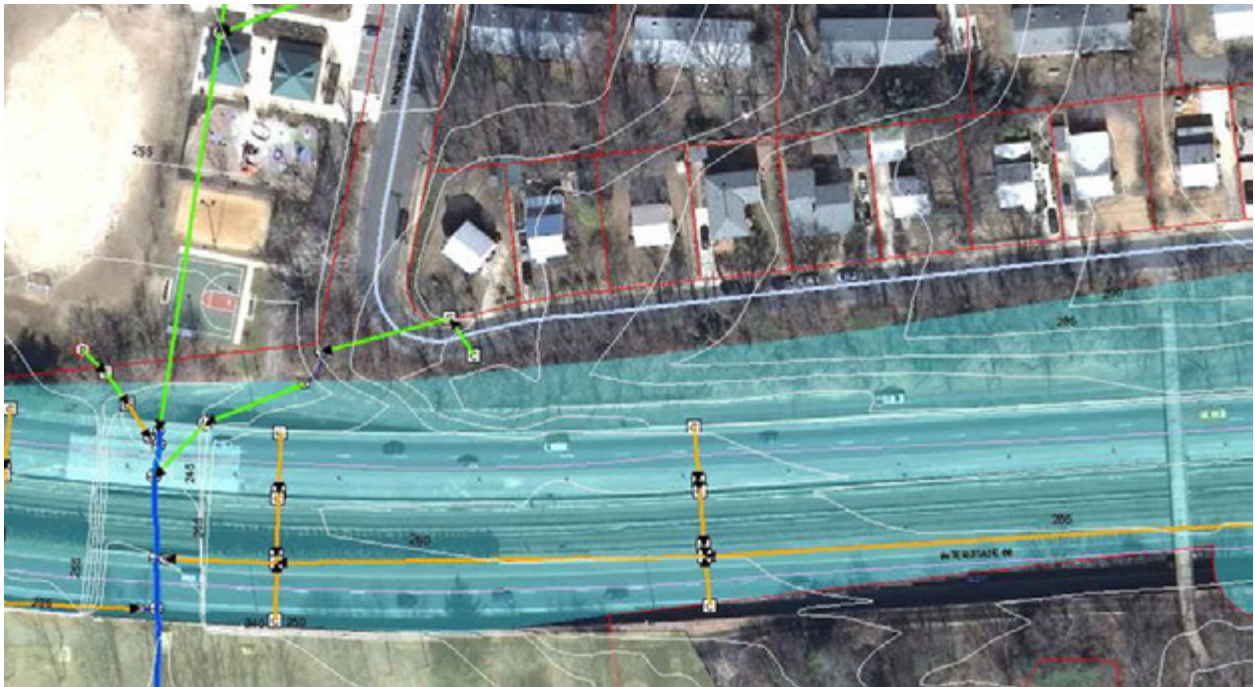

Figure A-17. Example of Non-MS4 Permitted Area – Virginia Department of Transportation (Arlington County 2015).



Figure A-18. Example of Non-MS4 Permitted Area - Forested (dark green) and Non-Forested (light green) Areas that Drain Directly to Streams (Arlington County 2015).



Figure A-19. Example of Non-MS4 Permitted Area - Privately Owned Storm Sewer System with Direct Drainage to a Stream (yellow) (Arlington County 2015)

## A.7 Massachusetts General Phase II MS4 Permits

In 2016, EPA Region 1 (New England Region) released General Permits for Stormwater Discharges from Small Municipal Separate Storm Sewer Systems in Massachusetts (General Permits), which become effective July 1, 2017. The General Permits cover three small MS4s in the Commonwealth of Massachusetts, including: traditional cities and towns (NPDES Permit No. MAR041000); State, federal, county, and other publicly owned properties (NPDES Permit No. MAR042000); and State transportation agencies (except the Massachusetts Department of Transportation – Highway Division) (NPDES Permit No. MAR043000). The General Permits include new requirements for discharges to impaired waters with approved TMDLs. For TMDLs that address phosphorus for the Charles River (MassDEP and USEPA 2007 and 2011) and sixty-six lakes and ponds (MassDEP 1999, 2001, 2002a, 2002b, 2002c, 2002d, 2002e, 2002f, 2002g, 2002h, 2003, 2006, and 2010), the General Permits include specific requirements for phosphorus reductions from MS4 discharges. Each permittee that discharges to one of these TMDL waterbodies is required to develop a Phosphorus Control Plan (PCP) for discharges to Charles River or a Lake Phosphorus Control Plan (LPCP) for discharges to lakes or ponds. The requirements for PCPs and LPCPs are similar, with defined schedules for their development (including interim schedules for completion of components and phases of the PCPs and LPCPs) and implementation of BMPs specified in the plans (with phased phosphorus reductions over time). Table A-7 summarizes the components, phases, and schedules of PCPs to address the Charles River TMDL (USEPA 2016a).

**Table A-7. PCP Phases, Components, and Schedule to Address Discharges to the Charles River (USEPA 2016a)**

Component Number	Phase 1 of the PCP Component and Milestones	Completion Date
1-1	Legal analysis	2 years after permit effective date
1-2	Funding source assessment	3 years after permit effective date
1-3	Define scope of PCP (PCP Area) baseline phosphorus load and phosphorus reduction requirement and allowable phosphorus load	3 years after permit effective date
1-4	Description of Phase 1 planned nonstructural controls	5 years after permit effective date
1-5	Description of Phase 1 planned structural controls	
1-6	Description of operation and maintenance program for structural controls	
1-7	Phase 1 implementation schedule	
1-8	Estimated cost for implementing Phase 1 of the PCP	
1-9	Complete Written Phase 1 PCP	
1-10	Full implementation of nonstructural controls	6 years after permit effective date
1-11	Performance evaluation	6, and 7 years after permit effective date
1-12	1. Performance Evaluation. 2. Full implementation of all structural controls used to demonstrate that the total phosphorus export rate ( $P_{exp}$ ) from the PCP Area in mass/yr is equal to or less than the applicable	8 years after permit effective date

Component Number	Phase 1 of the PCP Component and Milestones	Completion Date
	Allowable Phosphorus Load ( $P_{allow}$ ) plus the applicable Phosphorus Reduction Requirement (PRR) multiplied by 0.80 $P_{exp} \leq P_{allow} + (PRR \times 0.80)$	
1-13	Performance evaluation	9 years after permit effective date
1-14	1. Performance Evaluation. 2. Full implementation of all structural controls used to demonstrate that the total phosphorus export rate ( $P_{exp}$ ) from the PCP Area in mass/yr is equal to or less than the applicable Allowable Phosphorus Load ( $P_{allow}$ ) plus the applicable Phosphorus Reduction Requirement (PRR) multiplied by 0.75 $P_{exp} \leq P_{allow} + (PRR \times 0.75)$	10 years after permit effective date
Component Number	Phase 2 of the PCP Component and Milestones	Completion Date
2-1	Update legal analysis	As necessary
2-2	Description of Phase 2 planned nonstructural controls	10 years after permit effective date
2-3	Description of Phase 2 planned structural controls	
2-4	Updated description of operation and maintenance program for structural controls	
2-5	Phase 2 implementation schedule	
2-6	Estimated cost for implementing Phase 2 of the PCP	
2-7	Complete written Phase 2 Plan	
2-8	Performance evaluation	11, and 12 years after permit effective date
2-9	1. Performance Evaluation. 2. Full implementation of all structural controls used to demonstrate that the total phosphorus export rate ( $P_{exp}$ ) from the PCP Area in mass/yr is equal to or less than the applicable Allowable Phosphorus Load ( $P_{allow}$ ) plus the applicable Phosphorus Reduction Requirement (PRR) multiplied by 0.65 $P_{exp} \leq P_{allow} + (PRR \times 0.65)$	13 years after permit effective date
2-10	Performance evaluation	14 years after permit effective date
2-11	1. Performance Evaluation. 2. Full implementation of all structural controls used to demonstrate that the total phosphorus export rate ( $P_{exp}$ ) from the PCP Area in mass/yr is equal to or less than the applicable Allowable Phosphorus Load ( $P_{allow}$ ) plus the applicable Phosphorus Reduction Requirement (PRR) multiplied by 0.50 $P_{exp} \leq P_{allow} + (PRR \times 0.50)$	15 years after permit effective date
Component Number	Phase 3 of the PCP Component and Milestones	Completion Date
3-1	Update legal analysis	As necessary
3-2	Description of Phase 3 planned nonstructural controls	
3-3	Description of Phase 3 planned structural controls	

Component Number	Phase 1 of the PCP Component and Milestones	Completion Date
3-4	Updated description of operation and maintenance program for structural controls	15 years after permit effective date
3-5	Phase 3 implementation schedule	
3-6	Estimated cost for implementing Phase 3 of the PCP	
3-7	Complete written Phase 3 Plan	
3-8	Performance evaluation	16, and 17 years after permit effective date
3-9	1. Performance Evaluation. 2. Full implementation of all structural controls used to demonstrate that the total phosphorus export rate ( $P_{exp}$ ) from the PCP Area in mass/yr is equal to or less than the applicable Allowable Phosphorus Load ( $P_{allow}$ ) plus the applicable Phosphorus Reduction Requirement (PRR) multiplied by 0.30 $P_{exp} \leq P_{allow} + (PRR \times 0.30)$	18 years after permit effective date
3-10	Performance evaluation	19 years after permit effective date
3-11	1. Performance Evaluation. 2. Full implementation of all structural controls used to demonstrate that the total phosphorus export rate ( $P_{exp}$ ) from the PCP Area in mass/yr is equal to or less than the applicable Allowable Phosphorus Load ( $P_{allow}$ ) $P_{exp} \leq P_{allow}$	20 years after permit effective date

The General Permits provide detailed descriptions of each of the components of PCPs (Table A-7) and LPCPs, as well as processes and instructions to follow for their development. A number of the PCP/LPCP components align directly with the five RAA elements. For example, Component 1-3 for Phase I of the PCP (Table A-7) directly addresses Element 1 for an RAA (Designation of Area Addressed by Analysis). To perform Component 1-3 of the PCP, the General Permit states that (USEPA 2016a):

“The permittee shall indicate the area in which it plans to implement the PCP. The permittee must choose one of the following: (1) to implement its PCP in the entire area within its jurisdiction (for municipalities this would be the municipal boundary) within the Charles River Watershed; or (2) to implement its PCP only in the urbanized area portion of the permittee’s jurisdiction within the Charles River Watershed. The implementation area selected by the permittee is known as the “PCP Area” for that permittee.”

Component 1-3 also addresses Element 2 (Characterization of Existing Conditions) and Element 3 (Determination of Stormwater Improvement Goals) for an RAA. The General Permits include tables designating phosphorus load reduction requirements for each permittee with MS4 discharges to Charles River or lakes and ponds addressed by the TMDLs. These load reduction requirements vary depending on the option selected by each permittee to designate the PMP Area. For example, for a subset of permittees (Bellingham, Franklin, and Milford) in the Charles River watershed that select option 2 for designation of the PCP area (confined to the urbanized area portion of the permittee’s jurisdiction), the General Permits specify the baseline phosphorus load, phosphorus

reduction requirement (load reduced and percent reduction), and allowable phosphorus load (Table A-8 ) to be uses for their PCPs. These loading rates are based on methods used in development of the Charles River TMDL for phosphorus (MassDEP and USEPA 2011B), with further refinements for incorporation in the General Permits to account for: (1) revised hydrologic soil groups, and (2) phosphorus reductions assumed to result from proper use of fertilizers and turf grasses in accordance with Massachusetts Regulation (USEPA 2016b). Based on these loading rates, a permittee can characterize phosphorus loadings associated with existing conditions (Element 2), and determine phosphorus reductions associated with stormwater (Element 3) to set planning goals for the PCP. It should be noted that the phosphorus loads reported in the General Permits are based on land use data from 2005, which was the year chosen as the baseline land use for the permit. Permittees can develop updated assumptions and maps for land uses in their jurisdiction and submit the information in their annual report for year four of the permit. This information can then be used to update phosphorus loads for permittees in future permits (USEPA 2016a).

**Table A-8. Phosphorus Baseline Load, Reduction Requirement, Allowable Load, and Percent Reduction for Selected Permittees in the Charles River Watershed (USEPA 2016a)**

Community	Baseline Phosphorus Load (kg/yr)	Stormwater Phosphorus Load Reduction Requirement (kg/yr)	Allowable Phosphorus Load (kg/yr)	Stormwater Percent Reduction in Phosphorus Load (%)
Bellingham	947	331	616	35%
Franklin	2,344	818	1,526	35%
Milford	1,486	653	833	44%

The Performance Evaluations associated with Phase 1 Component 1-11 through 1-14, Phase 2 Component 2-8 through 2-11, and Phase 3 Component 3-8 through 3-11 (Table A-7) provide the equivalent to Element 4 for an RAA (Demonstration that Management Actions will Result in Attainment of Goals). The General Permits outline processes for performing evaluations of the effectiveness of the PCP and phosphorus load reductions achieved through the implementation of structural and non-structural BMPs and tracking increases of phosphorus loads resulting from development. For non-structural BMPs, the General Permits provides easy-to-use equations for calculating load reduction “credits” associated with enhanced street sweeping programs, catch basin cleaning, and organic waste and leaf litter collection programs. As an example, the equation for calculating phosphorus load reduction credits for street sweeping program is as follows (USEPA 2016a):

$$\text{Credit}_{\text{sweeping}} = \text{IA}_{\text{swept}} \times \text{PLE}_{\text{IC-land use}} \times \text{PRF}_{\text{sweeping}} \times \text{AF}$$

where:

- Credit<sub>sweeping</sub> = Amount of phosphorus load removed by enhanced sweeping program (lb/year),
- IA<sub>swept</sub> = Area of impervious surface that is swept under the enhanced sweeping program (acres),
- PLE<sub>IC-land use</sub> = Phosphorus Load Export Rate for impervious cover and specified land use (lb/acre/yr) (provided in table in the General Permits),

AF = Annual Frequency of sweeping. For example, if sweeping does not occur in Dec/Jan/Feb, the AF would be 9 mo./12 mo. = 0.75. For year-round sweeping, AF=1.0.

The General Permits also includes a detailed methodology for permittees to use to determine design storm volume capacities and to calculate phosphorus load reductions for a number of structural stormwater BMPs (e.g., infiltration basin, bio-filtration practice, porous pavement, wet or dry ponds) and semi-structural/non-structural BMPs (e.g., impervious area disconnection, conversion of impervious area to permeable pervious area). The assumptions associated with this methodology have evolved over years of research performed by EPA Region 1 on the effectiveness of these BMPs at reducing phosphorus loads. For instance, EPA Region 1 performed modeling to estimate the long-term cumulative efficiencies of several types of BMPs based on their size and other design considerations. This modeling utilized typical designs for several types of structural BMPs developed by the Massachusetts Department of Environmental Protection (MassDEP) (2008). An example typical design of a water quality swale is shown in Figure A-20. This modeling, based on EPA's Storm Water Management Model (SWMM) (Huber and Dickenson 1988) and a BMP Decision Support System (BMPDSS) (Prince George's County 2005a, 2005b, and 2007), was used to provide:

1. Selection of appropriate long-term rainfall record (data and location) that is representative of major urbanized areas within the New England region.
2. Simulation of hydrograph and pollutant time series using a land-based hydrologic and water quality model.
3. Simulation of BMP hydraulic and treatment processes in BMP models.
4. Creation of BMP performance curves on the basis of BMP model simulation results.

The modeling included extensive calibration based on local monitoring data to ensure that results were representative of hydrology, pollutant loading, and BMP performance observed within the New England region (USEPA 2010c). The resulting BMP performance curves and companion tables for long-term phosphorus and runoff volume reduction were included within the General Permits to support the methodology for PCP performance evaluations. An example BMP performance curve reported in the General Permits for an infiltration trench (with a soil infiltration rate of 0.17 in/hr) is shown in Figure A-21. These curves provide permittees access to BMP performance estimates that are based on modeling and tailored to conditions and characteristics of the New England region. Based on estimates of land use and imperviousness within a BMP drainage area, a permittee can use phosphorus export rates (lbs/acre/year) reported in the General Permits to estimate the phosphorus loading to a planned BMP. The permittee can use the BMP performance curves to determine the pollutant removal associated with a planned BMP, or size the BMP to meet a phosphorus reduction target (USEPA 2016a).

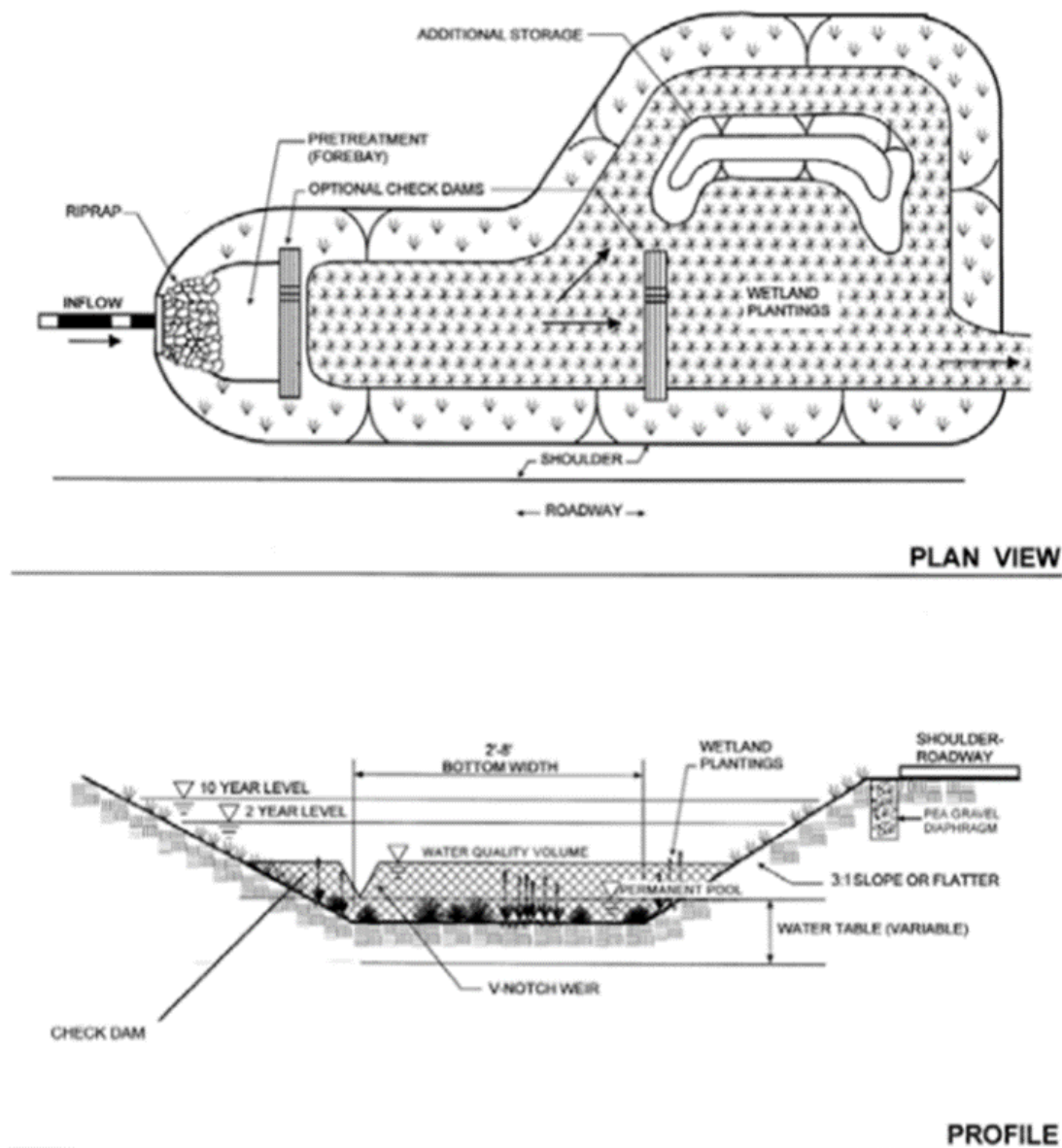

Figure A-20. Typical Design for a Water Quality Swale (MassDEP 2008)

To further assist permittees in the development of PCPs and the planning of BMPs, EPA Region 1 has developed multiple tools to calculate the phosphorus load reductions associated with various structural and nonstructural BMPs. For example, prior to release of the General Permits, EPA Region 1 developed the BMP Performance Extrapolation Tool (BMP-PET). The BMP-PET allowed a user to enter information on drainage area and BMP characteristics, and the tool accessed the previously developed BMP performance curves to estimate pollutant removal efficiency or runoff volume reduction. Alternatively, a user could enter a target BMP removal efficiency and BMP-PET would estimate the corresponding required BMP size and runoff volume reduction to meet the target (USEPA 2011b). After release of the General Permits, EPA Region 1 developed the BMP Accounting and Tracking Tool (BATT), which builds off of BMP-PET to provide tracking of structural BMP performance in terms of phosphorus reduction (based on BMP performance curves),



with added capability to estimate phosphorus load reductions associated with nonstructural BMPs and land use conversion (consistent with methods outlined in the General Permits) and generate reports that summarize all implementation activities for a permittee (Figure A-22). The BATT reduces the burden on permittees in interpreting the methods outlined in the General Permits (e.g., BMP performance curves, equations associated with nonstructural BMPs), providing efficiency in BMP tracking, performance evaluations, and reporting associated with PCPs (USEPA 2016c).

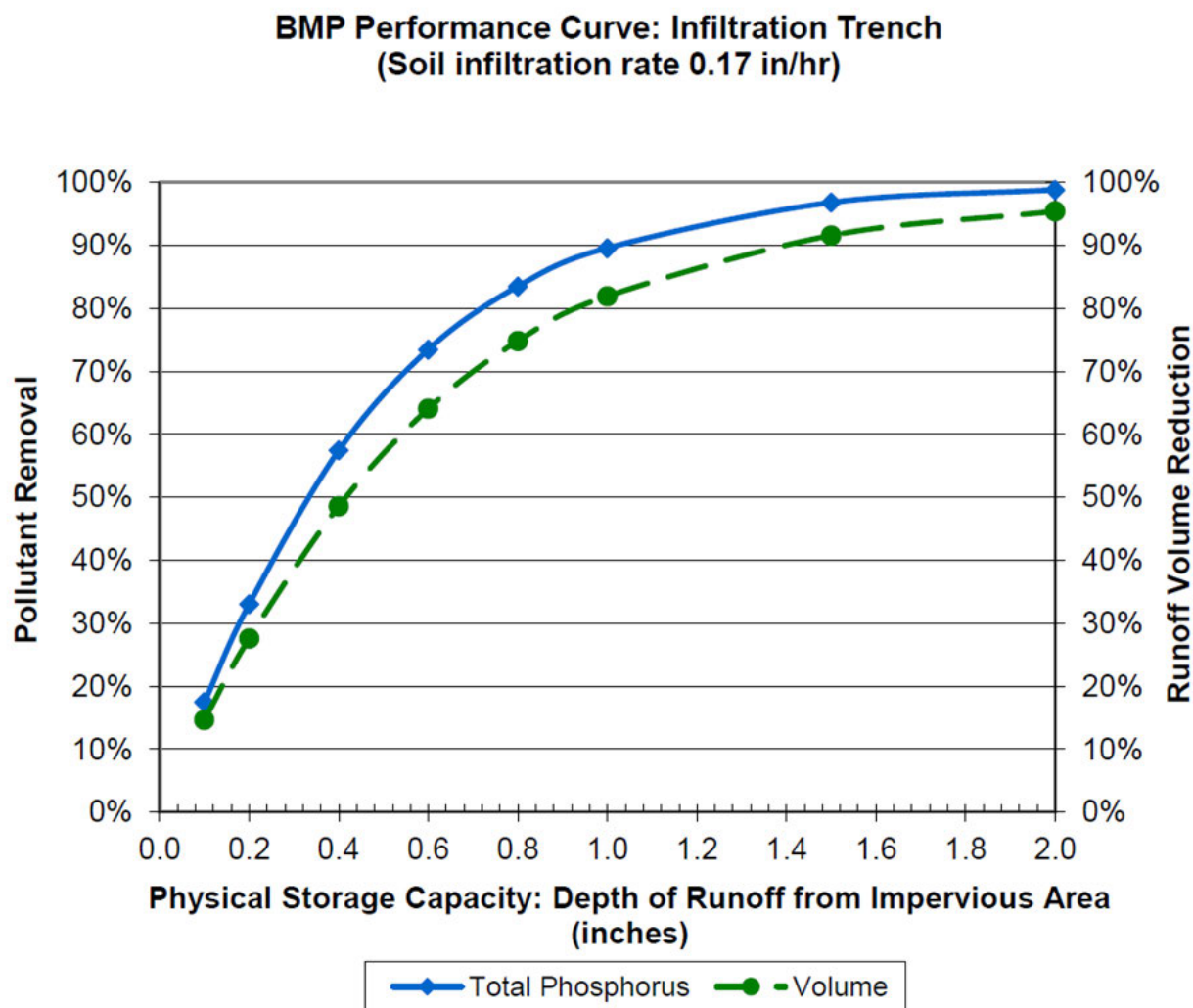

Figure A-21. BMP Performance Curve: Infiltration Trench (USEPA 2016a).

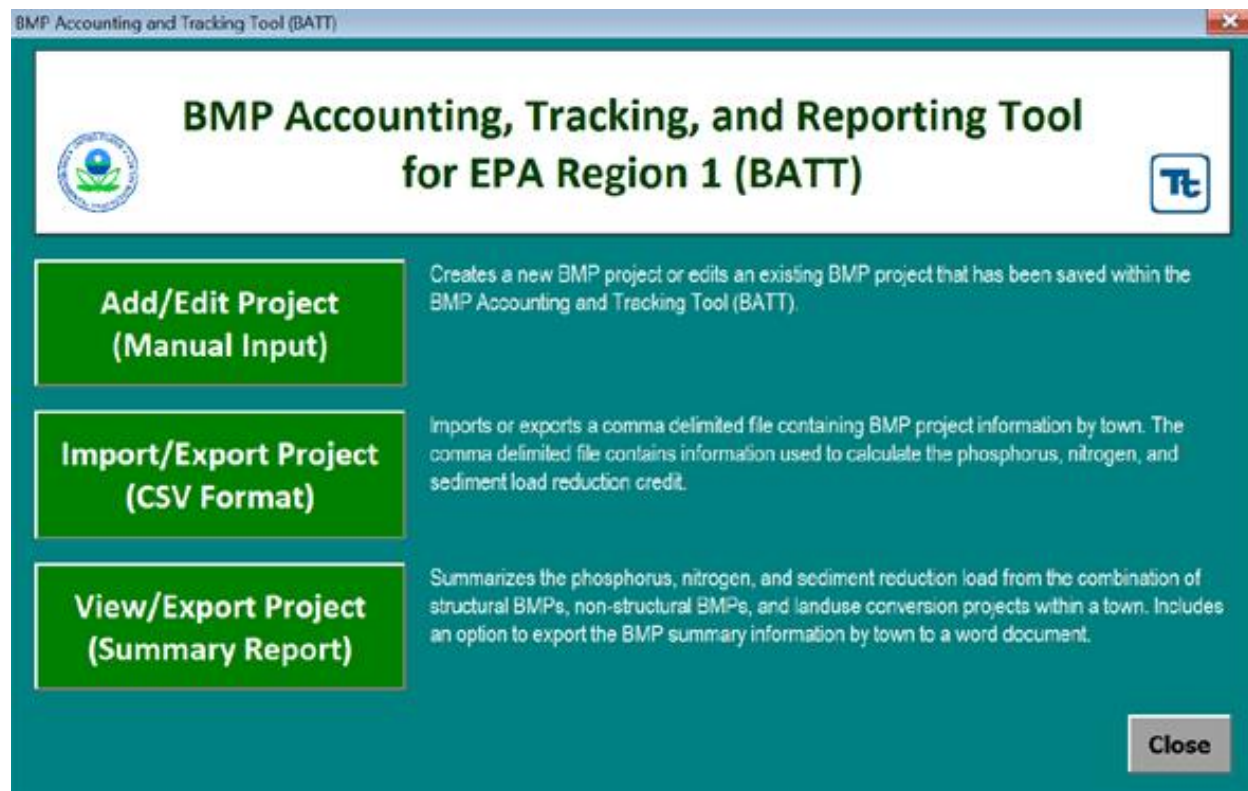

Figure A-22. User Interface for BATT (USEPA 2016c).

To further support permittee efforts to prepare PCPs, EPA Region 1 also developed case studies to serve as examples for using modeling and cost-optimization techniques for the planning of BMPs, assessing potential costs for meeting phosphorus reductions through stormwater management, and the feasibility of establishing funding sources to support the needed stormwater management. Prior to release of the General Permits and in anticipation of the new requirements for PCPs, EPA Region 1 developed an initial case study applied to three communities in the Upper Charles River watershed subject to the nutrient TMDL: Bellingham, Franklin, and Milford (Table A-8) (MassDEP and USEPA 2011B, USEPA and MassDEP 2009). As no PCPs have been completed at the time of this investigation, no case study could be included within this report to demonstrate methods used by a permittee to meet requirements of the General Permits. However, additional discussion of the EPA Region 1 case study and its relevance to the five elements of an RAA are provided in the following example. It is anticipated that PCPs will have similarities to this case study, however, optimization is not a required component of PCPs. Regardless, EPA Region 1 has recognized that it will likely be in a permittee's interest to utilize optimization techniques to assist in the planning of BMPs to be incorporated within PCPs, and provide assurance that those BMPs are most cost-effective at meeting phased phosphorus load reduction targets over time. To further support permittee efforts in developing PCPs, EPA Region 1 has developed a spreadsheet tool that utilizes BMP performance curves included within the General Permits, as well as optimization techniques available within EPA's SUSTAIN, to provide an easy-to-use methodology to assist in developing technically sound, cost-effective PCPs. Released in 2016, this "Opti-Tool" is available as a public-domain tool for all permittees and other agencies in the New England region to support PCPs and stormwater planning efforts (USEPA 2016d and 2016e).

EPA Region 1 supported an additional case study to assess: (1) the potential cost of meeting TMDL phosphorus reduction targets through public and private sector stormwater management, (2) the

feasibility of establishing a funding sources to serve the three example communities previously investigated for cost-effective BMP planning (Bellingham, Franklin, and Milford) (USEPA 2011B). Findings from this case study informed development of the General Permits, and provides a useful reference for permittees to support selection of cost-effective BMPs and the Funding Source Assessment component of the PCP (Phase I, Component 1-2) (Table A-7).

## **Optimal Stormwater Management Plan Alternatives: A Demonstration Project in Three Upper Charles River Communities**

Prior to the release of the General Permits and the associated requirements for PCPs, EPA Region 1 performed a study to provide a demonstration and guide to communities in the implementation of the phosphorus TMDL for the Upper Charles River (MassDEP and USEPA 2011). The objectives of the study included development of optimized, planning-level-scale stormwater management alternatives for the communities of Bellingham, Franklin, and Milford, MA. Models used to support the analysis included EPA's SWMM for simulation of stormwater and phosphorus loads, and BMPDSS for simulation of BMP phosphorus reductions and cost-optimization for BMP selection (USEPA 2009b, MassDEP 2009).

**Element 1:** The study included a comprehensive GIS analysis to identify urban and nonurban land uses, pervious/impervious areas, and hydrologic soil groups within each community jurisdiction. The resulting combination of land characteristics led to the development of unique hydrologic response units (HRUs) to support pollutant loading analysis and selection of BMPs to treat runoff. The HRUs allowed the modeling and pollutant reduction analysis to focus on urban areas within each community.

**Element 2:** Based on land use and pervious/impervious areas identified in Element 1, phosphorus unit-area loading rates (kg/ha/yr) were applied to calculate annual average phosphorus loadings from each community to the Upper Charles River. SWMM was used to provide ten-year, hourly simulation of phosphorus loads for each HRU, with calibration of SWMM buildup and washoff parameters performed to closely match annual loading estimates based on unit-area loading rates. As a result, SWMM could be applied to represent existing phosphorus loading conditions within each proposed BMP drainage area, based on the combinations of HRUs within those areas.

**Element 3:** Phosphorus reduction targets for the three communities were based on TMDL reduction targets (MassDEP and USEPA 2011), prior to adjustment of those targets during preparation of the General Permits (Table A-8) (USEPA 2016a and 2016b). As a result, reduction targets used in the study for Bellingham, Franklin, and Milford were assumed to be 52%, 52%, and 57%, respectively. It should be noted that future PCPs developed for these communities will based reductions on those summarized in Table A-8, as reported in the General Permits.

**Element 4:** The study assigned different combinations of BMPs based on 28 management categories that aggregated areas sharing similar site conditions and suitability for implementing the same type of BMPs. All BMP site condition requirements and design assumptions were consistent with the Massachusetts Stormwater Handbook (MassDEP 2008). Figure A-20 shows an example typical design for a water quality swale modeled in the study. Three model scenarios were investigated that considered runoff from impervious or pervious HRUs (modeled by SWMM), routed to a system of BMPs for the different management categories (modeled by BMPDSS), with untreated runoff and overflow from BMPs routed to outlets for the communities (Figure A-23). These scenarios included: (1) runoff from only impervious HRUs within parcels is routed to BMPs; (2) consistent with scenario 1, except impervious runoff from the public right-of-way parcels is treated at downstream centralized facilities (neighborhood BMPs identified with input from the communities); and (3) consistent with scenario 2, except impervious and pervious runoff from non-public right-of-way parcels is treated by onsite BMPs. An example model configuration of scenario 1 is depicted in Figure A-23. The goal of the optimization was to identify the most cost-effective configuration of BMPs for each scenario to meet TMDL phosphorus load reductions identified in Element 3. BMPDSS provided simulation of thousands of alternative BMP configurations for each of the three scenarios and predicted associated phosphorus load reductions and BMP implementation costs. These BMPDSS results were plotted to demonstrate increasing phosphorus reductions verses costs, from which a cost-effectiveness curve can be investigated to identify the most cost-effective solution. Figure A-24 provides an example of optimization results for scenario 1 in Bellingham.

**Element 5:** The study presented results of the modeling and optimization in various forms, ranging from summaries of impervious area treated with BMPs and associated total costs, costs per acre, and costs per pound of phosphorus removed, to more detailed tabulation of the different types of BMPs and associated level of treatment (area of BMP and runoff depth treated) within key urban and non-urban land use areas.

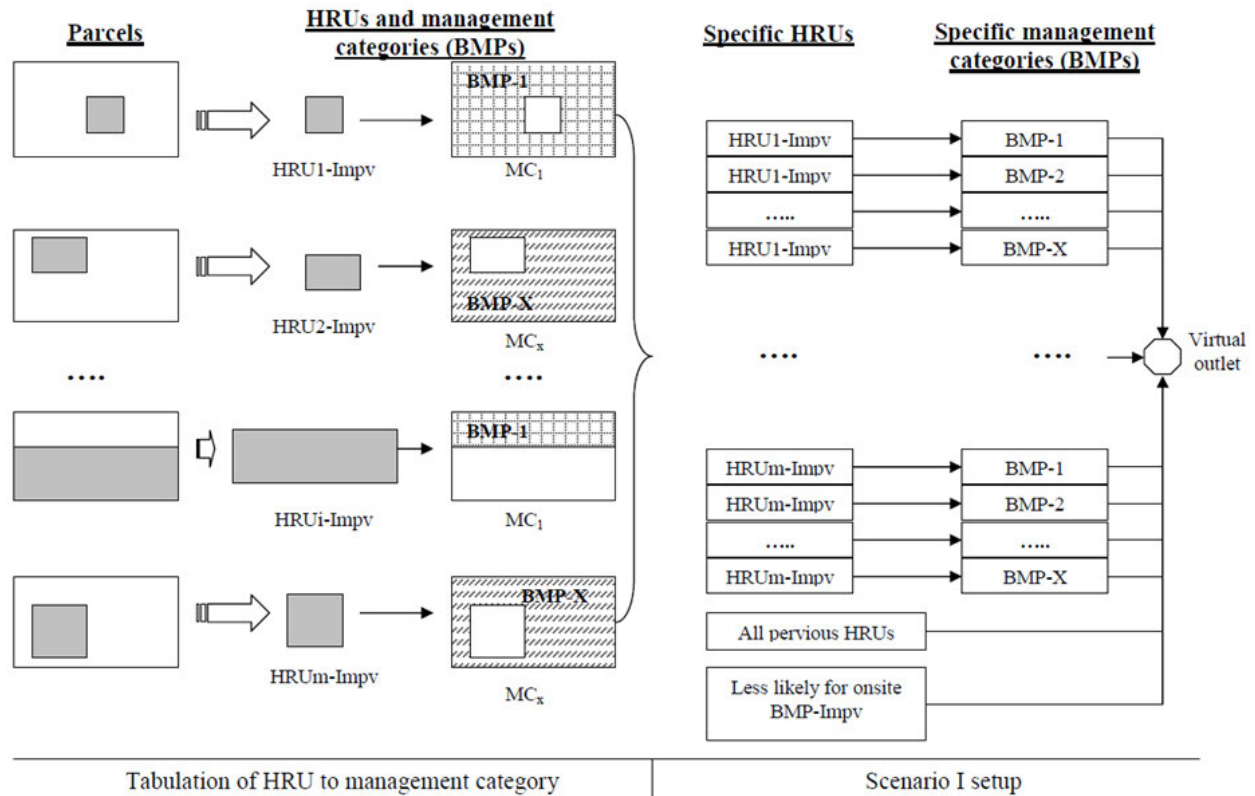

Figure A-23. Example Model Configuration for a Combination of HRUs and Management Categories in Upper Charles River Communities (USEPA and MassDEP 2009).

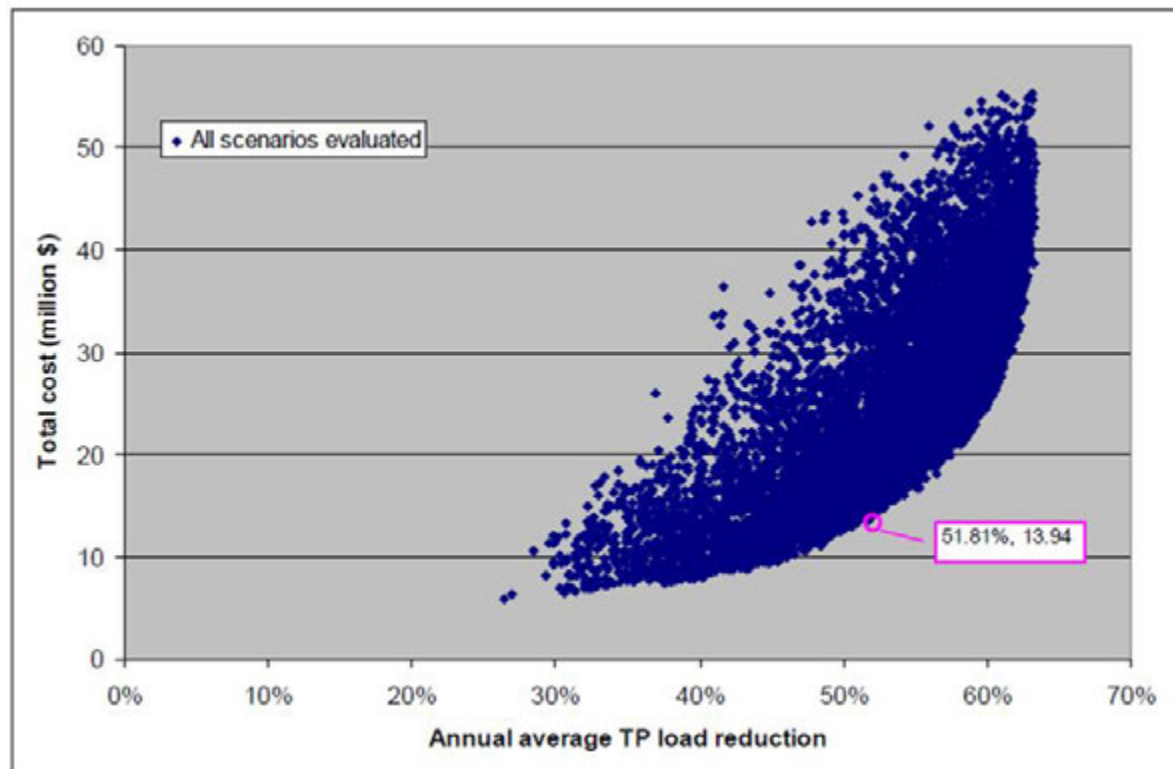

Figure A-24. BMPDSS Optimization Results for Bellingham, MA (Scenario 1) (USEPA and MassDEP 2009).