

Norfolk Southern Railway Company

Groundwater Characterization Work Plan

**East Palestine Train Derailment
Columbiana County, Ohio**

June 27, 2023

We are in the process of ensuring this document is accessible to all audiences. If you need assistance accessing this document, or any material on the EPA East Palestine, Ohio emergency response web pages, please contact the Region 5 Public Information Officer on-call at: R5_EastPalestine@epa.gov

Attorney-Client Privilege
Attorney Work Product/Prepared at the Direction of Counsel
Groundwater Characterization Work Plan

Groundwater Characterization Work Plan

East Palestine Train Derailment
Columbiana County, Ohio

June 27, 2023

Prepared By:

Arcadis U.S., Inc.
7575 Huntington Park Drive, Suite 130
Columbus
Ohio 43235
Phone: 614 985 9100
Fax: 614 985 9170

Prepared For:

Mr. Daniel Hunt
Regional Manager Environmental Remediation
Norfolk Southern Railway Company

Our Ref:

30169714

This document is intended only for the use of the individual or entity for which it was prepared and may contain information that is privileged, confidential and exempt from disclosure under applicable law. Any dissemination, distribution or copying of this document is strictly prohibited.

Version Control

Revision No.	Date Issued	Description
1.0	March 5, 2023	Initial submittal
2.0	May 19, 2023	Second Submittal Update of document based on 4/18/203 comments
3.0	May 26, 2023	Third Submittal Update of document based on 5/24/2023 comments
4.0	June 20, 2023	Fourth Submittal Update of documents based on June 8, 2023 comments
4.1	June 23, 2023	Updates based on June 22, 2023 comments
4.2	June 27, 2023	Updates based on June 26, 2023 comments

This document is intended only for the use of the individual or entity for which it was prepared and may contain information that is privileged, confidential and exempt from disclosure under applicable law. Any dissemination, distribution or copying of this document is strictly prohibited.

Contents

Acronyms and Abbreviations.....	iv
1 Introduction.....	1
1.1 Site Background and History	1
1.2 Geology and Hydrogeology.....	2
2 Purpose and Scope	4
3 Groundwater Characterization	9
3.1 Data Quality Objectives.....	9
3.2 Objectives.....	9
3.3 Methods	10
3.3.1 Field Procedures.....	10
3.3.1.1 Field Documentation	10
3.3.1.2 Sample Chain of Custody	10
3.3.1.3 Sample Nomenclature	11
3.3.1.4 Equipment Decontamination.....	11
3.3.2 Soil Coring and Logging.....	12
3.3.3 Soil Sampling	12
3.3.4 Shallow Monitoring Well Installation	13
3.3.5 Permanent Well Installation and Surveying.....	13
3.3.6 Well Development.....	14
3.3.7 Water Level Measurements	15
3.3.8 Groundwater Sampling	15
3.3.9 Aquifer Testing via Slug Tests	17
3.3.10 Investigation Derived Waste.....	18
3.4 Proposed Locations	18
4 Laboratory Methods and QA/QC.....	20
4.1 Analytical Parameters and Screening Levels.....	20
5 Data Review and Decision Statements.....	24
6 Reporting and Schedule	26
7 References.	27

Tables

Table 2.1	Guidance Documents – FSOPs, Technical Guidance Instructions (TGIs), and TGMs	5
Table 3-1	Incident Area Well Construction Details	Error! Bookmark not defined.
Table 3-1	Well Development Stabilization Criteria	14
Table 3-2	Groundwater Sampling Stabilization Criteria	16
Table 4-1	Constituents of Concern and Screening Levels.....	20
Table 5-1	Decision Statements.....	24

Figures

Figure 4-1 Proposed Sample Locations

Appendices

Appendix A	Technical Guidance Instructions and Field Standard Operating Procedures
Appendix B	PFAS Field Sampling Guide
Appendix C	Soil Boring and Construction Logs; Stantec Preliminary Potentiometric Surface Map

Acronyms and Abbreviations

°C	degrees Celsius
°F	degrees Fahrenheit
%	percent
AFFF	aqueous filming foam
amsl	above mean sea level
Arcadis	Arcadis U.S., Inc.
Bgs	below ground surface
COC	Chain of Custody
CSM	Conceptual Site Model
CWH	Coldwater Habitat
DDAGW	Division of Drinking and Ground Water

Attorney-Client Privilege

Attorney Work Product/Prepared at the Direction of Counsel

Groundwater Characterization Work Plan

DERR	Division of Environmental Response and Revitalization
DO	Dissolved Oxygen
DPT	Direct Push Technology
eV	electron volt
EWH	Exceptional Warmwater Habitat
FSOPs	Field Standard Operations Procedures
ft	feet
GPS	Global Positioning System
HASP	Health and Safety Plan
HSA	Hollow Stem Auger
IDW	Investigation Derived Waste
in/yr	inches per year
No.	number
NOAA	National Atmospheric and Atmospheric Administration
NTU	Nephelometric Turbidity Units
NSRC	Norfolk Southern Railway Company
OEPA	Ohio Environmental Protection Division
ORP	Oxidation Reduction Potential
PFAS	Per and Perfluorinated Alkyl Substances
Plan	Groundwater Characterization Work Plan
PPE	personal protective equipment
PVC	polyvinyl chloride
mg/L	milligrams per liter
mL/min	milliliters per minute
mV	millivolts
QAPP	Quality Assurance Project Plan
QA/QC	quality assurance/quality control
S.U.	Standard Units
SESD	Science and Ecosystem Support Division
Stantec	Stantec Consulting Services, Inc.
SVOC	semi-volatile organic carbon
TGI	Technical Guidance Instruction
TGM	Technical Guidance Manual

Attorney-Client Privilege
Attorney Work Product/Prepared at the Direction of Counsel
Groundwater Characterization Work Plan

UAO	Unilateral Administrative Order for Removal Actions
USEPA	United States Environmental Protection Agency
VI	vapor intrusion
VOC	volatile organic carbon
WWH	Warmwater Habitat

1 Introduction

This Groundwater Characterization Work Plan (Plan) was developed on behalf of Norfolk Southern Railway Company (NSRC) by Arcadis US, Inc. (Arcadis) in response to the derailment in East Palestine, Ohio, and pursuant to the United States Environmental Protection Agency (USEPA) February 21, 2023 Unilateral Administrative Order for Removal Actions (UAO), which became effective on February 27, 2023. This Plan outlines the objectives and procedures for groundwater characterization activities in the vicinity of the derailment.

This Plan was initially submitted in draft form on March 5, 2023 and included a limited scope of work involving the installation and sampling of 10 monitoring wells in the vicinity of the derailment area. Since this time, four of the 10 wells have been installed and sampled and, via information derived from the soil exploration and excavation work, it has become clear that a shallow perched groundwater system is present and warrants further investigation. The Plan submitted here within includes a more comprehensive Conceptual Site Model (CSM) along with provisions for investigating this perched groundwater system, shallow soils and the continuation of the investigation of the deeper aquifer.

As part of a larger group of plans collectively making up the project Removal Work Plan, the work described in this Plan will be conducted in accordance with the Quality Assurance Project Plan (QAPP), Health and Safety Plan (HASP), and other overall documents that provide procedures for sample collection, identification, and analysis. Media-specific sampling and analysis procedures are presented below to support the scope of work discussed herein.

"Unified Command" in this Plan refers to the incident management structure established by USEPA under the UAO and the Incident Command System. The Unified Command team includes USEPA incident managers as well as representatives from state and federal agencies such as the Ohio Environmental Protection Agency and the Pennsylvania Department of Environmental Protection. As described in this Plan, Unified Command will work collaboratively to review characterization and remediation decisions.

1.1 Site Background and History

East Palestine is a village in the northeastern portion of Columbiana County, Ohio. The village is located on the Ohio state border with Pennsylvania and is about 20 miles south of Youngstown, Ohio, and 40 miles northwest of Pittsburgh, Pennsylvania and has approximately 5,000 residents.

On February 3, 2023, a derailment occurred near the North Pleasant Drive crossing in East Palestine, Columbiana County, Ohio. The derailment involved 51 rail cars and resulted in a fire and breaches to tank cars that contained hazardous materials (i.e., vinyl chloride, butyl acrylate, ethylene glycol monobutyl ether, and ethylhexyl acrylate) and non-hazardous materials. The release of hazardous materials from the damaged cars affected soil and surface water in the area of the derailment.

NSRC immediately mobilized response personnel to the incident. On February 6, 2023, the vent and burn method was used to address hazards posed by five unstable vinyl chloride rail cars. This action was carried out in conjunction with a mandatory evacuation of local residents from a 1-mile radius of the site. After confirming via air monitoring that COPCs were not present in the air at levels of concern, the evacuation order was lifted on February 8, 2023, and rail operations resumed.

Attorney-Client Privilege

Attorney Work Product/Prepared at the Direction of Counsel

Groundwater Characterization Work Plan

Both the emergency response efforts conducted immediately after the derailment to stop, contain, and recover COPCs released to the environment and the continuing response activities have been designed to limit opportunities for secondary migration. These activities – which are either completed or ongoing – include:

- Collecting free/pooled liquids
- Excavating impacted soil and ballast
- Removing rail cars and debris
- Rerouting surface water flow to bypass the derailment location
- Constructing underflow dams to control/collect floating separate-phase liquids
- Constructing an interceptor trench to collect separate-phase liquids
- Treating surface water via aeration and activated carbon to promote removal of released COPCs
- Cleaning storm sewers
- Monitoring and sampling across various media (surface water, sediment, air, soil, potable water, and groundwater)

Response crews continue operations to stop, contain, and recover the releases. That work is ongoing and has expanded to include efforts to assess the nature and extent of potential impacts and conduct certain additional removal activities to protect human health and the environment.

The following work has been completed by Arcadis as part of the groundwater characterization:

- Installation of monitoring wells MW-03, MW-06, MW-08 and MW-10 in early March 2023.
- Weekly sampling of monitoring wells MW-03, MW-06, MW-08 and MW-10 has been conducted since March 18, 2023.

1.2 Geology and Hydrogeology

East Palestine is located in the northeast portion of Columbiana County within the Glaciated Allegheny Plateau section of the Appalachian Plateau physiographic province, the Glaciated Allegheny Plateau extends into a belt of southern New York State and the central Susquehanna River basin. Glaciation in the region resulted from southward expansion of ice in the Grand River sublobe to the Erie lobe. Several ice sheets invaded the area during the late Wisconsin Glaciation Stage during the Holocene and an unknown number of advances occurred during earlier Pleistocene time (White, 1961). The area is characterized by ridges and flat uplands generally above 1,200 ft, covered with thin drift and dissected by steep valleys; valley segments alternate between broad drift-filled and narrow rock-walled reaches. These areas are underlain by varying thicknesses of Holocene Wisconsin-age ice-contact deposits and numerous buried valleys, consisting of poorly sorted gravel and sand with inclusions of silt, clay, and till lenses and are directly from stagnant ice as kame or esker landforms (White and Totten, 1985).

Bedrock in this region consists of Pennsylvanian-age Pottsville and Allegheny groups comprising of shales, sandstones, conglomerates, and coals (Brockman, 1998). It is common to see Allegheny units exposed at the tops of ridges, overlying Pottsville rocks. Rocks of the Pottsville and Allegheny groups present in the region were primarily deposited in a shallow marine environment, which was transitional with a terrigenous environment over time. Sandstone within the bedrock is medium to coarse grained, nonbedded to massive with abundant rounded quartz-pebbles and quartz-pebble conglomerate present in the basal portion. Interbeds of shale, coal, siltstone,

Attorney-Client Privilege
Attorney Work Product/Prepared at the Direction of Counsel
Groundwater Characterization Work Plan

limestone, and clay are common in the upper portions. Strata are generally flat-lying and dip towards the south and east (Angle, 1994).

The local geology at the East Palestine derailment site is consistent with the glacial ice-contact deposits and buried valleys bound below and laterally by Pennsylvanian age Pottsville and Allegheny group interbedded sandstones and shale. The upper 10-15 ft below ground surface (bgs) consists of poorly sorted fill, gravel, and sand with inclusions of silt and clay. A fine-grained floodplain till deposit comprised of clay interbedded with silty sand has been encountered from the 10-15 ft bgs to 45 ft bgs interval at the site. Below the clay confining unit is a permeable sand and gravel kame/outwash deposit which is utilized to supply the community of East Palestine with drinking water that is approximately 36 ft thick (OEPA, 2002).

All of Columbiana County is eventually drained into the Ohio River watershed. East Palestine is drained by tributaries Sulphur Run and Leslie Run. These creeks flow into North Fork Little Beaver Creek, which flows southwest to Little Beaver Creek, and finally discharges into the Ohio River Drainage Basin. Perched groundwater has been identified within the 6 to 12 ft bgs interval within the surficial gravel and sand deposits, underlain by a competent clay confining layer.

Two water-bearing units are located in the East Palestine region, consisting of buried glacial valleys and bedrock sandstones, shales, and clays that characterize regional geology. These aquifers are comprised of the Little Beaver Creek Outwash/Kame glacial aquifer system and a bedrock aquifer comprised of sandstone and shale. Recharge in the glacial aquifer system is reportedly high (7-10 inches per year [in/yr]) due to the permeable soils in the vadose zone (Angle, 1994).

Glacial aquifers in this region are highly variable, particularly within the buried valleys. The aquifers range from thin, isolated, discontinuous lenses of sand and gravel interbedded in thick sequences of glacial till or lacustrine deposits to relatively thick, extensive outwash deposits. The Little Beaver Creek Outwash/Kame glacial aquifer system includes a buried valley deposit that is approximately 36 feet thick, underlying the East Palestine valley from the late Wisconsin glacial episode. This valley deposit consists of permeable sand and gravel deposits interbedded with lenses that tend to be finer, thinner, and less well sorted; this aquifer system can have varying sustained yields up to 500 gallons per minute (gpm). At the edge of the valley base of the village of East Palestine are kame and kame terrace deposits that average sustained yields of 25 gallons per minute (gpm) (Crowell, 1993). The Little Beaver Creek Outwash/Kame aquifer system has reported 20% porosity with a hydraulic conductivity of 93.59 ft/day (OEPA, 2002). Water levels within the glacial aquifer system range from 45 to 65 ft bgs.

The bedrock aquifer underlying the Little Beaver Creek Outwash/Kame glacial aquifer system consist of shales and sandstones of the Pottsville and Allegheny groups. Yields obtained from the bedrock (consolidated) aquifers range from moderate to poor (10 to 25 gpm) and are primarily from the upper Pottsville and lower Allegheny Groups (Angle, 1994). The bedrock aquifer system has reported a hydraulic conductivity of 13.37 ft/day (OEPA, 2002).

The lateral flow direction for the perched groundwater system is still being determined. Initial investigation has observed the groundwater flow direction in the glacial aquifer is controlled by topography and drainage features. The general site-wide groundwater flow direction is from the east to west.

2 Purpose and Scope

The purpose of this Plan is to guide characterization activities involving the installation of a network of groundwater wells and implementation of groundwater and soil sampling efforts within and near the NSRC right-of-way in the vicinity of the derailment.

The scope of the groundwater characterization includes:

- An assessment of the nature and extent of groundwater and shallow soil impacts in the vicinity of the derailment area;
- The creation of a monitoring well network for longer term assessment of groundwater quality; and
- Provide the project team with shallow groundwater and soil quality data that will be used for assessing potential vapor intrusion (VI) pathways to nearby building occupants, and
- Hydrogeological evaluations for determining the current and future fate and transport of contamination away from the derailment area, if any.

Following the installation of the initial groundwater monitoring well network, soil sampling and associated data collection (Section 1.1), additional sampling locations will be proposed as necessary for both horizontal and vertical delineation of observed groundwater and soil impacts.

Because the nature of groundwater impacts associated with the derailment is not currently understood, groundwater or soil remediation activities are not included in this Plan. Groundwater or soil remediation methodologies will be developed as necessary after considering the characterization and delineation information generated from implementation of the activities proposed in this Plan.

Characterization of groundwater and soil, as discussed in this Plan, refers to groundwater and soil in the vicinity of the derailment that may have been impacted by constituents of concern (COCs) related to the derailment. Concurrent plans prepared under the UAO address monitoring and protection of potable water supplies, including installation and sampling of sentinel wells to monitor groundwater quality near potable water supply wells. Those activities are not part of the scope of this Plan but are included as supporting work plans to the Removal Work Plan.

Included in this Plan are references to relevant and applicable guidance instructions and documents from the following regulatory agencies (found in **Appendix A and B**):

- Ohio Environmental Protection Division (OEPA) Division of Environmental Response and Revitalization (DERR) Field Standard Operations Procedures (FSOPs)
- OEPA DERR Technical Guidance Manual (TGM) for Hydrogeologic Investigations and Groundwater Monitoring
- OEPA Division of Drinking and Ground Water (DDAGW) SOP for Per and Perfluorinated Alkyl Substances (PFAS)

Attorney-Client Privilege
Attorney Work Product/Prepared at the Direction of Counsel
Groundwater Characterization Work Plan

Table 2.1 Guidance Documents – FSOPs, Technical Guidance Instructions (TGIs), and TGMs

SOP # or Reference ¹	Title and Revision Date	Originating Organization	SOP option or Equipment Type (if SOP provides different options)
OEPA TGM	TGM for Hydrogeologic Investigations and Groundwater Monitoring, Rev. Date: 2009	OEPA DERR	See TGM
OEPA TGM: Chapter 4	Pumping and Slug Tests, Rev. Date February 2018	OEPA DERR	See TGM
OEPA TGM: Chapter 7	Monitoring Well Design and Installation, Rev. Date: February 2008	OEPA DERR	See TGM
OEPA TGM: Chapter 8	Monitoring Well Development, Maintenance, and Redevelopment, Rev. Date: February 2009	OEPA DERR	See TGM
OEPA TGM: Chapter 9	Sealing Abandoned Monitoring Wells and Boreholes, Rev. Date October 2020	OEPA DERR	See TGM
OEPA TGM: Chapter 10	Groundwater Sampling Rev. Date: October 2020	OEPA DERR	See TGM
OEPA	Field Standard Operating Procedures, Rev. Date: March 2021	OEPA DERR	See SOP
FSOP 1.2	Utility Clearance, Rev. Date: April 29, 2020	OEPA DERR	See SOP
FSOP 1.3	Field Documentation Rev. Date: April 29, 2020	OEPA DERR	See SOP

Attorney-Client Privilege

Attorney Work Product/Prepared at the Direction of Counsel

Groundwater Characterization Work Plan

SOP # or Reference ¹	Title and Revision Date	Originating Organization	SOP option or Equipment Type (if SOP provides different options)
FSOP 1.4	Sample Identification Nomenclature	OEPA DERR	See SOP
FSOP 1.5	Sample Custody and Handling, Rev. Date: May 6, 2020	OEPA DERR	See SOP
FSOP 1.6	Sampling Equipment Decontamination, Rev. Date: May 12, 2020)	OEPA DERR	See SOP
FSOP 1.7	Investigation Derived Waste, Rev. Date: May 21, 2020	OEPA DERR	See SOP
FSOP 1.9	Boring and Monitoring Well Decommissioning, Rev. Date: May 20, 2020	OEPA DERR	See SOP
FSOP 2.1.1	Discrete Soil Sampling, Rev. Date: May 26, 2020	OEPA DERR	See SOP
FSOP 2.1.5	Soil Description, Classification, and Logging, Rev. Date: June 30, 2020	OEPA DERR	See SOP
FSOP 2.2.1	Well Development, Rev. Date: July 14, 2020	OEPA DERR	See SOP
FSOP 2.2.2	Groundwater Level Measurement, Rev. Date: July 20, 2020	OEPA DERR	See SOP
FSOP 2.2.4	Groundwater Sampling (General Practices), Rev. Date: August 4, 2020	OEPA DERR	See SOP

Attorney-Client Privilege

Attorney Work Product/Prepared at the Direction of Counsel

Groundwater Characterization Work Plan

SOP # or Reference ¹	Title and Revision Date	Originating Organization	SOP option or Equipment Type (if SOP provides different options)
FSOP 2.2.6	Low-Flow (Low-Stress) Groundwater Sampling, Rev. Date: August 19, 2020	OEPA DERR	See SOP
FSOP 2.2.8	Groundwater Sampling Using a Bladder Pump, Rev. Date: December 3, 2020	OEPA DERR	See SOP
FSOP 2.2.9	Groundwater Sampling Using a Peristaltic Pump, Rev. Date: December 10, 2020	OEPA DERR	See SOP
FSOP 3.1.1	Photoionization Detector, Rev. Date: January 27, 2021	OEPA DERR	See SOP
PFAS SOP	SOP for Per- and Polyfluorinated Alkyl Substances Sampling at Public Water Systems, Rev. Date: March 3, 2020	OEPA DDAGW	See SOP
USEPA Groundwater Sampling SOP	Science and Ecosystem Support Division (SESD) Operating Procedure for Groundwater Sampling #SESDPROC-301-R3, Rev. date: March 6, 2013	USEPA	See SOP
PFAS TGI	TGI - Per- and Polyfluorinated Alkyl Substances Field Sampling Guide, Rev. Date: January 26, 2022	Arcadis	See TGI

Attorney-Client Privilege

Attorney Work Product/Prepared at the Direction of Counsel

Groundwater Characterization Work Plan

Notes:

All Field SOPs are located in **Appendix A and B.**

N/A – Not applicable

DERR - Division of Environmental Response and Revitalization

OEPA – Ohio Environmental Protection Agency

QP – Quality Procedure

Rev. - Revision

FSOP – Field Standard Operating Procedure

TGM – Technical Guidance Manual

3 Groundwater Characterization

The following sections are provided to cover the data quality and characterization objectives, along with details regarding the investigation methods and the rationale for the selection of the investigation points. As stated above, the characterization work is focused primarily on addressing the stated data gaps related to potential groundwater and soil impacts. Based on the field activities and data collected so far, Arcadis has identified the following data gaps that will be addressed in the proposed groundwater characterization work outlined in this Plan:

- Extent of impacts to groundwater in the perched groundwater system is unknown;
- Extent of impacts to soil at the site is unknown;
- Groundwater flow directions of perched groundwater system are not understood, along with the depth and dip to the competent clayey till layer, which is likely impacting the gradients and direction of groundwater flow; and
- Although recent groundwater quality data from the glacial aquifer indicates there are no measurable impacts to this groundwater system, the central portion of the derailment area (Area 1), nearest to the tracks, does not have monitoring wells present. Therefore, the groundwater quality in this area is unknown.

3.1 Data Quality Objectives

The Data Quality Objectives for this work are outlined in the Quality Assurance Project Plan (QAPP) that has been submitted for this program. In summary, the data quality for all data collection activities are expected to be definitive in nature, meaning that the data are of sufficient quality for making decisions about risk and/or compliance. In addition to this, the groundwater and soil data will be used to delineate the groundwater and soil impacts to the project's specified screening levels (SLs) which are provided in the QAPP and are discussed in more detail in Section 5 (Laboratory Method and QA/QC) below.

3.2 Objectives

The goals of the groundwater characterization work presented in this Plan are as follows:

- Provide a comprehensive investigation and dataset within the incident area to further develop understanding of soil types and the groundwater saturation profile.
- Assess the nature and extent related to groundwater and soil impacts by constituents released during the derailment.
- Identify hydrogeological parameters such as hydraulic gradients, direction of groundwater flow in water bearing zones, etc. for refinement of the CSM and fate and transport modeling.
- Assess the potential impacts of PFAS constituents in areas that underwent usage of aqueous filming foam (AFFF) as burn control in perched groundwater.
- Provide data for the project team to support evaluations as to whether a potential VI pathway is present.

The proposed sampling activities are described below and will be conducted in accordance with the *OEPA DERR FSOPs*, *OEPA TGM*, and the *OEPA DDAGW PFAS SOP* found in **Appendix A**. Analytical methods and associated

quality assurance/quality control (QA/QC) procedures to be used for sample analyses are described in the associated QAPP and in Section 5 of this Plan.

The results of the investigation described in this Plan will be used to evaluate potential risks to human health and ecological receptors at the site and to update/refine the CSM. A detailed summary of the media investigation results and revised CSM will be presented in subsequent reports.

3.3 Methods

3.3.1 Field Procedures

Field procedures listed in the subsections below for groundwater characterization work will be completed in accordance with applicable OEPA DERR FSOPs, found in **Appendix A**.

In select locations, groundwater samples will undergo PFAS analysis and will be collected in accordance with the *OEPA DDAGW PFAS SOP (Appendix A)* and the *PFAS Field Sampling Guide (Appendix B)*.

3.3.1.1 Field Documentation

Field documentation will be completed in accordance with *OEPA DERR FSOP 1.3*. Complete and accurate field documentation of field activities is crucial to ensure correct data collection and consistency. Field documentation for well installation, groundwater sampling, soil logging, and well development will be recorded in digital format. If digital field forms are not available, the data will be recorded on paper field forms.

General field notes will be recorded in a field notebook and will include any deviations that might occur from the approved plan. Field forms will be submitted in the subsequent report following the completion of the work in this Plan.

3.3.1.2 Sample Chain of Custody

Procedures concerning the handling and custody of samples prior to submittal to a laboratory will be in accordance with *OEPA DERR FSOP 1.5*. Field personnel will be responsible for maintaining proper custody while the samples are in their care. Sample custody forms will be filled out in indelible (blue or black) ink and completed in legible printed writing. All entry fields on chain of custody (COC) forms will be completed prior to submittal to the lab. Each COC form will have a signature and date prior to relinquishing to the lab. Sample IDs and sample location details will be uniquely identified and properly documented on field forms, logbooks, or other project record data sheets to permanently retain the information, as well as properly and completely marked on each sample bottle.

After collection, the samples will be sealed with custody labels to prevent tampering. Environmental samples will be preserved at 4 degrees Celsius °C (+/- 2°C) to prevent sample degradation. Samples will be inspected prior to packing and clear tap will be used to cover and protect the sample containers. Protective shipping materials, such as bubble wrap, will be used to help prevent container rupture during transport or shipment. Sample containers that are glass will be placed in plastic bags, sealed to prevent cross contamination, and placed upright in shipping coolers. The coolers will have the drainage holes sealed and will be lined with heavy-duty plastic garbage bags as liners. A field blank will be included in the cooler if samples are being submitted for volatile organic compound

Attorney-Client Privilege

Attorney Work Product/Prepared at the Direction of Counsel

Groundwater Characterization Work Plan

(VOC) analysis. Field blanks will be included with each sample shipment, regardless of sample media or analyte. The completed COC will be placed in a sealed plastic bag in the cooler with the samples for shipment and given to the commercial shipment carrier or handed to the laboratory courier for delivery directly to the lab.

3.3.1.3 Sample Nomenclature

Sample identification nomenclature will be conducted in accordance with *OEPA DERR FSOP 1.4*. The following guidelines will be implemented for varying media, listed below:

Sample identification based on media will use the following format:

- Location:
 - To distinguish the general area the samples were taken at the site, an abbreviated version of the site location will be added to the first part of the sample ID, this will vary depending on where the sample(s) were collected and will be notated in the field forms.
- Samples based on media:
 - Soil samples collected from excavations or manual labor e.g. hand auger = SO - boring number (no.) sequentially starting at 1 - (sample depth) e.g., SO-1-(1-2) – DATE e.g. (stated as year, month, day [yyyymmdd])
 - Soil sample collected with drilling equipment = SO - boring number sequentially starting at 1 – (sample depth) e.g., SB-1-(1-2) - DATE
 - Groundwater from open borehole = GW –boring number (depth) e.g., GW-1- (10-15 ft) - DATE
 - Groundwater from monitoring wells = MW-boring number (depth) e.g., MW-1 (10-15ft) - DATE
- Field Duplicates will use the following format:
 - FD: FD [Duplicate No.] - DATE
- Quality Control samples will use the following format:
 - Field Blank: FB [Field Blank No.] - DATE
 - Trip Blanks: TB [Trip Blank No.] - DATE
 - Equipment Blanks: EB [Equipment Blank No.] - DATE

3.3.1.4 Equipment Decontamination

Equipment decontamination will be conducted in accordance with the *OEPA DERR FSOP 1.6*. A designated area will be established to clean sampling equipment in the field prior to and following sample collection. Equipment cleaning areas will be set up within or adjacent to the specific work area, but not at a location that expose equipment to contamination (i.e., exposed to combustion engine exhaust). Detergent solutions will be prepared in clean containers for use in equipment decontamination. Decontaminated equipment will be handled with clean gloves, properly changed to prevent cross-contamination. Procedures that will be utilized in the field are detailed below:

- Wash the equipment/pump with potable water.
- Wash with detergent solution (Alconox®, Liquinox® or equivalent) to remove all visible particulate matter and any residual oils or grease.

Attorney-Client Privilege

Attorney Work Product/Prepared at the Direction of Counsel

Groundwater Characterization Work Plan

- If equipment is very dirty, precleaning gross debris with a brush and tap water may be necessary.
- If non-aqueous phase liquids are present, the use of isopropyl alcohol (free of ketones) or methanol is recommended. Cloth wipes or diluted solution can be used to remove the non-aqueous phase liquids that are hard to remove with detergent solution in step 2. Consult with project manager if non-aqueous phase liquids are present onsite and design an appropriate decontamination procedure that includes step 4.
- Rinse with deionized water.

All decontamination fluids will be containerized and disposed of in accordance with Section 4.3.9.

3.3.2 Soil Coring and Logging

The objective of the continuous soil coring and logging work is to determine the geologic setting and the presence or absence of perched groundwater in the shallow overburden. Additionally, chemical and physical characteristics of this region of soil (0-20 ft bgs) are also targeted as data needs for the fate and transport aspects of the CSM. These data include Total Organic Carbon (TOC) of the fill and till units and % moisture of the clayey till unit.

The locations for the soil coring and logging work are presented on Figure 4-1. All locations will be continuously cored and logged using Direct Push Technology (DPT) techniques. The logging procedures will follow *OEPA DERR FSOP 2.1.5*. All soils will be field screened using a Photo Ionization Detector (PID) as per *OEPA DERR FSOP 3.1.1*. All logging of lithology and PID screening data will be entered into a Fulcrum digital data collection platform.

The target depth of these explorations is expected to extend at least 10 ft into the clayey till unit. If wet soils are encountered in the upper 10-feet of the till, the coring should continue until the next dry unit is encountered. The project team should be notified if this scenario is encountered to determine if the exploration should fully transit the till unit. If NAPL is encountered during the exploration, the exploration should be terminated immediately and the field team should notify the project team.

Samples for TOC and %moisture will be collected according to the following plan:

- TOC samples will be collected for each geologic unit encountered during the program. A maximum of three TOC samples will be collected per location and a maximum of 20 TOC samples will be collected over the course of the soil coring program. These samples should not be collected in areas of suspected elevated impacts, as deemed by either visual observations or PID screenings.
- % moisture samples will be collected for soils collected within the upper 10 feet of the competent clay till layer. A maximum of two % moisture samples will be collected per location and a maximum of 20 % moisture samples will be collected over the course of the soil coring program.

Upon completing each of the soil coring and logging locations, and depending on what is observed at that location, the field team will install a shallow monitoring well using the techniques described in the section below.

3.3.3 Soil Sampling

Prescriptive source subsurface soil characterization will be completed using DPT methods in the unsaturated soil profile at each soil boring location. At approximately 1-ft intervals, a small hole will be punched into the butyrate plastic liner of each respective soil boring and screened using a PID equipped with a 11.7 electron volt (eV) lamp.

The PID readings will be recorded, and subsurface soil samples will be collected at locations with soil PID readings exceeding 10 times background levels. If the PID readings of a soil boring do not exceed 10 times the background levels; a soil sample will be collected from above the saturated interval in the perched zone once it is encountered. The quantity and depths of subsurface soil characterization samples will be dependent of PID observations in the field, a minimum of one subsurface soil sample will be collected per boring.

All subsurface soil characterization samples will be collected in accordance with *OEPA DERR FSOP 2.1.1* and PID screening will be conducted in accordance with *OEPA DERR FSOP 3.1.1*.

3.3.4 Shallow Monitoring Well Installation

Shallow wells will be installed at locations where perched water is encountered during the soil coring and logging work. All wells will be installed via HSA methods to determine potential groundwater impacts within the perched groundwater system. Prior to drill rig mobilization, Site utilities will be identified and located in accordance with *OEPA DERR FSOP 1.2 (Appendix A)*. If necessary, the locations of the shallow monitoring wells may be shifted to avoid local utilities or access constraints. The shallow monitoring wells will be installed in accordance with the *OEPA TGM: Chapter 7 (Appendix A)*. Actual depths will depend on when the competent clay layer is encountered during drilling. The well screen will be set approximately 2 to 5 ft above the encountered perched groundwater zone (documented at approximately 6 to 12 ft bgs) and will extend into the top of the underlying till layer. Approximate shallow monitoring well depths are from 10 and 18 ft bgs. The wells will be drilled to provide sufficient distance to the top of the well screen while also collecting the upper groundwater. Shallow monitoring wells will be constructed of 2-inch diameter, 5 or 10-ft-long polyvinyl chloride (PVC) pre-pack slotted well screens and associated PVC riser.

At least one groundwater water sample will be collected from the shallowest groundwater encountered at each shallow monitoring well location. It is possible that more than one saturated interval is encountered during the soil coring work. If this occurs, additional shallow monitoring wells will be installed at these intervals. After data analysis at the shallow monitoring wells, select wells will either be abandoned in place according to *FSOP OEPA FSOP 1.9* and *OEPA TGM: Chapter 9* or turned into permanent monitoring wells. Sampling frequencies for wells that are converted to permanent monitoring wells will follow the same protocol as listed below in 4.3.5.

Proposed shallow monitoring wells at 29 locations are included on **Figure 4-1**. The logic for proposed locations is discussed in Section 4.4 below.

3.3.5 Permanent Well Installation and Surveying

Monitoring well installation activities will be completed in accordance with the methods described in *OEPA TGM: Chapter 7 (Appendix A)*. Site utilities will be identified and located in accordance with *OEPA DERR FSOP 1.2*. If necessary, the locations of the monitoring wells may be shifted to avoid local utilities or access constraints.

A total of four monitoring wells have been installed by Arcadis within the incident area of East Palestine (MW-03, MW-06, MW-08, and MW-10). These wells have been sampled weekly since their installation in March 2023.

Six additional permanent monitoring wells (MW-01 and MW-02, and four currently un-named wells) are proposed to be installed within the incident area of the derailment site. Monitoring wells will be installed utilizing the roto-sonic drilling method. To minimize potential “drag-down” of potentially impacted surface soils, initial drilling will consist of drilling an outer-casing into, but not through, the anticipated competent clay layer. An inner drill string

Attorney-Client Privilege
Attorney Work Product/Prepared at the Direction of Counsel
 Groundwater Characterization Work Plan

will then be advanced through the outer-casing to a target depth of 10 ft below the lower contact of the upper confining clay layer and the underlying sand and gravel aquifer. Actual depths will depend on the location of permeable zones but will target the first water-bearing unit encountered (anticipated at approximately ~50 ft bgs). A single monitoring well is proposed at each location; no paired or nested wells are planned as part of the initial network.

Typical well completion is anticipated to be a 2-inch diameter polyvinyl chloride (PVC) well casing and riser, 0.010-inch slotted well screen with sand pack, bentonite seal, and grout to land surface. Wells will be completed with flush mount or stick-up protective covers and locking caps. In cases where previous groundwater investigations indicate free product is present, 4-inch diameter wells will be considered for installation.

Monitoring wells will be developed no earlier than 24 hours following installation, and sampling will occur no earlier than 24 hours following development.

Newly installed monitoring wells will be surveyed by a licensed Ohio Professional Surveyor once well installation activities are complete. The top of well casing and ground surface elevation will be recorded. The well coordinates will be identified via handheld Global Positioning System (GPS). Vertical Positioning is based on the North American Vertical Datum of 1988 and the Horizontal Positioning is based on the Ohio State Plane Coordinate System, North Zone, North American Datum 1983.

All permanent monitoring wells (including former shallow monitoring wells) will be sampled weekly until site activities are completed and after this time period, this frequency will be modified depending on what the data are indicating. If groundwater analytical results are non-detect for all constituents after four consecutive groundwater sampling events in any Arcadis incident-area monitoring well, the sampling frequency will be reduced to quarterly. Discussion regarding further reduction in sampling frequency will be presented in subsequent reports submitted after this Plan. Groundwater sampling procedures are detailed in Section 4.3.8. Analytes included in the groundwater sampling plan are listed in Section 5 of this Plan. Existing and proposed monitoring well locations are shown on **Figure 4-1** and boring and construction logs for existing wells within the incident area are provided in **Appendix C**.

3.3.6 Well Development

Shallow and permanent monitoring wells will be developed in accordance with *OEPA DERR FSOP 2.2.1* and the *OEPA TGM: Chapter 8 (Appendix A)*. Wells will be developed no earlier than 24 hours following installation, and sampling will occur no earlier than 24 hours following development. Shallow monitoring wells and permanent monitoring wells will be developed with an electric submersible pump system. The static water level and total depths of each well will be measured and the well volume calculated. Drawdown and field stabilization parameters will be monitored during development. The selected pump intake will be lowered to the top of the well screen and surged to dislodge particles within the well. Well development will be considered completed when there is evidence of a minimum of three well volumes purged, and parameter stabilization has occurred within three consecutive readings within the following stabilization criteria:

Table 4-1 Well Development Stabilization Criteria

Purge Water Parameters	Stabilization Criteria
Temperature	+/- 0.5 °C

Purge Water Parameters	Stabilization Criteria
pH	+/- 0.2 Standard Units (S.U.)
Specific Conductance	+/- 3%
Oxidation-Reduction Potential (ORP)	+/- 20 millivolts (mV)
Turbidity	10 Nephelometric Turbidity Units (NTUs) or +/- 10% for turbidity > or = 10 NTUs
Dissolved Oxygen (DO)	+/- 10% or 0.2 milligrams per liter (mg/L), whichever is greater

Purge water obtained during development activities will be containerized and for characterization and disposal in accordance with Section 4.3.9.

3.3.7 Water Level Measurements

Water level measurements in existing incident area monitoring wells will be measured in accordance with *OEPA DERR FSOP 2.2.2 (Appendix A)*. The static water level and total depth will be collected with an electronic water level meter and measured to an accuracy of 0.01 ft. Water levels will be collected prior to groundwater sampling from each shallow well and permanent monitoring well after well development. Additionally, transducers will be installed in existing and newly installed incident area monitoring well locations after the initial groundwater sampling event to monitor consistent water level variability within the glacial aquifer.

3.3.8 Groundwater Sampling

Groundwater sampling procedures will be conducted in accordance with *OEPA DERR FSOPs 2.2.4, 2.2.6, 2.2.9, 2.2.10* and the *OEPA TGM: Chapter 10 (Appendix A)*. Perched zone groundwater samples collected in areas of prior AFFF use will undergo PFAS analysis (locations are on **Figure 4-1**) as described in Section 5 of this Plan, therefore, these groundwater samples will also be collected in accordance with the *OEPA DDAGW PFAS SOP (Appendix A)* and the *PFAS Field Sampling Guide (Appendix B)*. After water level measurements are collected, purging using low-flow groundwater sampling techniques will be implemented. Purging will be conducted using a peristaltic pump at shallow monitoring wells and bladder pump at permanent monitoring wells. The pumping rate will minimize drawdown and not exceed 500 milliliters per minute (mL/min). Water levels will be collected throughout pumping to ensure that less than 0.3 ft of drawdown occurs. If the water level was initially above the screened interval and drawdown into the screened interval cannot be avoided, volumetric sampling by purging at least three well volumes will be conducted prior to sample collection.

While monitoring drawdown, water quality stabilization parameters using a flow-through cell will be utilized to provide at least three stabilization parameters. Field parameters will be recorded every 3 to 5 minutes. Field parameters include pH, temperature, conductivity, ORP, DO, and turbidity. Stabilization will be achieved when the following consecutive measurements are reached:

Table 4-2 Groundwater Sampling Stabilization Criteria

Purge Water Parameters	Stabilization Criteria (for at least three consecutive measurements)
Temperature	+/- 0.5°C
pH	+/- 0.2 S.U.
Specific Conductance	+/- 3%
ORP	+/- 20 mV
Turbidity	+/- 10% of the average value of three readings if > 10 NTUs, or a final value of less than 10 NTU
DO	+/- 0.3 mg/L

Low-flow purging will be continued until the water level drawdown and associated parameters have been stabilized. If stabilization is not achieved through low-flow sampling, volumetric sampling by purging at least three well volumes will be implemented prior to collecting a sample. If parameter stabilization is not achieved after three well volumes have been purged and it has been two hours since the purging was implemented, sampling will proceed, and the decision will be noted. If recharge to the well is insufficient to conduct minimal drawdown protocol, the well will be pumped dry and allowed to sufficiently recharge prior to sampling. In the case of sampling after groundwater recharge, the sampling time will be recorded in the field documentation sheet and efforts to obtain stabilization criteria will not be implemented.

Groundwater sampling will occur following stabilization in accordance with applicable FSOPs. The flow through cell will be detached prior to obtaining groundwater samples. Samples will be collected in a way that will minimize agitation and aeration.

Samples collected for VOC analysis will be collected after all other analytical parameters and will undergo the “soda straw” method in accordance with the *USEPA Groundwater Sampling SOP (Appendix A)*. This method can be completed in two ways, as detailed below:

- The tubing will be filled by either lowering it into the water column (A) or by filling it via suction applied by the pump head (B).
- When option A is implemented, the captured sample will be allowed to drain into the sample bottles once the tubing is removed from the well. If option B is implemented, once the sample has filled the tubing, the pump speed will be reduced and the direction reversed to push the sample out of the tubing into the sample vials.
 - In cases where option B is used, field staff will avoid completely emptying the tubing when filling the sample bottles to prevent introducing water that was in contact with the flexible pump head tubing.
- Either method will be repeated until all samples are collected.

Attorney-Client Privilege

Attorney Work Product/Prepared at the Direction of Counsel

Groundwater Characterization Work Plan

It is possible the shallow wells in the perched zone will have slow recharge rates, in these instances, traditional low-flow sampling techniques as detailed in OEPA FSOP 2.2.6 will be implemented in the place of the soda straw method to allow for sample collection of the full analytical suite detailed in this Plan.

When sampling for VOCs, if bubbles are observed at greater than 0.25 inches in diameter within the vial, the sample will be discarded, and a new sample will be taken. If the sample cannot be taken without the presence of bubbles, the presence of bubbles will be noted. Sample containers will be properly labeled and transferred directly to a sample cooler with bagged ice to preserve prior to shipment. Equipment will be properly decontaminated after sampling.

Purge water obtained during groundwater sampling activities will be containerized and for characterization and disposal in accordance with Section 4.3.9.

3.3.9 Aquifer Testing via Slug Tests

Aquifer testing will be performed at select monitoring wells to evaluate the hydraulic conductivity of saturated material at the Site and support groundwater characterization. It is anticipated that up to six of the shallow monitoring wells and six of the deeper monitoring wells will undergo this aquifer testing. The selection process for these wells will target varying geologic units that are encountered during the explorations. Slug tests will be performed in accordance with *OEPA TGM: Chapter 4 (Appendix A)*.

In general, slug tests involve rapidly removing a slug of water from the well to create a nearly instantaneous change in the hydraulic head in the well, then recording the rate of water level recovery in the well. The slug of water may be removed by manual bailing, pumping the well at the maximum pumping rate, or removing a slug of known volume that was placed into the well prior to testing. Sufficient pre-test water level monitoring should be performed to establish the baseline water level. Water levels should be recorded with a downhole data-logging pressure transducer. Occasional measurements with a manual water level indicator should also be recorded. The general guidelines for performing slug tests are as follows:

- Review characteristics of the well to confirm it is suitable for slug testing, including well depth, dimensions of screened interval, and filter pack size and distribution.
- Measure static water level and total well depth.
- Install downhole data-logging pressure transducer one foot above the bottom of the well. Measure the length of time the transducer is deployed in the well. Connect the transducer to a laptop computer. Configure transducer connection to monitor water levels in real time.
- Set the pressure transducer to record water levels at a high frequency (for example, one measurement every second).
- Begin logging water level with pressure transducer.
- Quickly remove a slug of water from the well using the selected water withdrawal method, in accordance with the TGM. After the slug of water has been removed from the well, collect water level recovery data at as high a frequency as possible using the pressure transducer and periodic measurements with a manual water level indicator if possible (approximately every one to two minutes at start of recovery and then every five minutes). Check the water level data to see that a good, quality data set has been collected. The data should show an initial, nearly instantaneous decrease in water level immediately after the slug has been removed, and a smooth water-level recovery curve. Ideal water level movement should be 10 to 50 cm.

Attorney-Client Privilege

Attorney Work Product/Prepared at the Direction of Counsel

Groundwater Characterization Work Plan

- If removing the slug of water with a pump for a step drawdown test, pump water for a minimum of three steps of 60 minutes or greater and gradually increase pump rate as necessary to maintain consistent drawdown. In this case it is likely the well will be pumped to dry or nearly dry conditions in the shortest amount of time possible with a high flow downhole pump. It is critical to calculate the total volume of water removed as accurately as possible to manage the purged water appropriately. For a well at a diameter of two inches, there is approximately 0.163 gallon of water per foot of water column. For a well at a diameter of four inches, there is approximately 0.65 gallon of water per foot of water column. Collect the discharge water into buckets or other type of container that will allow accurate measurement of water volume. Use a similar strategy if manually bailing the slug of water out of the well; collect the bailed water into a five-gallon bucket.
- Allow the water levels to return to within 90 % or greater of the static water level. If the well is recharging slowly, after 30 minutes, continue monitoring with a water level meter approximately every hour. Leave the transducer and pump in the well and use the backup transducer and pump. If the well is still recovering overnight, remove pump and transducer and make note of the time equipment was removed. The maximum length of time for collection of recovering water level measurements will be two weeks.
- The test may be terminated if a good, quality data set has been collected and the water levels have returned to within 90 % or greater of the static water level.

Some geologic formations of very low permeability such as tight clays will not recharge the well rapidly and it may take days, weeks, or possibly even months for water levels to return to within 90 % or greater of the static water level. In the case of delayed water level recovery, perform the slug test in accordance with these guidelines and the FSOP, and collect as much water level recovery data as possible within the constraints of the project scope, budget, and schedule. If the field work extends over several days, it may be acceptable to return to a very slowly-recharging monitoring well once or twice a day to measure water levels until the field phase has ended.

Downhole and re-useable equipment will be decontaminated prior to use at each location. Disposal of purge and decontamination water will be contained on-site and removed according to Section 4.3.9.

3.3.10 Investigation Derived Waste

Investigation Derived Waste (IDW) generated during the proposed investigation activities is anticipated to consist of decontamination fluids, personal protective equipment (PPE), purged groundwater, soil boring cuttings, and disposable sampling materials/general refuse (e.g. nitrile gloves, paper, plastic, etc.). IDW will be handled in accordance with the specified waste management plan, as well as local, state, and federal regulations. General guidance from *OEPA DERR FSOP 1.7 (Appendix A)* will be adhered to during IDW handling operations.

Transport and disposal of IDW will be coordinated with Incident Command Center Personnel.

3.4 Proposed Locations

The recently installed monitoring wells (MW-03, MW-06, MW-8 and MW-10) and the proposed 29 locations for the soil coring and shallow monitoring well installations are illustrated on **Figure 4-1**. **Figure 4-1** also shows the location of the six new deep monitoring wells (two of which are labelled MW-01 and MW-02) that are proposed as part of this work. Due to the dynamic nature associated with this site, the proposed locations may be modified during the course of this work as more information is obtained by the project team.

Attorney-Client Privilege

Attorney Work Product/Prepared at the Direction of Counsel

Groundwater Characterization Work Plan

The arrangements of the 29 proposed soil coring and shallow monitoring well locations were chosen to best satisfy the following goals:

- Evaluate perched groundwater impacts, in an east-west fashion, along the full length of the derailment area;
- Delineate the extent of perched groundwater impacts, if any;
- Provide a network of hydraulic head data that will facilitate the understanding of the flow patterns of the perched groundwater system;
- Target areas where underground utilities exist and may be serving as preferential pathways for perched groundwater flow; and
- Target areas of suspected and/or observed groundwater impacts that may warrant further types of investigation (i.e., VI).

The six permanent monitoring wells proposed for this work are intended to provide groundwater quality data for the deeper water bearing unit in the central portion of the derailment area. Hydraulic head and conductivity data will also be generated at these locations to further support the fate and transport aspects of the CSM.

Once analytical results at the proposed locations are confirmed, additional shallow and/or deeper monitoring wells may be installed in addition to the network detailed in this Plan to further characterize and delineate impacts within the incident area.

Upon finalizing the monitoring network needed for longer term monitoring, a portion of the shallow monitoring wells will either be abandoned or finished off as permanent monitoring wells. Likewise for the deeper monitoring wells, if it is determined that these wells are not needed for longer term monitoring, a portion of these will also be abandoned.

Prior to decommissioning or finishing monitoring wells, the Ohio EPA and US EPA will be notified for concurrence on the long-term plans for these monitoring wells.

4 Laboratory Methods and QA/QC

Groundwater and soil samples will be couriered or shipped to the Eurofins Canton, OH laboratory under standard chain-of-custody procedures and analyzed under an expedited turnaround time for the analysis. The analyte list for the VOCs and SVOCs, along with the laboratory’s detection limits and the screening levels to be used for delineation are specified in Section 5.1 below. Provisions for analyzing groundwater samples for other constituents are not included in this plan. Other constituents may be added to the COC list depending on the results of other plans and once the groundwater monitoring network is established.

Soil samples will also be analyzed for TOC and % moisture via the following methods:

- TOC (Walkley Black)
- % moisture (ASTM D2216)

Equipment blanks (consisting of rinseate from sampling equipment), field duplicates, and matrix spike/matrix spike duplicates (MS/MSDs) will be collected and analyzed at a 5% frequency. Trip blanks will accompany all coolers containing VOCs.

Level IV deliverables will be requested from the laboratory for work conducted under this Plan. Data validation will be conducted consistent with USEPA guidelines and is outlined in the QAPP for this Plan.

4.1 Analytical Parameters and Screening Levels

Table 4-1 Constituents of Concern and Screening Levels

Analyte	CAS #	Screening Drinking Water Standard (µg/L)	Groundwater ¹ VI Screening Level (µg/L)	Soil RSL for Protection of Groundwater (mg/kg)
Analytical Method – SW846 Method 8015: Aqueous and Soil Samples				
Propylene Glycol	57-55-6	400,000 ²	NA	421
Analytical Method – SW846 Method 8260D, Aqueous and Soil Samples				
1,2,4-Trimethylbenzene	95-63-6	56 ²	475	0.42
2-Ethylhexyl acrylate	103-11-7	500 ³	NA	2.8
Benzene	71-43-2	0.5 ²	2.46	0.0131
Cyclohexane	110-82-7	13,000 ²	1,570	55.2
2-Butanone	109-86-4	5,600 ²	3,540,000	6.1
Ethylbenzene	100-41-4	1.5 ²	6.09	4
Isopropylbenzene (Cumene)	98-82-8	450 ²	1,790	3.8

Attorney-Client Privilege

Attorney Work Product/Prepared at the Direction of Counsel

Groundwater Characterization Work Plan

Analyte	CAS #	Screening Drinking Water Standard (µg/L)	Groundwater ¹ VI Screening Level (µg/L)	Soil RSL for Protection of Groundwater (mg/kg)
Methyl acrylate	96-33-3	42 ²	4,170	0.046
m-Xylene & p-Xylene	179601-23-1	190 ²	624 ⁴	NA
n-Butyl acrylate	141-32-2	560 ³	NA	0.9
o-Xylene	95-47-6	190 ²	873	NA
Xylenes, Total	1330-20-7	190 ²	674	51
Toluene	108-88-3	1,100 ²	31,600	3.6
Vinyl chloride	75-01-4	0.019 ²	0.187	0.0034
Analytical Method – SW846 Method 8270D: Aqueous and Soil Samples				
1,1-Biphenyl	92-52-4	0.8 ²	73.8	0.045
1-Methylnaphthalene	90-12-0	1.1 ²	NA	0.031
2-Methylnaphthalene	91-57-6	36 ²	NA	0.96
Acenaphthene	83-32-9	530 ²	NA	28.5
Acenaphthylene	208-96-8	12 ³	NA	28.5
Anthracene	120-12-7	1,800 ²	NA	302
Benzaldehyde	100-52-7	19 ²	NA	0.022
Benzo[a]anthracene	56-55-3	0.03 ²	133	0.055
Benzo[a]pyrene	50-32-8	0.03 ²	NA	0.115
Benzo[b]fluoranthene	205-99-2	0.25 ²	NA	1.15
Benzo[g,h,i]perylene	191-24-2	0.12 ³	NA	67.6
Benzo[k]fluoranthene	207-08-9	2.5 ²	NA	11.5
Chrysene	218-01-9	25 ²	NA	47
Dibenzofuran	132-64-9	7.9 ²	NA	0.76
Dibenz(a,h)anthracene	53-70-3	0.03 ²	NA	0.115
Fluoranthene	206-44-0	800 ²	NA	239
Fluorene	86-73-7	290 ²	NA	28
Indeno[1,2,3-cd]pyrene	193-39-5	0.25 ²	NA	1.15

Attorney-Client Privilege

Attorney Work Product/Prepared at the Direction of Counsel

Groundwater Characterization Work Plan

Analyte	CAS #	Screening Drinking Water Standard (µg/L)	Groundwater ¹ VI Screening Level (µg/L)	Soil RSL for Protection of Groundwater (mg/kg)
Naphthalene	91-20-3	0.12 ²	9.39	0.002
Phenanthrene	85-01-8	50 ³	NA	67.6
Pyrene	129-00-0	120	NA	67.6
Ethylene glycol monobutyl ether	111-76-2	2,000 ^{*2}	NA	2.12
Analytical Method – SW846 Method 537 Modified: Aqueous (Shallow Wells Only)				
PFOA (Perfluorooctanoic acid)	335-67-1	0.06 ²	NA	NA
PFOS (Perfluorooctanesulfonic acid)	1763-23-1	0.04 ²	NA	NA
HFPO-DA (Hexafluoropropylene oxide dimer acid)	13252-13-6	0.06 ²	NA	NA
PFBS (Perfluorobutanesulfonic acid)	375-73-5	6.0 ²	NA	NA
PFHxS (Perfluorohexanesulfonic acid)	355-46-4	0.39 ²	NA	NA
PFNA (Perfluorononanoic acid)	375-95-1	0.059 ²	NA	NA
PFBA (Perfluorobutanoic acid)	375-22-4	18 ²	NA	NA
PFHxA (Perfluorohexanoic acid)	307-24-4	9.9 ²	NA	NA

Notes:

CAS – Chemical abstract service

µg/L – Micrograms per liter

NA – Not applicable

1 VISLs presented are from the USEPA Residential Vapor Intrusion Screening Levels (VISLs) using a Target Cancer Risk (TCR) of 1E-06 and a Hazard Quotient (THQ) of 1.0 and a temperature of 15°C.

2 USEPA RSL Resident Tap Water (TR=1E-06/THQ=1.0) – <https://www.epa.gov/risk/regional-screening-levels-rsls-generic-tables>

3 ATSDR – Agency for Toxic Substances and Disease Registry Calculated Criteria

4 VISL for m-xylene presented as it is lower than that of p-xylene.

* Analyte is not included in approved EPA Method list. Analyzed by laboratory-modified method shown.

Attorney-Client Privilege
Attorney Work Product/Prepared at the Direction of Counsel
Groundwater Characterization Work Plan

5 Data Review and Decision Statements

Following receipt of validated data, the groundwater and soil results will be evaluated for each of the COCs against the screening levels identified in Section 5.1. Upon review, the following decisions statements, in the form of questions and applicable actions will be assessed.

Table 5-1 Decision Statements

Investigation Question	Action
<p>Is groundwater or soil impacted by chemicals released during the derailment?</p>	<p>-Groundwater and soil sampling and analyses will be conducted to determine the presence of derailment-related constituents at locations near the derailment location.</p> <p>-If groundwater or soil sample results show concentrations of VOCs and SVOCs below ¹screening levels, groundwater or soil will not be considered impacted at that location.</p> <p>-If groundwater or soil sample results show concentrations of VOCs and SVOCs above ¹screening levels, groundwater or soil will be considered impacted at that location. In these cases, additional work associated with VI investigation would also be initiated depending on the proximity (typically within 100 feet) of occupied building to a given impacted location.</p> <p>-²If deemed necessary, repeated sampling events may be used to assess variability and trends in groundwater results.</p>
<p>What is the extent of groundwater or soil impacts associated with chemicals released during the derailment?</p>	<p>-Groundwater and soil data will be collected to establish a perimeter of horizontal and vertical delineation around locations of observed ¹screening level exceedances (if any).</p> <p>-If groundwater or soil sample results show concentrations of VOCs and SVOCs below ¹screening levels at a perimeter location, groundwater or soil impacts will be considered delineated that location.</p> <p>-If groundwater or soil sample results show concentrations of VOCs and SVOCs above ¹screening levels at a perimeter location, groundwater or soil will be considered impacted at that location and additional delineation locations will be ²evaluated. In these cases, additional work associated with VI investigation would also be initiated depending on the proximity (typically within 100 feet) of occupied building to a given impacted location.</p> <p>-²If deemed necessary, repeated sampling events may be used to assess variability and trends in groundwater results.</p>
<p>What is the configuration for the permanent groundwater monitoring well network?</p>	<p>-Shallow monitoring wells will either be finished off as permanent wells or decommissioned depending on extent of observed groundwater</p>

Attorney-Client Privilege
Attorney Work Product/Prepared at the Direction of Counsel
 Groundwater Characterization Work Plan

Investigation Question	Action
	impacts from questions 1 and 2. The final configuration will be discussed with Ohio EPA and US EPA for approval.

1. Screening levels refer to both groundwater and soil screening and VI screening levels shown in Section 5.1.
2. Delineation work associated with questions 1 and 2 are expected to only require one sample event however, if site conditions (i.e. cleanup activities or other engineering activities) are changing in a manner that could impact the groundwater quality, repeated sampling events may take place at certain locations.
3. Information regarding groundwater flow directions and other hydrogeological parameters will be used in conjunction with the groundwater quality data to select additional investigation locations as needed.

6 Reporting and Schedule

The task schedule for the groundwater characterization work will proceed as follows:

- Groundwater Characterization Work Plan submittal;
- Field Implementation (after Incident Command Center approval of Work Plan);
 - Assuming access or other constraints do not cause significant delays, this work is expected to take place in a continuous manner within a single mobilization.
- Interim Groundwater Characterization Summary Report(s) will be submitted within four weeks of the end of the field work. The expected deliverables include:
 - Tabulated groundwater quality data;
 - PFAS analytical data may not be available with this deliverable due to limited lab turnaround times, if this data is not available in the above report, it will be available in the Final Groundwater Characterization Summary Report.
 - Plan view map showing extent of groundwater and soil impacts with step outs for additional sampling, as needed;
 - Cross sections and potentiometric surface maps with inferred groundwater flow directions;
 - Recommendations for potential further data collection needs; and
 - A preliminary risk evaluation focused on VI and other possible receptors.
- Final Groundwater Characterization Summary Report will be submitted within eight weeks of the end of the field work and will include:
 - Updated CSM that considers the components listed in EPA's guidance document on CSMs (EPA-542-F-11-011 and EPA-542-G-18-004) and is supported by updated tables and figures that are listed in the interim report; and
 - Recommendations for long-term groundwater monitoring and/or corrective actions.











7 References

- Angle, Mike. 1994. Groundwater Pollution Potential of Columbiana County, Ohio. Groundwater Pollution Potential Report No.35. September.
- Brockman, C. 1998. Physiographic Regions of Ohio. State of Ohio Department of Natural Resources, Division of Geological Survey. Map with text.
- Crowell, K. 1978. Groundwater Resources of Columbiana County. State of Ohio Department of Natural Resources, Division of Water. Map with text.
- EnviroScience. 2023. East Palestine, Ohio, Surface Water Natural Resources - Little Beaver Creek Watershed. March 19.
- National Oceanic and Atmospheric Administration (n.d.). *Climate at a Glance Statewide Time Series*. Noaa.com. Retrieved May 4, 2023, from <https://www.ncei.noaa.gov/access/monitoring/climate-at-a-glance/statewide/time-series>
- Ohio Department of Natural Resources. 2019. Groundwater Pollution Potential of Columbiana County, Ohio. No. 35. December.
- OEPA. 2002. Drinking Water Source Assessment for the Village of East Palestine PWS ID# OH1500912. July.
- Stantec. 2023 [in review]. Sentinel Monitoring Well Installation and Groundwater Sampling Work Plan. March.
- US EPA. 2011. Environmental Cleanup Best Management Practices: Effective Use of Project Life Cycle Conceptual Site Model. EPA 542-F-11-011.
- US EPA. 2018. Technical Guidance to Streamline Site Cleanup: Smart Scoping, Strategic Sampling and Data Management Best Practices. EPA 542-G-18-004.
- White G. 1961. Illonian and Wisconsin Drift of the Southern Part of the Grand River Lobe in Eastern Ohio. Bulletin of the Geological Survey of America. Report of Investigations No. 12. September.
- White, George and Totten, S. 1985. Glacial Geology of Columbiana County, Ohio. Ohio Department of Natural Resources, Division of Geological Survey. Report of Investigations No. RI 129, 25 pp.

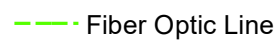
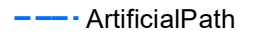
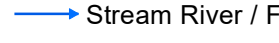
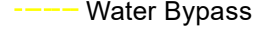
Figures

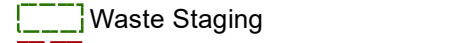

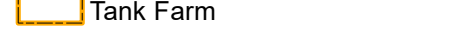
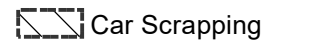
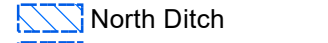
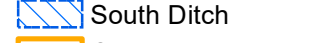
Legend

-  Completed Monitoring Well
-  Proposed Monitoring Well
-  Stantec Sentinel Well
-  Proposed Shallow Monitoring Well Locations
-  Shallow Monitoring Wells Selected for PFAS Analysis
-  Fiber Optic Line
-  Artificial Path
-  Stream River / Flow Direction
-  Water Bypass
-  Expanded Waste Staging Areas
-  Waste Staging
-  Burn Pit
-  Tank Farm
-  Car Scrapping
-  North Ditch
-  South Ditch
-  County Boundaries

Map Date: 6/20/2023
 Drone image dated: 06/19/2023
 0 200 400
 Feet

NORFOLK SOUTHERN
 EAST PALESTINE, OHIO
GROUNDWATER CHARACTERIZATION WORK PLAN

PROPOSED SAMPLING LOCATIONS

 **ARCADIS**

FIGURE
4-1

Attorney-Client Privilege
Attorney Work Product/Prepared at the Direction of Counsel

Appendix A

Technical Guidance Instructions and Field Standard Operating Procedures

Utility Clearance

FSOP 1.2 (April 29, 2020)

Ohio EPA Division of Environmental Response and Revitalization

1.0 Scope and Applicability

- 1.1 Underground utility clearance must be requested prior to conducting hand or mechanical excavation of soil or sediment per Ohio Revised Code (ORC) 3781.25(I).
- 1.2 The entity conducting the excavation/drilling work (e.g., the excavator) must coordinate underground utility clearance. Utility clearance for work performed by Division of Environmental Response and Revitalization (DERR) staff may be coordinated by the DERR Site Investigation Field Unit (SIFU) staff or a DERR district office site coordinator or inspector. (See Section 4.1 regarding notification requirements for the Ohio Utilities Protection Service (OUPS) if a contractor is performing the work.)
- 1.3 SIFU or the DERR district office staff responsible for submitting the utility clearance request will be responsible for retaining documentation of the requests, in electronic format, per Ohio EPA record retention schedules.

2.0 Definitions

Not applicable

3.0 Health and Safety Considerations

- 3.1 Contact with underground or overhead utilities may result in injury or death to personnel or the public, damage to or destruction of equipment or facilities, and/or damage to the environment.
- 3.2 If the site does not appear to have been cleared (e.g., no evidence of flags or paint markings or notification of clearance), contact the appropriate underground protection service, utility and/or facility as applicable before proceeding with work.
- 3.3 If a utility line is hit or damaged, walk away immediately and clear the area of personnel and the public. Contact OUPS and the appropriate local utility companies (see Section 4.1). As appropriate and safe, expeditiously notify the property owner and the local government of the situation. Call 9-1-1 if there is any injury or potential threat for injury or if a substance is being released to air, such as natural gas, or if there is a fire, explosion, or a threat of fire or explosion.

4.0 Procedure Cautions

- 4.1 Ohio currently requires that the excavator notify the OUPS prior to excavation, drilling or other underground activities (See Section 7.1.1). Note that if an LOE or other contractor is performing the work, then that contractor must notify OUPS.
- 4.2 Many manufacturing plants and other facilities have their own internal underground utilities and infrastructure that are not covered by OUPS (see Section 7.3). Knowledgeable facility staff, such as a plant engineer, maintenance supervisor, or health and safety personnel, should be contacted if possible, to locate and clear any facility-owned underground utilities or infrastructure.
- 4.3 OUPS member utilities may not mark lateral or service connections from main utility lines to residences and commercial or industrial buildings (see Section 7).
- 4.4 Do not excavate within the tolerance zone, or “approximate location” of the underground utility without the supervision of the owning utility. The “approximate location” as defined in ORC 3781.25(D), is *“the site of the underground utility facility including the width of the underground utility facility plus eighteen inches on each side of the facility.”* Any excavation within the tolerance zone should be performed with hand tools in a careful and prudent manner until the marked utility is exposed.
- 4.5 Additional utility investigation procedures, such as those described in Section 7.2, may be appropriate as supplemental procedures but may never be used in place of contacting OUPS. In case of a dispute in utility locations between a supplemental procedure and OUPS, or member utilities, contact OUPS or appropriate member utility for verification of utility locations.
- 4.6 DERR staff members are not authorized to perform underground utility clearance. Do not attempt to use SIFU’s geophysical equipment or other DERR equipment to locate underground utilities (or to provide “supplemental” information) for utility clearance.

5.0 Personnel Qualifications

- 5.1 Ohio EPA personnel working at sites that fall under the scope of OSHA’s hazardous waste operations and emergency response standard (29 CFR 1910.120) must meet the training requirements described in that standard.
- 5.2 It is strongly recommended that Ohio EPA personnel who request utility clearance for investigations attend safety training provided by OUPS so they have a solid understanding of utility clearance procedures.

6.0 Equipment and Supplies

Not applicable

7.0 Procedures

7.1 Contact the following underground protection services to clear utilities prior to excavation:

7.1.1 Contact OUPS at **8-1-1** or **(800) 362-2764** at least 48 hours [two (2) working days] but no more than 10 working days prior to digging. Working days do not include weekends or legal holidays. (As an alternative, OUPS may be contacted online using i-dig Newtin RTE. For more information on i-dig, see www.oups.org.)

7.1.1.1 Provide the necessary information as detailed on the attached OUPS Locate Work Order Form to OUPS to accurately locate site and/or work area. Let OUPS know if the sampling locations have been pre-marked (locations should be pre-marked with white paint and/or white flags). Also, let utility locator know if there is a distance around the marked location that should also be cleared (e.g., 20 feet radius around marked location).

7.1.1.2 OUPS will provide notification to full membership utilities to mark or clear utilities.

7.1.1.3 OUPS will provide a ticket number for the location request. Make sure to record the ticket number in the site-specific work plan or other appropriate document accessible to personnel in the field. The entity that will be conducting the excavating/drilling activities may use OUPS Positive Response to check on the status of clearing or marking

7.1.1.4 If work does not begin within 10 working days of the request, another OUPS utility location request must be made.

7.1.1.5 Underground utility lines may be marked by utility companies or their locating services with flags or paint or both. Color codes for marking utilities are shown on the attached OUPS Utility Color Code Guide.

7.1.1.6 Work may continue until markings are no longer visible. If markings are no longer visible, OUPS must be contacted to remark utilities.

7.1.1.7 If the site is vacant, a sign with the street address may need to be posted so that OUPS can locate the site.

7.2 In addition to contacting OUPS, the use of a private utility locator service should be considered. This is especially applicable for large sites where OUPS does not locate facility-owned underground utilities, where site areas are located away from utility main lines, or at sites where the past land uses and industrial or commercial activities are not well known. This may also be applicable for sites involving residential properties.

7.3 If at a manufacturing plant or other facility, contact knowledgeable facility staff such as a plant engineer, maintenance supervisor, or health and safety personnel to locate any facility-owned underground utilities or infrastructure for utility clearance (please refer to paragraph 4.2).

8.0 Data and Records Management

Not applicable

9.0 Quality Assurance and Quality Control

Not applicable

10.0 Attachments

Ohio Utility Protection Service Locate Work Order Form

Ohio Utility Protection Service Utility Color Code Guide

American Electric Power Ohio Public Safety Fact Sheet

11.0 References

Ohio Revised Code 3781.25(D) and 3781.25(I)

O.U.P.S. LOCATE WORK ORDER

CALL 48 HOURS BEFORE YOU DIG -- 800-362-2764

COLOR CODES: Red = Electric Orange = Phone/Cable TV Yellow = Gas Blue = Water Green = sewer
White = Proposed Excavation

COMPLETING ENTIRE FORM HELPS TO ENSURE A MORE ACCURATE AND TIMELY LOCATE

Contact Phone # _____ Caller Name _____

Company Name _____

Fax _____ Email _____

County _____ City/Township _____

Address/Location of Work _____

Extent of Work: Front/Sides/Rear _____ Farthest Distance/Direction back off Road _____

Lot # _____ Subdivision _____ Builder Name _____

Cross / Between Streets _____

Distance & Direction from Cross Street _____

Date of Excavation _____ Start Time of Excavation _____

Type of Work _____

Working for Company _____ Work Done By Company _____

_____ Means of Excavation _____ Blasting _____ Pre Markings _____ Meet

_____ RR Right of Way _____ Highway Mile Marker At/From _____

Comments _____

OUPS TICKET NUMBER _____

Dig Safely.

COLOR CODES FOR LOCATING UTILITY LINES

RED	Electric Power Lines, Cables, Conduit and Lighting Cables
YELLOW	Gas, Oil, Steam, Petroleum, or Gaseous Materials
ORANGE	Communication, Alarm or Signal Lines, Cables or Conduit
BLUE	Potable Water
PURPLE	Reclaimed Water, Irrigation and Slurry Lines
GREEN	Sewers and Drain Lines
PINK	Temporary Survey Markings
WHITE	Proposed Excavating

Tolerance Zone: Width of Underground Facility Plus 18" on Each Side.



OHIO
Utilities Protection
SERVICE
Call Before You Dig

1-800-362-2764
www.oups.org

Public Safety

Look Up for Lines

Keep a Safe Distance from All Overhead Power Lines

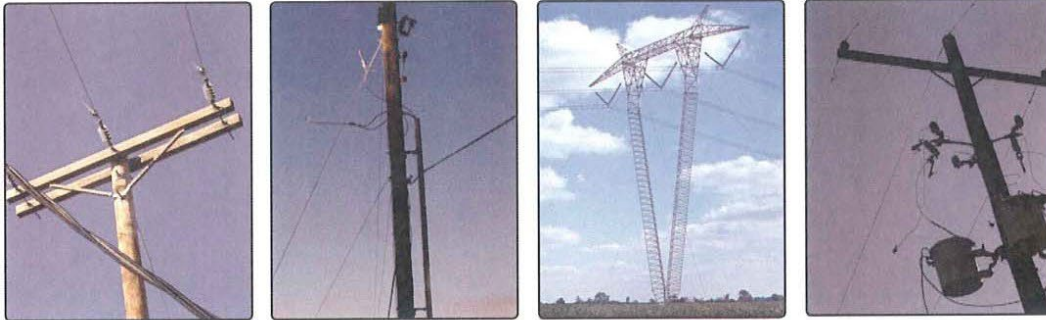

Most contact with overhead power lines is accidental, but can result in severe injuries and even death. Fortunately, most, if not all, electrical accidents can be prevented. Before you begin any job, whether it's installing a TV antenna on your roof or constructing a new building, it's important to be aware of power line locations and the necessary safety precautions.

Working Around Electricity

Electricity always attempts to travel to the ground and will follow all paths to get there. If a conductor of electricity becomes available, the electricity will follow that path to ground. Tools and equipment you use, and even your own body, are excellent conductors.

What does this mean? Let's say you're using a ladder to do some work around your house. If that ladder accidentally touches an overhead power line, the ladder (and you) could become the path for the electricity, sending electricity through the ladder and your body, which can cause severe injuries or even death.

Minimum Clearances

Always look up first for overhead power lines. If you see some in the area, there is a MINIMUM clearance of 10 feet which should be maintained. The minimum clearance increases as the voltage increases. Minimum clearances also can be affected by weather conditions, the type of work being performed, the equipment being used and other factors. Additional minimum clearances for various voltages are shown in this chart.

Line Voltage	Minimum Clearances
Up to 50,000 volts	10 feet
50,000 to 200,000 volts	15 feet
200,000 to 350,000 volts	20 feet
350,000 to 500,000 volts	25 feet
500,000 to 750,000 volts	35 feet
750,000 to 1,000,000 volts	45 feet

Equipment and Overhead Lines

- Use a clean, dry wood or fiberglass ladder if electric lines are anywhere in the area. They are less likely to conduct electricity than a metal ladder.
- When installing an antenna, position it at least 1.5 times its total length away from power lines. If it starts to fall, let it go and stay clear.
- Be certain to maintain a safe clearance when the bed of a dump truck is raised.
- Know the minimum distance a crane can operate safely near a power line. Keep all parts of the crane and its load outside this area. If your crane does come in contact with an overhead line, don't leave the cab, call 9-1-1 and the power company immediately.
- Designate a worker responsible for signaling the crane operator when any part of the crane or its load approaches the minimum clearance limit. The worker should never touch the crane.
- Some jobs may require the line be de-energized to complete the task safely. The power company will work with you to determine if this is needed.
- Do not rely on proximity warning devices such as hook insulators or boom guards, because each has its limitations.
- Take time to plan any job and contact your local power company if you have any questions.



For more public safety information, visit: <http://www.AEPOhio.com>

Field Documentation

FSOP 1.3 (April 29, 2020)

Ohio EPA Division of Environmental Response and Revitalization

1.0 Scope and Applicability

1.1 Accurate and complete field documentation of sampling and other field activities is critical for ensuring the technical integrity and legal defensibility of environmental site assessments, remedial investigations/feasibility studies, remedial activity implementations, facility investigations, program field audits, and other field activities.

1.2 Field documentation may include, but is not limited to the following:

- 1.2.1 Field logbooks or field log sheets (including any LOE field logs)
- 1.2.2 Activity-specific field forms
- 1.2.3 Chain-of-Custody (COC) forms
- 1.2.4 Photographs
- 1.2.5 Electronic data (e.g., Global Positioning System (GPS)) location coordinates, water level data

1.3 For Contract Laboratory Program (CLP) projects, additional field documentation requirements are applicable. Contact the DERR Site Investigation Field Unit (SIFU) for assistance with CLP project requirements before field activities are initiated.

2.0 Definitions

Not applicable

3.0 Health and Safety Considerations

Not applicable

4.0 Procedure Cautions

Not applicable

5.0 Personnel Qualifications

Ohio EPA personnel working at sites that fall under the scope of OSHA's hazardous waste operations and emergency response standard (29 CFR 1910.120) must meet the training requirements described in that standard.

6.0 Equipment and Supplies

- 6.1** Appropriate activity-specific field forms (as needed)
- 6.2** COC forms, sample labels, custody seals (as needed)

- 6.3 Clipboard
- 6.4 Digital camera
- 6.5 Field logbook or field log sheets (waterproof, when necessary)
- 6.6 Field scale or ruler (as needed)
- 6.7 GPS and data logging equipment (as needed)
- 6.8 Maps or site plans for reference and documentation
- 6.9 Pens and markers (waterproof, when necessary)
- 6.10 Small dry-erase board with dry-erase markers (for photograph identification)

7.0 Procedures

7.1 Field logbook/field log sheet documentation:

7.1.1 Document the following types of information for site assessment activities in the field logbook or on log sheets, as appropriate for site-specific work plan activities:

- 7.1.1.1 Site or project name
- 7.1.1.2 Site location/address
- 7.1.1.3 People and affiliation present
- 7.1.1.4 Date(s) and time(s) of field activities
- 7.1.1.5 Weather conditions
- 7.1.1.6 Ohio EPA personnel and other persons on-site
- 7.1.1.7 Health and safety field monitoring data (e.g., LEL/O₂ meter or PID readings)
- 7.1.1.8 General field observations
- 7.1.1.9 Photograph log
- 7.1.1.10 Interview notes
- 7.1.1.11 Problems or unexpected conditions encountered

7.1.2 If activity-specific field forms are not available, use a field logbook to document sampling and other field activities. Record all form-required information, which may include, but is not necessarily limited to the following types of information (generally in the following order):

- 7.1.2.1 Sampler's name(s)
- 7.1.2.2 Sample identification number (refer to FSOP 1.4, Sample Identification Nomenclature)
- 7.1.2.3 Sample collection date and approximate time
- 7.1.2.4 Sample location (narrative description as needed)
- 7.1.2.5 Sample matrix type (soil, sediment, groundwater, surface water, soil gas, etc.)
- 7.1.2.6 Depth intervals for soil samples
- 7.1.2.7 If required, the classification or description of soil samples
- 7.1.2.8 Sample type (grab, composite, duplicate, equipment blank, etc.)
- 7.1.2.9 Field screening data associated with the sample (e.g., PID readings)

- 7.1.2.10 Laboratory parameters to be performed (e.g., VOCs)
- 7.1.2.11 Sampling location photograph description/documentation
- 7.1.2.12 Any other relevant information needed to support the technical integrity or legal defensibility of the sampling process

7.2 The following activity-specific field forms should be used to document specific field activities:

- 7.2.1 Boring Log and Monitoring Well or Soil Gas Probe Construction Diagram
- 7.2.2 Ground Water Sampling
- 7.2.3 Monitoring Well Surveying
- 7.2.4 Monitoring Well Development
- 7.2.5 Vapor Intrusion Forms

7.3 Chain of Custody (COC) forms

- 7.3.1 Always complete a COC form when submitting samples to any laboratory for analyses.
- 7.3.2 If submitting samples to a DERR contract laboratory, contact the SIFU Laboratory Coordinator, a District Office Laboratory Coordinator, or the contract laboratory for specific instructions for completing COC forms.
- 7.3.3 If submitting samples to the Ohio EPA Division of Environmental Services (DES) laboratory, use DES COC forms. Contact DES for specific instructions on completing their COC forms.
- 7.3.4 For federal site assessment projects, use the required U.S. EPA Scribe sample management and reporting software program to create electronic COC forms for the U.S. EPA Contract Laboratory Program (CLP) sampling projects. DERR SIFU has access to the Scribe program.
- 7.3.5 For federal site assessment projects, vapor samples are to be sent to the U.S. EPA Analytical Services Branch (ASB) for analyses. ASB provides COC forms.

7.4 Photographic documentation

- 7.4.1 Take photographs to document site features and conditions that are relevant to the environmental site assessment process, including selected sampling locations and samples if necessary.
- 7.4.2 Log photographs as necessary for project documentation in the field logbook, log sheets, or on other suitable references (e.g., maps or site plans) with respect location/orientation and subject matter.

7.4.3 Use digital cameras capable of embedding the locational, date and time data within the photograph file. It is strongly recommended not to take photographs with personal cell phones.

7.4.4 Site photographs are to be uploaded to the Ohio EPA photograph management system (*i.e.*, LYNX).

7.5 GPS data and other data logging documentation (*e.g.*, water-level or water chemistry dataloggers that may be used for aquifer testing and water quality evaluation). Site-specific file names are to be used for data files.

7.5.1 Create sample location identifications in accordance with FSOP 1.4, Sample Identification Nomenclature.

7.6 Retention of field documentation

7.6.1 Ensure that field documentation is properly filed for future reference. Always provide copies to the appropriate district office personnel.

7.6.2 Scan original copies of written field documentation so that electronic copies are readily available for transmission, review, and reference. Retain all original written field documentation and electronic copies at the appropriate district office.

8.0 Data and Records Management

Ensure that all field documentation records are managed in accordance with the Agency records retention policy. Also ensure that all field documentation records are maintained in compliance with Agency and DERR personally identifiable information (PII) policies.

9.0 Quality Assurance and Quality Control

The Superfund QAPP is to be referenced, primarily for federal site assessment activities.

10.0 Attachments

None

11.0 References

FSOP 1.4, Sample Identification Nomenclature

Sample Identification Nomenclature

FSOP 1.4 (April 29, 2020)

Ohio EPA Division of Environmental Response and Revitalization

1.0 Scope and Applicability

- 1.1 This procedure provides a standard nomenclature convention for environmental sample identification. The use of a standard convention facilitates the progress of field sampling activities, reduces the potential for confusion regarding sample identification, and improves the ease of reviewing laboratory analytical results.
- 1.2 Alternative sample identification conventions may be used for the following circumstances:
 - 1.2.1 When the regulatory program under which the sampling work is being performed requires an alternative sample identification convention
 - 1.2.2 At sites where sampling already has been performed and where use of an existing sample identification convention would promote consistency and help avoid potential confusion
 - 1.2.3 When soil or sediment samples are collected using incremental or other composite sampling methodologies
 - 1.2.4 At sites where unique sampling situations are found to exist.
- 1.3 If collecting environmental samples from a site with multiple parcels or multiple areas of contamination (*e.g.*, a Voluntary Action Program (VAP) property with multiple identified areas), qualifiers that identify the sample location (*e.g.*, parcel or VAP identified area) may be added to the sample identification nomenclature. Due to the wide variety of sites and circumstances associated with environmental assessments, such nomenclature is best developed and applied on a site-specific basis.
- 1.4 Anticipated deviations from this procedure should be documented in the site-specific work plan with a brief explanation of the reason(s) for the deviation.
- 1.5 Ohio EPA's Quality Assurance Project Plan (QAPP) for Targeted Brownfield Assessments (TBAs) requires the use of this procedure.

2.0 Definitions

Not applicable

3.0 Health and Safety Considerations

Not applicable

4.0 Procedure Cautions

- 4.1 The geographic location (latitude and longitude) of each sampling location will be determined using Global Positioning System (GPS). Accordingly, sample identification does not typically need to incorporate information regarding geographic direction, e.g., adding “N” to the identification of a soil sample collected from the north side of an excavation.
- 4.2 Given concerns regarding personally identifiable information (PII), the use of property owner names and addresses in sample nomenclature should be carefully evaluated, particularly for federal site assessment sites.
- 4.3 Certain regulatory programs (e.g., the U.S. EPA Contract Laboratory Program or CLP) may require the use of sample identification conventions that differ from those prescribed by this procedure.

5.0 Personnel Qualifications

Ohio EPA personnel working at sites that fall under the scope of OSHA’s hazardous waste operations and emergency response standard (29 CFR 1910.120) must meet the training requirements described in that standard.

6.0 Equipment and Supplies

Not applicable

7.0 Procedures

- 7.1 The sample identification consists of an abbreviation for the sample matrix type and a consecutive sample number separated by a hyphen, e.g., **SO-1** (soil sample number one) unless otherwise indicated. Environmental sample matrices and association abbreviations (**bold**) include the following:

- 7.1.1 Soil samples:

- 7.1.1.1 **SO** for soil samples collected using manual labor (e.g., by scoop or hand auger) or from excavations; the **SO** abbreviation is followed by a consecutive sampling location number, a hyphen, and the approximate sample depth interval (expressed as tenths of feet) in parentheses, e.g., SO-1 (0.5-1.5ft)

- 7.1.1.2 **SB** for soil samples collected using drilling equipment; the **SB** abbreviation is followed by a consecutive boring location number, a hyphen, and the approximate sample depth interval (expressed as tenths of feet) in parentheses, e.g., SB-1 (0.5-1.5ft)
- 7.1.2 **SE** for sediment samples
- 7.1.3 **SW** for surface water samples
- 7.1.4 Ground water samples:
 - 7.1.4.1 **MW** for monitoring well ground watersamples
 - 7.1.4.2 **GW** for ground water samples collected from an openborehole
 - 7.1.4.3 If multiple samples are collected from a monitoring well or open borehole at different depths, add a designation at the end of the identification (e.g., **MW-1(Shallow)**, **MW-1(Deep)** or **MW-1 (10.0-15.0ft)**, **MW-1 (20.0-25.0ft)**; or **GW-1(Shallow)**, **GW-1(Deep)** or **GW-1 (10.0-15.0ft)**, **GW-1 (20.0-25.0ft)**)
 - 7.1.4.4 **RW** for ground water samples collected from residential water supply wells
 - 7.1.4.5 **PW** for ground water samples collected from public water supply wells
 - 7.1.4.6 For other types of wells (e.g., remedial extraction wells, non-potable process water wells, irrigation wells) use a sample identification based on the well identification.
- 7.1.5 **LE** for leachate samples
- 7.1.6 **IA** for indoor air samples
- 7.1.7 **AA** for ambient air samples
- 7.1.8 **SS** for sub-slab vapor samples
- 7.1.9 **SG** for soil gas samples
- 7.1.10 **FP** for free product samples
- 7.1.11 **WA** for solid waste samples

7.1.12 Alternative sample nomenclature may be used for site-specific circumstances (e.g., DRUM, TOTE, etc.).

7.2 Quality assurance/quality control (QA/QC) sample and blank identification consist of an abbreviation for the QA/QC sample or blank type and a consecutive sample/blank number separated by a hyphen, e.g., **FB-01** (field blank number one) unless otherwise noted. QA/QC samples/blanks and association abbreviations (**bold**) include the following:

7.2.1 Duplicate samples

7.2.1.1 **DUP** for duplicate samples, unless blind duplicates are required by the regulatory program (see 7.2.1.2). Duplicates may be numbered consecutively without reference to the sample from which the duplicate was split, e.g., **DUP-1** for a duplicate split from ground water sample MW-1, or identified by adding the suffix "DUP" to the identification of the sample from which the duplicate was split, e.g., **MW-1DUP** for a duplicate split from ground water sample MW-1.

7.2.1.2 Blind duplicates are duplicate samples, preferably split from the same container, which are numbered by the same convention as the other samples so that the laboratory does not know they are duplicates.

7.2.2 **FB** for field blanks

7.2.3 **EB** for equipment blanks

7.2.4 **TB** for trip blanks; if available, the date the trip blank was filled by the laboratory may be written in the "comments" section of the chain-of-custody form

8.0 Data and Records Management

Refer to FSOP 1.3, Field Documentation.

9.0 Quality Assurance and Quality Control

Not applicable

10.0 Attachments

None

11.0 References

FSOP 1.3, Field Documentation

Sample Custody and Handling

FSOP 1.5 (May 6, 2020)

Ohio EPA Division of Environmental Response and Revitalization

1.0 Scope and Applicability

- 1.1 This procedure describes standard practices used by the Division of Environmental Response and Revitalization (DERR) for custody and handling of environmental samples (generally water, soil, sediment, soil gas, or air) prior to receipt by a laboratory. See the U.S. EPA Sampler's Guide (October 2014) for additional information, particularly with regard to federal site assessment activities.

- 1.2 A chain of custody (COC) form documents the exchange of samples from sampling personnel to the laboratory and supports the integrity and legal defensibility of the sampling process. The COC form generally includes the following information:
 - 1.2.1 Project name and location
 - 1.2.2 Sampler's name and contact information
 - 1.2.3 Laboratory name and contact information
 - 1.2.4 Sample number/identification
 - 1.2.5 Date and time of sample collection
 - 1.2.6 Grab or composite designation
 - 1.2.7 Number and types of containers comprising a sample
 - 1.2.8 Analytical methods and preservatives
 - 1.2.9 Requested analytical turnaround time
 - 1.2.10 Notes concerning samples
 - 1.2.11 Sampler's signature
 - 1.2.12 Signatures of individuals involved in the sample transfer (except for commercial shipping personnel)
 - 1.2.13 Air bill or shipping number

- 1.3 Agency personnel are responsible for the care and custody of samples from the time of collection to the time the samples are relinquished directly to the laboratory or to a commercial shipper for transportation to the laboratory. U.S. EPA Sampler's Guide (October 2014) considers a sample "under custody" under the following conditions:
 - 1.3.1 The sample is in possession.

 - 1.3.2 The sample was in possession and then secured or sealed to prevent tampering.

 - 1.3.3 The sample was in possession when placed in a secured area.

- 1.4 Proper packaging and prompt shipment of samples is important for the following reasons:
 - 1.4.1 Protecting samples from temperature increases that may cause changes in analyte composition or concentration.
 - 1.4.2 Reducing sample degradation from exposure to ultraviolet rays.
 - 1.4.3 Reducing the chance of leaking or breaking of sample containers and exposure of field sampling or laboratory personnel to toxic substances.
 - 1.4.4 Ensuring compliance with shipping regulations.
 - 1.4.5 Minimizing the potential for sample theft or tampering.
 - 1.4.6 Ensuring that analytical holding times for samples are met.
- 1.5 This procedure is consistent with certain Contract Laboratory Program (CLP) requirements that are generally accepted practices for sample custody and handling for environmental investigations. However, it does not meet all CLP requirements. It is the responsibility of the DERR Site Investigation Field Unit (SIFU) to meet all CLP project requirements before and after field sampling activities.
- 1.6 This procedure does not apply to shipping samples that are defined as a hazardous material (also referred to as dangerous goods, see the Dangerous Goods List, Section 4.2 IATA). If shipping a suspected hazardous material always contact appropriate management for assistance. Shipping hazardous waste samples may be excluded from hazardous waste requirements under OAC 3745-51-14 (D).

2.0 Definitions

Not applicable

3.0 Health and Safety Considerations

- 3.1 Large sample coolers filled with environmental samples and ice typically weigh between 40 and 60 pounds. Always use proper lifting techniques, and if needed request assistance to avoid injuries.
- 3.2 Glass containers may break during sample handling and packing. Always handle glass containers with care and be aware of the potential for broken glass when packing or rearranging. Broken glass may cause cuts or lacerations. Seek medical attention if needed and/or use first aid kit for cuts or lacerations.

- 3.3 Strong acids or bases, e.g., HCl, HNO₃, H₂SO₄, and NaOH, are often used to preserve water samples. Skin or eye contact with preservatives or preserved samples may result in injury. Wear appropriate personnel protective equipment (e.g., gloves and eye protection) to avoid chemical burns. Use potable water to flush exposed areas and seek medical attention if needed. *(If directly exposed to a concentrated acid or base, seek medical attention immediately.)*

4.0 Procedure Cautions

- 4.1 Most environmental samples must be preserved on ice at 4°C (+/-2°C) to prevent sample degradation. Temperature-sensitive samples should be shipped same-day or next-day delivery to the laboratory.
- 4.2 Do not use “blue ice” packs for temperature preservation of environmental samples. Natural ice is more reliable for maintaining a sample temperature of 4°C (+/-2°C). Additionally, “blue ice” typically contains ingredients (e.g., propylene glycol or styrene) that could contaminate volatile organic compound (VOC) or semi-volatile organic compound (SVOC) samples if the packs leak during transportation.
- 4.3 Never place loose ice in a sample cooler being prepared for commercial shipment. If the ice melts and water leaks from the cooler during transit, shipment to the laboratory may be delayed or terminated. Always contain ice in sealable plastic bags or within a sealed heavy-duty plastic bag used as a cooler liner.
- 4.4 In limited circumstances, special handling and shipping requirements will apply to environmental samples containing concentrated preservatives. Some chemical preservatives are regulated as hazardous materials by U.S. Department of Transportation (U.S. DOT). Reference the Hazardous Materials Transportation Act (49 CFR 170-179) which provides detailed guidelines for shipping hazardous materials.
- 4.5 Each sample cooler should contain a separate COC form documenting only the samples being transported within that cooler. This practice maintains the COC for all samples in case of a lost or misrouted shipment. In addition, this practice helps prevent potential confusion when the samples are received and logged at the laboratory.
- 4.6 If shipping samples on a Friday for next-day delivery, inform the laboratory that the samples will be arriving on Saturday. Confirm the receiving address for the Saturday delivery, which may be different than the receiving address for sample delivery during weekdays. Note that some commercial shippers may also require a special air bill for Saturday delivery or “Saturday Delivery” labels on the shipping cooler.

- 4.7 If shipping samples with expedited turnaround times or analytical holding times less than seven days, e.g., unpreserved water samples for VOC analysis, contact the laboratory on the day that the samples are shipped and remind or inform them of the expedited turnaround times. Also, be aware that the holding times for some analytical methods are so short that the samples must be delivered to the laboratory via Ohio EPA staff or courier on the same day. For example, SW- 846 Method 7196A for hexavalent chromium in ground water or surface water has a 24-hour holding time. If in doubt about sample holding time requirements, contact SIFU personnel for assistance.

5.0 Personnel Qualifications

Ohio EPA personnel working at sites that fall under the scope of OSHA's hazardous waste operations and emergency response standard (29 CFR 1910.120) must meet the training requirements described in that standard.

6.0 Equipment and Supplies

- 6.1 COC forms
- 6.2 Clear tape (for securing and protecting completed labels on sample containers)
- 6.3 Custody seals
- 6.4 Custody tape
- 6.5 Duct tape (for packaging sample containers)
- 6.6 Environmental samples (in appropriate jars/containers) to be shipped
- 6.7 Large heavy-duty plastic bags (for use as sample cooler liners)
- 6.8 Ice
- 6.9 Knife or scissors
- 6.10 Packing materials (e.g., bubble wrap, foam molds, laboratory-supplied materials)
- 6.11 Pens and markers, preferably waterproof
- 6.12 Sealable plastic bags (pint to two-gallon size for sample containers, COC forms, and/or ice)
- 6.13 Shipping coolers
- 6.14 Shipping (mailing) forms for air or ground delivery (unless samples are being delivered directly to the laboratory by an Ohio EPA staff member or courier)
- 6.15 Shipping labels for package handling (including but not necessarily limited to "Fragile," "This Side Up," and "Do Not Drop")
- 6.16 Shipping/Packaging tape (for sealing shipping coolers)
- 6.17 Temperature blanks (if required by the laboratory)
- 6.18 Trip blanks (if the shipping cooler includes samples for VOC analysis)

7.0 Procedures

7.1 Sample custody and COC forms

- 7.1.1 To maintain proper custody, keep samples in sight or in a secured location, e.g., a locked vehicle or room. If samples are to be stored overnight prior to shipment to the laboratory, if storage location is not secure then the sample cooler is to be sealed with custody tape/labels to prevent tampering.
- 7.1.2 District office personnel may leave samples at the Groveport Field Office in the custody of SIFU or other Ohio EPA field staff prior to delivery to a laboratory.
- 7.1.3 Use only blue or black ink to complete COC forms.
- 7.1.4 If samples are being shipped to a state contract laboratory, contact SIFU, a District Office Laboratory Coordinator, or the contract laboratory for specific instructions on completing the contract laboratory's COC form.
- 7.1.5 If submitting samples to the Ohio EPA Division of Environmental Services (DES) laboratory, use DES COC forms. Contact DES for specific instructions on completing their COC forms.
- 7.1.6 Prior to shipping a sample cooler, review the COC form for accuracy and ensure that each sample being shipped within that cooler is properly documented on the COC form. Never include samples being shipped in other coolers. If required, include the air bill or shipping tracking number on the COC form.
- 7.1.7 Sign and date each COC form.

7.2 Sample handling (packaging and shipping)

- 7.2.1 Inspect the sample containers to be shipped for loose or improper fitting lids, damaged lids, and incomplete or illegible sample labels. Document such problems as appropriate and correct if possible. If correction is not possible, inform the District Office Site Coordinator and the SIFU Sampling Team Leader or SIFU Laboratory Coordinator.
- 7.2.2 Use clear tape to cover and protect the labels on sample containers.
- 7.2.3 Wrap glass sample containers in bubble wrap and/or use other protective shipping materials such as foam molds to help prevent container breakage.
- 7.2.4 Place glass sample containers in sealable plastic bags to contain the contents and prevent potential cross contamination of other samples if broken in transit.

- 7.2.5 Seal any drainage holes in the shipping cooler. Use only clean, dry shipping coolers.
- 7.2.6 Place two large heavy-duty plastic bags in the shipping cooler as liners, one inside of the other.
- 7.2.7 Place sample containers upright inside the inner bag. Include a trip blank if samples are being submitted for VOC analysis and a temperature blank if required by the laboratory. Place larger, heavier containers on the bottom of the shipping cooler and smaller, lighter sample containers at the top. Use additional packing material between containers to help prevent breakage. Do not overfill the cooler with sample containers and packing material. Allow at least 25% of the cooler volume for ice.
- 7.2.8 Twist the inner bag (containing samples) closed while removing excess air volume. Seal the inner bag using duct tape.
- 7.2.9 Fill the available area between the inner bag and outer bag with fresh ice.
- 7.2.10 Twist the outer bag closed and seal it using duct tape.
- 7.2.11 As an alternative to Steps 7.2.6 through 7.2.10 for small-sized or medium-sized shipping coolers, place all sample containers in sealable plastic bags and make ice packs using one-gallon or two-gallon sealable plastic bags. The ice should be double bagged to help prevent leakage into the cooler.
- 7.2.12 If shipping by common carrier, place the completed COC form in a sealable plastic bag and either tape it to the top of the sample cooler or place it in the cooler on top of the bagged sample containers. Otherwise, give the COC to the laboratory courier or hand deliver it to the laboratory with the samples. (Remember to include the air bill or shipping tracking number on the COC form if required).
- 7.2.13 Check that the cooler lid closes properly. If it does not, remove some ice and/or reconfigure the sample containers (repeat Steps 7.2.6 through 7.2.11 as necessary).
- 7.2.14 Affix a signed and dated custody seal to the closed cooler. Protect the custody seal by covering it with clear tape.
- 7.2.15 Secure the lid by circling the cooler and lid several times with shipping/packing tape. For small to medium coolers, tape the left and right sides. For large coolers, tape the midsection of the cooler in addition to the right and left sides.
- 7.2.16 Affix "Do Not Drop," "Fragile," and "This Side Up" stickers, and any other needed shipping stickers to the sides or top of the cooler.

7.2.17 Complete the air bill and/or other shipping forms. If shipping overnight on a Friday, remember to check the "Saturday Delivery" box on the form. Never check "Shipper Release" or "Signature Release" boxes. Unless otherwise instructed by the SIFU Laboratory Coordinator, do not declare a value for the cooler and always bill the receiver (the laboratory).

7.2.18 If shipping by common carrier, attach the air bill and/or other shipping forms on the top of the cooler and ship same-day or next-day delivery.

8.0 Data and Records Management

Refer to FSOP 1.3, Field Documentation.

9.0 Quality Assurance and Quality Control

Check the completed COC form for errors or omissions by comparing the sample cooler contents to the form prior to sealing the cooler for shipment.

10.0 Attachments

None

11.0 References

FSOP 1.3, Field Documentation

Hazardous Material Transportation Act, U.S. Code of Federal Regulations, 49 CFR 170-179

International Air Transportation Association, Dangerous Goods List, Section 4.2

Ohio Administrative Code OAC 3745-51-04(D)

U.S. EPA, 2014, Sampler's Guide, Contract Laboratory Program Guidance for Field Samplers, OSWER 9200.2-147, EPA 540-R-014-013

Sampling Equipment Decontamination

FSOP 1.6 (May 12, 2020)

Ohio EPA Division of Environmental Response and Revitalization

1.0 Scope and Applicability

- 1.1 This procedure describes standard practices used by the Division of Environmental Response and Revitalization (DERR) for the decontamination of sampling equipment. All equipment used to collect environmental samples should be decontaminated prior to use to avoid cross-contamination of samples, sampling personnel, or other environmental media.
- 1.2 When collecting soil samples, stainless steel pans and spoons should be used. Disposable pans and spoons should be used when heavy contamination is present. Non-disposable sampling equipment must be decontaminated either on site or preferably in a fixed-base facility such as the Ohio EPA Groveport Field Office. Use of a fixed-base facility is logistically easier, especially with regard to the containment and disposal of decontamination fluids.
- 1.3 Solvents and acids should not be used for equipment decontamination.
- 1.4 Equipment that cannot be effectively decontaminated using the procedures described in this FSOP must be disposed of properly in accordance with federal, state, and local requirements. Refer to FSOP 1.7, Investigation-Derived Wastes and Materials.
- 1.5 The procedures described herein are the minimum level of effort that should be expended for equipment decontamination.
- 1.6 This procedure applies to the decontamination of sampling equipment only. It does not apply to the decontamination of personnel, personal protective equipment (PPE), field monitoring instruments, or vehicles.

2.0 Definitions

Not applicable

3.0 Health and Safety Considerations

Proper PPE should be worn when performing decontamination procedures to avoid exposure to contaminated media, or decontamination fluids. PPE typically includes but is not limited to protective gloves, safety glasses or goggles, and protective coveralls.

4.0 Procedure Cautions

4.1 Equipment decontamination generates one or more of the following materials:

- Residual soil or sediment
- Wash and rinse water
- Materials used during the decontamination process (e.g., paper towels or plastic sheets)
- Personal protective equipment during the decontamination process (e.g., gloves or coveralls)

Generally, these materials are not hazardous and may be disposed of as non-hazardous wastes; refer to FSOP 1.7, Investigation-Derived Wastes and Materials. However, if hazardous materials or highly elevated concentrations of hazardous substances are encountered during sampling activities, the associated decontamination wastes could be hazardous wastes. To ensure proper disposal, such decontamination wastes need to be characterized in accordance with Ohio Administrative Code (OAC) 3745-51-20 through -24 (Characteristic Hazardous Wastes) or (OAC) 3745-51-30 through -35 (Listed Hazardous Wastes) to determine whether they are hazardous.

4.2 If an equipment blank is needed to evaluate the effectiveness of decontamination procedures, the field team leader should request that the blank be collected at an undisclosed time. This practice helps avoid the introduction of bias into the decontamination procedures based on anticipation of the equipment blank.

5.0 Personnel Qualifications

Ohio EPA personnel working at sites that fall under the scope of OSHA's hazardous waste operations and emergency response standard (29 CFR 1910.120) must meet the training requirements described in that standard.

6.0 Equipment and Supplies

- 6.1 Appropriate PPE
- 6.2 ASTM Type II, distilled, or reverse osmosis water
- 6.3 Detergent (non-phosphate detergent is recommended for field decontamination)
- 6.4 Clean cloths, paper towels, or disposable wipes
- 6.5 Brushes
- 6.6 Spray bottle
- 6.7 Buckets or pans
- 6.8 Plastic containers with resealable lids (to contain decontamination fluids in the field)
- 6.9 Plastic sheets (to cover the ground during field decontamination procedures)
- 6.10 Aluminum foil or sealable plastic bags (to contain decontaminated equipment)

7.0 Procedures

7.1 Decontamination procedures depend on anticipated field conditions and the nature of the investigation. Equipment may be decontaminated in the field or at a fixed-base facility (e.g., Ohio EPA's Groveport Field Office). Decisions regarding the scope and location of equipment decontamination should be made during the preparation of the project work plan and in consultation with the Site Investigation Field Unit (SIFU).

7.2 Fixed-base facility decontamination procedures:

7.2.1 Remove excess soil or sediment contamination from the equipment while in the field. Remove as much residue as practically possible to minimize investigation derived waste and to keep the wash water as clean as possible.

7.2.2 Disassemble the equipment if necessary, for proper decontamination.

7.2.3 Wash the equipment with tap water and detergent.

7.2.4 Rinse the equipment with tap water.

7.2.5 Rinse the equipment a second time with ASTM Type II, distilled, or reverse osmosis water.

7.2.6 Allow the equipment to air dry or dry it with a clean cloth or paper towel.

7.2.7 If the equipment is not to be used immediately, wrap in aluminum foil or place in sealable plastic bags.

7.3 Field decontamination procedures:

7.3.1 Set up the decontamination area away from potential sources of dust, vapors, or other contaminants. Decontamination supplies should be placed on a clean sheet of plastic to prevent direct contact with the ground or other surfaces that may contain contaminants.

7.3.2 Remove excess soil or sediment contamination from the equipment.

7.3.3 Disassemble the equipment, if necessary, for proper decontamination.

7.3.4 Wash the equipment with ASTM Type II, distilled, or reverse osmosis water and detergent.

7.3.5 Rinse the equipment with ASTM Type II, distilled, or reverse osmosis water.

7.3.6 Dry the equipment with a clean cloth or paper towel.

7.3.7 If the equipment is not to be used immediately, wrap it in aluminum foil or place in a sealable plastic bag

7.4 All waste materials generated during equipment decontamination including rinse water (See Section 4.1) must be containerized and evaluated for proper disposal, regardless of whether the decontaminated equipment was used to sample media known to contain hazardous substances or hazardous wastes.

7.5 Waste materials generated during equipment decontamination are investigation derived waste and should be disposed of in accordance with FSOP 1.7, Investigation Derived Wastes.

8.0 Data and Records Management

Refer to FSOP 1.3, Field Decontamination.

9.0 Quality Assurance and Quality Control

An equipment blank may be required to evaluate the effectiveness of decontamination procedures.

10.0 Attachments

None

11.0 References

FSOP 1.3, Field Decontamination

FSOP 1.7, Investigation Derived Wastes

Ohio Administrative Code 3745-51-20 through -24

Ohio Administrative Code 3745-51-30 through -35

Investigation Derived Waste

FSOP 1.7 (May 21, 2020)

Ohio EPA Division of Environmental Response and Revitalization

1.0 Scope and Applicability

1.1 Investigation derived waste (IDW) is a generic term used to describe a variety of waste materials generated during sampling and other site assessment activities. IDW typically includes environmental media such as soil boring cores or monitoring well purge water, used disposable sampling equipment, used personal protective equipment (PPE), decontamination fluids and used packaging materials. It may include a variety of waste materials regulated for disposal under federal, state or local regulations, including municipal solid waste (MSW), industrial and residual solid waste, infectious waste, construction and demolition debris, hazardous waste, petroleum waste, coal mine wastes, lime mining wastes, low-level radioactive wastes or wastes regulated by the Toxic Substances Control Act (TSCA) including polychlorinated biphenyls (PCBs) or asbestos-containing materials (ACM).

1.2 Management and disposal of IDW generated during DERR site assessments will be consistent with U.S. EPA guidance (see References below) and meet all applicable regulations. In the event that petroleum, hazardous, TSCA, infectious or low-level radioactive IDW is generated, DERR will comply with the regulations governing the management and disposal of these solid and/or liquid wastes. If IDW is non-petroleum, non-hazardous, non-TSCA, non-infectious and non-radioactive, DERR will manage and dispose of the solid materials as municipal solid waste regardless of whether or not the IDW is an MSW-regulated waste, e.g., unwanted soil cores or coal mine waste. DERR will manage and dispose of non-petroleum, non-hazardous, non-TSCA, non-infectious and non-radioactive fluids as sanitary wastewater.

1.3 When evaluating whether IDW may be petroleum, hazardous, TSCA, infectious or radioactive, DERR field personnel are expected to use the following resources, if available, before or during field work activities:

- Knowledge of site history, industrial processes, material handling and waste releases or disposal practices
- Field evidence (e.g., visual appearance of contamination or waste materials; labeling, or type of discarded containers, etc.)
- Field screening instrument (e.g., photoionization detector) results

These criteria represent the best information that is readily available to DERR management and staff for the evaluation of IDW regulatory status.

Therefore, use of these criteria constitutes both a good faith effort and due diligence on the part of DERR to properly manage (contain, handle, store and/or transport) and/or dispose of IDW.

- 1.4 This FSOP is applicable to site assessment activities conducted by DERR. It does not apply to the following situations:
- Management or disposal of remediation wastes (e.g., removal of soil or ground water as a site cleanup remedy)
 - Management or disposal of IDW generated from site assessment activities performed by Ohio EPA level-of-effort (LOE) contractors
 - Management or disposal of IDW generated from emergency response activities
 - Management or disposal of ACM - If IDW is known or suspected to include ACM, contact and defer to the Ohio EPA Division of Air Pollution Control for assistance with IDW management and disposal.
 - Management or disposal of infectious wastes - If infectious wastes (e.g., medical waste containers with syringes, needles and blood-contaminated waste materials) are encountered during sampling or other site assessment activities, contact and defer to the Ohio EPA Division of Materials and Waste Management (DMWM) for assistance with IDW management and disposal. Attachment A includes a detailed description of the variety of materials that are defined as infectious waste.
 - Management or disposal of low-level radioactive wastes - If low-level radioactive IDW is generated during site assessment activities, contact and defer to the Ohio Department of Health (ODH) for assistance with IDW management and disposal.

2.0 Definitions

- 2.1 For the purposes of the FSOP, “**non-hazardous waste**” means waste which consists of MSW, industrial or residual solid wastes, construction and demolition debris, mining wastes or other unwanted materials that are not defined as regulatory wastes such as soil or sediment, and is not petroleum, hazardous, TSCA-regulated, infectious or radioactive.
- 2.2 For the purposes of this FSOP, “**hazardous waste**” means any waste that contains or is otherwise contaminated with a listed hazardous waste at any concentration (including previously disposed or spilled hazardous waste) or that exhibits a characteristic of hazardous waste.
- 2.3 Soil is considered a regulated waste only when contaminated by hazardous waste, petroleum waste or other regulated wastes.
- 2.4 Refer to Attachment A for regulatory definitions of wastes and associated materials.

3.0 Health and Safety Considerations

- 3.1** IDW management (handling and storage) and disposal activities must be protective of human health, safety and the environment and must be performed in accordance with all applicable regulations.
- 3.2** Use appropriate PPE when handling IDW. Refer to the site-specific work plan (SSWP) and health and safety plan (HASP) for required PPE.
- 3.3** Conduct air monitoring as required when managing IDW. Refer to the SSWP for air monitoring applicability and to Table 1 of FSOP 1.1, Initial Site Entry for air monitoring action levels.
- 3.4** Exercise extra caution at landfills, construction and demolition debris facilities, or other waste disposal areas that may contain unique hazards such as sharps, medical wastes, chemical containers or ACM.
- 3.5** Always assume that infectious wastes encountered during site assessment activities are untreated, even within the disposal area of an MSW landfill facility.

4.0 Procedure Cautions

- 4.1** Every attempt should be made to seek a suitable location for disposal of decontamination water or ground water from monitoring wells. Local publicly owned treatment works (POTW) facilities often will accept purge water but may require analytical results before disposal can occur. On-site treatment facilities may often be a suitable option for disposing of water. If a small quantity (<15 gallons) of water is generated and no other options are available, water may occasionally be transported back to the Ohio EPA's Groveport Field Office or an Ohio EPA district office for disposal.
- 4.2** If ground water is known or assumed (with reasonable certainty) to be uncontaminated, then it may be suitable to dispose of the water on the ground.
- 4.3** Never dispose of monitoring well purge water or decontamination fluids on the ground if the contaminants or concentrations are unknown. Waste fluids must be containerized and transported to an appropriate disposal facility unless an alternative disposal option is available at the site or the facility being investigated, or the fluids must be stored on site until appropriate disposal can be arranged.
- 4.4** IDW containing soil and/or debris must be transported back to the Ohio EPA's Groveport Field Office or an Ohio EPA district office for disposal unless an alternative disposal option is available at the site or facility being investigated.
- 4.5** Samples may be excluded from hazardous waste regulations during transport to the laboratory and back to the sample collector, during storage in the laboratory before and after analysis, and during storage for evidence in enforcement cases. See OAC rule 3745-51-04

5.0 Equipment and Supplies

- 5.1 PPE
- 5.2 Heavy duty plastic bags
- 5.3 Sealable plastic buckets or other containers suitable for containing fluids
- 5.4 Department of Transportation (DOT) approved drums
- 5.5 Tools to open and close drums
- 5.6 Drum or container labels
- 5.7 Drum dolly or hoist
- 5.8 Duct tape
- 5.9 Plastic sheeting

6.0 Procedures

6.1 General Procedures for IDW Management and Disposal

- 6.1.1 Before performing field work, review the site history and available field screening, sampling, and analytical data or records of previous waste listing classification to evaluate the types of wastes and contamination likely to be encountered. Include this information in the SSWP, especially if the site is subject to the Resource Conservation and Recovery Act (RCRA) hazardous waste regulations. Use this information to anticipate the types of IDW likely to be generated during sampling and other site assessment activities. Evaluate management and disposal options based on the types and amounts of IDW likely to be generated.
- 6.1.2 Use sampling and other site assessment procedures that minimize the amount of IDW generated during sampling and investigation activities whenever possible. For example, using low-flow sampling techniques to collect ground water samples typically generates less monitoring well purge water than using bailers to collect ground water samples.
- 6.1.3 Evaluate if the IDW may be petroleum, hazardous, TSCA-regulated, infectious or radioactive based on the following site and field data:
 - Knowledge of site history, industrial processes, material handling and waste releases or disposal practices
 - Field evidence (e.g., visual appearance of contamination or waste materials; labeling, or type of discarded containers, etc.)
 - Field screening instrument results

These criteria represent the best information that is readily available to DERR management and staff for the evaluation of IDW regulatory status. Therefore, use of these criteria constitutes both a good faith effort and due diligence on the part of DERR to properly manage and/or dispose of IDW.

- 6.1.4 If IDW is suspected to be hazardous (based on good faith effort and due diligence), containerize, label, date, and retain the waste material until results of more definitive testing and evaluation are available to determine the appropriate disposal procedures.
- 6.1.5 If IDW is suspected to be hazardous due to mixture with or contamination from a listed hazardous waste, a site-specific contained-in decision may be appropriate for waste management. To make a contained-in decision, a project-specific tasking request will be submitted to the DERR Engineering & Risk Assessment Support Unit (ERAS) supervisor following the Contained-In Request Procedure (Attachment C) and consult with the DERR RCRA manager as necessary.
- 6.1.6 As a general work practice, manage and dispose of disposable sampling equipment and PPE in the same manner as IDW generated from the media being sampled or otherwise investigated.
- 6.1.7 If permissible and protective of human health and the environment, use facility equipment and procedures for containerizing and disposing non-hazardous IDW.

6.2 Management and Disposal of Non-Hazardous Wastes

- 6.2.1 Manage and dispose of IDW solids that are not regulated as petroleum, hazardous, TSCA, infectious, or radioactive waste as MSW. Such non-hazardous IDW may include, but is not limited to the following materials:
 - Used PPE, used disposable sampling equipment and used packaging materials
 - Soil (soil is not a regulated waste unless contaminated by hazardous waste, petroleum waste or other regulated wastes)
 - Construction and demolition debris
 - Sediment containing coal mining or lime mining wastes
- 6.2.2 Manage monitoring well purge water, decontamination fluids and other IDW liquids that are not regulated as petroleum, hazardous, TSCA-regulated, infectious, or radioactive waste as sanitary wastewater that can be disposed of in a POTW.
- 6.2.3 Containerize non-hazardous IDW solids in heavy duty plastic bags, buckets, other containers or drums.
- 6.2.4 Containerize non-hazardous IDW liquids in sealable buckets, other sealable containers or drums.
- 6.2.5 Dispose of non-hazardous IDW solids as MSW in a solid waste dumpster. Dispose of non-hazardous IDW liquids in the POTW as sanitary wastewater with permission from the POTW.

- 6.2.6 If permissible and protective of human health and the environment, solid or liquid non-hazardous IDW may be disposed of as MSW or sanitary wastewater at the site or facility being investigated.
- 6.2.7 Stabilize IDW consisting of semi-solid or sludge-like materials (e.g., contaminated sediment) with granular bentonite or other inert absorbent material before disposing of it as solid waste. (Sludge-like materials should not be disposed of as solid waste unless it can pass the Paint Filter Liquids Test, SW-846 Method 9095).

6.3 Management and Disposal of Petroleum Contaminated IDW

- 6.3.1 If petroleum contaminated IDW solids are not visibly contaminated with free product, dispose of the IDW as MSW unless it is known or suspected to be a characteristic hazardous waste (if so, refer to Sections 6.3.2 and 6.4 below). U.S. EPA 2009 (Hazardous Waste Characteristics, A User-Friendly Reference Document) provides guidance on the RCRA hazardous waste characteristic regulations.
- 6.3.2 If petroleum contaminated IDW solids are visibly contaminated with free product, consult with the local MSW disposal facility regarding required pre-disposal testing. Required testing may include the Toxicity Characteristic Leaching Procedure (TCLP), SW-846 Method 1311 for benzene and other volatile petroleum constituents, Ignitability and Ignitability of Solids, SW-846 Methods 1010A, 1020B and 1030 or the Paint Filter Liquids Test, SW-846 Method 9095.
- 6.3.3 If IDW liquid consisting of free-phase petroleum product and water is generated during a site assessment (e.g., monitoring well purge water containing free-phase gasoline), contact and defer to the Office of Emergency Response (OER) Level-of-Effort (LOE) Coordinator for assistance with IDW management and disposal. IDW liquids containing free-phase petroleum products may be characteristic hazardous wastes (refer to Section 6.4)

6.4 Management and Disposal of Hazardous IDW

- 6.4.1 If IDW is suspected to be hazardous based on the three criteria discussed in Section 6.1.3 or known to contain listed hazardous waste, contact and defer to the OER LOE Coordinator or the DERR RCRA manager for assistance with IDW management and disposal. Hazardous Waste Characteristics, A User-Friendly Reference Document (U.S. EPA 2009) provides guidance on the RCRA hazardous waste characteristic regulations.

- 6.4.2 When IDW is generated at a site that is not secured, or if potential spills or releases from the IDW containers exist, IDW solids or liquids suspected to be characteristic hazardous wastes based on toxicity, ignitability, or corrosivity may be temporarily stored in a secured location at the Groveport Field Office pending the results of testing (TCLP, SW-846 Method 1311; Ignitability SW-846 Methods 1010A, 1020B and (1030 the test results for this method cannot be used to directly classify a waste as a D001 ignitable hazardous waste); and appropriate corrosivity testing such as SW- 846 Method 9040C or 9041A). Wastes that are suspected or anticipated to exhibit the characteristic of reactivity may be too dangerous for DERR staff to handle, transport or store. Contact and defer to the OER LOE Coordinator for guidance on managing potentially reactive IDW.
- 6.4.3 If soil samples are managed and disposed as hazardous waste, then any grossly contaminated disposable sampling equipment and PPE used to collect and handle to soil cores will be managed and disposed as hazardous waste.

6.5 Management and Disposal of Toxic Substances Control Act IDW

- 6.5.1 Wastes regulated under the TSCA include polychlorinated biphenyls (PCBs) and asbestos-containing materials (ACM).
- 6.5.2 IDW consisting of PCB-containing soil, sediment, or soil-like wastes may be temporarily stored at the Groveport Field Office pending the results of PCB analysis. Contact and defer to the OER LOE Coordinator for assistance with IDW management and disposal.

7.0 Data and Records Management

Refer to FSOP 1.3, Field Documentation.

8.0 Attachments

Attachment A, Regulatory Definitions for Wastes and Associated Materials

Attachment B, Contained-In Decision Request Procedure

Attachment C, Maximum Concentrations of Contaminants for the Toxicity Characteristic

9.0 References and Regulatory Contact Information

FSOP 1.1, Initial Site Entry

FSOP 1.3, Field Documentation

FSOP 1.6, Sampling Equipment Decontamination

OAC 1301:7-9, BUSTR Regulations

OAC 1501:13-1, ODNR Coal Mining Regulations

OAC 1501:14-1, ODNR Lime Mining Regulations

OAC 3701:1-38, ODH General Radiation Protection Standards for Sources of Radiation

OAC 3745-20, Ohio EPA Asbestos Emission Control Regulations

OAC 3745-27, Ohio EPA Solid and Infectious Waste Regulations

OAC 3745-29, Ohio EPA Industrial Waste Regulations

OAC 3745-30, Ohio EPA Residual Waste Regulations

OAC 3745-50 through 52, Ohio EPA Hazardous Waste Management Standards

OAC 3745-400 Ohio EPA Construction and Demolition Debris Regulations

Ohio EPA Division of Air Pollution Control: (614) 644-2270, -2271 or -2272

Ohio EPA Division of Materials and Waste Management: (614) 644-2621

Ohio EPA Groveport Field Office: (614) 836-8800

OER LOE Coordinator: (614) 836-8761

DERR Site Field Investigation Unit: (614) 644-2305

Ohio Department of Health Bureau of Radiation Protection: (614) 644-2727 (main) or
(614) 722- 7221 (for emergencies)

SW-846 Methods 1010A, 1020B and 1030, Ignitability of Solids

SW-846 Method 1311, Toxicity Characteristic Leaching Procedure

SW-846 9040C, pH Electrometric Measurement

SW-846 Method 9095, Paint Filter Liquids Test

U.S. EPA, 2009, Hazardous Waste Characteristics, A User-Friendly Reference Document:
Materials Recovery and Waste Management Division, Office of Resource Conservation and
Recovery

U.S. EPA, January 1992, Guide to Management of Investigation-Derived Wastes: Office of Solid
Waste and Emergency Response, 9345.3-03FS

U.S. EPA, July 3, 2014, Management of Investigation-Derived Waste (SESD Operating
Procedure): U.S. EPA Region 4, Science and Ecosystem Support Division. SESDPROC-
202-R3

Toxic Substances Control Act, 15 U.S.C. §2601 et seq. (1976) (*refer to 40 CFR 761 U.S. EPA
PCB Regulations*)

ATTACHMENT A

Regulatory Definitions for Wastes and Associated Materials

Asbestos-Containing Waste Materials [OAC 3745-20-01(B)(4)]

"Asbestos-containing waste materials" means mill tailings or any waste that contains commercial asbestos and is generated by a source subject to the provisions of this chapter. This term includes filters from control devices, friable asbestos-containing material, and bags or other similar packaging contaminated with commercial asbestos. As applied to demolition and renovation operations, this term also includes regulated asbestos-containing material waste and materials contaminated with asbestos including disposable equipment and clothing.

Clean Hard Fill [OAC 3745-400-01(E)]

"Clean hard fill" means construction and demolition debris which consists only of reinforced or nonreinforced concrete, asphalt concrete, brick, block, tile, and/or stone which can be reutilized as construction material. Brick in clean hard fill includes but is not limited to refractory brick and mortar. Clean hard fill does not include materials contaminated with hazardous wastes, solid wastes, or infectious wastes.

Coal Mine Waste [OAC 1501:13-1-02(W)]

"Coal mine waste" means coal processing waste and underground development waste.

Construction and Demolition Debris [OAC 3745-400-01(F)]

"Construction and demolition debris" or "debris" means those materials resulting from the alteration, construction, destruction, rehabilitation, or repair of any manmade physical structure, including, without limitation, houses, buildings, industrial or commercial facilities, or roadways. "Construction and demolition debris" does not include materials identified or listed as solid wastes, infectious wastes, or hazardous wastes pursuant to Chapter 3734 of the Revised Code and rules adopted under it; or materials from mining operations, nontoxic fly ash, spent nontoxic foundry sand, and slag; or reinforced or nonreinforced concrete, asphalt, building or paving brick, or building or paving stone that is stored for a period of less than two years for recycling into a usable construction material.

For the purpose of this definition, "materials resulting from the alteration, construction, destruction, rehabilitation, or repair of any manmade physical structure," are those structural and functional materials comprising the structure and surrounding site improvements, such as brick, concrete and other masonry materials, stone, glass, wall coverings, plaster, drywall, framing and finishing lumber, roofing materials, plumbing fixtures, heating equipment, electrical wiring and components containing no hazardous fluids or refrigerants, insulation, wall-to-wall carpeting, asphaltic substances, metals incidental to any of the above, and weathered railroad ties and utility poles.

"Materials resulting from the alteration, construction, destruction, rehabilitation, or repair" do not include materials whose removal has been required prior to demolition, and materials which are otherwise contained within or exist outside the structure such as solid wastes, yard wastes, furniture, and appliances. Also excluded in all cases are liquids including

containerized or bulk liquids, fuel tanks, drums and other closed or filled containers, tires, and batteries.

Hazardous Waste [OAC 3745-50-10(A)(54)]

"Hazardous waste" means a hazardous waste as defined in rule 3745-51-03 of the Administrative Code. *(When attempting to determine whether or not a material is a hazardous waste, please request assistance from the Division of Environmental Response and Revitalization. The regulatory definition of hazardous waste is complex and includes numerous exclusions per OAC 3745-51-04. Accurate characterization of hazardous waste requires specialized knowledge of the hazardous waste rules.)*

Industrial Solid Waste [OAC 3745-29-01(A)]

"Industrial solid waste" or "industrial waste" means a type of solid waste generated by manufacturing or industrial operations and includes, but is not limited to, solid waste resulting from the following manufacturing processes: electric power generation; fertilizer/agricultural chemicals; food and food-related products/by-products; inorganic chemicals; iron and steel manufacturing; leather and leather products; nonferrous metals manufacturing; plastics and resins manufacturing; pulp and paper industry; rubber and miscellaneous plastic products; stone, glass, clay and concrete products; textile manufacturing; and transportation equipment. "Industrial solid waste" does not include solid wastes generated by commercial, agricultural, or community operations. Industrial solid wastes may be disposed in a licensed sanitary landfill facility, a licensed industrial waste landfill facility, or in a licensed residual waste landfill facility, provided that the class number for the residual waste landfill facility is not greater than the class number necessary for that residual waste as determined by the residual waste characterization and landfill classification in accordance with rules 3745-30-03 and 3745-30-04 of the Administrative Code.

Industrial Waste [ORC 6111.01(C)]

"Industrial waste" means any liquid, gaseous, or solid waste substance resulting from any process of industry, manufacture, trade, or business, or from the development, processing, or recovery of any natural resource, together with such sewage as is present.

Infectious Waste [OAC 3745-27-01(I)(6)]

"Infectious wastes" includes all of the following substances or categories of substances:

- (a) Cultures and stocks of infectious agents and associated biologicals, including, without limitation, specimen cultures, cultures and stocks of infectious agents, wastes from production of biologicals, and discarded live and attenuated vaccines.
- (b) Laboratory wastes that were, or are likely to have been, in contact with infectious agents that may present a substantial threat to public health if improperly managed.
- (c) Pathological wastes, including, without limitation, human and animal tissues, organs, and body parts, and body fluids and excreta that are contaminated with or are likely to be contaminated with infectious agents, removed or obtained during surgery or autopsy or for diagnostic evaluation, provided that, with regard to pathological wastes from animals, the animals have or are likely to have been exposed to a zoonotic or infectious agent.
- (d) Waste materials from the rooms of humans, or the enclosures of animals, that have been isolated because of diagnosed communicable disease that are likely to transmit

infectious agents. Also included are waste materials from the rooms of patients who have been placed on blood and body fluid precautions under the universal precaution system established by the "Centers for Disease Control" in the public health service of the United States department of health and human services, if specific wastes generated under the universal precautions system have been identified as infectious wastes by rules referred to in paragraph (I)(6)(h) of this rule.

- (e) Human and animal blood specimens and blood products that are being disposed of, provided that, with regard to blood specimens and blood products from animals, the animals were or are likely to have been exposed to a zoonotic or infectious agent. "Blood products" does not include patient care waste such as bandages or disposable gowns that are lightly soiled with blood or other body fluids, unless such wastes are soiled to the extent that the generator of the wastes determines that they should be managed as infectious waste.
- (f) Contaminated carcasses, body parts, and bedding of animals that were intentionally exposed to infectious agents from zoonotic or human diseases during research, production of biologicals, or testing of pharmaceuticals, and carcasses and bedding of animals otherwise infected by zoonotic or infectious agents that may present a substantial threat to public health if improperly managed.
- (g) Sharp wastes used in the treatment, diagnosis, or inoculation of human beings or animals or that have, or are likely to have, come in contact with infectious agents in medical, research, or industrial laboratories, including, without limitation, hypodermic needles and syringes, scalpel blades, and glass articles that have been broken. Such wastes are hereinafter in this chapter referred to as "sharp infectious waste" or "sharps."
- (h) Any other waste materials generated in the diagnosis, treatment, or immunization of human beings or animals, in research pertaining thereto, or in the production of testing of biologicals, that the public health council created in section 3701.33 of the Revised Code, by rules adopted in accordance with Chapter 119. of the Revised Code, identifies as infectious wastes after determining that the wastes present a substantial threat to human health when improperly managed because they are contaminated with, or are likely to be contaminated with, infectious agents.
- (i) Any other waste materials the generator designates as infectious waste.

Lime Mining Waste [OAC 1501:14-1-01(FF)]

"Lime Mining Wastes" means residual solid or semisolid materials generated from lime or limestone mining and processing operations, including, without limitation, lime kiln dust, scrubber sludge from kiln operations, lime or limestone materials not meeting product specification, lime hydrating materials, and other lime or limestone mining, processing, or calcining materials associated with lime or limestone mining or processing. "Lime Mining Wastes" does not include materials generated for the manufacture of cement.

Low-Level Radioactive Waste [OAC 3701:1-38-01(A)(175)]

"Waste" means those low-level radioactive wastes containing source, special nuclear, or byproduct material that are acceptable for disposal in a land disposal facility. For the purposes of this definition, low-level radioactive waste means radioactive waste not classified as high-level radioactive waste, transuranic waste, spent nuclear fuel, or byproduct material as defined in paragraphs (A)(26)(b), (A)(26)(c), and (A)(26)(d) of this rule.

Other Wastes [ORC 6111.01(D)]

“Other wastes” means garbage, refuse, decayed wood, sawdust, shavings, bark, and other wood debris, lime, sand, ashes, offal, night soil, oil, tar, coal dust, dredged or fill material, or silt, other substances that are not sewage, sludge, sludge materials, or industrial waste, and any other “pollutants” or “toxic pollutants” as defined in the Federal Water Pollution Control Act that are not sewage, sludge, sludge materials, or industrial waste.

Petroleum [OAC 1301:7-9-02(B)(44)]

“Petroleum” means petroleum, including crude oil or any fraction thereof that is a liquid at the temperature of sixty degrees Fahrenheit and the pressure of fourteen and seven-tenths pounds per square inch absolute. The term includes, without limitation, motor fuels, jet fuels, distillate fuel oils, residual fuel oils, lubricants, petroleum solvents, and used oils.

Petroleum Contaminated Soil [OAC 1301:7-9-16(B)(8)]

“Petroleum contaminated soil (PCS)” means soil that contains chemical(s) of concern in concentrations that exceed one or more of the re-use action levels in Table 1 found in paragraph (D)(1) of this rule and excludes soil defined as hazardous waste.

Residual Solid Waste [OAC 3745-30-01(B)]

"Residual solid waste" or "residual waste" is a type of solid waste and means:

- (1) The following wastes generated by fuel burning operations which are regulated by rule 3745-17-10 of the Administrative Code and which burn as fuel primarily coal: air pollution control wastes, water pollution control wastes, and other wastes with similar characteristics which are approved by the director or his authorized representative.
- (2) The following wastes generated from foundry operations: air pollution control dust, wastewater treatment plant sludge, unspent foundry sand, spent foundry sand, and other foundry wastes with similar characteristics which are approved by the director or his authorized representative.
- (3) The following wastes generated from pulp and papermaking operations: wastewater treatment plant sludges, lime mud, lime grit, sawdust, wood chips, bark, hydropulper rejects, and other pulp and papermaking wastes with similar characteristics which are approved by the director or his authorized representative.
- (4) The following wastes generated from steelmaking operations: air pollution control dust, wastewater treatment plant sludges, dust from steel processing and finishing operations, water softening sludge, flux material, and other steelmaking wastes with similar characteristics which are approved by the director or his authorized representative.
- (5) The following wastes generated from gypsum processing plant operations: gypsum wallboard waste, paper surface preparation dust, wastewater treatment plant sludge, and other gypsum processing wastes with similar characteristics which are approved by the director or his authorized representative.
- (6) The following wastes generated from lime processing operations: air pollution control dust and/or sludge, and other lime processing wastes with similar characteristics which are approved by the director or his authorized representative.

- (7) The following wastes generated from Portland cement operations: air pollution control dust and other processing wastes with similar characteristics which are approved by the director or his authorized representative.

Other Wastes [ORC 6111.01(B)]

“Sewage” means any liquid waste containing sludge, sludge materials, or animal or vegetable matter in suspension or solution, and may include household wastes as commonly discharged from residences and from commercial, institutional, or similar facilities.

Other Wastes [ORC 6111.01(N)]

“Sludge” means sewage sludge and a solid, semi-solid, or liquid residue that is generated from an industrial wastewater treatment process and that is applied to land for agronomic benefit. “Sludge” does not include ash generated during the firing of sludge in a sludge incinerator, grit and screening generated during preliminary treatment of sewage in a treatment works, animal manure, residue generated during treatment of animal manure, or domestic septage.

Other Wastes [ORC 6111.01(O)]

“Sludge materials” means solid, semi-solid, or liquid materials derived from sludge and includes products from a treatment works that result from the treatment, blending, or composting of sludge.

Solid Waste [OAC 3745-27-01(S)(23)]

"Solid waste" means such unwanted residual solid or semisolid material, including but not limited to, garbage, scrap tires, combustible and noncombustible material, street dirt and debris, as results from industrial, commercial, agricultural, and community operations, excluding earth or material from construction, mining, or demolition operations, or other waste materials of the type that normally would be included in demolition debris, nontoxic fly ash and bottom ash, including at least ash that results from combustion of coal, biomass fuels, and ash that results from the combustion of coal in combination with scrap tires where scrap tires comprise not more than fifty percent of heat input in any month, spent nontoxic foundry sand, and slag and other substances that are not harmful or inimical to public health, and includes, but is not limited to, garbage, scrap tires, combustible and noncombustible material, street dirt, and debris. Solid waste does not include any material that is an infectious waste or a hazardous waste.

Toxic Waste [Toxic Substances Control Act, 15 U.S.C. §2601 et seq. (1976)]

The Toxic Substances Control Act (TSCA) addresses the production, importation, use, and disposal of specific chemicals including polychlorinated biphenyls (PCBs), asbestos, radon, and lead-based paint.

ATTACHMENT B

Maximum Concentrations of Contaminants for the Hazardous Waste Toxicity Characteristic (OAC 3745-51-24)			
EPA Hazardous Waste Number	Contaminant	CAS ¹ Number	Regulatory Level (mg/L)
D004	Arsenic	7440-38-2	5.0
D005	Barium	7440-39-3	100.0
D018	Benzene	71-43-2	0.5
D006	Cadmium	7440-43-9	1.0
D019	Carbon Tetrachloride	56-23-5	0.5
D020	Chlordane	57-74-9	0.03
D021	Chlorobenzene	108-90-7	100.0
D022	Chloroform	67-66-3	6.0
D007	Chromium	7440-47-3	5.0
D023	o-Cresol	95-48-7	200.0 ³
D024	m-Cresol	108-38-4	200.0 ³
D025	p-Cresol	106-44-5	200.0 ³
D026	Cresol	NA	200.0 ³
D016	2,4-D	94-75-7	10.0
D027	1,4-Dichlorobenzene	106-46-7	7.5
D028	1,2-Dichloroethane	107-06-2	0.5
D029	1,1-Dichloroethylene	75-35-4	0.7
D030	2,4-Dinitrotoluene	121-14-2	0.13 ²
D012	Endrin	72-20-8	0.02
D031	Heptachlor (and its epoxide)	76-44-8	0.008
D032	Hexachlorobenzene	118-74-1	0.13 ²
D033	Hexachlorobutadiene	87-68-3	0.5
D034	Hexachloroethane	67-72-1	3.0

ATTACHMENT B

Maximum Concentrations of Contaminants for the Hazardous Waste Toxicity Characteristic (OAC 3745-51-24)			
EPA Hazardous Waste Number	Contaminant	CAS¹ Number	Regulatory Level (mg/L)
D008	Lead	7439-92-1	5.0
D013	Lindane	58-89-9	0.4
D009	Mercury	7439-97-6	0.2
D014	Methoxychlor	72-43-5	10.0
D035	Methyl ethyl ketone	78-93-3	200.0
D036	Nitrobenzene	98-95-3	2.0
D037	Pentachlorophenol	87-86-5	100.0
D038	Pyridine	110-86-1	5.0 ²
D010	Selenium	7782-49-2	1.0
D011	Silver	7440-22-4	5.0
D039	Tetrachloroethylene	127-18-4	0.7
D015	Toxaphene	8001-35-2	0.5
D040	Trichloroethylene	79-01-6	0.5
D041	2,4,5-Trichlorophenol	95-95-4	400.0
D042	2,4,6-Trichlorophenol	88-06-2	2.0
D017	2,4,5-TP (Silvex)	93-72-1	1.0
D043	Vinyl Chloride	75-01-4	0.2

Footnotes:

1. Chemical Abstracts Service number
2. Quantitation limit is greater than the calculated regulatory level. The quantitation limit therefore becomes the regulatory level.
3. If o-, m- and p-Cresol concentrations cannot be differentiated, the total cresol (D026) concentration is used. The regulatory level for total cresol is 200.0 mg/L.

ATTACHMENT C

Contained-In Decision Request Procedure

Background:

Listed hazardous waste and materials mixed with or contaminated by listed hazardous waste have special handling and management obligations that must be met by facilities, contractors and government officials, including Ohio EPA. A contained-in decision obtained through Ohio EPA's RCRA program allows media or debris contaminated by a listed hazardous waste to be managed as a non-hazardous waste if certain conditions are met. Contained-in decisions are made by using conservative risk assessment of the contaminated media or debris in a site-specific scenario to determine if the contaminated media or debris no longer requires management as a listed hazardous waste. If the contained-in decision is granted, the media or debris can be managed as non-hazardous waste following Ohio EPA's solid waste rules.

Contained-in decisions are primarily applicable to contaminated media, with media being defined as a naturally occurring material (e.g., soil, sediment, ground water and surface water). If media/contaminated media are mixed with other materials, generally Ohio EPA would describe this mixture as a contaminated media (as opposed to waste or debris) if it is made up of 50% or more of the naturally occurring media.

Hazardous debris includes items such as used personal protective equipment, used disposable sampling equipment, construction and demolition debris and other materials that are mixed or contaminated with listed hazardous waste. OAC rule 3745-270-45 essentially provides a contained-in decision for hazardous debris by allowing the hazardous waste generator to treat the debris using one of the treatment technologies provided in Table 1 of the rule (Alternative Treatment Standards for Hazardous Debris). Generally, the treatment technologies provide physical removal of any listed hazardous waste or media. Treated hazardous debris is no longer considered to be listed hazardous waste and is not required to be managed as hazardous waste unless the treatment was an immobilization technology. Be aware that any residue removed from the debris during treatment is still considered listed hazardous waste and needs to be handled accordingly.

Procedure:

Provide the following supporting information when requesting a contained-in decision for contaminated media. Please be as specific and detailed as possible.

- 1) Name
- 2) Division/district
- 3) Site name and location
- 4) Site history and information related to listed hazardous waste (listed hazardous waste codes, historical IDW management, etc.)
- 5) Current project and all potentially listed hazardous waste media or debris to be managed (expected volume of listed hazardous waste media or debris to be managed, planned management of media or debris, etc.)
- 6) Projected date of project
- 7) Expected concentrations in potentially listed hazardous waste media or debris to be managed

Forward the request and supporting information and submit the request to DERR ERAS and consult with the DERR RCRA manager as necessary to complete the request.

Boring and Monitoring Well Decommissioning

FSOP 1.9 (May 20, 2020)

Ohio EPA Division of Environmental Response and Revitalization

1.0 Scope and Applicability

Borings that are drilled for sampling or subsurface exploratory purposes or monitoring wells that are no longer needed for site assessment purposes must be decommissioned [Ohio Administrative Code (OAC) 3701-28-07, 3745-9-03 and 3745-9-10]. Ohio EPA's Technical Guidance Manual (TGM) for Hydrogeologic Investigations and Ground Water Monitoring provides appropriate guidance for boring and monitoring well decommissioning (Chapter 9, Sealing Abandoned Monitoring Wells and Boreholes). Also refer to State of Ohio, Regulations and Technical Guidance for Sealing Unused Water Wells and Boreholes (State Coordinating Committee on Ground Water) 2015.

- 1.1 The process of decommissioning a boring or monitoring well includes the following:
 - Verifying that the boring or monitoring well is no longer needed for site assessment or remediation purposes. Generally, soil borings not converted to monitoring wells are decommissioned upon completion of the boring.
 - Permanently sealing the boring or well with a low-permeability material
 - Documenting the decommissioning activities
 - For monitoring wells or borings used to characterize or assess ground water, submitting a completed Ohio Division of Natural Resources (ODNR) Geologic Survey "Well Sealing Report" [Ohio Revised Code 1521.05(c), Form DNR 7810.12]. Refer to FSOP 1.8, ODNR Well Construction Log and Well Sealing Report Filing Requirements
- 1.2 Soil borings greater than six feet deep or that intersect the water table must be sealed with a low permeability sealing material upon completion. Bentonite granules or chips are typically used as a sealing material. Under some circumstances (*e.g.*, a boring that intersects multiple saturated zones), the boring may need to be sealed using positive displacement grouting, *i.e.*, installing bentonite grout slurry using a tremie pipe.
- 1.3 Soil borings 6 feet deep or less and that do not intersect the water table may be backfilled with the soil cuttings, topsoil, or other clean fill materials (*e.g.*, sand or gravel) rather than bentonite provided that:
 - The DERR Site Coordinator or other Ohio EPA division representative approves of using a clean soil or fill material.
 - The soil boring does not encounter any hazardous waste, solid waste, or construction and demolition debris (C&DD) materials.
 - The soil cuttings or other materials used for backfill are not known to contain contaminants exceeding any federal or state regulatory concentration levels.
 - The soil cuttings or other materials used for backfill do not contain any solid waste or C&DD.

- 1.4 Monitoring wells must be sealed when no longer needed and may be decommissioned by:
 - 1.5.1 Physically removing the well materials (casing and screen) and sealing the boring with a low-permeability material using positive displacement grouting (*i.e.*, installing bentonite grout slurry, typically using a tremie pipe)
 - 1.5.2 Decommissioning the monitoring well in-place by filling the screen and well casing with bentonite or filling the monitoring well with clean sand to approximately two feet above the top of the screen and filling the well casing with bentonite, removing the protective casing, removing the upper 1 to 3 feet of well casing if possible and filling the upper 1 to 3 feet of the borehole with soil or other clean fill materials
- 1.6 Under some circumstances, DERR's LOE contractor may be needed to decommission borings or monitoring wells. Such situations may include, but are not necessarily limited to, borings or monitoring wells that are greater than 2 inches in diameter, are installed in bedrock, or are installed within the paved area of a highway. These situations may require the use of drilling rigs and other equipment not available to Ohio EPA staff. Decommissioning procedures to be followed by the LOE contractor will vary with site conditions and will be approved through a site-specific work plan (SSWP).
- 1.7 Monitoring wells that are installed below the base of the uppermost saturated zone (*see Section 2.0, Definitions*) and intersect multiple saturated zones generally should be decommissioned by removing the screen and casing, which will require services of DERR's LOE contractor. Removing the screen and casing may not be possible due to the well location and work/equipment obstructions. Under such circumstances, abandoning the well in place may be acceptable.

2.0 Definitions

- 2.1 Bentonite Chips (or Coarse Grade Bentonite): crushed sodium bentonite shale particles sized from $\frac{3}{8}$ - to $\frac{3}{4}$ -inch diameter that are intended to fall through a water column in a boring or well without bridging (also referred to as crushed or chip bentonite)
- 2.2 Bridging: the creation of a void within a decommissioned boring or monitoring well when bentonite chips, pellets or granules are either poured into the boring or well too quickly or prematurely hydrate and fail to form a continuous seal
- 2.3 Granular Bentonite: processed sodium bentonite with a particle size range of 2.4 to 0.8 mm (#8 to #20 mesh), typically used for bentonite grout slurries, but may also be used in dry form to seal borings under certain circumstances
- 2.4 Neat Cement: a mixture of Portland cement and fresh water (5 to 6 gallons of water per 94-pound sack of cement)

- 2.5 Tremie Grouting: pumping a grout slurry through a conductor pipe or tube that extends nearly to the bottom of a boring or monitoring well to positively displace (lift) ground water out of the boring or well as the denser grout is emplaced; this method prevents dilution of the grout, which could inhibit formation of a proper grout seal
- 2.6 Uppermost Saturated Zone: the first (shallowest) zone of saturation present at a given location. The uppermost saturated zone extends from the first ground water encountered to the base of the unit where saturated conditions are not present. For example, the uppermost saturated zone would be from 10 to 20 feet below ground surface (bgs) for a surficial 20-foot thick sand layer saturated from 10 to 20 feet bgs and underlain by low-permeability clay. A monitoring well installed anywhere within 10 to 20-foot bgs would be considered an uppermost saturated zone well. A well installed deeper than that, *i.e.*, below the confining clay layer in lower (second) saturated sand would not be considered an uppermost saturated zone well. Uppermost saturated zones may include perched ground water zones.

3.0 Health and Safety Considerations

- 3.1 Wear appropriate personal protective equipment (PPE) when working near a drilling rig or grout pump. At a minimum, PPE should include protective eyewear, footwear, and hearing protection.
- 3.2 Use hand protection to help prevent injuries when performing boring or monitoring well decommissioning activities that require the use of mechanical or manual equipment.
- 3.3 To avoid direct contact with chemical contaminants and prevent skin irritation, wear chemical-resistant or other protective gloves when handling grouting materials or soil from decommissioning activities. Wash your hands after completing boring or well decommissioning activities.
- 3.4 Well sealing materials, including but not limited to bentonite, cement and sand may present a silica dust hazard. Appropriate health and safety precautions should be implemented to prevent exposure to respirable silica, *e.g.*, engineering controls and/or respirators with the appropriate filter cartridges.

4.0 Procedure Cautions

- 4.1 When decommissioning a boring or monitoring well by pouring bentonite granules or chips into it, use a weighted tape or drilling rods to ensure that the bentonite does not bridge above the bottom of the boring.
- 4.2 Bring the bentonite to within approximately 1 to 3 feet of the ground surface and fill the remainder of the boring with appropriate clean fill materials (*e.g.*, topsoil in a residential lawn area, sand or gravel and asphalt mix in a paved area). If bentonite is brought nearer to the ground surface, it may expand out of the boring

onto the ground. Decommissioned borings containing bentonite that has expanded to the ground surface are aesthetically unattractive and present a slip/fall hazard.

- 4.3** Ground water exhibiting elevated hardness (> 500 ppm) or chloride concentrations (> 1,500 ppm) can suppress the hydration of bentonite grouts. Ground water near solid waste landfill leachate plumes or salt piles may contain high concentrations of chlorides. Under such circumstances use of neat cement grout slurry or an alternative grouting material may be required.

5.0 Personnel Qualifications

Ohio EPA personnel working at sites that fall under the scope of OSHA's hazardous waste operations and emergency response standard (29 CFR 1910.120) must meet the training requirements described in that standard.

6.0 Equipment and Supplies

- 6.1** Bentonite chips or granules
- 6.2** Topsoil, concrete mix, asphalt mix, sand and/or gravel
- 6.3** Potable water
- 6.4** Water level indicator
- 6.5** Weighted measuring tape or drilling rods
- 6.6** Shovel
- 6.7** Pry bar
- 6.8** Sledgehammer
- 6.9** PVC pipe cutter
- 6.10** Photoionization detector (PID)
- 6.11** PPE
- 6.12** Large heavy-duty trashbags
- 6.13** Decontamination equipment and supplies
- 6.14** Field book or decommissioning log form
- 6.15** Camera

7.0 Procedures

7.1 Decommissioning soil borings 6 feet deep or less that do not intersect the water table:

- 7.1.1** If the soil boring does not encounter any hazardous waste, solid wastes, or C&DD materials, then decommission the boring by backfilling it with soil cuttings, topsoil, or other clean fill materials (e.g., sand or gravel). The soil cuttings or other materials used for backfilling must be known to not contain contaminants exceeding any federal or state regulatory concentration levels or any hazardous waste, solid waste or C&DD materials. If the soil boring is located within a paved area, complete the decommissioning in a manner that prevents pavement settling and fill the upper 4 to 6 inches (or pavement thickness) of boring space with concrete or asphalt mix, whichever is appropriate.

- 7.1.2 If the soil boring encounters hazardous waste, solid waste, or C&DD materials, then decommission the boring by backfilling it with bentonite chips or granules unless otherwise directed by the SSWP, DERR Site Coordinator or Ohio EPA client division. Use potable water to hydrate the granules or chips after installation.

7.2 Decommissioning soil borings deeper than 6 feet but less than the depth to the base of the uppermost saturated zone or any boring that intersects the water table:

- 7.2.1 Depending on the subsurface conditions encountered, decommission soil borings by backfilling with bentonite chips or granules.
- 7.2.2 Use a weighted tape or drilling rods to ensure that the bentonite does not bridge in the boring and form a void. The dry bentonite should be hydrated by adding potable water as needed.

7.3 Decommissioning monitoring wells installed in the uppermost saturated zone (in-place decommissioning technique)

- 7.3.1 Before decommissioning the monitoring well, record final static water level and total depth measurements.
- 7.3.2 Fill the monitoring well screen and casing with granular bentonite or chips. Use a weighted tape or drilling rods to ensure that the bentonite does not bridge in the boring and form a void. Clean sand may be substituted for bentonite from the bottom of the well to approximately two feet above the top of the screen.
- 7.3.3 The dry bentonite should be hydrated in lifts by adding potable water as needed.
- 7.3.4 Remove the protective surface casing and concrete seal and cut the well casing between one and three feet below the ground surface.
- 7.3.5 Fill the remaining void with topsoil or other clean fill materials appropriate for the use of the area in which the boring is located. For example, if the boring is in a lawn area, topsoil may be used. If the boring is in a paved area, use sand or gravel topped with a 4- to 6-inch thick layer of asphalt mix or concrete.

7.4 Decommissioning monitoring wells installed below the base of the uppermost saturated zone

- 7.4.1 Monitoring wells installed below the base of the uppermost saturated zone generally should not be decommissioned in place, *i.e.*, the casing and screen generally should be removed. However, removing the screen and casing may sometimes not be possible due to the well location and work/equipment obstructions. Under such circumstances, abandoning the well in place may be acceptable.

- 7.4.2 DERR's LOE contractor should be mobilized to decommission monitoring wells installed below the base of the uppermost saturated zone if the casing and screen are to be removed.

8.0 Data and Records Management

8.1 Document soil boring and well decommissioning procedures, materials and observations on a field decommissioning log form or project field book. Refer to FSOP 1.3, Field Documentation.

8.2 For all wells and soil borings used to assess ground water quality or quantity, an ODNR water well sealing report must be filed. Refer to FSOP 1.8, ODNR Well Construction Log and Well Sealing Report Filing Requirements.

9.0 Quality Assurance and Quality Control

Not applicable

10.0 Attachments

Not applicable

11.0 References

FSOP 1.1, Initial Site Entry

FSOP 1.3, Field Documentation

FSOP 1.8, ODNR Well Construction Log and Well Sealing Report Filing Requirements

Ohio EPA Technical Guidance Manual for Hydrogeologic Investigations and Ground Water Monitoring (February 2009): Chapter 9, Sealing Abandoned Monitoring Wells and Boreholes

Ohio Administrative Code (OAC) 3701-28-07, 3745-9-03 and 3745-9-10 Ohio Revised Code (ORC) 1521.05(c)

State of Ohio, Regulations and Technical Guidance for Sealing Unused Water Wells and Boreholes (State Coordinating Committee on Ground Water) 2015.

Discrete Soil Sampling

FSOP 2.1.1 (May 26, 2020)

Ohio EPA Division of Environmental Response and Revitalization

1.0 Scope and Applicability

- 1.1** While there are multiple mechanical drilling methods (*e.g.*, direct-push, hollow stem auger, rotosonic) for sample collection, unless otherwise approved by Division of Environmental Response and Revitalization (DERR) management, the direct-push method will be used on DERR projects.
- 1.2** Discrete soil sampling is the process of collecting a single soil sample from a specific location and depth interval. Discrete soil sample locations and depths are typically selected based on existing knowledge about site conditions, including:
- Site history and land use
 - Type of contaminant and the nature of release
 - Visual evidence of releases or source areas, *e.g.*, staining, stressed vegetation, leachate seeps
 - Site soil types, geology and hydrogeology
 - Field survey data, *e.g.*, geophysical surveys
 - Field screening results, *e.g.*, PID or mobile laboratory data
 - Analytical results from previous investigations
- 1.3** The number of discrete soil sample locations needed to characterize site conditions is primarily based on professional judgment, which incorporates knowledge of site information, project goals and data quality objectives (DQOs). Discrete sampling is often used to evaluate the spatial distribution of contaminants or other constituent concentrations within a soil unit (see ITRC reference below). Examples include but not limited to:
- Sampling to define the extent of soil contamination from a surface spill
 - Sampling to identify and define the extent of soil contamination associated with a leaking Underground Storage Tank (UST) system
 - Sampling to verify that the extent of a contaminated soil excavation meets remedial objectives
 - Sampling to determine background concentrations or provide concentration data for geochemical modeling or risk assessment based on statistical evaluation, *e.g.*, calculation of a 95% upper confidence limit on the mean
- 1.4** The relatively small size of a single discrete sample is generally inadequate to definitively characterize the large volume of un-sampled soil surrounding it, and analytical results should not be extrapolated beyond the immediate vicinity of the sampling location (see ITRC reference below). Discrete sampling may not be preferred when:

- Sampling to determine the average concentrations of constituents in soil underlying a specified area
- Sampling to determine background concentrations or provide concentration data for geochemical modeling or risk assessment based on statistical evaluation when statistical data analysis is not required

For these situations either composite or incremental sampling may be appropriate.

2.0 Definitions

Not applicable

3.0 Health and Safety Considerations

- 3.1 Please refer to FSOP 1.2, Utility Clearance. Underground utility clearance must be requested prior to conducting hand or mechanical excavation of soil or sediment per Ohio Revised Code (ORC) 3781.25(I).
- 3.2 Wear appropriate personal protective equipment (PPE) when working in the vicinity of drilling or other types of mechanical soil sampling equipment. At a minimum, PPE should include sample gloves, protective eyewear, and protective footwear (OSHA 1910.136). Hearing protection is required in noisy environments. A hard hat (ANSI 289.1-2003 Type II Class E, protection from top and side impact) is required if overhead hazards are present or if required by the facility where work is being performed. Canvas coveralls (or similar protective clothing) are also recommended.
- 3.3 Use heavy protective gloves to help prevent hand injuries when using hand augers or other manual sampling equipment or handling and opening core barrels, split spoons or core liners.
- 3.4 Wear chemical-resistant gloves when handling soil samples to avoid direct contact with chemical contaminants. Always thoroughly wash your hands after completing soil sampling activities.
- 3.5 If free product or splash hazards are a concern during drilling and sampling, use of a chemically resistant suit (e.g., Saranex or coated Tyvek) is recommended.
- 3.6 If dusty conditions are present, respiratory protection may be necessary to provide protection from dust-inhalation hazards. Work must be stopped to assess site conditions. Work requiring respiratory protection may only be performed by staff certified to wear respiratory protection. Depending on site-specific conditions and chemicals of concern, monitoring with a particulate meter or other air monitoring instruments may be appropriate. To review action levels, refer to the NIOSH Pocket Guide to Chemical Hazards.

- 3.7 Conduct air monitoring in accordance with the site-specific health and safety plan. For action levels, refer to Table 1 of FSOP 1.1, Initial Site Entry.
- 3.8 Dress appropriately for anticipated weather conditions, and always have ample drinking water available when working in hot weather. Insect repellent may be needed for protection from ticks, mosquitoes, and other biting insects in heavily wooded areas.

4.0 Procedure Cautions

- 4.1 Review the site-specific work plan (SSWP) before performing field work to ensure that the discrete sampling method is appropriate for project objectives and the associated DQOs.
- 4.2 Evaluate access to all borings/soil sampling locations before mobilization of drilling or other sampling equipment to the site
- 4.3 Hand augers (bucket augers) or triers (probes) may be difficult to advance in dense clayey soils or gravelly soils.
- 4.4 Loose sandy soils may fall out of hand augers or triers as these samplers are extracted from the subsurface.
- 4.5 Triers are limited to a relatively small sample volume (e.g., a 5/8-inch by 12-inch soil core) that may not be adequate for analysis of multiple constituents (e.g., semi-volatile organics (SVOCs), pesticide, polychlorinated biphenyls (PCBs), and metals) without collecting multiple co-located samples.
- 4.6 Complete all activities associated with soil sampling (e.g., soil boring logging or field screening). These activities will be described in the SSWP.
- 4.7 Use insect repellents and other chemicals in a manner that minimizes the potential for soil sample cross contamination, e.g., apply insect repellent in the morning before drilling and sampling activities begin.
- 4.8 Avoid excessive handling or manipulation of soil samples collected for laboratory analysis. Portions of a soil sample used for logging or screening purposes should not be used for laboratory analysis. Soil samples collected for laboratory analysis should be placed in laboratory containers and appropriately preserved as soon as possible.
- 4.9 Soil samples collected for VOC analysis require special sampling and handling techniques. Refer to FSOP 2.1.6, Soil Sample Collection for Volatile Organic Compound Analysis by Bulk Sampling Methods, or FSOP 2.1.7, Soil Sample Collection for Volatile Organic Compound Analysis Compliant with U.S. EPA SW 846 Methods 5035 and 5035A.

5.0 Personnel Qualifications

Ohio EPA personnel working at sites that fall under the scope of OSHA's hazardous waste operations and emergency response standard (29 CFR 1910.120) must meet the training requirements described in that standard.

6.0 Equipment and Supplies

- 6.1 Soil sampling equipment, including but not limited to spoons, trowels, triers (probes), hand augers (bucket augers), shovels and/or drilling equipment
- 6.2 Soil screening equipment (e.g., PID) and supplies, as needed
- 6.3 PPE
- 6.4 Stainless steel pans, disposable aluminum pans, stainless steel spoons and/or stainless-steel spatulas for splitting, homogenizing, or otherwise manipulating soil samples
- 6.5 Plastic sheeting
- 6.6 Tools for clearing vegetation and surface debris from soil sampling locations (e.g., shovels, brush axes, etc.)
- 6.7 Laboratory containers and labels
- 6.8 Sample cooler(s) with ice (if needed)
- 6.9 Field documentation supplies and equipment, including pens, markers, field log/data sheets, field logbook, chain-of-custody forms, camera
- 6.10 Decontamination equipment and supplies
- 6.11 SSWP and HASP

7.0 Procedures

- 7.1 Before performing soil sampling activities, review the SSWP. The SSWP will provide locations and approximate depths for discrete soil samples, information regarding anticipated subsurface conditions at the site (e.g., soil types, nature of contamination, depth to ground water, etc.), and any required field screening or soil logging activities.
- 7.2 Refer to FSOP 1.4, Sample Identification Nomenclature, for sample labeling and identification.
- 7.3 Discrete Soil Sample Collection Using Manual Equipment
 - 7.3.1 Use manual sampling equipment capable of extracting soil samples that will meet both project goals and DQOs.
 - 7.3.2 Place sampling equipment and supplies on a clean plastic sheet adjacent to each sampling location to prevent cross-contamination by direct contact with the ground surface.
 - 7.3.3 Remove surface debris such as vegetation, gravel or other materials or debris prior to sampling.

- 7.3.4 Wear a new pair of clean sampling gloves when collecting each discrete soil sample.
- 7.3.5 If required, perform soil field screening or logging activities using a representative portion of the soil sample that is not needed for laboratory analysis. Screening and logging may be performed on a separate split or subsample before or after laboratory containers have been filled. Refer to FSOP 2.1.4, Sample Headspace Screening, and FSOP 2.1.5, Soil Description, Classification and Logging.
- 7.3.6 Soil samples for VOC analysis should be collected first in accordance with the following FSOPs, depending on project objectives and DQOs identified in the SSWP:
- FSOP 2.1.6, Soil Sample Collection for Volatile Organic Compound Analysis by Bulk Sampling Methods
 - FSOP 2.1.7, Soil Sample Collection for Volatile Organic Compound Analysis Compliant with U.S. EPA SW 846 Methods 5035 and 5035A
- 7.3.7 For non-VOC soil samples, use a disposable aluminum pan or a stainless-steel pan or bowl to contain and homogenize the soil sample prior to filling laboratory container (if applicable).
- 7.3.8 For non-VOC constituents, fill the laboratory containers with a representative portion of the soil increment sampled in the order of decreasing sensitivity to volatilization (e.g., SVOCs, pesticides, PCBs, metals).
- 7.3.9 If required for analytical sample preservation, immediately place the labeled and filled laboratory containers in a cooler on ice.
- 7.3.10 Complete the chain-of-custody form and applicable boring logs, field forms, logbook or log sheets in accordance with FSOP 1.3, Field Documentation.
- 7.3.11 Decontaminate non-disposable sampling equipment between sampling locations unless the SSWP requires more frequent decontamination (e.g., between depth intervals at each location). Refer to FSOP 1.6, Sampling Equipment Decontamination.

7.4 Soil Sample Collection Using Direct-Push Drilling Equipment

- 7.4.1 Two types of direct push samplers are typically used for the collection of discrete soil samples:
- The Macro-Core™ Soil Sampling System is used to collect continuous soil cores from an uncased boring (the sampler and rods are removed from the boring after each soil sample is collected and then reinserted to collect the next sample).

- The Dual Tube Soil Sampling System is used to collect continuous as well as discrete depth soil cores from within a sealed casing (the boring remains open while soil samples are collected and extracted). Soil cores are approximately one inch in diameter by 48 inches long.

Disposable acetate core liners are used with both sampler types.

The sampler type(s) selected should produce soil samples that meet both project goals and DQOs. For example, if a large volume of soil sample will be needed for multiple constituents (*e.g.*, SVOCs, pesticides/PCBs and metals) the Macro-Core™ sampling system is likely the best choice.

However, if samples need to be collected below a zone of soil contamination, the Dual Tube sampling system will minimize potential cross contamination between contaminated and uncontaminated soils.

- 7.4.2 Wear a new pair of clean chemical resistant sampling gloves when collecting each discrete soil sample.
- 7.4.3 If any of the soil in the sampler appears to be caved or sloughed material from the open boring overlying the sampled interval, remove it from the sampler. Do not submit it for laboratory analysis or log it as part of the sampled interval. If in doubt based on sample appearance, consult with the driller regarding the stability of the borehole (*i.e.*, is it collapsing or heaving between sample intervals?) Treat this material as investigation-derived waste per FSOP 1.7, Investigation Derived Waste.
- 7.4.4 Record the depth interval and recovery of each soil sample to the nearest one-tenth (0.1) foot. Do not record a recovery that is greater than the length of the soil core. For example, if a core sampler pushed from 8.0 to 10.0 feet recovers only 1.5 ft of soil core, record the recovery as 1.5 ft (or 8.0 to 9.5 ft), not 2.0 ft (or 8.0-10.0 ft).
- 7.4.5 If required, perform soil field screening or logging activities (*e.g.*, PID screening, soil type identification and description) using a representative portion of the soil sample that is not needed for fixed-base laboratory analysis. Screening and logging activities may be performed before or after laboratory containers have been filled. Refer to FSOP 2.1.4, Sample Headspace Screening, and FSOP 2.1.5, Soil Description, Classification and Logging.
- 7.4.6 Soil samples for VOC analysis should be collected first in accordance with the following FSOPs depending on project objectives and DQOs identified in the SSWP:
 - FSOP 2.1.6, Soil Sample Collection for Volatile Organic Compound Analysis by Bulk Sampling Methods
 - FSOP 2.1.7, Soil Sample Collection for Volatile Organic Compound Analysis Compliant with U.S. EPA SW 846 Methods 5035 and 5035A

- 7.4.7 For non-VOC constituents, fill the laboratory containers with a representative portion of the soil increment sampled in the order of decreasing sensitivity to volatilization (e.g., SVOCs, pesticides/PCBs, metals).
- 7.4.8 If required for analytical sample preservation, immediately place the labeled and filled laboratory containers in a cooler on ice.
- 7.4.9 Complete the chain-of-custody form and applicable boring logs, field forms, logbook or log sheets in accordance with FSOP 1.3, Field Documentation.
- 7.4.10 Direct-push (e.g., Geoprobe™) sampling equipment does not need to be decontaminated between sampling locations because soil cores are collected in disposable acetate liners. However, if gross contamination (e.g., non-aqueous phase liquids) is encountered or if the potential for cross-contamination is a concern, the direct-push Geoprobe™ sampling equipment should be decontaminated in accordance with FSOP 1.6, Sampling Equipment Decontamination.
- 7.5 Prepare samples for delivery to the laboratory in accordance with FSOP 1.5, Sample Custody and Handling.
- 7.6 Dispose of unused soil samples, disposable sampling equipment and used supplies in accordance with FSOP 1.7, Investigation Derived Waste.
- 7.7 After sampling activities are completed, decommission the boring or shallow excavation in accordance with FSOP 1.9, Boring and Monitoring Well Decommissioning
- 7.8 After sampling activities are completed, file ODNR well logs as necessary in accordance with the requirements of FSOP 1.8, ODNR Well Construction Logs & Well Sealing Reports.

8.0 Data and Records Management

Refer to FSOP 1.3, Field Documentation

9.0 Quality Assurance and Quality Control

Quality assurance/quality control (QA/QC) samples may include equipment blanks, field blanks and/or trip blanks depending on the site-specific chemicals of concern and conditions. Duplicate soil samples are to be collected at a minimum of 1 per 10 soil samples collected. Duplicate samples are required for U.S. EPA Contract Laboratory Program sampling events conducted at Federal CERCLA sites. Duplicate soil samples should not be collected at sites under other regulatory programs unless otherwise directed by DERR management.

10.0 Attachments

None

11.0 References

FSOP 1.1, Initial Site Entry

FSOP 1.2, Utility Clearance

FSOP 1.3, Field Documentation

FSOP 1.4, Sample Identification Nomenclature

FSOP 1.5, Sample Custody and Handling

FSOP 1.6, Sampling Equipment Decontamination

FSOP 1.7, Investigation Derived Waste

FSOP 1.8, ODNR Well Construction Logs & Well Sealing Reports

FSOP 1.9, Boring and Monitoring Well Decommissioning

FSOP 2.1.4, Sample Headspace Screening

FSOP 2.1.5, Soil Description, Classification and Logging

FSOP 2.1.6, Soil Sample Collection for Volatile Organic Compound Analysis by Bulk Sampling Methods

FSOP 2.1.7, Soil Sample Collection for Volatile Organic Compound Analysis Compliant with U.S. EPA SW 846 Methods 5035 and 5035A

ITRC (Interstate Technology & Regulatory Council), 2012, Incremental Sampling Methodology (ISM-1): Interstate Technology & Regulatory Council, Incremental Sampling Methodology Team, Washington, D.C., www.itrcweb.org. [Note: ISM-2 is scheduled for release in Fall 2020.]

Ohio Revised Code 3781.25(I)

OSHA 1910.136, Personal Protective Equipment (Foot Protection)

Soil Description, Classification and Logging

FSOP 2.1.5 (June 30, 2020)

Ohio EPA Division of Environmental Response and Revitalization

1.0 Scope and Applicability

- 1.1 This procedure describes standard practices and recommendations used by the Division of Environmental Response and Revitalization (DERR) for field soil description, classification and logging.
- 1.2 This FSOP is not intended to replace the education or experience of Ohio EPA staff members who have degrees in geology, hydrogeology, soil science, geotechnical engineering, or similar fields. This FSOP should be used in conjunction with professional judgment.
- 1.3 For the purposes of this FSOP, “soil” includes natural deposits or natural fill materials consisting primarily of granular or cohesive mineral particles derived from sedimentary deposition or the weathering of bedrock. In addition, soil may contain minor amounts of natural organic debris or minor amounts of inorganic or organic waste materials. Soil may be unconsolidated or consolidated but is never cemented or lithified.
- 1.4 As discussed in this FSOP, soil description is a method of documenting the observed physical properties of soil for scientific or engineering purposes. Soil properties that are important for evaluating the behavior and fate of contaminants at waste sites include, but are not necessarily limited to the following:
 - texture (also referred to as grain-size or particle size distribution)
 - plasticity characteristics
 - color
 - moisture content
 - sedimentary structures
 - anthropogenic influence: the presence of fill materials, waste materials, hazardous substances, or petroleum

The soil properties and soil property criteria described in the FSOP are based on ASTM D2488-09a, Standard Practice for Description and Identification of Soils (Visual-Manual Procedure). ASTM D2488 is also recommended by the Ohio EPA Division of Drinking and Ground Water (DDAGW) Technical Guidance Manual for Ground Water Investigations (TGM), Chapter 3, Characterization of Site Hydrogeology, for soil description and classification for hydrogeologic investigations.

- 1.5 Soil classification is a method of systematically categorizing soil into groups with similar physical properties based on field description or laboratory testing. For environmental site assessment and engineering purposes, a soil classification system provides a uniform description of the physical properties of soil. U.S. EPA

(April 1999) recommends the use of the following soil classification systems for environmental investigations at hazardous waste sites:

- 1.5.1 The Unified Soil Classification System (USCS) as described by ASTM D2488-09a, Standard Practice for Description and Identification of Soils (Visual-Manual Procedure)
- 1.5.2 The United States Department of Agriculture (USDA) Soil Textural Triangle, USDA Natural Resources Conservation Service Soil Survey Manual, Chapter 3, Examination and Description of Soils (Figure 3-16)

Project data quality objectives (DQOs) should determine whether the USCS or USDA systems (or both) are used.

- 1.6 Soil description and classification should be performed: 1) during the collection of soil samples for laboratory analysis; 2) during the installation of borings, monitoring wells or soil gas/vapor probes; or 3) whenever characterization of subsurface geologic conditions is needed to meet site assessment project or data quality objectives.

Describing and classifying soil samples in an accurate and consistent manner:

- is critical for understanding site geology and hydrogeology
 - helps to ensure proper location and construction of monitoring wells and soil gas probes
 - facilitates the selection of samples for laboratory analysis and the subsequent evaluation of contaminant distribution and migration
 - may provide an understanding of contaminant migration pathways
 - determines the thickness of cover materials or depth of wastes or contaminated soil layers
 - provides a means of correlating soil types with geophysical surveys
- 1.7 Logging the description and classification of soil samples includes the continuous recording of drilling and sampling, field monitoring, and well or probe construction data. A field logging form (example attached) is recommended for logging soils collected with direct-push or rotary drilling rigs or excavating equipment. The form may also be designed to record ground water data and serve as a monitoring well or soil gas probe construction diagram.

2.0 Definitions

Refer to the attached list (Soil Descriptive Terminology).

3.0 Health and Safety Considerations

- 3.1 Wear appropriate personal protective equipment (PPE) when working in the vicinity of drilling rigs or other types of mechanical equipment used for soil sampling, in accordance with the site-specific health and safety plan. At a minimum, PPE should include protective eyewear, footwear, and hearing protection. In addition, a hard hat is required when working in the vicinity of drilling rigs and the use of canvas coveralls or similar protective clothing is recommended.
- 3.2 Use heavy protective gloves to help prevent hand injuries when opening and handling split-spoon samplers, core barrels, or plastic soil core liners.
- 3.3 Wear chemical-resistant gloves when handling soil samples to avoid direct contact with chemical contaminants. Always thoroughly wash your hands after completing soil logging activities.
- 3.4 If free product or splash hazards are a concern during drilling or sampling, use of a chemically resistant suit (e.g., Saranex[®] or coated Tyvek[®]) is recommended.
- 3.5 If drilling and soil sampling activities cause dusty conditions, respiratory protection may be necessary to provide protection from dust-inhalation hazards. Work should be stopped to assess site conditions. Work requiring respiratory protection may only be performed by staff certified to wear respiratory protection. Depending on site-specific conditions and chemicals of concern, monitoring with a particulate meter and/or other air monitoring instruments as appropriate. For action levels, refer to Table 1 of FSOP 1.1, Initial Site Entry.
- 3.6 Conduct air monitoring in accordance with the site-specific health and safety plan. For action levels, refer to Table 1 of FSOP 1.1, Initial Site Entry.
- 3.7 Dress appropriately for anticipated weather conditions, and always have ample drinking water available when working in hot weather. Insect repellent may be needed for protection from ticks, mosquitoes, and other biting insects in heavily wooded areas.

4.0 Procedure Cautions

- 4.1 For logging soil borings or excavations greater than six feet deep, a field logging form (example attached) is preferred. Logging soil borings using a field logbook or log sheets may be difficult due to the volume of information that typically needs to be recorded.
- 4.2 Use a level of detail for soil descriptions that is consistent with the site-specific work plan and project DQOs.

- 4.3 If the driller is collecting soil samples so quickly that logging is difficult, direct the driller to slow down or stop. Soil cores should be processed (*i.e.*, logged, screened, and sampled) as soon as possible after being retrieved from the ground.
- 4.4 When recording soil descriptions, use a consistent format such as that recommended in paragraph 7.9. Doing so makes logging easier, improves the readability of the field log, and facilitates subsequent data entry in the office.
- 4.5 Do not indiscriminately apply soil classification systems. Project DQOs will determine whether the USCS, USDA classification system, or both systems should be used for a project. Additionally, DQOs may indicate how soil classification should be applied at a site with respect to boring locations and depth of investigation.
- 4.6 An accurate location of each boring should be included on the logging form (or field notebook). The location could include a narrative description of the boring location with reference to site features, a schematic and/or GPS coordinates.

5.0 Personnel Qualifications

Ohio EPA personnel working at sites that fall under the scope of OSHA's hazardous waste operations and emergency response standard (29 CFR 1910.120) must meet the training requirements described in that standard. In addition, personnel who log soil borings should have a background in geology, hydrogeology, soil science or geotechnical engineering, or should have received training in soil classification, description and logging from a qualified individual.

6.0 Equipment and Supplies

- 6.1 Field logging form (example attached)
- 6.2 Field logbook or log sheets (*recommended for use as an alternative to a logging form only if soil logging activities are limited to borings or excavations less than six feet deep*).
- 6.3 Engineering ruler or measuring tape with 0.1 foot increments for measuring soil cores
- 6.4 Stainless steel spatula or knife for examining and sampling soil core
- 6.5 Field guide for soil classification/description or soil texturing, a geotechnical (sand) gauge, and/or Munsell Soil Color chart (optional)
- 6.6 Hand lens (optional, helps identify waste materials)
- 6.7 Magnet (optional, helps identify waste materials)

7.0 Procedures

- 7.1 Before drilling begins record project information, boring identification and location, the date, and drilling and sampling method(s) on the soil logging field form.
- 7.2 Be sure that the driller identifies the top of each core sample.
- 7.3 If any of the soil in the sampler appears to be caved or sloughed material from the open boring overlying the sampled interval, remove it from the sampler. Do not log it as part of the sampled interval or submit it for laboratory analysis. If in doubt based on sample appearance, consult with the driller regarding the stability of the borehole, i.e., is it collapsing or heaving between sample intervals?
- 7.4 Using the ruler or tape, measure the length of the soil core recovered from each sampled interval (excluding any caved/sloughed material if present). Record the sampler type and the sampled interval recovery to the nearest 0.1 foot on the soil logging field form. Do not record a recovery that is greater than the length of soil core actually recovered. For example, if a core sampler pushed from 8.0 to 10.0 ft recovers only 1.5 ft of soil core, record the recovery as 1.5 ft (or 8.0 to 9.5 ft) and not 2.0 ft (or 8.0-10.0 ft).
- 7.5 Discuss possible reasons for core loss with the driller, as well as the driller's insight on likely soil or fill materials encountered based on the behavior of the drilling and sampling equipment.
- 7.6 Split or scrape any soil core consisting of cohesive soils (silts or clays) using a stainless steel knife or spatula.
- 7.7 Quickly examine the soil core and evaluate the following properties (preliminary evaluation) to select samples for field screening and/or analytical sampling:
 - Soil texture (*i.e.*, is it mostly gravel, sand, silt, or clay?) and changes in texture within the core sample
 - Moisture content
 - The presence of waste materials, potentially hazardous substances, or petroleum (*the hand lens and/or magnet may be helpful*)
- 7.8 As required, collect soil samples for field screening and laboratory analysis based on project DQOs and preliminary core examination (paragraph 7.5). Assign each screening or laboratory sample an identification number). Record the sample identification and depth interval to the nearest 0.1 foot on the soil logging form.
- 7.9 Record a description of the soil core. The soil properties included in the description will depend on project DQOs; however, a soil description should generally include the following information:

- 7.9.1 **Soil color:** the following colors (with Munsell Soil Color Chart numbers for reference only) are recommended for soil description:

Brown Shades	Munsell #	Gray Shades	Munsell #
Brownish yellow	10YR 6/6	Grayish brown	2.5Y 5/2
Light brown	10YR 7/4	Light gray	2.5Y 7/1
Reddish brown	5YR 5/4	Gray	2.5Y 5/1
Brown	10YR 4/3	Greenish gray	GLE Y1 5/1
Dark yellowish brown	10YR 4/6	Olive gray	5Y 4/2
Dark brown	10YR 3/3	Dark gray	2.5Y 4/1

If the soil exhibits a primary color and one or more secondary colors, describe the soil color as “mottled” or “with mottling”, e.g., “gray with brownish yellow mottling” or “mottled light brown, dark yellowish brown, and light gray”.

- 7.9.2 **Soil classification:** follow the attached Unified Soil Classification System Field Guidance to classify soils according to the USCS or the attached Estimating Soil Texture By Feel (Presley and Thien, September 2008) to classify soils according to the USDA System.

- 7.9.3 **Moisture content:** ASTM D2488-09a recommends describing soil moisture content as follows:

- **Dry** – absence of moisture, dry and dusty to the touch
- **Moist** – damp but no visible water
- **Wet** – visible free water, usually soil is below the water table

The terms “**slightly moist**” (intermediate between dry and moist) and “**very moist**” (intermediate between moist and wet) may also be used.

- 7.9.4 **Plasticity characteristics** (for silts and clays only): describe the soil **plasticity**. If possible, also include descriptions for **consistency**, **dilatancy**, and/or **toughness** (refer to Soil Descriptive Terminology, attached). The dry strength test is generally too time-consuming to be performed.

- 7.9.5 **Sedimentary structures:** describe soil sedimentary structures (refer to Soil Descriptive Terminology)

- 7.9.6 **Anthropogenic influence:** determine if the soil is native or fill material, and describe the presence of waste materials (construction/demolition debris, solid waste, industrial wastes), hazardous substances, or petroleum (*the hand lens and magnet may be helpful*)

- 7.10 The following soil properties may also be included in soil descriptions at the discretion of the soil logger:
- 7.10.1 Secondary grain size percentages as recommended by ASTM D2488-09a:
 - Trace – particles are present but estimated to be less than 5%
 - Few – 5% to 10%
 - Little – 15% to 25 %
 - Some – 30% to 45%
 - Mostly – 50% to 100%
 - 7.10.2 Depositional environment (*Note: this is a geologic interpretation based on soil texture and sedimentary structures which should be made by a geologist or hydrogeologist.*)
 - 7.10.3 Oxidation, leaching and/or degree of weathering
 - 7.10.4 Other properties described in ASTM D2488-09a
- 7.11 The following soil description format is suggested: *consistency – color – soil classification: moisture content, plasticity characteristics, sedimentary structures, anthropogenic influence, other*
- Examples:
- *firm gray lean clay with dark yellowish brown mottling: moist, medium toughness and plasticity, massive structure, solvent odor*
 - *brownish yellow loam: dry to slightly moist, low plasticity, vertical fractures with iron oxide staining, broken glass and demolition debris (concrete, brick and wood fragments)*
 - *dark brown sand: wet, stratified, trace fine gravel*
 - *soft gray lean clay with silt: moist to very moist, low to medium plasticity, no dilatancy to slow dilatancy, varved, lacustrine (lake) deposit*
- Regardless of the specific soil description format, a consistent format should be utilized for borings on the same site/property or installed for the same project.
- 7.12 In addition to soil descriptions, record field information associated with boring installation, soil sampling or well or probe installation on the soil logging form. Such information may include, but is not limited to the following:
- Field screening data
 - Laboratory sample identification numbers for soil and ground water samples
 - Ground water levels

- Relevant information recorded by the driller, e.g., changes in penetration resistance
 - Monitoring well screen placement and sand pack thickness
 - GPS coordinates and/or other boring location data
- 7.13 Properly dispose of IDW in accordance with FSOP 1.7, Investigation-Derived Wastes.
- 7.14 In addition to completing a field logging form for each soil boring, an Ohio Department of Natural Resources (ODNR) Well Log and Drilling Report Form may need to be filed with the ODNR Division of Soil and Water Resources. Refer to FSOP 1.8, ODNR Well Construction Logs & Well Sealing Reports.

8.0 Data and Records Management

Please refer to FSOP 1.3, Field Documentation.

9.0 Quality Control and Quality Assurance

Draft soil boring logs should be peer-reviewed by an Ohio EPA staff member with a degree in geology, hydrogeology, soil science, geotechnical engineering, or similar field experience before being finalized.

10.0 Attachments

Logging Field Form (example)

Soil Descriptive Terminology

Unified Soil Classification System Field Guidance

Presley, D. and Thien, S., September 2008, Estimating Soil Texture By Feel, Kansas State University

11.0 References

ASTM D 2488-09a, Standard Practice for Description and Identification of Soils (Visual-Manual Procedure)

FSOP 1.1, Initial Site Entry

FSOP 1.3, Field Documentation

FSOP 1.7, Investigation Derived Waste

FSOP 1.8, ODNR Well Construction Logs & Well Sealing Reports

Ohio EPA Division of Drinking and Ground Waters, April 2015, Technical Guidance Manual for Ground Water Investigations: Chapter 3, Characterization of Site Hydrogeology

Munsell Soil Color Chart

USDA Natural Resources Conservation Service, October 1993, Soil Survey Manual: Chapter 3, Examination and Description of Soils

U.S. EPA (D.S. Burden and J.L. Sims), April 1999, Ground Water Issue, Fundamentals of Soil Science as Applicable to the Management of Hazardous Wastes: EPA/540/S-98/500

Soil Descriptive Terminology

Page 1 of 2

Consistency: the relative ease with which a fine-grained soil (silt or clay) can be deformed. ASTM D2488-09a recommends describing consistency as follows:

- **Very soft** – thumb will penetrate soil more than 1 inch
- **Soft** – thumb will penetrate soil about 1 inch
- **Firm** – thumb will indent soil about ¼ inch
- **Hard** – thumb will not indent soil, thumbnail will indent soil
- **Very hard** – thumbnail will not indent soil

Dilatancy: volume increase under loading, or expansion (and flow) of a saturated fine-grained soil (silt or clay) in response to shaking. ASTM D2488-09a recommends describing dilatancy as follows:

- **None** – no visible change
- **Slow** – water appears slowly on the surface of the soil during shaking (and disappears slowly upon squeezing)
- **Rapid** – water appears quickly on the surface of the soil during shaking (and disappears quickly upon squeezing)

Dry Strength: the relative strength of a dried fine-grained soil (silt or clay) specimen approximately 1/2 inch in diameter. ASTM D2488-09a recommends describing dry strength as follows:

- **None** – the specimen crumbles into powder when handled
- **Low** – the specimen crumbles into powder in response to finger pressure
- **Medium** – the specimen crumbles or breaks into pieces with considerable finger pressure
- **High** – the specimen cannot be broken with finger pressure, but can be broken between the thumb and a hard surface
- **Very High** – the specimen can be broken between the thumb and a hard surface

Plasticity: the ability of a fine-grained soil (silt or clay) to deform continuously under constant stress. ASTM D2488-09a recommends describing plasticity as follows:

- **Nonplastic** – a 1/8 inch diameter thread cannot be rolled at any water content
- **Low Plasticity** – the thread can barely be rolled
- **Medium Plasticity** – the thread is easily rolled and not much time is required to reach the plastic limit (i.e., the water content at which a soil changes from a plastic state to a semisolid state)
- **High plasticity** – the thread is easily rolled and considerable time rolling and kneading is required to reach the plastic limit; the thread can be re-rolled several times after reaching the plastic limit

Soil Descriptive Terminology

Page 2 of 2

Sedimentary Structure: a soil structure formed by sedimentary deposition, e.g., glacial, stream, or lake deposition (primary sedimentary structure) or by processes occurring subsequent to deposition and/or soil formation, e.g., weathering or hydrologic processes (secondary sedimentary structure). Terminology used to describe sedimentary structure includes the following:

- **Massive** – stratification (or layering) is not present; the soil appears to have a homogeneous structure which is the same in all directions
- **Stratified** – distinct near-horizontal layers (or beds) formed primarily by differences in texture (grain-size)
- **Graded** – stratified layers exhibiting grain-sizes that gradually increase or decrease with depth (usually referred to as “graded bedding”)
- **Laminated** – horizontal layers less than approximately 0.2 inches thick (laminations)
- **Varved** – alternating light and dark laminations (varves) formed by seasonal sediment deposition in lakes
- **Lensed** – a soil containing small pockets or lenses one or more different soil types, e.g., pockets of sand in a clay
- **Fractured** – vertical or horizontal planes of separation formed by wetting/drying, freezing/thawing, or other physical processes to which the soil is exposed; fractures are generally near-vertical and often contain mineralization distinct from the adjacent soil (iron oxides/hydroxides, carbonates, etc.)
- **Slickensided** – fracture planes that appear polished or glossy and sometimes slightly curved and/or striated; generally slickensides are formed by shearing of the soil in response to loading or deformation (e.g., swelling clays)

Toughness: pressure required to roll a fine-grained soil (silt or clay) into a 1/8 inch thread. ASTM D2488-09a recommends describing toughness as follows:

- **Low** – only slight pressure is needed to roll the thread, which is weak and soft
- **Medium** – medium pressure is needed to roll the thread, which is moderately stiff
- **High** – considerable pressure is needed to roll the thread, which is very stiff

Unified Soil Classification System (USCS) Guide¹

Page 1 of 2 (Silt and Clay)

If the soil consists of $\geq 50\%$ fines (silt and clay), then the soil is a fine-grained soil. Follow these steps for field classification of silt (M) and clay (C):

1. Using manual field tests, classify the soil as a silt (ML), lean clay (CL), elastic silt (MH) or fat clay (CH) based on its plasticity characteristics:

Soil Type	Group Symbol	Dry Strength	Dilatancy	Toughness & Plasticity
Silt	ML	None to low	Slow to rapid	Nonplastic to low
Lean Clay	CL	Medium to high	None to slow	Medium
Elastic Silt	MH	Low to medium	None to slow	Low to medium
Fat Clay	CH	High to very high	None	High

Tips for classifying fine-grained soils:

- Plasticity and dilatancy may be used to differentiate silt (ML) and lean clay (CL) (*dry strength and toughness data usually aren't critical field tests*).
 - Lean clay (CL) is more common than fat clay (CH) in Ohio.
 - Elastic silt (MH) is rarely encountered in Ohio.
 - Use "lean clay" rather than "silty clay" (CL-ML) for USCS field description of soil. Laboratory testing is necessary to classify a soil as a USCS silty clay due to its narrow plasticity index range (4-7).
2. After identifying the soil as a silt or clay, estimate the percentage of sand and gravel (S&G) ("*plus No. 200 material*" or > 0.075 mm diameter particles) in the sample:
 - a. If $< 15\%$ S&G, classify the soil as a **silt (ML)**, **lean clay (CL)**, **elastic silt (MH)**, or **fat clay (CH)**
 - b. If 15% - 25% S&G, add "**with sand**" if the $\%S \geq \%G$ or "**with gravel**" if the $\%G > \%S$, e.g., **lean clay with sand (CL)**, **silt with gravel (ML)**
 - c. If $\geq 30\%$ S&G and the $\%S \geq \%G$, add the modifier "**sandy**", and if $\geq 15\%$ G add "**with gravel**", e.g., **sandy silt (ML)**, **sandy lean clay with gravel (CL)**
 - d. If $\geq 30\%$ S&G and the $\%G > \%S$, add the modifier "**gravelly**", and if $\geq 15\%$ S add "**with sand**", e.g., **gravelly fat clay (CH)**, **gravelly lean clay with sand (CL)**
 3. If the fine-grained soil contains enough organic matter to influence its physical properties, e.g., the soil feels "spongy" during field plasticity testing, classify it as an organic silt or clay (OL or OH). Follow step two (above) to describe the coarse-grained texture characteristics (S&G) of the soil. If the soil is mostly organic matter, classify it as peat (PT).

¹ Based on ASTM D2488-09a, Standard Practice for Description and Identification of Soils (Visual–Manual Procedure)

Unified Soil Classification System (USCS) Guide¹

Page 2 (Sand and Gravel)

If the soil consists of < 50% fines (silt and clay), then the soil is a coarse-grained soil (sand or gravel). Follow these steps for field classification of sand (S) and gravel (G):

1. Estimate the relative percentages of sand and gravel:
 - a. If the % S \geq % G, then the soil is a sand
 - b. If the % G > % S, then the soil is a gravel
2. Estimate the percentage of fines (silt and clay) present in the soil:
 - a. \leq 5%
 - b. Approximately 10%
 - c. \geq 15 %
3. Determine if the fines are mostly clay (plastic) or silt (nonplastic)
4. If the soil contains \leq 5% fines or approximately 10% fines, then determine if the soil is well-graded (W) (*poorly sorted with a wide range of grain sizes*) or poorly graded (P) (*well-sorted with relatively uniform grain size*)
 - a. If the soil contains \leq 5% silt or clay, the soil is **well-graded** or **poorly graded sand** (SW or SP) or **well-graded** or **poorly graded gravel** (GW or GP)
 - b. If the soil contains approximately 10% silt or clay, the soil is **well-graded** or **poorly graded sand with silt** (SW-SM, SP-SM) or **clay** (SW-SC, SP-SC) or **well-graded** or **poorly graded gravel with silt** (GW-GM, GP-GM) or **clay** (GW-GC, GP-GC)²
5. If the soil contains \geq 15% silt or clay, then the soil is **silty** or **clayey sand** (SM or SC) or **silty** or **clayey gravel** (GM or GC); the grading modifiers are not used
6. If the soil is sand and contains > 15% gravel, add “**with gravel**” to the classification, e.g., **poorly graded sand with gravel** (SP)
7. If the soil is gravel and contains \geq 15% sand, add “**with sand**” to the classification, e.g., **well-graded gravel with silt and sand** (GW-GM)

¹ Based on ASTM D2488-09a, Standard Practice for Description and Identification of Soils (Visual–Manual Procedure)

² Dual symbols (two symbols separated by a hyphen, e.g., SP-SM) must be used when the soil has between 5% and 12% fines or when the liquid limit and plasticity index values plot in the CL-ML (silty clay) area of the plasticity chart. Dual symbols are not the same as borderline symbols (two symbols separated by a forward slash, e.g., CL/CH) which should be used to indicate that soil exhibits properties that do not distinctly place it into a specific group (Appendix X3).

Well Development

FSOP 2.2.1 (July 14, 2020)

Ohio EPA Division of Environmental Response and Revitalization

1.0 Scope and Applicability

- 1.1 This field standard operating procedure (FSOP) describes standard monitoring well development practices used by the Ohio EPA Division of Environmental Response and Revitalization (DERR) for both newly installed wells and redevelopment of existing wells. Monitoring wells installed and/or developed by DERR are typically 0.5-inch to 2.0-inch inside-diameter wells. The practices and equipment discussed in this procedure focus on effective development of small-diameter wells used for ground water sampling.
- 1.2 The practices and equipment described herein may or may not be appropriate for the development of larger (> 2.0-inch inside diameter) wells used for aquifer testing, ground water remediation, gradient control, or water supply purposes (ASTM, 2018). For such situations this FSOP may serve as only a general guidance. Development of larger diameter wells may require techniques or equipment that are not discussed in this FSOP. Additional reference materials may need to be reviewed, and the site-specific work plan may need to specify additional well development procedures.
- 1.3 Monitoring well development is performed to (1) remove fluids that may have been added during drilling or during the well construction process, (2) remove fine sediment from the vicinity of the well screen, and (3) ensure good hydraulic interconnection between the sand filter pack and the adjacent geologic materials (formation) in which the well screen is installed. Proper development is especially critical for wells used to evaluate turbidity-sensitive ground water constituents such as metals, and for wells used to evaluate hydraulic conductivity or ground water yield (Ohio EPA TGM, February 2009).
- 1.4 The terms “well development” and “well purging” (the removal of water from a well) are not synonymous. While purging is an integral part of the overall well development effort, simply purging a monitoring well generally does not provide adequate development of the filter pack and surrounding formation.
- 1.5 For the purposes of this FSOP, development techniques include (1) surging and pumping, (2) purging with an inertial lift pump, (3) over-pumping, and (4) bailing:
 - 1.5.1 Surging and pumping may be performed using an electric submersible pump or a bladder pump with or without a surge block. The surge block may be a separate assembly or attached to the pump assembly. If a surge block is not available, then the pump must be of sufficient diameter and weight to effectively surge the well. “Surging” means forcing the flow of water back and forth through the filter pack. This action optimizes the hydraulic interconnection between the well and surrounding formation by (1) removing fine sediments and (2) grading (sorting) and stabilizing the filter pack and adjacent (unconsolidated) formation. Pumping may be performed during or after surging. Surging and pumping is the preferred

technique for wells installed in bedrock, gravel, or sand. This technique should not be used for wells installed in silt or clay.

- 1.5.2 Purging with a manually operated inertial lift pump (e.g., a Waterra Pump™) may be used to develop monitoring wells installed in bedrock, gravel, sand, silt, or clay. This method is very effective and may be applied over a wider range of formation materials.
- 1.5.3 A surge block attachment may be used in wells with screens set mostly in bedrock, gravel, or sand. The attachment may also be used in wells with screens set mostly in silt if surging is performed gently for a short duration (e.g., three one-minute intervals). The surge block attachment should not be used when developing wells that screen mostly clay.
- 1.5.4 Over-pumping is the process of repeatedly pumping the monitoring well at a relatively high rate (as compared to the well yield) to rapidly draw down the water level as far as possible, and then turning off the pump and allowing the well to recharge. Over-pumping may be performed with a submersible pump or peristaltic pump (depending on the well yield). This technique will remove fine sediments from the well casing and filter pack but does not grade (sort) the filter pack, and therefore develops the well less effectively than surging and pumping or an inertial lift pump with a surge block. In addition, it is generally less effective than an inertial lift pump at removing sediment that has accumulated at the bottom of the well screen. Over-pumping is an acceptable alternative for wells that screen mostly silt or clay.
- 1.6 Bailing can be used to develop monitoring wells installed in bedrock, gravel, sand, silt, and clay. However, bailing is not a very effective well development technique and should generally be avoided. Surging and pumping or purging with an inertial lift pump are much more effective techniques for wells that screen mostly bedrock, gravel, or sand. For wells that screen mostly silt or clay, purging with an inertial lift pump or over-pumping are likely to produce better results.
- 1.7 Development techniques and documentation should support the project data quality objectives and work plan. Requirements for well development are in part project-specific, and therefore the specific technique, level of effort, and associated data will vary between projects and sites. Not all information on the DERR Monitoring Well Development Form will be applicable to every project or site.

2.0 Definitions

Not applicable

3.0 Health and Safety Considerations

- 3.1 Always review the site-specific health and safety plan (HASP) before performing well development activities. The HASP should address any site-specific hazardous that may be associated with well development activities.
- 3.2 Due to likelihood of direct contact with ground water during well development, eye and dermal protection are strongly recommended.
- 3.3 If concerns exist regarding potentially toxic or explosive atmospheres within the well casings, open each monitoring well and screen the atmosphere (1) within the breathing zone above the open well casing and (2) within the well casing with a PID and/or LEL/O₂ meter.
- 3.4 If a portable generator is being used to operate a development pump, ensure that the generator is properly grounded to avoid electric shock.

4.0 Procedure Cautions

- 4.1 If a monitoring well has been installed using liquid grout to seal the annular space above the filter pack, well development activities should not be performed until the grout has set for at least 24 hours. Otherwise, development activities could damage the well by drawing uncured grout into the filter pack and well screen.
- 4.2 Monitoring wells that contain nonaqueous phase liquids (NAPL) should not be developed. Typically, the presence of NAPL is confirmed if an immiscible fluid layer at least 0.01 inches thick can be detected with an interface probe or clear bailer. Often, NAPL occurs in a discrete layer within the screened formation. Well development will distribute the NAPL throughout the filter pack and surrounding formation and generate purge water that is time-consuming and costly to dispose. In addition, development will likely cause subsequent NAPL recovery efforts to be more difficult and compromise any attempt to collect a representative ground water sample from the well.
- 4.3 Excessively or vigorously surging a monitoring well can permanently damage the filter pack. As a general rule, small-diameter wells should not be surged for a time interval longer than three minutes before pumping or manually purging sediment-laden water from the well and should not be surged for more than 15 minutes in total. Surging always should be performed slowly and gently.
- 4.4 As a general rule, monitoring wells that screen mostly clayey silt or clay should not be surged, because an excessive amount of fine sediment could be drawn into the filter pack and significantly reduce the hydraulic interconnection between the well and surrounding formation. Removing such sediment from the filter pack is very difficult, if not impossible. If surging is deemed necessary based on well performance concerns, it should be performed very slowly and gently and for short time intervals (*e.g.*, no more than three one-minute intervals), each followed by evacuation of at least one well volume to remove sediment from the well.

- 4.5 Stainless-steel, weighted non-disposable PVC or Polyethylene bailers should be used for well development. Disposable Teflon or PVC bailers designed for ground water sampling should not be used for well development.
- 4.6 If the measured total depth of a monitoring well indicates that more than 10 percent of the screen has filled with sediment, excess sediment should be removed by using a bailer or inertial lift pump before lowering an electric submersible pump or bladder pump into the well. Operation of an electric submersible pump or bladder pump in a well with significant sediment accumulation may result in the pump becoming lodged ("sand locked") within the well screen or casing. Additionally, an excessive sediment load can damage the internal components of some electric submersible pumps.

5.0 Personnel Qualifications

Ohio EPA personnel working at sites that fall under the scope of OSHA's hazardous waste operations and emergency response standard (29 CFR 1910.120) must meet the training requirements described in that standard. In addition, field staff assigned to perform monitoring well development should be DERR or Division of Drinking and Ground Water personnel who have a background in hydrogeology and/or well development experience.

6.0 Equipment and Supplies

- 6.1 Equipment and supplies needed for every well development event regardless of technique or site-specific criteria:
 - 6.1.1 Boring logs and well construction diagrams
 - 6.1.2 Decontamination equipment and supplies (refer to FSOP 1.6, Sampling Equipment Decontamination)
 - 6.1.3 Graduated bucket or other container to estimate purge volumes
 - 6.1.4 Personal protective equipment (protective eyewear, gloves, and footwear at a minimum)
 - 6.1.5 Plastic sheeting
 - 6.1.6 Purge water containers
 - 6.1.7 Watch or cell phone
 - 6.1.8 Water level meter
 - 6.1.9 DERR Monitoring Well Development Form
- 6.2 Equipment and supplies needed for well development depending on the technique or site-specific criteria:
 - 6.2.1 Bladder pump system
 - 6.2.2 Electric submersible pump system
 - 6.2.3 Inertial lift pump system
 - 6.2.4 Peristaltic pump system
 - 6.2.5 Pump-specific tubing
 - 6.2.6 Monitoring instruments required to evaluate the following purge water

- stabilization parameters: temperature, pH, specific conductance (conductivity), oxidation/reduction potential, turbidity, or dissolved oxygen
- 6.2.7 Photoionization Detector (PID) and/or Lower Explosive Limit/Oxygen (LEL/O₂) meter for health and safety monitoring
 - 6.2.8 Stainless steel or PVC bailer (and bailer rope)
 - 6.2.9 Surge block

7.0 Procedures

- 7.1 Review the boring log(s) and well construction diagram(s) to determine the most appropriate well development technique.
- 7.2 Well development data should be recorded using the DERR Monitoring Well Development Form (attached).
- 7.3 Deviations from this procedure should be documented with a brief explanation of the reason(s) for the deviation.
- 7.4 Initial field activities:
 - 7.4.1 If concerns exist regarding potentially toxic or explosive atmospheres within the well casings, open each monitoring well and screen the atmosphere (1) within the breathing zone above the open well casing and (2) within the well casing with a PID and/or LEL/O₂ meter.
 - 7.4.1.1 If volatile organic compound (VOC) concentrations or the percentage LEL *in the breathing zone* exceed the health and safety action levels provided in Table 1 of FSOP 1.1, Initial Site Entry or site-specific action levels, close and secure the monitoring well. Development of the well will need to be delayed until appropriate health and safety measures can be implemented.
 - 7.4.1.2 If VOC concentrations or the percentage LEL *in the well casing* exceed the health and safety action levels provided in Table 1 of FSOP 1.1 or site-specific action levels but VOC concentrations or the percentage LEL in the breathing zone do not, allow the well to vent. Continue monitoring the breathing zone as necessary while performing well development activities.
 - 7.4.1.3 Record health and safety monitoring data using the DERR Monitoring Well Development Form or a field logbook or field log sheets (e.g., ranges of PID and LEL measurement values).
 - 7.4.2 Measure the static water level and total depth of each well scheduled to be developed that day. Record these data using the DERR Monitoring Well Development Form.
 - 7.4.3 Calculate the volume of the static water column in each well scheduled to be developed. At least three well volumes must be removed from every well for development efforts to be considered complete (refer to Step

7.3.5). Further, stabilization parameters should be monitored based on well volumes (rather than arbitrary time intervals) to avoid purging too little water between successive stabilization parameter measurements and prematurely concluding that purge water stabilization has been attained (refer to Step 7.4.2).

$$\text{One Well Volume (gal)} = (\text{Total Depth, ft} - \text{Static Water Level, ft}) \times 3.14 \times (\text{Well Radius, ft})^2 \times 7.48 \text{ gal/ft}^3$$

$$\text{One Well Volume (L)} = (\text{Total Depth, ft} - \text{Static Water Level, ft}) \times 3.14 \times (\text{Well Radius, ft})^2 \times 28.32 \text{ L/ft}^3$$

The following table summarizes volume (gallons and liters) per foot (of casing/screen length) for 0.5- to 4-inch inside diameters wells:

Well Inside Diameter (inches)	Volume per Foot (gallons)	Volume per Foot (liters)
0.5	0.01	0.04
0.75	0.02	0.09
1.0	0.04	0.15
1.5	0.09	0.35
2.0	0.16	0.62
3.0	0.37	1.39
4.0	0.65	2.47

Ideally, one “well volume” should include the water contained in the filter pack surrounding the screen. However, the filter pack contribution is typically less than 25 percent of the total well volume, and therefore is not a critical consideration for well development in most situations. Either well volume calculation (with or without the filter pack contribution) may be used at the discretion of the District Office Site Coordinator (based on the recommendation of the DDAGW Geologist assigned to the site.) If the District Office Site Coordinator does not indicate a preference, SIFU staff will decide based on their best professional judgment. Calculating the well volume with filter pack contribution requires the saturated length of the filter pack interval (which is usually longer than the screen), the boring diameter, and an estimation of the filter pack porosity (typically 25 to 30 percent):

$$\text{One Well Volume Including Filter Pack (gal)} = [(\text{Total Depth, ft} - \text{Static Water Level, ft}) \times 3.14 \times (\text{Well Radius, ft})^2] \times 7.48 \text{ gal/ft}^3 + [\text{Filter Pack Length, ft} \times 3.14 \times ((\text{Boring Radius, ft})^2 - (\text{Well Radius, ft})^2) \times 0.25 \text{ or } 0.30] \times 7.48 \text{ gal/ft}^3$$

- 7.4.4 Calibrate all field monitoring equipment that will be used for well development.
 - 7.4.5 At each well location, set up the well development equipment on a plastic sheet to avoid possible cross contamination through direct contact with the ground. Clean 5-gallon buckets may be used to hold pump hoses, air lines, bailer rope, etc.
 - 7.4.6 Compare the total depth measurement to the total depth shown on the well construction diagram. If the measured total depth indicates that more than 10 percent of the screen has filled with sediment, remove the excess sediment by using a bailer or an inertial lift pump before lowering an electric submersible pump into the well.
- 7.5 Specific procedures for development techniques:
- 7.5.1 Surging and pumping: start at the top of the well screen and gradually work downwards in 2 to 3 foot intervals to the bottom of the well, surging slowly with a surge block, a pump equipped with a surge block, or the pump itself. Surge for two to three minutes and then pump the well to remove at least one well volume of sediment-laden water. After repeating this process three to five times, continue to pump the well at a sustainable rate.
 - 7.5.2 Inertial lift pump:
 - 7.5.2.1 If using an inertial lift pump with a surge block attachment, start at the top of the well screen and gradually work downwards in 2 to 3-foot intervals to the bottom of the well, surging slowly. Surge and purge for two to three minutes to remove at least one well volume of sediment-laden water. After repeating this process three to five times, continue to purge the well at a sustainable rate. The pump foot valve should be within 2 inches of the bottom of the well during purging to remove sediment.
 - 7.5.2.2 If using an inertial lift pump without a surge block attachment, purge the well at a sustainable rate. The pump foot valve should be within 2 inches of the bottom of the well during purging to remove sediment.
 - 7.5.3 Over-pumping: lower the pump intake to the top of the well screen. Purge the well at a pumping rate high enough to drawdown the water level to the pump intake. Turn off the pump, allowing the water level in the well to recover to at least two feet above the pump intake. Lower the pump approximately two feet deeper into the well screen and repeat the process. After repeating this process three to five times, continue to purge the well at a sustainable rate.

7.5.4 Bailing:

7.5.4.1 If using a bailer to develop a monitoring well installed in bedrock, gravel, sand, sandy silt, or silt, surge the screened interval with the bailer, using the same method as described in paragraph 7.3.1 above. While surging, *gently* tap the bailer on the bottom of the well to remove sediment. Remove at least one well volume of water after each period of surging. Continue to bail the well at a sustainable rate; bail from the top of the water column (do not lower the bailer into the screened interval) to avoid resurging the filter pack and re-elevating the turbidity.

7.5.4.2 If using a bailer to develop a monitoring well installed in silty clay or clay, initially purge the well by lowering the bailer to the bottom of the well for each withdrawal so that it is lowered and raised through the entire length of the well screen (*do not surge as described in Step 7.3.1 above*). *Gently* tap the bailer on the bottom of the well to remove sediment. After three well volumes have been removed, continue to bail the well at a sustainable rate. Bail from the top of the water column (do not lower the bailer into the screened interval) to avoid resurging the filter pack and re-elevating the turbidity.

7.5.5 Continue well development using one or more of the procedures described above until (1) the sediment thickness remaining in the wells is less than 1 percent of the screen length or 0.1 ft (whichever is larger), (2) required purge-water stabilization parameters have stabilized, and (3) at least three well volumes of purge water have been removed.

7.5.6 Record well development procedures and the volume of water removed from the well using the DERR Monitoring Well Development Form.

7.6 Stabilization parameter monitoring:

7.6.1 The use of temperature, pH, and specific conductance as purge water stabilization parameters for well development is strongly recommended. Depending on the project data quality objectives and associated work plan requirements, stabilization parameters may include temperature, pH, conductivity, oxidation-reduction potential, turbidity, or dissolved oxygen. If the work plan does not include well development stabilization parameters, the District Office Site Coordinator will decide which, if any, stabilization parameters will be monitored (based on the recommendation of the DDAGW Geologist assigned to the site.) If the District Office Site Coordinator does not indicate a preference, stabilization parameters will be monitored at the discretion of SIFU staff.

7.6.2 Once the parameters have stabilized, collect at least three successive measurements for each parameter to evaluate stabilization criteria. At least one well volume should be purged from the monitoring well prior to each successive measurement.

The following table summarizes purge water stabilization criteria:

Purge Water Parameters	Stabilization Criteria
Temperature	0.5° C
pH	+/- 0.2 Standard Units (S.U.)
Specific Conductance	+/- 3%
Oxidation-Reduction Potential (ORP)	+/- 20 millivolts (mV)
Purge Water Parameters	Stabilization Criteria
Turbidity	< 10 Nephelometric Turbidity Units (NTUs) or +/- 10% for turbidity > or = 10 NTUs
Dissolved Oxygen (DO)	+/- 10% or 0.2 mg/l, whichever is greater

- 7.7 Water level and pumping/purging rate monitoring:
- 7.7.1 Monitoring the water level in the well is recommended during well development activities if possible. Record water level data using the DERR Monitoring Well Development Form.
 - 7.7.2 Monitoring the pumping or purging rate is recommended during well development activities if possible. Record data for calculating pumping or purging rates (water volumes withdrawn over time) using the DERR Monitoring Well Development Form.
 - 7.7.3 Water level data and pumping or purging rates can provide general information about the formation hydraulic conductivity and the well yield, which in turn may be helpful for selecting appropriate ground water sampling techniques or for locating additional monitoring wells during future assessment activities.
- 7.8 Upon completion of well development activities, ensure that each well is properly closed and secured.
- 7.9 Purge water and other waste disposal:
- 7.9.1 Refer to FSOP 1.7, Investigation Derived Wastes.
 - 7.9.2 Well development water with concentrations of petroleum or hazardous substances exceeding Voluntary Action Program generic potable use standards [OAC 3745-300-08(D)(3)] must be containerized and properly disposed.

- 7.9.3 If well development water is suspected to be a hazardous waste, contact SIFU for assistance.
- 7.10 Monitoring well redevelopment is needed if more than 10 percent of the screened interval has filled with sediment. In addition, redevelopment may be needed if:
 - 7.10.1 The well produces excessively turbid water as compared to the turbidity typically observed or measured during prior sampling events.
 - 7.10.2 The well exhibits anomalously high or low water levels as compared to its range of historic water levels, or significantly slower recharge rates than expected.
 - 7.10.3 The well casing or surface seal is damaged and subsequently repaired. Surface water, soil, or other foreign materials may have entered the well after it was damaged and/or during its repair. Use of a downhole camera may be used to evaluate whether a well has been damaged.

8.0 Data and Records Management

Refer to FSOP 1.3, Field Documentation.

9.0 Quality Assurance and Quality Control

Not applicable

10.0 Attachments

DERR Monitoring Well Development Form

11.0 References

ASTM, D5521 / D5521M-18, Standard Guide for Development of Groundwater Monitoring Wells in Granular Aquifers, ASTM International, 2018, [www.astm.org
http://www.astm.org/cgi-bin/resolver.cgi?D5521D5521M](http://www.astm.org/cgi-bin/resolver.cgi?D5521D5521M)

FSOP 1.1, Initial Site Entry

FSOP 1.3, Field Documentation

FSOP 1.6, Sampling Equipment Decontamination

FSOP 1.7, Investigation Derived Wastes

FSOP 3.1.2, Multiple Gas Detection Meter

Ohio EPA Division of Drinking and Ground Waters, 2009, Technical Guidance Manual for Ground Water Investigations (Chapter 8: Well Development, Maintenance, and Redevelopment)

Ground Water Level Measurement

FSOP 2.2.2 (July 20, 2020)

Ohio EPA Division of Environmental Response and Revitalization

1.0 Scope and Applicability

- 1.1 Measurement of ground water levels from wells or piezometers is generally required to:
- Provide static water level data to prepare a potentiometric surface map and evaluate ground water flow direction
 - Determine the depth to set a ground water sampling pump
 - Estimate the volume of water to be purged from the well prior to sampling
 - Monitor water level drawdown while purging and sampling or during aquifer testing
- 1.2 This FSOP is applicable to the measurement of ground water levels with an electronic water level indicator (refer to FSOP 3.1.4, Electronic Water Level Indicator) in monitoring wells, piezometers, water supply wells, soil gas probes and soil borings that intersect the water table.
- 1.3 Measuring water levels may be difficult in some situations, including small-diameter (< 1 inch) monitoring wells, piezometers or soil gas probes. In addition, water supply wells may not provide access for water level measurements and often contain a dedicated pump with plumbing and electrical wiring that can obstruct or entangle a water level probe or pressure transducer.

2.0 Definitions

Not applicable

3.0 Health and Safety Considerations

- 3.1 Consult the instrument's operation manual to determine if it is intrinsically safe when working in an area where there is a potential fire or explosion hazard.
- 3.2 Always review the site-specific health and safety plan (HASP) for site-specific sampling hazards before beginning work.

4.0 Procedure Cautions

- 4.1 The user should be familiar with the instrument operation. Consult the instrument manual for operating instructions prior to use.
- 4.2 Inspect the instrument tape for cuts or abrasions.
- 4.3 If concerns exist regarding potentially toxic or explosive atmospheres within the well casings, open each monitoring well and screen the atmosphere (1) within the breathing zone above the open well casing and (2) within the well casing with

a PID and/or LEL/O₂ meter. (Refer to FSOP 3.1.1, Photoionization Detector and FSOP 3.1.2, and FSOP 3.1.2, Multiple Gas Detection Meter.)

- 4.3.1** If volatile organic compound (VOC) concentrations or the percentage LEL *in the breathing zone* exceed the health and safety action levels provided in Table 1 of FSOP 1.1, Initial Site Entry or site-specific action levels, close and secure the monitoring well. Development of the well will need to be delayed until appropriate health and safety measures can be implemented.
- 4.3.2** If VOC concentrations or the percentage LEL *in the well casing* exceed the health and safety action levels provided in Table 1 of FSOP 1.1 or site-specific action levels but VOC concentrations or the percentage LEL in the breathing zone do not, allow the well to vent for a few minutes and then measure the LEL again. If the LEL is less than the action level, proceed with the measurement.
- 4.3.3** Record health and safety monitoring data using the DERR Monitoring Well Development Form or a field logbook or field log sheets (*e.g.*, ranges of PID and LEL measurement values).
- 4.4** The use of electronic water level indicators to measure the depth to water in residential or other wells with pumps and associated plumbing is discouraged, because the tape may become entangled in the downhole plumbing or centralizing disks. If water level measurements must be obtained from such wells, the pump and plumbing may need to be temporarily removed first, which usually requires the services of a registered water well drilling contractor. Additional disinfection of the well and/or downhole equipment may be required by the county or local health department that has jurisdiction over the well.
- 4.5** Use caution when lowering and raising the tape within a well. A sharp casing edge or burr may damage the tape if it is pulled against the edge of the casing.
- 4.6** Do not use electronic water level indicators in wells known or suspected to contain nonaqueous phase liquids (NAPL). Use an interface meter instead (refer to FSOP 3.1.3, Interface Meter).
- 4.7** If using the water level indicator to measure the total depth of the well, add the length of any probe extension beyond the sensor pin (*e.g.*, 0.3 ft) to obtain an accurate measurement of the total well depth.
- 4.8** Be sure the instrument has charged batteries. Bring spare batteries.
- 4.9** Remove the batteries if the instrument is not going to be used for an extended period of time.

- 4.10** When reeling the tape in, be careful that the tape does not twist, kink or fold. The tape protection device (attached to the reel) should be used to prevent abrasion while the probe is in the well.
- 4.11** Always transport the instrument in a protective case or secure the instrument during transport.

5.0 Personnel Qualifications

Ohio EPA personnel working at sites that fall under the scope of OSHA's hazardous waste operations and emergency response standard (29 CFR 1910.120) must meet the training requirements described in that standard.

6.0 Equipment and Supplies

- 6.1** Water level indicator with battery and operation manual
- 6.2** Protective case for instrument transport
- 6.3** Data forms or field book and pen
- 6.4** Well keys and tools needed to open well(s)
- 6.5** Decontamination equipment and supplies
- 6.6** Personal protective equipment appropriate for site-specific work activities

7.0 Procedure

- 7.1** Make sure the electronic water level indicator is functioning properly and the battery is charged. When testing the instrument, use tap water and not distilled water. Distilled water contains no dissolved solids to act as electrolytes and the alarms will not be activated.
- 7.2** Open the well. Allow sufficient time for the water level to equilibrate, especially if the well is installed in a confined aquifer or if air pressure is released (a "pop" is heard) when the well casing cap is removed.
- 7.3** Locate the designated measuring point mark on the casing. For monitoring wells this is generally marked on the highest point or north side of the top of the inner casing. If a mark is not present, use the highest visible point of the inner casing as the measuring point. If the inner casing is level (no discernible high point), use the north side of the casing. In either case mark a new measuring point.
- 7.4** Turn the water level indicator's switch on to the highest sensitivity position. Press the test button to ensure battery and alarm function.
- 7.5** Slowly lower the tape down the well, taking caution not to twist the tape or allow the tape to scrape the edge of the casing as it is being lowered. When the probe contacts water, the instrument's audible and visual alarms will be activated.
- 7.6** Raise the tape slightly to lift the probe out of the water. The alarm should stop. A mild shake of the tape may be necessary to remove water from the probe's

sensor pin. Lower the tape slightly until the alarms activate and hold the tape firmly against the side of the casing so that the probe does not move up or down.

- 7.7** Carefully read the tape measurement at the well's measuring point to the nearest hundredth of a foot (0.01 ft) and verify.
- 7.8** Record the water level reading.
- 7.9** If using the water level indicator to measure the total depth of the well, turn off the instrument. Next, lower the tape to the bottom of the well and record the tape reading at the measuring point. Remember to add the length of any probe extension to the total depth measurement.
- 7.10** Decontaminate the probe and the length of tape lowered into the well in accordance with the decontamination procedures specified in FSOP 1.6, Sampling Equipment Decontamination or the site specific work plan. Use deionized water and a paper towel to wipe the tape as you reel it up from the well.

8.0 Data and Records Management

Refer to FSOP 1.3, Field Documentation.

9.0 Quality Assurance and Quality Control

Not applicable

10.0 Attachments

None

11.0 References

FSOP 1.1, Initial Site Entry

FSOP 1.3, Field Documentation

FSOP 1.6, Sampling Equipment Decontamination

FSOP 3.1.1, Photoionization Detector

FSOP 3.1.2, Multiple Gas Detection Meter

FSOP 3.1.3, Interface Meter

FSOP 3.1.4, Electronic Water Level Indicator

Ground Water Sampling (General Practices)

FSOP 2.2.4 (August 4, 2020)

Ohio EPA Division of Environmental Response and Revitalization

1.0 Scope and Applicability

1.1 This procedure describes general standard practices that should be used by the Division of Environmental Response and Revitalization (DERR) for collecting ground water samples from monitoring wells and soil borings, regardless of the technique or sampling equipment used. These procedures may be used for collecting ground water samples for screening, compliance or other objectives. Applicable ground water sampling techniques include the following:

- FSOP 2.2.5, Ground Water Sampling Using an Inertial Lift (Check Valve) Pump
- FSOP 2.2.6, Low-Flow (Low-Stress) Ground Water Sampling
- FSOP 2.2.7, Ground Water Sampling Using a Bailer
- FSOP 2.2.8, Ground Water Sampling Using a Bladder Pump
- FSOP 2.2.9, Ground Water Sampling Using a Peristaltic Pump
- FSOP 2.2.10, Ground Water Sampling Using an Electric Submersible Pump
- FSOP 2.2.11, Sampling Water Supply Systems

1.2 All ground water sampling techniques and associated procedures should be consistent with Ohio EPA's Technical Guidance Manual (TGM) for Hydrogeologic Investigations and Ground Water Monitoring, specifically Chapter 10, Ground Water Sampling. In addition, U.S. EPA 2002 (Yeskis and Zavala) provides ground water sampling guidance for RCRA and CERCLA sites. The site-specific work plan (SSWP) will provide project objectives and data quality objectives (DQOs). In the event there appears to be inconsistency between the TGM and project objectives or DQOs, please contact the DERR SIFU manager and DERR site coordinator for clarification.

2.0 Definitions

2.1 Ground Water Screening Sample: a ground water sample used for site assessment decision-making purposes, as opposed to a ground water compliance sample collected for modeling, risk assessment or to evaluate regulatory compliance. Ground water screening samples may be used for optimizing the location and construction of monitoring wells, selecting ground water samples for fixed-base laboratory analysis, installing additional investigatory soil borings, or as the basis for sampling other environmental media such as soil vapor. Ground water screening samples may be collected from monitoring wells, piezometers, soil borings, sumps or excavations, and do not necessarily need to meet the strict ground water purging and stabilization requirements for ground water compliance samples as described below in paragraph 2.2.

- 2.2 Ground Water Compliance Sample: a representative ground water sample intended to support regulatory compliance, risk assessment or modeling. Ideally, this type of sample is collected in a manner that minimizes disturbance to ambient ground water chemical and physical properties and is representative of in-situ ground water quality within the saturated zone or aquifer of interest. These samples are collected from properly constructed and developed monitoring wells and must meet strict ground water purging and stabilization requirements. Unless otherwise indicated in this FSOP, the terms “ground water sample” or “sample” refer to this type of ground water compliance sample.

3.0 Health and Safety Considerations

- 3.1 Always review the site-specific health and safety plan (HASP) for sampling hazards before beginning work.
- 3.2 If required by the SSWP or HASP, or if concerns exist regarding potentially toxic or explosive atmospheres within the well, monitor the breathing zone above the open well casing and the well casing atmosphere with a photoionization detector (PID), multiple gas detection meter, *i.e.*, a meter with lower explosive limit (LEL) and oxygen (O₂) measurement capabilities or other required instrument. Breathing zone action levels are provided in Table 1 of FSOP 1.1, Initial Site Entry.
- 3.3 Wear appropriate personal protective equipment (PPE) when performing ground water sampling activities, including but not limited to chemical-resistant gloves compatible with the contaminants of concern, and eye/face protection and coveralls for splash protection.
- 3.4 Use caution when handling glass sample containers and chemical preservatives.
- 3.5 Use caution and wear work gloves when assembling or disassembling equipment and cutting discharge tubing.

4.0 Procedure Cautions

- 4.1 If non-aqueous phase liquid (NAPL) is present in the well, notify the DERR site coordinator and refer to FSOP 2.2.3, Detection and Sampling of Nonaqueous Phase Liquids in Monitoring Wells.
- 4.2 At minimum, wells should be redeveloped when 20% of a well screen is occluded by sediments, or records indicate a change in yield and turbidity. Wells should be redeveloped per FSOP 2.2.1, Well Development to obtain a representative sample.
- 4.3 Use the low-flow sampling technique (FSOP 2.2.6) to sample low-yielding (100 ml/min to 500 ml/min) wells whenever possible.

- 4.4 For very low-yielding wells (< 100 ml/min), sample collection options include no purge sampling, purging the well dry and allowing it to recover or using a passive ground water sampling device. The SSWP should provide specific procedures for sampling very low yielding wells. If it does not and very low-yielding wells need to be sampled, contact the DERR SIFU manager and DERR site coordinator to provide sampling procedures appropriate for project objectives and DQOs.
- 4.5 Avoid collecting ground water samples with bailers (FSOP 2.2.7) whenever possible to prevent elevated sample turbidity and sample volatilization.
- 4.6 Be aware that peristaltic pumps (FSOP 2.2.9) create a vacuum to pull ground water from a well. Based on site-specific data quality objectives (DQOs), use of a peristaltic pump may or may not be appropriate for collecting ground water compliance samples for volatile organic compounds (VOCs), semi-volatile organic compounds (SVOCs), dissolved metals or dissolved gases.
- 4.7 Prolonged purging at a rate that exceeds a well's yield will result in ground water cascading within the screened interval, causing volatilization and oxidation of contaminants and inhibiting the ability to collect a representative ground water sample.
- 4.8 When filling pre-preserved ground water sample containers, be careful not to flush out chemical preservatives.
- 4.9 When collecting samples for volatile organic compound (VOC) analysis, the 40-ml sample container should be filled slowly and gently (at rate of 100 ml/min or less) to minimize sample agitation and aeration and associated loss of VOCs, regardless of the specific sampling technique used.

5.0 Personnel Qualifications

Ohio EPA personnel working at sites that fall under the scope of OSHA's hazardous waste operations and emergency response standard (29 CFR 1910.120) must meet the training requirements described in that standard.

6.0 Equipment and Supplies

- Sample containers and preservatives
- Sample coolers and ice
- Sample labels
- PPE including at a minimum, chemical-resistant gloves
- Paper towels
- Decontamination equipment and supplies
- Purge water containers
- Field forms and/or logbook
- Chain-of-custody (COC) forms
- Pens and markers

- Calculator
- Water quality meter(s) to measure pH, temperature, specific conductance, oxidation-reduction potential (ORP), dissolved oxygen, turbidity and/or other water quality parameters
- Purging and sampling equipment (pumps, or bailers)
- Tubing (if needed)
- Electrical power source (car batteries or generator, if needed)

7.0 Procedures

7.1 Pre-sampling inspection and field monitoring

7.1.1 Document weather and other field conditions that could affect ground water sample activities and sample representativeness.

7.1.2 Inspect each monitoring well to evaluate and document the following conditions:

- Is the well secured (locked)?
- Is the well labeled?
- Are there insects (e.g., wasps) or rodents (e.g., mice) living inside the protective casing?
- Is the well damaged, or does it appear to have been tampered with?

7.1.3 If required by the SSWP or HASP, or if concerns exist regarding potentially toxic or explosive atmospheres within the well, monitor the breathing zone above the open well casing and the well casing atmosphere with a photoionization detector (PID), multiple gas detection meter (with LEL/O₂ capabilities) or other required instrument. Breathing zone action levels are provided in Table 1 of FSOP 1.1, Initial Site Entry. Monitoring may need to continue during purging and sampling activities. Additionally, if the LEL is exceeded inside the well casing, allow the open well to ventilate and measure the LEL again. Allow the LEL concentration to drop to below the LEL before placing instrumentation or sampling devices inside the well. Refer to FSOP 3.1.1, Photoionization Detector and FSOP 3.1.2, Multiple Gas Detection Meter for use and operation of these instruments.

7.2 Static water level and total depth measurements

7.2.1 Allow sufficient time for the water level to equilibrate (at least 10 to 15 minutes) if the well is installed in a confined saturated zone, or if air pressure is released (a popping sound is heard) when the well cap is removed.

7.2.2 Measure the static water level and total depth in accordance with FSOP 2.2.2, Ground Water Level Measurement. The static water level should

be measured to an accuracy of +/- 0.01 ft, and the total depth should be measured to an accuracy of +/- 0.1 ft.

- 7.2.3 If NAPL is present in the well, following the monitoring procedures provided by FSOP 2.2.3, Detection and Sampling of Nonaqueous Phase Liquids in Monitoring Wells. In addition, immediately notify the DERR SIFU manager and DERR site coordinator.

7.3 Purging

- 7.3.1 Set up ground water purging and sampling equipment ensuring that:

- The work area is organized to maximize efficiency and minimize the potential for cross contamination.
- Non-disposable down-well equipment has been decontaminated.
- Monitoring equipment is properly calibrated.
- Preserved sample containers are ready for use.
- Field forms and sample labels are ready for use.

- 7.3.2 Purging for volumetric sampling techniques (e.g. bailing or high-flow pumping) is based on well volumes, i.e., the volume of water present in the screen and well casing under static water level conditions. At a minimum, three well volumes should be purged before sampling unless the well goes dry. However, the SSWP may require collecting:

- More than three well volumes
- A specified number of well volumes (three or more) with selected water quality parameters (refer to paragraph 7.3.4)
- A variable number of well volumes (three or more) based on selected water quality parameter stabilization (refer to paragraph 7.3.4)

One well volume can be calculated based on the well depth, well diameter and ground water depth using the following equation:

One Well Volume (gallons) = $D^2/4 \times 3.14 \times (Hd - Hw) \times 7.48 \text{ gal/ft}^3$,
where

D = well diameter, ft

Hd = well depth, ft top-of-casing (TOC)

Hw = static water depth, ft TOC

Alternatively, the following well diameter-based conversion factors (see quick reference guide in table below) can be multiplied by the static water column length (**Hd - Hw**) to determine the well volume in gallons or milliliters (1 gallon = 3,784.41 milliliters):

Well Diameter (Inches)	Gallons Per Foot	Milliliters Per Foot
0.5	0.01	39
0.75	0.02	87
1.0	0.04	154
1.5	0.09	347
2.0	0.16	617
3.0	0.37	1,389
4.0	0.65	2,470
5.0	1.02	3,859
6.0	1.47	5,557
8.0	2.61	9,879

- 7.3.3 Purging for the low-flow (low-stress) ground water sampling technique is based on the stabilization of water quality parameters to determine when to begin sampling. The SSWP will indicate at least three specific stabilization parameters to be monitored. In addition, water level drawdown in the well should be minimized, with the pumping level stabilized above the screened interval (unless the static water level is within the screened interval). At least one equipment volume (pump and discharge line volume) should be evacuated between stabilization parameter measurements unless a greater volume is required by the SSWP Refer to FSOP 2.2.6, Low-Flow (Low-Stress) Ground Water Sampling.
- 7.3.4 The SSWP will indicate the water quality stabilization parameters that need to be monitored prior to sample collection. Ground water stabilization parameters and criteria include the following:

Stabilization Parameters	Criteria (for at least three consecutive measurements)
Temperature	+/- 0.5° C
pH	+/- 0.2 standard units (S.U.)
Specific Conductance	+/- 3%
Oxidation-Reduction Potential	+/- 20 millivolts (mV)

Stabilization Parameters	Criteria (<u>for at least three consecutive measurements</u>)
Dissolved Oxygen	+/- 0.3 mg/L
Turbidity	< 10 nephelometric turbidity units (NTUs) is possible, or +/- 10% if > 10 NTUs

Turbidity is more susceptible to influence from poor well construction or inadequate well development than the other parameters. Therefore, if turbidity is difficult to stabilize or exceeds 100 NTUs, the well may need to be redeveloped or may be improperly constructed. A pH value exceeding 8, along with high turbidity, typically indicate that grout contamination is present in the water column/screened interval.

7.3.5 Purge the monitoring well following the SSWP-specific procedures to meet the criteria for ground water sample collection.

7.3.6 When collecting ground water screening samples using a direct push drilling unit, the ground water sampling device should be purged to lower sample turbidity and help ensure that the ground water screening sampling is representative of the depth from which it is collected. Purging requirements will vary based on site conditions and project DQOs (refer to the SSWP).

7.3.7 If the well goes dry before purging criteria are met, allow the well to recover sufficiently to collect the ground water sample as soon as possible but within 24 hours.

7.4 Ground Water Sample Collection

7.4.1 Use the purging device to collect the ground water sample, i.e., don't remove the purging equipment (e.g., a bladder pump) from the well and sample with another device (e.g., a bailer) unless it is absolutely necessary in order to collect the sample.

7.4.2 Fill ground water sample containers slowly and carefully. Overfilling will dilute chemical preservatives. Fill VOC samples at a rate of 100 ml/min or less to minimize volatilization.

7.4.3 If using a volumetric sampling technique, purging to dryness or no-purge sampling, collect chemical constituents in the following order: VOCs, SVOCs, other extractable organics (pesticides/herbicides/PCBs), total metals, dissolved metals, and other inorganic constituents.

7.4.4 If using the low-flow technique, sample containers for constituents other than VOCs may be filled first (in no particular order) at a flow rate of 500

ml/min or less, followed by filtered samples and VOCs (last). Reduce the flow rate to 100 ml/min or less for VOCs.

- 7.5 Decontaminate ground water purging and sampling equipment after each use in accordance with FSOP 1.6, Sampling Equipment Decontamination.
- 7.6 Dispose of investigation-derived waste (purge water and used PPE, disposable sampling equipment and supplies) in accordance with FSOP 1.7, Investigation Derived Wastes.

8.0 Data and Records Management

Refer to FSOP 1.3, Field Documentation. At a minimum, document monitoring and purging data on field ground water sampling forms or in a field logbook, and document sample collection data on a chain-of-custody (COC) form. Calibration records for water quality monitoring equipment should also be retained with site-specific purging data and COC forms.

9.0 Quality Assurance and Quality Control

- 9.1 Ground water quality assurance/quality control (QA\QC) samples should include duplicate samples and equipment blanks (if using non-dedicated, non-disposable equipment) at a minimum rate of 1 per 10 ground water samples. A trip blank should be included in every sample cooler with VOC samples. Field blanks should be collected as needed or as specified by the SSWP. Refer to the SSWP for site-specific QA/QC sample requirements.
- 9.2 Water quality monitoring instruments used to evaluate ground water stabilization parameters should be properly maintained and calibrated before each ground water sampling event per the manufacturer's instructions. During multiple-day sampling events water quality monitoring equipment should be calibrated at the beginning of each day.

10.0 Attachments

DERR Monitoring Well Sampling Log Sheet

DERR Residential Water Supply Well Sampling Log Sheet

11.0 References

FSOP 1.1, Initial Site Entry

FSOP 1.3, Field Documentation

FSOP 1.6, Sampling Equipment Decontamination

FSOP 1.7, Investigation Derived Wastes

FSOP 2.2.1, Well Development

FSOP 2.2.2, Ground Water Level Measurement

FSOP 2.2.3, Detection and Sampling of Nonaqueous Phase Liquids in Monitoring Wells

FSOP 2.2.5, Ground Water Sampling with an Inertial Lift (Check Valve) Pump

FSOP 2.2.6, Low-Flow (Low-Stress) Ground Water Sampling

FSOP 2.2.7, Ground Water Sampling Using a Bailer

FSOP 2.2.8, Ground Water Sampling Using a Bladder Pump

FSOP 2.2.9, Ground Water Sampling Using a Peristaltic Pump

FSOP 2.2.10, Ground Water Sampling Using an Electric Submersible Pump

FSOP 2.2.11, Sampling Water Supply Systems

FSOP 3.1.1., Photoionization Detector

FSOP 3.1.2, Multiple Gas Detection Meter

Ohio EPA Division of Drinking and Ground Waters, 2009, Technical Guidance Manual for Ground Water Investigations (Chapter 8: Well Development, Maintenance, and Redevelopment)

Ohio EPA Division of Drinking and Ground Waters, 2020, Technical Guidance Manual for Ground Water Investigations (Chapter 10: Ground Water Sampling)

U.S. EPA (D. Yeskis and B. Zavala), May 2002, Ground Water Sampling Guidelines for Superfund and RCRA Project Managers (Ground Water Forum Issue Paper): Office of Solid Waste and Emergency Response, EPA 542-S-02-001

Low-Flow Ground Water Sampling

FSOP 2.2.6, August 19, 2020

Ohio EPA Division of Environmental Response and Revitalization

1.0 Scope and Applicability

- 1.1 Low-flow ground water sampling is designed to collect ground water samples under minimal drawdown (low-stress) conditions. This technique minimizes vertical gradients and turbulence within the well and surrounding formation, thereby reducing undesired sampling-related changes to in-situ ground water quality.
- 1.2 Low-flow sampling assumes that under low-flow purging conditions, ground water passes continuously through a well's screened interval and does not mix with the water above the screen. The well is pumped at a rate much lower than the saturated zone yield so that drawdown is minimized and stagnant water in the casing above the screened interval remains relatively undisturbed. Fresh ground water enters the pump intake at a low velocity that minimizes turbulence in the screened interval.
- 1.3 In addition to effectively facilitating the collection of a representative ground water sample, low-flow sampling significantly reduces the volume of purge water generated compared to other ground water sampling techniques.
- 1.4 Because low-flow sampling minimizes sample volatilization and turbidity compared to other ground water sampling techniques, it is recommended for collecting ground water samples for regulatory compliance, risk assessment or modeling, especially volatile organic compound (VOC) and metal samples.
- 1.5 All ground water sampling techniques and associated procedures should be consistent with Ohio EPA's [Technical Guidance Manual \(TGM\) for Hydrogeologic Investigations and Ground Water Monitoring](#), specifically [Chapter 10, Ground Water Sampling](#). In addition, U.S. EPA 2002 (Yeskis and Zavala) provides ground water sampling guidance for RCRA and CERCLA sites. The site-specific work plan (SSWP) will provide project objectives and data quality objectives (DQOs). In the event there appears to be inconsistency between the TGM and project objectives or DQOs, please contact the DERR SIFU manager and DERR site coordinator for clarification.
- 1.6 Ohio EPA's TGM recommends that low-flow sampling be performed using a bladder pump or variable-speed electric submersible pump. Depending on SSWP project objectives and DQOs, a peristaltic pump may also be used for low-flow sampling.
- 1.7 Low-flow sampling purging rates typically vary between 100 and 500 ml/min.

2.0 Definitions

Low-flow purging is also referred to as low-stress purging, low-impact purging, minimal drawdown purging, or Micropurging®.

3.0 Health and Safety Considerations

- 3.1 Always review the site-specific health and safety plan (HASP) for site-specific hazards before performing work.
- 3.2 Refer to FSOP 2.2.4, Ground Water Sampling (General Practices) for general ground water sampling and health and safety considerations.
- 3.3 When sampling with a bladder pump and using compressed nitrogen or carbon dioxide gas, properly secure compressed gas cylinders when transporting, using or storing them.
- 3.4 When carrying a 12-volt battery, lift the battery properly. Bend your hips and knees to squat down, grasp the battery, and while keeping it close to your body, straighten your legs to lift it. Do not lift the battery by bending forward, which may cause back injury.

4.0 Procedure Cautions

- 4.1 Refer to FSOP 2.2.4, Ground Water Sampling (General Practices) for general ground water sampling procedure cautions.
- 4.2 If NAPL is encountered in a monitoring well, do not perform ground water sampling. Immediately notify the DERR-SIFU manager and DERR site coordinator.
- 4.3 Low-flow sampling should not be performed using single-speed pumps. Use of a ball or gate valve with a single-speed pump to lower the flow rate is not acceptable, because the valve will cause turbulence in the sample discharge line.
- 4.4 Low-flow sampling cannot be performed using bailers.
- 4.5 Accurately measuring the static water level before beginning the low-flow sampling process is critical for evaluating water level drawdown during sampling.
- 4.6 Avoid drawing the water level into the screened interval during low-flow purging and sampling (if the static water level is above the screened interval). If this happens, the ground water sample will need to be collected using the volumetric (well volume) technique.

- 4.7 Low flow ground water samples should not be collected until drawdown has stabilized and water quality indicator parameters have stabilized.
- 4.8 VOC sample vials should never be filled at flow rates exceeding 100 ml/min.

5.0 Personnel Qualifications

Ohio EPA personnel working at sites that fall under the scope of OSHA's hazardous waste operations and emergency response standard (29 CFR 1910.120) must meet the training requirements described in that standard.

6.0 Equipment and Supplies

- 6.1 Low-flow pump assembly, including control box and power supply or compressed nitrogen or carbon dioxide
- 6.2 Water quality meters and/or flow-through cell with data sonde to measure water quality stabilization parameters including pH, specific conductivity, temperature, dissolved oxygen (DO), oxidation reduction potential (ORP) and turbidity
- 6.3 Water level indicator
- 6.4 Stopwatch or timer (for measuring flow rate)
- 6.5 Graduated cylinder (for measuring flow rate)
- 6.6 Disposable tubing
- 6.7 Well construction information (total depth of well, depth to screened interval)
- 6.8 Other ground water sampling equipment and supplies as needed per FSOP 2.2.4, Ground Water Sampling (General Practices)

7.0 Procedures

- 7.1 If required by the SSWP or HASP, or if concerns exist regarding potentially toxic or explosive atmospheres within the well, monitor the breathing zone above the open well casing and the well casing atmosphere with a photoionization detector, multiple gas detection meter (with lower explosive limit/oxygen detection capabilities) or other required instrument and follow the breathing zone and well casing monitoring procedures included in FSOP 2.2.4, Ground Water Sampling (General Practices).
- 7.2 Before installing the pump, measure the static water level in accordance with FSOP 2.2.2, Ground Water Level Measurement.
- 7.3 Slowly and carefully install the pump in a manner that minimizes disturbance to the water column in the well. The pump should be installed in the approximate center of the screened interval. Avoid placing the pump at the bottom of the well to avoid increasing turbidity.
- 7.4 Ensure that the flow-through cell and/or water quality meters have been calibrated and are set up and ready for use.

- 7.5 Start the pump at the lowest flow rate possible and measure the flow rate in a graduated cylinder (or similar device). The purge rate will depend on the well size (diameter) and yield. Typically, the purge rate will be between 100 and 500 ml/min for a two-inch inside diameter (ID) monitoring well. The purge rate for a smaller diameter well (e.g., 0.75-inch ID) may be lower and the purge rate for a larger diameter well (e.g., 4-inch ID) may be higher.
- 7.6 Monitor the water level drawdown in the well. If continuous drawdown is occurring, reduce the pumping rate until equilibrium is achieved, i.e., the water level stabilizes with the least amount of drawdown (as compared to pre-pumping static water level).
- 7.7 If the static water level *was initially above the screened interval* and drawdown into the screened interval cannot be avoided (despite efforts to lower the pumping rate), perform volumetric sampling by purging at least three well volumes before collecting the sample. Do not exceed a purge rate of 500 ml/min. Measure stabilization parameters as required by the SSWP.
- 7.8 While monitoring the water level drawdown as described above, measure and record stabilization (water quality) parameters using the flow-through cell and/or water quality meters. The SSWP will provide specific stabilization parameters, however, at least three stabilization parameters should be measured, and two of the parameters should always include specific conductance and either DO or ORP.
- 7.9 The time interval between successive stabilization parameter measurements should always be long enough to allow one equipment volume (pump + discharge line + flow through cell) to completely be purged from the well. Generally, a time three to five minutes is acceptable. If the pumping rate is very low (e.g., 80 ml/min), the time needed between stabilization parameter measurements may need to be longer (e.g., 5 to 12 minutes).
- 7.10 Continue low-flow purging until the water level drawdown and associated parameters have stabilized. Stabilization parameters are considered stable upon meeting the following criteria for at least three consecutive measurements:

Stabilization Parameters	Criteria (<u>for at least three consecutive measurements</u>)
Temperature	+/- 0.5° C
pH	+/- 0.2 standard units (S.U.)
Specific Conductance	+/- 3%
Oxidation-Reduction Potential	+/- 20 millivolts (mV)
Dissolved Oxygen	+/- 0.3 mg/L
Turbidity	< 10 nephelometric turbidity units (NTUs) is possible, or +/- 10% if > 10 NTUs

If stabilization cannot be achieved through low-flow sampling based on SSWP DQOs and other criteria, perform volumetric sampling by purging at least three well volumes before collecting the sample. Avoid drawing the water level into the screen if possible, and do not exceed a purge rate of 500 ml/min.

- 7.11 After purging is completed, collect and handle samples following the procedures outlined in FSOP 2.2.4, Ground Water Sampling (General Practices) and FSOP 1.5, Sample Custody and Sampling. Disconnect the sample tubing from the flow-through cell prior to sample collection (*i.e.*, do not collect samples directly from the flow-through cell).
- 7.12 Collect the ground water sample by filling containers for constituents other than VOCs first (in no particular order) at a flow rate of 500 ml/min or less, followed by filtered samples (if specified by the SSWP) and VOCs (last). Reduce the flow rate to 100 ml/min or less for VOCs. If elevated turbidity is an issue, samples for metals may be collected last in an effort to minimize sample turbidity.
- 7.13 Decontaminate sampling equipment between each sampling location in accordance with FSOP 1.6, Sampling Equipment Decontamination. Do not reuse disposable tubing between sampling locations.
- 7.14 Dispose of discharge tubing and other investigation derived waste in accordance with FSOP 1.7 Investigation Derived Wastes.

8.0 Data Records and Management

Refer to FSOP 1.3, Field Documentation.

9.0 Quality Assurance and Quality Control

Refer to the SSWP and FSOP 2.2.4, Ground Water Sampling (General Practices)

10.0 Attachments

None

11.0 References

FSOP 1.3, Field Documentation.

FSOP 1.5, Sample Custody and Sampling

FSOP 1.6, Sampling Equipment Decontamination

FSOP 1.7, Investigation Derived Wastes

FSOP 2.2.2, Ground Water Level Measurement

FSOP 2.2.4, Ground Water Sampling (General Practices)

Ohio EPA Division of Drinking and Ground Waters, 2020, Technical Guidance Manual for Ground Water Investigations (Chapter 10: Ground Water Sampling)

U.S. EPA (D. Yeskis and B. Zavala), May 2002, Ground Water Sampling Guidelines for Superfund and RCRA Project Managers (Ground Water Forum Issue Paper): Office of Solid Waste and Emergency Response, EPA 542-S-02-001

Ground Water Sampling Using a Bladder Pump

FSOP 2.2.8 (December 3, 2020)

Ohio EPA Division of Environmental Response and Revitalization

1.0 Scope and Applicability

- 1.1 A bladder pump consists of a flexible bladder inside a rigid housing with check valves at the top and bottom. Water enters the bladder through a check valve and is lifted (squeezed) to the surface through a discharge line when air or inert gas (e.g., carbon dioxide) pressure is applied through an air line to the space between the inside of the housing and the outside of the bladder. An air compressor or compressed air/gas tank and regulator cycle the pressure on and off, allowing water to continuously enter the bladder and be pumped to the ground surface. The bladder chamber does not allow the ground water sample to contact the compressed air or gas. The check valves prevent backwashing from the discharge line and bladder. Flow can be readily controlled and low flow rates of 100 ml/min or less are easy to maintain.
- 1.2 Depending on project data quality objectives (DQOs), Ohio EPA recommends the use of polyethylene or Teflon® bladders and Teflon®/stainless steel bladder housings. Pump discharge line tubing should be composed of polyethylene or Teflon®. Both bladders and discharge line tubing are disposable.
- 1.3 Bladder pumps minimize ground water sample agitation, aeration and turbidity, and are generally recognized as the best overall sampling device for both organic and inorganic constituents (U.S. EPA 1992). Bladder pumps are Ohio EPA's preferred ground water sampling device, especially for the low-flow sampling technique (FSOP 2.2.6, Low-Flow Ground Water Sampling).
- 1.4 Ohio EPA's bladder pump can be used to sample wells up to 200 feet deep and wells with inside diameters as small as 0.75 inches.
- 1.5 All ground water sampling techniques and associated procedures should be consistent with Ohio EPA's [Technical Guidance Manual \(TGM\) for Hydrogeologic Investigations and Ground Water Monitoring](#), specifically [Chapter 10, Ground Water Sampling](#). In addition, U.S. EPA 2002 (Yeskis and Zavala) provides ground water sampling guidance for RCRA and CERCLA sites. The site-specific work plan (SSWP) will provide project objectives and DQOs. In the event there appears to be inconsistency between the TGM and project objectives or DQOs, please contact the DERR SIFU supervisor and DERR site coordinator for clarification.

2.0 Definitions

- 2.1 Cycles Per Minute (CPM): the number of times the process of filling and discharging the bladder occurs (cycles) over one minute
- 2.2 Discharge: the process of the bladder closing and discharging water when pressure is applied

- 2.3 Refill: the process of the bladder opening and refilling with water after the pressure is released

3.0 Health and Safety Considerations

- 3.1 Always review the site-specific health and safety plan (HASP) for site-specific hazards before performing work.
- 3.2 Refer to FSOP 2.2.4, Ground Water Sampling (General Practices) for general ground water sampling and health and safety considerations.
- 3.3 When sampling with a bladder pump and using compressed nitrogen gas or carbon dioxide, properly secure compressed gas cylinders when transporting, using or storing them.
- 3.4 When carrying a 12-volt battery, lift the battery with proper form. Bend your hips and knees to squat down, grasp the battery, and while keeping it close to your body, straighten your legs to lift it. Do not lift the battery by bending forward, which may cause back injury.
- 3.5 Be careful when operating a 12-volt power supply under wet conditions, and if using a generator for power supply ensure that it is grounded to avoid electrical shock.
- 3.6 If using a generator for power supply, handle gasoline carefully. Always wear protective gloves when handling gasoline, and store gasoline containers outside of the work area.

4.0 Procedure Cautions

- 4.1 Refer to FSOP 2.2.4, Ground Water Sampling (General Practices) for general ground water sampling procedure cautions.
- 4.2 If NAPL is encountered in a monitoring well, do not perform ground water sampling. Immediately notify the DERR-SIFU supervisor and DERR site coordinator.
- 4.3 If sampling for PFAS, ensure that the bladder pump does not contain any parts containing Teflon, including includes O-rings, bladders, and tubing.
- 4.4 Do not lower or lift the bladder pump inside a well using the discharge tubing. Instead, use a safety cord for lowering and lifting the pump. The cord should be composed of an inert material (e.g., polypropylene) that will not affect ground water quality and should be tied to the pump using a non-slip knot such as a bowline.
- 4.5 When using a bladder pump in a well containing high levels of turbidity or suspended solids, fine sediment may damage the bladder or cause the check valves to fail.

5.0 Personnel Qualifications

Ohio EPA personnel working at sites that fall under the scope of OSHA's hazardous waste operations and emergency response standard (29 CFR 1910.120) must meet the training requirements described in that standard.

6.0 Equipment and Supplies

- 6.1 Stainless steel bladder pump
- 6.2 Dual tubing (connected air line and discharge tubing)
- 6.3 Disposable bladders
- 6.4 Aluminum lock discs
- 6.5 Safety cord
- 6.6 Knife or tubing/cord cutters
- 6.5 Control box and regulator
- 6.6 Air compressor powered by 12-volt power supply and generator or compressed air/gas tanks
- 6.8 Other ground water sampling equipment and supplies as needed per FSOP 2.2.4, Ground Water Sampling (General Practices)

7.0 Procedures

- 7.1 If required by the SSWP or HASP, or if concerns exist regarding potentially toxic or explosive atmospheres within the well, monitor the breathing zone above the open well casing and the well casing atmosphere with a photoionization detector, multiple gas detection meter (with lower explosive limit/oxygen detection capabilities) or other required instrument and follow the breathing zone and well casing monitoring procedures included in FSOP 2.2.4, Ground Water Sampling (General Practices).
- 7.2 Measure the well's static water level and total depth in accordance with FSOP 2.2.2, Ground Water Level Measurement.
- 7.3 Assemble the pump per the manufacturer's instruction, taking care to prevent potential cross-contamination (e.g., assembling the pump over a clean sheet of plastic to prevent direct contact with the ground).
- 7.4 Calculate the well volume, even if low-flow sampling. If the well yield is too low to stabilize the water level for low flow sampling, the volumetric sampling technique (i.e., removal of three well volumes) will need to be used.
- 7.5 Using the safety cord, slowly and carefully install the pump in a manner that minimizes disturbance to the water column in the well. The pump should be installed in the approximate center of the screened interval. Avoid placing the pump at the bottom of the well to avoid increasing turbidity.

- 7.6 When low flow sampling, measure the static water level with the pump in the well. Monitor the static water level during sampling to ensure that drawdown is minimized. Follow other low-flow sampling procedures as described in FSOP 2.2.6, Low-Flow Ground Water Sampling.
- 7.7 Bladder pumps operate by alternating between refill and discharge cycles, which are measured in cycles per minute (CPM). Each round of refill and discharge is one cycle. Adjust the CPM control to increase or decrease the pumping or discharge rate. One CPM pressurizes for a longer time and should be used on deeper or lower yielding wells, while 4 to 6 CPM may be used on shallow or higher yielding wells.
- 7.8 The discharge rate may be optimized by adjusting the refill and discharge cycle lengths (measured in seconds on the control box readout).
- 7.9 The volume of water purged in one discharge cycle multiplied by the CPM equals the pumping rate (*e.g.*, 75 ml/cycle x 4 CPM = 300 ml/min). Measure the volume being discharged per cycle at the start of purging and periodically afterwards.
- 7.10 Increase the refill time or reduce the pressure to reduce the pumping rate.
- 7.11 Refer to the pump's manual as needed for operating instructions.
- 7.12 After purging criteria have been met, collect ground water samples in accordance with FSOP 2.2.4, Ground Water Sampling (General Practices). Handle ground water samples in accordance with FSOP 1.5, Sample Custody and Handling.
- 7.13 Decontaminate pump between sampling locations as appropriate in accordance with FSOP 1.6, Sampling Equipment Decontamination. If using a disposable bladder replace after each use.
- 7.14 Dispose of investigation derived waste in accordance with FSOP 1.7, Investigation Derived Wastes.

8.0 Data and Records Management

Refer to FSOP 1.3, Field Documentation.

9.0 Quality Assurance and Quality Control

Refer to the SSWP and FSOP 2.2.4, Ground Water Sampling (General Practices).

10.0 Attachments

None

11.0 References

FSOP 1.3, Field Documentation.

FSOP 1.5, Sample Custody and Sampling

FSOP 1.6, Sampling Equipment Decontamination

FSOP 1.7, Investigation Derived Wastes

FSOP 2.2.2, Ground Water Level Measurement

FSOP 2.2.4, Ground Water Sampling (General Practices)

FSOP 2.2.6, Low-Flow Ground Water Sampling

Ohio EPA, 2020, Technical Guidance Manual for Hydrogeologic Investigations and Ground Water Monitoring, Chapter 10, Ground Water Sampling: Ohio EPA Division of Drinking and Ground Waters

U.S. EPA (D. Yeskis and B. Zavala), May 2002, Ground Water Sampling Guidelines for Superfund and RCRA Project Managers (Ground Water Forum Issue Paper): Office of Solid Waste and Emergency Response, EPA 542-S-02-001

U.S. EPA, November 1992, RCRA Ground -Water Monitoring: Draft Technical Guidance: Office of Solid Waste

Ground Water Sampling Using a Peristaltic Pump

FSOP 2.2.9 (December 10, 2020)

Ohio EPA Division of Environmental Response and Revitalization

1.0 Scope and Applicability

- 1.1 Peristaltic pumps operate by creating a vacuum in the pump discharge line which draws ground water upwards to the ground surface. The vacuum is created by a series of rotating cams or rollers that compress and relax a flexible discharge line. Air or ground water in front of the rollers is pushed forward through the discharge line, and the portion of the discharge line behind the rollers rebounds to create a vacuum that continuously purges ground water from the well. Typically, these pumps are powered using an internal rechargeable 12-volt battery.
- 1.2 Limitations of peristaltic pumps for ground water sampling include the following:
 - 1.2.1 Because the peristaltic pumps operate by creating a vacuum, these devices can only be used to purge ground water from depths of approximately 25 feet or less below ground surface (bgs) (the vacuum limit).
 - 1.2.2 The application of a vacuum (negative pressure) to groundwater may promote an unacceptable amount of degassing and associated changes in ground water chemistry (see TGM Chapter 10). However, peristaltic pumps may be used for the collection of ground water compliance samples [FSOP 2.2.4, Ground Water Sampling (General Practices)] for volatile organic compounds (VOCs), semi-volatile organic compounds (SVOCs), pH, oxidation-reduction potential, dissolved metals, dissolved gasses or other vacuum-sensitive constituents depending on the site-specific work plan (SSWP) project objectives and data quality objectives (DQOs). If use of the peristaltic pump is not supported by the SSWP objectives or DQOs, then another pump (e.g., a bladder pump) should be considered. Peristaltic pumps -are also suitable for collecting ground water screening samples or compliance samples for constituents that are not vacuum sensitive (e.g., pesticides/herbicides, PCBs, nitrate, chloride, sulfate etc.)
 - 1.2.3 Peristaltic pumps are small and are not recommended for purging large volumes of ground water.
- 1.3 Peristaltic pumps offer the following advantages:
 - 1.3.1 Peristaltic pumps are easily portable and relatively simple to operate compared to other ground water sampling devices.
 - 1.3.2 The only pump components that contact ground water are the disposable discharge line and pump-head tubing, so minimal equipment decontamination is needed. No moving pump parts need to be decontaminated.

- 1.3.3 Sampler exposure to contaminated ground water is reduced compared to other ground water sampling techniques.
- 1.3.4 Peristaltic pumps may be used to sample wells with inside diameters as small as 0.5 inches.
- 1.3.5 Peristaltic pumps may be used to perform low-flow ground water sampling at very low rates, *i.e.*, < 100 ml/min (FSOP 2.2.6, Low-Flow Ground Water Sampling).
- 1.4 All ground water sampling techniques and associated procedures should be consistent with Ohio EPA's [Technical Guidance Manual \(TGM\) for Hydrogeologic Investigations and Ground Water Monitoring](#), specifically [Chapter 10, Ground Water Sampling](#). In addition, U.S. EPA 2002 (Yeskis and Zavala) provides ground water sampling guidance for RCRA and CERCLA sites. The SSWP will provide project objectives and DQOs. In the event there appears to be inconsistency between the TGM and project objectives or DQOs, please contact the DERR SIFU manager and DERR site coordinator for clarification.

2.0 Definitions

None

3.0 Health and Safety Considerations

- 3.1 Always review the site-specific health and safety plan (HASP) for site-specific hazards before performing work.
- 3.2 Refer to FSOP 2.2.4, Ground Water Sampling (General Practices) for general ground water sampling and health and safety considerations.
- 3.3 If the pump does not include an internal rechargeable 12-volt battery or additional battery charge is needed, an external 12-volt battery may be needed as a power source. In that case, be aware of the following health and safety considerations:
 - 3.3.1 When carrying a 12-volt battery, lift the battery properly. Bend your hips and knees to squat down, grasp the battery, and while keeping it close to your body, straighten your legs to lift it. Do not lift the battery by bending forward, which may cause back injury.
 - 3.3.2 Be careful when operating a 12-volt power supply under wet conditions.
 - 3.3.3 If using a generator for power supply with a 12-volt adaptor, ensure that it is grounded to avoid electrical shock. Handle gasoline carefully. Always wear protective gloves when handling gasoline, and store gasoline containers outside of the work area.

4.0 Procedure Cautions

- 4.1 Refer to FSOP 2.2.4, Ground Water Sampling (General Practices) for general ground water sampling procedure cautions.
- 4.2 If NAPL is encountered in a monitoring well, do not perform ground water sampling. Immediately notify the DERR-SIFU manager and DERR site coordinator.
- 4.3 If the pump does not have an internal rechargeable battery, a portable 12-volt battery or 12-volt power adapters will be needed to power the pump.
- 4.4 Discharge line and pump-head tubing used with the peristaltic pump should not adversely affect ground water quality. For discharge line, Ohio EPA recommends the use of fluorocarbon polymer (Teflon[®]), polyethylene or similarly inert materials.

5.0 Personnel Qualifications

Ohio EPA personnel working at sites that fall under the scope of OSHA's hazardous waste operations and emergency response standard (29 CFR 1910.120) must meet the training requirements described in that standard.

6.0 Equipment and Supplies

- 6.1 Peristaltic pump
- 6.2 12-volt battery or another power source (will need a 12-volt adaptor)
- 6.3 Appropriate diameter flexible tubing for pump head (cams/rollers)
- 6.4 Discharge line tubing (must connect to flexible pump head tubing)
- 6.5 Knife or tubing cutters
- 6.6 Other ground water sampling equipment and supplies as needed per FSOP 2.2.4, Ground Water Sampling (General Practices).

7.0 Procedures

- 7.1 If required by the SSWP or HASP, or if concerns exist regarding potentially toxic or explosive atmospheres within the well, monitor the breathing zone above the open well casing and the well casing atmosphere with a photoionization detector, multiple gas detection meter (with lower explosive limit/oxygen detection capabilities) or other required instrument and follow the breathing zone and well casing monitoring procedures included in FSOP 2.2.4, Ground Water Sampling (General Practices).
- 7.2 Measure the well's static water level and total depth in accordance with FSOP 2.2.2, Ground Water Level Measurement.

- 7.3 Place the pump near the well, connect the power source (if external) and install the flexible tubing and discharge line. The end of the discharge line should extend to the approximate center of the well's screened interval. Take care to prevent potential cross contamination of the discharge tubing. Avoid lowering the discharge tubing to the bottom of the well if possible, to avoid increased sample turbidity.
 - 7.4 Calculate the well volume, even if low-flow sampling. If the well yield is too low to stabilize the water level for low flow sampling, the volumetric sampling technique will need to be used.
 - 7.5 When low flow sampling, measure the static water level with the pump in the well. Monitor the static water level during sampling to ensure that drawdown is minimized. If low flow sampling. Follow other low-flow sampling procedures as described in FSOP 2.2.6, Low-Flow Ground Water Sampling.
 - 7.6 Adjust the pump speed control to increase or reduce the pumping rate to stabilize the water column drawdown. Refer to the pump's manual as needed for operating instructions.
 - 7.7 Peristaltic pumps may be used in certain scenarios (*i.e.*, see the TGM (Chapter 10, Ground Water Sampling) and site-specific work plans) for the collection of VOC ground water samples for regulatory compliance, risk assessment or modeling.
 - 7.8 After purging criteria have been met, collect ground water samples in accordance with FSOP 2.2.4, Ground Water Sampling (General Practices). Handle ground water samples in accordance with FSOP 1.5, Sample Custody and Handling.
 - 7.9 Replace the disposable discharge line and flexible pump-head tubing between each sampling location. No decontamination is necessary.
 - 7.10 Dispose of investigation derived waste in accordance with FSOP 1.7, Investigation Derived Wastes.
- 8.0 Data and Records Management**
Refer to FSOP 1.3, Field Documentation.
- 9.0 Quality Assurance and Quality Control**
Refer to the SSWP and FSOP 2.2.4, Ground Water Sampling (General Practices).
- 10.0 Attachments**
None
- 11.0 References**

FSOP 1.3, Field Documentation.

FSOP 1.5, Sample Custody and Sampling

FSOP 1.7, Investigation Derived Wastes

FSOP 2.2.2, Ground Water Level Measurement

FSOP 2.2.4, Ground Water Sampling (General Practices)

FSOP 2.2.6, Low-Flow Ground Water Sampling

Ohio EPA, October 2020, Technical Guidance Manual for Hydrogeologic Investigations and Ground Water Monitoring, Chapter 10, Ground Water Sampling: Ohio EPA Division of Drinking and Ground Waters

U.S. EPA (D. Yeskis and B. Zavala), May 2002, Ground Water Sampling Guidelines for Superfund and RCRA Project Managers (Ground Water Forum Issue Paper): Office of Solid Waste and Emergency Response, EPA 542-S-02-001

Photoionization Detector

FSOP 3.1.1 (January 27, 2021)

Ohio EPA Division of Environmental Response and Revitalization

1.0 Scope and Applicability

The photoionization detector (PID) is a portable instrument used to detect the real-time presence and relative concentration of certain ionizable compounds in gaseous or vapor states. This instrument is typically used for both health and safety monitoring of the work area breathing zone and for the screening of environmental samples. Other uses may include screening of soil gas probes or leak detection (e.g., tanks, vessels, process lines). Consult FSOP 1.1, Initial Site Entry and FSOP 2.1.4, Sample Headspace Screening prior to using a PID for health and safety monitoring or sample headspace screening procedures, respectively.

2.0 Definitions

Not applicable

3.0 Health and Safety Considerations

3.1 Hazardous vapors or explosive gases may be present in concentrations requiring use of personal protective equipment (PPE) such as respiratory protection (Table 1, FSOP 1.1, Initial Site Entry) when work area breathing zone air conditions need to be monitored. Only personnel cleared to wear respiratory protection can enter the work area breathing zone if respiratory protection is required.

3.2 Prior to use in potentially flammable atmospheres, consult the instrument manual to determine if the PID is intrinsically safe.

3.3 PIDs only measure the relative concentration of molecules in gases or vapors that are ionizable (*i.e.*, those with an ionization potential (IP) less than that of the ionization energy (IE) of the instrument's ultraviolet lamp). Refer to paragraph 3.3 below for additional information. PIDs may not detect the presence of toxic or explosive gases or vapors with relatively high IPs, including carbon monoxide, chlorine, hydrogen, hydrogen cyanide, hydrogen sulfide or methane. PIDs do not detect or measure the concentration of atmospheric oxygen or the presence of explosive atmospheres. Be sure to use the correct instrument(s) for health and safety monitoring. (Refer to FSOP 1.1, Initial Site Entry.)

3.4 Many instruments are equipped with audio and visual alarms that may be set at threshold limits for the gas or condition of concern. Default alarm levels are generally set by the manufacturer but should be set in accordance with the specified limits in the site-specific health and safety plan.

4.0 Procedure Cautions

4.1 The user should be familiar with the operation of the instrument being used. Consult the instrument manual for operating and calibration instructions specific to the instrument prior to use.

- 4.2 PID readings are not compound-specific. The instrument must be calibrated using a relatively non-toxic gas such as isobutylene and zeroed to a known clean or background air source. Readings are relative to the calibrant gas, and although the instruments display “ppm” or parts per million readings, the readings are actually ppm-calibration gas equivalents. The PID’s display concentration may be lower or higher than the actual concentration. There are correction factors that can be applied if the compound detected is known and the calibration gas is known.
- 4.3 PIDs only detect molecules that can be ionized. PIDs are equipped with ultraviolet lamps of different IEs, typically 9.8 electron volts (eV), 10.2 eV, 10.6 eV, and 11.7 eV. The IE of the lamp must be higher than the ionization potential (IP) of the compound(s) being screened. Consult the instrument manual or other reference for the ionization potential of the constituent(s) to be monitored to determine the proper lamp (or if a PID is appropriate for the proposed monitoring task).
- 4.4 PID performance may be adversely affected by temperature fluctuations, and PID readings are significantly affected by the presence of water vapor and methane due to their high IEs (> 12 eV). If using a PID in extremely wet or cold conditions, store the instrument in a relatively warm, dry location such as the front seat of a field vehicle with the heater running. A flame ionization detector may be better suited for use in these conditions and generally is preferred in situations where large temperature fluctuations, very moist or humid conditions or high methane concentrations are anticipated. Elevated methane concentrations may be encountered in subsurface areas at or adjacent to solid waste landfill disposal units.
- 4.5 Excessively dusty environments may overwhelm a PID inlet filter and reduce performance by fouling the ionization chamber or lamp. Filters should be inspected and changed after use in excessively dusty environments, and the lamp or ionization chamber should be cleaned if the instrument begins exhibiting a weak response to calibration gas.
- 4.6 If used for sample headspace screening, never allow the instrument probe to draw in liquid or solid material from a sample container, which may damage the instrument.
- 4.7 PIDs should be calibrated before each use and at any time the proper performance of the instrument appears to be questionable.
- 4.8 Always use a regulator with an appropriate flow rate to calibrate a PID. Information on calibration and regulator flow rate should be included in the operator’s manual.
- 4.9 Never use a source of highly concentrated organic vapors to check whether a PID is responding properly (e.g., never insert a PID probe into the fill port of a vehicle fuel tank, as doing so could damage the instrument).

- 4.10 Take care when using a PID to screen atmospheres with highly concentrated organic vapors (e.g., opening of a drum containing solvent- or petroleum-contaminated soil). Screening in this manner may contaminate the instrument's lamp or filter to the point that the PID must be serviced or removed from the area of elevated vapor concentrations until it can equilibrate or may otherwise damage the instrument.
- 4.11 PIDs should be cleaned, inspected, and internally calibrated annually by a service center authorized by the instrument manufacturer.
- 4.12 Always transport the instrument in a protective case or secure the instrument during transport.

5.0 Personnel Qualifications

Ohio EPA personnel working at sites that fall under the scope of OSHA's hazardous waste operations and emergency response standard (29 CFR 1910.120) must meet the training requirements described in that standard.

6.0 Equipment and Supplies

- 6.1 Calibrant gas (e.g., isobutylene)
- 6.2 Regulator for calibrant gas cylinder
- 6.3 Clean containers such as sealable plastic bags or jars with foil or film covers (if using for headspace screening)
- 6.4 Field logbook, field log sheets, or appropriate field form
- 6.5 Pens or markers
- 6.6 PPE appropriate for site-specific work activities
- 6.7 Inert tubing with "tee" connector
- 6.8 Instrument with operation manual
- 6.9 Protective case for instrument transport
- 6.10 Tedlar® bag
- 6.11 Calibration log sheet

7.0 Procedures

- 7.1 Consult the instrument manual for both general procedures and instrument-specific operating functions prior to using the instrument.
- 7.2 Make sure instrument is fully charged before use. Bring a backup battery if necessary.
- 7.3 Turn the instrument on and allow it to warm up. Some instruments will give a "ready" prompt in the instrument display when ready for use. Make sure pump is running and lamp is on. Check for warnings on instrument display during warm up. Check alarm levels to be sure they are consistent with site specific health and safety plan.

- 7.4 Calibrate the instrument according to the manufacturer's instructions with a relatively non-toxic span gas (e.g., isobutylene) before each use.
- 7.4.1 Calibrate the instrument directly from the cylinder using a flow regulator of appropriate flow rate (equal to or slightly higher than the pump capacity) or a pressure demand regulator. Use a piece of tubing to connect the regulator to the instrument probe. If the regulator flow rate is significantly higher than the pump flow, then install a "tee" fitting in the tubing to bleed of excess calibrant gas.
- 7.4.2 For an alternate calibration method, fill a clean Tedlar® bag with the calibrant gas by first connecting the cylinder to the bag with the regulator and tubing and allowing the bag to inflate after opening the valve on the bag. Next, close the valve on the bag, attach the instrument probe to the bag with a length of tubing and open the bag valve when ready to calibrate.
- 7.4.3 Record calibration data, including operator name, location, instrument make and model, date, time, calibration gas type, and result on the calibration log sheet.
- 7.5 Zero the instrument with a clean air source such as a cylinder of certified clean air, or to ambient (background or off-site) air, and ensure that the instrument is zeroed or recording background readings before use.
- 7.6 Use the instrument for health and safety monitoring or headspace screening in accordance with the site-specific health and safety plan and FSOP 1.1, Initial Site Entry and/or site-specific work plan and FSOP 2.1.4, Sample Headspace Screening as appropriate.
- 7.7 Observe and record the instrument readings as appropriate.

8.0 Data and Records Management

Refer to FSOP 1.3, Field Documentation.

9.0 Quality Assurance and Quality Control

Not applicable

10.0 Attachments

None

11.0 References

FSOP 1.1, Initial Site Entry

FSOP 1.3, Field Documentation

FSOP 2.1.4, Sample Headspace Screening

Chapter 4

Pumping and Slug Tests

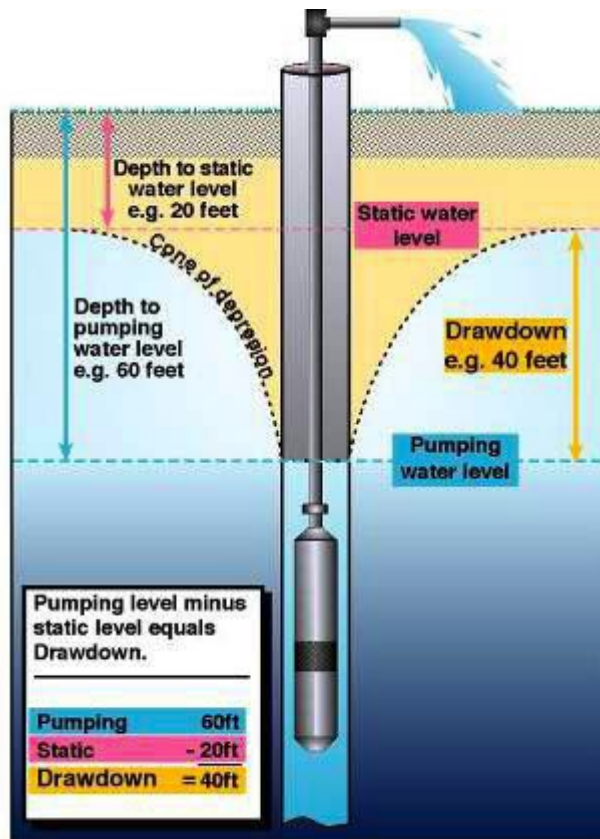

John R. Kasich, Governor
Mary Taylor, Lt. Governor
Craig W. Butler, Director

February 2018

Technical Guidance Manual for Hydrogeologic Investigations and Ground Water Monitoring

Chapter 4 Pumping and Slug Tests

February 2018

Revision 2

Ohio Environmental Protection Agency
Division of Drinking and Ground Waters
P.O. Box 1049
50 West Town Street
Columbus, Ohio 43216-1049
Phone: (614) 644-2752
epa.ohio.gov/ddagw/

Preface

This document is part of a series of chapters incorporated in Ohio EPA's *Technical Guidance Manual for Hydrogeologic Investigations and Ground Water Monitoring* (TGM), which was originally published in 1995. DDAGW now maintains this technical guidance as a series of chapters rather than as an individual manual. The chapters can be obtained at epa.ohio.gov/ddagw/gw_support.aspx

The TGM identifies technical considerations for performing hydrogeologic investigations and ground water monitoring at potential or known ground water pollution sources. The purpose is to enhance consistency within the Agency and inform the regulated community of the Agency's technical recommendations and the basis for them.

Ohio EPA utilizes **guidance** to aid regulators and the regulated community in meeting laws, rules, regulations and policy. Guidance outlines recommended practices and explains their rationale. The methods and practices described in this guidance are not intended to be the only methods and practices available to an entity for complying with a specific rule. Unless following the guidance is specifically required within a rule, the Agency cannot require an entity to follow methods recommended within the guidance. The procedures used should be tailored to the specific needs and circumstances of the individual site, project and applicable regulatory program, and should not comprise a rigid step-by-step approach utilized in all situations.

Major Changes from April 2007 TGM

Ohio EPA's *Technical Guidance Manual for Hydrogeologic Investigations and Ground Water Monitoring* (TGM) was first finalized in 1995. Chapter 4 (Pumping and Slug Tests) was revised in December 2006. This is the second revision to the chapter.

Section numbers were added to make the document easier to read.

References were updated, in particular, the references to ASTM standards and U.S. EPA guidance documents.

Additional information has been added on:

- Definition and clarification of “well skin effects” in slug testing
- Addition of guidance regarding use of appropriate well construction parameters in slug testing, including use of “effective” well construction parameters
- Terminology changed throughout document to make concepts flow better and easier to understand

Table of Contents

Preface.....	ii
Table of Contents.....	iv
1.0 Slug Tests.....	7
1.1 Design and Performance of Slug Test.....	8
1.1.1 Design of Well.....	8
1.1.2 Number of Tests.....	8
1.1.3 Test Performance and Data Collection.....	8
1.2 Modified Slug Tests.....	8
1.2.1 Packer Tests within a Stable Borehole.....	9
1.2.2 Pressure Tests.....	9
1.2.3 Vacuum Tests.....	9
1.3 Analysis of Slug Test Data.....	9
1.4 Presentation of Slug Test Data.....	10
2.0 Single Well Pumping Tests.....	13
2.1 Analysis and Presentation of Single Well Pumping Tests.....	13
3.0 Multiple Well Pumping Tests.....	15
3.1 Preliminary Studies.....	15
3.2 Pumping Test Design.....	16
3.2.1 Pumping Well Location.....	16
3.2.2 Pumping Well Design.....	16
3.2.3 Pumping Rate.....	16
3.2.4 Pump Selection.....	17
3.3 Observation Well Number.....	17
3.3.1 Observation Well Design.....	17
3.3.2 Observation Well Depth.....	17
3.3.3 Observation Well Location.....	18
3.4 Duration of Pumping.....	19
3.4.1 Discharge Rate Measurement.....	19
3.4.2 Discharge Measuring Devices.....	19
3.4.3 Interval of Water Level Measurements.....	20
3.5 Water Level Measurement Devices.....	21

3.6 Discharge of Pumped Water	21
3.7 Decontamination of Equipment.....	21
4.0 Correction to Drawdown Data	22
4.1 Barometric Pressure	23
4.2 Saturated Thickness.....	23
4.3 Unique Fluctuations.....	23
4.4 Partially Penetrating Wells.....	24
4.5 Noordbergum Effect.....	24
5.0 Analysis of Multiple Well Pumping Test Data	25
5.1 Presentation of Multiple Well Tests Data.....	25
5.2 Recovery Tests.....	27
6.0 References	36

Chapter 4

Pumping and Slug Tests

Slug and pumping tests are used to determine in-situ properties of water-bearing formations and define the overall hydrogeologic regime. Such tests can determine transmissivity (T), hydraulic conductivity (K), storativity (S), yield, connection between saturated zones, identification of boundary conditions, and the cone of influence of a pumping well in an extraction system. The hydraulic properties that can be determined are particular to the specific test method, instrumentation, knowledge of the ground water system, and conformance of site hydraulic conditions to the assumptions of the test method (ASTM 4043-96 (2004)). The selection of test method(s) depends primarily on the hydrogeology of the area being tested. Secondarily, the method is selected based on the testing conditions specified by a particular method, such as the method of causing water level changes in the ground water zone or the requirements for observing water level responses.

To ensure proper test design, it is important to define objectives and understand site hydrogeology as much as possible. Methods, instruments and operating procedures should be specified in a workplan. Test results, methods and any departures from the workplan that were necessary during implementation of the workplan should be documented in the final report.

The purpose of this chapter of the Technical Guidance Manual for Hydrogeologic Investigations and Ground Water Monitoring (TGM) is to aid in the design and performance of slug and pumping tests, provide recommended quality assurance and quality control (QA/QC) procedures, and present a standardized approach to the presentation of the resulting data. This chapter covers various types of tests, including single well and multiple well. It includes a discussion of the advantages and disadvantages of the various tests and the minimum criteria that should be considered prior to, during and after implementation of the tests. The recommendations presented here are a subset of the larger hydrogeologic characterization process that is implemented when characterizing a site. The additional investigative tools necessary to adequately characterize a site, as well as recommendations for their use, are contained in other chapters of the TGM. This chapter does not cover pumping tests conducted for the purpose of determining whether a ground water zone can produce a sufficient amount of yield for water supply purposes.

1.0 Slug Tests

Slug tests are generally conducted to determine the horizontal K of a ground water zone. A slug test involves the abrupt removal, addition or displacement of a known volume of water and the subsequent monitoring of changes in water level as equilibrium conditions return. The measurements are recorded and analyzed by one or more methods. The rate of water level change is a function of the K of the formation and the geometry of the well or screened interval.

Slug tests generally are typically most useful in formations that exhibit low K, and thus may not be appropriate in fractured rock or formations with T greater than 250 m²/day (2,690 ft²/day) (Kruseman and de Ridder, 1990). However, a vacuum or slug test conducted in fractured or high T formations with a pressure transducer or an electronic data logger may produce accurate, defensible results in some instances.

Hydraulic properties determined by slug tests are representative only of the material in the immediate vicinity of the well. However, by performing a series of slug tests at discrete vertical intervals and tests in closely spaced wells, important information can be obtained about the vertical and horizontal variations of hydraulic properties for the site (Butler, 1998). It should be noted that due to the localized nature of hydraulic response, the test results might be affected by the properties of the well filter pack or “well skin effects” (for example, physical or geochemical alteration of near-well conditions resulting from drilling). Therefore, the results should be compared to known values for similar geologic media to determine if they are reasonable. Additionally, adjustments for well skin effects should be made, where appropriate (Butler, 1998).

If slug tests are used, the designer should consider the amount of displaced water, design of the well, number of tests, method and frequency of water level measurements, and the method used to analyze the data. Slug tests should be conducted in properly designed and developed wells or piezometers. If development is inadequate, the smearing of fine-grained material along the borehole wall may result in data that indicate an artificially low K. Drilling and sampling a well can cause geochemical changes that lead to similar effects on the aquifer pore spaces immediately surrounding a well. Such physical or geochemical alterations of near-well conditions from drilling and sampling are termed “well skin effects” (Butler, 1998) and could lead to poor estimation of contaminant migration potential. Well skin effects result from locally increasing the K near the well by opening fractures or intergranular porosity (positive skin) or by decreasing the K (negative skin) through: a) filling voids or coating borehole walls with drilling cuttings, or b) preferential closing of voids by chemical precipitate resulting from interaction of atmosphere with the saturated zone through installation and/or sampling of the well (Butler, 1998; Sevee, 2006).

Drilling methods, well design and installation, and well development are covered in TGM Chapters 6, 7 and 8, respectively. The design, analytical methods, and information that should be reported to document that the tests were conducted properly are discussed briefly below. Detailed practical guidelines for the design, performance and analysis of slug tests are provided by Butler (1998). Additional information can also be found in Black (1978), Chirlin (1990), Dawson and Istok (1991), Ferris et al. (1962), Kruseman and de Ridder (1990), and Lohman (1972), Batu (1988), and ASTM standards.

For some programs, workplans may need to be submitted prior to conducting tests to ensure that results will be relevant to regulatory and program goals. If needed, the workplan should discuss the components listed below for the design and performance of the slug tests and the method of analysis.

1.1 Design and Performance of Slug Test

1.1.1 Design of Well

Well depth, length and diameter of screen, screen slot size, and distribution of the filter pack should be known and based on site-specific boring information for a well to be used as a valid observation point. For example, equations used in data analysis incorporate the radii of the well and borehole. The nature of the materials comprising the screened interval (for example, thickness, grain size, and porosity of the filter pack) also must be known. Recommendations for monitoring well construction are provided in TGM Chapter 7.

1.1.2 Number of Tests

Properties determined from slug tests at a single location are not very useful for site characterization unless they are compared with data from tests in other wells installed in the same zone at or near the site. When conducted in large number, slug tests are valuable for determining subsurface heterogeneity and isotropy. The appropriate number depends on site hydrogeologic complexity.

1.1.3 Test Performance and Data Collection

Data collection should include establishment of water level trends prior to and following the application of the slug. Pre-test measurements should be made until any changes have stabilized and should be taken for a period of time, at least as long as the expected recovery period. Water level measurements in low-permeability zones may be taken with manual devices. Automatic data loggers should be used for tests of high-permeability zones. Slug tests should be continued until at least 85 percent recovery of the initial pretest measurement is obtained (U.S. EPA, 1986).

Whenever possible, water should be removed by either bailing or it should be displaced by submerging a solid body. According to Black (1978), an addition of water invariably arrives as an initial direct pulse followed by a subsequent charge that runs down the sides of a well. This may result in a response that is not instantaneous, which may subsequently influence the data (Figure 4.1). An advantage of displacement is that it allows for collection and analysis of both slug injection and slug withdrawal data. However, in wells where the screened interval intercepts the water table slug withdrawal tests are generally much more representative than slug injection tests.

The volume of water removed or displaced should be large enough to ensure that build-up or drawdown can be measured adequately, but it should not result in significant changes in saturated zone thickness (Dawson and Istok, 1991). Kruseman and de Ridder (1990) suggest water level displacement between 10 and 50 centimeters (Kruseman and de Ridder, 1990). Field procedures for slug tests are also described in ASTM D 4044-96 (2002).

1.2 Modified Slug Tests

In addition to removal or displacement of water, a change in static water level can be accomplished by pressurizing a well with air or water or by creating a vacuum. Packers are often used to seal the zone to be tested.

1.2.1 Packer Tests within a Stable Borehole

Horizontal K for consolidated rock can be determined by a packer test conducted in a stable borehole (Sevee, 2006). A single packer system can be used when testing between a packer and the bottom of the borehole. Two packer systems can be utilized in a completed borehole at any position or interval. A packer is inflated using water or gas. Water should be injected for a given length of time to test the packed-off zone.

Figure 4.1

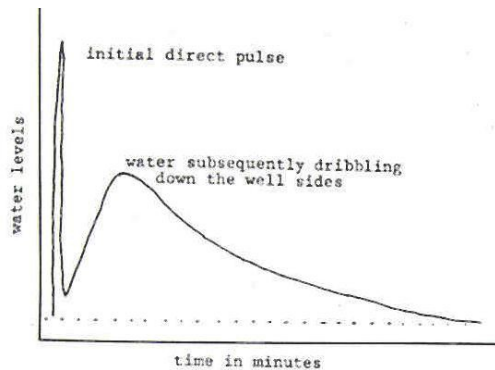

Figure 4.1. Results of a slug test with addition of water. Water arrives as an initial direct pulse followed by a subsequent charge that runs down the sides of the well (Source: Adapted from Black, 1978).

1.2.2 Pressure Tests

A pulse or a pressure test may be appropriate in formations where K can be assumed to be lower than 10^{-7} cm/sec. In a pulse test, an increment of pressure is applied into a packed zone. The decay of pressure is monitored over a period of time using pressure transducers with electronic data loggers or strip-chart recorders. The rate of decay is related to the K and S of the formation being tested. This test generally is applied in rock formations characterized by low K . Compensation must be made for well skin effects (Sevee, 2006) and packer adjustments during the test. An understanding of the presence and orientation of fractures is necessary to select an appropriate type curve to analyze test data (Sevee, 2006 and Sara, 2003). ASTM D4631-95 (2002) describes the pressure-pulse technique applied to low hydraulic conductivity bedrock.

1.2.3 Vacuum Tests

According to Orient et al. (1987), vacuum tests can be used to evaluate the K of glacial deposits and compare favorably to more conventional methods. In general, water level is raised by inducing vacuum conditions. Once it reaches the desired height and sufficient time has been allowed for the formation to return to its previous hydrostatic equilibrium, the vacuum is broken, and the recovery is monitored. The data is evaluated using the same techniques that are used to evaluate conventional slug test data.

1.3 Analysis of Slug Test Data

Mathematical methods/models for slug test data analysis are summarized in Table 4.1. Methods have been developed to deal with confined, unconfined, partial penetration and well skin effects. Calculation of K for a fully screened zone is achieved by dividing T by the entire thickness of the zone. A test of a partially penetrating well yields a T value that is only indicative of that portion of the zone that is penetrated by the well screen.

Table 4.1 Analysis Methods for Slug Tests.

General Assumptions					
<ol style="list-style-type: none"> 1) The ground water zone has an apparently infinite areal extent. 2) The zone is homogeneous and of uniform thickness over the area influenced by the test (except when noted in application column). 3) Prior to the test, the water table or piezometric surface is (nearly) horizontal over the area influenced and extends infinitely in the radial direction. 4) The head in the well is changed instantaneously at time $t_0 = 0$. 5) The inertia of the water column in the well and the linear and non-linear well losses are negligible (for example, well installation and development process are assumed to have not changed the hydraulic characteristics of the formation). 6) The well diameter is finite; hence storage in the well cannot be neglected. 7) Ground water density and viscosity are constant. 8) No phases other than water (such as gasoline) are assumed to be present in the well or ground water. 9) Ground water flow can be described by Darcy's Law. 10) Water is assumed to flow horizontally. 					
		Application			
Method	Ground Water Zone Type	Flow Condition	Can account for		Remarks
			Partial Penetration	Anisotropic	
Cooper et al. (1967) (a,b,c)	Confined	Transient	No	No	Also described in ASTM D4104-91 (1992)
Bouwer and Rice (1976) Bouwer (1989) (a,b,c)	Unconfined or leaky*	Steady state	Yes	No	Can be used to estimate the K of leaky ground water zones that receive water from the upper-semi confining layer through recharge or compression
Hvorslev (1951) (a, c)	Confined or Unconfined	Transient	Yes	Yes	Differences of 0.3X to 0.5X can be observed when comparing the K calculated from other methods In some cases, can be applied to unconfined ground water zones, Fetter (2001)
Bredehoeft and Papadopulos (1980) (c)	Confined	Transient		Yes	Low to extremely low K (for example, silts, clays, shales)
Uffink (1984) (Oscillation Test) (b)	Confined	Transient		No	

Described in: a-Dawson and Istok (1991). b- Kruseman and de Ridder (1990); c-Butler (1998)

As alluded to in “Design of Well” above, slug test analysis formulas include well construction parameter inputs that must be actual or “effective,” as applicable. For example, when artificial filter packs are more permeable than the surrounding formation, the “effective well screen radius” (for example, radius of the

nominal well screen plus filter pack) is a more representative parameter than to the nominal well screen radius alone. The representativeness of well construction parameter estimates used in analysis formulas can have a significant effect on the representativeness of analysis results. Therefore, well construction parameter values or estimates used in each analysis should be documented and defensible. Butler (1998) for example, provides criteria for defensible estimates of effective well screen radius, effective well screen length and other well construction parameters.

Test results obtained are for the geologic material immediately surrounding the well intake, which invariably has been altered to some degree by the installation process.

Computer programs are available to evaluate slug test data. Only those programs that provide analysis of the data based on graphical curve matching, rather than simply least-squares analysis, and allow for the generation of data plots should be used.

1.4 Presentation of Slug Test Data

The specifics of slug tests should be documented to demonstrate that the tests were conducted properly and that the data and interpretations are representative of site conditions. At a minimum, the following should be specified:

- The design and implementation of the test including: Well construction (for example, depth, diameter and length of screen and filter pack).
- Method to displace the water, such as:
 - Dimension and weight of slug.
 - Composition of slug.
 - Manner in which the slug will be lowered and raised from the well.
 - Use of packers, and manner in which pressure will be delivered.
 - Chemical quality of water to be added.
- Frequency and method of water level measurements.
- Number and location of tests.
- All raw data.
 - Method. Name of analytical method(s) used; computer programs used for analysis should be referenced and all assumptions and limitations should be noted. For methods that employ type curves curve matching, the following should be provided.
 - The portion of data to which type curves are fit should be indicated on the plot.
 - If an analysis method employing a family of type curves is used, all curves selected to fit the data should be described.
- All data plots. Plots of change in hydraulic head versus time should be presented for all slug-tested wells. Plots should be on an arithmetic scale, and either double-logarithmic or semi-logarithmic scale, depending on the analysis technique. Time data should be depicted along the horizontal axis, and change in head along the vertical axis. All data points should be clearly labeled and identified in a legend. If multiple tests are presented on the same plot, the labeling should be distinct to differentiate between data sets.

- Sample calculations. Equations used for calculating hydraulic properties should also be included. While calculations of the values (for example, hydraulic conductivity, estimated transmissivity) can be presented on the data plots, the values themselves should be presented in tabular format in the report for all slug tested wells, all zones tested, and each data analysis method used.
- Any field conditions or problems that may influence the results.
- An evaluation and interpretation of the data (relating it to overall site conditions). In the event that calculations are available from other multiple- or single-well tests, the report should contain a discussion addressing how the most recent calculations compare with previously obtained values.

2.0 Single Well Pumping Tests

A single well test involves pumping at a constant or variable rate and measuring changes in water levels in the pumped well during pumping and recovery. Single well pumping tests can be used to determine transmissivity, hydraulic conductivity and yield of a ground water zone. They are also conducted to determine well loss, and optimizing rate and pump setting for a multiple well test. Single well tests are often used when water level recovery is too rapid for slug tests and no observation wells or piezometers are available. Single well tests generally will not identify impermeable boundaries, recharge boundaries, or interconnection between other ground water or surface water unless these conditions exist in very close proximity to the well being tested.

A step drawdown test is a type of single well test that is often used to optimize appropriate pumping rate and depth of pump setting used in a later multiple well test (Domenico and Schwartz, 1998). This test involves pumping at a constant rate for a period of time, the rate is then increased. This process generally is repeated through a minimum of three steps. The duration of each step generally should be a minimum of 60 minutes and should be long enough such that drawdown data plotted on a semilog plot fall on a straight line. References detailing the mechanics of a step test include Kruseman and de Ridder (1990), Driscoll (1986), Dawson and Istok (1991), and Batu (1998) and Walton (1996).

The drawdown in a pumped well is influenced by well loss and well-bore storage. Well loss is responsible for drawdown being greater than expected from theoretical calculations and can be classified as linear or non-linear. Linear loss is caused by compaction and/or plugging of subsurface material during well construction and installation and head loss in the filter pack and screen. Non-linear loss includes head loss from friction within the screen and suction pipe.

Since well-bore storage is large when compared to an equal volume of formation material, it must be considered when analyzing drawdown data from single well tests (Kruseman and de Ridder, 1990). The effects of well-bore storage on early-time drawdown data can be recognized by a log-log plot of drawdown (s_w) versus time (t). Borehole storage effects exist if the early-time drawdown data plots as a unit-slope straight line (Kruseman and de Ridder, 1990). Papadopoulos and Cooper (1967) observed that the influence of well-bore storage on drawdown decreases with time (t) and becomes negligible at:

$$t = 25r_c^2 / KD$$

where:

r_c = the radius of the unscreened part of the well

K = hydraulic conductivity

D = thickness of saturated zone.

2.1 Analysis and Presentation of Single Well Pumping Tests

Table 4.2 presents several methods for analyzing drawdown data for constant discharge, variable discharge, and step-discharge single well tests. Analysis of recovery test data (residual drawdown) is valuable with a single well pumping test. Methods for analysis are straight line methods, which are the same as for conventional pumping tests. However, with single well tests, one must account for the effects of well-bore storage when evaluating recovery (Kruseman and de Ridder, 1990). Recovery data may be more reliable than data collected during the pumping phase because pumping does not influence recovery. Available methods to analyze recovery are discussed in the Multiple Well Pumping Tests section of this chapter.

Information to document that single well tests have been appropriately performed and analyzed may be similar to documentation for either slug or multiple well pumping tests.

Table 4.2 Single well pumping tests.

General Assumptions			
<ol style="list-style-type: none"> 1) The ground water zone is infinite in aerial extent. 2) The zone is homogeneous, isotropic, and of uniform thickness over the area influenced by the test. 3) Prior to pumping, the piezometric surface is horizontal, or nearly so, over the area to be influenced. 4) The well penetrates the entire ground water zone and, thus, receives water by horizontal flow. 5) The water removed from storage is discharged instantaneously with decline of head. 6) Non-linear well losses are negligible. 			
The following assumptions/conditions apply to leaky confined ground water zones.			
<ol style="list-style-type: none"> 1) The aquitard is infinite in aerial extent. 2) The aquitard is homogeneous, isotropic and of uniform thickness. 3) The water supplied by leakage from the aquitard is discharged instantaneously with decline in head. 			
Method	Application		Remarks
	Ground Water Zone Type	Flow Condition	
Papadopulos and Cooper (1967) (a & b)	Confined	Transient	Early time data does not adequately reflect zone characteristics. May be difficult to match the data curve with appropriate type curves because of similarities of curves. Constant discharge. Equations take storage capacity of well into account.
Rushton and Singh (1983) (b)	Confined	Transient	More sensitive curve fitting than Papadopulos and Cooper method. Constant discharge.
Birsoy and Summers(1980) (b)	Confined	Transient	Variable discharge (zone is pumped stepwise or is intermittently pumped at constant discharge).
Hurr-Worthington (Worthington, 1981) (b)	Confined or leaky confined	Transient	Constant discharge. Modified Theis Equation.
Jacob's Straight Line Method (b)	Confined or leaky confined	Transient	Sensitive to minor variations in discharge rate. May be able to account for partial penetration if late-time data is used. Constant discharge.
Hantush (1959b) (b)	Leaky confined/ artesian	Transient	Flow through aquitard is vertical. Variable discharge.
Jacob and Lohman (1952)(b)	Confined/ artesian	Transient	If value of the effective radius is not known then storativity cannot be determined. Variable discharge (drawdown is constant).

a-Described in Dawson and Istok (1991),

b-Described in Kruseman and de Ridder (1990)

3.0 Multiple Well Pumping Tests

A multiple well test is implemented by pumping a well continuously and measuring water level changes in both the pumped and observation wells during pumping or subsequent recovery. Properly designed and conducted multiple well tests can be used to define the overall hydrogeologic regime of the area being investigated, including T, S and/or specific yield of a zone. They also can help design municipal well fields, predict rates of ground water flow, determine interconnectivity between ground water zones, and design a remediation system.

Two basic types of multiple well pumping tests are constant discharge and variable discharge. The former is performed by pumping at a constant rate for the duration of the test, while the latter is distinguished by changes in rate. Measurements obtained from the pumping well generally are less desirable for calculating hydraulic properties because of the irregularities induced from the operation of the pump and well bore storage. Obtaining data from observation well(s) allows for characterization of the pumped zone over a larger area.

Test design and data analysis depends on the characteristics of the zone tested, the desired/required information to be evaluated and available funds. Design and analysis are summarized below. More detailed information can be found in Lohman (1972), Walton (1987), Dawson and Istok (1991) and Kruseman and de Ridder (1990).

3.1 Preliminary Studies

Pumping test methods are specific to the hydrogeology of the area being evaluated and the specific assumptions of the analytical solution of the chosen test method. Therefore, a prerequisite for selecting the most appropriate method is gathering as much information about the site as possible. Prior to testing, the following should be gathered:

- Geologic characteristics of the subsurface that may influence ground water flow.
- Type of water-bearing zone and its lateral and vertical extent.
- Depth, thickness and lateral extent of any confining beds.
- Location of recharge and discharge boundaries.
- Horizontal and vertical flow components (for example, direction, gradient).
- Location, construction and zone of completion of any existing wells in the area.
- Location and effects of any pumping wells.
- Approximate values and spatial variation of formation K, T and S.
- Seasonal ground water fluctuations and any regional trends.

This preliminary information can assist in the proper design of the test and the choice of a conceptual model. Test design also can be facilitated by preliminary conceptual modeling to predict the outcome of the test beforehand (Walton, 1987). This serves two purposes. First, it describes the ground water zone so that an appropriate data analysis method is evident. Second, it suggests deficiencies in observation well locations. Costs frequently are reduced by using existing wells (production, drinking, monitoring) rather than installing new ones. However, they need to be evaluated to determine whether they are properly constructed, located and equipped to be used for pumping and/or observation points. Single well tests should be conducted on the existing wells to determine whether they will respond to water level changes.

3.2 Pumping Test Design

As indicated, the design of a pumping test depends on the hydrogeologic environment and the purpose of the test. The designer should determine pumping well location (areal and depth) and design, pumping rate, pump selection, location and depth of observation wells, test duration, discharge rate measurements and devices, interval and method of water level measurements, and method of analyzing data.

3.2.1 Pumping Well Location

A pumping well should be located far enough away from hydraulic boundaries to permit recognition of drawdown trends before boundary conditions influence the data (Sevee, 2006). To minimize the effect of stream, river or lake bed infiltration, it should be located at a distance equal to or exceeding the ground water zone thickness from the possible boundary (Walton, 1987). However, if the intent is to induce recharge, then the pumping well should be located as close to the recharge boundary as possible (Sevee, 2006). The appropriate depth should be determined from exploratory boreholes or logs from nearby wells.

3.2.2 Pumping Well Design

The design of a pumping well depends on the hydrogeologic environment, the choice of conceptual model, and economics. Components to consider include diameter, length and depth of the screened interval, and screen slot configuration.

A general rule is to screen the well over at least 80 percent of the ground water zone thickness. This makes it possible to obtain about 90 percent or more of the maximum yield that could be obtained if the entire zone were screened, and allows horizontal flow toward the well to be assumed, which is an assumption that underlies almost all well-flow equations. Pumping wells completed in thick zones often have intake lengths less than 80 percent of the thickness. These wells are considered partially penetrating (Kruseman and de Ridder, 1990), and pumping would be expected to induce vertical flow components. As a result, corrections to the drawdown data may be necessary. Corrections are discussed later in this chapter.

The diameter of a pumping well depends on the method chosen to analyze the data and the estimated hydraulic properties. It must accommodate the pump, assure hydraulic efficiency and allow measurement of depth to water before, during and after pumping. Table 4.3 recommends casing diameters based on pumping rates; however, the final selection should be based on consultation with the pump manufacturer.

The screen slot size and filter pack material should be based on the grain size distribution of the zone being pumped (Kruseman and de Ridder, 1990). The screen should be factory slotted or perforated over no more than 40 percent of its circumference. Slots should be long and narrow or continuous. Slots produced manually are not recommended.

3.2.3 Pumping Rate

The rate(s) should be sufficient to ensure that the ground water zone is stressed and that drawdown can be measured accurately. The water table in an unconfined zone should not be lowered by more than 25 percent since it is the largest relative drawdown that can be corrected and analyzed with an analytical solution of the ground water flow equation (Dawson and Istok, 1991). The pumping rate for tests conducted in confined zones should not readily dewater the pumping well. Well efficiency and an appropriate pumping rate for a constant discharge test can be determined by conducting a step-drawdown test (See Single Well Tests).

Table 4.3 Recommended pumping well diameter for various pumping rates.

(Dawson and Istok, 1991, after Driscoll, 1986).

Pumping Rate		Diameter	
Gal/min	m ³ /day	(in)	(mm)
<100	<545	6	152
75-175	409-954	8	203
150-350	818-1,910	10	254
300-700	1,640-3,820	12	305
500-1,000	2,730-5,450	14	365
800-1,800	4,360-9,810	16	406
1,200-3,000	6,540-16,400	20	508

Other methods that may be useful to estimate an appropriate pumping rate include: 1) using an empirical formula to predict well specific capacity; and 2) predicting drawdown using analytical solutions. These methods are described by Dawson and Istok (1991). It should be noted that these techniques predict discharge rates that can be utilized to determine hydraulic parameters and should not be utilized to estimate an appropriate rate for capturing a contaminant plume.

3.2.4 Pump Selection

The pump and power supply must be capable of operating continuously at an appropriate constant discharge rate for at least the expected duration of the test. Pumps powered by electric motors produce the most constant discharge (Stallman, 1983).

3.3 Observation Well Number

The appropriate number of observation wells depends on the goals of the test, hydrogeologic complexity, the degree of accuracy needed, and the method employed to analyze the data. In general, at least three are recommended (Kruseman and de Ridder, 1990). If two or more are available, data can be analyzed by both time (x-axis) versus drawdown (y-axis) and distance (x-axis) versus drawdown (y-axis) relationships. Using both and observing how wells respond in various locations provides greater assurance that: 1) the calculated hydraulic properties are representative of the zone being pumped over a large area; and 2) any heterogeneities that may affect the flow of ground water and contaminants have been identified. In areas where several complex boundaries exist, additional wells may be needed to allow proper interpretation of the test data (Sevee, 2006).

3.3.1 Observation Well Design

In general, observation wells need to be constructed with an appropriate filter pack, screen slot size and annular seal, and must be developed properly. Practices for design and development of observation wells can be similar to those for monitoring wells (see TGM Chapters 7 and 8). The observation wells/piezometers should be of sufficient diameter to accommodate the measuring device.

3.3.2 Observation Well Depth

Fully-penetrating wells are desirable. The open portion of an observation well generally should be placed in the same horizon as the intake of the pumping well. When testing heterogeneous zones, it is recommended that an observation well be installed in each permeable layer. Additional wells should be placed in aquitards to determine leakage and interconnectivity (Kruseman and de Ridder, 1990).

3.3.3 Observation Well Location

Observation well location depends on the type of ground water zone, estimated transmissivity, duration of the test, discharge rate, length of the pumping well screen, whether the zone is stratified or fractured and anticipated boundary conditions. Placing observation wells 10 to 100 meters (33 to 328 feet) from the pumping well is generally adequate for determining hydraulic parameters. For thick or stratified, confined zones, the distance should be greater (Kruseman and de Ridder, 1990). Also, additional observation wells located outside the zone of influence of the pumping well are recommended to monitor possible natural changes in head.

In general, observation wells completed in a confined ground water zone can be spaced further from the pumping well than those completed in an unconfined zone. The decline in the piezometric surface of confined zones spreads rapidly because the release of water from storage is entirely due to compressibility of water and the ground water zone material. Water movement in unconfined zones is principally from draining of pores, which results in a slower expansion.

Under isotropic conditions, the distribution of the observation wells around the pumping well can be arbitrary. However, an even distribution is desirable so that drawdown measurements represent the largest volume as possible (Dawson and Istok, 1991). If feasible, at least three wells should be logarithmically spaced to provide at least one logarithmic cycle of distance-drawdown data (Walton, 1987). If anisotropic conditions exist or are suspected, then a single row of observation wells is not sufficient to estimate the directional dependence of transmissivity. A minimum of three observation wells, none of which are on the same radial arc, is required to separate the anisotropic behavior.

The length of the pumping well screen can have a strong influence on the distance of the observation wells from the pumping well. Partially penetrating pumping wells will induce vertical flow, which is most noticeable near the well. As a result, water level measurements taken from these wells need to be corrected; however, the effects of vertical flow become more negligible at increasing distances from the pumping well. For partially penetrating pumping wells, corrections to the drawdown data may not be necessary if the following relation holds true (Sevee, 2006; and Dawson and Istok, 1991):

$$MD \geq 1.5D \sqrt{\frac{K_H}{K_V}}$$

where:

MD = minimum distance between pumping well and observation well

D = saturated thickness

KH = horizontal K

KV = vertical K.

Drawdown measured in observation wells located less than the minimum distance should be corrected. Typically, horizontal K is ten times greater than vertical K. If this ratio is used, then the minimum distance becomes $1.5D/10$. Note that partially penetrating wells located at or greater than the minimum distance may be too far away to show drawdown.

Anticipated boundary conditions (for example, an impervious zone or a recharging river) also can affect the placement of observation wells. Wells should be placed to either minimize the effect of the boundary or more precisely locate the discontinuity (Dawson and Istok, 1991). According to Walton (1987), to minimize the effect of the boundary on distance-drawdown data, wells should be placed along a line through the pumping well and parallel to the boundary. Observation wells also should be placed on a line perpendicular to the boundary. If more than one boundary is suspected or known, the wells should be located so that the effects on drawdown data encountered by the first boundary have stabilized prior to encountering the second boundary (Sevee, 2006).

Observation points in nearby surface water bodies can be monitored to help determine if interconnection exists between the ground water and surface water.

3.4 Duration of Pumping

The appropriate duration of a pumping test depends on the hydrogeologic setting, boundary conditions, degree of accuracy desired and objectives of the test. In general, longer tests are needed to address boundary conditions; while shorter tests may be acceptable to determine hydraulic parameters. Economic factors and time constraints also may be influential; however, economizing the period of pumping is not recommended. The cost of continuing a test is low compared to total costs, particularly when the wells have been specially constructed and positioned for test purposes (Kruseman and de Ridder, 1990).

Pumping tests commonly last from five hours to five days (Walton, 1962). In some cases, tests may need to be continued until the cone of depression has stabilized and does not expand as pumping continues (for example, drawdown does not appreciably increase/decrease). Such a steady state or equilibrium can occur within a few hours to weeks or never. According to Kruseman and de Ridder (1990), the average time to reach steady state in a leaking ground water zone is 15 to 20 hours. A test of a confined ground water zone should last a minimum of 24 hours. Three days or more should be allowed for tests conducted in unconfined zones because of the slow expansion of the cone of depression. The duration necessary to define the hydraulic parameters depends on the regional and local geologic/hydrogeologic setting. Plotting drawdown data during tests often reveals anomalies and the presence of suspected or unknown boundaries, and assists in determining test duration.

3.4.1 Discharge Rate Measurement

Variation in discharge rates produces aberrations in drawdown that are difficult to treat in data analysis. Engines, even those equipped with automatic speed controls, can produce variations up to 20 to 25 percent over the course of a day. The rate should never vary by more than five percent (Osborne, 1993). To obtain reliable data, discharge should be monitored, and adjustments made as needed.

The frequency of measurements depends on the pump, engine power characteristics, the well, and the zone tested. Discharge from electric pumps should be measured and adjusted (if necessary) at 5, 10, 20, 30, 60 minutes, and hourly thereafter. Other types of pumps may require more frequent attention; however, no "rule of thumb" can be set because of the wide variation in equipment response (Stallman, 1983).

3.4.2 Discharge Measuring Devices

Some discharge measurement techniques are more accurate than others and some allow for a convenient means of adjusting rate. A commercial water meter of appropriate capacity can be utilized. It should be connected to the discharge pipe in a way that ensures accurate readings. A disadvantage is the unavoidable delay in obtaining values at the start of the test, when pumping rate is being adjusted to the desired level (Driscoll, 1986). When discharge is low, the rate can be measured as a function of time to fill a container of known volume. The orifice weir is commonly used to measure discharge from high-capacity pumps. A manometer is fitted into the discharge pipe. The water level in the manometer represents the pressure in the pipe when the water flows through the orifice. Details on orifice design and interpretation of results can be found in Driscoll (1986). Finally, discharge rate can be obtained by water level measurements taken from weirs and flumes. The rate of flow is determined within known constriction dimensions placed in the discharge channel originating at the well head (Driscoll, 1986).

3.4.3 Interval of Water Level Measurements

Pre-test Measurements

Prior to the start of tests, water level data should be collected from the pumping and observation wells to determine existing trends for all zones to be monitored. The pumping phase should begin only if identified and recorded trends are expected to remain constant. As a general rule, the period of observation should be at least twice the length of the estimated time of pumping (Stallman, 1983). Water levels should be measured and recorded hourly for all zones. In addition, the barometric pressure should be monitored, at least hourly, to determine the barometric efficiency of ground water zone(s), which may be useful in correcting the drawdown data. Barometric efficiency is discussed later in this chapter.

Measurements During Pumping

The appropriate time interval for water level measurements varies from frequent at the beginning of a test, when water-levels are changing rapidly, to long at the end of the test, when change is slow. Typical intervals for the pumping well and observation wells located close to the pumping well are given in Tables 4.4 and 4.5, respectively. Though specified intervals need not be followed rigidly, each logarithmic cycle should contain at least 10 data points spread through the cycle (Stallman, 1983). Frequent readings are essential during the first hour since drawdown occurs at a faster rate in the early time interval. For wells further away and those located in zones above or below the pumping zone, the measurements recommended by Table 4.5 within the first few minutes of the pumping test are less important (Kruseman and de Ridder, 1990).

Table 4.4 Range of interval between water-level measurements in the pumping well (Kruseman and de Ridder, 1990).

Time Since Start of Pumping Time Interval	
0 to 5 minutes	0.5 minutes
2 to 60 minutes	5 minutes
60 to 120 minutes	20 minutes
120 to shutdown of the pump	60 minutes

Table 4.5 Range of intervals between water-level measurements in observation wells (Kruseman and de Ridder, 1990).

Time Since Start of Pumping	Time Interval
0 to 2 minutes	approx. 10 seconds
2 to 5 minutes	30 seconds
5 to 15 minutes	1 minute
50 to 100 minutes	5 minutes
100 minutes to 5 hours	30 minutes
5 hours to 48 hours	60 minutes
48 hours to 6 days	3 times a day 1 time a day
6 days to shutdown of the pump	

According to Stallman (1983), it is not necessary to measure water levels in all wells simultaneously, but it is highly desirable to achieve nearly uniform separation of plotted drawdowns on a logarithmic scale. All timepieces used should be synchronized before the test is started, and provisions made to notify all participants at the instant the test is initiated.

Measurements During Recovery

After pumping is completed, water level recovery should be monitored with the same frequency used during pumping. Measurements should commence immediately upon pump shut down and continue for the same duration as the pumping phase, or until the water levels have reached 95 percent of the initial, pre-pumping static water level. A check valve should be used to prevent backflow of water in the riser pipe into the well, which could result in unreliable recovery data.

3.5 Water Level Measurement Devices

The most accurate recording of water level changes is made with fully automatic microcomputer-controlled systems that use pressure or acoustic transducers for continuous measurements. Water levels can also be determined by hand, but the instant of each reading must be recorded with a chronometer. Measurements can be performed with floating steel tape equipped with a standard pointer, electronic sounder or wet-tape method. For observation wells close to the pumped well, automatic recorders programmed for frequent measurements are most convenient because water level change is rapid during the first hour of the test. For detailed descriptions of automatic recorders, mechanical and electric sounders, and other tools, see Driscoll (1986), Dalton et al. (2006), and ASTM D4750-87 (2001). TGM Chapter 10 contains a summary of manual devices.

The measurement procedure should be standardized and the instrument calibrated prior to the start of the test. Transducers should be calibrated by a direct method, and the calibration should be checked at the conclusion of the recovery test.

3.6 Discharge of Pumped Water

Water extracted during a pumping test must be discharged properly and in accordance with any applicable laws and regulations. At sites with contaminated ground water, the discharge may need to be containerized and sampled to assess the presence of contaminants and, if necessary, treated and/or disposed at an appropriate permitted facility.

It is not the intent of this document to define Ohio EPA policy on disposal of pumped water. In general, the water should be evaluated to determine if it is characteristically a waste. If the ground water has been contaminated by a listed hazardous waste, the ground water is considered to "contain" that waste, and must therefore be managed as such. Disposal must be at a permitted hazardous waste facility. Treatment must be in a wastewater treatment system that is appropriate for the waste and meets the definitions contained in OAC rule 3745-50-10.

If containerization is not necessary, then pumped water must be discharged in a manner that prevents recharge into any zone being monitored during the test. At a minimum, the water should be discharged 100 to 200 meters from the pumped well. This is particularly important when testing unconfined zones. At no time should the discharge water be injected back into the subsurface. A permit for discharge via stream or storm sewer may be required (contact the Division of Surface Water, Ohio EPA).

3.7 Decontamination of Equipment

Decontamination of equipment is important throughout an in-situ test. Contact of contaminated equipment with ground water (or a well) may cause a measuring point to be unsuitable for water quality investigations. Details on appropriate methods can be found in TGM Chapter 10.

4.0 Correction to Drawdown Data

Prior to using the drawdown data collected from a pumping test, it may be necessary to correct for either external sources or effects induced by the test. Barometric pressure changes, tidal or river fluctuations, natural recharge and discharge, and unique situations (for example, a heavy rainfall) may all exert an influence. In confined and leaky ground water zones, changes in hydraulic head may be due to influences of tidal or river-level fluctuations, surface loading or changes in atmospheric pressure.

Diurnal fluctuations in water levels can occur in unconfined zones due to the differences between night and day evapotranspiration. Corrections to measurements may be needed for unconfined ground water zone data due to a decrease in saturated thickness caused by the pumping test. Also, corrections may be necessary if the pumping well partially penetrates the zone tested. By identifying pre-test water level trends in zone(s) of interest, long and short-term variations can be eliminated from the data if their impacts are significant during the pumping phase (Figure 4.3).

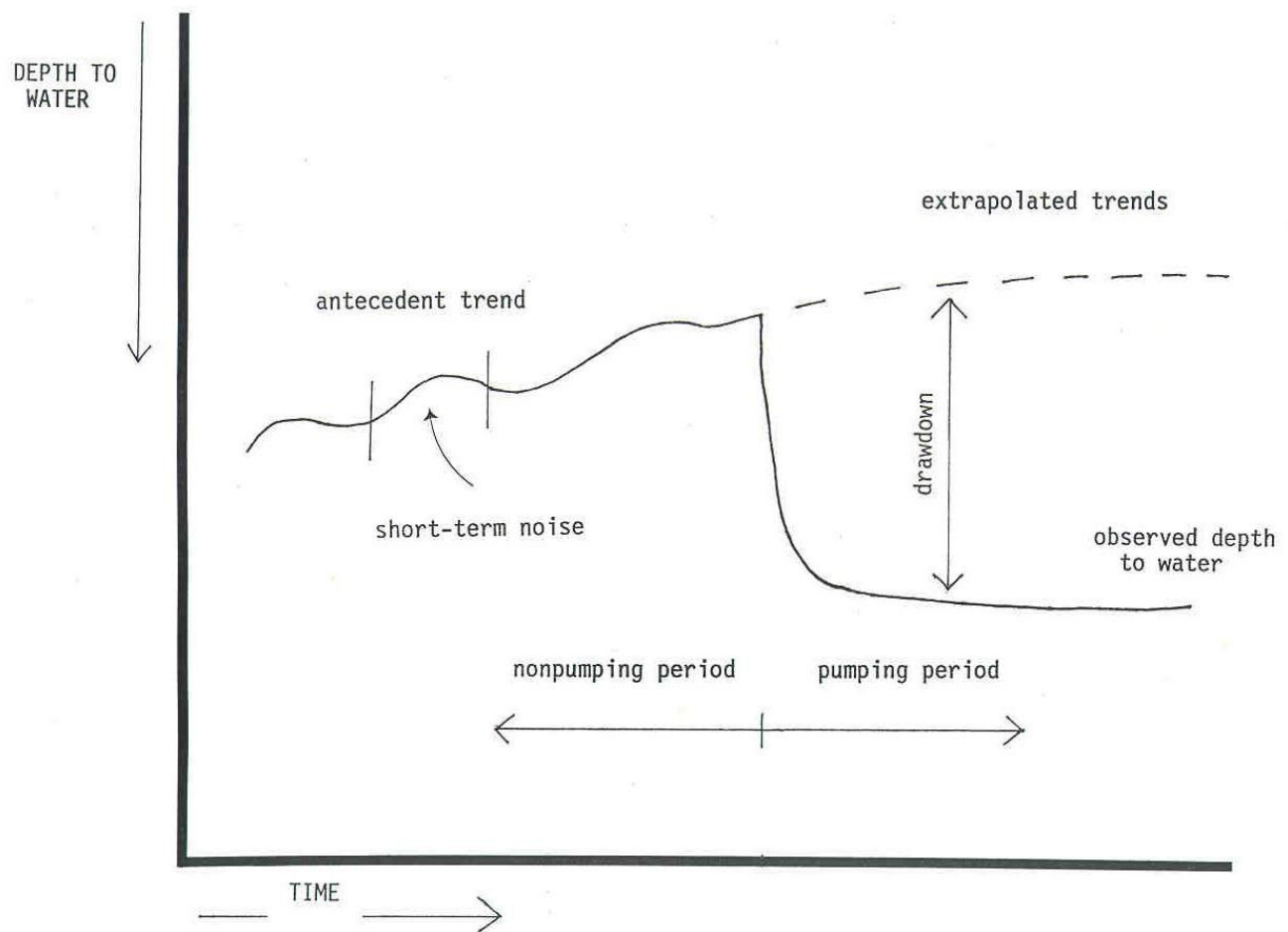

Figure 4.3 Hydrograph for hypothetical observation well showing definition of drawdown (adapted from Stallman, 1983).

To determine if corrections are necessary, measurements should be taken during the test in observation wells unaffected by the pumping. Hydrographs of the pumping and observation wells covering a sufficient period of pre-test and post-recovery periods can help determine if the data needs to be corrected and to correct the drawdown data. If the same constant water level is observed during the pre-testing and post-recovery periods, it can safely be assumed that no external events exerted an influence (Kruseman and

de Ridder, 1990).

4.1 Barometric Pressure

Data for confined and leaky zones needs to be corrected for the amount of rise in water levels resulting from a decrease in atmospheric pressure and/or the amount of fall resulting from an increase. To make the correction, the barometric efficiency (BE) of the zone needs to be determined. The BE can be calculated by the following equation [Dawson and Istok (1991) and Kruseman and de Ridder (1990)]:

$$BE = \frac{\partial h}{\partial p / \gamma_w} \times 100\%$$

where:

∂h = change of head in observation well

∂p = change in atmospheric pressure

γ_w = specific weight (density) of water

If the change in hydraulic head is plotted versus the change in pressure (measured column height) and a best-fit straight line is drawn, then the slope of the line is the BE. From changes in atmospheric pressure observed during the test and the BE, the change in water level due to changes in barometric pressure can be calculated and the drawdown data can be corrected. When artesian zones are tested, barometric pressure (to a sensitivity of +/- 0.01 inch of mercury) should be recorded continuously throughout the testing period. Barometric efficiency typically ranges between 0.20 and 0.75 (Kruseman and de Ridder, 1990).

4.2 Saturated Thickness

The saturated thickness of an unconfined zone decreases during pumping tests; however, most conceptual models assume that it remains constant. This assumption can be accepted if the saturated thickness does not decrease more than 25 percent. If the decrease is greater than 25 percent, then the drawdown data should be corrected prior to analysis (Dawson and Istok, 1991).

According to Jacob (1944), data for unconfined zones can be corrected for saturated thickness change with the following equation:

$$S_{\text{corrected}} = s - s^2/2m \text{ where: } S_{\text{corrected}} = \text{corrected drawdown}$$

m = initial saturated thickness

However, this correction is based on the Dupuit-Forchheimer assumption (ground water flows horizontally and hydraulic gradient is equal to the slope of the water table). Neuman (1975) showed that this assumption is not valid for an unconfined until the later portion of the test when the drawdown matches the Theis type curve. Therefore, the correction is not recommended with early and intermediate data (Dawson and Istok, 1991).

4.3 Unique Fluctuations

Data cannot be corrected for unique events such as a heavy rain or sudden fall or rise of a nearby river that is hydraulically connected to the zone tested. However, in favorable circumstances, some allowances can be made for the resulting fluctuations by extrapolating data from a controlled piezometer outside the zone of influence. In most cases, the data collected is rendered worthless and the test must be repeated when the situation returns to normal (Kruseman and de Ridder, 1990). It is also important to understand the effects of nearby industrial or municipal pumping wells prior to conducting a pumping test. Also, it may be necessary to monitor/evaluate the effects of surficial loading (for example, passing trains) on water level measurements.

4.4 Partially Penetrating Wells

In some cases, a ground water zone is so thick that it is not justifiable to install a fully penetrating well, and the zone must be pumped by a partially penetrating well. Partial penetration causes vertical flow in the vicinity of the well, which results in additional head loss. As indicated earlier, this effect decreases with increasing distance from the pumping well and no correction is necessary if the observation well is at a distance greater than $1.5D/KH/KV$. Various methods have been developed to correct data for the effects of partially penetrating wells. These were discussed in detail by Kruseman and de Ridder (1990). Table 4.6 lists the methods and their general applications.

4.5 Noordbergum Effect

The Noordbergum effect (also called the Mandel-Cryer effect) is observed in observation wells monitored in an upper or lower zone above the pumping zone. A rise in water levels may occur in these units due to compression of the aquitard and an increase in pore pressure or, equivalently, a hydraulic buildup (instead of the expected drawdown). The effects generally occur early and die with time. See Sara (2003) for additional explanation.

Table 4.6 Corrections for partially penetrating effects (information derived from Kruseman & de Ridder, 1990).

Method	Application	Original Source
Huisman Method I	<ul style="list-style-type: none"> - confined - steady state 	Anonymous, 1964
Huisman Method II	<ul style="list-style-type: none"> - confined - unsteady state - time of pumping relatively short 	Hantush (1961 a, 1961 b)
Hantush Modification of Theis Method	<ul style="list-style-type: none"> - confined - unsteady state - time of pumping relatively short 	Hantush (1961 a, 1961 b)
Hantush, Modification of Jacob Method	<ul style="list-style-type: none"> - confined - unsteady state - time of pumping relatively long 	Hantush (1961 b)
Weeks', "Modification of Walton and the Hantush Curve Fitting Methods"	<ul style="list-style-type: none"> - leaky - steady state flow 	Weeks (1969)
Streltsova's Curve Fitting Method	<ul style="list-style-type: none"> - unconfined - anisotropic - unsteady state 	Streltsova (1974)
Neuman's Curve- Fitting Method	<ul style="list-style-type: none"> - unconfined - anisotropic 	Neuman (1974, 1975, 1979)

5.0 Analysis of Multiple Well Pumping Test Data

Many methods (for example, Theis, Cooper-Jacob, etc.) and computer software programs exist for interpreting multiple well pumping test data. The hydraulic properties computed by a particular method can only be considered correct if the assumptions included in the conceptual model on which the method is based are valid for the particular system being tested. Because the computed values depend on the choice of conceptual model used to analyze the data, the selection of an appropriate model is the single most important step in analysis (Dawson and Istok, 1991).

It is beyond the scope of this document to detail or discuss the various models. Tables 4.7 through 4.11 can be used for a preliminary selection of a method. In addition, ASTM Method D4043-96 (2004) provides a decision tree for the selection of a test method and ASTM Methods D4106-96 (2004) and D4105-96 (2002) offer information on determining hydraulic parameters. In addition to ASTM standards, information on aquifer analysis conceptual models and/or programs can be found in: Batu (1998) Dawson and Istok (1991), and Kruseman and de Ridder (2000).

Data collected during a pumping test are subject to a variety of circumstances that may be recognized in the field or may not be apparent until data analysis has begun. In either case, all information (including field observations) must be examined during data correlation and analysis.

5.1 Presentation of Multiple Well Tests Data

The guidelines below recommend the minimum criteria for how multiple well test data should be compiled, presented and summarized to document that the hydraulic properties of the zone(s) of interest have been adequately determined.

- Preliminary evaluation of hydrogeologic conditions, including all data used to plan and design the test.
- Summary of the design and implementation of the pumping tests including, but not limited to:
 - Geologic zone into which the pumping well is completed (for example, areal extent, thickness, lateral and vertical extent).
 - Pumping well construction (justification should be provided if the well screen is partially penetrating).
 - Duration of pumping.
 - Rate of pumping and method for determination. Location of all observation wells.
 - Geologic zone(s) to be monitored (including depths, thickness, spatial relationship to the pumped zone).
 - Observation and pumping well construction.
 - Method of water level measurements (for each well).
 - Methods for gathering data used to correct drawdown and establishment of existing trends in water levels.
 - Procedures for the discharge and disposal (if necessary) of pumped water.
 - Date and time pumping began and ended.
- Raw data, including water level measurements, time of measurement in minutes after pumping started or ended, drawdown, pumping rates, etc. should be included in tabular form. All data should be expressed in consistent units. Water level in nearby surface water bodies should also be provided, if taken. If the data set is large, it may be provided on disk.
 - Data plots and type curves. All graphs and data plots should be labeled clearly.

- Data plots of (for example, drawdown versus time) should be presented for the pumping well and each observation well on double-logarithmic and semi-logarithmic paper. Time data (in minutes) should be depicted along the horizontal axis, and drawdown should be depicted along the vertical axis. For semi-logarithmic plots, drawdown should be presented along the vertical arithmetic axis.
- The horizontal scale should be the same for all data plots.
- All data points on the plots should be clearly labeled. In the event data from multiple wells are presented on the same plot, the labeling should be distinct to enable differentiation between sets of data, and be identified in a legend.
- Data plots of drawdown versus distance from the pumping well should be presented; calculations of hydraulic properties based on these plots should be used to corroborate calculations made from time drawdown data plots.
- Data plots of residual drawdown versus time since pumping stopped should be presented for recovery data.
- Data plots of discharge rate versus time should be presented.
- For data depicted on double-logarithmic plots, the following requirements should be met: If a single type curve has been used to analyze the data, the type curve should be presented directly on the data plot.
- If an analysis method employing a family of type curves has been used, all curves selected to fit the data (including both early and late time responses to pumping, if applicable) should be depicted directly on the data plot, and a discussion addressing the applicability of using multiple type curves should be included in the site investigation report.
- Match point values should be identified on data plots.
- For data depicted on semi-logarithmic plots, the portion of the data to which a straight line is fit should be indicated on the plot.
- Calculations. Equations used for calculating hydraulic properties should also be included in the report.
- In the event any boundaries are encountered by the cone of depression during the test, the report should contain: (1) a reference to the data plot on which the boundary's impact can be observed; (2) identification of the type of boundary; and (3) a discussion addressing the boundary's effect on the hydraulics at the site. For pumping wells, an evaluation of casing storage effects should be included
- Comments noting any external events (for example, change in weather patterns, passage of train or heavy machinery). In the event drawdown data need adjustment due to external effects or reduction in saturated thickness, separate data plots depicting both adjusted and unadjusted drawdown versus time and versus distance should be presented for the appropriate wells. Any plots, graphs, or equations used to determine the magnitude of drawdown adjustment should also be presented.
- Data analysis method and/or programs, including assumptions, limitations and their applicability to the site.
- In the event a computer program is used to perform the analysis, only those software programs that provide analysis of the data based on graphical curve matching, rather than least-squares analysis, and allow for the generation of data plots should be used.

- Interpretation of the data using both results of the test and other available hydrogeologic information.

5.2 Recovery Tests

Recovery tests (also called residual drawdown tests) involve measuring water level rise after the pump is shut down. These tests provide an independent check on the transmissivity and storativity determined from a pumping test. The results should be used in conjunction with calculations obtained from the pumping phase to estimate the true hydraulic properties of the zone(s) of interest. Results of a recovery test can be more reliable than pumping test results because recovery is not influenced by the erratic fluctuations that can be characteristic of pumping.

As with the early portions of the pumping phase in which water levels drop rapidly, water levels rise rapidly during early portions of the recovery phase and are followed by a decreasing rate of water level rise. It is therefore important to establish the same schedule for obtaining water level measurements during the initial portions of the recovery phase as that used during the pumping phase (Kruseman and de Ridder, 1990). Table 4.12 provides methods for analyzing recovery data.

At a minimum, the following information should be provided: date and time the pumping phase ended and the recovery phase began; initial and final water levels for the recovery phase; time since pumping stopped (in minutes); measured water level; residual drawdown; and records of any noteworthy occurrences.

Table 4.7 Multiple-well, constant discharge pumping tests, unconfined ground water zone.

General Assumptions				
1) The ground water zone is unconfined and bounded below by an aquiclude.				
2) All layers are horizontal and extend infinitely in the radial extent.				
3) The ground water zone is homogeneous, isotropic (unless noted) and of uniform thickness.				
4) Prior to pumping, the water table is horizontal over the area that will be influenced by the test.				
5) Ground water density and viscosity are constant.				
6) Ground water flow can be described by Darcy's Law.				
7) Head losses through well screen and pump intake are negligible.				
8) The ground water zone is compressible and completely elastic.				
9) The zone has been pumped long enough that equilibrium has been reached.				
10) Drawdown is small compared to the saturated thickness (for example, no more than 25 percent).				
11) Pumping and observation wells are screened over the entire saturated thickness (unless noted).				
12) Ground water flow above the water table is negligible.				
Method	Can Account For			Remarks
	Flow Conditions	Partial Penetration	Other	
Neuman's Curve Fitting Method (Neuman, 1972) (a,b)	Transient	No	anisotropic conditions	Theory should be valid for piezometers with short screens provided that the drawdowns are averaged over the saturated thickness (Van der Kamp, 1985)
Thiem-Dupuit's Method, (Thiem, 1906) (b)	Steady state	No		Steady state will only be achieved after long pumping time Does not give accurate description of drawdown near the well Assumptions ignore the existence of a seepage face at the well and the influence of the vertical velocity component
Boulton and Streltsova (1976)	Transient	Yes	storage in the well anisotropy	
Neuman (1974) (a)	Transient	Yes	anisotropy	

a Described in Dawson and Istok, 1991

b Described in Kruseman and de Ridder, 1990

Table 4.8 Multiple-well, constant-discharge pumping tests, confined ground water zones.

General Assumptions				
<ol style="list-style-type: none"> 1) The ground water zone is confined and bounded above and below by aquicludes. 2) The ground water zone is homogeneous, isotropic (unless noted in special conditions) and of uniform thickness over the area influenced by the test. 3) All layers are horizontal and extend infinitely in the radial extent. 4) Prior to pumping, the piezometric surface is horizontal and extends infinitely in the radial direction. 5) Ground water density and viscosity are constant. 6) Ground water can be described by Darcy's Law. 7) Head losses through well screen and pump intake are negligible. 8) Ground water flow is horizontal and is directed radially to the well. 9) Pumping well and observation wells are screened over the entire thickness of the ground water zone. 				
Additional assumptions for unsteady state flow.				
<ol style="list-style-type: none"> 1) The water removed from storage is discharged instantaneously with decline of head. 2) The diameter of the well is small, i.e., the storage in the well can be neglected. 				
Method	Application			Remarks
	Can Account For			
	Flow Conditions	Partial Penetration	Other	
Thiem (1906) (a,b)	Steady state	No		Equation should be used with caution and only when other methods cannot be applied. Drawdown is influenced by well losses, screen and pump intake.
Theis (1935) (a,b)	Transient	No		Because there may be a time lag between pressure decline and release of stored water, early drawdown data may not closely represent theoretical drawdown data.
Hantush (1964) (b)	Transient	Yes	Anisotropy in the horizontal plane	Inflection point method can be used when the horizontal and vertical hydraulic conductivities can be reasonably estimated.
Jacob's Method (Cooper and Jacob, 1946) (b)	Transient	No		Can also be applied to single well pump tests. Condition that u values are small usually is satisfied at moderate distances from the well within an hour or so. at $u < 0.05$ or 0.10 , error introduced is two and five percent respectively. Based on Theis Equation, straight line method based on drawdown versus time on semi-log paper.

Table 4.8 (continued). Multiple-well, constant discharge pumping tests, confined.

Method	Application			Remarks
	Can Account For			
	Flow Conditions	Partial Penetration	Other	
Weeks (1969) (b)	Transient	Yes	Anisotropy in the vertical plane	Similar procedure can be applied to leaky ground water zones.
Papadopulos (1965) (a)	Transient	No	Anisotropy in horizontal plane	Minimum of three observation wells.
Papadopulos and Cooper (1967) (a)	Transient	No	Well Storage	Pumping rate is the sum of the ground water entering in the pumping well from the zone and the rate of decrease of water stored in well casing.
Neuman's Extension of Papadopulos (Neuman et al., 1984) (b)	Transient	No	Anisotropy in the horizontal plane	More reliable results can be obtained by conducting three pumping tests. The zone is penetrated by at least three wells, which are not on the same ray.
Hantush (1966) (b)	Transient	No	Anisotropy in the horizontal plane	If the principal direction of anisotropy is known, drawdown data from two piezometers on different rays is sufficient. If not, three wells on different rays will be needed. Use of Theis (1906) or Cooper and Jacob (1946).
Hantush and Thomas (1966) (b)	Transient	No	Anisotropy in the horizontal plane	Apply methods for confined isotropic ground water zones to the data for each ray of piezometers.

a Described in Dawson and Istok (1991)

b Described in Kruseman and de Ridder (1990)

Table 4.9 Multiple-well, Constant discharge pumping tests, leaky ground water zones.

General Assumptions				
<ol style="list-style-type: none"> 1) The ground water zone is leaky. 2) The ground water zone and aquitard have seemingly infinite and areal extent. 3) The ground water zone and aquitard are homogeneous, isotropic (unless noted), and of uniform thickness over the area influenced by the test. 4) Prior to pumping, the piezometric surface and the water table are horizontal over the area that will be influenced by the test. 5) The well penetrates the entire thickness of the zone and thus receives water by horizontal flow (unless noted). 6) The flow in the aquitard is vertical. 7) The drawdown in the unpumped ground water zone (or aquitard) is negligible. 8) Ground water flow can be described by Darcy's Law. 				
Additional assumptions for transient conditions:				
<ol style="list-style-type: none"> 1) Water removed from storage and the water supplied by leakage from the aquitard is discharged instantaneously with decline of head. 2) The diameter of the well is very small, for example, the storage in the well can be neglected. 				
Method	Can Account For			Remarks
	Flow conditions	Partial Penetration	Other	
De Glee (1930 & 1951) (b)	steady state	No		
Hantush (1960) (b)	Transient	No	Takes into account storage changes in the aquitard	Only the early-time drawdown should be used to satisfy the assumption that the drawdown in the aquitard is negligible. Generally is This equation plus an error function.
Hantush-Inflection Point (1956) (a,b)	Transient	No		Accuracy depends on accuracy of extrapolating the maximum drawdown. Two different methods, one requires one piezometer, and the other requires data from two piezometers.
Hantush-Jacob (1955) (b)	Steady state	No		
Lai and Su (1974) (a,b)	Transient	No		
Neuman-Witherspoon (1972) (b)	Transient	No		Need to calculate transmissivity using one of the other methods.

Table 4.9 (continued). Multiple-well, constant discharge, pumping tests, leaky.

Method	Can Account For			Remarks
	Flow Conditions	Partial Penetration	Other	
Hantush-Jacob (1955) (a)	Transient	No		Drawdown in the source bed can be neglected when KD of source bed is $>100 KD$ of ground water zone. Ground water zone is bounded above by aquitard and an unconfined ground water zone and bounded below by an aquiclude. Ground water flow in the aquitard is vertical.
Walton (1962) (b)	Transient	No		To obtain the unique fitting position of the data plot with one of the type curves, enough of the observation data should fall within the period when leakage effects are negligible.
Hantush (1966) (b)	Transient	No	Anisotropic in horizontal plane	Similar to Hantush's methods for confined zone except initial step uses methods to calculate the hydraulic parameters.
Weeks (1969) (b)	Transient	Yes	Anisotropic in the vertical plane	Similar process can be conducted for confined zone.

a Described in Dawson and Istok, 1991

b Described in Kruseman and de Ridder, 1990

t = time since start of pumping, S' = aquitard storativity, D' = saturated thickness of aquitard, D = saturated thickness of the ground water zone, K' = hydraulic conductivity of aquitard

Table 4.10 Pumping tests, variable discharge.

Method*	Application	Assumptions	Remarks
Birsoy and Summers (1980)	<ul style="list-style-type: none"> - Confined - Transient - Pumped step-wise or intermittently at variable rates 	<ul style="list-style-type: none"> - General assumptions for confined ground water zones. 	Tedious process
Aron and Scott (1965)	<ul style="list-style-type: none"> - Confined - Transient - Discharge rate decreases 	<ul style="list-style-type: none"> - General assumptions for confined ground water zones. - Discharge rate decreases with time sharpest decrease occurring soon after the start of pumping. 	Analogous to the Jacob Method
Hantush (1964)	<ul style="list-style-type: none"> - Confined - Transient 	<ul style="list-style-type: none"> - Standard assumptions for confined ground water zones. - At the start of the tests, the water level in the free flowing well drops instantaneously. At $t>0$ drawdown is constant and its discharge rate is variable. 	
Hantush-De Glee Method (Hantush, 1959b)	<ul style="list-style-type: none"> - Leaky - Transient - Fully penetrating well 	<ul style="list-style-type: none"> - Standard assumptions for leaky ground water zones (see leaky section). - At the start of the tests, the water level in the free flowing well drops instantaneously. At $t>0$ drawdown is constant and its discharge rate is variable. 	

* Methods described in Kruseman and de Ridder (1990).

Table 4.11 Methods of analysis for pumping tests with special conditions.

Ground Water Zone Condition	Flow	Type	Models and Sources*
One or more recharge boundaries	Steady State	Confined or Unconfined	Dietz (1943)
One or more straight recharge boundaries	Unsteady State	Confined or Unconfined	Stallman (in Ferris et al., 1962)
One recharge boundary	Unsteady State	Confined or Unconfined	Hantush (1959a)
Bounded by two fully penetrating boundaries	Unsteady State	Leaky or Confined	Vandenberg (1976 and 1977)
Wedge shaped ground water zones	Unsteady State	Confined	Hantush (1962)
Water table slopes	Steady State	Unconfined	Culmination Point Method (Huisman, 1972)
	Unsteady State	Unconfined	Hantush (1964)
Two layered ground water zone, unrestricted cross flow Pumping well does not penetrate entire thickness	Unsteady State	Confined	Javandel-Witherspoon (1983)
Leaky two-layered ground water zone, separated by aquitard with cross-flow across aquitard	Steady State	Leaky	Bruggeman (1966)
Large diameter well	Unsteady State	Confined	Papadopoulos (1967), Papadopoulos and Cooper (1967)
Large diameter well	Unsteady State	Unconfined	Boulton and Streltsova, (1976)

* Sources are described in Kruseman and de Ridder, 1990.

Table 4.12 Recovery test methods (discussed in Kruseman and de Ridder, 1990).

Method	Application	Source
Theis Recovery Methods	<ul style="list-style-type: none"> - Confined Unsteady state - Recovery after constant discharge 	Theis (1935)
	<ul style="list-style-type: none"> - Leaky Unsteady state - Recovery after constant discharge 	Vandenberg (1975) Hantush (1964)
	<ul style="list-style-type: none"> - Unconfined - Recovery after constant discharge - Late recovery data 	Neuman (1975)
	<ul style="list-style-type: none"> - Unconfined - Recovery after constant drawdown 	Rushton and Rathod (1980)
Birsoy and Summers	<ul style="list-style-type: none"> - Unconfined - Recovery after variable discharge 	Birsoy and Summers (1980)

6.0 References

- Anonymous, 1964. Steady Flow of Groundwater Towards Wells. Proc. Comm. Hydrology. Research TNO No.10. Cited in Kruseman and de Ridder, 1990.
- Aron, G. and V. H. Scott. 1965. Simplified Solution for Decreasing Flow into Wells. American Society of Civil Engineers Proceedings. Vol. 91, No. HY5, pp. 1-12.
- ASTM, Method D4043-96 (2004). Standard Guide for the Selection of Aquifer-Test Methods in Determining the Hydraulic Properties by Well Techniques. ASTM International, West Conshohocken, Pennsylvania.
- ASTM, Method D4044-96(2002). Standard Test Method (Field Procedure) for Instantaneous Change in Head (Slug Tests) for Determining Hydraulic Properties of Aquifers. ASTM International, West Conshohocken, Pennsylvania.
- ASTM, Method D4104-96 (2004). Standard Test Method (Analytical Procedure) for Determining Transmissivity of Nonleaky Confined Aquifers by Overdamped Well Response to Instantaneous Change in Head (Slug Test). ASTM International, West Conshohocken, Pennsylvania.
- ASTM, Method D4105-96(2002). Standard Test Method (Analytical Procedure) for Determining Transmissivity and Storage Coefficient of Nonleaky Confined Aquifers by the Modified Theis Nonequilibrium Method. ASTM International, West Conshohocken, Pennsylvania.
- ASTM, Method D4106-96 (2004). Standard Test Method (Analytical Procedure) for Determining Transmissivity and Storage Coefficient of Nonleaky Confined Aquifers by the Modified Theis Nonequilibrium Method. ASTM International, West Conshohocken, Pennsylvania.
- ASTM, Method D4361-95 (2000). Standard Test Method for Determining Transmissivity and Storativity of Low Permeability Rocks by In Situ Measurements Using Pressure Pulse Technique. ASTM International, West Conshohocken, Pennsylvania.
- ASTM, Method D4750-87(2001). Standard Test Method for Determining Subsurface Liquid Levels in a Borehole or Monitoring Well (Observation Well). ASTM International, West Conshohocken, Pennsylvania.
- Batu, Vedat. 1998. Aquifer Hydraulics: A Comprehensive Guide to Hydrogeologic Data Analysis. John Wiley & Sons, Inc. 727pp.
- Birsoy, Y. K. and W. K. Summers. 1980. Determination of Aquifer Parameters from Step Tests and Intermittent Pumping Data. Ground Water. Vol. 18, No. 2, pp. 137- 146.
- Black, J. H. 1978. The Use of Slug Tests in Ground Water Investigations. Water Services. pp. 174-178.
- Boulton, N. S. and T. D. Streltsova. 1976. The Drawdown Near an Abstraction of Large Diameter Under Non-Steady State Conditions in Unconfined Aquifers. Journal of Hydrology. Vol. 30, pp. 29-46.
- Bouwer, H. and R. C. Rice. 1976. A Slug Test For Determining Hydraulic Conductivity of Unconfined Aquifers with Complete or Partially Penetrating Wells. Water Resources Research. Vol. 12, No. 3, pp. 423-428.
- Bouwer, H. 1989. The Bouwer and Rice Slug Test--An Update. Ground Water. Vol. 27, No. 3, pp. 304-309.
- Bredehoeft, J. D. and S. S. Papadopoulos. 1980. A Method for Determining Hydraulic Properties of Tight Formations. Water Resources Research. Vol. 16, No. 1, pp. 233-238.

- Bruggeman, G. A. 1966. Analyse van de Bodemconstanten in een Grondpakket, Bestaande Uit Twee of Meer Watervoerende Lagen Gescheiden door Semi- Permeabele Lagen. Unpublished Research Paper. Cited in Kruseman and de Ridder, 1990.
- Butler, J.J. 1998. The Design and Performance, and Analysis of Slug Tests. Lewis Publishers (imprint of CRC Press LLC.) Boca Raton, Florida. 252 pp.
- Chirlin, G.R. 1990. The Slug Test: The First Four Decades. Ground Water Management. Proceedings of the 1990 Cluster Conference. National Water Well Association. Columbus, Ohio. pp. 365-381.
- Cooper, H. H., J. D. Bredehoeft, and I. S Papadopulos. 1967. Response of a Finite- Diameter Well to an Instantaneous Charge of Water. Water Resources Research. Vol. 3, No. 1, pp. 263-269.
- Cooper, H. H. and C. E. Jacob. 1946. A Generalized Graphical Method for Evaluating Formation Constants and Summarizing Well Field History. Transactions of the American Geophysical Union. Vol. 24, No. 4, pp. 526-534.
- Dalton, M. G., B. E. Huntsman, and K. Bradbury. 2006. Acquisition and Interpretation of Water-Level Data. In: D. M. Nielsen (editor), Practical Handbook of Ground- Water Monitoring. Lewis Publishers, Inc. Chelsea, Michigan. pp.883-911.
- Dawson, K. and J. D. Istok. 1991. Aquifer Testing, Design and Analysis of Pumping and Slug Tests. Lewis Publishers, Inc. Chelsea, Michigan.
- De Glee, G. J. 1930. Over Grondwaterstromingen bij Wateronttrekking Door Middel Van Putten. Thesis. J. Waltman, Delft (The Netherlands). Cited in Kruseman and de Ridder (1990).
- De Glee, G. J. 1951. Berekeningsmethoden voor de Winning van Grondwater. In: Drinkwatervoorziening, 3e Vacantiecursus: 38-80 Moorman's Periodieke pers. The Hague. Cited in Kruseman and de Ridder, 1990.
- Dietz, D. N. 1943. De Toepassing van Invloedsfuncties bij het Berekenen van de Verlaging van het Grondwater ten Gevolge van Wateronttrekking. Water. Vol. 27(6), pp. 51-54. Cited in Kruseman and de Ridder, 1990.
- Domenico, P.A. and F.W. Schwartz. 1998. Second Edition. Physical and Chemical Hydrogeology. John Wiley and Son, Inc. New York.
- Driscoll, F. G. (editor). 1986. Groundwater and Wells. Second Edition. Wheelabrator Engineered Systems-Johnson screens. St. Paul, Minnesota.
- Fetter, C. W. 2001. Applied Hydrogeology. Fourth Edition. Prentice Hall. Uper Saddle River, New Jersey.
- Ferris, J. G., D. B. Knowles, R. H. Brown, and R. W. Stallman. 1962. Theory of Aquifer Tests. U.S. Geological Survey, Water-Supply Paper 1536E.
- Hantush, M. S. 1956. Analysis of Data From Pumping Tests in Leaky Aquifers. Transactions of the American Geophysical Union. Vol. 37, No. 6, pp. 702-714.
- Hantush, M. S. 1959a. Analysis of Data From Pumping Well Near a River. Journal of Geophysical Research. Vol. 94, pp. 1921-1923.
- Hantush, M. S. 1959b. Non-Steady Flow to Flowing Wells in Leaky Aquifers. Journal of Geophysical Research. Vol. 64, No. 8, pp. 1043-1052.
- Hantush, M. S. 1960. Modification of the Theory of Leaky Aquifers. Journal of Geophysical Research. Vol.65, No. 11, pp. 3713-3725.

- Hantush, M. S. 1961a. Drawdown Around a Partially Penetrating Well. Journal of the Hydraulics Division. Proceedings of the American Society of Civil Engineers. Vol. 87 (HY4), pp. 83-98.
- Hantush, M. S. 1961b. Aquifer Tests on Partially Penetrating Wells. Journal of the Hydraulics Division. Proceedings of the American Society of Civil Engineers. Vol. 87(HY5), pp. 172-195.
- Hantush, M. S. 1962. Flow of Ground Water in Sands of Nonuniform Thickness-- Part 3, Flow to Wells. Journal of Geophysical Research. Vol. 67, No. 4, pp. 1527-1534.
- Hantush, M. S. 1964. Hydraulics of Wells. In: V. T. Chow (editor), Advances in Hydrosociences. Vol. 1. Academic Press. London and New York. pp. 281-442.
- Hantush, M. S. 1966. Analysis of Data From Pumping Tests In Anisotropic Aquifers. Journal of Geophysical Research. Vol. 71, No. 2, pp. 421-426.
- Hantush, M. S. and C. E. Jacob. 1955. Non-Steady State Radial Flow in an Infinite Leaky Aquifer. Transactions of the American Geophysical Union. Vol. 36, No. 1, pp. 95-100.
- Hantush, M. S. and R. G. Thomas. 1966. A Method for Analyzing a Drawdown Test in Anisotropic Aquifers. Water Resources Research. Vol. 2, No. 2, pp. 281-285.
- Huisman, L. 1972. Groundwater Recovery. MacMillan.
- Hvorslev, M. J. 1951. Time Lag and Soil Permeability in Groundwater Observation. U.S. Army Corps of Engineers, Waterways Experiment Station. Bulletin No. 36. Vicksburg, Mississippi.
- Jacob, C. E. 1944. Notes on Determining Permeability by Pumping Tests Under Water Table Conditions. U.S. Geological Survey. Open file report.
- Jacob, C. E. and S. W. Lohman. 1952. Non-Steady Flow to a Well of Constant Drawdown in an Extensive Aquifer. Transactions of the American Geophysical Union. Vol. 33, pp. 559-569.
- Javandel, I. and R. A. Witherspoon. 1983. Analytical Solution of a Partially Penetrating Well in a Two-Layer Aquifer. Water Resources Research. Vol 19., pp. 567-578.
- Kruseman, G. P. and de Ridder, N. A. 1990. Analysis and Evaluation of Pumping Test Data. Second Edition. International Institute for Land Reclamation and Improvement (ILRI) Publication 47. Wageningen, The Netherlands.
- Lai, R. Y. S. and C. W. Su. 1974. Nonsteady Flow to a Large Diameter Well in a Leaky Aquifer. Journal of Hydrology. Vol. 22. pp. 333-345.
- Lohman, S. W. 1972. Groundwater Hydraulics. U.S. Geological Survey Professional Paper 708. United States Government Printing Office. Washington, D.C.
- Neuman, S. P. 1972. Theory of Flow in Unconfined Aquifers Considering Delayed Response of the Water Table. Water Resources Research. Vol. 8, No4, pp. 1031- 1045.
- Neuman, S. P. 1974. Effects of Partial Penetration on Flow in Unconfined Aquifers Considering Delayed Gravity Response. Water Resources Research. Vol. 10, No 2, pp. 303-312.
- Neuman, S. P. 1975. Analysis of Pumping Test Data From Anisotropic Unconfined Aquifers Considering Delayed Gravity Response. Water Resources Research. Vol. 11, No, 2, pp. 329-342.
- Neuman, S. P. 1979. Perspective on 'Delayed Yield'. Water Resources Research. Vol. 15, No. 4, pp. 899-908.
- Neuman, S. P. and P. A. Witherspoon. 1972. Field Determination of the Hydraulic Properties of Leaky Multiple Aquifer Systems. Water Resources Research. Vol. 8, No. 5, pp. 1284-1298.

- Neuman, S. P., G. R. Walter, H. W. Bentley, J. J. Ward and D. D. Gonzalez. 1984. Determination of Horizontal Anisotropy With Three Wells. *Ground Water*. Vol. 22, No. 1, pp. 66-72.
- Orient, J. P., A. Nazar and R.C. Rice. 1987. Vacuum and Pressure Test Methods for Estimating Hydraulic Conductivity. *Ground Water Monitoring Review*. Vol. 7, No. 1, pp. 49-50.
- Osborne, P. S. 1993. Suggested Operating Procedures for Aquifer Pumping Tests. U.S.EPA. Office of Research and Development, Office of Solid Waste. EPA/540/S- 93/503.
- Papadopoulos, I. S. 1965. Nonsteady flow to a well in a finite anisotropic aquifer. International Association of Scientific Hydrology Symposium. American Water Resources Assoc. Proc. No. 4, pp. 157-168.
- Papadopoulos, I. S. 1967. Drawdown Distribution Around a Large Diameter Well. Symposium on Groundwater Hydrology. Proceedings of American Water Resources. No. 4, pp. 157-168.
- Papadopoulos, I. S. and H. H. Cooper. 1967. Drawdown in Large Diameter Wells. *Water Resources Research*. Vol. 3, No. 1, pp. 241-244.
- Rushton, K. R. and K. S. Rathod. 1980. Overflow Tests Analyzed by Theoretical and Numerical Methods. *Ground Water*. Vol. 18, No. 1, pp. 61-69.
- Rushton, K. R. and V. S. Singh. 1983. Drawdowns in Large-diameter Wells Due To Decreasing Abstraction Rates. *Ground Water*. Vol. 21, No. 6, pp. 671-677.
- Sara, M.C. 2003. Site Assessment and Remediation Handbook. Second Edition. CRC Press, Lewis Publications.
- Sevee, J. 2006. Methods and Procedures for Defining Aquifer Parameters. In: D. M. Nielsen (editor), Practical Handbook of Ground-Water Monitoring. Taylor & Francis Group, CRC Press, Boca Raton, FL. pp. 913-958.
- Stallman, R. W. 1983. Aquifer-Test Design, Observation and Data Analysis: U.S. Geological Survey Techniques of Water-Resource Investigations, Book 3, Chapter B1. United States Government Printing Office. Washington, D. C.
- Streltsova, T. D. 1974. Drawdown in Compressible Unconfined Aquifer. *Journal of the Hydraulics Division*. American Society of Civil Engineers. HY11, pp. 1601-1616.
- Theis, C. V. 1935. The Relation Between the Lowering of the Piezometric Surface and the Rate and Duration of Discharge of a Well Using Groundwater Storage. *Transactions of the American Geophysical Union*. Vol. 16, pp. 519-524.
- Thiem, G. 1906. *Hydrologische Methoden*. Gebhardt. Leipzig. Cited in Kruseman and de Ridder, 1990.
- Uffink, G. J. M. 1984. Theory of the Oscillating Slug Test. National Institute for Public Health and Environmental Hygiene Bilthoven. Unpublished research report (in Dutch). Cited in Kruseman and de Ridder, 1990.
- U.S. EPA. 1986. Saturated Hydraulic Conductivity, Saturated Leachate Conductivity and Intrinsic Permeability. In: Test Methods for Evaluating Solid Waste. SW846, Method 9100. Office of Solid Waste and Emergency Response. U.S. Environmental Protection Agency. Washington, D.C.
- Vandenberg, A. 1975. Determining Aquifer Coefficients from Residual Drawdown Data. *Water Resources Research*. Vol. 11, pp. 1025-1028.

- Vandenberg, A. 1976. Tables and Types Curves for Analysis of Pumping Tests in Leaky Parallel-Channel Aquifers. Technical Bulletin No. 96. Inland Waters Directorate, Water Resource Branch. Ottawa (Canada).
- Vandenberg, A. 1977. Type Curve Analysis of Pump Tests in Leaky Strip Aquifers. Journal of Hydrology. Vol. 33, pp. 15-26.
- Van der Kamp, G. 1985. Brief Quantitative Guidelines for Design and Analysis of Pumping Tests. In: Hydrology in the Service of Man. Memoirs of the 18th Congress Intern. Assoc. Hydrogeol. Cambridge, Massachusetts. pp. 197-206
- Walton, W.C. 1996. Aquifer Analysis with WINDOWSTM Software. Lewis Publishers, CRC Press. 301pp.
- Walton, W. C. 1962. Selected Analytical Methods for Well and Aquifer Evaluation. Illinois State Water Survey. Bulletin No. 49.
- Walton, W. C. 1987. Groundwater Pumping Tests, Design and Analysis. Lewis Publishers, Inc. Chelsea, Michigan.
- Weeks, E. P. 1969. Determining the Ratio of Horizontal to Vertical Permeability by Aquifer-Test Analysis. Water Resources Research. Volume 5, pp. 196-214.
- Worthington, P. F. 1981. Estimation of Transmissivity of Thin Leaky-Confined Aquifers from Single-Well Pumping Test. Journal of Hydrology. Vol. 49, pp. 19-30.

Division of Drinking and Ground Waters

Technical Guidance Manual for Ground Water Investigations

Chapter 7

Monitoring Well Design and Installation

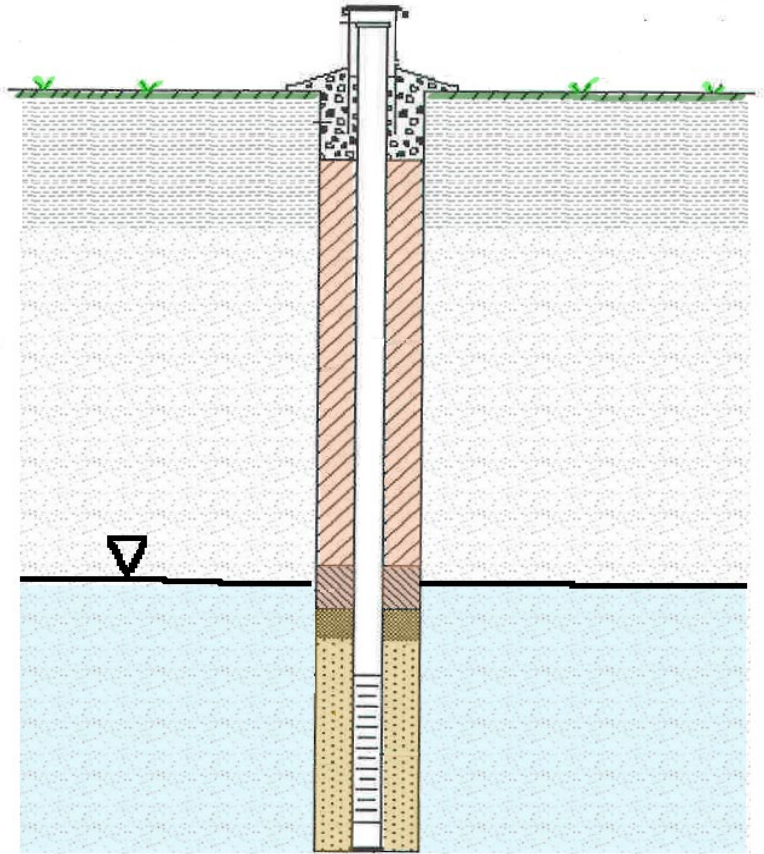

February 2008

Governor : Ted Strickland
Director : Chris Korleski



**TECHNICAL GUIDANCE
MANUAL FOR
GROUND WATER INVESTIGATIONS**

CHAPTER 7

Monitoring Well Design and Installation

February, 2008
Revision 1

Ohio Environmental Protection Agency
Division of Drinking and Ground Waters
P.O. Box 1049 50 W. Town Street, Suite 700
Columbus, Ohio 43216-1049
Phone: 614-644-2752
<http://www.epa.state.oh.us/ddagw/>

PREFACE

This document is part of a series of chapters incorporated in Ohio EPA's *Technical Guidance Manual for Hydrogeologic Investigations and Ground Water Monitoring* (TGM), which was originally published in 1995. DDAGW now maintains this technical guidance as a series of chapters rather than as an individual manual. The chapters can be obtained at <http://www.epa.state.oh.us/ddagw/tgmweb.aspx>

The TGM identifies technical considerations for performing hydrogeologic investigations and ground water monitoring at potential or known ground water pollution sources. The purpose is to enhance consistency within the Agency and inform the regulated community of the Agency's technical recommendations and the basis for them. In Ohio, the authority over pollution sources is shared among various Ohio EPA divisions, including the Emergency and Remedial Response (DERR), Hazardous Waste Management (DHWM), Solid and Infectious Waste (DSIWM), and Surface Water (DSW), as well as other state and local agencies. DDAGW provides technical support to these divisions.

Ohio EPA utilizes **guidance** to aid regulators and the regulated community in meeting laws, rules, regulations and policy. Guidance outlines recommended practices and explains their rationale. The Agency may not require an entity to follow methods recommended by this or any other guidance document. It may, however, require an entity to demonstrate that an alternate method produces data and information that meet the pertinent requirements. The procedures used to meet requirements usually should be tailored to the specific needs and circumstances of the individual site, project, and applicable regulatory program, and should not comprise a rigid step-by-step approach that is utilized in all situations.

MAJOR CHANGES FROM THE FEBRUARY 1995 TGM

The Ohio EPA Technical Guidance Manual for Hydrogeologic Investigations and Ground Water Monitoring (TGM) was finalized in 1995. This guidance document represents an update to Chapter 7 (Monitoring Well Design and Installation). Listed below are the major changes from the 1995 version.

1. Deleted language cautioning against the use of multi-level wells. Added information on multi-level well systems.
2. Added text indicating that vertical water profiles can be obtained with passive sampling techniques.
3. Revised text to state that PVC is preferable to PTFE for monitoring well screens when organics are present. Studies have shown that PTFE sorbs organic compounds at a higher rate than does PVC.
4. Added language stating that a filter pack can be much less thick than previously recommended.
5. Added language describing the use of pre-packed screen wells.
6. Changed the recommendation for selecting the screen slot size of a naturally packed well from a slot that retains 30 to 60% of the filter pack to one that retains 70%.
7. Added information on methods for creating high-solids bentonite.
8. Revised text to note potential problems with using a bentonite/cement mixture. However, the guidance does not rule it out as a potential sealant for monitoring wells. Some literature has indicated problems with the use of a bentonite as an additive to neat cement for well sealing. Because of this, the Ohio rules applying to drinking water wells do not allow the use of a bentonite/cement mixture (OAC 3745-09). However, there are also articles that favor its use, and many states still allow (and recommend) it.
9. Added section on procedures for installation of neat cement grout.
10. Added recommendation that, due to its potential to affect ground water chemistry, bentonite sealing material should be placed a minimum of 3 to 5 feet above the top of the well screen.
11. Included references to new documents that have become available since 1995, including:
 - Updated existing references.
 - Added new ASTM reference for installation of pre-packed screens.
 - Added new ASTM reference for maintenance and rehabilitation of ground water monitoring wells.
 - Added reference to the Technical Guidance for Ground Water Investigation Chapter 15 - Use of Direct Push Technologies for Soil and Ground Water Sampling.

TABLE OF CONTENTS

PREFACE.....	7-ii
MAJOR CHANGES FROM THE FEBRUARY 1995 TGM	7-iii
TABLE OF CONTENTS.....	7-iv
DESIGN OF MULTIPLE-INTERVAL SYSTEMS	7-1
WELL CLUSTERS.....	7-3
MULTI-LEVEL WELLS.....	7-3
NESTED WELLS.....	7-3
SINGLE-CASING, LONG-SCREEN WELLS.....	7-4
CASING.....	7-4
CASING TYPES.....	7-4
Fluoropolymers.....	7-4
Metallics.....	7-5
Thermoplastics.....	7-6
TYPE SELECTION.....	7-6
HYBRID WELLS.....	7-8
COUPLING MECHANISMS.....	7-8
DIAMETER.....	7-9
CASING INSTALLATION.....	7-9
INTAKES.....	7-10
FILTER PACK.....	7-10
Types of Filter Packs.....	7-10
Nature of Artificial Filter Pack Material.....	7-11
Dimension of Artificial Filter Pack.....	7-12
Artificial Filter Pack Installation.....	7-12
SCREEN.....	7-15
Screen Types.....	7-15
Pre-Packed Screen Wells.....	7-16
Slot Size.....	7-16
Length.....	7-16
OPEN BOREHOLE INTAKES.....	7-17
ANNULAR SEALS.....	7-17
MATERIALS.....	7-17
Bentonite.....	7-18
Neat Cement Grout.....	7-18
SEAL DESIGN.....	7-20
SEAL INSTALLATION.....	7-20
Bentonite.....	7-20
Neat Cement.....	7-21
SURFACE SEAL/PROTECTIVE CASING COMPLETIONS.....	7-22
SURFACE SEAL.....	7-22
FLUSH-TO-GROUND COMPLETIONS.....	7-22
DOCUMENTATION.....	7-23
MAINTENANCE AND REHABILITATION.....	7-24
REFERENCES.....	7-26

CHAPTER 7

MONITORING WELL DESIGN AND INSTALLATION

To collect representative ground water samples, it is necessary to construct monitoring wells to gain access to the subsurface. This chapter covers installation and construction of single-riser/limited interval wells, which are designed such that only one discrete zone is monitored in a given borehole, and multiple interval wells designed to measure multiple discrete depth intervals at a single location. Whether a single riser or multiple interval well is installed, it is important that efforts focus on intervals less than 10 feet thick and be specific to a single saturated zone.

All monitoring wells should be designed and installed in conformance with site hydrogeology, geochemistry, and contaminant(s). While it is not possible to provide specifications for every situation, it is possible to identify certain design components. Figure 7.1 is a schematic drawing of a single-riser/limited interval well. The **casing** provides access to the subsurface. The **intake** consists of a filter pack and screen. The **screen** allows water to enter the well and, at the same time, minimizes the entrance of filter pack materials. The **filter pack** is an envelope of uniform, clean, well-rounded sand or gravel that is placed between the formation and the screen. It helps to prevent sediment from entering the well. Installation of a filter pack and screen may not be necessary for wells completed in competent bedrock. The **annular seal** is emplaced between the borehole wall and the casing and is necessary to prevent vertical movement of ground water and infiltration of surface water and contaminants. **Surface protection**, which includes a surface seal and protective casing, provides an additional safeguard against surface water infiltration and protects the well casing from physical damage.

DESIGN OF MULTIPLE-INTERVAL SYSTEMS

It is often necessary to sample from multiple discrete intervals at a given location if more than one potential pathway exists or a saturated zone is greater than 10 feet thick. Chapter 5 - Monitoring Well Placement discusses the concepts involved in selecting zones to monitor. Multiple-interval monitoring can be accomplished by installing single-riser/limited interval wells in side-by-side boreholes (well clusters) or using systems that allow sampling of more than one interval from the same borehole (multi-level wells, well nests, or single-casing, long-screen wells). Multiple-interval monitoring may be useful to:

- Determine the hydraulic head distribution.
- Measure temporal changes in vertical hydraulic head.
- Determine vertical contaminant distribution.
- Provide long-term multilevel water quality monitoring.

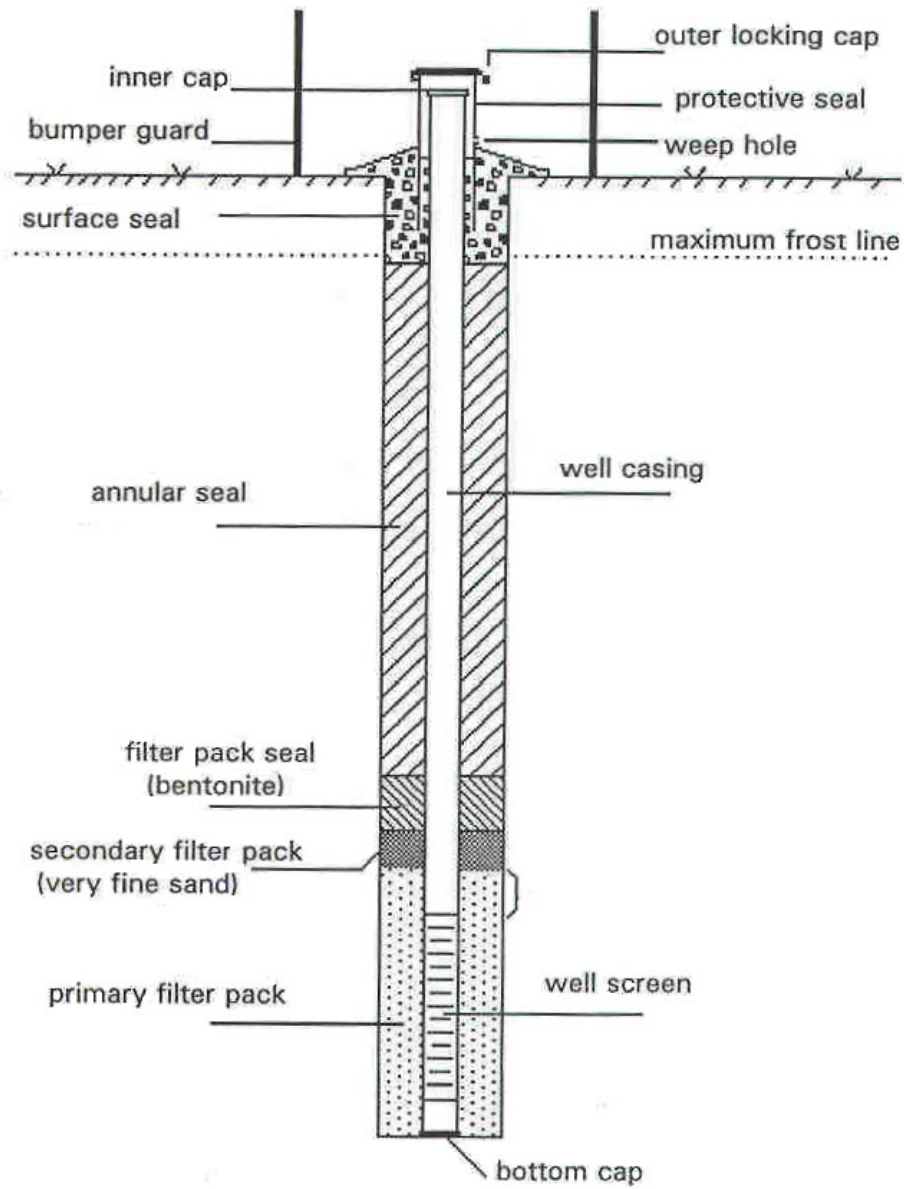

Figure 7.1 Cross-section of a typical single-riser/limited interval monitoring well.

WELL CLUSTERS

When monitoring multiple intervals at one location, single-riser/limited interval wells are often installed in adjacent, separate boreholes. These well clusters can be used to determine vertical gradients when distinct differences in head exist. They may be used to monitor discrete zones or evaluate chemical stratification within a thick zone. If flow direction has been determined prior to installation, the shallow well should be placed hydraulically upgradient of the deeper well to avoid the potential influence on its samples caused by the presence of grout in the annular space of the deeper well.

MULTI-LEVEL WELLS

Multi-level wells allow sampling of more than one interval in a single borehole. These levels are isolated within the well either by packers or grout. Probes, lowered into the casing, can locate, isolate and open a valve into a port coupling to measure the fluid pressure outside the coupling or obtain a sample. Individual tubes run from sampling levels to the surface.

The use of multiple-level monitoring wells in Ohio has been limited due to: 1) cost of installation, 2) difficulty in repairing clogs, and 3) difficulty in preventing and/or evaluating sealant and packer leakage. Detailed workplans (including construction and installation, methods to measure water levels and obtain samples, references to situations where these types of wells have been used successfully, and advantages and disadvantages) should be submitted prior to installing multi-level systems.

Several systems are commercially available for obtaining multi-level monitoring of a single borehole. Most consist of casing or tubing with monitoring ports located at user-selected intervals. In one system, however, a lining containing intermittent sampling ports is placed in the borehole. The systems may be sampled with small diameter pumps and bailers, or using proprietary samplers that go with the monitoring system. See Nielsen and Schalla (2006) for more information on multi-level well systems.

NESTED WELLS

Nested wells involve the completion of a series of single-riser wells in a borehole. Each well is screened to monitor a specific zone, with filter packs and seals employed to isolate the zones. Nested wells are not recommended because they are difficult to install in a manner that ensures that all screens, filter packs, and seals are properly placed and functioning. It is more efficient to install single-riser wells for each interval to ensure that representative samples can be collected. Aller et al. (1991) indicated that individual completions generally are more economical at depths less than 80 feet. According to Nielsen and Schalla (2006), the cost of installing well clusters is comparable to the cost for nested wells. Well clusters can enable savings on sampling and future legal costs that may be necessary to prove the accuracy of nested wells.

SINGLE-CASING, LONG-SCREEN WELLS

Single-casing, long-screen wells are monitoring wells that, in general, are screened across the entire thickness of a water-bearing zone. If purging is performed immediately before sampling, only composite water samples are yielded, which are not adequate for most monitoring studies. If natural, flow-through conditions can be maintained, vertical water quality profiles can be obtained with passive sampling techniques. Vertical profiling may be a cost effective initial assessment to determine the depth of final wells.

Long-screen wells are not appropriate for detection monitoring. Furthermore, these wells can allow cross-contamination between different zones and, therefore, should not be used in contaminated areas.

CASING

The purpose of casing is to provide access to the subsurface for sampling of ground water and measurement of water levels. A variety of casing types have been developed. Items that must be considered during well design include casing type, coupling mechanism, diameter, and installation.

CASING TYPES

Three categories of casing are commonly used for ground water monitoring, including fluoropolymers, metallics, and thermoplastics (Aller et al., 1991). All have distinctive characteristics that determine their appropriateness.

Fluoropolymers

Fluoropolymers are synthetic plastics composed of organic material. They are resistant to chemical and biological attack, oxidation, weathering, and ultraviolet (UV) radiation. They have a broad useful temperature range, a high dielectric constant, a low coefficient of friction, display anti-stick properties, and have a greater coefficient of thermal expansion than most other plastics and materials (Aller et al., 1991). Standard properties of the various materials have been provided by Aller et al. (1991).

The most common fluoropolymer used for monitoring wells is polytetrafluoroethylene (PTFE). It can withstand strong acids and organic solvents and, therefore, it is useful for environments characterized by the presence of these chemicals. It maintains a low tensile strength, which theoretically limits installation of Schedule 40 PTFE to an approximate depth of 250 ft¹. It is also very flexible, which makes it difficult to install with the retention of straightness that is needed to ensure successful insertion of sampling or measurement devices. Dablow et al. (1988) found that the ductile nature of PTFE can result in the partial closing of screen slots

¹ The maximum depth for PTFE casing depends on site hydrogeology. If the casing largely penetrates unsaturated soils, the depth may be limited to approximately 100 feet. However, if the casing is placed mostly in water-bearing zones, then depth may be as great as 375 feet.

due to the compressive forces of the casing weight. This makes slot size selection very difficult. PTFE is costly, generally ten times more expensive than thermoplastics. Studies by Gillham and O'Hannesin (1990), Parker et al. (1990), and Parker and Raney (1993) (in Nielsen and Schalla, 2006), found that PTFE showed higher sorption rates than PVC of organic compounds. These studies concluded that PVC was a better material to use when organics are present.

Metallics

Metallic materials include low carbon, carbon, galvanized, and stainless steel. Metallics are very strong and rigid and can be used to virtually unlimited depths. Corrosion problems are the major disadvantage for low carbon, carbon, and galvanized casings, as electrochemical and chemical attack alters water sample quality. U.S.EPA (1992) has listed the following as indicators of corrosive conditions (modified from Driscoll, 1986):

- Low pH (< 7.0).
- Dissolved oxygen exceeds 2 ppm.
- Hydrogen sulfide in quantities as low as 1 ppm.
- Total dissolved solids (TDS) greater than 1000 ppm.
- Carbon dioxide exceeds 50 ppm.
- Chloride (Cl⁻), bromide (Br⁻), and fluoride (F⁻) content together exceeds 500 ppm.

According to Barcelona et al. (1983), flushing before sampling does not minimize the bias of low carbon steel due to the inability to predict the effects of disturbed surface coatings and corrosion products accumulated at the bottom of the well. Due to their high corrosion potential, all metallics except stainless steel are unacceptable for monitoring wells.

Stainless steel is manufactured in two common types, 304 and 316. Type 304 is composed of iron with chromium and nickel. Type 316's composition is the same as Type 304's, but includes molybdenum, which provides further resistance to sulfuric acid solutions. Stainless steel is readily available in a wide variety of diameters.

Stainless steel can perform quite well in most corrosive environments. In fact, oxygen contact develops an external layer that enhances corrosion resistance (Driscoll, 1986). However, several studies cite the formation of an iron oxide coating on the surface of stainless steel casing that forms in long-term exposure to ground water that can have unpredictable effects on the adsorption capacity of the casing material (Nielsen and Schalla, 2006). Under very corrosive conditions, stainless steel can corrode and release nickel and chromium into ground water samples (Barcelona et al., 1983). Combinations and/or extremes of the factors indicating corrosive conditions generally are an indication of highly corrosive environments. For example, Parker et al. (1990) found that both 304 and 316 showed rapid rusting (<24 hrs.) when exposed to water containing chloride above 1000 mg/l, and a study by Oakley and Korte (in Nielsen and Schalla, 2006) noted corrosion of stainless steel at even lower chloride levels (600-900 mg/L). Like PTFE, stainless steel is relatively expensive in comparison with thermoplastics. Nielsen and Schalla (2006) and Aller et al. (1991) provided additional information on the properties of stainless steel.

Thermoplastics

Thermoplastics are composed of large, synthetic organic molecules. The most common type used for monitoring wells is polyvinyl chloride (PVC), while a material used less often is acrylonitrile butadiene styrene (ABS). These materials are weaker, less rigid, and more temperature-sensitive than metallics. Thermoplastics are very popular due to their light weight, high strength to weight ratio, low maintenance, ease of joining, and low cost.

Common, acceptable PVC types are Schedule 40 and Schedule 80. The greater wall thickness of Schedule 80 piping enhances durability and strength, provides greater resistance to heat attack from cement, and allows construction of deeper wells. Only rigid PVC should be used for monitoring wells. Flexible PVC is composed of a high percentage of plasticizers (30 - 50%), which tend to degrade and contaminate samples (Jones and Miller, 1988). All PVC casing should meet Standard 14 of NSF International. This standard sets control levels for the amount of chemical additives to minimize leaching of contaminants (NSF International, 1988). Additional specifications have been provided by Nielsen and Schalla (2006) and Aller et al. (1991).

Drawbacks of PVC include brittleness caused by ultraviolet (UV) radiation, low tensile strength, relative buoyancy in water, and susceptibility to chemical attack. It is immune to corrosion and is resistant to most acids, oxidizing agents, salts, alkalies, oils, and fuels (NWWA/PPI, 1981). Additionally, Schmidt (1987) showed that no degradation of PVC occurred after six months immersion in common gasolines. However, studies have shown that high concentrations (parts-per-thousand or percentage concentrations) of tetrahydrofuran, methyl ethyl ketone, methyl isobutyl ketone, and cyclohexane degrade PVC (Nielsen and Schalla, 2006). Barcelona et al. (1983) reported that low molecular weight ketones, aldehydes, amines, and chlorinated alkenes and alkanes may cause degradation. Studies by Ranney and Parker (1995, 1997) and Parker and Ranney (1994b, 1995, 1996), showed that PVC is degraded when exposed to higher concentrations (0.2 and 0.4, or 20% and 40% of the solubility limit of the solvent in water) of aromatic hydrocarbons, aromatic and aliphatic chlorinated solvents, ketones, anilines, aldehydes and nitrogen-containing organic compounds. It is recommended that PVC not be used in situations where the material may be exposed to concentrations of known solvents or swelling agents of PVC greater than 25% of the solubility limit of the solvent or swelling agent (Nielsen and Schalla, 2006).

TYPE SELECTION

Many regulated parties choose PVC casing because of its lower cost; however, well integrity and sample representativeness are more important criteria. The high cost of analysis and the extreme precision of laboratory instruments necessitate the installation of wells that produce representative samples. Above all, the burden of proof is on the regulated party to demonstrate that casing is appropriate. The proper selection can be made by considering casing characteristics in conjunction with site conditions.

Casing characteristics include strength, chemical resistance, and chemical interference potential. The **strength** must withstand the extensive tensile, compressive, and collapsing forces involved in maintaining an open borehole. Since the forces exerted are, in large part,

related to well depth, strength often is important when planned depth exceeds the maximum range of the weakest acceptable material (100 to 375 ft. - PTFE). In these instances, either stainless steel or PVC should be chosen. Strength can be the overriding factor because the concern for chemical resistance and interference become insignificant if an open borehole cannot be maintained. Nielsen and Schalla (2006) provided specific strength data for commonly used materials.

The casing also must withstand **electrochemical corrosion and chemical attack** from natural ground water and any contaminant(s). Chemical resistance is most important in highly corrosive environments, when contaminants are present at extremely high levels, and when wells are intended to be part of a long-term monitoring program. For extended monitoring in corrosive environments, PTFE and PVC are preferred over stainless steel because of the potential for the metallic material to degrade. If high concentrations of organics (parts per thousand) are present, either PTFE or stainless steel should be selected. PVC should not be used if a PVC solvent/softening agent is present or the aqueous concentration of a solvent/softening agent exceeds 25% of its solubility in water. It is suitable in most situations where low (parts per billion to low parts per million) levels of most organic constituents are present (Nielsen and Schalla, 2006).

The casing also should not interfere with sample quality by **adding (leaching) or removing contaminants**. In most cases, the magnitude of this interference is a function of the ground water's contact time with the casing. The longer the contact, the greater the potential for leaching and sorption. Various studies have been conducted [Barcelona and Helfrich (1988), Curran and Tomson (1983), Gillham and O'Hannesin (1990), Jones and Miller (1988), Miller (1982), Parker and Jenkins (1986), Parker et al. (1990), Reynolds and Gillham (1985), Schmidt (1987), Sykes et al. (1986), Tomson et al. (1979), Hewitt (1992, 1994), Parker and Ranney (1994)] to compare the sorbing and leaching characteristics of the three favored materials. No conclusive results have been obtained to indicate that any one is best. Most of these studies involved contact lasting days, weeks, and even months and, therefore, the results cannot be correlated to field conditions where contact is often minimal because sampling is generally conducted soon after purging.

In many cases, concern about sorption or leaching may be exaggerated. Barcelona et al. (1983) and Reynolds and Gillham (1985) both concluded that the potential sorption biases for casing may be discounted due to the short contact after purging. Also, Parker et al. (1990) indicated that sorption of various constituents never exceeded 10 percent in the first 8 hours of their tests. They concluded that, on the basis of overall sorption potential for organic and inorganic compounds, PVC is the best compromise.

In summary, the appropriate casing should be determined on a case-by-case basis. PVC is acceptable when free product is not present and the solubility limits of organic contaminants are not approached (e.g., levels that exceed 0.25 times the solubility). Ohio EPA recognizes the difficulty inherent in establishing a "cut-off" level for when aqueous concentrations of organics cause failure of PVC. To be certain that casing will retain integrity, particularly when monitoring is planned for long periods of time (e.g., 30 years), Ohio EPA may recommend a more resistant casing when aqueous concentrations are relatively high but still below the criteria mentioned above.

HYBRID WELLS

Casing not in contact with the saturated zone generally is not subject to attack. Therefore, it may be possible to install less chemically resistant material above the highest seasonal water level and more inert material where ground water continually contacts the casing. Such a "hybrid well" commonly is installed to reduce costs. For example, when monitoring a zone with high concentrations of organics, stainless steel could be installed opposite the saturated materials, while PVC could be used opposite the unsaturated materials. Thus, resistant, more expensive casing would be present where contact with highly contaminated ground water may occur, while less resistant, inexpensive casing would be present where contact does not occur.

Variations in ground water levels caused by seasonal or pumping effects should be taken into account when planning the casing material configuration (Nielsen and Schalla, 2006). Different varieties of steel never should be installed in the same well. Each type is characterized by its own electro-chemical properties. Installation of different types in contact can increase the potential for corrosion.

COUPLING MECHANISMS

Casing sections should be connected using threaded joints that provide for uniform inner and outer diameters along the entire length of the well. Such "flush" coupling is necessary to accommodate tools and sampling devices without obstruction and to help prevent bridging during the installation of the filter pack and annular seal. It should be noted that thread types vary between manufacturers and matching can be difficult. A union among non-matching joints should never be forced, otherwise structural integrity of the joint and the entire well could be compromised. To alleviate these problems, the American Society of Testing and Materials has developed Standard F 480-90 (1992) to create a uniformly manufactured flush-threaded joint. Most manufacturers now produce the F 480 joint, which is available in both PVC and stainless steel.

Solvent cements should never be used because they are known to leach organics. Metal fasteners such as rivets or screws should not be used to supplement threaded joints. Use of such fasteners can reduce the effective inner well diameter, and may damage pumps or other tools lowered into the well (Nielsen and Schalla, 2006).

It is recommended that either nitrile, ethylene propylene, or Viton O-rings be used between sections to prevent the seal and/or affected water from entering (Nielsen and Schalla, 2006). Nielsen and Schalla (2006) indicated that Teflon tape can be used in place of O-rings, although it does not ensure as good a seal. Although welding stainless steel can produce a flush joint that is of equal or greater strength than the casing itself, this method is not used as commonly as threaded joints due to the extra assembly time, welding difficulty, corrosion enhancement, ignition danger, and the potential to lose materials into the well (Nielsen and Schalla, 2006). Threaded steel casing provides inexpensive, convenient connections. It should be noted that threaded joints reduce the tensile strength of the casing; however, this does not cause a problem for most shallow wells. Also, threaded joints may limit or hinder the use of various sampling devices when thin-walled stainless steel (Schedules 5 and 10) is

employed. Thin-walled casing is too thin for threads to be machined, so the factory welds a short, threaded section of Schedule 40 stainless steel pipe to the end of the thin-walled pipe. These joints are made to be flush on the outside, but not the inside.

If hybrid wells are installed, it is essential that the joint threads be matched properly. This can be accomplished by purchasing casing screen that is manufactured to ASTM F480-90 (1992) standard coupling.

DIAMETER

Choice of casing diameter is site-specific. Small wells are considered to be less than 4 inches in diameter. Wells installed using conventional drilling methods are generally 2 or 4 inches in diameter. Wells installed by direct push technologies (see Chapter 15 – Use of Direct Push Technologies for Soil and Ground Water Sampling) have diameters of 2 inches to as small as 0.5 inch. Advantages of small diameter wells are as follows:

- Water levels require less time to recover after purging.
- They produce a smaller volume of purged water that must be disposed.
- Construction costs are lower.
- They are more easily installed by driven, direct push, jetting, or hollow stem augers.

Some disadvantages of small diameter wells include:

- Access may be limited for sampling devices.
- Filter packs and seals are more difficult to install.
- They offer a lower depth capability due to lesser wall thickness.
- Development can be more difficult.
- Less ground water is pumped during a hydraulic test or a remediation extraction.
- The amount of available water may be too small for chemical analyses.
- Slower recovery after water removal.

CASING INSTALLATION

Casing should be cleaned thoroughly before installation. Strong detergents and even steam cleaning may be necessary to remove oils, cleansing solvents, lubricants, waxes, and other substances (Curran and Tomson, 1983; Barcelona et al., 1983). It is strongly recommended that only factory-cleaned materials be used for monitoring wells. Casing can be certified by the supplier and individually wrapped in sections to retain cleanliness. If it has not been factory-cleaned and sealed, it should be washed thoroughly with a non-phosphate, laboratory grade detergent (e.g., Liquinox) and rinsed with clean water or distilled/deionized water as suggested by Curran and Tomson (1983) and Barcelona et al. (1983). The materials should be stored in a clean, protected place to prevent contamination by drilling and site activities.

When installing casing, it is important that it remain centered in the borehole to ensure proper placement and even distribution of the filter pack and annular seal. In addition, centering helps ensure straightness for sampling device access. If a hollow-stem auger is used, no additional measures are necessary because the auger acts as a centralizing device. If

casing is installed in an open borehole, centralizers made of stainless steel or PVC can be used. They are adjustable and generally attached just above the screen and at 10 to 20 foot intervals along the riser. If centralizers are used, measures should be taken to prevent them from bridging the filter pack and seal material during their installation.

If the well screen and riser are significantly lighter than the buoyant force of the fluid in the borehole, the casing assembly may require ballast to offset the tendency of the materials to float in the borehole. The riser may be ballasted by filling it with water of a known and acceptable source or with water previously removed from the borehole. Alternatively, hydraulic rams on the drill rig may be used to push the riser into the borehole (ASTM D5092-04).

INTAKES

Although every well is unique, most have a screen and filter pack comprising the well intake. Monitoring wells in cohesive bedrock may incorporate open borehole intakes.

FILTER PACK

Wells monitoring unconsolidated and some poorly consolidated materials typically need to have a screen (discussed later) surrounded by more hydraulically conductive material (filter pack). In essence, the filter pack increases the effective well diameter and prevents fine-grained material from entering.

Types of Filter Packs

Filter packs can be classified by two major categories, natural and artificial. **Natural packs** are created by allowing the formation to collapse around the screen. In general, natural packs are recommended for formations that are coarse-grained, permeable, and uniform in grain size. Grain size distribution of the formation should be determined through a sieve analysis of samples from the formation. According to Nielsen and Schalla (2006), natural packs may be suitable when the effective grain size (sieve size that retains 90%, or passes 10%) is greater than 0.010 inch and the uniformity coefficient (the ratio of the sieve size that retains 40% and the size that retains 90%) is greater than 3. Ideally, all fine-grained particles are removed when the well is developed, leaving the natural pack as a filter to the surrounding formation.

Installation of **artificial packs** involves the direct placement of coarser-grained material around the screen. The presence of this filter allows the use of a larger slot size than if the screen were in direct contact with the formation. Artificial packs generally are necessary where: 1) the formation is poorly sorted; 2) the intake spans several formations and/or thin, highly stratified materials with diverse grain sizes; 3) the formation is a uniform fine sand, silt or clay; 4) the formation consists of thinly-bedded materials, poorly cemented sandstones, and highly weathered, fractured, and solution-channeled bedrock; 5) shales and coals that provide a constant source of turbidity are monitored; and 6) the borehole diameter is significantly greater than the diameter of the screen (Aller et al., 1991), (Nielsen and Schalla, 2006). Artificial packs generally are used opposite unconsolidated materials when the

effective grain size is less than 0.010 inches and when the uniformity coefficient is less than 3.0 (Nielsen and Schalla, 2006). Pre-packed well screens (discussed below) may also be used to install an artificial filter pack. The filter pack for these screens is installed at the surface, ensuring an effective filter pack.

An artificial pack may include two components. The **primary pack** extends from the bottom of the borehole to above the top of the screen. In some cases, it may be desirable to place a **secondary pack** directly on top of the primary pack. Its purpose is to prevent the infiltration of the annular seal into the primary pack, which can partially or totally seal the screen.

Nature of Artificial Filter Pack Material

The artificial pack material should be well-sorted, well-rounded, clean, chemically inert, of known origin, and free of all fine-grained clays, particles and organic material. Barcelona et al. (1983) recommended clean quartz sand or glass beads. Quartz is the best natural material due to its non-reactive properties and availability. Crushed limestone should never be used because of the irregular particle size and potential chemical effects. Materials should be washed, dried, and packaged at the factory, and typically are available in 100 lb. bags (approximately one cubic foot of material) (Nielsen and Schalla, 2006).

The material should be based on the formation particle size. If chosen grains are too small, it is possible that loss of the pack to the formation can occur (Nielsen and Schalla, 2006), which could lead to the settling of the annular seal into the screened interval. On the other hand, if the grains are too large, the pack will not effectively filter fine-grained material, leading to excessively turbid samples. For these reasons, the universal application of a single well screen/filter pack combination to all formations should be avoided (ASTM D5092-04).

The primary pack generally should range in grain size from a medium sand to a cobbled gravel. Most materials are available in ranges, such as 20- to 40-mesh (0.033 to 0.016 inches, Table 7.1). The grain size of the primary filter pack should be determined by multiplying the 70% retention size of the formation by a factor of 3 to 6 (U.S. EPA, 1975). A factor of 3 is used for fine, uniform formations; a factor of 6 is used for coarse, non-uniform formations. Where the material is less uniform and the uniformity coefficient ranges from 6 to 10, it may be necessary to use the 90% retention (10% passing) size multiplied by 6 (Nielsen and Schalla, 2006). This is to ensure that the bulk of the formation will be retained. The ratio of the particle size to the formation grain size should not exceed 6, otherwise, the pack will become clogged with fine-grained material from the formation (Lehr et al., 1988). If the ratio is less than 4, a smaller screen slot size will be necessary, full development of the well may not be possible, and well yield may be inhibited. When monitoring in very heterogeneous, layered stratigraphy, a type of pack should be chosen that suits the layer with the smallest grain size.

It is preferred that the filter pack be of uniform grain size. Ideally, the uniformity coefficient should be as close to 1.0 as possible and should not exceed 2.5 (Nielsen and Schalla, 2006, ASTM D5092-04, 2005). Uniform material is much easier to install. If non-uniform material is used, differing fall velocities cause the materials to grade from coarse to fine upwards along the screen. This can result in the loss of the upper fine-grained portion to the well during development.

The secondary filter pack material should consist of a 90% retention sieve size (10% passing) that is larger than the voids of the primary pack to prevent the secondary pack from entering the primary pack (Nielsen and Schalla, 2006). In general, the secondary 90% retention size should be one-third to one-fifth of the primary 90% retention size (Nielsen and Schalla, 2006).

Dimension of Artificial Filter Pack

The filter pack should be thick enough to completely surround the well screen. The well annulus should be large enough to preclude bridging of the filter-pack material. Centering of the well screen in the borehole will ensure adequate space for an effective filter pack. Driscoll (1986) states that the mechanical filtration function of the filter pack can be achieved with a filter pack of only 2 to 3 grains in thickness. Filter packs of less than a half inch thick have been successfully used in pre-packed well screens that are installed in direct push boreholes (Nielsen and Schalla, 2006).

The primary pack should extend from the bottom of the screen to at least 3 feet above its top (Nielsen and Schalla, 2006). In deeper wells (i.e., >200 feet), the pack may not compress initially. Compression may occur after installation of the annular seal, which may allow the seal to be in close contact with the screen. Therefore, additional pack material may be needed to account for settling and, at the same time, provides adequate separation of the seal and the screen. However, extension of the pack should not be excessive because it enlarges the zone that contributes ground water to the well, which may cause excess dilution. The length of the secondary pack should be 1 foot or less.

Artificial Filter Pack Installation

Methods that have been used for artificial pack installation include tremie pipe, gravity emplacement, reverse circulation, and backwashing (Nielsen and Schalla, 2006). The material should be placed in a manner that prevents bridging and particle segregation. Bridging can cause large voids and may prevent material from reaching the intended depth. Segregation can cause a well to produce turbid samples. During installation, regular measurements with a weighted tape should be conducted to determine when the desired height has been reached, and also act as a tamping device to reduce bridging. The anticipated volume of filter pack should be calculated.² Any discrepancy between the actual and calculated volumes should be explained.

² Anticipated filter pack volume can be calculated by determining the difference in volume between the borehole and casing (using outside diameter of the well) from the bottom of the borehole to the appropriate height above the well screen.

Table 7.1 Common filter pack characteristics for typical screen slot sizes (From Nielsen and Schalla, 2006).

Size of Screen Opening [mm (in.)]	Slot No.	Sand Pack Mesh Size	1% Passing Size (D ₁) (mm)	Effective Size (D ₁₀) (mm)	30% Passing Size (D ₃₀) (mm)	Range of Uniformity Coefficient	Roundness (Powers Scale)	Fall Velocities ^a (cm/s)
0.125(0.005)	5	40-140	0.09-0.12	0.14-0.17	0.17-0.21	1.3-2.0	2-5	6-3
0.25 (0/010)	10	20-40	0.25-0.35	0.4-0.5	0.5-0.6	1.1-1.6	3-5	6-6
0.50 (0.020)	20	10-20	0.7-0.9	1.0-1.2	1.2-1.5	1.1-1.6	3-6	14-9
0.75 (0.030)	30	10-20	0.7-0.9	1.0-1.2	1.2-1.5	1.1-1.6	3-6	14-9
1.0 (0.040)	40	8-12	1.2-1.4	1.6-1.8	1.7-2.0	1.1-1.6	4-6	16-13
1.5 (0.060)	60	6-9	1.5-1.8	2.3-2.8	2.5-3.0	1.1-1.7	4-6	18-15
2.0 (0.080)	80	4-8	2.0-2.4	2.4-3.0	2.6-3.1	1.1-1.7	4-6	22-16

^a Fall velocities in centimeters per second are approximate for the range of sand pack mesh sizes named in this table . If water in the annular space is very turbid, fall velocities may be less than half the values shown here. If a viscous drilling mud remains in the annulus, fine particles may require hours to settle.

The preferred method for artificial pack installation is to use a **tremie pipe** to emplace material directly around the screen (Figure 7.2). The pipe is raised periodically to help minimize bridging. The pipe generally should be at least 1 inch ID, but larger diameters may be necessary where coarser-grained packs are being installed. When driven casing or hollow-stem augering is used to penetrate non-cohesive formations, the material should be tremied as the casing and auger is pulled back in one to two foot increments to reduce caving effects and ensure proper placement (Nielsen and Schalla, 2006). When installing wells through cohesive formations, the tremie pipe can be used after removal of the drilling device.

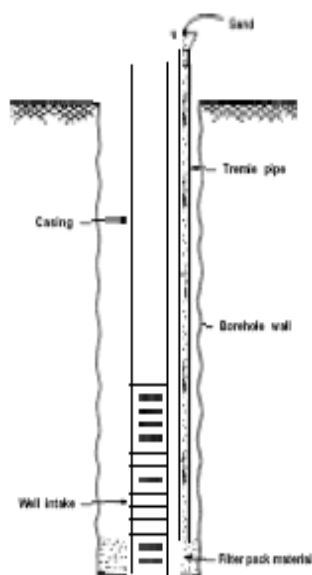

Figure 7.2. Installation of artificial filter pack material with a tremie pipe. (Source: Aller et al., 1991).

Gravity emplacement is accomplished by allowing material to free-fall to the desired position around the screen. Placement by gravity should be restricted to shallow wells with an annular space greater than 2 inches, where the potential for bridging or segregation is minimized (Nielsen and Schalla, 2006). For low-yielding formations, it may be possible to bail the borehole dry to facilitate placement; however, segregation is generally not a problem if the pack has a uniformity coefficient of 2.5 or less. Gravity placement also can cause grading if the material is not uniform. In addition, formation materials are often incorporated during placement, which can contaminate the pack and reduce its effectiveness. For most cases, gravity placement is not recommended.

Reverse circulation involves the insertion of a sand and water mixture through the annulus. Sand is deposited around the screen as the water returns to the surface through the casing. Due to the potential water quality alteration, this method generally is not recommended.

Sand is deposited around the screen as the water returns to the surface through the casing. Due to the potential water quality alteration, this method generally is not recommended.

Backwashing is accomplished by allowing material to free-fall through the annulus while clean water is pumped down the casing. The water returns up the annulus carrying fine-grained material with it. This creates a more uniform pack; however, the method is not commonly used for monitoring well installation and generally is not recommended due to the potential for alteration of ground water quality. Nonetheless, it is sometimes used for placing packs opposite non-cohesive heaving sands and silts.

SCREEN

The screen provides an access point to a specific portion of a ground water zone, as well as providing a barrier to keep unwanted formation particles out of ground water samples.

Screen Types

Recommended screen compositions are stainless steel, PTFE, and PVC. The same discussion and concerns for casing materials apply to screens. Only manufactured screens should be used, since these are available with slots sized precisely for specific grain sizes. Field-cut or punctured screen should never be used, due to the inability to produce the necessary slot size and the potential for the fresh surface to leach or sorb contaminants. A bottom cap or plug should be placed at the base of the screen to prevent sediments from entering and to ensure that all water enters the well through the screen openings.

Slotted and continuous slot, wire-wound screen are the common types used for monitoring wells. In deep wells, slotted screen generally retains structural integrity better than wire-wound; however, continuous slot, wire-wound screens provide almost twice the open area of slotted casing. More open area per unit length enhances well recovery and development. A slot type should be chosen that provides the maximum amount of open area in relation to the effective porosity of the formation. Opinions vary regarding the optimum percentage of open area needed for effective hydraulic performance of well screens. Though it has been suggested that a range of open areas from 8 to 38% do not differ significantly in well performance, Driscoll (1986) recommended that the percentage of open area should be at least equal to the effective porosity of the formation and filter pack. In common situations

with 8 to 30 percent effective porosities, continuous slot screens are preferred, although not required. A high percentage of open area is of greater importance when wells are installed in fine-grained formations where smaller slot sizes and fine-grained filter packs are required (Nielsen and Schalla, 2006).

Pre-Packed Screen Wells

A pre-packed screen is an assembly consisting of an inner slotted screen surrounded by a wire mesh sleeve that acts as a support for filter media. The pre-packed screen assemblies can either be shipped with filter media already packed within the mesh sleeve or can be shipped without filter media and packed with filter sand in the field. Refer to ASTM D5092-04 for appropriate sizing of filter pack material. Pre-packed well screens help eliminate problems in the placement of filter pack around the screens of small diameter wells. In fine-grained formations pre-packed screens may be best for ensuring proper filter pack placement.

(ASTM D5092-04). The wells are sealed and grouted using the same procedure described for conventionally completed DPT wells. ASTM D6725-04 provides additional guidance on the use of pre-packed wells.

Slot Size

When selecting a screen slot size for an artificially filter-packed well, a sieve analysis should be conducted on the pack material. The selected size should retain at least 90% of the pack. In many situations it is preferable to retain 99% (Nielsen and Schalla, 2006 and ASTM D 5092-90, 1994). See Table 7.1 for a guide to the selection of slot sizes for various packs.

For naturally-packed wells, the screen should retain at least 70% of the pack (Nielsen and Schalla, 2006, ASTM D5092-04). For additional information on pack and screen selection, see Aller et al. (1991), Nielsen and Schalla, (2006), and ASTM D 5092-90 (1994).

It should be noted that if a PTFE screen is used in a deep well, a slightly larger slot size than predicted should be selected due to the material's lower compressive strength, which allows the openings to compress (Dablow et al., 1988).

Length

Screen length should be tailored to the desired zone and generally should not exceed 10 ft. A 2 to 5 ft. screen is desirable for more accurate sampling and discrete head measurements. Longer screens produce composite samples that may be diluted by uncontaminated water. As a result, concentrations of contaminants may be underestimated. In addition, if vertical flow is present, the well screen may provide a pathway for redistribution of contaminants, and possible cross-contamination of the formation (Nielsen and Schalla, 2006). Furthermore, the screen should not extend through more than one water-bearing zone to avoid cross-contamination. When a thick formation must be monitored, a cluster of individual, closely spaced wells, screened at various depths, can be installed to monitor the entire formation thickness. The length of screens that monitor the water table surface should account for seasonal fluctuation of the water table. For related information on screen length, refer to Chapter 5 – Monitoring Well Placement.

OPEN BOREHOLE INTAKES

When constructing monitoring wells in competent bedrock, an artificial intake is often unnecessary because an open hole can be maintained and sediment movement is limited. Installing a filter pack in these situations may be difficult due to loss of material into the surrounding formation. In some cases, however, intakes are a necessary component of bedrock wells. A screen and filter pack should be installed in highly weathered, poorly cemented, and fractured bedrock (Nielsen and Schalla, 2006). They are usually necessary when monitoring the unconsolidated/consolidated interface in Ohio.

Open hole wells often are completed by casing and grouting the annulus prior to drilling into the monitoring zone. In cases where the zone has been drilled prior to sealing the annulus, a bridge (cement basket or formation packer shoe) must be set in the hole to retain the grout/slurry to the desired depth (Driscoll, 1986).

If an open hole well is installed, the length of open hole generally should not exceed 10 feet to prevent sample dilution. To maintain a discrete monitoring zone in consolidated formations, the casing should be extended and grouted to the appropriate depth to maintain the 10 foot limit. Driven casing may be necessary to avoid loss of the annular seal into the surrounding formation.

ANNULAR SEALS

The open, annular space between the borehole wall and the casing must be sealed properly to: 1) isolate a discrete zone, 2) prevent migration of surface water, 3) prevent vertical migration of ground water between strata, and 4) preserve confining conditions by preventing the upward migration of water along the casing. An effective seal requires that the annulus be filled completely with sealant and the physical integrity of the seal be maintained throughout the lifetime of the well (Aller et al., 1991).

MATERIALS

The sealant must be of very low permeability (generally 10^{-7} to 10^{-9} cm/sec), capable of bonding with casing, and chemically inert with the highest anticipated concentration of chemicals expected. Cuttings from the existing borehole, no matter what the type of materials, should never be used. They generally exhibit higher permeability and cannot form an adequate seal. The most common materials used are bentonite and neat cement grout. Each has specific, unique, and desirable properties. These materials are discussed briefly here. Additional information can be found in Michigan DEQ (2007), ASTM Method C-150 (2007), and Nielsen and Schalla (2006).

Bentonite

Bentonite is composed of clay particles that expand many times their original volume when hydrated. The most acceptable form is a sodium (Na) rich montmorillonite clay that exhibits a 10- to 12-fold expansion when hydrated. Other types, such as calcium (Ca) bentonite, are less desirable because they offer lower swelling ability and surface area to mass ratios. However, other types should be considered if Na bentonite is incompatible with the formation or analyses of concern. For example, the capability of bentonite may be adversely affected by chloride salts, acids, alcohols, ketones, and other polar compounds. Ca bentonite may be more appropriate for calcareous sediments.

Bentonite is available in a variety of forms, including pelletized, coarse grade, granular and powder. **Pellets** are uniform in size and consist of compressed, powdered Na montmorillonite. They typically range from 1/4 to 1/2 inch in size. Pellets expand at a relatively slower rate when compared to other forms. **Coarse grade**, also referred to as crushed or chipped, consists of irregularly shaped, angular particles of montmorillonite that range from 1/4 to 3/4 inches in size. **Granular** particles range from 0.025 to 0.10 inches in size. **Powdered** bentonite is pulverized montmorillonite, factory-processed after mining. Powdered and granular forms are generally mixed with water to form a slurry.

Risk of losing a slurry to the underlying filter pack and surrounding formation should be considered. Bentonite slurry with less than 30 percent solids can lose its affinity for water, thus losing water to the formation (Listi, 1993). Bentonite used for drilling fluids/drilling fluid mud has a low solids content and therefore forms poor seals, so they are not suitable as annular seal materials (Edil et al., 1992). High-solids bentonite (>30% clay solids) has been developed specifically for monitoring well construction and provides an effective seal. High-solids bentonite slurries may also be formed by the addition of a swelling inhibitor to slow the swelling of the bentonite powder, or addition of granular bentonite to bentonite slurry just prior to emplacement with a tremie pipe (Nielsen and Schalla, 2006).

Neat Cement Grout

Neat cement grout is comprised of portland cement and water, with no aggregates added. It is a hydraulic cement produced by pulverizing cement clinker consisting essentially of hydrated calcium silicates, and usually containing one or more forms of calcium sulfate as an interground addition. Several types of portland cements are manufactured to accommodate various conditions. Table 7.2 lists the types as classified by ASTM C150-07(2007). Type I is most commonly used for monitoring wells.

Air-entraining portland cements have been specially processed to form minute air bubbles within the hardened structure. The air-entraining materials are added during the grinding of the clinker. The finished product is more resistant to freeze-thaw action. Air-entraining cements are designated with an "A" after the ASTM cement type. They have been used to construct water supply wells; however, they are less desirable than standard cements because of their greater permeability. Therefore, air-entraining varieties are not recommended for subsurface sealing of monitoring wells.

Water added to the neat cement should be potable and contain less than 500 ppm total dissolved solids (Nielsen and Schalla, 2006). Low chloride and sulfate concentrations also are desirable (Campbell and Lehr, 1973). As the water to cement ratio increases, the compressive strength of the cement decreases and shrinkage increases. The American Petroleum Institute recommends a ratio of 5.2 gallons of water per 94 pound sack of cement. Additional water makes it easier to pump, but adversely affects the grout's sealing properties. Excess water can cause shrinkage and separation of the cement particles, which compromises seal integrity (Nielsen and Schalla, 2006).

Table 7.2 ASTM cement designation (modified from Michigan DEQ, 2007).

CEMENT TYPE	DESCRIPTION
Type I	General purpose cement suitable where special properties are not required. Most common type of cement used for grouting.
Type II	Moderate sulfate resistance. Lower heat of hydration than Type I.
Type III	High early strength. Not commonly used. Ground to finer particle size, which increases surface area and reduces curing time period before drilling may resume from 48 hours to 12 hours.
Type IV	Low heat of hydration cement designated for applications where the rate and amount of heat generated by the cement must be kept to a minimum. Develops strength at a lower rate than Type I. Not commonly used.
Type V	Sulfate-resistant cement for use where ground water has a high sulfate content.
Type IA, IIA, and IIIA	Air entraining cements for the same use as Types I, II, and III. Not recommended for monitoring well construction.

The major disadvantages of neat cement are its heat of hydration, shrinkage upon curing, and its effect on water quality. During curing, heat is released, which is generally of little concern for monitoring wells. If large volumes of cement are used or the heat is not rapidly dissipated, the resulting high temperatures can compromise the integrity of PVC casing. However, the borehole for most monitoring wells is small, and heat significant enough to cause damage generally is not created.

Shrinkage is undesirable because it causes cracks and voids. Bentonite is sometimes added to cement slurry to reduce shrinkage, the bentonite causing the mixture to expand as it hydrates and swells. Bentonite is also added to improve the cement's workability, reduce the

weight and density of the slurry, and reduce the set strength of the cement seal. Several authors, however, have shown bentonite to be chemically incompatible with cement so that the bentonite does not swell, and indeed reduces the capacity of the slurry to swell (Calhoun, 1988, Listi, 1993). Sodium ions in the bentonite are replaced by calcium ions in the cement through ion exchange, reducing the capacity of the bentonite to swell. Cement also releases OH⁻ ions as it sets, which causes the bentonite to flocculate, reducing its swelling ability. Christman et. al (2002) found that cement-bentonite grout showed evidence of dryness and variable consistency. If used, cement-bentonite grout should be used with care (ASTM 5092-04, Cristman, et. al, 2002).

Upon setting, neat cement grouts often lose water into the formation and affect water quality. Neat cement typically ranges in pH from 10 to 12; therefore, it is important to isolate the annular seal from the screen and filter pack. This may be accomplished by placing a very fine-grained secondary filter pack, 2 to 3 feet thick, above the primary filter pack (Nielsen and Schalla, 2006).

SEAL DESIGN

Annular seals should incorporate measures to prevent infiltration into the filter pack. Contact with the seal can cause sampled ground water to be artificially high in pH. Additionally, bentonite has a high cation exchange capacity, which may affect the chemistry of samples (Aller et al., 1991). In the saturated zone, a 2-foot pure bentonite seal can minimize the threat of infiltration. Above the bentonite seal, neat cement or bentonite grouts should be placed in the remainder of the annulus to within a few feet of the surface.

SEAL INSTALLATION

Bentonite

Annular seals should be installed using techniques that prevent bridging, which may cause gaps, cracking or shrinking. Surface water and/or contaminants potentially can migrate through any voids created. Bentonite that comes in contact with ground water may affect the chemistry of the ground water due to its high pH and high cation exchange capacity. Cations in the molecular structure of the bentonite may exchange with cations existing in the ground water. Because of this, bentonite sealing material should be placed a minimum of 3 to 5 feet above the top of the well screen. Use of a secondary filter pack above the primary filter is also recommended (Nielsen and Schalla, 2006). The bentonite seal above the filter pack is commonly installed by placing granular bentonite, bentonite pellets, or bentonite chips around the casing by dropping them directly down the annulus. If feasible, this practice is acceptable for wells less than 30 feet deep if a tamping device is used. However, for wells deeper than 30 feet, coarse-grained bentonite should be placed by means of a tremie pipe.

The bentonite should be allowed to hydrate or cure prior to sealing the remainder of the annular space. This will help prevent the grout from penetrating into the screened interval. Because bentonite chips or pellets requires a sufficient quantity and quality of water in order to achieve and retain hydration, bentonite chips or pellets generally should only be used in the saturated zone. If a two foot bentonite seal is desired in the unsaturated zone, granular bentonite should be used. It should be added and hydrated in lifts of 2 to 3 inches using water that is potable and free of analytes of concern (Nielsen and Schalla, 2006).

For the remainder of the annulus, sealants should be in slurry form (e.g., cement grout, bentonite slurry) and should be placed with a tremie pipe (Figure 7.4). The grout should be mixed using a paddle-type mechanical mixer or by circulating the grout through a pump to disintegrate the lumps (ASTM 50-92-04). The grout should be placed with a tremie pipe. The bottom of the pipe should be equipped with a side discharge deflector to prevent the slurry from jetting a hole through the filter pack. The seal should be allowed to completely hydrate, set, or cure in conformance with the manufacturer's specifications prior to completing the surface seal and developing the well.

Neat Cement

Neat cement should not be poured into the annulus unless there is at least 3 inches between the casing and borehole, the annulus is dry, and the grout is being placed within 30 feet of the surface. If the neat cement grout is poured through standing water the mixture may be diluted or bridging may occur (Nielsen and Schalla, 2006). A neat cement grout should be mixed as with bentonite grout. A tremie pipe should be used for placement and inserted in the annulus to within a few inches of the bottom of the space using a side discharge port.

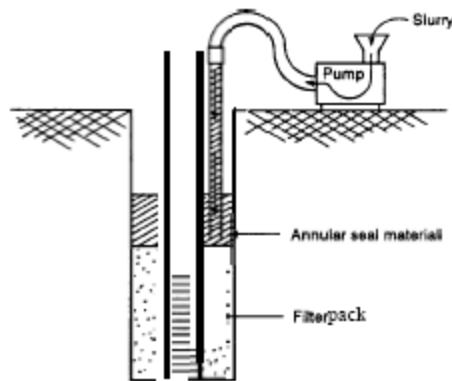

Figure 7.3 Tremie pipe emplacement of annular seal material (Source: Aller et al., 1991).

SURFACE SEAL/PROTECTIVE CASING COMPLETIONS

A surface seal is used to prevent surface runoff from entering the well annulus. The surface seal and protective casing also serve to provide protection from accidental damage or vandalism.

SURFACE SEAL

A neat cement or concrete surface seal should be placed around a protective casing to a depth just below the frost line (3-5 ft.). If the same material was used in the annular seal, the surface seal can be a continuation; otherwise, the surface seal is installed directly over the annular seal after settling and curing. The surface seal should slope away from the well and extend beyond the edge of the borehole to divert surface water. Air-entraining cements may be desirable in cold climates to alleviate cracking caused by freezing and thawing.

ABOVE-GROUND COMPLETIONS

Whenever possible, monitoring wells should extend above the ground surface to prevent surface water from entering and to enhance visibility. From the frost line upward, a steel protective casing should encompass the well. The protective casing should be at least two inches larger in diameter than the inner casing, extend above it, and have a locking cap. The lock should be protected by plastic or rubber covers so the use of lubricants to free and maintain locking mechanisms can be avoided. A small drain or "weep hole" should be located just above the surface seal to prevent the accumulation of water between the casings (See Figure 7.1). This is especially useful in cold climates, where the freezing of trapped water can damage the inner casing. In areas susceptible to flooding, the protective casing should extend high enough to be above flood level (Nielsen and Schalla, 2006). A permanent reference point on the well inner casing must be surveyed to the nearest 0.01 ft. This permanent marker should be used for all water level measurements. Additionally, the well identification number or code should be marked permanently and clearly.

Bumper or barrier guards should be placed beyond the edge of the surface seal or within 3 to 4 feet of the well (See Figure 7.1). These guards are necessary to reduce and prevent accidental damage from vehicles. Painting the guard posts yellow or orange and installing reflectors can increase visibility and help prevent mishaps.

FLUSH-TO-GROUND COMPLETIONS

Flush-to-ground completions are discouraged because the design increases the potential for surface water infiltration; however, they are occasionally unavoidable. This type of completion is generally used only when the location of a well would disrupt traffic areas such as streets, parking lots, and gas stations, or where easements require them (Nielsen and Schalla, 2006).

If flush-to-ground completion is installed, very careful procedures should be followed. A secure subsurface vault generally is completed in the surface seal, allowing the well casing to be cut below grade. The vault should be traffic-rated, and constructed of steel, aluminum, or a high-strength plastic composite material (Nielsen and Schalla, 2006). An expandable locking cap on the casing and a water-proof gasket should be installed around the vault lid to

prevent surface water infiltration. The gasket should be inspected at regular intervals and properly maintained to ensure a watertight seal (Nielsen and Schalla, 2006). The completion should be raised slightly above grade and sloped away to help divert surface water. It should be marked clearly and locked to restrict access. This is especially important at gas stations to prevent the misidentification of wells as underground tank filling points. In cold-weather areas where parking lots and roads may be cleared of snow with snowplows, the well vault should be set slightly below the surrounding concrete or asphalt to prevent shearing off of the vault lid by the blade of a snowplow. Flush-to-ground well completions should never be installed in low-lying areas that undergo flooding (Nielsen and Schalla, 2006).

DOCUMENTATION

During monitoring well installation, pertinent information should be documented, including design and construction, the drilling procedure, and the materials encountered (see Chapter 3 for a listing of the particular geologic information needs). Accurate "as-built" diagrams should be prepared that, in general, include the following:

- Date/time of start and completion of construction.
- Boring/well number.
- Drilling method and drilling fluid used.
- Borehole diameter and well casing diameter.
- Latitude and longitude.
- Well location (± 0.5 ft.) with sketch of location.
- Borehole depth (± 0.1 ft.).
- Well depth (± 0.1 ft.).
- Casing length and materials.
- Screened interval(s).
- Screen materials, length, design, and slot size.
- Casing and screen joint type.
- Depth/elevation of top and bottom of screen.
- Filter pack material/size, volume calculations, and placement method.
- Depth/elevation to top and bottom of filter pack.
- Annular seal composition, volume, and placement method.
- Surface seal composition, placement method, and volume.
- Surface seal and well apron design/construction.
- Depth/elevation of water.
- Well development procedure and ground water turbidity.
- Type/design of protective casing.
- Well cap and lock.
- Ground surface elevation (± 0.01 ft.).
- Surveyed reference point (± 0.01 ft.) on well casing.
- Detailed drawing of well (include dimensions).
- Point where water encountered.
- Water level after completion of well development.

In addition, the following should be documented in work plans (when appropriate) and reports:

- Selection and rationale materials for selection of casing and screen.
- Selection and rationale for well diameter, screen length, and screen slot size.
- Filter pack selection and emplacement.
- Annular sealant selection and emplacement.
- Security measures.
- Locations and elevations of wells.
- Well development.

A complete, ongoing history of each well should be maintained. This can include sample collection dates, dates and procedures for development, water level elevation data, problems, repairs, personnel, and methods of decommissioning. This information should be kept as a permanent on-site file, available for agency review upon request.

On July 18, 1990, Ohio House Bill 476 went into effect. This bill requires that all logs for monitoring wells drilled in Ohio be submitted to the Ohio Department of Natural Resources, Division of Water (ODNR). The ODNR can be contacted for further information.

MAINTENANCE AND REHABILITATION

The condition of wells must be maintained to keep them operational and insure that representative samples can be obtained. The maintenance program should be site-specific and take into account all information that could affect well physical and chemical performance (ASTM Method D 5978-96(2005)).

Maintenance consists of conducting inspections and periodic checks on performance. Proper documentation (see previous section) is needed to serve as a benchmark for evaluation, as well as to track well maintenance activities. Current conditions should be compared to as-built diagrams and previous measurements. Maintenance includes, but is not limited to, the following:

- Ensuring visibility and accessibility.
- Inspecting locks for rusting.
- Inspecting surface pad and seals for cracking.
- Checking survey marks to insure visibility.
- Determining depth (see Chapter 10 for recommended procedures).
- Removing sediments (if needed).
- Evaluating performance by doing hydraulic conductivity tests.
- Evaluating turbidity and re-developing or replacing well if turbidity increases.
- Evaluating well construction using geophysical logs or down hole cameras.

Routine inspections generally can be conducted during sampling. Additional evaluation can be conducted by comparing new ground water quality data and with previous data. If the maintenance check indicates a problem, rehabilitation should be conducted. Well rehabilitation activities include redevelopment to remove fine-grained materials or entrapped pollutants from the well. See Chapter 8: Monitoring Well Development for further information on well development.

REFERENCES

- Aller, L., T. W. Bennett, G. Hackett, R. J. Petty, J. H. Lehr, H. Sedoris, D. M. Nielsen, and J. E. Denne. 1991. Handbook of Suggested Practices for the Design and Installation of Ground-Water Monitoring Wells. Environmental Monitoring Systems Laboratory, Office of Research and Development, U.S. Environmental Protection Agency. Las Vegas, Nevada. EPA/600/4-89/034. (In cooperation with the National Water Well Association, Dublin, Ohio).
- American Society For Testing and Materials (ASTM), Method C150 07. Standard Specification for Portland Cement. Annual Book of American Society For Testing and Material Standards. Philadelphia, Pennsylvania Vol. 4.01, pp. 11-125.
- ASTM, Method D5092-90 -04e1. Standard Practice for Design and Installation of Ground Water Monitoring Wells in Aquifers. Annual Book of American Society for Testing and Material Standards. Philadelphia, Pennsylvania. Vol. 04.09, pp. 162-173.
- ASTM Method D 5978-96 (2005). Standard Guide for Maintenance and Rehabilitation of Ground-Water Monitoring Wells. American Society for Testing and Material Standards. West Conshohocken, Pennsylvania.
- ASTM D 6725-04, Standard Practice for Direct Push Installation of Prepacked Screen Monitoring Wells in Unconsolidated Aquifers. American Society for Testing and Material Standards. West Conshohocken, Pennsylvania.
- ASTM, Method F480-90. Standard Specifications for Thermoplastic Well Casing Pipe and Couplings Made in Standard Dimension Ratios (SDR) SCH40 and SCH80. Annual Book of American Society for Testing Material Standards. Philadelphia, Pennsylvania. Vol. 04.08, pp. 792-805.
- Barcelona, M. J., J. P. Gibb and R. Miller. 1983. A Guide to the Selection of Materials for Monitoring Well Construction and Ground Water Sampling. Illinois State Water Survey, SWS Contract Report 327. Champaign, Illinois.
- Barcelona, M. J. and J. A. Helfrich. 1988. Laboratory and Field Studies of Well Casing Material Effects. Proceedings of the Ground Water Geochemistry Conference. National Water Well Association. Dublin, Ohio. pp. 363-375.
- Campbell, M. D. and J. H. Lehr. 1973. Water Well Technology. McGraw-Hill Book Company. New York, New York.
- Calhoun, D. E., Sealing well casings: and idea whose time has come, 1988. Water Well Journal, Volume 42, Number 2, pp. 25-29.
- Christman, M., C.H. Benson, T.B. Edil. 2002. Geophysical Study of Annular Well Seals. Ground Water Monitoring and Remediation. Volume 22, Number 3, pp. 104-12.
- Curran, C. M. and M. B. Tomson. 1983. Leaching of Trace Organics into Water from Five Common Plastics. Ground Water Monitoring Review. Vol. 3, No. 3, pp. 68-71.

- Dablow, J.S. III, D. Persico and G.R Walker. 1988. Design Considerations and Installation Techniques for Monitoring Wells Cased with Teflon PTFE. In: A. J. Collins and A. I. Johnson (editors), Ground-Water Contamination Field Methods. ASTM STP 963. American Society for Testing Materials. Philadelphia, Pennsylvania. pp. 199-205.
- Driscoll, F.G. (editor). 1986. Ground Water and Wells. Second Edition. Johnson Division. St. Paul, Minnesota.
- Edil, T.B., M.M.K. Chang, L.T. Lan, T.V. Riewe. 1992. Sealing Characteristics of Selected Grouts for Water Wells. Ground Water. Volume 30, Number 3, pp. 351-361.
- Einarson, Murray D., and John A. Cherry. A New Multilevel Ground Water Monitoring System Using Multichannel Tubing, 2002. Ground Water Monitoring and Remediation, Volume 22, Number 4, pp. 52-65.
- Gaber, M. S. and B. O. Fisher. 1988. Michigan Water Well Grouting Manual. Division of Water Supply, Bureau of Environmental and Occupational Health, Michigan Department of Health. Lansing, Michigan.
- Gillham, R. W. and S. F. O'Hannesin. 1990. Sorption of Aromatic Hydrocarbons by Materials Used in the Construction of Groundwater Sampling Wells. Institute of Groundwater Research, University of Waterloo. Ontario, Canada.
- Hewitt, A.D. 1994. Dynamic Study of Common Well Screen Materials. Ground Water Monitoring and Remediation. Vol. 14, No. 1, pp. 87-94.
- Hewitt, A.D. 1992. Potential of Common Well Caseing Materials to Influence Aqueous Metal Concentrations. Ground Water Monitoring Review. Vol. 12, No. 2, pp. 131-136.
- Jones, J. N. and G. D. Miller. 1988. Adsorption of Selected Organic Contaminants Onto Possible Well Casing Materials. In: A. G. Collins and A. I. Johnson (editors), Ground-Water Contamination Field Methods. ASTM STP 963. American Society for Testing and Material Standards. Philadelphia, Pennsylvania. pp. 185-198.
- Lehr, J. H., S. Hurlburt, B. Gallagher and J. Voytek. 1988. Design and Construction of Water Wells. Van Nostrand Reinhold. New York, New York.
- Listi, R., Monitoring Well Grout: Why I think bentonite is better, 1993. Water Well Journal, May, 5-6, 1993.
- Michigan Department of Environmental Quality, 2007. Ground Water & Wells Fundamentals and Water Well Inspector's Manual. Lansing, Michigan.
- Miller, G. D. 1982. Uptake and Release of Lead, Chromium, and Trace Level Volatile Organics Exposed to Synthetic Well Casings. Proceedings of the Second National Symposium on Aquifer Restoration and Ground-Water Monitoring. National Water Well Association. Dublin, Ohio. pp. 236-245.

- NSF International. 2004. Plastic Piping Components and Related Materials, NSF Standard Number 14. Ann Arbor, Michigan.
- Nielsen, D. M. and R. Schalla. 2006. Design and Installation of Ground Water Monitoring Wells. In: David M. Nielsen (editor), Practical Handbook of Ground-Water Monitoring. Lewis Publishers, Inc. Chelsea, Michigan. pp. 639-806.
- NWWA/Plastic Pipe Institute. 1981. Manual on the Selection and Installation of Thermoplastic Water Well Casing. National Water Well Association. Worthington, Ohio.
- Parker, L. V. and T. F. Jenkins. 1986. Suitability of Polyvinyl Chloride Well Casings for Monitoring Munitions in Ground Water. Ground Water Monitoring Review. Vol. 6, No. 3, pp. 92-98.
- Parker, L. V., A. D. Hewitt, and T. F. Jenkins. 1990. Influence of Casing Materials on Trace-Level Chemicals in Well Water. Ground Water Monitoring Review. Vol. 10, No. 2, pp. 146-156.
- Parker, L.V. and T.A. Ranney, 1994. Effect of Concentration on Sorption of Dissolved Organics by PVC, PTFE, and Stainless Steel Well Casings. Ground Water Monitoring and Remediation. Vol. 14, No. 3, pp. 139-149.
- Reynolds, G. W. and R. W. Gillham. 1985. Absorption of Halogenated Organic Compounds by Polymer Materials Commonly Used in Ground Water Monitoring. Proceedings of the Second Canadian/American Conference on Hydrogeology. National Water Well Association. Dublin, Ohio. pp. 198-204.
- Rinaldo-Lee, M.B. 1983. Small vs. Large Diameter Monitoring Wells. Ground Water Monitoring Review. Vol.3, No. 1, pp. 72-75.
- Schalla, R. and P. L. Oberlander. 1983. Variation in the Diameter of Monitoring Wells. Water Well Journal. Vol. 37, No. 5, pp. 56-73.
- Schmidt, K. D. 1982. The Case for Large Diameter Monitoring Wells. Water Well Journal. Vol. 36, No. 12, pp. 28-29.
- Schmidt, G. W. 1987. The Use of PVC Casing and Screen in the Presence of Gasolines on the Ground Water Table. Ground Water Monitoring Review. Vol. 7, No. 2, p. 94.
- Sykes, A. L., R. A. McAllister and J. B. Homolya. 1986. Sorption of Organics by Monitoring Well Construction Materials. Ground Water Monitoring Review. Vol. 6, No. 4, pp. 44-48.
- Tomson, M. B., S. R. Hutchins, J. M. King and C. H. Ward. 1979. Trace Organic Contamination of Ground Water: Methods for Study and Preliminary Results. Third World Congress on Water Resources. Vol. 8. Mexico City, Mexico. pp. 3701-3709.
- U.S. EPA. 1975. Manual of Water Well Construction Practices. Office of Water Supply. EPA/ 570/9-75-001.

U.S. EPA. 1992. RCRA Ground-Water Monitoring: Draft Technical Guidance. Office of Solid Waste. EPA/530/R/93-001, Dockette #F/93/GWMA/FFFF. Washington, D.C.

Wisconsin Code. 1990. Ground Water Monitoring Requirements. Wisconsin Department of Natural Resources. Chapter NR 141.01 to NR 141.31. Wisconsin Register No. 409.

Division of Drinking and Ground Waters

Technical Guidance Manual for Ground Water Investigations

Chapter 8

Monitoring Well Development, Maintenance, and Redevelopment

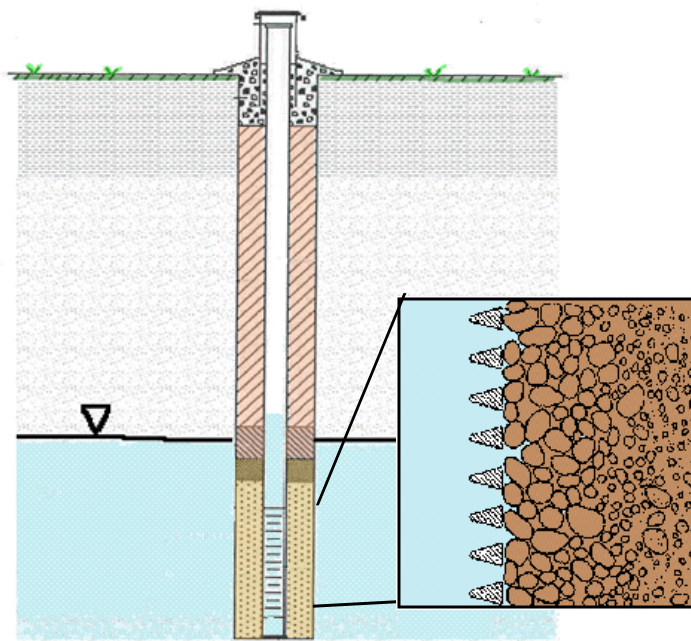

February 2009

Governor : Ted Strickland
Director : Chris Korleski



**TECHNICAL GUIDANCE
MANUAL FOR
GROUND WATER INVESTIGATIONS**

CHAPTER 8

**MONITORING WELL DEVELOPMENT,
MAINTENANCE, AND REDEVELOPMENT**

February 2009
Revision 2

Ohio Environmental Protection Agency
Division of Drinking and Ground Waters
P.O. Box 1049 50 W. Town Street, Suite 700
Columbus, Ohio 43216-1049
Phone: 614-644-2752
<http://www.epa.state.oh.us/ddagw/>

PREFACE

This document is part of a series of chapters incorporated in Ohio EPA's *Technical Guidance Manual for Hydrogeologic Investigations and Ground Water Monitoring* (TGM), which was originally published in 1995. DDAGW now maintains this technical guidance as a series of chapters rather than as an individual manual. The chapters can be obtained at <http://www.epa.state.oh.us/ddaqw/tgmweb.aspx>.

The TGM identifies technical considerations for performing hydrogeologic investigations and ground water monitoring at potential or known ground water pollution sources. The purpose is to enhance consistency within the Agency and inform the regulated community of the Agency's technical recommendations and the basis for them. In Ohio, the authority over pollution sources is shared among various Ohio EPA divisions, including the Emergency and Remedial Response (DERR), Hazardous Waste Management (DHWM), Solid and Infectious Waste (DSIWM), and Surface Water (DSW), as well as other state and local agencies. DDAGW provides technical support to these divisions.

Ohio EPA utilizes **guidance** to aid regulators and the regulated community in meeting laws, rules, regulations and policy. Guidance outlines recommended practices and explains their rationale. The Agency may not require an entity to follow methods recommended by this or any other guidance document. It may, however, require an entity to demonstrate that an alternate method produces data and information that meet the pertinent requirements. The procedures used to meet requirements usually should be tailored to the specific needs and circumstances of the individual site, project, and applicable regulatory program, and should not comprise a rigid step-by-step approach that is utilized in all situations.

MAJOR TECHNICAL CHANGES

Ohio EPA Technical Guidance Manual for Hydrogeologic Investigations and Ground Water Monitoring (TGM) was finalized in 1995 and Chapter 8 (Monitoring Well Development, Maintenance, and Redevelopment) was revised in February 2004. This guidance document represents the second revision to Chapter 8. Listed below are the major changes from February 2004.

1. Revised the water quality indicator parameter values used to evaluate whether the well has been properly developed.
2. Added a recommendation for a time interval between development and sampling of one week.

TABLE OF CONTENTS

PREFACE.....	i
MAJOR TECHNICAL CHANGES.....	ii
TABLE OF CONTENTS.....	iii
FACTORS AFFECTING DEVELOPMENT.....	1
HYDROGEOLOGIC ENVIRONMENT.....	1
WELL DESIGN.....	2
DRILLING METHODS.....	3
PRESENCE OF NON-AQUEOUS PHASE LIQUIDS.....	3
INTENDED USE.....	3
OTHER FACTORS.....	3
DEVELOPMENT PROCEDURE.....	4
PREDEVELOPMENT.....	4
DEVELOPMENT CRITERIA.....	4
METHODS.....	6
Pumping and Overpumping.....	6
Surging.....	7
Backwashing.....	9
Bailing.....	9
Air-lift Pumping and Air Surging.....	9
Inertial Lift Pump.....	10
WELL DEVELOPMENT DOCUMENTATION.....	11
TIME INTERVAL BETWEEN DEVELOPMENT AND SAMPLING.....	11
WELL MAINTENANCE CHECKS AND REDEVELOPMENT.....	13
REFERENCES.....	14

CHAPTER 8 MONITORING WELL DEVELOPMENT, MAINTENANCE, AND REDEVELOPMENT

The goal of ground water sampling is to obtain a sample that represents the current ground water conditions. Well development, well maintenance, and re-development (as needed) are critical to any ground water sampling program. The well development procedure and maintenance of the well should be documented.

Due to the effects of installation, the ground water entering a monitoring well may not be representative of natural conditions with respect to yield, chemical characteristics, and amount of suspended particulate matter. To allow for the collection of representative samples or physical properties (e.g., hydraulic conductivity), wells must be developed properly. Development involves stressing the formation so that a graded filter pack is created around the screen and particulate matter and fluids (when used) remaining from well drilling and construction are removed. Development restores hydraulic conditions and enhances yield of the saturated zone, stabilizes chemical changes that may have occurred during drilling and construction, and produces a well that is capable of yielding a sample of acceptably low turbidity (Panko and Barth, 1988; Aller et al., 1991, Izraeli et al., 1992).

Proper development creates a graded filter pack around the well screen. When pumping is first initiated, natural materials in a wide range of grain sizes are drawn into the well, producing very turbid water. As pumping continues, natural materials are drawn into the filter, producing an effective filter pack through a sorting process. This sorting process begins when the largest particles are retained by the filter pack, resulting in a layer of coarse particles against the screen. With continued pumping this process produces a progressively finer layer until an effective graded filter pack is produced (Izraeli, et al., 1992).

As indicated above, a key aspect of development is that it can reduce sample turbidity by removing fine particulate matter (clay and silt) from the filter pack and the geologic formation near the well intake, enhancing inflow to the well. Additionally, it can increase the life of wells by reducing or eliminating the potential for filling with fine particles or organic matter. Such "silting up" reduces yield and can result in anaerobic activity (NCASI, 1981). It is essential that filtration not be viewed as a substitute for proper development.

FACTORS AFFECTING DEVELOPMENT

Several factors may affect the performance and selection of a method or combination of methods for monitoring well development. These include, but may not be limited to, site hydrogeologic environment, well design, drilling method employed (Aller et al., 1991), and intended use of the well.

HYDROGEOLOGIC ENVIRONMENT

Ground water moves more easily through permeable, consolidated formations and "clean", coarse-grained sand and gravel; therefore, development may be accomplished quickly and easily. In contrast, flow through relatively impermeable silty or clayey material is slow or

limited; consequently, the process can be difficult. Well development should be applied with great care to wells installed in predominantly fine-grained formations (e.g., silts and clays). Rigorous development techniques may actually increase the turbidity of the ground water.

The ease of development is usually less predictable for unconsolidated formations than for rock. In general, more difficulty may be encountered when materials are unconsolidated. If a borehole is not stable, even distribution of the filter pack around the screen may not be achieved, hindering development (Aller et al., 1991). If materials are silt and clay, drilling may cause smearing along the borehole wall, which also causes problems. On the other hand, drilling causes minimal damage to homogeneous sand and gravel, and development is not affected (Hackett, 1987).

Different types of formations may be developed more effectively by using certain techniques. For example, a highly stratified, coarse-grained deposit is handled best by methods that concentrate energy on small parts of the formation. If the deposit is rather uniform, techniques that apply the same force over the entire length of the well screen can produce satisfactory results. Techniques that withdraw water quickly can reduce the hydraulic conductivity of formations containing a significant amount of silt and clay (Driscoll, 1986). Development of fine-grained materials generally should be accomplished by gentle action (Gass, 1989).

WELL DESIGN

Typical monitoring well design (e.g., small diameter, artificial filter pack, and limited screen open area) makes development difficult. Generally, wells should be designed to keep entrance velocities low enough to avoid degassing and/or alteration of water quality (Gass, 1986). The thickness of the pack has considerable effect on the procedure because it reduces the amount of energy imparted to the borehole wall. The pack should be as thin as possible if development is to be effective at removing fine particulates. Conversely, it should be thick enough to ensure adequate borehole support and good distribution of material around the screen. Generally, a minimum of two inches is sufficient.

Selection of the proper screen slot size and configuration is also essential for successful development. Slots are chosen to permit removal of fine material from the formation (see Chapter 7). Large slots may filter too much material and cause settlement and damage. Alternatively, it may not be possible to develop or sample properly if the slots are too small. According to Driscoll (1986), development works best when screens have both maximum open area and a slot configuration that permits the forces to be directed efficiently into the formation. In general, screens that are continuous slot, wire-wound facilitate easier development because they have the greatest open area (Gass, 1986).

Large diameter wells (i.e., four inches or larger) are much easier to develop due to equipment availability. However, the high cost of construction materials has resulted in the installation of smaller wells with machine-slotted screens (Gass, 1986). The equipment available for small diameter wells (e.g., direct push pre-packed wells) may be limited to small capacity bailers, inertial lift pumps, and small diameter bladder pumps.

DRILLING METHODS

The drilling process influences not only choice of development procedures, but also the intensity with which the procedures should be applied (Aller et al., 1991). All drilling methods impair the ability of a formation to transmit water to a borehole or well. Problems that can occur include: 1) the use of air rotary drilling to penetrate consolidated rock can cause fine particles to build up on the borehole walls and may plug fractures and pore spaces, 2) driving casing or using augers can cause smearing of fine-grained particulates between the casing/screen and the natural formation, 3) mud rotary can cause mudcakes to build up on the borehole wall, and 4) all drilling methods potentially can compact sediments. Development should rectify these problems to enhance yield and allow collection of representative samples.

Drilling fluid of any type can affect ground water quality; therefore, their use is discouraged. If a fluid is used, development should remove any that has infiltrated into the formation to allow in-situ ground water quality to return to pre-installation conditions.

PRESENCE OF NON-AQUEOUS PHASE LIQUIDS

Prior to development, the well should be checked for the presence of non-aqueous phase liquids (NAPL). If present, consideration should be given to the degree the well should be developed or even if the well should be developed. Care will need to be taken so that development does not spread the NAPL across the entire screened interval (through the entire sand pack and along the adjacent formation.)

INTENDED USE

The development technique may also depend on the intended use of a well. Wells intended for hydraulic testing (e.g., pump tests and slug tests) may need to be developed at higher rates to allow for the accurate determination of hydraulic conductivity and yield. Rates may need to be similar to the expected pumping rates anticipated during the aquifer tests. When the well will not be sampled for quality, other methods, such as jetting, may be acceptable (See Driscoll, 1986).

OTHER FACTORS

Site accessibility and **type and availability of equipment** should be considered during the selection of an appropriate method or combination of methods. The need for **proper disposal of contaminated discharge water** also can drive selection. **Time and cost** may dictate selection; however, methods that minimize time and cost often prove to be inadequate. Cost/benefit analysis generally favors proper and complete development. If it is inadequate, time and cost for drilling, well installation, ground water sampling, and sample analysis may be wasted on data that is not representative

Development should be applied cautiously to wells that are known or **suspected to contain contaminants**, particularly those that pose a hazard through inhalation or direct contact. Appropriate safety precautions should be taken to protect field personnel. Also, it should be

noted that contaminated water and sediments removed during development may need to be drummed and disposed of properly.

DEVELOPMENT PROCEDURE

The general approach to development involves dislodging and removing fine-grained material and drilling fluids out of the ground water zone and into the well, and then from the well itself. This section describes development procedures, including predevelopment (measures taken during installation and construction), time and duration of development, and development methods.

PREDEVELOPMENT

Whenever possible, steps should be taken during well installation and construction to remove drilling cuttings and fluids prior to placement of the screen, filter pack, and annular seal. This may include removing water from the borehole prior to installation of the well screen and surging and removal of water after the sand pack has been installed, prior to installing the annular seal.

Typically, the water in the borehole is highly turbid and viscous from the drill cuttings. Removing this fluid prior to installing the screen and sand pack may make subsequent development efforts easier. An additional advantage to this technique is that the potential for "bridging" the sand pack during installation may be reduced because the viscosity of the water due to sediments in the boring is greatly reduced.

After the screen and sand pack are in place the well may be surged gently prior to installing the bentonite seal and grout (note that the augers/casing should be at the top of the sand pack during this process to prevent overlying material from falling into the sand pack). Surging at this time is advantageous in that it will be more effective in removing fines from the well and formation and grading and stabilizing the sand pack when the weight of the overlying grout is not present. Additional sand may need to be added to compensate for settling of the sand pack and ensure that sufficient separation exists between the annular seal and well intake. If surging is performed only after the well is completely installed (i.e., the grout is in place), there is a greater chance that the sand pack could settle and create a void between the sand pack and annular seal. If the annular seal sinks into the void space, the well could become contaminated with grout and may need to be replaced.

Mechanically surging the well using the drill rig is likely to be more effective and is much easier than trying to do it manually after the well is installed. Care should be taken not to place too large a force on the well that may cause it to collapse.

DEVELOPMENT CRITERIA

Development should not be implemented until the seal has cured and settled. Ideally, a time of 48 hours is required for neat cement and bentonite grout mixtures (Gaber and Fisher, 1988). However, the time required varies with site conditions and grout type.

The duration of development varies with the type of formation, screen length, height of the water column, thickness of filter pack, and method used. The most frequent mistake is to “give up” before the well has been adequately developed. Adequate development may take less than two hours to more than three days.

Development should proceed until the following criteria are met:

1. Water can enter as readily as hydraulic conditions allow.
2. A representative sample can be collected. In general, representative conditions can be assumed when the water is visually clear of sediments (e.g., turbidity \leq 10 NTU) and pH, and specific conductance have stabilized over at least three successive well volumes. Other criteria such as temperature, oxidation-reduction potential or dissolved oxygen may also be useful to determine whether a well can produce a representative sample. Stability criteria of water quality parameters listed in Table 8.1 can be used to determine when development objectives have been met. The duration, along with pH, temperature, specific conductivity measurements, and turbidity should be recorded on the well development record (See section on Development Documentation).

In some instances, collection of a sample with a turbidity of \leq 10 NTU is difficult or unattainable. If a well does not provide a sediment-free sample, development can stop when all of the following conditions are met:

- Several procedures have been tried,
 - Proper well construction has been verified,
 - Turbidity has stabilized within \leq 10% over three successive well volumes, and
 - Conductivity, and pH have stabilized over at least three successive well volumes. (It should be noted that pH, temperature, and conductivity may not stabilize if water quality has been degraded).
3. The sediment thickness remaining in the well is less than 1 percent of the screen length or less than 0.1 feet for screens equal to or less than 10 feet.
 4. A minimum of three times the standing water volume in the well (to include the well screen, casing, plus saturated annulus, assuming 30 percent annular porosity) should be removed. In addition to the “three times standing water volume” criteria, further volumetric removal should be considered if fluids were utilized during well drilling and installation.

Table 8.1. Water-Quality Indicator Parameters (ASTM Standard D6771-02).

Parameter	Stabilization Criteria
pH	± Difference of ±0.2
specific electric conductance	□ Difference of ± 3%
temperature	□ Difference of ± 0.5 °C
turbidity	□ ±10% (when turbidity is greater than 10 NTUs)
oxidation -reduction potential (ORP)	± 20 millivolts
dissolved oxygen (DO)	□ 10% or ±0.2 mg/L, whichever is greater

METHODS

In general, methods to develop monitoring wells include pumping, overpumping, surging, bailing, and backwashing. The most effective approach(s) generally is a combination of one or more methods that allow for water movement in both directions through the screen. A technique that allows for reversing the flow helps to minimize bridging in the formation and filter pack.

Other methods exist, such as airlifting, air surging, jetting with water or air, or adding chemicals. Although various chemicals, including acids, surfactants, chelating agents, wetting agents, disinfectants, and dry ice have been employed for water supply wells, their use for monitoring wells is generally not appropriate. The addition of air, water, or chemicals may affect sample analysis in unpredictable ways. Air forced into a formation can reduce its permeability (Kraemer et al., 1991) and can cause volatilization of organics, if present. Water should be added only on rare occasions (i.e., when an insufficient amount exists to provide enough energy to develop the wells adequately). If water is added, it should be chemically analyzed for potential impact on in-situ ground water quality.

The following provides a general description of methods commonly used. The advantages and disadvantages of each are summarized and procedures are provided.

Pumping and Overpumping

A widely accepted technique is to pump a well using an intake that is raised and lowered (without excessive surging) throughout the length of the screened interval (Puls and Powell, 1992). Methods that rely totally on pumping may not sufficiently stabilize the formation or the filter pack material. Although visibly clear water may eventually be discharged, any subsequent activity that agitates the water column can cause considerable turbidity (ASTM Standard D5521-05). Utilizing pumps in which the pumping action creates gentle surging or pumps that can be fitted with a surge block may enhance development. Backwashing may also be combined with pumping to create a surging action.

The recommended approach is to begin pumping at the top of the screen with low pumping rates and incrementally work down the well screen. The process should then be repeated in reverse, from the bottom of the well to the top. When there is no improvement in turbidity, the well should be allowed to equilibrate and then the process should be repeated at higher pumping rates. Alternate pumping and equilibration cycles should continue until the water is free of sediments and no additional sediment accumulates in the bottom of the well.

According to Keely and Boateng (1987), however, some settlement and further loosening of fines can occur after the first attempt. Accordingly, a final series of cycles may need to be conducted 24 hours later.

Monitoring well development should begin at low rates (e.g., 100 ml/min) and end at rates at least ten times the sampling rate; however, in most cases, higher rates will be needed. In particular, higher rates may be needed when the well is being used in hydraulic tests to determine hydraulic characteristics of the formation. Overpumping at a rate that substantially exceeds water removal during purging and sampling increases influx of fine particles, thereby opening screen slots, pore spaces, and fractures. High rates may not be advisable when wells are in a pristine area and adjacent to a contaminant plume because of the potential to draw in contaminants. Other disadvantages of pumping and overpumping include bridging of particles against the screen and the need for proper disposal of contaminated water.

Development by pumping is most effective in coarse-grained, unconsolidated deposits and rock formations. However, it generally has limited application in highly conductive formations because it is difficult to pump monitoring wells at sufficient rates to create the high entrance velocities necessary for removal of fine particulates (Barcelona et al., 1985). The pumps utilized should be capable of pumping at low to high rates and be controlled by valving. Small diameter pumps that offer a wide range have recently been developed.

Monitoring wells can be developed by using either a centrifugal or submersible pump. A centrifugal pump may be effective for low-yielding wells; however, it can be utilized only if the depth to water is less than approximately 25 feet. The use of a submersible pump is not limited by water level, but is affected by well diameter, construction material of the impeller, and type and concentration of contaminants. According to Kraemer et al. (1991), the presence of fine-grained materials can clog or damage pumps with plastic impellers. The bladder of squeeze-type pumps also may be damaged by fines. It is recommended that a bailer be initially used to remove accumulated sediments. Prior to well development, the pumps should be decontaminated in a manner consistent with the procedures described in Chapter 6 for drilling and subsurface sampling equipment.

Surging

Surging involves pulling and pushing water into and out of a well intake by using a plunger or block. This process destroys bridging and can be effective for small diameter monitoring wells. A surge block is a device with a flexible gasket that is close in size to the well diameter (Figure 8.1). It is attached to a rod that is raised and lowered. Water is forced out of the intake on the downstroke, breaking up the bridged sediments and enabling water and sediments to flow back into the well on the upstroke. The surge block should fit with a minimum clearance of one-fourth inch (Barcelona et al., 1985). It should be of sufficient weight to overcome the inertia and drag of the cable reel and friction of the discs against the casing on the downstroke. Also, it should be of sufficient density to overcome the effects of buoyancy (Schalla and Landick, 1986).

Prior to surging, wells should be bailed or pumped to make sure that water will enter the well. If water does not enter the well, then surging should not be conducted. The negative pressure on the upstroke can cause the well to collapse.

For screen lengths of five feet or less, surging above the screen is effective for the entire screen length (Gass, 1986). For lengths greater than five feet, surging should be initiated above the screen and worked gradually downward at 2-3 feet intervals as water begins to easily move in and out of the well screen. To minimize damage, surging should start slowly and increase in force during the process. High differential pressures may cause collapse of the well screen or casing or may damage the filter pack (e.g., channels or voids may form near the screen if the pack sloughs away) (Keely and Boateng, 1987). A significant amount of fines can accumulate in the well during surging. These fines can be forced back into the formation and also make it impossible to remove the surge block. Therefore, it is necessary to withdraw the block at intervals and remove the sediment with a sand pump or bailer.

According to a study by Paul et al. (1988), surging of wells screened in fine-grained sediments should be avoided because it increases turbidity, does not improve hydraulic response significantly, and is unnecessarily costly. However, gentle surging action to agitate the sand pack may assist in improving the turbidity of low-yielding saturated zones.

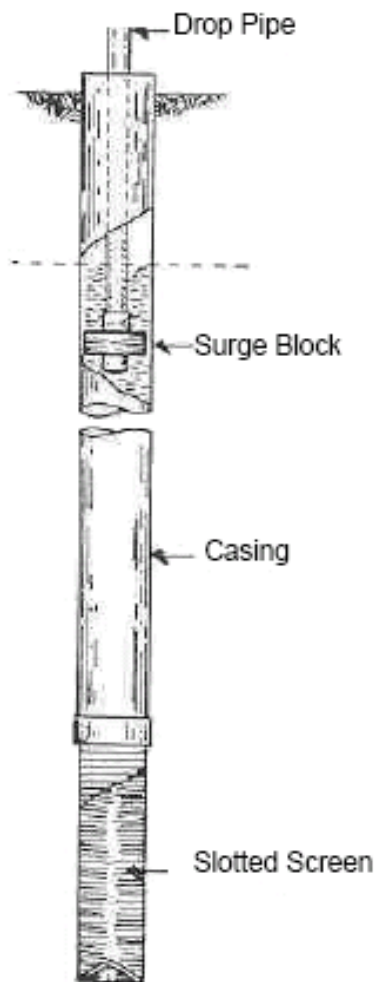

Figure 8.1 Development with a surge block (Source: "Monitoring Well Development" by T.E. Gass. *Water Well Journal*, Vol. 40, No. 1, p. 53 (Figure 1). 1986. Reprinted from *Water Well Journal* with permission from National Ground Water Association. Copyright 1986).

Backwashing

Backwashing or rawhiding (Gass, 1986) involves allowing water that is pumped to the top of a well to flow back through the pump and out through the well intake. Backwashing breaks up the bridged particles, allowing them to be pumped and removed; however, it may not be forceful enough to obtain favorable results. The method may only develop materials opposite the upper part of the intake or preferentially develop the most permeable zones in stratified deposits. Also, it may allow potentially contaminated water to enter uncontaminated zones. Thus, the technique may not be appropriate for areas of known or suspected contamination.

Bailing

In some instances, a bailer with a check valve at the bottom may be an effective method of development (Lapham, et. al., 1997). The bailer is rapidly lowered down the well until it hits the water column. The impact of the bailer on the water surface will initially force water into the formation. The withdrawal of the bailer causes water to flow back into the well. A stainless steel bailer is recommended to have sufficient weight to create the surging action. A bailer can also be fitted with a flange to serve as a surging tool.

To properly develop the well, rapid motions along the entire length of the intake should be done to create an inward and outward thrust of water that breaks up bridges that may have formed adjacent to the well intake. To enhance the removal of particulates accumulated at the bottom of the well, rapid short strokes near the bottom can be used to agitate and suspend sediments, thus allowing them to be removed. Development by bailing should be limited to gentle action in low-yielding wells (Gass, 1989). If a well is de-watered, it should be allowed to recover and bailing should be resumed.

Development by bailing is very labor-intensive. Depending on the volume of water that must be removed, it may be useful to rig a tripod and pulley to aid in the lifting of the bailer from the well (Kraemer et al., 1991). As with surging, care should be taken not to cause collapse of the well casing or screen.

Air-lift Pumping and Air Surging

Other techniques commonly utilized are air lift pumping and air surging. These methods may induce and trap air in the formation outside the well intake and alter ground water quality. Furthermore, if ground water is highly contaminated, the methods can expose field personnel to hazardous materials. Use is not recommended unless the technique does not introduce air into the well screen and it can be demonstrated that the quality of water to be sampled will not be affected. Air from the compressor should be filtered to insure that oil is not introduced into the well (Barcelona et al., 1985). Generally, air techniques may be effective at removing debris, but cause very little positive effect beyond the well screen (Gass, 1986).

One method that does not introduce air is **two pipe air-lift pumping** (Figure 8.2). Air is injected through the inner pipe at high pressure to bubble out into the surrounding outer pipe. The bubbles reduce the unit weight of the water, causing the column of water and sediments to be lifted upward, allowing ground water from the formation to flow into the well (Gass, 1986).

To avoid injecting air into the screened interval, Aller et al. (1991) recommended that the bottom of the pipe be no more than ten feet from the top of the screen. Scalf et al. (1981) indicated that the use of air is restricted by the submergence factor, which equals the height of water in feet above the bottom of the pipe while pumping (blowing water out) divided by the total length of the pipe. The submergence factor should be on the order of at least twenty percent. This may be difficult to achieve with many shallow wells.

Development by **air surging** involves applying air intermittently to allow water to fall back down the casing and create a backwashing or surging action to break up any bridging (Keely and Boateng, 1987). This method is not recommended because it causes mixing of aerated water with the water in the well (Aller et al., 1991). Schalla and Landick (1986) have developed an air-vented surge plunger for developing small-diameter wells that does not introduce air into the formation unless the unit is lowered into the screened interval.

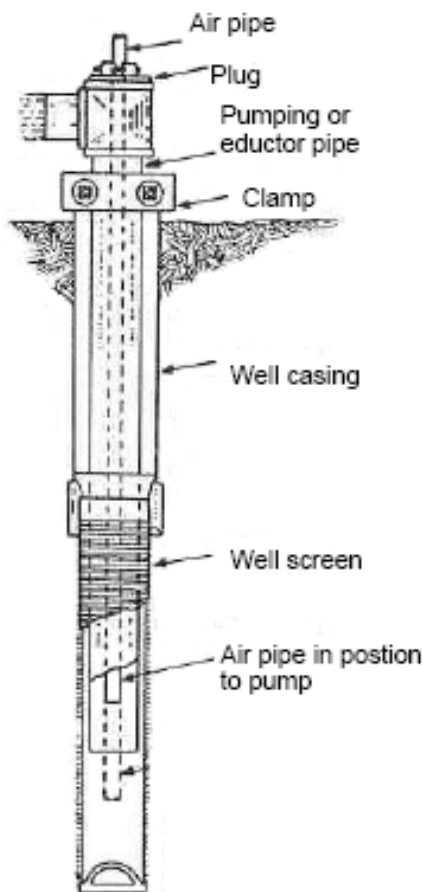

Figure 8.2: Two pipe air-lift system (Source: "Monitoring Well Development" by T.E. Gass. *Water Well Journal*, Vol. 40, No. 1, p. 54 (Figure 4). 1986. Reprinted from *Water Well Journal* with Permission from National Ground Water Association. Copyright 1986).

Inertial Lift Pump

Inertial lift pumps are constructed of a ball valve at the end of a flexible tube that runs to the surface. The sampler is lowered to the bottom of the well and the ball valve opens, allowing water to enter the tube. As well development begins the water column in the tubing is equal to that in the well. The tube is then lifted and dropped in a continuous up-and-down motion. As the tube is lifted, the water column is lifted in the tubing a distance equal to the stroke length. Lowering the tube allows the check valve to open, allowing water to enter the tubing.

The ball valve seats on the upstroke, capturing the water that has entered the tubing. This cycle continues with each up and down movement until water moves up and out of the tubing.

Inertial lift pumps are inexpensive, fairly portable, and easy to operate. They are particularly useful for development of small diameter wells (e.g., direct push pre-packed wells), since the tubing is available in sizes small enough to fit in small diameter wells. A potential drawback to inertial lift pumps is that in fine-grained formations over-surfing can cause the well screen to become clogged with fines; therefore, it may be necessary to perform additional purging with a non-surfing pump device to reduce turbidity (ASTM Standard D6724-04). Inertial lift pumps may be ineffective in removing large volumes of water and are not effective development tools for wells larger than 2 inches ID (ASTM Standard D6725-04).

Use of an inertial lift pump that is close in size to the inner diameter of the well can create a surging action in the well, while the pump simultaneously purges the well, removing the fines that are loosened by the surging action. Attachable surge blocks are available for some inertial lift pumps; however, this can increase the risk of clogging.

WELL DEVELOPMENT DOCUMENTATION

Well development documentation is important to show that representative samples can be obtained. Development method(s), time spent on development, volume of water removed, depth of the well, depth to top of the screen, diameter of the well, visual appearance (clarity), turbidity, pH, and specific electrical conductance of discharge water at various intervals should be recorded on a form or log (Lapham, et. al., 1997). Figure 8.3 provides an example of a well development record.

Information on recovery rates and estimated yield should also be documented. This information may be helpful in planning for sampling events and in sampling techniques.

TIME INTERVAL BETWEEN DEVELOPMENT AND SAMPLING

Prior to sampling a well, sufficient time should be allowed for equilibration with the formation after development. The intent is to provide time for the newly installed well and backfill materials to equilibrate to their new environment and for that environment to stabilize after disturbance. Though a significant volume of water may be pulled through the well during development, the well and granular backfill surfaces over which this water passes are not likely to be at chemical equilibrium with the ground water zone. The time for a well to stabilize depends on the characteristics of the ground water zone and the method of development; however, there is no rigorous scientific analysis to substantiate a time frame. A recommended "rule-of-thumb" is one week. Several weeks may be needed for lower permeability formations ($< 1 \times 10^{-6}$ cm/sec) (Israeli, et al, 1992; Byrnes et al., 1994; USACE, 1998). See section on "Development Criteria" for additional information on when a well can be considered properly developed.

Figure 8.3 EXAMPLE RECORD OF WELL DEVELOPMENT

Site Name:				Initial Well Depth:				Final Well Depth:			
Well ID:				Well Diameter:				Screen Length:			
Developers:				Static Water Level:				Total Purged Volume:			
Start Date:				End Date:				Weather Conditions:			
General Comments (e.g., presence of NAPLS):				General Development Method(s):							
Date	Time	Method	Pumping Rate (gal/min)	Volume Purged (gal)	Temp. (°C)	Spec. Cond. (µS/cm)	pH	Turbidity (NTU)	Other	Comments (e.g., clarity of water and success of development)	
Field Parameter and Stability Guidance: pH (□±0.2 standard units); Temperature (±0.5 °C); specific conductance (□±3%, µS/cm); turbidity (±10% when turbidity is greater than □ 10 NTU); dissolved oxygen (□ 10% or ±0.2 mg/L, whichever is greater); oxidation-reduction potential (□ ±20 ml/g)											
NTU- nephelometric unit, µS/cm- microsiemens per centimeter											

WELL MAINTENANCE CHECKS AND REDEVELOPMENT

During the course of their active lives, monitoring wells should be checked to confirm that the well is still intact and fine particles have not accumulated. Unlike water supply wells, monitoring wells remain predominantly unpumped. There is no continuous removal of fines over an extended period. According to Kraemer et al. (1991), no matter how complete development appears to be, there is a high probability (especially for wells completed in fine-grained formations) that introduction of pumps or bailers will create a surge rendering the water somewhat turbid. In addition to sediments accumulating in the well, the casing and screen can become corroded or plugged by chemical or bio-chemical precipitates, and thus cause a loss of hydraulic connection. Metal well casings are subject to degradation over time from exposure to corrosive ground waters (pH of less than 6.0). Polyvinyl chloride (PVC) casing can dissolve in the presence of PVC solvent or if a pure organic product reaches the well in high concentrations from chemical spills or leaking storage tanks. A deteriorating well structure or a well that is "silting up" can cause a bias to the data that might be difficult to detect or might even be interpreted as trends in ground water quality. To provide a representative sample, these wells should be restored. Restoration typically involves redevelopment.

It is recommended that performance be evaluated during the life of a well. This may include, but not be limited to, noting a significant drop in yield during purging, noting increased turbidity, measuring total well depth to determine if sediments have been deposited, and using a camera to determine if incrustation of the screen or damage to the well casing has occurred. Comparison of water-level fluctuations over time in the well can indicate a possible change in hydraulic connection of the well to the aquifer. For example, a long-term decline in the water level in a well could indicate gradual plugging of the well screen. Slug tests or injection, pressure, or partial-vacuum tests can also be conducted as part of the continual evaluation of the well (Stallman, 1983; Lohman, 1972; Driscoll, 1986; Bedinger and Reed, 1988). These tests help evaluate whether there is still good hydraulic connection between the well screen and the ground water zone.

Well maintenance records should be kept including, but not limited to, periodic checks on depths; trends in water levels, yield changes and turbidity; the external physical condition of the well, its protective casing, the surface seal; and other criteria utilized to monitor the integrity of the well. At minimum, wells should be redeveloped when 20% of the well screen is occluded by sediments (U.S. EPA, 1988), or records indicate a change in yield and turbidity.

REFERENCES

- Aller, L., T. W. Bennett, G. Hackett, R. J. Petty, J. H. Lehr, H. Sedoris, D.M. Nielsen, and J. E. Denne. 1991. Handbook of Suggested Practices for the Design and Installation of Ground Water Monitoring Wells. Environmental Monitoring Systems Laboratory, Office of Research and Development, U.S. Environmental Protection Agency. Las Vegas, Nevada. EPA/600/4-89/034. (In cooperation with the National Water Well Association, Dublin, Ohio).
- American Society for Testing Materials (ASTM), Designation D 5092-90. 1994. Standard Practice for Design and Installation of Ground Water Monitoring Wells in Aquifers. American Society for Testing Materials. West Conshohocken, Pennsylvania.
- ASTM Standard D5521-05. Standard Guide for Development of Ground-Water Monitoring Wells in Granular Aquifers. American Society for Testing Materials. West Conshohocken, Pennsylvania.
- ASTM Standard D 6724-04. Standard Guide for Installation of Direct Push Ground Water Monitoring Wells. American Society for Testing Materials. West Conshohocken, Pennsylvania.
- ASTM Standard D6725-04, Standard Practice for Direct Push Installation of Prepacked Screen Monitoring Wells In Unconsolidated Aquifers, West. Conshohocken, Pennsylvania.
- ASTM Standard D6723-01. Standard Practice for Direct Push Installation of Prepacked Screen Monitoring Wells in Unconsolidated Aquifers. American Society for Testing Materials. West Conshohocken, Pennsylvania .
- ASTM Standard D6771-02. Standard Practice for Low-Flow Purging and Sampling for Wells Devices Used for Ground-Water Quality Investigations. American Society for Testing Materials. West Conshohocken, Pennsylvania.
- Bedinger, M.S. and J.E. Reed. 1988. Practical Guide to Aquifer Tests Analysis. Environmental Monitoring Systems Laboratory. Office of Research and Development. United States Environmental Protection Agency. Las Nevada.
- Barcelona, M. J., J. P. Gibb, J. A. Helfrich, and E. E. Garske. 1985. Practical Guide for Ground-Water Sampling. Illinois State Water Survey, ISWS Contract Report 374. Champaign, Illinois.
- Byrnes, M.E., Leydorf, M.D., and Smet, D.B. 1994. Field Sampling Methods and Remedial Investigations. Lewis Publishers, Boca Raton, Florida.
- Driscoll, F. G. (editor). 1986. Groundwater and Wells. Second Edition. Johnson Division. St. Paul, Minnesota.

- Gaber, M. S. and B. O. Fisher. 1988. Michigan Water Well Grouting Manual. Division of Water Supply, Bureau of Environmental and Occupational Health, Michigan Department of Health. Lansing, Michigan.
- Gass, T. E. 1986. Monitoring Well Development. *Water Well Journal*. Vol. 40, No. 1, pp. 52-55.
- Gass, T. E. 1989. Monitoring Wells in Non-Aquifer Formations. *Water Well Journal*. Vol. 43, No. 2, pp.27-28.
- Hackett, G. 1987. Drilling and Constructing Monitoring Wells with Hollow-Stem Augers. Part 1: Drilling Considerations. *Ground Water Monitoring Review*. Vol. 7, No. 4, pp. 51-62.
- Izraeli, R., D. Yeskis, M. Collins, K. Davies, B. Zavala. 1992. Monitoring Well Development Guidelines for Superfund Project Managers. *Ground Water Forum*. United States Environmental Protection Agency. Office of Solid Waste and Emergency Response.
- Keely, J. F., and K. Boateng. 1987. Monitoring Well Installation, Purging, and Sampling Techniques-Part 1: Conceptualizations. *Ground Water*. Vol. 25, No. 3, pp. 300-313.
- Kraemer, C. A., J. A. Shultz and J. W. Ashley. 1991. Monitoring Well Post-Installation Considerations. In: D. M. Nielsen (editor), *Practical Handbook of Ground-Water Monitoring*. Lewis Publishers, Inc. Chelsea, Michigan. pp. 334-342.
- Lapham, W.W., F.D. Wilde, M.T. Koterba. 1997. Guidelines and Standard Procedures for Studies of Ground-Water Quality. Selection and Installation of Wells and Supporting Documentation. U.S. Geological Survey, Water Resource Investigation Report 96-4233. 110p.
- Lohman, S. W. 1972. *Groundwater Hydraulics*. U.S. Geological Survey Professional Paper 708. United States Government Printing Office. Washington, D.C.
- National Council of the Paper Industry for Air and Stream Improvement (NCASI). 1981. Ground Water Quality Monitoring Well Construction and Placement. Technical Bulletin 342. New York, New York. pp. 26-29.
- Paul, D.G., C.D. Palmer and D.S. Cherkauer. 1988. The Effect of Construction, Installation, and Development on the Turbidity of Water in Monitoring Wells in Fine-Grained Glacial Till. *Ground Water Monitoring Review*. Vol. 8, No. 1, pp. 73-82.
- Panko, A. W. and P. Barth. 1988. Chemical Stability Prior to Ground-Water Sampling: A Review of Current Well Purging Methods. In: A. J Collins and A. I. Johnson (editors), *Ground-Water Contamination Field Methods*. ASTM Publications. Baltimore, Maryland. pp. 232-239.
- Puls, R. W. and R. M. Powell. 1992. Acquisition of Representative Ground Water Quality Samples for Metals. *Ground Water Monitoring Review*. Vol. 12, No. 3, pp. 167-176.

- Scalf, M. R., J. F. McNabb, W. J. Dunlap, R. Crosby and J. Fryberger. 1981. Manual of Ground Water Sampling Procedures. National Water Well Association. Worthington, Ohio. (Part of a NWWA/US.EPA
- Schalla, R. and R. W. Landick. 1986. A New Valved and Air-Vented Surge Plunger for Developing Small- Diameter Monitoring Wells. Ground Water Monitoring Review. Vol. 6, No. 2, pp. 77-80.
- Stallman, R. W. 1983. Aquifer-Test Design, Observation and Data Analysis: U.S. Geological Survey Techniques of Water-Resource Investigations, Book 3, Chapter B1. United States Government Printing Office. Washington, D. C.
- USACE, 1998. Monitoring Well Design, Installation, and Documentation at Hazardous, Toxic, and Radioactive Waste Sites. Department of the Army. U.S. Army Corps of Engineers. EM 1110-1-4000. Washington, D.C.
- U.S. EPA. 1988. Operation and Maintenance Inspection Guide. Office of Waste Program Enforcement.



Technical Guidance Manual for Hydrogeologic Investigations and Ground Water Monitoring

Chapter 9

Sealing Boreholes and Decommissioned Monitoring Wells

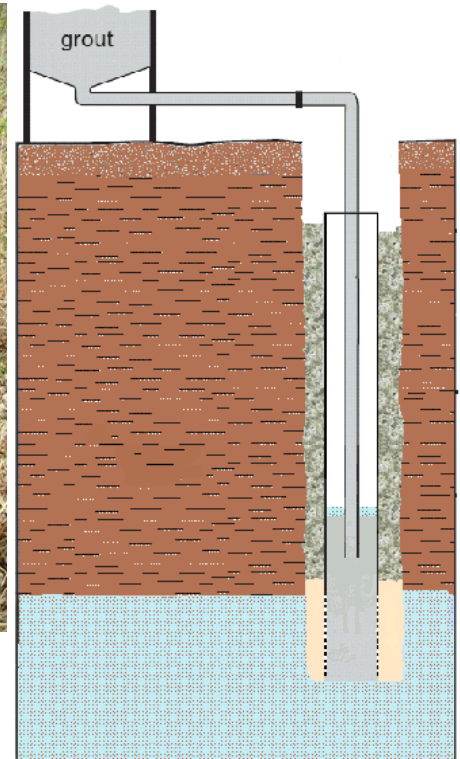

John R. Kasich, Governor
Mary Taylor, Lt. Governor
Craig W. Butler, Director

**TECHNICAL GUIDANCE MANUAL FOR HYDROGEOLOGIC
INVESTIGATIONS AND GROUND WATER MONITORING**

CHAPTER 9

**Sealing Boreholes and Decommissioned
Monitoring Wells**

September 2016

Revision 3

Ohio Environmental Protection Agency
Division of Drinking and Ground Waters
P.O. Box 1049
50 W. Town Street, Suite 700
Columbus, Ohio 43216-1049
Phone: 614-644-2752
epa.ohio.gov/ddaqw/

TABLE OF CONTENTS

TABLE OF CONTENTS	ii
PREFACE.....	iii
CHANGES FROM THE APRIL 2015 TGM	iv
1.0 SEALING MATERIALS	1
1.1 QUALIFICATIONS FOR SEALING MATERIALS.....	1
1.2 TYPES OF SEALING MATERIALS.....	2
1.2.1 Neat Cement or Sodium Bentonite	2
1.3 BENTONITE-CEMENT MIXTURE	2
1.4 USE OF CUTTINGS/OTHER MATERIALS.....	2
2.0 PROCEDURES	3
2.1 PLANNING	3
2.1.1 Historical and Current Conditions Review.....	3
2.1.2 Detailed Workplan.....	3
2.2 FIELD PROCEDURE.....	4
2.2.1 Inspection and Preparation.....	5
2.2.2 Casing Removal.....	5
2.2.3 Sealing in Place.....	5
2.2.4 Disinfecting Wells/Boreholes	6
2.2.5 Grouting the Borehole	7
2.2.6 Completion of Borehole	7
2.2.7 Final Surface Seal.....	7
2.3 DOCUMENTATION.....	8
2.3.1 Report Submittal to Ohio EPA.....	8
2.3.2 Report Submittal to Ohio Department of Natural Resources (ODNR).....	8
3.0 REFERENCES.....	10

PREFACE

The subject of this document is techniques to characterize hydrogeology beneath a site. It is part of a series of chapters incorporated in Ohio EPA's *Technical Guidance Manual for Hydrogeologic Investigations and Ground Water Monitoring* (TGM), which was originally published in 1995. Ohio EPA now maintains this guidance as a series of chapters rather than as an individual manual. These chapters can be obtained at epa.ohio.gov/ddagw/tgmweb.aspx.

The TGM identifies technical considerations for performing hydrogeologic investigations and ground water monitoring at potential or known ground water pollution sources. The purpose of the guidance is to enhance consistency within the Agency and inform the regulated community of the Agency's technical recommendations and the basis for them.

Ohio EPA utilizes guidance to aid regulators and the regulated community in meeting laws, rules, regulations and policy. Guidance outlines recommended practices and explains their rationale. The methods and practices described in this guidance are not intended to be the only methods and practices available to an entity for complying with a specific rule. Unless following the guidance is specifically required within a rule, the agency cannot require an entity to follow methods recommended by the guidance. The procedures used to meet requirements usually should be tailored to the specific needs and circumstances of the individual site, project, and applicable regulatory program, and should not comprise a rigid step-by-step approach that is utilized in all situations.

CHANGES FROM THE APRIL 2015 TGM

Ohio EPA's *Technical Guidance Manual for Hydrogeologic Investigations and Ground Water Monitoring* (TGM) was first finalized in 1995. Chapter 9 (Monitoring Well and Borehole Abandonment) was subsequently updated in February of 2009.

One major change has been made since February, 2009. Per the Ohio EPA DERR-SIFU FSOP 1.9, Boring and Monitoring Well Decommissioning, finalized in September, 2015, drill cuttings may be used to fill in the borehole under very specific circumstances (Section 1.4).

This is the third revision to the chapter.

Section numbers were added to make the document easier to read. Wording has been changed from "abandoning" to "decommissioning".

References were updated, in particular, the references to Ohio Water Resources Council's (OWRC) *Regulations and Technical Guidance for Sealing Unused Water Wells and Boreholes*, finalized March 2015.

CHAPTER 9

SEALING BOREHOLES AND DECOMMISSIONED MONITORING WELLS

Exploratory boreholes that are not completed as monitoring wells and decommissioned monitoring wells that no longer are needed for sampling or potentiometric monitoring should be sealed properly. Proper sealing is necessary to:

- prevent poor quality water from one saturated zone entering another;
- prevent contamination of the ground water by surface contaminants;
- restore an aquifer to as close to its original condition as possible;
- eliminate physical hazards; and
- reduce potential for future liability.

A suitable program should be designed and implemented to meet these objectives. This guidance document provides recommendations on sealing materials, procedures to appropriately seal a borehole or decommissioned monitoring well and documentation of sealing activities. The sealing material and method depends on:

- the design and construction of the well/borehole,
- hydrogeologic conditions,
- the chemical environment,
- safety hazards and
- disposal of contaminated materials removed.

In general, sealing should consist either of a method for well removal and simultaneous grouting of the borehole with sodium bentonite, neat cement, a bentonite/cement mixture, or a method for grouting in-place that ensures complete sealing. Additional guidance on sealing of all types of wells can be found in the [Regulations and Technical Guidance for Sealing Unused Water Wells and Boreholes](#) (OWRC, 2015).

1.0 SEALING MATERIALS

1.1 QUALIFICATIONS FOR SEALING MATERIALS

The chosen sealing material should:

- Not react with contaminants, ground water, or geologic materials;
- Have a hydraulic conductivity equivalent to or lower than the in-situ material;
- Form a tight bond with the borehole wall and well casing;
- Be resistant to cracking and/or shrinking;

- Be of sufficient structural strength to withstand subsurface pressures; and
- Be capable of being placed at the appropriate depth.

Chapter 7 (Monitoring Well Design and Installation) should be consulted for details on different types of sealants and their application. No single material exhibits all of the desirable characteristics. Therefore, every situation should be evaluated carefully to determine the appropriate choice. Generally, materials used are sodium bentonite, neat cement or a bentonite/cement mixture. Concrete, asphalt or soil may be used to complete the sealed boring or well near within two to three feet of the ground surface depending of site conditions.

1.2 TYPES OF SEALING MATERIALS

1.2.1 Neat Cement or Sodium Bentonite

Most wells completed in unconsolidated formations or non-creviced rock may be satisfactorily sealed with neat cement or sodium bentonite. "Neat cement" is comprised of Portland cement and fresh water with no aggregate added. Wells that penetrate limestone or other creviced or channeled rock formations should be filled with concrete grout or neat cement to ensure seal permanence. The use of fine-grained materials to seal creviced rock may not be desirable because the materials might be displaced by flow of water through crevices (American Water Works Association, 1984). Neat cement or sodium bentonite should be used for sealing a borehole or decommissioned monitoring well below the water table (Gordon and Koch, 1988). Above the water table, sodium bentonite should be utilized. Sodium bentonite chips or pellets placed above the water table require addition of water during sealing. Neat cement may shrink if placed above the water table.

1.3 BENTONITE-CEMENT MIXTURE

A common sealing practice is to use a bentonite-cement mixture. Some have recommended a two to six weight percent of bentonite mixed with neat cement to reduce shrinkage. However, this may actually increase shrinking as it ties up water that would be incorporated in the cement. In addition, bentonite cannot compensate for shrinkage, as much of the sodium associated with bentonite mixed into a cement slurry is replaced by calcium due to ion exchange. Calcium bentonite has little or no expansive capacity (Smith, 1994). Therefore, cement-bentonite sealants should be used with care (Christman et al., 2002; Edil et al., 1992).

1.4 USE OF CUTTINGS/OTHER MATERIALS

In general, use of cuttings is not recommended. However, soil borings that are 6 feet deep or less and do not intersect the water table may be backfilled with the soil cuttings, topsoil, or other clean fill materials (e.g., sand or gravel) rather than bentonite provided that:

- The Ohio EPA client division representative approves of using a clean soil or fill material;

- The soil boring does not encounter any hazardous waste, solid waste, or construction and demolition debris (C&DD) materials
- The soil cuttings or other materials used for backfill are not known to contain contaminants exceeding any federal or state regulatory concentration levels
- The soil cuttings or other materials used for backfill do not contain any solid waste or C&DD (DERR-SIFU's FSOP for Boring and Monitoring Well Decommissioning, 2015)

In coarse gravel, where excessive loss of sealing materials may occur, or when grout may affect the water quality of nearby monitoring wells, clean sand or gravel or crushed rock in conjunction with regular materials can be used (Gordon and Koch, 1988; Kraemer et al., 1991).

2.0 PROCEDURES

Ohio EPA recommends the following procedure for sealing exploratory boreholes and decommissioned monitoring wells. The first two steps (2.1.1 and 2.1.2) are not necessary for sealing of exploratory boreholes. Ohio EPA understands that no single sealing method and material are suitable for all situations. Site-specific characteristics may merit modifications of the procedures discussed below or alternative procedures. All procedures and materials used must effectively seal the borehole or monitoring well and be protective of human health and the environment. Additional information is available in the reference section.

2.1 PLANNING

2.1.1 Historical and Current Conditions Review

Careful review should be conducted prior to sealing monitoring wells. This may include:

- Review of records pertaining to well construction and repair or modifications;
- Review of analytical chemical data for soil and ground water;
- Review of the hydrogeologic/geologic characteristics in the vicinity of the well; and
- Current conditions of the well, such as, total depth, amount of siltation, etc.

If a well is to be left in place, borehole geophysical techniques may be helpful in determining its integrity. This may include caliper logs to measure inside diameter; television logs to identify casing breaks, screen size, etc.; gamma logs to verify geologic information; cement bond logs to determine if the casing is firmly attached to the grout; flow logs to determine if vertical flow occurs within the casing; and hydraulic integrity tests to determine if the casing is intact (ASTM, D5299-99(2012)e1). For additional information on downhole logs, see Chapter 16, Application of Geophysical Methods for Site Characterization.

2.1.2 Detailed Workplan

Prior to the sealing of monitoring wells, Ohio EPA recommends that a work plan detailing the procedures/methods be submitted to the appropriate regulatory authority. The work plan should include:

- 1. The reasons for decommissioning and sealing the monitoring well**
- 2. Monitoring well information:**
 - a. Identification/designation and location coordinates (latitude/longitude or state plane)
 - b. The following well construction information, preferably on a well construction diagram with a drilling log documenting hydrogeologic conditions:
 - i. Surface seal and surface casing types
 - ii. Borehole diameter
 - iii. Total depth
 - iv. Casing type, diameter and length
 - v. Grout type(s) and depth
 - vi. Screen type, diameter and length
 - vii. Filter pack type and depth
 - viii. Geologic characteristics of the saturated zone or aquifer
 - c. Type and concentrations of remaining contaminants (if any)
- 3. Sealing procedures** (for each monitoring well to be sealed)
 - a. Final static water level and total depth measurements
 - b. Method(s) used to seal the monitoring well
 - c. Type(s) of materials used to seal the monitoring well, including an estimated volume of the sealing materials used
 - d. Field notes/report documenting the sealing procedures, including documentation of any problems encountered and steps taken to resolve them
- 4. Measures to protect health and safety during sealing** (or a separate health and safety plan that includes monitoring well sealing)

2.2 FIELD PROCEDURE

Monitoring wells have often been sealed by pulling the surface casing where possible, followed by pouring cement or bentonite into the hole. This procedure is inappropriate, especially if the construction of the well is unknown or the well intake spans more than one saturated zone. Incomplete seals may form due to bridging. Additionally, the procedure has little effect on the filter pack, which may allow communication between saturated zones.

2.2.1 Inspection and Preparation

Inspect the well and remove any obstacles (i.e., pumps, pressure lines, other debris, etc.) that may interfere with the placement and performance of the sealing material. If necessary, a camera survey can help to identify the depth and construction of the well if this information is not known. The outer protective casing should be removed.

2.2.2 Casing Removal

When the annular seal is inadequate, the filter pack connects two or more water bearing zones, water is flowing from around the outside of the casing, or when construction details are not known, the casing, screen, annular seal and filter pack should be removed. The casing and well screen can be removed by pulling or bumping the casing, overdrilling around the casing using a hollow stem auger, or drilling out the well using a solid stem auger or rotary bit (see Table 9.1). The method used should depend on the type, length, and diameter of the casing, conditions of the annular seal, and site geology. Aller et al. (1991) and ASTM D5299-99(2012)e1 provide a discussion on various removal techniques. Ohio EPA recommends the borehole be overdrilled using a bit with a diameter at least 1.25 times greater than the original diameter of the borehole. Drilling should be slightly deeper than the original depth to assure complete removal. To achieve an effective seal, the borehole should be cleared of any excess mud filtercake.

Table 9.1 Techniques for casing removal.

TECHNIQUE	METHOD
Pulling or bumping	Use a rig to pull out the well casing. This may be appropriate only for steel casing since plastic/Teflon casing may break.
Overdrilling	Drill around the well using the well casing as a guide, then pull out the casing. This method is limited by well diameter due to the high torque required to turn large diameter augers.
Drilling through well	Use a solid stem or rotary bit to drill the casing out. This can be done only with plastic/Teflon well material. It can be difficult to retrieve the cutting.

2.2.3 Sealing in Place

In some instances, such as when safety problems occur or when dealing with large diameter wells, casing removal can be difficult. If circumstances prevent complete removal of casing and screen, then the following procedure can be used (based on Renz, 1989):

- The well can be filled with clean (ANS/NSF 61¹) filter sand to one foot above the screen in the event that the screened area is adjacent to a highly permeable formation.
- One foot of bentonite chips/pellets can be placed above the screen in a manner that prevents bridging (i.e., through a tremie pipe or by tamping after installation). (Note: chips are recommended below the water table because they quickly sink; processed pellets are lighter and tend to float and fall slowly through the water column.)
- The chips/pellets should be hydrated, if placed above the water table.
- To allow the sealant to permeate and be effective, the casing should be perforated to one foot above the bentonite seal either by splitting it vertically (synthetic casing) or by making horizontal cuts every two feet with a retractable blade (steel casing).

Since the primary purpose of sealing is to eliminate vertical fluid movement, it is recommended that the casing and screen be removed and the boring be overdrilled to remove the annular seal and filter pack. However, monitoring wells can be sealed in-place when the construction details are known, the annular seal is intact, and the filter pack does not cross more than one ground water zone.

2.2.4 Disinfecting Wells/Boreholes

Where evidence of microbiological growth is a concern, a monitoring well may need to be disinfected. However, before disinfecting, an evaluation as to whether this would affect water quality monitoring results in the proximity should be made.

When such a concern is present, wells should be disinfected by slowly wetting the circumference of the well/borehole with the disinfection solution by using a tremie pipe starting from the bottom of the well and working upwards to assure that all sides are wetted by the solution. The solution should be well mixed within the well/borehole and purged before sealing with grout. Contact of disinfectant with bentonite should be avoided. The bentonite grout will not seal properly if it comes into contact with the disinfection solution. The disinfectant should:

- Have a concentration in the water column of approximately fifty milligrams per liter (mg/L) total chlorine, but no more than 100 mg/L.
- Have standard ANSI/NSF 60 certification. Standard ANSI/NSF 60 refers to "Standard ANSI/NSF 60, Drinking Water Treatment Chemicals - Health Effects", October 6, 2015, Document Number NSF/ANSI 60-2015 ([NSF Web Site](http://www.nsf.org/services/by-industry/water-wastewater/municipal-water-treatment/nsf-ansi-standard-61)).

¹ NSF/ANSI Standard 61: Drinking Water System Components -- Health Effects are both American National Standards, which means that the NSF Standards and the processes used to develop them conform to ANSI's requirements for voluntary consensus standards (<http://www.nsf.org/services/by-industry/water-wastewater/municipal-water-treatment/nsf-ansi-standard-61>).

2.2.5 Grouting the Borehole

The borehole should be pressure grouted using a tremie pipe as the drilling stem is removed. The sealant should be applied in one continuous procedure to prevent segregation, dilution, and bridging (Aller et al., 1991). The pipe should be in constant contact with the sealant to prevent air pockets from forming. The borehole should be sealed from the bottom up to the frost line (approximately two to three feet from the surface). The overflowing grout should be regularly evaluated as it reaches the surface. When the observed material is similar to that being pumped in, this stage of the sealing is considered complete. Wells sealed in-situ should be sealed from the bottom up to approximately three feet from the surface.

- Small diameter wells or boreholes (<2 inches) may present special challenges. A small diameter (3/4 inch) grout pipe can be used; however, high pumping pressures or less viscous materials may be necessary (ASTM D5299-99(2012)e1). Grouting machines are available for use with small diameter wells. A grouting machine reduces problems of bridging and incomplete seals associated with adding materials from the ground surface.
- When sealing wells that have two or more saturated zones or in flowing wells, it may be necessary to use a packer assembly. An inflatable packer can be placed at the top of the producing water zone to stop or restrict flow. The borehole can be sealed by pressure grouting from the bottom of the hole to the top of the packer. The packer can then be deflated and the grouting process continued.
- If dry sealant is introduced by gravity pouring, care must be taken that bridging does not occur. This can be accomplished by slowly adding the grout and stopping periodically (e.g., every five feet) to measure, tamp the grout and add water to hydrate. The amount of added water should be in accordance with manufacturer specifications. Coarse grade or bentonite pellets should be poured over a wire mesh to remove fines.

2.2.6 Completion of Borehole

The grout plug should be inspected 24 hours after installation to check for settling; grout should be added if needed. If the well is sealed in-place, the casing should be cut off approximately three feet below ground level and a PVC or stainless steel cap should be emplaced. The boring should be grouted to within two to three feet from the surface with appropriate material. Monitoring wells sealed in-place should be marked with a piece of metal to allow for location by a metal detector or magnetometer (Aller et al., 1991).

2.2.7 Final Surface Seal

The remaining area above the plug should be completed in a manner that is compatible with the site. For example, its top can be covered with one to two feet of soil if vegetative growth is desired. If the area is to be surfaced, then the final seal can be completed with asphalt or concrete.

2.3 DOCUMENTATION

2.3.1 Report Submittal to Ohio EPA

Proper sealing of monitoring wells/boreholes should be documented and reported to the Ohio EPA division regulating the site. The information should include, at a minimum:

- Identification (e.g., registration number, location, owner, and any other features).
- Well construction details.
- Date, time, person responsible, and contractor/consultant performing the work.
- Authority under which sealing was performed.
- Procedures and materials used (including predicted volume of grout, volume of grout used, and an explanation if any discrepancy exists between these values).
- Method/procedures for disposal of any contaminated materials. (Disposal of any contaminated material must be in accordance with any federal, state, or local regulations.)

2.3.2 Report Submittal to Ohio Department of Natural Resources (ODNR)

The Ohio Revised Code 1521.05(C) requires that a well sealing report be filed with the Ohio Department of Natural Resources (ODNR). Figure 9.1 is an example of the form. It can be obtained from ODNR, Division of Water (614-265-6739).

WATER WELL SEALING REPORT e-FORM
OHIO DEPARTMENT OF NATURAL RESOURCES
 Division of Soil and Water Resources
 2045 Morse Road, Bldg B
 Columbus, OH 43229-6893
 Voice: (614) 265-6740 Fax: (614) 265-6767

LOCATIONCounty GEAUGA Township PARKMAN Section No. _____ Lot No. _____Owner E. J. FUDDAddress of Well Location 1234 NOTKNOWN RD.City ANYTOWN Zip Code 00000-1230Well Location Description (120 Characters) 1/2 mile south of Maindrag on west side of Notknown.

Location of Well in either: State Plane OR Latitude/Longitude

N S X Y Latitude 41.41234 Longitude -81.01234

Elevation of Well 1022.00 ft. Datum Plane: NAD27 NAD83Source of Coordinates: GPS Survey Other _____Source of Elevation: GPS Survey Other _____**WELL IDENTIFICATION** ODNR Well Log Number 123456 Project Well ID _____**MEASURED CONSTRUCTION DETAILS**Date of measurements 08/06/2012Depth of Well 106 ft. Static Water Level 83 ft.Borehole Depth 106 ft. Borehole Diameter _____ in.Casing Diameter 5.63 in. Casing Length 27 ft. Casing Type steel**SEALING PROCEDURE**

Placement:	Sealing Material	Volume/Weight Used <small>Units Required</small>	Placement Method
From <u>0</u> ft. To <u>106</u> ft.	<u>Bentonite/polymer slurry</u>	<u>115</u> gals/250 Lbs	<u>Pumped w/tremie pipe</u>
From _____ ft. To _____ ft.	_____	_____	_____
From _____ ft. To _____ ft.	_____	_____	_____

Condition of Casing good Was Casing Removed? Yes or No

(check one)

If casing **Not Removed**, was it Perforated? Yes or No Perforations: From _____ ft. To _____ ft.

(check one)

Date Sealing Performed 08/08/2012Comments/Reason for Sealing VERY HIGH IRON LEVELS WHICH KEEPS SEALING OFF THE WATER**CONTRACTOR**Name ACME DRILLING COMPANY ODH Registration # 9876Address 1234 MAIN ST.City/State/Zip SOCKERDOWNE, OH 56789e-Signature W. E. COYOTE Filed electronically on 08/06/2012

I hereby certify the information given is accurate and correct to the best of my knowledge.

Completion of this form is required by section 1521.05, Ohio Revised Code - file within 30 days after completion of sealing.
 Distribute additional copies to: Customer, Driller and Local Health Department.

Figure 9.1 Example of an official Ohio water well sealing report form
 (Contact ODNR, Division of Water for Form. 614-265-6739).

3.0 REFERENCES

- Aller, L., T. W. Bennett, G. Hackett, R. J. Petty, J. H. Lehr, H. Sedoris, D.M. Nielsen, and J. E. Denne. 1991. Handbook of Suggested Practices for the Design and Installation of Ground Water Monitoring Wells. Environmental Monitoring Systems Laboratory, Office of Research and Development, U.S. Environmental Protection Agency. Las Vegas, Nevada. EPA/600/4-89/034. (In cooperation with the National Water Well Association).
- American Society for Testing Materials. Method D5299-99(2012)e1. Standard Guide for Decommissioning of Ground Water Wells, Vadose Zone Monitoring Devices, Boreholes, and other Devices for Environmental Activities. American Society for Testing Material Standards. Philadelphia, Pennsylvania.
- American Water Works Association. 1984. Appendix I: Abandonment of Test Holes, Partially Completed Wells, and Completed Wells. American Water Works Association Standard for Water Wells. American Water Works Association. Denver, Colorado. pp. 45-47.
- Christman, M., C.H. Benson, T.B. Edil. 2002. Geophysical Study of Annular Well Seals. Ground Water Monitoring and Remediation. Volume 22, Number 3, pp. 104-12.
- Edil, T.B., M.M.K. Chang, L.T. Lan, T.V. Riewe. 1992. Sealing Characteristics of Selected Grouts for Water Wells. Ground Water. Volume 30, Number 3, pp. 351-361.
- Gordon, D. L. and D. Koch. 1988. Guidelines for Plugging Abandoned Water Wells. Iowa Department of Natural Resources, Geological Survey Bureau. Technical Information Series 15. Iowa City, Iowa.
- Kraemer, C. A., J. A. Shultz, and J. W. Ashley. 1991. Monitoring Well Post-Installation Considerations. In: D. M. Nielsen (editor), Practical Handbook of Ground-Water Monitoring. Lewis Publishers, Inc. Chelsea, Michigan. pp. 333-363.
- National Science Foundation Standard. 2015. ANSI/NSF 60, "Drinking Water Treatment Chemicals - Health Effects", October 6, 2015, Document Number NSF/ANSI 60-2015.
- National Science Foundation Standard. 2015. ANSI/NSF 61, "Drinking Water System Components -- Health Effects", March 29, 2015, Document Number NSF-ANSI 61-2015
- Ohio Environmental Protection Agency Division of Environmental Response and Revitalization SIFU's FSOP 1.9 Boring and Monitoring Well Decommissioning, September 2015
- Ohio Water Resources Council. State Coordinating Committee on Ground Water. 2015. Regulations and Technical Guidance for Sealing Unused Water Wells and Boreholes
- Renz, M. E. 1989. In-Situ Decommissioning of Ground Water Monitoring Wells. Water Well Journal. Vol. 43, No. 5, pp. 58-60.
- Smith, A. Stuart. 1994 Well & Borehole Sealing: Importance, Materials, Methods and Recommendations for Decommissioning. Ground Water Publishing Co. Dublin, Ohio.

Division of Drinking and Ground Waters

**Technical Guidance Manual for Ground Water
Investigations**

Chapter 10

Ground Water Sampling



February 2006

Governor : Ted Strickland
Director : Chris Korleski



**TECHNICAL GUIDANCE
MANUAL FOR
GROUND WATER INVESTIGATIONS**

**CHAPTER 10
GROUND WATER SAMPLING**

February 2006
(Revision 1)

Ohio Environmental Protection Agency
Division of Drinking and Ground Waters
P.O. Box 1049 50 West Town Street, Suite 700
Columbus, Ohio 43216-1049
Phone: 614-644-2752
<http://www.epa.state.oh.us/ddagw>

PREFACE

This document is part of a series of chapters incorporated in Ohio EPA's *Technical Guidance Manual for Hydrogeologic Investigations and Ground Water Monitoring* (TGM), which was originally published in 1995. DDAGW now maintains this technical guidance as a series of chapters rather than as an individual manual. These chapters can be obtained at <http://www.epa.state.oh.us/ddagw/tgmweb.aspx>.

The TGM identifies technical considerations for performing hydrogeologic investigations and ground water monitoring at potential or known ground water pollution sources. The purpose of the guidance is to enhance consistency within the Agency and inform the regulated community of the Agency's technical recommendations and the basis for them. In Ohio, the authority over pollution sources is shared among various Ohio EPA divisions, including the Emergency and Remedial Response (DERR), Hazardous Waste Management (DHWM), Solid and Infectious Waste (DSIWM), and Surface Water (DSW), as well as other state and local agencies. DDAGW provides technical support to these divisions.

Ohio EPA utilizes *guidance* to aid regulators and the regulated community in meeting laws, rules, regulations, and policy. Guidance outlines recommended practices and explains their rationale. The Agency may not require an entity to follow methods recommended by this or any other guidance document. It may, however, require an entity to demonstrate that an alternate method produces data and information that meet the pertinent requirements. The procedures used usually should be tailored to the specific needs and circumstances of the individual site, project, and applicable regulatory program, and should not comprise a rigid step-by-step approach that is utilized in all situations.

ACKNOWLEDGMENTS

This guidance was developed by Ohio EPA's Division of Drinking and Ground Waters (DDAGW). The following are acknowledged for the preparation of this document.

Lisa Koenig, DDAGW-CO who had primary responsibility for researching and revising the updated version. She also provided significant input into the 1995 version. **Dan Tjoelker** (now in DERR-CO) was primarily responsible for drafting the 1995 document.

Sydney Poole, DDAGW-CO, and **Jeff Patzke**, DDAGW-CO, who researched and wrote various portions of the document.

Jeff Martin (now in DSIWM-CO) who completed an in-depth review of the revised document.

Atuir Rahman & Pete Sokoloski (DDAGW-NEDO); **Erik Hagen** (DHWM-CO), **Rich Bendula** (DDAGW-SWDO), **Greg Brown** (DDAGW-SWDO); **Ken Brock**, **Tim Fishbaugh**, **Dale McLane**, **Randy Skrzyniecki**, and **John Weaver** (DDAGW-NWDO) and **Mike Bondoc** (DDAGW-CDO) who provided comments.

Jeff Patzke, DDAGW-CO, who serves as editor and project coordinator for the Technical Guidance Manual

The Ohio EPA would also like to thank the numerous people who provided input during the development of the 1995 document. The comments and recommendations from the DDAGW-District Offices, and other Ohio EPA Divisions, state and federal agencies, private consultants, and regulated community were greatly appreciated.

TABLE OF CONTENTS

PREFACE.....	10-ii
ACKNOWLEDGMENTS.....	10-iii
TABLE OF CONTENTS.....	10-iv
TECHNICAL CHANGES FROM THE FEBRUARY 1995 TGM.....	10-vi
POTENTIAL EFFECTS ON SAMPLE QUALITY.....	10-2
EFFECTS CAUSED BY WELL CONSTRUCTION AND DEVELOPMENT.....	10-2
EFFECTS CAUSED BY CHANGE IN SAMPLE ENVIRONMENT.....	10-2
Aeration/Oxidation.....	10-2
Pressure Differences.....	10-2
Temperature Differences.....	10-3
EFFECTS DUE TO SAMPLING TECHNIQUE.....	10-3
PLANNING AND PREPARATION.....	10-3
WRITTEN PLAN.....	10-3
EVENT PLANNING AND PREPARATION.....	10-5
Preparation Procedures.....	10-5
General Supply and Equipment Checklist.....	10-5
PARAMETER SELECTION.....	10-6
Parameters to Characterize General Quality.....	10-6
Parameters to Characterize Contamination.....	10-6
SAMPLING AND PURGING EQUIPMENT.....	10-7
CRITERIA FOR SELECTION.....	10-7
Device Characteristics.....	10-7
Site/Project Characteristics.....	10-8
TYPES OF EQUIPMENT.....	10-9
Grab Samplers.....	10-9
Bladder Pumps.....	10-11
Electrical Submersible Pumps.....	10-12
Gas-Driven Piston Pumps.....	10-13
Suction Lift Pumps.....	10-13
Passive Diffusion Samplers.....	13
Other Devices.....	10-14
Use of Packers.....	10-15
FIELD PROCEDURES.....	10-17
FIELD CONDITIONS.....	10-17
WELL INSPECTION AND PREPARATION.....	10-17
WELL MEASUREMENTS.....	10-18
Detection of Organic Vapors and Gases.....	10-18
Water Level.....	10-18
Well Depth.....	10-19
Detection of Immiscible Liquids.....	10-23
SAMPLING IMMISCIBLE LIQUIDS.....	10-23
SAMPLING AND PURGING PROCEDURES.....	10-24
Field Measurements of Ground Water Indicator Parameters.....	10-24
Volumetric Purging & Sampling.....	10-27
Low-Flow Purging/Sampling.....	10-29
Minimum/No Purge Sampling.....	10-30
Purge to Dryness & Sampling.....	10-32

Passive Diffusion Sampling	10-33
FILTRATION	10-33
Deciding When to Filter	10-34
Recommended Procedure/Equipment When Filtering is Necessary	10-35
SAMPLE HANDLING, PRESERVATION, CONTAINERS, AND SHIPPING.....	10-36
Sample Acquisition and Transfer	10-37
Sample Splitting	10-39
Sample Preservation.....	10-39
Containers and Sample Labels	10-40
Shipping	10-42
DISPOSAL OF PURGED WATER.....	10-43
DECONTAMINATION PROCEDURES.....	10-43
DOCUMENTATION	10-44
Field Sampling Logbook	10-44
Chain-Of-Custody	10-45
Sample Analysis Request Sheet.....	10-46
GROUND WATER SAMPLE ANALYSIS.....	10-50
SELECTION OF ANALYTICAL METHOD.....	10-50
LABORATORY QUALITY ASSURANCE/QUALITY CONTROL (QA/QC).....	10-50
REFERENCES.....	10-52

TECHNICAL CHANGES FROM THE FEBRUARY 1995 TGM

The Ohio EPA Technical Guidance Manual for Hydrogeologic Investigations and Ground Water Monitoring (TGM) was finalized in 1995. This guidance document represents an update to Chapter 10 (Ground Water Sampling). Listed below are the major technical changes from the 1995 version of Chapter 10.

1. Modified the Parameter Selection section to make it more generic and less slanted to a particular regulatory program.
2. Deleted the Sampling Frequency section. Frequency pertains more to the overall monitoring program and will be discussed in future chapters. Information on sampling frequency can be found in Barcelona et al., 1989.
3. Added language discouraging the use of bailers. Provided more guidelines on how bailing, if used, should be completed.
4. Added information on submersible pumps and types that appear acceptable for obtaining a ground water sample.
5. Added information on low flow purging/sampling, diffusion bag sampling, and minimum/no purge sampling.
6. Corrected the stabilization parameter criteria for purging a well. The 1995 document erroneously indicated that the criteria for stabilization for all parameters was 10%. Note that a 10% variation pH would be a significant change. For pH, the stabilization has been corrected to ± 0.1 units. Stabilization criteria have been provided for specific conductance, oxidation-reduction potential, turbidity, dissolved oxygen and temperature based on U.S. EPA guidance and peer-reviewed.
7. Modified the decontamination process. This included removing the reference to using ASTM Type II water for decontaminating equipment.
8. Changed the turbidity criterion from 5 to 10 NTU. Added a recommendation to filter ground water samples using media with 5 micron pore size (when filtration is appropriate and site conditions do not dictate a different size.)
9. Preservatives and holding times: Made the table more generic and based on U.S. EPA Federal Register 40, Volume 69, No. 66, April 6, 2004.
10. Added web addresses to various sites (e.g., U.S. EPA-approved analytical methods).
11. Added an appendix that provides additional considerations when sampling a water supply well.

CHAPTER 10

GROUND WATER SAMPLING

This chapter summarizes procedures for collecting ground water samples from monitoring wells. It focuses on the planning and preparation prior to sampling, types of sampling and purging equipment, field procedures, quality control sampling, and documentation to ensure that samples represent the quality of water obtained from the sampled interval. When selecting protocol, it is important to understand the impacts that removing water from a well can have on the chemistry of the water. Therefore, impacts to sample integrity are also discussed. The chapter also provides some information on the selection of analytical methods and laboratory quality assurance.

The primary objective of most ground water monitoring programs is to collect a sample that represents the in-situ ground water quality. However, the working definition of “representative” is not always the same for all programs. For example, those interested in characterizing ground water for the purpose of evaluating it as a potable water supply may be more interested in volumetric-averaged concentrations in the ground water zone (Nielsen and Nielsen, 2006). Monitoring programs may also be designed to determine “worst-case” conditions. Therefore, prior to starting any monitoring program, the data quality needs should be determined to ensure the collection of data that are of adequate quality to support decision making (See U.S. EPA, Data Quality Objectives Guidance, 2000).

The goal in sample collection is to sample in a manner that results in the least disturbance or change in the chemical and physical properties of the water. The guidelines provided here are intended to assist in choosing the most appropriate methods. Site-specific circumstances may require alternative approaches that are not specified. In these cases, the appropriate regulatory authority should be contacted to establish an acceptable approach. In addition, rules may specify issues such as frequency of sample collection, filtration, frequency and accuracy of water level measurements, and parameters for analysis. Requirements for documentation of field and laboratory procedures may also be specified. Appropriate divisions within Ohio EPA should be consulted when planning a ground water sampling program.

The choice of equipment and methodology should be based on an understanding of the hydrogeology of the area and the purpose of the data collection. Each technique has disadvantages and advantages; therefore, there is no best overall method. Because different techniques may yield different results, the best approach is to be consistent throughout an investigation to facilitate the comparison of data values over time (ASTM D4448-01). When necessary, changes in sampling strategies should be discussed with Ohio EPA prior to implementation.

Although the chapter is intended specifically for the sampling of conventional monitoring wells, the procedures may be useful for other types of ground water sampling, such as direct push technology and water supply wells. Additional information on direct push can be found in Chapter 15-Use of Direct Push Technologies for Soil and Ground Water Sampling. Additional considerations for sampling a water supply well can be found in Appendix A of this chapter.

POTENTIAL EFFECTS ON SAMPLE QUALITY

Many aspects of the sampling process can affect the chemistry of ground water when it is being collected. As a result, a sample may not represent the actual quality of the ground water. Therefore, the potential effects need to be considered in any sampling program.

EFFECTS CAUSED BY WELL CONSTRUCTION AND DEVELOPMENT

The chemistry of a ground water sample may be affected by poor well construction and/or development. Wells that do not have proper filter packs or are improperly grouted may have water that does not represent the quality of ground water flowing through their intakes. This may be due to grout contamination or water seeping down the casing from the surface or other ground water zones. If a well has not been properly developed (See Chapter 8 - Monitoring Well Development, Maintenance, and Redevelopment), then sample quality may be affected by the sediments in the well.

EFFECTS CAUSED BY CHANGE IN SAMPLE ENVIRONMENT

Transfer of ground water from *in-situ* to atmospheric conditions can alter its chemistry significantly unless proper sampling techniques are used. Aeration/oxidation, pressure, and temperature changes are three major causes of chemical alteration.

Aeration/Oxidation

Upon exposure to the atmosphere, the redox state of ground water samples increases due to the addition of oxygen. Dissolved species such as iron (Fe), manganese (Mn), arsenic (As), and cadmium (Cd) may be oxidized from a reduced state (Gillham et al., 1983), which can cause them to precipitate from solution. The oxidation of Fe is particularly important for sample stability. Ground water may contain high concentrations of dissolved Fe due to anoxic (low oxygen) subsurface conditions. Upon exposure, it can oxidize rapidly and precipitate ferric hydroxide, resulting in a decrease in pH that may alter sample integrity further ($4\text{Fe} + 10\text{H}_2\text{O} \rightarrow \text{Fe}(\text{OH})_3(\text{s}) + 8\text{H}^+$). Ferric hydroxide is known to remove contaminants from solution including, but not limited to, copper (Cu), zinc (Zn), cobalt (Co), cadmium (Cd), arsenic (As) and lead (Pb). While it may often be difficult to prevent redox changes, acidification of samples being analyzed for metals will prevent metals from precipitating.

Pressure Differences

Pressure changes caused by the release of ground water into a well may cause shifts in chemical equilibrium. Ground water may have high partial pressures of carbon dioxide (CO₂) gas and, upon exposure, degas CO₂. This is known to cause increases in pH by up to 0.5 to 1 standard units and may cause various metals to dissolve or precipitate. If volatile organic compounds (VOCs) are present, sudden pressure changes cause their volatilization. This will result in a negative bias with respect to true VOC concentration.

Temperature Differences

The temperature of a sample may change because of differences between ambient air and subsurface conditions. A primary concern is an increase in temperature, which may kinetically favor redox reactions and promote increased biodegradation and volatilization.

EFFECTS DUE TO SAMPLING TECHNIQUE

The method and design of the sampling device potentially can alter samples. Tools that allow air to contact ground water (see equipment section) can potentially aerate samples, as discussed above. Devices can leach contaminants into samples or sorb contaminants from them. Also, improper decontamination of equipment can alter samples.

PLANNING AND PREPARATION

The success of any ground water sampling event hinges on the planning and preparation conducted prior to entering the field. The sampling procedures should be documented in a written plan. What should be included in the written plan is summarized below. Procedures and event planning and preparation should be evaluated carefully and be appropriate for the associated Ohio EPA program and the intended use of the sampling data. This should also include an evaluation of the parameters selected.

WRITTEN PLAN

Written, detailed, site-specific protocol should be developed to document sampling and analysis procedures. The protocol can be incorporated into a single, stand-alone document (sometimes called a sampling and analysis plan) or can comprise a section of a more comprehensive document. Protocol should provide sufficient detail for personnel to properly operate equipment and perform procedures and techniques in a manner that will generate representative data. The circumstances and conditions under which procedures and techniques will be implemented should be clearly described.

The submittal, format, and/or disposition may or may not be specified by rule. In all cases, the plan or other protocol should meet all requirements of the associated Ohio EPA program and provide data appropriate for the investigative purposes. In general, a plan may include (at a minimum) the components listed in Table 10.1

Table 10.1		GENERAL COMPONENTS¹ OF A GROUND WATER SAMPLING AND ANALYSIS PLAN (SAP)	
Parameter selection			
Sampling frequency			
Field procedures prior to sampling ground water: <ul style="list-style-type: none"> -well inspection -water level measurements (including meter type and level of accuracy) -total depth of well -detection and sampling of immiscible liquids 			
Well purging, including but not limited to: <ul style="list-style-type: none"> -methods -equipment -criteria completion -disposal of water 			
Field measurements of ground water: <ul style="list-style-type: none"> - parameters (e.g., pH, temperature, and conductivity) - description and calibration of field equipment - description of field analysis procedures 			
Sample withdrawal: <ul style="list-style-type: none"> - methods - equipment 			
Sample handling:			
<ul style="list-style-type: none"> - order of collection - preservation (type and when/how added) - holding times 		<ul style="list-style-type: none"> - filtration² - containers with labels - shipping 	
Decontamination procedures			
Documentation: <ul style="list-style-type: none"> - field logbook or sampling documentation forms³ - standardized chain-of-custody forms - sample analysis request sheet - field QA/QC samples 			
Laboratory analysis: <ul style="list-style-type: none"> - analytical methods - detection limits - laboratory QA/QC samples - description of data validation methods - reporting requirements and format 			

¹ Additional components may be necessary on a site-by-site basis.

² Check whether the regulatory program allows filtering of ground water samples. Note that the Ohio solid waste regulations do not allow filtering at municipal landfills.

³ See page 10-48 for items that may need to be included.

EVENT PLANNING AND PREPARATION

Before any sampling begins, planning and preparation should be a high priority. All personnel should be familiar with site-specific written protocol and trained in the proper use of the equipment. All equipment and paperwork should be organized. Instruments should be in working order and properly decontaminated. Field logs, sheets, or other documents used to record notes should be organized. Arrangements with the laboratory should be made to ensure that samples can be handled and analyzed within the required holding times and to obtain labels, appropriate containers, and preservatives. The following are general checklists for preparation procedures and equipment:

Preparation Procedures

- Determine sampling date, time, and location.
- Estimate total sampling and travel time to insure appropriate lab arrangements.
- Determine the number and type of analyses needed from each location.
- Determine purge water management practices.
- Determine decontamination procedures.
- Determine safety procedures.
- Determine the number of field, equipment, and trip blanks and duplicates needed.
- Determine sample volumes needed, total number of samples, and container type.
- Review the construction, sampling history and recharge rate of each well.
- Be aware of any nearby production wells that may affect measured water levels.
- Determine samples to be filtered (if appropriate) and secure appropriate equipment.
- Check to see that the equipment is working properly.
- Calibrate all instruments and calculate bailer volume (if necessary).
- Collect containers and all necessary preservatives if containers not pre-preserved.
- Review and understand all transportation and chain-of-custody procedures.

General Supply and Equipment Checklist

- SAP.
- Keys to locks on wells.
- Map of site and well locations.
- Field notebook, logbook, and/or field sampling forms.
- Indelible marking pens.
- Appropriate lab analysis and chain-of-custody forms.
- Preservatives.
- Filtration equipment.
- Ice.
- Coolers for ice and samples.
- Purging and sampling devices.
- Appropriate tubing.
- Appropriate sample containers and labels.
- Field monitoring meters (e.g., water level, pH, specific conductance, temperature, etc.).
- Calibration instructions and standard testing solutions for field monitoring equipment

- Calibrated bucket (to determine volume of purged water).
- Tool box.
- Extra batteries.
- Safety equipment.
- Calculator.
- Plastic sheeting for ground cover.
- Decontamination solutions and equipment.
- Flashlight.
- Photoionization detector (PID) or organic vapor analyzer (OVA).
- Equipment for detecting immiscibles (e.g., interface probe or clear bailer).
- Contact information for site, facility, and laboratory.
- Emergency contact information.

PARAMETER SELECTION

Parameter selection depends on whether the purpose of sampling is to quantify the general quality of the ground water or identify the presence of any contamination.

Parameters to Characterize General Quality

Parameters used to characterize general quality can include: pH, alkalinity, total dissolved solids (TDS), turbidity, dissolved oxygen, oxidation/ reduction potential (ORP), fluoride (F^-), hydrogen sulfide (H_2S), total hardness and non-carbonate hardness, specific conductance, chloride (Cl^-), nitrate (NO_3^-), sulfate (SO_4^{2-}), phosphate (PO_4^{3-}), silicate (SiO_2), sodium (Na^+), potassium (K^+), calcium (Ca^{2+}), magnesium (Mg^{2+}), ammonium (NH_4^+), total iron (Fe), and manganese (Mn). The results can provide an overall picture of ground water geochemistry that is useful to site characterization. For example, an understanding of geochemistry can help in determining chemical species present (e.g., AsO_3^{2-} versus AsO_4^{3-}) and mobility in the subsurface. Certain parameters (e.g., anions, cations, pH, TDS, specific conductance) are helpful in evaluating releases of inorganic contaminants, while other parameters (chloride, iron, nitrate, sulfate, dissolved oxygen, ORP, and alkalinity) can be used to evaluate changes in ground water chemistry caused by the release and biodegradation of organic contaminants. Regulated entities (such as municipal or hazardous waste landfills) may be required to establish a sampling program that may include some the above-mentioned parameters.

Parameters to Characterize Contamination

When ground water contamination is known, suspected, or being investigated as part of a monitoring program, parameters specific to the waste material, history of the site/facility, or chemicals of concern (COCs) usually are necessary. Rules may also dictate specific parameters. When ground water contamination is known or suspected, entities may be required to monitor additional site-specific parameters⁴.

⁴ It is suggested that, in some cases (e.g., characterizing known ground water contamination), that the laboratory be requested to report all constituents listed in a methods target analyte list whether they are detected or quantified or not. This ensures that breakdown products are also considered.

Past waste constituents and handling practices should be considered. Because waste released to the environment may chemically change through time, potential breakdown products should be considered. If accurate disposal records are available and waste constituents are well documented, the list of parameters can be relatively limited. The list should be more extensive if handling practices are poorly understood. Monitoring suites of parameters (e.g., volatiles, semi-volatiles, metals, etc.) may be necessary when specific waste constituents are not known. Where rule/policy allows, lists may be narrowed as the investigation progresses and waste constituents and chemicals of concern become better defined.

SAMPLING AND PURGING EQUIPMENT

A variety of sampling and purging equipment is available. Depending on the situation, all types have advantages and disadvantages. There is no device that can be used in every situation. Site-specific hydrogeology, geochemistry, types of contaminants, and well design may affect equipment performance. Ultimately, the ideal scheme should employ inert material, should not subject samples to negative pressures or high positive pressures, and should minimize exposure of samples to the atmosphere (ASTM, Method D4448-01).

CRITERIA FOR SELECTION

In general, the choice of a device should be based on the ***characteristics of the device*** in combination with the ***characteristics of the site/project***. The following paragraphs discuss these characteristics and the criteria that should be considered.

Device Characteristics

Characteristics of devices are:

- ***Device composition*** - The chosen device should have sample-contacting parts made of "inert" materials that limit the potential for bias through sorption or leaching of contaminants, degradation, or corrosion. For components requiring rigid material (casing, screen, bailers etc.), the acceptable materials are fluorocarbon polymer (e.g., Teflon®), stainless steel (316 and 304), and PVC. Disposable bailers can also be composed of polyethylene and polypropylene. When sampling for organics, pump tubing should be composed of fluorocarbon polymer, or fluorocarbon polymer-lined polyethylene. Polyethylene tubing is also acceptable for sampling for inorganics (U.S.G.S., U.S.EPA, 2002, ASTM 4088).
- ***Device design and technique of use*** - The device should deliver samples with minimal atmospheric exposure, should not apply negative pressures (vacuum), and should limit agitation, both in the well and in the transfer process. Furthermore, the tool should not introduce air or non-inert gas into samples as part of its lift mechanism.
- ***Flow rate control and capacity*** - When pumps are used, low flow rates are desirable to limit agitation and turbulent flow, especially for VOCs (Barcelona et al., 1985, U.S. EPA, 1986a). The ability to maintain a steady low flow varies significantly. If the device is

being used for purging and sampling, then it should be capable of being operated at variable flow rates suitable for both applications. Flow control that involves "valving" should be avoided, since it can cause pressure changes and subsequent sample alteration. Instead, a mechanism that directly controls the rate (i.e., a rheostat to vary the power supplied to an electric submersible pump) should be utilized.

- **Operation and Maintenance** - The device should be easy to operate and maintain. If personnel are not properly trained, the margin of potential error is greater. The device should be designed for in-field maintenance. Mechanically simple equipment that can be easily repaired with inexpensive, replaceable parts is preferable. If decontamination is necessary, the device should be easy to decontaminate. Devices that are constructed to minimize the surface area contacting ground water samples and that are easy to disassemble and reassemble are best. Use of dedicated or disposable equipment at each well or sampling point eliminates the need for decontamination, saving valuable field time and reducing the potential for cross contamination of samples.
- **Device reliability, durability, and portability** - The device should operate reliably for extended periods and be able to withstand a variety of chemical and physical environments. Dedicated equipment may need to withstand extended contact with ground water and any existing contamination. Equipment that is transported into locations where access is limited should be sufficiently portable. Excess weight and volume of battery packs, generators, air compressors, tubing, etc. can limit portability.
- **Capital, operation, and maintenance costs** - These should be considered, however, they should not be overriding factors. Obtaining a sample that is representative of site conditions should be of more importance than cost, particularly when the costs of well installation, chemical analysis, and possible litigation resulting from discrepant analytical results are considered. These costs often far outweigh equipment purchase costs (Nielsen and Yeates, 1985).

Site/Project Characteristics

Characteristics of sites/projects that should be considered are:

- **Monitoring Well Diameter** - The device should be compatible with the diameter of the well. Most sampling equipment is not designed to be used in all wells.
- **Well Obstructions or Constrictions** - These can hinder the entry and retrieval of sampling equipment. For example, casing joints may not be flush and could prevent insertion. Also, a well that is not plumb can restrict access.
- **Depth to the Sampling Interval** - Deeper zones require greater lift capacity and generally increase sampling times, which may limit the desirability of labor-intensive devices. Options generally become limited as depth increases.
- **Parameters of Interest** - The suitability of various devices may depend on the parameters of greatest concern. Some devices perform better for inorganics, while some are more suitable for VOCs.

- **Presence of Non-Aqueous Phase Liquids (NAPLs)** - The equipment should be capable of detecting the presence of either light or dense NAPLs if they are potentially present.
- **Saturated Zone Characteristics and Ground Water Chemistry** - The equipment should be appropriate for the saturated zone yield, the screen or open borehole length, the presence of stratification (causing vertical variation in yield) within the screened saturated zones, and the available water column in the well. Additionally, the sampling equipment should be compatible with ambient ground water chemistry, unusually low (<5.5.U.) or high (>9.5.U.) pH conditions, the presence of gas, etc.
- **Temporal (Seasonal) Variations** - The sampling equipment should be operable over seasonal variations in saturated zone temperature, yield and water level elevation.

TYPES OF EQUIPMENT

The following is a discussion of some of the sampling equipment available. Table 10.3 (at the end of this section) summarizes the recommended devices. Devices not mentioned may be acceptable if they are peer-reviewed and have been demonstrated to be capable of collecting representative samples. For additional information, see ASTM D4448-01, ASTM D6634-01, Barcelona et al. (1985), Nielsen and Yeates (1985), Electric Power Research Institute (EPRI, 1985, 1987), Gillham et al. (1983), Nielsen and Nielsen (2006), Parker (1994), Pohlman and Hess (1988), and U.S. EPA (1992), Yeskis and Zavala (2001).

Grab Samplers

Grab samplers collect a sample at discrete depths without being pumped or lifted to the surface by gas or air. Grab samplers commonly used to collect ground water include bailers and syringe samplers.

Bailers

Bailers are the most portable of all sampling devices. A bailer can be constructed of virtually any rigid or flexible material, including materials that are inert to chemical contaminants. For sampling ground water, acceptable compositions include Teflon®, stainless steel, PVC, polyethylene, and polypropylene. Disposable bailers are often the choice of the environmental industry. The cord used to raise and lower the bailer should be of non-reactive substance (e.g., stainless steel, teflon-coated wire/rope, polypropylene).

Bailers are readily available in a variety of diameters. Their diameter should be 75% (or less) of the inside diameter of the well casing to allow for adequate clearance.

There are several types of bailers (ASTM D 6634-01, D6699-01):

- A **top filling** bailer is designed such that water flows through its top. Because of the agitation of the sample, this bailer is only appropriate for sampling light, non-aqueous phase liquids (LNAPL).

- A **single check** valve bailer (open bailer) has a valve at its bottom that seals the sample chamber when the bailer is withdrawn.
- A **double check** valve bailer (point source bailer) is designed to sample discrete zones in a water column. Water flows through valves at both ends as the bailer is lowered. When the desired level is reached, the bailer is pulled back, both valves close, and water from the interval is retained. However, if appropriate procedures are not carefully followed, samples collected may not be representative of the depth interval of interest. The double check valve bailer is also effective in collecting dense, non-aqueous phase liquids (DNAPLs).
- A **differential pressure** bailer consists of a sealed canister body with two small diameter tubes of different heights. The bailer is rapidly lowered into the well. When the descent has stopped, differences in hydrostatic pressure between the two tubes allow the bailer to fill through the lower tube as air is displaced through the upper tube. This minimizes the exposure of the sample to air, especially if the bailer is fitted with internal 40 ML vials for direct sample bottle filling. However, because the bailer is lowered rapidly, it will agitate the water column.

The use of bailers is discouraged. Current research indicates that bailers generally are not the best available technology to collect ground water samples. Various studies (laboratory and field) have been conducted to investigate the potential differences in VOC analytical results between samples collected by bailing and low-flow techniques. Some studies have demonstrated that levels of VOCs in samples obtained with bailers are statistically lower than in samples obtained with other devices (Imbrigiotta et al. 1988; Tai et al. 1991). In addition, bailing can cause increased turbidity (Puls and Powell, 1992; Puls et al., 1992; Backhus et al., 1993). In contrast, a literature survey by Parker (1994) found that bailers can recover representative samples under certain circumstances and that loss of volatile and oxidizable analytes can be reduced by careful use of bottom-emptying devices. In addition, a Wisconsin Department of Natural Resources study comparing results from a bottom-emptying bailer and a Keck® helical-rotor pump operated at low flow pumping rates determined that differences in VOC concentrations were relatively small (Karkins, 1996).

Though current research indicates that bailers generally are not the best available technology, they may be the only practicable option for sampling some ground water zones. Bailers may be preferred where the water column is small or the saturated zone is very deep. They may be preferred when concentrations of contaminants are extremely high because they are easier to decontaminate and are less expensive to replace than pumps. Disposable bailers eliminate the need to decontaminate. Personnel sampling with bailers need to be properly trained since the results are highly dependent on the skill, care, and consistency of the operator. This training should be documented in the SAP.

If bailers are used, **double check valve bottom-draining** bailers are recommended. This allows for lessened sample disturbance during transfer to the container. The bailer should be composed of Teflon®, stainless steel, PVC, polyethylene, or polypropylene. Either fluorocarbon polymer-coated or colorless (white) polypropylene cord should be used to lower and raise the bailer. Polypropylene cord is inexpensive enough to be discarded after one use. A bailer should always be lowered and raised slowly to minimize sample agitation

associated with degassing, aeration, and turbidity and to the extent possible, avoid hitting the sides of the well. A tripod and pulley may be used to remove the bailer.

Pouring water from the top of a bailer either directly into a container or to a transfer vessel may agitate/aerate the sample and alter its chemistry; therefore, the pouring should be done with care.

Syringe Samplers

Syringe samplers may be used for low-volume sampling for inorganics and non-volatile organics. These samplers can operate at great depths to provide discrete samples from specific intervals or zones. A sample container is pressured or evacuated and lowered into a well. The sample is collected by opening the container or releasing the pressure, drawing water into the sampler (Nielsen and Nielsen, 2006). The syringe sampler is withdrawn and the sample is transferred to a collection bottle, or alternatively, the syringe sampler can be utilized as the sample container.

Syringe devices cannot be used for purging large volumes and are ineffective for collecting large samples. In addition, ground water containing high concentrations of suspended solids may cause the syringe device to leak (U.S. EPA, 1992). Researchers have concluded that these samplers are inferior in comparison to other devices when sampling for VOCs (Imbrigiotta et al., 1988). Therefore, syringe samplers are not recommended.

Bladder Pumps

A bladder pump consists of a flexible bladder inside a rigid housing. Water enters the bladder from the bottom and is squeezed to the surface through a discharge line by gas pressure applied to the outside of the bladder. An air compressor and regulator turn the pressure on and off, allowing new water to enter the bladder and the cycle is repeated. The separate bladder chamber does not allow the sample to come in contact with the compressed air. Check valves at the top and bottom prevent backwash from the sample tube and bladder. Flow can be readily controlled and low rates of 100 ml/min are easily obtainable. Teflon bladders and Teflon/stainless steel outer shells are readily available and recommended.

Bladder pumps have been used to depths greater than 200 feet and are available in sizes designed for 2-inch wells. The need for a power source and compressed air limits mobility, especially in remote areas. Potential problems include sediment damaging the inner bladder and high suspended solids concentrations causing failure of check valves for some models (Nielsen and Nielsen 2006). Strainers or screens are available that attach below the bladder to filter material. Note that samples collected through a strainer or screens are not considered to be filtered.

Bladder pumps are generally recognized as the best overall sampling device for both inorganic and organic constituents (U.S. EPA, 1992). Muska et al., (1986) found that bladder pumps generate reproducible analytical results. Kasper and Serkowski (1988) concluded that the sampling rate and reliability of the bladder pump outperformed both the gas and mechanically driven piston pumps. Tai et al. (1991) concluded that a bladder pump yielded

representative recoveries of VOCs compared to a control sample. Pohlmann and Hess (1988) determined that bladder pumps are suitable for collecting samples for almost any constituent.

Bladder pumps are recommended for purging and sampling. Whenever possible, the pump should be dedicated to the well. Doing so eliminates the need to transport and decontaminate the pump, thereby reducing the potential for cross contamination as well as saving time and reducing project cost.

Electrical Submersible Pumps

A variety of electrical submersible pumps are available. In the past, electrical submersible pumps were primarily designed for use in water supply wells and could not be used for contaminant monitoring purposes. However, manufacturers have since designed low-flow electrical submersible pumps for 2-inch diameter monitoring wells that are capable of collecting representative samples. Submersible pumps designed for ground water sampling incorporate non-sorptive materials (e.g., stainless steel, Teflon®, etc.) that are appropriate for collecting VOCs and other sensitive parameters. One disadvantage is that the heat generated by the motor could increase sample temperature, resulting in the loss of dissolved gases and VOCs and subsequent precipitation of trace metals (Nielsen and Nielsen, 2006). Therefore, after sampling, it is recommended that a sample be withdrawn and the temperature measured to assess whether the pump has increased the water temperature. Another disadvantage is the number of intricate parts, which may cause decontamination and maintenance to be time-consuming and difficult.

Two types of submersible pumps available are the centrifugal and the progressive cavity (helical-rotor) pumps. Both are positive displacement devices.

Centrifugal Submersible Pump

Centrifugal submersible pumps designed for 2-inch monitoring wells are usually cooled and lubricated with water rather than hydrocarbon-based coolants and lubricants that could contaminate samples. The electric motor spins or rotates an impeller (or series of impellers) that causes water to be accelerated outward and then upward into and through the pump's discharge lines. The higher the pumping rate, the greater the potential for sample alteration by agitation, increased turbulence, and pressure changes. Therefore, a variable-speed centrifugal submersible pump capable of low-flow purging and sampling is essential for collecting a representative sample. Low-flow centrifugal submersible pumps appear to perform similarly to low-flow bladder pumps with respect to preserving sample integrity.

Progressive Cavity (Helical-Rotor) Pumps

Progressive cavity (helical-rotor) pumps are appropriate for collecting sensitive samples if low-flow pumping rates are used. An electric motor at the base turns a corkscrew-like helical rotor near the top. The helical rotor causes an upward movement of water trapped in the vacuities of the rotor and the water moves up and through the discharge line. A check valve at the top ensures that water in the discharge line (sampling tube) does not re-enter the pump. A controller box at the surface allows for variable flow rates.

Gas-Driven Piston Pumps

Although not commonly used, the gas-driven piston pump is acceptable as long as the parts contacting samples are chemically inert (i.e., will not affect sample representativeness). This device utilizes gas pressure to drive a piston between two chambers, one for gas and one for water. Gas is injected through one of two tubes to lower the piston in the gas chamber, allowing water to fill the upper water chamber. Pressure is then applied to a separate tube that pushes the piston upward and propels the sample to the surface. Water and gas remain separated. These pumps can operate at great depths and collect large-volume samples. Disadvantages are that valves and pistons are known to be damaged by fine-grained sediments and mobility is limited by the need for a gas supply. Additionally, the valving mechanism may cause a series of pressure drops that could cause sample degassing and pH changes (U.S. EPA, 1992).

Suction Lift Pumps

Suction lift pumps deliver samples by applying a vacuum at the surface. The negative pressure is applied by a portable pump attached to a tube lowered into the well. Suction pumps are limited by practical suction limits, which restricts their use to wells with water levels less than 25 feet below ground.

Surface centrifugal and **peristaltic** are the two major types of suction lift pumps. The peristaltic offers greater advantages over the surface centrifugal. Surface centrifugal pumps must be primed before being operated, and should employ a vacuum flask to prevent contact of the sample with moving parts. Peristaltic pumps are self-priming and create a vacuum by a series of rotating wheels that compress the sample tubing. As the sample only contacts the tubing when using a peristaltic pump, no moving parts need to be decontaminated. Usually, disposable tubing is used. Peristaltic pumps generally cause less agitation than surface centrifugal pumps.

Suction lift pumps are very portable, widely available, and relatively inexpensive. Flow rates are controlled easily, providing adequate rates for sampling. These devices typically can be used in wells of any diameter and plumbness. The major drawback is that the application of strong negative pressures promotes degassing; therefore, these devices are not recommended for collecting samples to be analyzed for volatile, semi-volatile, pH, Eh, dissolved metals, dissolved gasses, and other gas-sensitive parameters. The National Council of Industry for Air and Stream Improvement (NCASI, 1984) found a 10 to 30 percent loss in VOC concentrations from peristaltic/vacuum flask systems compared to results for bailers, bladder pumps, or submersible pumps. Imbrigiotta et al. (1988) also attributed losses of VOCs due to the vacuum created by peristaltic pumps.

Passive Diffusion Samplers

Passive diffusion bag samplers (PDBs) use a low-density polyethylene diffusion membrane filled with deionized water to collect water samples for VOC analysis. The polyethylene acts as a semi-permeable membrane allowing volatile contaminants to diffuse into the deionized water. Once chemical equilibrium is reached, a water sample that is representative of the VOC concentrations may be obtained for the interval at which the sampler is placed. Use of

multiple PDB samplers at different depths within a well screen interval can allow for a vertical profile of the VOC contamination within the well. Advantages of PDB sampling include its low cost, minimal purging and water disposal, and the ability to monitor a variety of VOCs. A disadvantage is that they are not applicable to inorganics and other contaminants that do not readily diffuse across the semi-permeable membrane. PDB sampling may not be applicable for sites where water in the well casing may not be representative of the saturated zone adjacent to the well screen. This may occur when water in the well casing is stagnant, or when there is a vertical flow within the well. In addition, PDB samplers do not provide a discrete time-interval sample, but rather an average of the concentrations in the well over the equilibrium period.

Passive diffusion bag samplers are appropriate for long-term monitoring at well-characterized sites. The target analytes should be limited to chemicals that have been demonstrated to diffuse well through polyethylene (i.e., most VOCs and limited non-VOCs), as listed in Tables 1-1 and 4-1 of ITRC's PDB sampler guidance document (ITRC, 2004). A combined version of these tables is provided below as a reference (Table 10.2). However, as the compound list may change as further tests are conducted, ITRC (<http://www.itrcweb.org>) should be contacted for the most recent list of chemicals favorable for sampling with PDB. The site sampled should have sufficient ground water flow to provide equilibrium between the water in the well screen and the surrounding ground water zone. ITRC (2004) suggests that care should be given in interpreting PDB results when the hydraulic conductivity is $<10^{-5}$ cm/s, the hydraulic gradient is <0.001 , or the ground water velocity is <0.5 ft/day. Use of PDBs is not appropriate when a vertical flow in the well exists. A deployment time of at least two weeks is recommended to allow for diffusion of the analytes across the membrane (ITRC, 2004, Vrobesky, 2001; Vrobesky and Hyde, 1997; Yeskis and Zavala, 2001; and U.S.G.S , 2002).

Other Devices

The **gas drive sampler** operates by applying positive gas pressure into a sample chamber to force the water to the ground surface. Water enters through a valve at the bottom of the sampler into the sample chamber. When pressure is applied, the valve closes and water is forced through a discharge line to the surface. When the pressure is reduced, the valve reopens, allowing water to enter the chamber, and the cycle is repeated.

Gas drive samplers are available with inert components and in a variety of diameters. They can provide continuous flow at acceptable rates for sampling. Their major drawback is that they allow for gas contact with the sample, which can cause the loss of dissolved gasses and VOCs and potentially other chemical alterations. Gas can also mix with the sample, causing further alteration. For these reasons, use of these samplers is generally not recommended. Additionally, mobility is limited by the need to provide compressed gas. When sampling very deep wells, high gas pressures are needed, and the device should be designed to handle this added stress.

Gas lift samplers inject air or gas into the water column to "blow" water to the surface. The gas acts as a carrier fluid; however, the gas (even if inert) causes degassing and volatilization. Additionally, aeration and turbulence can further alter the original water chemistry (Lee and Jones, 1983). Therefore, gas lift systems are unacceptable.

Table 10.2 Compounds tested with PDB in laboratory and field tests.

Favorable laboratory diffusion testing results		
Benzene	1,3-Dichlorobenzene	Napthalene*
Bromodichloromethane*	1,4-Dichlorobenzene	1,1,2,2-Tetrachloroethane
Bromobenzene**	Dichlorodifluoromethane	Tetrachloroethene (PCE)
Bromochloromethane**	1,1-Dichloroethane**	Toluene
Bromoform*	1,2-Dichloroethane	1,2,3-Trichlorobenzene**
<i>n</i> -Butylbenzene**	1,1-Dichloroethene	1,2,4-Trichlorobenzene**
<i>sec</i> -Butylbenzene**	<i>cis</i> -1,2-Dichloroethene	1,1,1-Trichloroethane
<i>tert</i> -Butylbenzene**	<i>trans</i> -1,2-Dichloroethene	1,1,2-Trichloroethane
Carbon disulfide**	1,2-Dichloropropane	Trichloroethene (TCE)
Carbon tetrachloride	<i>cis</i> -Dichloropropene*	Trichlorofluoromethane
Chlorobenzene	1,2-Dibromoethane*	1,1,2-Trichloro-1,2,2-trifluoroethane**
Chloroethane	<i>trans</i> -1,3-Dichloropropene*	1,2,3-Trichloropropane*
Chloroform*	Ethyl benzene	Vinyl chloride
Chloromethane	Hexachlorobutadiene**	<i>m,p</i> -Xylene**
2-Chlorovinylether*	<i>p</i> -Isopropyltoluene**	<i>o</i> -Xylene**
Dibromochloromethane	1-Methylethylbenzene**	Xylenes (total)
Dibromomethane		
1,2-Dichlorobenzene		
Unfavorable diffusion testing results		
Acetone*	Methyl <i>tert</i> -butyl ether*	Styrene*
<i>tert</i> -Amyl methyl ether**#	Napthalene**	1,2,4-Trimethylbenzene**
Bromoform**#	<i>n</i> -Propylbenzene**	1,3,5-Trimethylbenzene**
Methyl <i>iso</i> -butyl ketone*		

* Laboratory results only, (Vrobesky 2001a)

**Results from field tests only, (Parsons 2003)

#The data set for this compound was relatively small (fewer than five instances of comparison), so the power of the classification (i.e., acceptable or unacceptable) is fairly low.

Use of Packers

Packers are inflatable rubber devices used in a well or open borehole to isolate water-bearing intervals for hydraulic testing or ground water sampling. Packers can be used to minimize purge volumes in wells with long intake columns by isolating the sampled zone from stagnant water above the screen. Both single and double packer assemblies are used. For sampling, a pump is typically installed above or below a single packer or within a double packer assembly with a discharge line extending through the upper packer. Packer assemblies may include a drop tube through which water level tapes, transducers, pump control and discharge lines, and other monitoring and sampling equipment may extend to the isolated interval.

Prior to using packer assemblies for sampling, all potential limitations or problems should be carefully evaluated and resolved, and the use of packers should be justified. For example, packer materials selected should not leach or sorb contaminants. In addition, the water level within the packer interval should not be drawn down below the upper packer. The potential for vertical movement of ground water to or from the packer interval outside of the well or borehole should be evaluated, as well as the potential for leakage around the inflated packers. For additional discussion on packers, refer to Oliveros et al.(1988).

Table 10.3 Summary of recommendations for sampling mechanisms⁵.

MECHANISM	RECOMMENDATIONS	POTENTIAL FOR CHEMICAL ALTERNATION^z	COMMENTS
Bailer	Double check valve bailers with bottom emptying device Can be used for sampling organics and inorganics.	slight to moderate	Samples may show statistically lower analytical results. Other techniques <i>may</i> be more appropriate when low levels of organics exist.
Bladder pump	Highly recommended. Can be used for sampling organics and inorganics	minimum to slight	Provides efficient well purging and representative samples over a range of conditions.
Electric Submersible Pumps	Pumps should be constructed of inert components and capable of sampling at low flow rates. Can be used to sample organics and inorganics.	slight to moderate	Good for purging and sampling deep, high yielding wells. Recommend monitoring temperature, to assure pumping does not increase sample temperature.
Gas Driven Piston Pumps	Acceptable if sample compositions are met. Can be used to sample organics and inorganics.	slight to moderate	Difficult to decontaminate.
Syringe Sampler	Recommended for low volume sampling of discrete zones. Can be used for sampling inorganics and non-volatile organics, not recommended when sampling for volatiles.	minimum to slight	Cannot be used for purging.
Suction Lift Pumps (Peristaltic/ Centrifugal)	Not recommended for sampling for volatiles and semi-volatiles	moderate to high	Can cause significantly lower recoveries of purgeable organic compounds and gases.
Passive Diffusion Bag Samplers (PDB samplers)	Long-term monitoring of VOCs at sites with sufficient ground water flow. Cannot be used for inorganics or most non-VOCs	slight	Sampler does not provide a discrete time-interval sample, but instead an average concentration over the equilibration period Not appropriate if chemicals of concern are transported on suspended particles Not acceptable for inorganics or phthalates.

⁵Table does not address gas drive and gas lift samplers. These devices generally are not recommended.

FIELD PROCEDURES

As appropriate, the health and safety plan should be reviewed prior to initiating field procedures. Sampling personnel should not use perfume, hand lotion etc. when collecting a ground water sample. If insect repellent is necessary, then care should be taken not to allow the repellent to come into contact with the sampling equipment and it should be recorded that insect repellent was used (Wilson, 1995). Activities that may affect sampling, such as fueling a vehicle, should be avoided.

Prior to sampling, several tasks should be completed and documented to ensure that representative samples can be obtained. These tasks include, but are not limited to: observation of field conditions, well inspection and preparation, well measurements, and immiscible layer detection. (Documentation guidance is provided in subsequent parts of this chapter).

FIELD CONDITIONS

Weather and site-specific conditions that could affect sample representativeness should be documented. The approximate ambient air temperature, precipitation, and wind and other field conditions should be noted in a field notebook or field sampling form. In addition, any site-specific conditions or situations that could potentially alter the ground water samples or water level measurements should be recorded. Examples include, but should not be limited to: excavation or construction activities, accidental spills, and presence of smoke, vapors, or air contaminants from anthropogenic activities.

WELL INSPECTION AND PREPARATION

Upon arrival, the well protective casing, cap, and lock should be carefully inspected and observations recorded to document whether damage or tampering has occurred.⁶ Cracks in the casing and/or surface cement seal should be noted, as well as soil washouts and depressions around the casing.

Before taking any measurements, all weeds and debris should be cleaned from the well area. All equipment should be covered and stored off the ground to avoid potential cross-contamination. A clean plastic sheet can be placed on the ground to help prevent contamination of equipment if there is a concern that sample equipment may come into contact with the ground. The plastic should be disposed properly following completion of sampling at each well. A portable field table covered with a new plastic sheet at each well is convenient for preparing equipment and performing field measurements (Wilson, 1995).

⁶ See Chapter 8 (Well Development, Maintenance, and Redevelopment) for additional information on periodic well maintenance checks and well-integrity tests).

WELL MEASUREMENTS

Appropriate measurements should be made before any water is purged and sampled. These include measuring of static water levels and total well depth, and depending on site-specific conditions or circumstances, detection of gases, organic vapors and immiscible liquids.

Detection of Organic Vapors and Gases

Because VOCs often present health and safety concerns, it may be prudent to use field screening instruments if VOCs are suspected. Two field screening instruments that may be useful are the photoionization detector (PID) and an organic vapor analyzer (OVA).⁷ PIDs and OVAs are typically used to provide an estimate of the total volatile organic vapor concentration (e.g., benzene, vinyl chloride, tetrachloroethane), rather than a quantitative result for individual compounds. OVAs are capable of detecting methane, while PIDs are not. The selection of the correct lamp is important when using a PID meter. Field meters are available for detecting methane, carbon dioxide, and hydrogen sulfide, including combination meters that can be used to screen for two or more of these gases. Vapor measurements can give useful information about potential ground water quality and allow for sampling personnel to take appropriate safety precautions. It also may be useful to determine the potential for the presence of immiscible layers, which necessitate additional sampling procedures and concerns.

Gases that typically may be of concern include methane, carbon dioxide, and hydrogen sulfide. Generally, methane and carbon dioxide may occur in monitoring wells at solid waste landfill facilities. Methane may also be present as natural gas in bedrock formations. The presence of methane is significant because it may include trace amounts of VOCs that are too low to be detected with a PID or OVA. Additionally, methane is a health and safety concern because it can cause a potentially explosive atmosphere. Carbon dioxide may affect ground water chemistry by altering pH or alkalinity. Hydrogen sulfide, which is typically associated with sewage or decaying vegetation, may affect pH meter performance. Hydrogen sulfide gas can also be naturally occurring in carbonate bedrock aquifers.

Water Level

In addition to providing hydrogeologic information on a continuing basis, measurement of the water level in a well enables determination of the volume of water contained, which may be useful for purging determinations. Measurements should be taken from the entire well network before any water removal to obtain a single "snapshot" of current hydraulic head conditions and to avoid potential effects on the water levels in nearby wells. The measurements should be made within a period of time short enough to avoid temporal variations in ground water flow that could preclude an accurate determination of ground water flow rate and direction. The period of time should not exceed 24 hours.

Measurements can be taken manually or automatically. Table 10.4 summarizes the manual methods. Automatic, continuous recording devices may be useful for collection of long-term

⁷For further information on types and uses of these instruments, see Anastas and Belknap (1980), Brown et al. (1980) and DuBose et al. (1981).

data and in pumping tests. Water level measurements are described in more detail by Dalton et al. (1991), Aller et al. (1991), and ASTM Method D4750-87. An electronic probe is recommended for taking water level measurements.

Measurements should generally be to within ± 0.01 ft. There may be instances where this level of accuracy is not necessary (e.g., steep water table, wells are far apart); however, rules may require this level of accuracy. All wells should have accurate surveyed reference points⁸ for water level determination. Typically, a marked point on the top of the inner riser pipe is used.

Equipment should be properly decontaminated before use in each well to ensure sample integrity and prevent cross-contamination. Techniques are discussed later in this chapter.

Light non-aqueous phase liquid (LNAPL) (see below) may affect the water level measurements in a well. It is important to know the density of the free product because water level measurements in monitoring wells that also contain free product should be corrected to account for the different densities of water and product and the thickness of the product layer. See U.S. EPA (1996a) for procedure to correct for an LNAPL layer.

Well Depth

Measuring the depth of a well indicates the amount of siltation that has occurred. Natural siltation can block water from entering, which could lead to erroneous water level measurements and bias analytical results by increasing sample turbidity. Checking depth also provides a check on casing integrity. Corrosion can cause collapse of the well casing.

Depth can be determined with a weighted tape measure or marked cable, each of which should be composed of inert materials. Often, the same device that is used to measure water levels can be used. Heavier weights are necessary as depth increases to effectively "feel" the well bottom. The measurement should be recorded on the field log.

It generally is not necessary to measure depth every time water levels or samples are obtained. It may not be possible to obtain depth from a well with a dedicated pump unless the pump is removed. In addition, the logistics of decontaminating the entire length of the measuring tape in contact with contaminated ground water may cause depth measurements to be impractical. At minimum, depth measurements should be taken once a year in wells that do not have dedicated pumps. Measurements in wells with pumps should be taken whenever the pump is removed for maintenance. If siltation is suspected to be a problem (e.g., noted increase in sample turbidity, or decrease in pump efficiency), the pump should be removed and the well depth checked.

⁸It is recommended, the reference point be based on the National Geodetic Vertical Datum or local common datum. However, an arbitrary datum common to all wells in the monitoring network may be acceptable if necessary.

Table 10.4 Summary of methods for manual measurement of water levels (based on Dalton et al., 2006, ASTM D4750 and U.S.EPA, 2001).

MEASUREMENT METHOD	MEASUREMENT ACCURACY (in feet)	DESCRIPTION & ADVANTAGES	MAJOR INTERFERENCES OR DISADVANTAGES
NON-FLOWING WELLS			
Weighted steel tape with chalk	0.01	<p>The water level is determined by lowering a weighted steel tape with bottom 2-3 feet coated with carpenters chalk into the well. The water level is calculated by subtracting the submerged distance, as indicated by the lack of chalk color, from the reference point at the top of the well.</p> <p>More accurate than other methods. Recommended when gradient is less than 0.05 ft/ft (Yeskis and Zavala, 2002).</p>	<ul style="list-style-type: none"> • Water on the side of the casing or cascading water may wet the tape above the actual water level and result in measurement error. • Addition of foreign material to well (chalk). • Approximate depth to water may be unknown, thus too short or too long a length of chalked tape may be lowered into the well. • Submergence of a weight and tape may temporarily cause a rise of liquid in a small diameter well. • Not recommended if obtaining ground water samples for water quality purposes
Air-line	0.25	A small straight tube (usually #0.375 inches in diameter), of accurately known length is installed in the well along with a pressure gauge and a fitting for an air source. A water level measurement is made when air is pumped into the tube and the pressure monitored.	<ul style="list-style-type: none"> • Less precise • Air-line or fittings can leak
Electrical method	0.01 to 0.1	An electronic probe is lowered into the well. When the probe comes into contact with water, a potential between the two dissimilar metals in the probe is measured at the surface on a millivolt meter.	<ul style="list-style-type: none"> • Errors result from changes in cable length as a function of use, temperature and depth • Reliable contact may be difficult if LNAPLs are present

MEASUREMENT METHOD	MEASUREMENT ACCURACY (in feet)	DESCRIPTION & ADVANTAGES	MAJOR INTERFERENCES OR DISADVANTAGES
Transducer	0.01 to 0.1	A transducer is lowered a known distance into the well and allowed to equilibrate with fluid temperature. Distance of submergence of the transducer is read on the signal conditioning unit and is subtracted from the cable length referenced at the top of the well.	<ul style="list-style-type: none"> Accuracy is dependent upon range and sensitivity of the device.
Float	0.02 to 0.5	A float is attached to the end of a steel tape and suspended over a pulley and lowered into the well. A counter weight is attached to the opposite end. Depth to water is read directly from the steel tape at a known reference point from top of casing.	<ul style="list-style-type: none"> Error can be caused by float or cable drag, line shift, submergence of counter-weight, and temperature and humidity.
Popper	0.1	A metal cylinder with a concave bottom is attached to steel tape and lowered into the well. A distinct "pop" can be heard when the cylinder is dropped onto the water surface	<ul style="list-style-type: none"> Accuracy is dependent upon skill of measurer and depth to water. Potential to agitate water. Contact cannot be made reliably when LNAPLs are on the water surface.
Acoustic Probe	0.02	Adaptation of the popper and electrical method [Schrale and Brandywyk (1979)]. An electric device is lowered into the well until an audible sound is emitted.	<ul style="list-style-type: none"> Cascading water can cause false measurements. Contact cannot be made reliably when LNAPLs are on the water surface.
Ultrasonic	0.02 to 0.1	Water level measurements are determined by an instrument that measures the arrival time of a reflected transmitted sonic or ultrasonic wave pulse.	<ul style="list-style-type: none"> Accuracy can be limited by the change of temperature in the path of the sound wave and other reflective surfaces in the well (i.e., casing, pumps, etc.). Greater depth, the less accurate.
Radar	0.02	Unit provides a pulsed or continuous high frequency wave that reflects of the water surface in the well.	<ul style="list-style-type: none"> Requires a plumb well, obstacles can prevent a clean line of site down the well. Generally limited to larger wells and water levels less than 100 feet.

MEASUREMENT METHOD	MEASUREMENT ACCURACY (in feet)	DESCRIPTION & ADVANTAGES	MAJOR INTERFERENCES OR DISADVANTAGES
Laser	0.01	Battery operated units potentially capable of obtaining water level information from monitoring wells.	<ul style="list-style-type: none"> • Further development is needed for adopting it to ground water monitoring programs • Requires a plumb well, obstacles can prevent a clean line of site down the well. • Beams can sometimes penetrate the water and not reflect back
FLOWING WELLS			
Casing Extension	0.1	A simple extension is attached to the well casing to allow water level to be measured directly.	<ul style="list-style-type: none"> • The device is only practical when additional height requirement is only several feet. • Accuracy low because water level in flowing wells tends to fluctuate.
Manometer/ Pressure Gauge	0.1 to 0.5	The pressure of water within a sealed or "shut-in" well is measured.	<ul style="list-style-type: none"> • Gauge inaccuracies. • Calibration is required.
Pressure Transducers	0.02	Procedures are the same as described above for transducers. The range of a pressure transducer should be carefully matched with shut-in well pressure.	<ul style="list-style-type: none"> • Changes in temperature in the transducers cause errors.

Depth measurements should be to the nearest 0.1 foot (U.S. EPA, 2001). Depth to bottom can be obtained when collecting the round of depth-to-water measurements. Care should be taken to avoid stirring up any accumulated sediments, thus increasing turbidity of the water column. If a well has historically had silting problems, consider taking the depth measurement after sampling.

Detection of Immiscible Liquids

Non-aqueous phase liquids (NAPLs) are organic liquids that exist as a separate phase, immiscible phase when in contact with water and/or air. If the presence of NAPLs is suspected, the sampling program should include devices and protocols to detect them. Dense non-aqueous phase liquids (DNAPL) are referred to as "sinkers" because their density (greater than water) causes them to sink. Light non-aqueous phase liquids (LNAPL) are referred to as "floaters" because their density (less than water) causes them to float on the water table surface. If floaters are of concern, it is important that, upon opening the well cap, the air in the casing is monitored with a photoionization detector (PID) or an organic vapor analyzer (OVA). In addition to providing information on worker health risks, air monitoring can serve as a first indication of the presence of volatile floaters.

Protocol to detect immiscible liquids should always include visual inspection of purged water and any equipment that is removed from the well after use. Additionally, probes and reactive pastes have been developed to determine air/immiscible and water/immiscible interfaces. Indicator pastes are used to coat an interface probe or a weighted tape. An observed reaction indicates the presence of an immiscible liquid. Probes and pastes can be utilized for detecting both floaters and sinkers (U.S. EPA, 1992). Transparent bailers also can be used.

SAMPLING IMMISCIBLE LIQUIDS

If an LNAPL is found to be present, a bailer or submersible pump can be used to remove it, if necessary (U.S. EPA, 1992). Any LNAPL greater than 2 feet in thickness can be evacuated using a bottom-valved bailer. The bailer should be lowered slowly to a depth less than the product/water interface. A modified, top-filling bailer (bottom valve sealed off with a fluorocarbon resin sheet between the ball and ball seat) can be used to remove immiscible layers less than 2 feet in thickness. A stainless steel weight can be added to the retrieval line above the bailer to counter its buoyancy. In either case, a peristaltic pump also can be utilized if depth to product is less than 25 feet. Any LNAPL less than 2 inches thick can be collected from the top of the water column using a bailer (U.S. EPA, 1992). Samples collected in this manner consist of both an aqueous and non-aqueous phase.

To the extent possible, the sampling and purging method should prevent the disturbance of DNAPL. A sample of the DNAPL should be obtained after the ground water sample has been obtained. Double-check valve bailers, Kemmerer devices and syringe samplers often are used. Submersible pumps can be used if the dense phase is sufficiently thick (U.S. EPA, 1992).

When an immiscible layer is to be analyzed, additional sampling equipment (i.e., containers) may be needed to have sufficient volume for laboratory analysis. It is important that appropriate QA/QC procedures be followed when collecting samples of any immiscible liquids. If any immiscible layer is removed, it should be properly collected, containerized, characterized, and managed. The Division of Hazardous Waste Management, Ohio EPA, can be contacted for guidance on these issues.

SAMPLING AND PURGING PROCEDURES

Upon completion of the preliminary procedures, purging and sampling of ground water can generally be accomplished by volumetric or low flow rate methods. However, volumetric purging and low flow rate purging/sampling may not be feasible for wells that produce less than 100 ml/min. Therefore other approaches should be considered, including minimum/no purge sampling as well as purging to dryness and sampling as soon as the well has recharged sufficiently. These approaches are discussed below, along with methods to determine when purging is complete by measuring indicator parameters. Where dedicated equipment is not used, sampling should progress from wells least likely to be contaminated to those most likely to be contaminated to minimize the potential for cross-contamination. Care needs to be taken to avoid agitation and temperature increases in the sample during sample collection and shipment to the laboratory.

Field Measurements of Ground Water Indicator Parameters

Indicator parameters are measured in the field to evaluate well stabilization during purging, provide information on general ground water quality, help evaluate well construction, or indicate when well maintenance is needed. Indicator parameter data may be helpful in evaluating the presence of ground water contamination. Indicator parameters measured during well purging and sampling activities may include specific conductance, pH, dissolved oxygen, oxidation-reduction potential, temperature, and turbidity (Garner, 1988). Due to the unstable nature of these parameters, laboratory determinations will likely not be representative of field conditions, and consequently are of limited value.

Specific conductance measures the ability of water to conduct an electric current. For ground water, it is generally reported in micromhos ($\mu\text{mhos/cm}$), as natural waters commonly exhibit specific conductances well below 1 $\mu\text{mhos/cm}$ (Hem, 1992). Specific conductance is a relative measure of the amount of ions present in ground water, as the magnitude of the current conducted by a ground water sample is directly proportional to its ionic concentration. Based on this relationship, total dissolved solid concentrations may be approximated from specific conductance data (Hem, 1992). For most circumstances, specific conductance has been demonstrated to be a reliable indicator of the chemical stabilization of purge water (e.g., Barcelona et. al., 1994).⁹ High readings may indicate contamination, especially if the readings are elevated compared to background. Alternatively, elevated specific conductance may indicate grout contamination in a well or an inadequate grout seal, that is allowing infiltration of surface water or ground water from overlying saturated zones. Elevated specific conductance readings may also indicate inadequate well development (Garner, 1988).

pH is a measure of the effective concentration (or activity) of hydrogen ions and is expressed as the negative base-10 logarithm of the hydrogen-ion activity in moles per liter. Uncontaminated ground water typically exhibits a pH ranging from 5 to 9 (Brownlow, 1979;

⁹Specific conductance should not be used by itself to determine whether adequate purging has been completed. Ohio EPA recommends using multiple indicator parameters to determine when to terminate purging and begin sampling regardless of the assumed reliability of the data.

Ohio EPA, 2003). While pH has commonly been used as a purge water stabilization indicator, it is not particularly sensitive in distinguishing stagnant casing water from formation water. However, pH measurements are important for the interpretation of ground water quality data (Puls and Barcelona, 1996), as pH indicates the relative solubility of metals and speciation of many other chemicals (Garner, 1988). First, pH measurements reflect chemical reactions that produce or consume hydrogen ions (Hem, 1992), and therefore, changes in pH from background may indicate the presence of ground water contamination or that existing contamination has spread. Second, pH can be very useful in identifying well construction or maintenance problems. For example, pH readings that consistently increase in (7.8, 8.3, 8.8, 9.4...) during purging may indicate grout contamination in the sand pack and screened interval.

Dissolved oxygen (DO) has been demonstrated to be a reliable indicator of the chemical stabilization of purge water under most ground water purging and sampling circumstances (e.g., Barcelona et. al., 1994).¹ DO is a good indicator when sampling for volatile organic compounds (VOCs), because erratic or elevated DO readings may reflect procedures that are causing excessive agitation and aeration of the ground water being drawn from the well and subsequent loss of VOCs (Pennino, 1988). Artificially aerated ground water may also adversely affect dissolved metals analyses. Concentrations of DO in ground water (1 to 4 mg/l, Testa and Winegardner, 1991) tend to be lower than surface water concentrations (7 to 14 mg/l, Deutsch, 1997), but are generally measurable using field probes, even in deep aquifers (Hem, 1992; Rose and Long, 1988). Atmospheric oxygen is the principal electron sink for redox processes in the hydrosphere (Hem, 1992), and DO in ground water is depleted by reactions involving both inorganic and organic constituents. Accordingly, relatively low DO concentrations (< 1 mg/l) in ground water may indicate the biodegradation of organic contaminants, including VOCs (U.S. EPA, 1997). For example, low DO concentration may indicate the presence of petroleum products, industrial solvents, or a solid waste leachate plume.

Oxidation-reduction potential (ORP), also referred to as redox potential or Eh, is a numerical index of the intensity of the oxidizing or reducing conditions within an aqueous solution such as ground water. Oxidizing conditions are indicated by positive potentials and reducing conditions are indicated by negative potentials. ORP measurements are generally expressed in millivolts (mV). The ORP of natural (uncontaminated) ground water typically ranges from +500 to -100 mV (Brownlow, 1979). Ground water contaminated with organic compounds generally exhibits depressed ORP values compared to background conditions and may exhibit ORP values as low as -400 mV (Wiedemeier et. al., 1997). ORP may not be an appropriate stabilization parameter for some ground water conditions (Yeskis and Zavala, 2002). ORP data is useful for evaluating the expected oxidation state of dissolved metals and other chemical species in a general sense, especially when collected with pH data. Such information may be helpful for fate-and-transport modeling. However, aquifers and other saturated zones are open systems that are effected by many variables, and therefore, the actual chemical species present in ground water will not necessarily correspond to measured ORP and pH data (Hem, 1992; Rose and Long, 1988). In addition, ORP values cannot be used to derive or infer dissolved oxygen values, and vice versa (Rose and Long, 1988).

Temperature is not necessarily an indicator of ground water chemical stabilization, and is generally not very sensitive in distinguishing between stagnant casing water and formation water (Puls and Barcelona, 1996). Nevertheless, temperature is important for data interpretation. For example, stabilized temperature readings that are representative of typical ground water conditions help demonstrate that the sample was collected in a manner that minimized exposure to elevated temperature variations, e.g., heating from the electric motor of a submersible pump. Elevating the temperature of a sample may result in loss of VOCs or the progression of chemical reactions that may alter the sample quality in an undesirable manner. Ground water temperatures in Ohio typically range from 9 to 13 C (Heath, 1987).

Turbidity, which is the visible presence of suspended mineral and organic particles in a ground water sample, also is not an indicator of ground water chemical stabilization and does not distinguish between stagnant casing water and formation water. However, turbidity can be useful to measure during purging. Relatively high or erratic measurements may indicate inadequate well construction, development or improper sampling procedures, such as purging at an excessive rate that exceeds the well yield (Puls and Powell, 1992; Paul *et. al.*, 1988). Purging and sampling in a manner that produces low-turbidity water is particularly important when analyzing for total metals, which may exhibit artificially elevated concentrations in high-turbidity samples (Gibbons and Sara, 1993). Generally, the turbidity of *in-situ* ground water is very low (Nightingale and Bianchi, 1977). When sampling for contaminants or parameters that may be biased by turbidity, Ohio EPA recommends stabilizing the turbidity readings at or below 10 NTUs (Yeskis and Zavala, 2002). It is recognized that some ground water zones may have natural turbidity higher than 10 NTUs. If turbidity is being used as a stabilization parameter, it may be necessary to evaluate the stabilization criteria on a site-by-site basis. The stabilization criteria would be \leq 10 percent.

Table 10.5 provides stabilization criteria for each parameter discussed above. It is recommended that specific conductance plus two additional parameters be selected. A parameter can be considered stable when at least three consecutive readings have stabilized. The interval between measurements is discussed in the particular purging/sampling methodology section.

Field measurements performed to fulfill regulatory requirements, beyond those used to measure for stabilization, should be obtained after purging and before samples are collected for laboratory analysis. Portable field instruments should be used. Probes enabling down-hole measurement can be used and may increase data representativeness. All in-well instruments and probes should be appropriately decontaminated before use to prevent contamination of the well water. Flow-through cells can be used when sampling with pumps.

Calibration of instruments should occur in the field, as close to the time of use as possible and, at least, be at the frequency suggested by the manufacturer. A pH meter should be periodically calibrated with a two-point calibration by using two buffer solutions that bracket the expected pH range of the ground water. If field measurements fall outside the calibrated range, then the meter may need to be recalibrated with appropriate solutions. Calibration of dissolved oxygen meters should be done at least once a day and possibly more if changes in elevation or atmospheric pressure occur. Checking and documenting the performance of an electronic dissolved oxygen meter against a titration method at least once per day is

recommended. A conductivity meter should be checked with standard solutions prior to going out in the field. If it is out of the prescribed tolerances, it may need servicing prior to use. Checking and documenting the performance of the conductivity meter may be done in the field with two audit solutions. All calibration and recalibration checks should be recorded in a field notebook or on field forms (Wilson, 1995).

Table 10.5. Stabilization Criteria with References for Water-Quality Indicator Parameters (Yeskis and Zavala, 2002).

Parameter	Stabilization Criteria	Reference
pH	± 0.1 standard units*	Puls and Barcelona, 1996 Wilde et al. 1998
specific conductance	± 3%	Puls and Barcelona, 1996
oxidation-reduction potential (ORP)	± 10 millivolts	Puls and Barcelona, 1996
turbidity	± 10% (when > 10 NTUs) maintained at < 10 NTUs, consider stabilized	Puls and Barcelona, 1996 Wilde et al. 1998
dissolved oxygen (DO)	± 0.3 milligrams per liter	Wilde et al. 1998
temperature	± 0.5 ° Celsius	

* The ± 0.1 may not always be obtainable, especially if purging and sampling with bailers. Therefore, professional judgement may be needed.

Volumetric Purging & Sampling

Traditionally, a sample has been collected after purging of a specified volume of water. The various types of sampling and purging equipment, their pros and cons, and recommended uses are described in detail in the section on types of equipment (page 10-10). It is recommended that sampling equipment be dedicated to specific wells to eliminate the need for decontamination. This is most important when pumps are used because their intricate design can often make adequate cleaning difficult.

The amount of water purged is usually three to five well volumes. Some have suggested the number of bore volumes should range from less than 1 to more than 20 (Gibb et. al., 1981).

One well volume can be calculated as follows:

$$V = H \times F$$

where:

V = one well volume.

H = difference between depth of well and depth to water (ft).

F = factor for volume of 1-foot section of casing (gallons).

Table 10.6 provides F for various casing diameters. Multiplying the computed volume (V) times the number of desired volumes to be purged will give the volume of water in gallons to be evacuated.

Table 10.6 Volume of water in one-foot section of well casing.

Diameter (Inches)	F ¹ (Gallons)
1.5	0.09
2	0.16
3	0.37
4	0.65
6	1.47

¹ F is the volume (in gallons) in a 1-foot section of the well and is computed using:

$$F = 3.14 \left(\frac{D}{2} \right)^2 \times 7.48 \frac{\text{gal}}{\text{ft}^3}$$

Where: D=the inside diameter of the well casing (ft).

Field stabilization parameters, as discussed above, should be monitored for stability to determine if additional purging is necessary.

For volumetric purging, it is suggested that stabilization parameters be collected every ½ well/screen volume after an initial 1 to 1½ well volumes are purged (U.S. EPA, 2002). The volume removed between readings can be adjusted as well-specific information is developed. Field meters or flow through cells that allow continuous monitoring of stabilization parameters can be used. When using a flow meter, the capacity of the cell should be such that the flow of water in the cell is replaced between measurements of the stabilization parameters.

Purging should be at or below rates used for development and those observed for well recovery. Excessive rates may result in the introduction of ground water from zones above or below the well screen, which could dilute or increase contaminant concentration in samples. Overpurging also may cause formation water to cascade down the screen, enhance the loss of VOCs, and introduce oxygen into the subsurface, which may alter water geochemistry and affect chemical analysis. As indicated by Puls and Powell (1992), excessive rates may also lead to increased sample turbidity and the exposure of fresh surfaces capable of adsorbing dissolved metals. If bailers are used for purging, entry and withdrawal to and from the water column should be as slow as possible. Water entrance velocities into bailers can correspond to unacceptably high purging rates (Puls and Powell, 1992).

Monitoring wells should be sampled immediately after purging, unless site-specific conditions preclude it (e.g., if some wells are too low-yielding). This minimizes the time for physical and

chemical alteration of water in the well casing. Where immediate resampling is precluded, sample collection should begin no later than 24 hours after purging.

Low-Flow Purging/Sampling

Low-flow purging, also referred to as low-stress purging, low-impact purging, minimal drawdown purging, or Micropurging®, is a method of well purging/sampling that does not require large volumes of water to be withdrawn. The term low-flow refers to the fact that water enters the pump intake with a low velocity. The objective is to minimize drawdown of the water column in the well, avoid disturbance of the stagnant water above the well screen, and draw fresh water through the screen at a rate that minimizes sample disturbance. Usually, this will be a rate less than 500 ml/min and may be as low as 100 ml/min. Once drawdown stabilizes, the sampled water is isolated from the stagnant water in the well casing, thus eliminating the need for its removal (Powell and Puls, 1993).

The method is based on the principle that water within the screened zone passes through continuously and does not mix with water above the screen. After drawdown has stabilized and indicator parameters have stabilized, water in the screen can be considered representative of water in the formation. Given this, purging of multiple well volumes is not necessary (Kearl et al., 1994; Powell and Puls, 1992; Nielsen and Nielsen, 2002, ASTM Method D6771-02). A packer assembly may be necessary in fractured bedrock.

Low-flow sampling offers several advantages. It lessens the volume of water to be purged and disposed, reduces aeration or degassing, maintains the integrity of the filter pack, and minimizes disturbance within the well water column and surrounding materials, thus reducing turbidity. Accordingly, filtering of samples may be avoided, and low-flow sampling may allow for the quantification of the total mobile dissolved phase and the contaminants sorbed to mobile particles. Disadvantages include higher initial setup costs, need for greater setup time in the field, and increased training needs. In addition, this procedure does not address sampling from wells with LNAPL or DNAPL.

When performing low-flow purging and sampling, it is recommended that the pump be set in the center of the well screen interval to help prevent disturbance of any sediments at the bottom of the well. If known, the pump can be placed adjacent to the areas with the highest hydraulic conductivity or highest level of contaminants. The use of dedicated pumps is preferred to minimize disturbance of the water column. If a portable pump is used, the placement of the pump can increase turbidity and displace water into the formation. Therefore, the pump must be placed far enough ahead of the time of sampling so that the effect of the pump installation has completely dissipated. The time between pump placement and sampling may vary from site to site, but may be in excess of 48 hours (Kearl, et al., 1992; Puls and Barcelona, 1996; Nielsen and Nielsen, 2002). Use a submersible pump with an adjustable rate, such as a low-flow centrifugal or bladder pump. The pumping rate should be adjusted to less than 1 L/min; pumping rates as low as 500 mL/min to 100 mL/min may be needed. If using a bladder pump, follow the manufacturer's recommendations for adjusting the emptying/filling cycle to minimize the potential for turbid flow. During subsequent sampling events, try to duplicate as closely as possible the intake depth and the stabilized extraction rate from the previous events.

Because the object during low-flow purging and sampling is to minimize drawdown, it is important to measure the water level in the well before pumping. To begin purging, the pump should be started at the lowest speed setting and then the speed can be slowly increased until water begins discharging. Check the water level and slowly adjust the pump speed until there is little or no drawdown or drawdown has stabilized. The stabilization should be documented. Water level should be monitored frequently during purging; every three to five minutes is recommended. In practical terms, to avoid drawing stagnant water into the pump, the water level should not exceed the distance between the top of the well screen and the pump intake (Nielsen and Nielsen, 2006). The water level should not be allowed to fall to the pump intake level. If the static water level is above the well screen, the water level should not be allowed to fall below the top of the screen. To minimize disturbance, pumping rate adjustments are best made within the first fifteen minutes of purging.

A sample can be considered representative when both drawdown and water quality indicators have stabilized. In general, at least one screen volume will typically need to be purged; however, stabilization can occur before or after one screen volume. Stabilization measurements should begin after drawdown of the water level has stabilized. Indicator parameters (such as pH, temperature, specific conductance, dissolved oxygen, turbidity, and oxidation/reduction potential) should be monitored frequently. The measurements should be with a hand-held meter or a flow-through-cell and be at least three to five minutes apart. When using a flow meter, the capacity of the cell should be such that the flow of water in the cell is replaced between measurements.

An indicator parameter can be considered stable when at least three consecutive readings have stabilized (See Table 10.5). When all parameters have stabilized, the well may be considered purged and sampling may commence. A turbidity level of less than 10 NTUs is desirable. If the recharge rate of the well is less than the lowest achievable pumping rate, and the well is essentially dewatered during purging, a sample should be taken as soon as the water level has recovered sufficiently to collect the sample, even if the parameters have not stabilized.

When conducting low flow sampling at new wells or established wells being sampled for the first time by low flow procedure, it is recommended the purging process be verified by continuing to purge 9 to 15 minutes, then retaking the stabilization parameters. If the parameters remained stable, then the purging procedure can be established for that well based on pump location, rate of purging, and frequency of obtaining the three sets of stabilization parameters. This will help support whether an appropriate amount of water has been purged from the system.

Minimum/No Purge Sampling¹⁰

Minimum/no purge sampling is best suited for wells that have a tendency to go dry when using other purging and sampling techniques. Minimum/no purge sampling should only be conducted when volumetric or low-flow sampling is not feasible (e.g., well yields less than 100 ml/min) and where there is sufficient water to ensure submergence of the pump intake

¹⁰Referred to in some literature as passive sampling.

during purging and sampling (Nielsen, 2002). It is considered less disruptive than well evacuation.

This method obtains the sample from within the well screen above the pump intake and removes the least possible volume of water prior to sample collection, which is generally limited to the volume of the sampling system, i.e., pump and discharge tubing. A sample is collected immediately after this volume is withdrawn, and is presumed to represent formation water. Very low flow rates are used for minimum/no purge sampling, generally 100 mL/min or less. With minimum/no purge sampling, indicator parameters for chemical stabilization are not monitored. However, indicator measurements may still be needed for other purposes (e.g. regulatory requirements, evaluation of general quality of the ground water). Where the volume of water available is limited, a low-volume flow-through cell can be used to measure indicator parameters.

The volume of water available for sampling within the well screen located above the pump intake should be determined before purging and sampling to avoid drawing down stagnant water from the overlying water column into the well screen interval and compromising the sample. Because of the low hydraulic conductivity and flow rates, the yield may not be sufficient to meet the demands of the pump; thus drawdown is unavoidable. Drawdown should be measured during pumping to ensure that the water above the screened interval is not drawn into the pump. The amount of drawdown should be no more than the distance from the top of the screen and the position of the pump intake within the screen, minus a 2-foot safety margin (Figure 10.1) (Nielsen and Nielsen, 2002).

If available water is insufficient to meet the sample volume requirements, it may be necessary to discontinue the sampling once allowable drawdown is reached. Sample collection should proceed when the well has recharged sufficiently to meet the remaining sampling requirements.

Bladder and low-flow submersible pumps are recommended for minimum/no purge sampling. Bailers, inertial lift samplers, and peristaltic pumps should not be used (ASTM D4448-01, Powell and Puls, no date). Pumps should be placed within the well screen, but not too close to the bottom to avoid drawing in any sediments that may have settled, or too close to the top to avoid incorporating stagnant water that is above the well screen. One to two feet above the bottom is generally sufficient. As with low-flow purging and sampling, lowering a pump into the well can increase turbidity and displace water into the formation. Therefore, the pump must be placed far enough ahead of the time of sampling so that the effect of the pump installation has completely dissipated. Though the time between placement and sampling can vary from well to well, it may be in excess of 48 hours (Kearl, et al., 1992; Puls and Barcelona, 1996; Nielsen and Nielsen, 2002).

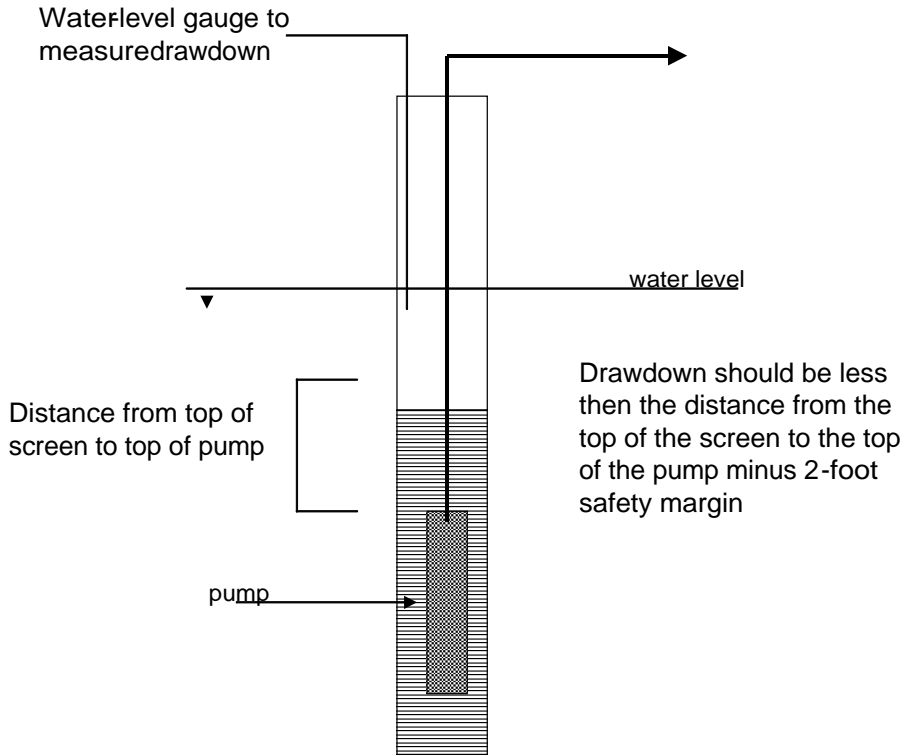

Figure 10.1. Maximum drawdown for minimum/no purge sampling and purging procedure.

Purge to Dryness & Sampling

Traditionally, low-yielding wells have been sampled by purging a well dry and obtaining a sample upon sufficient recovery of the well. However, there are concerns when a well is purged dry, including (Nielsen and Nielsen, 2002; U.S. EPA 2001):

- Cascading water as the well recovers may result in a change of dissolved gases and redox state, thus affecting the concentration of the analytes of interest through oxidation of dissolved metals. In addition, the cascading water can strip volatile organic constituents that may be present;
- Stressing the formation may increase sample turbidity by inducing soil fines into the well or stirring up any sediments that may have accumulated at the bottom of the well;
- Draining the water from the filter pack may result in air being trapped in the pore spaces, with lingering effects on dissolved gas levels and redox states; and
- The time required for sufficient recovery of the well may be excessive, affecting sample chemistry through prolonged exposure to atmospheric conditions.

Attempts should be made to avoid purging to dryness; however, in some situations it may be the only feasible method (e.g., low yielding wells, insufficient water column to use minimum/no purge). If an operating facility monitoring program has been historically

established on purging to dryness, then for consistency, it may be necessary to continue this practice.

If purging to dryness is unavoidable or inadvertent, then samples should be taken as soon as there is a sufficient amount of water. Extended recovery times after purging (hours) allow the ground water to equilibrate with atmospheric conditions. In the case of a well with very slow recharge, sample collection may continue for several days. However, sample collection should be attempted at least every 24 hours. Herzog et al. (1988) concluded that the common practice of next day sampling for low yield, slow recovery wells is adequate. The intervening time should be consistent from event to event. In addition, it is important to evaluate all data from slowly recovering wells based on the possibility that it may be unrepresentative of actual conditions.

Passive Diffusion Sampling

Passive diffusion samplers are a simple and inexpensive way to sample monitoring wells for a variety of VOCs. As described in the previous section (Types of Equipment), the passive diffusion bag is suspended in the well at the target horizon by a weighted line and allowed to equilibrate with the surrounding water (typically 2 weeks). The sampler bags are retrieved from the well after the equilibration period and the enclosed water is immediately transferred to the sample container. Passive diffusion sampling is recommended only for long term ground water monitoring of VOCs at well-characterized sites (ITRC, 2004). PDS is not applicable for inorganics, where there is vertical flow, or when discrete interval samples are needed. See pages 10-15 for more description of the applicability of PDS.

FILTRATION

Ground water samples collected from monitoring wells may contain noticeable amounts of sediment. This sample "turbidity" is an important field concern for samples to be analyzed for metals (e.g., cadmium, nickel, zinc) or metalloids (e.g., arsenic, selenium). If large, immobile particles to which metals are bound are allowed to remain in field-acidified samples, laboratory "total" analyses will overestimate the true concentration of mobile species because acidification dissolves precipitates or causes adsorbed metals to desorb. Additionally, changes in the relative degree of sedimentation over time (due to changes in well performance, sampling device, or sampling personnel) and space (due to natural hydrogeologic variations) can result in data interpretation difficulties.

Removal of sediment by filtration prior to containerization and acidification also presents problems. The potential for filter clogging, variable particle size retention, filter media leaching, and aeration is well documented (Puls and Powell, 1992). Also, filtration has the potential to remove particles that may be mobile in certain hydrogeologic environments. As described by McCarthy and Zachara (1989) and Puls et al. (1990), colloidal material (particles less than 10 micron) may be transported large distances. Because of these difficulties, some investigators (Puls and Barcelona, 1989a & b; Kearl et al., 1992; Puls and Powell, 1992) have recommended against field-filtering. Further, federal regulations [40 CFR 258.53(b)] for ground water monitoring at municipal solid waste landfills specify that analyses for metals be performed on unfiltered samples.

For sampling at sites that are not municipal solid waste landfills, filtration may be appropriate in some instances, provided it is done properly. Significant turbidity is sometimes unavoidable, and filtration may be necessary to remove immobile particles. For example, reducing turbidity may be difficult when a clay-rich glacial deposit is monitored. Clay and natural organic matter can attract contaminants and physically retard particle movement. Therefore, particles in ground water may be presumed to be immobile in formations primarily containing natural organic material and clays. Additionally, while unfiltered data generally would be preferred for a risk assessment of the drinking water pathway, filtered data may be used if there is an obvious discrepancy between filtered and unfiltered data or if secondary MCLs are exceeded (U.S. EPA, 1991). In this case, unfiltered samples might be too turbid to represent drinking water. It is recommended that entities work closely with the Agency to define project requirements. The following sections provide Ohio EPA's general recommendations on whether and how to filter.

Deciding When to Filter

Ohio EPA recommends a general framework (Figure 10.2) for making decisions as to whether filtering is appropriate. As the framework indicates, adequate monitoring wells and sampling techniques that minimize disturbance should be confirmed before any decision is made. Filtration generally should occur only when all of the following conditions are present:

- ***The samples have been collected from monitoring wells that are properly designed, installed, and developed.*** Adequate wells are essential to minimizing turbidity and obtaining representative samples. When turbidity is an issue at an existing well, the well should be redeveloped using appropriate well development techniques outlined in Chapter 8 prior to sampling.
- ***The samples have been collected using procedures that minimize disturbance.*** Low-flow purging and sampling procedures are recommended to minimize agitation of the water column and minimize turbidity. Achieve stabilization of indicator parameters prior to sampling to ensure that the sample is representative of natural ground water conditions. Indicator parameters can include temperature, pH, and conductivity.
- ***Turbidity has been demonstrated to stabilize above 10 NTU.*** (See the Sampling and Purging Procedure Section.)
- ***Professional judgement indicates that the formation sampled does not exhibit a high degree of particle mobility, making it reasonable to assume that a portion of the sediment in the samples may be attributable to immobile particles.*** In general, this judgment can be based on the geology of the ground water zone. For example, clays, because the size of the pores, would prevent particle mobility. Examples of formations that do show significant particle mobility include, but are not limited to, karst; bedrock with open, interconnected fracture, and clean, highly porous gravel-to-boulder sized deposits.

Note that one should exercise professional judgement when applying this approach. Deviations may be necessary if the practices would cause undesirable problems in data

interpretation. For example, if a site is underlain by karst bedrock and the historical data for metals has been based on analyses of filtered samples, filtration could be continued to ensure data consistency and comparability. If a single zone is monitored both by wells that are capable of providing samples that meet the turbidity criterion and wells that are not capable of meeting it, it may be prudent to filter all of the samples to ensure spatial consistency and valid statistical comparisons.

Some entities may wish to collect both filtered and unfiltered samples. The advantage of having both types of data is that a comparison can help determine the form in which a chemical exists (e.g., primarily adsorbed to particulate matter or primarily dissolved) (U.S.EPA, 1989)¹¹. The comparative data may help justify which data set is more appropriate.

Recommended Procedure/Equipment When Filtering is Necessary

If filtration is necessary, the following are recommended:

- **Use “in-line” filtering whenever possible.** In-line methods use positive pressure provided by a sampling pump to force the sample through an attached filter. The advantage is that samples remain isolated prior to atmospheric exposure. Stolzenburg and Nichols (1986) compared different filtering methods and found in-line to provide the best results. If bailers are used for sampling, in-line filters cannot be used unless a pressure or vacuum hand pump (i.e., peristaltic) is utilized to force the sample through.
- If it is not possible to filter in-line, “open system” techniques may be used. These techniques require a transfer of the sample before filtration, thus allowing for additional exposure and agitation. Open system filtration should be conducted immediately in the field, at the wellhead, and prior to sample acidification and containerization. If filtration does not occur immediately, metals can begin to precipitate and, upon filtration, be removed, causing laboratories to underestimate actual concentrations. Agitation should be kept to a minimum, and the use of “double” filtration is not recommended. “Double” refers to filtering a sample twice using filters with progressively smaller pore sizes. This has been used to speed up filtration; however, it can cause excessive agitation.
- Open system techniques offer varying degrees of portability and ease of decontamination. In addition, changes in pressure and aeration/oxygenation can alter sample representativeness. Open system filtration is primarily driven by either pressure or vacuum mechanisms. For pressure, only pure, inert gas should be used (i.e., nitrogen). If a pump is used, the peristaltic is commonly employed. Whereas pressure “pushes” the sample using compressed gas or a pump, vacuum “pulls” the sample through the filter. Vacuum can cause extensive degassing, which can seriously alter metals concentrations (U.S. EPA, 1986a; EPRI, 1987; and Barcelona et al., 1985); therefore, vacuum is not recommended. The extensive alteration is due to an

¹¹For example, if the concentration of a chemical is much greater in unfiltered samples compared to filtered samples, it is likely that the majority of the chemical is sorbed onto particulate matter and not dissolved in the ground water.

exacerbation of the pressure decrease inherent with bringing a sample to the surface.

- **Filter samples using a polycarbonate or cellulose acetate filter.** Filtration media should be inert and selected to minimize bias. Polycarbonate membrane filters are recommended. Puls and Barcelona (1989b) have stated that this material should be used due to its more uniform pore size, ease of cleaning, and minimization of adsorptive losses. The NCASI (1982) also found polycarbonate to be most appropriate. Cellulose membranes and glass microfiber filters have been used commonly.
- **Prepare the filter prior to collecting the sample.** Filters must be pre-rinsed following manufacturer's recommendations to remove the residue from the manufacturing, packing, or handling. In-line filters should be flushed with sample water before collection to create a uniform wetting front.
- **Use of a 5 micron filter is recommended to ensure that the mobile fraction of turbidity is sampled.** While a 5 micron size filter is recommended, a filter with a different pore size may be used based upon site conditions. Theoretically, the filter pore size should equal the size of the largest mobile particles in the formation, although differences in particles passing different sizes may be lessened significantly by clogging. Traditionally, 0.45 micron filters have been used; however, different pore sizes can be used in specific instances if justified. Puls and Powell (1992) suggested a coarse filter size such as 5 micron. If estimates of dissolved metal concentrations are desired, use of 0.1 micron filters is recommended (Puls and Powell, 1992). Samples filtered with a medium with a small pore size (e.g., 0.1 micron for dissolved concentrations) may be appropriate for geochemical modeling (Puls and Powell, 1992).
- **The filtration medium should be disposed between wells**
- **If the ground water is highly turbid, periodic filter changes may be necessary (e.g., between samples)**
- **The filtration device, tubing, etc. should be appropriately decontaminated as sample-contacting equipment (see Decontamination Section)**

SAMPLE HANDLING, PRESERVATION, CONTAINERS, AND SHIPPING

Once a sample has been removed from a well, appropriate procedures should be utilized to containerize, preserve, and transport it to the laboratory. This ensures that an in-situ state is maintained as much as possible prior to analysis. Issues that should be considered include preservation, containers and labels, holding times, and shipping. Examples of containers, preservatives, and holding times for some chemicals are listed in Table 10.7. Deviating from Table 10.7 does not necessitate that a sample is invalid. Deviations should be recorded on the data reports and should be evaluated on a case-by-case basis. Appropriate preservation and handling should be coordinated with the laboratory prior to a particular sampling event.

Sample Acquisition and Transfer

Transfer to a container or filtration device should be conducted in a way that minimizes agitation and aeration. Samples should be transferred directly to the final container for laboratory submittal and not collected in a larger container with subsequent transfer to smaller containers. (Exceptions for filtration are allowable.) Care should be taken to prevent overfilling so that the preservative, if used, is not overly diluted. If no preservative is used, the containers should be rinsed with sample water prior to collecting the sample. After sealing, containers should not be opened in the field for any reason.

Special considerations are needed when sampling for VOCs. Samples should be placed in 40 ml glass vials until a meniscus is formed. Flow rate into the vials should be between 100 and 500 ml/min. The vials should be sealed with a fluorocarbon-lined cap. It is very important that no air bubbles or headspace remain to prevent the loss of VOCs. Check for air by inverting the vial and tapping. If any bubbles are present, the vial should be discarded and a new sample taken (U.S.EPA, 1996b; Yeskis and Zavala, 2002). The presence of air bubbles in a vial generally indicates either improper sampling technique or a source of gas evolution with the sample. If a sample cannot be obtained without air bubbles due to off-gassing, then the presence of air bubbles should be noted on the field log or field data sheet. Also, air bubbles may form during shipment to the laboratory. These bubbles do not necessarily invalidate the sample¹². The container should not be opened and "topped-off" to fill the additional head space (U.S. EPA, 1992). When sampling for VOCs, collection, handling, and containerization *should not* take place near a running motor or any type of exhaust system.

¹²Studies conducted by U.S. EPA indicate that "pea-sized" bubbles (1/4 inch or less in diameter) did not adversely affect data. These bubbles were generally encountered in wastewater samples.

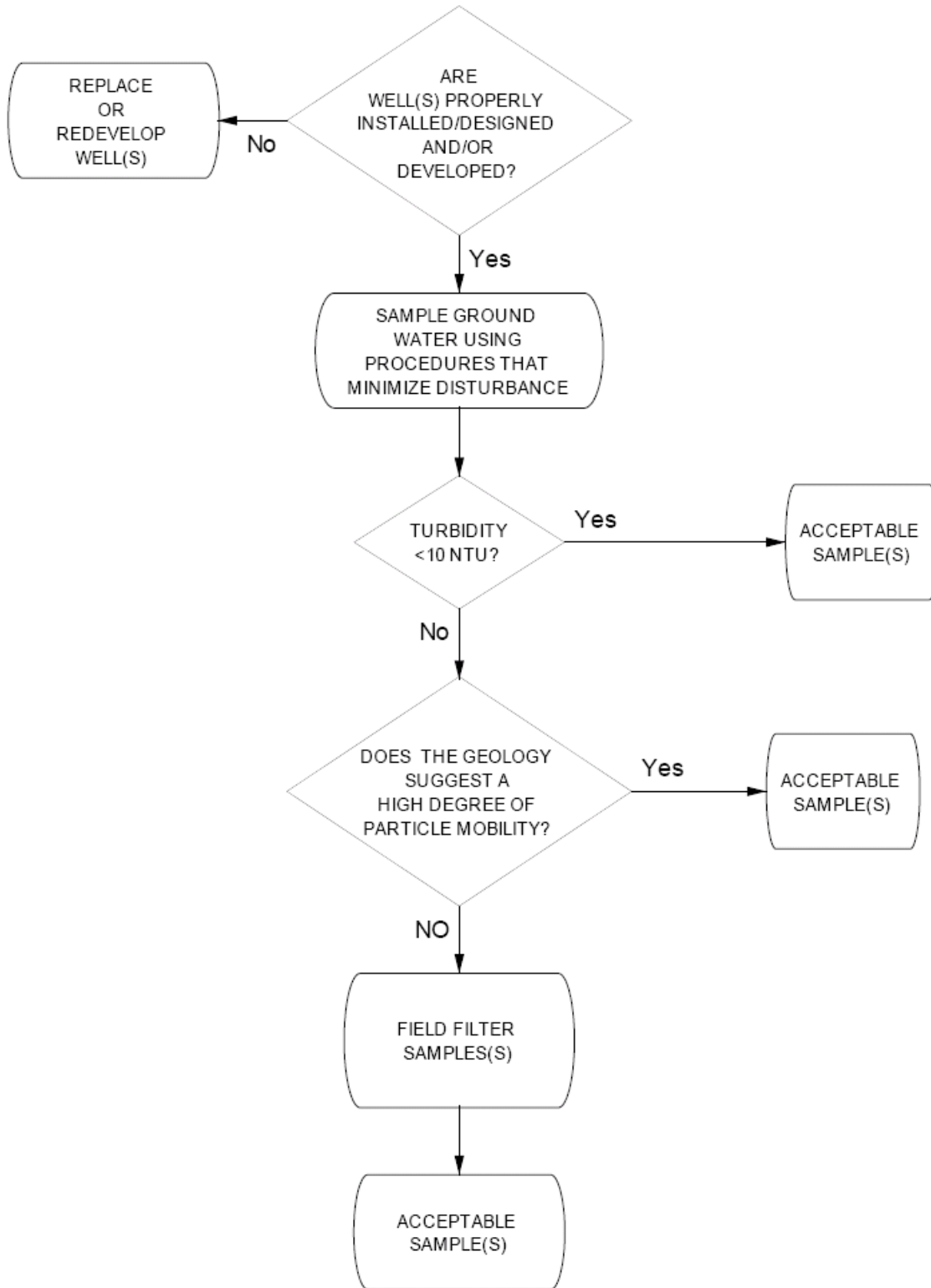

Figure 10.2 Ground water field filtration decision tree.

Samples should be collected and containerized in the following order of volatilization sensitivity (U.S. EPA, 1986a):

- Volatile organic compounds (VOCs).
- Purgeable organic carbon.
- Purgeable organic halogens.
- Total organic halogens (TOX).
- Total organic carbon (TOC).
- Extractable organics.
- Total metals.
- Dissolved metals.
- Phenols.
- Cyanide.
- Sulfate and chloride.
- Nitrate and ammonia.
- Radionuclides.

In addition to the sensitivity, the relative importance of each parameter should be evaluated on a site-by-site basis to establish sampling order protocol. Therefore, when a low-yielding well is being sampled, it may be necessary to change the order of sampling to ensure that a representative sample is collected for the most important constituents for a particular site.

Sample Splitting

Samples are often split into two separate portions and submitted to different laboratories to determine the accuracy of lab results. The proper procedure is to fill the two containers alternately until both are filled. However, if samples for VOC analysis are being collected, the first container should be completely filled, followed by filling of the split container.

Sample Preservation

Preservation is an important step that should be conducted to stabilize the collected sample and prevent physical and chemical changes from occurring during transport to the laboratory and storage before analysis. Preservation is intended to retard biological action, prevent hydrolysis of chemical compounds and complexes, and reduce volatility of constituents (U.S. EPA, 1982). Preservation methods generally are generally limited to pH control, chemical addition, refrigeration, and protection from light. Appropriate techniques(see Table 10.7), generally should be implemented immediately upon collection (and after filtration) to minimize changes that begin when a sample is exposed to the atmosphere. Any preservation used should be reported to the appropriate regulatory agency when submitting analytical results.

Sample preservation usually involves reducing or increasing the pH by adding an acid or a base. For example, acids are added to samples submitted for dissolved metals analysis because most metals exist in the dissolved state at low pH. If not preserved, most metals will oxidize and precipitate, which prevents representative analysis. If preserved in the field, the chemical preservative should be obtained from the laboratory contracted to analyze the sample and the appropriate aliquot placed in the sample container, preferably before entering the field. Many laboratories will provide sample bottles containing the appropriate amount

and type of preservative. Sampling personnel may want to carry limited amounts of some preservatives in the event that additional preservation is needed for a particular sample. However, if previous samples indicate that a sample may be acidic or alkaline, the amount of preservative should be discussed with the laboratory prior to sample collection.

Samples for temperature-sensitive parameters should be thermally preserved immediately after collection by placement into an insulated cooler maintained at a temperature of approximately $4^{\circ} \pm 2^{\circ} \text{C}$ ¹³ with ice or an ice substitute. Any deviation in temperature should be noted and assessed as to its impact on sample quality. Care should be taken to ensure that the paperwork and samples are not damaged by ice water. The laboratory should record whether or not the cooler contains any amount of visible ice. The presence of ice is sufficient to demonstrate that the samples are adequately preserved. If no ice is present, the laboratory should obtain a measure or estimate of the sample temperature upon receipt of the samples.¹⁴ This can be accomplished by either a temperature blank, or measuring the internal temperature of the cooler.

Containers and Sample Labels

Upon collection, samples should be contained properly to maintain integrity. Specifications on container design, including shape, volume, gas tightness, material construction, and use of cap liners, are defined for specific parameters or suites of parameters. For example, various fluorocarbons (i.e., Teflon), polyethylene plastic, or glass bottles with Teflon-lined lids are recommended for metals analysis. Samples to be analyzed for VOCs should be containerized in 40 ml glass vials. Specifications on containers are documented in parameter-specific analytical methods (e.g., SW-846). Clean containers can usually be obtained from the contracted laboratory. Note that analytical laboratories may not accept samples for analysis if the bottles have not been cleaned by their own laboratory. If cleaning is necessary, decontamination should be performed and appropriate blanks collected to verify cleanliness.

Samples should be properly identified with labels. The labels should be permanent and remain legible when wet. When sampling for VOCs the pen's ink may cause false positives, so labels should be completed and the ink allowed to dry before being affixed to the bottles (Wilson, 1995). The following information should be included:

- Sample field identification number (e.g., well location).
- Name or initials of collector.
- Date and time of collection.
- Place of collection.
- Parameters and method requested for analysis.
- Chemical preservatives used.

¹³The Environmental Laboratory Accreditation Program (NELAP) has adopted a standard temperature of $4 \pm 2^{\circ}\text{C}$ and has asked U.S. EPA to adopt this standard. U.S. EPA is proposing # 6EC (unfrozen)

¹⁴Some regulatory programs may require that the temperature of the cooler/sample be recorded regardless of whether there is visible ice.

Table 10.7 Common Examples of Containers, preservation, and holding times.

(Note: The preservative and holding times may vary with sampling procedures and method analysis. The table is partially based on U.S. EPA, Federal Register, Volume 69, No.66, April 6, 2004)

PARAMETER	CONTAINER	PRESERVATIVE ³	MAXIMUM HOLDING TIME
INORGANIC TESTS			
Acidity	P,G	Cool, 4∇2°C	14 days
Alkalinity	P,G	Cool, 4∇2°C	14 days
Ammonia	P,G	None	7days
		Cool, 4∇2°C; H ₂ SO ₄ to pH<2	28 days
Bromide	P,G	None required	28 days
Chloride	PG,	None required	28 days
Chlorine, residual	P,G	None required	Analyze immediately (within 15 minutes)
Cyanide, total	P,G	Cool 4∇2°C; NaOH to pH<12 ascorbic acid if oxidants (e.g., Chlorine) is present.)	14 days
Hardness	P.G	HNO ₃ to pH<2; H ₂ SO ₄ to pH<2	6 months
Kjeldahl and organic nitrogen	P.G	none	7 days
		Cool, 4∇2°C; H ₂ SO ₄ to pH<2	28 days
Nitrate	P,G	Cool, 4∇2°C	48 hours
Nitrate-nitrite	P,G	Cool, 4∇2°C; H ₂ SO ₄ to pH<2	28 days
Sulfate	P,G	Cool, 4∇2°C	28 days
Sulfide	P,G	Cool, 4∇2°C, add zinc acetate plus sodium hydroxide to pH > 9	7 days
Sulfite	P,G	None required	Analyze within 15 minutes
Metals, except Cr(VI) & Hg	P,G	HNO ₃ to pH<2 at least 24 hours prior to analysis	6 months
Chromium (Cr) VI	P,G	Cool , 4∇2°C	24 hours
Chromium (Cr) VI	P,G	use sodium hydroxide and ammonium sulfate buffer solution to pH 9.3 to 9.7 to extend holding time to 28 days	28 days
Mercury (Hg)	P,G	HNO ₃ to pH<2	28 days
ORGANIC TESTS			
Volatiles	G, Teflon-lined cap	Cool, 4∇2°C; 0.008% Na ₂ S ₂ O ₃ ³ ; HCl to pH<2 No head space	14 days

PARAMETER	CONTAINER	PRESERVATIVE ³	MAXIMUM HOLDING TIME
(Acrolein and acrylonitrile)	G, Teflon-lined septum	Cool, 4∇2°C; 0.008% Na ₂ S ₂ O ₃ ³ , adjust pH to 4-5	14 days
Dioxins and Furans	G, Teflon-lined cap	Cool, 4∇2°C	30 days until extraction, 45 days after extraction
Oil and grease	G	Cool, 4∇2°C; H ₂ SO ₄ or HCl to pH<2	28 days
Phenols	G, Teflon-lined cap	Na ₂ S ₂ O ₃	7 days until extraction, 40 days after extraction
PCBs	G, Teflon-lined cap	Cool, 4∇2°C	1 year
Pesticides	G, Teflon-lined cap	Cool, 4∇2°C; pH 5-9	1 year
RADIOLOGICAL Alpha, beta, and radium	P,G	HNO ₃ to pH<2	6 months

1 Polyethylene (P), Glass (G)

3 For some constituents free Chlorine must be removed by the appropriate addition of Na₂S₂O₃.

Shipping

When samples are to be shipped to a laboratory, an appropriate container should be used to protect and preserve them. Chests with ice or manufactured blue ice packets are commonly used. However, blue ice packets may not stand up to the rigors of shipping during warm weather. This routinely results in samples being received at the laboratory out of range for temperature. During warm weather, copious amounts of ice are generally recommended.

Forms such as a sampling request sheet and/or chain-of-custody containing pertinent information should be included (See page 10-48). Evidence tape also should be placed around the shipping container (and around each container, if desired), to guard against disturbance or tampering. It is important that, if samples are hazardous or potentially hazardous, they meet all federal and state transportation laws. At the state level, contact the Ohio Department of Transportation (ODOT) and the Public Utilities Commission of Ohio (PUCO) for additional information.

Not all samples will maintain complete stability, regardless of the preservation technique. Therefore, a limit on when analysis should take place has been set for most parameters (see Table 10.7). These "holding times" specify the maximum allowable time between sample collection and laboratory analysis. Depending on the specific circumstances, if one is exceeded, the sample may need to be discarded and a new sample obtained. Therefore, it is important that the time of sampling and transportation to the lab be documented to ensure that the limits are met. Be aware of analytical holding times and minimize the time between sampling and delivery to the laboratory.

DISPOSAL OF PURGED WATER

Though it is not the intent of this document to define/determine Ohio EPA's policy on disposal of purged water, the following guidance is provided. In general, purged water should be containerized until the ground water samples are analyzed. If the samples are free from contaminants (e.g., constituent concentrations are not above ambient/natural levels), then it may be acceptable to discharge the purged water onto the ground away from the wellhead but within the limits of the site/facility.¹⁵ Purged ground water that exhibits constituent concentrations above ambient/natural quality may need to be managed as wastewater or hazardous waste. If the water has been contaminated by a listed hazardous waste constituent or exhibits, a characteristic of hazardous waste as specified in 3745-51 of the Ohio Administrative Code, it will need to be managed as a hazardous waste. However, if the ground water is treated such that it no longer contains hazardous waste, the ground water would no longer be subject to regulation. Information on this subject can be found at: <http://www.epa.gov/correctiveaction/resource/guidance/remwaste/refrneces/12cntdin.pdf>

If the ground water is known or suspected to contain VOCs, the purged water should be screened with air-monitoring equipment, as well as water-quality field instruments. If these parameters and/or the facility background data suggest that the water is hazardous, it should be contained and disposed of properly as determined on a site-specific basis.

DECONTAMINATION PROCEDURES

If non-dedicated sampling equipment is used, it should be cleaned between wells to prevent cross-contamination. This includes all non-dedicated equipment that is submerged in a monitoring well or otherwise contacts a ground water sample. The level of decontamination is dependant on the level and type of suspected or known contaminants. A sampling event where high levels of contaminants are known or suspected would require the most stringent decontamination procedure, which may involve the use of solvent rinses. In general, solvent rinses should only be used when high levels of organic contaminants are known or suspected to be present. Care should be taken to avoid the any decontamination product (or breakdown products) from being introduced into the sample.

The decontamination area should be upwind of activities that may contribute dust or other contaminants to the solutions used. The process should occur on a layer of polyethylene sheeting to prevent surface soils from coming into contact with the equipment. The effects of cross-contamination can also be minimized by sampling the least contaminated wells first and then progressing to the more contaminated wells.

Table 10.8 outlines sequences and procedures that should be used (modified from ASTM D5088-02 and Yeskis and Zavala, 2002). The procedures are based on equipment contact with collected samples. Sample-contacting equipment includes non-dedicated bailers and pumps (i.e., devices used for purging and sampling), sample containers, tubing, downhole field parameter probes, water level probes, non-dedicated filtration equipment, etc. In most

¹⁵Under detection monitoring, it may be possible to discharge the purged water without containerizing if historical ground water records indicate that ground water quality beneath the site is similar to the ambient quality. The Division with authority over the site/facility should be contacted for approval of this disposal method.

instances, a distilled water rinse should be sufficient for field parameter measurement probes that are not lowered into wells. Many items are inexpensive and disposable (i.e., gloves, rope, tubing). Items dedicated to a well or disposed of between wells (i.e., gloves, cord, plastic sheet, bailer) would not need to be decontaminated. These items should be properly discarded¹⁶ and new materials provided for the next well.

Table 10.8 Decontamination procedure for ground water sampling equipment.

- Wash with non-phosphate detergent and potable water. Recommend using pressure spray filled with soapy water. Use bristle brush made from inert material to help remove visible dirt.
- Rinse with potable water.
- If analyzing samples for metals, may* need to rinse with 10% hydrochloric or nitric acid (note: dilute HNO₃ may oxidize stainless steel). This rinse is only effective on non-metallic surfaces.
- Rinse liberally with deionized/distilled water.
- If analyzing for organics, may* need to rinse with solvent-pesticide grade isopropanol, acetone, or methanol, alone or if required, in some combination. This solvent rinse should not be an analyte of interest. This rinse is important when a hydrophobic contaminant is present (such as LNAPL or DNAPL, high levels of PCB's etc.)
- Rinse liberally with deionized/distilled water.
- Air-dry thoroughly before using.
- Wrap with inert material if equipment is not to be used promptly.

*In most cases, solvent rinses will not be needed. Solvent/acid rinses may only be needed when high levels of contaminants are known to be present.

DOCUMENTATION

Field Sampling Logbook

A field logbook or field sampling forms should be completed and maintained for all sampling events. It should document the following for each well sampled¹⁷.

- Identification of well.
- Well depth.
- Static water level depth and measurement technique.
- Presence of immiscible layers and detection method.

¹⁶As discussed in the applicable sampling and analysis plan or equivalent protocol, e.g., a standard operation procedure.

¹⁷Items documented on the chain-of-custody do not need to be repeated in the field log.

- Thickness of immiscible layers, if applicable.
- Well yield - high or low.
- Purging device, purge volume and pumping rate.
- Time well purged.
- Measured field parameters.
- Collection method for immiscible layers (if applicable) and identification numbers.
- Sampling device used.
- Well sampling sequence.
- Sample appearance.
- Types of sample containers and sample identification numbers.
- Preservative(s) used.
- Parameters requested for analysis.
- Field analysis data and method(s).
- Sample distribution and transporter.
- Field observations on sampling event.
- Name of collector(s).
- Climatic conditions (e.g., air temperature, precipitation, and wind conditions)
- Problems encountered and any deviations made from the established sampling protocol.

Chain-Of-Custody

A chain-of-custody record should be established to provide the documentation necessary to trace sample possession from time of collection to final laboratory analysis. The record (Figure 10.3) should account for each sample and provide the following information: (U.S. EPA, 1992).

- Sample identification number.
- Printed name and signature of collector.
- Date and time of collection.
- Sample type (i.e., ground water).
- Identification of well.
- Number and types of containers.
- Parameters requested for analyses.
- Preservatives used.
- Carrier used.
- Printed name and signature of person(s) involved in the chain of possession¹⁸.
- Date/time samples were relinquished by sampler and received by the laboratory
- Internal temperature of shipping container upon opening at laboratory, if applicable.
- Special handling instructions (if any).

¹⁸Including all persons relinquishing the samples and all persons receiving the samples, but excluding the U.S. Postal Service, courier services, or commercial shipping companies.

Sample Analysis Request Sheet

A request sheet may also accompany samples on delivery to the laboratory. However, the chain-of-custody may be used as the sampling analysis request sheet if it contains the following information. Figure 10.4 is an example of a typical sheet.

- Sample type (e.g., ground water).
- Sample identification number.
- Name of person receiving the sample.
- Date and time of sample collection.
- Date of sample receipt.
- Analyses to be performed.
- Analysis method requested (if needed).
- Name of sampler.
- Internal temperature of shipping container upon opening at the laboratory.

Chain of Custody

Client Name/Address:		Send Report to:															
P.O. Number	Invoice to:											Number of Containers					
Samplers (Signature)	Project Number																
Sta No.	Date	Time	Comp.	Grab	Station Location												Remarks
Relinquished by (Signature)	Date / Time	Received by (Signature)										Date / Time	Received by (Signature)				
Method of Shipment:												Date / Time		Sample condition upon receipt:			

Figure 10.3 Example Change of Custody Form



WATER QUALITY LABORATORY CHEMICAL REPORT FORM

Station ID# _____

Date Received ___/___/___ Date Approved ___/___/___ Approved by: _____ Lab Number _____
 Station _____

Sample Use: Monthly Litigation DERR Complaint WQ Survey Compliance
 Sample Type: Grab Composite Sediment Tissue

Sample Collected by _____ Date & Time of Sample Begin

YY	MM	DD	HH	MM

Report Analysis to _____ Date & Time of Sample End

YY	MM	DD	HH	MM

Bill to: _____

Division: _____

CO NEDO NWDO SEDO SWDO CDO WQM Frequency & Duration of Composite Sample _____

FIELD MEASUREMENTS		PARAMETER	STORET CODE	RESULTS	DATE ANALYZED	ANALYST	SEDIMENT mg/kg
<input type="checkbox"/>	Chlorine, Total Resd., mg/l	P50060	.				
<input type="checkbox"/>	Conductivity, umhos/cm	P94	.				
<input type="checkbox"/>	Dissolved Oxygen, mg/l	P299	.				
<input type="checkbox"/>	Flow, CFS	P61	.				
<input type="checkbox"/>	pH, SU	P400	.				
<input type="checkbox"/>	Temperature, Water, °C	P10	.				
<input type="checkbox"/>	Gage Height, ft.	P65	.				
<input type="checkbox"/>			.				
<input type="checkbox"/>			.				
LABORATORY MEASUREMENTS		PARAMETER	STORET CODE	RESULTS	DATE ANALYZED	ANALYST	SEDIMENT mg/kg
<input type="checkbox"/>	Arsenic, Total As, ug/l	P1002	.				
<input type="checkbox"/>	Barium, ug/l	P1007	.				
<input type="checkbox"/>	Cadmium, Total Cd, ug/l	P1027	.				
<input type="checkbox"/>	Calcium, Total Ca, mg/l	P916	.				
<input type="checkbox"/>	Chromium, Diss, Hex Cr, ug/l	P1220	.				
<input type="checkbox"/>	Chromium, Total Cr, ug/l	P1034	.				
<input type="checkbox"/>	Copper, Total Cu, ug/l	P1042	.				
<input type="checkbox"/>	Iron, Total Fe, ug/l	P1045	.				
<input type="checkbox"/>	Lead, Total Pb, ug/l	P1051	.				
<input type="checkbox"/>	Magnesium, Total Mg, mg/l	P927	.				
<input type="checkbox"/>	Manganese, Total Mn, ug/l	P1055	.				
<input type="checkbox"/>	Mercury, Total Hg, ug/l	P71900	.				
<input type="checkbox"/>	Nickel, Total Ni, ug/l	P1067	.				
<input type="checkbox"/>	Potassium, Total K, mg/l	P937	.				
<input type="checkbox"/>	Selenium, Total Se, ug/l	P1147	.				
<input type="checkbox"/>	Sodium, Total Na, mg/l	P929	.				
<input type="checkbox"/>	Zinc, Total, ug/l	P1092	.				
<input type="checkbox"/>	Hardness, Total CaCO ₃ , mg/l	P900	.				
<input type="checkbox"/>			.				
<input type="checkbox"/>			.				
LABORATORY MEASUREMENTS		PARAMETER	STORET CODE	RESULTS	DATE ANALYZED	ANALYST	SEDIMENT mg/kg
<input type="checkbox"/>	Acidity, Total CaCO ₃ , mg/l	P70508	.				
<input type="checkbox"/>	Alkalinity, Total CaCO ₃ , mg/l	P410	.				
<input type="checkbox"/>	BOD, 5-day, mg/l	P310	.				
<input type="checkbox"/>	cBOD, 5-day, mg/l	P80082	.				
<input type="checkbox"/>	BOD, 20-day, mg/l	P324	.				
<input type="checkbox"/>	cBOD, 20-day, mg/l	P80087	.				
<input type="checkbox"/>	BOD, ultimate, mg/l	P319	.				
<input type="checkbox"/>	Carbon, Total Org, mg/l	P680	.				
<input type="checkbox"/>	COD, mg/l	P335	.				
<input type="checkbox"/>	Chloride, Cl, mg/l	P940	.				
<input type="checkbox"/>	Conductivity at 25°C, umhos/cm	P95	.				
<input type="checkbox"/>	Cyanide, Total, ug/l	P720	.				
<input type="checkbox"/>	Nitrate-Nitrite, as N, mg/l	P630	.				
<input type="checkbox"/>	Nitrite, as N, mg/l	P615	.				
<input type="checkbox"/>	Nitrogen, Ammonia as N, mg/l	P610	.				
<input type="checkbox"/>	Nitrogen, Total Kjeldahl, mg/l	P625	.				
<input type="checkbox"/>	Oil and Grease, mg/l	P556	.				
<input type="checkbox"/>	pH, SU	P403	.				
<input type="checkbox"/>	Phenolics, ug/l	P32730	.				
<input type="checkbox"/>	Phosphorus, Total, mg/l	P665	.				
<input type="checkbox"/>	Residue, Total, mg/l	P500	.				
<input type="checkbox"/>	Residue, Total Flt, mg/l	P70330	.				
<input type="checkbox"/>	Residue, Total Nflt, mg/l	P530	.				
<input type="checkbox"/>	Sulfate, SO ₄ , mg/l	P945	.				
<input type="checkbox"/>	Fecal Coliform, MF, #/100 ml	P31616	.				
<input type="checkbox"/>	Total Coliform, MF, #/100 ml	P31501	.				
<input type="checkbox"/>	Fecal Strept		.				
<input type="checkbox"/>			.				
<input type="checkbox"/>			.				

PRESERVATIVES

NaOH H₂SO₄, nutrients Other
 HNO₃ H₂SO₄, phenolics Filtered
 N/P H₂SO₄, oil and grease

COMMENTS:

DISTRIBUTION:
 WHITE-LAB
 GREEN-STORET
 CANARY-DISTRICTS
 PINK-DISTRICT
 EPA 4700

Figure 10.4 Example Analysis Request Form

FIELD QUALITY ASSURANCE/QUALITY CONTROL (QA/QC)

To assure adequate QA/QC in the field, the sampling plan should be followed consistently. To verify if procedures are contaminating ground water samples, a variety of samples and blanks need to be collected and analyzed. The following are typical checks:

- **Field Duplicates** - Field duplicates are samples collected as close to each other in time and space as practical at a specific location. Ultimately, upon analysis, both should yield the same results within an acceptable range. Excessive variation could indicate problems with the sampling procedures or problems with the analysis. If strict protocols are followed, variability as a result of the field procedures should be minimal. At minimum, duplicates should be collected at a frequency of one per twenty samples (Yeskis and Zavala, 2002), one per week, and one per sampling event.
- **Trip Blanks** - Trip blanks are generally prepared by the laboratory before entering the field. Containers are filled with analyte-free, distilled, deionized water and sealed. These blanks are taken to the field and handled along with the collected samples, thereby acting as a control sample to determine potential VOC contamination from the containers themselves. Trip blanks should be included in each cooler containing VOC samples. At, minimum, at least one trip blank should accompany each sampling event. Trip blanks are never opened in the field.
- **Equipment Blanks** - Whenever non-dedicated sampling equipment is used, equipment/field blanks should be collected. An equipment/field blank is obtained by passing analyte-free, distilled, deionized water through a cleaned sampling apparatus (pump, bailer, filtration gear, etc.) and collecting it in a clean container. This blank is used to assess the effectiveness of the decontamination procedures implemented between sampling locations. Ideally, equipment blanks should be collected after sampling the well(s) that historically show(s) highest levels of contamination. They should be collected at a frequency of one blank per 20 samples (Yeskis and Zavala, 2002), one per week, and one per sampling event.
- **Field Blanks** - Field blanks (also known as ambient blanks) are containers containing de-ionized water, which are opened and remain open during field operations. They are used to assess whether there is a potential for sample contamination from air sources in the surrounding area. Analysis from field blanks cannot be used to adjust sample results. Field blanks are rarely collected as a control measure.
- **Temperature Blank** - A temperature blank may be used to estimate the sample temperature at the time the sample is received by the laboratory (ASTM, D6517-00).

Trip blanks and equipment blanks may not be necessary if it is assumed that any chemical of concern detected is present in the ground water or confirmation sampling and analysis is conducted.

All duplicates and blanks should be subjected to the same analysis as the ground water samples. The results are used to determine if proper procedures were followed. Blank

contamination can result from improper decontamination of sampling equipment, poor sampling and handling procedures, contaminated rinse water or preservatives, or the interaction between sample and container. The concentration levels of any contaminants found should **not** be used to correct the ground water data. Blank contamination should trigger a re-evaluation of procedures to determine the source of the problem.

GROUND WATER SAMPLE ANALYSIS

SELECTION OF ANALYTICAL METHOD

The selection of the method for ground water analysis is determined by the parameters of interest and the purpose of the investigation. Several methods may exist for the same parameter. The selected analytical method should be capable of accurately measuring the constituent of concern in the sample. Some regulatory programs may mandate that the analytical method be U.S. EPA-approved or may suggest a preferred method. Therefore, it is recommended that one check with the regulatory program prior to specifying an analytical method.

There are different methods that are approved by U.S. EPA. The following web sites may be helpful in choosing an appropriate method:

<http://www.epa.gov/epahome/standards.html> (U.S. EPA tests methods and guidance),
<http://www.epa.gov/epaoswer/hazwaste/test/main.htm> (U.S. EPA, SW-846 manual), and
<http://www.epa.gov/SW-846/info.htm> (U.S. EPA Web site that provides links to other sites).

The most important analytical requirement generally is the detection limit. For example, claims that no contamination is present in ground water samples are correct only to the quantitative extent that the analysis is capable of detecting the contaminant (Vitale et al., 1991). This level is known as the method detection limit (MDL). The MDL is the minimum concentration of a substance that can be measured and reported with a 99% confidence that the analyte concentration is greater than zero. Useless data may result if the detection limits are not low enough for the purpose of the investigation. For example, the primary objective often is to determine the risk to human health and the environment. In this case, the MDLs should be at or below human health-based criteria and environmental-based criteria.

Due to matrix interference and irregularities in instruments, the MDL may not always be obtained. In addition, the actual detection limit will be higher for samples that require dilution or reduced size to avoid saturation of the detector. The actual limit attained during the analysis should be reported with the data.

LABORATORY QUALITY ASSURANCE/QUALITY CONTROL (QA/QC)

It is not the intent of this document to discuss laboratory QA/QC procedures. Procedures, methods, and levels of quality control are discussed in various U.S. EPA publications (1979a, 1979b, and 1986b). Laboratory QA/QC may include, but may not be limited to, qualifications, performance, matrix effects (e.g., blanks and matrix spikes), documentation, and record reporting. For sites under the CERCLA process, Ohio EPA-DERR (1990) has established set guidelines and specifications for preparing quality assurance project plans.

For additional information on QA/QC plans the reader is referred to the Ohio EPA, Division of Hazardous Waste [Data Validation Guidance](#).

To obtain reliable results, appropriate laboratory procedures and methods should be followed. An extensive laboratory QA/QC program ensures the production of scientifically sound, defensible results that can be documented and verified. Whether Ohio EPA review is required depends on the regulatory program involved. For example, submittal of a laboratory QA/QC plan is not required for sites undergoing RCRA closure (Ohio EPA, DHWM Program); however, the owner/operator should demonstrate that the laboratory has a plan that contains the elements listed by U.S. EPA (1986b). A laboratory QA/QC plan should be approved for sites remediated under the CERCLA process (Ohio EPA, DERR program).

An appropriate level of laboratory QA/QC data should be submitted with sample results to allow verification that the samples were properly handled and analyzed. A particular regulatory program may dictate the amount and type of data. All QA/QC data should be kept and made available upon request.

This data may be valuable for explaining outliers and questionable results. However, the laboratory QC results should not be used to alter the sample analytical data. A report on analytical data is incomplete without some verification of laboratory QA/QC.

REFERENCES

- Aller, L., T. W. Bennett, G. Hackett, R. J. Petty, J. H. Lehr, H. Sedoris, D.M. Nielsen, and J. E. Denne. 1991. Handbook of Suggested Practices for the Design and Installation of Ground Water Monitoring Wells. Environmental Monitoring Systems Laboratory, Office of Research and Development, U.S. Environmental Protection Agency. Las Vegas, Nevada. EPA/600/4-89/034. (In cooperation with National Water Well Association).
- American Society for Testing and Materials (ASTM), Method D4448-01. Standard Guide for Sampling Groundwater Monitoring Wells. American Society for Testing and Material Standards. West Conshohocken, Pennsylvania.
- ASTM, Method D4750-87(Reapproved 2001) Standard Test Method For Determining Subsurface Liquid Levels in a Borehole or Monitoring Well (Observation Well). American Society for Testing and Material Standards. West Conshohocken, Pennsylvania.
- ASTM, Method D5088-02. Practice for Decontamination of Field Equipment Used at Nonradioactive Waste Sites. American Society for Testing and Material Standards. West Conshohocken, Pennsylvania.
- ASTM, Method D6634-01. Standard Guide for the Selection of Purging and Sampling Devices for Ground-Water Monitoring Wells. American Society for Testing and Material Standards. West Conshohocken, Pennsylvania.
- ASTM D6517-00. Standard Guide for Field Preservation of Ground-Water Samples. American Society for Testing and Material Standards. West Conshohocken, Pennsylvania.
- ASTM, Method D6699-01. Standard Practice for Sampling Liquids Using Bailers. American Society for Testing and Material Standards. West Conshohocken, Pennsylvania
- ASTM Method D6771-02. Standard Practice for Low-Flow Purging and Sampling for Wells and Devices Used For Ground Water Quality Investigations. American Society for Testing and Material Standards. West Conshohocken, Pennsylvania
- Anastas, M. Y. and H. J. Belknap. 1980. Summary of Available Portable VOC Detection Instruments, PEDCO Environmental. EPA Report No. 340/1-80-010.
- Backhus, D.A., J.N. Ryan, D.M. Groher, J.K. MacFarlane, and P.M. Gschwend. 1993. Sampling Colloids and Colloid-Associated Contaminants in Ground Water. Ground Water, Vol. 31, No. 3, pp. 466-479.
- Barcelona, M. J., J. P. Gibb, J. A. Helfrich, and E. E. Garske. 1985. Practical Guide for Ground-Water Sampling. Illinois State Water Survey. Champaign, Illinois. Contract Report 374.

- Barcelona, M.J., J.A. Helfrich, and E.E. Garske. 1988. Verification of Sampling Methods and Selection of Materials for Ground Water Contamination Studies. In A.G. Collins and A.I. Johnson (editors), Ground-Water Contamination: Field Methods. ASTM STP963 ASTM, Philadelphia, PA.
- Barcelona, M. J., H. A. Wehrmann, M. R. Schock, M. E. Sievers, and J. R. Karny. 1989. Sampling Frequency for Ground-Water Quality Monitoring. U.S. EPA Project Summary. EPA/600/S4-89/032.
- Barcelona, M.J., H.A. Wehrman, and M.D. Varljen. 1994. Reproducible Well-Purging Procedures and VOC Stabilization Criteria for Ground-Water Sampling. Ground Water. Vol. 32, No. 1, pp. 12-22.
- Brown, G. E., D. A. DuBose, W. R. Phillips and G. E. Harris. 1980. Response Factors of VOC Analyzers Calibrated with Methane for Selected Organic Chemicals. U.S. EPA, Research Triangle Park, EPA 600/2-81-002.
- Brownlow, A.H. 1979. Geochemistry. Prentice-Hall. 498 p.
- Dalton, M. G., B. E. Huntsman, and K. Bradbury. 1991. Acquisition and Interpretation of Water-Level Data. In: D. M. Nielsen (editor), Practical Handbook of Ground-Water Monitoring. Lewis Publishers, Inc. Chelsea, Michigan. pp. 367-397.
- Deutsch, W.J. 1997. Groundwater Chemistry, Fundamentals and Applications to Contamination. CRC Press, LLC. 221 p.
- DuBose, D. A., G. E. Brown, and G. E. Harris. 1981. Response of Portable VOC Analyzers to Chemical Mixtures. U.S. EPA, Research Triangle Park, EPA 600/2-81-110.
- EPRI (Electrical Power Research Institute). 1985. Field Measurement Methods for Hydrogeologic Investigations: A Critical Review of Literature. EPRI EA-4301. Environmental, Physical and Chemical Program, Energy Analysis Division. Palo Alto, California.
- EPRI. 1987. Sampling Guidelines for Ground Water Quality. EA-4952, Research Project 2485-1. Land and Water Quality Studies Program, Environmental Division. Palo Alto, California.
- Garner, S. 1988. Making the most of Field-Measurable Ground Water Quality Parameters. Ground Water Monitoring Review. Vol. 8, No. 3, pp. 60-66.
- Gibb, J.A., R.M. Schuller, and R.A. Griffin. 1981. Procedure for the Collection of Representative Water Quality Data From Monitoring Wells. Illinois State Water Survey and Illinois State Geological Survey Cooperative Ground Water Report 7, 61pp.
- Gibbons, R.D. and M.N. Sara. Statistical Comparison of Metals Concentrations in Filtered and Unfiltered Ground-Water Samples, *in* Ground Water Sampling, A Workshop Summary: Dallas, Texas. November 30 - December 2, 1993. U.S. EPA Office of Research and Development, EPA/600/R-94/205, pp. 54-58.

- Gillham, R. W., M. J. L. Robin, J. F. Barker and J. A. Cherry. 1983. Ground Water Monitoring and Sample Bias. Department of Earth Science, University of Waterloo, Ontario. API Publication 4367. Washington, D.C.
- Heath, R.C. 1987. Basic Ground-Water Hydrogeology. United States Geological Survey Water-Supply Paper 2220, 84p.
- Hem, J. H. 1992. Study and Interpretation of the Chemical Characteristics of Natural Water (Third Edition). United States Geological Survey Water-Supply Paper 2254. 264 p.
- Herzog, B., L. S. F. Chou, J. R. Valkenburg, and R. A. Griffin. 1988. Changes in Volatile Organic Chemical Concentrations After Purging Slowly Recovering Wells. Ground Water Monitoring Review. Vol. 8, No. 4.
- Imbrigiotta, T. E., J. Gibs, T. V. Fusillo, G. R. Kish, and J. J. Hochreiter. 1988. Field Evaluation of Seven Sampling Devices for Purgeable Organic Compounds in Ground Water. In: A. G. Collins and A. J. Johnson (editors), Ground Water Contamination: Field Methods, ASTM STP 963. American Society for Testing and Material Standards. Philadelphia, Pennsylvania. pp. 258-273.
- ITRC, 2004. Technical and Regulatory Guidance for Using Polyethylene Diffusion Bag Samplers to Monitor Volatile Organic Compounds in Groundwater. Interstate Technology & Regulatory Council. 39 pp.
- Karklins, Steven, 1996. Ground Water Sampling Desk Reference. Wisconsin Department of Natural Resources-Bureau of Drinking Water and Groundwater.
- Kasper, R. B. and J. A. Serkowski. 1988. Evaluation of Sampling Equipment for RCRA Monitoring in a Deep Confined Aquifer. Second Outdoor Action Conference, National Water Well Association. Dublin, Ohio. Vol 1, pp. 445-485.
- Kearl, P. M., N. E. Korte, and T. A. Cronk. 1992. Suggested Modifications to Ground Water Sampling Procedures Based on Observations from the Colloidal Borescope. Ground Water Monitoring Review. Vol. 12, No. 2, pp. 155-161.
- Kearl, P. M., N. E. Korte, M. Stites, and J. Baker. 1994. Field Comparison of Micropurging vs. Traditional Ground Water Sampling. Ground Water Monitoring and Remediation. Vol. 14, No. 4, pp. 183-190.
- Lee, G. F. and R. A. Jones. 1983. Guidelines for Sampling Ground Water. Journal of the Water Pollution Control Federation. Vol. 55, No. 1. pp. 92-96.
- Martin-Hayden, J.M. 2000. Sample Concentration Response to Laminar Wellbore Flow: Implications to Ground Water Data Variability. Ground Water, Volume 38, Number 1, pp 12-19.
- McCarthy, J.F. and J.M. Zachara. 1989. Subsurface Transport of Contaminants. Environmental Science and Technology, Vol. 5, No. 23, pp. 496-502.

- Muska, C. F., W. P. Colven, V. D. Jones, J. T. Scogin, B. B. Looney, and V. Price, Jr. 1986. Field Evaluation of Ground Water Sampling Devices for Volatile Organic Compounds. In: Proceedings of the Sixth National Symposium and Exposition of Aquifer Restoration and Ground Water Monitoring. National Water Well Association. Dublin, Ohio. pp. 235-246.
- National Council of the Paper Industry for Air and Stream Improvement (NCASI). 1982. A Guide to Ground Water Sampling. Technical Bulletin No. 362. New York, New York.
- NCASI. 1984. A Laboratory Study of Four Methods of Sampling Ground Water for Volatile Organic Compounds. Technical Bulletin No. 441.
- Nielsen, D.M. and Nielsen, G.L. 2006. Ground-Water Sampling In: D. M. Nielsen (editor), Practical Handbook of Environmental Site Characterization and Ground-Water Monitoring. Taylor & Francis Group, CRC Press. Boca Raton. pp. 959-1112.
- Nielsen, D.M. and Nielsen, G.L. 2002 Technical Guidance on Low-Flow Purging & Sampling and Minimum-Purge Sampling. Second Edition. The Nielsen Environmental Field School, Inc. Galena, Ohio.
- Nielsen, D. M. and G. L. Yeates. 1985. A Comparison of Sampling Mechanisms Available for Small-Diameter Ground Water Monitoring Wells. Ground Water Monitoring Review. Vol. 5, No. 2, pp. 83-89.
- Nightingale, H.I. and W.C. Bianchi. 1977. Ground-Water Turbidity Resulting From Artificial Recharge: Ground Water, Vol. 15, No. 2, pp. 146-152.
- Ohio EPA. 2004. Tier 1 Data Validation Manual. Division of Hazardous Waste Management. Columbus, Ohio.
- Ohio EPA. May 2003. 2002 305(b) Report, Ohio's Ground Water Quality. Division of Drinking and Ground Waters. 78 p. Columbus, Ohio.
- Ohio EPA, 1990. Guidelines and Specifications for Preparing Quality Assurance Project Plans. Division of Emergency and Remedial Response. Columbus, Ohio.
- Oliveros, J. P., D. A. Vroblesky, and M. M. Lorah. 1988. Increasing Purging Efficiency Through the Use of Inflatable Packers. Proceedings of the Second Outdoor Action Conference on Aquifer Restoration, Ground Water Monitoring and Geophysics. National Water Well Association. Dublin, Ohio. Vol 1, pp. 457-470
- Parker, L.V. 1994. The Effects of Ground Water Sampling Devices on Water Quality: A Literature Review. Ground Water Monitoring and Remediation. Vol. 14, No. 2, pp. 130-141.
- Parsons (Parsons Engineering Science, Inc.), 2003. Final Comprehensive Results Report for the Passive Diffusion Bag Sampler Demonstration Prepared for Air Force Center for Environmental Excellence Technology Division.

- Paul, D.G., C.D. Palmer and D.S. Cherkauer. 1988. The Effects of Construction, Installation, and Development on the Turbidity of Water in Monitoring Wells in Fine-Grained Glacial Till: Ground Water Monitoring Review. Vol. 8, No. 1, pp. 73-82.
- Pennino, J.D. 1988. There's No Such Thing as a Representative Ground Water Sample (Editorial). Ground Water Monitoring Review. Vol. 8, No. 3, pp. 4-9.
- Pohlmann, K. F. and Hess, J. W. 1988. Generalized Ground Water Sampling Device Matrix. Ground Water Monitoring Review. Vol. 8, No. 4, pp. 82-85.
- Powell, R.M., and P.W. Puls. 1993. Passive Sampling Ground Water Monitoring Wells Without Purging: Multilevel Well Chemistry and Tracer Disappearance. Journal Contaminant Hydrology, Volume 12, pp. 51-77.
- Powell, R.M., and P.W. Puls. (no date). Sampling of Ground Water Monitoring Wells, Part 3- Low Flow and Passive Purging and Sampling. <http://www.powellassociates.com>
- Puls, R.W., D.A. Clark, B. Bledsoe, R.M. Powell, C.J. Paul. 1992. Metals in Ground Water: Sampling Artifacts and Reproducibility. Hazardous Wastes and Hazardous Materials. Vol. 9, No. 2, pp. 149-162.
- Puls, R. W. and M. J. Barcelona. 1996. Low-Flow (Minimal Drawdown) Ground Water Sampling Procedure. Ground Water Issue Paper, U.S. Environmental Protection Agency. EPA/540/S-95/504. 12pp.
- Puls, R. W. and M. J. Barcelona. 1989a. Filtration of Ground Water Samples for Metals Analysis. Hazardous Waste and Hazardous Materials. Vol. 6, No. 4, pp. 385-393.
- Puls, R. W. and M. J. Barcelona. 1989b. Ground Water Sampling for Metals Analyses. U.S. EPA Superfund Ground Water Issue, EPA/540/4-89/001.
- Puls, R. W., J. H. Eychaner and R. M. Powell. 1990. Colloidal-Facilitated Transport of Inorganic Contaminants in Ground Water: Part I. Sampling Considerations. U.S. EPA, Environmental Research Brief. EPA/600/M-90/023. Robert S. Kerr Environmental Research Laboratory. Ada, Oklahoma.
- Puls, R. W. and R. M. Powell. 1992. Acquisition of Representative Ground Water Quality Samples for Metals. Ground Water Monitoring Review. Vol. 12, No. 3, pp. 167-176.
- Rose, S., and A. Long. 1988. Monitoring Dissolved Oxygen in Ground Water: Some Basic Considerations. Ground Water Monitoring Review. Vol. 8, No. 1, pp. 93-97.
- Schrale, G. and J. F. Brandywyk. 1979. An Acoustic Probe For Precise Determination of Deep Water Levels in Boreholes. Ground Water. Vol. 17, No. 1, pp. 110-111.

- Stolzenburg, T. R. and D. G. Nichols. 1986. Effects of Filtration Method and Sampling on Inorganic Chemistry on Sampled Well Water. Proceedings of Sixth National Symposium and Exposition on Aquifer Restoration and Ground Water Monitoring. National Water Well Association. Dublin, Ohio. pp. 216-234.
- Tai, D. Y., K. S. Turner and L. A. Garcia. 1991. The Use of a Standpipe to Evaluate Ground Water Samplers. Ground Water Monitoring Review. Vol. 11, No. 1, pp. 125-132.
- Testa, S.M., and D.L. Winegardner. 1991. Restoration of Petroleum-Contaminated Aquifers. Lewis Publishers, Inc. 269 p.
- U.S. EPA. 2004. Guidelines Establishing Test Procedures for the Analysis of Pollutants Under the Clean Water Act; National Primary Drinking Water Regulations; and National Secondary Drinking Water Regulations; Analysis and Sampling Procedure; Proposed Rule. Federal Register, Tuesday, April 6, 2004. Environmental Protection Agency.
- U.S. EPA. 2001. Environmental Investigations Standard Operating Procedures and Quality Assurance Manual. United States Environmental Protection Agency, Region IV. Athens, Georgia.
- U.S. EPA. 2000. Guidance for the Data Quality Objectives Process. United States Environmental Protection Agency, Washington, D.C. EPA/600/r-96/055
- U.S. EPA. 1997. Proceedings of the Symposium on Natural Attenuation of Chlorinated Organics in Ground Water. EPA/540/R-97/504. Office of Research and Development. Washington, D.C.
- U.S. EPA 1996a. How to Effectively Recover Free Product at Leaking Underground Storage Tank Sites. A Guide for State Regulators. United States Environmental Protection Agency. Office of Underground Storage Tanks, OSWER National Risk Management Research Laboratory. <http://www.epa.gov/OUST/pubs/fprg.htm>
- U.S. EPA. 1996b. Test Methods: SW846, Chapter 4-Organic Analysis. Revision 3. United States Environmental Protection Agency.
- U.S. EPA. 1989. Risk Assessment Guidance for Superfund. Volume 1. Human Health Evaluation Manual (Part A). EPA/540/1-89/002. Office of Emergency and Remedial Response. Washington, D.C.
- U.S. EPA. 1991. Exposure Point Concentrations in Ground Water. United States Environmental Protection Agency, Region III. Office of Superfund, Hazardous Waste Management. EPA/903/8-91/002.
- U.S. EPA. 1992. RCRA Ground-Water Monitoring Draft Technical Guidance. Office of Solid Waste. Washington, D.C.

- U.S. EPA. 1986a. RCRA Ground Water Technical Enforcement Guidance Document. Office of Waste Program Enforcement, Office of Solid Waste and Emergency Response. OSWER 9950.1. Washington, D.C.
- U.S. EPA. 1986b. Test Methods For Evaluating Solid Waste, SW846. Third Edition. Office of Solid Waste and Emergency Response. Government Printing Office. Washington, D.C.
- U.S. EPA 1982. Handbook for Sampling and Sample Preservation of Water and Wastewater. EPA-600/4-82-029. (Available through National Technical Information Service, PB 83-124503. Springfield, VA).
- U.S. EPA 1979a. Methods For Chemical Analysis of Water and Wastes. Environmental Monitoring and Support Laboratories. EPA/600/4-79/020. Cincinnati, Ohio. (Available through National Technical Information Service, PB84-128677. Springfield, VA.).
- U.S. EPA 1979b. Handbook of Analytical Quality Control in Water and Wastewater Laboratories. Environmental Support Laboratories. EPA 600/4-79/019. Cincinnati, Ohio.
- U.S.G.S. No date. Use of Passive Diffusion Samplers for Monitoring Volatile Organic Compounds in Ground Water. USGS Fact Sheet 088-1. URL: <http://pubs.water.usgs.gov/fs-088-01>
- Vitale, R. J., O. Braids, and R. Schuller. 1991. Ground-Water Sample Analysis. In David M. Nielsen (editor), Practical Handbook for Ground-Water Monitoring. Lewis Publishers, Inc. Chelsea, Michigan. pp. 501-540.
- Vroblesky, Don, A. 2001. User's Guide for Polyethylene-Based Diffusion Bag Samplers to Obtain Volatile Organic Compound Concentrations in Wells. Part 1: Deployment, Recovery, Data Interpretation, and Quality Control and Assurance. U.S.G.S Water-Resource Investigation Report 01-4060. Part 2: Field Tests, U.S.G.S Water-Resource Investigation Report 01-4061.
- Vroblesky, Don and Thomas Hyde. 1997. Diffusion Samplers as an Inexpensive Approach to Monitoring VOCs in Ground Water. Ground Water Monitoring Review, Vol. 17, No. 3, pp. 177-184.
- Wiedemeier, T.H., M.A. Swanson, D.E. Moutoux, J.T. Wilson, D.H. Kampbell, J.E. Hansen, and P. Haas. 1997. Overview of the Technical Protocol for Natural Attenuation of Chlorinated Aliphatic Hydrocarbons in Ground Water Under Development for the U.S. Air Force Center for Environmental Excellence in Proceedings of the Symposium on Natural Attenuation of Chlorinated Organics in Ground Water. EPA/540/R-97/504. Office of Research and Development. Washington, D.C., pp. 37-61.

Wilde, F.D., D.B. Radtke, J.Gibs, and R.T. Iwatsubo, eds. 1998. National Field Manual for the Collection of Water Quality Data. U.S. Geological Survey Techniques of Water-Resources Investigation, Book 9, Handbooks for Water Resources Investigation. Variously paginated.

Wilson, N. 1995. Soil and Ground Water Sampling. Lewis Publishers.

Yeskis, Douglas, and Bernard Zavala. 2002. Ground-Water Sampling Guidelines for Superfund and RCRA Project Managers. United States Environmental Protection Agency, Technology Innovative Office, Office of Solid Waste and Emergency Reponse Washington D.C.

APPENDIX A

ADDITIONAL INFORMATION FOR SAMPLING WATER SUPPLY WELLS

Water supply wells are often sampled as part of characterizing a potential pollutant source. This information is helpful for characterizing the extent of a plume and to ensure that the public has a safe source of water. The name(s), address, and phone numbers of the resident or water supply owner/operator, should be obtained, so that they can be informed of the results.

Many of the same techniques and protocol for sampling monitoring wells also apply to collecting a representative sample from a water supply. This includes: planning and preparation; sample preservation, sample containers, handling and shipping; and documentation. These are discussed in other sections of this document. However, there are additional conditions/procedures that must be considered when selecting the sampling point and the actual sample. These additional considerations are summarized below.

Selecting the Sampling Point

The following should be considered when choosing the location to collect a water sample:

- Prior to sampling, existing information such as well construction, yield and depth should be obtained. The Ohio Department of Natural Resources, Division of Water keeps records of all well logs. Well log records can be searched on-line at <http://www.dnr.state.oh.us/water/>. If a well log record does not exist, then the local health department should be contacted to see if they have any records. Also if no log exists, the depth of the well should be measured, if possible, and compared to the ODNR Ground Water Resource maps. These maps can be obtained at the above cited web link.
- The intake of the water supply well should be screened/opened to the targeted ground water zone of interest.
- The tap selected for sample collection should be the closest to the water source and prior to any treatment system. Also, if possible, the sampling point should be prior to entering the residence, office, building, or holding tanks etc. It is noted that for some small systems the first tap down stream from the pressure tank and upstream from any water treatment may be the best tap available.
- The sampling tap should be protected from exterior contamination associated with being too close to a sink bottom or to the ground. Contaminated water or soil from the faucet exterior may enter the bottle during the collection procedure since it is difficult to place a bottle under a low tap without grazing the neck interior against the outside faucet surface. If the tap is too close to the ground for direct collection into the appropriate container, it is acceptable to use a smaller (clean) container to transfer the sample to a larger container. The smaller container should be made of glass or stainless steel, or of the same composition of the sample bottles. Also, if samples are

to be collected for bacteria, then the tap needs to be disinfected prior to sampling. The laboratory should provide you with their tap disinfection procedures.

- Leaking taps that allow water to discharge from around the valve stem handle and down the outside of the faucet, or taps in which water tends to run up on the outside of the lip, should be avoided as sampling locations.
- Disconnect any hoses, filters, or aerators attached to the tap before sampling. These devices can harbor a bacterial population if they are not routinely cleaned or replaced when worn or cracked. If disconnection from an aerator, or treatment system, is required, permission should be obtained from the well owner.
- Taps where the water flow is not constant should be avoided because temporary fluctuation in line pressure may cause clumps of microbial growth that are lodged in a pipe section or faucet connection to break loose. A smooth flowing water stream at moderate pressure without splashing should be used. The sample should be collected without changing the water flow. It may be appropriate to reduce the flow for the volatile organic compounds aliquot to minimize sample agitation.
- When sampling for bacterial content, the sample container should not be rinsed before use due to possible contamination of the sample container or removal of the thiosulphate dechlorinating agent (if used). When filling any sample container, care should be taken that no splashing drops of water from the ground or sink enter into either the bottle or cap.

Sampling Technique

The following procedures should be followed when collecting samples from water supplies:

1. Ideally, the sample should be collected from a tap or spigot located at or near the well head or pump house and before the water supply is introduced into any storage tanks or treatment units. If the sample must be collected at a point in the water line beyond a pressurization or holding tank, a sufficient volume of water should be purged to provide a complete exchange of fresh water into the tank and at the location where the sample is collected. If the sample is collected from a tap or spigot located just before a storage tank, spigots located inside the building or structure should be turned on to prevent any backflow from the storage tank to the sample tap or spigot. It is generally advisable to open several taps during the purge to ensure a rapid and complete exchange of water in the tanks.
2. If the water system is not actively running, purge the system for at least 15 minutes. Systems that are actively pumped may require less purging (e.g., 3-5 minutes). After purging for several minutes, measure the stabilization parameters (See page 10-27). Continue to monitor these parameters until three consistent readings are obtained.
3. After three consistent readings have been obtained, samples may be collected. Samples collected from potable water supplies should not be filtered.

A detailed operation/procedural process for sampling water supplies can be found in the following references:

Wilde, F.D., Radtke, D.B., Gibs, Jacob, and Iwatsubo, R.T., eds., September 1999, Collection of Water Samples: U.S. Geological Survey Techniques of Water-Resources Investigations, book 9, chap. A4. <http://pubs.water.usgs.gov/twri9A4/>

U.S. EPA. 2001. Environmental Investigations Standards Operating Procedures and Quality Assurance Manual. U.S. Environmental Protection Agency. Region 4. Athens, Georgia. <http://www.epa.gov/region4/sesd/eisopqam/eisopqam.html>

Region 4
U.S. Environmental Protection Agency
Science and Ecosystem Support Division
Athens, Georgia

OPERATING PROCEDURE

Title: Groundwater Sampling

Effective Date: March 6, 2013

Number: SESDPROC-301-R3

Authors

Name: Jonathan Vail
Title: Environmental Scientist, Regional Expert

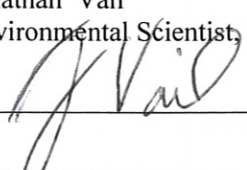
Signature: 

Date: 3/4/2013

Approvals

Name: Danny France
Title: Chief, Enforcement and Investigations Branch

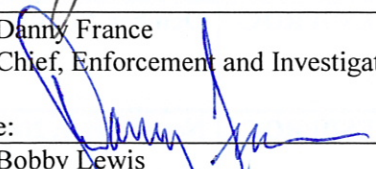
Signature: 

Date: 3/4/13

Name: Bobby Lewis
Title: Field Quality Manager, Science and Ecosystem Support Division

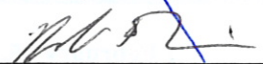
Signature: 

Date: 3/4/13

Revision History

The top row of this table shows the most recent changes to this controlled document. For previous revision history information, archived versions of this document are maintained by the SESD Document Control Coordinator on the SESD local area network (LAN).

History	Effective Date
<p>SESDPROC-301-R3, Groundwater Sampling, replaces SESDPROC-301-R2.</p> <p>General: Corrected any typographical, grammatical and/or editorial errors.</p> <p>Title Page: Changed author from Donald Hunter to Jonathan Vail. Changed Enforcement and Investigations Branch Chief from Archie Lee to Danny France.</p> <p>Revision History: Changes were made to reflect the current practice of only including the most recent changes in the revision history.</p> <p>Section 2.3: Item 4 was revised to reflect practice of using individual single-use preservative vials instead of preservatives prepared by ASB.</p>	March 6, 2013
<p>SESDPROC-301-R2, Groundwater Sampling, replaces SESDPROC-301-R1.</p>	October 28, 2011
<p>SESDPROC-301-R1, Groundwater Sampling, replaces SESDPROC-301-R0.</p>	November 1, 2007
<p>SESDPROC-301-R0, Groundwater Sampling, Original Issue</p>	February 05, 2007

TABLE OF CONTENTS

1	General Information	6
1.1	Purpose	6
1.2	Scope/Application	6
1.3	Documentation/Verification	6
1.4	References	6
1.5	General Precautions	8
1.5.1	Safety	8
1.5.2	Procedural Precautions	8
2	Special Sampling Considerations	10
2.1	Volatile Organic Compounds (VOC) Analysis	10
2.2	Special Precautions for Trace Contaminant Groundwater Sampling	10
2.3	Sample Handling and Preservation Requirements	11
2.4	Quality Control	12
2.5	Records	12
3	Groundwater Sampling Methods – Purging	13
3.1	General	13
3.2	Purging Methods and Strategies	13
3.2.1	Traditional Multiple Volume Purge	13
3.2.1.1	<i>Purging and Purge Adequacy</i>	13
3.2.1.1.1	<i>Purge Volume Determination</i>	13
3.2.1.1.2	<i>Chemical Parameter Stabilization Criteria</i>	15
3.2.1.1.3	<i>Purge Adequacy Considerations</i>	16
3.2.2	“Tubing-in-Screened-Interval” Method	16
3.2.2.1	<i>Purge Criteria</i>	17
3.2.2.1.1	<i>Placement of Pump Tubing or Intake</i>	17
3.2.2.1.2	<i>Conditions of Pumping</i>	17
3.2.2.1.3	<i>Stability of Chemical Parameters</i>	17

3.3	Equipment Considerations for Purging.....	17
3.3.1	Wells without Plumbing or In-Place Pumps	18
3.3.1.1	<i>Purging with Pumps</i>	18
3.3.1.1.1	<i>Peristaltic Pumps</i>	18
3.3.1.1.2	<i>Submersible Pumps</i>	19
3.3.1.2	<i>Purging with Bailers</i>	20
3.3.2	Wells with In-Place Plumbing	20
3.3.2.1	<i>Continuously Running Pumps</i>	20
3.3.2.2	<i>Intermittently or Infrequently Running Pumps</i>	21
3.3.3	Temporary Monitoring Wells.....	21
3.3.3.1	<i>General Considerations</i>	21
3.3.3.2	<i>Purging When Water Level Is Within Limit of Suction</i>	21
3.3.3.3	<i>Purging When Water Level Is Greater Than Limit of Suction</i>	22
3.3.3.4	<i>Considerations for Direct Push Groundwater Sampling</i>	22
3.4	Field Care of Purging Equipment	22
3.5	Investigation Derived Waste	23
4	Groundwater Sampling Methods – Sampling.....	24
4.1	General.....	24
4.2	Sampling Wells with In-Place Plumbing	24
4.3	Sampling Wells without Plumbing, Within the Limit of Suction.....	24
4.3.1	Equipment Available	24
4.3.1.1	<i>Peristaltic Pump, Direct from Pump Head Tubing</i>	24
4.3.1.2	<i>Peristaltic Pump/Vacuum Jug</i>	25
4.3.1.3	<i>RediFlo2® Electric Submersible Pump (with Teflon® Tubing)</i>	26
4.3.1.4	<i>Bailers</i>	26
4.4	Sampling Wells without Plumbing, Exceeding the Limit of Suction	26
4.5	Micro-Purge or No-Purge Sampling Procedures.....	27
4.5.1	Sampling with Pumps.....	27
4.5.2	HydraSleeves™	27
4.5.3	Passive Diffusion Bags	28
4.5.4	General Considerations for Micro-Purge or No-Purge Sampling	28

4.6	Sample Preservation	28
4.7	Special Sample Collection Procedures	29
4.7.1	Trace Organic Compounds and Metals.....	29
4.7.2	Order of Sampling with Respect to Analytes	29
4.7.3	Filtering.....	29
4.8	Specific Sampling Equipment Quality Assurance Techniques.....	31
4.9	Auxiliary Data Collection.....	31
4.9.1	Well Pumping Rate – Bucket/Stop Watch Method	31

1 General Information

1.1 Purpose

This document describes general and specific procedures, methods and considerations to be used and observed when collecting groundwater samples for field screening or laboratory analysis.

1.2 Scope/Application

The procedures contained in this document are to be used by field personnel when collecting and handling groundwater samples in the field. On the occasion that SESD field personnel determine that any of the procedures described are either inappropriate, inadequate or impractical and that another procedure must be used to obtain a groundwater sample, the variant procedure will be documented in the field logbook, along with a description of the circumstances requiring its use. Mention of trade names or commercial products in this operating procedure does not constitute endorsement or recommendation for use.

1.3 Documentation/Verification

This procedure was prepared by persons deemed technically competent by SESD management, based on their knowledge, skills and abilities and has been tested in practice and reviewed in print by a subject matter expert. The official copy of this procedure resides on the SESD Local Area Network (LAN). The Document Control Coordinator (DCC) is responsible for ensuring the most recent version of the procedure is placed on the LAN and for maintaining records of review conducted prior to its issuance.

1.4 References

Columbia Analytical Services, Lab Science News, Passive Diffusion Devices & Polyethylene Diffusion Bag (PDB) Samplers.

International Air Transport Authority (IATA). Dangerous Goods Regulations, Most Recent Version

Puls, Robert W., and Michael J. Barcelona. 1989. Filtration of Ground Water Samples for Metals Analysis. Hazardous Waste and Hazardous Materials 6(4), pp.385-393.

Puls, Robert W., Don A. Clark, and Bert Bledsoe. 1992. Metals in Ground Water: Sampling Artifacts and Reproducibility. Hazardous Waste and Hazardous Materials 9(2), pp. 149-162.

SESD Guidance Document, Design and Installation of Monitoring Wells, SESDGUID-001, Most Recent Version

SESD Operating Procedure for Control of Records, SESDPROC-002, Most Recent Version

SESD Operating Procedure for Sample and Evidence Management, SESDPROC-005, Most Recent Version

SESD Operating Procedure for Logbooks, SESDPROC-010, Most Recent Version

SESD Operating Procedure for Field Sampling Quality Control, SESDPROC-011, Most Recent Version

SESD Operating Procedure for Field pH Measurement, SESDPROC-100, Most Recent Version

SESD Operating Procedure for Field Specific Conductance Measurement, SESDPROC-101, Most Recent Version

SESD Operating Procedure for Field Temperature Measurement, SESDPROC-102, Most Recent Version

SESD Operating Procedure for Field Turbidity Measurement, SESDPROC-103, Most Recent Version

SESD Operating Procedure for Groundwater Level and Well Depth Measurement, SESDPROC-105, Most Recent Version

SESD Operating Procedure for Management of Investigation Derived Waste, SESDPROC-202, Most Recent Version

SESD Operating Procedure for Pump Operation, SESDPROC-203, Most Recent Version

SESD Operating Procedure for Field Equipment Cleaning and Decontamination, SESDPROC-205, Most Recent Version

SESD Operating Procedure for Field Equipment Cleaning and Decontamination at the FEC, SESDPROC-206, Most Recent Version

SESD Operating Procedure for Potable Water Supply Sampling, SESDPROC-305, Most Recent Version

The Interstate Technology & Regulatory Council, Technology Overview of Passive Sampler Technologies, Prepared by The Interstate Technology & Regulatory Council Diffusion Sampler Team, March 2006.

United States Environmental Protection Agency (US EPA). 1975. Handbook for Evaluating Water Bacteriological Laboratories. Office of Research and Development (ORD), Municipal Environmental Research Laboratory, Cincinnati, Ohio.

US EPA. 1977. Sampling for Organic Chemicals and Microorganisms in the Subsurface. EPA-600/2-77/176.

US EPA. 1978. Microbiological Methods for Monitoring the Environment, Water and Wastes. ORD, Municipal Environmental Research Laboratory, Cincinnati, Ohio.

US EPA. 1981. "Final Regulation Package for Compliance with DOT Regulations in the Shipment of Environmental Laboratory Samples," Memo from David Weitzman, Work Group Chairman, Office of Occupational Health and Safety (PM-273), April 13, 1981.

US EPA. 1995. Ground Water Sampling - A Workshop Summary. Proceedings from the Dallas, Texas November 30 – December 2, 1993 Workshop. ORD, Robert S. Kerr Environmental Research Laboratory. EPA/600/R-94/205, January 1995.

US EPA. Analytical Support Branch Laboratory Operations and Quality Assurance Manual. Region 4 SESD, Athens, GA, Most Recent Version

US EPA. Safety, Health and Environmental Management Program Procedures and Policy Manual. Region 4 SESD, Athens, GA, Most Recent Version

1.5 General Precautions

1.5.1 Safety

Proper safety precautions must be observed when collecting groundwater samples. Refer to the SESD Safety, Health and Environmental Management Program (SHEMP) Procedures and Policy Manual and any pertinent site-specific Health and Safety Plans (HASPs) for guidelines on safety precautions. These guidelines should be used to complement the judgment of an experienced professional. Address chemicals that pose specific toxicity or safety concerns and follow any other relevant requirements, as appropriate.

1.5.2 Procedural Precautions

The following precautions should be considered when collecting groundwater samples.

- Special care must be taken not to contaminate samples. This includes storing samples in a secure location to preclude conditions which could alter the properties of the sample. Samples shall be custody sealed during long-term storage or shipment.
- Always sample from the anticipated cleanest, i.e., least contaminated location, to the most contaminated location. This minimizes the opportunity for cross-contamination to occur during sampling.
- Collected samples must remain in the custody of the sampler or sample custodian until the samples are relinquished to another party.

- If samples are transported by the sampler, they will remain under his/her custody or be secured until they are relinquished.
- Shipped samples shall conform to all U.S. Department of Transportation (DOT) rules of shipment found in Title 49 of the Code of Federal Regulations (49 CFR parts 171 to 179), and/or International Air Transportation Association (IATA) hazardous materials shipping requirements found in the current edition of IATA's Dangerous Goods Regulations.
- Documentation of field sampling is done in a bound logbook.
- Chain-of-custody documents shall be filled out and remain with the samples until custody is relinquished.
- All shipping documents, such as air bills, bills of lading, etc., shall be retained by the project leader and placed in the project files.

2 Special Sampling Considerations

2.1 Volatile Organic Compounds (VOC) Analysis

Groundwater samples for VOC analysis must be collected in 40 ml glass vials with Teflon® septa. The vial may be either preserved with concentrated hydrochloric acid or they may be unpreserved. Preserved samples have a two-week holding time, whereas unpreserved samples have only a seven-day holding time. In the great majority of cases, the preserved vials are used to take advantage of the extended holding time. In some situations, however, it may be necessary to use the unpreserved vials. For example, if the groundwater has a high amount of dissolved limestone, i.e., is highly calcareous, there will most likely be an effervescent reaction between the hydrochloric acid and the water, producing large numbers of fine bubbles. This will render the sample unacceptable. In this case, unpreserved vials should be used and arrangements must be confirmed with the laboratory to ensure that they can accept the unpreserved vials and meet the shorter sample holding times.

The samples should be collected with as little agitation or disturbance as possible. The vial should be filled so that there is a meniscus at the top of the vial and absolutely no bubbles or headspace should be present in the vial after it is capped. After the cap is securely tightened, the vial should be inverted and tapped on the palm of one hand to see if any undetected bubbles are dislodged. If a bubble or bubbles are present, the vial should be topped off using a minimal amount of sample to re-establish the meniscus. Care should be taken not to flush any preservative out of the vial during topping off. If, after topping off and capping the vial, bubbles are still present, a new vial should be obtained and the sample re-collected.

Samples for VOC analysis must be collected using either stainless steel or Teflon® equipment, such as:

- Bailers must be constructed of stainless steel or Teflon®
- RediFlo2® submersible pumps used for sampling should be equipped with Teflon® sample delivery tubing
- Peristaltic pump/vacuum jug assemblies should be outfitted with Teflon® tubing from the water column to the transfer cap, which should also be constructed of Teflon®

2.2 Special Precautions for Trace Contaminant Groundwater Sampling

- A clean pair of new, non-powdered, disposable gloves will be worn each time a different location is sampled and the gloves should be donned immediately prior to sampling. The gloves should not come in contact with the media being sampled and should be changed any time during sample collection when their cleanliness is compromised.
- Sample containers for samples suspected of containing high concentrations of contaminants shall be stored separately.

- Sample collection activities shall proceed progressively from the least suspected contaminated area to the most suspected contaminated area if sampling devices are to be reused. Samples of waste or highly contaminated media must not be placed in the same ice chest as environmental (i.e., containing low contaminant levels) or background samples.
- If possible, one member of the field sampling team should take all the notes and photographs, fill out tags, etc., while the other members collect the samples.
- Clean plastic sheeting will be placed on the ground at each sample location to prevent or minimize contaminating sampling equipment by accidental contact with the ground surface.
- Samplers must use new, verified certified-clean disposable or non-disposable equipment cleaned according to procedures contained in SESD Operating Procedure for Field Equipment Cleaning and Decontamination (SESDPROC-205) or SESD Operating Procedure for Field Equipment Cleaning and Decontamination at the FEC (SESDPROC-206) for collection of samples for trace metals or organic compound analyses.

2.3 Sample Handling and Preservation Requirements

1. Groundwater samples will typically be collected from the discharge line of a pump or from a bailer, either from the pour stream of an up-turned bailer or from the stream from a bottom-emptying device. Efforts should be made to reduce the flow from either the pump discharge line or the bailer during sample collection to minimize sample agitation.
2. During sample collection, make sure that the pump discharge line or the bailer does not contact the sample container.
3. Place the sample into appropriate, labeled containers. Samples collected for VOC, acidity and alkalinity analysis must not have any headspace. All other sample containers must be filled with an allowance for ullage.
4. All samples requiring preservation must be preserved as soon as practically possible, ideally immediately at the time of sample collection. If preserved VOC vials are used, these will be preserved with concentrated hydrochloric acid by ASB personnel prior to departure for the field investigation. For all other chemical preservatives, SESD will use the appropriate chemical preservative generally stored in an individual single-use vial as described in the SESD Operating Procedure for Field Sampling Quality Control (SESDPROC-011). The adequacy of sample preservation will be checked after the addition of the preservative for all samples except for the samples collected for VOC analysis. If additional preservative is needed, it should be added to achieve adequate preservation. Preservation requirements for groundwater samples are found in the USEPA Region 4 Analytical Support Branch Laboratory Operations and Quality Assurance Manual (ASBLOQAM).

2.4 Quality Control

If possible, a control sample should be collected from a location not affected by the possible contaminants of concern and submitted with the other samples. This control sample should be collected as close to the sampled area as possible and from the same water-bearing formation. Equipment blanks should be collected if equipment is field cleaned and re-used on-site or if necessary to document that low-level contaminants were not introduced by pumps, bailers or other sampling equipment.

2.5 Records

Information generated or obtained by SESD personnel will be organized and accounted for in accordance with SESD records management procedures found in SESD Operating Procedure for Control of Records, SESDPROC-002. Field notes, recorded in a bound field logbook, will be generated, as well as chain-of-custody documentation in accordance with SESD Operating Procedure for Logbooks, SESDPROC-010 and SESD Procedure for Sample and Evidence Management, SESDPROC-005.

3 Groundwater Sampling Methods – Purging

3.1 General

Purging is the process of removing stagnant water from a well, immediately prior to sampling, causing its replacement by groundwater from the adjacent formation that is representative of actual aquifer conditions. In order to determine when a well has been adequately purged, field investigators should monitor, at a minimum, the pH, specific conductance and turbidity of the groundwater removed during purging and, in the case of permanent monitoring wells, observe and record the volume of water removed.

There are several purging strategies that may be used, depending on specific conditions encountered for given well sampling situations. When a specific well is characterized, based on the field investigators experience and knowledge, as having fairly typical water levels, depths and purge volumes, as determined according to the procedures in Section 3.2.1, below, SESD will normally use the multiple volume purging procedures and equipment described in Sections 3.2.1 and 3.3 of this procedure for purging the well.

When the traditional multiple volume purge method is considered and it is determined that excessive quantities of IDW would be generated using this method, it may be appropriate, under very limited and specific circumstances, to use an alternate method that reduces the time and amount of purge water to be removed prior to sampling the well. The field project leader will select the alternate method only after careful consideration of the conditions presented by the well and the impact these conditions have on all aspects of the sampling event (time required to sample, quantities of IDW requiring management, etc.).

The alternate purge procedures or sampling strategies available are the “Tubing-in-Screened Interval” method and the MicroPurge or No-Purge methods. These are described and discussed in Sections 3.2.2 and 4.5 of this operating procedure, respectively.

3.2 Purging Methods and Strategies

3.2.1 Traditional Multiple Volume Purge

3.2.1.1 Purging and Purge Adequacy

3.2.1.1.1 Purge Volume Determination

Prior to initiating the purge, the amount of water standing in the water column (water inside the well riser and screen) should be determined, if possible. To do this, the diameter of the well should be determined and the water level and total depth of the well should be measured and recorded. Specific methodology for obtaining these measurements is found in SESD Operating Procedure for Groundwater Level and Well Depth Measurement (SESDPROC-105).

Once this information is obtained, the volume of water to be purged can be determined using one of several methods. One is the equation:

$$V = 0.041 d^2h$$

Where: h = depth of water in feet

d = diameter of well in inches

V = volume of water in gallons

Alternatively, the volume of standing water in the well and the volume of three water columns may be determined using a casing volume per foot factor for the appropriate diameter well, similar to that in Table 3.2.1. The water level is subtracted from the total depth, providing the length of the water column. This length is multiplied by the appropriate factor in the Table 3.2.1, corresponding to either the single well volume or the triple well volume, to determine both the single well volume and triple well volumes, in gallons, for the well in question. Other acceptable methods include the use of nomographs or other equations or formulae.

TABLE 3.2.1: WELL CASING DIAMETER VOLUME FACTORS

Casing Diameter (inches)	Gallons/ft, One Water Column	Gallons/ft, Three Water Columns
1	0.04	0.12
2	0.16	0.48
3	0.37	1.11
4	0.65	1.98
5	1.02	3.06
6	1.47	4.41
7	1.99	5.97
8	2.61	7.83
9	3.30	9.90
10	4.08	12.24
11	4.93	14.79
12	5.87	17.61

With respect to volume, an adequate purge is normally achieved when three to five well volumes have been removed. The field notes should reflect the single well volume calculations or determinations, according to one of the above methods, and a reference to the appropriate

multiplication of that volume, i.e., a minimum three well volumes, clearly identified as a purge volume goal.

3.2.1.1.2 Chemical Parameter Stabilization Criteria

With respect to the ground water chemistry, an adequate purge is achieved when the pH and specific conductance of the ground water have stabilized and the turbidity has either stabilized or is below 10 Nephelometric Turbidity Units (NTUs) (twice the Primary Drinking Water Standard of 5 NTUs). Although 10 NTUs is normally considered the minimum goal for most ground water sampling objectives, lower turbidity has been shown to be easily achievable in most situations and reasonable attempts should be made to achieve these lower levels. (Note: Because groundwater temperature is subject to rapid changes when collected for parameter measurement, its usefulness is subject to question for the purpose of determining parameter stability. As such, it has been removed from the list of parameters used for stability determination. Even though temperature is not used to determine stability during well purging, it is still advisable to record the sample temperature, along with the other groundwater chemistry parameters during well purging, as it may be needed to interpret other chemical parameter results in some situations.)

Stabilization occurs when, for at least three consecutive measurements, the pH remains constant within 0.1 Standard Unit (SU) and specific conductance varies no more than approximately 5 percent. Other parameters, such as dissolved oxygen (DO), may also be used as a purge adequacy parameter. Normal goals for DO are 0.2 mg/L or 10% saturation, whichever is greater. DO measurements must be conducted using either a flow-through cell or an over-topping cell to minimize or reduce any oxygenation of the sample during measurement. Oxidation Reduction Potential (ORP) should not be used as a purge stabilization parameter but may be measured during purging to obtain the measurement of record for ORP for the sampling event.

There are no set criteria for establishing how many total sets of measurements are adequate to document stability of parameters. If the calculated purge volume is small, the measurements should be taken frequently enough to provide a sufficient number of measurements to evaluate stability. If the purge volume is large, measurements taken every 15 minutes, for example, may be sufficient. See the SESD Operating Procedures for Field pH Measurement (SESDPROC-100), Field Specific Conductance Measurement (SESDPROC-101), Field Temperature Measurement (SESDPROC-102), Field Turbidity Measurement (SESDPROC-103), Field Measurement of Dissolved Oxygen (SESDPROC-106) and Field Measurement of Oxidation-Reduction Potential (SESDPROC-113) for procedures for conducting these measurements.

If, after three well volumes have been removed, the chemical parameters have not stabilized according to the above criteria, additional well volumes (up to five well volumes), should be removed. If the parameters have not stabilized within five volumes, it is at the discretion of the project leader whether or not to collect a sample or to continue purging. If, after five well volumes, pH and conductivity have stabilized and the turbidity is still decreasing and approaching an acceptable level, additional purging should be considered to obtain the best sample possible, with respect to turbidity. The conditions of sampling should be noted in the field log.

3.2.1.1.3 Purge Adequacy Considerations

In some situations, even with slow purge rates, a well may be pumped or bailed dry (evacuated). In these situations, this generally constitutes an adequate purge and the well can be sampled following sufficient recovery (enough volume to allow filling of all sample containers). ***It is not necessary that the well be evacuated three times before it is sampled.*** The pH, specific conductance, temperature, and turbidity should be measured and recorded, during collection of the sample from the recovered volume, as the measurements of record for the sampling event.

For wells with slow recovery, attempts should be made to avoid purging them to dryness. This can be accomplished, for example, by slowing the purge rate. As water enters a well that has been purged to dryness, it may cascade down the sand pack and/or the well screen, stripping volatile organic constituents that may be present and/or introducing soil fines into the water column.

It is particularly important that wells be sampled as soon as possible after purging. If adequate volume is available immediately upon completion of purging, the well must be sampled immediately. If not, sampling should occur as soon as adequate volume has recovered. If possible, sampling of wells which have a slow recovery should be scheduled so that they can be purged and sampled in the same day, after adequate volume has recovered. Wells of this type should, unless it is unavoidable, not be purged at the end of one day and sampled the following day.

3.2.2 “Tubing-in-Screened-Interval” Method

The “Tubing-in-Screen” method, sometimes referred to as the “Low Flow” method, is used primarily when calculated purge volumes for the traditional purging method are excessive and present issues related to timely completion of the project and/or management of investigation derived waste.

3.2.2.1 Purge Criteria

3.2.2.1.1 Placement of Pump Tubing or Intake

The peristaltic pump tubing or intake point of the submersible pump is placed in the approximate mid-portion of the screened interval of the well. By definition, this method cannot be applied for purging with a bailer.

3.2.2.1.2 Conditions of Pumping

Prior to initiation of pumping, a properly decontaminated well sounder should be lowered into the well being sampled to monitor the static water level prior to and during the purging process. Ideally, there should be only a slight and stable drawdown of the water column after pumping begins. If this condition cannot be met, then one of the other methods should be employed.

3.2.2.1.3 Stability of Chemical Parameters

As with the traditional purging method described in Section 3.2.1, it is important that all chemical parameters be stable as defined in Section 3.2.1.1 prior to sampling.

3.3 Equipment Considerations for Purging

Monitoring well purging is accomplished by using in-place plumbing and dedicated pumps or by using portable pumps/equipment when dedicated systems are not present. The equipment utilized by Branch personnel will usually consist of peristaltic pumps and variable speed electric submersible pumps, but may also include bladder pumps or inertial pumps. The pump of choice is usually a function of the well diameter, the depth to water, the depth of the well and the amount of water that is to be removed during purging. Whenever the head difference between the sampling location and the water level is less than the limit of suction and the volume to be removed is reasonably small, a peristaltic pump should be used for purging. For wells where the water level is below the limit of suction (approximately 25' to 30', and/or where there is a large volume of water to be purged), the variable speed electric submersible pump would be the pump of choice. SESD Operating Procedure for Pump Operation (SESDPROC-203) contains the use and operating instructions for all pumps commonly used during SESD ground water investigations.

Bailers may also be used for purging in appropriate situations, however, their use is discouraged. Bailers tend to disturb any sediment that may be present in the well, creating or increasing sample turbidity. Bailers, if improperly used, may also strip volatile organic compounds from the water column being sampled. If a bailer is used, it should be a closed-top Teflon® bailer.

3.3.1 Wells Without Plumbing or In-Place Pumps

For permanent monitoring wells, the depth to water (water level) and depth of the well (total depth) should be determined before purging. Caution should be exercised during this procedure to prevent cross-contamination between wells. This is a critical concern when samples for trace organic compounds or metals analyses are collected. See SESD Operating Procedure for Field Equipment Cleaning and Decontamination (SESDPROC-205) for cleaning procedures for well sounders. After cleaning, the well sounding device should be protected to keep it clean until its next use.

3.3.1.1 Purging with Pumps

3.3.1.1.1 Peristaltic Pumps

The following step-by-step procedures describe the process of purging with a peristaltic pump:

1. Cut a length of standard-cleaned (SESD Operating Procedure for Field Equipment Cleaning and Decontamination at the FEC (SESDPROC-206)) Teflon® tubing, equal to the well depth plus an additional five to ten feet. Enough tubing is needed to run from the ground surface up to the top of the well casing and back down to the bottom of the well. This will allow for operation of the pump at all possible water level conditions in the well.
2. Place one end of the tubing into the vacuum side of the peristaltic pump head. Proper sizing of the Teflon® and Silastic® or Tygon® tubing should allow for a snug fit of the Teflon® tubing inside the flexible tubing mounted in the pump head.
3. Run a short section of tubing (does not have to be Teflon®) from the discharge side of the pump head to a graduated bucket.
4. Place the free end of the Teflon® tubing into the well until the end of the tubing is just below the surface of the water column.
5. Secure the Teflon® tubing to the well casing or other secure object using electrician's tape or other suitable means. This will prevent the tubing from being lost in the well should the tubing detach from the pump head.
6. Turn on the pump to produce a vacuum on the well side of the pump head and begin the purge. Observe pump direction to ensure that a vacuum is being applied to the purge line. If the purge line is being pressurized, either switch the tubing at the pump head or reverse the polarity of the cables on the pump or on the battery.

7. If the pumping rate exceeds the recovery rate of the well, continue to lower the tubing into the well, as needed, until the drawdown stabilizes or the well is evacuated to dryness. If the pump is a variable speed peristaltic pump, and the water level in the well is being drawn down, reduce the speed of the pump in an attempt to stabilize the drawdown. If the well can be purged without evacuating the well to dryness, a sample with greater integrity can be obtained.
8. For wells which are not evacuated to dryness, particularly those with recovery rates equal to or very nearly equal to the purge rate, there may not be a complete exchange and removal of stagnant water in that portion of the water column above the tubing intake. For this reason, it is important that the tubing intake be placed in the very uppermost portion of the water column while purging. Standard field measurements should frequently be taken during this process to verify adequacy of the purge and readiness for sampling, as described in Section 3.

3.3.1.1.2 Submersible Pumps

When a submersible pump is used for well purging, the pump itself is lowered into the water column. The pump must be cleaned as specified in SESD Operating Procedure for Field Equipment Cleaning and Decontamination (SESDPROC-205).

The pump/hose assembly used in purging should be lowered into the top of the standing water column and not deep into the column. This is done so that the purging will "pull" water from the formation into the screened area of the well and up through the casing so that the entire static volume can be removed. If the pump is placed deep into the water column, the water above the pump may not be removed, and the subsequent samples, particularly if collected with a bailer, may not be representative of the aquifer conditions. It is recommended that the pump not be lowered more than three to five feet into the water column. If the recovery rate of the well is faster than the pump rate and no observable draw down occurs, the pump should be raised until the intake is within one foot of the top of the water column for the duration of purging. If the pump rate exceeds the recovery rate of the well, the pump will have to be lowered, as needed, to accommodate the drawdown. After the pump is removed from the well, the hose and the pump should be cleaned as outlined in SESD Operating Procedure for Field Equipment Cleaning and Decontamination (SESDPROC-205).

3.3.1.2 Purging with Bailers

Standard-cleaned (SESD Operating Procedure for Field Equipment Cleaning and Decontamination (SESDPROC-205) or SESD Operating Procedure for Field Equipment Cleaning and Decontamination at the FEC (SESDPROC-206)), closed top Teflon® bailers with Teflon® coated stainless steel leaders and new nylon rope are lowered into the top of the water column, allowed to fill, and removed. It is critical that bailers be slowly and gently immersed into the top of the water column, particularly during final stages of purging, to minimize turbidity and disturbance of volatile organic constituents. The use of bailers for purging and sampling is discouraged because the correct technique is highly operator dependent and improper use may result in an unrepresentative sample.

3.3.2 Wells With In-Place Plumbing

Wells with in-place plumbing are commonly found at municipal water treatment plants, industrial water supplies, private residences, etc. Many permanent monitoring wells at active facilities are also equipped with dedicated, in-place pumps. The objective of purging wells with in-place pumps is the same as with monitoring wells without in-place pumps, i.e., to ultimately collect a ground water sample representative of aquifer conditions. Among the types of wells identified in this section, two different approaches are necessary.

A permanent monitoring well with an in-place pump should, in all respects, be treated like a monitoring well without a pump. One limitation is that in most cases the in-place pump is “hard” mounted, that is, the pump is suspended in the well at a pre-selected depth and cannot be moved up or down during purging and sampling. In these cases, well volumes are calculated, parameters are measured and the well is sampled from the pump discharge, after volume removal and parameter conditions have been met.

In the case of the other types of wells, i.e., municipal, industrial and residential supply wells, however, not enough is generally known about the construction aspects of the wells to apply the same criteria as used for monitoring wells, i.e., 3 to 5 well volumes. The volume to be purged in these situations, therefore, depends on several factors: whether the pumps are running continuously or intermittently and whether or not any storage/pressure tanks are located between the sampling point and the pump. The following considerations and procedures should be followed when purging wells with in-place plumbing under the conditions described.

3.3.2.1 Continuously Running Pumps

If the pump runs more or less continuously, no purge (other than opening a valve and allowing it to flush for a few minutes) is necessary. If a storage tank is present, a spigot, valve or other sampling point should be located between the

pump and the storage tank. If not, locate the valve closest to the tank. Measurements of pH, specific conductance, temperature, and turbidity are recorded at the time of sampling.

3.3.2.2 Intermittently or Infrequently Running Pumps

If the pump runs intermittently or infrequently, best judgment should be utilized to remove enough water from the plumbing to flush standing water from the piping and any storage tanks that might be present. Generally, under these conditions, 15 to 30 minutes will be adequate. Measurements of pH, specific conductance, temperature and turbidity should be made and recorded at intervals during the purge and the final measurements made at the time of sampling should be considered the measurements of record for the event.

3.3.3 Temporary Monitoring Wells

3.3.3.1 General Considerations

Procedures used to purge temporary ground water monitoring wells differ from permanent wells because temporary wells are installed for immediate sample acquisition. Wells of this type may include standard well screen and riser placed in boreholes created by hand augering, power augering, or by drilling. They may also consist of a rigid rod and screen that is pushed, driven, or hammered into place to the desired sampling interval, such as a direct push Wellpoint®, a Geoprobe® Screen Point 15/16 sampler or a Hydropunch® sampler. As such, the efforts to remove several volumes of water to replace stagnant water do not necessarily apply because stagnant water is not present. It is important to note, however, that the longer a temporary well is in place and not sampled, the more stagnant the water column becomes and the more appropriate it becomes to apply, to the extent possible, standard permanent monitoring well purging criteria to it to re-achieve aquifer conditions.

In cases where the temporary well is to be sampled immediately after installation, purging is conducted primarily to mitigate the impacts of installation. In most cases, temporary well installation procedures disturb the existing aquifer conditions, resulting primarily in increased turbidity. Therefore, the goal of purging is to reduce the turbidity and remove the volume of water in the area directly impacted by the installation procedure. Low turbidity conditions in these types of wells that are completed within the limit of suction are typically and routinely achieved by the use of low-flow/low stress purging techniques using variable speed peristaltic pumps.

3.3.3.2 Purging When Water Level Is Within Limit of Suction

In situations where the elevation of the top of the water column is within the limit of suction (no greater than about 25 feet head difference between the pump and the water level), a variable speed peristaltic pump may be used to purge

temporary wells. Enough tubing is deployed to reach the bottom of the temporary well screen. At the onset of purging, the tubing is slowly lowered to the bottom of the screen and is used to remove any formation material which may have entered the well screen during installation. This is critical to ensuring rapid achievement of low turbidity conditions. After the formation material is removed from the bottom of the screen, the tubing is slowly raised through the water column to near the top of the column. The tubing can be held at this level to determine if the pump rate is drawing down the water level in the well. If the water level remains the same, secure the tubing at the surface to maintain this pumping level.

If drawdown is observed on initiation of pumping, reduce the pump speed and attempt to match the drawdown of the well. Sustained pumping at these slow rates will usually result in a relatively clear, low turbidity sample. If the drawdown stabilizes, maintain that level, however, if it continues to lower, "chase" the water column until the well is evacuated. In this case, the recovered water column may be relatively free of turbidity and can be sampled. It may take several episodes of recovery to provide enough volume for a complete sample.

3.3.3.3 Purging When Water Level Is Greater Than Limit of Suction

In situations where the elevation of the water table is greater than the limit of suction, peristaltic pumps cannot be used to purge temporary wells. If the temporary well is a ScreenPoint15® sampler with small diameter probe rod riser, the only practical choices for water removal are a small diameter bailer, a small diameter bladder pump or an inertial pump. If the well is to be used strictly for VOC screening, it may be acceptable to use the bailer to bail as much sediment from the well as possible prior to sampling. If metals are the analytes of concern, the bladder pump is the best choice for lowering the turbidity of the water column prior to sampling, followed next by the inertial pump. For larger diameter temporary wells, two-inch diameter or greater, bailers and the Grundfos® RediFlo2 may be used although excessive silt or other "fines" may present problems with the operation of the pump.

3.3.3.4 Considerations for Direct Push Groundwater Sampling

With many of the direct push sampling techniques, purging is either not practical or possible, therefore, no purging is conducted. The sampling device is simply pushed or driven to the desired depth and opened and the sample is collected and retrieved. As a result, some samples collected in this way may not be satisfactory or acceptable for certain analyses, i.e., the subject procedure may yield a turbid sample that is not appropriate for metals analyses.

3.4 Field Care of Purging Equipment

New plastic sheeting should be placed on the ground surface around the well casing to prevent contamination of the pumps, hoses, ropes, etc., in the event they accidentally

come into contact with the ground surface or, for some reason, they need to be placed on the ground during the purging event. It is preferable that hoses used in purging that come into contact with the ground water be kept on a spool or contained in a large wash tub lined with plastic sheeting, both during transportation and during field use, to further minimize contamination by the transporting vehicle or the ground surface.

Careful consideration shall be given to using submersible pumps to purge wells which are excessively contaminated with oily compounds, because it may be difficult to adequately decontaminate severely contaminated pumps under field conditions. When wells of this type are encountered, alternative purging methods, such as bailers, should be considered.

3.5 Investigation Derived Waste

Purging generates quantities of purge water or investigation derived waste (IDW), the disposition of which must be considered. See SESD Operating Procedure for Management of Investigation Derived Waste (SESDPROC-202) for guidance on management or disposal of this waste.

4 Groundwater Sampling Methods – Sampling

4.1 General

Sampling is the process of obtaining, containerizing, and preserving (if required) a ground water sample after the purging process is complete. Non-dedicated pumps for sample collection generally should not be used. Many pumps are made of materials such as brass, plastic, rubber, or other elastomeric products which may cause chemical interferences with the sample. Their principle of operation may also render them unacceptable as a sample collection device. It is recognized that there are situations, such as industrial or municipal supply wells or private residential wells, where a well may be equipped with a dedicated pump from which a sample would not normally be collected. Discretion should always be used in obtaining a sample.

4.2 Sampling Wells With In-Place Plumbing

Samples should be collected following purging from a valve or cold water tap as near to the well as possible, preferably prior to any storage/pressure tanks or physical/chemical treatment system that might be present. Remove any hose that may be present before sample collection and reduce the flow to a low level to minimize sample disturbance, particularly with respect to volatile organic constituents. Samples should be collected directly into the appropriate containers as specified in the ASBLOQAM. It may be necessary to use a secondary container, such as a clean 8 oz. or similar size sample jar or a stainless steel scoop, to obtain and transfer samples from spigots with low ground clearance. Also, refer to the discussion in the SESD Operating Procedure for Potable Water Supply Sampling (SESDPROC-305), Sec. 4.2, Potable Water Samples Collected from Wells with In-Place Plumbing. Potable well measurements for pH, specific conductance and turbidity and possibly temperature, if warranted, should be recorded at the time of sample collection.

4.3 Sampling Wells Without Plumbing, Within the Limit of Suction

4.3.1 Equipment Available

The pump of choice for sampling ground water within the limit of suction is the variable-speed peristaltic pump. Its use is described in the following sections. Other acceptable alternatives that may be used under these conditions are the RediFlo2® electric submersible pump (with Teflon® tubing) and a closed-top Teflon® bailer.

4.3.1.1 Peristaltic Pump, Direct from Pump Head Tubing

Samples for some constituents, primarily inorganic analytes such as metals and cyanide, may be collected directly from the pump head tubing. This method is acceptable under the following conditions:

- The pump head tubing must be changed between sampling locations;

- The pump head tubing must be either be certified clean according to SESD's internal quality control program described in Section 3.2 of the SESD Operating Procedure for Field Sampling Quality Control (SESDPROC-011) or
- An equipment rinsate blank is collected by pumping de-ionized water through a piece of the tubing.

4.3.1.2 Peristaltic Pump/Vacuum jug

It is not acceptable to collect samples for organic compound analyses through the flexible tubing used in the pump head. When collecting samples for organic compound analyses it is necessary to use a vacuum container, placed between the pump and the well for sample collection. The following step-by-step procedures describe the process of sampling with a peristaltic pump and vacuum jug (see note following these procedures for collection of VOC samples):

1. Disconnect the purge tubing from the pump. Make sure the tubing is securely attached to the protective casing or other secure object.
2. Insert the tubing into one of the ferrule nut fittings of a Teflon® vacuum container transfer cap assembly.
3. Place a suitable length of Teflon® tubing between the remaining transfer cap assembly ferrule nut fitting and the vacuum side of the flexible tubing in the peristaltic pump head. Securely hand-tighten both fittings.
4. Turn the pump on. Water should begin to collect in the transfer container (typically a 1-liter sample container) within a few minutes. If water does not begin to flow into the container within several minutes, check the transfer cap fittings and make sure the assembly is tightly attached to the container. It may be necessary to tighten the ferrule nuts with a wrench or pliers to achieve a vacuum in the system, particularly when approaching the maximum head difference between the pump and water table (limit of suction).
5. When the transfer container is nearly full, turn off the pump, remove the transfer cap assembly, and pour the sample into the appropriate containers. Because the 1-liter containers used by the Branch are rinsed with nitric acid during cleaning, they cannot be used for collecting samples to be analyzed for nitrogen sensitive parameters.
6. If additional sample volume is needed, replace the transfer cap assembly, turn the pump on, and collect additional volume. The use of Teflon® valves or ball check devices to retain the water column in the sample delivery tubing during the transfer phase, when large volumes of sample are required, is acceptable. These devices, however, must be constructed so that they may be completely disassembled and cleaned according to the procedures in SESD

Operating Procedure for Field Equipment Cleaning and Decontamination (SESDPROC-205).

7. When sampling is completed, all Teflon® tubing should be discarded.

NOTE: Samples for volatile organic compound analyses cannot be collected using this method. If samples for VOC analyses are required, they must be collected with a Teflon® or stainless steel bailer or by other approved methods, such as the “soda straw” method. The “soda straw” method involves allowing the tubing to fill, by either lowering it into the water column (A) or by filling it via suction applied by the pump head (B). If method (A) is used, the tubing is removed from the well after filling and the captured sample is allowed to drain into the sample vial. If method (B) is used, after running the pump and filling the tubing with sample, the pump speed is reduced and the direction reversed to push the sample out of the tubing into the vials. Avoid completely emptying the tubing when filling the sample vials when using method (B) to prevent introducing water that was in contact with the flexible pump head tubing. Either method is repeated, as necessary, until all vials are filled.

4.3.1.3 RediFlo2® Electric Submersible Pump (with Teflon® Tubing)

After purging has been accomplished with RediFlo2® electric submersible pump, the sample may be obtained directly from the pump discharge, provided that Teflon® tubing was used for the sample delivery line. The discharge rate of the pump should be reduced during volatile organic compound sample collection to minimize sample disturbance. Note, if the RediFlo2® electric submersible pump is used for sampling, the pump must undergo a full external and internal cleaning. In addition, pump rinsate blanks must be collected, at the appropriate frequency, to demonstrate that the pump has been adequately cleaned between wells.

4.3.1.4 Bailers

New bailer rope should be attached to the bailer via a Teflon® coated stainless steel wire. (If a bailer was used to purge the well, it may also be used to sample the well and new bailer rope is not required between purging and sampling). The bailer should be gently immersed in the top of the water column until just filled. At this point, the bailer should be slowly removed and the contents emptied into the appropriate sample containers.

4.4 Sampling Wells without Plumbing, Exceeding the Limit of Suction

All methods described previously in Section 4.3.2.1.3, RediFlo2® Electric Submersible Pumps, and Section 4.3.2.1.4, Bailers, are suitable sample methods where the water table is too deep to consider the use of a peristaltic pump for sampling.

4.5 Micro-Purge or No Purge Sampling Procedures

The Micro-Purge or No Purge sampling procedures are usually employed when it necessary to keep purge volumes to an absolute minimum. Among the Micro-Purge or No Purge procedures that might be employed are:

- Low pump rate sampling with peristaltic or submersible pumps (typical Micro-Purge sampling),
- HydraSleeve™ or
- Passive diffusion bag (PDB) sampling

The use of these procedures is acceptable only when the site hydrogeology is well understood, with respect to the hydraulic conductivity of geologic materials within the well screen interval. The underlying assumption, when employing these procedures, is that the formation in which the well is screened has a high hydraulic conductivity ($K > 10^{-5}$ cm/sec, for example), resulting in a state of equilibrium existing between the water standing in the screened interval and the formation water in which the well is screened. In this situation, the well is considered to be in a perpetually “purged” state and purging is not required.

These procedures are generally impractical for SESD to implement because of the general lack of hydrogeologic information for the sampled wells and the real necessity, in some cases, that the pumps be pre-deployed to overcome issues related to turbidity resulting from pump placement prior to sampling.

4.5.1 Sampling with Pumps

The peristaltic pump tubing or intake point of the submersible pump is placed in the approximate mid-portion of the screened interval of the well or other interval selected by the field team leader. If turbidity and its impact on metals analyses are a concern, a period of time sufficient should be allowed to mitigate effects of pump or tubing placement. After it has been determined that sampling may proceed, the pump is turned on and operated at a rate that does not cause significant drawdown of the water column, as measured using a water level sounder. During sampling, sufficient water to supply enough volume for the analytes of concern and the purge parameters is pumped. Purging should continue until purge parameters stabilize, generally three consecutive stable sets of readings, before samples are collected.

4.5.2 HydraSleeves™

HydraSleeves™ are grab sampling devices that are deployed in a closed configuration then opened in the desired interval for sample collection. The following is a summary of its operation:

1. Sampler placement - Reusable weight is attached and the HydraSleeve™ is lowered and placed at the desired position in the well screen. In-situ water pressure keeps the reed valve closed, preventing water from entering the sampler. Well is allowed to return to equilibrium.

2. Sample collection - The reed valve opens to allow filling when the sampler is moved upward faster than 1 foot per second, either in one continuous upward pull or by cycling the sampler up and down to sample a shorter interval. There is no change in water level, and only minimal agitation during collection.
3. Sample retrieval - When the flexible sleeve is full, the reed valve closes and the sampler can be recovered without entry of extraneous overlying fluids. Samples are removed by puncturing the sleeve with the pointed discharge tube and draining the contents into containers for sampling or field measurement.

4.5.3 Passive Diffusion Bags

Passive diffusion bag (PDB) samplers are bags comprised of low-density polyethylene (LDPE) plastic and containing analyte-free water, preferably with no headspace. The bags are deployed, with stainless steel weights, to the desired sample interval and are allowed to equilibrate with the water at the point of deployment in the well. A deployment period of a minimum of 14 days is recommended to ensure equilibration prior to removal.

After 14 days, the bags are opened with a puncture device or other cutting implement and the contents transferred to containers for sampling or field measurement.

4.5.4 General Considerations for Micro-Purge or No-Purge Sampling

When using the Micro-Purge method, it may be advisable to deploy the tubing or pump in advance of sample collection. Introducing the tubing or pump into the screened interval is likely to dislodge sediment and other fines that have settled or bridged on the well screen material and the gravel pack media behind the screen. If sampling is conducted immediately, turbidity issues may render this method impractical from a parameter stability standpoint.

HydraSleeves™ and PDBs must be evaluated for appropriateness for analytes of concern.

4.6 Sample Preservation

After sample collection, all samples requiring preservation must be preserved as soon as practical. Consult the ASBLOQAM for the correct preservative for the particular analytes of interest. All samples preserved using a pH adjustment (except VOCs) must be checked, using pH strips, to ensure that they were adequately preserved. This is done by pouring a small volume of sample over the strip. Do not place the strip in the sample. Samples requiring reduced temperature storage should be placed on ice immediately.

4.7 Special Sample Collection Procedures

4.7.1 Trace Organic Compounds and Metals

Special sample handling procedures should be instituted when trace contaminant samples are being collected. All sampling equipment, including pumps, bailers, water level measurement equipment, etc., which comes into contact with the water in the well must be cleaned in accordance with the cleaning procedures described in the SESD Operating Procedure for Field Equipment Cleaning and Decontamination (SESDPROC-205) or SESD Operating Procedure for Field Equipment Cleaning and Decontamination at the FEC (SESDPROC-206). Pumps should not be used for sampling unless the interior and exterior portions of the pump and the discharge hoses are thoroughly cleaned. Blank samples should be collected to determine the adequacy of cleaning prior to collection of any sample using a pump other than a peristaltic pump.

4.7.2 Order of Sampling with Respect to Analytes

In many situations when sampling permanent or temporary monitoring wells, an adequate purge, with respect to turbidity, is often difficult to achieve. Removal and insertion of equipment after the purge and prior to actual sampling may negate the low turbidities achieved during purging and elevate turbidity back to unacceptable levels. For this reason, it is important that special efforts be used to minimize any disturbance of the water column after purging and to collect the aliquot for metals first. Therefore, the preferred order of sampling is metals first, followed by other inorganic analytes, extractable organic compounds and volatile organic compounds.

4.7.3 Filtering

As a standard practice, ground water samples will not be filtered for routine analysis. Filtering will usually only be performed to determine the fraction of major ions and trace metals passing the filter and used for flow system analysis and for the purpose of geochemical speciation modeling. Filtration is not allowed to correct for improperly designed or constructed monitoring wells, inappropriate sampling methods, or poor sampling technique.

When samples are collected for routine analyses and are filtered, both filtered and non-filtered samples will be submitted for analyses. Samples for organic compounds analysis should not be filtered. Prior to filtration of the ground water sample for any reason other than geochemical speciation modeling, the following criteria must be demonstrated to justify the use of filtered samples for inorganic analysis:

1. The monitoring wells, whether temporary or permanent, have been constructed and developed in accordance with the SESD Guidance Document, Design and Installation of Monitoring Wells (SESDGUID-001).

2. The ground water samples were collected using sampling techniques in accordance with this section, and the ground water samples were analyzed in accordance with USEPA approved methods.
3. Efforts have been undertaken to minimize any persistent sample turbidity problems. These efforts may consist of the following:
 - Redevelopment or re-installation of permanent ground water monitoring wells.
 - Implementation of low flow/low stress purging and sampling techniques.
4. Turbidity measurements should be taken during purging and sampling to demonstrate stabilization or lack thereof. These measurements should be documented in the field notes. If the ground water sample appears to have either a chemically-induced elevated turbidity, such as would occur with precipitate formation, or a naturally elevated colloid or fine, particulate-related turbidity, filtration will not be allowed.

If filtration is necessary for purposes of geochemical modeling or other **pre-approved** cases, the following procedures are suggested:

1. Accomplish in-line filtration through the use of disposable, high capacity filter cartridges (barrel-type) or membrane filters in an in-line filter apparatus. The high capacity, barrel-type filter is preferred due to the higher surface area associated with this configuration. If a membrane filter is utilized, a minimum diameter of 142 mm is suggested.
2. Use a 5 μm pore-size filter for the purpose of determining the colloidal constituent concentrations. A 0.1 μm pore-size filter should be used to remove most non-dissolved particles.
3. Rinse the cartridge or barrel-type filter with 500 milliliters of the solute (groundwater to be sampled) prior to collection of sample. If a membrane filter is used, rinse with 100 milliliters of solute prior to sample collection.

Potential differences could result from variations in filtration procedures used to process water samples for the determination of trace element concentrations. A number of factors associated with filtration can substantially alter "dissolved" trace element concentrations; these include filter pore size, filter type, filter diameter, filtration method, volume of sample processed, suspended sediment concentration, suspended sediment grain-size distribution, concentration of colloids and colloiddally-associated trace elements, and concentration of organic matter. Therefore, consistency is critical in the comparison of short-term and long-term results. Further guidance on filtration may be obtained from the following: 1) Metals in Ground Water: Sampling Artifacts and Reproducibility; 2) Filtration of Ground Water Samples for Metals Analysis; and 3) Ground Water Sampling - A Workshop Summary. See Section 1.4, References, for complete citation for these documents.

Bacterial Sampling

Whenever wells (normally potable wells) are sampled for bacteriological parameters, care must be taken to ensure the sterility of all sampling equipment and all other equipment entering the well. Further information regarding bacteriological sampling is available in the following: 1) Sampling for Organic Chemicals and Microorganisms in the Subsurface; 2) Handbook for Evaluating Water Bacteriological Laboratories; and 3) Microbiological Methods for Monitoring the Environment, Water and Wastes. See Section 1.4, References, for complete citation for these documents.

4.8 Specific Sampling Equipment Quality Assurance Techniques

All equipment used to collect ground water samples shall be cleaned as outlined in the SESD Operating Procedure for Field Equipment Cleaning and Decontamination (SESDPROC-205) or SESD Operating Procedure for Field Equipment Cleaning and Decontamination at the FEC (SESDPROC-206) and repaired, if necessary, before being stored at the conclusion of field studies. Cleaning procedures utilized in the field or field repairs shall be thoroughly documented in field records.

4.9 Auxiliary Data Collection

During ground water sample collection, it is important to record a variety of ground water related data. Included in the category of auxiliary data are water levels measured according to the SESD Operating Procedure for Groundwater Level and Well Depth Measurement (SESDPROC-105), well volume determinations (Section 3.1.1, Purging and Purge Adequacy), pumping rates during purging (see below), and occasionally, drillers or boring logs. This information should be documented in the field records.

4.9.1 Well Pumping Rate – Bucket/Stop Watch Method

The pumping rate for a pump can be determined by collecting the discharge from the pump in a bucket of known volume and timing how long it takes to fill the bucket. The pumping rate should be in gallons per minute. This method shall be used primarily with pumps with a constant pump rate, such as gasoline-powered or electric submersible pumps. Care should be taken when using this method with some battery-powered pumps. As the batteries' charge decreases, the pump rate also decreases so that pumping rate calculations using initial, high pump rates may be erroneously high. If this method is used with battery-powered pumps, the rate should be re-checked frequently to ensure accuracy of the pumping rate calculations.

Attorney-Client Privilege
Attorney Work Product/Prepared at the Direction of Counsel

Appendix B

PFAS Field Sampling Guide

TGI – Per- and Polyfluoroalkyl Substances (PFAS) Field Sampling Guide

Rev: 10

Rev Date: January 26, 2022

Version Control

Issue	Revision No.	Date Issued	Page No.	Description	Reviewed By
	0	April 27, 2017	All	Initial Release	Erica Kalve Erika Houtz Sue Tauro
	1	June 19, 2018	1 through 4 and 17	Updated Information on Sampling Materials	Erica Kalve Erika Houtz
	2	October 15, 2018	6 to 16	Minor updates on laboratory elements, updates to decontamination procedures, and clarification on equipment and reagent blank collection	Erika Houtz Erica Kalve
	3	December 17, 2018	4, 6, 17	Removed Sharpies from acceptable field writing implements; Changed language in Section 3.2 and Section 10.5 to provide stricter guidance for DoD projects.	Erika Houtz, Erica Kalve
	4	March 26, 2019	4,5	Removed Citranox from acceptable Decon solutions in Table 1a, added all fluoropolymer containing materials to prohibited items in Table 1b. Made a correction that Liquinox contains trace levels of 1,4 Dioxane, not Alconox.	Erika Houtz
	5	October 16, 2020	14	Added Air Force preference to sample surface water at surface for Air Force investigations.	Erika Houtz

6	March 23, 2021	4, 5, 7, 12, 13, 14, 15, 16, 17	Made clarifications that fine/ultra-fine point Sharpies are allowed. Referenced 2018 MDEQ sampling guidance. Made updates to 'After Sample Collection' in Section 7.	Kevin Engle
7	April 18, 2021	All	Changed title from Poly- and Perfluoroalkyl Substances to “Per- and Polyfluoroalkyl Substances” and changed PFASs to PFAS.	Rosario Varrella, Erika Houtz
8	May 4, 2021	12, 13, 15, 16	Clarified that sample containers should have an HDPE lined screw cap and that LDPE plastic sheeting should be used.	Kevin Engle, Erika Houtz
9	October 20, 2021	Note that numbers have shifted one page forward relative to prior versions. 5, 7, 9-12, 15, 16, 18-25.	Specific acceptable sunscreen and insect repellent brands were added to Table 1. Clarified language regarding footwear and H&S trainings. Laboratories section and Section 10.5 was updated to reflect new laboratory names and an updated version of the QSM. Sections 5 and 6 were updated to provide clearer language on health and safety protocols for sunscreen, insect repellent, and rain events. Added language to specify decontamination of reusable equipment prior to initial use in Section 7.1. Section 8 on Waste Management was updated to state that	Kevin Engle, Erika Houtz

waste storage and disposal should be determined in the site specific workplan. Section 9 was updated to include Rite in the Rain® notebooks as approved for PFAS sampling. Changed the term “sample port” to “sample location” when describing where to place plastic sheeting. Section 10.1 was updated to indicate an equipment blank can be collected for unvetted hazard controls that contact a sample. References were updated to include the newer version of the DoD QSM, MDEQ Sampling Guidance, and California State Water Board PFAS Sampling Guidance.

10	January 26, 2022	Various, Section 7	<p>TGI formatted to comply with new QMS TGI template and Arcadis brand compliance.</p> <p>Indicated to avoid use of anti-fog spray on safety glasses due to possible presence of PFAS.</p>
----	------------------	--------------------	--

Approval Signatures

Prepared by:

1/26/2022



Kevin Engle, PG Geologist (Preparer)

Date

Reviewed by:

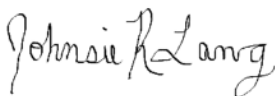

1/26/2022

Johnnie K. Lang, PhD (Subject Matter Expert)

Date

1 Introduction

This document is intended to provide guidance to field staff sampling for Per- and Polyfluoroalkyl Substances (PFAS). The content in this document describes the intended use, scope and application, personnel qualifications, equipment, cautions, health and safety considerations, procedures, waste management, data recording and management, and quality assurance of PFAS sampling.

2 Intended Use and Responsibilities

This document describes general and/or specific procedures, methods, actions, steps, and considerations to be used and observed by Arcadis staff when performing work, tasks, or actions under the scope and relevancy of this document. This document may describe expectations, requirements, guidance, recommendations, and/or instructions pertinent to the service, work task, or activity it covers.

It is the responsibility of the Arcadis Certified Project Manager (CPM) to provide this document to the persons conducting services that fall under the scope and purpose of this procedure, instruction, and/or guidance. The Arcadis CPM will also ensure that the persons conducting the work falling under this document are appropriately trained and familiar with its content. The persons conducting the work under this document are required to meet the minimum competency requirements outlined herein, and inquire to the CPM regarding any questions, misunderstanding, or discrepancy related to the work under this document.

This document is not considered to be all inclusive nor does it apply to all projects. It is the CPM's responsibility to determine the proper scope and personnel required for each project. There may be project- and/or client- and/or state-specific requirements that may be more or less stringent than what is described herein. The CPM is responsible for informing Arcadis and/or Subcontractor personnel of omissions and/or deviations from this document that may be required for the project. In turn, project staff are required to inform the CPM if or when there is a deviation or omission from work performed as compared to what is described herein.

In following this document to execute the scope of work for a project, it may be necessary for staff to make professional judgment decisions to meet the project's scope of work based upon site conditions, staffing expertise, regulation-specific requirements, health and safety concerns, etc. Staff are required to consult with the CPM when or if a deviation or omission from this document is required that has not already been previously approved by the CPM. Upon approval by the CPM, the staff can perform the deviation or omission as confirmed by the CPM.

3 Scope and Application

The purpose of this Technical Guidance Instructions (TGI) is to provide guidance on field sampling to be used for **Per- and Polyfluoroalkyl Substances** (PFAS). This protocol was adapted from various sources including Arcadis Australia, Transport Canada, and the U.S Army Corp of Engineers (USACE) Omaha. In general, sampling techniques used for PFAS site characterization are consistent with conventional sampling techniques used in the environmental industry, but special consideration is made regarding PFAS-containing materials and cross-contamination potential. **Table 1a** provides a summary of materials that have been approved for site investigation; this list is expected to grow longer as industry experience increases. **Table 1b** provides a summary of field equipment and materials that have available testing information and/or industry knowledge regarding

PFAS cross-contamination potential, and it is recommended that these materials be prohibited for sample collection; for materials that are suspected of containing PFAS and/or to retain PFAS, these recommendations are considered preliminary and subject to change. Further discussion of approved and prohibited materials is found throughout this document.

Table 1a: Summary of Acceptable Sampling Equipment and Materials for PFAS Site Investigations

Sampling Materials	Additional Considerations	References
<i>Water Sampling Materials</i>		
High density polyethylene (HDPE) or silicone tubing materials	--	DER 2016; USACE 2016; NHDES 2016; MassDEP 2017
HDPE HydraSleeves™	Low density polyethylene (LDPE) HydraSleeves™ are not recommended	USACE 2016; MassDEP 2017
<i>Drilling and Soil Sampling Materials</i>		
PFAS-free drilling fluids	--	DER 2016
PFAS-free makeup water	Confirm PFAS-free water source via laboratory analysis prior to investigation	--
Acetate liners	For use in soil sampling	USACE 2016
<i>Sample Containers and Storage</i>		
HDPE sample containers with HDPE lined lids for soil and water samples	Laboratory should provide; whole bottle analysis of aqueous samples combined with a solvent rinse of bottle is recommended	DER 2016, MassDEP 2017
Ice contained in plastic (polyethylene) bags (double bagged)	--	DER 2016; USACE 2016; NHDES 2016; MassDEP 2017
<i>Field Documentation</i>		
Ball point pens	--	MassDEP 2017
Standard paper and paper labels	--	DER 2016; USACE 2016; NHDES 2016; MassDEP 2017
Fine/Ultra-Fine point Sharpies®	Larger point Sharpies® should be avoided.	MDEQ 2018
<i>Decontamination</i>		
Water-only decontamination	Confirm PFAS-free water source via laboratory analysis prior to investigation	DER 2016

Sampling Materials	Additional Considerations	References
Alconox® or Liquinox® followed by deionized water or PFAS-free water rinse	Liquinox® known to contain trace levels of 1,4-dioxane	NHDES 2016; USACE 2016; MassDEP 2017
Methanol, isopropanol, or acetone	Special health and safety precautions are necessary	UNEP 2015; USACE 2016
<i>Sun and Biological Protection</i>		
OFF Deep Woods, Sawyer Permethrin	Apply >10 m away from sampling area	MDEQ 2018
Banana Boat, Coppertone, Neutrogena, Meijer, and L'Oreal Sunscreens	Apply >10 m away from sampling area	MDEQ 2018

Note: This list is considered preliminary and additional materials may be added as additional information becomes available. Project teams are expected to follow a methodical evaluation process of materials to be used and confirm acceptance prior to implementation of field activities.

Table 1b: Summary of Sampling Equipment and Materials Not Recommended for PFAS Site Investigations.

Sampling Materials	Known PFAS-Containing Materials	Suspected PFAS-Containing Materials	Materials with Potential to Retain PFAS	References
<i>Water Sampling Materials</i>				
Teflon®, PTFE-containing or other fluoropolymer coated or containing field equipment (e.g., tubing, bailers, liners, tape, plumbing paste, pump parts)	x			DER 2016; USACE 2016; NHDES 2016; MassDEP 2017
Passive diffusion bags			x	MassDEP 2017
LDPE HydraSleeves™			x	USACE 2016; MassDEP 2017
Water particle filters			x	MassDEP 2017
<i>Drilling and Soil Sampling Materials</i>				
Aluminum foil			x	DER 2016; USACE 2016; NHDES 2016; MassDEP 2017
Drilling fluid containing PFAS	x	x		DER 2016
<i>Sample Containers and Storage</i>				
Glass sample containers with lined lids			x	DER 2016; USACE 2016; NHDES 2016; MassDEP 2017

Sampling Materials	Known PFAS-Containing Materials	Suspected PFAS-Containing Materials	Materials with Potential to Retain PFAS	References
LDPE containers and lined lids			x	USACE 2016
Teflon® or PTFE- lined lids on containers (e.g., sample containers, rinsate water storage containers)	x			DER 2016; USACE 2016; NHDES 2016; MassDEP 2017
Reusable chemical or gel ice packs (e.g., BlueIce®)		x		DER 2016; USACE 2016; NHDES 2016; MassDEP 2017
Field Documentation				
Self-sticking notes and similar office products (e.g., 3M Post-it-notes)		x		DER 2016; USACE 2016; NHDES 2016; MassDEP 2017
Waterproof paper, notebooks, and labels	x			DER 2016, MassDEP 2017
Markers		x		NHDES 2016
Decontamination				
[Some] detergents and decontamination solutions (e.g., Decon 90® Decontamination Solution)	x	x		DER 2016; NHDES 2016; MassDEP 2017

Note: For materials that are suspected of containing PFAS, or have the potential to retain PFAS, project specific considerations may provide adequate justification for use during the field event. For example, further evaluation may be conducted in the form of pre-field equipment blank sample analysis.

Given the extremely low detection limits associated with PFAS analysis and the many potential sources of trace levels of PFAS, field personnel are advised to err on the side of caution by strictly following these protocols, frequently replacing nitrile gloves, and rinsing field equipment to help mitigate the potential for false detections of PFAS. A summary of other specific items related to field sampling for PFAS are discussed in the sections below.

This TGI applies to all Arcadis and subcontractor personnel involved in field sampling for PFAS.

4 Personnel Qualifications

4.1 Sampling Personnel

Field personnel must have current health and safety training, including 40-hour HAZWOPER training, up to date 8-hour refresher, site supervisor training, and site-specific training, as needed. In addition, field personnel will be versed in the other relevant SOPs (e.g., low flow sampling) and will possess the skills and experience necessary

to successfully complete the desired field work. The site Health and Safety Plan (HASP) and other documents will identify any other training requirements such as site-specific safety training or access control requirements.

4.2 Laboratories

These laboratories are example laboratories that could be used to analyze environmental media for PFAS, pending project approval:

- United States: Pace, SGS, Vista, ALS, and Eurofins
- Canada: AXYS-SGS and Bureau Veritas

Other laboratories may be used if they are appropriately accredited for PFAS analysis according to any project requirements. It is recommended that a laboratory is Environmental Laboratory Accreditation Program (ELAP)-accredited for PFAS analysis in accordance with the Department of Defense (DoD) Quality Systems Manual (QSM) 5.3 Table B-15 or any subsequent updates. **For all data collection efforts at DoD sites, PFAS data must be obtained using a method that is DoD ELAP-accredited under QSM 5.3 or later.**

5 Equipment List

The following equipment and materials must be available for sampling:

- Site plan of sampling locations, relevant work plan (or equivalent), and this TGI;
- Appropriate health and safety equipment, as specified in the site HASP;
- Dedicated plastic sheeting (preferably high-density polyethylene [HDPE]) or other clean surface to prevent sample contact with the ground;
- Conductivity/temperature/pH meter;
- Dissolved oxygen meter, oxidation reduction potential meter, and turbidity meter;
- Depth to water meter;
- If using low-flow groundwater sampling techniques, peristaltic pump (groundwater sampling)/bladder pump (with PFAS free bladder/ HDPE bladder), flow through cell, and accompanying HDPE and silicone tubing;
- Hydrasleeves™, if using Hydrasleeves™ for groundwater sampling;
- Metal trowel for soil samples; specialized soil/sediment sampling equipment as required;
- Brushes for scrubbing sampling equipment;
- Pens, pencils, and/or fine/ultra-fine point Sharpies® for writing;
- Clipboards, field binders, and field note pages that are not waterproof;
- Labeled sample bottles:
 - Water: HDPE bottles fitted with polypropylene screw cap only; some types of PFAS samples (primarily drinking water) may require preservative, which will be indicated by the laboratory conducting the analysis. The laboratory will specify the sample bottle volume.

- Soil and sediment: HDPE bottles fitted with polypropylene screw cap only; no preservatives. The laboratory will specify the sample bottle volume.
- If high concentrations of PFAS related to class B firefighting foams are expected, bring additional small vials to conduct field-based shaker tests for foaming;
- Ziploc® bags to hold ice and samples;
- Bottles containing “PFAS-free” water used for reagent blanks;
- Labeled, thoroughly decontaminated coolers for samples with ice; Blue ice is not permitted;
- Deionized or distilled water for initial decontamination rinsing;
- “PFAS-free” water provided by the laboratory for final decontamination rinsing;
- Methanol, isopropanol, or acetone if able to be brought safely to field site; especially important for decontamination during soil sampling;
- Alconox or Liquinox®;
- Packing and shipping materials;
- Groundwater and/or Sampling Log; and
- Chain-of-Custody (COC) Forms.

6 Cautions

6.1 Food Packaging

Some food packaging may be treated with PFAS-containing chemicals to prevent permeation of oil and water in the food outside of the packaging. To avoid potential food packaging-related PFAS contact:

- Do not bring any food outside of the field vehicles onsite and eat snacks and meals offsite.
- Wash hands after eating.
- Remove any field garments or outer layers prior to eating. Do not put them back on until done eating and hands are washed.

6.2 Field Gear

6.2.1 Clothing

Many types of clothing are treated with PFAS for stain and water resistance, in particular outdoor performance wear under brand names such as Gore-Tex®. To avoid potential clothing-related PFAS contact:

- Do not wear any outdoor performance wear that is water or stain resistant, or appears to be. Err on the side of caution.

- Wear pre-laundered (multiple washings, i.e., 6+) clothing that is not stain resistant or waterproof (unless made from the materials listed in Section 5.3.1).
- Natural fabrics such as cotton are preferred. Synthetic fabrics may also be acceptable if there is no indication on the label that the fabric is water and stain resistant.
- Most importantly, avoid contacting your clothing with sampling equipment, bottles, and samples.

6.2.2 Personal Protective Equipment

Safety Footwear

Some safety footwear has been treated to provide a degree of waterproofing and increased durability and may represent a source of trace PFAS. If at all possible, Gore-Tex footwear should not be worn and safety footwear without waterproofing should be worn; footwear that provides adequate safety from physical hazards is required and takes precedence over potential PFAS concerns. To avoid any PFAS cross contamination to samples from footwear:

- Do not contact your footwear with equipment, bottles, or samples in any way.
- Do not allow gloves used for sampling to come in contact with safety footwear.

Nitrile Gloves

Wear disposable nitrile gloves at all times. Don a new pair of nitrile gloves **before** the following activities at each sample location:

- Decontamination of re-usable sampling equipment;
- Contact with sample bottles or “PFAS-free” water bottles;
- Insertion of anything into the sample ports (e.g., HDPE tubing); and
- Handling of any quality assurance/quality control (QA/QC) samples including field blanks and equipment blanks.

Don a new pair of nitrile gloves **after** the following activities:

- Handling of any non-dedicated sampling equipment;
- Contact with contaminated surfaces; or
- When judged necessary by field personnel.

6.3 Personal Hygiene

- Shower at night.
- Do not use personal care products after showering such as lotions, makeup, and perfumes, UNLESS medically necessary.
- Use sunscreen and insect repellent as necessary for health and safety, i.e., if sampling is to occur outdoors in direct sunlight and/or if insect hazards may be present. Specific products that are acceptable for PFAS

sampling are listed in Table 1 and in Section 6.1. Apply sunscreen and insect repellent prior to initiating field sampling. If sunscreen and/or repellent need to be reapplied, ensure a safe distance away from the sampling locations and equipment (i.e., more than 10 meters (m) away). Wash hands after application and don new gloves following hand washing.

6.4 Visitors

Visitors to the site are asked to remain at least 10 m from sampling areas.

7 Health and Safety Considerations

7.1 Biological and Environmental Hazard Controls

7.1.1 Sunscreens and Insect Repellents

When site conditions warrant, insect repellent and sunscreen should be applied. Some insect repellents and sunscreen have been approved for PFAS sampling by individual states. According to Michigan Department of Environmental Quality (MDEQ; now known as Michigan Department of Environment, Great Lakes, and Energy [EGLE]), the products below are allowable (MDEQ 2018). Note that California State Water Quality Control Board's PFAS sampling guidance refers to MDEQ/EGLE's allowable list of sunscreens and insect repellents (California State Water Quality Control Board 2020).

Insect Repellents

- OFF Deep Woods
- Sawyer Permethrin

Sunscreen

- Banana Boat Sport Performance Sunscreen Lotion Broad Spectrum SPF 30
- Meijer Sunscreen Lotion Broad Spectrum SPF 30
- Neutrogena Ultra-Sheer Dry-Touch Sunscreen Broad Spectrum SPF 30
- Banana Boat for Men Triple Defense Continuous Spray Sunscreen SPF 30
- Banana Boat Sport Performance Coolzone Broad Spectrum SPF 30
- Banana Boat Sport Performance Sunscreen Lotion Broad Spectrum SPF 30
- Banana Boat Sport Performance Sunscreen Stick SPF 50
- Coppertone Sunscreen Lotion Ultra Guard Broad Spectrum SPF 50
- Coppertone Sport High-Performance AccuSpray Sunscreen SPF 30
- Coppertone Sunscreen Stick Kids SPF 55
- L'Oréal Silky Sheer Face Lotion 50+
- Meijer Clear Zinc Sunscreen Lotion Broad Spectrum SPF 15, 30 and 50
- Meijer Wet Skin Kids Sunscreen Continuous Spray Broad Spectrum SPF 70
- Neutrogena Beach Defense Water + Sun Barrier Lotion SPF 70
- Neutrogena Beach Defense Water + Sun Barrier Spray Broad Spectrum SPF 30
- Neutrogena Pure & Free Baby Sunscreen Broad Spectrum SPF 60+

Please plan for sampling events and purchase these products ahead of time. For any sunscreens and bug sprays, including those listed above, always follow these instructions for application:

- Insect repellents and sunscreen should be applied away from the work area prior to initiating sampling.
- When re-applying, stay at least 10 m away from the sampling locations and equipment.
- Wash hands after application and don new nitrile gloves.

7.1.2 Rain Event

Special care should be taken when rain is falling at the project site:

- Field sampling during extreme rainfall should be avoided if possible. If sampling needs to take place during a rain event (or other extreme weather condition), ensure the rain gear or other safety clothing is appropriate. For example, rain gear made from the following materials is allowable: polyurethane, PVC, wax coated fabrics, rubber/neoprene, uncoated Tyvek® (MDEQ 2018).
- If project timelines are tight, consider the use of a gazebo tent that can be erected over the top of the monitoring well to provide shelter from the rain. The canopy material is possibly a PFAS-treated surface and should be managed as such; therefore, wear gloves when moving the tent, change them immediately after moving the tent, and avoid further contact with the tent until all sampling activities have been finished and the team is ready to move on to the next site.

7.1.3 Other H&S Considerations

- ***If an unapproved or potentially suspect hazard control is needed for health and safety, apply or keep that control away from the samples, document its use in field notes, and, if it does contact a sample, take an equipment blank with that material.***
- The ability to safely access the surface water sampling locations must be verified before sampling.
- Field activities must be performed in accordance with the site HASP, a copy of which will be present onsite during such activities.
- Safety hazards associated with sampling surface water include fast-moving water, deep water, and steep slopes close to sampling sites. Use extreme caution when approaching sampling sites.
- If thunder or lightning is present, discontinue sampling and take cover until 30 minutes have passed after the last occurrence of thunder or lightning.
- Use caution when removing well caps as well may be under pressure, cap can dislodge forcefully and cause injury.
- Avoid the use of anti-fog sprays on glasses, which may contain PFAS. It's recommended to instead purchase pre-treated anti-fog safety glasses.

8 Procedure

8.1 Field Equipment Cleaning

Reusable field sampling equipment will require cleaning before initial use and between uses. For groundwater sampling, between uses, decontaminate the flow-through cell and any non-dedicated equipment (i.e., interface probe of depth to water meter) that comes into contact with well water. Trowels and other materials used to sample soil samples will also require decontamination, although dedicated, single use equipment such as liners should be used where possible.

After donning a new pair of nitrile gloves:

- Rinse sampling equipment with Alconox or Liquinox® cleaning solution; Scrub equipment with a plastic brush if needed;
- Rinse two times with distilled water or deionized water;
- Rinse one time with “PFAS-free” water or once with methanol/isopropanol/acetone, if it is available, and once with “PFAS-free” water; organic solvents are especially useful for decontaminating soil sampling equipment. If organic cleaning solvents cannot be brought to site, scrub equipment a second time after a single distilled or deionized water rinse, then rinse two times with distilled or deionized water and once with “PFAS-free” water (i.e., two scrubbing and four water rinsings total).
- Collect all rinsate in a sealed pail for disposal. Do not reuse decontamination solutions between sampling locations.

8.2 Borehole/Monitoring Well Development

If a drill rig is being used to drill for soil cores or to install monitoring wells, wear clean nitrile gloves before collecting each continuous soil sample. Additional requirements include the following:

- Verify in writing with the manufacturer that single-use liners used to collect each sample are made of a material that does not contain PFAS;
- Collect soil samples in laboratory-supplied HDPE bottles.
- Store the sample bottles in coolers and keep at a temperature of 0 to 6°C until transported to the laboratory.

8.2.1 Well Condition Survey/ Water Level Monitoring

Using equipment that has been thoroughly decontaminated according to the procedures in Section 7.1, conduct the well condition surveys and water level monitoring:

- Conduct monitoring well inspections and record water levels.
- Use an interface probe to evaluate presence/absence of non-aqueous phase liquid (NAPL).
- Measure the depth to water from the top of the polyvinyl chloride (PVC) riser and the total depth of the well.
- Record information in the field notes.

8.2.2 Monitoring Well Development and Purging

Follow these requirements for monitoring well development and purging:

- Do not use Teflon™ tubing for purging or sample collection. HDPE tubing is acceptable.
- Do not re-use materials between wells. Upon completion of use, remove all disposable materials (such as HDPE and/or silicone tubing) and place in heavy duty garbage bags for disposal.
- During development of the well, create sufficient energy to agitate the water column and create flow reversals in the well screen, filter pack and formation to loosen fine-grained materials and draw them into the well. The pumping or bailing action should then draw all drilling fluids and fine-grained material out of the borehole and adjacent formation and then out of the well. Review the Arcadis Monitoring Well Development guidance (Arcadis 2010) for more detailed information.
- Follow the low-flow purge and sampling techniques per the U.S. Protection Agency's (EPA's) guidance document titled *Low Stress (Low Flow) purging and Sampling Procedure for the Collection of Ground Water Samples from Monitoring Wells* (2010) and ASTM's standard titled *Standard Practice for Low-Flow Purging and Sampling for Wells and Devices Used for Ground-Water Quality Investigations* (2002). Also available for review is the Arcadis Low-Flow Groundwater Purging and Sampling Procedures for Monitoring Wells (Arcadis 2011).
- To purge the well, if using HDPE tubing and a peristaltic pump, insert the end of the tubing to the approximate depth of the midpoint of the screened section of the monitoring wells. Measure the length of HDPE tubing to be inserted into each monitoring well and pre-cut it to approximate lengths (such as the previously measured arm span of a field technician) to avoid contact with any materials other than the monitoring well and peristaltic pump. Flow rates should be as low as can be reasonably achieved. Collect and appropriately dispose of purge water.
- Silicone tubing should direct the purge water through a flow-through cell for field parameter measurements of pH, conductivity, temperature, dissolved oxygen, and turbidity. Calibrate the instrument in the field prior to use. Decontaminate the instrument and flow-through cell at each monitoring well location before purging.
- Record field parameters in intervals (generally of 3-minute duration) to ensure purge water has cycled through the flow-through cell. Sample the wells after field parameter measurements indicate stabilization, which allows collection of representative formation water (generally acceptable standards are three consecutive pH readings to within ± 0.1 units, and three consecutive conductivity, temperature and dissolved oxygen measurements to within 3%). Turbidity must be monitored, but does not need to be used as a stabilization indicator of purge completion. Record field parameter measurements at each well. Drawdown should be monitored throughout the purge.
- If wells are suspected to be dewatering throughout the purge (i.e., reduced flow rate/difficulty pumping water or bubbles begin to come through the flow through cell), turn off the pump and allow the water level to recover for ½ hour, followed by sample collection. Document these activities in the field notes.

8.3 Sample Collection

Different laboratories may supply sample collection bottles of varying sizes depending on the type of media to be sampled.

8.3.1 Sample Containers

- Collect samples in HDPE bottles fitted with a HDPE lined (no Teflon™) screw cap.
- Complete bottle labels after the caps have been placed back on each bottle.
- Do not use glass bottles due to potential loss of analyte through adsorption. This is particularly important for aqueous samples.
- Review with analytical lab the sample size, sample container, etc. depending upon the type of PFAS analysis that is being requested.

8.3.2 Soil Sampling

Before Sample Collection

- Place LDPE plastic sheeting adjacent to the sample location for use as a clean work area, if conditions allow. Otherwise, prevent sampling equipment from contacting the ground or other surface that could compromise sample integrity.
- Trowels or drilling equipment that will come into contact with a sample should be decontaminated prior to sample collection, preferably with methanol/isopropanol/acetone;
- Don a new set of nitrile gloves. Do not use gloved hands to subsequently handle papers, pens, clothes, etc., before collecting samples.
- Use the HDPE bottles that are supplied by the laboratory. Make sure that the caps remain on the bottle until immediately prior to sample collection.

During Sample Collection

- Collect soil samples using a clean stainless-steel trowel or with single-use PFAS-free liners;
- Place soil samples in labeled HDPE bottles supplied by the laboratory.
- Note the time on the sample label.
- Collect any necessary duplicates/co-located samples and matrix spikes – verify with laboratory whether they need to be collected in separate sample bottles.
- Collect any necessary equipment blanks. The best timing to collect equipment blanks is immediately after the collection of a sample likely to contain high concentrations of PFAS, after the sampling equipment has been appropriately decontaminated.
- Collect any necessary field reagent blanks. This sample should be collected after field staff return from an offsite break (e.g., lunch) to capture any potential cross-contamination from field personnel.

After Sample Collection

- Place each sample bottle in two sealed Ziploc® bags. Another brand of LDPE bag is acceptable.
- Record the label information and time of sampling in the field notes.
- Place soil sample bottles in coolers that are durable in transportation and keep the temperature between 0 and 6°C until transported to the laboratory. Do not use blue ice.

8.3.3 Groundwater Sampling

Before Sample Collection

- Place LDPE plastic sheeting adjacent to the sample location for use as a clean work area, if conditions allow. Otherwise, prevent sampling equipment from contacting the ground or other surface that could compromise sample integrity.
- Don a new set of nitrile gloves. Do not use gloved hands to subsequently handle papers, pens, clothes, etc., before collecting samples.
- Use the labeled HDPE bottles that are supplied by the laboratory. Make sure that the caps remain on the bottle until immediately prior to sample collection.
- Measure depth to water and field parameters. Turbidity and the physical appearance of the purged water should be noted on the Groundwater Sampling Log.

During Sample Collection

- Start groundwater sample collection upon stabilization of field parameters.
- If low-flow groundwater sampling techniques are being used, disconnect the silicone tubing from the flow-through cell, enabling collection of groundwater samples without passing through the cell.
- Hydrasleeves are also considered acceptable for sampling of PFAS in groundwater – consult the project manager to determine which technique should be used. In general, low flow sampling is preferable.
- Collect groundwater samples (to the neck of the bottle, some headspace is acceptable) from the dedicated sampling ports at the center of the well screen. While collecting the sample, make sure the bottle cap remains in the other hand of the sampler, until replaced on the bottle.
- To mitigate cross contamination, collect groundwater samples in a pre-determined order from least impacted to greater impacted based on previous analytical data or knowledge about past activities at the site. If no analytical data are available, samples are to be collected in the following order:
 1. First sample the upgradient well(s).
 2. Next, sample the well located furthest downgradient of the interpreted or known source.
 3. The remaining wells should be progressively sampled in order from downgradient to upgradient, such that the wells closest to the interpreted or known source are sampled last.
- NOTE: If high concentrations of PFAS related to class B firefighting foams are expected in a groundwater sample, conduct a Shaker test by collecting and shaking a small portion of the sample (~10 to 25 mL) on site in a small disposable vial. If foaming is noted within the sample, document the foaming when samples are

submitted for analysis; the 'shaker test' vial can then be disposed. This shaker test provides information about how each of the samples should be handled analytically.

- After collecting the sample, tightly screw on the polypropylene cap (snug, but not too tight). This will minimize leaking or cross contamination of the sample. Most PFAS, including all analytes measured by USEPA Method 537, are not volatile at environmental pH.
- Note the time on the sample label.
- Collect any necessary duplicates and matrix spikes. As the laboratory should be analyzing the entire aqueous sample rather than sub-sampling, separate bottles will be required for these samples.
- Collect any necessary equipment blanks. The best timing to collect equipment blanks is immediately after the collection of a sample likely to contain high concentrations of PFAS, after the sampling equipment has been appropriately decontaminated.
- Collect any necessary field reagent blanks. This sample should be collected after field staff return from an offsite break (e.g., lunch) to capture any potential cross-contamination from field personnel.
- Do not rinse PFAS sample bottles during sampling. Do not filter samples.

After Sample Collection

- Place each sample bottle in two sealed Ziploc® bags. Another brand of LDPE bag is acceptable.
- Record the label information and time of sampling in the field notes and COC. Note 'shake test' results if appropriate.
- Place groundwater samples in coolers that are durable in transportation and keep the temperature between 0 and 6°C until transported to the laboratory. **Do not use blue ice. Store PFAS samples in a separate cooler from other types of samples.**

Treat all disposable sampling materials as single use and dispose of them appropriately after sampling at each monitoring well.

8.3.4 Sediment Sampling

Before Sample Collection

- Place LDPE plastic sheeting adjacent to the sample location for use as a clean work area, if conditions allow. Otherwise, prevent sampling equipment from contacting the ground or other surface that could compromise sample integrity.
- Don a new set of nitrile gloves. Do not use gloved hands to subsequently handle papers, pens, clothes, etc., before collecting samples.
- Use the HDPE bottles that are supplied by the laboratory. Make sure that the caps remain on the bottle until immediately prior to sample collection.

During Sample Collection

- Where surface water samples and sediment samples are collected at the same location, collect surface water samples first to minimize siltation.

- Collect sediment samples either manually using a stainless-steel trowel or using a petite ponar grab sampler, depending on field conditions at each sampling location during sampling program.
- Collect sediment samples from the upper 10 cm of sediment.
- For a sample to be acceptable overlying, low turbidity water must be present.
- Decant the overlying water and use a stainless-steel trowel to collect only the upper 5 centimeters (cm) of sediment.
- Collect sediment samples directly into laboratory-supplied bottles that are suitable in both material and size.
- Do not overfill the sample bottle.
- Make sure that the sample does not contain vegetation, that the sediment is undisturbed, and that the sampler shows no signs of winnowing or leaking.
- Make sure bottle caps remain in the gloved hand of the sampler until sampling is complete and caps are replaced on the bottle.
- Note the time on the sample label.
- Collect any necessary duplicates and matrix spikes.
- Collect any necessary equipment blanks. The best timing to collect equipment blanks is immediately after the collection of a sample likely to contain high concentrations of PFAS, after the sampling equipment has been appropriately decontaminated.
- Collect any necessary field reagent blanks. This sample should be collected after field staff return from an offsite break (e.g., lunch) to capture any potential cross-contamination from field personnel.

After Sample Collection

- Place each sample bottle in two sealed Ziploc® bags. Another brand of LDPE bag is acceptable.
- Record the label information and time of sampling in the field notes.
- Place samples in coolers that are durable in transportation and keep the temperature between 0 and 6°C until transported to the laboratory. **Do not use blue ice. Store PFAS samples in a separate cooler from other types of samples.**
- Measure surface water pH, conductivity, temperature, and total dissolved solids (TDS) at each location **after** both surface water and sediment sampling is completed.

8.3.5 Surface Water Sampling

Before Sample Collection

- Place LDPE plastic sheeting adjacent to the sample location for use as a clean work area, if conditions allow. Otherwise, prevent sampling equipment from contacting the ground or other surface that could compromise sample integrity.
- Don a new set of nitrile gloves. Do not use gloved hands to subsequently handle papers, pens, clothes, etc., before collecting samples.

- Use the HDPE bottles that are supplied by the laboratory. Make sure that the caps remain on the bottle until immediately prior to sample collection.

During Sample Collection

- Avoid sampling the surface, in general.
- However, for Air Force investigations, collect samples from the water surface.
- Where surface water samples and sediment samples are collected at the same location, collect surface water samples first to minimize siltation.
- Collect surface water samples directly into laboratory-supplied bottles; wide-mouth bottles may be preferable to narrow mouth bottles for ease of surface water collection.
- Make sure bottle caps remain in the gloved hand of the sampler until sampling is complete and caps are replaced on the bottle.
- Note the time on the sample bottle.
- Collect any necessary duplicates and matrix spikes. As the laboratory should be analyzing the entire aqueous sample rather than sub-sampling, separate bottles will be required for these samples.
- Collect any necessary equipment blanks. The best timing to collect equipment blanks is immediately after the collection of a sample likely to contain high concentrations of PFAS, after the sampling equipment has been appropriately decontaminated.
- Collect any necessary field reagent blanks. This sample should be collected after field staff return from an offsite break (e.g., lunch) to capture any potential cross-contamination from field personnel.

After Sample Collection

- Place each sample bottle in two sealed Ziploc® bags. Another brand of LDPE bag is acceptable.
- Record the label information and time of sampling in the field notes.
- Place samples in coolers that are durable in transportation and keep the temperature between 0 and 6°C until transported to the laboratory. **Do not use blue ice. Store PFAS samples in a separate cooler from other types of samples.**
- Measure surface water pH, conductivity, temperature, and TDS at each location **after** both surface water and sediment sampling.

8.4 Shipping

- If samples cannot be shipped the same day as collected, arrange an appropriate means of keeping the samples cool overnight and maintain the temperature between 0 and 10°C for the first 48 hours after collection, and then between 0 and 6°C thereafter.
- Store samples in appropriate transport bottles (coolers) with ice (Ziploc® bags for use as ice containers) with appropriate labeling. **Do not use blue ice. Store PFAS samples in a separate cooler from other types of samples.**

- Complete the appropriate procedures for COC, handling, packing, and shipping.
- Fill out and check COC Forms against the labels on the sample bottles progressively after each sample is collected.
- Place all disposable sampling materials (such as plastic sheeting, and health and safety equipment) in appropriate containers.
- Ship samples via courier service with priority overnight delivery. Tracking numbers for all shipments should be provided and recorded after they have been sent out to ensure their timely delivery.
- Do not ship samples via Fed Ex for Saturday delivery.

9 Waste Management

All rinsate should be collected in a sealed pail for disposal. Drill cuttings and purge water will be managed as specified in the Field Sampling Plan (FSP) or Work Plan, and according to state and/or federal requirements. PPE and decontaminated fluids will be contained separately and staged at the sampling location. Containers must be labeled at the time of collection. Labels will include date, location(s), site name, city, state, and description of matrix contained (e.g., soil, groundwater, PPE). General guidelines for investigation derived waste (IDW) handling and storage are set forth in a separate IDW guidance document (Arcadis 2009).

Typical waste characterization procedures include collection of a composite sample of the drill cutting material and a composite sample of the purge water for laboratory analysis. Samples are typically analyzed for disposal toxicity characteristic leaching procedure (TCLP) analysis for metals and VOCs. For PFAS, a simple leach test with neutral pH water may be more indicative of actual risk. Additionally, generators of waste are required to include analysis of other constituents that are reasonably believed to be present including (in this case) PFAS.

Waste storage and final waste disposition should be determined in the site specific workplan.

10 Data Recording and Management

Digital data collection is the Arcadis standard using available FieldNow® applications that enable real-time, paperless data collection, entry, and automated reporting. Paper forms should only be used as backup to FieldNow® digital data collection and/or as necessary to collect data not captured by available FieldNow® applications. The Field Now® digital form applications follow a standardized approach, correlate to most TGIs and are available to all projects accessible with a PC or capable mobile device. Once the digital forms are saved within FieldNow®, the data is instantly available for review on a web interface. This facilitates review by project management team members and SMEs enabling error or anomalous data detection for correction while the staff are still in the field. Continual improvements of FieldNow® applications are ongoing, and revisions are made as necessary in response to feedback from users and subject matter experts.

If digital data collection isn't possible, waterproof field books should be avoided for field notes. Instead, field notes on loose paper on Masonite, plastic, or aluminum clip boards is preferred. Please note that newer Rite in the Rain® notebooks are approved for PFAS sampling. Other requirements for field notes include:

- Pens, pencils, and fine/ultra-fine point Sharpies® may be used.
- Keep field notes and writing implements away from samples and sampling materials.
- One person should conduct sampling while another records field notes.

- Do not write on sampling bottles unless they are closed.

10.1 Other Project Documentation

- Complete groundwater and/or soil sampling logs.
- Make sure COC Forms are properly completed. Verify which PFAS analytes (e.g., just PFOS and PFOA, some or all of the 537 list, etc.) are required for analysis and note on the COC.

11 Quality Assurance

Refer to quality control requirements for the project to ensure that appropriate quality assurance and quality control (QA/QC) samples are collected. When collecting QA/QC samples, the same guidelines apply as when collecting regular samples – specifically that:

- Samples should be collected in laboratory-supplied HDPE bottles;
- Bottle caps must remain in the hand of the sampler until replaced on the bottle;
- Labels must be completed after the caps have been placed back on each bottle; and
- Samples must be stored in appropriate transport bottles (coolers) with ice (Ziploc® bags for use as ice containers) with appropriate labeling. **Do not use blue ice. Store PFAS samples in a separate cooler from other types of samples.**

11.1 Equipment Blanks (if relevant)

QA/QC sampling typically includes daily collection of equipment blanks using the laboratory-supplied “PFAS-free” water. For peristaltic pump tubing, laboratory supplied “PFAS-free” water should be poured into a clean HDPE sample bottle and then pumped through new HDPE tubing using the peristaltic pump (with new silicone tubing). The best timing to collect equipment blanks is immediately after the collection of a sample likely to contain high concentrations of PFAS, after the sampling equipment has been appropriately decontaminated. Note that an equipment blank can also be collected if an unapproved or potentially suspect hazard control is needed for health and safety and it contacts a sample, i.e., that material would be exposed to PFAS free water then the water would be collected in a separate sample container.

11.2 Field Duplicates

QA/QC sampling typically includes the collection of one field duplicate for every 10 or 20 samples collected. Each duplicate sample will be collected immediately after the initial sample of which it is a duplicate into a separate laboratory-provided sample bottle. Do not indicate to the laboratory which sample the duplicate replicates, i.e., it should be given a blind reference on the COC and sample name such as “duplicate”.

11.3 Field Reagent Blanks

QA/QC sampling for PFAS typically includes the submission of one laboratory supplied field reagent blank per day. The field reagent blank sample is brought to the site in a laboratory-supplied sample bottle. Field staff

transfer the laboratory-supplied reagent blank to an empty sample bottle. This sample should be collected after field staff return from an offsite break (e.g., lunch) to capture any potential cross-contamination from field personnel and should be placed in the same cooler as the other PFAS samples.

11.4 Matrix Spikes (optional in some cases)

QA/QC sampling includes submitting a sample to be used as a matrix spike if the project requires it. If a separate sample bottle is required, an additional sample will be collected immediately after the initial sample of which it is a duplicate into a separate laboratory-supplied sample bottle.

11.5 Laboratory Analytical QA/QC

- Arcadis recommends that any request for PFAS analysis in groundwater or soil should be conducted by an ELAP-accredited method compliant with QSM 5.3 Table B-15. Requirements laid out in Table B-15 strictly govern acceptable laboratory data quality for PFAS analysis in environmental samples. **For all data collection efforts at DoD sites, PFAS data must be obtained using a method that is DoD ELAP-accredited under QSM 5.3 or later.**
- Laboratory QA/QC should consist of one laboratory blank and one laboratory control sample (or blank spike) per batch of samples, and additional QA/QCs as indicated by the laboratory QA/QC procedures.
- Isotope dilution should be used for quantification with isotope-labeled surrogate standards, as available, according to the guidelines of QSM 5.3 Table B-15. The USEPA has two drinking water methods (USEPA Method 537.1 and USEPA Method 533). Method 537.1 does not allow for isotope dilution but USEPA Method 533 requires isotope dilution.
- For drinking water, groundwater, and surface water samples, laboratories must extract the entire sample and include a solvent rinse of the bottle for analysis. Aqueous samples should generally not be sub-sampled prior to analysis, unless they are high concentration and require serial dilution (US DoD 2017).
- Soil samples should be analyzed in their entirety or thoroughly homogenized before extraction and analysis.
- As part of the internal QA/QC of laboratory results, relative percent difference (RPD) should be calculated between samples and corresponding field or laboratory duplicates. The laboratory quality assurance portion of the laboratory certificates should be reviewed to verify that all calculations/recoveries were within acceptable limits as established by the laboratory method and guidelines in Table B-15 of QSM 5.3 or later (USDoD 2019).

12 References

Arcadis Australia. 2017. Soil and Concrete Sampling for PFAS. April.

Arcadis. 2010. Monitoring Well Development, Rev. #2.2. March 22.

Arcadis. 2009. Investigation-Derived Waste Handling and Storage, Rev. #2. March 6.

Arcadis. 2011. Low-Flow Groundwater Purging and Sampling Procedures for Monitoring Wells, Rev. #4. February 2.

- ASTM. 2002. ASTM D6771-02 - Standard Practice for Low-Flow Purging and Sampling for Wells and Devices Used for Ground-Water Quality Investigations (Withdrawn 2011). Available at: <https://www.astm.org/Standards/D6771.htm>.
- California State Water Quality Control Board. 2020. Per- and Polyfluoroalkyl Substances (PFAS) Sampling Guidelines for Non-Drinking Water. September. https://www.waterboards.ca.gov/pfas/docs/sept_2020_pfas_sampling_guidelines.pdf
- Department of Environment Regulation (DER). Government of Western Australia. 2016. Interim Guideline on the Assessment and Management of Perfluoroalkyl and Polyfluoroalkyl Substances (PFAS). Contaminated Sites Guidelines. February.
- Michigan Department of Environmental Quality (MDEQ). 2018. General PFAS Sampling Guidance. October. https://www.michigan.gov/documents/pfasresponse/General_PFAS_Sampling_Guidance_634597_7.pdf
- Massachusetts Department of Environmental Protection (MassDEP). 2017. DRAFT Fact Sheet, Guidance on Sampling and Analysis for PFAS at Disposal Sites Regulated under the Massachusetts Contingency Plan. January.
- New Hampshire Department of Environmental Services (NHDES). 2016. Perfluorinated Compound (PFC) Sample Collection Guidance. November.
- United Nations Environment Programme (UNEP). 2015. PFAS analysis in water for the Global Monitoring Plan of the Stockholm Convention, Set-up and guidelines for monitoring. Jana Weiss, Jacob de Boer, Urs Berger, Derek Muir, Ting Ruan, Alejandra Torre, Foppe Smedes, Branislav Vrana, Fabrice Clavient, and Heidelore Fiedler. Division of Technology, Industry and Economics. Geneva. April.
- United States Army Corps of Engineers (USACE). 2016. DRAFT – Standard Operating Procedure 047: Per/Poly Fluorinated Alkyl Substances (PFAS) Field Sampling. Revision: 1. March.
- U.S. Army Corps of Engineers – Omaha District. 2016. Chemistry Requirements – PFAS.
- U.S. Department of Defense (DoD). 2019. Consolidated Quality Systems Manual (QSM) for Environmental Laboratories, Version 5.3. In conjunction with the U.S. Department of Energy. May.
- U.S. Environmental Protection Agency. 2009. USEPA Method 537: Determination of Selected Perfluorinated Alkyl Acids in Drinking Water by Solid Phase Extraction and Liquid Chromatography/Tandem Mass Spectrometry (LC/MS/MS), version 1.1, September. National Exposure Research Laboratory, Office of Research and Development.
- U.S. Environmental Protection Agency. 2010. Low Stress (Low Flow) purging and Sampling Procedure for the Collection of Ground Water Samples from Monitoring Wells. Available at: <https://www.epa.gov/quality/low-stress-low-flow-purging-and-sampling-procedure-collection-groundwater-samples-monitoring>.
- Transport Canada. February 2016, Per-and Polyfluorinated Alkyl Substances (PFAS) Field Sampling Guidance.

Arcadis U.S., Inc.
630 Plaza Drive, Suite 200
Highlands Ranch
Colorado 80129
Phone: 720 344 3500
Fax: 720 344 3535
www.arcadis.com

Attorney-Client Privilege
Attorney Work Product/Prepared at the Direction of Counsel

Appendix C

Soil Boring and Construction Logs; Stantec Preliminary Potentiometric Surface Map



Boring No.: SB-03/MW-03

Soil Boring and Construction Log

Sheet: 1 of 4

Client Name: Norfolk Southern Date Started: 03-05-2023 Logger: Clair Lueke
 Project Number: 30169714 Date Completed: 03-06-2023 Reviewer: Evan Green
 Project Name: East Palestine Train Derailment Total Depth: 72.0 ft bgs

Depth (feet)	Soil Sample ID	Water Sample ID	Rec. (ft)	Screening (ppm)	Blow Counts	Graphic	Description	Drilling Fluid and Notes	Construction Details
1				0.4			Brown Silty fine SAND, little fine Gravel, trace roots, loose, wet [Topsoil and Fill].	(0-5 ft) Boring hand cleared to 5' bgs.	
2							Strong brown fine SAND, trace fine subangular Gravel, trace Organics (roots), hard, dry, non-plastic.		
3									
4				0.4					
5									
6			1	1.4			Strong brown SILT, little fine Sand, trace fine subangular Gravel, mottled, hard, dry, non-plastic, no odor.		
7			1	0.5					
8			1	0.8					
9	SB-03(8-9)/20230305		1	2.7			CLAY, little Silt, little fine Sand, wet, cohesive, soft, low plasticity.		2" PVC Casing
9							Silty fine SAND, cohesive, dense, wet.		
10			1	0.6			Strong brown SILT, little Clay, cohesive, very stiff, dry (moist at 11.5' bgs), low plasticity, no odor.		
11			1	0.4			Brown Silty CLAY, little well rounded Cobble from 14.7 - 16.4' bgs, trace coarse Sand, mottled, cohesive, very stiff, dry, medium plasticity, no odor.		Bentonite-Cement Grout (0-57' bgs).
12			1	0.3					
13				0.4					
14									
15			4	0.3					
16									
17				0.3					
18									
19			4	0.7			Strong brown CLAY, little Silt, trace fine subangular Gravel, cohesive, dry, very stiff, medium plasticity, no odor.		
20									

Drilling Co.: HD Drilling Drilling Method: Rotary Sonic
 Driller: Mike Mchar Sampling Dimensions (ft): 5
 Helper: None First Encountered Water (ft bgs): 8
 Drill Rig: Track-Mounted Rotary Sonic Static Water Level (ft bgs): NA
 Remarks: Horizontal survey in U.S. feet referenced to Ohio State Plane North Zone. Elevations are in U.S. feet referenced to NAVD88. Top of Casing Elev: 1031.54
 Surface Elev: 1028.90
 North Coord: 432320.30
 East Coord: 2515463.59

SOIL BORING AND CONSTRUCTION LOG - C:\USERS\GREENON\DRIVE - ARCADIS\DESKTOP\PROJECTS\CON GOING - MINOR\EAST PALESTINE\PROJECTS\EAST PALESTINE MWS GPJ_GINT DATA TEMPLATE.GDT_3/24/23

Soil Boring and Construction Log

Client Name: Norfolk Southern Date Started: 03-05-2023 Logger: Clair Lueke
 Project Number: 30169714 Date Completed: 03-06-2023 Reviewer: Evan Green
 Project Name: East Palestine Train Derailment Total Depth: 72.0 ft bgs

Depth (feet)	Soil Sample ID	Water Sample ID	Rec. (ft)	Screening (ppm)	Blow Counts	Graphic	Description	Drilling Fluid and Notes	Construction Details
21				0.4			Strong brown CLAY, little Silt, trace fine subangular Gravel, cohesive, dry, very stiff, medium plasticity, no odor.		
22			4						
23				0.5					
24									
25				0.7			Brown CLAY, little Silt, little fine Sand, trace fine subangular Gravel, cohesive, very stiff, dry, medium plasticity, no odor.		
26									
27			4	0.8			Brown CLAY, little Silt, little subrounded Cobble from 26 - 27.4' bgs, trace fine subrounded Gravel, cohesive, very stiff, dry, medium plasticity, no odor.		
28				0.8					
29				0.8					
30				0.5					
31									
32				0.5					
33			4	0.3					
34									
35				0.3					
36									
37				0.5			Weak red Silty fine SAND, little fine well-rounded Gravel, dense, wet, no odor.		
38									
39			4	0.4			Dark reddish brown CLAY, little Silt, little Cobble from 37.3 - 38' bgs, trace coarse Sand, trace subrounded Gravel, hard, dry, medium plasticity, no odor.		
40									
41				0.5					
42									

2" PVC Casing
 Bentonite-Cement Grout (0-57' bgs).

Remarks: Horizontal survey in U.S. feet referenced to Ohio State Plane North Zone. Elevations are in U.S. feet referenced to NAVD88.

Soil Boring and Construction Log

Client Name: Norfolk Southern Date Started: 03-05-2023 Logger: Clair Lueke
 Project Number: 30169714 Date Completed: 03-06-2023 Reviewer: Evan Green
 Project Name: East Palestine Train Derailment Total Depth: 72.0 ft bgs

Depth (feet)	Soil Sample ID	Water Sample ID	Rec. (ft)	Screening (ppm)	Blow Counts	Graphic	Description	Drilling Fluid and Notes	Construction Details
43				0.8			Strong brown CLAY, little Silt, trace fine - coarse Sand, trace subrounded Gravel, cohesive, dry, hard, medium plasticity, no odor.		
44									
45			4	0.7					
46									
47				0.8					
48									
49				0.3					
50									Bentonite-Cemenet Grout (0-57' bgs.)
51			4	0.5					
52								2" PVC Casing	
53				0.3			Brown fine - medium SAND, little fine well-rounded Gravel, dense, moist, no odor.		
54									
55				0.5			SAND, little Silt, trace fine well-rounded Gravel, loose, moist.		
56									
57			4	0.4			Brown Silty CLAY, trace fine well-rounded Gravel, cohesive, hard, dry, no odor.		
58									
59				0.5					Bentonite Seal (57-60' bgs.)
60									
61	SB-03(60-62)/20230306			0.4					
62			4				Brown fine - medium SAND, little Silt, trace fine Gravel, very dense, wet, no odor.		#5 Silica Sand Pack (60-72' bgs.)
63				0.7			Dark yellowish brown Clayey SILT, little coarse Sand, trace fine well-rounded Gravel, cohesive, hard, moist, non-platic, no	2" 0.010 Slot Schedule 40 PVC Screen	
64									

Remarks: Horizontal survey in U.S. feet referenced to Ohio State Plane North Zone. Elevations are in U.S. feet referenced to NAVD88.

Soil Boring and Construction Log

Client Name: Norfolk Southern Date Started: 03-05-2023 Logger: Clair Lueke
 Project Number: 30169714 Date Completed: 03-06-2023 Reviewer: Evan Green
 Project Name: East Palestine Train Derailment Total Depth: 72.0 ft bgs

Depth (feet)	Soil Sample ID	Water Sample ID	Rec. (ft)	Screening (ppm)	Blow Counts	Graphic	Description	Drilling Fluid and Notes	Construction Details
65			4	0.6			odor. Light yellowish brown medium - coarse SAND, little fine well-rounded Gravel, little well-rounded Cobble, loose, wet, no odor.		<p>2" 0.010 Slot Schedule 40 PVC Screen</p> <p>#5 Silica Sand Pack (60-72' bgs.)</p>
66							Brown medium - coarse SAND, loose, wet, no odor.		
67				0.4					
68									
69			4	0.7			Dark yellowish brown Silty CLAY, trace coarse Sand, cohesive, hard, dry, low plasticity, no odor.		
70									
71				0.6					
72							Brown fine - coarse SAND little well-rounded Cobble, loose, wet, no odor.		
							72 ft. bgs End of Boring		PVC Sump
73									
74									
75									
76									
77									
78									
79									
80									
81									
82									
83									
84									
85									
86									

Remarks: Horizontal survey in U.S. feet referenced to Ohio State Plane North Zone. Elevations are in U.S. feet referenced to NAVD88.

SOIL BORING AND CONSTRUCTION LOG - C:\USERS\EGREEN\DRIVE - ARCADIS\DESKTOP\PROJECTS\ON GOING - MINOR\EAST PALESTINE\PROJECTS\EAST PALESTINE MWS GPJ GINT DATA TEMPLATE.GDT 3/24/23

Soil Boring and Construction Log

Client Name: Norfolk Southern Date Started: 03-01-2023 Logger: Clair Lueke
 Project Number: 30169714 Date Completed: 03-02-2023 Reviewer: Evan Green
 Project Name: East Palestine Train Derailment Total Depth: 75.0 ft bgs

Depth (feet)	Soil Sample ID	Water Sample ID	Rec. (ft)	Screening (ppm)	Blow Counts	Graphic	Description	Drilling Fluid and Notes	Construction Details
1				0.3			Dark brown fine SAND, little Organics (roots), loose, moist [Topsoil].	(0-5 ft) Boring hand cleared to 5' bgs.	4" Stainless Steel Protective Casing Sand Drain (0-1' bgs.) 2" PVC Casing Bentonite-Cemenet Grout (0-61' bgs).
2							Brown fine - medium SAND, medium stiff, moist, low plasticity.		
3				0.5					
4							Brown Silty CLAY, little Organics (roots), cohesive, stiff, moist, medium plasticity, no odor.		
5									
6			1	0.7			Brown Silty CLAY, light gray mottling at 2.2' bgs, cohesive, stiff, moist, high plasticity, no odor.		
7	SB-06(6-7)/20230301		1	1.3					
8			1	0.9			Brown Silty fine GRAVEL, little medium - coarse Sand, dense, wet.		
9			1	0.9			Strong brown Silty fine SAND, little sub-rounded Gravel, very dense, wet, no odor.		
10			1	0.4			Brown Silty fine GRAVEL, little coarse Sand, dense, wet, no odor.		
11			1	0.7			Strong brown Silty fine SAND, trace Clay after 10.5' bgs, very dense, dry, no odor.		
12			1	0.7			Brown SILT, some fine sub-rounded Gravel, trace Clay, trace fine Sand, stiff, dry, low plasticity, no odor.		
13			1	0.3			Brown SILT, little Clay, little fine well-rounded Gravel, trace fine Sand, light gray mottling, cohesive, dry, low plasticity.		
14			1	0.5			Brown SILT, little Clay, little fine Sand, little fine well-rounded Gravel, non-cohesive, dry, non-plastic, no odor.		
15			2	0.5					
16									
17			2	0.3					
18									
19			1						
20			5	0.5			Brown CLAY, little Silt, cohesive, soft, moist, high plasticity.		

Drilling Co.: HD Drilling Drilling Method: Rotary Sonic
 Driller: Mike Mchar Sampling Dimensions (ft): 5
 Helper: None First Encountered Water (ft bgs): 7
 Drill Rig: Track-Mounted Rotary Sonic Static Water Level (ft bgs): NA
 Remarks: Horizontal survey in U.S. feet referenced to Ohio State Plane North Zone. Elevations are in U.S. feet referenced to NAVD88. Top of Casing Elev: 1039.22
 Surface Elev: 1036.39
 North Coord: 432333.36
 East Coord: 2515896.13

SOIL BORING AND CONSTRUCTION LOG - C:\USERS\EGREEN\DRIVE - ARCADIS\DESKTOP\PROJECTS\ON GOING - MINOR\EAST PALESTINE\PROJECTS\EAST PALESTINE MWS.GPJ_GINT DATA TEMPLATE.GDT_3/24/23

Soil Boring and Construction Log

Client Name: Norfolk Southern Date Started: 03-01-2023 Logger: Clair Lueke
 Project Number: 30169714 Date Completed: 03-02-2023 Reviewer: Evan Green
 Project Name: East Palestine Train Derailment Total Depth: 75.0 ft bgs

Depth (feet)	Soil Sample ID	Water Sample ID	Rec. (ft)	Screening (ppm)	Blow Counts	Graphic	Description	Drilling Fluid and Notes	Construction Details
21				0.5			Brown SILT, little Clay, little fine sub-rounded Gravel, non-cohesive, dry, non-plastic, no odor.		
22			5				Dark yellowish brown fine SAND, very dense, moist.		
23				0.6			Brown SILT, little Clay, little sub-rounded Gravel, trace fine Sand, non-cohesive, hard, dry, no odor.		
24									
25				0.3					
26									
27			6	0.4					
28									
29				0.9					
30									
31				0.6					
32									
33			6	0.5					
34									
35				0.5					
36									
37				0.7			Brown Silty CLAY, little fine sub-rounded Gravel, trace fine Sand, non-cohesive, hard, dry, non-plastic, no odor.		
38									
39			6	0.2					
40									
41				0.1					
42									

2" PVC Casing

Bentonite-Cement Grout (0-61' bgs).

Remarks: Horizontal survey in U.S. feet referenced to Ohio State Plane North Zone. Elevations are in U.S. feet referenced to NAVD88.

Soil Boring and Construction Log

Client Name: Norfolk Southern Date Started: 03-01-2023 Logger: Clair Lueke
 Project Number: 30169714 Date Completed: 03-02-2023 Reviewer: Evan Green
 Project Name: East Palestine Train Derailment Total Depth: 75.0 ft bgs

Depth (feet)	Soil Sample ID	Water Sample ID	Rec. (ft)	Screening (ppm)	Blow Counts	Graphic	Description	Drilling Fluid and Notes	Construction Details
43				0.4			Brown Silty CLAY, trace fine sub-rounded - sub-angular Gravel, cohesive, hard, dry, medium plasticity.		
44									
45			6	0.4					
46									
47				0.3			Brown - strong brown SILT, little Clay, trace fine Sand, trace fine sub-rounded Gravel, non-cohesive, hard, dry, low - medium plasticity, dry, no odor.		
48									
49				0.5					
50									
51			6	0.5					
52									
53				0.6					
54									
55				0.5					
56									
57			6	0.4					
58									
59				0.4					
60									
61	SB-06(60-62)/20230302			0.3					
62			6						
63				0.2					
64							Brown fine - medium SAND, trace fine well-rounded Gravel, dense, wet, no odor.		

2" PVC Casing

Bentonite-Cemenet Grout (0-61' bgs.)

Bentonite Seal (61-63' bgs.)

#5 Silica Sand Pack (63-75' bgs.)

Remarks: Horizontal survey in U.S. feet referenced to Ohio State Plane North Zone. Elevations are in U.S. feet referenced to NAVD88.

Soil Boring and Construction Log

Client Name: Norfolk Southern Date Started: 03-01-2023 Logger: Clair Lueke
 Project Number: 30169714 Date Completed: 03-02-2023 Reviewer: Evan Green
 Project Name: East Palestine Train Derailment Total Depth: 75.0 ft bgs

Depth (feet)	Soil Sample ID	Water Sample ID	Rec. (ft)	Screening (ppm)	Blow Counts	Graphic	Description	Drilling Fluid and Notes	Construction Details
65			6	0.2			Brown fine - coarse SAND, loose, wet, no odor.		2" PVC Casing
66							Brown coarse SAND, little - some Gravel, little Silt, loose, wet, no odor.		
67			6	0.2			Brown CLAY, little Silt, trace - little fine well-rounded Gravel, very stiff, dry, medium plasticity, no odor.		2" 0.010 Slot Schedule 40 PVC Screen
68							Brown fine - medium SAND, dense, wet, no odor.		
69			6	0.2			Brown medium - coarse SAND, trace fine well-rounded Gravel, loose, wet, no odor.		#5 Silica Sand Pack (63-75' bgs.)
70							Dark grayish brown CLAY, little Silt, trace - little fine well-rounded Gravel, hard, dry, medium plasticity, no odor.		
71			3	0.3			Brown fine - coarse GRAVEL, trace fine - coarse Sand, very loose, wet, no odor.		PVC Sump
72							Brown fine - coarse SAND, little Silt, trace well-rounded Gravel, loose, wet, no odor.		
73			3	0.3			Dark grayish brown CLAY, little Silt, trace fine well-rounded Gravel, hard, dry, medium plasticity, no odor.		
74							75 ft. bgs End of Boring		
75									
76									
77									
78									
79									
80									
81									
82									
83									
84									
85									
86									

Remarks: Horizontal survey in U.S. feet referenced to Ohio State Plane North Zone. Elevations are in U.S. feet referenced to NAVD88.

SOIL BORING AND CONSTRUCTION LOG - C:\USERS\EGREEN\ONEDRIVE - ARCADIS\DESKTOP\PROJECTS\ON GOING - MINOR\EAST PALESTINE\PROJECTS\EAST PALESTINE MWS.GPJ - GINT DATA TEMPLATE.GDT - 3/24/23

Soil Boring and Construction Log

Client Name: Norfolk Southern Date Started: 03-03-2023 Logger: Clair Lueke
 Project Number: 30169714 Date Completed: 03-04-2023 Reviewer: Evan Green
 Project Name: East Palestine Train Derailment Total Depth: 74.0 ft bgs

Depth (feet)	Soil Sample ID	Water Sample ID	Rec. (ft)	Screening (ppm)	Blow Counts	Graphic	Description	Drilling Fluid and Notes	Construction Details 4" Stainless Steel Protective Casing
1				0.3			Very dark brown Silty fine SAND, trace Organics (roots), trace rail road ballast, moist, loose [Topsoil and Fill].	(0-5 ft) Boring hand cleared to 5' bgs.	Sand Drain (0-1' bgs.)
2							Brown SILT, little fine Sand, trace Clay, non-cohesive, dry - moist, non-plastic, no odor.		
3							Brown Silty CLAY, cohesive, light gray mottling after 5.5' bgs, hard, dry - moist, high plasticity, no odor.		
4				0.2			Brown Silty CLAY, cohesive, light gray mottling after 5.5' bgs, hard, dry - moist, high plasticity, no odor.		
5							Brown Silty CLAY, cohesive, light gray mottling after 5.5' bgs, hard, dry - moist, high plasticity, no odor.		
6	SB-08/5-6/20230303		1	1			Brown Silty CLAY, cohesive, light gray mottling after 5.5' bgs, hard, dry - moist, high plasticity, no odor.		
7			1	0.4			Brown Silty CLAY, cohesive, light gray mottling after 5.5' bgs, hard, dry - moist, high plasticity, no odor.		
8			1	0.5			Strong brown SILT, little Clay, trace fine sub-rounded Gravel, non-cohesive, stiff, dry, no odor.		
9			1	0.6			Strong brown Silty CLAY, cohesive, very stiff, dry, medium plasticity, no odor.		
10			1	0.4			Strong brown Silty CLAY, cohesive, very stiff, dry, medium plasticity, no odor.		
11			0	0.2			Limestone boulder. No Recovery.		
12			1	0.2			Strong brown Clayey SILT, trace fine Sand, non-cohesive, hard, dry, moist at 11.5' bgs, low plasticity.		
13			1	0.2			Strong brown Silty fine GRAVEL, little medium - coarse Sand, dense, wet, no odor.		
14			1	0.3			Strong brown CLAY, little Silt, trace coarse Sand, dense, wet, no odor.		
15							Strong brown Silty fine GRAVEL, little medium - coarse Sand, dense, wet, no odor.		
16				0.3			Red SILT, little Clay, cohesive, very stiff, dry, low plasticity, no odor.		
17			4	0.4			Dark grayish brown CLAY, trace intermittent Cobble, trace Silt, trace fine well-rounded Gravel, cohesive, dry, high plasticity, no odor.		
18							Dark grayish brown CLAY, trace intermittent Cobble, trace Silt, trace fine well-rounded Gravel, cohesive, dry, high plasticity, no odor.		
19				0.3			Dark grayish brown CLAY, trace intermittent Cobble, trace Silt, trace fine well-rounded Gravel, cohesive, dry, high plasticity, no odor.		
20							Dark grayish brown CLAY, trace intermittent Cobble, trace Silt, trace fine well-rounded Gravel, cohesive, dry, high plasticity, no odor.		Bentonite-Cemenet Grout (1-58' bgs).

Drilling Co.: HD Drilling Drilling Method: Rotary Sonic
 Driller: Mike Mchar Sampling Dimensions (ft): 5
 Helper: None First Encountered Water (ft bgs): 11.7
 Drill Rig: Track-Mounted Rotary Sonic Static Water Level (ft bgs): NA
 Remarks: Horizontal survey in U.S. feet referenced to Ohio State Plane North Zone. Elevations are in U.S. feet referenced to NAVD88. Top of Casing Elev: 1041.72
 Surface Elev: 1039.06
 North Coord: 432327.04
 East Coord: 2516013.78

SOIL BORING AND CONSTRUCTION LOG - C:\USERS\EGREEN\ONEDRIVE - ARCADIS\DESKTOP\PROJECTS\CON GOING - MINOR\EA\PALESTINE\MWS\GPI\GINT DATA TEMPLATE.GDT 3/24/23

Soil Boring and Construction Log

Client Name: Norfolk Southern Date Started: 03-03-2023 Logger: Clair Lueke
 Project Number: 30169714 Date Completed: 03-04-2023 Reviewer: Evan Green
 Project Name: East Palestine Train Derailment Total Depth: 74.0 ft bgs

Depth (feet)	Soil Sample ID	Water Sample ID	Rec. (ft)	Screening (ppm)	Blow Counts	Graphic	Description	Drilling Fluid and Notes	Construction Details
21				0.3			Dark grayish brown CLAY, trace intermittent Cobble, trace Silt, trace fine well-rounded Gravel, cohesive, dry, high plasticity, no odor.		
22									
23			6	0.3					
24									
25				0.4					
26									
27				0.5					
28									
29			6	0.3					
30									
31				0.4			Brown CLAY, trace Silt, trace fine sub-rounded Gravel, cohesive, hard, dry, high plasticity, no odor.		
32									
33				0.6					
34									
35			6	0.3					
36									
37				0.5					
38									
39				0.4					
40			6						
41				0.5					
42									

Bentonite-Cement Grout (1-58' bgs).

Remarks: Horizontal survey in U.S. feet referenced to Ohio State Plane North Zone. Elevations are in U.S. feet referenced to NAVD88.

Soil Boring and Construction Log

Client Name: Norfolk Southern Date Started: 03-03-2023 Logger: Clair Lueke
 Project Number: 30169714 Date Completed: 03-04-2023 Reviewer: Evan Green
 Project Name: East Palestine Train Derailment Total Depth: 74.0 ft bgs

Depth (feet)	Soil Sample ID	Water Sample ID	Rec. (ft)	Screening (ppm)	Blow Counts	Graphic	Description	Drilling Fluid and Notes	Construction Details
43			6	0.4			Brown CLAY, trace Silt, trace fine sub-rounded Gravel, cohesive, hard, dry, high plasticity, no odor.		
44									
45				0					
46									
47			6	0			Brown fine - medium SAND, dense, moist, no odor.		
48							Brown CLAY, little Silt, trace fine sub-rounded Gravel, trace coarse Sand, cohesive, very stiff, dry, medium plasticity, no odor.		
49				0					
50									
51				0					
52									
53			6	0					
54									
55				0					
56									
57				0					
58									
59			6	0					
60									
61	SB-08(60-62)/20230304			0					
62									
63			6	0			Grayish brown Silty CLAY, little fine Sand, little fine Gravel, cohesive, hard, wet, non-plastic, no odor.		
64									

Bentonite-Cement Grout (1-58' bgs.)

Bentonite Seal (58-60' bgs.)

#5 Silica Sand Pack (60-72' bgs.)

2" 0.020 Slot Schedule 40 PVC Screen

 Remarks: Horizontal survey in U.S. feet referenced to Ohio State Plane North Zone. Elevations are in U.S. feet referenced to NAVD88.

Soil Boring and Construction Log

Client Name: Norfolk Southern Date Started: 03-03-2023 Logger: Clair Lueke
 Project Number: 30169714 Date Completed: 03-04-2023 Reviewer: Evan Green
 Project Name: East Palestine Train Derailment Total Depth: 74.0 ft bgs

Depth (feet)	Soil Sample ID	Water Sample ID	Rec. (ft)	Screening (ppm)	Blow Counts	Graphic	Description	Drilling Fluid and Notes	Construction Details
65				0			Brown CLAY, little Silt, little fine Sand, trace sub-rounded Gravel, cohesive, hard, dry, no odor.		
66			6			Brown fine - medium SAND, trace fine well-rounded Gravel, loose, wet, no odor.			
67				0			Brown fine - coarse SAND, loose, wet, no odor.		
68							Brown fine - coarse SAND, loose, wet, no odor.		
69				0			Light brown fine - coarse SAND, trace fine sub-rounded Gravel, loose, wet.		
70							Light brown fine - coarse SAND, trace fine sub-rounded Gravel, loose, wet.		
71			6	0			Brown Silty CLAY, trace coarse Sand, cohesive, hard, dry, medium plasticity.		
72							Brown medium - coarse SAND, little fine well-rounded Gravel, loose, wet, no odor.		
73									
74									

74 ft. bgs End of Boring

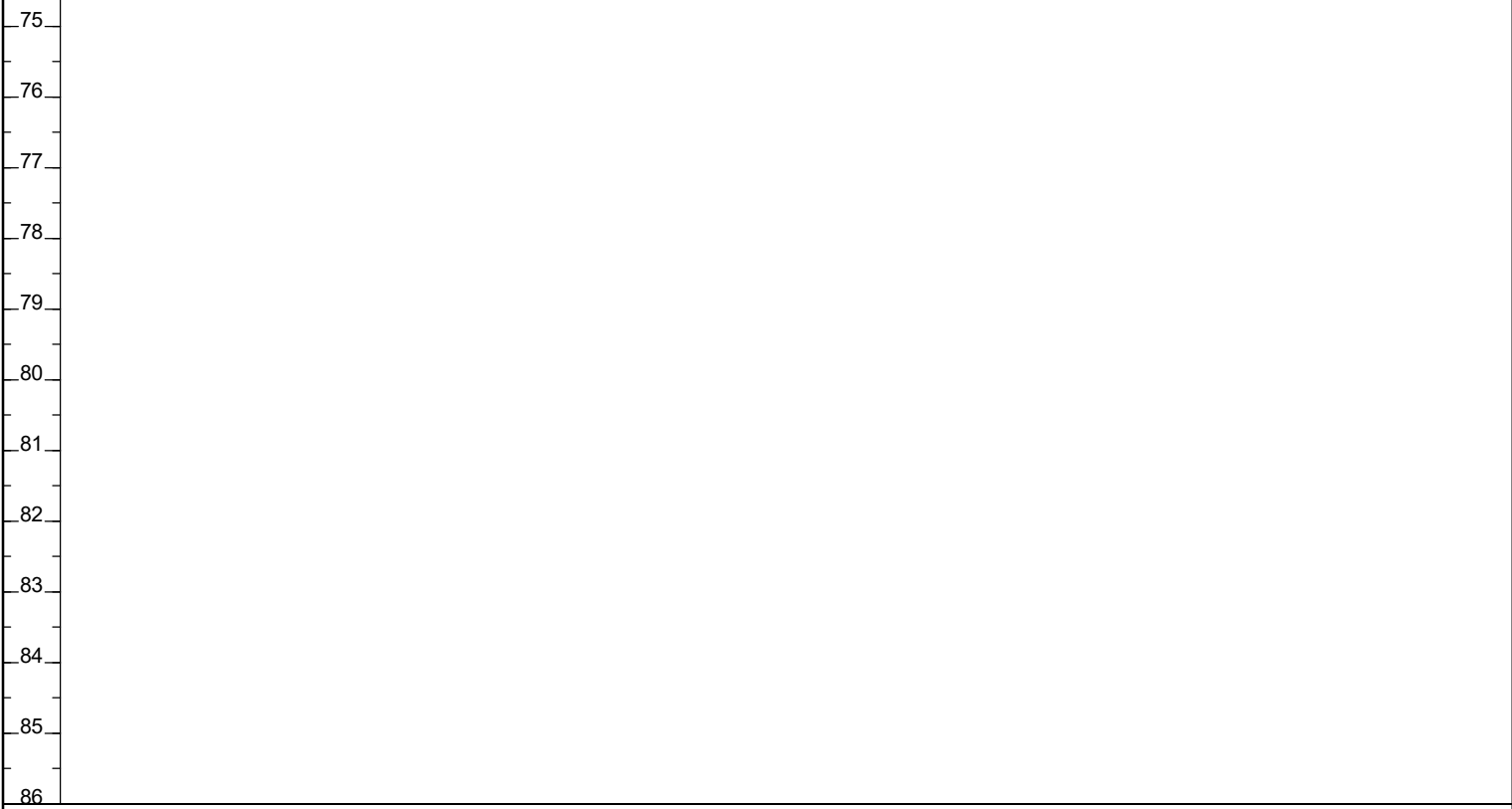

Remarks: Horizontal survey in U.S. feet referenced to Ohio State Plane North Zone. Elevations are in U.S. feet referenced to NAVD88.

SOIL BORING AND CONSTRUCTION LOG - C:\USERS\EGREEN\ONEDRIVE - ARCADIS\DESKTOP\PROJECTS\ON GOING - MINOR\EAST PALESTINE\PROJECTS\EAST PALESTINE MWS.GPJ - GINT DATA TEMPLATE.GDT - 3/24/23

Soil Boring and Construction Log

Client Name: Norfolk Southern Date Started: 02-25-2023 Logger: Clair Lueke
 Project Number: 30169714 Date Completed: 02-27-2023 Reviewer: Evan Green
 Project Name: East Palestine Train Derailment Total Depth: 62.0 ft bgs

Depth (feet)	Soil Sample ID	Water Sample ID	Rec. (ft)	Screening (ppm)	Blow Counts	Graphic	Description	Drilling Fluid and Notes	Construction Details 4" Stainless Steel Protective Casing
1				0.5			Black coarse GRAVEL, some fine - coarse Sand, loose, dry, no odor [Railroad Ballast and Fill].	(0-5 ft) Boring hand cleared to 5' bgs.	
2				0.1		Strong brown Silty CLAY, little coarse Gravel, trace - little fine Sand, cohesive, stiff, dry, low plasticity, no odor.			
3				0.5					
4				0.3			Strong brown fine SAND, little Silt, dense, wet at 4.5' bgs, no odor.		
5			1	1.3					
6	SB-10(5-6)/20230225		1	0.5			Strong brown Silty fine SAND, little fine - medium subangular Gravel, light gray mottling, dense, moist, no odor.		
7			1	0.7					
8			1	1.2			Dark gray Silty CLAY, cohesive, stiff, moist, medium - high plasticity, no odor.		
9			1	0.4			Dark gray Silty CLAY, cohesive, moist - wet, medium - high plasticity, no odor.		
10			1	0.4			Strong brown Clayey SILT, trace - little fine Sand, trace fine well-rounded Gravel, cohesive, stiff, wet, low plasticity, no odor.		
11							Sandy SILT, trace Clay, trace fine well-rounded Gravel, soft, wet, no odor.		
12				0.5			Dark grayish brown Silty CLAY, trace - little well-rounded Gravel, cohesive, very stiff, dry, high plasticity, no odor.		
13			5						
14				0.5					
15									
16				0.5					
17							Dark grayish brown CLAY, little Silt, trace fine - medium sub-rounded - angular Gravel, cohesive, very stiff, moist, high plasticity, no odor.		
18			4	0.6					
19									
20				0.4					

Drilling Co.: HD Drilling Drilling Method: Rotary Sonic
 Driller: Mike Mchar Sampling Dimensions (ft): 5
 Helper: None First Encountered Water (ft bgs): 4.5
 Drill Rig: Track-Mounted Rotary Sonic Static Water Level (ft bgs): NA
 Remarks: Horizontal survey in U.S. feet referenced to Ohio State Plane North Zone. Elevations are in U.S. feet referenced to NAVD88. Top of Casing Elev: 1020.80
 Surface Elev: 1018.01
 North Coord: 432008.13
 East Coord: 2513403.23

SOIL BORING AND CONSTRUCTION LOG - C:\USERS\GREENON\DRIVE - ARCADIS\DESKTOP\PROJECTS\CON GOING - MINOR\EA ST PALESTINE\PROJECTS\EA ST PALESTINE MWS GPJ GINT DATA TEMPLATE.GDT 3/24/23

Soil Boring and Construction Log

Client Name: Norfolk Southern Date Started: 02-25-2023 Logger: Clair Lueke
 Project Number: 30169714 Date Completed: 02-27-2023 Reviewer: Evan Green
 Project Name: East Palestine Train Derailment Total Depth: 62.0 ft bgs

Depth (feet)	Soil Sample ID	Water Sample ID	Rec. (ft)	Screening (ppm)	Blow Counts	Graphic	Description	Drilling Fluid and Notes	Construction Details				
21				0.4			Dark grayish brown CLAY, little Silt, trace fine - medium sub-rounded - angular Gravel, cohesive, very stiff, moist, high plasticity, no odor.						
22				0.4									
23			5										
24				0.5									
25													
26				0.4							Brown CLAY, little Silt, little fine Gravel, well-rounded Cobble at 31.4' bgs, cohesive, very stiff, dry - moist, medium - high plasticity, no odor.		
27													
28			5										
29				0.5									
30				0.4									
31													
32				0.7									
33			5										
34				0.5									
35													
36				0.5			Dusky red CLAY, little Silt, little fine Sand, trace - little fine subangular Gravel, in creasing Clay content with depth, cohesive, stiff, medium Plasticity, no odor.						
37													
38			5										
39				0.8									
40													
41				0.6									
42			5										
				0.5									
											Dusky red Silty CLAY, fine Sand at 41.2' bgs, cohesive, stiff, dry, medium - high plasticity.		

Bentonite-Cemenet Grout (1-58' bgs).

Remarks: Horizontal survey in U.S. feet referenced to Ohio State Plane North Zone. Elevations are in U.S. feet referenced to NAVD88.

SOIL BORING AND CONSTRUCTION LOG - C:\USERS\EGREEN\ONEDRIVE - ARCADIS\DESKTOP\PROJECTS\GOING - MINOR\EAST PALESTINE\PROJECTS\EAST PALESTINE MWS.GPJ_GINT DATA TEMPLATE.GDT 3/24/23

Soil Boring and Construction Log

Client Name: Norfolk Southern Date Started: 02-25-2023 Logger: Clair Lueke
 Project Number: 30169714 Date Completed: 02-27-2023 Reviewer: Evan Green
 Project Name: East Palestine Train Derailment Total Depth: 62.0 ft bgs

Depth (feet)	Soil Sample ID	Water Sample ID	Rec. (ft)	Screening (ppm)	Blow Counts	Graphic	Description	Drilling Fluid and Notes	Construction Details	
43			5	0.5			Dark yellowish brown fine - coarse SAND, little well-rounded Gravel, light gray motteling after 43.2' bgs, loose, dry - moist, no odor.			
44		0.5								
45			5	0.7			Dark grayish brown Silty CLAY, trace - little fine - coarse Gravel, trace - little Cobble, dry, medium plasticity, no odor.			
46										
47			5	0.9			Light gray LIMESTONE Boulder, fine-grained.			
48										
49			3	0.6			Brown fine - coarse SAND, little Silt, trace - little fine well-rounded Gravel, loose, wet, no odor.			
50										
51	SB-10(50.5-51.5)/20230227		3	0.8			Brown fine - coarse SAND, loose, wet.			
52										
53			3	0.8			Brown fine - coarse SAND, loose, wet, no odor.			
54										
55			3.5	0.4			Brown fine - coarse SAND, trace - little fine well-rounded Gravel, trace - little Silt, loose, wet, no odor.			
56										
57			3.5	0.4			Dark gray fine GRAVEL and medium - coarse SAND, dense, wet, no odor.			
58										
59			3.5	0.4			Brown medium - coarse SAND, trace - little fine rounded Gravel, increasing grain size with depth, dense, wet, no odor.			
60										
61			3.5	0.4			Brown fine - coarse GRAVEL, loose, wet, no odor.			
62										
							62 ft. bgs End of Boring			
63										
64										

Remarks: Horizontal survey in U.S. feet referenced to Ohio State Plane North Zone. Elevations are in U.S. feet referenced to NAVD88.

PROJECT: **NSRC - East Palestine Derailment**
 LOCATION: **East Palestine, OH**
 PROJECT NUMBER: **172607922**

WELL / PROBEHOLE / BOREHOLE NO

SMW-05 PAGE 1 OF 1



DRILLING / INSTALLATION:
 STARTED **2/19/23** COMPLETED: **2/19/23**
 DRILLING COMPANY: **Stantec Drilling**
 DRILLING EQUIPMENT: **TBD**
 DRILLING METHOD: **Hollow Stem Auger**
 SAMPLING EQUIPMENT: **4.25" Hollow Stem Auger**

NORTHING (ft): **432,046.38** EASTING (ft): **2,516,432.89**
 LAT: LONG:
 GROUND ELEV (ft): TOC ELEV (ft): **1037.72**
 INITIAL DTW (ft): **Not Encountered** WELL DEPTH (ft): **39.8**
 STATIC DTW (ft): **Not Encountered** BOREHOLE DEPTH (ft): **40.0**
 WELL CASING DIA. (in): **2** BOREHOLE DIA. (in): **8.25**
 LOGGED BY: **J. Bacon** CHECKED BY: **J. Griggs**

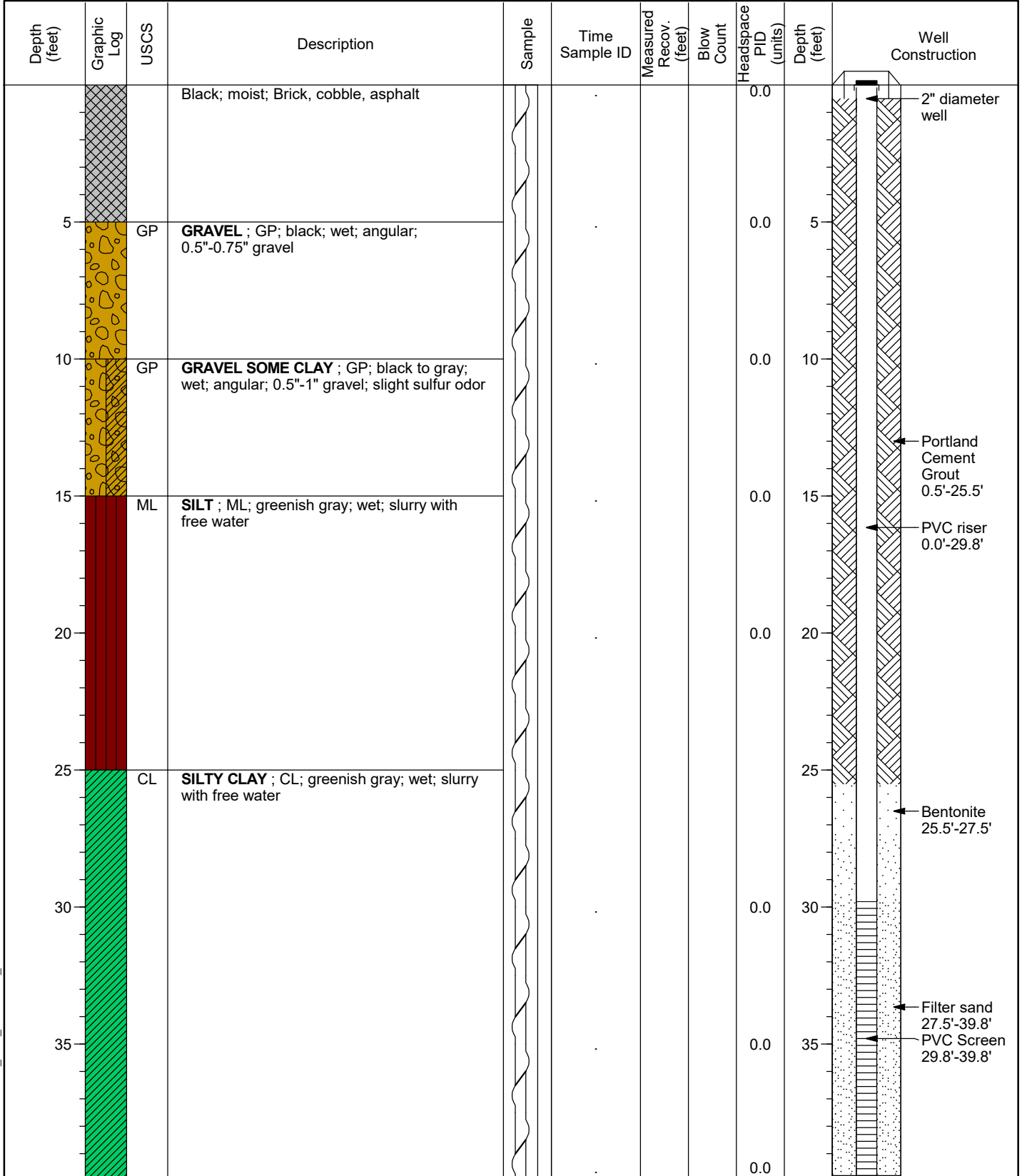

GEO FORM 304 LOG_NFS_SENTINEL_MW.GPJ STANTEC ENVIRO TEMPLATE 010509.GDT 3/22/23

Borehole terminated at 40 feet.

PROJECT: **NSRC - East Palestine Derailment**
 LOCATION: **East Palestine, OH**
 PROJECT NUMBER: **172607922**

WELL / PROBEHOLE / BOREHOLE NO

SB-06/SMW-06 PAGE 1 OF 4



DRILLING / INSTALLATION:
 STARTED **3/11/23** COMPLETED: **3/12/23**
 DRILLING COMPANY: **HD Drilling**
 DRILLING EQUIPMENT: **TBD**
 DRILLING METHOD: **Roto-Sonic**
 SAMPLING EQUIPMENT: **Roto-Sonic**

NORTHING (ft): **432,120.39** EASTING (ft): **2,516,304.83**
 LAT: LONG:
 GROUND ELEV (ft): TOC ELEV (ft): **1038.00**
 INITIAL DTW (ft): **Not Encountered** WELL DEPTH (ft): **78.0**
 STATIC DTW (ft): **Not Encountered** BOREHOLE DEPTH (ft): **78.0**
 WELL CASING DIA. (in): **2** BOREHOLE DIA. (in): **6.25**
 LOGGED BY: **K. Miller** CHECKED BY: **J. Griggs**

Depth (feet)	Graphic Log	USCS	Description	Sample	Time Sample ID	Measured Recov. (feet)	Blow Count	Headspace PID (units)	Depth (feet)	Well Construction
			SAND TRACE SILT ; 7.5YR 2.5/3 dark brown; medium to coarse-grained; loose; dry; (Fill)							2" diameter well
			No Recovery			1.5/5		6.1		PVC riser 0.0'-68'
5			SAND TRACE SILT ; 7.5YR 2.5/3 dark brown; medium to coarse-grained; loose; dry; brick fragment at 5.4'; (Fill)			1/1		0.6	5	
			SAND ; 5YR 2.5/1 black; medium to coarse-grained; loose; wet; slight odor; trace light gray nodules; (Fill)			1/1		0.7		
			SAND LITTLE FINE GRAVEL ; 5YR 2.5/1 black; medium to coarse-grained; loose; wet; angular; slight odor; (Fill)			1/1		0.5		
		ML	SILT SOME CLAY ; ML; 10YR 4/2 very dark grayish brown; cohesive; low plasticity; soft; wet; no odor			1/1		1.2		
10			SAND LITTLE FINE GRAVEL ; 5YR 2.5/1 black; medium to coarse-grained; loose; wet; angular; slight odor; (Fill)			1/1		0.8	10	
			Wood fragments 10.7'-11.0'			1/1		0.7		
								0.9		
		CL	SILTY CLAY LITTLE FINE SAND TRACE ROOTS ; CL; 7.5YR 3/3 dark brown; cohesive; medium plasticity; very stiff; moist			1/1		0.6		
		ML	SILT LITTLE FINE SAND LITTLE CLAY ; ML; 10YR 6/1 gray; non-cohesive; low plasticity; hard; dry; no odor			1/1		0.6		
		CL	CLAY TRACE SILT ; CL; 10YR 6/1 gray; cohesive; medium plasticity; very stiff; dry			1/1		0.6		
15		CL	CL; 10YR 4/4 dark yellowish brown to light gray; mottled; 13.3' to 14.0'					0.4	15	
		CL	CL; 5YR 8/6 yellow; loose; dry; small pockets of sand 13.4' to 14.0'							
		CH	CLAY WITH SILT TRACE FINE GRAVEL ; CL; 10YR 4/4 dark yellowish brown; cohesive; medium plasticity; very stiff; dry; subangular; light gray mottling 14.7' to 15.0'			4/6		0.8		
			CLAY TRACE FINE GRAVEL ; CH; 10YR 4/2 dark grayish brown; cohesive; high plasticity; stiff; dry; no odor; small pocket of fine sand, loose, dry, yellow (10YR 7/8)							
			No Recovery							

GEO FORM 304 LOG_NFS_SENTINEL_MW.GPJ STANTEC ENVIRO TEMPLATE 010509.GDT 3/22/23

\\corp.adis\data\Virtual_Workspace\shared_projects\Spill_Response\172607922\gis_cad\gis\proj\norfolk\southern\norfolksouthern.aprx Revised: 2023-04-27 By: kberglund

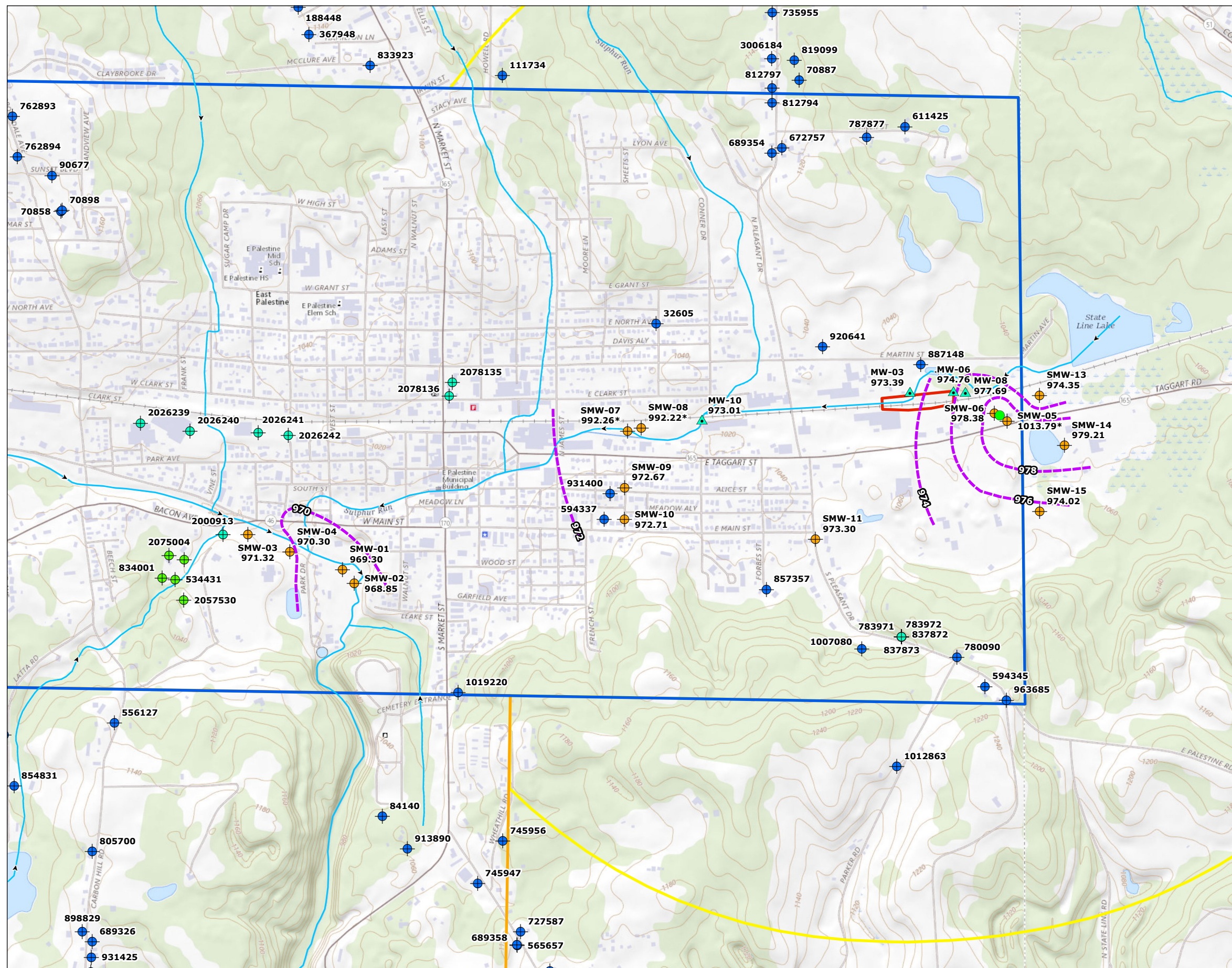
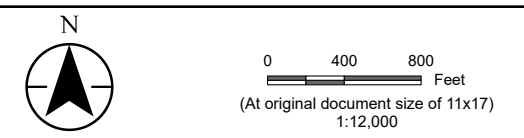

Figure No. **3**
Title **Preliminary Potentiometric Surface Map - April 19, 2023**

Client/Project **Norfolk Southern** 172607922

Project Location **East Palestine, Columbiana Co., OH** Prepared by KB on 2023-04-27



- Incident Area
- Priority Sampling Zones**
- Priority Zone 1
- Priority Zone 2
- Priority Zone 3
- ◆ Sentinel Wells
- ▲ On-Site Monitoring Well
- Transient PWS Supply Well
- Public Water Supply
- ODNR Wells**
- ◆ ODNR Classified Monitoring Well
- ◆ ODNR Classified Domestic Well
- Streams
- Groundwater Contour (2ft Interval)

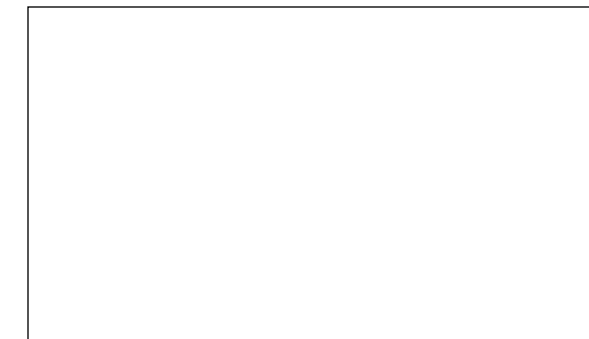

Notes
1. Coordinate System: NAD 1983 UTM Zone 17N
2. Data Sources: USGS, Ohio Department of Natural Resources
3. Background: USGS 7.5 Minute Quadrangle
*Groundwater elevation shown but not used for contouring



Arcadis U.S., Inc.
7575 Huntington Park Drive, Suite 130
Columbus
Ohio 43235
Phone: 614 985 9100
Fax: 614 985 9170
www.arcadis.com