



DEPARTMENT ORDER

IN THE MATTER OF

ANDROSCOGGIN RESERVOIR COMPANY)	MAINE POLLUTANT DISCHARGE
LINCOLN PLANTATION,)	ELIMINATION SYSTEM PERMIT
OXFORD CO., MAINE)	
COOLING WATER DISCHARGE)	AND
AZISCOHOS HYDRO PROJECT)	
#ME0036722)	WASTE DISCHARGE LICENSE
#W007582-5R-H-R)	RENEWAL
APPROVAL)	

In compliance with the applicable provisions of *Pollution Control*, 38 M.R.S. §411 – 424-B, *Water Classification Program*, 38 M.R.S. §464 – 470 and *Federal Water Pollution Control Act*, Title 33 U.S.C. §1251, and applicable rules of the Department of Environmental Protection (Department), the Department has considered the application of ANDROSCOGGIN RESERVOIR COMPANY (ARCo), with its supportive data, agency review comments, and other related materials on file, and FINDS THE FOLLOWING FACTS:

APPLICATION SUMMARY

ARCo has submitted a timely and complete application to the Department for renewal of combination Maine Pollutant Discharge Elimination System (MEPDES) permit #ME0036722/Waste Discharge License (WDL) #W007582-5R-F-R, which was issued by the Department on March 17, 2014 for a five-year term. The 3/17/14 permit authorized the daily discharge of 270,000 gallons per day of non-contact cooling water and miscellaneous facility drainage from four outfalls at ARCo's Aziscohos Hydro Project to the Magalloway River, Class A, in Lincoln Plantation, Maine.

PERMIT SUMMARY

This permitting action carries forward all the terms and conditions established in the previous permit.

CONCLUSIONS

BASED on the findings in the attached Fact Sheet dated August 11, 2023, and subject to the Conditions listed below, the Department makes the following conclusions:

1. The discharge, either by itself or in combination with other discharges, will not lower the quality of any classified body of water below such classification.
2. The discharge, either by itself or in combination with other discharges, will not lower the quality of any unclassified body of water below the classification which the Department expects to adopt in accordance with state law.
3. The provisions of the State's antidegradation policy, 38 M.R.S. §464(4)(F), will be met, in that:
 - (a) Existing in-stream water uses and the level of water quality necessary to protect and maintain those existing uses will be maintained and protected;
 - (b) Where high quality waters of the State constitute an outstanding national resource, that water quality will be maintained and protected;
 - (c) Where the standards of classification of the receiving water body are met or, where the standards of classification of the receiving water body are not met, the discharge will not cause or contribute to the failure of the water body to meet the standards of classification;
 - (d) Where the actual quality of any classified receiving water body exceeds the minimum standards of the next highest classification, that higher water quality will be maintained and protected; and
 - (e) Where a discharge will result in lowering the existing quality of any water body, the Department has made the finding, following opportunity for public participation, that this action is necessary to achieve important economic or social benefits to the State.
4. The discharge will be subject to effluent limitations that require application of best practicable treatment as defined in 38 M.R.S. §414-A(1)(D).
5. The applicant has objectively demonstrated to the Department's satisfaction that the discharge is necessary and that there are no other reasonable alternatives available, as required by *Standards for classification of fresh surface waters*, 38 M.R.S. §465(2) for the discharge to Class A water.

ACTION

THEREFORE, the Department APPROVES the application of ANDROSCOGGIN RESERVOIR COMPANY'S, to discharge 270,000 gallons per day of non-contact cooling water from two outfalls (#001 and #004) and an unspecified quantity of miscellaneous facility drainage from two additional outfalls (#002 and #003) at a temperature not to exceed 95 degrees Fahrenheit from the Aziscohos Hydro Project to the Magalloway River, Class A, SUBJECT TO THE FOLLOWING CONDITIONS, and all applicable standards and regulations including:

1. "Maine Pollutant Discharge Elimination System Permit Standard Conditions Applicable To All Permits," revised July 1, 2002, copy attached.
2. The attached Special Conditions, including any effluent limitations and monitoring requirements.
3. This permit and the authorization to discharge become effective upon the date of signature below and expire at midnight five (5) years from the effective date. If a renewal application is timely submitted and accepted as complete for processing prior to the expiration of this permit, the authorization to discharge and the terms and conditions of this permit and all modifications and minor revisions thereto remain in effect until a final Department decision on the renewal application becomes effective. [*Maine Administrative Procedure Act*, 5 M.R.S. §10002 and *Rules Concerning the Processing of Applications and Other Administrative Matters*, 06-096 CMR 2(21)(A) (last amended June 9, 2018)].

PLEASE NOTE ATTACHED SHEET FOR GUIDANCE ON APPEAL PROCEDURES

DONE AND DATED AT AUGUSTA, MAINE, THIS ____ DAY OF _____, 2023.

DEPARTMENT OF ENVIRONMENTAL PROTECTION

BY: _____
Melanie Loyzim, Commissioner

Date of initial receipt of application: March 21, 2023
Date of application acceptance: March 31, 2023.

Date filed with Board of Environmental Protection:

Filed
March 9, 2023
State of Maine
Board of Environmental
Protection

This Order prepared by Rod Robert, Bureau of Water Quality

SPECIAL CONDITIONS

A. EFFLUENT LIMITATIONS AND MONITORING REQUIREMENTS

1. The discharge of non-contact cooling water is limited to a flow of 270,000 gallons per day and a daily maximum temperature of 95°F.
2. The permittee must not discharge wastewater that contains a visible oil sheen, foam, or floating solids at any time that would impair the designated uses or habitat characteristics of the receiving waters or would otherwise lower the quality of the receiving water below its assigned classification.
3. The permittee must not discharge wastewater that imparts color, taste, turbidity, toxicity, or other properties that would impair the designated uses or habitat characteristics of the receiving waters or would otherwise lower the quality of the receiving water below its assigned classification.
4. The permittee must notify the Department immediately of the discharge of any pollutants other than heat from the facility. The permittee must also notify the Department of any changes in facility design, operation or generating capacity that may affect the flow or temperature of the cooling water discharge.
5. All miscellaneous facility leakage and lubrication waters that may become contaminated with oil or grease are subject to Best Management Practices (BMPs) designed to prevent the release of contaminants to the waters of the State. The permittee must develop BMPs and must make the BMPs available in writing for the Department to review and comment upon request. BMPs must consist of, but not be limited to, the following, as appropriate: development and implementation of a spill prevention plan; use of oil absorbent pads or booms and/or physical berms to contain spills or leaks of hydraulic and lubrication oils; and the treatment of water collected in floor drains and sumps through an oil/grease trap or oil-water separator. Where bearing cooling water is used, BMPs must include the maintenance of a written log or record of bearing oil levels and maintenance activities. Where floor drains and sumps are used, BMPs must include (1) written procedures for the cleaning and maintenance of any oil-grease trap, oil skimmer or oil-water separator and (2) maintenance of a written log or record of visual inspections of sumps for oil and grease and of actions taken to prevent the discharge of oil or grease from the facility.

SPECIAL CONDITIONS

B. AUTHORIZED DISCHARGES

The permittee is authorized to discharge only in accordance with: 1) the permittee's General Application for Waste Discharge Permit, accepted for processing on March 31, 2023; 2) the terms and conditions of this permit; and 3) only from the four outfalls listed on the application. Discharges of wastewater from any other point source are not authorized under this permit, and shall be reported in accordance with Standard Condition D(1)(f), *Twenty-four hour reporting*, of this permit.

C. NOTIFICATION REQUIREMENT

In accordance with Standard Condition D, the permittee shall notify the Department of any substantial change in the volume or character of pollutants being discharged.

D. REOPENING OF PERMIT FOR MODIFICATIONS

In accordance with 38 M.R.S. §414-A(5) and based upon site inspections, additional site-specific or any other pertinent information or test results obtained during the term of this permit, the Department may, at any time and with notice to the permittee, modify this permit to establish limitations or require additional monitoring, inspections and/or reporting based on the new information.

E. SEVERABILITY

In the event that any provision(s), or part thereof, of this permit is declared to be unlawful by a reviewing court, the remainder of the permit will remain in full force and effect and will be construed and enforced in all respects as if such unlawful provision, or part thereof, had been omitted, unless otherwise ordered by the court.

**MAINE POLLUTANT DISCHARGE ELIMINATION SYSTEM PERMIT
AND
MAINE WASTE DISCHARGE LICENSE**

FACT SHEET

DATE: **August 11, 2023**

PERMIT NUMBER: **#ME0036722**

LICENSE NUMBER: **#W007582-5R-H-R**

NAME AND ADDRESS OF APPLICANT:

BROOKFIELD WHITE PINE HYDRO, LLC
on behalf of
ANDROSCOGGIN RESERVOIR COMPANY
150 MAIN ST
LEWISTON, ME 04240

NAME, ADDRESS, AND COUNTY WHERE DISCHARGE(S) OCCUR(S):

AZISCOHOS HYDRO PROJECT
14 DAM ROAD
LINCOLN PLANTATION, MAINE 04964
OXFORD COUNTY

COGNIZANT OFFICIAL CONTACT INFORMATION:

KYLE MURPHY
(207) 458-5861
EMAIL: kyle.murphy@brookfieldrenewable.com

1. APPLICATION SUMMARY

Application: ARCo has submitted a timely and complete application to the Department for renewal of combination Maine Pollutant Discharge Elimination System (MEPDES) permit #ME0036722/Waste Discharge License (WDL) #W007582-5R-G-R, which was issued by the Department on December 19, 2018 for a five-year term. The 12/19/2018 permit authorized the daily discharge of 270,000 gallons per day of non-contact cooling water and miscellaneous facility drainage from four outfalls at ARCo's Aziscohos Hydro Project to the Magalloway River, Class A, in Lincoln Plantation, Maine. A location map is included as Attachment A of this Fact Sheet.

2. PERMIT SUMMARY

- a. Terms and Conditions: This permitting action carries forward all the terms and conditions established in the previous permit.
- b. History: The most current regulatory actions include:

February 18, 1999 - The Department issued WDL renewal #W007582-5R-C-R for a five-year term.

January 12, 2001 – The Department received authorization from the USEPA to administer the NPDES permitting program in Maine, excluding areas of special interest to Maine Indian Tribes. From this point forward, the program has been referred to as the Maine Pollutant Discharge Elimination System (MEPDES) program, and MEPDES permit #ME0036722 has been utilized for this facility. On March 26, 2011, the USEPA authorized the Department to administer the MEPDES program in Indian territories of the Penobscot Nation and Passamaquoddy Tribe.

October 26, 2004 – The Department issued WDL renewal #W007582-5R-D-R for a five year term.

May 1, 2009 – The Department issued combination MEPDES permit ME 0036722/WDL renewal #W007582-5R-E-R for a five-year term.

March 17, 2014 – The Department issued combination MEPDES permit ME 0036722/WDL #W007582-5R-F-R for a five-year term.

October 31, 2018 - Brookfield White Pine Hydro, LLC submitted a timely and complete application to the Department on behalf of ARCo for renewal of combination MEPDES permit ME 0036722/WDL #W007582-5R-F-R. The application was accepted for processing on November 1, 2018, and was assigned WDL #W007582-5R-G-R.

December 19, 2018 – The Department issued combination MEPDES permit ME 0036722/WDL #W007582-5R-G-R for a five-year term.

March 21, 2023 -Brookfield White Pine Hydro, LLC submitted a timely and complete application to the Department on behalf of ARCo for renewal of combination MEPDES permit ME 0036722/WDL #W007582-5R-G-R. The application was accepted for processing on March 31, 2023, and was assigned WDL #W007582-5R-H-R.

2. PERMIT SUMMARY (cont'd)

- c. Source Description: The source of the discharge is a hydroelectric generating facility. The discharge consists of generator bearing and turbine non-contact cooling water, penstock drainage and roof drains from four outfalls. The discharge flow rate is variable, depending on cooling needs, up to a maximum flow of 270,000 gallons per day (maximum cooling system capacity, based on information from applicant).

Other miscellaneous discharges from the facility consist of shaft lubrication waters, foundation leakage waters, and/or leakage from wicket gates and other equipment. In the event of unplanned leaks, spills or equipment failure, these discharges may become contaminated with hydraulic or lubrication oil and grease.

All miscellaneous facility leakage and lubrication waters that may become contaminated with oil or grease are subject to Best Management Practices (BMPs) designed to prevent the release of contaminants to the waters of the State. Within 90 days of permit issuance, the permittee shall develop written BMPs and shall make the BMPs available to the Department for review and comment upon request.

BMPs must consist of, but not be limited to, the following, as appropriate: development and implementation of a spill prevention plan; use of oil absorbent pads or booms and/or physical berms to contain spills or leaks of hydraulic and lubrication oils; and the treatment of water collected in floor drains and sumps through an oil/grease trap or oil-water separator. Where bearing cooling water is used, BMPs must include the maintenance of a written log or record of bearing oil levels and maintenance activities.

Where floor drains and sumps are used, BMPs must include (1) written procedures for the cleaning and maintenance of any oil-grease trap, oil skimmer or oil-water separator and (2) maintenance of a written log or record of visual inspections of sumps for oil and grease and of actions taken to prevent the discharge of oil or grease from the facility. Miscellaneous facility drainage (i.e. roof drains, foundation leakage, penstock drainage, etc.) occurs through outfalls #002 and #003. A process flow diagram submitted by the permittee is included as Fact Sheet **Attachment B**.

3. CONDITIONS OF PERMITS

Conditions of licenses, 38 M.R.S. § 414-A, requires that the effluent limitations prescribed for discharges, including, but not limited to, effluent toxicity, require application of best practicable treatment (BPT), be consistent with the U.S. Clean Water Act, and ensure that the receiving waters attain the State water quality standards as described in Maine's Surface Water Classification System. In addition, 38 M.R.S. § 420 and 06-096 CMR 530 require the regulation of toxic substances not to exceed levels set forth in *Surface Water Quality Criteria for Toxic Pollutants*, 06-096 CMR 584 (last amended February 16, 2019), and that ensure safe levels for the discharge of toxic pollutants such that existing and designated uses of surface waters are maintained and protected.

4. RECEIVING WATER QUALITY STANDARDS

Classification of major river basins, 38 M.R.S., §467(1)(C) classifies the Androscoggin River “Upper Drainage; that portion within the State lying above the river’s most upstream crossing of the Maine-New Hampshire boundary,” which includes the reach of the Magalloway river subject to ARCo’s discharge, as Class A. *Standards for classification of fresh surface waters*, 38 M.R.S., § 465(2) describes the standards for Class A waters.

5. REGULATIONS RELATING TO TEMPERATURE

Regulations Relating to Temperature 06-096 CMR 582 (last amended February 18, 1989), states that no discharge shall cause the ambient temperature of any freshwater body to be raised more than 5 degrees Fahrenheit, nor shall any discharge cause the temperature of any waters to exceed the USEPA national ambient water quality criteria established to protect all species of fish that are indigenous to the receiving waters. When the ambient temperature of any body of water naturally exceeds the applicable USEPA criteria, no thermal discharge may be allowed which alone or in combination with other discharges would raise the ambient temperature of the receiving water more than 0.5 degrees Fahrenheit.

The Department has established that cold water fish species are indigenous to all Maine rivers and streams. USEPA has established maximum temperatures for the protection of growth and survival of cold water fish as follows: a weekly average temperature of 66 degrees Fahrenheit; and a daily maximum temperature of 73 degrees Fahrenheit.

6. EFFLUENT LIMITATIONS AND MONITORING REQUIREMENTS

The USEPA has not promulgated National Effluent Guidelines for non-contact cooling water. The Department has made a Best Professional Judgment (BPJ) determination that BPT for hydro project cooling water is no treatment, unless treatment to control thermal loading is determined to be required.

The Department has calculated that, under worst case conditions of maximum cooling water flow (270,000 GPD), maximum cooling water temperature (assumed 95 degrees Fahrenheit, based on staff analysis of industry data), and 7Q10 receiving water flow (400 cfs), and without any treatment to reduce thermal loading, the discharge will raise the ambient temperature of the receiving water by only 1/10th of a degree Fahrenheit. Therefore, the Department has determined that neither effluent limitations nor monitoring requirements are necessary to ensure that applicable water quality standards are met.

However, the discharge is subject to effluent limitations that require application of best practicable treatment as defined in 38 M.R.S. §414-A(1)(D). Within 90 days of permit issuance, the permittee shall develop BMPs and shall make the BMPs available in writing for the Department to review and comment upon request.

7. ANTI-DEGRADATION/DISCHARGE IMPACT ON RECEIVING WATER QUALITY

Federal regulation 40 CFR, §122(l) contains the criteria for what is often referred to as the anti-backsliding provisions of the Federal Water Pollution Control Act (Clean Water Act). In general, the regulation states that except for provisions specified in the regulation, effluent limitations, standards or conditions must be at least as stringent as the final effluent limitations, standards or conditions in the previous permit. Applicable exceptions include (1) material and substantial alterations or additions to the permitted facility occurred after permit issuance which justify the application of a less stringent effluent limitation and (2) information is available which was not available at the time of the permit issuance (other than revised regulations, guidance or test methods) and which would justify the application of less stringent effluent limitations at the time of permit issuance. All limitations in this permit are equally or more stringent than those in the previous permit.

8. PUBLIC COMMENTS

Public notice of this application was made in the Rangeley Highlander the week of April 1, 2023. The Department receives public comments on an application until the date a final agency action is taken on that application. Those persons receiving copies of draft permits shall have at least 30 days in which to submit comments on the draft or to request a public hearing, pursuant to *Application Processing Procedures for Waste Discharge Licenses*, 06-096 CMR 522 (effective January 12, 2001).

9. DEPARTMENT CONTACTS

Additional information concerning this permitting action may be obtained from and written comments should be sent to:

Rodney Robert
Division of Water Quality Management
Bureau of Water Quality
Department of Environmental Protection
17 State House Station
Augusta, Maine 04333-0017 Telephone: (207) 680-0576
e-mail: rodney.robert@maine.gov

10. RESPONSE TO COMMENTS

Reserved until the end of the formal thirty-day (30) comment period.

ATTACHMENT A

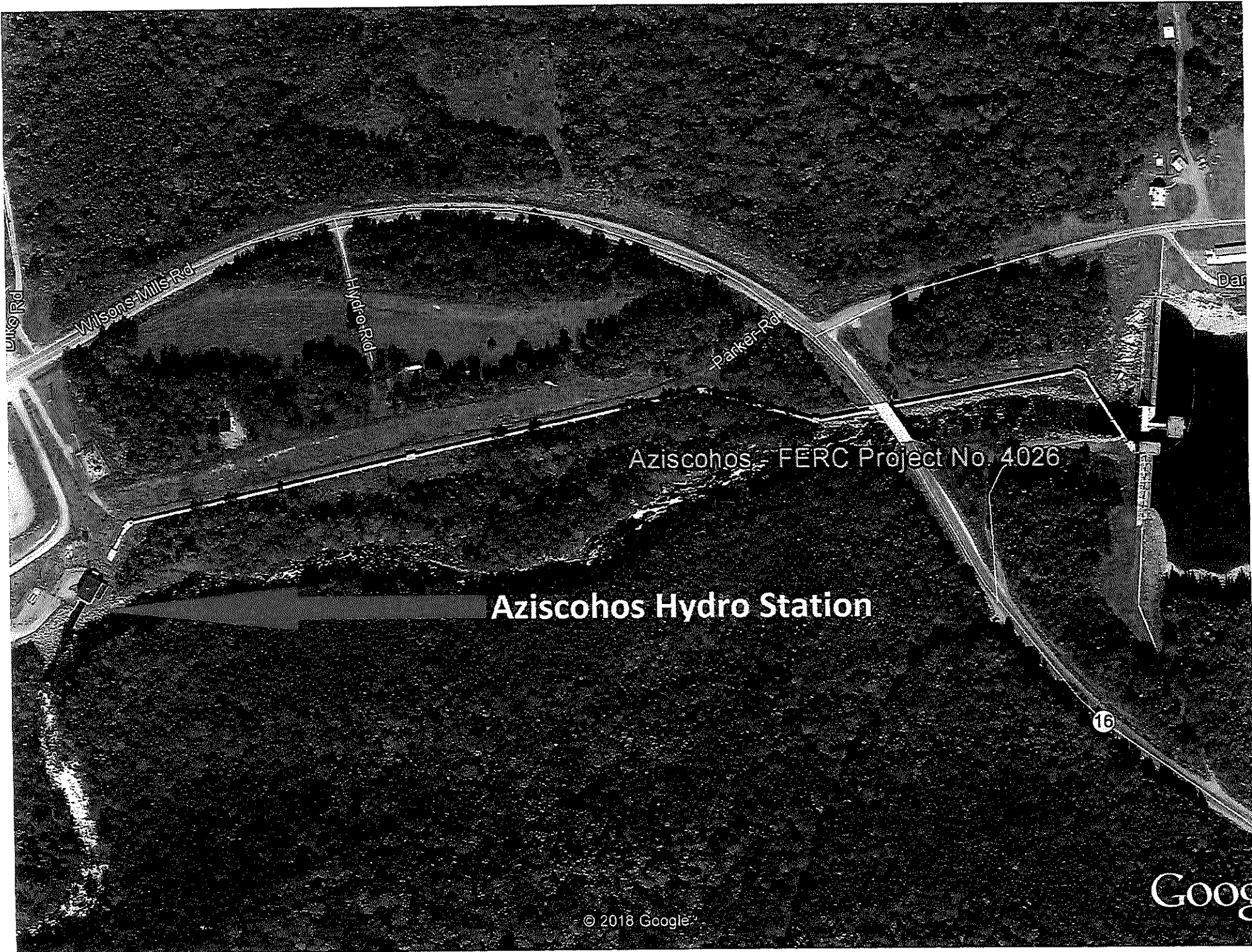

Aziscohos FERC Project No. 4026

Aziscohos Hydro Station

ATTACHMENT B

Aziscohos Hydro Project 2023 Water Flow Diagram

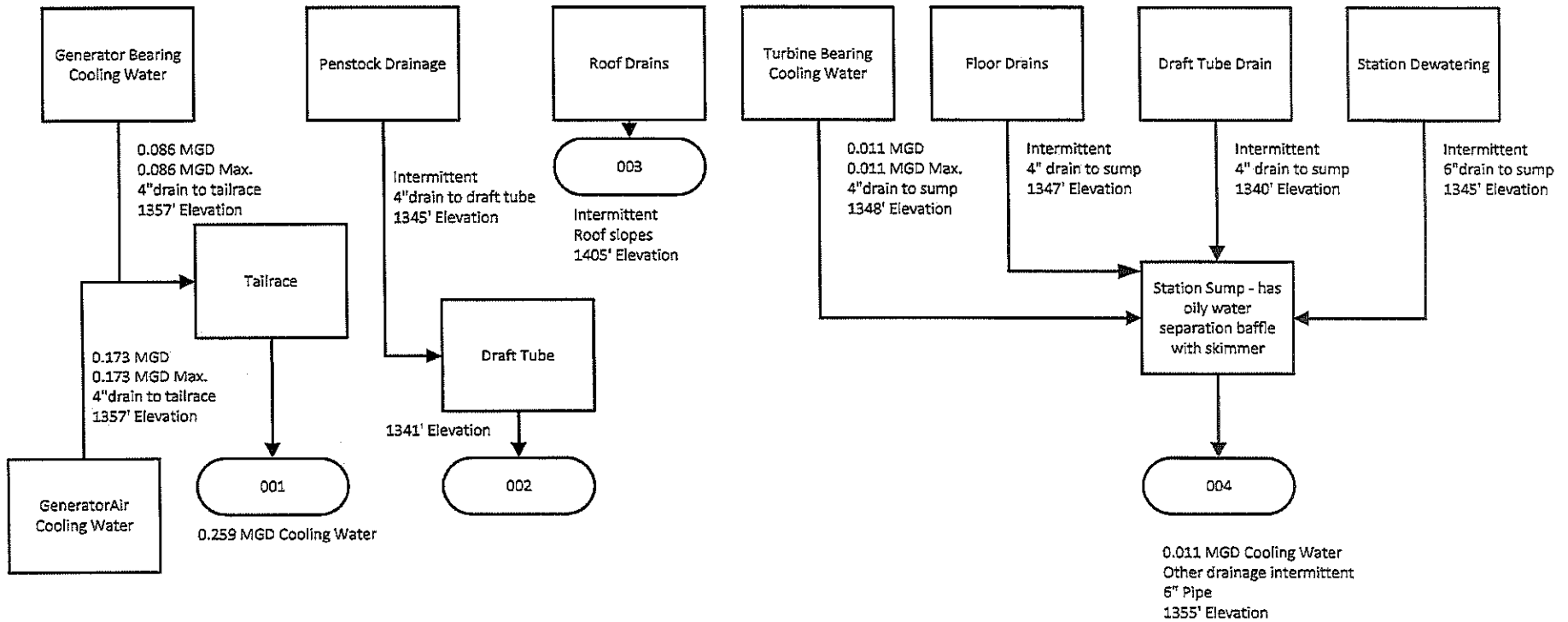

No sanitary facilities.

Maximum cooling is 0.27 MGD.

Small transformer in yard in crushed stone within concrete vault that drains to a manhole. The manhole has an oil trap valve. The outlet of the valve drains onto the surface banking which slopes to the station and the river.

MAINE POLLUTANT DISCHARGE ELIMINATION SYSTEM PERMIT

STANDARD CONDITIONS APPLICABLE TO ALL PERMITS

CONTENTS

SECTION	TOPIC	PAGE
A	GENERAL PROVISIONS	
1	General compliance	2
2	Other materials	2
3	Duty to Comply	2
4	Duty to provide information	2
5	Permit actions	2
6	Reopener clause	2
7	Oil and hazardous substances	2
8	Property rights	3
9	Confidentiality	3
10	Duty to reapply	3
11	Other laws	3
12	Inspection and entry	3
B	OPERATION AND MAINTENANCE OF FACILITIES	
1	General facility requirements	3
2	Proper operation and maintenance	4
3	Need to halt reduce not a defense	4
4	Duty to mitigate	4
5	Bypasses	4
6	Upsets	5
C	MONITORING AND RECORDS	
1	General requirements	6
2	Representative sampling	6
3	Monitoring and records	6
D	REPORTING REQUIREMENTS	
1	Reporting requirements	7
2	Signatory requirement	8
3	Availability of reports	8
4	Existing manufacturing, commercial, mining, and silvicultural dischargers	8
5	Publicly owned treatment works	9
E	OTHER PROVISIONS	
1	Emergency action - power failure	9
2	Spill prevention	10
3	Removed substances	10
4	Connection to municipal sewer	10
F	DEFINITIONS	10

MAINE POLLUTANT DISCHARGE ELIMINATION SYSTEM PERMIT

STANDARD CONDITIONS APPLICABLE TO ALL PERMITS

A. GENERAL PROVISIONS

1. General compliance. All discharges shall be consistent with the terms and conditions of this permit; any changes in production capacity or process modifications which result in changes in the quantity or the characteristics of the discharge must be authorized by an additional license or by modifications of this permit; it shall be a violation of the terms and conditions of this permit to discharge any pollutant not identified and authorized herein or to discharge in excess of the rates or quantities authorized herein or to violate any other conditions of this permit.

2. Other materials. Other materials ordinarily produced or used in the operation of this facility, which have been specifically identified in the application, may be discharged at the maximum frequency and maximum level identified in the application, provided:

- (a) They are not
 - (i) Designated as toxic or hazardous under the provisions of Sections 307 and 311, respectively, of the Federal Water Pollution Control Act; Title 38, Section 420, Maine Revised Statutes; or other applicable State Law; or
 - (ii) Known to be hazardous or toxic by the licensee.
- (b) The discharge of such materials will not violate applicable water quality standards.

3. Duty to comply. The permittee must comply with all conditions of this permit. Any permit noncompliance constitutes a violation of State law and the Clean Water Act and is grounds for enforcement action; for permit termination, revocation and reissuance, or modification; or denial of a permit renewal application.

- (a) The permittee shall comply with effluent standards or prohibitions established under section 307(a) of the Clean Water Act, and 38 MRSA, §420 or Chapter 530.5 for toxic pollutants within the time provided in the regulations that establish these standards or prohibitions, even if the permit has not yet been modified to incorporate the requirement.
- (b) Any person who violates any provision of the laws administered by the Department, including without limitation, a violation of the terms of any order, rule license, permit, approval or decision of the Board or Commissioner is subject to the penalties set forth in 38 MRSA, §349.

4. Duty to provide information. The permittee shall furnish to the Department, within a reasonable time, any information which the Department may request to determine whether cause exists for modifying, revoking and reissuing, or terminating this permit or to determine compliance with this permit. The permittee shall also furnish to the Department upon request, copies of records required to be kept by this permit.

5. Permit actions. This permit may be modified, revoked and reissued, or terminated for cause. The filing of a request by the permittee for a permit modification, revocation and reissuance, or termination, or a notification of planned changes or anticipated noncompliance does not stay any permit condition.

6. Reopener clause. The Department reserves the right to make appropriate revisions to this permit in order to establish any appropriate effluent limitations, schedule of compliance or other provisions which may be authorized under 38 MRSA, §414-A(5).

MAINE POLLUTANT DISCHARGE ELIMINATION SYSTEM PERMIT

STANDARD CONDITIONS APPLICABLE TO ALL PERMITS

7. Oil and hazardous substances. Nothing in this permit shall be construed to preclude the institution of any legal action or relieve the permittee from any responsibilities, liabilities or penalties to which the permittee is or may be subject under section 311 of the Federal Clean Water Act; section 106 of the Federal Comprehensive Environmental Response, Compensation and Liability Act of 1980; or 38 MRSA §§ 1301, et. seq.

8. Property rights. This permit does not convey any property rights of any sort, or any exclusive privilege.

9. Confidentiality of records. 38 MRSA §414(6) reads as follows. "Any records, reports or information obtained under this subchapter is available to the public, except that upon a showing satisfactory to the department by any person that any records, reports or information, or particular part or any record, report or information, other than the names and addresses of applicants, license applications, licenses, and effluent data, to which the department has access under this subchapter would, if made public, divulge methods or processes that are entitled to protection as trade secrets, these records, reports or information must be confidential and not available for public inspection or examination. Any records, reports or information may be disclosed to employees or authorized representatives of the State or the United States concerned with carrying out this subchapter or any applicable federal law, and to any party to a hearing held under this section on terms the commissioner may prescribe in order to protect these confidential records, reports and information, as long as this disclosure is material and relevant to any issue under consideration by the department."

10. Duty to reapply. If the permittee wishes to continue an activity regulated by this permit after the expiration date of this permit, the permittee must apply for and obtain a new permit.

11. Other laws. The issuance of this permit does not authorize any injury to persons or property or invasion of other property rights, nor does it relieve the permittee of its obligation to comply with other applicable Federal, State or local laws and regulations.

12. Inspection and entry. The permittee shall allow the Department, or an authorized representative (including an authorized contractor acting as a representative of the EPA Administrator), upon presentation of credentials and other documents as may be required by law, to:

- (a) Enter upon the permittee's premises where a regulated facility or activity is located or conducted, or where records must be kept under the conditions of this permit;
- (b) Have access to and copy, at reasonable times, any records that must be kept under the conditions of this permit;
- (c) Inspect at reasonable times any facilities, equipment (including monitoring and control equipment), practices, or operations regulated or required under this permit; and
- (d) Sample or monitor at reasonable times, for the purposes of assuring permit compliance or as otherwise authorized by the Clean Water Act, any substances or parameters at any location.

B. OPERATION AND MAINTENANCE OF FACILITIES

1. General facility requirements.

- (a) The permittee shall collect all waste flows designated by the Department as requiring treatment and discharge them into an approved waste treatment facility in such a manner as to

MAINE POLLUTANT DISCHARGE ELIMINATION SYSTEM PERMIT

STANDARD CONDITIONS APPLICABLE TO ALL PERMITS

- maximize removal of pollutants unless authorization to the contrary is obtained from the Department.
- (b) The permittee shall at all times maintain in good working order and operate at maximum efficiency all waste water collection, treatment and/or control facilities.
 - (c) All necessary waste treatment facilities will be installed and operational prior to the discharge of any wastewaters.
 - (d) Final plans and specifications must be submitted to the Department for review prior to the construction or modification of any treatment facilities.
 - (e) The permittee shall install flow measuring facilities of a design approved by the Department.
 - (f) The permittee must provide an outfall of a design approved by the Department which is placed in the receiving waters in such a manner that the maximum mixing and dispersion of the wastewaters will be achieved as rapidly as possible.

2. Proper operation and maintenance. The permittee shall at all times properly operate and maintain all facilities and systems of treatment and control (and related appurtenances) which are installed or used by the permittee to achieve compliance with the conditions of this permit. Proper operation and maintenance also includes adequate laboratory controls and appropriate quality assurance procedures. This provision requires the operation of back-up or auxiliary facilities or similar systems which are installed by a permittee only when the operation is necessary to achieve compliance with the conditions of the permit.

3. Need to halt or reduce activity not a defense. It shall not be a defense for a permittee in an enforcement action that it would have been necessary to halt or reduce the permitted activity in order to maintain compliance with the conditions of this permit.

4. Duty to mitigate. The permittee shall take all reasonable steps to minimize or prevent any discharge or sludge use or disposal in violation of this permit which has a reasonable likelihood of adversely affecting human health or the environment.

5. Bypasses.

- (a) Definitions.
 - (i) Bypass means the intentional diversion of waste streams from any portion of a treatment facility.
 - (ii) Severe property damage means substantial physical damage to property, damage to the treatment facilities which causes them to become inoperable, or substantial and permanent loss of natural resources which can reasonably be expected to occur in the absence of a bypass. Severe property damage does not mean economic loss caused by delays in production.
- (b) Bypass not exceeding limitations. The permittee may allow any bypass to occur which does not cause effluent limitations to be exceeded, but only if it also is for essential maintenance to assure efficient operation. These bypasses are not subject to the provisions of paragraphs (c) and (d) of this section.
- (c) Notice.
 - (i) Anticipated bypass. If the permittee knows in advance of the need for a bypass, it shall submit prior notice, if possible at least ten days before the date of the bypass.

MAINE POLLUTANT DISCHARGE ELIMINATION SYSTEM PERMIT

STANDARD CONDITIONS APPLICABLE TO ALL PERMITS

- (ii) Unanticipated bypass. The permittee shall submit notice of an unanticipated bypass as required in paragraph D(1)(f), below. (24-hour notice).
- (d) Prohibition of bypass.
 - (i) Bypass is prohibited, and the Department may take enforcement action against a permittee for bypass, unless:
 - (A) Bypass was unavoidable to prevent loss of life, personal injury, or severe property damage;
 - (B) There were no feasible alternatives to the bypass, such as the use of auxiliary treatment facilities, retention of untreated wastes, or maintenance during normal periods of equipment downtime. This condition is not satisfied if adequate back-up equipment should have been installed in the exercise of reasonable engineering judgment to prevent a bypass which occurred during normal periods of equipment downtime or preventive maintenance; and
 - (C) The permittee submitted notices as required under paragraph (c) of this section.
 - (ii) The Department may approve an anticipated bypass, after considering its adverse effects, if the Department determines that it will meet the three conditions listed above in paragraph (d)(i) of this section.

6. Upsets.

- (a) Definition. Upset means an exceptional incident in which there is unintentional and temporary noncompliance with technology based permit effluent limitations because of factors beyond the reasonable control of the permittee. An upset does not include noncompliance to the extent caused by operational error, improperly designed treatment facilities, inadequate treatment facilities, lack of preventive maintenance, or careless or improper operation.
- (b) Effect of an upset. An upset constitutes an affirmative defense to an action brought for noncompliance with such technology based permit effluent limitations if the requirements of paragraph (c) of this section are met. No determination made during administrative review of claims that noncompliance was caused by upset, and before an action for noncompliance, is final administrative action subject to judicial review.
- (c) Conditions necessary for a demonstration of upset. A permittee who wishes to establish the affirmative defense of upset shall demonstrate, through properly signed, contemporaneous operating logs, or other relevant evidence that:
 - (i) An upset occurred and that the permittee can identify the cause(s) of the upset;
 - (ii) The permitted facility was at the time being properly operated; and
 - (iii) The permittee submitted notice of the upset as required in paragraph D(1)(f) , below. (24 hour notice).
 - (iv) The permittee complied with any remedial measures required under paragraph B(4).
- (d) Burden of proof. In any enforcement proceeding the permittee seeking to establish the occurrence of an upset has the burden of proof.

MAINE POLLUTANT DISCHARGE ELIMINATION SYSTEM PERMIT

STANDARD CONDITIONS APPLICABLE TO ALL PERMITS

C. MONITORING AND RECORDS

1. General Requirements. This permit shall be subject to such monitoring requirements as may be reasonably required by the Department including the installation, use and maintenance of monitoring equipment or methods (including, where appropriate, biological monitoring methods). The permittee shall provide the Department with periodic reports on the proper Department reporting form of monitoring results obtained pursuant to the monitoring requirements contained herein.

2. Representative sampling. Samples and measurements taken as required herein shall be representative of the volume and nature of the monitored discharge. If effluent limitations are based wholly or partially on quantities of a product processed, the permittee shall ensure samples are representative of times when production is taking place. Where discharge monitoring is required when production is less than 50%, the resulting data shall be reported as a daily measurement but not included in computation of averages, unless specifically authorized by the Department.

3. Monitoring and records.

- (a) Samples and measurements taken for the purpose of monitoring shall be representative of the monitored activity.
- (b) Except for records of monitoring information required by this permit related to the permittee's sewage sludge use and disposal activities, which shall be retained for a period of at least five years, the permittee shall retain records of all monitoring information, including all calibration and maintenance records and all original strip chart recordings for continuous monitoring instrumentation, copies of all reports required by this permit, and records of all data used to complete the application for this permit, for a period of at least 3 years from the date of the sample, measurement, report or application. This period may be extended by request of the Department at any time.
- (c) Records of monitoring information shall include:
 - (i) The date, exact place, and time of sampling or measurements;
 - (ii) The individual(s) who performed the sampling or measurements;
 - (iii) The date(s) analyses were performed;
 - (iv) The individual(s) who performed the analyses;
 - (v) The analytical techniques or methods used; and
 - (vi) The results of such analyses.
- (d) Monitoring results must be conducted according to test procedures approved under 40 CFR part 136, unless other test procedures have been specified in the permit.
- (e) State law provides that any person who tampers with or renders inaccurate any monitoring devices or method required by any provision of law, or any order, rule license, permit approval or decision is subject to the penalties set forth in 38 MRSA, §349.

MAINE POLLUTANT DISCHARGE ELIMINATION SYSTEM PERMIT

STANDARD CONDITIONS APPLICABLE TO ALL PERMITS

D. REPORTING REQUIREMENTS

1. Reporting requirements.

- (a) Planned changes. The permittee shall give notice to the Department as soon as possible of any planned physical alterations or additions to the permitted facility. Notice is required only when:
 - (i) The alteration or addition to a permitted facility may meet one of the criteria for determining whether a facility is a new source in 40 CFR 122.29(b); or
 - (ii) The alteration or addition could significantly change the nature or increase the quantity of pollutants discharged. This notification applies to pollutants which are subject neither to effluent limitations in the permit, nor to notification requirements under Section D(4).
 - (iii) The alteration or addition results in a significant change in the permittee's sludge use or disposal practices, and such alteration, addition, or change may justify the application of permit conditions that are different from or absent in the existing permit, including notification of additional use or disposal sites not reported during the permit application process or not reported pursuant to an approved land application plan;
- (b) Anticipated noncompliance. The permittee shall give advance notice to the Department of any planned changes in the permitted facility or activity which may result in noncompliance with permit requirements.
- (c) Transfers. This permit is not transferable to any person except upon application to and approval of the Department pursuant to 38 MRSA, § 344 and Chapters 2 and 522.
- (d) Monitoring reports. Monitoring results shall be reported at the intervals specified elsewhere in this permit.
 - (i) Monitoring results must be reported on a Discharge Monitoring Report (DMR) or forms provided or specified by the Department for reporting results of monitoring of sludge use or disposal practices.
 - (ii) If the permittee monitors any pollutant more frequently than required by the permit using test procedures approved under 40 CFR part 136 or as specified in the permit, the results of this monitoring shall be included in the calculation and reporting of the data submitted in the DMR or sludge reporting form specified by the Department.
 - (iii) Calculations for all limitations which require averaging of measurements shall utilize an arithmetic mean unless otherwise specified by the Department in the permit.
- (e) Compliance schedules. Reports of compliance or noncompliance with, or any progress reports on, interim and final requirements contained in any compliance schedule of this permit shall be submitted no later than 14 days following each schedule date.
- (f) Twenty-four hour reporting.
 - (i) The permittee shall report any noncompliance which may endanger health or the environment. Any information shall be provided orally within 24 hours from the time the permittee becomes aware of the circumstances. A written submission shall also be provided within 5 days of the time the permittee becomes aware of the circumstances. The written submission shall contain a description of the noncompliance and its cause; the period of noncompliance, including exact dates and times, and if the noncompliance

MAINE POLLUTANT DISCHARGE ELIMINATION SYSTEM PERMIT

STANDARD CONDITIONS APPLICABLE TO ALL PERMITS

has not been corrected, the anticipated time it is expected to continue; and steps taken or planned to reduce, eliminate, and prevent reoccurrence of the noncompliance.

(ii) The following shall be included as information which must be reported within 24 hours under this paragraph.

(A) Any unanticipated bypass which exceeds any effluent limitation in the permit.

(B) Any upset which exceeds any effluent limitation in the permit.

(C) Violation of a maximum daily discharge limitation for any of the pollutants listed by the Department in the permit to be reported within 24 hours.

(iii) The Department may waive the written report on a case-by-case basis for reports under paragraph (f)(ii) of this section if the oral report has been received within 24 hours.

(g) Other noncompliance. The permittee shall report all instances of noncompliance not reported under paragraphs (d), (e), and (f) of this section, at the time monitoring reports are submitted. The reports shall contain the information listed in paragraph (f) of this section.

(h) Other information. Where the permittee becomes aware that it failed to submit any relevant facts in a permit application, or submitted incorrect information in a permit application or in any report to the Department, it shall promptly submit such facts or information.

2. Signatory requirement. All applications, reports, or information submitted to the Department shall be signed and certified as required by Chapter 521, Section 5 of the Department's rules. State law provides that any person who knowingly makes any false statement, representation or certification in any application, record, report, plan or other document filed or required to be maintained by any order, rule, permit, approval or decision of the Board or Commissioner is subject to the penalties set forth in 38 MRSA, §349.

3. Availability of reports. Except for data determined to be confidential under A(9), above, all reports prepared in accordance with the terms of this permit shall be available for public inspection at the offices of the Department. As required by State law, effluent data shall not be considered confidential. Knowingly making any false statement on any such report may result in the imposition of criminal sanctions as provided by law.

4. Existing manufacturing, commercial, mining, and silvicultural dischargers. In addition to the reporting requirements under this Section, all existing manufacturing, commercial, mining, and silvicultural dischargers must notify the Department as soon as they know or have reason to believe:

(a) That any activity has occurred or will occur which would result in the discharge, on a routine or frequent basis, of any toxic pollutant which is not limited in the permit, if that discharge will exceed the highest of the following "notification levels":

(i) One hundred micrograms per liter (100 ug/l);

(ii) Two hundred micrograms per liter (200 ug/l) for acrolein and acrylonitrile; five hundred micrograms per liter (500 ug/l) for 2,4-dinitrophenol and for 2-methyl-4,6-dinitrophenol; and one milligram per liter (1 mg/l) for antimony;

(iii) Five (5) times the maximum concentration value reported for that pollutant in the permit application in accordance with Chapter 521 Section 4(g)(7); or

(iv) The level established by the Department in accordance with Chapter 523 Section 5(f).

MAINE POLLUTANT DISCHARGE ELIMINATION SYSTEM PERMIT

STANDARD CONDITIONS APPLICABLE TO ALL PERMITS

- (b) That any activity has occurred or will occur which would result in any discharge, on a non-routine or infrequent basis, of a toxic pollutant which is not limited in the permit, if that discharge will exceed the highest of the following "notification levels":
 - (i) Five hundred micrograms per liter (500 ug/l);
 - (ii) One milligram per liter (1 mg/l) for antimony;
 - (iii) Ten (10) times the maximum concentration value reported for that pollutant in the permit application in accordance with Chapter 521 Section 4(g)(7); or
 - (iv) The level established by the Department in accordance with Chapter 523 Section 5(f).

5. Publicly owned treatment works.

- (a) All POTWs must provide adequate notice to the Department of the following:
 - (i) Any new introduction of pollutants into the POTW from an indirect discharger which would be subject to section 301 or 306 of CWA or Chapter 528 if it were directly discharging those pollutants.
 - (ii) Any substantial change in the volume or character of pollutants being introduced into that POTW by a source introducing pollutants into the POTW at the time of issuance of the permit.
 - (iii) For purposes of this paragraph, adequate notice shall include information on (A) the quality and quantity of effluent introduced into the POTW, and (B) any anticipated impact of the change on the quantity or quality of effluent to be discharged from the POTW.
- (b) When the effluent discharged by a POTW for a period of three consecutive months exceeds 80 percent of the permitted flow, the permittee shall submit to the Department a projection of loadings up to the time when the design capacity of the treatment facility will be reached, and a program for maintaining satisfactory treatment levels consistent with approved water quality management plans.

E. OTHER REQUIREMENTS

1. Emergency action - power failure. Within thirty days after the effective date of this permit, the permittee shall notify the Department of facilities and plans to be used in the event the primary source of power to its wastewater pumping and treatment facilities fails as follows.

- (a) For municipal sources. During power failure, all wastewaters which are normally treated shall receive a minimum of primary treatment and disinfection. Unless otherwise approved, alternate power supplies shall be provided for pumping stations and treatment facilities. Alternate power supplies shall be on-site generating units or an outside power source which is separate and independent from sources used for normal operation of the wastewater facilities.
- (b) For industrial and commercial sources. The permittee shall either maintain an alternative power source sufficient to operate the wastewater pumping and treatment facilities or halt, reduce or otherwise control production and or all discharges upon reduction or loss of power to the wastewater pumping or treatment facilities.

MAINE POLLUTANT DISCHARGE ELIMINATION SYSTEM PERMIT

STANDARD CONDITIONS APPLICABLE TO ALL PERMITS

2. Spill prevention. (applicable only to industrial sources) Within six months of the effective date of this permit, the permittee shall submit to the Department for review and approval, with or without conditions, a spill prevention plan. The plan shall delineate methods and measures to be taken to prevent and or contain any spills of pulp, chemicals, oils or other contaminants and shall specify means of disposal and or treatment to be used.

3. Removed substances. Solids, sludges trash rack cleanings, filter backwash, or other pollutants removed from or resulting from the treatment or control of waste waters shall be disposed of in a manner approved by the Department.

4. Connection to municipal sewer. (applicable only to industrial and commercial sources) All wastewaters designated by the Department as treatable in a municipal treatment system will be cosigned to that system when it is available. This permit will expire 90 days after the municipal treatment facility becomes available, unless this time is extended by the Department in writing.

F. DEFINITIONS. For the purposes of this permit, the following definitions shall apply. Other definitions applicable to this permit may be found in Chapters 520 through 529 of the Department's rules

Average means the arithmetic mean of values taken at the frequency required for each parameter over the specified period. For bacteria, the average shall be the geometric mean.

Average monthly discharge limitation means the highest allowable average of daily discharges over a calendar month, calculated as the sum of all daily discharges measured during a calendar month divided by the number of daily discharges measured during that month. Except, however, bacteriological tests may be calculated as a geometric mean.

Average weekly discharge limitation means the highest allowable average of daily discharges over a calendar week, calculated as the sum of all daily discharges measured during a calendar week divided by the number of daily discharges measured during that week.

Best management practices ("BMPs") means schedules of activities, prohibitions of practices, maintenance procedures, and other management practices to prevent or reduce the pollution of waters of the State. BMPs also include treatment requirements, operating procedures, and practices to control plant site runoff, spillage or leaks, sludge or waste disposal, or drainage from raw material storage.

Composite sample means a sample consisting of a minimum of eight grab samples collected at equal intervals during a 24 hour period (or a lesser period as specified in the section on monitoring and reporting) and combined proportional to the flow over that same time period.

Continuous discharge means a discharge which occurs without interruption throughout the operating hours of the facility, except for infrequent shutdowns for maintenance, process changes, or other similar activities.

Daily discharge means the discharge of a pollutant measured during a calendar day or any 24-hour period that reasonably represents the calendar day for purposes of sampling. For pollutants with limitations expressed in units of mass, the daily discharge is calculated as the total mass of the pollutant discharged over the day. For pollutants with limitations expressed in other units of measurement, the daily discharge is calculated as the average measurement of the pollutant over the day.

MAINE POLLUTANT DISCHARGE ELIMINATION SYSTEM PERMIT

STANDARD CONDITIONS APPLICABLE TO ALL PERMITS

Discharge Monitoring Report ("DMR") means the EPA uniform national form, including any subsequent additions, revisions, or modifications for the reporting of self-monitoring results by permittees. DMRs must be used by approved States as well as by EPA. EPA will supply DMRs to any approved State upon request. The EPA national forms may be modified to substitute the State Agency name, address, logo, and other similar information, as appropriate, in place of EPA's.

Flow weighted composite sample means a composite sample consisting of a mixture of aliquots collected at a constant time interval, where the volume of each aliquot is proportional to the flow rate of the discharge.

Grab sample means an individual sample collected in a period of less than 15 minutes.

Interference means a Discharge which, alone or in conjunction with a discharge or discharges from other sources, both:

- (1) Inhibits or disrupts the POTW, its treatment processes or operations, or its sludge processes, use or disposal; and
- (2) Therefore is a cause of a violation of any requirement of the POTW's NPDES permit (including an increase in the magnitude or duration of a violation) or of the prevention of sewage sludge use or disposal in compliance with the following statutory provisions and regulations or permits issued thereunder (or more stringent State or local regulations): Section 405 of the Clean Water Act, the Solid Waste Disposal Act (SWDA) (including title II, more commonly referred to as the Resource Conservation and Recovery Act (RCRA), and including State regulations contained in any State sludge management plan prepared pursuant to subtitle D of the SWDA), the Clean Air Act, the Toxic Substances Control Act, and the Marine Protection, Research and Sanctuaries Act.

Maximum daily discharge limitation means the highest allowable daily discharge.

New source means any building, structure, facility, or installation from which there is or may be a discharge of pollutants, the construction of which commenced:

- (a) After promulgation of standards of performance under section 306 of CWA which are applicable to such source, or
- (b) After proposal of standards of performance in accordance with section 306 of CWA which are applicable to such source, but only if the standards are promulgated in accordance with section 306 within 120 days of their proposal.

Pass through means a discharge which exits the POTW into waters of the State in quantities or concentrations which, alone or in conjunction with a discharge or discharges from other sources, is a cause of a violation of any requirement of the POTW's NPDES permit (including an increase in the magnitude or duration of a violation).

Permit means an authorization, license, or equivalent control document issued by EPA or an approved State to implement the requirements of 40 CFR parts 122, 123 and 124. Permit includes an NPDES general permit (Chapter 529). Permit does not include any permit which has not yet been the subject of final agency action, such as a draft permit or a proposed permit.

Person means an individual, firm, corporation, municipality, quasi-municipal corporation, state agency, federal agency or other legal entity.

MAINE POLLUTANT DISCHARGE ELIMINATION SYSTEM PERMIT

STANDARD CONDITIONS APPLICABLE TO ALL PERMITS

Point source means any discernible, confined and discrete conveyance, including, but not limited to, any pipe, ditch, channel, tunnel, conduit, well, discrete fissure, container, rolling stock, concentrated animal feeding operation or vessel or other floating craft, from which pollutants are or may be discharged.

Pollutant means dredged spoil, solid waste, junk, incinerator residue, sewage, refuse, effluent, garbage, sewage sludge, munitions, chemicals, biological or radiological materials, oil, petroleum products or byproducts, heat, wrecked or discarded equipment, rock, sand, dirt and industrial, municipal, domestic, commercial or agricultural wastes of any kind.

Process wastewater means any water which, during manufacturing or processing, comes into direct contact with or results from the production or use of any raw material, intermediate product, finished product, byproduct, or waste product.

Publicly owned treatment works ("POTW") means any facility for the treatment of pollutants owned by the State or any political subdivision thereof, any municipality, district, quasi-municipal corporation or other public entity.

Septage means, for the purposes of this permit, any waste, refuse, effluent sludge or other material removed from a septic tank, cesspool, vault privy or similar source which concentrates wastes or to which chemicals have been added. Septage does not include wastes from a holding tank.

Time weighted composite means a composite sample consisting of a mixture of equal volume aliquots collected over a constant time interval.

Toxic pollutant includes any pollutant listed as toxic under section 307(a)(1) or, in the case of sludge use or disposal practices, any pollutant identified in regulations implementing section 405(d) of the CWA. Toxic pollutant also includes those substances or combination of substances, including disease causing agents, which after discharge or upon exposure, ingestion, inhalation or assimilation into any organism, including humans either directly through the environment or indirectly through ingestion through food chains, will, on the basis of information available to the board either alone or in combination with other substances already in the receiving waters or the discharge, cause death, disease, abnormalities, cancer, genetic mutations, physiological malfunctions, including malfunctions in reproduction, or physical deformations in such organism or their offspring.

Wetlands means those areas that are inundated or saturated by surface or ground water at a frequency and duration sufficient to support, and that under normal circumstances do support, a prevalence of vegetation typically adapted for life in saturated soil conditions. Wetlands generally include swamps, marshes, bogs, and similar areas.

Whole effluent toxicity means the aggregate toxic effect of an effluent measured directly by a toxicity test.



DEP INFORMATION SHEET

Appealing a Department Licensing Decision

Dated: August 2021

Contact: (207) 314-1458

SUMMARY

This document provides information regarding a person's rights and obligations in filing an administrative or judicial appeal of a licensing decision made by the Department of Environmental Protection's (DEP) Commissioner.

Except as provided below, there are two methods available to an aggrieved person seeking to appeal a licensing decision made by the DEP Commissioner: (1) an administrative process before the Board of Environmental Protection (Board); or (2) a judicial process before Maine's Superior Court. An aggrieved person seeking review of a licensing decision over which the Board had original jurisdiction may seek judicial review in Maine's Superior Court.

A judicial appeal of final action by the Commissioner or the Board regarding an application for an expedited wind energy development ([35-A M.R.S. § 3451\(4\)](#)) or a general permit for an offshore wind energy demonstration project ([38 M.R.S. § 480-HH\(1\)](#)) or a general permit for a tidal energy demonstration project ([38 M.R.S. § 636-A](#)) must be taken to the Supreme Judicial Court sitting as the Law Court.

I. ADMINISTRATIVE APPEALS TO THE BOARD

LEGAL REFERENCES

A person filing an appeal with the Board should review Organization and Powers, [38 M.R.S. §§ 341-D\(4\)](#) and [346](#); the Maine Administrative Procedure Act, 5 M.R.S. § [11001](#); and the DEP's [Rule Concerning the Processing of Applications and Other Administrative Matters \(Chapter 2\)](#), 06-096 C.M.R. ch. 2.

DEADLINE TO SUBMIT AN APPEAL TO THE BOARD

Not more than 30 days following the filing of a license decision by the Commissioner with the Board, an aggrieved person may appeal to the Board for review of the Commissioner's decision. The filing of an appeal with the Board, in care of the Board Clerk, is complete when the Board receives the submission by the close of business on the due date (5:00 p.m. on the 30th calendar day from which the Commissioner's decision was filed with the Board, as determined by the received time stamp on the document or electronic mail). Appeals filed after 5:00 p.m. on the 30th calendar day from which the Commissioner's decision was filed with the Board will be dismissed as untimely, absent a showing of good cause.

HOW TO SUBMIT AN APPEAL TO THE BOARD

An appeal to the Board may be submitted via postal mail or electronic mail and must contain all signatures and required appeal contents. An electronic filing must contain the scanned original signature of the appellant(s). The appeal documents must be sent to the following address.

Chair, Board of Environmental Protection
c/o Board Clerk
17 State House Station
Augusta, ME 04333-0017
ruth.a.burke@maine.gov

The DEP may also request the submittal of the original signed paper appeal documents when the appeal is filed electronically. The risk of material not being received in a timely manner is on the sender, regardless of the method used.

At the time an appeal is filed with the Board, the appellant must send a copy of the appeal to: (1) the Commissioner of the DEP (Maine Department of Environmental Protection, 17 State House Station, Augusta, Maine 04333-0017); (2) the licensee; and if a hearing was held on the application, (3) any intervenors in that hearing proceeding. **Please contact the DEP at 207-287-7688 with questions or for contact information regarding a specific licensing decision.**

REQUIRED APPEAL CONTENTS

A complete appeal must contain the following information at the time the appeal is submitted.

1. *Aggrieved status.* The appeal must explain how the appellant has standing to bring the appeal. This requires an explanation of how the appellant may suffer a particularized injury as a result of the Commissioner's decision.
2. *The findings, conclusions, or conditions objected to or believed to be in error.* The appeal must identify the specific findings of fact, conclusions of law, license conditions, or other aspects of the written license decision or of the license review process that the appellant objects to or believes to be in error.
3. *The basis of the objections or challenge.* For the objections identified in Item #2, the appeal must state why the appellant believes that the license decision is incorrect and should be modified or reversed. If possible, the appeal should cite specific evidence in the record or specific licensing criteria that the appellant believes were not properly considered or fully addressed.
4. *The remedy sought.* This can range from reversal of the Commissioner's decision on the license to changes in specific license conditions.
5. *All the matters to be contested.* The Board will limit its consideration to those matters specifically raised in the written notice of appeal.
6. *Request for hearing.* If the appellant wishes the Board to hold a public hearing on the appeal, a request for hearing must be filed as part of the notice of appeal, and it must include an offer of proof regarding the testimony and other evidence that would be presented at the hearing. The offer of proof must consist of a statement of the substance of the evidence, its relevance to the issues on appeal, and whether any witnesses would testify. The Board will hear the arguments in favor of and in opposition to a hearing on the appeal and the presentations on the merits of an appeal at a regularly scheduled meeting. If the Board decides to hold a public hearing on an appeal, that hearing will then be scheduled for a later date.
7. *New or additional evidence to be offered.* If an appellant wants to provide evidence not previously provided to DEP staff during the DEP's review of the application, the request and the proposed supplemental evidence must be submitted with the appeal. The Board may allow new or additional evidence to be considered in an appeal only under limited circumstances. The proposed supplemental evidence must be relevant and material, and (a) the person seeking to add information to the record must show due diligence in bringing the evidence to the DEP's attention at the earliest possible time in the licensing process; or (b) the evidence itself must be newly discovered and therefore unable to have been presented earlier in the process. Requirements for supplemental evidence are set forth in [Chapter 2 § 24](#).

OTHER CONSIDERATIONS IN APPEALING A DECISION TO THE BOARD

1. *Be familiar with all relevant material in the DEP record.* A license application file is public information, subject to any applicable statutory exceptions, and is made accessible by the DEP. Upon request, the DEP will make application materials available to review and photocopy during normal working hours. There may be a charge for copies or copying services.

2. *Be familiar with the regulations and laws under which the application was processed, and the procedural rules governing the appeal.* DEP staff will provide this information upon request and answer general questions regarding the appeal process.
3. *The filing of an appeal does not operate as a stay to any decision.* If a license has been granted and it has been appealed, the license normally remains in effect pending the processing of the appeal. Unless a stay of the decision is requested and granted, a licensee may proceed with a project pending the outcome of an appeal, but the licensee runs the risk of the decision being reversed or modified as a result of the appeal.

WHAT TO EXPECT ONCE YOU FILE A TIMELY APPEAL WITH THE BOARD

The Board will acknowledge receipt of an appeal, and it will provide the name of the DEP project manager assigned to the specific appeal. The notice of appeal, any materials admitted by the Board as supplementary evidence, any materials admitted in response to the appeal, relevant excerpts from the DEP's administrative record for the application, and the DEP staff's recommendation, in the form of a proposed Board Order, will be provided to Board members. The appellant, the licensee, and parties of record are notified in advance of the date set for the Board's consideration of an appeal or request for a hearing. The appellant and the licensee will have an opportunity to address the Board at the Board meeting. The Board will decide whether to hold a hearing on appeal when one is requested before deciding the merits of the appeal. The Board's decision on appeal may be to affirm all or part, affirm with conditions, order a hearing to be held as expeditiously as possible, reverse all or part of the decision of the Commissioner, or remand the matter to the Commissioner for further proceedings. The Board will notify the appellant, the licensee, and parties of record of its decision on appeal.

II. JUDICIAL APPEALS

Maine law generally allows aggrieved persons to appeal final Commissioner or Board licensing decisions to Maine's Superior Court (see [38 M.R.S. § 346\(1\)](#); 06-096 C.M.R. ch. 2; [5 M.R.S. § 11001](#); and M.R. Civ. P. 80C). A party's appeal must be filed with the Superior Court within 30 days of receipt of notice of the Board's or the Commissioner's decision. For any other person, an appeal must be filed within 40 days of the date the decision was rendered. An appeal to court of a license decision regarding an expedited wind energy development, a general permit for an offshore wind energy demonstration project, or a general permit for a tidal energy demonstration project may only be taken directly to the Maine Supreme Judicial Court. See 38 M.R.S. § 346(4).

Maine's Administrative Procedure Act, DEP statutes governing a particular matter, and the Maine Rules of Civil Procedure must be consulted for the substantive and procedural details applicable to judicial appeals.

ADDITIONAL INFORMATION

If you have questions or need additional information on the appeal process, for administrative appeals contact the Board Clerk at 207-287-2811 or the Board Executive Analyst at 207-314-1458 bill.hinkel@maine.gov, or for judicial appeals contact the court clerk's office in which the appeal will be filed.

Note: This information sheet, in conjunction with a review of the statutory and regulatory provisions referred to herein, is provided to help a person to understand their rights and obligations in filing an administrative or judicial appeal. The DEP provides this information sheet for general guidance only; it is not intended for use as a legal reference. Maine law governs an appellant's rights.
