

SLB Methane Lidar Camera: Periodic Fugitive Methane Emission Monitoring

1 Scope and Application

1.1 Scope

This method is applicable for demonstrating compliance with the procedures in 40 CFR §60.5398b for fugitive emissions components affected facilities and compliance with periodic inspection and monitoring requirements for covers and closed vent systems, specifically demonstrating compliance through periodic screening in 40 CFR §60.5398b(b), as approved, per 40 CFR §60.5398b(d). Affected facilities could include but are not limited to, single wellhead only sites, small well sites, multi-wellhead sites, well sites with major production and processing equipment, centralized production facilities, and compressor stations.

1.2 Application

1.2.1 The application of the SLB methane lidar camera technology is per the Environmental Protection Agency's 40 CFR part 60 New Source Performance Standards (NSPS): Subparts OOOO, OOOOa, and OOOOb, and Emissions Guidelines (EG): OOOOc, for the Oil and Natural Gas Source Category.

1.2.2 The test method is applicable to methane (CH₄, CAS No. 74-82-9) emissions from oil and gas facilities. This method can be used, as approved by the Administrator, in lieu of the applicable fugitive monitoring requirements in either 40 CFR §60.5397a or §60.5397b and inspection and monitoring of covers and closed vent systems in either 40 CFR §60.5416a or §60.5416b. This test method may be used for fugitive monitoring requirements in 40 CFR §60.5397c and monitoring of covers and closed vent systems under 40 CFR §60.5416c when a state, local, or tribal authority incorporates the model rule (i.e., EG OOOOc) for the emission guidelines as part of their State Implementation Plan (SIP) or elsewhere approved as applicable.

1.2.3 The test method is a performance-based method to determine whether individual component emissions remain below prescribed thresholds.

1.3 Method Sensitivity

1.3.1 The sensitivity of this test method is a 1, 2, 3, 5, 10, or 15 kg/hr alerting threshold as applied to Tables 1 and 2 (see section 1.4).

1.3.2 This method can confirm the detection of fugitive emissions at a component-level spatial resolution (as defined at 40 CFR §60.5398b(b)(5)(iv)) and provides real imagery and video of the leak point so that an operator can visually define the emission source.

1.3.3 This method's minimum detection limit (MDL) is 0.84 kg/hr at 90% probability of detection (POD). *Note: POD is dependent on the wind speed and camera distance from the emission source. The operating envelope is defined in Table 4 of this method, and the QC metrics for each threshold are defined in Table 5 of this method.*

1.4 Data Quality Objectives

Adherence to the requirements of this method will ensure the data supporting the technology’s objective will be accurate and of quality. The technology’s objective is to screen for fugitive emissions from oil and gas sites, such as production and processing facilities, natural gas transmission and storage facilities, and natural gas gathering and boosting facilities with fugitive methane emissions that exceed the applicable alerting threshold (1, 2, 3, 5, 10, or 15 kg/hr). Screening occurs at the frequency specified in Tables 1 and 2 that corresponds to the applicable alerting threshold. This method provides an alert to an operator when the alerting threshold is exceeded that triggers a leak detection and survey response.

Table 1: Method Detection Limits and Screening Frequencies – Oil and Gas Multi-wellhead Sites, Well Sites with Major Production and Processing Equipment, Centralized Production Facilities, and Compressor Stations

Method Detection Limit	Screening Frequency
1 kg/hr	Quarterly
2 kg/hr	Bimonthly
5 kg/hr	Monthly
10 kg/hr	Bimonthly
15 kg/hr	Monthly

Table 2: Method Detection Limits and Screening Frequencies – Oil and Gas Single Wellhead Sites and Small Well Sites

Method Detection Limit	Screening Frequency
1 kg/hr	Semiannual
2 kg/hr	Triannual
5 kg/hr	Quarterly
10 kg/hr	Triannual
15 kg/hr	Bimonthly or Quarterly

2 Summary of Method

2.1 Operation and Detection Principles

This method involves the measurement of methane emissions using tunable diode lidar (TDLidar) technology, which combines aspects of tunable diode laser absorption spectroscopy (TDLAS) with differential adsorption lidar (DIAL), and time-correlated single photon counting (TCSPC) to enable remote spectroscopy and ranging with low-power semiconductor diode lasers. The methane lidar camera uses diode lasers with wavelengths around the methane absorption line at 1650.9 nm and Peltier-cooled single-photon avalanche diode (SPAD) detectors in a random modulation continuous wave (RM-CW) lidar system.

A fundamental aspect of TDLidar is the use of the high-speed laser tuning, modulation, and detection that is enabled by modern semiconductor components. This enables the laser wavelength to be scanned at rates of 1 MHz or faster and enables the rapid acquisition of images of both gas spectra and structural distance data over extended fields of view. By modulating the wavelength back and forth across the methane absorption line at 1650.9 nm, the spectrum can be reproduced and spurious effects from

ambient conditions can be negated. The camera uses a mechanically rotated Risley prism pair to rapidly scan the transmitted beam across the scene and build up an image (see Reference 7 of Section 16).

2.2 Methane Lidar Camera Measurement System

Figure 1 shows the schematic of the methane lidar camera measurement system. The electronics (i.e., the spectrometer) control the frequency of the emitted laser beam via a modulator, while simultaneously modulating the output intensity. The transceiver is switched into the transmission mode during the pulse, enabling the beam to exit the camera and penetrate the plume of methane gas while blocking off the sensitive SPAD detector to protect it from saturation. Immediately following the end of the pulse, the transceiver switches into the detection mode and opens the path to the detector. The emitted laser beam traverses the gas plume, where it is partially absorbed, and reflects off background scattering objects. Common scattering objects include ground, buildings and structures, and vegetation; no mirrors or specialized reflectors are required. The camera can image, detect, localize, and quantify emissions for methane plumes that have a background scattering surface within 200 m along the camera's line of site (i.e., the laser emitted from the camera passes through the plume and reflects off a surface that is within 200 m from the camera). A small fraction of the scattered photons return to the camera and enter the detector where they are counted, building up the raw spectrum to be used for further interpretation.

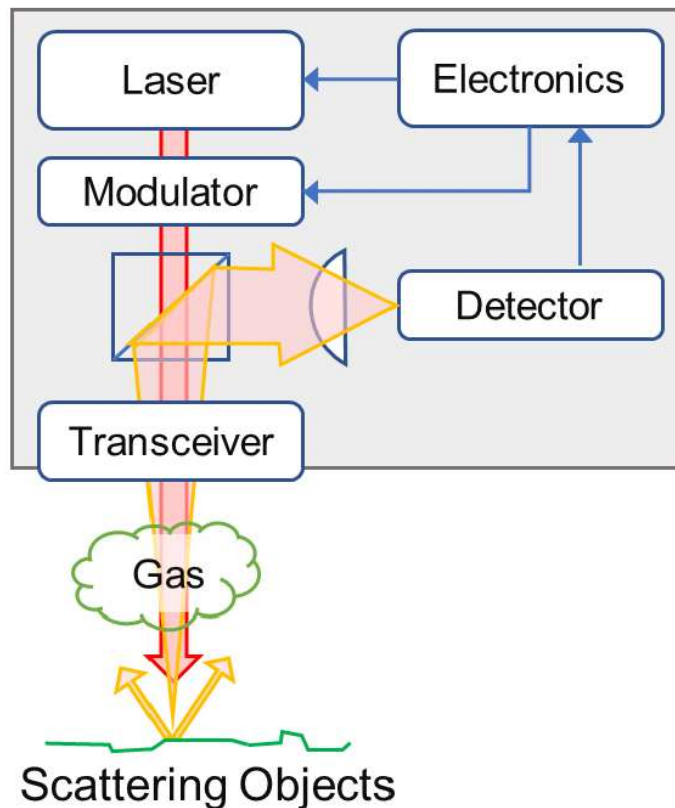

Figure 1: Schematic of the methane lidar camera (Reference 7 of Section 16).

2.3 Data Collection

This method requires mounting the methane lidar camera on a tall mast to get a vantage point above most of the equipment. The camera emits a laser beam to scan for emissions within finite fields of view and iterates through scan plans to cover all emission sources. For every scan, the camera creates images showing measurements of photon count (intensity), lidar range, computed path-integrated methane concentration, and a superimposed image of the methane concentration on the photon count. The camera uses a plume detection algorithm to detect emissions and identify continuous regions of elevated methane. Upon leak detection, the camera uses a mass balance algorithm to quantify the mass emission rate from the calculated path-integrated methane concentration and the local wind velocity obtained via an anemometer connected to the camera.

2.4 Reporting

Results of periodic screening surveys are shared with the operator within 5 calendar days of the completion of the periodic screening survey. The requirements for owner and operator monitoring and response are found and referenced in 40 CFR §60.5398b(b).

3 Definitions of Method

3.1 Definitions

- 3.1.1 2D sonic anemometer: A device using acoustic sensors to measure the wind speed and direction in two dimensions, parallel to the ground.
- 3.1.2 Emission ID: A unique numerical identifier assigned to an emitting leak that is unique in time and space.
- 3.1.3 Event: The definition of the timespan, average rate and total emission of a continuously emitting leak from a source.
- 3.1.4 Facility: A collection of sources with some relation to one another as a subdivision of an operating unit (e.g., production battery, compressor station, processing plant) defined by a physical boundary.
- 3.1.5 Field of view: A solid angle determined by the scanned laser beam exiting the lidar that sweeps out circular area or “field” in two dimensions, perpendicular to the pointing vector of the lidar. Objects within this circular area are effectively “seen” by the lidar.
- 3.1.6 Lidar: A method for determining the distance to surfaces using a laser by measuring the time for the reflected light to return to the receiver.
- 3.1.7 Lidar point cloud: A set of points created by scattering a lidar’s laser beam off a solid object in the distance and measuring the beam’s angle and object’s distance in three dimensions where each point represents a single spatial measurement on an object's surface.
- 3.1.8 Lidar signal intensity: The number of lidar laser photons scattered back and detected by the lidar’s receiver, per unit time.
- 3.1.9 Line of sight: A straight line along which the camera has unobstructed vision signal intensity.

- 3.1.10 Mass emission rate: The amount of methane by mass emitted from a source per unit time.
- 3.1.11 Measurement frame: A specific field of view determined by the pan/tilt stage (i.e. heading of the lidar) and a specific level of optical zoom of the lidar.
- 3.1.12 Methane absorption: The amount of the lidar's laser light absorbed by methane molecules within a specific wavelength band normalized to the laser's signal, where the number of molecules is directly proportional to the measured absorption.
- 3.1.13 Observation: A single image collected by the methane lidar camera. The image may or may not contain a detected methane emission.
- 3.1.14 Pan/tilt stage: A positioner or platform upon which the camera is mounted and is controlled to point the camera at a desired target, within $\sim 360^\circ$ horizontally and $\sim 180^\circ$ vertically.
- 3.1.15 Path-integrated methane concentration: The concentration of a gas in air multiplied by the distance over which it is measured, expressed in ppm \times m, or parts-per-million-meters. Here, the concentration of methane along the trajectory of the lidar's laser beam where the length is determined to be the distance from the lidar to the scattering object.
- 3.1.16 Plume: In this embodiment, an identifiable cloud of methane gas, having an origin, and eventually dispersing out into the atmosphere.

3.2 Abbreviations

- 3.2.1 ADED: Advancing development of emission detection
- 3.2.2 METEC: Methane Emissions Technology Evaluation Center
- 3.2.3 CAD: Computer-aided design
- 3.2.4 DIAL: Differential absorption lidar
- 3.2.5 Lidar: Laser Imaging Detection and Ranging
- 3.2.6 MDL: Minimum detection limit
- 3.2.7 MLM: Machine-learning model
- 3.2.8 OGI: Optical gas imaging
- 3.2.9 PCBA: Printed circuit board assembly
- 3.2.10 POD: Probability of detection
- 3.2.11 RM-CW: Random modulation continuous wave
- 3.2.12 SPAD: Single photon avalanche diode

3.2.13 TCSPC: Time-correlated single photon counting

3.2.14 TDLidar: Tunable diode lidar

3.2.15 TDLAS: Tunable diode laser absorption spectroscopy

3.2.16 TIA: Telecommunications Industry Association

4 Method Interferences and Envelope of Operation

Table 3 summarizes the method interferences and envelope of operation.

Table 3. Table summarizing the method interferences and envelope of operation.

Condition	Summary	Mitigation
Line of sight	Method requires laser beam from the camera to pass through the plume of methane and reflect off background scattering surfaces within 200 m of the camera.	Camera is mounted on a mast or existing equipment taller than the equipment to be monitored. Multiple cameras are deployed to ensure total site coverage where direct line of sight is not possible using one camera.
Highly reflective surfaces	Laser beam must reflect off a diffusive scattering object to return to the transceiver inside the camera.	Avoid installation of camera where highly reflective/mirrored surfaces are in the background; adjust the center and size of the camera's field of view if necessary.
Distance from reflecting surface	Distances exceeding threshold-dependent max distance identified in Table 4 between the camera and diffusive scattering surface can impact the amount of signal returned to the camera.	Install camera within max distance specified in Table 4 of necessary background diffusive scattering surfaces (e.g., the ground on the facility); for large facilities, install multiple cameras to ensure max distance is not exceeded.
Heavy precipitation	Heavy precipitation can temporarily decrease the detection capabilities of the camera.	Screening surveys will not occur during periods of heavy precipitation, which will cause the laser signal to fall below the 300,000 counts per second threshold.
Temperature	Temperature range for camera operation is -40°C (-40°F) to +50°C (122°F).	Periods with average temperature outside this range will not be used for periodic screening.
Minimum wind speed	Average wind speed > 0.5 m/s is necessary to provide adequate plume development.	Periods with an average wind speed < 0.5 m/s will not be used for periodic screening.

Condition	Summary	Mitigation
Maximum wind speed	Wind speeds exceeding threshold-dependent max speed identified in Table 4 can impact the sensitivity.	Periods with an average wind speed greater than those specified in Table 4 will not be used for periodic screening.
Relative humidity	Standard camera range for relative humidity is 0 to 95%.	Periods outside the operating relative humidity range will not be used for periodic screening.
Altitude	This method is appropriate for use at altitudes within the range of -400 m to 3000 m.	Method will not be deployed at sites with altitudes outside this range.
Cellular connectivity	Method requires connectivity to the cloud to transmit data for detection and subsequent alerting to emissions. LTE, wifi, and satellite are acceptable connections.	Periods with lost data due to lack of cellular connectivity will not be used for periodic screening.

Table 4. Threshold-dependent wind speed and distance envelope of operation. Minimum wind speed is 0.5 m/s under all conditions

Alerting Threshold	Max Windspeeds	Max Distance
1 kg/hr	5 m/s	100 m
2 kg/hr	10 m/s	100 m
2 kg/hr	5 m/s	200 m
3, 5, 10, 15 kg/hr	10 m/s	200 m

5 Safety

This method may not address all potential safety scenarios associated with its use. It is the responsibility of the user of this test method to establish appropriate safety and health practices and determine the applicability of regulatory limitations prior to performing this test method.

5.1 Installation

The most significant risks occur during the installation of the foundation and mast. Therefore, only trained personnel may assemble, disassemble, or otherwise interact with the system on location. Proper personal protective equipment (PPE) must be worn, including safety glasses, steel-toed shoes, hard hat, and crush-resistant gloves. The key installation risks are summarized in Table 5.

Table 5: Key risks related to system installation.

Risk	Prevention/Mitigation
Items on the ground present a tripping hazard while carrying equipment.	Keep area clean and organized throughout process. Don't attach guy wires until all equipment has been assembled onto mast. Route power cord and grounding wire out of walkways. Wear steel-toed shoes.
Pinch points are present at various times in the process.	Maintain general awareness of risk to avoid pinch points. Wear crush resistant gloves.

Repetitive motion injuries are possible, particularly when loading the ballast weight into the foundation.	Use proper lifting techniques: Don't exceed safe lifting weight, keep hardware close to body (green zone), keep back straight. Take frequent breaks.
Mast or equipment may fall while raising or lowering.	Only use lifting equipment provided with system. Clearly mark potential fall area. Communicate with all personnel in area prior to raising or lowering. All personnel in area must wear a hard hat.

5.2 Field Safety

5.2.1 In addition to risks during installation, additional risks are present during operation of the system. The key operational risks are described in Table 6.

Table 6: Key risks related to system operation.

Risk	Prevention/Mitigation
Mast may fall due to high winds.	The mast is designed to withstand potential wind loading in accordance with TIA-222 (standard that covers antenna/sensor support structures). The design has been verified by an independent third-party engineering firm. The mast may also be lowered to horizontal in case of a major weather event.
Personnel may be injured or equipment may be damaged due to electrical shock.	The mast and acquisition system are fully grounded to earth to prevent static buildup/discharge. The mast is designed to NFPA 780 for lightning protection.
The laser used in the methane lidar camera may cause eye damage.	The laser used is a class 1M (eye-safe) laser. There is no risk of eye damage unless magnifying equipment is used to look directly into the laser path. Additionally, because the laser is constantly scanning around the field of view, prolonged exposure is very unlikely to occur.

5.2.2 The system is not designed or rated (i.e., no ATEX or HAZLOC rating) for use within hazardous areas where combustible or flammable gases may be present. However, these areas may still be monitored by the methane lidar camera provided the camera and support equipment are in a safe area.

6 Equipment and Supplies

The key system components for this test method are illustrated in Figure 2 and described below, where the left image illustrates the connectivity diagram of components, and the right image shows the full system as assembled in the field.

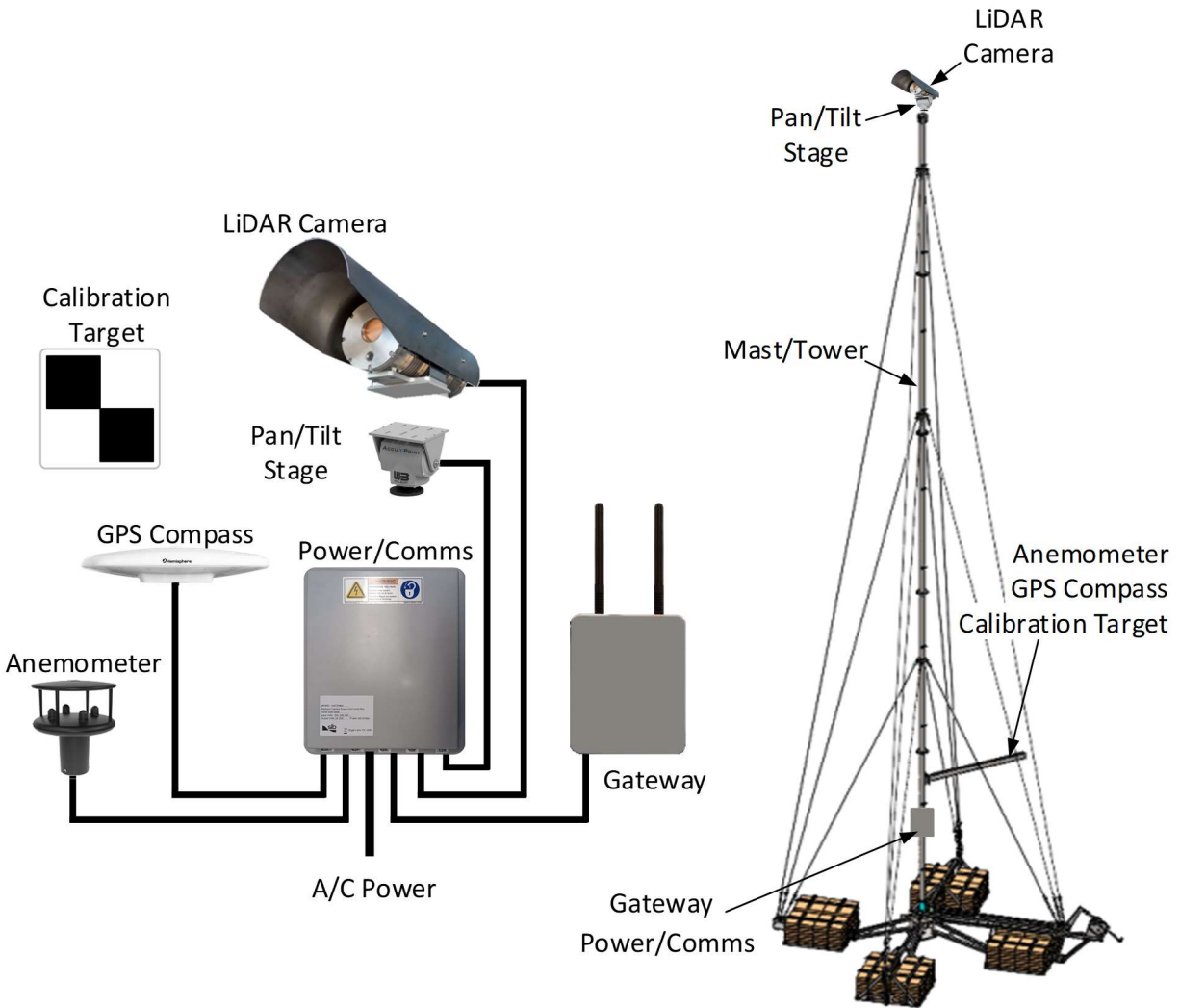

Figure 2: Acquisition system connection diagram and key components, and 3D view of the complete system.

- 6.1 **Methane lidar camera**—Once directed to an emission source and stationary, the camera uses two prisms to scan a conical field of view while pulsing a laser. The laser return signal provides time of flight (for lidar range calculation), signal intensity, and path-integrated methane concentration. This information is used to detect and quantify methane leaks, and to produce images for leak evaluation.
- 6.2 **Pan/tilt stage**—The camera sits on a pan/tilt stage that is used to control the nominal direction of the camera (i.e., center of field of view), directing the camera to the different emission sources. The camera is typically mounted above the emissions source, and the stage pans 360° degrees and tilts down to image the sources.
- 6.3 **Power and communications enclosure**—This enclosure assembly serves as the power and networking hub for the acquisition system. The enclosure does not contain a CPU or perform any local control, and all communication is through wired cables and connections. Features include LEDs to serve as diagnostic indicators, remotely operated relays to control camera and sensor

power, ambient temperature measurement (outside enclosure), and dedicated grounding lug to ensure proper earth grounding.

- 6.4 **Gateway**—The Delfi™ digital platform gateway includes a cellular modem, Wi-Fi, and ethernet connectivity to provide secure bidirectional communication with the cloud. The gateway is responsible for local control of the stage and camera, and data aggregation from the various sensors. Other connectivity options are available.
- 6.5 **GPS compass**—The compass incorporates two GPS sensors that are used to provide location (i.e., latitude and longitude), as well as heading (referenced to true north). This information is combined with the location information of the monitored equipment to attribute leaks to the correct equipment. The heading data, in conjunction with the calibration target, also enables the system to automatically determine the orientation of the camera and anemometer.
- 6.6 **Calibration target**—The target consists of a black-and-white grid on a metal plate. It is located on a sensor boom near the bottom of the tower. When the camera scans around the base of the tower, it can locate the target and determine the orientation of the sensor boom. This orientation then enables the system to determine the heading of the camera and wind data.
- 6.7 **Anemometer**—The anemometer provides wind speed and direction, which is required to calculate the methane mass emission rate. The anemometer includes an internal heater to prevent ice buildup that would otherwise affect the measurement. The anemometer is typically mounted at a height of about 3 m, depending on the installation details. While this height may not correspond exactly to the elevation of the methane source, the wind variation with height will introduce only a small correction to the calculated mass emission rate that can be accounted for in the interpretation. The anemometer must provide wind speed and wind direction at an accuracy of 10% RMSE at 12 m/s.
- 6.8 **Mast/tower**—The tower (sometimes called mast) provides the support structure for the camera and acquisition system. It is typically 15 m high and capable of withstanding high wind speeds. The tower may incorporate guy wires that can be secured to the foundation of the tower to minimize the footprint and eliminate the need for ground penetrations. Other variations may be used to support the methane lidar camera, as well as existing structures in some cases.

7 Reagents and Standards

The camera hardware contains a sealed gas cell pre-calibrated from 500 to 800 ppm methane concentration to confirm that the laser is continuously locked in around the methane absorption wavelength of 1650.9 nm. The lower explosive limit (LEL; lowest percentage concentration of methane in air capable of producing a flash fire in the presence of an ignition source) of methane is 5%, which is 50,000 ppm (Ohio Department of Health, 2012). The gas cell concentration is 2 orders of magnitude lower than the LEL and does not pose an ignition risk.

No other reagents are involved in this method.

8 Data Collection and Method Input Sourcing

Table 7. Data inputs collected for this method

Instrument/Source	Variables	Use
Lidar Camera	High frequency laser data	Raw laser data processed to generate methane concentration data and QC metrics
Lidar Camera	Total lidar signal	Used to provide localization of emission source at component-level
Lidar Camera	Lidar range	Used to provide localization of emission source at component-level
Anemometer	Wind direction and speed	Meteorological data used in model for localization and quantification of emissions

8.1 Data Collection

Data collection and management are described in this section. The procedures for planning, placement, and installation of the equipment listed in Section 6 are described in Appendix I. The operation of equipment, collection of data, and data processing occurs according to the following procedures. All steps in this process are automatic and are managed by SLB, unless otherwise noted.

- 8.1.1 The equipment listed in Section 6 is installed per the procedures in Appendix I.
- 8.1.2 Prior to each periodic screening survey, the camera QAQC checks are run to ensure all equipment is present in the defined scan frames and the methane concentration is within 10% of the internal calibration cell, as specified in Table 8.
- 8.1.3 A periodic screening survey is initiated based on the operator's monitoring plan in accordance with 40 CFR §60.5398b(b)(2).
- 8.1.4 The start of the periodic screening survey is noted as a date and time.
- 8.1.5 The lidar camera scans the facility according to the scan plan, covering all fugitive components, covers, and closed vent systems. The scan plan tells the lidar camera where each frame is located and in what order to capture a frame.
- 8.1.6 The lidar camera captures a frame approximately every 5 minutes until the camera has captured frames covering the entire facility. Depending on the size of the facility, this process can take 2 to 3 hours.

- 8.1.7 If methane is detected in a frame, the camera automatically takes a confirmation image with the detection centered in the field of view.
- 8.1.8 A periodic screening survey consists of 3 complete scans of the facility (i.e., 3 frames for every field of view).
- 8.1.9 Every frame is transmitted immediately to the cloud. Frames contain all raw data for processing and system health data for QC checks (see Section 9).
- 8.1.10 Health metrics are evaluated throughout the periodic screening survey. The health metrics cover power, connectivity, and function (see Section 9).
- 8.1.11 In the rare case connectivity to the cloud is lost, the lidar camera will buffer all scan frames taken to be retransmitted when connectivity is reestablished.
- 8.1.12 A periodic screening survey, consisting of 3 complete scans with 100% site coverage, must be completed within 5 days of initiating the survey. Surveys that take more than 5 days (120 hours) will trigger an evaluation to determine if corrective action is required (equipment repair, equipment replacement, re-siting, etc.).
- 8.1.13 If the periodic screening survey cannot be completed within the required 5 days, the operator is notified and required to complete an OGI or Method 21 survey for the entire facility as outlined in 40 CFR 60.5397b

8.2 Data Processing

- 8.2.1 Raw data from the methane lidar camera is processed to calculate the mass emission rate, as outlined in Section 12.
- 8.2.2 The median mass emission rate of the 3 frames for each field of view is calculated. The median mass emission rate for all fields of view are summed to compute a site-wide emission rate. The calculated site-wide emission rate is compared to the applicable detection threshold specified in the operator-defined monitoring plan.
- 8.2.3 Median mass emission rates and leak locations for emissions attributed to fugitive emissions components, covers, and closed vent systems are reported to the operator in the periodic screening report.

8.3 Data Management

- 8.3.1 Raw data from sensors are acquired, timestamped, labelled, and packed into version-controlled binary payloads that ensure data integrity. Well-defined schemas guarantee efficient transmission and data consistency.
- 8.3.2 All data in transit from the edge to the cloud is protected using a state-of-the-art and widely adopted security protocol, the transport layer security (TLS). This enables the parties to create a secure session, validating the identity of the actors, and exchanging encryption keys that will be used to ensure the integrity of the transmitted data.

- 8.3.3 In case of communication failures interrupting the flow of data between edge devices and the cloud, edge devices can buffer data for several days until communication is restored, increasing the resiliency of the system to mobile data outages or intermittent communications in remote areas.
- 8.3.4 Data received from edge devices are deserialized, labelled, and automatically segregated into separate tenants (data partitions) per customer. Data are stored in encrypted databases using AES-256, the encryption standard recommended by the US government for confidential data.
- 8.3.5 All data fed into interpretation algorithms goes through data quality gates that check for outliers, out-of-range data, or invalid data. Only valid data are used for detecting, localizing, and quantifying emissions.
- 8.3.6 All raw, intermediate, and processed data are regularly backed up to at least two regions. Multiple copies are retained, allowing the system to be restored to several days in the past.
- 8.3.7 All data in transit are encrypted using the TLS security protocol. Data at rest are encrypted with a symmetric encryption algorithm that uses a 256-bit key (AES-256).
- 8.3.8 Cloud operations are executed according to the Service Organization Control Type 2 (SOC 2) standard and audited annually. SOC 2 is a cybersecurity compliance framework developed by the American Institute of Certified Public Accountants (AICPA). SOC 2 provides controls that cover key areas, such as security, availability, processing integrity, and confidentiality.

9 Quality Control

This section describes the quality-control measures implemented throughout the system to secure the ability to consistently deliver a quality result. Quality-control checks for the lidar camera cover the edge device (ensuring the laser wavelength is locked and an accurate image is acquired), the data transmission (ensuring security and no losses), the cloud (ensuring all data are captured securely and the interpretation runs without failures), and the manufacturing process (adhering to all quality and compliance requirements).

Table 8. Quality control acceptance criteria and corrective actions for this method

Instrument	Measurement	Acceptance Criteria	Frequency Checked	Corrective Action
Camera	External Laser Power	<10mW	Each unit, During manufacturing	Repair or replace
Camera	Lidar return signal intensity	>3,000,000 counts per second against fixed target at 185m	Each unit, During manufacturing	Repair or replace
Camera	Detector Saturation Signal Threshold	>10,000,000 counts per second	Each unit, During manufacturing	Repair or replace
Camera	Backscatter signal intensity to ensure no debris on	<300,000 counts per second	Each unit, During manufacturing	Repair or replace

Instrument	Measurement	Acceptance Criteria	Frequency Checked	Corrective Action
	camera window or obstacle in front of camera			
Camera	Distance measurement	Measurement within 1m of known distance	Each unit, During manufacturing	Repair or replace
Camera	Scanner image calibration	0.5deg resolution accuracy	Each unit, During manufacturing	Repair or replace
Camera	Locked laser wavelength	Absorption maximum for methane detected within laser frequency scanning range	Each unit, During manufacturing	Repair or replace
Camera	Locked laser wavelength	Laser sub-mount temperature within +/-0.15degC range	Each unit, During manufacturing	Repair or replace
Camera	Measured concentration path length variance over set concentration path lengths	R ² value > 0.997	Each unit, During manufacturing	Repair or replace
Camera	Measurement reference to external gas cell	Measure concentration to within 10% accuracy	Each unit, During manufacturing	Repair or replace
Camera	Concentration path length stability over temperature variation	<8 ppm.m/degC over 30degC temperature rise	Each unit, During manufacturing	Repair or replace
Camera	Concentration path length measurement stability (Allan Deviation)	<15ppm.m @ 5,000,000 counts per second of received signal <35ppm.m @ 5,000,000 counts per second of received signal	Each unit, During manufacturing	Repair or replace
Camera	Internal moisture content	Dewpoint of internals below - 40degC	Each unit, During manufacturing	Repair or replace
Camera	Enclosure seal integrity	Withstands 5psi internal pressure, no	Each unit, During manufacturing	Repair or replace

Instrument	Measurement	Acceptance Criteria	Frequency Checked	Corrective Action
		air leaks visible over 10min in dunk tank		
Anemometer	Anemometer outside wind shadow	Anemometer mounted above obstacles on site or at distance from all obstacles > $3B_s^{2/3}B_L^{1/3}$, where B_s is the smaller of the obstacle height/width and B_L is the larger (and is capped at $8B_s$)	Initial siting and re-siting evaluation as needed	Re-siting evaluation
Camera	Distance between camera and background reflective source	Maximum distance 200 m	Initial siting and re-siting evaluation as needed	Re-siting evaluation
Camera	Line-of-sight	No obstacles between camera and at least part of the methane plume	Initial siting and re-siting evaluation as needed	Re-siting evaluation
Power and Communications Box	Ambient Temperature	-20°C (-40°F) to +50°C (122°F)	Every concentration measurement	Temporarily suspend data collection
Camera	Subsystem Voltages: <ul style="list-style-type: none"> Power PCBA Pantilt Detector Scanner 	All 21 – 25 V	Every 10s during operation	Reset, Repair or Replace
Camera	Subsystem Voltages: <ul style="list-style-type: none"> Power PCBA Pantilt Detector Scanner 	<ul style="list-style-type: none"> < 2 A < 1 A < 0.2 A < 0.2 A 	Every 10s during operation	Reset, Repair or Replace
Camera	Scanner Servos Active	ACTIVE	Every 10s during operation	Reset Scanner, Repair or Replace
Camera	Thermo-Electric Coolers: <ul style="list-style-type: none"> Laser Modulator 	All ACTIVE	Every 10s during operation	Temporarily suspend measurement,

Instrument	Measurement	Acceptance Criteria	Frequency Checked	Corrective Action
	<ul style="list-style-type: none"> • Detector 			Reset, Repair or Replace
Camera	Internal relative humidity to check for moisture ingress	<95%	Every concentration measurement	Repair or replacement of camera
Camera	Internal CPU temperature	-10°C to +70°C	Every concentration measurement	Temporarily suspend data collection
Camera	Presence of calibration target	Calibration target present	Initial siting and re-siting evaluation as needed	Install new calibration target
Camera	Presence of equipment in each scan frame	Correct equipment is present in each scan frame	Prior to each periodic screening event	Realign camera using calibration target
Camera	Lidar return signal intensity	>300,000 counts per second	Every concentration measurement	Temporarily suspend data collection
Camera	Calibration spectrum	Spectral lineshape visible and within limits	Every 10s during operation	Temporarily suspend data collection
Camera	Backscatter signal intensity to ensure no debris on camera window or obstacle in front of camera	<10,000,000 counts per second	Every 10s during operation	Temporarily suspend data collection
Camera	Laser drift to ensure wavelength stability over system lifetime	Laser temperature within 0.12 degrees C of commissioned value	Every 10s during operation	Reset laser
Power and communication box	Communications Links	ACTIVE	Every 10s during operation	Temporarily suspend data collection
Anemometer	Anemometer Active	ACTIVE	Every 10s during operation	Temporarily suspend data collection
Anemometer	Wind speed in measurable range	Wind speed < 10 m/s and wind speed > 0.5 m/s	Every concentration measurement	Temporarily suspend data collection
Camera	Methane concentration in internal cell	Concentration within 10% of original value	Prior to each periodic screening event	Temporarily suspend measurement,

Instrument	Measurement	Acceptance Criteria	Frequency Checked	Corrective Action
				Reset, Repair or Replace

10 Calibration and Standardization

10.1 Calibration Procedures

As described in Section 9.1, the lidar camera and the entire acquisition chain, including all the optics and electronics, do not require any field calibration. All the lidar camera systems are both passively and actively stabilized to correct for any drifts caused by changing environmental effects or aging. Only the installation geometry and interpretation steps dependent on it require calibration as described below. The lidar camera system installation workflow is outlined in Appendix I.

10.1.1 The installation geometry must be calibrated to account for any potential misalignments or tilts. To correctly identify the source of methane emissions detected by the camera, the measured pan angle of the monitoring system's pan/tilt stage must be converted to a heading angle of the camera's line of sight with respect to geodetic north. The conversion from pan to heading angle establishes the position of the leak relative to the camera in a fixed coordinate reference system. To compute the offset between the measured pan and heading angles, a calibration target with high optical contrast is mounted on an arm rigidly attached to the camera mast and perpendicular to it. A dual-antenna GPS is also attached to this arm. The difference between measured pan angle and heading with respect to north is computed by subtracting the reported pan angle while observing the high-contrast target from the heading measured by the GPS. Further corrections are made in case of any slight warping or leaning of the mast that may cause the measured tilt angle of the stage to differ from the pitch angle of the line of sight relative to the horizon.

10.1.2 After the camera is deployed, a calibration scan plan is executed. The calibration scan consists of lidar measurements at high tilt angles (aiming at the ground close to the camera) that serve the dual purpose of locating the calibration target and taking measurements of the lidar range to points on the ground near the mast, which can be used to adjust for slight mast warping or leaning, assuming that the ground in the immediate vicinity of the mast is level. In case the calibration target is missing or mislocated or unreadable for whatever reason, the software will flag this situation, and a replacement will be installed.

10.1.3 Following the installation geometry calibration scan, the workflow for localization of the emission sources is also calibrated. To that end, a full panoramic scan is taken. The panoramic scan returns intensity and lidar range images covering heading angles up to a range of 0 to 360° and pitch angles up to a range of 0 (horizon) to almost 90° (downward). A complete panoramic image can be produced either from intensity measurements or range measurements; and is used to verify whether equipment is in the camera's field of view and to prescribe the optimal direction and zoom of the operational scan plan frames to monitor all potential leak sources.

10.1.4 The panoramic image may also be used to label potential leak sources. A person familiar with the layout of the site may be able to identify equipment simply by viewing it in the panorama, or

the position of equipment in the panorama may be compared against satellite images, aerial drone images, ground-based photographs, or site schematics. The labels of potential leak sources are shown when reporting leaks. The spatial extents of different potential leak sources are used to track distinct and possibly simultaneous leaks during emission lifecycle analysis.

- 10.1.5 The orientation of the camera is verified prior to each periodic screening event. The camera completes one tour of the site, and each scan frame is checked to ensure the correct potential emission source(s) is included in the individual scan frame established during installation (see Appendix I). If the entire potential emission source, or a portion of the source, is missing from the scan frame, then it indicates the camera's position has shifted. The camera would then be realigned following the procedures in section 10.1.1 prior to conducting the periodic screening survey.
- 10.1.6 The anemometer is factory calibrated by the manufacturer and does not require any regular field calibration or maintenance for 10 years as per manufacturer requirements. After this period, the anemometer needs to be recalibrated or replaced to maintain reliable performance. The functionality of the anemometer is verified by a QAQC check for every survey.

10.2 Standardization: Training Requirements

Only specialized and trained SLB personnel or contractors are allowed to manufacture and calibrate SLB lidar cameras. The training procedures, requirements, and standard operating procedures are held by SLB.

11 Analytical Procedure

[Reserved]

12 Detection and Alerting

12.1 Detection

For the purposes of this test method, detection is defined as the exceedance of measured emissions above the applicable alerting threshold value. Operators will select the alerting threshold and corresponding frequency of scans based on Tables 1 and 2 of 40 CFR Part 60, Subpart OOOOb.

- 12.1.1 The lidar camera is set up with a scan plan, designed to cover all applicable sources at the site, and will cycle through the scan plan until 3 frames are generated for each field of view.
- 12.1.2 Ambient methane concentrations are removed by subtracting the calculated ppm-m of ambient methane using an ambient methane concentration of 2 ppm and the range (in meters) measured between the lidar camera and the background.
- 12.1.3 A plume detection algorithm is used to identify and separate large, connected regions of elevated methane. The image of the plume is overlain on a background image, allowing the methane emissions to be allocated to a particular source.
- 12.1.4 A mass balance using Gauss' Law is used to calculate the methane mass emission rate.
- 12.1.5 The median mass emission rate for each field of view is calculated.

12.1.6 Median mass emission rates for each field of view are summed to calculate a site-wide emission rate estimate.

12.1.7 A site-wide emission rate estimate that is at or below the relevant alerting threshold (1, 2, 3, 5, 10, or 15 kg/hr) is a non-detection. A site-wide emission rate estimate that is above the relevant alerting threshold is a detection.

12.2 Alerting

12.2.1 Upon completion of the periodic screening survey, the data is processed as described in Section 15.3 to determine if the site-wide emission rate estimate exceeds the relevant alerting threshold (1, 2, 3, 5, 10, or 15 kg/hr). A report is provided to the operator that specifies the location and emission rate for all component-level emissions.

12.2.2 Exceedances of the alerting threshold require component-level follow up by the operator per 40 CFR §60.5398b(b)(5)(iv).

13 Method Performance

The performance of the methane lidar camera, in particular its limit of detection, depends on a variety of operational and environmental conditions. Within the operational envelope, the two factors that most strongly impact performance are distance and wind speed. The camera can make accurate measurements for distances between the camera and the reflecting surface below 200 m, although the limit of detection becomes larger as the distance increases within that range. Similarly, the limit of detection becomes larger as the wind speed increases and the methane is more quickly blown out of the field of view.

During the 2023 advancing development of emission detection (ADED) tests at METEC (Ilonze et al., 2024), when the performance was tested under a wide range of operational and environmental conditions, the methane lidar camera was shown to have a site-level limit of detection of 0.40 kg/h at 67% probability of detection, and a site-level limit of detection of 0.84 kg/h at 90% probability of detection. The range of limits of detection, including explicit dependence on distance and wind speed, are shown in Table 4.

14 Pollution Prevention

The sensor used in this alternative test method does not discharge anything to the environment. The sensor may generate scope 2 emissions because it uses whatever power source is being used on the rest of the site.

15 Data Management and Recordkeeping

15.1 Data Collection and Generation

15.1.1 The methane lidar camera is commissioned to continuously scan all possible methane emission sources. This is done in the form of a scan plan that takes snapshots (frames) of possible emission source at regular intervals. A frame is generated approximately every 5 minutes, which is the time it takes the laser to scan the area of interest (camera field of view). Once a

scan plan has been activated, the camera will loop through each of the targets (frames), looking for methane plumes and if detected, then it will quantify and attribute the origin of the plume to a known source. Every time a frame is acquired, environmental data are also measured, appended, and transmitted to the cloud. In the cloud, data integrity and quality are verified and then passed to interpretation algorithms that detect, quantify, and attribute emissions to sources. The processing is done at a faster rate than the time it takes to acquire each frame.

15.1.2 In addition to gas concentration data, system health metrics such as CPU load, memory consumption, auxiliary systems health (anemometer, GPS, etc.), among others, are collected. Diagnostic data are transmitted regularly to the cloud and used to detect issues at the edge, enabling remote troubleshooting and sending alarms in case of system degradation.

15.2 Data Management and Storage

15.2.1 Raw data containing methane concentration, photon count, distance, wind speed, and wind direction are serialized and packaged in a strongly typed structured format. The file structure defines the communication schema between the edge and the cloud, and it is version controlled to trace the evolution of the schema, enabling backward-compatibility. The payload is compressed and encrypted before being transmitted over a secured channel to the cloud using the industry-standard transport layer protocol.

15.2.2 Data are transmitted on demand, every time a frame is generated, which is usually every 5 minutes. When data are received in the cloud, files are routed to separate tenants per operator and persisted in file stores that are encrypted using a symmetric block cypher with 256-bit key lengths (AES 256). Raw data are immutable, which allows recovery from downstream failures in the processing pipeline and provides traceability. All raw data are periodically backed up several times a day to at least two regions. Multiple copies of past backups are retained, providing a layered approach to restore to predetermined points in time in the past for up to several days.

15.3 Data Processing

15.3.1 Data processing is done automatically every time a new frame is received in the cloud from the edge. In the case of communication failures, the edge can buffer data for several days and when communications are restored, buffered data are transmitted in order.

15.3.2 After raw data from the edge systems are ingested, it is unmarshalled and passed to a processing pipeline that checks for data integrity and applies quality checks such as data out of range, outliers, missing data, and sensor data. If data quality checks are passed, data are fed to interpretation algorithms that will detect if a plume is present in the image. If so, it will estimate the flow rate of the emission and attribute the plume origin to a known emission source at the site. The processing pipeline also creates 1) images showing methane concentration, photon count, range and 2) a compound image overlapping the photon count and the methane concentration. These enable users to confirm the interpretation from algorithms and are kept as evidence of the raw data. The overlapping of methane concentration over intensity and range are useful information for identifying where a gas plume originated.

15.3.3 Connectivity and system health metrics such as data transmission frequency and data quality are computed regularly, aggregated at site level, and used for determining system availability. Data quality checks analyze data feeds and validate that data are arriving at the required

frequency, data are changing and within expected ranges and checks for invalid data. These checks are used to confirm power and function of the system and calculate health indicators during the periodic screening survey. This provides an easy way to demonstrate system compliance with regulatory requirements.

15.4 Recordkeeping Procedures

15.4.1 Processed data is maintained for a period of 5 years as specified in 40 CFR §60.5420b(c).

15.4.2 Dates of minor revisions to the detection and quantification algorithm of the methane lidar camera technology will be recorded by SLB and made available upon request. Major changes to the detection and quantification algorithm or the methane lidar camera technology must be submitted to EPA for review prior to implementing the change(s) in the field. Major and minor changes to the detection and quantification algorithm are determined by reprocessing the original validation data with the updated algorithm and comparing those results to the original results.

16 References

1. Ai, X. and Titchener, J. "Method to Determine Gas Absorption in Rapidly Tuned Diode Lidar." U.S. Patent No. US 11,714,047 (August 1, 2023).
2. Ai, X., Titchener, J., and Dunning, A.: "Method of Operating a Lidar System for Detection of Gas," US Patent No. US11644576B2 (May 9, 2023).
3. Ilonze, C., Emerson, E., Duggan, A., and Zimmerle, D.: "Assessing the Progress of the Performance of Continuous Monitoring Solutions under Single-Blind Controlled Testing Protocol," *ChemRxiv* (2024), <https://doi.org/10.26434/chemrxiv-2023-8bfgm-v2> (preprint).
4. Ohio Department of Health: "Methane: Answers to Frequently Asked Health Questions," Bureau of Environmental Health, Health Assessment Section (2012). <https://semspub.epa.gov/work/05/437170.pdf>.
5. Ostaszewski, M., Harford, S., Doughty, N., Hoffman, C., Sanchez, M., Gutow, D., and Pierce, R.: "Risley Prism Beam Pointer," *Proc. SPIE 6304, Free-Space Laser Communications VI*, 630406 (2006), <https://doi.org/10.1117/12.679097>.
6. Reed, M. K. and Ai, X.: "Measurement of Gas Flow Rate," US Patent Application Publication No. 2023/0324430 A1 (October 12, 2023).
7. Titchener, J., Millington-Smith, D., Goldsack, C., Harrison, G., et al.: "Single Photon Lidar Gas Imagers for Practical and Widespread Continuous Methane Monitoring," *Applied Energy* (2022) 306 (Part B), 118086. <https://doi.org/10.1016/j.apenergy.2021.118086>.
8. Titchener, J. and Ai, X.: "Rapidly Tuneable Diode Lidar," UK Patent No. GB2586075A (July 28, 2021).

17 Tables, Diagrams, and Flow Charts

[Reserved]

Appendices

I. Siting Information

Planning:

1. Sites using this test method are identified by the operator.
2. SLB creates a 3D model of the site that includes the location and height of all equipment onsite. This model is created through the use of elevation data from publicly available information (e.g., USGS 3DEP Lidar Explorer), operator provided lidar surveys or other methods such as photogrammetry, computer-aided design (CAD) data, by extruding equipment located on an aerial image to a defined height, or other means.
3. SLB provides the operator with the 3D model and the operator identifies the equipment with fugitive emissions components, covers, and closed vent systems (“potential emission sources”) and potential camera locations where it is safe and feasible to position the camera. For camera positions the ground must be acceptable to install a mast, power must be available, and the position must minimize interference with site operations.
4. Using the information in step 3, SLB identifies a series of possible camera positions and camera installation heights, ensuring that potential emission sources are within 200m from each possible camera position and the camera is mounted higher than all fugitive components, covers, and closed vent systems. A panoramic image is generated to ensure that no other equipment/building on the site significantly obscures line-of-sight.
 - a. As an example, the top and middle images in Figure 3 represent equipment level coverage for two camera locations shown by star markers. The location in the top image only covers 77% of the equipment in the facility and is unacceptable. The location in the middle image covers 100% of the equipment and is allowable for camera installation. To identify the best location, the facility is discretized into hexagons where each hexagon is a potential camera location and the equipment-level coverage for each location is computed. As shown in the bottom image of Figure 3, some locations provide 100% coverage (yellow hexagons) while other locations do not (nonyellow hexagons).
5. Acceptable locations for camera placement include those that achieve 100% coverage of all required sources.
6. If no single location can achieve 100% coverage, then step 4 is repeated by adding additional camera(s) and optimizing all camera locations to achieve 100% coverage.
7. This methodology may be performed manually or digitally.
8. SLB provides a final site plan to the operator noting the location of each camera and potential emission source covered by the test method.
9. If equipment is added, removed, or relocated on the site, then the steps in this siting procedure must be followed to ensure existing camera placement provides 100% coverage of all required sources or to identify the placement of additional camera(s) to achieve 100% coverage.

Overall Coverage: 77.3%



coverage (%)



Overall Coverage: 100.0%



coverage (%)



coverage (%)

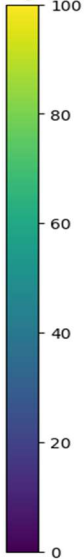

Figure 3: (top and middle) Lidar camera planning showing equipment-level coverage for two proposed camera locations on the same site. The star indicates a proposed camera location, and the color scale shows coverage for each equipment unit for a camera installed at the starred location. In the top and middle images, only the equipment to be monitored by the camera is colored, and the color represents the ability of a camera at the starred location to detect and quantify emissions at the equipment unit. The camera location in the top image only covers 77% of the equipment in the facility and is unacceptable. The camera location in the middle image covers 100% of the equipment and is allowable for camera installation. (bottom) Each hexagon is a potential camera location while the color of the hexagon indicates overall coverage of all sources on the site from a camera installed at that location.

Installation:

1. Installation of the camera and its ancillary equipment is conducted by SLB and its representatives with camera(s) placed as specified in the final site plan.
2. Install camera within 200 m of necessary background diffusive scattering surfaces (e.g., the ground on the facility); for large facilities, install multiple cameras to ensure 200 m distance is not exceeded.
3. The camera is mounted on a mast or other structure (e.g. crane, lighting tower, etc.) at a height above all fugitive components, covers, and closed vent systems and according to SLB's proprietary installation manual.
4. Health and safety considerations are the main driver to ensure safe installation and operation of the system, as described in Section 5.
5. Once installed, SLB executes the calibration scan specified in section 10.1.2.
6. SLB generates a scan plan for the site by taking a panoramic image of the site, identifying the potential emission sources (equipment with fugitive emissions components, covers, and closed vent systems), and defining a series of frames that include each of these sources. The series of frames becomes the scan plan used to complete periodic surveys of the site using this test method. The scan plan tells the lidar camera where each frame is located and in what order to capture a frame. Each frame takes approximately 5 minutes to generate before moving to the next frame.

II. Example Site Monitoring Plan

This site monitoring plan outlines the response actions that the owner/operator must perform in response to periodic screening results from the use of this alternative test method (SLB Methane Lidar Camera: Periodic Fugitive Methane Emission Monitoring).

All procedures for periodic screening must be followed as described in SLB Methane Lidar Camera: Periodic Fugitive Methane Emission Monitoring.

1. Response Requirements for use of SLB Methane Lidar Camera: Periodic Fugitive Methane Emission Monitoring:

SLB will deliver the results of the periodic screening survey within 5 calendar days of the end of the periodic screening event. The results include the following information:

Variable	Units	Description
Screening Result	Yes/No	Indicator of detected emissions
Estimated Site-Level Emission Rate	kg/hr	Numerical value of median total site-wide emissions during the screening event
Estimated Component-Level Emission Rate	kg/hr	Numerical value of the median emission rate of the individual component(s) identified with emissions during the screening event. A separate estimate is provided for each individual leak identified.
Component Identification	Photograph	Digital image of the individual component(s) identified with emissions during the screening event. A separate photograph is provided for each individual leak identified.
Screening Threshold Value	kg/hr	Numerical value of the screening threshold per table 1 or 2 of 40 CFR Part 60, subpart OOOOb, based on the frequency of screening surveys in 40 CFR 60.5397b(g)(1)(i) - (v)
Screening Start Date/Time	Date/Time	Start date and time of the periodic screening event
Screening End Date/Time	Date/Time	End date and time of the periodic screening event

Periodic Screening Event Duration	Days, Hours, Minutes	Total duration from start to end of the screening event
Fugitive Emission Screening Duration	Hours, Minutes	Cumulative duration of valid measurements in screening event
90% PoD	kg/hr	Numerical value of the 90% Probability of Detection value representative of the screening event

The site plan is maintained by the owner/operator to demonstrate the location of each methane lidar camera and potential emission source for the site. When equipment is added, removed, or repositioned, the site plan must be evaluated and updated as necessary. This is performed by SLB.

If the median site-level emissions exceed the applicable alerting threshold for the site, the owner/operator must initiate a follow-up inspection/investigation to make repairs. A detection at the component-level triggers a follow-up inspection by the owner/operator as required in 40 CFR 60.5398b(b)(5)(iv), as follows:

1. The owner/operator conducts a monitoring survey of all fugitive emissions components located within 1m radius of the location of the periodic screening detection using either OGI or EPA Method 21 and following the procedures in the owner/operator company-defined monitoring plan.
2. If the detection occurred in a portion of the site containing a storage vessel of a closed vent system, the owner/operator must inspect all covers and closed vent systems connected to all storage vessels that are within a 0.5m radius of the location of the periodic screening detection by inspecting the whole system connected to the portion of the system in the radius of the detected event.
 - a. Covers and closed vent systems must be inspected with OGI or Method 21.
 - b. Covers and closed vent systems must have a visual inspection to identify defects.

Additional requirements for repair, recordkeeping, and reporting apply to the owner/operator and must be included in the company-defined monitoring plan required by 40 CFR 60.5398b(b)(2).