

Municipality/Organization: City of Fitchburg
EPA NPDES Permit Number: MAR041189
MassDEP Transmittal Number: W-035345
Annual Report Number & Reporting Period: Year 15
April 1, 2017 – March 31, 2018

NPDES PII Small MS4 General Permit Annual Report (Due: May 1, 2018)

Part I. General Information

Contact Person: Nicholas Erickson, PE Title: Civil Engineer
Telephone #: 978-829-1905 Email: nerickson@fitchburgma.gov
Mailing Address: Fitchburg Department of Public Works, 301 Broad Street, Fitchburg, MA 01420

Certification:

I certify under penalty of law that this document and all attachments were prepared under my direction or supervision in accordance with a system designed to assure that qualified personnel properly gather and evaluate the information submitted. Based on my inquiry of the person or persons who manage the system, or those persons directly responsible for gathering the information, the information submitted is, to the best of my knowledge and belief, true, accurate, and complete. I am aware that there are significant penalties for submitting false information, including the possibility of fine and imprisonment for knowing violations.

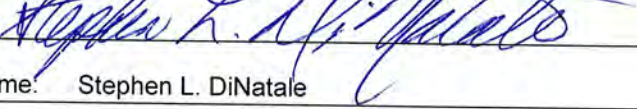
Signature: 
Printed Name: Stephen L. DiNatale
Title: Mayor
Date: May 1, 2018

Part II. Self-Assessment

The City of Fitchburg has completed the required self-assessment and has determined that at the end of the Permit Year 15 reporting period, the City was in compliance with all provisions of the approved NOI, except for the following:

Part III PC-3: Operation and maintenance agreement to inspect existing stormwater BMP's at post construction sites.

During previous permit years, the Department of Public Works, Engineering Division (DPW Engineering) began development of a City ordinance requiring private owners of permanent stormwater BMPs to maintain their stormwater infrastructure. Due to a lack of internal resources, this ordinance was never finalized and consequently was never adopted by the City. During Permit Year 13, DPW Engineering developed a spreadsheet linking privately-owned stormwater BMPs to the Operation & Maintenance plans submitted to the City during their respective planning and permitting processes. The City plans to use this spreadsheet to track and enforce maintenance requirements once an ordinance is finalized and adopted by the City. This spreadsheet will be updated as needed. During Permit Year 15, DPW Engineering was successful in securing a small amount of funding for its MS4 program. The City contracted Arcadis to perform a review of the City's stormwater ordinances and provide recommendations for updates/revisions to ensure the City meets the requirements of both the 2003 and 2016 MS4 permit requirements. This project is ongoing, and will likely conclude during Year 1 of the new MS4 permit. Please see **Attachment 1** for an interim deliverable from the project outlining Arcadis' preliminary recommendations.

Outfall Inventory and Mapping

During Permit Year 6, all of the City's known outfalls were mapped, photographed, and inspected during dry weather. If dry-weather flow was present, samples were collected and analyzed for coliform bacteria, MBAS, and Nitrogen. All outfalls were also sampled during a wet-weather event and samples were analyzed for Total coliform, E-Coli, MBAS, and Nitrogen. Sample results from five out of forty outfalls were identified as having elevated levels of bacteria. Follow-up sampling on those five discharges was performed and the associated drain system investigated for the possibility of illicit connections.

In addition, over the past several years the City has been aggressively tackling its obligations under a Consent Decree from the United States Environmental Protection Agency (US EPA) related to its wastewater system. One requirement of the Consent Decree is mapping of the wastewater collection system for hydraulic modeling and asset management purposes. To meet this requirement, the Department of Public Works, Wastewater Division (DPW Wastewater) has hired a GIS engineer and purchased a Leica GPS unit for field data collection. Concurrent with mapping the wastewater system, DPW Wastewater's GIS engineer has also begun mapping the City's MS4 infrastructure. He estimates that approximately 95% of the field data collection is complete. During the next permit year, DPW Engineering plans to finish the remainder of the data collection, and then begin performing QA/QC on the GPS data to build a complete and accurate GIS inventory of the City's MS4 infrastructure.

Illicit Discharge Detection and Elimination (IDDE)

IDDE continues to be an important part of the City's ongoing efforts to manage its wastewater and MS4 infrastructure. As reported in previous years, the City has established a dedicated crew of three to six individuals that are assigned to DPW Wastewater. These individuals, as part of their duties, perform daily inspections of both the wastewater and MS4 systems using City-owned CCTV equipment. Any illicit connections are identified during these inspections. In addition, the City has added two Professional Engineers to the DPW staff over the last five years. These two staff members devote part of their time to stormwater issues and will continue to be an important part of the City's efforts to administer its IDDE program. The City will reevaluate its IDDE program during Year 1 of the new MS4 permit as required per Section 2.3.4.

During the permit term, IDDE efforts have resulted in the detection of 23 illicit connections to the stormwater system. Two of these connections (31 Townsend Street and 245 Summer Street) were removed during Permit Year 12, one (359 Summer Street) was removed during Permit Year 13, and one (Gloria Ave.) was removed during Permit Year 14. In total, 18 known illicit connections have been removed during the permit term. During Permit Year 15, one illicit connection was identified at 45 Shattuck Street, and removal is planned for this year.

Four known illicit connections have not been corrected: 37 Fairbanks Street, 16 York Avenue, Merriam Parkway Extension (part of 032), and 181 Upham Street. Although the City's Wastewater Division plans to remove these connections, they consist of private wastewater infrastructure over which the City has no jurisdiction. As mentioned previously, the City has contracted Arcadis to assist with updating its stormwater ordinance, including the ability to enforce removal of illicit connections. Merriam Parkway Extension will most likely be targeted first, as this discharge receives flows from approximately four dwellings.

Combined Sewer Separation

As mentioned previously, the City has been aggressively tackling its obligations under the Consent Decree from the US EPA regarding its wastewater system. Many of these actions have a direct impact on stormwater quality. In Permit Year 12, the City completed several combined sewer separation projects, including separation of seven combination drain/sewer manholes and approximately 20,000 linear feet of combined sewer, installation of approximately 200 new deep sump catch basins, cleaning of sediment from 2,400 linear feet of large diameter drainage outfall pipe, and lining of over 5,200 linear feet of sewer main. These projects significantly reduce the potential for combined sewer overflows (CSO's) to the City's receiving waters and help improve water quality in receiving water bodies by removing a significant source of sediment.

During Permit Year 13, the City repaired three leaking sewer manholes located in the Nashua River and closed two CSO's along the Nashua River. These projects significantly reduce the potential for wastewater to overflow into the Nashua River. The City also completed a bank stabilization project along Falulah Brook to restore an approximately 300-foot length of eroded stream bank and prevent future erosion. This project was undertaken to fulfill the Supplemental Environmental Project requirement under the City's Consent Decree.

During Permit Year 14, construction began on the Beech and Hazel Streets Combined Sewer Separation Project, which included the separation of approximately 4,500 linear feet of combined sewer, conversion of one CSO to storm drain only, the installation of approximately 40 new deep sump catch basins, and lining of approximately 600 feet of sewer main. During Permit Year 14 the City also separated 16 combination drain/sewer manholes.

During Permit Year 15, the City completed construction on the Beech and Hazel Streets Combined Sewer Separation Project. In addition, the City separated 21 combination drain/sewer manholes.

To date, more than 50 combination drain/sewer manholes have been separated, with just over 200 remaining. The City's goal is to remove at least 20 combination drain/sewer manholes per year until they are all eliminated. Over the next year, the City also plans to close at least one CSO.

Community Partnerships

The City of Fitchburg looks for opportunities to embrace organizations within the community that share its goals of preserving the City's natural resources and minimizing stormwater pollution. The City has partnered with several organizations to complete projects that promote clean water and help the City meet the requirements of its MS4 permit. DPW Civil Engineer Nicholas Erickson presented on this topic at both the 2017 Maine Stormwater Conference and the 2018 New England Water and Environment Association (NEWEA) Annual Conference. The following sections describe these partnerships and some

of the resulting projects.

Montachusett Opportunity Council (MOC)

In Permit Year 12, the City entered into a partnership with the Montachusett Opportunity Council (MOC). This partnership stemmed from MOC receiving a Clearwater Revival Grant from the US EPA. The grant addressed stormwater and green infrastructure issues within the City. The kick-off for the grant was in September 2014, with all of the involved parties attending: Nashua River Watershed Association (NRWA), Massachusetts Watershed Coalition (MWC), and the Fitchburg DPW, Conservation/Planning, and Board of Health. Goals of the grant included the following:

- Provide informational sessions, trainings, and other resources to key stakeholders in the City regarding green stormwater practices
- Review the City's policies and procedures regarding green stormwater infrastructure and identify ways to better incorporate into ordinances
- Create an outdoor green stormwater infrastructure museum to showcase design strategies
- Conduct public outreach campaigns to raise awareness of stormwater issues and ways green stormwater infrastructure can be used to prevent pollution

In Permit Year 13, the City actively participated in helping MOC accomplish several of the grant's goals, including starting the development of a City ordinance based on MOC's recommendations for green stormwater infrastructure policies, incorporation of the green stormwater infrastructure museum into a redevelopment project for the First & Railroad Street Park, and performing the design of a raingarden for a workshop at Montachusett Regional Vocational Technical School.

In Permit Year 14, The City completed construction at First & Railroad Street Park, including the green stormwater infrastructure museum. In addition, the City worked with MOC and the Montachusett Regional Vocational Technical School to conduct the raingarden workshop. DPW workers from the City, along with students and teachers from the Montachusett Regional Vocational Technical School, worked together to build the raingarden designed during Permit Year 13 to treat stormwater runoff from a paved parking area at the school.

Supporting documentation for the Clearwater Revival Grant is attached to this year's annual report and includes the following:

- **Attachment 2:** A narrative and schedule prepared by MOC for the Clearwater Revival Grant Proposal
- **Attachment 3:** A report prepared by MOC that reviews the City's green stormwater infrastructure policies and procedures and recommends ways to improve ordinances
- **Attachment 4:** As built drawings for the First & Railroad Street Park redevelopment project, which includes an outdoor green infrastructure museum
- **Attachment 5:** A basis of design report prepared by the City for a rain garden for MOC's rain garden workshop

Nashua River Watershed Association

The City also continued its partnership with the Nashua River Watershed Association (NRWA) during Permit Year 15. The NRWA performs monthly sampling of the Nashua River just downstream from the City's East Wastewater Treatment Facility (WWTF) from April through October and tests for E. coli, dissolved oxygen, temperature, and conductivity. This information assists the City with monitoring its treated effluent from the WWTF.

The NWRA also works closely with MOC. During Permit Year 13, the NRWA assisted with several tasks for MOC's Clearwater Revival Grant. These tasks included preparation of the report summarizing the review of the City's green stormwater infrastructure policies as described above and stenciling storm

drains in the Elm Street area with youth to raise public awareness of stormwater pollution.

During Permit Year 14, the NRWA and MOC conducted another round of stenciling storm drains. The City supplied paint for both stenciling efforts. During the next year, the City plans to explore additional ways to utilize the services offered by the NRWA, including IDDE and water quality sampling assistance, public education, and public involvement.

Fitchburg Greenway Committee

The City is an integral member of the Fitchburg Greenway Committee (FGC), whose goal is to advocate for the protection, preservation, restoration, and responsible use Fitchburg's water resources, and riverfront land. During Permit Year 15, the City and FGC began discussing potential sources of funding (grants, etc.) for the removal of McTaggart's Pond Dam and restoration to pre-development conditions. Although not related directly to the City's MS4 system, this project will provide an ecological benefit nonetheless.

Central Massachusetts Regional Stormwater Coalition

During Permit Year 15, the City of Fitchburg joined the Central Massachusetts Regional Stormwater Coalition (CMRSWC). The CMRSWC is an invaluable resource for MS4 compliance for all of its 30+ member communities, and the City has actively participated in various events, meetings, and trainings since joining last summer. Please see **Attachment 6** for a summary of CMRSWC activities during Permit Year 15.

Local Colleges and Universities

During Permit Year 15, the City partnered with Worcester Polytechnic Institute's (WPI) Massachusetts Water Resource Outreach Center (WROC) to sponsor a project relating to stormwater. The project, undertaken by a group of four students from WPI, was called "Stormwater Runoff Education & Environmental Stewardship" and consisted of the development of a Science, Technology, Engineering, and Math (STEM) curriculum for Grade 5 Fitchburg Public School students designed to promote education on stormwater runoff, its impacts on the City's natural resources, and ways to mitigate stormwater runoff using green infrastructure. The abstract prepared by the students for their project states:

"In collaboration with the Fitchburg Department of Public Works and Fitchburg Public Schools, we developed an environmental education program consisting of a Student Workbook and complementary Educator Resource Guide. First and foremost, these materials improved the City of Fitchburg's compliance with the MS4 Permit's first minimum control measure, Public Education and Outreach. Additionally, these materials increased the ease with which diverse, inner city school systems can comply with Science, Technology, and Engineering Frame-works. Together the Student Workbook and Educator Guide combine interdisciplinary learning and hands-on, outdoor activities to instill environmental stewardship among Fitchburg's younger generations."

Please refer to **Attachment 7** for a copy of an educational brochure produced by the WPI project team as an interim deliverable. This brochure was designed to provide some basic information about what stormwater is, why people should care about it, and what people can do to keep stormwater clean. The brochure is intended to be distributed to student to take home and give to their parents.

Over the course of the next year, the City plans to hire a full-time summer intern from a local college or university to assist with various MS4-related tasks, including mapping, water quality sampling, and various other data collection efforts. This intern will be essential to helping the City meet the requirements of the new permit, as current staffing and budget issues significantly limit the amount of man-hours that can be dedicated to the City's MS4 program.

Part III. Summary of Minimum Control Measures

Public Education and Outreach

BMP ID #	BMP Description	Responsible Department / Person	Measurable Goal	Progress on Goal Permit Years 1 - 15	Planned Activities Year 1 of New MS4 Permit
PE-1	Partnership Program	DPW	Establish education and outreach program	For progress on PE-1 during Permit Years 1-14, please see previous Annual Report. In Permit Year 15, the City joined the CMRSWC and partnered with WPI WROC and four WPI students to develop Grade 5 STEM curriculum focusing on stormwater and green infrastructure for use in Fitchburg Public Schools.	Continue to foster relationships with MOC, NRWA, FGC, CMRSWC, WPI WROC, and local colleges/universities. Partnership program to be evaluated as part of overall education and outreach program update required per Section 2.3.2 of the new MS4 permit.
PE-2	Web Site Creation	DPW / IT	Website for storm water pollution prevention	City website updated in Permit Year 12 to include additional information/summary, provided links to EPA's stormwater website and watershed groups.	Website materials to be updated this year with new education and outreach content from DEP, EPA, and CMRSWC. Website content to be evaluated as part of overall education and outreach program update required per Section 2.3.2 of the new MS4 permit.
PE-3	Brochures and fact sheet	DPW	Door hangers distributed	New storm water mailer distributed via water and sewer bills in Permit Year 11. In Permit Year 15, the City worked with the WPI WROC and four WPI students to develop Grade 5 STEM curriculum focusing on stormwater and green infrastructure. One of the interim deliverables was a stormwater brochure to educate students and their parents.	Review existing material and update as necessary to include information required under Section 2.3.2 of the new MS4 permit and distribute to the required audiences at the required frequencies.

Part III. Summary of Minimum Control Measures

Public Education and Outreach

BMP ID #	BMP Description	Responsible Department / Person	Measurable Goal	Progress on Goal Permit Years 1 - 15	Planned Activities Year 1 of New MS4 Permit
PE-4	Classroom Education	DPW / School Dept.	50% of K-12 every 2 yrs.	Storm water education introduced as part of science curriculum grades 4 and 6. In Permit Year 15, the City worked with the WPI WROC and four WPI students to develop Grade 5 STEM curriculum focusing on stormwater and green infrastructure.	Continue development of STEM curriculum for other Grades. Classroom education to be evaluated as part of overall plan update required per section 2.3.2 of the new MS4 permit.

Part III. Summary of Minimum Control Measures

Public Involvement and Participation

BMP ID #	BMP Description	Responsible Department / Person	Measurable Goal	Progress on Goal Permit Years 1 - 15	Planned Activities Year 1 of New MS4 Permit
PP-1	Watershed Organization	DPW Water	Organize Watershed Committee	For progress on PP-1 during Permit Years 1-14, please see previous Annual Report. In Permit Year 15, Fitchburg continued to work closely with the North County Land Trust, NRWA, and FGC to pursue opportunities for land conservation, stream restoration, and other ecologically and environmentally friendly projects within the City's sensitive and critical watershed and buffer areas.	Continue to pursue grant opportunities to protect additional watershed land and open space areas through conservation restrictions and purchase of private land in sensitive and critical watershed and buffer areas. Continue partnership with North County Land Trust, NRWA, FGC, and other like-minded organizations during year 1 of the new MS4 permit per public involvement and participation requirements of Section 2.3.3.
PP-2	Stream cleanings	DPW	Civic Clean up days	Community service work crews from Dept. of Corrections regularly perform stream side clean up. Civic clean up days held each spring in all City wards. Stream clean up part of program.	Continue utilizing community service work crews from Dept. of Corrections for stream cleanings and continue to hold annual civic clean up days for stream cleaning during year 1 of the new MS4 permit per public involvement and participation requirements of Section 2.3.3.
PP-3	Storm drain stenciling	DPW / School Dept.	Civilian stenciling program	Stormwater stenciling by NRWA took place in the Cleghorn neighborhood during initial permit term. Locations of stormwater stenciling and installation of "don't dump" markers researched and discussed with Clearwater Revival Grant group. Additional stenciling completed as part of Clearwater Revival Grant in Permit Year 14. In Permit Year 15, discussions began between DPW and the School Dept. to incorporate stenciling activity into curriculum.	Continue to work with School Dept. to incorporate stenciling into curriculum. Storm drain stenciling will be evaluated as part of overall public involvement and participation program update required per Section 2.3.3 of the new MS4 permit.

Part III. Summary of Minimum Control Measures

Illicit Discharge Detection and Elimination

BMP ID #	BMP Description	Responsible Department / Person	Measurable Goal	Progress on Goal Permit Years 1 - 15	Planned Activities Year 1 of New MS4 Permit
ID-1	Storm Drain Map	DPW	Update Storm drain map	<p>All known storm drains inspected for dry flow, sampled as necessary. All outfalls and CSO's inspected and sampled during rain event. Mapping and digital photos completed. Resample and follow-up on target outfalls. 3 person collection crew and Civil Engineer tasked to allocate some time to storm water activities. Additional PE added to staff for collections system supervision. Will devote time to stormwater mapping and IDDE. In Permit Year 15, DPW Wastewater continued to GPS drainage infrastructure during sewer mapping work to supplement existing system map, approximately 95% complete.</p>	<p>Continue to review existing mapping for accuracy and update as necessary. GIS Engineer to continue to supplement existing map with additional data as collected. If necessary, develop scope of work for consultant to fill in gaps to meet requirements of Section 2.3.4.5 of the new MS4 permit.</p>
ID-2	Non-storm water discharge ordinance	Planning	Non-storm water ordinance	<p>Ordinance in place. In Permit Year 15, the City contracted Arcadis to perform a review of the City's stormwater ordinances and provide recommendations for revision to comply with 2003 and 2016 MS4 permit requirements. The project is ongoing.</p>	<p>Finish project with Arcadis and work with the Mayor, City Solicitor, and City Council on formal adoption.</p>
ID-3	Industrial/Business Connections	DPW	Establish monitoring program	<p>Continued survey of industrial and commercial connections as part of combined sewer separation projects and regular system inspections.</p>	<p>Review monitoring program and incorporate into overall IDDE program update required per section 2.3.4 of the new MS4 permit.</p>

Part III. Summary of Minimum Control Measures

Illicit Discharge Detection and Elimination

BMP ID #	BMP Description	Responsible Department / Person	Measurable Goal	Progress on Goal Permit Years 1 - 15	Planned Activities Year 1 of New MS4 Permit
ID-4	Illicit discharge elimination	BOH / DPW Wastewater	Establish Program	IDDE program established. 23 illicit connections identified to date, 18 removed. In Permit Year 15, one illicit connection identified. In addition, combined sewer separation work continued with completion of Beech and Hazel Streets Sewer Separation Project and separation of 21 combination drain/sewer manholes.	Continue working to remove illicit connections where possible (5 outstanding). Current IDDE program to be evaluated as part of overall IDDE plan update required per section 2.3.4 of the new MS4 permit.
ID-5	Illegal dumping task force	BOH / DPW / Public-Private Partnership	Form Task Force Quarterly Meetings	City established environmental task force and Fitchburg Greenway Committee, a public and private partnership. Group activities include streamside clean-up, community policing of environmental issues, outreach to schools and volunteer participation. City and NRWA worked on education of public on illicit discharges. Board of Health provides enforcement if illegal dumping is identified.	Illegal dumping to be addressed as part of overall IDDE plan update required per section 2.3.4 of the new MS4 permit.

Part III. Summary of Minimum Control Measures

Construction Site Runoff Control

BMP ID #	BMP Description	Responsible Department / Person	Measurable Goal	Progress on Goal Permit Years 1 - 15	Planned Activities Year 1 of New MS4 Permit
RC-1	Site Plan Review	Planning	Establish standards	Revised standards requiring BMPs for construction sites in accordance with MA Stormwater Standards. Implemented and applied to all new construction regulated under Planning Board. NRWA completed report under the MOC Clearwater Revival Grant recommending ordinance changes to incorporate green stormwater infrastructure. In Permit Year 15, the City contracted Arcadis to perform a review of the City's stormwater ordinances and provide recommendations for revision to comply with 2003 and 2016 MS4 permit requirements. The project is ongoing.	Finish project with Arcadis to finalize any needed updates to the associated ordinances and work with the Mayor, City Solicitor, and City Council on formal adoption.
RC-2	Erosion/Sediment control ordinance	Planning	Develop Ordinance	Existing ordinance updated. In Permit Year 15, the current ordinance was reviewed by Arcadis to verify compliance with the 2003 and 2016 MS4 permit requirements.	Finish project with Arcadis to finalize any needed updates to the ordinance and work with the Mayor, City Solicitor, and City Council on formal adoption.
RC-3	Storm Water Pollution Prevention Plan	DPW / Planning	Require Plan for all projects	Plan required for all subdivision projects and major construction projects. In Permit Year 15, current SWPPP requirements were reviewed by Arcadis to verify compliance with the 2003 and 2016 MS4 permit requirements.	Finish project with Arcadis to finalize any needed updates to the associated ordinance(s) and work with the Mayor, City Solicitor, and City Council on formal adoption.

Part III. Summary of Minimum Control Measures

Construction Site Runoff Control

BMP ID #	BMP Description	Responsible Department / Person	Measurable Goal	Progress on Goal Permit Years 1 - 15	Planned Activities Year 1 of New MS4 Permit
RC-4	BMP measures for sediment/erosion	Con-Com / Planning	Establish for construction sites	Con-Com reviews and inspects sites for compliance with approved plans and BMPs, Planning Board reviews for compliance with ordinances. In Permit Year 15, current requirements were reviewed by Arcadis to certify compliance with the 2003 and 2016 MS4 permit requirements.	Finish project with Arcadis to finalize any needed updates to the associated ordinance(s) and work with the Mayor, City Solicitor, and City Council on formal adoption.

Part III. Summary of Minimum Control Measures

Post Construction Runoff Control

BMP ID #	BMP Description	Responsible Department / Person	Measurable Goal	Progress on Goal Permit Years 1 - 15	Planned Activities Year 1 of New MS4 Permit
PC-1	Post construction runoff ordinance	Planning	Develop Ordinance	Existing stormwater ordinance requires developments to meet current MA Stormwater Standards. Drafted revised stormwater ordinance to meet requirements of 2015 draft permit. NRWA completed report recommending changes to ordinance under MOC Clearwater Revival Grant to incorporate green infrastructure. In Permit Year 15, current ordinance was reviewed by Arcadis to certify compliance with the 2003 and 2016 MS4 permit requirements.	Finish project with Arcadis to finalize any needed updates to the associated ordinance(s) and work with the Mayor, City Solicitor, and City Council on formal adoption.
PC-2	Site plan review for post construction	Planning	Adopt Standards	Post construction site plan review conducted for all planned sub-divisions and major construction sites. In Permit Year 15, current requirements were reviewed by Arcadis to verify compliance with the 2003 and 2016 MS4 permit requirements.	Finish project with Arcadis to finalize any needed updates to the associated ordinance(s) and work with the Mayor, City Solicitor, and City Council on formal adoption.

Part III. Summary of Minimum Control Measures

Post Construction Runoff Control

BMP ID #	BMP Description	Responsible Department / Person	Measurable Goal	Progress on Goal Permit Years 1 - 15	Planned Activities Year 1 of New MS4 Permit
PC-3	Operation and maintenance agreement	DPW	Develop Model	Models/Templates between communities and private BMP owners reviewed for applicability in City. Created spreadsheet linking existing privately owned BMPs to O&M plans approved during the permitting process. In Permit Year 15, City contracted Arcadis to make suggestions for incorporation into the City's stormwater ordinances for compliance with the 2003 and 2016 MS4 permit requirements.	Finish project with Arcadis to finalize any needed updates to the associated ordinance(s) and work with the Mayor, City Solicitor, and City Council on formal adoption.

Part III. Summary of Minimum Control Measures

Municipal Good Housekeeping

BMP ID #	BMP Description	Responsible Department / Person	Measurable Goal	Progress on Goal Permit Years 1 - 15	Planned Activities Year 1 of New MS4 Permit
MH-1	Pet waste collection	BOH	Distribute brochures	Educational material distributed in water and sewer bills year 11. In Permit Year 15, the City worked with the WPI WROC and four WPI students to develop Grade 5 STEM curriculum focusing on stormwater and green infrastructure. One of the interim deliverables was a stormwater brochure to educate students and their parents, and it includes information on pet waste collection.	Importance of proper disposal of pet waste to be included in revised public education program as required per Section 2.3.2 of the new MS4 permit.
MH-2	Parking lot and street cleaning	DPW	Increase frequency	Street and parking lots sweeping program active nine months per year. All streets swept a minimum of once per year. Main lines swept multiple times per year. Purchased new street sweeper in Permit Year 11. Additional sweeping of select streets performed as necessary. Purchased another new street sweeper in Permit Year 13. In Permit Year 15, street sweeping frequency increased to a minimum of twice per year.	Parking lot and street cleaning program to be evaluated and updated as required for compliance with Section 2.3.7 of the new MS4 permit.

Part III. Summary of Minimum Control Measures

Municipal Good Housekeeping

BMP ID #	BMP Description	Responsible Department / Person	Measurable Goal	Progress on Goal Permit Years 1 - 15	Planned Activities Year 1 of New MS4 Permit
MH-3	Catch basin cleaning	DPW	Implement program to track and increase frequency	Catch basin cleaning program active nine months per year. Second catch basin cleaner added to program in Permit Year 11. Additional man hours allocated to program with goal of cleaning all catch basins a minimum of once per year. Purchased another new catch basin cleaner in Permit Year 13. In Permit Year 15, the City initiated the purchase of a new Vactor truck to assist with catch basin cleaning efforts.	Finalize Vactor purchase with City Auditor's office. Catch basin cleaning program to be evaluated and updated as required for compliance with Section 2.3.7 of the new MS4 permit.
MH-4	Spill Response & Prevention	Fire Dept.	Formalize program provide education	The Fire Department conducts annual reviews and trainings at specific sites including wastewater, water and DPW facilities. Purchased new training videos in Permit Year 10 for this purpose.	Current spill response and prevention protocols to be evaluated and updated as required for compliance with Section 2.3.7 of the new MS4 permit.

Part III. Summary of Minimum Control Measures

BMP's for Meeting TMDL

BMP ID #	BMP Description	Responsible Department / Person	Measurable Goal	Progress on Goal Permit Years 1 - 15	Planned Activities Year 1 of New MS4 Permit
TM-1	Parking lot and street cleaning	DPW	Formalize Program	See municipal house keeping (MH-2)	Parking lot and street cleaning program to be evaluated and updated as required for compliance with Section 2.3.7 of the new MS4 permit.
TM-2	Catch Basin cleaning	DPW	Formalize Program	See municipal house keeping (MH-3)	Catch basin cleaning program to be evaluated and updated as required for compliance with Section 2.3.7 of the new MS4 permit.
TM-3	Install deep sumps	DPW / Planning	Require all new development to install	Deep sumps installed in all new and rebuilt catch basins. Approximately 200 new deep sump catch basins installed as part of CSS-4D sewer separation project and 2,400 feet of drainage piping cleaned of sediment in Permit Years 11-12. In Permit Year 15, 40 new deep sump catch basins installed as part of the Beech and Hazel Streets Combined Sewer Separation Project. In addition, the City contracted Arcadis to review requirements for new development and redevelopment, verify compliance with 2003 and 2016 MS4 permits, and provide recommendations for improvement.	Finish project with Arcadis to finalize any needed updates to the associated ordinance(s) and work with the Mayor, City Solicitor, and City Council on formal adoption.

Part III. Summary of Minimum Control Measures

BMP's for Meeting TMDL

BMP ID #	BMP Description	Responsible Department / Person	Measurable Goal	Progress on Goal Permit Years 1 - 15	Planned Activities Year 1 of New MS4 Permit
TM-4	Install gas and oil separators	DPW	Establish requirement	All new garages and other potential oil-using activities required to install oil water separation devices. In Permit Year 15, the City contracted Arcadis to review requirements for new development and redevelopment, verify compliance with 2003 and 2016 MS4 permits, and provide recommendations for improvement.	Finish project with Arcadis to finalize any needed updates to the associated ordinance(s) and work with the Mayor, City Solicitor, and City Council on formal adoption.
TM-5	Detention Basins	DPW / Planning	Establish design and requirement standards	Design standards established. Currently enforce standards for new construction. Spreadsheet developed linking existing privately owned BMPs to O&M plans approved during permitting process. In Permit Year 15, the City contracted Arcadis to review requirements for new development and redevelopment, verify compliance with 2003 and 2016 MS4 permits, and provide recommendations for improvement.	Finish project with Arcadis to finalize any needed updates to the associated ordinance(s) and work with the Mayor, City Solicitor, and City Council on formal adoption.

Attachment 1

MEMO

To: Nicholas J. Erickson, P.E.
Civil Engineer

Copies: Jeffrey A. Murawski, P.E.
Lenny Laakso, P.E.
Jennifer K. Lachmayr, P.E., BCEE

Arcadis U.S., Inc.
500 Edgewater Drive
Suite 511
Wakefield
Massachusetts 01880
Tel 781 224 4488

From: Kathryn Edwards, P.E.

Date: April 3, 2018

Arcadis Project No.: 00348003.0000

Subject: Recommendations for Stormwater Ordinance Updates and Stormwater Rules and Regulations Development

BACKGROUND

Arcadis has been contracted to provide professional services for a comprehensive review and update of the City of Fitchburg's (City's) stormwater and wastewater ordinances and regulations in accordance with the September 22, 2017 Scope of Work for the above referenced project. Arcadis will review and revise the City's current stormwater regulatory documents to ensure compliance with the 2003 EPA General Permit for Stormwater Discharges from the Small Municipal Separate Storm Sewer Systems (MS4) and the 2016 EPA and MassDEP MS4 permits, and organize its stormwater regulations into a single, cohesive document titled "Stormwater Rules and Regulations", with references made as appropriate in the City Code and various other City rules and regulations.

This technical memorandum shall address Task 1.3 as included in the City's scope of work and provided for reference below:

- 1.3 *The Consultant shall prepare a recommendations memo for review by the City that summarizes the following:*
- 1.3.1 *Content in Chapter 154 of the City Code, and stormwater-related content elsewhere in the City Code, that that should remain;*
 - 1.3.2 *Content that should be referenced in Chapter 154 of the City Code, or elsewhere in the City Code as necessary, but moved to a separate "Stormwater Rules and Regulations" document;*
 - 1.3.3 *Additional content for City Code chapters and the "Stormwater Rules and Regulations" document required to ensure compliance with the 2003 EPA MS4 permit and the 2016 EPA and MassDEP MS4 permits;*

- 1.3.4 *Revisions to various City rules and regulations necessary to reflect the revised structure of the City's stormwater regulations, including but not limited to those listed in 1.1.3 - 1.1.5*

RECOMMENDATIONS FOR ORDINANCE LANGUAGE

In our experience, a streamlined ordinance with accompanying Rules and Regulations provides flexibility for municipalities as planning priorities and the development landscape within the City change. To that end, it is our general recommendation that the Ordinance contain the basic legal authority language and definitions while the Rules and Regulations should contain technical requirements, design standards, fees, and procedural language. Preferred guidance documents and additional references may be pointed to from the Rules and Regulations.

Recommended Ordinance Outline

The following is a recommended outline of City Code Chapter 154 – Stormwater Management and Erosion Control (Ordinance).

Headings and text shown in **orange** are recommended additions and/or changes to the outline structure.

We recommend that headings and text which are struck through be removed from the Ordinance and placed into the accompanying Stormwater Management Rules and Regulations (Rules and Regulations) document.

Additionally, we recommend that Article headings I through III are included within this Ordinance to demarcate sections that fall within distinct categories; these headings are shown **bolded and in orange**.

Article I: General Provisions

154-1 Purpose

154-2 Definitions

154-3 Applicability

154-4 Administration

154-5 Regulations

~~*154-4 Application requirements*~~

~~*154-5 Design standards*~~

~~*154-6 Responsibility for installation and construction*~~

~~*154-7 Plan approval and review*~~

~~*154-8 Maintenance and inspection*~~

~~*154-9 154-6 Enforcement*~~

154-7 Severability

Article II: Non-Stormwater Discharges, Connections and Obstructions

154-8 Prohibited activities

154-9 Allowable discharges (exemptions)

154-10 Emergency suspension of municipal storm drainage access

154-11 Notification of spills

Article III: Construction and Post Construction Stormwater Management of New Developments and Redevelopments

154-12 Permit required

154-13 Permits and procedures

154-14 Fee structure

154-15 Waivers

A redline/strikeout version of the original Ordinance outline with recommended changes is included in Attachment A and a markup of the existing Ordinance indicating language to be moved to the Rules and Regulations is included in Attachment B.

Language to be Added to Comply with EPA MS4 Permit

One of the main objectives of this task is to revise the regulatory documents to achieve compliance with the 2003 and 2016 MA MS4 Permits. Within both permits, there are EPA-required ordinances/regulatory mechanisms to be enacted and enforced by the City. These requirements are summarized below and can be found in the 2016 Massachusetts General Permit. The section location where each requirement will be addressed is noted in parentheses.

1. Definitions (*154-2*): Edits will be made to bring definitions up to date with the MS4 permit requirements.
2. Applicability (*154-3*): Arcadis will revise applicability paragraphs to comply with MS4 permit requirements. The MS4 permit requires municipalities to regulate discharges to the MS4 located within the Urbanized Area as defined by the EPA. Although parts of the City of Fitchburg are located outside of the defined Urbanized Area, it is recommended that discharges to any portion of Fitchburg's separate storm drainage system be regulated by the City within this ordinance.

Sample language to be included in the Ordinance:

Stormwater Drainage System and Waters of the Commonwealth of Massachusetts

- a. *This Ordinance shall apply to flows entering the City's Storm Drainage System and Waters of the Commonwealth of Massachusetts.*

Construction and Post-Construction Activities

- a. *This Ordinance shall apply to any construction activity, including clearing, grading, and excavation that will disturb equal to or greater than one acre of land or will disturb less than one acre of land but is part of a larger common plan of development or sale that will ultimately disturb equal to or greater than one acre of land draining to the City's storm drainage system. After the initial common plan construction activity is completed for a particular parcel, any subsequent development or redevelopment of that parcel would be regarded as a new plan of development. For example, after a house is built and occupied, any future construction on that lot (e.g., reconstructing after fire, adding a pool or parking area, etc.), would stand alone as a new common plan for purposes of calculating acreage disturbed to determine if a Stormwater Management Permit is required. Construction activity does not include routine maintenance that is performed to maintain the original line and grade, hydraulic capacity, or the original purpose of the site. *Note that permitting thresholds (1 acre) are to be discussed and determined with City stakeholders.*

3. Illicit Discharge Detection and Elimination (IDDE) program (154-8):

The MS4 permit drafted in 2016 and slated to become effective July 1, 2018 requires municipalities which are covered under the permit to enact regulatory mechanisms granting the legal authority to prohibit, investigate and eliminate illicit discharges, including illicit discharges originating on private property. This requirement also stipulates that the MS4 community should implement appropriate enforcement procedures and actions.

Sample language to be included in the Ordinance to satisfy this requirement:

No person shall dump, discharge, cause or allow to be discharged any pollutant or non-stormwater discharge into the municipal separate storm drainage system (MS4), into a watercourse, or into the waters of the Commonwealth of Massachusetts.

This section will provide the legal authority for the City to prohibit, investigate, and eliminate illegal discharges, including those originating on private property and will reference the Enforcement section regarding violations, penalties, and remedial actions.

Most communities also include a section on allowable discharges (exemptions) which may include: uncontaminated groundwater, waterline flushing, diverted stream flow, etc.

4. Construction site stormwater runoff control (154-12 and Rules and Regulations):

Additionally, the EPA requires small MS4 communities to enact an ordinance or regulatory mechanism that requires the use of sediment and erosion control practices at construction sites. In addition to addressing sediment and erosion control, the regulatory documents must include controls for other wastes on construction sites such as demolition debris, litter and sanitary wastes.

Sample language to be included in the Rules and Regulations to satisfy this requirement:

Construction and Waste Materials shall mean excess or discarded building or site materials, including but not limited to concrete truck washout, chemicals, litter and sanitary waste at a construction site that may adversely impact water quality.

Erosion and Sediment Control Plan

1. *An Erosion and Sediment Control Plan must meet the following objectives applicable to all land disturbance activities:*

- a.) *The objective of this Article is to minimize to the maximum extent practicable sediments or pollutants exiting the site, entering the public right-of-way or being deposited into any Water Resource or stormwater drainage system.*
- b) *In order to meet the objectives, set forth in Section 1 (a) above, the owner or applicant shall:*
 - i. *Implement measures intended to keep soil on site or out of Water Resources, stormwater drainage systems or the public right-of-way as the first step in any development.*
 - ii. *Remove any soil that enters the public right-of-way...*
 - x. *Properly manage on-site construction and waste materials.*

xi. ...

(Note: paragraphs iii-ix omitted intentionally. Full language to be included in the Rules and Regulations.)

5. 154-12 Stormwater management in new development and redevelopment (154-12 and Rules and Regulations):

The 2016 MA MS4 Permit regulations requirements for new development and redevelopment include several updates. MS4 cities are required to develop an ordinance or other regulatory mechanism within two years of the effective date of the permit to contain provisions that are at least as stringent as the following:

- A. Low Impact Development (LID) and Green Infrastructure (GI) site planning and design strategies must be used to the maximum extent feasible.
- B. All design of treatment and infiltration practices should follow the guidance of Volume 2 of the Massachusetts Stormwater Handbook, or equivalent State or Federally approved BMP design guidance.
- C. Stormwater management practices designed for property development and redevelopment shall be designed in accordance with the Massachusetts Stormwater Handbook Standards 1-9.
- D. All stormwater management systems built alongside a new development within the MS4 system shall be designed to:
 - 1. Retain the volume of runoff of at least one inch multiplied by the total post-construction impervious surface area on the site and/or
 - 2. remove 90% of the average annual load of Total Suspended Solids (TSS) generated from the total post-construction impervious area on the site, and
 - 3. remove 60% of the average annual load of Total Phosphorus (TP) generated from the total post-construction impervious surface area on the site.
- E. All stormwater management systems built alongside a redevelopment within the MS4 system shall be designed to:
 - 1. Retain the volume of runoff of at least 0.8 inches multiplied by the total post-construction impervious surface area on the site and/or
 - 2. remove 80% of the average annual load of Total Suspended Solids (TSS) generated from the total post-construction impervious area on the site, and
 - 3. remove 50% of the average annual load of Total Phosphorus (TP) generated from the total post-construction impervious surface area on the site.

The requirements within items A and B are recommended to be addressed by the addition of Article III to the Ordinance. Design standards, technical requirements and procedures within items C, D and E will be located within the Rules and Regulations.

Article II: Non-Stormwater Discharges, Connections and Obstructions

This Article and its subsequent sections will address the EPA requirement for an illicit discharge detection and elimination program.

Article III: Construction and Post Construction Stormwater Management of New Developments and Redevelopments

This Article and its subsequent sections will address the MS4 permit requirements for construction site stormwater runoff control and stormwater management in new development and redevelopment. The City's Design Standards and requirements for review of stormwater management systems are recommended to be included in the Stormwater Rules and Regulations.

The Stormwater Rules and Regulations will include construction standards and testing requirements for new developments and redevelopments.

Sections to be Added to City Code Chapter 154 (Ordinance)

154-4 Administration

This section is recommended to clearly state which department, role, or entity within the City will administer, implement and enforce the Ordinance and Rules and Regulations thereunder or, in other words, to name the Authorized Enforcement Agency. This section is also recommended to serve as a general authorization for this Authorized Enforcement Agency to delegate any powers granted or duties imposed within this Ordinance to either agents or employees of the Agency. Options for Authorized Enforcement Agency are discussed later in this memo.

154-5 Regulations

This section is recommended to grant the Authorized Enforcement Agency the latitude to adopt and amend rules and regulations to support the Ordinance.

Sample language:

The Authorized Enforcement Agency may adopt and periodically amend rules and regulations, not inconsistent, herewith, to effectuate the purposes of this Ordinance. Said regulations may include, but shall not be limited to provisions regarding: administration; application requirements and fees; permitting procedures and requirements; design standards; surety requirements; inspection and site supervision requirements; waivers and exemptions; and enforcement procedures. Failure by the Authorized Enforcement Agency to promulgate such rules and regulations shall not have the effect of suspending or invalidating this Ordinance.

154-7 Severability

This section is recommended to uphold the integrity and enforceability of this Ordinance should one or more sections be deemed invalid in any way.

RECOMMENDATIONS FOR CHANGES TO OTHER REGULATORY DOCUMENTS

To avoid conflicts with various City rules and regulations necessary to reflect the revised structure of this Ordinance (Chapter 154 of the City Code), we propose the following:

Zoning (Chapter 181): a section which points to the thresholds defined in Chapter 154 triggering appropriate applicants to file for a Stormwater Management and Erosion Control Permit under the new Ordinance.

Sewer (Chapter 147): additional definitions including, sanitary sewer, storm drain, MS4, private sewer, private storm drain, public sewer, and public storm drain.

Wetlands (Chapter 178): a section which points to the thresholds defined in Chapter 154 triggering appropriate applicants to file for a Stormwater Management and Erosion Control Permit under the new Ordinance. A statement reminding applicants that filings under Chapter 154 and 178 may be streamlined to cover both sets of requirements.

We recommend a meeting with the Key City Stakeholders to discuss the above recommendations and work to resolve any other conflicts caused by the changes proposed to Chapter 154. The objective of this meeting will be to build consensus for the stormwater permitting process and identify requirements/standards which may help streamline permitting submissions to be reviewed by two or more departments (City's preferred plan size, etc.).

NEXT STEPS

To move forward in the review and update of these regulatory documents, Arcadis will require input from the City and key City stakeholders regarding the following:

Authorized Enforcement Agency

The Authorized Enforcement Agency, determined by the City, will assume similar duties to those established in Section 154-6 (formerly 154-9) Enforcement. The duties of the Agency will include the administration and enforcement of the Stormwater Management and Erosion Control Ordinance in addition to the promulgation and amendment of Rules and Regulations relating to this Ordinance. This Agency will additionally have the latitude to delegate responsibilities and powers relating to this Ordinance. In previous discussions, the City has indicated interest in the establishment of a Stormwater Commission or Board. The Commission or Board would be a group of individuals who share in the responsibilities of the Agency.

It is recommended that even if a Board or Commission is established, that the City define a Stormwater Commissioner position within the Department of Public Works Engineering Division to serve as the Authorized Enforcement Agency head. This creates a consistent role responsible for stormwater compliance within the City.

Stormwater Permit Thresholds/ Project Review

The existing Ordinance (Chapter 154) requires developers and redevelopers within the MS4 to submit a stormwater management and erosion control plan to the City if one or all the following conditions will be met on the project:

- The total cumulative disturbed area exceeds 20,000 square feet.
- Disturbed areas 2,000 square feet or greater fall within the watershed of any of the City's drinking water supplies.
- Disturbed areas containing slope lengths exceeding 25 feet on slopes greater than 15%.

While the City's threshold is more stringent than the MA MS4 Permit, which requires all land disturbance greater than one acre of gross area be reviewed, 73 percent of tax parcels within the City fall below 20,000 square feet of gross area, significantly limiting the potential project proponents and Stormwater

MEMO

project reviews, thus limiting the City's control of stormwater discharges from new and redevelopment projects both during and after construction.

Other conditions for project review could include: percent of impervious area added, addition of a defined number of parking spaces, and triggers for vertical construction.

City feedback regarding these thresholds will be needed to draft the updated Ordinance.

ATTACHMENTS

Attachment A: Proposed Outline Structure of Ordinance (City Code Chapter 154)

Attachment B: Existing Ordinance Markup

Attachment 2

Clearwater Revival Grant Proposal Summary

Written by MOC and submitted to EPA in Grant Application

I. Project Title and Project Purpose Statement

As the designated non-profit Community Action Agency serving the socio-economically disadvantaged in North Central Massachusetts, the Montachusett Opportunity Council (MOC) proposes the *Clearwater Revival* Project to address stormwater (SW) pollution of the Nashua River and improve the health of vulnerable neighborhoods in Fitchburg, MA 01420.

Clearwater Revival has four goals:

- 1) Capacity-building of City stakeholders. The project will allow for training of the partnership to increase expertise about stormwater management (SWM) using green infrastructure (GI).
- 2) Policy, systems and best management review. We will assess the City's systems and policies to see how GI and other low impact development (LID) methods can be integrated into procedures and policies and what barriers may exist.
- 3) Creation of an outdoor "museum" on a vacant lot showcasing green infrastructure design strategies. A city owned vacant lot in a low-income neighborhood will be developed as a *Clearwater Revival* outdoor museum showcasing various GI and LID methods that residents can use on their own property.
- 4) Increasing awareness of residents and community organizations about SW issues through neighborhood walks and building resident knowledge about ways they can prevent water pollution. Water walk/workshops in two targeted low-income neighborhoods will serve multiple purposes: to learn from residents where SW is a problem, to use photos as a teaching tool to draw attention to aspects of the built environment that exacerbate the SW issue and to follow up the walk with a small workshop highlighting things residents can do to protect the water. MOC youth peer leaders will also be educated about SW issues and they will help create videos to educate the community about the problem and solutions.

Clearwater Revival will take place in Fitchburg, MA, and will focus on the Clean Water Act, Section 104(b) in order to move forward on the community's vision for a green and healthy local environment. The project will also integrate elements of the Solid Waste Disposal Act, Section 8001(a) and the Toxic Substances Control Act, Section 10(a) into programming since the disposal of waste, particularly pet waste, pharmaceuticals and toxic compounds into stormwater systems causes both environmental and public health problems.

This project builds on already existing collaborative efforts, particularly the work of the Healthy Zoning workgroup (HZW). Led by MOC, this workgroup has been meeting for the past year and includes key City stakeholders (i.e. the Planning and Housing Departments, Board of Health (BOH), and Department of Public Works) as well as the Massachusetts Regional Planning commission (MRPC), Twin Cities Community Development Corporation (Twin Cities CDC) and Growing Places, a non-profit engaging residents in community gardening. Currently, the HZW's focus is to address the vacant lot issue in Fitchburg and a key part of its strategy is to find ways to integrate green infrastructure (GI) for stormwater management (SWM) into its efforts to turn vacant lots from neighborhood problems to neighborhood assets.

Together with MOC (lead applicant), project partners on the MOAs are: 1) City of Fitchburg; 2) Massachusetts Watershed Coalition, 3) the Nashua River Watershed Association and 4) Twin Cities CDC.

II. Environmental and Public Health Information about the Affected Community

Local environmental and public health issues addressed by *Clearwater Revival* include: the pollution of the Nashua River due to SW runoff and discharges from Combined Sewer Overflows (CSO's) which pose a public health hazard through bacterial, viral and toxic chemical

loads dumped into the River. Bacteria, viruses and parasites that may be present in impaired water can cause various illnesses such as ear and eye discharges, skin rashes and gastrointestinal problems with skin contact or through ingestion. The pollution of the river also impacts aquatic life and the health of the River through nutrient loading, addition of oxygen-depleting substances and increase in water temperature. Drinking water of downstream communities and recreational use of the River is negatively impacted. The SW problem is particularly acute in older high density, low-income neighborhoods near the Nashua River. These neighborhoods make up 34.7% of Fitchburg's population and are the focus of *Clearwater Revival*.

The 2012 Waterbody Report for the two segments of the North Nashua River that flow through or near our targeted neighborhoods indicate that the overall status of this 8.6 mile section of the River is impaired (maps MA81-01 and MA81-02) with waters too polluted or degraded to meet state water quality standards. Primary recreational contact such as swimming and secondary recreational contact such as fishing or wading is not advised. Fish consumption has not been assessed for either segment but for MA81-02, assessment of wildlife, fish and aquatic life shows that it, too, is impaired. For both segments, one cause of impairment is *E. coli* with probable sources being CSO's and non-point sources during wet weather events, urban related runoff, illicit connections/hook-ups to storm sewers and other unknown causes.

In August 2012, Fitchburg was penalized by EPA and Department of Justice for violating the Clean Water Act due to repeated non-compliance with its discharge permit. The primary cause of the violations is the large volume of SW that flows into the wastewater treatment plant via the sanitary sewer system. The combination of SW and wastewater at the plant often exceeds its treatment capacity. When this occurs, some of the treatment process is bypassed, causing partially treated sewage to be discharged into the Nashua River. SW flow into the treatment plant must be reduced so that capacity of the plant is not exceeded. Combined sewer separation projects and plant modifications are underway to accomplish this, but GI can play an important role by keeping SW out of the system in the first place. Conversation with the Commissioner of Public Works in Fitchburg indicates that the problem of CSO's and urban runoff are exacerbated by Fitchburg's steep topography that causes erosion and ground water near the surface that seeps out onto pavement. The public's behavior is also problematic with catch basins in some neighborhoods filled with yard waste and even plastic bags of dog waste. Increasing Fitchburg's capacity to implement GI for SWM is needed. The 2010 draft MS4 General Permit for SW included provisions that would encourage the use of LID and GI. At this time, Fitchburg would not be compliance-ready for this requirement. Implementing GI has been a strategy suggested in a 2009 Report produced for the City by UMASS-Amherst Landscape Sustainability Studio: *Green Fitchburg: Opportunities, Strategies and Visions for the Future*. Rain gardens were specifically mentioned in several areas to mitigate SW problems along major roadways however no progress has been made in this area.

Affected Community Characteristics: Fitchburg is located in North Central Worcester County, approximately 10 miles south of New Hampshire and 50 miles west of Boston with a population of 40,318 (2010 Census). The Nashua River is the heart of the city. As the oldest city in this area, Fitchburg was once a thriving manufacturing center whose industries attracted immigrants who settled in dense, multi-family housing near factories located along the Nashua River. As the manufacturing base began to erode in the 1960s, Fitchburg's economic prosperity declined and its population demographics began to shift. Today, the population of Fitchburg is disproportionately low-income (19.4% persons below poverty level compared to 10.5% in the state) with more than twice the number of families with children under age 18 living below

poverty than in the state (23.8% Fitchburg/11.5% state). As of March 2013, Fitchburg's unemployment rate is 3.4 percentage points above the state rate (10.2% Fitchburg/6.8% state). 21.6% of Fitchburg residents self-identify as Hispanic or Latino which is more than 2X that of the state (9.6%) and 23.4% speak a language other than English in the home (2008-2012 American Community Survey estimate).

Many of the City's residents suffer disproportionately from chronic diseases and secondary conditions. According to a 2011 Community Health Assessment (CHA) report of North Central MA, Fitchburg evidences heightened rates of the following: Cancer: While cancer mortality rates in Fitchburg (185 per 100,000) are roughly comparable with the state (183), Black non-Hispanics suffer disproportionately in Fitchburg with a mortality rate of 629 per 100,000. Asthma: Asthma hospitalization rates at 190 per 100,000 are greater in Fitchburg than the state (142) with children under 5 years (356) and Hispanics (369) having the highest rates locally. Mortality: Premature mortality at 398.9 per 100,000 in Fitchburg is greater than the state (304.4). Both Hispanics (451) and Black, non-Hispanics (441) suffer disproportionately in Fitchburg. Mental Health: Fitchburg's suicide rate (8.1 per 100,000) is only slightly higher than the state's (7.0), but its self-inflicted injury rate (87.2 per 100,000) is almost double that of the state (44.3). Crime statistics show that Fitchburg's overall violent crime rate per 1,000 residents is dramatically higher (7.71) than the rest of MA (4.28).

A map of EJ regions in Central MA created by the MA Executive Office of Energy and Environmental Affairs shows that a significant proportion of Fitchburg's most vulnerable residents, those at greatest risk of being impacted by poverty, crime and health disparities, live along the Nashua River in what used to be the City's industrial corridor. This same area has been significantly impacted by the release of environmental toxins including a majority of reportable hazardous waste release events per MA DEPs Hazardous Waste Map for Fitchburg. Fitchburg's topography exacerbates the environmental problems experienced by vulnerable populations since the City is built on steep grades and this is particularly true of the residential areas adjoining the industrial corridor. Not only do many of these areas lie in flood zones, during rains the steep topography and large amount of impervious surfaces in these neighborhoods cause trash and other contaminants to flow into the sewer system and if overwhelmed, directly into the Nashua River.

Creating a healthy community is a key goal in Fitchburg. In addition to the water quality benefits from implementing GI, there are additional benefits to the affected community. Focus groups, walk audits and meetings with the affected community over several years has shown that: 1) there is a lack of high quality green space in targeted neighborhoods; 2) residents see vacant lots as neighborhood problems that foster crime and trash accumulation and inhibit safe walking; and 3) there is a lack of places to cool off in the summer. *Clearwater Revival* can help address some of these issues by creating one high quality green space in a vacant lot that can help mitigate the heat island effect and in the long term, making the North Nashua River a safe place for water recreation. An added long-term benefit to the affected community is cost-savings on sewer rates. Because of the cost of implementing grey infrastructure to remediate SW overflow into the Nashua River as well as reduce other pollutant levels, sewer bills in Fitchburg went up 68% in 2012, for an average household sewer bill of \$730. While many people in our affected community are renters, these costs are likely passed down to them from landlords. By increasing City capacity to implement GI, we can not only begin to realize the social and environmental benefits of GI, but also give the City and its residents the economic benefits as well.

III. Organization's Historical Connection to the Affected Community

History: Founded in 1966, MOC is the designated non-profit Community Action Agency serving the socio-economically disadvantaged in North Central MA. MOC's mission is to alleviate poverty and create healthy communities by providing services, coordinating community resources that promote self-sufficiency and advocating for social change. It serves families and individuals across the lifespan through its various divisions and delegate agencies, offering an array of programs including Childhood Lead Poisoning Prevention, Green and Healthy Homes, Housing and Weatherization, Women, Infants and Children (WIC) Nutrition Program and Child Care and Head Start (CCHS).

Work with Affected Community: MOC has established the capacity, linkages and credibility within North Central MA and in particular the targeted community of Fitchburg, to successfully implement *Clearwater Revival*. The Board of Directors is comprised of municipal officials, low-income representatives and community stakeholders committed to the agency's mission and the demographics of MOC staff mirror those of the community. The Executive Director has led the agency for 27 years. Ms. McDermott plays a strong leadership role in the community on health and social issues, including but not limited to founding and co-chairing the Joint Coalition on Health and helping to establish Community Health Connections, a local, federally qualified community health center. Every three years, MOC undertakes a Community Needs Assessment, an extensive process composed of stakeholder interviews, focus groups and hundreds of surveys. The quantitative and qualitative data collected from residents and community stakeholders informs **strategic goal setting** and program development. In addition to MOC's ability to lead, we are known for our vision and ability to create and innovate to address community needs. For example, MOC initiated a Green and Clean program with two years of funding from the Toxics Use Reduction Institute (TURI). The project has educated hundreds of individuals in hands-on workshops, worked with United Hmong of Massachusetts to translate materials and hold workshops for Hmong residents and with our WIC program and Elder Nutrition program, piloted safer chemical and non-chemical sanitizers and disinfectants. MOC also received funding to coordinate a Green and Healthy Homes **multi-stakeholder partnership** composed of City Departments and community-based organizations (CBOs) that worked together to create a common home assessment form and partner referral system enabling low-income residents to receive coordinated, efficient home repair with **leveraged funds**. This forward way of thinking puts MOC in a strategic position within the community that will enable us to successfully implement *Clearwater Revival*.

Residents in Decision-Making: Not only do low-income representatives from North Central MA sit on MOC's Board of Directors, **residents are part of advisory boards** for specific programs allowing for **constructive engagement in program development**. For example, parents are part of CCHS's Health Advisory group, local elders make up the Elder Nutrition Program's Advisory Board, and client's of our CARE AIDS/HIV Case Management program participate on the consumer advisory board. MOC's neighborhood mobilizer and teen peer educators play a key **leadership** role in providing outreach and education to the community for our anti-obesity efforts, teen pregnancy prevention and family planning work. They take part in partnership meetings and present data to key City stakeholders and evaluators to advocate for community awareness on issues. **Resident input is sought after to steer projects impacting their community**. For example, for a current project to design and implement a green space in a low-income housing development, residents were invited to a presentation by the Landscape

Architect so that their input could be incorporated into the design strategy. The HZW workgroup coordinated a **community scoping session** that was part of a Health Impact Assessment focusing on **strategies** to improve vacant lots in the City. Over 50 stakeholders attended to weigh options for turning vacant lots into community assets. Together with a focus group held with a community-based organization, these inputs pointed out the need for more green spaces within targeted communities.

Increase Community Capacity: MOC is recognized for its strong community ties and extensive networking system. We have developed long-lasting relationships with individuals and organizations within and beyond our service territory throughout our 48 year history. One example is the *Fun 'n FITchburg* initiative. Partnering with the City of Fitchburg and over 80 individuals including residents, city councilors, the Mayor, businesses, the local university and environmental groups, MOC is leading a youth obesity prevention campaign funded by the Robert Wood Johnson Foundation (RWJF) and the Massachusetts Department of Public Health. Now in its fifth year, the *Fun 'n FITchburg* Partnership has become a strong voice in advocating for systems, policy and environmental changes to make healthy eating and active living the easy choice for Fitchburg residents. Projects over the years have emerged through dialogue and **iterative community visioning exercises**. Together residents, neighborhood mobilizers and youth peer leaders have conducted park and walk audits resulting in a citizen Adopt-a-Park program, a healthy vending in parks resolution and enthusiasm among municipal officials to adopt a Complete Streets policy. The HZW workgroup formed due to concerns about vacant lots voiced by the Partnership during focus groups and walk audits conducted through the *Fun 'n FITchburg* initiative. The Partnership has also been working for over three years with the Fitchburg Housing Authority (FHA) and an array of partners to convert a large green space in the center of the low-income housing complex into an active living space that integrates natural play spaces into its design. This year, a wet area at the entrance to the field was converted to a bioretention area/butterfly garden that will be used as an environmental education site. Our collaboration with the City on the *Fun 'n FITchburg* initiative has **leveraged additional funding** to spearhead a regional Healthy Weight initiative by local Boards of Health and funding to amplify youth obesity prevention messages to area day cares and schools.

Maintaining Ongoing Relationships: MOC **collaborates** with area non-profits, residents and municipal officials to **leverage funding and expertise** to move projects forward. Our work with the FHA exemplifies this. Because of significant incidents that disrupted the neighborhood at one FHA site, the Executive Directors at MOC and the FHA called together a meeting with community leaders including the Mayor, Chief of Police, Superintendent of Schools and representatives from state agencies and community-based organizations. The result was a charge to all community groups to expand services and resources and find ways to support residents, instill a sense of pride in the neighborhood and make it safer. The MOC Homework Center evolved from this meeting and 42 children are now enrolled with 25 attending daily. *Fun 'n FITchburg's* green space initiative at the FHA (described above) is located on land behind the Homework Center site. To create a **community vision** for this space, we brought together residents and community leaders to help develop a 5 year plan of action to create a high quality active living space for the neighborhood. MOC continues to do a Needs Assessment of the communities we work in and **collaborates with partners and residents** on how to address ongoing and new issues. MOC holds leadership positions on local and regional boards such as the Community Health Center's Board of Directors and the Joint Coalition on Health. MOC also attends Community Health Network Area (CHNA) 9 meetings and local community meetings

including the City’s recycling and open space committees, Elm St. Neighborhood Association meetings and community meetings in the Green Acres neighborhood.

IV. Project Description

i.) Activities the project will undertake

The long-term environmental and public health results *Clearwater Revival* seeks to achieve are a decrease in SW pollution of the Nashua River and increase in resident health by reducing bacterial, viral and chemical loading into the River from runoff. An added short-term outcome of the project is creating one green space in a targeted low-income neighborhood. Green spaces offer multiple social and ecological benefits such as social gathering places, sense of place, environmental education opportunities, a reduction in urban heat island effect, increased biodiversity and decreased stress. It has also been shown that GI creates economic value in a community which would be advantageous to this economically depressed City. The green space we propose would also be an educational “museum” raising awareness of stormwater pollution and the ways residents can help prevent water pollution.

Clearwater Revival has four goals that will allow us to work toward the long-term environmental and public health results we hope to achieve. These goals focus on 1) capacity-building of City, 2) policy, systems and best management review to promote GI in Fitchburg, 3) creation of an outdoor “museum” on a vacant lot showcasing green infrastructure design strategies and 4) increasing residents’ and community-based organizations’ awareness about SW issues through neighborhood walks and, with the help of MOC youth peer leaders, building resident knowledge about ways they can prevent water pollution. Following is a description of how *Clearwater Revival* will achieve its overall aims to decrease SW pollution of the Nashua River and increase public health by reducing bacterial, viral and chemical loading into the River. Please see logic model attached also.

Goal 1: Capacity building of City stakeholders		
Activities	Milestones	Responsible Partner
<ul style="list-style-type: none"> - Introduce new project partners (NRWA and Massachusetts Watershed Coalition) to already-existing HZW group - Convene meetings - Develop QAPP - Identify training needs - Research potential speakers, invite them and promote the event - Research design strategies for small residential GI projects, where to source material locally and costs of elements - Design and print residential booklet - Research GI incentives for residents, businesses and developers - Discuss which incentives are needed and would work in Fitchburg 	<ul style="list-style-type: none"> - QAPP developed by Yr1 Q1 - 4 trainings held (2/yr) - all trainings completed by Yr2 Q4 - Speaker events held (1/yr) - by Q4 of each Yr one speaker event held - Resource booklet for small residential GI projects created by Yr2 Q4 - List of incentives for GI projects generated by Yr2 Q4 	<ul style="list-style-type: none"> - MOC - HZW
Goal 2: Policy, systems and best management review to promote GI in Fitchburg		
Activities	Milestones	Responsible Partner
<ul style="list-style-type: none"> - Collaborative discussions with City stakeholders and NRWA to focus 	<ul style="list-style-type: none"> - Policy/system report distributed to City 	<ul style="list-style-type: none"> - City stakeholders

policy/system review - Conduct review - Write report - Disseminate report to City departments	departments by Yr2Q4	- NWRA Smart Growth Circuit Rider
Goal 3: Creation of an “Outdoor GI Museum” on a vacant lot showcasing GI design strategies		
Activities	Milestones	Responsible Partner
- Create priority list of 10 vacant lots - Conduct field surveys of vacant lots - Design “Outdoor Museum” - Purchase supplies - Coordinate workers - Build the GI museum - Design signage - Install signs	- Field surveys conducted by Yr1 Q4 - GI Museum built by Yr2 Q 4 - Signs installed by Yr2 Q4	- MOC - Twin Cities CDC - City of Fitchburg - Massachusetts Watershed Coalition
Goal 4: Increase awareness of residents and community based organizations about SW issues and ways to prevent water pollution		
Activities	Milestones	Responsible Partner
A. Conduct 2 neighborhood walk/workshops B. Conduct 2 presentations for youth peer leaders Conduct 2 water quality trainings for youth peer leaders Conduct 1-2 storm drain stenciling workshops for youth peer leaders and neighborhood mobilizer C. Storm drain stenciling Create 2 videos D. Conduct 2 rain garden workshops	A. 2 walk/workshops conducted by Yr2 Q4 B. 2 presentations conducted by Yr1 Q4 2 water quality trainings conducted by Yr2 Q4 1-2 storm drain stenciling workshops by Yr2 Q4 C. Storm drains in key areas stenciled by Yr2 Q4 2 videos produced by Yr2 Q4 D. 2 rain garden workshops conducted by Yr2 Q 3	A. MOC and Twin Cities CDC B. NWRA C. Youth peer leaders D. Massachusetts Watershed Coalition

Each goal of the Clearwater Revival project offers many ways to incorporate elements of the collaborative problem-solving model.

1. Issue Identification, Community Vision and Strategic Goal Setting. One example of this element in our proposal is Goal 2 – Policy/Systems Analysis. Before we can propose an action to move forward on, we need to sit down together and talk about where the City is at and what is most needed to move it toward the goal of integrating GI for SWM. We need both the historical knowledge of City stakeholders and the expertise of NRWA’s Smart Growth Circuit Rider who has helped surrounding cities and towns with ordinances and bylaws related to SWM and LID at the table to identify issues of concern and prioritize them. This focused analysis can then key in on the most significant aspects of SWM and GI integration for the City.

2. Community Capacity Building and Leadership Development. By engaging the NRWA and Massachusetts Watershed Coalition in training the HZW stakeholders in issues around GI and SWM, we will help build capacity to integrate these concepts into vacant lot development as well as future City projects. By developing guidelines for residents around GI and creating a list of incentives that could be offered, stakeholders will be better able to lead the whole community on GI initiatives. The guideline for residents builds upon interests the HZW is already engaged in – namely developing a side yard abutter sales program. The GI booklet proposed will add value to these efforts.

Promoting youth as leaders in water pollution prevention efforts is a key part of this project. With the help of NRWA, youth will be able to understand the history of the Nashua River in the context of Fitchburg's development and understand the problem the City faces with SWM. Having the youth peer leaders be part of the solution: stenciling storm drains and learning about water quality analysis – will benefit the City and give the youth new knowledge and skills. We will tap into their knowledge of creating videos (as exemplified by their complete streets video) and have them create 2 videos around SWM, GI and how residents can prevent water pollution that can then be shown on Fitchburg's public access channel.

3. Consensus Building and Dispute Resolution. As an example of this CPS element, we want to work with the City and, with the expertise of the NRWA, find areas for either a focused policy or system analysis that will benefit the City while at the same time moving forward on efforts to protect the Nashua River. Collaboratively, our stakeholders will work together to come up with a focused area of concern that could be reviewed and promoted. This could be working to complete a SW ordinance for the City or working to design an effective tool that gives incentives to projects that integrate GI into their development strategy.

4. Multi-stakeholder Partnerships and Leveraging of Resources. Our logic model and workplan will be the grounding of our project. The various facets of our workplan allow multiple and frequent collaborative spaces for partners to engage with one another and develop a shared vision. For example, the HZW will work together to get a priority list of 10 vacant lots for the possible outdoor museum and then we will conduct field surveys of these sites with the expertise of the Massachusetts Watershed Coalition staff. Our team will engage on a design strategy that works for the space and gain the input of residents in that neighborhood about the project. Once a common vision for the site is developed, we will move toward an implementation plan that is coordinated with partners' time and expertise. We want to recruit residents and other stakeholders who are interested in the process and who can become champions for GI.

We can also leverage the expertise and interests of our partners and the HZW to enhance residents' knowledge about GI and water pollution prevention. For example, the BOH Director is interested in working with us during resident walks/workshops to talk about the medical take-back program in Fitchburg.

5. Constructive Engagement by Relevant Stakeholders. Creating a dialogue with City stakeholders, NRWA and Massachusetts Watershed Coalition can move the City on its way to developing a strong SWM plan that integrates GI. Our project has several places this can happen: training the HZW, engaging City stakeholders in a review of policy or systems, and working together to create the outdoor museum.

6. Sound Management and Implementation. Our MOA partners are at the table because they provide an expertise that was missing from our HZW. The workplan and logic model will provide a guide to our actions but each step requires its own plan and timeline within the larger framework. We will capitalize on the strengths of our team as we move through the various facets of the project and rely on our commitments to move projects forward.

7. Evaluation, Lessons Learned and Best Practices. Our continual evaluation of the partnership at meetings and by assessing progress toward goals on a regular basis will allow us to make sure all stakeholders' voices are heard and creative solutions identified. Neighborhood walk/workshops will let us engage with residents where they live and learn from them where stormwater is an issue. Combined with the workshop portion, we can empower residents to

make their own communities healthier by showing them steps they can take to prevent water pollution.

Building the outdoor museum will allow us to try out GI elements on a small scale and learn what is appropriate in other settings.

ii) How the organization and its partners will work together to address local issues

MOC is the lead applicant on this proposal and there are 4 MOA partners: 1) City of Fitchburg, 2) Nashua River Watershed Association (NRWA), 3) Massachusetts Watershed Coalition and 4) Twin Cities CDC.

As lead applicant, MOC's role is to convene meetings, manage the partnership, coordinate trainings, direct the activities of the peer leaders and neighborhood mobilizer, prepare reports and contract management. The **City's** role in the project is to provide knowledge of current SW issues in Fitchburg, historical knowledge of past initiatives regarding SW and GI and knowledge of city department procedures and systems. They can help guide the project in terms of trainings most needed, where storm drain stenciling would be most effective and what incentives for residential implementation of GI would be likely to succeed. The **NRWA's role** focuses on environmental education, training and policy analysis. They will train youth peer leaders on storm drain stenciling, water quality analysis and other aspects of water pollution and guide the policy/systems analysis. The **Massachusetts Watershed Coalition's** provides the technical knowledge of green infrastructure, training, and field surveys. They will assist with trainings, vacant lot surveys and implementation of GI in one vacant lot. **Twin Cities CDC** will provide their extensive knowledge of neighborhood characteristics to vacant lot prioritization and assist in neighborhood walk/workshops. They will be able to help us promote events and workshops using their resident networks.

The **City of Fitchburg** represents the **government sector**. As a municipal entity it brings the expertise of various departments to the table as well as knowledge of City procedures and systems. The **Department of Public Works (DPW)** has knowledge of City water issues, SW problem areas, data on CSO's, river quality and remediation techniques already tried. They also have staff and equipment that can help design and implement GI techniques for the outdoor museum. The **Planning Department** has knowledge of zoning policies and procedures and can assist with GIS mapping, policy and planning. The **Board of Health** has several programs we can integrate into this project – the medical take-back program and the hazardous waste collection days. The BOH Director is interested in leveraging outreach funds for the medical take-back program during the neighborhood walks/workshops. The **Mayor of Fitchburg** is supportive of the HZW and her office will be critical in advancing environmental and policy changes that reduce barriers to using GI for SWM.

Commitment: The Mayor commits staff time and meeting space, the Planning Department can assist with policy and procedure analysis and GIS mapping and the BOH can assist with sharing data about vacant lots as well as the medical take-back and hazardous waste collection programs. The Commissioner of Public Works enthusiastically supports our work and will commit staff to attend meetings, share data about SW issues, and assist with creating the GI museum.

Partner Quote: *The City of Fitchburg DPW enthusiastically supports your efforts to promote GI to help the City manage its SW in an environmentally responsible cost effective manner. Vacant lots might be ideal for rain gardens and grassed swales. Urbanized areas of Fitchburg were developed a century ago, creating congested neighborhoods with large impervious areas and little room for SWM. Vacant lots are often neighborhood eyesores with*

limited potential for future use. Getting stakeholders involved with developing and maintaining rain gardens would help DPW manage SW, foster pride in the neighborhood, promote community involvement and educate the public about SW. Identifying potential locations for these projects would be a valuable first step in the process. - Lenny Laakso, Commissioner of Public Works.

The **specific activities** the City of Fitchburg will be responsible for are: 1) attend meetings, 2) work with the NRWA to review local bylaws, ordinances or systems that promote or hinder GI for SWM and promote changes based on best practice review, 3) provide input for the GI resource booklet for residents and the list of potential incentives, 4) provide technical labor and assistance in building the outdoor museum

Both the **NRWA and Massachusetts Watershed Coalition** represent the **environmental sector**.

The **mission of the NRWA** is to *work for a healthy ecosystem with clean water and open spaces for human and wildlife communities, where people work together to sustain mutual economic and environmental well-being in the Nashua River watershed.* The NRWA has expertise about the Nashua River, water monitoring, storm drain stenciling, policy analysis, SWM, LID and environmental education. Their staff will help train youth, educate the HZW and conduct a local policy/systems analysis. Staff involved will be the NRWA Water Programs Director, the NRWA Water Monitoring coordinator and the NRWA Smart Growth Circuit Rider. **Commitment:** Training youth (History of the Nashua River, Introduction to Stormwater, Water Quality Sampling and Storm Drain Stenciling), training the HZW and a focused policy or system review.

Partner quote: *Thanks for inviting the NRWA to participate in the “Vacant Lot Group” – our program staff heartily agree that they would like to see NRWA participate. We have three staff people with expertise to contribute: Water Programs Director, Water Monitoring Coordinator and Smart Growth Circuit Rider.* – Elizabeth Ainsley Campbell, Executive Director

The **specific activities** the NRWA will be responsible for are: 1) attend meetings, 2) work with the City of Fitchburg to review local bylaws, ordinances or systems that promote or hinder GI for SWM and promote changes based on best practice review, 3) provide training to the HZW and youth peer leaders

The **mission of the Massachusetts Watershed Coalition** is *the protection and restoration of watershed ecosystems to sustain healthy rivers, streams, lakes, water supplies, terrestrial and aquatic habitats.* The **Massachusetts Watershed Coalition** has expertise in watershed planning, community outreach, LID, rain gardens and other infiltration practices.

Commitment: Staff time to attend meetings, resident workshops on rain gardens and other LID techniques, field survey of vacant lots and technical assistance in building the outdoor museum.

The **specific activities** the Massachusetts Watershed Coalition will be responsible for are: 1) attend meetings, 2) training the HZW, 3) field surveys of 10 vacant lots and assistance choosing the best lot for the outdoor museum 4) technical assistance building the outdoor museum 5) and 2 rain garden/LID workshops for residents.

The **Twin Cities CDC** represents the **local community development corporation**. Its mission and vision are as follows: *The Twin Cities Community Development Corporation (CDC) is a membership organization led by the diverse resident and business communities of Fitchburg and Leominster. We invest in and organize the residents of these cities to help build assets such as quality housing, good jobs, strong businesses and effective leaders. We envision healthy neighborhoods where residents choose to live, work, and invest, thereby forming a*

powerful, unified community.

Commitment: Staff time to attend meetings, assistance with neighborhood walk/workshops, and assistance in field surveys of vacant lots.

The **specific activities** the Twin Cities CDC will be responsible for are: 1) contribute research on vacant lot properties, 2) contribute to HZW meeting discussions, 3) attending and assisting with neighborhood walk audits.

Partnerships are maintained and sustained through shared vision and goals, trust and respect, creative and collaborative problem-solving and effective and timely management. These aspects are built into this project both formally and informally. As project goals are worked through and realized, a **shared vision** develops and partners begin to understand and trust one another. Our **continual evaluation of the partnership** at meetings and by assessing progress toward goals on a regular basis will allow us to make sure all stakeholders voices are heard and creative solutions identified. As the partnership develops, we will be able to find ways to build on the initiatives of one another to integrate SWM into new and existing initiatives as a way of sustaining the work. For example, the City has annual Ward clean-ups in spring and we can integrate storm drain cleaning into volunteers' work. As we learn about policy and system changes that can promote GI in the City, we can integrate these into City functioning so that the changes remain over time. Formal reports to EPA will keep us all accountable to our goals and workplan and give us an opportunity to reflect on elements that are successes as well as barriers we may be facing. This process then can give us a chance to celebrate our successes while problem-solving the barriers we face. As we progress toward our goals our increased expertise and collective knowledge will put us in a position to look for more grant funding to further our long-term goal of addressing SW pollution of the Nashua River and improving the health of vulnerable neighborhoods in Fitchburg.

V. Organizational Capacity and Programmatic Capability

MOC uses a sophisticated accounting system, *The Financial Edge* by Blackbaud, to manage grants and contracts from many types of funders and for multiple programs and services. The software contains all relevant modules necessary to maintain detailed activity (i.e., payables, receivables and general ledger). The system provides a wide range of capabilities that allow data to be reported in unlimited formats permitting MOC's Accounting Department to track and report separately all activity related to *Clearwater Revival*. Finances for our proposed project would be assigned to a Staff Accountant who would oversee all transactions related to the project and run reports for management to monitor, track, and report financial information.

MOC has developed a reputation among its funders, both public and private, of strong fiscal management and effective service delivery. MOC's total funding is currently in excess of \$17 million and comes from a variety of sources including over 50 state, federal, private and local grants and contracts. MOC adheres to a firmly scheduled and extensive annual audit of the agency's financial position, including related statements of activities, functional expenses and cash flow. MOC's last audit, for the period of October 31, 2012 and 2011, found the Agency to be fiscally solvent, in conformity with generally accepted accounting principles and meeting all requirements pertaining to effective internal control over compliance. The agency uses Results-Oriented Management and Accountability (ROMA) to ensure programs meet grant outputs and outcomes. The NWS Director provides ROMA reports to the Executive Director (ED) and Board of Directors monthly. The Board works closely with the ED and ensures adequate fiscal controls are in place and that the Agency is in compliance with all contract and grant

requirements. The ED is responsible for MOC's programs and services and is the direct supervisor to the three Division Directors who, in turn, supervise their Program Managers.

MOC has created a program structure to ensure *Clearwater Revival* will be successfully managed and completed. To accomplish the work-plan objectives, MOC is designating our existing Environmental Manager, Donna Wysokenski, as Project Manager due to her educational background in environmental science and policy along with her experience working with communities on environmental justice projects. She will be responsible for day to day activities and grant deliverables, oversee partner collaboration and coordinate vacant lot assessment activities. She will work with technical advisors to develop the QAPP. Her supervisor, Mary Giannetti, MOC's Director of Nutrition & Wellness (NWS) and Energy and Housing Divisions will participate on the HZW and provide management oversight through biweekly one-on-one meetings so that potential issues are brought to the senior management team for timely resolution. MOC can successfully achieve the goals of the Project. As exemplified in previous examples (*Fun 'n FITchburg*, work with FHA at Green Acres, Green Cleaning TURI project) MOC has the credibility, community networks, capacity and expertise to join with partners to complete *Clearwater Revival's* goals. MOC has experience successfully completing and managing assistance agreements and their reporting requirements. MOC has completed five years of a cooperative agreement with the Office of Family Planning and Office of Population Affairs on a Model-Based Male Family Planning project. Contractual, fiscal and reporting requirements have been successfully met.

VI. Qualifications of the Principal Investigator or Project Manager (PI/PM)

Key personnel will include existing highly qualified staff to timely complete Project.

Project Director (0.01 FTE on project.): Mary Giannetti, Director of the MOC NWS and Energy & Housing Divisions. Ms. Giannetti has 20 years of experience implementing and managing community health and housing programs at MOC demonstrating her ties, commitment and experience working with the affected community. She currently serves as: chair of the local health center, commissioner on the Fitchburg Housing Authority and is a gubernatorial appointee to the MA Nutrition Board. Ms. Giannetti is also a member of MA Department of Public Health Healthy Homes Advisory Committee, MA Public Health Association Act Fresh Steering Committee, Joint Coalition on Health and CHNA 9. Her state and community affiliations on environmental and public health efforts and ties to the local community will be an asset for this project. Role: Oversee development and implementation of the program; supervise PM; coordinate with external partners and internal MOC programs; participate on HZW; monitor project performance and track outputs and outcomes; and provide financial management of the grant.

Project Manager (0.4 FTE on project): Donna Wysokenski, has an: MA in Environmental Science and Policy, MS in Molecular and Cell Biology, and graduate certificate in Ecology and the Human Spirit. As a graduate student, Donna collaborated with professors, community and environmental organizations on a four-year community-based participatory research project funded by the National Institute of Environmental Health Sciences. She researched pediatric asthma in schools, conducted environmental health listening sessions among minority populations and led neighborhood data collection walks with residents to learn about particulate matter. She is currently the Environmental Manager at MOC (4 years) responsible for overseeing the Childhood Lead Poisoning Prevention Program and coordinating a multi-year, multi-stakeholder partnership to convert a large open space in a Fitchburg Housing Authority complex into a natural play space. For two years, she managed grants from the Toxics Use Reduction

Institute to offer green cleaning workshops for hundreds of North Central MA residents focusing on low-income, Spanish and Hmong residents. Donna coordinates the Healthy Zoning Workgroup (HZW) and was a key collaborator for the vacant lot Health Impact Assessment in 2013. Donna participates in the City of Fitchburg's recycling and open space committees and the Montachusett Regional Trail Coalition. Role: Oversee grant activities including: coordinating meetings; facilitating trainings; staffing the HZW; coordinating the neighborhood walks/workshops, managing the partnership and project reporting, preparation of QAPP.

VII. Past performance in Reporting on Outputs and Outcomes

MOC manages over 50 grants from Federal, State and private funders with successful documented progress toward outputs and outcomes. Below is one example from each source.

1. Model-Based Male Family Planning (FPR006010A), \$627,000(5 years) HHS OFP, David Johnson, 240-453-2841, Progress Documentation: Monthly outreach activities, Workplan milestones achieved, quarterly outputs transmitted, midyear grantee presentation, and yearly progress report submitted.

2. Childhood Lead Poisoning Prevention (INTF7900MM3701516139), \$48,550 FY2013 (\$433,542 from 2007-2013), MA DPH, Paul Hunter, 617-624-5585, Progress Documentation: Pre and post tests during community presentations, monthly outreach activities, Quarterly progress reports submitted.

3. Green and Clean in North Central Massachusetts, \$20,000 2012-2013; \$25,000 2011-2012 Toxics Use Reduction Institute, Joy Onasch, 978-934-4343, Progress Documentation: Pre and post tests and follow-up phone calls to workshop participants, Interim progress meeting with funder, interim and final progress reports submitted, poster presentation at Statehouse.

VIII Expenditure of Awarded Grant funds- If successfully awarded funding for this grant, MOC has identified existing staff to direct and manage the grant which will allow for a timely start up and execution of activities. MOC's Finance and Administration Depts. will set up a specific fund account to ensure that money can be received and expenditures monitored. This grant builds upon the work of the existing HZW and Strategy Experts have been identified and are poised to have sub award agreements executed within 30 days upon award. Monthly financial reports will be monitored by the project director and manager to ensure that grant funds are expended in a timely manner and are in line with work plan activities and time frame.

IX Quality Assurance Project Plan (QAPP) Information The project will need a QAPP since we will collect water samples, use existing databases and historical research, implement deed searches, create a new database and use the information to make recommendations on environmental decisions.

Attachment 3

**POLICY and SYSTEMS REVIEW REPORT
FOR THE CITY OF FITCHBURG, MASSACHUSETTS**

January 5, 2016

FINAL REVIEW COPY

By Mark Archambault, Smart Growth Circuit Rider

Nashua River Watershed Association

Executive Summary 2

Definitions 3

I. Review of current Fitchburg policies and practices relating to Green Infrastructure and Low-Impact Development (LID).....4

 a. Stormwater Management and Erosion Control Ordinance4

 b. Wetlands Protection Ordinance and Regulation6

 c. Fitchburg’s 2003 MS4 General Permit7

 d. Rules and Regulations for Special Permits and Rules and Regulations for the Subdivision of Land7

II. Summary of Recommendations from the UMASS Green Fitchburg Report..... 9

Green Fitchburg: Opportunities, Strategies and Visions for the Future (UMASS Amherst Department of Landscape Architecture and Regional Planning)

III. Summary of Planning and Infrastructure Policies Fitchburg can adopt to implement Green Infrastructure and LID 10

IV. Bibliography and References 11

Executive Summary

This 'Policy and Systems Review' report assessing the City of Fitchburg's capacity to promote and implement Green Infrastructure (G) and Low-Impact Development (LID) approaches to site design and stormwater management, is one component of a wider project titled '**Clearwater Revival**' under the auspices of the **Montachusett Opportunity Council (MOC)**, which is a social and environmentally-oriented non-profit agency based in Fitchburg, Massachusetts.

The scope of work for the Policy and Systems Review component of the Clearwater Revival project states that "*We will work with the City of Fitchburg to review local bylaws, ordinances or systems that promote or hinder GI for stormwater management and promote changes based on best practice review.*" It then goes on to state that "*We will assess the City's systems and policies to see how Green Infrastructure (GI) and Low-Impact Development (LID) methods can be integrated into procedures and policies and what barriers may exist.*" In other words, how can the City of Fitchburg move forward in implementing GI and LID practices?

One of the primary tasks in the policy and systems review process is to assess the effectiveness of the City of Fitchburg's ordinances, regulations and policies in promoting Low-Impact Development (LID) and Green Infrastructure (GI). The NRWA's Smart Growth Circuit Rider reviewed the following policy and planning documents to assess whether they adequately promote LID and GI:

- Stormwater Management and Erosion Control Ordinance
- Wetlands Protection Ordinance and Regulations
- The City's 2003 MS4 General Permit (EPA Stormwater Program)
- Special Permit and Site Plan Regulations
- Subdivision Rules and Regulations

In brief, these planning documents, which, with the exception of the Stormwater Management and Erosion Control Ordinance, were written prior to the current emphasis on LID and GI practices for stormwater management; do not yet form the framework upon which an effective GI program can be assembled. For the most part, there is very little mention of GI and LID practices in any of the above listed planning and regulatory documents.

The City of Fitchburg therefore has much it can do to address GI and LID approaches not only to stormwater management, but for city planning in general. While this current state of affairs may seem unfortunate, it also provides an opportunity for the City to adopt *coordinated* LID and GI policies and practices that span the scope of all of the above land-use regulations and the City of Fitchburg Boards and Departments that implement them.

There is little standing in the way in terms of obstacles to developing a comprehensive GI and LID approach to stormwater management and site planning. GI and LID practices can be written into the various planning and regulatory documents described in this report such that they are “all on the same page” and unified across disciplines.

The City’s Planning Department and Department of Public Works should take the lead in developing such a set of comprehensive and coordinated regulations. The Conservation Commission can also play an important role by considering an increase in its no-disturbance and no-build setbacks within the wider 100 foot buffer zone called for by the Massachusetts Wetlands Protection Act.

Definitions

Bioretention is the process in which contaminants and sediments are removed from stormwater runoff. Stormwater is collected into the treatment area which consists of a grass buffer strip, sand bed, ponding area, organic layer or mulch layer, planting soil and plants. Runoff passes first over or through a sand bed, which slows the runoff’s velocity, distributes it evenly along the length of the ponding area, which consists of a surface organic layer and/or groundcover and the underlying planting soil.

Buffer Zone refers to an area measured from the edge of a wetland or water body within which a local Conservation Commission has regulatory jurisdiction, which, in the case of the Massachusetts Wetlands Protection Act, applies only to activities likely to impact the wetland or water body itself. However, towns which have adopted Local Wetland Protection Bylaws can regulate activities in the buffer zone itself by virtue of it being declared a ‘resource area’.

Green Infrastructure is defined as a network of decentralized stormwater management practices, such as rain gardens, bioretention systems, and green roofs that can capture, infiltrate, and treat stormwater thereby reducing stormwater runoff and improving the health of receiving waters.

Low-Impact Development (LID) refers to more sustainable land development practices that result from a site planning process that first identifies critical natural resources, then determines appropriate areas for development and then uses mainly non-structural ‘green’ methods of stormwater management. LID also incorporates and refers to a range of best management practices (BMPs) that preserve the natural hydrology of the land, often through the use of natural and planted vegetation.

No-Build Zone designates the area within a wider wetland buffer zone within which no primary and secondary structures are allowed to be constructed. Some land disturbance may be acceptable provided it is permitted through the applicable Order of Conditions issued by the Conservation Commission.

No-Disturbance Zone designates the area within a wider buffer zone within which no activities that break the land surface or destroy existing vegetation are permitted. Some limited exceptions may be made for control of invasive species or certain low-impact projects (i.e. trail construction) provided they are permitted by the local Conservation Commission.

I. **Review of current Fitchburg policies and practices relating to Green Infrastructure and Low-Impact Development (LID)**

One of the primary tasks in the policy and systems review process is to assess the effectiveness of the City of Fitchburg's ordinances, regulations and policies in promoting Low-Impact Development (LID) and Green Infrastructure (GI). The NRWA's Smart Growth Circuit Rider reviewed the following policy and planning documents to assess whether they adequately promote LID and GI:

- Stormwater Management and Erosion Control Ordinance
- Wetlands Protection Ordinance and Regulations
- The City's 2003 MS4 General Permit (EPA Stormwater Program)
- Special Permit and Site Plan Regulations
- Subdivision Rules and Regulations

In brief, these planning documents, which, with the exception of the Stormwater Management and Erosion Control Ordinance, were written prior to the current emphasis on LID and GI practices for stormwater management; do not yet form the framework upon which an effective GI program can be assembled. While this may seem unfortunate, it also provides an opportunity for the City to adopt coordinated LID and GI policies and practices that span the scope of all of the above land-use regulations.

a. Stormwater Management and Erosion Control Ordinance

Fitchburg's Stormwater Management and Erosion Control Ordinance was adopted in 1999, with several amendments since then. The Department of Public Works is the authorized enforcement agency. Though this ordinance does not directly mention or encourage LID or GI, it does include provisions that would support amendments that would encourage a greater emphasis on LID and GI. These include:

- Objectives including "*minimize the volume and rate of stormwater which is discharged to rivers, streams, reservoirs, lakes and combined sewers*";
- "*Provide stormwater facilities that are attractive, maintain the natural integrity of the environment, and are designed to protect the public safety*".
- The definition of 'Best Management Practices' (BMPs), mentions that they are "*either structural or **non-structural devices** that temporarily store or treat urban runoff...*" LID and GI usually involve non-structural practices and stormwater treatment areas.
- A definition of 'Pre-Treatment' is provided, which can be tied to LID and GI practices once those are properly addressed in the ordinance.
- The threshold for needing to submit a stormwater management plan is the creation of 4,000 sq.ft. or more of impervious surfaces, or any activity that disturbs one acre or more of land.

Recommendations:

- Add definitions of Low-Impact Development and Green Infrastructure to the definitions section.
- The purpose and objective section could include statements encouraging the use of non-structural stormwater management practices, including LID, and provide examples of such practices.
- Mention that non-structural stormwater management practices are encouraged and preferred over structural practices when possible and advisable. For example, the Town of Easthampton, MA, requires stormwater permit applicants to demonstrate that they have considered the use of LID and GI stormwater techniques in their plans.
- The stormwater ordinance can be amended to set stormwater volume reduction standards, as has been implemented in Philadelphia, requiring that developments larger than 10,000 sq.ft. retain the first inch of rainfall on-site.
- Philadelphia's ordinance also calls for disconnecting impervious surfaces by directing runoff to pervious areas; whether naturally occurring or constructed LID facilities such as rain gardens.
- Some of the LID and GI tools recommended in Philadelphia include: http://phillywatersheds.org/what_were_doing/green_infrastructure/tools
- Philadelphia has also developed a list of programs in which various approaches to GI are to be applied: http://phillywatersheds.org/what_were_doing/green_infrastructure/programs
- The City of Fitchburg should consider applying some of the tools and programs developed for Philadelphia to its own urban core.
- The Central Massachusetts Stormwater Coalition also has created a toolbox for homeowners: http://www.centralmastormwater.org/pages/crsc_toolbox/documents which can assist homeowners with residential-scale LID solutions for their properties. The Residential stormwater management page is here: http://www.centralmastormwater.org/Pages/crsc_toolbox/Residential%20Stormwater_2%20pages.pdf



Rain Garden on Church Property in Leominster, MA Residential Rain Garden in Leominster, MA
Photos: Ed Himlan, Massachusetts Watershed Coalition

b. Wetlands Protection Ordinance and Regulations

The City's Wetlands Protection Ordinance and Rules and Regulations were last amended in the spring of 2012. The Ordinance and Regulations mention erosion and sedimentation control, storm damage prevention and water quality as resource area values.

One of the better provisions of the ordinance and regulations is that they address 'cumulative adverse impacts', which "*means the effect on a wetland or buffer resource area that is significant considering the effect of one activity in combination with other activities that have occurred, are occurring or are reasonably likely to occur within the resource area, whether such activities have occurred or are contemplated as a separate phase of the project, or as a result of unrelated activities on adjacent land*". LID and GI practices, which can be small in scale and sited more easily than engineered stormwater approaches, should be well-suited for addressing cumulative adverse impacts.

Section 178.11 of the Ordinance designates Buffer Zones as resource areas in their own right, which is a good foundation upon which LID and GI practices can be applied. The Ordinance in this section states that "*The Commission may establish, in its regulations, design specifications, performance standards, and other measures and safeguards, including setbacks, no-disturb areas, no-build areas, and other work limits for protection of such lands, including without limitation strips of continuous, undisturbed vegetative cover, ...*".

The Regulations, though not addressing LID and GI directly, do contain several provisions that would dovetail nicely with such non-structural approaches to stormwater management. Section 3.2 of the Regulations call for a 20 foot no-disturbance zone for residential development and 50 feet for non-residential development. They also designate a 25 foot no-build zone for residential development and 75 feet for non-residential development. These no-disturbance and no-build setbacks could be widened to provide even more treatment of stormwater before it enters wetlands and surface waters. These setbacks can also be tied into LID and GI provisions.

Section 3.4 of the Regulations calls for the installation of a silt prevention barrier between the proposed limit of disturbance and the edge of all wetlands so as to intercept sediment-laden runoff. This section could also specify several LID and GI techniques to assist in sedimentation control.

Recommendations:

- First, the scientific literature on the effectiveness of various buffer widths in protecting water quality cite the need for no-disturbance zones in the range of at least 50 (fifty) feet in most cases to remove sediments to which nutrients like phosphorous and nitrates adhere. Expanding the no-disturbance zone for residential development to 50 feet and 75 feet for non-residential development in areas outside Fitchburg center would provide better protection to wetlands and associated water resources.

- For Fitchburg center, a range of LID and GI practices can be specified for areas within 100-feet of wetlands and surface waters. Installation of rain gardens and street trees in special container boxes that capture and treat stormwater runoff could help to make up for the lack of a natural vegetated buffer in the urban center.

c. Fitchburg's 2003 MS4 General Permit

Fitchburg's 2003 MS4 General Permit addresses the seven minimum controls that the USEPA requires of a municipal small separate stormwater systems (MS4), but does not mention or specify the use of LID and GI systems as part of the plan to meet its stormwater management goals and objectives. The 2003 permit only requires that new development sites greater than one acre, and that are within the 100-foot wetland buffer zone or riverfront area, treat and infiltrate the first inch of runoff. Fitchburg's new MS4 permit will require that all sites over one (1) acre, including redevelopment, must infiltrate and/or treat the first one (1) inch of runoff.

Recommendations:

- The new MS4 General Permit application should cite and require GI and LID practices whenever feasible for applicable projects.
- The new MS4 General Permit can specify which City ordinances and regulations will be amended to better provide for GI and LID approaches to site design and stormwater management.

d. Special Permit and Site Plan Rules and Regulations and Rules and Regulations for the Subdivision of Land

Fitchburg's Special Permit and Site Plan Rules and Regulations do not contain many provisions for stormwater management and do not mention LID or GI at all. In the Subdivision Regulations, Plan Requirement # 7 calls for "*plans for handling stormwater drainage*", but provides no guidance on what such plans should contain. In the Site Plan Regulations, which refer back to Section 181.945 of the Fitchburg Zoning Ordinance, a provision calls for "*make adequate provision for utilities and stormwater drainage consistent with the functional requirements of the Planning Board's Subdivision Rules and Regulations*". This would be a good location to mention and describe LID and GI approaches to stormwater management.

Recommendations:

- Examine the feasibility of requiring narrower roads in new residential subdivisions. This can go a long way towards both reducing maintenance costs, but also the amount of stormwater generated.
- Consider allowing or expanding the use of shared parking lots in the more densely developed parts of Fitchburg for new development and redevelopment.

- The maximum percentage of impervious surfaces allowed for new development and redevelopment, for both 'green' sites and redevelopment, can be specified so as to reduce sheet flow and the need for stormwater treatment facilities.
- The subdivision and site plan regulations can require that whenever an existing street or parking lot undergoes major repairs or is scheduled for reconstruction, that LID and GI practices such as rain gardens, tree box planters and grassed swales be installed.
- The subdivision regulations can be amended so as to reduce the required width of new residential streets, which will simultaneously function as a traffic calming measure, and reduce the volume of stormwater runoff.
- Both the subdivision and site plan regulations can require that LID and GI methods of collecting and treating stormwater be given consideration in the design process. These regulations can provide incentives for applicants to use LID and GI stormwater management techniques.
- The Planning Department, in coordination with Public Works, should consider establishing a maximum percentage of impervious surfaces to be allowed in new development. Such a standard need not be the same for all zoning districts, but could vary based on land-use. 'Urban' and 'commercial' districts, for example, would be allowed a higher percentage in exchange for a lower maximum in more outlying low density residential and rural areas.

II. Summary of Recommendations from the UMASS Green Fitchburg Report

Green Fitchburg: Opportunities, Strategies and Visions for the Future (UMASS Amherst Department of Landscape Architecture and Regional Planning)

In the spring of 2009, a Landscape Sustainability Studio class from UMASS, Amherst, under the direction of Professor Jack Ahern Ph.D., released a report titled "Green Fitchburg: Opportunities, Strategies and Visions for the Future" (*hereafter called the 'UMASS Study'*). The class examined the feasibility of and offered recommendations on the implementation of GI and LID approaches to landscape design and stormwater management. They focused on three primary areas in Fitchburg: 1. The North Nashua River Corridor, 2. Downtown Fitchburg, and 3. Water Street (Route 12 Corridor). This synopsis of the UMASS Study and its recommendations will focus primarily on downtown Fitchburg, with some mention of the Water Street area.

First, for the Water Street / Route 12 corridor the UMASS Study has three primary goals and objectives:

1. **Install GI within and adjacent to the street layout of Water Street by;** a. promoting cooperation of business owners with large street frontages to create a neighborhood image, b. reducing curb cuts and improving sidewalks, c. constructing rain gardens to reduce and remove contaminants from street and parking lot stormwater runoff, d. planting street trees to provide shade, reducing runoff and cleaning the air.
2. Develop the Twin Cities Rail Trail as a separate-grade facility paralleling Water Street
3. Promoting the redevelopment of Fitchburg's older neighborhoods by installing green infrastructure in the Patch Neighborhood.

For a general recommendation, the UMASS Study notes that the most practical places to incorporate GI, such as bioswales and rain gardens, is near existing catch basins.

The UMASS Study recommends that for Downtown Fitchburg:

1. Reconfigure the street layout of Main Street, in part by, a. installing rain gardens and b. planting of street trees to provide shade and reduce stormwater volume.
2. Redesign the vacant lot(s) west of the theater
3. Provide safer corridors from parking garages to Main Street

The plan for Downtown Fitchburg centers in large part of an extensive network of street trees. The UMASS Study includes maps showing where new street trees are recommended in the Main Street Corridor.

The UMASS Study then identifies four primary areas where the installation of GI and LID is most recommended:

1. Upper Common, 2. Bijou Theatre Lot, 3. Verizon Building and 4. Lower Main Street

The report goes into detail on how each of these areas can be improved by the installation of GI and LID stormwater management facilities.

III. Summary of Planning and Infrastructure Policies Fitchburg can adopt to implement Green Infrastructure and LID

As seen above, Fitchburg's existing set of ordinances and regulations barely mention GI and LID approaches to site design and stormwater management. This is both a problem and an opportunity.

For example, whenever an existing street is reconstructed or a commercial, office or industrial site redeveloped, GI and LID practices can be incorporated into the design both through a reduction of impervious surfaces and mandatory installation of new LID facilities such as rain gardens, bioswales, pervious pavement and the like.

The Planning and Public Works Departments can coordinate efforts to revise pertinent sections of the City's Zoning Ordinance, Site Plan and Subdivision Regulations, Stormwater Management Ordinance, and Wetlands Protection Bylaw so as to incorporate GI and LID practices in a coordinated fashion.

A good example of a City that has taken a comprehensive approach to GI and LID practices is Buffalo, New York. In its 'Green Code' (Zoning), the City of Buffalo:

- Mandates that all future transportation projects be implemented as 'Complete Green Streets' that incorporate GI into their design and construction whenever possible.
- Seeks to ensure that all public parks, plazas and other public venues be built to integrate stormwater management seamlessly into their design in a manner that enhances their total quality of life.
- Requires that all new development projects, including parking lots, provide for 100% on-site stormwater management for up to 2 inch rain events through the use of GI including measures such as bioswales, rain gardens, flow-through trenches, green roofs, etc.
- Seeks to ensure that all future demolitions incorporate stormwater management features on the resulting vacant lots that will include site grading and fill requirements, green infrastructure and, where appropriate, possible use as collective receiving sites for adjacent multi-property downspout disconnections.

The City of Fitchburg can seek to adopt some or all of the above practices that have proven effective in Buffalo, NY, a cold weather city that has much in common with Fitchburg, albeit being a large city.

In Massachusetts, the Town of Franklin has perhaps gone the furthest in developing a comprehensive GI implementation strategy for their town. The March 2014 EPA report # EP-C-11-009 prepared for the Town of Franklin goes into a great detail of technical detail on particular GI and LID approaches to stormwater management. The City of Fitchburg should consider adopting as references the technical information provided in this report, as it would simplify the process of adopting GI and LID standards and regulations.

IV. Bibliography and References

American Planning Association. January 2013. "***Green Infrastructure: A Landscape Approach***". APA Planning Advisory Service Report Number 571.

Buffalo Niagara Riverkeeper. March 2011. "***Green Infrastructure Solutions to Buffalo's Sewer Overflow Challenge***."

Nashua River Watershed Association. Spring 2011. "***An Introduction to Water Resource Protection in Massachusetts and New Hampshire: A Guide to Information Sources for Municipal Boards and Citizens***".

Pioneer Valley Regional Planning Commission. "***Pioneer Valley Green Infrastructure Plan***"

Town of Groton, Massachusetts. "***Chapter 198. Stormwater Management – Low Impact Development Bylaw***." Amended October 2015.

United States Environmental Protection Agency (US EPA). March 2014. "***Green Infrastructure Implementation Strategy for the Town of Franklin, Massachusetts***". EPA Report # EP-C-11-009

University of Massachusetts, Department of Landscape Architecture and Regional Planning. Spring 2009. "***Green Fitchburg: Opportunities, Strategies and Visions for the Future***".

Attachment 4



City of Fitchburg, Massachusetts

PLANS FOR THE IMPROVEMENTS TO FIRST AND RAILROAD STREET PARK

Railroad and First Street
Fitchburg, Massachusetts

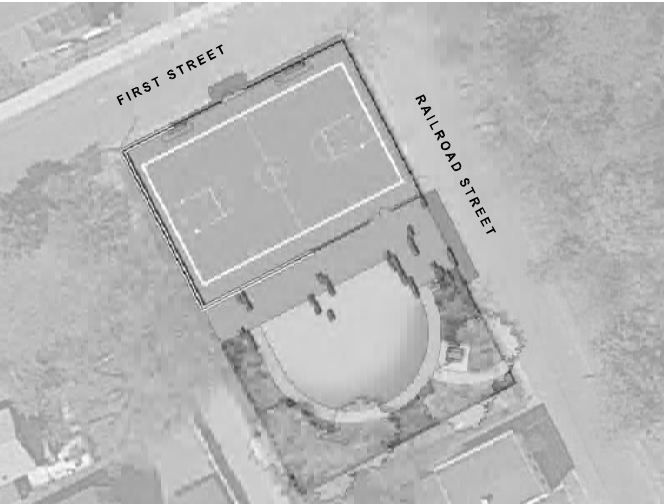

AS-BUILT DOCUMENTS

Locus Map



RAILROAD PARK
First Street & Railroad Street



85 Devonshire Street, 3rd Floor
Boston, MA 02109
(617) 412-4480 (800) Sampson
www.westonandsampson.com
Project contact: Gene Bollinger
857.415.3884

SHEET INDEX

CV-1	COVER SHEET
L1.01	EXISTING CONDITIONS PLAN
L2.01	SITE PREPARATION & DEMOLITION PLAN
L3.01	LAYOUT & MATERIALS PLAN
L4.01	GRADING, DRAINAGE & UTILITY PLAN
L5.01	PLANTING PLAN
L6.01 - L6.03	SITE CONSTRUCTION DETAILS

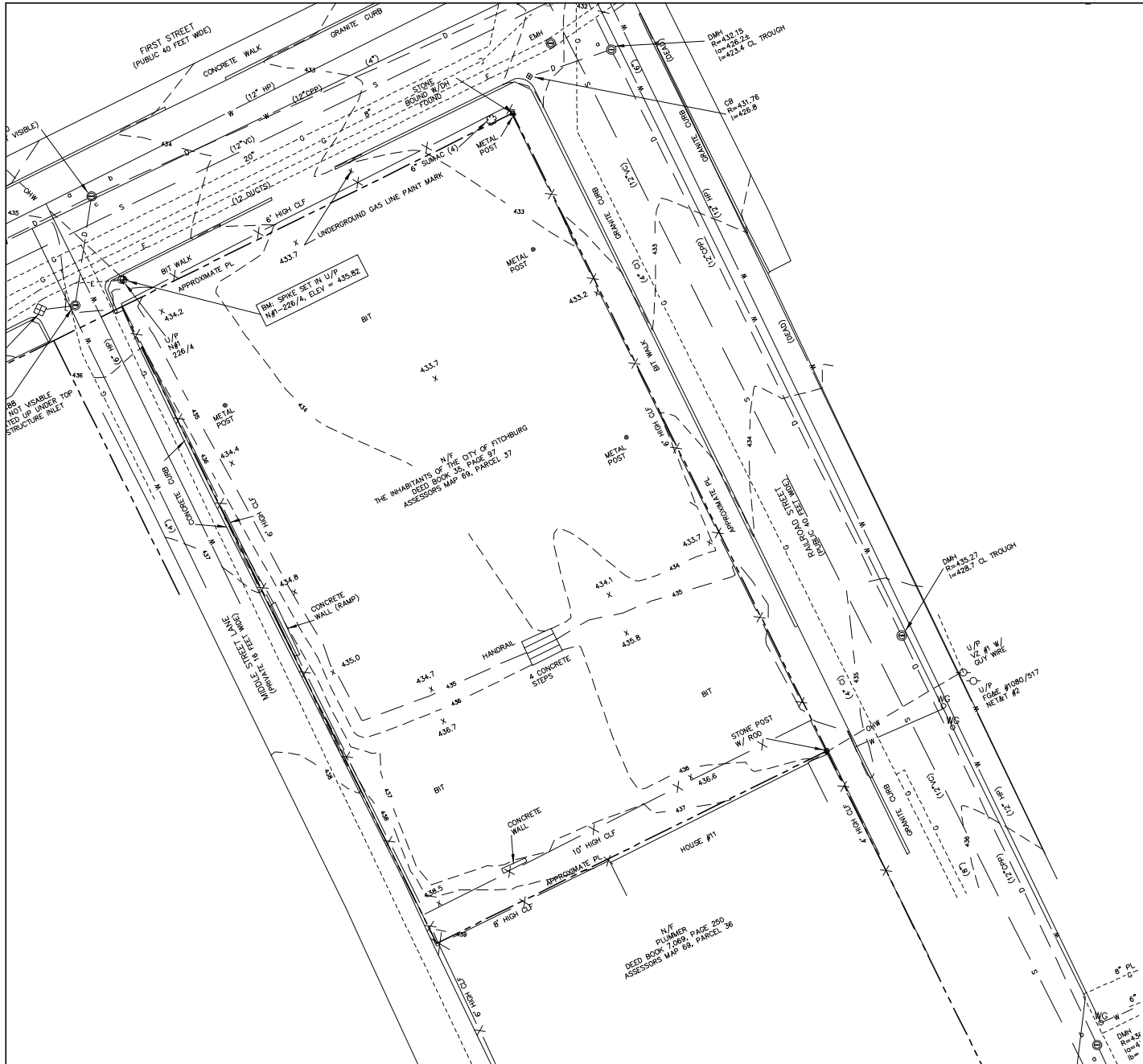

EXISTING CONDITIONS LEGEND

- PROPERTY LINE, SEE NOTE 4
- BM BENCH MARK
- CBDI CATCH BASIN/DRCP INLET
- CB CATCH BASIN
- CL CENTER LINE
- CLF CHAIN LINK FENCE
- CPP CORRUGATED PLASTIC PIPE
- D DRAIN LINE
- DWH DRAIN MANHOLE
- E ELECTRIC LINE (DUCT)
- ELEV ELEVATION
- EMH ELECTRIC MANHOLE
- FG&C # FITCHBURG GAS AND ELECTRIC COMPANY W/ POLE NUMBER
- G GAS LINE
- HP HIGH PRESSURE
- I INVERT ELEVATION
- NET&T # NEW ENGLAND TELEPHONE AND TELEGRAPH COMPANY W/ POLE NUMBER
- NG # NATIONAL GRID COMPANY W/ POLE NUMBER
- R ELEVATION
- S SANITARY SEWER LINE
- SMH SANITARY SEWER MANHOLE
- TYP TYPICAL
- U/P UTILITY POLE
- W WATER LINE
- W/ WITH
- WG WATER GATE
- VZ # VERIZON COMPANY W/ POLE NUMBER
- 434 EXISTING CONTOUR (TYP)
- 435.8x SPOT GRADE (TYP)

SURVEY NOTES

1. OWNER OF RECORD: CITY OF FITCHBURG
C/O COMMUNITY DEVELOPMENT OFFICE
16 BOLLIVER DRIVE
FITCHBURG, MA 01420
2. EXISTING CONDITIONS SHOWN HEREON ARE BASED UPON AN ACTUAL GROUND SURVEY PERFORMED BY LAPRAD LAND SURVEYING ON JANUARY 28, 2016.
3. ELEVATIONS ARE REFERENCED TO THE NORTH AMERICAN VERTICAL DATUM OF 1988.
4. NO PROPERTY LINE SURVEY PERFORMED AT THIS TIME. PROPERTY LINES AS SHOWN ARE APPROXIMATE ONLY AND ARE BASED UPON DEEDS, PLANS OF RECORD IN ADDITION TO ASSESSORS RECORDS AND MONUMENTS RECOVERED IN THE FIELD.
5. EXISTING UTILITY LINES SHOWN ON THIS DRAWING ARE FROM AVAILABLE INFORMATION AND ARE APPROXIMATE LOCATIONS. THERE MAY BE EXISTING LINES OTHER THAN THOSE INDICATED. THE OWNER, THE OWNER'S REPRESENTATIVE, NOR LAPRAD LAND SURVEYING ASSUME RESPONSIBILITY FOR DAMAGES INCURRED AS A RESULT OF UTILITIES OMITTED OR INACCURATELY SHOWN BEFORE PLANNING FUTURE CONNECTIONS. THE PROPER PUBLIC UTILITY ENGINEERING DEPARTMENT SHOULD BE CONSULTED.

Project
CITY OF FITCHBURG



Improvements to
First and Railroad
Street Park



85 Devonshire Street, 3rd Floor
Boston, MA 02109
(617) 412-4450 (508) 548-5000
www.spurr-engineering.com

Consultant

Revisions:

Rev	Date	Description
1	06.22.16	GRADING REVISIONS
2	05.30.17	AS-BUILT

Scale:

AS BUILT DOCUMENTS

Date:	01.30.2017
Scale:	AS SHOWN
Drawn By:	CB/BR
Reviewed By:	
Checked By:	ERB
Approved By:	ERB

Drawing Title:
EXISTING CONDITIONS PLAN

Sheet Number:
L1.01

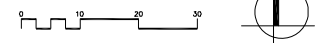

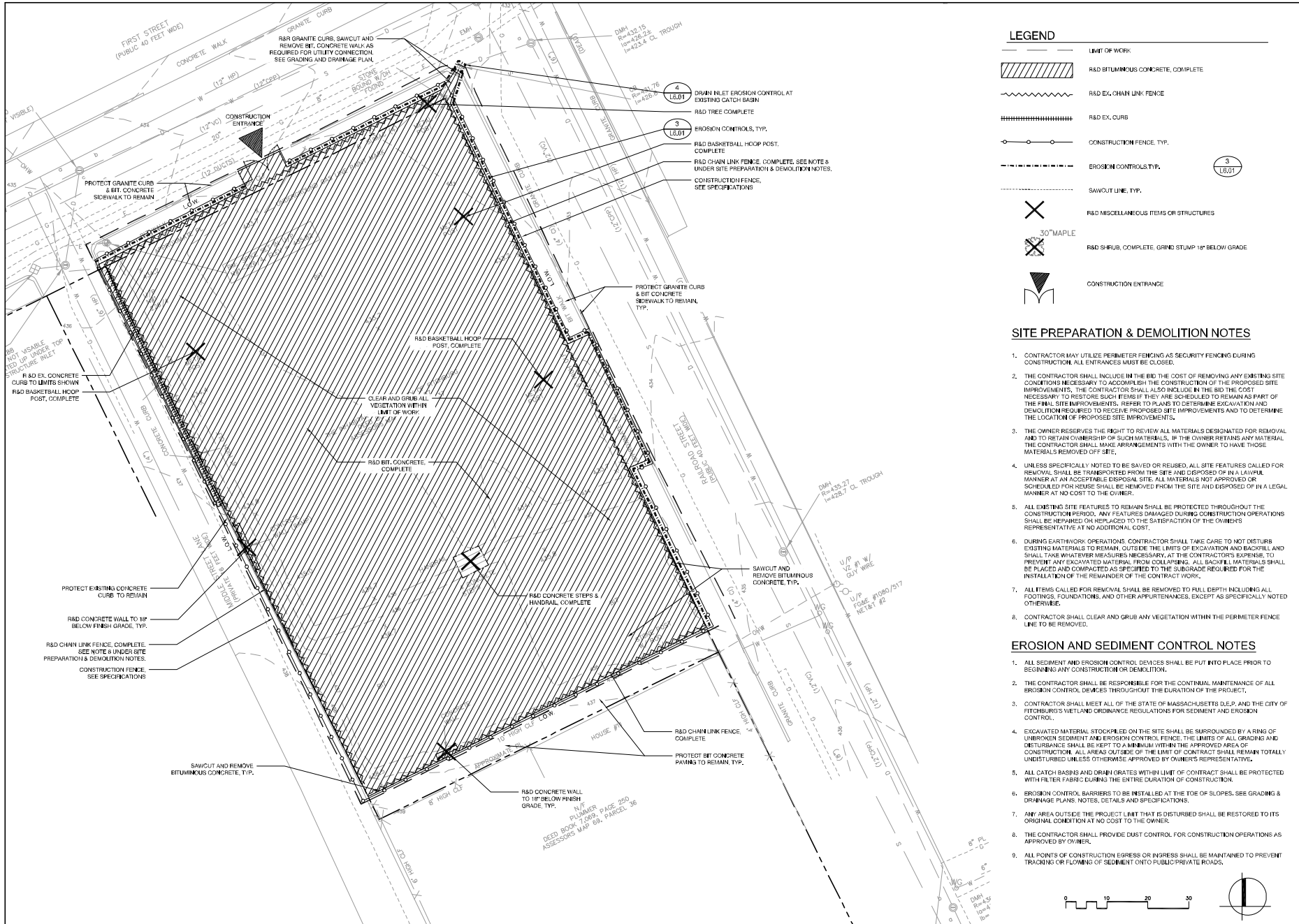

LEGEND

- LIMIT OF WORK
- R&D BITUMINOUS CONCRETE, COMPLETE
- R&D EX CHAIN LINK FENCE
- R&D EX CURB
- CONSTRUCTION FENCE, TYP.
- EROSION CONTROLS, TYP.
- SAWCUT LINE, TYP.
- R&D MISCELLANEOUS ITEMS OR STRUCTURES
- 30" MAPLE
- R&D SHRUB, COMPLETE. GRIND STUMP 18" BELOW GRADE
- CONSTRUCTION ENTRANCE

SITE PREPARATION & DEMOLITION NOTES

- CONTRACTOR MAY UTILIZE PERIMETER FENCING AS SECURITY FENCING DURING CONSTRUCTION. ALL ENTRANCES MUST BE CLOSED.
- THE CONTRACTOR SHALL INCLUDE IN THE BID THE COST OF REMOVING ANY EXISTING SITE IMPROVEMENTS. THE CONTRACTOR SHALL ALSO INCLUDE IN THE BID THE COST NECESSARY TO RESTORE SUCH ITEMS IF THEY ARE SCHEDULED TO REMAIN AS PART OF THE FINAL SITE IMPROVEMENTS. REFER TO PLANS TO DETERMINE EXCAVATION AND DEMOLITION REQUIRED TO RECEIVE PROPOSED SITE IMPROVEMENTS AND TO DETERMINE THE LOCATION OF PROPOSED SITE IMPROVEMENTS.
- THE OWNER RESERVES THE RIGHT TO REVIEW ALL MATERIALS DESIGNATED FOR REMOVAL AND TO RETAIN OWNERSHIP OF SUCH MATERIALS. IF THE OWNER RETAINS ANY MATERIAL THE CONTRACTOR SHALL MAKE ARRANGEMENTS WITH THE OWNER TO HAVE THOSE MATERIALS REMOVED OFF SITE.
- UNLESS SPECIFICALLY NOTED TO BE SAVED OR REUSED, ALL SITE FEATURES CALLED FOR REMOVAL SHALL BE TRANSPORTED FROM THE SITE AND DISPOSED OF IN A LAWFUL MANNER AT AN ACCEPTABLE DISPOSAL SITE. ALL MATERIALS NOT APPROVED OR SCHEDULED FOR REUSE SHALL BE REMOVED FROM THE SITE AND DISPOSED OF IN A LEGAL MANNER AT NO COST TO THE OWNER.
- ALL EXISTING SITE FEATURES TO REMAIN SHALL BE PROTECTED THROUGHOUT THE CONSTRUCTION PERIOD. ANY FEATURES DAMAGED DURING CONSTRUCTION OPERATIONS SHALL BE REPAIRED OR REPLACED TO THE SATISFACTION OF THE OWNER'S REPRESENTATIVE AT NO ADDITIONAL COST.
- DURING EARTHWORK OPERATIONS, CONTRACTOR SHALL TAKE CARE TO NOT DISTURB EXISTING MATERIALS TO REMAIN, OUTSIDE THE LIMITS OF EXCAVATION AND BACKFILL AND SHALL TAKE WHATEVER MEASURES NECESSARY, AT THE CONTRACTOR'S EXPENSE, TO PREVENT ANY EXCAVATED MATERIAL FROM COLLAPSING. ALL BACKFILL MATERIALS SHALL BE PLACED AND COMPACTED AS SPECIFIED TO THE SUBGRADE REQUIRED FOR THE INSTALLATION OF THE REMAINDER OF THE CONTRACT WORK.
- ALL ITEMS CALLED FOR REMOVAL SHALL BE REMOVED TO FULL DEPTH INCLUDING ALL FOOTINGS, FOUNDATIONS, AND OTHER APPURTENANCES, EXCEPT AS SPECIFICALLY NOTED OTHERWISE.
- CONTRACTOR SHALL CLEAR AND GRUB ANY VEGETATION WITHIN THE PERIMETER FENCE LINE TO BE REMOVED.

EROSION AND SEDIMENT CONTROL NOTES

- ALL SEDIMENT AND EROSION CONTROL DEVICES SHALL BE PUT INTO PLACE PRIOR TO BEGINNING ANY CONSTRUCTION OR DEMOLITION.
- THE CONTRACTOR SHALL BE RESPONSIBLE FOR THE CONTINUAL MAINTENANCE OF ALL EROSION CONTROL DEVICES THROUGHOUT THE DURATION OF THE PROJECT.
- CONTRACTOR SHALL MEET ALL OF THE STATE OF MASSACHUSETTS D.E.S. AND THE CITY OF FITCHBURG'S WETLAND CROWNINGS REGULATIONS FOR SEDIMENT AND EROSION CONTROL.
- EXCAVATED MATERIAL STOCKPILED ON THE SITE SHALL BE SURROUNDED BY A RING OF UNBROKEN SEDIMENT AND EROSION CONTROL FENCE. THE LIMITS OF ALL GRADING AND DISTURBANCE SHALL BE KEPT TO A MINIMUM WITHIN THE APPROVED AREA OF CONSTRUCTION. ALL AREAS OUTSIDE OF THE LIMIT OF CONTRACT SHALL REMAIN TOTALLY UNDISTURBED UNLESS OTHERWISE APPROVED BY OWNER'S REPRESENTATIVE.
- ALL CATCH BASINS AND DRAIN GRATES WITHIN LIMIT OF CONTRACT SHALL BE PROTECTED WITH FILTER FABRIC BARRIERS THE ENTIRE DURATION OF CONSTRUCTION.
- EROSION CONTROL BARRIERS TO BE INSTALLED AT THE TOE OF SLOPES. SEE GRADING & DRAINAGE PLANS, NOTES, DETAILS AND SPECIFICATIONS.
- ANY AREA OUTSIDE THE PROJECT LIMIT THAT IS DISTURBED SHALL BE RESTORED TO ITS ORIGINAL CONDITION AT NO COST TO THE OWNER.
- THE CONTRACTOR SHALL PROVIDE DUST CONTROL FOR CONSTRUCTION OPERATIONS AS APPROVED BY OWNER.
- ALL POINTS OF CONSTRUCTION EGRESS OR INGRESS SHALL BE MAINTAINED TO PREVENT TRACKING OR FLOWING OF SEDIMENT ONTO PUBLIC/Private ROADS.

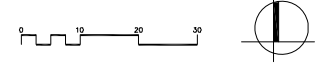

Project
CITY OF FITCHBURG



Spurr
INCORPORATED
85 Devonshire Street, 3rd Floor
Boston, MA 02109
(617) 412-4455 (508) 548-5000
www.spurrcorp.com

Consultant

Revisions:

Rev	Date	Description
1	06.22.16	GRADING REVISIONS
2	05.30.17	AS-BUILT

Scale:

AS BUILT DOCUMENTS

Date:	01.30.2017
Scale:	AS SHOWN
Drawn By:	CB/R
Reviewed By:	ERB
Approved By:	ERB

Drawing Title

SITE PREPARATION & DEMOLITION PLAN

Sheet Number:
L2.01

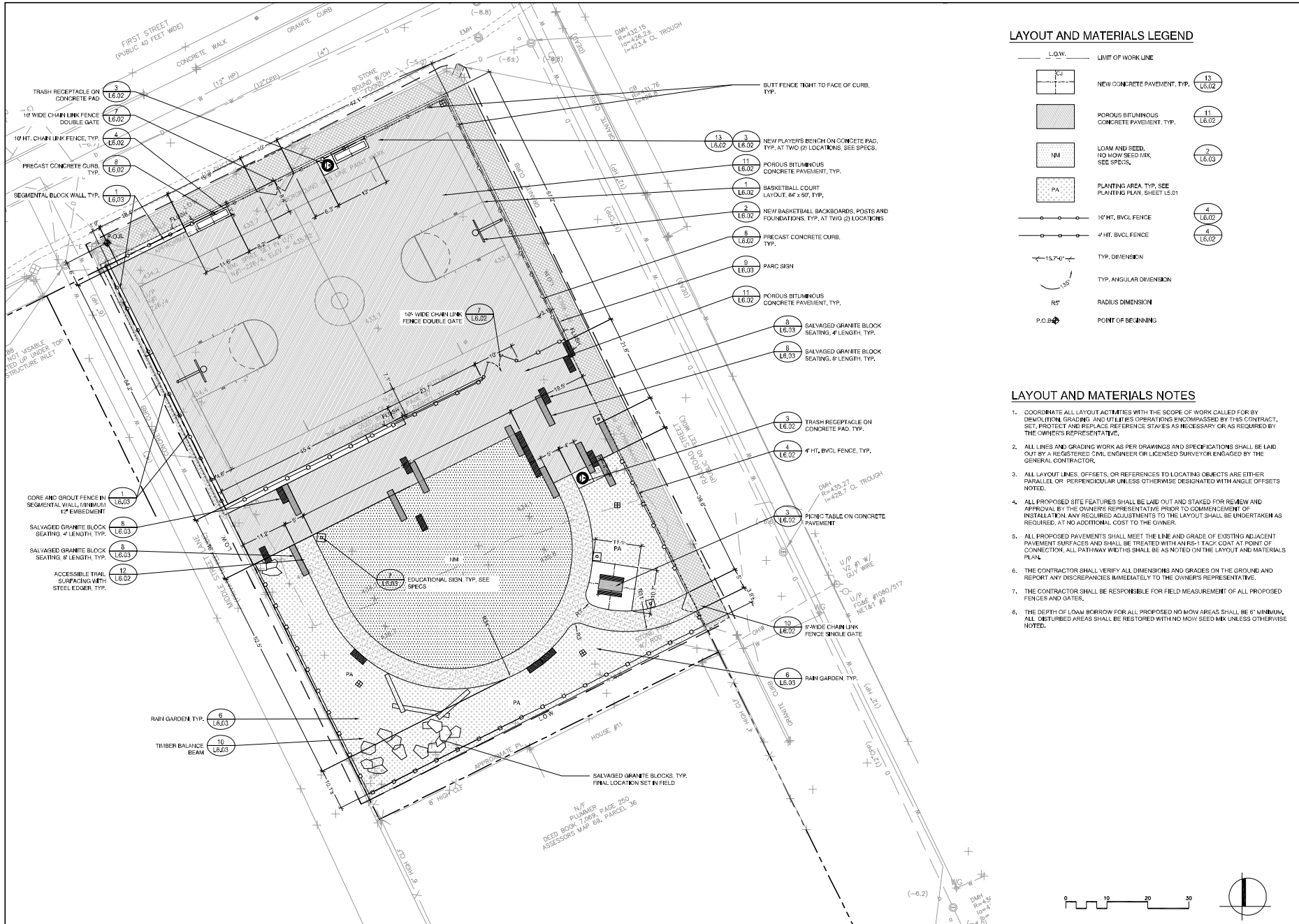

LAYOUT AND MATERIALS LEGEND

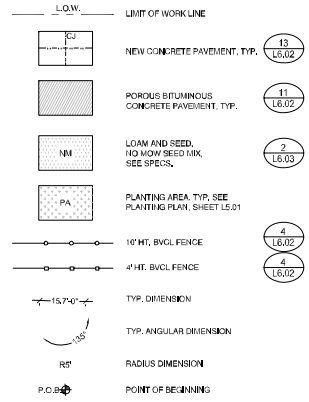

LAYOUT AND MATERIALS NOTES

- COORDINATE ALL LAYOUT ACTIVITIES WITH THE SCOPE OF WORK CALLED FOR BY DEMOLITION, GRADING AND UTILITIES OPERATIONS ENCOMPASSED BY THIS CONTRACT, SET, PROTECT AND REPLACE REFERENCE STAKES AS NECESSARY OR AS REQUIRED BY THE OWNER'S REPRESENTATIVE.
- ALL LINES AND GRADING WORK AS PER DRAWINGS AND SPECIFICATIONS SHALL BE LAID OUT BY A REGISTERED CIVIL ENGINEER OR LICENSED SURVEYOR ENGAGED BY THE GENERAL CONTRACTOR.
- ALL LAYOUT LINES, OFFSETS, OR REFERENCES TO LOCATING OBJECTS ARE EITHER PARALLEL OR PERPENDICULAR UNLESS OTHERWISE DESIGNATED WITH ANGLE OFFSETS NOTED.
- ALL PROPOSED SITE FEATURES SHALL BE LAID OUT AND STAKED FOR REVIEW AND APPROVAL BY THE OWNER'S REPRESENTATIVE PRIOR TO COMMENCEMENT OF INSTALLATION. ANY REQUIRED ADJUSTMENTS TO THE LAYOUT SHALL BE UNDERTAKEN AS REQUIRED, AT NO ADDITIONAL COST TO THE OWNER.
- ALL PROPOSED PAVEMENTS SHALL MEET THE LINE AND GRADE OF EXISTING ADJACENT PAVEMENT SURFACES AND SHALL BE TREATED WITH AN RS-1 TACK COAT AT POINT OF CONNECTION. ALL PATHWAY WIDTHS SHALL BE AS NOTED ON THE LAYOUT AND MATERIALS PLAN.
- THE CONTRACTOR SHALL VERIFY ALL DIMENSIONS AND GRADES ON THE GROUND AND REPORT ANY DISCREPANCIES IMMEDIATELY TO THE OWNER'S REPRESENTATIVE.
- THE CONTRACTOR SHALL BE RESPONSIBLE FOR FIELD MEASUREMENT OF ALL PROPOSED FENCES AND GATES.
- THE DEPTH OF LOAM BORROW FOR ALL PROPOSED NO MOW AREAS SHALL BE 6" MINIMUM. ALL DISTURBED AREAS SHALL BE RESTORED WITH NO MOW SEED MIX UNLESS OTHERWISE NOTED.

Project
CITY OF FITCHBURG

Improvements to
First and Railroad
Street Park

85 Devonshire Street, 3rd Floor
Boston, MA 02109
(617) 412-4455 (508) 548-5000
www.spurr-engineering.com

Consultants

Revisions:

Rev	Date	Description
1	06.22.16	GRADING REVISIONS
2	05.30.17	AS-BUILT

Scale:

AS BUILT DOCUMENTS

Date: 01.30.2017
Scale: AS SHOWN
Drawn By: CBB/R
Reviewed By: ERB
Checked By: ERB
Approved By: ERB

Drawing Title:
LAYOUT & MATERIALS PLAN

Sheet Number:
L3.01

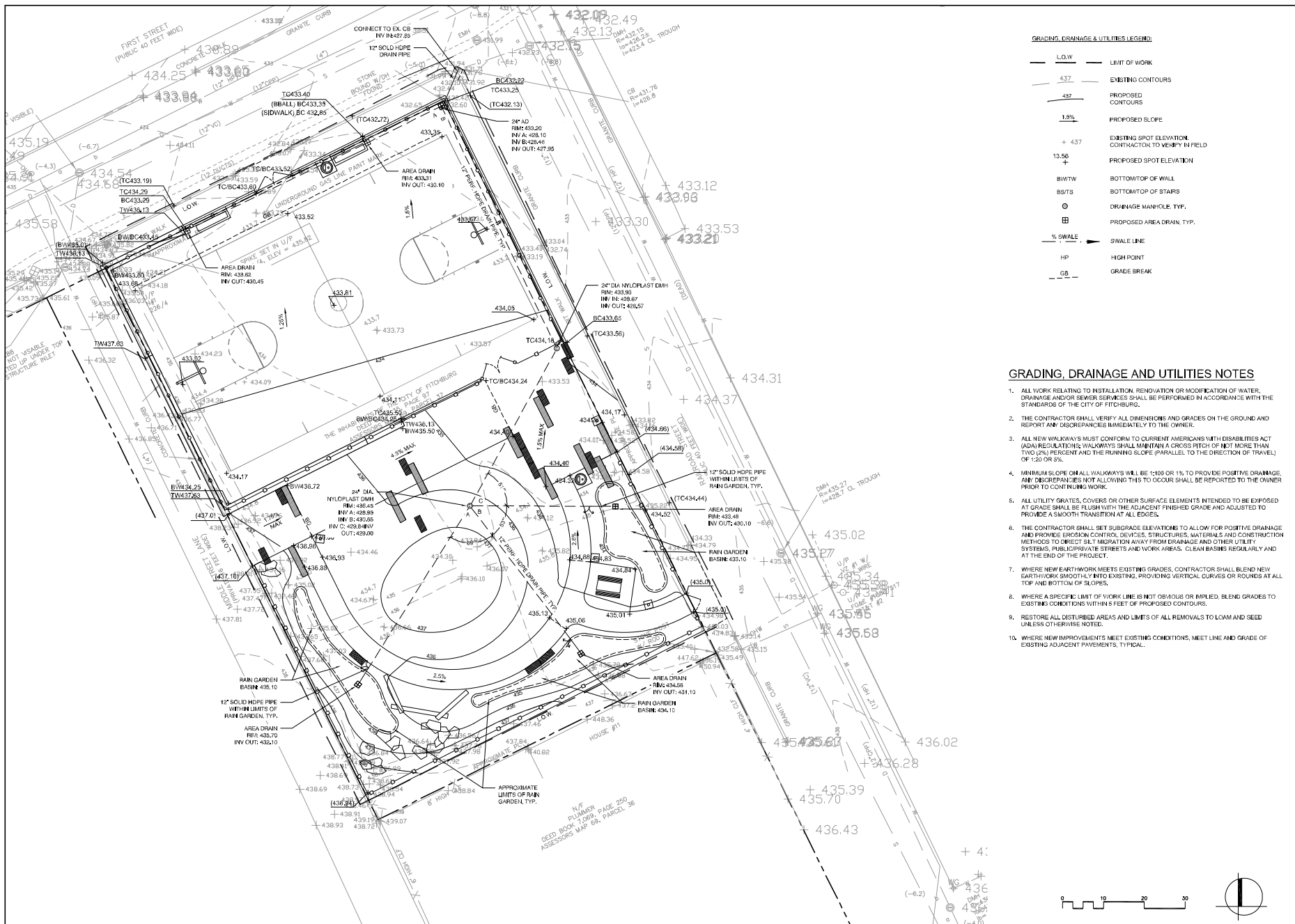

GRADING, DRAINAGE & UTILITIES LEGEND:

- L.O.W. — LIMIT OF WORK
- 437 — EXISTING CONTOURS
- 437 — PROPOSED CONTOURS
- 1.8% — PROPOSED SLOPE
- + 437 — EXISTING SPOT ELEVATION
- 13.56 + — PROPOSED SPOT ELEVATION
- B/W/T/W — BOTTOM/TOP OF WALL
- B/S/T/S — BOTTOM/TOP OF STAIRS
- ⊙ — DRAINAGE MANHOLE, TYP.
- ⊞ — PROPOSED AREA DRAIN, TYP.
- SWALE — SWALE LINE
- HP — HIGH POINT
- GB — GRADE BREAK

GRADING, DRAINAGE AND UTILITIES NOTES

1. ALL WORK RELATING TO INSTALLATION, RENOVATION OR MODIFICATION OF WATER, DRAINAGE AND/OR SEWER SERVICES SHALL BE PERFORMED IN ACCORDANCE WITH THE STANDARDS OF THE CITY OF FITCHBURG.
2. THE CONTRACTOR SHALL VERIFY ALL DIMENSIONS AND GRADES ON THE GROUND AND REPORT ANY DISCREPANCIES IMMEDIATELY TO THE OWNER.
3. ALL NEW WALKWAYS MUST CONFORM TO CURRENT AMERICANS WITH DISABILITIES ACT (ADA) REGULATIONS; WALKWAYS SHALL MAINTAIN A CROSS SLOPE OF NOT MORE THAN TWO (2%) PERCENT AND THE RUNNING SLOPE (PARALLEL TO THE DIRECTION OF TRAVEL) OF 1:20 OR 5%.
4. MINIMUM SLOPE ON ALL WALKWAYS WILL BE 1:100 OR 1% TO PROVIDE POSITIVE DRAINAGE. ANY DISCREPANCIES NOT ALLOWING THIS TO OCCUR SHALL BE REPORTED TO THE OWNER PRIOR TO CONTINUING WORK.
5. ALL UTILITY GRATES, COVERS OR OTHER SURFACE ELEMENTS INTENDED TO BE EXPOSED AT GRADE SHALL BE FLUSH WITH THE ADJACENT FINISHED GRADE AND ADJUSTED TO PROVIDE A SMOOTH TRANSITION AT ALL EDGES.
6. THE CONTRACTOR SHALL SET SUBGRADE ELEVATIONS TO ALLOW FOR POSITIVE DRAINAGE AND PROVIDE EROSION CONTROL, DEVICES, STRUCTURES, MATERIALS AND CONSTRUCTION METHODS TO DIRECT SILT MIGRATION AWAY FROM DRAINAGE AND OTHER UTILITY SYSTEMS, PUBLIC/Private STREETS AND WORK AREAS. CLEAN BASINS REGULARLY AND AT THE END OF THE PROJECT.
7. WHERE NEW EARTHWORK MEETS EXISTING GRADES, CONTRACTOR SHALL BLEND NEW EARTHWORK SMOOTHLY INTO EXISTING, PROVIDING VERTICAL CURVES OR ROUNDS AT ALL TOP AND BOTTOM OF SLOPES.
8. WHERE A SPECIFIC LIMIT OF WORK LINE IS NOT OBVIOUS OR IMPLIED, BLEND GRADES TO EXISTING CONDITIONS WITHIN 5 FEET OF PROPOSED CONTOURS.
9. RESTORE ALL DISTURBED AREAS AND LIMITS OF ALL REMOVALS TO LOAM AND SEED UNLESS OTHERWISE NOTED.
10. WHERE NEW IMPROVEMENTS MEET EXISTING CONDITIONS, MEET LINE AND GRADE OF EXISTING ADJACENT PAVEMENTS, TYPICAL.

Project
CITY OF FITCHBURG



Improvements to
First and Railroad
Street Park



85 Devonshire Street, 3rd Floor
Boston, MA 02109
(617) 412-4451 (508) 548-5000
www.spurr.com

Consultant

Revisions:

Rev	Date	Description
1	06.22.16	GRADING REVISIONS
2	05.30.17	AS-BUILT

Scale:

AS BUILT DOCUMENTS

Date:	01.30.2017
Scale:	AS SHOWN
Drawn By:	CB/BR
Reviewed By:	ERB
Checked By:	ERB
Approved By:	ERB

Drawing Title:
GRADING, DRAINAGE & UTILITY PLAN

Sheet Number:
L4.01

- BURY THE TOP END OF EXCELSIOR MATTING STRIPS MINIMUM 6 INCHES.
- TAMP THE TRENCH FULL OF SOIL, SECURE WITH ROW OF STAPLES, 6 INCH SPACING 4 INCHES DOWN FROM THE TRENCH.
- OVERLAP: BURY UPPER END OF LOWER STRIP AS IN 'A' AND 'B'. OVERLAP END OF TOP STRIP 4 INCHES AND STAPLE.
- EROSION STOP-FOLD EDGE OF EXCELSIOR MATTING BURIED IN SILT TRENCH AND TAMPED; DOUBLE ROW OF STAPLES.

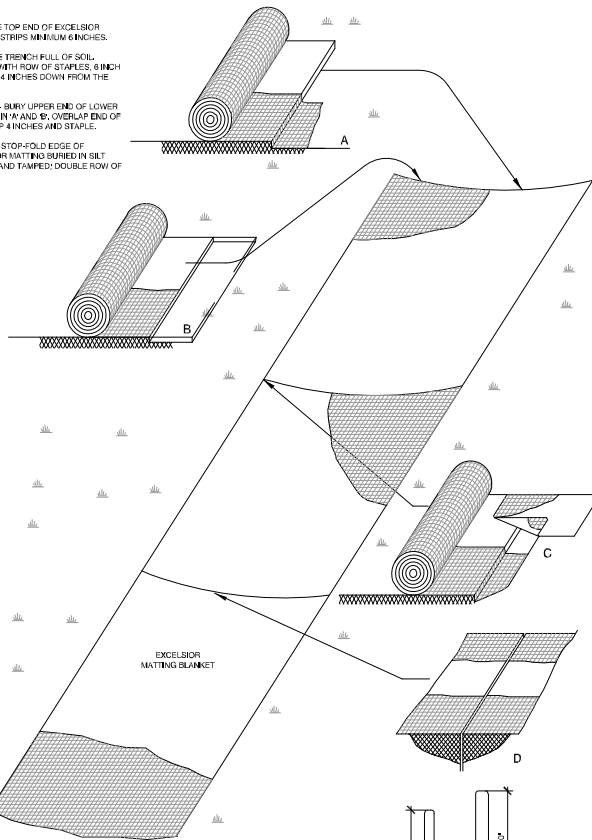

NOTE:
1. JUTE NETTING TO BE USED ON ALL SLOPES GREATER THAN 4H:1V AS INDICATED ON GRADING PLANS

4 INCH OVERLAP OF EXCELSIOR MATTING STRIPS WHERE TWO OR MORE STRIPS WIDTH ARE REQUIRED. STAPLES ON 1'-0" CENTERS.
STAPLE OUTSIDE EDGE ON 2'-0" CENTERS.

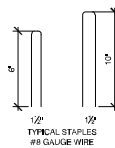

1 EROSION CONTROL BLANKET
NOT TO SCALE

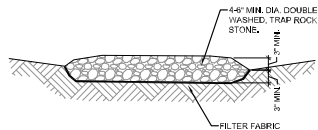

- NOTE:
- PROVIDE DRAINAGE AWAY FROM STABILIZED CONSTRUCTION ENTRANCE TO ACCEPTABLE SEDIMENT TRAPPING DEVICE.
 - CONTRACTOR TO PROVIDE A WATER SOURCE FOR A WASH STATION FOR ALL VEHICLES LEAVING THE SITE.
 - PROVIDE 20' MADE BY 50' LONG ENTRANCE PAD, SEE PLANS FOR LOCATION.

2 STABILIZED STONE CONSTRUCTION ENTRANCE PAD
NOT TO SCALE

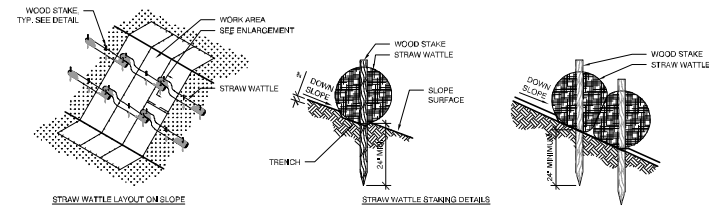

3 EROSION CONTROLS
NOT TO SCALE

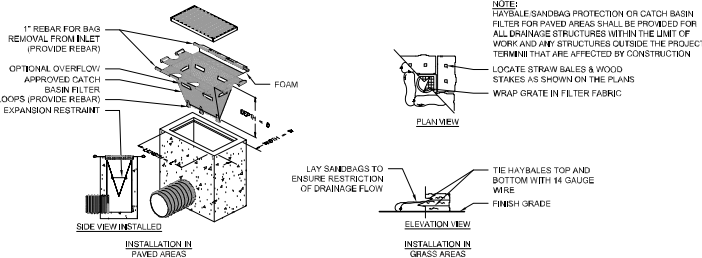

4 INLET SEDIMENT CONTROL
NOT TO SCALE

- NOTES:
- 24" MIN SUMP IS REQUIRED ON AREA DRAINS ONLY.
 - GRATES AND/OR SOLID COVERS SHALL BE A MINIMUM 24" ROUND AT THE LOCATIONS INDICATED ON THE CONSTRUCTION PLAN.

5 DRAINAGE PIPE TRENCH
SCALE: N.T.S.

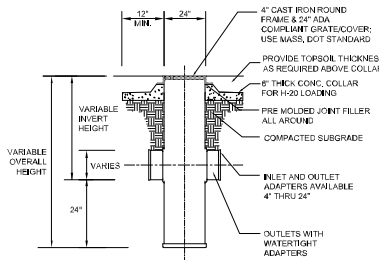

6 DRAINAGE PIPE TRENCH
SCALE: N.T.S.

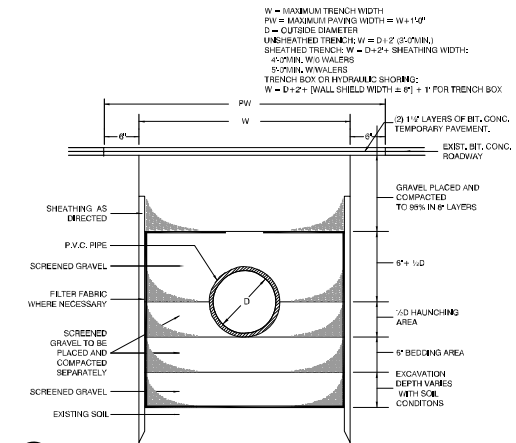

Rev	Date	Description
1	03/22/16	GRADING REVISIONS
2	05/26/17	AS-BUILT

Date:	05/30/2017
Scale:	AS SHOWN
Drawn By:	CSBR
Reviewed By:	ERB
Checked By:	
Approved By:	

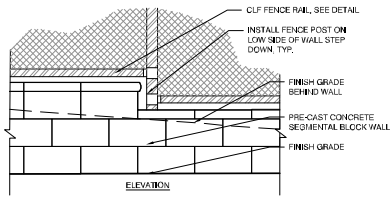

1 SEGMENTAL BLOCK WALL
NOT TO SCALE

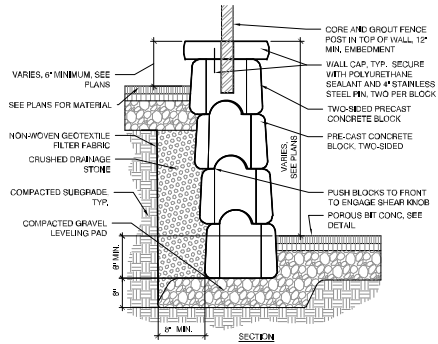

2 LOAM AND SEED
NOT TO SCALE

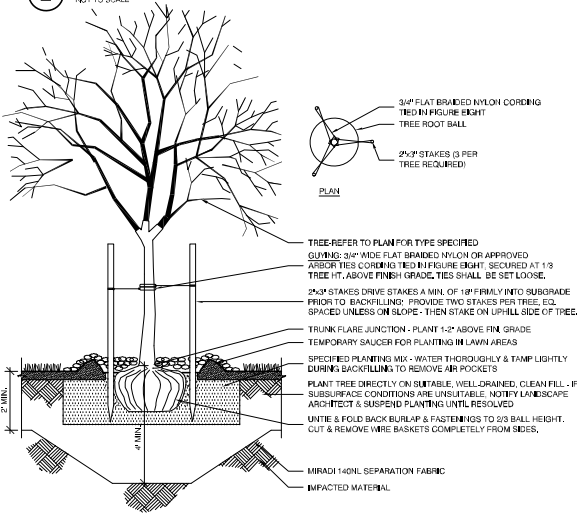
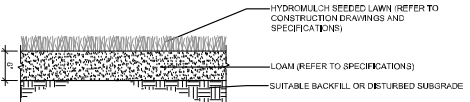

3 DECIDUOUS TREE PLANTING
NOT TO SCALE

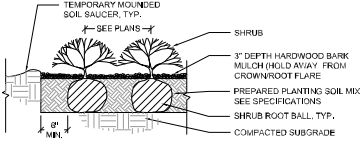

4 SHRUB PLANTING
NOT TO SCALE

NOTES:
1. ALL MULCH MUST BE DARK IN COLOR, PROVIDE SAMPLE PRIOR TO INSTALLATION TO BE APPROVED BY OWNER'S REPRESENTATIVE.

GROUNDCOVER SPACING TABLE

PLANT SPACING 'A'	PLANT SPACING 'B'	PLANTS	AREA UNIT
6\"/>			

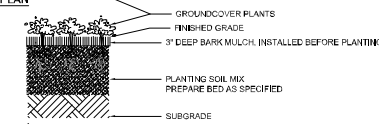

SECTION

NOTES:
1. ALL GROUNDCOVER TO BE PLANTED IN TRIANGULAR PATTERN. SEE DETAIL PLAN AND GROUNDCOVER SPACING TABLE.
2. JUTE EROSION CONTROL MAT TO BE USED ON ALL SLOPES GREATER THAN 3:1

5 GROUNDCOVER PLANTING
NOT TO SCALE

NOTES:
1. REFER TO PLANTING PLAN FOR PLANT TYPE AND SPACING.

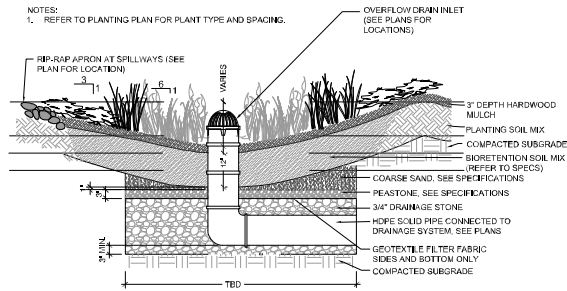

6 RAIN GARDEN DETAIL
NOT TO SCALE

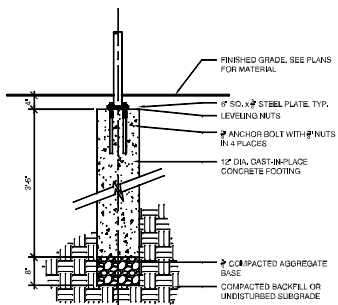

7 SIGN POST FOOTING
NOT TO SCALE

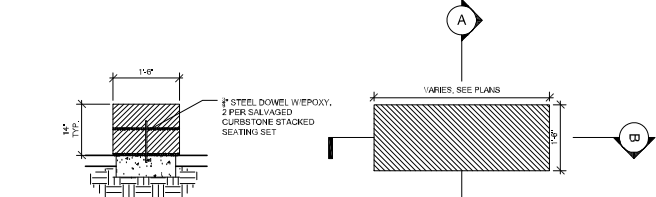

8 SALVAGED GRANITE BLOCK SEATING
NOT TO SCALE

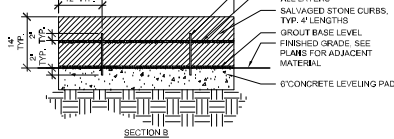

9 PARC GRANT SIGNAGE
NOT TO SCALE

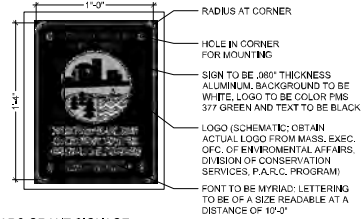

10 TIMBER BALANCE BEAM
NOT TO SCALE

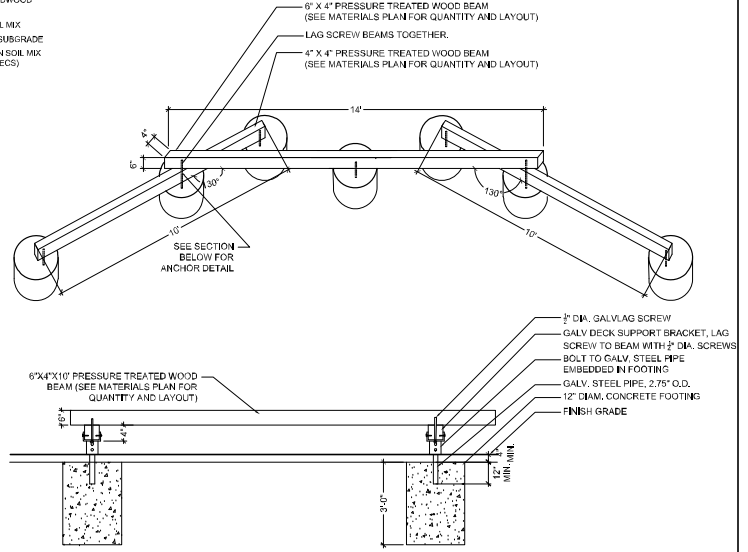

Rev	Date	Description
1	05/22/16	GRADING REVISIONS
2	05/26/17	AS-BUILT

Attachment 5

Montachusett Regional Vocational Technical School
Montachusett Opportunity Council
City of Fitchburg



Rain Garden Workshop Basis of Design

April 19, 2016

Background

The Montachusett Opportunity Council (MOC) has received grant funding from the United States Environmental Protection Agency (EPA) to implement various stormwater-related programs and projects within the City of Fitchburg. Under that grant, MOC is conducting a Rain Garden Workshop with students from the Montachusett Regional Vocational Technical School (Monty Tech) to educate and inform young people about the impacts of stormwater on the environment and the ways rain gardens can be used to mitigate these impacts.

The Rain Garden Workshop will include a classroom presentation by Ed Himlan of the Massachusetts Watershed Coalition followed by a field demonstration in which students construct a rain garden. The City of Fitchburg has performed the design of the rain garden to be constructed by the students and MOC on April 27, 2016. The following sections describe the design process for the rain garden, including site selection, sizing, and plant selection.

Site Selection

On March 29, Kenneth Pearson, an Environmental Science teacher at Monty Tech, and Nick Erickson, a civil engineer with the City of Fitchburg, conducted a site walk of the Monty Tech campus to evaluate potential locations for the installation of a rain garden. The Monty Tech campus itself consists of a very large school building, several large parking lots, and several athletic fields. Topography within the parking lots in front of the school is sloped away from the school towards a long, linear, grassed depression between the parking lots and Route 2A. Several catch basins located within paved areas and within the grassed area convey stormwater flows into a collection system, with an outfall likely discharging to Snows Millpond across Route 2A. Topography within the parking lots in the rear of the building is sloped away from the school towards catch basins in the center of the parking lots. There is a large hill behind the school, and runoff from this hill likely flows into the school parking lot catch basins, as evidenced by some observed erosion.

Characteristics for an ideal rain garden site include the following:

- Grassed, dirt, or otherwise minimally vegetated area where a small depression can be excavated and vegetation planted;
- Contributing impervious area sloped towards the area without impeding landscape or hardscape features (curbing, sidewalks, large trees, etc.) that would intercept stormwater runoff;
- Ability of the site to drain flows from larger storms without creating flooding on- or off-site.

The site walk identified several locations that matched one or more of these criteria; however one site matched them all. Refer to Figure 1 below for the site location and to Figures 2-5 for photographs of the site. Note the proposed site contains the following key elements:

- Site consists of a grassy area surrounding a sign; the rain garden can be designed to surround the sign and will be both functional and visually appealing
- Large paved parking lot area sloped towards site to provide runoff, evidenced by ponding of water following the previous day's rainstorm and sedimentation along the edge of pavement;
- Adjacent catch basin that will serve to drain overflow from the rain garden during larger precipitation events.

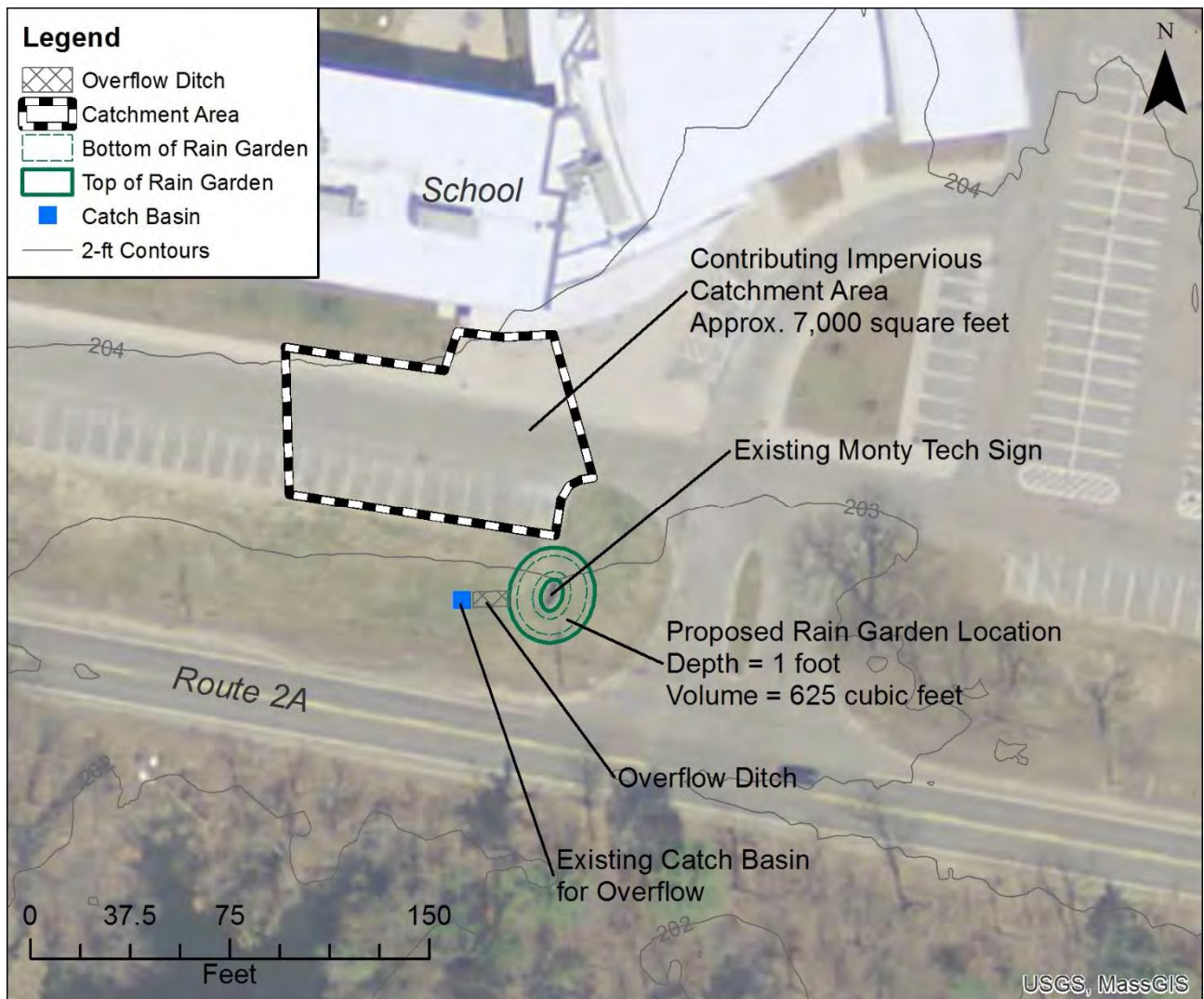

Figure 1. Location of Proposed Rain Garden



Figure 2. Rain Garden Site



Figure 3. Ponding and Sedimentation near Site



Figure 4. Rain Garden Site



Figure 5. Contributing Impervious Area Sloped towards Site

Sizing

When sizing a rain garden, several factors must be considered, including:

- size of contributing impervious area
- depth of runoff it must treat
- space available

In this case, the contributing impervious area is approximately 7,000 square feet. In accordance with the Massachusetts Stormwater Standards, the depth of runoff treated by this BMP should be a minimum of 1-inch. Multiplying the 7,000 square feet of contributing area by the 1-inch depth of runoff yields a volume of roughly 585 cubic feet of runoff that the proposed rain garden must be able to hold.

There is a significant amount of space around the existing Monty Tech sign in which to construct a rain garden that will blend in with the existing landscaping. A rain garden constructed in the location shown in Figure 1 with a bottom surface area of 415.4 square feet, a top surface area of 831.8 square feet, and a

depth of one foot will provide approximately 624.5 cubic feet of storage. Refer to Figure 6 below for profile and cross section schematics.

The adjacent catch basin will provide an outlet to drain excess stormwater from the rain garden. A small ditch between the rain garden and the edge of the swale will convey excess flows. The ditch will be 4 feet wide and 4 inches deep and lined with 3-inch rip rap stone. **The total volume of 3-inch rip rap stone needed will be approximately 0.3 cubic yards.**

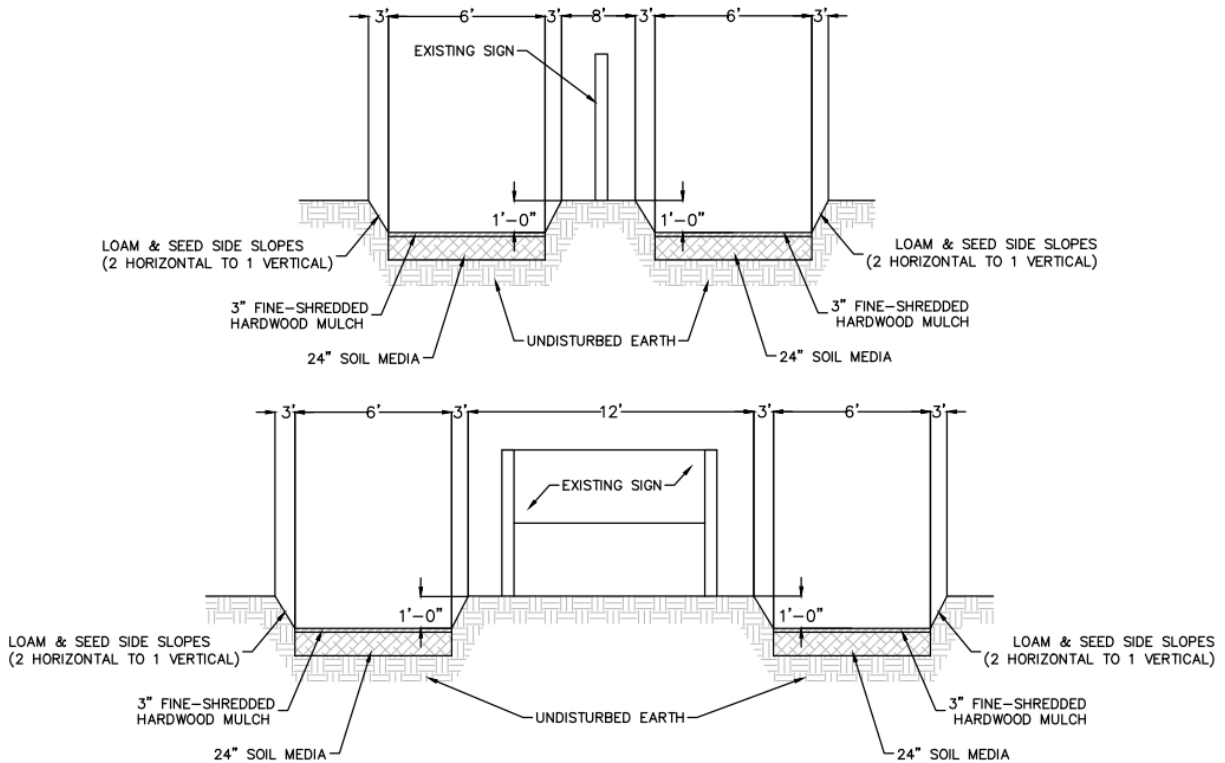

Figure 6. Rain Garden Section and Profile

Soil Media

The soil media for the rain garden should be a mixture of sand, compost, and soil:

- 40% sand (gravelly sand that meets ASTM D 422)

Table 1. Sand Gradation for Soil Media

Sieve Size	Percent Passing
2-inch	100
¾-inch	70-100
¼-inch	50-80
#40	15-40
#200	0-3

- 20-30% topsoil (sandy loam, loamy sand, or loam texture; 1.5-3% organic content; max. 500 ppm soluble salts)

- 30-40% compost (processed from yard waste in accordance with MassDEP guidelines)

The soil mix should be uniform, free of stones, stumps, roots, or similar objects larger than 2-inches. Clay content should not exceed 5%. Soil pH should be between 5.5 and 6.5. **The total volume of soil media needed will be approximately 35 cubic yards.**

On top of the soil media will be a 3-inch layer of fine-shredded hardwood mulch. **The total volume of mulch needed will be approximately 6 cubic yards.**

Plantings

Please refer to Table 1 below for a list of plantings and Figure 7 for the planting plan.

Table 2. Plantings for Proposed Rain Garden

Abb.	Quant.	Common Name	Botanical Name	Size	Notes
HQ	5	Oak-leaf Hydrangea	Hydrangea Quercifolia	6'-8' HT	Space 4' O.C.
IV	4	Winterberry Holly	Ilex Verticillata	3'-12' HT	Space 6' O.C.
IVH	10	Sweetspire	Itea Virginica 'Henry's Gamet'	3'-4' HT	Space 4' O.C.
RA	7	Fragrant Sumac	Rhus Aromatica 'Gro Low'	1.5'-2' HT	Space 4' O.C.
PV	17	Switch Grass	Panicum Virgatum	4-5' HT	
LC	-	Birdsfoot Trefoil	Lotus Corniculatus	2'-3' HT	Broadcast

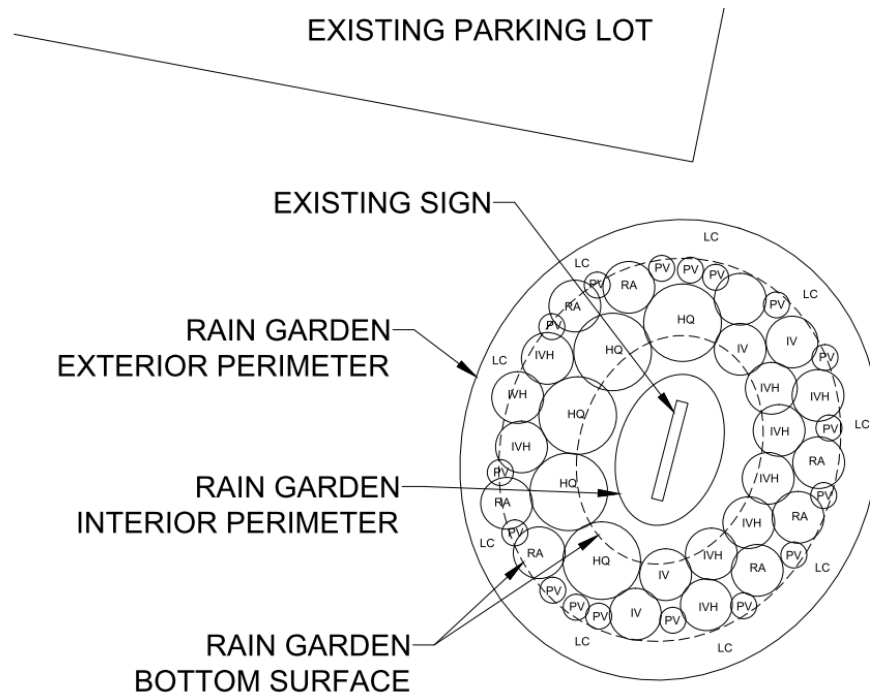

Figure 7. Planting Plan for Proposed Rain Garden

Attachment 6

Central Massachusetts Regional Stormwater Coalition Coalition Activities in Year 15 (April 1, 2017-March 31, 2018)

Introduction

The Central Massachusetts Regional Stormwater Coalition (CMRSWC) is an MS4 resource for all 30 member communities. CMRSWC has three standing sub-committees to allow members to focus efforts on specific issues important to the Coalition. These sub-committees are:

- **Education Sub-Committee:** responsible for developing and promoting outreach and educational materials required by the MS4 permit. The Education sub-committee is also responsible for planning and scheduling the Annual Meeting, educational workshops, and other forums for discussion of MS4 topics. The committee is CMRSWC's primary liaison to professional organizations and university partnerships.
- **Technical Sub-Committee:** responsible for managing Coalition's website and shared equipment resources; advising members on relevant technical issues including GIS system maintenance and upgrades.
- **Legislative Sub-Committee:** serves as the liaison to the Massachusetts Statewide Stormwater Collaborative; responsible for tracking MS4 related legislation and regulations and keeping the legislature and regulatory agencies informed of the concerns of member communities.

The CMRSWC Steering Committee held four meetings during this 12 month reporting cycle. The CMRSWC Annual Meeting was held on November 15, 2017 in Worcester. Members of CMRSWC also attended and actively participated in the Massachusetts Statewide Municipal Stormwater Coalition meetings.

MS4 Workshops and Technical Training (Minimum Control Measures 3, 4, 5, and 6)

Best Management Practices Technical Tour

On October 25, 2017, CMRSWC sponsored a technical tour and workshop for DPWs, Highway, and other staff in member communities responsible for the operations and maintenance of local roads, drainage, sidewalks, parking lots, and other public infrastructure. The tour was led by a team from Fuss & O'Neill and took attendees from 14 communities on a "road trip" to visit sites at Dennison Lubricants (Worcester), Tufts Veterinary School (North Grafton), and several Mass DCR sites. At each site, participants had the opportunity to learn about the BMPs in use at the site from a variety of staff from DCR and Mass DOT, as well as engineers and project owners. A lunch program offered additional opportunities to discuss stormwater management techniques. Handouts, presentation materials, and video footage of the tour are being offered to CMRSWC members through the website.

Videos and Templates (Minimum Control Measures 1, 3, 4, 5, 6)

As a follow-up to the Best Management Practices Technical Tour, 12 new CMRSWC videos were produced that feature the various BMPs visited on the tour, presentations from the day, and additional detailed footage recorded at the BMP sites after the event.

Department of Conservation and Recreation Education and Outreach Materials (Minimum Control Measures 1 and 2)

As part of the Stormwater BMP Technical Tour, Kelley Freda from the Department of Conservation and Resources presented participants with stormwater education and outreach materials available from DCR. She distributed a packet of various brochures targeting a diverse audience. These materials are available from the DCR website www.mass.gov/dcr/watersupply

Worcester Polytechnic Institute Water Resource Outreach Center (Minimum Control Measures 1 and 2)

Worcester Polytechnic Institute's (WPI) Massachusetts Water Resource Outreach Center (WROC) is dedicated to assisting Central and Eastern Massachusetts municipalities and watershed associations with their water resource needs through student project collaboration. CMRSWC has been working with the WPI-WROC and MassDEP on Interactive Qualifying Projects (IQPs) since 2012.

The CMRSWC and MassDEP sponsored a 2017 WPI-WROC project called "Stormwater Management Educational Materials for Central Massachusetts Municipalities." Municipalities are required to distribute educational materials on stormwater issues to comply with the MS4 permit; "the ultimate objective being to increase knowledge and change behavior of the public so that pollutants in stormwater are reduced." The project team used public surveys and questionnaires to assess the public's understanding of stormwater and stormwater runoff. The results showed that most people do not understand what stormwater is, how it gets into our waterbodies and the impacts it has on water quality and public health. Focusing on increasing awareness of the importance of protecting our water among our elementary school student population, the WPI students developed a stormwater toolkit featuring an activity book and stickers for children. The activity book includes opportunities for parents to participate and ask questions.

Building on the previous work for educational materials, the 2018 student team worked with stormwater experts at MassDEP, MA Department of Education representatives and school teachers from Shrewsbury and Holden to develop a 5th grade watershed curriculum that meets the new Massachusetts Next Generation science standards. Components of the curriculum include the water cycle, watersheds, stormwater runoff and other environmental features that demonstrate to children how runoff and contaminants affect water quality. The students will be presenting their findings on May 1, 2018 at 4:00 p.m. at the MassDEP Central Regional Office in Worcester.

More information is available at: <http://wp.wpi.edu/wroc/>

EnviroScape Nonpoint Source Pollution Model (Minimum Control Measures 1 and 2)

The CMRSWC owns two 3D EnviroScape® Watershed/Nonpoint Source models which are available for use by our members. These models provide a hands-on, interactive demonstration of the sources and effects of water pollution and ways to prevent pollution. The CMRSWC sponsored a booth at the EcoTarium's Earth Day Celebration in April using the model to teach about stormwater education. Several member communities including Holden, Charlton, Framingham, Hopkinton, Lunenburg, Palmer, Shrewsbury, Auburn, & Dudley have used the EnviroScape model for presentations at Earth Day festivals, school programs, scouting events, and public works open houses.

Member Needs Survey

In March 2018, CMRSWC contracted with Fuss & O’Neill to develop a technical needs survey that measured the concerns of member communities with respect to compliance with the updated MS4 General Permit for Stormwater Discharges (which is currently stayed pending judicial review). The survey served as a follow-up to the first coalition member survey in the fall of 2016 and asked members to rank certain programs/tasks that CMRSWC could support to assist members in complying with the MS4 Permit. The survey also requested that respondents identify the CMRSWC tools, resources, and events that they made use of during 2017 or provide feedback on why they chose not to take advantage of such tools or events.

Coalition members ranked their needs as follows:

1. Maintain the CMRSWC Website with Available Tools and Templates
2. Provide Written IDDE Program Template and Training
3. Provide NOI/SWMP Template and Training

Coalition members ranked their compliance concerns as follows:

1. Preparation of NOI and SWMP
2. Performing Outfall Inspections
3. Performing Outfall Inventory Ranking
4. Meeting TMDL Requirements
5. Developing Written Catchment Investigation Procedures
6. Designing and Constructing BMP Retrofits
7. Designing and Maintaining SWPPPs
8. Identifying and Removing Illicit/Illegal Discharges
9. Developing a Written IDDE Program
10. Mapping the Storm Sewer System

Statewide Stormwater Coalition Grant Award

CMRSWC announced at its January 8th Steering Committee Meeting a \$200,000 grant from the State to the Statewide Stormwater Coalition to develop and implement a statewide stormwater education and outreach campaign. The project will provide stormwater education materials to communities across the state, including CMRSWC member communities. The funds, issued through the Commonwealth’s Fiscal Year 2018 “MS4 Municipal Assistance Grant Program,” recognize the important work of stormwater coalitions and regionalized stormwater management. Materials will be made available in July 2018.

Conclusion

Working as a group, CMRSWC collectively protects regional water resources while assisting communities with meeting requirements of the MS4 permit in an efficient and cost-effective manner. Member communities continue to benefit from the use of CMRSWC tools, resources, and events to continue to implement their MS4 program with local staff and resources.

Attachment 7

Local Organizations

To learn more about stormwater, please contact these local organizations:

Nashua River Watershed

Association

592 Main St., Groton MA

(978) 448-0299

www.nashuariverwatershed.org

Mass. Audubon @ Broad

Meadow Brook Sanctuary

414 Massasoit Rd., Worcester MA

(508) 753-6087

www.massaudubon.org

Mass. Audubon @ Wachusett

Meadow Sanctuary

113 Goodnow Rd., Princeton MA

(978) 464-2712

www.massaudubon.org

This brochure was created by a team of students from Worcester Polytechnic Institute's Water Resource Outreach Center in collaboration with the Fitchburg Department of Public Works and Public School System.



WPI Team:

Sean Burke

Mike Cooke

Tom Kouttron

Cielo Sharkus

If you have any questions regarding our project, please email fitchburg18@wpi.edu.

Only Rain Down the Drain!

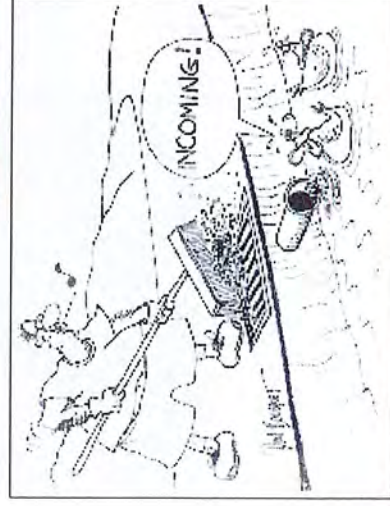

What is Stormwater?

- Water from rain or snow that is not absorbed into the ground.
- This water flows across lawns, sidewalks, and streets until it reaches...



A **STORM DRAIN** and enters into a maze of underground pipes.

Why Should You Care?

- Stormwater picks up all of the pollutants found on lawns, sidewalks, and streets!

Stormwater Myth:

Stormwater is cleaned at a sewage treatment plant before it flows into rivers and lakes.

FALSE!

Stormwater systems are separate from sewer systems, and do NOT go to a treatment plant.

- The result is stormwater and its pollutants flow straight into the Nashua River every day it rains!

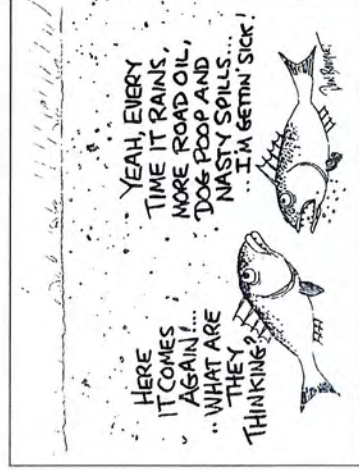

What Can You Do?

There are many ways you can keep stormwater clean:

#1: Only Rain Down the Drain

Storm drains dump into our environment. So, never dump any trash, oils, grass clippings, or chemicals down a storm drain.

#2: Pick Up The Poo

Animal waste contain bacteria that pollute water. Always pick up after your pet using compostable bags and dispose of in trash.

#3: Go Natural

Fertilizers contain harmful phosphorous and nitrogen which wash into ecosystems when it rains. Use natural manures and compost instead!

