



REGION 6
DALLAS, TX 75270

April 7, 2026

Mark Bollinger
Manager
Carlsbad Field Office
4021 National Parks Highway
Carlsbad, New Mexico 88220

RE: The United States Environmental Protection Agency Region 6 Modification Approval of Storage and Disposal of Non-liquid Polychlorinated Biphenyls (PCBs) Contaminated With Transuranic Waste (PCB/TRU) and PCB/TRU Waste Mixed with Hazardous Waste at the Waste Isolation Pilot Plant (WIPP) located at Carlsbad, New Mexico; EPA ID No. NM4890139088

Dear Mr. Bollinger:

This letter and the enclosed Conditions of Approval grant a modification approval to WIPP to dispose of and store non-liquid PCB waste. A Public Notice was published in the Carlsbad Current-Argus newspaper announcing the proposed modification approval, which opened a 45-day comment period, during which requests could be made for a Public Hearing. No comments were received during the comment period, which closed on April 5, 2026.

Violation of 40 CFR Part 761, or any of the enclosed Conditions of Approval, may subject WIPP to enforcement action under the Toxic Substances Control Act (TSCA) and/or other applicable laws and regulations. Such action could result in a termination, revocation, or modification of the approval. This modification approval becomes effective on the date of this letter and expires at midnight on the same day and month, five years after the current Reauthorization Approval.

If you have questions, please contact Harry Shah at (214) 665-6457.

Sincerely,

ROBERT

SNOWBARGER

Robby Snowbarger

Acting Director – Land, Chemicals &

Redevelopment Division (LCRD)

U.S. EPA Region 6

Digitally signed by ROBERT
SNOWBARGER

Date: 2026.04.07 09:23:46
-05'00'

Waste Isolation Pilot Plant (WIPP) Storage and Disposal Approval and Supporting Documents Contents:

- I. LOCATION OFFACILITY.....2
- II. PCB WASTE AND DISPOSAL UNITS AUTHORIZED2
- III. PCB/TRU WASTESTORAGE.....3
- IV. PCB/TRU DISPOSAL REQUIREMENTS.....5
- V. CLOSURE AND POST-CLOSURE CARE.....6
- VI. STANDARD APPROVAL CONDITIONS.....7
- APPENDIX 1 - MAP, REPOSITORY HORIZON AND UNDERGROUND WASTE TRANSPORT ROUTES 12
- APPENDIX 2 - CLOSURE PLAN (REFERENCED FROM ATTACHMENT G IN HWFP)..... 13
- APPENDIX 3 – TRAINING PLAN (REFERENCED FROM ATTACHMENT F IN HWFP)..... 322
- APPENDIX 4 – CONTINGENCY PLAN (REFERENCED FROM ATTACHMENT D IN HWFP) 337

**DISPOSAL OF PCB/TRU AND PCB/TRU MIXED WASTE
AT THE
U.S. DEPARTMENT OF ENERGY (DOE)
WASTE ISOLATION PILOT PLANT (WIPP)
CARLSBAD, NEW MEXICO**

CONDITIONS OF APPROVAL

The disposal of transuranic waste by the DOE is congressionally mandated in Public Law 102-579 (as amended by the National Defense Authorization Act for Fiscal Year 1997, Public Law 104-201, referred to as the WIPP Land Withdrawal Act [LWA]). Portions of the transuranic waste inventory contain hazardous waste constituents regulated in 40 CFR Parts 260 through 279, and/or polychlorinated biphenyls (PCBs) and PCB Items regulated in 40 CFR Part 761. The following conditions of approval address the safe disposal of transuranic PCB and PCB Items at the WIPP.

The terms and abbreviations in these conditions are in accordance with those defined in 40 CFR § 761.3 unless otherwise noted. The term "Facility" hereinafter refers to the Waste Isolation Pilot Plant (WIPP), Carlsbad, New Mexico. The term "owner" refers to the DOE, and the term "operator" refers to DOE and Salado Isolation Mining Contractors LLC. The DOE owns the WIPP and is responsible for the development and day-to-day management of the WIPP facility.

I. LOCATION OFFACILITY

The Facility is located approximately 26 miles southeast of Carlsbad, New Mexico in Eddy County. The geographic coordinates are: 32.3697706, -103.7913501

II. PCB WASTE AND DISPOSAL UNITS AUTHORIZED

A. PCB WASTE AUTHORIZED

1. PCB contaminated transuranic (PCB/TRU), and PCB contaminated transuranic waste mixed with a hazardous waste (PCB/TRU mixed waste) including PCB remediation waste, PCB Articles, and PCB bulk product waste may be stored and disposed at this Facility. The terms "PCB/TRU" and "PCB/TRU mixed waste" are terms used by the Facility. For the purpose of this approval, PCB/TRU and PCB/TRU mixed waste shall be considered a "PCB Item(s)" in accordance with 40 CFR § 761.3.
2. The Facility term "TRU waste" means waste containing more than 100 nanocuries of alpha-emitting transuranic isotopes per gram of waste, with half-lives greater than 20 years, except for (A) high-level radioactive waste; (B) waste that the DOE Secretary has determined, with the concurrence of the EPA Administrator, does not need the degree of isolation required by the disposal regulations; or (C) waste that the Nuclear Regulatory Commission (NRC) has approved for disposal on a case-by-case basis in accordance with 10 CFR Part 61.
3. The Facility term "TRU mixed waste" means TRU waste that is also a hazardous waste as defined by the Hazardous Waste Act and 20 New Mexico Administrative Code (NMAC) 20.4.1.200 (incorporating 40 CFR § 261.3).
4. The term "PCB/TRU waste" shall hereinafter refer to both PCB/TRU and

PCB/TRU mixed waste.

5. The term contact handled (CH) transuranic waste means transuranic waste with a surface dose rate not greater than 200 millirem per hour.
6. The term remote handled (RH) transuranic waste means transuranic waste with a surface dose rate of 200 millirem per hour or greater.
7. The disposal of free-flowing PCB liquids is prohibited at this Facility except those incidental liquids, such as, but not limited to, rainwater, groundwater, condensate, leachate, load separation and dust control liquid are allowed in PCB/TRU and PCB/TRU mixed bulk product waste containers up to one (1) percent of the container volume.
8. No ignitable waste as defined by 40 CFR § 261.21 may be received at this Facility.

B. PCB DISPOSAL UNITS AUTHORIZED

Disposal Panels 2 through 12 are authorized for disposal of PCB/TRU waste as seen in the WIPP underground map in Appendix 1.

C. AUTHORIZATION TO OPERATE ADDITIONAL DISPOSAL UNITS

For a new Panel, the owner/operator may not commence disposal until the Facility has notified, in writing, the EPA Region 6 PCB Coordinator and received a written approval from EPA authorizing the new Panel for PCB disposal. The notification must include a description and a map of the new Panel. The description must include anticipated depth, length, and width of the new Panel and how it will be operated.

D. EXPANSION IN SIZE OR CAPACITY OF AUTHORIZED DISPOSAL UNITS

Any existing Facility modification or expansion in capacity requires notification and response from EPA according to the procedures outlined in II.C. of these conditions.

III. PCB/TRU WASTE STORAGE

A. AUTHORIZED STORAGE AREAS

PCB/TRU waste storage is limited to the following areas:

1. The Parking Area Container Storage Unit consisting of a 137,050 square foot asphalt and concrete surface providing storage space for loaded Nuclear Regulatory Commission (NRC) Type B Packages with up to 8,863 cubic feet of waste, and
2. The Waste Handling Building (WHB) Container Storage Unit consisting of 32,307 square feet of storage area for PCB/CH TRU waste management and provides a storage capacity of up to 6,466.3 cubic feet of PCB/CH TRU waste. The Waste Handling Building (WHB) Container Storage Unit also includes 17,403 square feet of storage area for the PCB/RH TRU waste management and provides a storage capacity of up to 387.7 cubic feet of PCB/RH TRU waste.

B. AUTHORIZATION TO OPERATE ADDITIONAL STORAGE AREAS

For a new PCB/TRU storage area, the owner/operator may not commence storage of PCBs until the Facility has notified, in writing, the EPA Region 6 PCB Coordinator and received a written approval from EPA authorizing the new storage area. The notification must include a description and storage capacity of the proposed new area.

C. EXPANSION IN SIZE OR CAPACITY OF AUTHORIZED STORAGE AREAS

Any existing storage area modification or expansion in capacity over and above what is authorized in this approval requires notification and response from EPA according to the procedures outlined in III.B. of these conditions.

D. GENERAL PCB/TRU STORAGE REQUIREMENTS

1. Storage of PCB/TRU waste must comply with 40 CFR 761.65(c)(5) and (c)(6) (Storage for disposal).
2. The PCB/TRU waste must be received in sealed NRC Type B shipping casks containing sealed DOT Type 7A Package containers.
3. All PCB NRC Type B Packages, DOT Type 7A CH Packages, over the road transport vehicles, and storage areas must be properly marked in accordance with 40 CFR 761.40. An exception is granted for labeling PCB containers for PCB/RH TRU DOT Type 7A waste containers.
4. All PCB Items must be identified in the WIPP Waste Data System (WDS) to show the date of waste certification for disposal. This electronic database must show the date a PCB Item was removed from service for disposal and the date the PCB Item was sent to the Facility for disposal. This information must be provided to EPA upon request.
5. The Facility may store PCB Items for up to 59 days in the PAU after the date the Inner Containment Vessel (ICV) of the Package was sealed at the generator site. Prior to storing a sealed Package, the owner/operator shall verify that the ICV Closure Date for each Package is recorded in the WIPP Waste Information System (WWIS) database. The facility may store PCB Items for up to 60 days in the WHB Container Storage Unit. PAU and WHB are the approved storage areas listed, in Condition III. A., above with the exception of RH TRU waste in the Hot Cell which has a storage limit of 25 days.

E. PCB/TRU STORAGE AREA OPERATING REQUIREMENTS

1. If manifest discrepancies are noted, the PCB Items in a DOT type 7A container must be placed either in a storage area of the WHB on a Facility pallet, or inside an approved NRC Type B Package and placed either in the WHB or Parking Area Unit.
2. Adequate aisle space must be maintained in all WHB Unit PCB/TRU waste storage areas to allow unobstructed movement of fire-fighting personnel, spill- control equipment, and decontamination equipment.
3. Waste containers may not be stacked more than two containers high in the

approved storage areas except for the Hot Cell, a concrete shielded room for RH TRU mixed waste, where waste containers may be stored three high in a Facility Canister. Waste containers may not be stacked more than three containers high in the Hot Cell or disposal Panels.

IV. PCB/TRU DISPOSAL REQUIREMENTS

A. GENERAL OPERATING REQUIREMENTS

The handling and disposal of PCB/TRU waste must comply with the applicable portions of 40 CFR Part 761 except where waivers or exemptions have been granted either through regulation, this approval, or in writing by EPA.

B. PCB/TRU DISPOSAL OPERATING REQUIREMENTS

1. PCB/CH TRU waste must be received into the WHB through one of the three air-lock entries. PCB/RH TRU waste must be received into the WHB through the RH Bay shield door.
2. In the event of a spill of PCB/TRU mixed waste, personnel in the area of the spill shall be evacuated immediately and the area posted in accordance with the radiological practices in effect at the Facility. Contaminated areas or potentially contaminated areas shall not be available for entry until the radiation control technicians determine that conditions for reentry and radiological cleanup are complete. Samples and/or surveys shall be taken to determine the presence of radiological materials. Radiological materials shall be removed in accordance with Facility requirements, and the concrete shall be treated with a double wash/rinse with an EPA approved solvent for potential PCB contamination removal. After cleanup and decontamination activities are complete, the Facility may reopen the area for normal activity in accordance with Facility requirements.
3. PCB/TRU waste must only be transported underground through the "waste shaft" vertical transport shaft from the WHB and placed in the designated disposal Panel using standard procedures as defined in the Hazardous Waste Facility Permit (HWFP).
4. The waste volumes authorized for disposal in Panels 2 through 12 are listed in the following table. The owner/operator may increase the CH TRU waste capacities of any given panel by 35,300 cubic feet (1,000 cubic meters) or less after providing EPA Region 6 with a written notification of the increase. Larger increases in capacity, up to a 25 percent increase to the CH TRU waste capacities identified for a panel in the table below requires the Facility to notify EPA, Region 6 PCB Coordinator of the proposed increase and receive written approval for the increased capacity.

Panel Number	Maximum Capacity for CH Waste	Maximum Capacity for RH Waste
Panel 2	636,000 Cu. Ft.	N/A
Panel 3	662,150 Cu. Ft.	N/A
Panel 4	662,150 Cu. Ft.	12,570 Cu. Ft.
Panel 5	662,150 Cu. Ft.	15,720 Cu. Ft.
Panel 6	662,150 Cu. Ft.	18,860 Cu. Ft.
Panel 7	662,150 Cu. Ft.	22,950 Cu. Ft.
Panel 8	662,150 Cu. Ft.	22,950 Cu. Ft.
Panel 11	662,150 Cu. Ft.	22,950 Cu. Ft.
Panel 12	662,150 Cu. Ft.	22,950 Cu. Ft.

5. All PCB/TRU waste shipments that are not sampled must be considered to contain a PCB concentration greater than 500 parts per million (ppm).
6. PCB/TRU waste disposal records and reports must be prepared and maintained in accordance with the regulations appropriate to the Facility pursuant to 40 CFR Part 761, Subpart K (PCB Waste Disposal Records and Reports).
7. Management and disposal of PCB/TRU waste at the Facility must be consistent with the disposal operations for TRU mixed waste as defined by Parts 1, 2, 3, and 4 of the effective HWFP issued by the New Mexico Environment Department (NMED) pursuant to 20.4.1.900 NMAC incorporating 40 CFR § 270 (EPA Administered Permit Programs: The Hazardous Waste Permit Program of the Resource Conservation and Recovery Act (RCRA)).

V. CLOSURE AND POST-CLOSURE CARE

A. CLOSURE PLAN REQUIREMENTS

1. The owner/operator must comply with the Closure Plan requirements pursuant to 40 CFR § 761.65(d)(3)(viii).
2. Closure must comply with requirements for closure as specified by the HWFP issued by the NMED.
3. The Closure Plan (Appendix 2) submitted with the Facility's application in July 2022 is incorporated herein. As set forth at 40 C.F.R. 761.65(e)(2), the Closure Plan constitutes conditions to this Approval.

B. NOTICE OF CLOSURE

The owner/operator must notify the EPA Region 6 PCB Coordinator 30-days before closure of a disposal Panel is to begin, along with any proposed changes to the closure plan.

C. POST-CLOSURE CARE

1. Records required under 40 CFR 761.180(d) and (f) must be maintained for the times specified for closed disposal Panels.

2. Post-closure care of closed panels must comply with the requirements of the effective HWFP issued by the NMED.

VI. STANDARD APPROVAL CONDITIONS

A. SEVERABILITY AND RESERVATION OF RIGHTS

1. The conditions of this authorization are severable, and if any provision of this authorization, or any application of any provision, is held invalid, the remainder of this authorization shall not be affected thereby.
2. EPA reserves the right to modify (including by imposing additional conditions), revoke and reissue, or terminate this Approval when any of the following circumstances exist:
 - a. EPA has reason to believe the approved activities are not achieving the relevant standards or goals or otherwise are not in compliance with the Approval.
 - b. EPA has reason to believe the approved activities present or may present an unreasonable risk of injury to health or the environment;
 - c. EPA becomes aware of new or previously undisclosed information that may substantively impact its previous finding of no unreasonable risk and require modifications to this Approval; or
 - d. EPA issues new regulations or standards that impact conditions of this Approval.
3. When any of the circumstances described above exist, EPA reserves the right to require the facility to provide additional information relevant to the Agency's determination whether to modify, revoke and reissue, or terminate the Approval. This may include information to inform EPA's finding that the approved activity does not present an unreasonable risk of injury to health or the environment.
4. If the facility becomes aware of new or previously undisclosed information that may substantively impact EPA's previous finding that approved activities do not present an unreasonable risk of injury to health or the environment, the facility must provide that information to the Agency as soon as possible but no later than 30-days.

B. DUTY TO COMPLY

The owner/operator must comply with all applicable Federal, State, and local regulations, approvals, and permits including the effective HWFP issued by the NMED.

C. PERSONNEL SAFETY

The Facility personnel safety requirements and procedures for PCB handling, storage, transport, and disposal must comply with applicable federal occupational safety and health requirements.

D. DUTY TO MITIGATE

The owner/operator must correct any adverse impact on the environment resulting from noncompliance with this approval.

E. OPERATION AND MAINTENANCE

1. The owner/operator must at all times properly operate and maintain all systems of treatment and control (and related appurtenances) which are installed and used to achieve compliance with these Conditions of Approval. Proper operation and maintenance include effective performance, adequate funding, adequate operator staffing and training, and adequate laboratory and process controls including appropriate quality assurance procedures.
2. The owner/operator must provide training for employees that handle, transport, store, and/or dispose of PCB TRU waste. PCB training must be included in General Employee Training (GET), Hazardous Waste Worker training and Hazardous Waste Responder training. Training records and course materials for these training courses are maintained in accordance with Attachment F (Appendix 3) of the HWFP from NMED.

F. TRANSPORT

1. All transport vehicles owned or contracted by the owner/operator used for the transport of PCBs must be properly maintained, inspected, and certified in writing by a responsible official as meeting applicable safety standards under the DOT regulations before PCBs are transported on public highways. Copies of all safety certifications must be kept by the Facility or by the contracted carrier and shall be available to EPA for review upon request. Transporters of PCB waste must notify EPA of their PCB waste activities by filing EPA Form 7710- 53, "Notification of PCB Activity," prior to engaging in PCB waste handling activities.
2. All PCB waste must be shipped in NRC Type B Packages licensed by the Nuclear Regulatory Commission (NRC) with various configurations of containers meeting the DOT Type 7A drums and containers or other containers authorized by the NRC packaging Certificate of Compliance.

G. DUTY TO PROVIDE INFORMATION

1. The owner/operator must provide any relevant information which EPA may request to determine whether cause exists for modifying, revoking, reissuing, or terminating this approval, or determining compliance with this approval.
2. Upon request, the owner/operator must provide copies of records required to be prepared and maintained by the TSCA PCB regulations at this Facility.

H. INSPECTION AND ENTRY

The owner/operator must allow an authorized EPA representative, including contractors of EPA, upon presentation of credentials and/or other documents as may be required by law, to:

1. enter the Facility where PCBs are being handled, stored, or disposed,

2. have access to and copy, at reasonable times, any records that must be prepared and maintained by the TSCA PCB regulations or these Conditions of Approval,
3. inspect any facilities, equipment (including monitoring and control equipment), practices, or operations required under these Conditions of Approval or the TSCA PCB regulations, and
4. sample or monitor for the purpose of assuring that the Facility is operating in compliance with these Conditions of the Approval or the TSCA PCB regulations.

I. MONITORING AND RECORDS

1. All PCB records, documents, and reports required to be prepared and maintained by these Conditions of Approval and the PCB regulations must be maintained at the Facility and must be made available for inspection by authorized EPA representatives.
2. The owner/operator must maintain records of PCB/TRU waste in accordance with 40 CFR § 761.180(b).
3. Facility operating records of PCB/TRU waste disposal must be maintained as defined in the WIPP HWFP Part 1 - Section 1.13 and Part 4 – Section 4.8.2. All records required by 40 CFR Part 761 and this approval must be written in ink, typed, or put into electronic format. Any modification or correction of the records must be dated and initialed by the supervisor in charge.

J. NOTICE OF TRANSFER OF OWNERSHIP

The owner/operator must notify EPA at least thirty (30) days before transferring ownership of the Facility. The owner/operator must also submit to EPA at least thirty (30) days before such transfer, a notarized affidavit signed by the transferee stating that the transferee shall abide by the terms of this approval.

K. TWENTY-FOUR HOUR REPORTING OF NONCOMPLIANCE

1. If at any time the owner/operator finds it is in non-compliance with these Conditions of Approval, and that non-compliance may pose a risk to human health or the environment, it must notify the EPA Region 6 PCB Coordinator by telephone within 24 hours and must submit a written report within five (5) workdays.
2. If at any time the owner/operator finds it is in non-compliance with these Conditions of Approval, and that non-compliance does not pose a risk to human health or the environment, it must notify the EPA Region 6 PCB Coordinator by telephone or e-mail within 24 hours and must submit a written report within five (5) workdays. E-mail messages must confirm successful delivery by return e-mail.

L. OTHER INFORMATION

If the owner/operator finds that it has failed to submit any relevant facts in its application, or submitted incorrect information in any report to EPA, it must promptly submit such facts or information to the EPA Region 6 PCB Coordinator.

M. EMERGENCY PROCEDURES

1. The owner/operator must maintain an adequately trained onsite RCRA emergency coordinator to direct emergency procedures which could result from fires, explosions or releases of PCB containing waste at the Facility.
The owner/operator must submit the name and qualifications of the emergency coordinator within sixty (60) days of the effective date of this approval.
2. The owner/operator must maintain in good working order any equipment required to deal with onsite emergencies.
3. The owner/operator must comply with the WIPP RCRA Contingency Plan included in Attachment D of the HWFP (Appendix 4), which describes detailed emergency response actions to incidents involving TRU waste as modified to include incidents involving PCB/TRU waste.
4. The owner/operator must provide emergency response training to its emergency response personnel as required by Attachment F of the Facility HWFP (Appendix 3).

N. SPILLS

1. PCB spills occurring at the Facility or from any onsite transport vehicle must be cleaned up according to condition IV.B.2. of these Conditions of Approval for PCB/TRU mixed waste.
2. If spills cannot be cleaned up within the time required by the PCB Spill Cleanup Policy, the owner/operator must notify the EPA Region 6 PCB Coordinator of the circumstance of the spill, the estimated time of cleanup, and a justification for the delay of the cleanup. The EPA may order cessation of PCB disposal at the Facility if spills are not cleaned up in accordance with the PCB Spill Cleanup Policy.

O. DUTY TO NOTIFY

The owner/operator must notify the EPA Region 6 PCB Coordinator, in writing, at least thirty (30) days prior to any planned physical or operational change related to PCB handling and disposal that may require modification of this approval.

P. EFFECTIVE DATE

This approval becomes effective on the date of this letter and expires at midnight on the same day and month five years later. Please re-apply for re-authorization approval at least twelve months before the expiration date of this approval.

Q. STATEMENT IN COMPLIANCE WITH 40 CFR 761.65(d)(4)(i)

1. The United States Environmental Protection Agency, Region 6 (EPA) is modifying a Toxic Substances Control Act (TSCA) Approval issued to WIPP, to continue to operate a commercial storage and disposal facility for non-liquid polychlorinated biphenyls (PCB). The following criteria has satisfactorily met the requirements contained in 40 C.F.R. § 761.65(d)(2) by WIPP:

(i) WIPP, its principals, and its key employees responsible for the establishment or operation of the commercial storage facility are qualified to engage in the business of commercial storage of PCB waste. This finding is based on EPA's evaluation of key personnel information submitted with the Renewal Application, plus the Facility's compliance with the worker training plan (Appendix 3) as described in the Renewal Application.

(ii) WIPP possesses the capacity to handle the quantity of PCB waste which the facility has estimated will be the maximum quantity of PCB waste that will be handled at any one time at the facility. This finding is based on the information and calculations contained in the Hazards Waste Facility Permit, Part 3, Container Storage.

(iii) WIPP has certified compliance with the storage facility standards in 40 C.F.R. § 761.65(b) as found in the Hazardous Waste Facility Permit, Part 2, General Facility Conditions.

(iv) WIPP has developed a written closure plan for the facility that is deemed acceptable by the Land, Chemicals, and Redevelopment Director under the closure plan standards. This finding is based on EPA's evaluation of Appendix 2 of the Renewal Application, the requirements of which are incorporated into this Approval.

(v) WIPP is a federal facility and is exempt from the requirements of 40 C.F.R. § 761.65(f) and (g), in accordance with § 761.65(k).

(vi) WIPP's operation of the storage areas will not pose an unreasonable risk of injury to health or the environment. This finding is based on EPA's evaluation of the Renewal Application and all applicable regulations at 40 C.F.R. § 761, as set forth in this Approval.

(vii) There is not any known history of environmental civil violations or criminal convictions that evidences a pattern or practice of noncompliance that demonstrates the applicant's unwillingness or inability to achieve and maintain compliance with the regulations. This finding is based on EPA's evaluation of the information contained in the Modification request and a review of all available compliance data. All available information demonstrates that the Facility is in compliance with its current Approval and the TSCA PCB regulations at 40 CFR Section 761, and that the Facility's compliance history evinces no unwillingness or inability to achieve and maintain compliance with the regulations.

END OF APPROVAL CONDITIONS

Appendix 1 Map, Repository Horizon and Underground Waste Transport Routes

▲ WIPP-19

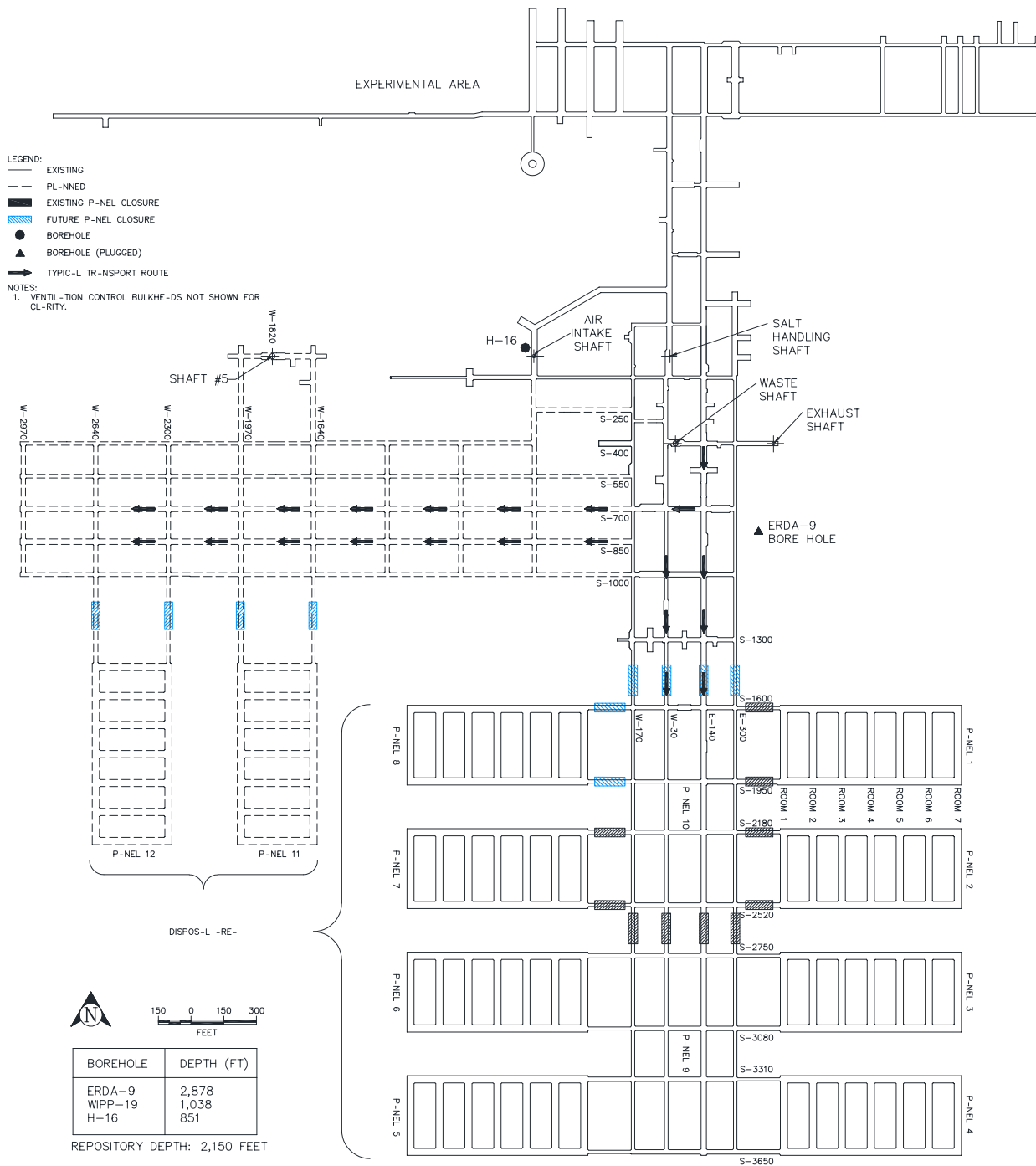

APPENDIX 2 - CLOSURE PLAN (REFERENCED FROM ATTACHMENT G IN HWFP)

Waste Isolation Pilot Plant
Hazardous Waste Facility Permit
Attachment G
October 2023

ATTACHMENT G

CLOSURE PLAN

TABLE OF CONTENTS

Introduction	3
G-1 Closure Plan	4
G-1a Closure Performance Standard	5
G-1a(1) Container Storage Units	5
G-1a(2) Miscellaneous Unit	6
G-1a(3) Post-Closure Care	7
G-1b Requirements	7
G-1c Maximum Waste Inventory	7
G-1d Schedule for Closure	8
G-1d(1) Schedule for Panel Closure	8
G-1d(2) Schedule for Final Facility Closure	8
G-1d(3) Extension for Closure Time	9
G-1d(4) Amendment of the Closure Plan	10
G-1e Closure Activities	10
G-1e(1) Panel Closure	11
G-1e(2) Decontamination and Decommissioning	12
G-1e(3) Performance of the Closed Facility	20
G-2 Notices Required for Disposal Facilities	21
G-2a Certification of Closure	21
G-2b Survey Plat	21
References	22

LIST OF TABLES

Table	Title
Table G-1	Anticipated Earliest Closure Dates for the Underground HWDUs
Table G-2	Anticipated Overall Schedule for Closure Activities
Table G-3	Governing Regulations for Borehole Abandonment

ATTACHMENT G

CLOSURE PLAN

Introduction

This Permit Attachment contains the Closure Plan that describes the activities necessary to close the Waste Isolation Pilot Plant (WIPP) individual units and facility. Since the current plans for operations extend over several decades, the Permittees will periodically reapply for an operating permit in accordance with 20.4.1.900 New Mexico Administrative Code (NMAC) (incorporating Title 40 of the Code of Federal Regulations (CFR) §270.10(h)). Consequently, this Closure Plan describes several types of closures. The first type is panel closure, which involves constructing closures for each of the underground hazardous waste disposal units (HWDUs) after they are filled. The second type is partial closure, which can be less than the entire facility and, therefore, less than an entire unit as described herein for the Waste Handling Building (WHB) Container Storage Unit (WHB Unit), the Parking Area Container Storage Unit (PAU), or Permit-related surface equipment, structures and contaminated soils. The third type of closure is final facility closure at the end of the Disposal Phase, which will entail “clean” closure of remaining surface storage units and construction of shaft seal systems for each shaft. Finally, in the event a new permit is not issued prior to expiration of an existing permit, a modification to this Closure Plan will be sought to perform contingency closure. Contingency closure defers the final closure of waste management facilities such as the WHB Unit, the conveyances, the shafts, and the haulage ways because these will be needed to continue operations with non-mixed Transuranic (TRU) waste.

The hazardous waste management units (HWMUs) addressed in this Closure Plan include the WHB Unit, the PAU, and Panels 1 through 8, Panel 11, and Panel 12, each consisting of seven rooms. In addition, this Closure Plan includes closures for Panels 9 and 10.

This plan was submitted to the New Mexico Environment Department (NMED) in accordance with 20.4.1.900 NMAC (incorporating 40 CFR §270.14(b)(13)). Closure at the panel level will include the construction of barriers that will contribute to limiting the emission of hazardous waste constituents from the panel into the mine ventilation air stream below levels that meet environmental performance standards. The Post-Closure Plan (Permit Attachment H) includes the implementation of institutional controls to limit access and groundwater monitoring to assess disposal system performance. Until final closure is complete and has been certified in accordance with 20.4.1.500 NMAC (incorporating 40 CFR §264.115), a copy of the approved Closure Plan and approved revisions will be on file at the WIPP facility and will be available to the Secretary of the NMED in accordance with 20.4.1.500 NMAC (incorporating 40 CFR §264.112(a)(2)) upon request.

This Closure Plan uses the terms Disposal Phase, facility closure period, and post-closure care period. The Disposal Phase began with the first waste emplacement in March 1999 and extends until the expiration of the Permit term, unless a timely Renewal Application has been submitted and the requirements of Permit Part 1, Section 1.7.3 have been met, or when the HWDUs have received the final volume of waste as specified in Permit Part 4, Table 4.1.1. The facility closure period is the 10-year period that begins once the final waste has been emplaced in the underground. The post-closure care period extends for 30-years after completion of facility closure period.

G-1 Closure Plan

This Closure Plan is prepared in accordance with the requirements of 20.4.1.500 NMAC (incorporating 40 CFR Part 264, Subparts G, I, and X), Closure and Post-Closure, Use and Management of Containers, and Miscellaneous Units. The WIPP underground HWDUs, shown on Figure M-43, will be closed under this Closure Plan to meet the performance standards in 20.4.1.500 NMAC (incorporating 40 CFR §264.601). The WIPP surface facilities, including the WHB Unit and the PAU, will be closed in accordance with 20.4.1.500 NMAC (incorporating 40 CFR §264.178). The Permittees may perform partial closure of the WHB Unit, PAU HWMUs, or Permit-related surface equipment, structures and contaminated soils prior to final facility closure and certification. For final facility closure, this plan also includes closure and sealing of the facility shafts in accordance with 20.4.1.500 NMAC (incorporating 40 CFR §264.601).

Following completion of waste emplacement in each underground HWDU, the HWDU will be closed. The Permittees will notify the NMED of the closure of each underground HWDU as specified in the schedule in Figure M-61. For the purpose of this Closure Plan, panel closure is defined as the process of rendering underground HWDUs in the repository inactive and closed according to the facility Closure Plan. The Post-Closure Plan (Permit Attachment H) addresses requirements for future monitoring that are deemed necessary for the post-closure period, prior to final facility closure.

For the purposes of this Closure Plan, final facility closure is defined as closure that will occur when permitted HWDUs are filled or have achieved their maximum capacities as outlined in Permit Part 4, Table 4.1.1, or when the WIPP facility achieves its capacity of 6.2 million cubic feet (ft³) (175,564 cubic meters (m³)) of Land Withdrawal Act (LWA)TRU waste volume. At final facility closure, the surface container storage areas will be closed. Equipment that cannot be decontaminated plus any derived waste resulting from decontamination will be placed in the last open underground HWDU. In addition, shafts and boreholes which lie within the WIPP Site Boundary and penetrate the Salado Formation (**Salado**) will be plugged and sealed, and surface and subsurface facilities and equipment will be decontaminated, if necessary, and removed and dispositioned appropriately or, alternatively, disposed in the last open underground HWDU as derived waste. The requirements in Permit Part 2, Section 2.3.3.4, *Chemical Incompatibility*, apply to surface and subsurface facilities and equipment to be disposed upon final facility closure. Final facility closure will be completed to demonstrate compliance with the Closure Performance Standards contained in 20.4.1.500 NMAC (incorporating 40 CFR §264.111, 178, and 601).

In the event the Permittees fail to obtain an extension of the hazardous waste permit in accordance with 20.4.1.900 NMAC (incorporating 40 CFR §270.51) or fail to obtain a new permit in accordance with 20.4.1.900 NMAC (incorporating 40 CFR §270.10(h)), the Permittees will seek a modification to this Closure Plan in accordance with 20.4.1.900 NMAC (incorporating 40 CFR §270.42) to accommodate a contingency closure. Under contingency closure, storage units will undergo clean closure in accordance with 20.4.1.500 NMAC (incorporating 40 CFR §264.178); waste handling equipment, shafts, and haulage ways will be inspected for hazardous waste residues (using, among other techniques, radiological surveys to indicate potential hazardous waste releases as described in Permit Attachment G3) and decontaminated as necessary; and underground HWDUs that contain radioactive mixed waste will be closed in accordance with the panel closure design described in this Closure Plan. Final facility closure, however, will be redefined and a time extension for final closure will be requested. A copy of this

Closure Plan will be maintained by the Permittees at the WIPP facility and at the U.S. Department of Energy (DOE) Carlsbad Field Office. The primary contact person at the WIPP facility is:

Manager, Carlsbad Field Office
U.S. Department of Energy
Waste Isolation Pilot Plant
P. O. Box 3090
Carlsbad, New Mexico 88221-3090
(575) 243-4432

G-1a Closure Performance Standard

The closure performance standard specified in 20.4.1.500 NMAC (incorporating 40 CFR §264.111), states that the closure shall be performed in a manner that minimizes the need for further maintenance; that minimizes, controls, or eliminates the escape of hazardous waste; and that conforms to the closure requirements of §264.178 and §264.601. These standards are discussed in the following paragraphs.

G-1a(1) Container Storage Units

Final or partial closure of the permitted container storage units (the WHB Unit and PAU) will be accomplished by removing waste and waste residues. Indication of waste contamination will be based, among other techniques, on the use of radiological surveys as described in Permit Attachment G3. Radiological surveys use very sensitive radiation detection equipment to indicate if there has been a potential release of TRU mixed waste, including hazardous waste components, from a container. This allows the Permittees to indicate potential releases that are not detectable from visible evidence such as stains or discoloration. Visual inspection and operating records will also be used to identify areas where decontamination is necessary. Contaminated surfaces will be decontaminated until radioactivity is below DOE-established radiological protection limits¹. Once surfaces are determined to be free of radioactive waste constituents, they will be sampled for hazardous waste contamination. Hazardous waste decontamination, if needed, will be conducted in accordance with the requirements of the Permit and the standards in 20.4.1.500 NMAC (incorporating 40 CFR Part 264). These surface decontamination activities will ensure the removal of waste residues to levels protective of human health and the environment. The facility may require decontamination during the Disposal Phase and at closure because of releases in February 2014 or subsequent releases for which immediate removal is not possible. Solid waste management units listed in Attachment K, Table K-4 will be subject to closure.

Once the container storage units are certified by the Permittees to be clean, no further maintenance is required. The facilities and equipment in these units will be available for other purposes. If portions of the facilities or equipment in these units, which require decontamination, cannot be decontaminated, these portions will be removed, and the resultant wastes will be managed consistent with radiological control procedures pursuant to 10 CFR Part 835.

¹ Title 10 CFR Part 835.

G-1a(2) Miscellaneous Unit

Post-closure migration of hazardous waste or hazardous waste constituents to ground or surface waters or to the atmosphere, above levels that will harm human health or the environment, will not occur due to facility engineering and the geological isolation of the unit. The engineering aspects of closure are centered on the use of panel closures on each of the underground HWDUs and final facility seals placed in the shafts. The design of the panel closure system is based on the criteria that the closure system for closed underground HWDUs will prevent migration of hazardous waste constituents in the air pathway in concentrations above health-based levels beyond the WIPP land withdrawal boundary during the Disposal Phase and facility closure period.

Consistent with the definitions in 20.4.1.101 NMAC (incorporating 40 CFR §260.10), the process of panel closure is considered partial closure because it is a process of rendering a part of the repository inactive and closed according to the approved underground HWDU partial closure plan. Panel closure will be complete when the panel closure system is emplaced and operational and when the NMED has been notified of the closure.

Shaft seals are designed to provide effective barriers to the inward migration of groundwater and the outward migration of gas and contaminated brine over two discrete time periods. Several components become effective immediately and are expected to function for 100 years. Other components become effective more slowly but provide permanent isolation of the waste. The final shaft seal design is specified in Permit Attachment G2.

The facility will be finally closed to minimize the need for continued maintenance. Protection of human health and the environment includes, but is not limited to:

- Prevention of any releases that may have adverse effects on human health or the environment due to the migration of waste constituents in the groundwater or in the subsurface environment [20.4.1.500 NMAC, incorporating 40 CFR §264.601(a)].
- Prevention of any releases that may have adverse effects on human health or environment due to migration of waste constituents in surface water, in wetlands, or on the soil surface [20.4.1.500 NMAC, incorporating 40 CFR §264.601(b)].
- Prevention of any release that may have adverse effects on human health or the environment due to migration of waste constituents in the air [20.4.1.500 NMAC, incorporating 40 CFR §264.601(c)].

As part of final facility closure, surface recontouring and reclamation will establish a stable vegetative cover, and further surface maintenance will not be necessary to protect human health and the environment. Prior to cessation of active controls, monuments will be emplaced to serve as long-term site markers to discourage activities that would penetrate the facility or impair the ability of the salt formation to isolate the waste from the surface environment for at least 10,000 years. The Federal government will maintain administrative responsibility for the repository site in perpetuity and will limit future use of the area.

If, during panel or final facility closure activities, unexpected events require modification of this Closure Plan to demonstrate compliance with closure performance standards, a Closure Plan

amendment will be submitted in accordance with 20.4.1.900 NMAC (incorporating 40 CFR §270.42).

G-1a(3) Post-Closure Care

The post-closure care period will begin after completion of the first panel closure and will continue for 30 years after final facility closure. The post-closure care period may be shortened or lengthened at the discretion of the NMED based on evidence that human health and the environment are being protected or that they are at risk. During the post-closure care period, the WIPP facility shall be maintained in a manner that complies with the environmental performance standards in 20.4.1.500 NMAC (incorporating 40 CFR §264.601). Post-closure activities are described in Permit Attachment H.

G-1b Requirements

The Permit specifies a sequential process for the closure of individual HWMUs at the WIPP facility. Each underground HWDU will undergo panel closure when waste emplacement in that HWDU is complete. Following waste emplacement in each underground HWDU, construction-side ventilation will be terminated, waste-disposal-side ventilation will be established in the next underground HWDU to be used, and the underground HWDU containing the waste will be closed. The Permittees will notify the NMED of the closure of each of the underground HWDUs as they are sequentially filled on a HWDU-by-HWDU basis. The HWMUs in the WHB and in the parking area will be closed as part of final facility closure of the WIPP facility.

The Permittees will notify the Secretary of the NMED in writing at least 60 days prior to the date on which closure activities are scheduled to begin.

G-1c Maximum Waste Inventory

The maximum waste inventory (maximum capacity) for the permitted HWDUs is established in Permit Part 4, Table 4.1.1. During the Disposal Phase, and in accordance with the LWA, the WIPP facility will receive no more than 6.2 million ft³ (175,564 m³) of LWA TRU waste volume, which may include up to 250,000 ft³ (7,079 m³) of remote-handled (RH) TRU waste. Excavations are mined as permitted when needed during operations to maintain a reserve of disposal areas. The amount of waste placed in each room is limited by structural and physical considerations of equipment and design. Transuranic mixed waste volumes include waste received from off-site generator locations as well as derived waste from disposal and decontamination operations. For closure planning purposes, a maximum achievable volume of TRU mixed waste per HWDU is listed in Permit Part 4, Table 4.1.1.

The maximum extent of operations during the term of this permit includes Panels 1 through 8 and Panels 10 through 12; the WHB Unit; and the PAU. Note that Panel 9 will not be used for TRU mixed waste disposal and Panel 10 is not authorized for waste emplacement under this permit. If other waste management units are permitted during the Disposal Phase, this Closure Plan will be revised to include the additional waste management units. The design basis for a panel assumes that it takes about 30 months to fill the HWDU and initiate panel closure (DOE, 1997). However, it is anticipated that Panel 7, Panel 8, and Panel 10 (if authorized in the future for TRU mixed waste disposal) will take longer than 30 months to fill due to the reduction in available ventilation capability, ground conditions in Panel 10 and associated remediation efforts, and radiological contamination in Panel 10. These assumptions have been used in

preparing the closure schedule in Table G-1. At any given time during disposal operations, it is possible that multiple rooms may be receiving TRU mixed waste for disposal at the same time. Underground HWDUs in which disposal has been completed (i.e., in which CH and RH TRU mixed waste emplacement activities have ceased) will undergo panel closure.

G-1d Schedule for Closure

For the purpose of establishing a schedule for closure, the final waste disposal will mark the end of the Disposal Phase and will occur when the Permit term expires, unless a timely Renewal Application has been submitted and the requirements of Permit Part 1, Section 1.7.3 have been met, or the permitted HWDUs are filled or have achieved their maximum capacities as outlined in Permit Part 4, Table 4.1.1, within the capacity limit of 6.2 million cubic feet (ft³) (175,564 cubic meters (m³)) of LWA TRU waste volume. The Permittees also assume closure will take 10 years. The Disposal Phase may be extended or shortened, within the authorized capacities and Permit term, depending on a number of factors, including the rate of waste approved for shipment to the WIPP facility and the schedules of TRU mixed waste generator sites, and future decommissioning activities.

G-1d(1) Schedule for Panel Closure

The anticipated schedule for the closure of the underground HWDUs is shown in Figure M-61. Underground HWDUs should be ready for closure according to the schedule in Table G-1. Table G-1 shows actual dates for completed activities and future dates based on the facility design parameters discussed in Section G-1c. These future dates are estimates for planning and permitting purposes. Actual dates may vary depending on the availability of waste from the generator sites.

In the schedule in Figure M-61, notification of intent to close occurs 30 days before placing the final waste in an HWDU. Once an HWDU is full, the Permittees will initially block ventilation through the HWDU as described in Permit Attachment A2, Section A2-2a(3) "Subsurface Structures," and then will assess the closure area for ground conditions and contamination so that a definitive schedule and closure location can be determined. If as the result of this assessment the Permittees determine that a panel closure cannot be emplaced in accordance with the schedule in this Closure Plan, a modification will be submitted requesting an extension to the time for closure.

G-1d(2) Schedule for Final Facility Closure

If, as is currently projected, the WIPP facility is dismantled at closure, surface facilities (except the hot cell portion of the WHB, which will remain as an artifact of the Permanent Marker System [PMS]) will be disassembled and either salvaged or disposed in accordance with applicable standards. Subsurface facilities and equipment will be disassembled and disposed or salvaged to the extent practicable based on underground mining practice. In addition, asphalt and crushed caliche that was used for paving will be removed, and the area will be recontoured and revegetated in accordance with a land management plan. A detailed closure schedule will be submitted in writing to the Secretary of the NMED, along with the notification of closure. Throughout the closure period, necessary steps will be taken to prevent threats to human health and the environment in compliance with applicable Resource Conservation and Recovery Act (RCRA) permit requirements. Figure M-62 presents an estimate of a final facility closure schedule.

The schedule for final facility closure is considered to be a best estimate because closure of the facility is driven by policies and practices established for the decontamination, if necessary, and decommissioning of radioactively contaminated facilities. These required activities include extensive radiological contamination surveys and hazardous constituent surveys using, among other techniques, radiological surveys to indicate potential hazardous waste releases. Both types of surveys will be performed at the areas of the WIPP site where hazardous waste were managed, as appropriate. These surveys, along with historical radiological survey records, will provide the basis for determining the disposition of structures, equipment, and components (i.e., disposal or decontamination for release off-site). Specifications will be developed for each structure to be removed. A cost benefit analysis may be needed to evaluate decontamination options if extensive decontamination is necessary. Individual equipment surveys, structure surveys, and debris surveys may be required prior to disposition. Size-reduction techniques may be required to dispose of mixed or radioactive waste at the WIPP site. Current DOE policy requires the preparation of a final decontamination and decommissioning (D&D) plan immediately prior to final facility closure. In this way, the specific conditions of the facility at the time D&D is initiated will be addressed. Section G-1e(2) provides a more detailed discussion of final facility closure activities.

Figure M-62 shows the schedule for the final facility closure consisting of decontamination, as needed, of the TRU waste-handling equipment, and of the aboveground equipment and facilities, including closure of surface HVMUs; decontamination of the shaft and haulage ways (if needed); disposal of decontamination derived wastes in the last open underground HWDU; and subsequent closure of this underground HWDU. Subsequent activities will include installation of repository shaft seals.

A schedule for final facility closure, showing anticipated durations for final facility closure activities, is shown in Table G-2. This schedule is based on notification of the intent to close as the initial activity, 60 days prior to the final facility closure start date. Schedule details for panel closures are shown on Table G-1.

G-1d(3) Extension for Closure Time

As indicated by the closure schedule presented in Figure M-62, the activities necessary to perform facility closure of the WIPP facility may require more than 180 days to complete because of additional stringent requirements for managing radioactive materials. Therefore, the Permit provides an extension of the 180-day final closure requirement in accordance with 20.4.1.500 NMAC (incorporating 40 CFR §264.113). During the extended closure period, the Permittees will continue to demonstrate compliance with applicable permit requirements and will take the steps necessary to prevent threats to human health and the environment as a result of TRU mixed waste management at the WIPP facility including all of the applicable measures in Permit Part 2.10, *Preparedness and Prevention*.

In addition, according to the schedules in Figure M-62, the final derived wastes that are generated as the result of decontamination activities will not be disposed of for 16 months after the initiation of final facility closure. In accordance with 20.4.1.500 NMAC (incorporating 40 CFR §264.113(a)), the Permit provides an extension of the 90-day limit to dispose of final derived waste resulting from the closure process. This provision is necessitated by the fact that the radioactive nature of the derived waste makes placement in the WIPP repository the best disposition, and the removal of these wastes will, by necessity, take longer than 90 days in accordance with the closure schedules. During this extended period of time, the Permittees will

take the steps necessary to prevent threats to human health and the environment, including compliance with applicable permit requirements. These steps include the applicable preparedness and prevention measures in Permit Part 2, Section 2.10, *Preparedness and Prevention*.

Finally, in the event the hazardous waste permit is not renewed as assumed in the schedule, the Permittees will submit a modification to the Closure Plan to implement a contingency closure that will allow the Permittees to continue to operate for the disposal of non-mixed TRU waste. This modification will include a request for an extension of the time for final facility closure. This modified Closure Plan will be submitted to the NMED for approval.

G-1d(4) Amendment of the Closure Plan

If it becomes necessary to amend the Closure Plan for the WIPP facility, the Permittees will submit a written notification of or request for a permit modification in accordance with 20.4.1.900 NMAC (incorporating 40 CFR §270.42). This notification of, or request for, a permit modification will describe any change in operation or facility design that affects the Closure Plan. The written notification of, or request for, a permit modification will include a copy of the amended Closure Plan for approval by the NMED. The Permittees will submit a written notification of, or request for, a permit modification to authorize a change in the approved plan, if:

- There are changes in operating plans or in the waste management unit facility design that affect the Closure Plan
- There is a change in the expected year of closure
- Unexpected events occur during panel or final facility closure that require modification of the approved Closure Plan
- Changes in State or Federal laws affect the Closure Plan
- Permittees fail to obtain permits for continued operations as discussed above

The Permittees will submit a written request for a permit modification with a copy of the amended Closure Plan at least 60 days prior to the proposed change in facility design or operation or within 60 days of the occurrence of an unexpected event that affects the Closure Plan. If the unexpected event occurs during final closure, the permit modification will be requested within 30 days of the occurrence. If the Secretary of the NMED requests a modification of the Closure Plan, a plan modified in accordance with the request will be submitted within 60 days of notification or within 30 days, if the change in facility condition occurs during final closure.

G-1e Closure Activities

Closure activities include those instituted for panel closure (i.e., closure of filled underground HWDUs), contingency closure (i.e., closure of surface HWMUs and decontamination of other waste handling areas), and final facility closure (i.e., closure of surface HWMUs, D&D of surface facilities and the areas surrounding the WHB, and placement of repository shaft seals). Panel closure systems will be emplaced to separate areas of the facility and to isolate panels. Permit Attachments G1 and G2 provide panel closure system and shaft seal designs, respectively.

Closure activities will meet the applicable quality assurance (QA)/quality control (QC) program standards in place at the WIPP facility. Facility monitoring procedures in place during operations will remain in place through final closure, as applicable.

G-1e(1) Panel Closure

Following completion of waste emplacement in each underground HWDU, the HWDU will be closed. A WIPP Panel Closure (WPC) will be emplaced in the panel access drifts, in accordance with the design in Permit Attachment G1 and the schedule in Figure M-61 and Table G-1. Alternatively, panels may be closed simultaneously by placing panel closures in the north-south mains (E-300, E-140, W-30, and W-170), as shown in Figure M-43. The panel closure system is designed to meet the following requirements that were established by the DOE for the design to comply with 20.4.1.500 NMAC (incorporating 40 CFR §264.601(a)):

- the panel closure system shall contribute to meeting the closure performance standards in Permit Part 6, Section 6.10.1 by mitigating the migration of volatile organic compounds (VOCs) from closed panels
- the panel closure system shall consider potential flow of VOCs through the disturbed rock zone (DRZ) in addition to flow through closure components
- the panel closure system shall perform its intended functions under loads generated by creep closure of the tunnels
- the panel closure system shall perform its intended function under the conditions of a postulated thermal runaway involving nitrate salt bearing waste (Golder, 2016)
- the nominal operational life of the closure system is 35 years, however, the inspection and maintenance, if needed, of accessible bulkheads can continue until the initiation of final facility closure
- the panel closure system may require minimal maintenance per 20.4.1.500 NMAC (incorporating 40 CFR 264.111)
- the panel closure system shall address the expected ground conditions in the waste disposal area
- the panel closure system shall be built of substantial construction and non-combustible material except for flexible flashing used to accommodate salt movement
- the design and construction shall follow conventional mining practices
- structural analysis shall use data acquired from the WIPP underground
- materials shall be compatible with their emplacement environment and function
- treatment of surfaces in the closure areas shall be considered in the design
- a QA/QC program shall verify material properties and construction

- construction of the panel closure system shall consider shaft and underground access and services for materials handling

The closure performance standard for air emissions from the WIPP facility is one excess cancer death in one million and a hazard index (HI) of 1 for a member of the public living outside the WIPP Site Boundary as specified in Permit Part 6, Section 6.10.1. Releases shall be below these limits for the facility to remain in compliance with standards to protect human health and the environment. The panel closure design has been shown, through analysis, to meet these standards, if emplaced in accordance with the specifications in Permit Attachment G1. Compliance will be demonstrated by the Repository VOC Monitoring Program (RVMP) in Permit Attachment N. Compliance with the standards established for the RVMP constitutes compliance with the closure standards in Permit Part 6, Table 6.10.1.

The design basis for this closure is such that the migration of hazardous waste constituents from closed panels during the operational and closure period would result in concentrations well below health-based standards. The source term used as the design basis included the average concentrations of VOCs from CH waste containers as measured in headspace gases through November 2010. The VOCs are assumed to have been released by diffusion through the container vents and are removed from the closed room by air leakage that occurs due to ventilation-related pressure differentials.

Diagrams of the panel closure design, the substantial barrier, and installation envelopes are depicted in Permit Attachment G1, Appendix G1-Band Attachment M, Figure M-63 and Figure M-42. Permit Attachment G1 provides the detailed design and the design analysis for the panel closure system. The Permittees shall use bulkheads as specified in Attachment G1 for the closure of filled panels. A run-of-mine (ROM) salt component, placed between two bulkheads, was included in the closure for Panel 9 and will be included in the closure for Panel 10. The substantial barrier in Figure M-63 will be installed in Panel 8. Substantial barriers were installed in Panel 7.

G-1e(2) Decontamination and Decommissioning

Decontamination is defined as those activities which are performed to remove contamination from surfaces and equipment that are not intended to be disposed of at the WIPP facility. The policy at the WIPP facility will be to decontaminate as many areas as possible or to fix the contaminants to the surface so they are not easily removable, consistent with radiological protection policy. Decontamination or fixing are part of closure activities and are a necessary activity in the clean closure of the surface container management units. Decontamination or fixing determinations are based upon radiological surveys.

Decommissioning is the process of removing equipment, facilities, or surface areas from further use and closing the facility. Decommissioning is part of final facility closure only and will involve the removal of equipment, buildings, closure of the shafts, and establishing active and passive institutional controls for the facility. Passive institutional controls are not included in the Permit.

The objective of D&D activities at the WIPP facility is to return the surface to as close to the preconstruction condition as reasonably possible, while protecting the health and safety of the public and the environment. Major activities required to accomplish this objective include, but are not limited to the following:

1. Review of operational records for historical information on releases
2. Visual examination of surface structures for evidence of spills or releases
3. Performance of site contamination surveys
4. Decontamination, if necessary, of usable equipment, materials, and structures including surface facilities and areas surrounding the WHB.
5. Disposal of equipment/materials that cannot be decontaminated but that meet the treatment, storage, and disposal facility waste acceptance criteria (TSDF-WAC) in an underground HWDU
6. Emplacement of panel closure system in the last HWDU
7. Emplacement of shaft seals²
8. Regrading the surface to approximately original contours
9. Initiation of active controls

This Closure Plan will be amended prior to the initiation of final closure activities to specify the methods to be used.

G-1e(2)(a) Hazards Survey

Before final closure activities begin, radiation protection personnel will conduct a hazards survey of the unit(s) being closed. A release of radionuclides could also indicate a release of hazardous constituents. If radionuclides are not detected, sampling for hazardous constituents will still be performed if there is documentation or visible evidence that a spill or release has occurred. The purpose of the hazards survey will be to identify potential contamination concerns that may present hazards to workers during the closure activities and to specify any control measures necessary to reduce worker risk. This survey will provide the information necessary for the health physics personnel to identify worker qualifications, personal protective equipment (PPE), safety awareness, work permits, exposure control programs, and emergency coordination that will be required to perform closure related activities.

G-1e(2)(b) Determine the Extent of Contamination

The first activities performed as part of decontamination include those needed to determine the extent of any contamination that needs to be removed or fixed prior to decommissioning a facility. This includes activities 1 to 3 above and, as can be seen by the schedules in Figures M-61 and M-62 (Items B and C), these surveys are anticipated to take 10 months to perform, including obtaining the results of any sample analyses. The process of identifying areas that require decontamination or fixing include three sources of information. First, operating records will be reviewed to determine where contamination has previously been found as the result of

² For the purposes of planning, the conclusion of shaft sealing is used by the DOE as the end of closure activities and the beginning of the Post-Closure Care Period.

historical releases and spills. Even though releases and spills in the above ground storage units will have been cleaned up at the time of occurrence, newer equipment and technology may allow further cleaning. Second, surfaces of facilities and structures will be examined visually for evidence of spills or releases. Finally, extensive detailed contamination surveys will be performed to document the level of cleanliness for surface structures and equipment that are subject to decontamination. If equipment or areas are identified as contaminated, the Permittees will notify NMED as specified in Permit Part 1, and a plan and procedure(s) will be developed and implemented to address decontamination-related questions, including:

- Should the component be decontaminated or disposed of as waste?
- What is the most cost-effective method of decontaminating the component?
- Will the decontamination procedures adequately contain the contamination?

Radiological and hazardous constituent surveys will be used in determining the presence of hazardous waste and hazardous waste residues in areas where spills or releases have occurred. Radiological surveys are described in Permit Attachment G3. For contamination that is cleaned up, once cleanup of the radioactivity has been completed, the surface will be sampled for the hazardous constituents associated with the EPA Hazardous Waste Numbers specified in Permit Attachment B to determine that they, too, have been cleaned up. Sampling and analysis protocols will be consistent with EPA's document SW-846 (EPA, 2015).

G-1e(2)(c) Decontamination Activities

Once the extent of contamination is known, radiological control activities (e.g., decontamination, fixing) will be planned and performed. Consistent with radiological control procedures pursuant to 10 CFR Part 835, decontamination activities will be performed, as necessary. Hazardous waste decontamination, if needed, will be conducted in accordance with the requirements of the Permit and the standards in 20.4.1.500 NMAC (incorporating 40 CFR Part 264). Radiological control and the control of hazardous waste residues are the primary criteria used in the design of decontamination activities. Radiological control procedures require that careful planning and execution be used in decontamination activities to prevent the exposure of workers beyond applicable standards and to prevent the further spread of contamination. Careful control of entry, cleanup, and ventilation are vital components of radiological control activities. The level of care mandated by DOE orders and occupational protection requirements results in closure activities that will exceed the 180 days allowed in 20.4.1.500 NMAC (incorporating 40 CFR §264.113(b)). Decontamination activities are included as item 4 above and are shown on the schedule for final facility closure (Figure M-62) as Activities D, E, and F. These activities are anticipated to have a duration of 20 months for both contingency closure and for final facility closure. The result of these activities is the clean closure of the surface container management units. Under contingency closure, the other areas that have been decontaminated will not be closed. Instead, they will remain in use for continued waste management activities involving non-mixed waste. Under final facility closure, other areas that are decontaminated are eligible for closure.

The operating philosophy of the WIPP Project, which is described as "Start Clean – Stay Clean," was intended to provide for minimum need for decontamination at closure. Decontamination during the Disposal Phase and at closure may be needed because of releases in February 2014. Decontamination activities are managed consistent with radiological control procedures pursuant to 10 CFR Part 835, which includes the as-low-as-reasonably-achievable (**ALARA**)

principle. The ALARA principle is an approach/philosophy to radiation protection to manage and control exposures (both individual and collective) to the work force and to the general public to as low as is reasonable, taking into account social, technical, economic, practical, and public policy considerations. It is assumed that the process of localized surface decontamination will remove the hazardous waste constituents along with the radioactive waste constituents.

Decontamination activities will be coordinated with closure activities so that areas that have been decontaminated will not be recontaminated. Waste resulting from decontamination activities will be surveyed and analyzed for the presence of radioactive contamination and a determination of the hazardous constituents associated with the EPA Hazardous Waste Numbers specified in Part A of the Permit Application. The waste will be characterized as non-radioactive/non-hazardous, hazardous, mixed, or radioactive and will be packaged and handled appropriately. Mixed and radioactive waste, classified as TRU mixed waste, will be managed in accordance with the applicable Permit requirements. Derived mixed waste collected during decontamination activities that are generated before repository shafts have been sealed will be emplaced in the facility, if appropriate, or will be managed together with decontamination derived waste collected after the underground is closed. This waste will be classified and shipped off site to an appropriate, permitted facility for treatment, if necessary, and for disposal.

Removal of Hazardous Waste Residues

Because of the type of waste management activities that will occur at the WIPP facility, waste residues that may be encountered during the operation of the facility and at closure may include derived waste. Derived wastes result from the management of the waste containers or may be collected as part of the closure activities (such as those during which wipes were used to sample the containers and equipment for potential radioactive contamination or those involving solidified decontamination solutions, the handling of equipment designated for disposal, and the handling of residues collected as a result of spill cleanup). Derived wastes collected during the operation and closure of the WIPP facility will be identified and managed as TRU mixed wastes. These wastes will be disposed in an active underground HWDU. Decontamination and decommissioning derived wastes and equipment designated for disposal will be placed in an underground HWDU before closure of that unit.

Surface Container Storage Units

The procedures employed for waste receipt at the WIPP facility minimize the likelihood for any waste spillage to occur on the surface outside the WHB. TRU mixed waste is shipped to the WIPP facility in approved shipping containers (i.e., CH or RH Packages) that are not opened until they are inside the WHB. Therefore, it is unlikely that soil in the Parking Area Unit or elsewhere in the vicinity of the WHB will become contaminated with TRU mixed waste constituents as a result of TRU mixed waste management activities. An evaluation of the soils in the vicinity of the WHB will only be necessary if an event resulting in a release of hazardous waste has occurred outside the WHB.

The "Start Clean—Stay Clean" operating philosophy of the WIPP Project will minimize the need for decontamination of the WHB during decommissioning and closure. Procedures for opening shipping containers in the WHB limit the opportunity for waste spillage.

Should the need for decontamination of the WHB arise, the following methods may be employed, as appropriate, for the hazardous constituent/contaminant type and extent:

- Chemical cleaning (e.g., water, mild detergent cleanser, and polyvinyl alcohol)
- Nonchemical cleaning (e.g., sandblasting, grinding, high-pressure water spray, scabblers, pistons and needle scalers, ice-blast technology, dry-ice blasting)
- Removal of contaminated components such as pipe and ductwork

Waste generated as a result of WHB decontamination activities will be managed as derived waste in accordance with applicable Permit requirements and will be emplaced in the last open underground HWDU for disposal.

Contaminated Underground Equipment

The Waste Shaft conveyance, associated waste handling equipment, and underground support equipment (e.g., mining equipment, carts) that has become contaminated with hazardous waste constituents associated with TRU mixed waste will be decontaminated or characterized and dispositioned (i.e., disposed of as derived waste) as part of both contingency and final facility closure. Procedures for detection and sampling will be as described above. Equipment cleanup will be as above using chemical or nonchemical techniques.

Personnel Decontamination

Personal protective equipment worn by personnel performing closure activities in areas determined to be contaminated will be disposed of appropriately. Disposable PPE used in such areas will be placed into containers and managed as TRU mixed waste. Non-disposable PPE will be decontaminated, if possible. Non-disposable PPE that cannot be decontaminated will be managed as TRU mixed waste.

In accordance with DOE policy, TRU mixed waste PPE will be considered to be contaminated with all of the hazardous waste constituents contained in the containers that have been managed within the unit being closed. Wastes collected as a result of closure activities and that may be contaminated with radioactive and hazardous constituents will be considered TRU mixed wastes. These wastes will be managed as derived wastes and disposed of in the final open underground HWDU, as described in Permit Attachment A2. Such waste, collected as the result of closure of the WIPP facility, will be disposed of in the final open underground HWDU. The requirements in Permit Part 2, Section 2.3.3.4, *Chemical Incompatibility*, apply to the derived wastes to be disposed upon final facility closure.

Cleanup Criteria

Radiological decontamination will be managed consistent with radiological control procedures, or to whatever levels that may be established by DOE³ at the time of cleanup.

³ Title 10 CFR Part 835

Hazardous waste decontamination will be conducted in accordance with standards in 20.4.1.500 NMAC (incorporating 40 CFR Part 264) or as incorporated into the Permit.

Final Contamination Sampling and Quality Assurance

Verification samples will be analyzed by a laboratory that has been qualified by the DOE according to a written program with strict criteria. The QA requirements of EPA/SW-846, "Test Methods for Evaluating Solid Waste" (EPA, 2015), will be met for hazardous constituent sampling and analyses.

Quality Assurance/Quality Control

Because decisions about closure activities may be based, in part, on analyses of samples of potentially contaminated surfaces and media, a program to ensure reliability of analytical data is essential. Data reliability will be ensured by following a QA/QC program that mandates adequate precision and accuracy of laboratory analyses. Field documentation will be used to document the conditions under which each sample is collected. The documented QA/QC program in place at the WIPP facility will meet applicable RCRA QA requirements.

Field blanks and duplicate samples will be collected in the field to determine potential errors introduced in the data from sample collection and handling activities. To determine the potential for cross-contamination, rinsate blanks (consisting of rinsate from decontaminated sampling equipment) will be collected and analyzed in accordance with applicable EPA guidance. Acceptance criteria for QA/QC hazardous constituent sample analyses will adhere to the most recent version of EPA SW-846 or other applicable EPA guidance.

G-1e(2)(d) Dismantling

G-1e(2)(d)(1) Dismantling During Final Closure

Final facility closure will include dismantling of structures on the surface and in the underground. These are items 6 and 7 above and are represented as Activity G in the final facility closure schedule in Figure M-62. During dismantling, priority will be given to contaminated structures and equipment that cannot be decontaminated to assure these are properly disposed of in the remaining open underground HWDU in a timely manner. All such facilities and equipment are expected to be removed and disposed of 16 months after the initiation of closure. Dismantling of the balance of the facility, including those structures and equipment that are not included in the application and are not used for TRU mixed waste management, is anticipated to take an additional 66 months. The placement of D&D waste into the final underground HWDU may, by necessity, involve the placement of uncontainerized bulk materials such as concrete components, building framing, structural members, disassembled or partially disassembled equipment, or containerized materials in non-standard waste boxes. Such placement will only occur if it can be shown that it is protective of human health and the environment and will be described in an amendment to the Closure Plan. Identification of bulk items is not possible at this time since their size and quantity will depend on the extent of non-removable contamination.

G-1e(2)(d)(2) Dismantling of Permit-Related Surface Equipment, Structures, and Contaminated Soils During Partial Closure

Partial closure may include dismantling of Permit-related structures and/or equipment and removal of contaminated soils on the surface prior to final closure. During dismantling, priority will be given to structures and equipment contaminated with hazardous waste or hazardous waste constituents that cannot be decontaminated due to the presence of radioactivity to ensure these are properly disposed of at the WIPP facility or at another designated disposal facility in a timely manner. It should be noted that the placement of D&D waste into a WIPP HWDU may, by necessity, involve the placement of uncontainerized bulk materials such as concrete components, building framing, structural members, disassembled or partially disassembled equipment, or containerized materials in non-standard waste boxes. Such placement will only occur if it can be shown that it is protective of human health and the environment and items are described in the operating record. Identification of bulk items is not possible at this time since their size and quantity will depend on the extent of non-removable contamination. The requirements in Permit Part 2, Section 2.3.3.4, Chemical Incompatibility, apply to these items to be disposed upon final facility closure.

G-1e(2)(e) Closure of Open Underground HWDU

The closure of the final underground HWDU is shown by Activity H in Figure M-62. This closure will be consistent with the description in Section G-1e(1) and the design in Permit Attachment G1. Detailed closure schedules for underground HWDUs are given in Figure M-61 and Table G-1.

G-1e(2)(f) Final Facility Closure

Final facility closure includes several activities designed to assure both the short-term isolation of the waste and the long-term integrity of the disposal system. These include the placement of plugs in boreholes that penetrate the salt and the placement of the repository sealing system. In addition, the surface will be returned to as near its original condition as practicable and will be readied for the construction of markers and monuments that will provide permanent marking of the repository location and contents.

Figure M-43 identifies where three existing boreholes overlie the proximate area of the repository footprint. Of these identified boreholes in Figure M-43, all but ERDA-9 are terminated hundreds of feet above the repository horizon. Only ERDA-9, which is accounted for in long-term performance modeling, is drilled through the repository horizon, near the WIPP facility excavations.

To mitigate the potential for migration beyond the repository horizon, the DOE has specified that borehole seals be designed to limit the volume of water that could be introduced to the repository from the overlying water-bearing zones and to limit the volume of contaminated brine released from the repository to the surface or water-bearing zones.

Borehole plugging activities have been underway since the 1970s, from the early days of the development of the WIPP facility. Early in the exploratory phase of the project, a number of boreholes were sunk in Lea and Eddy counties. After the WIPP site was situated in its current location, an evaluation of vertical penetrations was made by Christensen and Peterson (1981).

As an initial criterion, any borehole that connects a fluid-producing zone with the repository horizon becomes a plugging candidate.

Grout plugging procedures are routinely performed in standard oil-field operations; however, quantitative measurements of plug performance are rarely obtained. The Bell Canyon Test reported by Christensen and Peterson (1981) was a field test demonstration of the use of cementitious plugging materials and modification of existing industrial emplacement techniques to suit repository plugging requirements. Cement emplacement technology was found to be "generally adequate to satisfy repository plugging requirements." Christensen and Peterson (1981) also report "that grouts can be effective in sealing boreholes, if proper care is exercised in matching physical properties of the local rock with grout mixtures. Further, the reduction in fluid flow provided by even limited length plugs is far in excess of that required by bounding safety assessments for the WIPP." The governing regulations for plugging and/or abandonment of boreholes are summarized in Table G-3.

The proposed repository sealing system design will prevent water from entering the repository and will prevent gases or brines from migrating out of the repository. The proposed design includes the following subsystems and associated principal functions:

- Near-surface: to prevent subsidence at and around the shafts
- Rustler Formation: to prevent subsidence at and around the shafts and to ensure compliance with federal and New Mexico groundwater protection requirements
- Salado: to prevent transporting hazardous waste constituents beyond the point of compliance specified in Permit Part 5

The repository sealing system will consist of natural and engineered barriers within the WIPP repository that will withstand forces expected to be present because of rock creep, hydraulic pressure, and probable collapses in the repository and will meet the closure requirements of 20.4.1.500 NMAC (incorporating 40 CFR §264.601 and §264.111). Permit Attachment G2 presents the final repository sealing system design.

Once shaft sealing is completed, the Permittees will consider closure complete and will provide the NMED with a certification of such within 60 days.

G-1e(2)(g) Final Contouring and Revegetation

In the preparation of its Final Environmental Impact Statement (DOE, 1980), the DOE committed that restore the site to as near to its original condition as is practicable. This involves removal of access roads, unneeded utilities, fences, and any other structures built by the DOE to support WIPP operations. Provisions would be left for active post-closure controls of the site and for the installation of long-term markers and monuments for the purpose of permanently marking the location of the repository and waste. Permit Attachment H, Section H-1a(1) discusses the active and long-term controls proposed for the WIPP facility. Installation of borehole seals are anticipated to take 12 months, shaft seals 52 months, and final surface contouring 8 months.

G-1e(2)(h) Closure, Monuments, and Records

A record of the WIPP facility shall be listed in the public domain in accordance with the requirements of 20.4.1.500 NMAC (incorporating 40 CFR §264.116). Active access controls will be employed for at least the first 100 years after final facility closure. In addition, a passive control system consisting of monuments or markers will be erected at the site to inform future generations of the location of the WIPP repository (see "Permanent Marker Conceptual Design Report" [DOE, 1996]).

This Permit requires only a 30-year post-closure period. This is the maximum post-closure time frame allowed in an initial Permit for any facility, as specified in 20.4.1.500 NMAC (incorporating 40 CFR §264.117(a)). The Secretary of the NMED may shorten or extend the post-closure care period at any time in the future prior to completion of the original post-closure period (30 years after the completion of construction of the shaft seals). The Permanent Marker Conceptual Design Report and other provisions during the first 100 years after closure are addressed under another federal regulatory program.

Closure of the WIPP facility will contribute to the following:

- Prevention of the intrusion of fluids into the repository by sealing the shafts
- Prevention of human intrusion after closure
- Minimization of future physical and environmental surveillance

Detailed records shall be filed with local, state, and federal government agencies to ensure that the location of the WIPP facility is easily determined and that appropriate notifications and restrictions are given to anyone who applies to drill in the area. This information, together with land survey data, will be on record with the U.S. Geological Survey and other agencies. The federal government will maintain permanent administrative authority over those aspects of land management assigned by law. Details of post-closure activities are in Permit Attachment H.

G-1e(3) Performance of the Closed Facility

20.4.1.500 NMAC (incorporating 40 CFR §264.601) requires that a miscellaneous unit be closed in a manner that protects human health and the environment. The RCRA Part B permit application addressed the expected performance of the closed facility during the 30-year post closure period. Groundwater monitoring will provide information on the performance of the closed facility during the post-closure care period, as specified in Permit Attachment H, Section H-1a(2) (Monitoring).

The principal barriers to the movement of hazardous constituents from the facility or the movement of waters into the facility are the halite of the Salado (natural barrier) and the repository seals (engineered barrier). Data and calculations that support this discussion are presented in Renewal Application Addendum N1 (DOE, 2020). The majority of the calculations performed for the repository are focused on long-term performance and making predictions of performance over the first 300-years of the 10,000-year performance assessment. In the short term (300 years), the repository is reaching a steady state configuration where the hypothetical brine inflow rate is affected by the increasing pressure in the repository due to gas generation and creep closure. These three phenomena are related in the numerical modeling performed to support the permit application. The modeling parameters, assumptions and methodology are described in detail in Renewal Application Addendum N1 (DOE, 2020).

G-2 Notices Required for Disposal Facilities

G-2a Certification of Closure

Within 60 days after completion of closure activities for a HWMU (i.e., for each storage unit and each disposal unit), the Permittees will submit to the Secretary of the NMED a certification that the unit (and, after completion of final closure, the facility) has been closed in accordance with the specifications of this Closure Plan. The certification will be signed by the Permittees and by an independent New Mexico registered professional engineer. Documentation supporting the independent registered engineer's certification will be furnished to the Secretary of the NMED with the certification.

G-2b Survey Plat

Within 60 days of completion of closure activities for each underground HWDU, and no later than the submission of the certification of closure of each underground HWDU, the Permittees will submit to the Secretary of the NMED a survey plat indicating the location and dimensions of hazardous waste disposal units with respect to permanently surveyed benchmarks. The plat will be prepared and certified by a professional land surveyor and will contain a prominently displayed note that states the Permittees' obligation to restrict disturbance of the hazardous waste disposal unit. In addition, the land records in the Eddy County Courthouse, Carlsbad, New Mexico, will be updated through filing of the final survey plats.

References

Christensen, C. L., and Peterson, E. W. 1981. "Field-Test Programs of Borehole Plugs in Southeastern New Mexico." In *The Technology of High-Level Nuclear Waste Disposal Advances in the Science and Engineering of the Management of High-Level Nuclear Wastes*, P. L. Hofman and J. J. Breslin, eds., SAND79-1634C, DOE/TIC-4621, Vol. 1, pp. 354–369. Technical Information Center of the U.S. Department of Energy, Oak Ridge, TN.

DOE, see U.S. Department of Energy

EPA, see U.S. Environmental Protection Agency

Golder Associates Inc. (Golder), 2016, Design Report – WIPP Panel Closure report number 0632213 R1 Rev 1, Lakewood, Colorado, October 2016.

U.S. Department of Energy, 1980, "Final Environmental Impact Statement, Waste Isolation Pilot Plant," DOE/EIS 0026, U.S. Department of Energy, Washington, D.C.

U.S. Department of Energy, 1997, Resource Conservation and Recovery Act Part B Permit Application, Waste Isolation Pilot Plant (WIPP), Carlsbad, New Mexico, Revision 6.5, 1997, Chapters D and I.

U.S. Department of Energy, 1996, "Passive Institutional Controls Conceptual Design Report," from Appendix PIC of the Compliance Certification Application, DOE/CAO 1996-2184, U.S. Department of Energy, Carlsbad, NM.

U.S. Department of Energy, 2020, WIPP Hazardous Waste Facility Permit Renewal Application, Carlsbad, New Mexico, March 2020.

U.S. Environmental Protection Agency, 2015, "Test Methods for Evaluating Solid Waste," SW-846, U.S. Environmental Protection Agency, Washington, D.C.

TABLES

**Table G-1
Anticipated Earliest Closure Dates for the Underground HWDUs**

HWDU	Operations Start	Operations End	Closure Start ^a	Closure End ^b
PANEL 1	3/99*	3/03*	3/03*	5/20*
PANEL 2	3/03*	10/05*	10/05*	5/20*
PANEL 3	4/05*	2/07*	2/07*	8/19*
PANEL 4	1/07*	5/09*	5/09*	8/19*
PANEL 5	3/09*	7/11*	7/11*	8/19*
PANEL 6	3/11*	1/14*	1/14*	8/19*
PANEL 7	9/13*	10/22*	10/22*	2/23*
PANEL 8	11/22	4/26	4/26	10/26
PANEL 9**	N/A	N/A	N/A	N/A
PANEL 10	8/25	9/30	10/30	3/31
PANEL 11	8/25	7/28	8/28	2/29
PANEL 12	7/28	6/31	7/31	1/32

* Actual month and year

** Panel 9 was not used for TRU mixed waste disposal. Panels 3, 4, 5 and 6 were closed by placing closures in Panel 9 in the north-south mains (E-300, E-140, W-30 and W-170), as shown in Figure G-1, pursuant to Section G-1e(1).

^a The point of closure start is defined as 60 days following notification to the NMED of closure.

^b The point of closure end is defined as 180 days following placement of final waste in the panel.

NOTE: For the purposes of preparing the closure schedule, the "Operations Start" date for each additional HWDU is the same as the "Operations End" date of the immediately prior HWDU. The "Operations End" date for each additional HWDU is 30 months after the "Operations Start" date. The "Closure Start" date for each additional HWDU is 1 month after the "Operations End" date. The "Closure End" date for each additional HWDU is 6 months after the "Operations End" date. N/A--Not Applicable

**Table G-2
 Anticipated Overall Schedule for Final Facility Closure Activities**

Activity	Final Facility Closure Durations	
	Start Month	Duration
Notify NMED of Intent to Close WIPP (or to Implement Contingency Closure)	Month -2	N/A
Perform Contamination Surveys in both Surface Storage Areas	Month 0	6 Months
Sample Analysis	Month 2	8 Months
Decontamination as Necessary of both Surface Storage Areas	Month 8	8 Months
Final Contamination Surveys of both Surface Storage Areas	Month 16	8 Months
Sample Analysis	Month 20	8 Months
Prepare and Submit Container Management Unit Closure Certification	Month 28	4 Months
Dispose of Closure-Derived Waste and Equipment*	Month 2	14 Months
Closure of Open Underground HWDU panel	Month 16	8 Months
Install Borehole Seals	Month 24	12 Months
Install Repository Seals	Month 32	52 Months
Recontour and Revegetate	Month 84	8 Months
Prepare and Submit Final (Contingency) Closure Certification	Month 84	2 Months
Post-closure Monitoring	Month 86	Up to 30 Years

N/A--Not Applicable

Refer to Figure M-62 and Permit Attachment G1, Appendix G1-B for precise activity titles.

*The requirements in Permit Part 2, Section 2.3.3.4, *Chemical Incompatibility*, apply to the equipment to be abandoned upon final facility closure.

**Table G-3
Governing Regulations for Borehole Abandonment**

Federal or State Land	Type of Well or Borehole	Governing Regulation	Summary of Requirements
Both	Groundwater Surveillance	State and Federal regulation in effect at time of abandonment	Monitor wells no longer in use shall be plugged in such a manner as to preclude migration of surface runoff or groundwater along the length of the well. Where possible, this shall be accomplished by removing the well casing and pumping expanding cement from the bottom to the top of the well. If the casing cannot be removed, the casing shall be ripped or perforated along its entire length if possible, and grouted. Filling with bentonite pellets from the bottom to the top is an acceptable alternative to pressure grouting.
Federal	Oil and Gas Wells	43 CFR Part 3160, §§ 3162.3-4	The operator shall promptly plug and abandon, in accordance with a plan first approved in writing or prescribed by the authorized officer.
Federal	Potash	43 CFR Part 3590, § 3593.1	(b) Surface boreholes for development or holes for prospecting shall be abandoned to the satisfaction of the authorizing officer by cementing and/or casing or by other methods approved in advance by the authorized officer. The holes shall also be abandoned in a manner to protect the surface and not endanger any present or future underground operation, any deposit of oil, gas, or other mineral substances, or any aquifer.
State	Oil and Gas Well Outside the Oil-Potash Area	State of New Mexico, Oil Conservation Division, Rule 202 (eff. 3-1-91)	B. Plugging (1) Prior to abandonment, the well shall be plugged in a manner to permanently confine all oil, gas, and water in the separate strata where they were originally found. This can be accomplished by using mud-laden fluid, cement, and plugs singly or in combination as approved by the Division on the notice of intention to plug. (2) The exact location of plugged and abandoned wells shall be marked by the operator with a steel marker not less than four inches (4") in diameter, set in cement, and extending at least four feet (4') above mean ground level. The metal of the marker shall be permanently engraved, welded, or stamped with the operator name, lease name, and well number and location, including unit letter, section, township, and range.
State	Oil and Gas Wells Inside the Oil-Potash Area	State of New Mexico, Oil Conservation Division, Order No. R-111-P (eff. 4-21-88)	F. Plugging and Abandonment of Wells (1) All existing and future wells that are drilled within the potash area, shall be plugged in accordance with the general rules established by the Division. A solid cement plug shall be provided through the salt section and any water-bearing horizon to prevent liquids or gases from entering the hole above or below the salt selection. It shall have suitable proportions—but no greater than three (3) percent of calcium chloride by weight—of cement considered to be the desired mixture when possible.

ATTACHMENT G1

WIPP PANEL CLOSURE DESIGN DESCRIPTION AND SPECIFICATIONS

Adapted from the October 2016 Design Report – WIPP Panel Closure

ATTACHMENT G1

WIPP PANEL CLOSURE DESIGN DESCRIPTION AND SPECIFICATIONS

TABLE OF CONTENTS

G1-1	Introduction.....	4
G1-2	WPC Description.....	4
	G1-2a Permit Design Requirements.....	4
	G1-2b Design Component Descriptions.....	4
	G1-2b(1) Steel Bulkhead.....	5
	G1-2b(2) ROM Salt.....	5
G1-3	Constructability.....	5
G1-4	Technical Specifications.....	6
G1-5	Drawings.....	6
G1-6	References.....	6

LIST OF TABLES

Table	Title
Table G1-1	WIPP Panel Closure Technical Specifications
Table G1-2	WIPP Panel Closure Drawings

LIST OF APPENDICES

Appendix G1-A	Technical Specifications
Appendix G1-B	Drawings

LIST OF ABBREVIATIONS/ACRONYMS

Permit	WIPP Hazardous Waste Facility Permit
ROM	run-of-mine
WIPP	Waste Isolation Pilot Plant
WPC	WIPP Panel Closure

ATTACHMENT G1

WIPP PANEL CLOSURE DESIGN DESCRIPTION AND SPECIFICATIONS

G1-1 Introduction

An important aspect of repository operations at the Waste Isolation Pilot Plant (WIPP) facility is the closure of waste disposal panels, also referred to as Hazardous Waste Disposal Units, under the Resource Conservation and Recovery Act. Each one of Panels 1 through 8, 11, and 12 consists of a panel air-intake drift, a panel air-exhaust drift, and seven rooms. Panels 9 and 10 consist of the main entries (North to South) and cross entries (East to West) to Panels 1-8. The closure of individual panels shall meet the closure requirements described in Attachment G and shall be built in accordance with the specifications in this attachment. This attachment describes the panel closure design and presents the applicable specifications and requirements for fabrication, installation, and maintenance of the WIPP Panel Closure (WPC).

The design discussed in this attachment is based on the Design Report, prepared by Golder Associates (Golder, 2016). Calculations demonstrating compliance with the volatile organic compounds emission standards are included with the Design Report. Calculations addressing the performance of the WPC under the geometries in the access drifts and main entries, including an assessment of the required length of the run-of-mine (ROM) salt component, are also included in the Design Report. The specifications for standard steel bulkheads and ROM salt are included as Attachment G1 Appendix G1-A *Technical Specifications* and Attachment G1 Appendix G1-B *Drawings*.

G1-2 WPC Description

The WPC consists of WPC-A and WPC-B. The WPC-A is the design for Panels 1 through 8, 11, and 12. They shall be closed using out-bye bulkheads in the panel intake and exhaust drifts. The WPC-A with ROM salt is also installed in Panel 9 in the main entries between S-2750 and S-2520 as the closures for Panels 3 through 6. The WPC-B is the closure design for Panel 10. It consists of a combination of in-bye and out-bye bulkheads and a length of ROM salt placed in the main entries north of S-1600. The WPC locations are depicted in Permit Attachment G1, Appendix G1-B.

G1-2a Permit Design Requirements

The applicable design requirements are provided in Permit Attachment G, Section G-1e(1). The WPC meets these design requirements as documented in the Design Report.

G1-2b Design Component Descriptions

The following subsections present a description of the WPC components. Individual specifications address shaft and underground access and materials handling, construction quality control, treatment of surfaces in the closure areas, and applicable design and construction standards.

The WPC-A consists of a standard steel bulkhead in the panel access drifts, near the intersection with the main entries or relocated to the main north-south drifts as determined by the geotechnical engineer. This bulkhead is referred to as the closure/out-bye bulkhead and it

will be maintained for as long as it is accessible. Additional ventilation barriers may remain in the panels as part of the operational controls prior to WPC installation. These ventilation barriers include steel bulkheads, brattice cloth and chain link, as well as concrete block walls in Panels 1, 2, and 5. These ventilation barriers are not part of the WPC design and will not impact the WPC-A bulkheads nor will they impede construction and maintenance of closure bulkheads. WPC-A with ROM salt has been emplaced in the main entries between Panels 9 and 10 (between S-2520 and S-2750).

The WPC-B design for the closure installed in the main entries north of Panel 10 (north of S-1600) consists of ROM salt between in-bye and out-bye bulkheads as shown in Permit Attachment G1, Appendix G1-B.

G1-2b(1) Steel Bulkhead

A bulkhead (shown in Permit Attachment G1, Appendix G1-B) serves to close panels by blocking ventilation to the intake and exhaust access drifts of the panel and preventing personnel access. This use of a bulkhead is a standard practice and the closure bulkhead shall be constructed as a typical WIPP facility bulkhead. The bulkhead will consist of a steel member frame covered with sheet metal. Telescoping tubular steel or functionally equivalent material shall be used to bolt the bulkhead to the floor and roof. Flexible flashing material such as a rubber conveyor belt (or other appropriate material) will be attached to the steel frame and the salt as a gasket, thereby providing an effective yet flexible blockage to ventilation air. The steel bulkheads will be maintained for as long as they are accessible to workers. In this regard, accessible bulkheads will be repaired, renovated, or replaced as required. Permit Attachment E, Table E-1 provides the schedule for inspecting panel closure bulkheads.

G1-2b(2) ROM Salt

Run-of-mine salt material from mining operations will be used in the main entries north of Panel 10. The salt will be emplaced to a specified design length based on geomechanical calculations described in detail in the Design Report.

G1-3 Constructability

The WPC-A and WPC-B can be constructed using available technologies for the construction of bulkheads. The use of bulkheads is a standard practice at the WIPP facility and the closure bulkheads will be constructed as typical WIPP facility bulkheads. Run-of-mine salt is available from mining operations in sufficient quantities. The construction methods and materials required for the ROM salt placement north of Panel 10 will use available technologies as discussed in the Design Report.

Conventional WIPP facility mining practices will be used for the WPC construction. Work packages will be prepared for the fabrication and installation of steel bulkheads and will list the materials used, the equipment used, special precautions, and limitations. Each work package will address location-specific prerequisites for installing the closure components, will contain the bulkhead specifications, as appropriate, and the location where the closure components are to be installed. Details on the conventional mining practices and work package preparation are discussed in the Design Report and, further construction details are given in the technical specifications included in Attachment G1, Appendix G1-A.

Waste Isolation Pilot Plant
Hazardous Waste Facility Permit
Attachment G1
October 2023

G1-4 Technical Specifications

The technical specifications are included in Attachment G1, Appendix G1-A, and are listed in Table G1-1.

G1-5 Drawings

The drawings are included in Attachment G1, Appendix G1-B and are listed in Table G1-2.

G1-6 References

Golder Associates Inc. (Golder), 2016, Design Report – WIPP Panel Closure report number 0632213 R1 Rev 1, Lakewood, Colorado, October 2016.

Waste Isolation Pilot Plant
Hazardous Waste Facility Permit
Attachment G1
October 2023

TABLES

**Table G1-1
 WIPP Panel Closure Technical Specifications**

Division 1 – General Requirements	
Section 01010	Summary of Work
Section 01090	Reference Standards
Section 01400	Contractor Quality Control
Section 01600	Material and Equipment
Division 2 – Site Work	
Section 02010	Mobilization and Demobilization
Section 02222	Excavation
Division 3 – WPC Components	
Section 03100	Run-of-Mine Salt
Section 03200	Steel Bulkheads

**Table G1-2
 WIPP Panel Closure Drawings**

Drawing Number	Title
262-001	WIPP Panel Closure (WPC) Title Sheet
262-002	WPC Locations
262-003	Typical Panel Layout and Mined Entry Cross-Sections
262-004	WPC Details – Bulkhead and ROM Salt Locations
262-005	WPC Details – Bulkhead Front-View and Attachment Detail

**ATTACHMENT G1
APPENDIX G1-A**

TECHNICAL SPECIFICATIONS

**WIPP PANEL CLOSURE
WASTE ISOLATION PILOT PLANT
CARLSBAD, NEW MEXICO**

**ATTACHMENT G1
APPENDIX G1-A**

TECHNICAL SPECIFICATIONS

TABLE OF CONTENTS

DIVISION 1 – GENERAL REQUIREMENTS.....	5
Section 01010 – Summary of Work.....	6
Part 1 – General.....	6
1.1 Scope.....	6
1.2 Scope of Work.....	6
1.3 Definitions and Abbreviations.....	8
1.4 List of Drawings.....	9
1.5 Work by Others.....	9
1.6 Contractor’s Use of Site.....	9
1.7 Contractor’s Use of Facilities.....	10
1.8 Work Sequence.....	10
1.9 Work Plans.....	10
1.10 Health and Safety Plan (HASP).....	10
1.11 Contractor Quality Control Plan (CQCP).....	10
1.12 Submittals.....	11
Part 2 – Products.....	11
Part 3 – Execution.....	11
Section 01090 – Reference Standards.....	12
Part 1 – General.....	12
1.1 Scope.....	12
1.2 Quality Assurance.....	12
1.3 Schedule of References.....	12
Part 2 – Products.....	13
Part 3 – Execution.....	13
Section 01400 – Contractor Quality Control.....	14
Part 1 – General.....	14
1.1 Scope.....	14
1.2 Related Sections.....	14
1.3 Contractor Quality Control Plan (CQCP).....	14
1.4 References and Standards.....	14
1.5 Quality Assurance.....	15
1.6 Tolerances.....	15
1.7 Testing Services.....	15
1.8 Inspection Services.....	15
1.9 Submittals.....	15
Part 2 – Products.....	16
Part 3 – Execution.....	16
3.1 General.....	16
3.2 Contractor Quality Control Plan.....	16
3.3 Tests.....	17
3.4 Testing Laboratory.....	18
3.5 Inspection Services.....	18

3.6	Completion Inspection	18
3.7	Documentation	19
3.8	Notification of Noncompliance.....	19
Section 01600 – Material and Equipment		20
Part 1 – General.....		20
1.1	Scope.....	20
1.2	Related Sections	20
1.3	Equipment.....	20
1.4	Products	20
1.5	Transportation and Handling.....	20
1.6	Storage and Protection	21
1.7	Substitutions.....	21
Part 2 – Products.....		21
Part 3 – Execution		21
DIVISION 2 – SITE WORK.....		22
Section 02010 – Mobilization and Demobilization		23
Part 1 – General.....		23
1.1	Scope	23
1.2	Related Sections	23
Part 2 – Products.....		23
Part 3 – Execution		23
3.1	Mobilization of Equipment and Facilities to Site.....	23
3.2	Use of Site.....	23
3.3	Use of Existing Facilities	23
3.4	Demobilization of Equipment and Facilities	24
3.5	Site Cleanup.....	24
Section 02222 – Excavation.....		25
Part 1 – General.....		25
1.1	Scope	25
1.2	Related Sections	25
1.3	Reference Documents	25
1.4	Field Measurements and Survey	25
Part 2 – Products.....		25
Part 3 – Execution		25
3.1	Excavation for Surface Preparation and Leveling of Areas for Steel Bulkhead and ROM Salt Placement.....	25
3.2	Disposing of Excavated Materials	26
3.3	Field Measurements and Survey	26
DIVISION 3 – WPC Components.....		27
SECTION 03100 – Run-of-Mine Salt		28
Part 1 – General.....		28
1.1	Scope.....	28
1.2	Related Sections	28
1.3	Submittals for Review and Approval	28
1.4	Quality Assurance	28
Part 2 – Products.....		28
2.1	Salt Material	28
Part 3 – Execution		28

Waste Isolation Pilot Plant
 Hazardous Waste Facility Permit
 Attachment G1, Appendix G1-A
 October 2023

3.1	General	28
3.2	Installation	28
3.3	Field Quality Control	29
SECTION 03200 – Steel Bulkheads		30
Part 1 – General		30
1.1	Scope	30
1.2	Related Sections	30
1.3	Submittals for Review and Approval	30
1.4	Quality Assurance	30
Part 2 – Products		30
2.1	Bulkhead Material	30
Part 3 – Execution		30
3.1	General	30
3.2	Fabrication	30
3.3	Installation	31
3.4	Field Quality Control	31
3.5	Product Acceptance	31

LIST OF TABLES

Table	Title
Table 1	Minimum ROM Salt Lengths

Waste Isolation Pilot Plant
Hazardous Waste Facility Permit
Attachment G1, Appendix G1-A
October 2023

DIVISION 1 – GENERAL REQUIREMENTS

Section 01010 – Summary of Work

Part 1 – General

1.1 Scope

This section includes the following:

- Scope of Work
- Definitions and Abbreviations
- List of Drawings
- Work by Others
- Contractors Use of Site
- Contractors Use of Facilities
- Work Sequence
- Work Plan
- Health and Safety Plan (HASP)
- Contractor Quality Control Plan (CQCP)
- Submittals

1.2 Scope of Work

The contractor shall furnish all labor, materials, equipment, and tools to construct Waste Isolation Pilot Plant (WIPP) Panel Closure (WPC), including the WPC-A for Panels 1 through 9, and the WPC-B to the north of Panel 10. Each WPC-A in each of Panels 1-9 consists of a single steel bulkhead while the WPC-B north of Panel 10 will include dual bulkheads with run-of-mine (ROM) salt installed between. Run-of-mine salt will also be used as part of the Panel 9 closure. Nuclear Waste Partnership LLC (NWP) may elect to perform any portion or all of the work herein. Details are as follows:

- Install WPC-A in the air-intake and the air-exhaust drifts of Panel 1, 2, and 5 with the explosion-isolation walls (block walls), as shown on the drawings and described in these specifications. The WPC-A consists of an out-by steel bulkhead. Alternatively, install WPC-A in the main entries and cross-drifts in order to close multiple panels simultaneously based on the direction of the geotechnical engineer.
- Install WPC-A in the air-intake and the air-exhaust drifts of Panel 3, 4, 6, 7, and 8 without the explosion-isolation walls (block walls), as shown on the drawings and described in these specifications. The WPC-A consists of an out-by steel bulkhead. Alternatively, install WPC A in the main entries and cross-drifts in order to close multiple panels simultaneously based on the direction of the geotechnical engineer.
- Install WPC-A in the main entries between Panels 9 and 10, as shown on the drawings and described in these specifications. The WPC-A consists of an out-by steel bulkhead. Run-of-mine salt will also be used as part of the Panel 9 closure.
- Install WPC-B in the main entries north of Panel 10, as shown on the drawings and described in these specifications. The WPC-B consists of an in-by and an out-by steel bulkhead with ROM salt installed between.

Unless otherwise agreed by NWP, the contractor shall use NWP supplied equipment underground. Such use shall be coordinated with NWP and may include the use of NWP qualified operators.

The scope of work shall include but not necessarily be limited to the following units of work:

- Develop work plan, HASP, and CQCP, and submit for approval
- Prepare and submit any other plans requiring approval
- Mobilize to site
- Coordinate construction with WIPP operations
- Perform the following operations for the air-intake drift and the air-exhaust drift that do not contain block walls (Panels 3, 4, 6, 7, and 8):
 - Prepare the surfaces for the out-bye steel bulkhead placement
 - Construct the out-bye steel bulkhead
 - Clean up construction areas in underground and above ground
 - Submit required record documents
 - Demobilize from site
- Perform the following operations for the air-intake drift and the air-exhaust drift with block walls (Panels 1, 2, and 5):
 - Prepare the surfaces for the out-bye steel bulkhead placement
 - Construct the out-bye steel bulkhead
 - Clean up construction areas in underground and above ground
 - Submit required record documents
 - Demobilize from site
- Perform the following operations for the main entries between Panels 9 and 10:
 - Prepare the surfaces for the ROM salt placement
 - Place ROM salt material in multiple layers
 - Prepare the surfaces for the out-bye steel bulkhead placement
 - Construct the out-bye steel bulkhead
 - Clean up construction areas in underground and above ground
 - Submit required record documents
 - Demobilize from site
- Perform the following operations for the main entries north of Panel 10:
 - Prepare the surfaces for the in-bye steel bulkhead placement
 - Construct the in-bye steel bulkhead
 - Prepare the surfaces for the ROM salt placement
 - Place ROM salt material in multiple layers
 - Prepare surfaces for the out-bye steel bulkhead placement
 - Construct the out-bye steel bulkhead

- Clean up construction areas in underground and above ground
- Submit required record documents
- Demobilize from site

1.3 Definitions and Abbreviations

Definitions

Block wall – Existing mortared concrete block wall adjacent to the panel waste disposal area as shown in the drawings; also known as explosion-isolation wall

Creep – Viscoplastic deformation of salt under deviatoric stress

Partial closure – The process of rendering a part of the hazardous waste management unit in the underground repository inactive and closed according to approved facility closure plans

Run-of-mine salt – A salt backfill obtained from mining operations and emplaced in an uncompacted state

Volatile organic compound (VOC) – Any VOC with Hazardous Waste Facility Permit emission limits

Nuclear Waste Partnership LLC (NWP) – the construction management authority

Abbreviations/Acronyms

ACI	American Concrete Institute
ANSI	American National Standards Institute
ASTM	American Society for Testing and Materials
CFR	Code of Federal Regulations
CQCP	Contractor Quality Control Plan
DOE	U.S. Department of Energy
DWG	drawing
EPA	U.S. Environmental Protection Agency
HASP	Health and Safety Plan
JHA	Job Hazard Analysis
LHD	load haul dump
LLC	Limited Liability Corporation
MSHA	U.S. Mine Safety and Health Administration
NWP	Nuclear Waste Partnership LLC
ROM	Run-of-mine
USACE	U.S. Army Corps of Engineers
VOC	volatile organic compound
WIPP	Waste Isolation Pilot Plant
WPC	WIPP Panel Closure

1.4 List of Drawings

The following drawings were prepared as a part of the WPC design report (Attachment G1, Appendix G1-B, Drawings):

DWG 262-001	WIPP Panel Closure (WPC) Title Sheet
DWG 262-002	WPC Locations
DWG 262-003	Typical Panel Layout and Mined Entry Cross-Sections
DWG 262-004	WPC Details – Bulkhead and ROM Salt Locations
DWG 262-005	WPC Details – Bulkhead Front-View and Attachment Detail

1.5 Work by Others

Survey

All survey work to locate, control, confirm, and complete the work will be performed by NWP. All survey work for record purposes will be performed by NWP. NWP may elect to perform certain portions or all of the work. The work performed by the NWP will be defined prior to the contract. Unless otherwise agreed by NWP, the contractor shall use underground equipment furnished by NWP for construction of the steel bulkheads and placement of ROM salt. Underground mining personnel who are qualified for the operation of such underground construction equipment may be made available to the contractor. The use of NWP equipment shall be coordinated with NWP.

1.6 Contractor's Use of Site

Site Conditions

The WIPP site is located near Carlsbad in southeastern New Mexico, as shown on the drawings. The underground arrangements and location of the WIPP waste disposal panels are shown on the drawings. The work is to construct steel bulkheads in the air-intake drifts, air-exhaust drifts, and main access drifts between Panels 9 and 10 after cessation of the disposal phase in the specific panel. The work may include installation of steel bulkheads at alternative locations. Alternative locations will be specified by the NWP geotechnical engineer prior to installation activities. Dual bulkheads will be emplaced in the main entries north of Panel 10 after cessation of all disposal activities, and ROM salt placed between these bulkheads at a length to be specified by NWP. Run-of-mine salt will also be used as part of the Panel 9 closure. The waste disposal panels are located approximately 2,150 feet (655 meters) below the ground surface. The contractor shall visit the site, and become familiar with the site and site conditions, prior to preparing a bid proposal.

Contractor's Use of Site

Areas at the ground surface will be designated for the contractor's use in assembling and storing equipment and materials. The contractor shall utilize only those areas so designated.

Limited space within the underground area will be designated for the contractor's use for storage of material and setup of equipment.

1.7 Contractor's Use of Facilities

Existing facilities at the site available for use by the contractor are:

- Waste shaft conveyance
- Salt skip hoist
- 460-volt AC, 3-phase power
- Water (underground, at waste shaft only) (above ground, at a location designated by NWP)

Additional information on mobilization and demobilization to these facilities is presented in Section 02010.

1.8 Work Sequence

Work sequence shall be as shown on the drawings and as directed by NWP. NWP will designate the order in which panels are to be closed.

1.9 Work Plans

The contractor shall prepare work plans fully describing the proposed fabrication, installation, and construction for each WIPP panel closure. The work plan shall define proposed materials, equipment, and construction methods. The work plan shall state supporting processes, procedures, materials safety data sheets, and regulations by reference. The work plans shall address precautions related to the Job Hazards Check List. The work plan shall address limitations such as hold and witness points. The work plans shall address prerequisites for work. NWP shall approve the work plan and no work shall be performed prior to approval of the work plan.

1.10 Health and Safety Plan (HASP)

The contractor shall obtain, review, and agree to applicable portions of the existing WIPP Safety Manual, WP 12-1. The contractor shall prepare a project-specific HASP taking into account applicable sections of the WIPP Safety Manual. Personnel performing work shall be qualified to work underground. Personnel operating heavy construction equipment shall be qualified to operate such equipment. The contractor shall also perform a Job Hazard Analysis (JHA) in accordance with WP 12-1. NWP shall approve the HASP and JHA and no work shall be performed prior to approval of the HASP and JHA.

1.11 Contractor Quality Control Plan (CQCP)

The contractor shall prepare a CQCP identifying all personnel and procedures necessary to produce an end product that complies with the contract requirements. The CQCP shall comply with applicable NWP requirements, including operator training and qualification; and Section 01400, Contractor Quality Control, of this specification. NWP shall approve the CQCP and no work shall be performed prior to approval of the CQCP.

1.12 Submittals

Submittals shall be in accordance with NWP submittal procedures and as required by the individual specifications.

Part 2 – Products

Not used.

Part 3 – Execution

Not Used.

END OF SECTION

Section 01090 – Reference Standards

Part 1 – General

1.1 Scope

This section includes the following:

- Provision of Reference Standards at Site
- Acronyms used in Contract Documents for Reference Standards

1.2 Quality Assurance

For products or workmanship specified by association, trade, or Federal Standards, the contractor shall comply with requirements of the standard, except when more rigid requirements are specified or are required by applicable codes.

Conform to reference by date of issue current on the date of the owner-contractor agreement.

The contractor shall obtain, at the contractor's own expense, a copy of the standards referenced in the individual specification sections and shall maintain that copy at the job site until completion and acceptance of the work.

Should specified reference standards conflict with the contract documents, the contractor shall request clarification from Nuclear Waste Partnership LLC (**NWP**) before proceeding.

1.3 Schedule of References

Various publications referenced in other sections of the specifications establish requirements for the work. These references are identified by document number and title. The addresses of the organizations responsible for these publications are listed below.

ANSI	American National Standards Institute 25 West 43rd Street New York, New York 10036 Ph: 212-642-4900 Fax: 212-398-0023
ASTM	ASTM International 100 Barr Harbor Drive P.O. Box C700 West Conshohocken, Pennsylvania 19428-2959 Ph: 610-832-9585 Fax: 610-832-9555

Waste Isolation Pilot Plant
Hazardous Waste Facility Permit
Attachment G1, Appendix G1-A
October 2023

CFR	Code of Federal Regulations Government Printing Office 732 North Capital Street, NW Washington, District of Columbia 20401-0001 Ph: 202-512-1800 Fax: 202 512-2104
EPA	Environmental Protection Agency 1445 Ross Avenue, Suite 1200 Dallas, Texas 75202-2733 Ph: 214-665-2200
FTM-STD	Federal Test Method Standards Standardization Documents Order Desk, Building 4D 700 Robbins Avenue Philadelphia, Pennsylvania 19111-5094 Ph: 215-697-2179 Fax: 215-697-2978
NIST	National Institute of Standards and Technology 100 Bureau Drive, Stop 1000 Gaithersburg, Maryland 20899-1000 Ph: 301-975-6478 Fax: 301-975-8295
NTIS	National Technical Information Service U.S. Department of Commerce 5301 Shawnee Road Alexandria, Virginia 22312 Ph: 703-605-6000 Fax: 703-605-6900

Part 2 – Products

Not used.

Part 3 – Execution

Not used.

END OF SECTION

Section 01400 – Contractor Quality Control

Part 1 – General

1.1 Scope

This section includes the following:

- Contractor Quality Control Plan (CQCP)
- Reference Standards
- Quality Assurance
- Tolerances
- Testing Services
- Inspection Services
- Submittals

1.2 Related Sections

- 01090 – Reference Standards
- 01600 – Material and Equipment
- 02222 – Excavation
- 03100 – Run-of-Mine Salt

1.3 Contractor Quality Control Plan (CQCP)

The contractor shall prepare a CQCP describing the methods to be used to verify the performance of the engineered components of the Waste Isolation Pilot Plant (WIPP) Panel Closure (WPC). The quality control plan for the run-of-mine (ROM) salt shall detail the methods the contractor proposes to meet the minimum requirements, and the standard quality control test methods to be used to verify compliance with minimum requirements. Equipment methods employed shall be traceable to standard quality control tests as approved in the CQCP. No work shall be performed prior to Nuclear Waste Partnership LLC (NWP) approval of the CQCP.

1.4 References and Standards

Refer to individual specification sections for standards referenced therein, and to Section 01090, Reference Standards, for general listing. Additional standards will be identified in the CQCP.

Standards referenced in this section are as follows:

ASTM E 329-01b	Standard Specification for Agencies Engaged in Construction Inspection, Testing, or Special Inspection
ASTM E 543-02	Standard Practice for Agencies Performing Nondestructive Testing

1.5 Quality Assurance

The contractor shall:

- Monitor suppliers, manufacturers, products, services, site conditions, and workmanship to produce work of specified quality
- Comply with specified standards as minimum quality for the work except where more stringent tolerances, codes, or specified requirements indicate higher standards or more precise workmanship
- Perform work with qualified persons to produce required and specified quality

1.6 Tolerances

The contractor shall:

- Monitor excavation, fabrication, and tolerances to produce acceptable work. The contractor shall not permit tolerances to accumulate.

1.7 Testing Services

Unless otherwise agreed by NWP, the contractor shall employ an independent firm qualified to perform the testing services and other services specified in the individual specification sections, and as may otherwise be required by NWP. Testing and source quality control may occur on or off the project site.

The testing laboratory, if used, shall comply with applicable sections of the reference standards and shall be authorized to operate in the State of New Mexico.

Testing equipment shall be calibrated at reasonable intervals traceable either to the standards from the National Institute of Standards and Technology or to accepted values of natural physical constants.

1.8 Inspection Services

The contractor may employ an independent firm to perform inspection services as a supplement to the contractor's quality control as specified in the individual specification sections, and as may be required by NWP. Inspection may occur on or off the project site.

The inspection firm shall comply with applicable sections of the reference standards.

1.9 Submittals

The contractor shall submit a CQCP as described herein.

Prior to start of work, if a testing laboratory is used, the contractor shall submit for approval the testing laboratory name, address, telephone number, and name of responsible officer of the firm, as well as a copy of the testing laboratory compliance with the referenced American Society for Testing and Materials (ASTM) standards, and a copy of the report of laboratory

facilities inspection made by Materials Reference Laboratory of National Institute of Standards and Technology with memorandum of remedies of any deficiencies reported by the inspection.

The contractor shall submit the names and qualifications of personnel proposed to perform the required inspections, along with their individual qualifications and certifications. Once approved by NWP, these personnel shall be available as may be required to promptly and efficiently complete the work.

Part 2 – Products

Not used.

Part 3 – Execution

3.1 General

The contractor is responsible for quality control and shall establish and maintain an effective quality control system. The quality control system shall consist of plans, procedures, and organization necessary to produce an end product that complies with the contract requirements. The quality control system shall cover construction operations, both on site and off site, and shall be keyed to the proposed construction sequence. The project superintendent will be held responsible for the quality of work on the job. The project superintendent in this context is the individual with the responsibility for the overall management of the project, including quality and production.

3.2 Contractor Quality Control Plan

3.2.1 General

The contractor shall supply, not later than 30 days after receipt of notice to proceed, the CQCP, which implements the requirements of the Contract. The CQCP shall identify personnel, procedures, control, instructions, tests, records, and forms to be used. Construction shall not begin until the CQCP is approved by NWP.

3.2.2 Content of the CQCP

The CQCP shall cover construction operations, both on site and off site, including work by subcontractors, fabricators, suppliers, and purchasing agents and shall include, as a minimum, the following items:

- A description of the quality control organization, including a chart showing lines of authority and acknowledgment that the Contractor Quality Control (CQC) staff shall implement the control system for all aspects of the work specified.
- The name, qualifications (in resume format), duties, responsibilities, and authorities of each person assigned a CQC function.
- A description of CQCP responsibilities and a delegation of authority to adequately perform the functions described in the CQCP, including authority to stop work.

- Procedures for scheduling, reviewing, certifying, and managing submittals, including those of subcontractors, off-site fabricators, suppliers, and purchasing agents. These procedures shall be in accordance with NWP submittal procedures.
- Control, verification, and acceptance testing procedures as may be necessary to ensure that the work is completed to the requirements of the drawings and specifications.
- Procedures for tracking deficiencies from identification, through acceptable corrective action, to verification that identified deficiencies have been corrected.
- Reporting procedures, including proposed reporting formulas.

3.2.3 Acceptance of Plan

Acceptance of the contractor's plan is conditional. NWP reserves the right to require the contractor to make changes in the CQCP and operations, including removal of personnel, if necessary, to obtain the quality specified.

3.2.4 Notification of Changes

After acceptance of the CQCP, the contractor shall notify NWP in writing of any proposed change. Proposed changes are subject to acceptance by NWP.

3.3 Tests

3.3.1 Testing Procedure

The contractor shall perform specified or required tests to verify that control measures are adequate to complete the work to contract requirements. Upon request, the contractor shall furnish, at the contractor's own expense, duplicate samples of test specimens for testing by NWP. The contractor shall perform, as necessary, the following activities and permanently record the results:

- Verify that testing procedures comply with contract requirements.
- Verify that facilities and testing equipment are available and comply with testing standards.
- Check test instrument calibration data against certified standards.
- Verify that recording forms and test identification control number system, including the test documentation requirements, have been prepared.
- Record the results of tests taken, both passing and failing. Specification paragraph reference, location where tests were taken, and the sequential control number identifying the test will be given. If approved by NWP, actual test reports may be submitted later with a reference to the test number and date taken. An information copy of tests performed by an offsite or commercial test facility will be provided directly to NWP.

- The contractor may elect to develop an equipment specification with construction parameters based upon test results of a test section of ROM salt. The equipment specification based upon construction parameters shall be traceable to standard test results identified in the CQCP. Specification paragraph reference, location where construction parameters were taken, and the sequential control number identifying the construction parameters will be given. If approved by NWP, actual construction parameter reports may be submitted later with a reference to the recording of construction parameters, location, time, and date taken.

3.4 Testing Laboratory

The testing laboratory, if used, shall provide qualified personnel to perform specified sampling and testing of products in accordance with specified standards, and the requirements of contract documents.

Reports indicating results of tests, and compliance or noncompliance with the contract documents will be submitted in accordance with NWP submittal procedures. Testing by an independent firm does not relieve the contractor of the responsibility to perform the work to the contract requirements.

3.5 Inspection Services

The inspection firm shall provide qualified personnel to perform specified inspection of products in accordance with specified standards.

Reports indicating results of the inspection and compliance or noncompliance with the contract documents will be submitted in accordance with NWP submittal procedures.

Inspection by the independent firm does not relieve the contractor of the responsibility to perform the work to the contract requirements.

3.6 Completion Inspection

3.6.1 Pre-Final Inspection

At appropriate times and at the completion of the work, the contractor shall conduct an inspection of the work and develop a "punch list" of items that do not conform to the drawings and specifications. The contractor shall then notify NWP that the work is ready for inspection. NWP will perform this inspection to verify that the work is satisfactory and appropriately complete. A "final punch list" will be developed as a result of this inspection. The contractor shall ensure that the items on this list are corrected and notify NWP so that a final inspection can be scheduled. Any items noted on the final inspection shall be corrected in a timely manner. These inspections and any deficiency corrections required by this paragraph will be accomplished within the time slated for completion of the entire work.

3.6.2 Final Acceptance Inspection

The final acceptance inspection will be formally scheduled by NWP based upon notice from the contractor. This notice will be given to NWP at least 14 days prior to the final acceptance inspection. The contractor shall assure that the specific items previously identified as

unacceptable, along with the remaining work performed under the contract, will be complete and acceptable by the date scheduled for the final acceptance inspection.

3.7 Documentation

The contractor shall maintain current records providing factual evidence that required quality control activities and/or tests have been performed. These records shall include the work of subcontractors and suppliers and shall be on an acceptable form approved by NVWP.

3.8 Notification of Noncompliance

NVWP will notify the contractor of any noncompliance with the foregoing requirements. The contractor shall take immediate corrective action after receipt of such notice. Such notice, when delivered to the contractor at the worksite, shall be deemed sufficient for the purpose of notification. If the contractor fails or refuses to comply promptly, NVWP may issue an order stopping all or part of the work until satisfactory corrective action has been taken. No part of the time lost due to such stop orders shall be made the subject of claim for extension of time or for excess costs or damages by the contractor.

END OF SECTION

Section 01600 – Material and Equipment

Part 1 – General

1.1 Scope

This section includes the following:

- Equipment
- Products
- Transportation and Handling
- Storage and Protection
- Substitutions

1.2 Related Sections

- 01010 – Summary of Work
- 01400 – Contractor Quality Control
- 02010 – Mobilization and Demobilization
- 02222 – Excavation
- 03100 – Run-of-Mine Salt

1.3 Equipment

The contractor shall specify proposed equipment in the work plan. Power equipment for use underground shall be either electrical or diesel-engine driven. All diesel-engine equipment shall be certified for use underground at the Waste Isolation Pilot Plant (**WIPP**) site.

1.4 Products

The contractor shall specify in the work plan, or in subsequently required submittals, the proposed products including, but not limited to steel bulkheads and run-of-mine (**ROM**) salt. The proposed products shall be supported by laboratory test results as required by the specifications. Products shall be subject to approval by Nuclear Waste Partnership LLC (**NWP**).

1.5 Transportation and Handling

The contractor shall:

- Transport and handle products in accordance with manufacturer's instructions.
- Promptly inspect shipments to ensure that products comply with requirements, quantities are correct, and products are undamaged.
- Provide equipment and personnel to handle products by methods to prevent soiling, disfigurement, or damage.

1.6 Storage and Protection

The contractor shall:

- Store and protect products in accordance with manufacturers' instructions.
- Store with seals and labels intact and legible.
- Store sensitive products in weather-tight, climate-controlled enclosures in an environment favorable to product.
- Provide ventilation to prevent condensation and degradation of products.
- Store loose granular materials (other than ROM salt) on solid flat surfaces in a well-drained area and prevent mixing with foreign matter.
- Provide equipment and personnel to store products by methods to prevent soiling, disfigurement, or damage.
- Arrange storage of products to permit access for inspection and periodically inspect to verify products are undamaged and are maintained in acceptable condition.

1.7 Substitutions

1.7.1 Equipment Substitutions

The contractor may substitute equipment for that proposed in the work plan subject to NWP approval.

1.7.2 Product Substitutions

The contractor may not substitute products after the proposed products have been approved by NWP unless he can demonstrate that the supplier/source of that product no longer exists in which case he shall submit alternate products with lab test results to NWP for approval.

Part 2 – Products

Not used.

Part 3 – Execution

Not used.

END OF SECTION

Waste Isolation Pilot Plant
Hazardous Waste Facility Permit
Attachment G1, Appendix G1-A
October 2023

DIVISION 2 – SITE WORK

Section 02010 – Mobilization and Demobilization

Part 1 – General

1.1 Scope

This section includes the following:

- Mobilization of Equipment and Facilities to Site
- Use of Site
- Use of Existing Facilities
- Demobilization of Equipment and Facilities
- Site Cleanup

1.2 Related Sections

- 01010 – Summary of Work
- 01600 – Material and Equipment

Part 2 – Products

Not used.

Part 3 – Execution

3.1 Mobilization of Equipment and Facilities to Site

Upon authorization to proceed, the contractor shall mobilize the contractor's equipment and facilities to the jobsite. Equipment and facilities shall be as specified and as defined in the contractor's work plan.

Nuclear Waste Partnership LLC (NWP) will provide utilities at designated locations. The contractor shall be responsible for hookups and tie-ins required for contractor operations.

The contractor shall be responsible for providing its own office, storage, and sanitary facilities.

Areas will be designated for the contractor's use in the underground area near the Waste Isolation Pilot Plant (WIPP) Panel Closure (WPC) installation. These areas are limited.

3.2 Use of Site

The contractor shall use only those areas specifically designated for use by NWP. The contractor shall limit on-site travel to the specific routes required for performance of work, and designated by NWP.

3.3 Use of Existing Facilities

Existing facilities available for use by the contractor are as follows:

- Waste shaft conveyance

- Salt skip hoist
- 460-volt AC, 3-phase power
- Water underground at waste shaft only
- Water on surface at location designated by NWP

The contractor shall arrange for use of the facilities with NWP and coordinate contractor actions and requirements with ongoing NWP operations.

Use of water in the underground will be restricted. No washout or cleanup will be permitted in the underground except as designated by NWP. Aboveground washout or cleanup of equipment will be allowed in the areas designated by NWP.

The contractor is cautioned to be aware of the physical dimensions of the waste conveyance and the air lock.

The contractor shall be responsible for any damage incurred by the existing site facilities as a result of contractor operations. Any damage shall be reported immediately to NWP and repaired at the contractor's cost.

3.4 Demobilization of Equipment and Facilities

At completion of work, the contractor shall demobilize contractor equipment and facilities from the job site. Contractor's equipment and materials shall be removed and disturbed areas restored. Utilities shall be removed to their connection points unless otherwise directed by NWP. Any equipment that becomes radiologically contaminated will be managed in accordance with NWP radiological protection policies.

3.5 Site Cleanup

At conclusion of the work, the contractor shall remove trash, waste, debris, excess construction materials, and restore the affected areas to their prior condition, to the satisfaction of NWP. A final inspection will be conducted by NWP and the contractor before final payment is approved. Any trash, waste, debris, excess construction materials that become radiologically contaminated will be managed in accordance with NWP radiological protection policies.

END OF SECTION

Section 02222 – Excavation

Part 1 – General

1.1 Scope

This section includes the following:

- Excavation for Surface Preparation and Leveling of Areas for Steel Bulkhead and ROM Salt Placement
- Disposing of Excavated Materials
- Field Measurements and Survey

1.2 Related Sections

- 01010 – Summary of Work
- 01600 – Material and Equipment

1.3 Reference Documents

Krieg, R.D., 1984. Reference Stratigraphy and Rock Properties for the Waste Isolation Pilot Plant, SAND83-1908, Sandia National Laboratories, Albuquerque, New Mexico.

1.4 Field Measurements and Survey

Survey required for performance of the work will be provided by Nuclear Waste Partnership LLC (NWP).

Part 2 – Products

Not used.

Part 3 – Execution

3.1 Excavation for Surface Preparation and Leveling of Areas for Steel Bulkhead and ROM Salt Placement

The contractor shall inspect the areas designated for placement of the Waste Isolation Pilot Plant (WIPP) Panel Closure (WPC) components (run-of-mine (ROM) salt and steel bulkheads) and remove any loose material. If loose material is found, the contractor shall excavate and prepare the surface by removing loose material and cleaning rock surfaces. The surface preparation of the floor shall produce a surface suitable for anchoring the steel bulkhead base components and for placing the first layer of ROM salt (as applicable). Excavation may be performed by either mechanical or manual means. Use of explosives is prohibited.

3.2 Disposing of Excavated Materials

The contractor shall dispose of excavated materials as directed by NWP. No excavated materials from radiologically controlled areas will be disposed of without prior approval of NWP.

3.3 Field Measurements and Survey

Survey required for performance of the work will be provided by NWP. The contractor shall protect survey control points, benchmarks, etc., from damage. NWP will verify that the contractor has excavated to the required lines and grades. No salt shall be emplaced until approved by NWP.

END OF SECTION

Waste Isolation Pilot Plant
Hazardous Waste Facility Permit
Attachment G1, Appendix G1-A
October 2023

DIVISION 3 – WPC COMPONENTS

SECTION 03100 – Run-of-Mine Salt

Part 1 – General

1.1 Scope

This section includes the following:

- Salt Placement

1.2 Related Sections

- 01010 – Summary of Work
- 01400 – Contractor Quality Control
- 01600 – Material and Equipment

1.3 Submittals for Review and Approval

The salt emplacement method, dust control plan and other safety-related material shall be approved by Nuclear Waste Partnership LLC (NWP).

1.4 Quality Assurance

The contractor shall perform the work in accordance with the Contractor Quality Control Plan (CQCP).

Part 2 – Products

2.1 Salt Material

The salt is run-of-mine (ROM) salt and requires no grading or compaction. The salt shall be free of foreign organic material.

Part 3 – Execution

3.1 General

The contractor shall furnish labor, material, equipment, and tools to handle and place the salt.

The contractor shall use underground equipment and underground mine personnel as required in Part 1.5, Work by Others in Section 01010, Summary of Work. NWP will supply ROM salt. The contractor shall make suitable arrangements for transporting and placing the ROM salt.

3.2 Installation

Run-of-mine salt shall be transported to the Waste Isolation Pilot Plant (WIPP) Panel Closure (WPC)-An installation area north of Panel 9 prior to installation of the outbye bulkhead and to the WPC-B installation area north of Panel 10 after the construction of the in-by steel bulkhead. Run-of-mine salt from any underground excavation is useable as long as it is free of foreign organic matter. The ROM salt is not required to achieve a specified density.

Salt may be emplaced in layers to facilitate the construction. The ROM salt is emplaced in layers to achieve minimum lengths shown in Table 1. The lengths reported in Table 1 do not include sloped ends of the ROM salt plug. Extents of the ROM salt emplacement are designated in the drawings.

There shall be no gap left between ROM salt and roof or sidewalls. Hand placement or push plates can be used to fill the voids if necessary. The approximate lengths and slope inclines are specified in the drawings. Emplacement of the ROM salt at natural angle of repose is acceptable.

Table 1 Minimum ROM Salt Lengths

Entry Width (feet)	Minimum ROM Salt Length ¹ (feet)
14	35
16	40
20	50
25	65

Note:

1. Reported ROM length dimensions do not include end slopes of the ROM salt plug.

3.3 Field Quality Control

The contractor shall provide a Quality Control Inspector to inspect the emplacement of salt.

END OF SECTION

SECTION 03200 – Steel Bulkheads

Part 1 – General

1.1 Scope

This section includes the following:

- Steel Bulkhead Installation

1.2 Related Sections

- 01010 – Summary of Work
- 01400 – Contractor Quality Control
- 01600 – Material and Equipment

1.3 Submittals for Review and Approval

The method of installation, construction equipment, and construction materials shall be approved by Nuclear Waste Partnership LLC (NWP).

1.4 Quality Assurance

The contractor shall perform the work in accordance with the Contractor Quality Control Plan (CQCP).

Part 2 – Products

2.1 Bulkhead Material

Construction material, including steel profiles, sheet metal, flexible flashing, and connectors/bolts shall be approved by NWP prior to construction.

Part 3 – Execution

3.1 General

The contractor shall furnish all labor, material, equipment, and tools to install steel bulkheads at the locations specified in the drawings. The contractor shall use underground equipment and underground mine personnel as required in Part 1.5, Work by Others, in Section 01010, Summary of Work.

3.2 Fabrication

Bulkheads will be fabricated on the surface or in the underground in a location designated by NWP.

3.3 Installation

In-bye steel and out-bye steel bulkheads shall be installed in the designated WPC areas approved by the NWP as specified in the drawings. The contractor shall not commence installation activities without prior inspection of the ground conditions as documented in the Health and Safety Plan (**HASP**) per Section 01010 of these specifications and without prior approval by NWP.

3.4 Field Quality Control

The contractor shall provide a Quality Control Inspector to inspect the steel bulkhead installation if requested by NWP prior to contract.

3.5 Product Acceptance

The contractor shall arrange for the pre-final inspection and final product inspection as described in Part 3.6, Section 01400, of these specifications. The resolution of noncompliance issues will be conducted as described in Part 3.8, Section 01400, of these specifications.

END OF SECTION

**ATTACHMENT G1
APPENDIX G1-B**

DRAWINGS

**WIPP PANEL CLOSURE
WASTE ISOLATION PILOT PLANT
CARLSBAD, NEW MEXICO**

WIPP PANEL CLOSURE CARLSBAD, NEW MEXICO



INDEX OF DRAWINGS	
DRAWING NO.	TITLE
262-001	WIPP PANEL CLOSURE (WPC) TITLE SHEET
262-002	WPC LAYOUT
262-003	TYPICAL PANEL LAYOUT AND RELATED ENTRY CIRCUIT CONNECTIONS
262-004	WPC DETAILS - RELATED AND FROM GALT LOCATIONS
262-005	WPC DETAILS - RELATED FROM WIP AND ATTACHMENT DETAIL

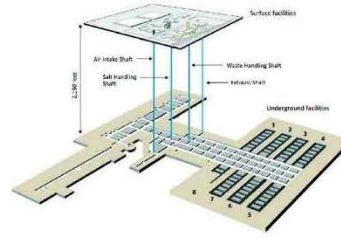

<p>CLIENT: NUCLEAR WASTE PARTNERSHIP LLC</p> <p>CONTRACT NO.: 14300000000000000000</p> <p>DATE: 08/20/2023</p> <p>PROJECT: WIPP PANEL CLOSURE (WPC) TITLE SHEET</p> <p>PROJECT NO.: 063-2213NEW</p>	<p>PROJECT: WIPP PANEL CLOSURE (WPC) TITLE SHEET</p> <p>PROJECT NO.: 063-2213NEW</p> <p>DATE: 08/20/2023</p> <p>PROJECT NO.: 063-2213NEW</p> <p>DATE: 08/20/2023</p>
<p>DESIGNED: PREPARED (REVISED) APPROVED</p> <p>DATE: 08/20/2023</p>	<p>DESIGNED: PREPARED (REVISED) APPROVED</p> <p>DATE: 08/20/2023</p>

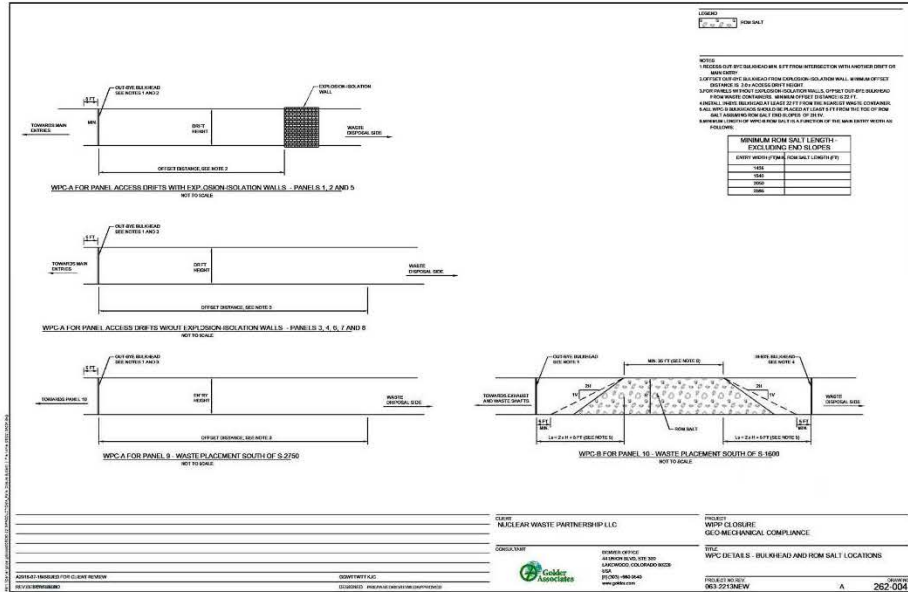

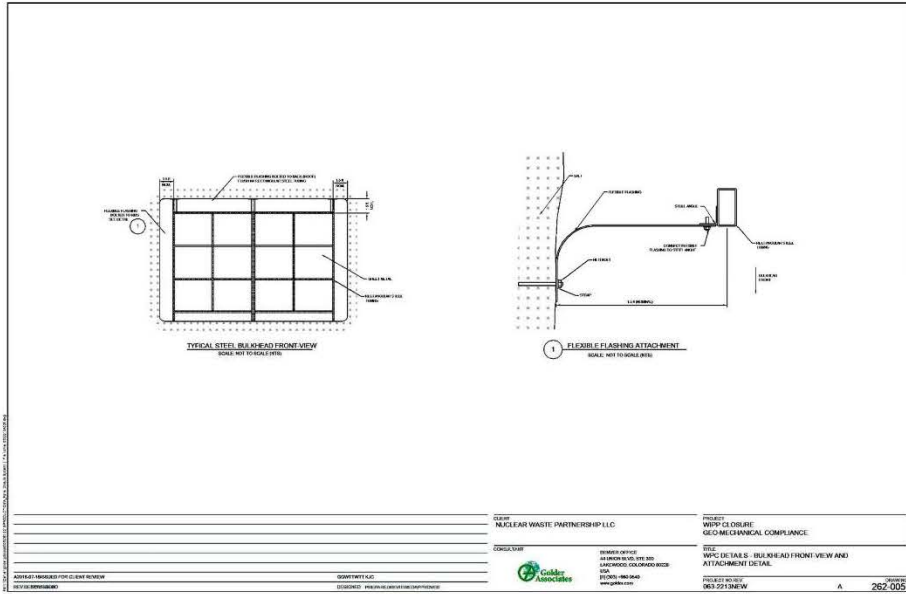

ATTACHMENT G2

**WASTE ISOLATION PILOT PLANT
SHAFT SEALING SYSTEM COMPLIANCE
SUBMITTAL DESIGN REPORT**

ATTACHMENT G2

**WASTE ISOLATION PILOT PLANT
SHAFT SEALING SYSTEM
COMPLIANCE SUBMITTAL DESIGN REPORT**

ADAPTED FROM:

**SAND96-1326/1
DISTRIBUTION UNLIMITED
RELEASE CATEGORY UC-721
PRINTED AUGUST 1996**

**WASTE ISOLATION PILOT PLANT
SHAFT SEALING SYSTEM
COMPLIANCE SUBMITTAL DESIGN REPORT**

**VOLUME 1 OF 2: MAIN REPORT
APPENDICES A AND B**

**REPOSITORY ISOLATION SYSTEMS DEPARTMENT
SANDIA NATIONAL LABORATORIES
ALBUQUERQUE, NM 87185**

Abstract

This report describes a shaft sealing system design for the Waste Isolation Pilot Plant (WIPP), a proposed nuclear waste repository in bedded salt. The system is designed to limit entry of water and release of contaminants through the four existing shafts after the WIPP is decommissioned. The design approach applies redundancy to functional elements and specifies multiple, common, low-permeability materials to reduce uncertainty in performance. The system comprises 13 elements that completely fill the shafts with engineered materials possessing high density and low permeability. Laboratory and field measurements of component properties and performance provide the basis for the design and related evaluations. Hydrologic, mechanical, thermal, and physical features of the system are evaluated in a series of calculations. These evaluations indicate that the design guidance is addressed by effectively limiting transport of fluids within the shafts, thereby limiting transport of hazardous material to regulatory boundaries. Additionally, the use or adaptation of existing technologies for placement of the seal components combined with the use of available, common materials assure that the design can be constructed.

This report was modified to make it a part of the RCRA Facility Permit issued by the New Mexico Environment Department (NMED). The modifications included removal of Appendices C and D from the original document. Although they were important to demonstrate compliance with the performance standards in the hazardous waste regulations, they do not provide plans or procedures that will be implemented under the authority of the Permit. Appendices A, B and E are retained as Attachments to the Permit (Attachments G2-A, G2-B and G2-E). The Figures

in this report, which were interspersed in the text in the original document, have been moved to a common section following the References.

Acknowledgments

The work presented in this document represents the combined effort of a number of individuals at Sandia National Laboratories, Parsons Brinckerhoff (under contract AG-4909), INTERA (under contract AG-4910), RE/SPEC (under contract AG-4911), and Tech Reps. The Sandian responsible for the preparation of each section of the report and the lead individual(s) at firms under contract to Sandia that provided technical expertise are recognized below.

Section	Author(s)
Executive Summary	F. D. Hansen, Sandia
Section 1, Introduction	J. R. Tillerson, Sandia
Section 2, Site Geologic, Hydrologic, & Geochemical Setting	A. W. Dennis and S. J. Lambert, Sandia
Section 3, Design Guidance	A. W. Dennis, Sandia
Section 4, Design Description	A. W. Dennis, Sandia
Section 5, Material Specifications	F. D. Hansen, Sandia
Section 6, Construction Techniques	E. H. Ahrens, Sandia
Section 7, Structural Analyses of Shaft Seals	L. D. Hurtado, Sandia; M. C. Loken and L.L. Van Sambeek, RE/SPEC
Section 8, Hydrologic Evaluation of the Shaft Seal System	M. K. Knowles, Sandia; V.A. Kelley, INTERA
Section 9, Conclusions	J. R. Tillerson and A. W. Dennis, Sandia
Appendix A, Material Specifications	F. D. Hansen, Sandia
Appendix B, Shaft Sealing Construction Procedures	E. H. Ahrens, Sandia, with the assistance of Parsons Brinckerhoff Construction and Scheduling staff
Appendix C, Fluid Flow Analyses	M. K. Knowles, Sandia; V.A. Kelley, INTERA
Appendix D, Structural Analyses	L. D. Hurtado, Sandia; M. C. Loken and L. L. Van Sambeek, RE/SPEC

Waste Isolation Pilot Plant
Hazardous Waste Facility Permit
Attachment G2
October 2023

Appendix E, Design Drawings

A. W. Dennis, Sandia; C. D. Mann, Parsons
Brinckerhoff, with the assistance of the
Parsons Brinckerhoff Design staff

Design reviews provided by Malcolm Gray, Atomic Energy Canada Ltd., Whiteshell Laboratory; Stephen Phillips, Phillips Mining, Geotechnical & Grouting, Inc.; and John Tinucci, Itasca Consulting Group, Inc. are appreciated, as are document reviews provided by Don Galbraith, U.S. Department of Energy Carlsbad Area Office; William Thompson, Carlsbad Area Office Technical Assistance Contractor; Robert Stinebaugh, Palmer Vaughn, Deborah Coffey, and Wendell Weart, Sandia.

T. P. Peterson and S. B. Kmetz, Tech Reps, served as technical editors of this document.

TABLE OF CONTENTS

Executive Summary.....	10
Introduction.....	10
Site Setting.....	10
Design Guidance.....	10
Design Description.....	11
Structural Analysis.....	12
Hydrologic Evaluations.....	14
Concluding Remarks.....	16
1. Introduction.....	16
1.1 Purpose of Compliance Submittal Design Report.....	16
1.2 WIPP Description.....	16
1.3 Performance Objective for WIPP Shaft Seal System.....	17
1.4 Sealing System Design Development Process.....	17
1.5 Organization of Document.....	18
1.6 Systems of Measurement.....	19
2. Site Geologic, Hydrologic, and Geochemical Setting.....	20
2.1 Introduction.....	20
2.2 Site Geologic Setting.....	20
2.2.1 Regional WIPP Geology and Stratigraphy.....	20
2.2.2 Local WIPP Stratigraphy.....	21
2.2.3 Rock Mechanics Setting.....	21
2.3 Site Hydrologic Setting.....	22
2.3.1 Hydrostratigraphy.....	22
2.3.2 Observed Vertical Gradients.....	26
2.4 Site Geochemical Setting.....	27
2.4.1 Regional and Local Geochemistry in Rustler Formation and Shallower Units.....	27
2.4.2 Regional and Local Geochemistry in the Salado Formation.....	29
3. Design Guidance.....	32
3.1 Introduction.....	32
3.2 Design Guidance and Design Approach.....	32
4. Design Description.....	34
4.1 Introduction.....	34
4.2 Existing Shafts.....	34
4.3 Sealing System Design Description.....	38
4.3.1 Salado Seals.....	39
4.3.1.1 Compacted Salt Column.....	39
4.3.1.2 Upper and Lower Salado Compacted Clay Columns.....	40
4.3.1.3 Upper, Middle, and Lower Concrete-Asphalt Waterstops.....	41
4.3.1.4 Asphalt Column.....	41
4.3.1.5 Shaft Station Monolith.....	42
4.3.2 Rustler Seals.....	42
4.3.2.1 Rustler Compacted Clay Column.....	42

	4.3.2.2	Rustler Concrete Plug	43
4.3.3		Near-Surface Seals	43
	4.3.3.1	Near-Surface Upper Compacted Earthen Fill	43
	4.3.3.2	Near-Surface Concrete Plug	43
	4.3.3.3	Near-Surface Lower Compacted Earthen Fill	44
5.		Material Specification	45
5.1		Longevity	46
5.2		Materials	47
	5.2.1	Mass Concrete	47
	5.2.2	Compacted Clay	48
	5.2.3	Asphalt	48
	5.2.4	Compacted Salt Column	49
	5.2.5	Cementitious Grout	50
	5.2.6	Earthen Fill	51
5.3		Concluding Remarks	51
6.		Construction Techniques	52
6.1		Multi-Deck Stage	52
6.2		Salado Mass Concrete (Shaft Station Monolith and Shaft Plugs)	52
6.3		Compacted Clay Columns (Salado and Rustler Formations)	53
6.4		Asphalt Waterstops and Asphaltic Mix Columns	53
6.5		Compacted WIPP Salt	53
6.6		Grouting of Shaft Walls and Removal of Liners	54
6.7		Earthen Fill	55
6.8		Schedule	55
7.		Structural Analyses of Shaft Seals	56
7.1		Introduction	56
7.2		Analysis Methods	56
7.3		Models of Shaft Seals Features	56
	7.3.1	Seal Material Models	57
	7.3.2	Intact Rock Lithologies	57
	7.3.3	Disturbed Rock Zone Models	57
7.4		Structural Analyses of Shaft Seal Components	57
	7.4.1	Salado Mass Concrete Seals	57
	7.4.1.1	Thermal Analysis of Concrete Seals	58
	7.4.1.2	Structural Analysis of Concrete Seals	58
	7.4.1.3	Thermal Stress Analysis of Concrete Seals	58
	7.4.1.4	Effect of Dynamic Compaction on Concrete Seals	59
	7.4.1.5	Effect of Clay Swelling Pressures on Concrete Seals	59
	7.4.2	Crushed Salt Seals	59
	7.4.2.1	Structural Analysis of Compacted Salt Seal	59
	7.4.2.2	Pore Pressure Effects on Reconsolidation of Crushed Salt Seals	59
	7.4.3	Compacted Clay Seals	60
	7.4.4	Asphalt Seals	60
	7.4.4.1	Thermal Analysis	60
	7.4.4.2	Structural Analysis	60

	7.4.4.3	Shrinkage Analysis	61
7.5		Disturbed Rock Zone Considerations	61
	7.5.1	General Discussion of DRZ	61
	7.5.2	Structural Analyses	61
	7.5.2.1	Salado Salt	61
	7.5.2.2	Salado Anhydrite Beds	62
	7.5.2.3	Near-Surface and Rustler Formations	62
7.6		Other Analyses	62
	7.6.1	Asphalt Waterstops	62
	7.6.2	Shaft Pillar Backfilling	63
8.		Hydrologic Evaluation of the Shaft Seal System	64
	8.1	Introduction	64
	8.2	Performance Models	64
	8.3	Downward Migration of Rustler Groundwater	64
	8.3.1	Analysis Method	65
	8.3.2	Summary of Results	65
	8.4	Gas Migration and Consolidation of Compacted Salt Column	66
	8.4.1	Analysis Method	67
	8.4.2	Summary of Results	67
	8.5	Upward Migration of Brine	69
	8.6	Intra-Rustler Flow	69
9.		Conclusions	70
10.		References	72
Appendix G2-A		Material Specifications	
Appendix G2-B		Shaft Sealing Construction Procedures	
Appendix C*		Fluid Flow Analyses	
Appendix D*		Structural Analyses	
Appendix G2-E		Design Drawings	

* Appendices C and D are not included in the facility Permit.

***FIGURES**

Figure	Title
Figure G2-1	View of the WIPP Underground Facility
Figure G2-2	Location of the WIPP in the Delaware Basin
Figure G2-3	Chart Showing Major Stratigraphic Divisions, Southeastern New Mexico
Figure G2-4	Generalized Stratigraphy of the WIPP Site Showing Repository Level
Figure G2-5	Arrangement of the Air Intake Shaft Sealing System
Figure G2-6	Multi-deck Stage Illustrating Dynamic Compaction
Figure G2-7	Multi-deck Stage Illustrating Excavation for Asphalt Waterstop
Figure G2-8	Drop Pattern for 6-m-Diameter Shaft Using a 1.2-m-Diameter Tamper
Figure G2-9	Plan and Section Views of Downward Spin Pattern of Grout Holes
Figure G2-10	Plan and Section Views of Upward Spin Pattern of Grout Holes
Figure G2-11	Example of Calculation of an Effective Salt Column Permeability from the Depth-Dependent Permeability at a Point in Time
Figure G2-12	Effective Permeability of the Compacted Salt Column using the 95% Certainty Line

*NOTE: All Figures are attached following References

TABLES

Table	Title
Table G2-1	Salado Brine Seepage Intervals ⁽¹⁾
Table G2-2	Permeability and Thickness of Hydrostratigraphic Units in Contact with Seals
Table G2-3	Freshwater Head Estimates in the Vicinity of the Air Intake Shaft
Table G2-4	Chemical Formulas, Distributions, and Relative Abundance of Minerals in the Rustler and Salado Formations (after Lambert, 1992)
Table G2-5	Major Solutes in Selected Representative Groundwater from the Rustler Formation and Dewey Lake Redbeds, in mg/L (after Lambert, 1992)
Table G2-6	Variations in Major Solutes in Brines from the Salado Formation, in mg/L (after Lambert, 1992)
Table G2-7	Shaft Sealing System Design Guidance
Table G2-8	Drawings Showing Configuration of Existing WIPP Shafts (Drawings are in Appendix G2-E)
Table G2-9	Summary of Information Describing Existing WIPP Shafts
Table G2-10	Drawings Showing the Sealing System for Each Shaft (Drawings are in Appendix G2-E)
Table G2-11	Drawings Showing the Shaft Station Monoliths (Drawings are in Appendix G2-E)
Table G2-12	Summary of Results from Performance Model

ACRONYMS

AIS	Air Intake Shaft
AMM	asphalt mastic mix
CFR	Code of Federal Regulations
DOE	Department of Energy
DRZ	disturbed rock zone
EPA	Environmental Protection Agency
HMAC	hot mix asphalt concrete
MDCF	Multimechanism Deformation Coupled Fracture
MD	Munson-Dawson
NMED	New Mexico Environment Department
NMVP	No Migration Variance Petition
PA	performance assessment
PTM	Plug Test Matrix
QA	quality assurance
SMC	Salado Mass Concrete
SPVD	Site Preliminary Design Validation
SSSPT	Small Scale Seal Performance Test
SWCF	Sandia WIPP Central Files
TRU	transuranic
WIPP	Waste Isolation Pilot Plant

Executive Summary

Introduction

This report documents a shaft seal system design developed as part of a submittal to the Environmental Protection Agency (EPA) and the New Mexico Environment Department (NMED) that will demonstrate regulatory compliance of the Waste Isolation Pilot Plant (WIPP) for disposal of transuranic waste. The shaft seal system limits entry of water into the repository and restricts the release of contaminants. Shaft seals address fluid transport paths through the opening itself, along the interface between the seal material and the host rock, and within the disturbed rock surrounding the opening. The entire shaft seal system is described in this Permit Attachment and its three appendices, which include seal material specifications, construction methods, rock mechanics analyses, fluid flow evaluations, and the design drawings. The design represents a culmination of several years of effort that has most recently focused on providing to the EPA and NMED a viable shaft seal system design. Sections of this report and the appendices explore function and performance of the WIPP shaft seal system and provide well documented assurance that such a shaft seal system could be constructed using available materials and methods. The purpose of the shaft seal system is to limit fluid flow within four existing shafts after the repository is decommissioned. Such a seal system would not be implemented for several decades, but to establish that regulatory compliance can be achieved at that future date, a shaft seal system has been designed that exhibits excellent durability and performance and is constructable using existing technology. The design approach is conservative, applying redundancy to functional elements and specifying various common, low-permeability materials to reduce uncertainty in performance. It is recognized that changes in the design described here will occur before construction and that this design is not the only possible combination of materials and construction strategies that would adequately limit fluid flow within the shafts.

Site Setting

One of the U.S. Department of Energy's (DOE's) site selection criteria is a favorable geologic setting which minimizes fluid flow as a transport mechanism. Groundwater hydrology in the proximity of the WIPP site is characterized by geologic strata with low transmissivity and low hydrologic gradients, both very positive features with regard to sealing shafts. For purposes of performance evaluations, hydrological analyses divide lithologies and requirements into the Rustler Formation (and overlying strata) and the Salado Formation, comprised mostly of salt. The principal design concern is fluid transport phenomena of seal materials and lithologies within the Salado Formation. The rock mechanics setting is an important consideration in terms of system performance. Rock properties affect hydrologic response of the shaft seal system. The stratigraphic section contains lithologies that exhibit brittle and ductile behavior. A zone of rock around the shafts is disturbed owing to the creation of the opening. The disturbed rock zone (DRZ) is an important design consideration because it possesses higher permeability than intact rock. Host rock response and its potential to fracture, flow, and heal around WIPP shaft openings are relevant to the performance of the shaft seal system.

Design Guidance

Use of both engineered and natural barriers to isolate wastes from the accessible environment is required by 20.4.1.500 NMAC (incorporating 40 CFR §§264.111 and 264.601) and 40 CFR §191.14(d). The use of engineered barriers to prevent or substantially delay movement of water,

hazardous constituents, or radionuclides toward the accessible environment is required by 20.4.1.500 NMAC (incorporating 40 CFR §§264.111 and 264.601) and 40 CFR §194.44. Hazardous constituent release performance standards are specified in Permit Part 5 and 20.4.1.500 NMAC (incorporating 40 CFR §§264.111(b), 264.601(a), and 264 Subpart F). Radionuclide release limits are specified in 40 CFR §191 for the entire repository system (EPA, 1996a; 1996b). Design guidance for the shaft seal system addresses the need for the WIPP to comply with system requirements and to follow accepted engineering practices using demonstrated technology. Design guidance is categorized below:

- limit hazardous constituents reaching regulatory boundaries,
- restrict groundwater flow through the sealing system,
- use materials possessing mechanical and chemical compatibility,
- protect against structural failure of system components,
- limit subsidence and prevent accidental entry, and
- utilize available construction methods and materials.

Discussions of the design presented in the text of this report and the details presented in the appendices respond to these qualitative design guidelines. The shaft seal system design was completed under a Quality Assurance program that includes review by independent, qualified experts to assure the best possible information is provided to the DOE on selection of engineered barriers (40 CFR §194.27). Technical reviewers examined the complete design including conceptual, mathematical, and numerical models and computer codes (40 CFR §194.26). The design reduces the impact of uncertainty associated with any particular element by using multiple sealing system components and by using components constructed from different materials.

Design Description

The shaft sealing system comprises 13 elements that completely fill the shaft with engineered materials possessing high density and low permeability. Salado Formation components provide the primary regulatory barrier by limiting fluid transport along the shaft during and beyond the 10,000-year regulatory period. Components within the Rustler Formation limit commingling between brine-bearing members, as required by state regulations. Components from the Rustler to the surface fill the shaft with common materials of high density, consistent with good engineering practice. A synopsis of each component is given below.

Shaft Station Monolith. At the bottom of each shaft a salt-saturated concrete monolith supports the local roof. A salt-saturated concrete, called Salado Mass Concrete (**SMC**), is specified and is placed using a conventional slickline construction procedure where the concrete is batched at the surface. SMC has been tailored to match site conditions. The salt-handling shaft and the waste-handling shaft have sumps which also will be filled with salt-saturated concrete as part of the monolith.

Clay Columns. A sodium bentonite is used for three compacted clay components in the Salado and Rustler Formations. Although alternative construction specifications are viable, labor-intensive placement of compressed blocks is specified because of proven performance. Clay columns effectively limit brine movement from the time they are placed to beyond the 10,000-year regulatory period. Stiffness of the clay is sufficient to promote healing of fractures in the surrounding rock salt near the bottom of the shafts, thus removing the proximal DRZ as a

potential pathway. The Rustler clay column limits brine communication between the Magenta and Culebra Members of the Rustler Formation.

Concrete-Asphalt Waterstop Components. Concrete-asphalt waterstop components comprise three elements: an upper concrete plug, a central asphalt waterstop, and a lower concrete plug. Three such components are located within the Salado Formation. These concrete-asphalt waterstop components provide independent shaft cross-section and DRZ seals that limit fluid transport, either downward or upward. Concrete fills irregularities in the shaft wall, while use of the salt-saturated concrete assures good bonding with salt. Salt creep against the rigid concrete components establishes a compressive stress state and promotes early healing of the salt DRZ surrounding the concrete plugs. The asphalt intersects the shaft cross section and the DRZ.

Compacted Salt Column. Each shaft seal includes a column of compacted WIPP salt with 1.5 percent weight water added to the natural material. Construction demonstrations have shown that mine-run WIPP salt can be dynamically compacted to a density equivalent to approximately 90% of the average density of intact Salado salt. The remaining void space is removed through consolidation caused by creep closure. The salt column becomes less permeable as density increases. The location of the compacted salt column near the bottom of the shaft assures the fastest achievable consolidation of the compacted salt column after closure of the repository. Analyses indicate that the salt column becomes an effective long-term barrier in under 100 years.

Asphalt Column. An asphalt-aggregate mixture is specified for the asphalt column, which bridges the Rustler/Salado contact and provides a seal essentially impermeable to brine for the shaft cross-section and the shaft wall interface. All asphalt is placed with a heated slickline.

Concrete Plugs. A concrete plug is located just above the asphalt column and keyed into the surrounding rock. Mass concrete is separated from the cooling asphalt column with a layer of fibercrete, which permits work to begin on the overlying clay column before the asphalt has completely cooled. Another concrete plug is located near the surface, extending downward from the top of the Dewey Lake Redbeds.

Earthen Fill. The upper shaft is filled with locally available earthen fill. Most of the fill is dynamically compacted (the same method used to construct the salt column) to a density approximating the surrounding lithologies. The uppermost earthen fill is compacted with a sheepsfoot roller or vibratory plate compactor.

Structural Analysis

Structural issues pertaining to the shaft seal system have been evaluated. Mechanical, thermal, physical, and hydrological features of the system are included in a broad suite of structural calculations. Conventional structural mechanics applications would normally calculate load on system elements and compare the loads to failure criteria. Several such conventional calculations have been performed and show that the seal elements exist in a favorable, compressive stress state that is low in comparison to the strength of the seal materials. Thermal analyses have been performed to examine the effects of concrete heat of hydration and heat transfer for asphalt elements. Coupling between damaged rock and fluid flow and between the density and permeability of the consolidating salt column is evaluated within the scope of structural calculations. The appendices provide descriptions of various structural calculations

conducted as part of the design study. The purpose of each calculation varies; however, the calculations generally address one or more of the following concerns: (1) stability of the component, (2) influences of the component on hydrological properties of the seal and surrounding rock, or (3) construction methods. Stability calculations address:

- potential for thermal cracking of concrete;
- structural loads on seal components resulting from salt creep, gravity, swelling clay, dynamic compaction, or possible repository-generated gas pressures.

Structural calculations defining input conditions to hydrological calculations include:

- spatial extent of the DRZ within the Salado Formation salt beds as a function of depth, time, and seal material;
- fracturing and DRZ development within Salado Formation interbeds;
- shaft-closure induced consolidation of compacted salt columns; and
- impact of pore pressures on salt consolidation.

Construction analyses examine:

- placement and structural performance of asphalt waterstops, and
- potential subsidence reduction through backfilling the shaft station areas.

Structural calculations model shaft features including representation of the host rock and its damaged zone as well as the seal materials themselves. Two important structural calculations discussed below are unique to shaft seal applications.

DRZ Behavior. The development and subsequent healing of a DRZ that forms in the rock mass surrounding the WIPP shafts is a significant concern in the seal design. It is well known that a DRZ will develop in rock salt adjacent to the shaft upon excavation. Placement of rigid components in the shaft promotes healing within the salt DRZ as seal elements restrain inward creep and reduce the stress difference. Two computer models to calculate development and extent of the salt DRZ are used. The first model uses a ratio of stress invariants to predict fracture; the second approach uses a damage stress criterion. The temporal and spatial extent of the DRZ along the entire shaft length is evaluated. Several analyses are performed to examine DRZ behavior of the rock salt surrounding the shaft. The time-dependent DRZ development and subsequent healing in the Salado salt surrounding each of the four seal materials are considered. All seal materials below a depth of about 300 m provide sufficient rigidity to heal the DRZ, a phenomenon that occurs quickly around rigid components near the shaft bottom. An extensive calculation is made of construction effects on the DRZ during placement of the asphalt-concrete waterstops. The time-dependent development of the DRZ within anhydrite and polyhalite interbeds of the Salado Formation is calculated. For all interbeds, the factor of safety against shear or tensile fracturing increases with depth into the rock surrounding the shaft wall. These results indicate that a continuous DRZ will not develop in nonsalt Salado rocks. Rock mechanics analysis also determines which of the near surface

lithologies fracture in the proximity of the shaft. Results from these rock mechanics analyses are used as input conditions for the fluid-flow analyses.

Compacted Salt Behavior. Unique application of crushed salt as a seal component required development of a constitutive model for salt reconsolidation. The model developed includes a nonlinear elastic component and a creep consolidation component. The nonlinear elastic modulus is density-dependent, based on laboratory test data performed on WIPP crushed salt. Creep consolidation behavior of crushed salt is based on three candidate models whose parameters are obtained from model fitting to hydrostatic and shear consolidation test data gathered for WIPP crushed salt. The model for consolidating crushed salt is used to predict permeability of the salt column. The seal system prevents fluid transport to the consolidating salt column to ensure that pore pressure does not unacceptably inhibit the reconsolidation process. Calculations made to estimate fractional density of the crushed salt seal as a function of time, depth, and pore pressure show consolidation time increases as pore pressure increases, as expected. At a constant pore pressure of one atmosphere, compacted salt will increase from its initial fractional density of 90% to 96% within 40, 80, and 120 years after placement at the bottom, middle, and top of the salt component, respectively. At a fractional density of 96%, the permeability of reconsolidating salt is approximately 10^{-18} m². A pore pressure of 2 MPa increases times required to achieve a fractional density of 96% to 92 years, 205 years, and 560 years at the bottom, middle, and top of the crushed salt column, respectively. A pore pressure of 4 MPa would effectively prevent reconsolidation of the crushed salt within 1,000 years. Fluid flow calculations show only minimal transport of fluids to the salt column, so pore pressure equilibrium in the consolidating salt does not occur before low permeabilities ($\sim 10^{-18}$ m²) are achieved.

Hydrologic Evaluations

The ability of the shaft seal system to satisfy design guidance is determined by the performance of the actual seal components within the physical setting in which they are constructed. Important elements of the physical setting are hydraulic gradients of the region, properties of the lithologic units surrounding a given seal component, and potential gas generation within the repository. Hydrologic evaluations focus on processes that could result in fluid flow through the shaft seal system and the ability of the seal system to limit any such flow. Transport of radiological or hazardous constituents will be limited if the carrier fluids are similarly limited. Physical processes that could impact seal system performance have been incorporated into four models. These models evaluate: (1) downward migration of groundwater from the Rustler Formation, (2) gas migration and reconsolidation of the crushed salt seal component, (3) upward migration of brines from the repository, and (4) flow between water-bearing zones in the Rustler Formation.

Downward Migration of Rustler Groundwater. The shaft seal system is designed to limit groundwater flowing into and through the shaft sealing system. The principal source of groundwater to the seal system is the Culebra Member of the Rustler Formation. No significant sources of groundwater exist within the Salado Formation; however, brine seepage has been noted at a number of the marker beds and is included in the models. Downward migration of Rustler groundwater is limited to ensure that liquid saturation of the compacted salt column does not impact the consolidation process and to limit quantities of brine reaching the repository horizon. Consolidation of the compacted salt column will be most rapid immediately following seal construction. Simulations conducted for the 200-year period following closure demonstrate that, during this initial period, downward migration of Rustler groundwater is insufficient to

impact the consolidation process. Rock mechanics analyses show that this period encompasses the reconsolidation process. Lateral migration of brine through the marker beds is quantified in the analysis and shown to be inconsequential. At steady-state, the flow rate is most dependent on permeability of the system. Potential flow paths within the seal system consist of the seal material, an interface with the surrounding rock, and the host rock DRZ. Low permeability is specified for the engineered materials, and construction methods ensure a tight interface. Thus the flow path most likely to impact performance is the DRZ. Effects of the DRZ and sensitivity of the seal system performance to both engineered and host rock barriers show that the DRZ is successfully mitigated by the proposed design.

Gas Migration and Salt Column Consolidation. A multi-phase flow model of the lower seal system evaluates the performance of components extending from the middle concrete-asphalt waterstop located at the top of the salt column to the repository horizon for 200 years following closure. During this time period, the principal fluid sources to the model consist of potential gas generated by the waste and lateral brine migration within the Salado Formation. The predicted downward migration of a small quantity of Rustler groundwater (discussed above) is included in this analysis. Effects of gas generation are evaluated for three different repository repressurization scenarios, which simulate pressures as high as 14 MPa. Model results predict that high repository pressures do not produce appreciable differences in the volume of gas migration over the 200-year simulation period. Relatively low gas flow is a result of the low permeability and rapid healing of the DRZ around the lower concrete-asphalt waterstop.

Upward Migration of Brine. The Salado Formation is overpressurized with respect to the measured heads in the Rustler, and upward migration of contaminated brines could occur through an inadequately sealed shaft. Results from the model discussed above demonstrate that the crushed salt seal will reconsolidate to a very low permeability within 100 years following repository closure. Structural results show that the DRZ surrounding the long-term clay and crushed salt seal components will completely heal within the first several decades. Model calculations predict that very little brine flows from the repository to the Rustler/Salado contact.

Intra-Rustler Flow. Based on head differences between the various members of the Rustler Formation, nonhydrostatic conditions exist within the Rustler Formation. Therefore, the potential exists for vertical flow within water-bearing strata within the Rustler. The two units with the greatest transmissivity within the Rustler are the Culebra and the Magenta dolomites, which have the greatest potential for interflow. The relatively low undisturbed permeabilities of the mudstone and anhydrite units separating the Culebra and the Magenta naturally limit crossflow. However, the construction and subsequent closure of the shaft provide a potentially permeable vertical conduit connecting water-bearing units. The primary motivation for limiting formation crossflow within the Rustler is to prevent mixing of formation waters within the Rustler, as required by State of New Mexico statute. Commonly, such an undertaking would limit migration of higher dissolved solids (high-density) groundwater into lower dissolved solids groundwater. In the vicinity of the WIPP site, the Culebra has a higher density groundwater than the Magenta, and the potential for fluid migration between the two most transmissive units is from the unit with the lower total dissolved solids to the unit with the higher dissolved solids. This calculation shows that potential flow rates between the Culebra and the Magenta are insignificant. Under expected conditions, intra-Rustler flow is expected to be of such a limited quantity that (1) it will not affect either the hydraulic or chemical regime within the Culebra or the Magenta and (2) it will not be detrimental to the seal system itself.

Concluding Remarks

The principal conclusion is that an effective, implementable shaft seal system has been designed for the WIPP. Design guidance is addressed by limiting any transport of fluids within the shaft, thereby limiting transport of hazardous material to regulatory boundaries. The application or adaptation of existing technologies for placement of seal components combined with the use of available, common materials provide confidence that the design can be constructed. The structural setting for seal elements is compressive, with shear stresses well below the strength of seal materials. Because of the favorable hydrologic regime coupled with the low intrinsic permeability of seal materials, long-term stability of the shaft seal system is expected. Credibility of these conclusions is bolstered by the basic design approach of using multiple components to perform each sealing function and by using extensive lengths within the shafts to effect a sealing system. The shaft seal system adequately meets design requirements and can be constructed.

1. Introduction

1.1 Purpose of Compliance Submittal Design Report

This report documents the detailed design of the shaft sealing system for the Waste Isolation Pilot Plant (WIPP). The design documented in this report builds on the concepts and preliminary evaluations presented in the Sealing System Design Report issued in 1995 (DOE, 1995). The report contains a detailed description of the design and associated construction procedures, material specifications, analyses of structural and fluid flow performance, and design drawings. The design documented in this report forms the basis for the shaft sealing system which will be constructed under the authority of the hazardous waste facility Permit issued by NMED and as required by 20.4.1.500 NMAC (incorporating 40 CFR §§264.111(b) and 264.601(a)).

1.2 WIPP Description

The WIPP is designed as a full-scale, mined geological repository for the safe management, storage, and disposal of transuranic (TRU) radioactive wastes and TRU mixed wastes generated by US government defense programs. The facility is located near Carlsbad, New Mexico, in the southeastern portion of the state. The underground facility (Figure G2-1) consists of a series of shafts, drifts, panels, and disposal rooms. Four shafts, ranging in diameter from 3.5 to 6.1 m, connect the disposal horizon to the surface. Sealing of these four shafts is the focus of this report.

The disposal horizon is at a depth of approximately 655 m in bedded halite within the Salado Formation. The Salado is a sequence of bedded evaporites approximately 600 m thick that were deposited during the Permian Period, which ended about 225 million years ago. Salado salt has been identified as a good geologic medium to host a nuclear waste repository because of several favorable characteristics. The characteristics present at the WIPP site include very low permeability, vertical and lateral stratigraphic extent, tectonic stability, and the ability of salt to creep and ultimately entomb material placed in excavated openings. Creep closure also plays an important role in the shaft sealing strategy.

The WIPP facility must be determined to be in compliance with applicable regulations prior to the disposal of waste. After the facility meets the regulatory requirements, disposal rooms will be filled with containers holding TRU wastes of various forms. Wastes placed in the drifts and

disposal rooms will be at least 150 m from the shafts. Regulatory requirements include use of both engineered and natural barriers to limit migration of hazardous constituents from the repository to the accessible environment. The shaft seals are part of the engineered barriers.

1.3 Performance Objective for WIPP Shaft Seal System

Each of the four shafts from the surface to the underground repository must be sealed to limit hazardous material release to the accessible environment and to limit groundwater flow into the repository. Although the seals will be permanent, the regulatory period applicable to the repository system analyses is 10,000 years.

1.4 Sealing System Design Development Process

This report presents a conservative approach to shaft sealing system design. Shaft sealing system performance plays a crucial role in meeting regulatory radionuclide and hazardous constituents release requirements. Although all engineering materials have uncertainties in properties, a combination of available, low-permeability materials can provide an effective sealing system. To reduce the impact of system uncertainties and to provide a high level of assurance of compliance, numerous components are used in this sealing system. Components in this design include long columns of clay, densely compacted crushed salt, a waterstop of asphaltic material sandwiched between massive low-permeability concrete plugs, a column of asphalt, and a column of earthen fill. Different materials perform identical functions within the design, thereby adding confidence in the system performance through redundancy.

The design is based on common materials and construction methods that utilize available technologies. When choosing materials, emphasis was given to permeability characteristics and mechanical properties of seal materials. However, the system is also chemically and physically compatible with the host formations, enhancing long-term performance.

Recent laboratory experiments, construction demonstrations, and field test results have been added to the broad and credible database and have supported advances in modeling capability. Results from a series of multi-year, in situ, small-scale seal performance tests show that bentonite and concrete seals maintain very low permeabilities and show no deleterious effects in the WIPP environment. A large-scale dynamic compaction demonstration established that crushed salt can be successfully compacted. Laboratory tests show that compacted crushed salt consolidates through creep closure of the shaft from initial conditions achieved in dynamic compaction to a dense salt mass with regions where permeability approaches that of in situ salt. These technological advances have allowed more credible analysis of the shaft sealing system.

The design was developed through an interactive process involving a design team consisting of technical specialists in the design and construction of underground facilities, materials behavior, rock mechanics analysis, and fluid flow analysis. The design team included specialists drawn from the staff of Sandia National Laboratories, Parsons Brinckerhoff Quade and Douglas, Inc. (contract number AG-4909), INTERA, Inc. (contract number AG-4910), and RE/SPEC Inc. (contract number AG-4911), with management by Sandia National Laboratories. The contractors developed a quality assurance program consistent with the Sandia National Laboratories Quality Assurance Program Description for the WIPP project. All three contractors received quality assurance support visits and were audited through the Sandia National Laboratories audit and assessment program. Quality assurance (QA) documentation is maintained in the Sandia National Laboratories WIPP Central Files. Access to project files for

each contractor can be accomplished using the contract numbers specified above. In addition to the contractor support, technical input was obtained from consultants in various technical specialty areas.

Formal preliminary and final design reviews have been conducted on the technical information documented in the report. In addition, technical, management, and QA reviews have been performed on this report. Documentation is in the WIPP Central File.

It is recognized that additional information, such as on specific seal material or formation characteristics, on the sensitivity of system performance to component properties, on placement effectiveness, and on long-term performance, could be used to simplify the design and perhaps reduce the length or number of components. Such design optimization and associated simplifications are left to future research that may be used to update the compliance evaluations completed between now and the time of actual seal emplacement.

1.5 Organization of Document

This report contains an Executive Summary, 10 sections, and 5 appendices. The body of the report does not generally contain detailed backup information; this information is incorporated by reference or in the appendices.

The Executive Summary is a synopsis of the design and the supporting discussions related to seal materials, construction procedures, structural analyses, and fluid flow analyses. Introductory material in Section 1 sets the stage for and provides a "road map" to the remainder of the report.

Site characteristics that detail the setting into which the seals would be placed are documented in Section 2. These characteristics include the WIPP geology and stratigraphy for both the region and the shafts as well as a brief discussion of rock mechanics considerations of the site that impact the sealing system. Regional and local characteristics of the hydrologic and geochemical settings are also briefly discussed.

Section 3 presents the design guidance used for development of the shaft sealing system design. Seal-related guidance from applicable regulations is briefly described. The design guidance is then provided along with the design approach used to implement the guidance. The guidance forms the basis both for the design and for evaluations of the sealing system presented in other sections.

The shaft sealing system is documented in Section 4; detailed drawings for the design are provided in Appendix G2-E. The seal components, their design, and their functions are discussed for the Salado, the Rustler, and the overlying formations.

The sealing materials are described briefly in Section 5, with more detail provided in the materials specifications (Appendix G2-A). The materials used in the various seal components are discussed along with the reasons they are expected to function as intended. Material properties including permeability, strength, and mechanical constitutive response are given for each material. Brief discussions of expected compatibility, performance, construction techniques, and other characteristics relevant to the WIPP setting are also given.

Section 6 contains a brief description of the construction techniques proposed for use. General site and sealing preparation activities are discussed, including construction of a multi-deck stage for use throughout the placement of the components. Construction procedures to be used for the various types of components are then summarized based on the more detailed discussions provided in Appendix G2-B.

Section 7 summarizes structural analyses performed to assess the ability of the shaft sealing system to function in accordance with the design guidance provided in Section 3 and to provide input to hydrological calculations. The methods and computer programs, the models used to simulate the behavior of the seal materials and surrounding salt, and the results of the analyses are discussed. Particular emphasis is placed on the evaluations of the behavior of the disturbed rock zone. Details of the structural analyses are presented in Appendix D of *Waste Isolation Pilot Plant Shaft Sealing System Compliance Submittal Design Report ("Compliance Submittal Design Report")* (Sandia, 1996). Section 8 summarizes fluid flow analyses performed to assess the ability of the shaft sealing system to function in accordance with the design guidance provided in Section 3. Hydrologic evaluations are focused on processes that could result in fluid flow through the shaft seal system and the ability of the seal system to limit such flow. Processes evaluated are downward migration of groundwater from the overlying formation, gas migration and reconsolidation of the crushed salt component, upward migration of brines from the repository, and flow between water-bearing zones in the overlying formation. Hydrologic models are described and the results are discussed as they relate to satisfying the design guidance, with extensive reference to Appendix C of the Compliance Submittal Design Report (Sandia, 1996) that documents details of the flow analyses. Conclusions drawn about the performance of the WIPP shaft sealing system are described in Section 9. The principal conclusion that an effective, implementable design has been presented is based on the presentations in the previous sections. A reference list that documents principal references used in developing this design is then provided.

The three appendices that follow provide details related to the following subjects:

- Appendix G2-A — Material Specification
- Appendix G2-B — Shaft Sealing Construction Procedures
- Appendix G2-E — Design Drawings (separate volume)

1.6 Systems of Measurement

Two systems of measurement are used in this document and its appendices. Both the System International d'Unites (SI) and English Gravitational (*fps* units) system are used. This usage corresponds to common practice in the United States, where SI units are used for scientific studies and *fps* units are used for facility design, construction materials, codes, and standards. Dual dimensioning is used in the design description and other areas where this use will aid the reader.

2. Site Geologic, Hydrologic, and Geochemical Setting

The site characteristics relevant to the sealing system are discussed in this section. The location and geologic setting of the WIPP are discussed first to provide background. The geology and stratigraphy, which affect the shafts, are then discussed. The hydrologic and geochemical settings, which influence the seals, are described last.

2.1 Introduction

The WIPP site is located in an area of semiarid rangeland in southeastern New Mexico. The nearest major population center is Carlsbad, 42 km west of the WIPP. Two smaller communities, Loving and Malaga, are about 33 km to the southwest. Population density close to the WIPP is very low: fewer than 30 permanent residents live within a 16-km radius.

2.2 Site Geologic Setting

Geologically the WIPP is located in the Delaware Basin, an elongated depression that extends from just north of Carlsbad southward into Texas. The Delaware Basin is bounded by the Capitan Reef (see Figure G2-2). The basin covers over 33,000 km² and is filled with sedimentary rocks to depths of 7,300 m (Hills, 1984). Rock units of the Delaware Basin (representing the Permian System through the Quaternary System) are listed in Figure G2-3.

Minimal tectonic activity has occurred in the region since the Permian Period (Powers et al., 1978). Faulting during the late Tertiary Period formed the Guadalupe and Delaware Mountains along the western edge of the basin. The most recent igneous activity in the area occurred during the mid-Tertiary Period about 35 million years ago and is evidenced by a dike in the subsurface 16 km northwest of the WIPP. Major volcanic activity last occurred more than 1 billion years ago during Precambrian time (Powers et al., 1978). None of these processes affected the Salado Formation at the WIPP. Therefore, seismic-related design criteria are not included in the current seal systems design guidelines.

2.2.1 Regional WIPP Geology and Stratigraphy

The Delaware Basin began forming with crustal subsidence during the Pennsylvanian Period approximately 300 million years ago. Relatively rapid subsidence over a period of about 14 million years resulted in the deposition of a sequence of deep-water sandstones, shales, and limestones rimmed by shallow-water limestone reefs such as the Capitan Reef (see Figure G2-2). Subsidence slowed during the late Permian Period. Evaporite deposits of the Castile Formation and the Salado Formation (which hosts the WIPP underground workings) filled the basin and extended over the reef margins. The evaporites, carbonates, and clastic rocks of the Rustler Formation and the Dewey Lake Redbeds were deposited above the Salado Formation near the end of the Permian Period. The Santa Rosa and Gatuña Formations were deposited after the close of the Permian Period.

From the surface downward to the repository horizon the stratigraphic units are the Quaternary surface sand sediments, Gatuña Formation, Santa Rosa Formation, Dewey Lake Redbeds, Rustler Formation, and Salado Formation. Three principal stratigraphic units (the Dewey Lake Redbeds, the Rustler Formation, and the Salado Formation) comprise all but the upper 15 to 30 m (50 to 100 ft) of the geologic section above the WIPP facility.

The Dewey Lake Redbeds consist of alternating layers of reddish-brown, fine-grained sandstone and siltstone cemented with calcite and gypsum (Vine, 1963). The Rustler Formation lies below the Dewey Lake Redbeds; this formation, the youngest of the Late Permian evaporite sequence, includes units that provide potential pathways for radionuclide migration from the WIPP. The five units of the Rustler, from youngest to oldest, are: (1) the Forty-niner Member, (2) the Magenta Dolomite Member, (3) the Tamarisk Member, (4) the Culebra Dolomite Member, and (5) an unnamed lower member.

The 250-million-year-old Salado Formation lies below the Rustler Formation. This unit is about 600 m thick and consists of three informal members. From youngest to oldest, they are: (1) an upper member (unnamed) composed of reddish-orange to brown halite interbedded with polyhalite, anhydrite, and sandstone, (2) a middle member (the McNutt Potash Zone) composed of reddish-orange and brown halite with deposits of sylvite and langbeinite; and (3) a lower member (unnamed) composed of mostly halite with lesser amounts of anhydrite, polyhalite, and glauberite, with some layers of fine clastic material. These lithologic layers are nearly horizontal at the WIPP, with a regional dip of less than one degree. The WIPP repository is located in the unnamed lower member of the Salado Formation, approximately 655 m (2150 ft) below the ground surface.

2.2.2 Local WIPP Stratigraphy

The generalized stratigraphy of the WIPP site, with the location of the repository, is shown in Figure G2-4. To establish the geologic framework required for the design of the WIPP facility shaft sealing system, an evaluation was performed to assess the geologic conditions existing in and between the shafts, where the individual shaft sealing systems will eventually be emplaced (DOE, 1995: Appendix G2-A). The study evaluated shaft stratigraphy, regional groundwater occurrence, brine occurrence in the exposed Salado Formation section, and the consistency between recorded data and actual field data.

Four shafts connect the WIPP underground workings to the surface, the (1) Air Intake Shaft (AIS), (2) Exhaust Shaft, (3) Salt Handling Shaft, and (4) Waste Shaft. Stratigraphic correlation and evaluation of the unit contacts show that lithologic units occur at approximately the same levels in all four shaft locations. Some stratigraphic contact elevations vary because of regional structure and stratigraphic thinning and thickening of units. However, the majority of the stratigraphic contacts used to date are suitable for engineering design reference because they intersect all four shafts.

2.2.3 Rock Mechanics Setting

The WIPP stratigraphy includes rock types that exhibit both brittle and ductile behaviors. The majority of the stratigraphy intercepted by the shafts consists of the Salado Formation, which is predominantly halite. The primary mechanical behavior of halitic rocks is creep. Except near free surfaces (such as the shaft wall), the salt rocks will remain tight and undisturbed despite the long-term creep deformation they sustain. The other rock types within the Salado Formation are anhydrites and polyhalites. These two rock types are typically brittle, stiff, and exhibit high strength in laboratory tests. The structural strength of particular anhydritic rock layers, however, depends on the thickness of the layers, which range from thin (<1 m) to fairly thick (10 m or more). Brittle failure of these noncreeping rocks can occur as they restrain, or attempt to restrain, the creep of the salt above and below the stiff layer. Although thick layers can resist the

induced stresses, thin layers are fractured in tension by the salt creep. Because the deformation in the bounding salt is time dependent, the damage in the brittle rock is also time dependent.

Above the Salado Formation, the Rustler Formation stratigraphy consists of relatively strong limestones and siltstones. The shaft excavation is the only significant disturbance to these rocks. Any subsurface subsidence (deformation) or loading induced by the presence of the repository are negligible in a rock mechanics sense.

Regardless of rock type, the shafts create a disturbed zone in the surrounding rock. Microfracturing will occur in the rock adjacent to the shaft wall, where confining stresses are low or nonexistent. The extent of the zone depends on the rock strength and the prevailing stress state, which is depth dependent. In the salt rocks, microfracturing occurs to form the disturbed zone both at the time of excavation and later as dilatant creep deformations occur. In the brittle rocks, the disturbance occurs at the time of excavation and does not worsen with time. The extent of disturbed zones in the salt and brittle rocks can be calculated, as will be described in Section 7 and Appendix D in the Compliance Submittal Design Report (Sandia, 1996).

Preventing the salt surrounding the shafts from creeping causes reintroduction of stresses that reverse the damage process and cause healing (Van Sambeek et al., 1993). The seal system design relies on this principle for sealing the disturbed zone in salt. In the brittle rocks, grouting of the damage is a viable means of reducing the interconnected fractures that increase the permeability of the rock.

2.3 Site Hydrologic Setting

The WIPP shafts penetrate approximately 655 m (2150 ft) of sediments and rocks. From a hydrogeologic perspective, relevant information includes the permeability of the water-bearing units, the thickness of the water-bearing units, and the observed vertical pressure (head) gradients expected to exist after shaft construction and ambient pressure recovery. This section will discuss these three aspects of the site hydrogeology. The geochemistry of the pore fluids adjacent to the shaft system is also important hydrogeologic information and will be provided in Section 2.4.

2.3.1 Hydrostratigraphy

The WIPP shafts penetrate Quaternary surface sediments, the Gatuña Formation, the Santa Rosa Formation, the Dewey Lake Redbeds, the Rustler Formation, and the Salado Formation. The Rustler Formation contains the only laterally-persistent water-bearing units in the WIPP vicinity. As a result, flow-field characterization, regional flow-modeling, and performance assessment off-site release scenarios focus on the Rustler Formation. The hydrogeology of the stratigraphic units in contact with the upper portion of the AIS sealing system is fairly well known from detailed hydraulic testing of the Rustler Formation at well H-16 located 17 m from the AIS (Beauheim, 1987). The H-16 borehole was drilled in July and August 1987 to monitor the hydraulic responses of the Rustler members to the drilling and construction of the AIS. During the drilling of H-16, each member of the Rustler Formation was cored. In addition, detailed drill-stem, pulse, and slug hydraulic tests were performed in H-16 on the members of the Rustler. Through the detailed testing program at H-16, the permeability of each of the Rustler members was estimated. Detailed mapping of the AIS by Holt and Powers (1990) and other investigators provided information on the location of wet zones and weeps within the Salado Formation. This

information will be summarized below. The reader, unless particularly interested in this subject, should proceed to Section 2.3.2.

Water-bearing zones have been observed in units above the Rustler Formation in the WIPP site vicinity. However, drilling in the Dewey Lake Redbeds has not identified any continuous saturated units at the WIPP site. Water-bearing units within stratigraphic intervals above the Rustler are typically perched saturated zones of very low yield. Thin perched groundwater intervals have been encountered in WIPP wells H-1, H-2, and H-3 (Mercer and Orr, 1979). The only Dewey Lake Redbed wells that have sufficient yields for watering livestock are the James Ranch wells, the Pocket well, and the Fairfield well (Brinster, 1991). These wells are located to the south of the WIPP and are not in the immediate vicinity of the WIPP shafts.

The Dewey Lake Redbeds overlie the Rustler Formation. The Rustler is composed of five members defined by lithology. These are, in ascending order, the unnamed lower member, the Culebra dolomite, the Tamarisk, the Magenta dolomite, and the Forty-niner (see Figure G2-4). Of these five members, the unnamed lower member, the Culebra, and the Magenta are the most transmissive units in the Rustler. The Tamarisk and the Forty-niner are aquitards within the Rustler and have very low permeabilities relative to the three members listed above.

To the east of the shafts in Nash Draw, the Rustler/Salado contact has been observed to be permeable and water-bearing. This contact unit has been referred to as the "brine aquifer" (Mercer, 1983). The brine aquifer is not reported to exist in the vicinity of the shafts. The hydraulic conductivity of the Rustler/Salado contact in the vicinity of the shafts is reported to be approximately 4×10^{-11} m/s, which is equivalent to a permeability of 6×10^{-18} m² using reference brine fluid properties (Brinster, 1991). The unnamed lower member was hydraulic tested at well H-16 in close proximity to the AIS. The maximum permeability of the unnamed lower member was interpreted to be 2.2×10^{-18} m² and was attributed to the unnamed lower member claystone by Beauheim (1987), which correlates to the transition and bioturbated clastic zones of Holt and Powers (1990).

The Culebra Dolomite Member is the most transmissive member of the Rustler Formation in the vicinity of the WIPP site and is the most transmissive saturated unit in contact with the shaft sealing system. The Culebra is an argillaceous dolomicrite which contains secondary porosity in the form of abundant vugs and fractures. The permeability of the Culebra varies greatly in the vicinity of the WIPP and is controlled by the condition of the secondary porosity (fractures). The permeability of the Culebra in the vicinity of the shafts is approximately 2.1×10^{-14} m².

The Tamarisk Member is composed primarily of massive, lithified anhydrite, including anhydrite 2, mudstone 3, and anhydrite 3. Testing of the Tamarisk at H-16 was unsuccessful. The estimated transmissivity of the Tamarisk at H-16 is one to two orders of magnitude lower than the least-transmissive unit successfully tested at H-16, which results in a permeability range from 4.6×10^{-20} to 4.6×10^{-19} m². Anhydrites in the Rustler have an approximate permeability of 1×10^{-19} m². The permeability of mudstone 3 is 1.5×10^{-19} m² (Brinster, 1991).

The Magenta is a dolomite that is typically less permeable than the Culebra. The Magenta Dolomite Member overlies the Tamarisk Member. The Magenta is an indurated, gypsiferous, arenaceous, dolomite that Holt and Powers (1990) classify as a dolarenite. The dolomite grains are primarily composed of silt to fine sand-sized clasts. Wavy to lenticular bedding and ripple cross laminae are prevalent through most of the Magenta. Holt and Powers (1990) estimate that

inflow to the shaft from the Magenta during shaft mapping was less than 1 gal/min. The Magenta has a permeability of approximately $1.5 \times 10^{-15} \text{ m}^2$ (Saulnier and Avis, 1988).

The Forty-niner Member is divided into three informal lithologic units. The lowest unit is anhydrite 4, a laminated anhydrite having a gradational contact with the underlying Magenta. Mudstone 4 overlies anhydrite 4 and is composed of multiple units containing mudstones, siltstones, and very fine sandstones. Anhydrite 5 is the uppermost informal lithologic unit of the Forty-niner Member. The permeability of mudstone 4, determined from the pressure responses in the Forty-niner interval of H-16 to the drilling of the AIS, is $3.9 \times 10^{-16} \text{ m}^2$ (referred to as the Forty-niner claystone by Avis and Saulnier, 1990).

The Salado Formation is a very low permeability formation that is composed of bedded halite, polyhalite, anhydrite, and mudstones. Inflows in the shafts have been observed over select intervals during shaft mapping, but flows are below the threshold of quantification. In some cases these weeps are individual, lithologically distinct marker beds, and in some cases they are not. Directly observable brine flow from the Salado Formation into excavated openings is a short-lived process. Table G2-1 lists the brine seepage intervals identified by Holt and Powers (1990) during their detailed mapping of the AIS. Seepage could be indicated by a wet rockface or by the presence of precipitate from brine evaporation on the shaft rockface. The zones listed in Table G2-1 make up less than 10% of the Salado section that is intersected by the WIPP shafts.

Table G2-1
Salado Brine Seepage Intervals⁽¹⁾

Stratigraphic Unit	Lithology	Thickness (m)
Marker Bed 103	Anhydrite	5.0
Marker Bed 109	Anhydrite	7.7
Vaca Triste	Mudstone	2.4
Zone A	Halite	2.9
Marker Bed 121	Polyhalite	0.5
Union Anhydrite	Anhydrite	2.3
Marker Bed 124	Anhydrite	2.7
Zone B	Halite	0.9
Zone C	Halite	2.7
Zone D	Halite	3.2
Zone E	Halite	0.6
Zone F	Halite	0.9
Zone G	Halite	0.6
Zone H	Halite	1.8
Marker Bed 129	Polyhalite	0.5
Zone I	Halite	1.7
Zone J	Halite	1.2

⁽¹⁾ After US DOE, 1995.

To gain perspective into the important stratigraphic units from a hydrogeologic view, the permeability and thickness of the units adjacent to the shafts can be compared. Table G2-2 lists the lithologic units in the Rustler and the Salado Formations with their best estimate permeabilities and their thickness as determined from the AIS mapping. The stratigraphy of the units overlying the Rustler is not considered in Table G2-2 because these units are typically not saturated in the vicinity of the WIPP shafts. The overlying sediments account for approximately 25% of the stratigraphy column adjacent to the shafts.

Because permeability varies over several orders of magnitude, the log of the permeability is also listed to simplify comparison between units. Table G2-2 shows that by far the two most transmissive zones occur in the Rustler Formation; these are the Culebra and Magenta dolomites. These units are relatively thin when compared to the combined Rustler and Salado thickness adjacent to the shafts (3% of Rustler and Salado combined thickness). The Magenta and the Culebra are the only two units that are known to possess permeabilities higher than $1 \times 10^{-18} \text{ m}^2$.

**Table G2-2
 Permeability and Thickness of Hydrostratigraphic Units in Contact with Seals**

Formation	Member/Lithology	Undisturbed Permeability (m^2)	Thickness (m)
Rustler	Anhydrite ⁽¹⁾	1.0×10^{-19}	46.7
Rustler	Mudstone 4	3.9×10^{-18}	4.4
Rustler	Magenta	1.5×10^{-15}	7.8
Rustler	Mudstone 3	1.5×10^{-19}	2.9
Rustler	Culebra	2.1×10^{-14}	8.9
Rustler	Transition/ Bioturbated Clastics	2.2×10^{-18}	18.7
Salado	Halite	1.0×10^{-21}	356.6
Salado	Polyhalite	3.0×10^{-21}	10.9
Salado	Anhydrite	1.0×10^{-19}	28.2

⁽¹⁾ Anhydrite 5, Anhydrite 4, Anhydrite 3, and Anhydrite 2

The vast majority (97%) of the rocks adjacent to the shaft in the Rustler and the Salado Formations are low permeability ($<1 \times 10^{-18} \text{ m}^2$). The conclusion that can be drawn from reviewing Table G2-2 is that the shafts are located hydrogeologically in a low permeability, low groundwater flow regime. Inflow measurements have historically been made at the shafts, and observable flow is attributed to leakage from the Rustler Formation.

Flow modeling of the Culebra has demonstrated that depressurization has occurred as a result of the sinking of the shafts at the site. Maximum estimated head drawdown in the Culebra at the centroid of the shafts was estimated by Haug et al. (1987) to be 33 m in the mid-1980s. This drawdown in the permeable units intersected by the shafts is expected because the shafts act as long-term constant pressure (atmospheric) sinks. Measurements of fluid flow into the WIPP shafts when they were unlined show a range from a maximum of 0.11 L/s (3,469 m^3/yr) measured in the Salt Handling Shaft on September 13, 1981 to a minimum of 0.008 L/s (252 m^3/yr) measured at the Waste Handling Shaft on August 6, 1987 (LaVenue et al., 1990).

The following summary of shaft inflow rates from the Rustler is based on a review of LaVenue et al. (1990) and Cauffman et al. (1990). Shortly after excavation and prior to grouting and liner installation, the inflow into the Salt Handling Shaft was 0.11 L/s (3,469 m³/yr). The average flow rate measured after shaft lining for the period from mid-1982 through October 1992 was 0.027 L/s (851 m³/yr). The average flow rate into the Waste Handling Shaft during the time when the shaft was open and unlined was about 0.027 L/s (851 m³/yr). Between the first and second grouting events (July 1984 to November 1987) the average inflow rate was 0.016 L/s (505 m³/yr). No estimates were found after the second grouting. Inflow to the pilot holes for the Exhaust Shaft averaged 0.028 L/s (883 m³/yr). In December 1984 a liner plate was grouted across the Culebra. After this time, a single measurement of inflow from the Culebra was 0.022 L/s (694 m³/yr). After liner plate installation, three separate grouting events occurred at the Culebra. No measurable flow was reported after the third grouting event in the summer of 1987. Flow into the AIS when it was unlined and draining averaged 0.044 L/s (1,388 m³/yr). Since the Rustler has been lined, flow into the AIS has been negligible.

The majority of the flow represented by these shaft measurements originates from the Rustler. This is clearly evident by the fact that lining of the WIPP shafts was found to be unnecessary in the Salado Formation below the Rustler/Salado contact. When the liners were installed, flow rates diminished greatly. Under sealed conditions, hydraulic gradients in rocks adjacent to the shaft will diminish as the far-field pressures approach ambient conditions. The low-permeability materials sealing the shaft combined with the reduction in lateral hydraulic gradients will likely result in flow rates into the shaft that are several orders of magnitude less than observed under open shaft or lined shaft conditions.

2.3.2 Observed Vertical Gradients

Hydraulic heads within the Rustler and between the Rustler and Salado Formations are not in hydrostatic equilibrium. Mercer (1983) recognized that heads at the Rustler Salado transition (referred to as the brine aquifer and not present in the vicinity of the WIPP shafts) indicate an upward hydraulic gradient from that zone to the Culebra. Later, with the availability of more head measurements within the Salado and Rustler members, Beauheim (1987) provided additional insight into the potential direction of vertical fluid movement within the Rustler. He reported that the hydraulic data indicate an upward gradient from the Salado to the Rustler.

Formation pressures in the Salado Formation have been decreased in the near vicinity of the WIPP underground facility. The highest, and thought to be least disturbed, estimated formation fluid pressure from hydraulic testing is 12.55 MPa estimated from interpretation of testing within borehole SCP01 in Marker Bed 139 (**MB139**) just below the underground facility horizon (Beauheim et al., 1993). The fresh-water head within MB139, based on the estimated static formation pressure of 12.55 MPa, is 1,663.6 m (5,458 ft) above mean sea level (msl).

Hydraulic heads in the Rustler have also been impacted by the presence of the WIPP shafts. Impacts in the Culebra were significant in the 1980s with a large drawdown cone extending away from the shafts in the Culebra (Haug et al., 1987). The undisturbed head of the Rustler Salado contact in the vicinity of the AIS is estimated to be about 936.0 m (3,071 ft) msl (Brinster, 1991). The undisturbed head in the Culebra is estimated to be approximately 926.9 m (3,041 ft) msl in the vicinity of the AIS (LaVenue et al., 1990). The undisturbed head in the Magenta is estimated to be approximately 960.1 m (3,150 ft) msl (Brinster, 1991).

The disturbed and undisturbed heads in the Rustler are summarized in Table G2-3. Also included is the freshwater head of MB139 based on hydraulic testing in the WIPP underground. Consistent with the vertical flow directions proposed by previous investigators, estimated vertical gradients in the vicinity of the AIS before the shafts were drilled indicate a hydraulic gradient from the Magenta to the Culebra and from the Rustler/Salado contact to the Culebra. There is also the potential for flow from the Salado Formation to the Rustler Formation.

**Table G2-3
Freshwater Head Estimates in the Vicinity of the Air Intake Shaft**

Hydrologic Unit	Freshwater Head (m asl)		Reference
	Undisturbed	Disturbed	
Magenta Member	960.1 ¹	948.8 ² (H-16)	Brinster (1991) Beauheim (1987)
Culebra Member	926.9 ¹	915.0 ² (H-16)	LaVenué et al. (1990) Beauheim (1987)
Lower Unnamed Member	—	953.4 ² (H-16)	Beauheim (1987)
Rustler/Salado Contact	936.0 - 940.0 ¹	—	Brinster (1991)
Salado MB139	1,663.6 ²	—	Beauheim et al. (1993)

¹ Estimated from a contoured head surface plot based principally on well data collected prior to shaft construction.

² Measured through hydraulic testing and/or long-term monitoring.

2.4 Site Geochemical Setting

2.4.1 Regional and Local Geochemistry in Rustler Formation and Shallower Units

The Rustler Formation, overlying the Salado Formation, consists of interbedded anhydrite/gypsum, mudstone/siltstone, halite east of the WIPP site, and two layers of dolomite. Principal occurrences of NaCl/MgSO₄ brackish to briny groundwater in the Rustler at the WIPP site and to the north, west, and south are found (1) at the lower member near its contact with the underlying Salado and (2) in the two dolomite members having a variable fracture-induced secondary porosity. The mineralogy of the Rustler Formation is summarized in Table G2-4.

The five members of the Rustler Formation are described as follows: (1) The Forty-niner Member is similar in lithology to the other non-dolomitic units but contains halite east of the WIPP site. (2) The Magenta Member is another variably fractured dolomite/sulfate unit containing sporadic occurrences of groundwater near and west of the WIPP site. (3) The Tamarisk Member is dominantly anhydrite (locally altered to gypsum) with subordinate fine-grained clastics, containing halite to the east of the WIPP site. (4) The Culebra Dolomite Member is dominantly dolomite with subordinate anhydrite and/or gypsum, having a variable fracture-induced secondary porosity containing regionally continuous occurrences of groundwater at the WIPP site and to the north, west, and south. (5) An unnamed lower member consists of sandstone, siltstone, mudstone, claystone, and anhydrite locally altered to gypsum, and containing halite under most of the WIPP site and occurrences of brine at its base, mostly west of the WIPP site.

Table G2-4
Chemical Formulas, Distributions, and Relative Abundance of Minerals in the Rustler and Salado Formations (after Lambert, 1992)

Mineral	Formula	Occurrence/Abundance
Amesite	$(Mg_4Al_2)(Si_2Al_2)O_{10}(OH)_3$	S, R
Anhydrite	$CaSO_4$	SSS, RRR
Calcite	$CaCO_3$	S, RR
Carnallite	$KMgCl_3 \cdot 6H_2O$	SS†
Chlorite	$(Mg,Al,Fe)_{12}(Si,Al)_8O_{20}(OH)_{16}$	S‡, R‡
Corrensite	Mixed-layer chlorite/smectite	S‡, R‡
Dolomite	$CaMg(CO_3)_2$	RR
Feldspar	$(K,Na,Ca)(Si,Al)_4O_8$	S‡, R‡
Glauberite	$Na_2Ca(SO_4)_2$	S
Gypsum	$CaSO_4 \cdot 2H_2O$	S, RRR
Halite	$NaCl$	SSS, RRR
Illite	$K_{1-1.5}Al_4(Si_{7-6.5}Al_{1-1.5}O_{20})(OH)_4$	S‡, R‡
Kainite	$KMgClSO_4 \cdot 3H_2O$	SS†
Kieserite	$MgSO_4 \cdot H_2O$	SS†
Langbeinite	$K_2Mg_2(SO_4)_3$	S*
Magnesite	$MgCO_3$	S, R
Polyhalite	$K_2Ca_2Mg(SO_4)_4 \cdot 2H_2O$	SS, R
Pyrite	FeS_2	S, R
Quartz	SiO_2	S‡, R‡
Serpentine	$Mg_3Si_2O_5(OH)_4$	S‡, R‡
Smectite	$(Ca_{1/2},Na)_{0.7}(Al,Mg,Fe)_4(Si,Al)_8O_{20}(OH)_4 \cdot nH_2O$	S‡, R‡
Sylvite	KCl	SS*

Key to Occurrence/Abundance notations:

S = Salado Formation; R = Rustler Formation; 3× = abundant, 2× = common, 1× = rare or accessory; * = potash-ore mineral (never near surface); † = potash-zone non-ore mineral; ‡ = in claystone interbeds.

The Dewey Lake Redbeds, overlying the Rustler Formation, are the uppermost Permian unit; they consist of siltstones and claystones locally transected by concordant and discordant fractures that may contain gypsum. The Dewey Lake Redbeds contain sporadic occurrences of groundwater that may be locally perched, mostly in the area south of the WIPP site. The Triassic Dockum Group (undivided) rests on the Dewey Lake Redbeds in the eastern half of the WIPP site and thickens eastward; it is a locally important source of groundwater for agricultural and domestic use.

The Gatuña Formation, overlying the Dewey Lake Redbeds, occurs locally as channel and alluvial pond deposits (sands, gravels, and boulder conglomerates). The pedogenic Mescalero caliche is commonly developed on top of the Gatuña Formation and on many other erosionally

truncated rock types. Surficial dune sand, which may be intermittently damp, covers virtually all outcrops at and near the WIPP site. Siliceous alluvial deposits southwest of the WIPP site also contain potable water. The geochemistry of groundwater found in the Rustler Formation and Dewey Lake Redbeds is summarized in Table G2-5.

**Table G2-5
Major Solutes in Selected Representative Groundwater from the Rustler Formation and Dewey Lake Redbeds, in mg/L (after Lambert, 1992)**

Well	Date	Zone	Ca	Mg	Na	K	SO ₄	Cl
WIPP-30	July 1980	R/S	955	2770	121,000	2180	7390	192,000
WIPP-29	July 1980	R/S	1080	2320	36,100	1480	12,000	58,000
H-5B	June 1981	Cul	1710	2140	52,400	1290	7360	89,500
H-9B	November 1985	Cul	590	37	146	7	1900	194
H-2A	April 1986	Cul	743	167	3570	94	2980	5310
P-17	March 1986	Cul	1620	1460	28,300	782	6020	48,200
WIPP-29	December 1985	Cul	413	6500	94,900	23,300	20,000	179,000
H-3B1	July 1985	Mag	1000	292	1520	35	2310	3360
H-4C	November 1986	Mag	651	411	7110	85	7100	8460
Ranch	June 1986	DL	420	202	200	4	1100	418

Key to Zone:

R/S = "basal brine aquifer" near the contact between the Rustler and Salado Formations; Cul = Culebra Member, Rustler Formation; Mag = Magenta Member, Rustler Formation; DL = Dewey Lake Redbeds.

2.4.2 Regional and Local Geochemistry in the Salado Formation

The Salado Formation consists dominantly of halite, interrupted at intervals of meters to tens of meters by beds of anhydrite, polyhalite, mudstone, and local potash mineralization (sylvite or langbeinite, with or without accessory carnallite, kieserite, kainite and glauberite, all in a halite matrix). Some uniquely identifiable non-halite units, 0.1 to 10 m thick, have been numbered from the top down (100 to 144) for convenience as marker beds to facilitate cross-basinal stratigraphic correlation. The WIPP facility was excavated just above Marker Bed 139 in the Salado Formation at a depth of about 655 m.

Although the most common Delaware Basin evaporite mineral is halite, the presence of less soluble interbeds (dominantly anhydrite, polyhalite, and claystone) and more soluble admixtures (e.g. sylvite, glauberite, kainite) has resulted in chemical and physical properties significantly different from those of pure NaCl. Under differential stress produced near excavations, brittle interbeds (anhydrite, polyhalite, magnesite, dolomite) may fracture, whereas under a similar stress regime pure NaCl would undergo plastic deformation. Fracturing of these interbeds has locally enhanced the permeability, allowing otherwise nonporous rock to carry groundwater (e.g., the fractured polyhalitic anhydrite of Marker Bed 139 under the floor of the WIPP excavations).

Groundwater in evaporites represents the exposure of chemical precipitates to fluids that may be agents (as in the case of dissolution) or consequences of postdepositional alteration of the

evaporites (as in the cases of dehydration of gypsum and diagenetic dewatering of other minerals). Early in the geological studies of the WIPP site, groundwater occurrences that could be hydrologically characterized were identified.

Since the beginning of conventional mining in the Delaware Basin, relatively short-lived seeps (pools on the floor, efflorescences on the walls, and stalactitic deposits on the ceiling) have been known to occur in the Salado Formation where excavations have penetrated. These brine occurrences are commonly associated with the non-halitic interbeds whose porosity is governed either by fracturing (as in brittle beds) or mineralogical discontinuities (as in "clay" seams).

The geochemistry of brines encountered in the Salado Formation is summarized in Table G2-6. The relative abundance of minerals was summarized in Table G2-4.

Table G2-6
Variations in Major Solutes in Brines from the Salado Formation, in mg/L
(after Lambert, 1992)

Source of Brine	Date	Ca	Mg	K	Na	Cl	SO ₄
Room G Seep	Sep-87	278	14800	15800	99000	188000	29500
	Nov-87	300	18700	15400	97100	190000	32000
	Feb-88	260	18200	17100	94100	186000	36200
	Mar-88	280	17000	16200	92100	187000	34800
	Jul-88	292	13000	14800	96600	188000	29300
	Sep-88	273	14700	13700	86500	185000	28000
	Apr-91	240	14400	12900	95000	189000	28000
	Jul-91	239	14100	13100	93000	190000	27700
	Oct-91	252	14700	14100	95000	189000	27100
Marker Bed 139 (under repository)		300	18900	14800	67700	155900	14700
		300	17100	15600	72700	158900	13400
		300	17600	15800	71600	182200	14700
Room J		230	17700	13500	63600	167000	15100
		210	27400	22400	56400	168000	19600
		220	17900	15600	73400	165000	9300
		250	22200	18300	63000	165000	31100
		190	31000	19900	46800	170000	24600
		100	35400	27800	40200	173000	30000
		270	18900	14500	59900	166000	16200
		280	20200	17000	70400	165000	10600
Room Q		279	31500	22600	68000	205000	19400
		288	31100	24100	68000	203000	19200
		257	34000	26300	63000	205000	23500
AIS Sump (accumulation in bottom of sump)	Jul-88	960	1040	1720	118000	187000	6170
	May-89	900	500	600	83100	122700	7700
	May-89	1000	800	1100	82400	114200	8800
McNutt Potash Zone							
Duval mine		640	55400	30000	27500	236500	3650
Miss. Chem. mine		200	44200	45800	43600	226200	12050

3. Design Guidance

3.1 Introduction

The WIPP is subject to regulatory requirements contained in applicable portions of the New Mexico Hazardous Waste Act, specifically 20.4.1.500 NMAC and .900 (incorporating 40 CFR §264 and §270), and requirements contained in 40 CFR §191 and 40 CFR §194. The use of both engineered and natural barriers to isolate wastes from the accessible environment is required by 20.4.1.500 NMAC (incorporating 40 CFR §§264.111 and 264.601) and 40 CFR §191.14(d). The use of engineered barriers to prevent or substantially delay the movement of water, hazardous constituents, or radionuclides toward the accessible environment is required by 20.4.1.500 NMAC (incorporating 40 CFR §§264.111 and 264.601) and 40 CFR §194.44. Hazardous constituent release performance standards are specified in Permit Part 5 and 20.4.1.500 NMAC (incorporating 40 CFR §§264.111(b), 264.601(a), and 264 Subpart F). Quantitative requirements for potential releases of radioactive materials from the repository system are specified in 40 CFR §191. The regulations impose quantitative release requirements on the total repository system, not on individual subsystems of the repository system, for example, the shaft sealing subsystem.

3.2 Design Guidance and Design Approach

The guidance described for the design of the shaft sealing system addresses the need for the WIPP to comply with system requirements and to follow accepted engineering practices using demonstrated technology. The design guidance addresses the need to limit:

1. radiological or other hazardous constituents reaching the regulatory boundaries,
2. groundwater flow into and through the sealing system,
3. chemical and mechanical incompatibility,
4. structural failure of system components,
5. subsidence and accidental entry, and
6. development of new construction technologies and/or materials.

For each element of design guidance, a design approach has been developed. Table G2-7 contains qualitative design guidance and the design approach used to implement it.

**Table G2-7
 Shaft Sealing System Design Guidance**

Qualitative Design Guidance	Design Approach
<i>The shaft sealing system shall limit:</i>	<i>The shaft sealing system shall be designed to meet the qualitative design guidance in the following ways:</i>
1. the migration of radiological or other hazardous constituents from the repository horizon to the regulatory boundary during the 10,000-year regulatory period following closure;	1. In the absence of human intrusion, brine migrating from the repository horizon to the Rustler Formation must pass through a low permeability sealing system.
2. groundwater flowing into and through the shaft sealing system;	2. In the absence of human intrusion, groundwater migrating from the Rustler Formation to the repository horizon must pass through a low permeability sealing system.
3. chemical and mechanical incompatibility of seal materials with the seal environment;	3. Brine contact with seal elements is limited and materials possess acceptable mechanical properties.
4. the possibility for structural failure of individual components of the sealing system;	4. State of stress from forces expected from rock creep and other mechanical loads is favorable for seal materials.
5. subsidence of the ground surface in the vicinity of the shafts and the possibility of accidental entry after sealing;	5. The shaft is completely filled with low-porosity materials, and construction equipment would be needed to gain entry.
6. the need to develop new technologies or materials for construction of the shaft sealing system.	6. Construction of the shaft sealing system is feasible using available technologies and materials.

4. Design Description

4.1 Introduction

The design presented in this section was developed based on (1) the design guidance outlined in Section 3.0, (2) past design experience, and (3) a desire to reduce uncertainties associated with the performance of the WIPP sealing system. The WIPP shaft sealing system design has evolved over the past decade from the initial concepts presented by Stormont (1984) to the design concepts presented in this document. The past designs are:

- the plugging and sealing program for the WIPP (Stormont, 1984),
- the initial reference seal system design (Nowak et al., 1990),
- the seal design alternative study (Van Sambeek et al., 1993),
- the WIPP sealing system design (DOE, 1995).

The present design changes were implemented to take advantage of knowledge gained from small-scale seals tests conducted at the WIPP (Knowles and Howard, 1996), advances in the ability to predict the time-dependent mechanical behavior of compacted salt rock (Callahan et al., 1996), large-scale dynamic salt compaction tests and associated laboratory determination of the permeability of compacted salt samples (Hansen and Ahrens, 1996; Brodsky et al., 1996), field tests to measure the permeability of the DRZ surrounding the WIPP AIS (Dale and Hurtado, 1996), and around seals (Knowles et al., 1996). A summary paper (Hansen et al., 1996) describing the design has been prepared.

The shaft sealing system is composed of seals within the Salado Formation, the Rustler Formation, and the Dewey Lake Redbeds and overlying units. All components of the sealing system are designed to meet Items 3, 4, and 6 of the Design Guidance (Table G2-7.); that is, all sealing system components are designed to be chemically and mechanically compatible with the seal environment, structurally adequate, and constructable using currently available technology and materials. The seals in the Salado Formation are also designed to meet Items 1 and 2 of the Design Guidance. These seals will limit fluid migration upward from the repository to the Rustler Formation and downward from the Rustler Formation to the repository. Migration of brine upward and downward is discussed in Sections 8.5 and 8.4 respectively. The seals in the Rustler Formation are designed to meet Item 2 in addition to Items 3, 4, and 6 of the Design Guidance. The seals in the Rustler Formation limit migration of Rustler brines into the shaft cross-section and also limit cross-flow between the Culebra and Magenta members. The principal function of the seals in the Dewey Lake Redbeds and overlying units is to meet Item 5 of the Design Guidance, that is, to limit subsidence of the ground surface in the vicinity of the shafts and to prevent accidental entry after repository closure. Entry of water (surface water and any groundwater that might be present in the Dewey Lake Redbeds and overlying units) into the sealing system is limited by restraining subsidence and by placing high density fill in the shafts.

4.2 Existing Shafts

The WIPP underground facilities are accessed by four shafts commonly referred to as the Waste, Air Intake, Exhaust, and Salt Handling Shafts. These shafts were constructed between 1981 and 1988. All four shafts are lined from the surface to just below the contact of the Rustler and Salado Formations. The lined portion of the shafts terminates in a substantial concrete structure called the "key," which is located in the uppermost portion of the Salado Formation.

Drawings showing the configuration of the existing shafts are included in Appendix G2-E and listed below in Table G2-8. Table G2-9 contains a summary of information describing the existing shafts.

The upper portions of the WIPP shafts are lined. The Waste, Air Intake, and Exhaust shafts have concrete linings; the Salt Handling Shaft has a steel lining with grout backing. In addition, during shaft construction, steel liner plates, wire mesh, and pressure grouting were used to stabilize portions of the shaft walls in the Rustler Formation and overlying units. Seepage of groundwater into the lined portions of the shafts has been observed. This seepage was expected; in fact, the shaft keys (massive concrete structures located at the base of each shaft liner) were designed to collect the seepage and transport it through a piping system to collection points at the repository horizon. In general, the seepage originates in the Magenta and Culebra members of the Rustler Formation and in the interface zone between the Rustler and Salado formations. It flows along the interface between the shaft liner and the shaft wall and through the DRZ immediately adjacent to the shaft wall. In those cases where seepage through the liner occurred, it happened where the liner offered lower resistance to flow than the interface and DRZ, for example, at construction joints. Maintenance grouting, in selected areas of the WIPP shafts, has been utilized to reduce seepage.

**Table G2-8
 Drawings Showing Configuration of Existing WIPP Shafts (Drawings are in Appendix G2-E)**

Shaft	Drawing Title	Sheet Number of Drawing SNL-007
Waste	Near-Surface/Rustler Formation Waste Shaft Stratigraphy & As-Built Elements	2 of 28
Waste	Salado Formation Waste Shaft Stratigraphy & As-Built Elements	3 of 28
AIS	Near-Surface/Rustler Formation Air Intake Shaft Stratigraphy & As-Built Elements	7 of 28
AIS	Salado Formation Air Intake Shaft Stratigraphy & As-Built Elements	8 of 28
Exhaust	Near-Surface/Rustler Formation Exhaust Shaft Stratigraphy & As-Built Elements	12 of 28
Exhaust	Salado Formation Exhaust Shaft Stratigraphy & As-Built Elements	13 of 28
Salt Handling	Near-Surface/Rustler Formation Salt Handling Shaft Stratigraphy & As-Built Elements	17 of 28
Salt Handling	Salado Formation Salt Handling Shaft Stratigraphy & As-Built Elements	18 of 28

1
 2

**Table G2-9
 Summary of Information Describing Existing WIPP Shafts**

	Shafts			
	Salt Handling	Waste	Air Intake	Exhaust
A. Construction Method				
i. Sinking method	Blind bored	Initial 6' pilot hole slashed by drill & blast (smooth wall blasting)	Raise bored	Initial 6' pilot hole slashed by drill & blast (smooth wall blasting)
ii. Dates of shaft sinking	7/81-10/81	Drilled 12/81-2/82 Slashed 10/83-6/84	12/87-8/88	9/83-11/84
iii. Ground treatment in water-bearing zone	Grout behind steel liner during construction	Grouted 1984 & 1988	Grouted 1993	Grouted 1985, 1986, & 1987
iv. Sump construction	Drill & blast	Drill & blast	No sump	No sump
B. Upper Portion of Shaft *				
i. Type of liner	Steel	Concrete	Concrete	Concrete
ii. Lining diameter (ID)	10'-0"	19'-0"	18'-0"/16'-7"	14'-0"
iii. Excavated diameter	11'-10"	20'-8" to 22'-4"	20'-3"	15'-8" to 16'-8"
iv. Installed depth of liner	838.5'	812'	816'	846'
C. Key Portion of Shaft *				
i. Construction material	Reinf. conc. w/chem. seals	Reinf. concrete w/chem. seals	Reinf. concrete w/chem. seals	Reinf. concrete w/chem. seals
ii. Liner diameter (ID)	10'-0"	19'-0"	16'-7"	14'-0"
iii. Excavated diameter	15'-0" to 18'-0"	27'-6" to 31'-0"	29'-3" to 35'-3"	21'-0" to 26'-0"
iv. Depth-top of Key	844'	836'	834'	846'
v. Depth-bottom of Key	883'	900'	897'	910'
vi. Dow Seal #1 depth	846' to 848'	846' to 849'	839' to 842'	853' to 856'
vii. Dow Seal #2 depth	853' to 856'	856' to 859'	854' to 857'	867' to 870'
viii. Dow Seal #3 depth	868 to 891'	NA	NA	NA
ix. Top of salt (Rustler/Salado contact)	851'	843'	841'	853'

	Shafts			
	Salt Handling	Waste	Air Intake	Exhaust
D. <u>Lower Shaft (Unlined) *</u>				
i. Type of support	Unlined	Chain link mesh	Unlined	Chain link mesh
ii. Excavated diameter	11'-10"	20'-0"	20'-3"	15'-0"
iii. Depth-top of "unlined"	882'	900'	904'	913'
iv. Depth-bottom of "unlined"	2144'	2142'	2128'	2148'
E. <u>Station *</u>				
i. Type of support	Wire mesh		Wire mesh	Wire mesh
ii. Principal dimensions	21H x 31W	12H x 30W	25H x 36W	12H x 23W
iii. Depth-top of station	2144'	2142'	2128'	2148'
iv. Depth-floor of station	2162'	2160'	2150'	2160'
F. <u>Sump *</u>				
Depth-top of sump	2162'	2160'	No sump	No sump
Depth-bottom of sump	2272'	2286'		
G. <u>Shaft Duty</u>	Construction hoisting of excavated salt; personnel hoisting; for intake (fresh) air; in some cases, unfiltered exhaust shaft to ventilate areas of the underground that do not need filtration	Hoisting shaft for lowering waste containers; personnel hoisting until waste receipt	Ventilation shaft for intake (fresh) air; personnel hoisting	Exhaust air ventilation shaft

*This information is from the MOC drawings identified on Sheets 2, 3, 7, 8, 12, 13, 17, and 18 of Drawing SNL-007 (see Appendix G2-E).

4.3 Sealing System Design Description

This section describes the shaft sealing system design, components, and functions. The shaft sealing system consists of three essentially independent parts:

1. The seals in the Salado Formation provide the primary regulatory barrier. They will limit fluid flow into and out of the repository throughout the 10,000-year regulatory period.
2. The seals in the Rustler Formation will limit flow from the water-bearing members of the Rustler Formation and limit commingling of Magenta and Culebra groundwaters.
3. The seals in the Dewey Lake Redbeds and the near-surface units will limit infiltration of surface water and preclude accidental entry through the shaft openings.

The same sealing system is used in all four shafts. Therefore an understanding of the sealing system for one shaft is sufficient to understand the sealing system in all shafts. Only minor differences exist in the lengths of the components, and the component diameters differ to accommodate the existing shaft diameters.

The shaft liner will be removed in four locations in each shaft. All of these locations are within the Rustler Formation. Additionally, the upper portion of each shaft key will be eliminated. The portion of the shaft key that will be eliminated spans the Rustler/Salado interface and extends into the Salado Formation. The shaft liner removal locations are

1. from 10 ft above the Magenta Member to the base of the Magenta (removal distances vary from 34–39 ft because of different member thickness at shaft locations),
2. for a distance of 10 ft in the anhydrite of the Tamarisk Member,
3. through the full height of the Culebra (17–24 ft), and
4. from the top anhydrite unit in the unnamed lower member to the top of the key (67–85 ft).

Additionally, the concrete will be removed from the top of the key to the bottom of the key's lower chemical seal ring (23 to 29 ft). Drawing SNL-007, Sheets 4, 9, 14, and 19 in Appendix G2-E show shaft liner removal plans, and Sheet 23 shows key removal plans.

The decision to abandon portions of the shaft lining and key in place is based on two factors. First, no improvements in the performance of the sealing system associated with removal of these isolated sections of concrete have been identified. Second, because the keys are thick and heavily reinforced, their removal would be costly and time consuming. No technical problems are associated with the removal of this concrete; thus, if necessary, its removal can be incorporated in any future design.

The DRZ will be pressure grouted throughout the liner and key removal areas and for a distance of 10 ft above and below all liner removal areas. The pressure grouting will stabilize the DRZ during liner removal and shaft sealing operations. The grouting will also control groundwater seepage during and after liner removal. The pressure grouting of the DRZ has not been

assigned a sealing function beyond the construction period. It is likely that this grout will seal the DRZ for an extended period of time. However, past experience with grout in the mining and tunneling industries demonstrates that groundwater eventually opens alternative pathways through the media and reestablishes seepage patterns (maintenance grouting is common in both mines and tunnels). Therefore, post-closure sealing of the DRZ in the Rustler Formation has not been assumed in the design.

The compacted clay sealing material (bentonite) will seal the shaft cross-section in the Rustler Formation. In those areas where the shaft liner has been removed, the compacted clay will confine the vertical movement of groundwater in the Rustler to the DRZ. Sealing the shaft DRZ is accomplished in the Salado Formation. It is achieved initially through the interruption of the halite DRZ by concrete-asphalt waterstops and on a long-term basis through the natural process of healing the halite DRZ. The properties of the compacted clay are discussed in Section 5.3.2. The concrete-asphalt waterstops and DRZ healing in the Salado are discussed in Sections 7.6.1 and 7.5.2 respectively.

Reduction of the uncertainty associated with long-term performance is addressed by replacing the upper and lower Salado Formation salt columns used in some of the earlier designs with compacted clay columns and by adding asphalt sealing components in the Salado Formation. Use of disparate materials for sealing components reduces the uncertainty associated with a common-mode failure.

The compacted salt column provides a seal with an initial permeability several orders of magnitude higher than the clay or asphalt columns; however, its long-term properties will approach those of the host rock. The permeability of the compacted salt, after consolidation, will be several orders of magnitude lower than that of the clay and comparable to that of the asphalt. The clay provides seals of known low permeability at emplacement, and asphalt provides an independent low permeability seal of the shaft cross-section and the shaft wall interface at the time of installation. Sealing of the DRZ in the Rustler Formation during the construction period is accomplished by grouting, and initial sealing of the DRZ in the Salado Formation is accomplished by three concrete-asphalt waterstops.

In the following sections, each component of each of the three shaft segments is identified by name and component number (see Figure G2-5 for nomenclature). Associated drawings in Appendix G2-E are also identified. Drawings showing the overall system configurations for each shaft are listed in Table G2-10.

4.3.1 Salado Seals

The seals placed in the Salado Formation are composed of (1) consolidated salt, clay, and asphalt components that will function for very long periods, exceeding the 10,000-year regulatory period; and (2) salt saturated concrete components that will function for extended periods. The specific components that comprise the Salado seals are described below.

4.3.1.1 Compacted Salt Column

The compacted salt column (Component 10 in Figure G2-5, and shown in Drawing SNL-007, Sheet 25) will be constructed of crushed salt taken from the Salado Formation. The length of the salt column varies from 170 to 172 m (556 to 564 ft) in the four shafts. The compacted salt column is sized to allow the column and concrete-asphalt waterstops at either end to be placed

between the Vaca Triste Unit and Marker Bed 136. The salt will be placed and compacted to a density approaching 90% of the average density of intact Salado salt. The effects of creep closure will cause this density to increase with time, further reducing permeability.

The salt column will offer limited resistance to fluid migration immediately after emplacement, but it will become less permeable as creep closure further compacts the salt. Salt creep increases rapidly with depth; therefore, at any time, creep closure of the shaft will be greater at greater depth. The location and initial compaction density of the compacted salt column were chosen to assure consolidation of the compacted salt column in the 100 years following repository closure. The state of salt consolidation, results of analyses predicting the creep closure of the shaft, consolidation and healing of the compacted salt, and healing of the DRZ surrounding the compacted salt column are presented in Sections 7.5 and 8.4 of this document. These results indicate that the salt column will become an effective long-term barrier within 100 years.

Table G2-10
Drawings Showing the Sealing System for Each Shaft (Drawings are in Appendix G2-E)

Shaft	Drawing Title	Sheet Number of Drawing SNL 007
Waste	Near-Surface/Rustler Formation Waste Shaft Stratigraphy & Sealing Subsystem Profile	4 of 28
Waste	Salado Formation Waste Shaft Stratigraphy & Sealing Subsystem Profile	5 of 28
AIS	Near-Surface/Rustler Formation Air Intake Shaft Stratigraphy & Sealing Subsystem Profile	9 of 28
AIS	Salado Formation Air Intake Shaft Stratigraphy & Sealing Subsystem Profile	10 of 28
Exhaust	Near-Surface/Rustler Formation Exhaust Shaft Stratigraphy & Sealing Subsystem Profile	14 of 28
Exhaust	Salado Formation Exhaust Shaft Stratigraphy & Sealing Subsystem Profile	15 of 28
Salt Handling	Near-Surface/Rustler Formation Salt Handling Shaft Stratigraphy & Sealing Subsystem Profile	19 of 28
Salt Handling	Salado Formation Salt Handling Shaft Stratigraphy & Sealing Subsystem Profile	20 of 28

4.3.1.2 Upper and Lower Salado Compacted Clay Columns

The upper and lower Salado compacted clay columns (Components 8 and 12 respectively in Figure G2-5) are shown in detail on Drawing SNL-007, Sheet 24. A commercial well-sealing grade sodium bentonite will be used to construct the upper and lower Salado clay columns. These clay columns will effectively limit fluid movement from the time they are placed and will provide an effective barrier to fluid migration throughout the 10,000-year regulatory period and thereafter. The upper clay column ranges in length from 102 to 107 m (335 to 351 ft), and the lower clay column ranges in length from 29 to 33 m (94 to 107 ft) in the four shafts. The locations for the upper and lower clay columns were selected based on the need to limit fluid migration into the compacting salt column. The lower clay column stiffness is sufficient to

promote early healing of the DRZ, thus removing the DRZ as a potential pathway for fluids (Appendix D in the Compliance Submittal Design Report (Sandia, 1996), Section 5.2.1).

4.3.1.3 Upper, Middle, and Lower Concrete-Asphalt Waterstops

The upper, middle, and lower concrete-asphalt waterstops (Components 7, 9, and 11 respectively in Figure G2-5) are identical and are composed of three elements: an upper concrete plug, a central asphalt waterstop, and a lower concrete plug. These components are also shown on Drawing SNL-007, Sheet 22. The concrete specified is a specially developed salt-saturated concrete called Salado Mass Concrete (**SMC**). In all cases the component's overall design length is 15 m (50 ft).

The upper and lower concrete plugs of the concrete-asphalt waterstop are identical. They fill the shaft cross-section and have a design length of 7 m (23 ft). The plugs are keyed into the shaft wall to provide positive support for the plug and overlying sealing materials. The interface between the concrete plugs and the surrounding formation will be pressure grouted. The upper plug in each component will support dynamic compaction of the overlying sealing material if compaction is specified. Dynamic compaction of the salt column is discussed in Section 6.

The asphalt waterstop is located between the upper and lower concrete plugs. In all cases a kerf extending one shaft radius beyond the shaft wall is cut in the surrounding salt to contain the waterstop. The kerf is 0.3 m (1 ft) high at its edge and 0.6 m (2 ft) high at the shaft wall. The kerf, which cuts through the existing shaft DRZ, will result in the formation of a new DRZ along its perimeter. This new DRZ will heal shortly after construction of the waterstop, and thereafter the waterstop will provide a very low permeability barrier to fluid migration through the DRZ. The formation and healing of the DRZ around the waterstop are addressed in Section 7.6.1. The asphalt fill for the waterstop extends two feet above the top of the kerf to assure complete filling of the kerf. The construction procedure used assures that shrinkage of the asphalt from cooling will not result in the creation of voids within the kerf and will minimize the size of any void below the upper plug.

Concrete-asphalt waterstops are placed at the top of the upper clay column, the top of the compacted salt column, and the top of the lower clay column. The concrete-asphalt waterstops provide independent seals of the shaft cross-section and the DRZ. The SMC plugs (and grout) will fill irregularities in the shaft wall, bond to the shaft wall, and seal the interface. Salt creep against the rigid concrete components will place a compressive load on the salt and promote early healing of the salt DRZ surrounding the SMC plugs. The asphalt waterstop will seal the shaft cross-section and the DRZ.

The position of the concrete components was first determined by the location of the salt and clay columns. The components were then moved upward or downward from their initial design location to assure the components were located in regions where halite was predominant. This positioning, coupled with variations in stratigraphy, is responsible for the variations in the lengths of the salt and clay columns.

4.3.1.4 Asphalt Column

An asphalt-aggregate mixture is specified for the asphalt column (Component 6 in Figure G2-5). This column is 42 to 44 m (138 to 143 ft) in length in the four shafts, as shown in Drawing SNL-007, Sheet 23. The asphalt column is located above the upper concrete-asphalt waterstop; it

extends approximately 5 m (16 ft) above the Rustler/Salado interface. A 6-m (20-ft) long concrete plug (part of the Rustler seals) is located just above the asphalt column.

The existing shaft linings will be removed from a point well above the top of the asphalt column to the top of the shaft keys. The concrete shaft keys will be removed to a point just below the lowest chemical seal ring in each key. The asphalt column is located at the top of the Salado Formation and provides an essentially impermeable seal for the shaft cross section and along the shaft wall interface. The length of the asphalt column will decrease slightly as the column cools. The procedure for placing the flowable asphalt-aggregate mixture is described in Section 6.

4.3.1.5 Shaft Station Monolith

A shaft station monolith (Component 13) is located at the base of the each shaft. Because the configurations of each shaft differ, drawings of the shaft station monoliths for each shaft were prepared. These drawings are identified in Table G2-11. The shaft station monoliths will be constructed with SMC. The monoliths function to support the shaft wall and adjacent drift roof, thus preventing damage to the seal system as the access drift closes from natural processes.

Table G2-11
Drawings Showing the Shaft Station Monoliths (Drawings are in Appendix G2-E)

Shaft	Drawing Title	Sheet Number of Drawing SNL-007
Waste	Waste Shaft Shaft Station Monolith	6 of 28
ALS	Air Intake Shaft Shaft Station Monolith	11 of 28
Exhaust	Exhaust Shaft Shaft Station Monolith	16 of 28
Salt Handling	Salt Handling Shaft Shaft Station Monolith	21 of 28

4.3.2 Rustler Seals

The seals in the Rustler Formation are composed of the Rustler compacted clay column and a concrete plug. The concrete plug rests on top of the asphalt column of the Salado seals. The clay column extends from the concrete plug through most of the Rustler Formation and terminates above the Rustler's highest water-bearing zone in the Forty-niner Member.

4.3.2.1 Rustler Compacted Clay Column

The Rustler compacted clay column (Component 4 in Figure G2-5) is shown on Drawing SNL-007, Sheet 27 for each of the four shafts. A commercial well-sealing-grade sodium bentonite will be used to construct the Rustler clay column, which will effectively limit fluid movement from the time of placement and provide an effective barrier to fluid migration throughout the 10,000-year regulatory period and thereafter. Design length of the Rustler clay column is about 71 m (234 to 235 ft) in the four shafts.

The location for the Rustler clay columns was selected to limit fluid migration into the shaft cross-section and along the shaft wall interface and to limit mixing of Culebra and Magenta waters. The clay column extends from above the Magenta Member to below the Culebra

Member of the Rustler Formation. The Magenta and Culebra are the water-bearing units of the Rustler. The members above the Magenta (the Forty-niner), between the Magenta and Culebra (the Tamarisk), and below the Culebra (the unnamed lower member) are aquitards in the vicinity of the WIPP shafts.

4.3.2.2 Rustler Concrete Plug

The Rustler concrete plug (Component 5 in Figure G2-5) is constructed of SMC. The plugs for the four shafts are shown on Drawing SNL-007, Sheet 26. The plug is 6 m (20 ft) long and will fill the shaft cross-section. The plug is placed directly on top of the asphalt column of the Salado seals. The plug will be keyed into the surrounding rock and grouted. The plug permits work to begin on the overlying clay column before the asphalt has completely cooled. The option of constructing the overlying clay columns using dynamic compaction (present planning calls for construction using compressed clay blocks) is also maintained by keying the plug into the surrounding rock.

4.3.3 Near-Surface Seals

The near-surface region is composed of dune sand, the Mescalero caliche, the Gatuña Formation, the Santa Rosa Formation, and the Dewey Lake Redbeds. This region extends from the ground surface to the top of the Rustler Formation—a distance of about 160 m (525 ft). All but about 15 m (50 ft) of this distance is composed of the Dewey Lake Redbeds Formation. The near-surface seals are composed of two earthen fill columns and a concrete plug. The upper earthen fill column (Component 1) extends from the shaft collar through the surficial deposits downward to the top of the Dewey Lake Redbeds. The concrete plug (Component 2) is placed in the top portion of the Dewey Lake Redbeds, and the lower earthen fill column (Component 3) extends from the concrete plug into the Rustler Formation. These components are shown on Drawing SNL-007, Sheet 28.

This seal will limit the amount of surface water entering the shafts and will limit the potential for any future groundwater migration into the shafts. The near surface seals will also completely close the shafts and prevent accidental entry and excessive subsidence in the vicinity of the shafts. As discussed in Section 4.3.2, the existing shaft linings will be abandoned in place throughout the near-surface region.

4.3.3.1 Near-Surface Upper Compacted Earthen Fill

This component (Component 1 in Figure G2-5) will be constructed using locally available fill. The fill will be compacted to a density near that of the surrounding material to inhibit the migration of surface waters into the shaft cross-section. The length of this column varies from 17 to 28 m (56 to 92 ft) in the four shafts. In all cases, this portion of the WIPP sealing system may be modified as required to facilitate decommissioning of the WIPP surface facilities.

4.3.3.2 Near-Surface Concrete Plug

Current plans call for an SMC plug (Component 2 in Figure G2-5). However, freshwater concrete may be used if found to be desirable at a future time, and if approved by NMED through the Permit modification process specified in 20.4.1.900 NMAC (incorporating 40 CFR §270.42). The plug extends 12 m (40 ft) downward from the top of the Dewey Lake Redbeds. It is placed inside the existing shaft lining, and the interface is grouted.

4.3.3.3 Near-Surface Lower Compacted Earthen Fill

This component (Component 3 in Figure G2-5) will be constructed using locally available fill, which will be placed using dynamic compaction (the same method used to construct the salt column). The fill will be compacted to a density equal to or greater than the surrounding materials to inhibit the migration of surface waters into the shaft cross-section. The length of this column varies from 136 to 148 m (447 to 486 ft) in the four shafts.

5. Material Specification

Appendix G2-A provides a body of technical information for each of the WIPP shaft seal materials. The materials specification characterizes each seal material, establishes the adequacy of its function, states briefly the method of component placement, and quantifies expected characteristics (particularly permeability) pertinent to a WIPP-specific shaft seal design. The goal of the materials specifications is to substantiate why materials used in this seal system design will limit fluid flow within the shafts and thereby limit releases of hazardous constituents from the WIPP site at the regulatory boundary.

This section summarizes materials characteristics for shaft seal system components designed for the WIPP. The shaft seal system will not be constructed for decades; however, if it were to be constructed in the near term, materials specified could be placed in the shaft and meet performance specifications using current materials and construction techniques. Construction methods are described in Appendix G2-B. Materials specifications and construction specifications are not to be construed as the only materials or methods that would suffice to seal the shafts effectively. Undoubtedly, the design will be modified, perhaps simplified, and construction alternatives may prove to be advantageous during the years before seal construction proceeds. Nonetheless, a materials specification is necessary to establish a frame of reference for shaft seal design and analysis, to guide construction specifications, and to provide a basis for seal material parameters.

Design detail and other characteristics of the geologic, hydrologic, and chemical setting are provided in the text, appendices, and references. The four shafts will be entirely filled with dense materials possessing low permeability and other desirable engineering and economic attributes. Seal materials include concrete, clay, asphalt, and compacted salt. Other construction and fill materials include cementitious grout and earthen fill. Concrete, clay, and asphalt are common construction materials used extensively in sealing applications. Their descriptions, drawn from literature and site-specific references, are given in Appendix G2-A. Compaction and natural reconsolidation of crushed salt are uniquely applied here. Therefore, crushed salt specification includes discussion of constitutive behavior and sealing performance, specific to WIPP applications. Cementitious grout is also specified in some detail. Only rudimentary discussion of earthen fill is given here and in Appendices A and B. Specifications for each material are discussed in the following order:

- functions,
- material characteristics,
- construction,
- performance requirements,
- verification methods.

Seal system components are materials possessing high durability and compatibility with the host rock. The system contains functional redundancy and uses differing materials to reduce uncertainty in performance. All materials used in the shaft seal system are expected to maintain their integrity for very long periods. Some sealing components reduce fluid flow soon after placement while other components are designed to function well beyond the regulatory period.

5.1 Longevity

A major environmental advantage of the WIPP locale is an overall lack of groundwater to seal against. Even though very little regional water is present in the geologic setting, the seal system reflects great concern for groundwater's potential influence on the shaft seal system. If the hydrologic system sustained considerable fluid flow, brine geochemistry could impact engineered materials. Brine would not chemically change the compacted salt column, but mechanical effects of pore pressure are of concern to reconsolidation. The geochemical setting, as further discussed in Section 2.4, will have little influence on concrete, asphalt, and clay shaft seal materials. Each material is durable because the potential for degradation or alteration is very low.

Materials used to form the shaft seals are the same as those identified in the scientific and engineering literature as appropriate for sealing deep geologic repositories for radioactive wastes. Durability or longevity of seal components is a primary concern for any long-term isolation system. Issues of possible degradation have been studied throughout the international community and within waste isolation programs in the USA. Specific degradation studies are not detailed in this document because longevity is one of the over-riding attributes of the materials selected and degradation is not perceived to be likely. However, it is acknowledged here that microbial degradation, seal material interaction, mineral transformation, such as silicification of bentonite, and effects of a thermal pulse from asphalt or hydrating concrete are areas of continuing investigations.

Among longevity concerns, degradation of concrete is the most recognized. At this stage of the design, it is established that only small volumes of brine ever reach the concrete elements (see Section C4 of the Compliance Submittal Design Report (Sandia, 1996)). Further analysis concerned with borehole plugging using cementitious materials shows that at least 100 pore volumes of brine in an open system would be needed to begin degradation processes. In a closed system, such as the hydrologic setting in the WIPP shafts, phase transformations create a degradation product of increased volume. Net volume increase owing to phase transformation in the absence of mass transport would decrease rather than increase permeability of concrete seal elements.

Asphalt has existed for thousands of years as natural seeps. Longevity studies specific to DOE's Hanford site have utilized asphalt artifacts buried in ancient ceremonies to assess long-term stability (Wing and Gee, 1994). Asphalt used as a seal component deep in the shaft will inhabit a benign environment, devoid of ultraviolet light or an oxidizing atmosphere. Additional assurance against possible microbial degradation in asphalt elements is provided with addition of lime. For these reasons, it is believed that asphalt components will possess their design characteristics well beyond the regulatory period.

Natural bentonite is a stable material that generally will not change significantly over a period of ten thousand years. Bentonitic clays have been widely used in field and laboratory experiments concerned with radioactive waste disposal. As noted by Gray (1993), three internal mechanisms, illitization, silicification and charge change, could affect sealing properties of bentonite. Illitization and silicification are thermally driven processes and, following discussion by Gray (1993), are not possible in the environment or time-frame of concern at the WIPP. The naturally occurring Wyoming bentonite which is the specified material for the WIPP shaft seal is well over a million years old. It is, therefore, highly unlikely that the metamorphism of bentonite enters as a design concern.

5.2 Materials

5.2.1 Mass Concrete

Concrete has low permeability and is widely used for hydraulic applications. The specification for mass concrete presents a special design mixture of a salt-saturated concrete called Salado Mass Concrete (**SMC**). Performance of SMC and similar salt-saturated mixtures has been established through analogous industrial applications and in laboratory and field testing. The documentation substantiates adequacy of SMC for concrete applications within the WIPP shafts.

The function of the concrete is to provide durable components with small void volume, adequate structural compressive strength, and low permeability. SMC is used as massive plugs, a monolith at the base of each shaft, and in tandem with asphalt waterstops. Concrete is a rigid material that will support overlying seal components while promoting natural healing processes within the salt DRZ. Concrete is one of the redundant components that protects the reconsolidating salt column. The salt column will achieve low permeabilities in fewer than 100 years, and concrete will no longer be needed at that time. However, concrete will continue to provide good sealing characteristics for a very long time.

Salt-saturated concrete contains sufficient salt as an aggregate to saturate hydration water with respect to NaCl. Salt-saturated concrete is required for all uses within the Salado Formation because fresh water concrete would dissolve part of the host rock. The concrete specified for the shaft seal system has been tailored for the service environment and includes all the engineering properties of high quality concrete, as described in Appendix G2-A. Among these are low heat of hydration, high compressive strength, and low permeability. Because SMC provides material characteristics of high-performance concrete, it will likely be the concrete of choice for all seal applications at the WIPP.

Construction involves surface preparation and slickline placement. A batching and mixing operation on the surface will produce a wet mixture having low initial temperatures. Placement uses a tremie line, where the fresh concrete exits the slickline below the surface level of the concrete being placed. Placed in this manner, the SMC will have low porosity (about 5%) with or without vibration. Tremie line placement is a standard construction method in mining operations.

Specifications of concrete properties include mixture proportions and characteristics before and after hydration. SMC strength is much greater than required for shaft seal elements, and the state of stress within the shafts is compressional with little shear stress developing. Volume stability of the SMC is also excellent; this, combined with salt-saturation, assures a good bond with the salt. Permeability of SMC is very low, consistent with most concrete (Pfeifle et al., 1996). Because of a favorable state of stress and isothermal conditions, the SMC will remain intact. Because little brine is available to alter concrete elements, minimal degradation is possible. These favorable attributes combine to assure concrete elements within the Salado will remain structurally sound and possess very low permeability (between 2×10^{-21} and 1×10^{-17} m²) for exceedingly long periods. A permeability distribution function and associated discussion are given in Appendix G2-A.

Standard ASTM specifications are made for the green and hydrated concrete properties. Quality control and a history of successful use in both civil construction and mining applications assure proper placement and performance.

5.2.2 Compacted Clay

Compacted clays are commonly proposed as primary sealing materials for nuclear waste repositories and have been extensively investigated against rigorous performance requirements. Advantages of clays for sealing purposes include low permeability, demonstrated longevity in many types of natural environments, deformability, sorptive capacity, and demonstrated successful utilization in practice for a variety of sealing purposes.

Compacted clay as a shaft sealing component functions as a barrier to brine flow and possibly to gas flow (see alternative construction methods in Appendix G2-B). Compacted bentonitic clay can generate swelling pressure and clays have sufficient rigidity to promote healing of any DRZ in the salt. Wetted swelling clay will seal fractures as it expands into available space and will ensure tightness between the clay seal component and the shaft walls.

The Rustler and Salado compacted clay columns are specified to be constructed of dense sodium bentonite blocks. An extensive experimental data base exists for the permeability of sodium bentonites under a variety of conditions. Many other properties of sodium bentonite, such as strength, stiffness, and chemical stability, are established. Bentonitic clays heal when fractured and can penetrate small fractures or irregularities in the host rock. Further, bentonite is stable in the seal environment. These properties, noted by international waste isolation programs, make bentonite a widely accepted seal material.

From the bottom clay component to the top earthen fill, different methods will be used to place clay materials in the shaft. Seal performance within the Salado Formation is far more important to regulatory compliance of the seal system than is performance of clay and earthen fill in the overlying formations. Therefore, more time and effort will be expended on placement of Salado clay components. Three potential construction methods could be used to place clay in the shaft, as discussed in Appendix G2-B: compacted blocks, vibratory roller, and dynamic compaction. Construction of Salado clay components specifies block assembly.

Required sealing performance of compacted clay elements varies with location. For example, Component 4 provides separation of water-bearing zones, while the lowest clay column (Component 12) limits fluid flow to the reconsolidating salt column. If liquid saturation in the clay column of 85% can be achieved, it would serve as a gas barrier. In addition, compacted clay seal components promote healing of the salt DRZ. To achieve low permeabilities, the dry density of the emplaced bentonite should be about 1.8 g/cm³. A permeability distribution function for performance assessment and the logic for its selection are given in Appendix G2-A.

Verification of specified properties such as density, moisture content, permeability, or strength of compacted clay seals can be determined by direct measurement during construction. However, indirect methods are preferred because certain measurements, such as permeability, are likely to be time consuming and invasive. Methods used to verify the quality of emplaced seals will include quality of block production and field measurements of density.

5.2.3 Asphalt

Asphalt is used to prevent water migration down the shaft in two ways: as an asphalt column near the Rustler/Salado contact and as a "waterstop" sandwiched between concrete plugs at three locations within the Salado Formation. Asphalt components of the WIPP seal design add assurance that minimal transport of brine down the sealed shaft will occur.

Asphalt is a widely used construction material because of its many desirable engineering properties. Asphalt is a strong cement, readily adhesive, highly waterproof, and durable. Furthermore, it is a plastic substance that is readily mixed with mineral aggregates. A range of viscosity is achievable for asphalt mixtures. It is highly resistant to most acids, salts, and alkalis. These properties are well suited to the requirements of the WIPP shaft seal system.

Construction of the seal components containing asphalt can be accomplished using a slickline process where low-viscosity heated material is effectively pumped into the shaft. The technology to apply the asphalt in this manner is available as described in the construction procedures in Appendix G2-B.

The asphalt components are required to endure for about 100 years and limit brine flow down the shaft to the compacted salt component. Since asphalt will not be subjected to ultraviolet light or an oxidizing environment, it is expected to provide an effective seal for centuries. Air voids less than 2% ensure low permeability. The permeability of the massive asphalt column is expected to have an upper limit $1 \times 10^{-18} \text{ m}^2$.

Sufficient construction practice and laboratory testing information is available to assure performance of the asphalt component. Laboratory validation tests to optimize viscosity may be desirable before final installation specifications are prepared. In general, verification tests would add quantitative documentation to expected performance values and have direct application to WIPP.

5.2.4 Compacted Salt Column

A reconsolidated column of natural WIPP salt will seal the shafts permanently. If salt reconsolidation is unimpeded by fluid pore pressures, the material will eventually achieve extremely low permeabilities approaching those of the native Salado Formation. Recent developments in support of the WIPP shaft seal system have produced confirming experimental results, constitutive material models, and construction methods that substantiate use of a salt column to create a low permeability seal component. Reuse of salt excavated in the process of creating the underground openings has been advocated since its initial proposal in the 1950s. Replacing the natural material in its original setting ensures physical, chemical, and mechanical compatibility with the host formation.

The function of the compacted and reconsolidated salt column is to limit transmission of fluids into or out of the repository for the statutory period of 10,000 years. The functional period starts within a hundred years and lasts essentially forever. After a period of consolidation, the salt column will almost completely retard gas or brine migration within the former shaft opening. A completely consolidated salt column will achieve flow properties indistinguishable from natural Salado salt.

The salt component is composed of crushed Salado salt with additional small amounts of water. The total water content of the crushed salt will be adjusted to 1.5 wt% before it is tamped into place. Field and laboratory tests have verified that natural salt can be compacted to significant fractional density ($\rho \geq 0.9$) with addition of these moderate amounts of water.

Dynamic compaction is the specified construction procedure to tamp crushed salt in the shaft. Deep dynamic compaction provides great energy to the crushed salt, is easy to apply, and has an effective depth of compactive influence greater than lift thickness. Dynamic compaction is

relatively straightforward and requires a minimal work force in the shaft. Compaction itself will follow procedures developed in a large-scale compaction demonstration, as outlined in Appendix G2-B.

Numerical models of the shaft provide density of the compacted salt column as a function of depth and time. Many calculations comparing models for consolidation of crushed salt were performed to quantify performance of the salt column, as discussed in Appendix D of the Compliance Submittal Design Report (Sandia, 1996) and the references (Callahan et al., 1996; Brodsky et al., 1996). From the density-permeability relationship of reconsolidating crushed salt, permeability of the compacted salt seal component is calculated. In general, results show that the bottom of the salt column consolidates rapidly, achieving permeability of $1 \times 10^{-19} \text{ m}^2$ in about 50 years. By 100 years, the middle of the salt column reaches similar permeability.

Results of the large-scale dynamic compaction demonstration suggest that deep dynamic compaction will produce a sufficiently dense starting material. As with other seal components, testing of the material in situ will be difficult and probably not optimal to ensure quality of the seal element. This is particularly apparent for the compacted salt component because the compactive effort produces a finely powdered layer on the top of each lift. It was demonstrated (Hansen and Ahrens, 1996) that the fine powder is very densely compacted upon tamping the superincumbent lifts. The best means to ensure that the crushed salt element is placed properly is to establish performance through verification of quality assurance/quality control procedures. If crushed salt is placed with a reasonable uniformity of water and compacted with sufficient energy, long-term performance can be assured.

5.2.5 Cementitious Grout

Cementitious grouting is specified for all concrete members. Grouting is also used in advance of liner removal to stabilize the ground and to limit water inflow during shaft seal construction. Cementitious grout is specified because of its proven performance, nontoxicity, and previous use at the WIPP.

The function of grout is to stabilize the surrounding rock before existing concrete liners are removed. Grout will fill fractures within adjacent lithologies, thereby adding strength and reducing permeability and, hence, water inflow during shaft seal construction. Grout around concrete members of the concrete asphalt waterstop will be employed in an attempt to tighten the interface and fill microcracks in the DRZ. Efficacy of grouting will be determined during construction.

An ultrafine cementitious grout has been specifically developed for use at the WIPP (Ahrens and Onofrei, 1996). This grout consists of Type 5 portland cement, pumice as a pozzolanic material, and superplasticizer. The average particle size is approximately 2 microns. The ultrafine grout is mixed in a colloidal grout mixer, with a water to components ratio (W:C) of 0.6:1.

Drilling and grouting sequences provided in Appendix G2-B follow standard procedures. Grout will be mixed on the surface and transported by slickline to the middle deck on the multi-deck stage (galloway). Grout pressures are specified below lithostatic to prevent hydrofracturing.

Performance of grout is not a consideration for compliance issues. Grouting of concrete elements is an added assurance to tighten interfaces. Grouting is used to facilitate construction by stabilizing any loose rock behind the concrete liner.

No verification of the effectiveness of grouting is currently specified. If injection around concrete plugs is possible, an evaluation of quantities and significance of grouting will be made during construction. Procedural specifications will include measurements of fineness and determination of rheology in keeping with processes established during the WIPP demonstration grouting (Ahrens et al., 1996).

5.2.6 Earthen Fill

A brief description of the earthen fill is provided in Appendix G2-A, and construction is summarized in Appendix G2-B. Compacted fill can be obtained from local borrow pits, or material excavated during shaft construction can be returned to the shaft. There are minimal design requirements for earthen fill and none that are related to WIPP regulatory performance.

5.3 Concluding Remarks

Materials specifications in Appendix G2-A provide descriptions of seal materials along with reasoning on their expected reliability in the WIPP setting. The specification follows a framework that states the function of the seal component, a description of the material, and a summary of construction techniques. The performance requirements for each material are detailed. Materials chosen for use in the shaft seal system have several common desirable attributes: low permeability, high density, compatibility, longevity, low cost, constructability, availability, and supporting documentation.

6. Construction Techniques

Construction of the shaft sealing system is feasible. The described procedures utilize currently available technology, equipment, and materials to satisfy shaft sealing system design guidance. Although alternative methods are possible, those described satisfy the design guidance requirements listed in Table G2-7 and detailed in the appendices. Construction feasibility is established by reference to comparable equipment and activities in the mining, petroleum, and food industries and test results obtained at the WIPP. Equipment and procedures for emplacement of sealing materials are described below.

6.1 Multi-Deck Stage

A multi-deck stage (Figures G2-6 and G2-7) consisting of three vertically connected decks will be the conveyance utilized during the shaft sealing operation. Detailed sketches of the multi-deck stage appear in Appendix G2-E. The stage facilitates installation and removal of utilities and provides a working platform for the various sealing operations. A polar crane attached to the lower deck provides the mechanism required for dynamic compaction and excavation of the shaft walls. Additionally, the header at the bottom of the slickline is supported by a reinforced steel shelf, which is securely bolted to the shaft wall during emplacement of sealing materials. The multi-deck stage can be securely locked in place in the shaft whenever desired (e.g., during dynamic compaction, excavation of the salt walls of the shaft, grouting, liner removal, etc.). The multi-deck stage is equipped with floodlights, remotely aimed closed-circuit television, fold-out floor extensions, a jib crane, and range-finding devices. Similar stages are commonly employed in shaft sinking operations.

The polar crane can be configured for dynamic compaction (Figure G2-6) or for excavation of salt (Figure G2-7); a man cage or bucket can be lowered through the stage to the working surface below. Controlled manually or by computer, the crane and its trolley utilize a geared track drive. The crane can swiftly position the tamper (required for dynamic compaction) in the drop positions required (Figure G2-8) or accommodate the undercutter required for excavation of the shaft walls. The crane incorporates a hoist on the trolley and an electromagnet, enabling it to position, hoist, and drop the tamper. A production rate of one drop every two minutes during dynamic compaction is possible.

6.2 Salado Mass Concrete (Shaft Station Monolith and Shaft Plugs)

Salado Mass Concrete, described in Appendix G2-A, will be mixed on surface at 20°C and transferred to emplacement depth through a slickline (i.e., a steel pipe fastened to the shaft wall and used for the transfer of sealing materials from surface to the fill horizon) minimizing air entrainment and ensuring negligible segregation. Existing sumps will be filled to the elevation of the floor of the repository horizon, and emplacement of the shaft station monolith is designed to eliminate voids at the top (back) of the workings.

When excavating salt for waterstops or plugs in the Salado Formation, an undercutter attached to the trolley of the polar crane will be forced into the shaft wall by a combination of geared trolley and undercutter drives. Full circumferential cuts will be accomplished utilizing the torque developed by the geared polar crane drive.

The undercutter proposed is a modified version of those currently in use in salt and coal mines, where their performance is proven. Such modifications and applications have been judged feasible by the manufacturer.

The concrete-salt interface and DRZ around concrete plugs in the Salado Formation (and the one at the base of the Rustler Formation) will be grouted with ultrafine grout. Injection holes will be collared in the top of the plug and drilled downward at 45° below horizontal. The holes will be drilled in a “spin” pattern describing a downward opening cone designed to intercept both vertical and horizontal fractures (Figure G2-9). The holes will be stage grouted (i.e., primary holes will be drilled and grouted, one at a time). Secondary holes will then be drilled and grouted, one at a time, on either side of primaries that accepted grout.

6.3 Compacted Clay Columns (Salado and Rustler Formations)

Cubic blocks of sodium bentonite, 20.8 cm on the edge and weighing approximately 18 kg, will be precompacted on surface to a density between 1.8 and 2.0 gm/cm³ and emplaced manually. The blocks will be transferred from surface on the man cage. Block surfaces will be moistened with a fine spray of potable water, and the blocks will be manually placed so that all surfaces are in contact. Peripheral blocks will be trimmed to fit irregularities in the shaft wall, and remaining voids will be filled with a thick mortar of sodium bentonite and potable water. Such blocks have been produced at the WIPP and used in the construction of 0.9-m-diameter seals, where they performed effectively (Knowles and Howard, 1996). Alternatives, which may be considered in future design evaluations, are discussed in Appendix G2-B.

6.4 Asphalt Waterstops and Asphaltic Mix Columns

Neat asphalt is selected for the asphalt waterstops, and an asphaltic mastic mix (AMM) consisting of neat asphalt, fine silica sand, and hydrated lime will be the sealing material for the columns. Both will be fluid at emplacement temperature and remotely emplaced. Neat asphalt (or AMM, prepared in a pug mill near the shaft collar) will be heated to 180°C and transferred to emplacement depth via an impedance-heated, insulated tremie line (steel pipe) suspended from slips (pipe holding device) at the collar of the shaft.

This method of line heating is common practice in the mining and petroleum industries. This method lowers the viscosity of the asphalt so that it can be pumped easily. Remote emplacement by tremie line eliminates safety hazards associated with the high temperature and gas produced by the hot asphalt. Fluidity ensures that the material will flow readily and completely fill the excavations and shaft. Slight vertical shrinkage will result from cooling (calculations in Appendix D of the Compliance Submittal Design Report (Sandia, 1996)), but the material will maintain contact with the shaft walls and the excavation for the waterstop. Vertical shrinkage will be counteracted by the emplacement of additional material.

6.5 Compacted WIPP Salt

Dynamic compaction of mine-run WIPP salt has been demonstrated (Ahrens and Hansen, 1995). The surface demonstration produced salt compacted to 90% of in-place rock salt density, with a statistically averaged permeability of 1.65×10^{-15} m². Additional laboratory consolidation of this material at 5 MPa confining pressure (simulating creep closure of the salt) resulted in increased compaction and lower permeability (Brodsky, 1994). Dynamic compaction was

selected because it is simple, robust, proven, has excellent depth of compaction, and is applicable to the vertical WIPP shafts.

The compactive effect expanded laterally and downward in the demonstration, and observation during excavation of the compacted salt revealed that the lateral compactive effect will fill irregularities in the shaft walls. Additionally, the depth of compaction, which was greater than that of the three lifts of salt compacted, resulted in the bottom lift being additionally compacted during compaction of the two overlying lifts. This cumulative effect will occur in the shafts.

Construction of the salt column will proceed in the following manner:

- Crushed and screened salt will be transferred to the fill elevation via slickline. Use of slicklines is common in the mining industry, where they are used to transfer backfill materials or concrete to depths far greater than those required at the WIPP. Potable water will be added via a fine spray during emplacement at the fill surface to adjust the moisture content to 1.5 ± 0.3 wt%, accomplished by electronically coordinating the weight of the water with that of the salt exiting the hose.
- Dynamic compaction will then be used to compact the salt by dropping the tamper in specific, pre-selected positions such as those shown in Figure G2-8.

6.6 Grouting of Shaft Walls and Removal of Liners

The procedure listed below is a common mining practice which will be followed at each elevation where liner removal is specified. If a steel liner is present, it will be cut into manageable pieces and hoisted to the surface for disposal, prior to initiation of grouting.

Upward opening cones of diamond drill holes will be drilled into the shaft walls in a spin pattern (Figure G2-10) to a depth ensuring complete penetration of the Disturbed Rock Zone (DRZ) surrounding the shaft. For safety reasons, no major work will be done from the top deck; all sealing activities will be conducted from the bottom deck. The ends of the holes will be 3 m apart, and the fans will be 3 m apart vertically, covering the interval from 3 m below to 3 m above the interval of liner removal. Tests at the WIPP demonstrated that the ultrafine cementitious grout penetrated more than 2 m from the injection holes (Ahrens et al., 1996).

Injection holes will be drilled and grouted one at a time, as is the practice in stage grouting. Primary holes are grouted first, followed by the grouting of secondary holes on either side of primaries that accepted grout. Ultrafine grout will be injected below lithostatic pressure to avoid hydrofracturing the rock, proceeding from the bottom fan upward. Grout will be mixed on surface and transferred to depth via the slickline.

Radial, horizontal holes will then be drilled on a 0.3-m grid, covering the interval to be removed. These will be drilled to a depth sufficient to just penetrate the concrete liner. A chipping hammer will be used to break a hole through the liner at the bottom of the interval. This hole, approximately 0.3 m in diameter, will serve as "free face," to which the liner can be broken. Hydraulically-actuated steel wedges will then be used in the pre-drilled holes to break out the liner in manageable pieces, beginning adjacent to the hole and proceeding upward. Broken concrete will be allowed to fall to the fill surface, where it will be gathered and hoisted to the surface for disposal. Chemical seal rings will be removed as encountered.

6.7 Earthen Fill

Local soil, screened to produce a maximum particle dimension of approximately 15 mm, will be the seal material. This material will be transferred to the fill surface via the slickline and emplaced in the same manner as the salt. After adjusting the moisture content of the earthen fill below the concrete plug in the Dewey Lake Redbeds to achieve maximum compaction, the fill will be dynamically compacted, achieving a permeability as low as that of the enclosing formation.

The portion of the earthen fill above the plug will be compacted with a vibratory-impact sheepsfoot roller, a vibratory sheepsfoot roller, or a walk-behind vibratory plate compactor, because of insufficient height for dynamic compaction.

6.8 Schedule

For discussion purposes, it has been assumed that the shafts will be sealed two at a time. This results in the four shafts being sealed in approximately six and a half years. The schedules presented in Appendix G2-B are based on this logic. Sealing the shafts sequentially would require approximately eleven and a half years.

7. Structural Analyses of Shaft Seals

7.1 Introduction

The shaft seal system was designed in accordance with design guidance described in Section 3.2. To be successful, seal system components must exhibit desired structural behavior. The desired structural behavior can be as simple as providing sufficient strength to resist imposed loads. In other cases, structural behavior is critical to achieving desired hydrological properties. For example, permeability of compacted salt depends on the consolidation induced by shaft closure resulting from salt creep. In this example, results from structural analyses feed directly into fluid-flow calculations, which are described in Section 8, because structural behavior affects both time-dependent permeabilities of the compacted salt and pore pressures within the compacted salt. In other structural considerations, thermal effects are analyzed as they affect the constructability and schedule for the seal system. Thus a series of analyses, loosely termed structural analyses, were performed to accomplish three purposes:

1. to determine loads imposed on components and to assess both structural stability based on the strength of the component and mechanical interaction between components;
2. to estimate the influence of structural behavior of seal materials and surrounding rock on hydrological properties; and
3. to provide structural and thermal related information on construction issues.

For the most part, structural analyses rely on information and design details presented in the Design Description (Section 4), the Design Drawings (Appendix G2-E), and Material Specification (Section 5 and Appendix G2-A). Some analyses are generic, and calculation input and subsequent results are general in nature.

7.2 Analysis Methods

Finite-element modeling was the primary numerical modeling technique used to evaluate structural performance of the shaft seals and surrounding rock mass. Well documented finite-element computer programs, SPECTROM-32 and SPECTROM-41, were used in structural and thermal modeling, respectively. The computer program SALT_SUBSID was used in the subsidence modeling over the backfilled shaft-pillar area. Specific details of these computer programs as they relate to structural calculations are listed in Appendix D of the Compliance Submittal Design Report (Sandia, 1996), Section D2.

7.3 Models of Shaft Seals Features

Structural calculations require material models to characterize the behavior of (1) each seal material (concrete, crushed salt, compacted clay, and asphalt); (2) the intact rock lithologies in the near-surface, Rustler, and Salado formations; and (3) any DRZ within the surrounding rock. A general description of the material models used in characterizing each of these materials and features is given below. Details of the models and specific values of model parameters are given in Appendix D in the Compliance Submittal Design Report (Sandia, 1996), Section D3.

7.3.1 Seal Material Models

The SMC thermal properties required for the structural analyses (thermal conductivity, density, specific heat, and volumetric heat generation rate) were obtained from SMC test data. Concrete was assumed to behave as a viscoelastic material, based on experimental data, and the elastic modulus of SMC was modeled as age-dependent. Strength properties of SMC were specified in the design (see Appendix G2-A).

For crushed salt, the deformational model included a nonlinear elastic component and a creep consolidation component. The nonlinear elastic modulus was assumed to be density-dependent, based on laboratory test data performed on WIPP crushed salt. Creep consolidation behavior of crushed salt was based on three candidate models whose parameters were obtained from model fitting to hydrostatic and shear consolidation test data performed on WIPP crushed salt. Creep consolidation models include functional dependencies on density, mean stress, stress difference, temperature, grain size, and moisture content.

Compacted clay was assumed to behave according to a nonlinear elastic model in which shear stiffness is negligible, and asphalt was assumed to behave as a weak elastic material. Thermal properties of asphalt were taken from literature.

7.3.2 Intact Rock Lithologies

Salado salt was assumed to be argillaceous salt that is governed by the Multimechanism Deformation Coupled Fracture (MDCF) model, which is an extension of the Munson-Dawson (M-D) creep model. A temperature-dependent thermal conductivity was necessary.

Salado interbeds were assumed to behave elastically. Their material strength was assumed to be described by a Drucker-Prager yield function, consistent with values used in previous WIPP analyses.

Deformational behavior of the near-surface and Rustler Formation rock types was assumed to be time-invariant, and their strength was assumed to be described by a Coulomb criterion, consistent with literature values.

7.3.3 Disturbed Rock Zone Models

Two different models were used to evaluate the development and extent of the DRZ within intact salt. The first approach used ratios of time-dependent stress invariants to quantify the potential for damage or healing to occur. The second approach used the damage stress criterion according to the MDCF model for WIPP salt.

7.4 Structural Analyses of Shaft Seal Components

7.4.1 Salado Mass Concrete Seals

Five analyses related to structural performance of SMC seals were performed, including (1) a thermal analysis, (2) a structural analysis, (3) a thermal stress analysis, (4) a dynamic compaction analysis, and (5) an analysis of the effects of clay swelling pressure. This section presents these analyses and evaluates the results in terms of the performance of the SMC seal.

Details of these calculations are given in Appendix D in the Compliance Submittal Design Report (Sandia, 1996), Section D4.

7.4.1.1 Thermal Analysis of Concrete Seals

The objective of this calculation was to determine expected temperatures within (and surrounding) an SMC emplacement resulting from its heat of hydration. Results indicate that the concrete component temperature increases from ambient (27°C) to a maximum of 53°C at 0.02 year after emplacement. The maximum temperature in the surrounding salt is 38°C at approximately the same time. The thermal gradient within the concrete is approximately 1.5°C/m. Most of the higher temperatures are contained within the concrete. At a radial distance of 2 m into the surrounding salt, the temperature rise is less than 1°C. These conditions are favorable for proper performance of the SMC components. A 26°C temperature rise and a 1.5°C/m temperature gradient are not large enough to cause thermal cracking as the concrete cools (Andersen et al., 1992).

7.4.1.2 Structural Analysis of Concrete Seals

The objectives of this calculation were to determine (1) expected stresses within the concrete components caused by restrained creep of the surrounding salt and (2) expected stresses in the concrete component from weight of overlying seal material.

In the upper concrete-asphalt waterstop, radial stresses increase (compression is positive) from zero at time of emplacement ($t = 0$) to 2.5 MPa at $t = 50$ years. Similarly, radial stresses in the middle concrete component range from 3.5 to 4.5 MPa at 50 years after emplacement. In the lower concrete-asphalt waterstop, radial stresses range from 4.5 to 5.5 MPa at $t = 50$ years. All the calculated stresses are well below the unconfined compressive strength of the concrete (30 MPa).

The upper, middle, and lower concrete-asphalt waterstops are located at depths of 300, 420, and 610 m, respectively. When performing these calculations, it was assumed that each concrete component must support the weight of the overlying materials between it and the next concrete component above it. Using an average overburden density of 0.02 MPa/m, stresses induced by the overlying material are significantly less than the strength of the concrete. The structural integrity of concrete components will not be compromised by either induced radial stress or imposed vertical stress.

7.4.1.3 Thermal Stress Analysis of Concrete Seals

The objectives of this calculation were (1) to determine thermal stresses in concrete components from the heat of hydration and (2) to determine thermal impact on the creep of the surrounding salt.

Thermoelastic stresses in the concrete were calculated based on a maximum temperature increase of 26°C and assuming a fully confined condition. Results of this calculation indicate that short-term compressive thermal stresses in the concrete will be less than 9.2 MPa. The temperature rise in the surrounding salt is insignificant in terms of producing either detrimental or beneficial effects. Based on these results, the structural integrity of concrete components will not be compromised by thermoelastic stresses caused by heat of hydration.

7.4.1.4 Effect of Dynamic Compaction on Concrete Seals

The objective of this calculation was to determine a required thickness of seal layers above concrete components to reduce the impact of dynamic compaction. Compaction depths for crushed salt and clay layers are 2.8 m and 2.2 m, respectively. Layers 3.7-m thick for crushed salt and 3-m thick for clay are to be emplaced before compaction begins, thus providing a layer about 30% thicker than the calculated compaction depths.

7.4.1.5 Effect of Clay Swelling Pressures on Concrete Seals

The objective of this calculation was to determine the increased stresses within concrete components as a result of clay swelling pressures. Test measurements on confined bentonite at an emplaced density of 1.8 g/cm³ indicate that anticipated swelling pressures are on the order of 3.5 MPa. In order to fracture the salt surrounding the clay, the swelling pressures must exceed the lithostatic rock stress in the salt, which ranges from nominally 8.3 MPa at the upper clay seal to 14.4 MPa at the lower clay seal. The design strength of the concrete (31.0 MPa) is significantly greater than the swelling pressure of 3.5 MPa. Even in the unlikely event that the clay swelled to lithostatic pressures, the resulting state of stress in the concrete seal would lie well below any failure surface. Furthermore, the compressive tangential stress in the salt along the shaft wall, even after stress relaxation from creep, is always larger than lithostatic. Hence, radial fracturing from clay swelling pressure is not expected.

7.4.2 Crushed Salt Seals

Two analyses related to structural performance of crushed salt seals were performed, including (1) a structural analysis and (2) an analysis to determine effects of pore pressure on consolidation of crushed salt seals. This section presents the results of these analyses and evaluates the results in terms of performance of crushed salt seals. Details of these analyses are given in Appendix D in the Compliance Submittal Design Report (Sandia, 1996), Section D4.

7.4.2.1 Structural Analysis of Compacted Salt Seal

The objectives of this calculation were (1) to determine the fractional density of the crushed salt seal as a function of time and depth and, using these results, (2) to determine permeability of the crushed salt as a function of time and depth.

Results indicate that compacted salt will increase from its emplaced fractional density of 90% to a density of 95% approximately 40, 80, and 120 years after emplacement at the bottom, middle, and top of the shaft seal, respectively. Using the modified Sjaardema-Krieg creep consolidation model, the times required to fully reconsolidate the crushed salt to 100% fractional density are 70 years, 140 years, and 325 years at the bottom, middle, and top of the salt column, respectively. Based on these results, the desired fractional densities (hence, permeability) can be achieved over a substantial length of the compacted salt seal in the range of 50 to 100 years.

7.4.2.2 Pore Pressure Effects on Reconsolidation of Crushed Salt Seals

The objective of this calculation was to determine the effect of pore pressure on the reconsolidation of the crushed salt seal. Fractional densities of the crushed salt seal were calculated using the modified Sjaardema-Krieg consolidation model for a range of pore

pressures (0, 2, and 4 MPa). Results indicate that times required to consolidate the crushed salt increase as the pore pressure increases, as expected. For example, for a pore pressure of 2 MPa, the times required to achieve a fractional density of 96% are about 90 years, 205 years, and 560 years at the bottom, middle, and top of the crushed salt column, respectively. A pore pressure of 4 MPa would effectively prevent reconsolidation of the crushed salt within a reasonable period (<1,000 years). The results of this calculation were used in the fluid flow calculations, and the impact of these pore pressures on the permeability of the crushed salt seal is described in Section 8 and Appendix C of the Compliance Submittal Design Report (Sandia, 1996).

7.4.3 Compacted Clay Seals

One analysis was performed to determine the structural response of compacted clay seals. The objective of this calculation was to determine stresses in the upper Salado compacted clay component and the lower Salado compacted clay component as a result of creep of the surrounding salt. Details of this calculation are given in Appendix D in the Compliance Submittal Design Report (Sandia, 1996), Section D4. Results of this calculation indicate that after 50 years the compressive stresses in the upper Salado compacted clay component are about 0.7 MPa, not including the effects of swelling pressures. Similarly, after 50 years the stresses in the lower Salado compacted clay component are approximately 2.6 MPa. Based on these results, the compacted clay component will provide some restraint to the creep of salt and induce a back (radial) stress in the clay seal, which will promote healing of the DRZ in the surrounding intact salt (see discussion about DRZ in Section 7.5.1).

7.4.4 Asphalt Seals

Three analyses were performed related to structural performance of the asphalt seals, including (1) a thermal analysis, (2) a structural analysis, and (3) a shrinkage analysis. This section presents the results of these analyses and evaluates the results in terms of the performance of the asphalt seal. Details of these analyses are given in Appendix D of the Compliance Submittal Design Report (Sandia, 1996), Section D4.

7.4.4.1 Thermal Analysis

The objectives of this calculation were (1) to determine temperature histories within the asphalt seal and the surrounding salt and (2) to determine effects of the length of the waterstop.

Results indicate that the center of the asphalt column will cool from its emplaced temperature of 180°C to 83°C, 49°C, 31°C, and 26°C at times 0.1 year, 0.2 year, 0.5 year, and 1.0 year, respectively. Similarly, the asphalt/salt interface temperatures at corresponding times are 47°C, 38°C, 29°C, and 26°C. The time required for a waterstop to cool is significantly less than that required to cool the asphalt column. Based on these results, about 40 days are required for asphalt to cool to an acceptable working environment temperature. The thermal impact on enhanced creep rate of the surrounding salt is considered to be negligible.

7.4.4.2 Structural Analysis

The objective of this analysis was to calculate pressures in asphalt that result from restrained creep of the surrounding salt and to evaluate stresses induced on the concrete seal component by such pressurization.

Results indicate that pressures in the waterstops after 100 years are 1.8 MPa, 2.5 MPa, and 3.2 MPa for the upper, middle, and lower waterstops, respectively. Based on these results, the structural integrity of concrete components will not be compromised by imposed pressures, and the rock surrounding the asphalt will not be fractured by the pressure. The pressure from asphalt is enough to initiate healing of the DRZ surrounding the waterstop.

7.4.4.3 Shrinkage Analysis

The objective of this analysis was to calculate shrinkage of the asphalt column as it cools from its emplaced temperature to an acceptable working environment temperature. Results of this analysis indicate that the 42-m asphalt column will shrink 0.9 m in height as the asphalt cools from its emplaced temperature of 180°C to 38°C.

7.5 Disturbed Rock Zone Considerations

7.5.1 General Discussion of DRZ

Microfracturing leading to a DRZ occurs within salt whenever excavations are made. Laboratory and field measurements show that a DRZ has enhanced permeability. The body of evidence strongly suggests that induced fracturing is reversible and healed when deviatoric stress states created by the opening are reduced. Rigid seal components in the shaft provide a restraint to salt creep closure, thereby inducing healing stress states in the salt. A more detailed discussion of the DRZ is included in Appendix D in the Compliance Submittal Design Report (Sandia, 1996).

7.5.2 Structural Analyses

Three analyses were performed to determine the behavior of the DRZ in the rock mass surrounding the shaft. The first analysis considered time-dependent DRZ development and subsequent healing of intact Salado salt surrounding each of the four seal materials. The second analysis considered time-dependent development of the DRZ within anhydrite and polyhalite interbeds within the Salado Formation. The last analysis considered time-independent DRZ development within the near-surface and Rustler formations. These analyses are discussed below and given in more detail in Appendix D of the Compliance Submittal Design Report (Sandia, 1996), Section D5. Results from these analyses were used as input conditions for the fluid flow analysis presented in Section 8 and Appendix C of the Compliance Submittal Design Report (Sandia, 1996).

7.5.2.1 Salado Salt

The objective of this calculation was to determine time-dependent extent of the DRZ in salt, assuming no pore pressure effects, for each of the four shaft seal materials (i.e., concrete, crushed salt, compacted clay, and asphalt). The seal materials below a depth of about 300 m provide sufficient rigidity to heal the DRZ within 100 years. Asphalt, modeled as a weak elastic material, will not create a stress state capable of healing the DRZ because it is located high in the Salado.

7.5.2.2 Salado Anhydrite Beds

The objective of this calculation was to determine the extent of the DRZ within the Salado anhydrite and polyhalite interbeds as a result of creep of surrounding salt.

For all interbeds, the factor of safety against failure (shear or tensile fracturing) increases with depth into the rock surrounding the shaft wall. These results indicate that, with the exception of Marker Bed 117 (**MB117**), the factor of safety is greater than 1 (no DRZ will develop) for all interbeds. For MB117, the potential for fracturing is localized to within 1 m of the shaft wall.

7.5.2.3 Near-Surface and Rustler Formations

The objective of this calculation was to determine the extent of the DRZ surrounding the shafts in the near-surface and Rustler formations.

Rock types in near-surface and Rustler formations are anhydrite, dolomite, and mudstone. These rock types exhibit time-independent behavior. Results indicate that no DRZ will develop in anhydrite and dolomite (depths between 165 and 213 m). For mudstone layers, the radial extent of the DRZ increases with depth, reaching a maximum of 2.6 shaft radii at a depth of 223 m.

7.6 Other Analyses

This section discusses two structural analyses performed in support of design concerns, namely (1) the asphalt waterstops constructability and (2) benefits from shaft station backfilling. Analyses performed in support of these efforts are discussed below and given in more detail in Appendix D of the Compliance Submittal Design Report (Sandia, 1996), Section D6.

7.6.1 Asphalt Waterstops

The DRZ is a major contributor to fluid flows through a low permeability shaft seal system, regardless of the materials emplaced within the shaft. Therefore, to increase the confidence in the overall shaft seal, low permeability layers (termed radial waterstops) were included to intersect the DRZ surrounding the shaft. These waterstops are emplaced to alter the flow direction either inward toward the shaft seal or outward toward intact salt. Asphalt-filled waterstops will be effective soon after emplacement. The objectives of these structural calculations were to evaluate performance of the waterstops in terms of (1) intersecting the DRZ around the shaft, (2) inducing a new DRZ because of special excavation, and (3) promoting healing of the DRZ.

Results indicate that the DRZ from the shaft extends to a radial distance of less than one shaft radius (3.04 m). Waterstop excavation extends the DRZ radially to about 1.4 shaft radii (4.3 m). However, this extension is localized within the span of the concrete component and extends minimally past the waterstop edge. The DRZ extent reduced rapidly after the concrete and asphalt restrained creep of the surrounding salt. After 20 years, the spatial extent of the DRZ is localized near the asphalt-concrete interface, extending spatially into the salt at a distance of less than 2 m. Based on these results, construction of waterstops is possible without substantially increasing the DRZ. Furthermore, the waterstop extends well beyond the maximum extent of the DRZ surrounding the shaft and effectively blocks this flow path (within 2 years after emplacement), albeit over only a short length of the flow path.

7.6.2 Shaft Pillar Backfilling

The objective of this calculation was to assess potential benefits from backfilling a portion of the shaft pillar to reduce subsurface subsidence and thereby decrease the potential for inducing fractures along the shaft wall. The calculated subsidence without backfilling is less than one foot, due to the relatively low extraction ratio at the WIPP. Based on the results of this analysis, backfilling portions of the shaft pillar would result in only 10% to 20% reduction in surface subsidence. This reduction in subsidence from backfilling is not considered enough to warrant backfilling the shaft pillar area. The shaft seals within the Salado are outside the angle-of-draw for any horizontal displacements caused by the subsidence over the waste panels. Moreover, horizontal strains caused by subsidence induced by closures within the shaft pillar are compressive in nature and insignificant in magnitude to induce fracturing along the shaft wall.

8. Hydrologic Evaluation of the Shaft Seal System

8.1 Introduction

The design guidance in Section 3 presented the rationale for sealing the shaft seal system with low permeability materials, but it did not provide specific performance measures for the seal system. This section compares the hydrologic behavior of the system to several performance measures that are directly related to the ability of the seal system to limit liquid and gas flows through the seal system. The hydrologic evaluation is focused on the processes that could result in fluid flow through the shaft seal system and the ability of the seal system to limit any such flow. Transport of radiological or hazardous constituents will be limited if the carrier fluids are similarly limited.

The hydrologic performance models are fully described in Appendix C of the Compliance Submittal Design Report (Sandia, 1996). The analyses presented are deterministic. Quantitative values for those parameters that are considered uncertain and that may significantly impact the primary performance measures have been varied, and the results are presented in Appendix C of the Compliance Submittal Design Report (Sandia, 1996). This section summarizes the seal system performance analyses and discusses results within the context of the design guidance of Section 3. The results demonstrate that (1) fluid flows will be limited within the shaft seal system and (2) uncertainty in the conceptual models and parameters for the seal system are mitigated by redundancy in component function and materials.

8.2 Performance Models

The physical processes that could impact seal system performance are presented in detail in Appendix C of the Compliance Submittal Design Report (Sandia, 1996). These processes have been incorporated into four performance models. These models evaluate (1) downward migration of groundwater from the Rustler Formation, (2) gas migration and consolidation of the crushed salt seal component, (3) upward migration of brines from the repository, and (4) flow between water-bearing zones in the Rustler Formation. The first three are analyzed using numerical models of the Air Intake Shaft (AIS) seal system and the finite-difference codes SWIFT II and TOUGH28W. These codes are extensively used and well documented within the scientific community. A complete description of the models is provided in Appendix C of the Compliance Submittal Design Report (Sandia, 1996). The fourth performance model uses a simple, analytical solution for fluid flow. Results from the analyses are summarized in the following sections and evaluated in terms of the design guidance presented in Section 3.

Material properties and conceptual models that may significantly impact seal system performance have been identified, and uncertainty in properties and models have been addressed through variation of model parameters. These parameters include (1) the effective permeability of the DRZ, (2) those describing salt column consolidation and the relationship between compacted salt density and permeability, and (3) repository gas pressure applied at the base of the shaft seal system.

8.3 Downward Migration of Rustler Groundwater

The shaft seal system is designed to limit groundwater flowing into and through the shaft sealing system (see Section 3). The principal source of groundwater to the seal system is the Culebra Member of the Rustler Formation. The Magenta Member of this formation is also considered a

groundwater source, albeit a less significant source than the Culebra. No significant sources of groundwater exist within the Salado Formation; however, brine seepage has been noted at a number of the marker beds. The modeling includes the marker beds, as discussed in Appendix C of the Compliance Submittal Design Report (Sandia, 1996). Downward migration of Rustler groundwater must be limited so that liquid saturation of the compacted salt column salt column does not impact the consolidation process and to ensure that significant quantities of brine do not reach the repository horizon. Because it is clear that limitation of liquid flow into the salt column necessarily limits liquid flow to the repository, the volumetric flux of liquid into and through the salt column were selected as performance measures for this model.

Consolidation of the compacted salt column salt column will be most rapid immediately following seal construction. Simulations were conducted for the 200-year period following closure to demonstrate that, during this initial period, downward migration of Rustler groundwater will be insufficient to impact the consolidation process. Lateral migration of brine through the marker beds is also quantified in the analysis and shown to be nondetrimental to the function of the salt column.

8.3.1 Analysis Method

Seal materials will not, in general, be fully saturated with liquid at the time of construction. The host rock surrounding the shafts will also be partially desaturated at the time of seal construction. The analysis presented in this section assumes a fully saturated system. The effects of partial saturation of the shaft seal system are favorable in terms of system performance, as will be discussed in Section 8.3.2.

Seal material and host rock properties used in the analyses are discussed in Appendix C of the Compliance Submittal Design Report (Sandia, 1996), Section C3. Appendix G2-A contains a detailed discussion of seal material properties. A simple perspective on the effects of material and host rock properties may be obtained from Darcy's Law. At steady-state, the flow rate in a fully saturated system depends directly on the system permeability. The seal system consists of the component material and host rock DRZ. Low permeability is specified for the engineered materials; thus the system component most likely to impact performance is the DRZ. Rock mechanics calculations presented in Appendix D of the Compliance Submittal Design Report (Sandia, 1996) predict that the DRZ in the Salado Formation will not be vertically continuous because of the intermittent layers of stiff anhydrites (marker beds). Asphalt waterstops are included in the design to minimize DRZ impacts. The effects of the marker beds and the asphalt waterstops on limiting downward migration are explicitly simulated through variation of the permeability of the layers of Salado DRZ.

Initial, upper, and lateral boundary conditions for the performance model are consistent with field measurements for the physical system. At the base of the shaft a constant atmospheric pressure is assumed.

8.3.2 Summary of Results

The initial pore volumes in the filled repository and the AIS salt column are approximately 460,000 m³ and 250 m³, respectively. The performance model predicts a maximum cumulative flow of less than 5 m³ through the sealed shafts for the 200 years following closure. If the marker beds have a disturbed zone immediately surrounding the shaft, the maximum flow is less than 10 m³ during the same period. Assuming the asphalt waterstops are not effective in

interrupting the vertical DRZ, the volumetric flow increases but is still less than 30 m³ for the 200 years following closure. These volumes are less than 1/100 of 1% of the pore volume in the repository and less than 20% of the initial pore volume of the salt column.

Two additional features of the model predictions should also be considered. The first of these is that flow rates fall from less than 1 m³/year in the first five years to negligible values within 10 years of seal construction. Therefore most of the cumulative flow occurs within a few years following closure. The second feature is the model prediction that the system returns to nearly ambient undisturbed pressures within two years. The repressurization occurs quickly within the model due to the assumption of a fully saturated flow regime because of brine incompressibility. As will be discussed in Section 8.4, the pore pressure in the compacted salt column is a critical variable in the analysis. The pressure profiles predicted by the model are an artifact of the assumption of full liquid saturation and do not apply to the pore pressure analysis of the salt column.

The magnitude of brine flow that can reach the repository through a sealed shaft is minimal and will not impact repository performance. The flow that reaches the salt column must be assessed with regard to the probable impacts on the consolidation process. Although the volume of flow to the salt column is a small percentage of the available pore volume, the saturation state and fluid pore pressure of this component are the variables of significance. These issues cannot be addressed by a fully saturated model. Instead it is necessary to include these findings in a multi-phase model that includes the salt column. This is the topic of Section 8.4.

The results of the fully saturated model will over-predict the flow rates through the sealed shaft. This analysis does not take credit for the time required for the system to resaturate, nor does it take credit for the sorptive capabilities of the clay components. The principal source of groundwater to the system is the Rustler Formation. The upper clay component is located below the Rustler and above the salt column and will be emplaced at a liquid saturation state of approximately 80%. Bentonite clays exhibit strong hydrophilic characteristics, and it is expected that the upper clay component will have these same characteristics. As a result, it is possible that a significant amount of the minimal Rustler groundwater that reaches the clay column will be absorbed and retained by this seal component. Although this effect is not directly included in the present analysis, the installation of a partially saturated clay component provides assurance that the flow rates predicted by the model are maximum values.

8.4 Gas Migration and Consolidation of Compacted Salt Column

The seal system is designed to limit the flow of gas from the disposal system through the sealed shafts. Migration of gas could impact performance if this migration substantially increases the fluid pore pressure of the compacted salt column. The initial pore pressure of the salt column will be approximately atmospheric. The sealed system will interact with the adjacent desaturated host rock as well as the far-field formation. Natural pressurization will occur as the system returns to an equilibrium state. This pressurization, coupled with seepage of brine through the marker beds, will also result in increasing fluid pore pressure within the compacted salt column. The analysis presented in this section addresses the issue of fluid pore pressure in the compacted salt column resulting from the effects of gas generation at the repository horizon and natural repressurization from the surrounding formation. A brief discussion on the impedance to gas flow afforded by the lower compacted clay column is also presented.

8.4.1 Analysis Method

A multi-phase flow model of the lower seal system was developed to evaluate the performance of components extending from the middle SMC component to the repository horizon. Rock mechanics calculations presented in Section 7 and Appendix D of the Compliance Submittal Design Report (Sandia, 1996) predict that the compacted salt column will consolidate for a period of approximately 400 years if the fluid-filled pores of the column do not produce a backstress. Within the physical setting of the compacted salt column, three processes have been identified which may result in a significant increase in pore pressure: groundwater flow from the Rustler Formation, gas migration from the repository, and natural fluid flow and repressurization from the Salado Formation. The first two processes were incorporated into the model as initial and boundary conditions, respectively. The third process was captured in all simulations through modeling of the lithologies surrounding the shaft. Simulations were conducted for 200 years following closure to evaluate any effects these processes might have on the salt column during this initial period.

As discussed in Section 8.3.1, the host rock DRZ is an important consideration in seal system performance. A vertically continuous DRZ could exist in both the Rustler and Salado Formations. Concrete-asphalt waterstops are included in the design to add assurance that a DRZ will not adversely impact seal performance. The significance of a continuous DRZ and waterstops will be evaluated based on results of the performance model.

A detailed description of the model grid, assumptions, and parameters is presented in Appendix C of the Compliance Submittal Design Report (Sandia, 1996).

8.4.2 Summary of Results

The consolidation process is a function of both time and depth. The resultant permeability of the compacted salt column will similarly vary. To simplify the evaluation, an effective permeability of the salt component was calculated. This permeability is calculated by analogy to electrical circuit theory. The permeability of each model layer is equated to a resistor in a series of resistors. The equivalent resistance (i.e., permeability) of a homogeneous column of identical length is derived in this manner. Figure G2-11 illustrates this process.

Results of the performance model simulations are summarized in Table G2-12. The effective permeabilities were calculated by the model assuming that, as the salt consolidated, permeability was reduced pursuant to the best-fit line through the experimental data (Appendix G2-A, Figure G2A-7). From Table G2-12 it is clear that, for all simulated conditions, the salt column consolidates to very low values in 200 years. Differences in the effective permeability because of increased repository gas pressure and a vertically continuous DRZ were negligible. The DRZ around concrete components is predicted to heal (Appendix D of the Compliance Submittal Design Report (Sandia, 1996)) within 25 years. If the asphalt waterstops do not function as intended, the DRZ in this region will still heal in 25 years, as compared to 2 years for effective waterstops. The effective permeability of the compacted salt column increases by about a factor of two for this condition. However, the resultant permeability is sufficiently low that the compacted salt columns will comprise permanent effective seals within the WIPP shafts.

Table G2-12
Summary of Results from Performance Model

Repository Pressure	Rustler Flow (m ³)	Continuous DRZ (Yes/No)	Concrete-Asphalt Waterstop Healing Time (Years)	Effective Permeability at 200 Years (m ²)
7 MPa in 100 Years	0	No	2	3.3×10 ⁻²⁰
14 MPa in 200 Years	0	No	2	3.3×10 ⁻²⁰
7 MPa in 100 Years	2.7	Yes	2	3.4×10 ⁻²⁰
7 MPa in 100 Years	17.2	Yes	25	6.0×10 ⁻²⁰

The relationship between the fractional density (i.e., consolidation state) of the compacted salt column and permeability is uncertain, as discussed in Appendix G2-A. Lines drawn through the experimental data (Figure A-7) provide a means to quantify this uncertainty but do not capture the actual physical process of consolidation. As observed through microscopy, consolidation is dominated by pressure solution and redeposition, a mechanism of mass movement facilitated by the presence of moisture on grain boundaries (Hansen and Ahrens, 1996). As this process continues, the connected porosity and hence permeability of the composite mass will reduce at a rate that has not been characterized by the data collected in WIPP experiments. The results of the multi-phase performance model presented in Table G2-12 used a best-fit line through the data. Additional simulations were conducted using a line that represents a 95% certainty that the permeability is less than or equal to values taken from this line. Model simulations that used the 95% line are not considered representative of the consolidation process. However, these results provide an estimation of the significance that this uncertainty may have on the seal system performance.

Figure G2-12 depicts the effective permeability of the salt column as a function of time using the 95% line. The consolidation process, and hence permeability reduction, essentially stopped at 75 years for this simulation. Although the model predicts that the fractional density at the base of the salt column will reach approximately 97% of the density of intact halite, the permeability remains several orders of magnitude higher than that of the surrounding host rock. As a result, repressurization occurs rapidly throughout the vertical extent of the compacted salt column, and consolidation ceases. Laboratory experiments have shown that permeability to brine should decrease to levels of 10⁻¹⁸ to 10⁻²⁰ m² at the fractional densities predicted by the performance model. The transport of brine within the consolidating salt will reduce the permeability even further (Brodsky et al., 1995). The predicted permeability of 10⁻¹⁶ m² is still sufficiently low that brine migration would be limited (DOE, 1995). However, the results of this analysis are more valuable in terms of demonstrating the coupled nature of the mechanical and hydrological behavior of consolidating crushed salt.

A final consideration within this performance model relates to the lower compacted clay column. This clay column is included in the design to provide a barrier to both gas and brine migration from the repository horizon. The ability of the clay to prevent gas migration will depend upon its liquid saturation state (Section 5 and Appendix G2-A). The lower clay component has an initial liquid saturation of about 80%, and portions of the column achieve brine saturations of nearly 100% during the 200 year simulation period. If the clay component performs as designed, gas migration through this component should be minimal. An examination of the model gas saturations indicates that, for all runs, gas flow occurs primarily through the DRZ prior to

healing. These model predictions are consistent with field demonstrations that brine-saturated bentonite seals will prevent gas flow at differential pressures of up to 4 MPa (Knowles and Howard, 1996).

8.5 Upward Migration of Brine

The performance model discussed in Section 8.3 was modified to simulate undisturbed equilibrium pressures. As discussed in Appendix C of the Compliance Submittal Design Report (Sandia, 1996), the Salado Formation is overpressurized with respect to the measured heads in the Rustler, and upward migration of contaminated brines could occur through an inadequately sealed shaft. Sections 8.3 and 8.4 demonstrated that the compacted salt column will consolidate to a low permeability following repository closure. Appendix D of the Compliance Submittal Design Report (Sandia, 1996) and Section 7 show that the DRZ surrounding the long-term clay and crushed salt seal components will completely heal within the first several decades. As a result, upward migration at the base of the Salado salt is predicted to be approximately 1 m³ over the regulatory period. At the Rustler/Salado contact, a total of approximately 20 m³ migrates through the sealed AIS over the regulatory period. The only brine sources between these two depths are the marker beds. It can therefore be concluded that most of the brine flow reaching the Rustler/Salado contact originates in marker beds above the repository horizon. The seal system effectively limits the flow of brine and gas from the repository through the sealed shafts throughout the regulatory period.

8.6 Intra-Rustler Flow

The potential exists for vertical flow within water-bearing strata of the Rustler Formation. Flow rates were estimated using a closed form solution of the steady-state saturated flow equation (Darcy's Law). The significance of the calculated flow rates can be assessed in terms of the width of the hydraulic disturbance (i.e., plume half-width) generated in the recipient flow field. The plume half-width was calculated to be minimal for all expected conditions (Compliance Submittal Design Report (Sandia, 1996), Section C7). Intra-Rustler flow is therefore concluded to be of such a limited quantity that (1) it will not affect either the hydraulic or chemical regime in the Rustler and (2) it will not be detrimental to the seal system.

9. Conclusions

The principal conclusion drawn from discussions in the previous sections and details provided in the appendices is that an effective, implementable design has been documented for the WIPP shaft sealing system. Specifically, the six elements of the Design Guidance, Table G2-12, are implemented in the design in the following manner:

1. The shaft sealing system shall limit the migration of radiological or other hazardous constituents from the repository horizon to the regulatory boundary during the 10,000-year regulatory period following closure.

Based on the analysis presented in Section 8.5, it was determined that this shaft sealing system effectively limits the migration of radiological or other hazardous constituents from the repository horizon to the regulatory boundary during the 10,000-year regulatory period following closure.

2. The shaft sealing system shall limit groundwater flowing into and through the shaft sealing system.

The combination of the seal components in the Salado Formation, the Rustler Formation, and above the Rustler combine to produce a robust system. Based on analysis presented in Section 8.3, it was concluded that the magnitude of brine flow that can reach the repository through the sealed shaft is minimal and will not impact repository performance.

3. The shaft sealing system shall limit chemical and mechanical incompatibility of seal materials with the seal environment.

The sealing system components are constructed of materials possessing high durability and compatibility with the host rock. Engineered materials including salt-saturated concrete, bentonite, clays, and asphalt are expected to retain their design properties over the regulatory period.

4. The shaft sealing system shall limit the possibility for structural failure of individual components of the sealing system.

Analysis of components has determined that: (a) the structural integrity of concrete components will not be compromised by induced radial stress, imposed vertical stress, temperature gradients, dynamic compaction of overlying materials, or swelling pressure associated with bentonite (Section 7.4.1); (b) the thermal impact of asphalt on the creep rate of the salt surrounding the asphalt waterstops is negligible (Section 7.4.4); and (c) the pressure from the asphalt element of the concrete-asphalt waterstops is sufficient to initiate healing of the surrounding DRZ within two years of emplacement (Section 7.6.1). The potential for structural failure of sealing components is minimized by the favorable compressive stress state that will exist in the sealed WIPP shafts.

5. The shaft sealing system shall limit subsidence of the ground surface in the vicinity of the shafts and the possibility of accidental entry after sealing.

The use of high density sealing materials that completely fill the shafts eliminates the potential for shaft wall collapse, eliminates the possibility of accidental entry after closure, and assures that local surface depressions will not occur at shaft locations.

6. The shaft sealing system shall limit the need to develop new technologies or materials for construction of the shaft sealing system.

The shaft sealing system utilizes existing construction technologies (identified in Section 6) and materials (identified in Section 5).

The design guidance can be summarized as focusing on two principal questions: Can you build it, and will it work? The use or adaptation of existing technologies for the placement of the seal components combined with the use of available, common materials assure that the design can be constructed. Performance of the sealing system has been demonstrated in the hydrologic analyses that show very limited flows of gas or brine, in structural analyses that assure acceptable stress and deformation conditions, and in the use of low permeability materials that will function well in the environment in which they are placed. Confidence in these conclusions is bolstered by the basic design approach of using multiple components to perform each intended sealing function and by using extensive lengths within the shafts to effect a sealing system. Additional confidence is added by the results of field and lab tests in the WIPP environment that support the data base for the seal materials.

10. References

Ahrens, E. H., and F. D. Hansen. 1995. *Large-Scale Dynamic Compaction Demonstration Using WIPP Salt: Fielding and Preliminary Results*. SAND95-1941. Albuquerque, NM: Sandia National Laboratories. (Copy on file in the Sandia WIPP Central Files, Sandia National Laboratories, Albuquerque, NM [SWCF] as WPO31104.)

Ahrens, E. H., and M. Onofrei. 1996. "Ultrafine Cement Grout for Sealing Underground Nuclear Waste Repositories," *2nd North American Rock Mechanics Symposium (NARMS 96), Montreal, Quebec, June 19-21, 1996*. SAND96-0195C. Albuquerque, NM: Sandia National Laboratories. (Copy on file in the SWCF as WPO31251.)

Ahrens, E. H., T. F. Dale, and R. S. Van Pelt. 1996. *Data Report on the Waste Isolation Pilot Plant Small-Scale Seal Performance Test, Series F Grouting Experiment*. SAND93-1000. Albuquerque, NM: Sandia National Laboratories. (Copy on file in the SWCF as WPO37355.)

Andersen, P. J., M.E. Andersen, and D. Whiting. 1992. *A Guide to Evaluating Thermal Effects in Concrete Pavements*. SHRP-C/FR-92-101. Washington, DC: Strategic Highway Research Program, National Research Council. (Copy on file in the SWCF.)

Avis, J.D., and G. J. Saulnier, Jr. 1990. *Analysis of the Fluid-Pressure Responses of the Rustler Formation at H-16 to the Construction of the Air-Intake Shaft at the Waste Isolation Pilot Plant (WIPP) Site*. SAND89-7067. Albuquerque, NM: Sandia National Laboratories. (Copy on file in the SWCF as WPO24168.)

Bachman, G. O. 1987. *Karst in Evaporites in Southeastern New Mexico*. SAND86-7078. Albuquerque, NM: Sandia National Laboratories. (Copy on file in the SWCF as WPO24006.)

Beauheim, R. L. 1987. *Interpretations of Single-Well Hydraulic Tests Conducted at and Near the Waste Isolation Pilot Plant (WIPP) Site, 1983-1987*. SAND87-0039. Albuquerque, NM: Sandia National Laboratories. (Copy on file in the SWCF as WPO27679.)

Beauheim, R. L., R. M. Roberts, T. F. Dale, M.D. Fort, and W. A. Stensrud. 1993. *Hydraulic Testing of Salado Formation Evaporites at the Waste Isolation Pilot Plant Site: Second Interpretive Report*. SAND92-0533. Albuquerque, NM: Sandia National Laboratories. (Copy on file in the SWCF as WPO23378.)

Brinster, K.F. 1991. *Preliminary Geohydrologic Conceptual Model of the Los Medaños Region Near the Waste Isolation Pilot Plant for the Purpose of Performance Assessment*. SAND89-7147. Albuquerque, NM: Sandia National Laboratories. (Copy on file in the SWCF as WPO27781.)

Brodsky, N. S. 1994. *Hydrostatic and Shear Consolidation Tests with Permeability Measurements on Waste Isolation Pilot Plant Crushed Salt*. SAND93-7058. Albuquerque, NM: Sandia National Laboratories.

Brodsky, N. S., D. H. Zeuch, and D. J. Holcomb. 1995. "Consolidation and Permeability of Crushed WIPP Salt in Hydrostatic and Triaxial Compression," *Rock Mechanics Proceedings of the 35th U.S. Symposium, University of Nevada, Reno, NV, June 5-7, 1995*. Eds. J. J. K.

Daemen and R.A. Schultz. Brookfield, VT: A. A. Balkema. 497-502. (Copy on file in the SWCF as WPO22432.)

Brodsky, N. S., F. D. Hansen, and T. W. Pfeifle. 1996. "Properties of Dynamically Compacted WIPP Salt," *4th International Conference on the Mechanical Behavior of Salt, Montreal, Quebec, June 17-18, 1996*. SAND96-0838C. Albuquerque, NM: Sandia National Laboratories. (Copy on file at the Technical Library, Sandia National Laboratories, Albuquerque, NM.)

Callahan, G. D., M. C. Loken, L. D. Hurtado, and F. D. Hansen. 1996. "Evaluation of Constitutive Models for Crushed Salt," *4th International Conference on the Mechanical Behavior of Salt, Montreal, Quebec, June 17-18, 1996*. SAND96-0791C. Albuquerque, NM: Sandia National Laboratories. (Copy on file in the SWCF as WPO36449.)

Cauffman, T. L., A.M. LaVenue, and J.P. McCord. 1990. *Ground-Water Flow Modeling of the Culebra Dolomite. Volume II: Data Base*. SAND89-7068/2. Albuquerque, NM: Sandia National Laboratories. (Copy on file in the SWCF as WPO10551.)

Dale, T., and L. D. Hurtado. 1996. "WIPP Air-Intake Shaft Disturbed-Rock Zone Study," *4th International Conference on the Mechanical Behavior of Salt, Montreal, Quebec, June 17-18, 1996*. SAND96-1327C. Albuquerque, NM: Sandia National Laboratories. (Copy on file in the SWCF.)

DOE (U.S. Department of Energy). 1995. *Waste Isolation Pilot Plant Sealing System Design Report*. DOE/WIPP-95-3117. Carlsbad, NM: U.S. Department of Energy, Waste Isolation Pilot Plant. (Copy on file in the SWCF as WPO29062.)

EPA (Environmental Protection Agency). 1996a. *Criteria for the Certification and Re-Certification of the Waste Isolation Pilot Plant's Compliance with the 40 CFR Part 191 Disposal Regulations. Response to Comments Document for 40 CFR Part 194*. EPA 402-R-96-001. Washington, DC: U.S. Environmental Protection Agency, Office of Radiation and Indoor Air. (Copy on file in the Nuclear Waste Management Library, Sandia National Laboratories, Albuquerque, NM.)

EPA (Environmental Protection Agency). 1996b. *Criteria for the Certification and Re-Certification of the Waste Isolation Pilot Plant's Compliance with the 40 CFR Part 191 Disposal Regulations. Background Information Document for 40 CFR Part 194*. EPA 402-R-96-002. Washington, DC: U.S. Environmental Protection Agency, Office of Radiation and Indoor Air. (Copy on file in the Nuclear Waste Management Library, Sandia National Laboratories, Albuquerque, NM.)

Gray, M. N. 1993. *OECD/NEA International Stripa Project. Overview Volume III: Engineered Barriers*. Stockholm, Sweden: SKB, Swedish Nuclear Fuel and Waste Management Company. (Copy on file in the Nuclear Waste Management Library, Sandia National Laboratories, Albuquerque, NM as TD898.2 .G73 1993.)

Hansen, F. D., and E. H. Ahrens. 1996. "Large-Scale Dynamic Compaction of Natural Salt," *4th International Conference on the Mechanical Behavior of Salt, Montreal, Quebec, June 17-18, 1996*. SAND96-0792C. Albuquerque, NM: Sandia National Laboratories. (Copy on file in the SWCF as WPO39544.)

Hansen, F. D., E. H. Ahrens, A. W. Dennis, L. D. Hurtado, M. K. Knowles, J. R. Tillerson, T. W. Thompson, and D. Galbraith. 1996. "A Shaft Seal System for the Waste Isolation Pilot Plant," *Proceedings of SPECTRUM '96, Nuclear and Hazardous Waste Management, International Topical Meeting, American Nuclear Society/Department of Energy Conference, Seattle, WA, August 18-23, 1996*. SAND96-1100C. Albuquerque, NM: Sandia National Laboratories. (Copy on file in the SWCF as WPO39369.)

Haug, A., V.A. Kelley, A.M. LaVenue, and J. F. Pickens. 1987. *Modeling of Ground-Water Flow in the Culebra Dolomite at the Waste Isolation Pilot Plant (WIPP) Site: Interim Report*. SAND86-7167. Albuquerque, NM: Sandia National Laboratories. (Copy on file in the SWCF as WPO28486.)

Hills, J. M. 1984. "Sedimentation, Tectonism, and Hydrocarbon Generation in [the] Delaware Basin, West Texas and Southeastern New Mexico," *American Association of Petroleum Geologists Bulletin*. Vol. 68, no. 3, 250-267. (Copy on file in the SWCF.)

Holt, R. M., and D. W. Powers. 1990. *Geologic Mapping of the Air Intake Shaft at the Waste Isolation Pilot Plant*. DOE-WIPP 90-051. Carlsbad, NM: Westinghouse Electric Corporation for U.S. Department of Energy. (Copy on file in the Nuclear Waste Management Library, Sandia National Laboratories, Albuquerque, NM.)

Knowles, M. K., and C. L. Howard. 1996. "Field and Laboratory Testing of Seal Materials Proposed for the Waste Isolation Pilot Plant," *Proceedings of the Waste Management 1996 Symposium, Tucson, AZ, February 25-29, 1996*. SAND95-2082C. Albuquerque, NM: Sandia National Laboratories. (Copy on file in the SWCF as WPO30945.)

Knowles, M. K., D. Borns, J. Fredrich, D. Holcomb, R. Price, D. Zeuch, T. Dale, and R. S. Van Pelt. 1996. "Testing the Disturbed Zone Around a Rigid Inclusion in Salt," *4th Conference on the Mechanical Behavior of Salt, Montreal, Quebec, June 17-18, 1996*. SAND95-1151C. Albuquerque, NM: Sandia National Laboratories. (Copy on file in the SWCF.)

Lambert, S. J. 1992. "Geochemistry of the Waste Isolation Pilot Plant (WIPP) Site, Southeastern New Mexico, U.S.A.," *Applied Geochemistry*. Vol. 7, no. 6, 513-531. (Copy on file in the SWCF as WPO26361.)

LaVenue, A.M., T. L. Cauffman, and J. F. Pickens. 1990. *Ground-Water Flow Modeling of the Culebra Dolomite. Volume I: Model Calibration*. SAND89-7068/1. Albuquerque, NM: Sandia National Laboratories. (Copy on file in the SWCF as WPO24085.)

Mercer, J. W. 1983. *Geohydrology of the Proposed Waste Isolation Pilot Plant Site, Los Medanos Area, Southeastern New Mexico*. Water-Resources Investigations Report 83-4016. Albuquerque, NM: U.S. Geological Survey, Water Resources Division. (Copy on file in the Nuclear Waste Management Library, Sandia National Laboratories, Albuquerque, NM.) (Copy on file in the SWCF.)

Mercer, J. W., and B. R. Orr. 1979. *Interim Data Report on the Geohydrology of the Proposed Waste Isolation Pilot Plant Site, Southeast New Mexico*. Water-Resources Investigations Report 79-98. Albuquerque, NM: U.S. Geological Survey, Water Resources Division. (Copy on file in the SWCF.)

Nowak, E. J., J. R. Tillerson, and T. M. Torres. 1990. *Initial Reference Seal System Design: Waste Isolation Pilot Plant*. SAND90-0355. Albuquerque, NM: Sandia National Laboratories. (Copy on file in the SWCF as WPO23981.)

Pfeifle, T. W., F. D. Hansen, and M. K. Knowles. 1996. "Salt-Saturated Concrete Strength and Permeability," *4th Materials Engineering Conference, ASCE Materials Engineering Division, Washington, DC, November 11-18, 1996*. Albuquerque, NM: Sandia National Laboratories.)

Powers, D. W., S. J. Lambert, S-E. Shaffer, L. R. Hill, and W. D. Weart, eds. 1978. *Geological Characterization Report Waste Isolation Plant (WIPP) Site, Southeastern New Mexico*. SAND78-1596. Albuquerque, NM: Sandia National Laboratories. Vols. I-II. (Copy on file in the SWCF as WPO5448, WPO26829-26830.)

Sandia (Repository Isolation Systems Department 6121). 1996. *Waste Isolation Pilot Plant Shaft Sealing System Compliance Submittal Design Report*. SAND96-1326/1&2. Albuquerque, NM: Sandia National Laboratories.

Saulnier, G. J., Jr., and J.D. Avis. 1988. *Interpretation of Hydraulic Tests Conducted in the Waste-Handling Shaft at the Waste Isolation Pilot Plant (WIPP) Site*. SAND88-7001. Albuquerque, NM: Sandia National Laboratories. (Copy on file in the SWCF as WPO24164.)

Stormont, J.C. 1984. *Plugging and Sealing Program for the Waste Isolation Pilot Plant (WIPP)*. SAND84-1057. Albuquerque, NM: Sandia National Laboratories. (Copy on file in the SWCF as WPO24698.)

Van Sambeek, L.L., D. D. Luo, M.S. Lin, W. Ostrowski, and D. Oyenuga. 1993. *Seal Design Alternatives Study*. SAND92-7340. Albuquerque, NM: Sandia National Laboratories. (Copy on file in the SWCF as WPO23445.)

Vine, J.D. 1963. *Surface Geology of the Nash Draw Quadrangle, Eddy County, New Mexico*. Geological Survey Bulletin 1141-B. Washington, DC: U.S. Government Printing Office. (Copy on file in the SWCF as WPO39558.)

Wing, N. R., and G. W. Gee. 1994. "Quest for the Perfect Cap," *Civil Engineering*. Vol. 64, no. 10, 38-41. (Copy on file in the SWCF as WPO21158.)

FIGURES

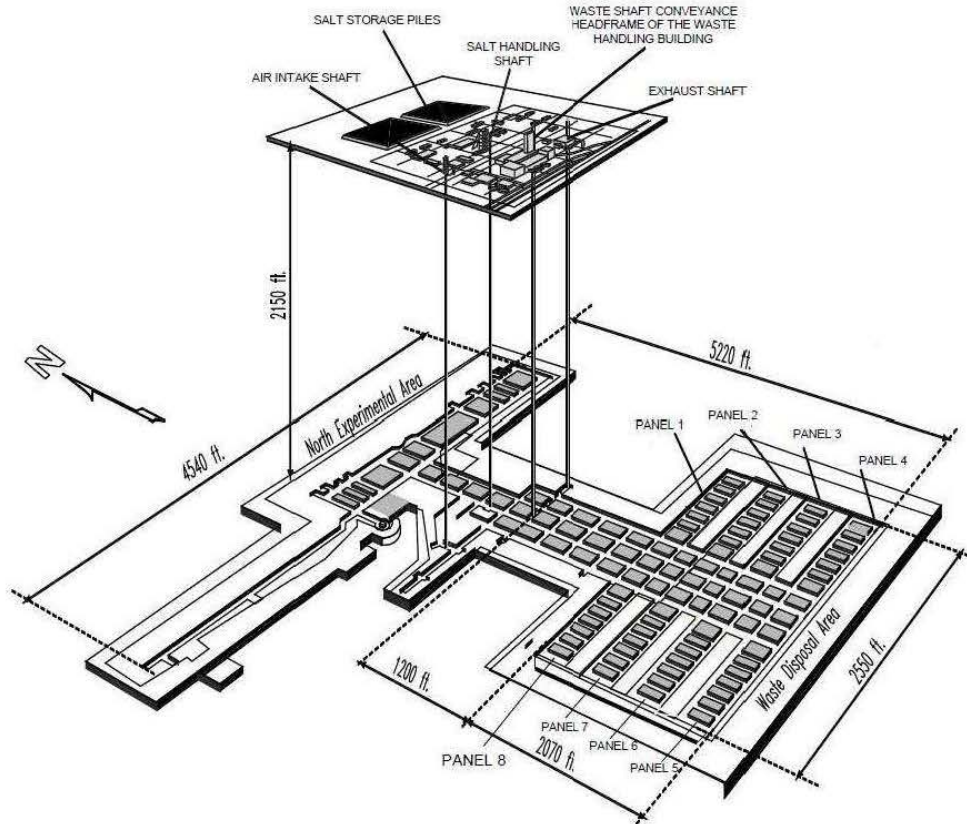
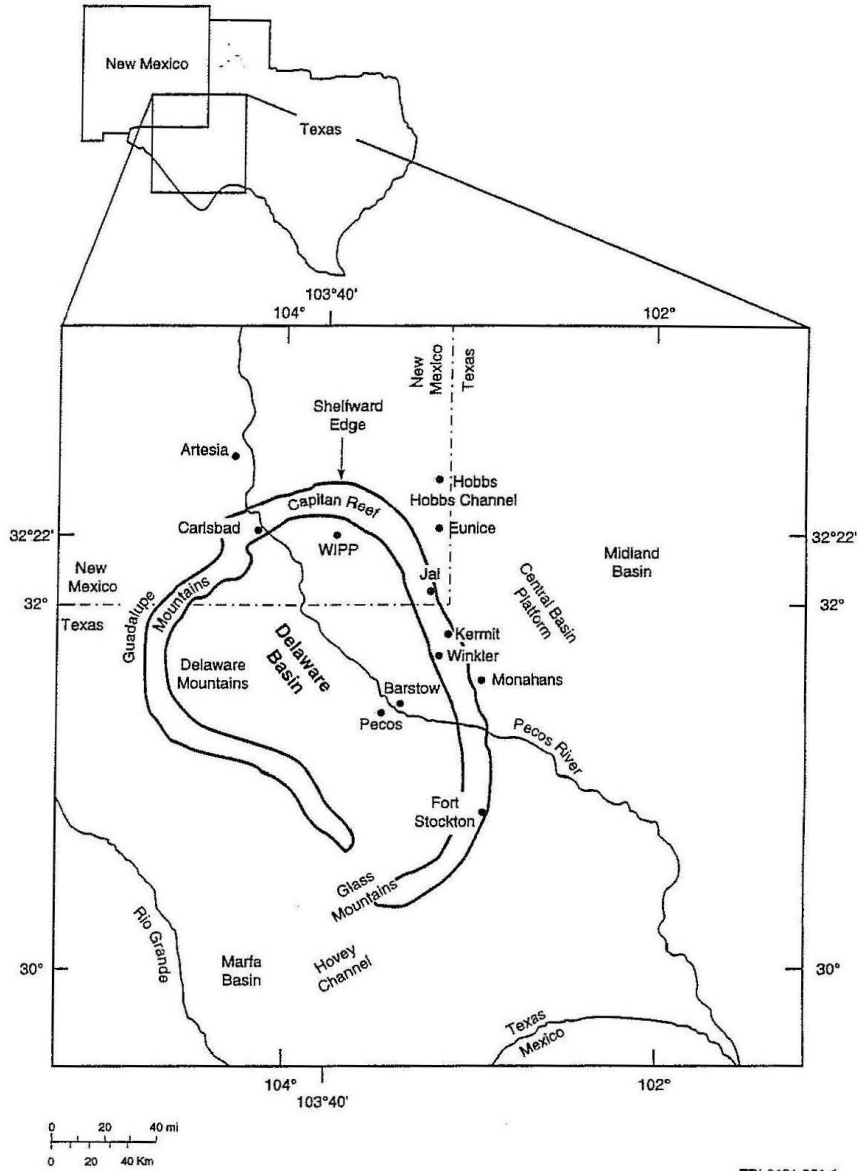

Figure G2-1
View of the WIPP Underground Facility



TRI-6121-351-1

Figure G2-2
Location of the WIPP in the Delaware Basin

Erathem	System	Series	Lithostratigraphic Unit	Age Estimate (yr)	
Cenozoic	Quaternary	Holocene	Windblown sand		
		Pleistocene	Mescalero caliche	~500,000	
			Gatuña Formation	~600,000	
	Tertiary	Pliocene		Ogallala Formation	5.5 million
					24 million
		Miocene		Absent in southeastern New Mexico	
					66 million
		Cretaceous	Upper	Absent in southeastern New Mexico	
			Lower	Detritus preserved	144 million
Mesozoic	Jurassic		Absent in southeastern New Mexico	208 million	
	Triassic	Upper	Dockum Group		
	Lower	Absent in southeastern New Mexico	245 million		
Paleozoic	Upper Permian	Ochoan	Dewey Lake Redbeds Rustler Formation Salado Formation Castile Formation		
		Guadalupian		Capitan Limestone and Bell Canyon Formation	
	Lower Permian	Leonardian	Bone Springs		
		Wolfcampian	Wolfcamp (informal)	286 million	

Modified from Bachman, 1987

Figure G2-3
Chart Showing Major Stratigraphic Divisions, Southeastern New Mexico

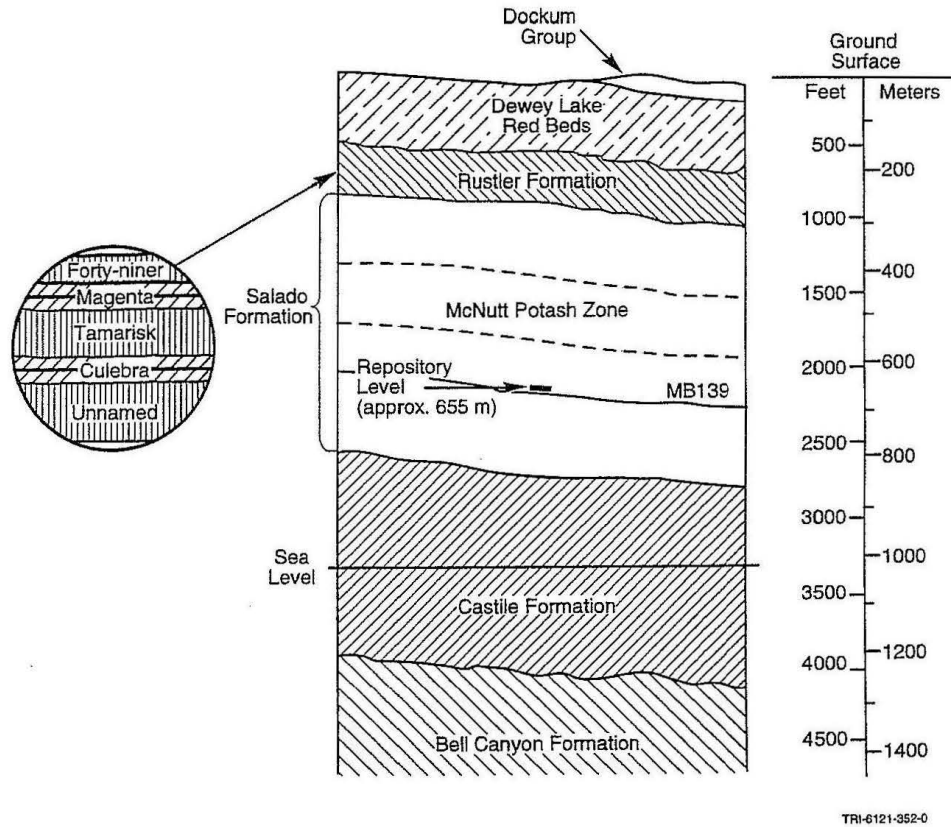
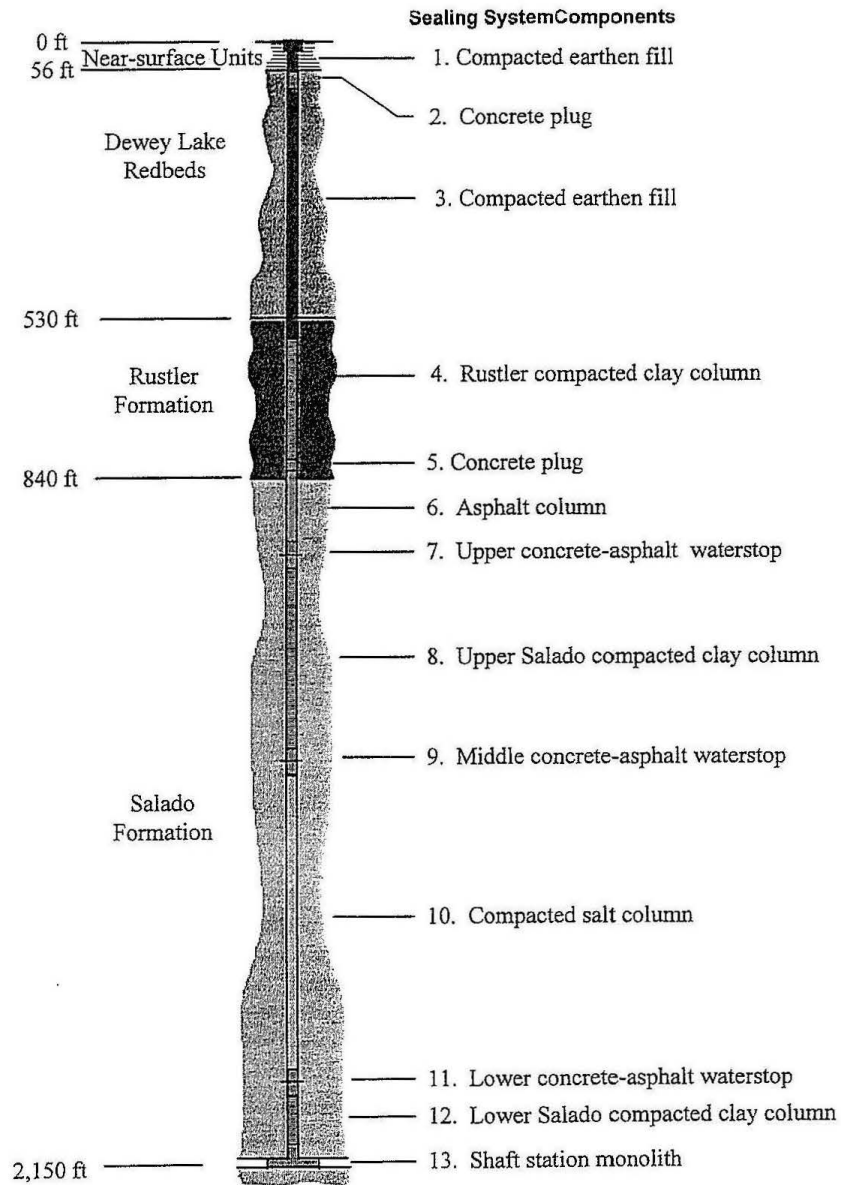

Figure G2-4
Generalized Stratigraphy of the WIPP Site Showing Repository Level



**Figure G2-5
 Arrangement of the Air Intake Shaft Sealing System**

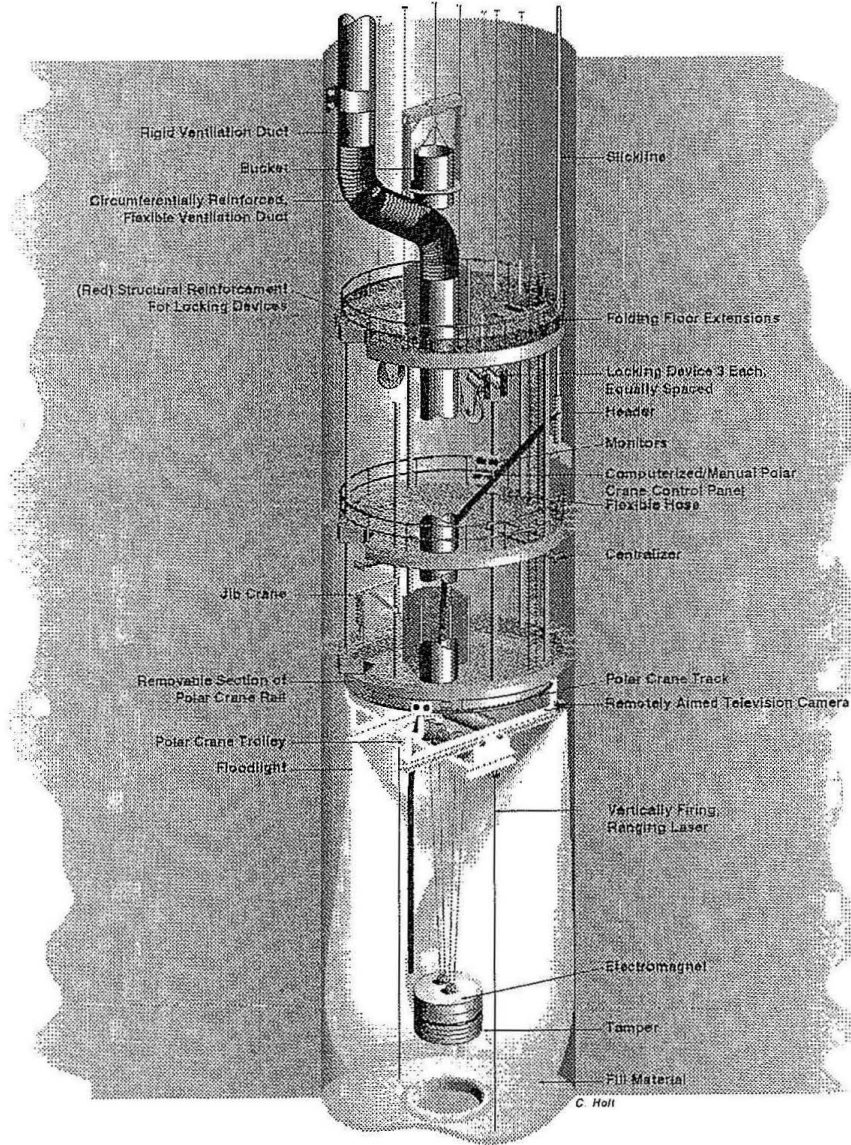

Figure G2-6
Multi-deck Stage Illustrating Dynamic Compaction

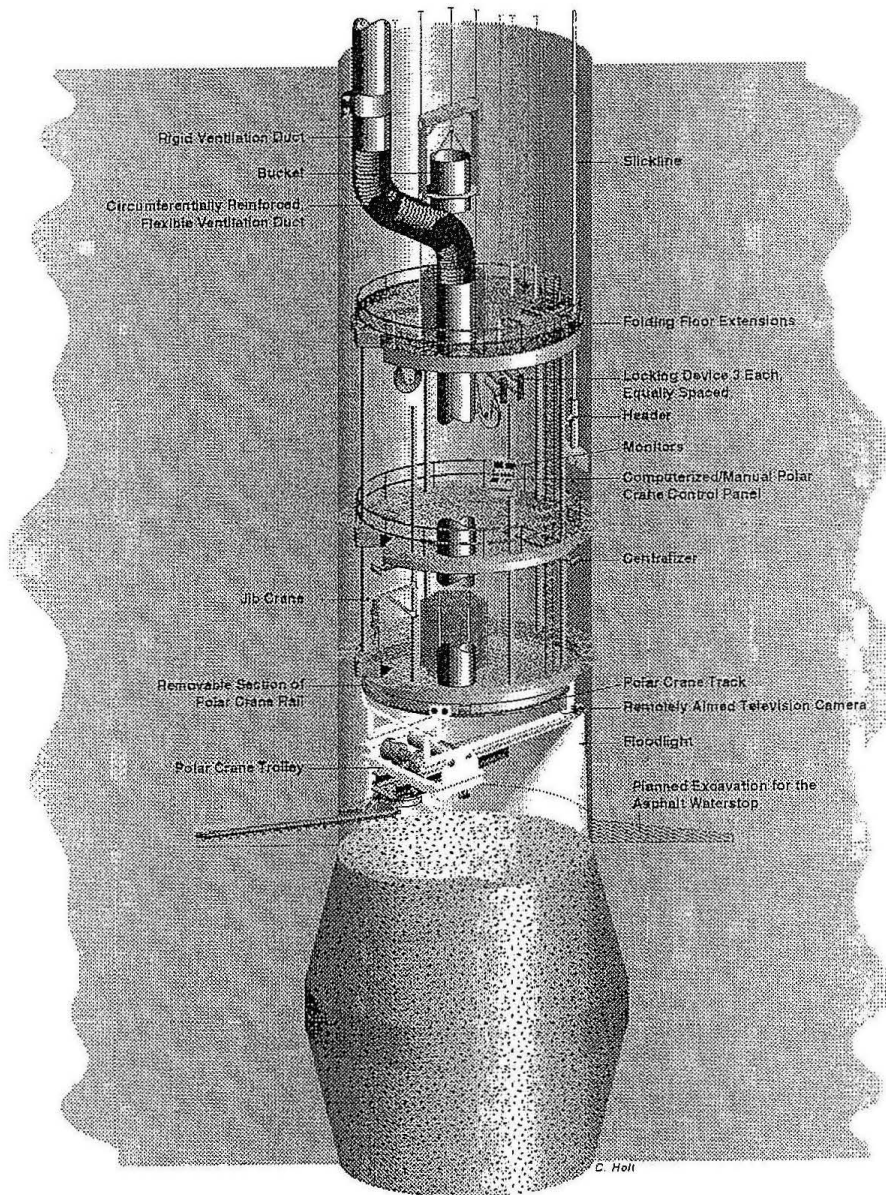
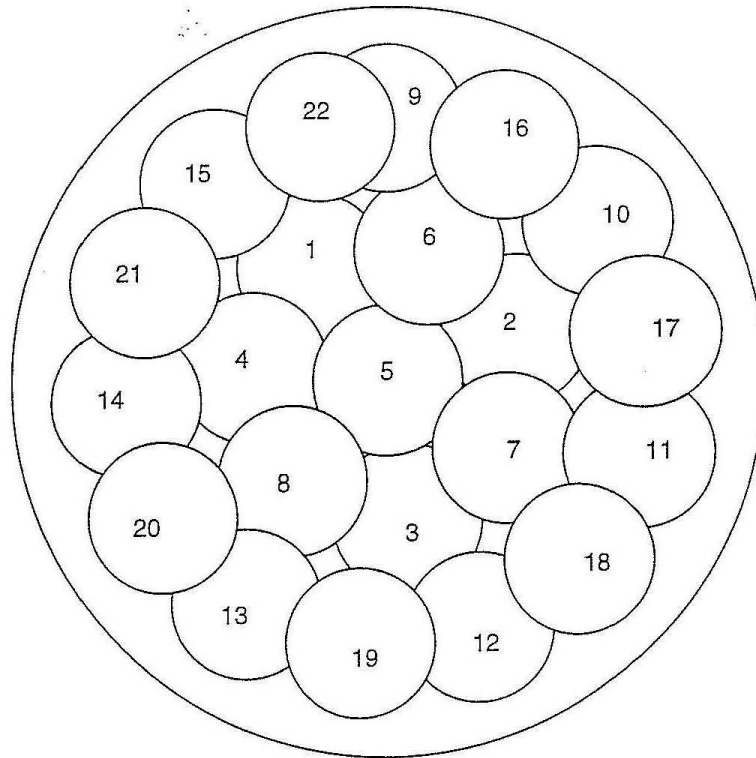

Figure G2-7
Multi-deck Stage Illustrating Excavation for Asphalt Waterstop



Scale: 1" = 4'

TRI-6121-376-0

Figure G2-8
Drop Pattern for 6-m-Diameter Shaft Using a 1.2-m-Diameter Tamper

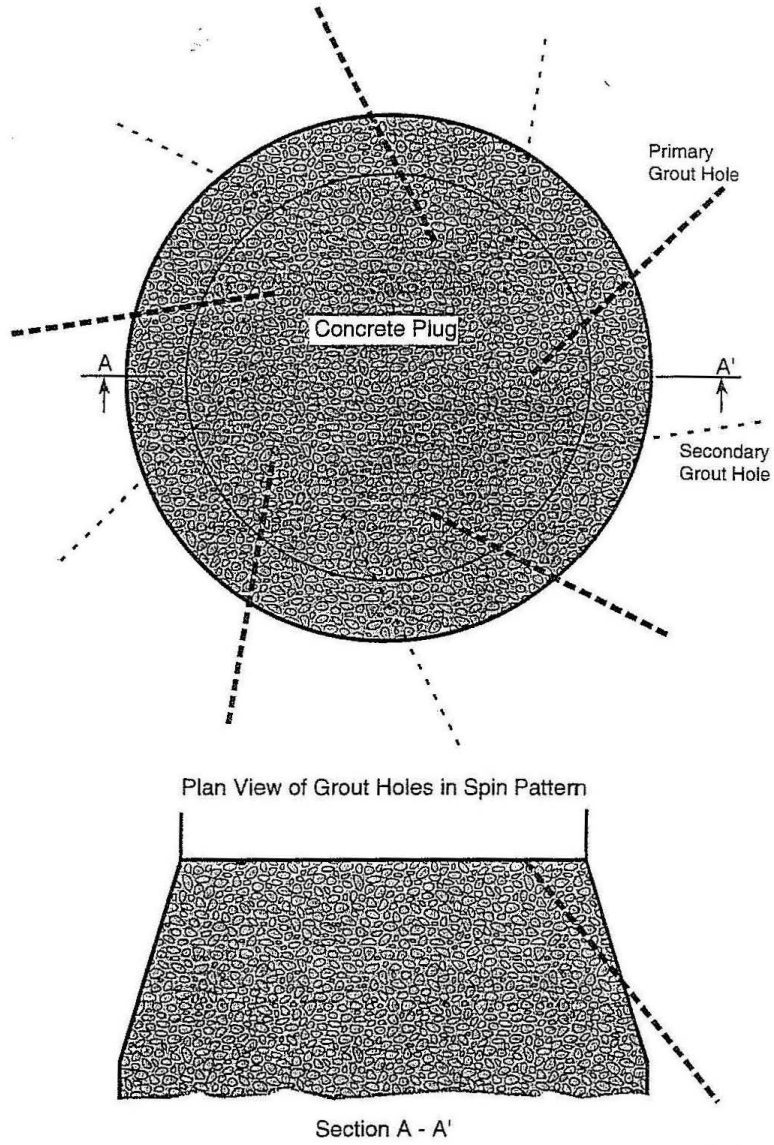

TRI-6121-373-0

Figure G2-9
Plan and Section Views of Downward Spin Pattern of Grout Holes

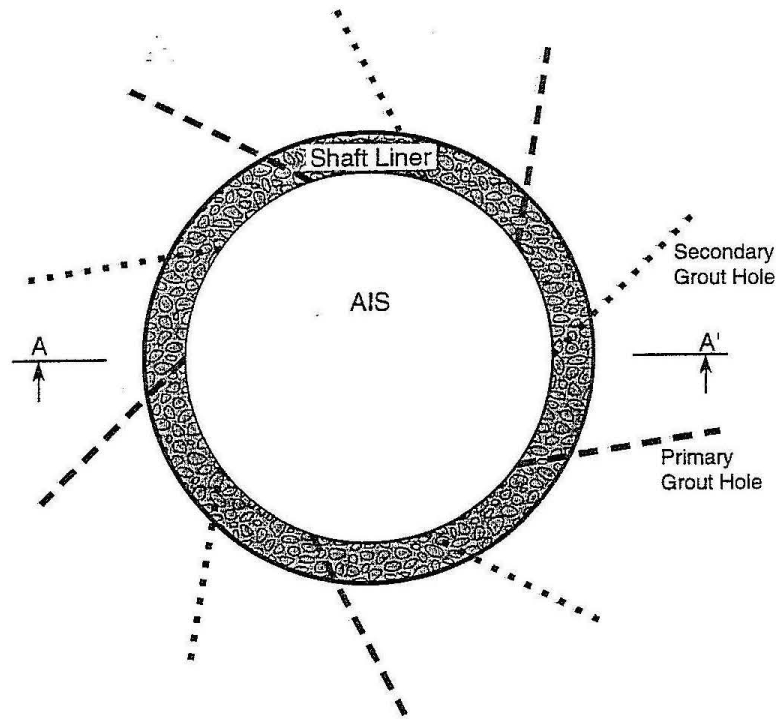

Plan View of Grout Holes in Spin Pattern



Section A - A'

TRI-6121-374-0

Figure G2-10
Plan and Section Views of Upward Spin Pattern of Grout Holes

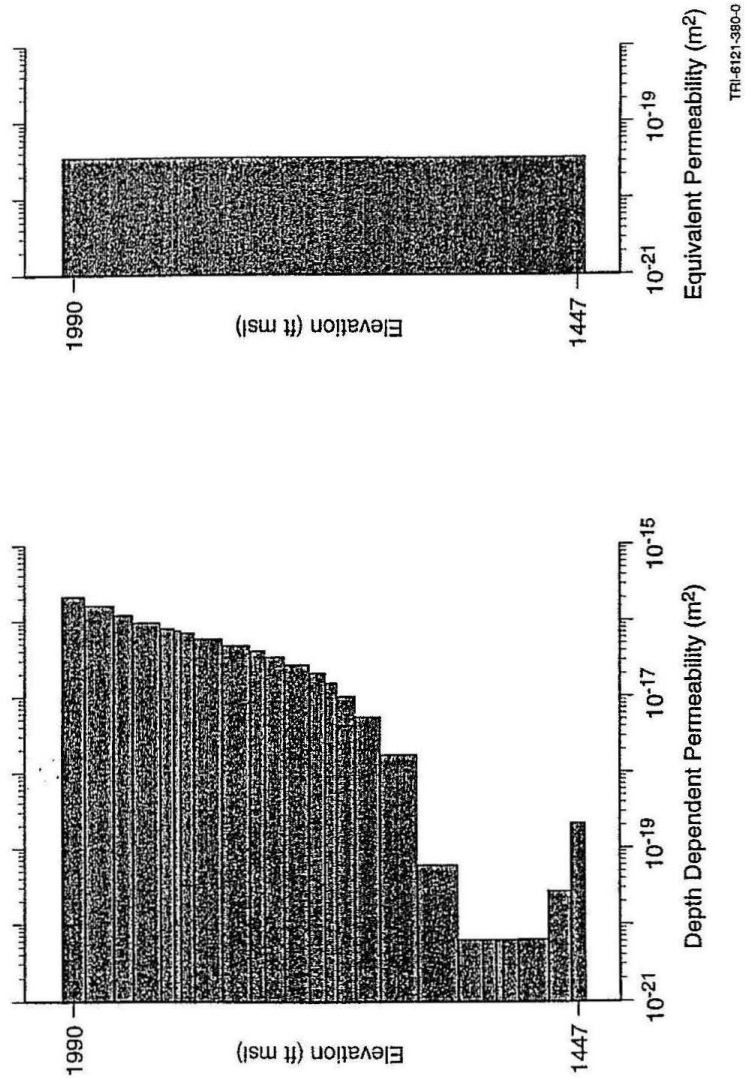

Figure G2-11
Example of Calculation of an Effective Salt Column Permeability from the Depth-
Dependent Permeability at a Point in Time

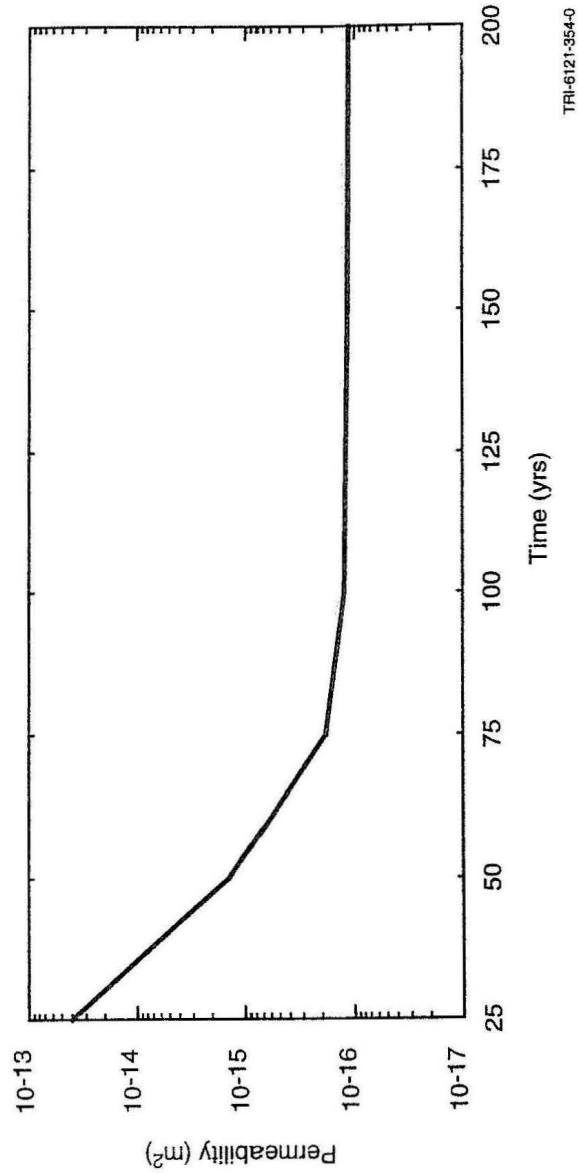

Figure G2-12
Effective Permeability of the Compacted Salt Column using the 95% Certainty Line

**ATTACHMENT G2
APPENDIX G2-A**

MATERIAL SPECIFICATION

**SHAFT SEALING SYSTEM
COMPLIANCE SUBMITTAL DESIGN REPORT**

**ATTACHMENT G2
APPENDIX G2-A**

MATERIAL SPECIFICATION

**SHAFT SEALING SYSTEM
COMPLIANCE SUBMITTAL DESIGN REPORT**

Appendix A Abstract

This appendix specifies material characteristics for shaft seal system components designed for the Waste Isolation Pilot Plant. The shaft seal system will not be constructed for decades; however, if it were to be constructed in the near term, materials specified here could be placed in the shaft and meet performance specifications. A material specification is necessary today to establish a frame of reference for design and analysis activities and to provide a basis for seal material parameters. This document was used by three integrated working groups: (1) the architect/engineer for development of construction methods and supporting infrastructure, (2) fluid flow and structural analysis personnel for evaluation of seal system adequacy, and (3) technical staff to develop probability distribution functions for use in performance assessment. The architect/engineers provide design drawings, construction methods and schedules as appendices to the final shaft seal system design report, called the *Compliance Submittal Design Report* (Permit Attachment G2). Similarly, analyses of structural aspects of the design and fluid flow calculations comprise other appendices to the final design report (not included in this Permit Attachment). These products together are produced to demonstrate the adequacy of the shaft seal system to independent reviewers, regulators, and stakeholders. It is recognized that actual placement of shaft seals is many years in the future, so design, planned construction method, and components will almost certainly change between now and the time that detailed construction specifications are prepared for the bidding process. Specifications provided here are likely to guide future work between now and the time of construction, perhaps benefiting from optimization studies, technological advancements, or experimental demonstrations.

TABLE OF CONTENTS

A1.	Introduction.....	5
A1.1	Sealing Strategy	7
A1.2	Longevity.....	7
A2.	Material Specifications	9
A2.1	Mass Concrete	9
A2.1.1	Functions	10
A2.1.2	Material Characteristics	10
A2.1.3	Construction.....	12
A2.1.4	Performance Requirements.....	13
A2.1.5	Verification Methods.....	14
	A2.1.5.1 Fine Aggregate.....	15
	A2.1.5.2 Coarse Aggregate	16
	A2.1.5.3 Batch-Plant Control	16
	A2.1.5.4 Concrete Products.....	16
A2.2	Compacted Clay	16
A2.2.1	Functions	16
A2.2.2	Material Characteristics	17
A2.2.3	Construction.....	18
A2.2.4	Performance Requirements.....	19
A2.2.5	Verification Methods.....	20
A2.3	Asphalt Components	20
A2.3.1	Functions	21
A2.3.2	Material Characteristics	21
A2.3.3	Construction.....	22
A2.3.4	Performance Requirements.....	23
A2.3.5	Verification Methods.....	24
A2.4	Compacted Salt Column.....	24
A2.4.1	Functions	25
A2.4.2	Material Characteristics	25
A2.4.3	Construction.....	26
A2.4.4	Performance Requirements.....	26
A2.4.5	Verification Methods.....	27
A2.5	Cementitious Grout	28
A2.5.1	Functions	28
A2.5.2	Material Characteristics	28
A2.5.3	Construction.....	29
A2.5.4	Performance Requirements.....	29
A2.5.5	Verification Methods.....	29
A2.6	Earthen Fill.....	30
A2.6.1	Functions	30
A2.6.2	Material Characteristics	30
A2.6.3	Construction.....	30
A2.6.4	Performance Requirements.....	30
A2.6.6	Verification	30

A3. Concluding Remarks.....30
 A4. References32

FIGURES

Figure	Title
Figure G2A-1	Schematic of the WIPP Shaft Seal Design
Figure G2A-2	Cumulative Distribution Function for SMC
Figure G2A-3	Sodium Bentonite Permeability Versus Density
Figure G2A-4	Cumulative Frequency Distribution for Compacted Bentonite
Figure G2A-5	Asphalt Permeability Cumulative Frequency Distribution Function
Figure G2A-6	Fractional Density of the Consolidating Salt Column
Figure G2A-7	Permeability of Consolidated Crushed Salt as a Function of Fractional Density
Figure G2A-8	Compacted Salt Column Permeability Cumulative Frequency Distribution Function at Seal Midpoint 100 Years Following Closure

TABLES

Table	Title
Table A-1	Concrete Mixture Proportions
Table A-2	Standard Specifications for Concrete Materials
Table A-3	Chemical Composition of Expansive Cement
Table A-4	Requirements for Salado Mass Concrete Aggregates
Table A-5	Target Properties for Salado Mass Concrete
Table A-6	Test Methods Used for Measuring Concrete Properties During and After Mixing
Table A-7	Test Methods Used for Measuring Properties of Hardened Concrete
Table A-8	Representative Bentonite Composition.
Table A-9	Asphalt Component Specifications
Table A-10	Ultrafine Grout Mix Specification

A1. INTRODUCTION

This appendix provides a body of technical information for each of the WIPP shaft seal system materials identified in the text of the *Compliance Submittal Design Report* (Permit Attachment G2). This material specification characterizes each seal material, establishes why it will function adequately, states briefly how each component will be placed, and quantifies expected characteristics, particularly permeability, pertinent to a WIPP-specific shaft seal design. Each material is first described from an engineering viewpoint, then appropriate properties are summarized in tables and figures which emphasize permeability parameter distribution functions used in performance calculations. Materials are discussed beyond limits normally found in conventional construction specifications. Descriptive elements focus on stringent shaft seal system requirements that are vital to regulatory compliance demonstration. Information normally contained in an engineering *performance specification* is included because more than one construction method, or even a completely different material, may function adequately. Content that would eventually be included contractually in *specifications for materials* or *specifications for workmanship* are not included in detail. The goal of these specifications is to substantiate why materials used in this seal system design will limit fluid flow and thereby adequately limit releases of hazardous constituents from the WIPP site at the point of compliance defined in Permit Part 5 and limit releases of radionuclides at the regulatory boundary.

Figure G2A-1 is a schematic drawing of the proposed WIPP shaft sealing system. Design detail and other characteristics of the geologic, hydrologic and chemical setting are provided in the main body of Permit Attachment G2, other appendices, and references. The four shafts will be entirely filled with dense materials possessing low permeability and other desirable engineering and economic attributes. Seal materials include concrete, clay, asphalt, and compacted salt. Other construction and fill materials include cementitious grout and earthen fill. The level of detail included for each material, and the emphasis of detail, vary among the materials. Concrete, clay, and asphalt are common construction materials used extensively in hydrologic applications. Their descriptions will be rather complete, and performance expectations will be drawn from the literature and site-specific references. Portland cement concrete is the most common structural material being proposed for the WIPP shaft seal system and its use has a long history. Considerable specific detail is provided for concrete because it is salt-saturated. Clay is used extensively in the seal system. Clay is often specified in industry as a construction material, and bentonitic clay has been widely specified as a low permeability liner for hazardous waste sites. Therefore, a considerable body of information is available for clay materials, particularly bentonite. Asphalt is a widely used paving and waterproofing material, so its specification here reflects industry practice. It has been used to seal shaft linings as a filler between the concrete and the surrounding rock, but has not been used as a full shaft seal component. Compaction and natural reconsolidation of crushed salt are uniquely applied here. Therefore, the crushed salt specification provides additional information on its constitutive behavior and sealing performance. Cementitious grout is also specified in some detail because it has been developed and tested for WIPP-specific applications and similar international waste programs. Earthen fill will be given only cursory specifications here because it has little impact on the shaft seal performance and placement to nominal standards is easily attained.

Discussion of each material is divided into sections, which are described in the annotated bullets below:

Functions

A general summary of functions of specific seal components is presented. Each seal component must function within a natural setting, so design considerations embrace naturally occurring characteristics of the surrounding rock.

Material Characteristics

Constitution of the seal material is described and key physical, chemical, mechanical, hydrological, and thermal features are discussed.

Construction

A brief mention is made regarding construction, which is more thoroughly treated in Appendix B of the *Compliance Submittal Design Report* (Permit Attachment G2, Appendix B). Construction, as discussed in this section, is primarily concerned with proper placement of materials. A viable construction procedure that will attain placement specifications is identified, but such a specification does not preclude other potential methods from use when the seal system is eventually constructed.

Performance Requirements

Regulations to which the WIPP must comply do not provide quantitative specifications applicable to seal design. Performance of the WIPP repository is judged against performance standards for miscellaneous units specified in 20.4.1.500 NMAC (incorporating 40 CFR §264.601) for releases of hazardous constituents at the point of compliance defined in Permit Part 5. Performance is also judged against potential releases of radionuclides at the regulatory boundary, which is a probabilistic calculation. To this end, probability distribution functions for permeabilities (referred to as PDFs) of each material have been derived for performance assessment of the WIPP system and are included within this subsection on performance requirements.

Verification Methods

It must be assured that seal materials placed in the shaft meet specifications. Both design and selection of materials reflect this principal concern. Assurance is provided by quality control procedures, quality assurance protocol, real-time testing, demonstrations of technology before construction, and personnel training. Materials and construction procedures are kept relatively simple, which creates robustness within the overall system. In addition, elements of the seal system often are extensive in length, and construction will require years to complete. If atypical placement of materials is detected, corrections can be implemented without impacting performance. These specifications limit in situ testing of seal material as it is constructed although, if it is later determined to be desirable, certain in situ tests can be amended in construction specifications. Invasive testing has the potential to compromise the material, add cost, and create logistic and safety problems. Conventional specifications are made for property testing and quality control.

References

These specifications draw on a wealth of information available for each material. Reference to literature values, existing data, anecdotal information, similar applications, laboratory and field testing, and other applicable supportive documentation is made.

A1.1 Sealing Strategy

The shaft seal system design is an integral part of compliance with 20.4.1.500 NMAC (incorporating 40 CFR §264) and 40 CFR §191. The EPA has also promulgated 40 CFR §194, entitled "Criteria for the Certification and Re-certification of the Waste Isolation Pilot Plant's Compliance with the 40 CFR Part 191," to which this design and these specifications are responsive. Other seal design requirements, such as State of New Mexico regulations, apply to stratigraphy above the Salado.

Compliance of the site with 20.4.1.500 NMAC (incorporating 40 CFR §264) and 40 CFR §191 will be determined in part by the ability of the seal system to limit migration of hazardous constituents to the point of compliance defined in Permit Part 5, and migration of radionuclides to the regulatory boundary. Both natural and engineered barriers may combine to form the isolation system, with the shaft seal system forming an engineered barrier in a natural setting. Seal system materials possess high durability and compatibility with the host rock. All materials used in the shaft seal system are expected to maintain their integrity for very long periods. The system contains functional redundancy and uses differing materials to reduce uncertainty in performance. Some sealing components are used to retard fluid flow soon after placement, while other components are designed to function well beyond the regulatory period. International programs engaged in research and demonstration of sealant technology provide significant information on longevity of materials similar to those proposed for this shaft seal system (Gray, 1993). When this information is applied to the setting and context of the WIPP, there is strong evidence that the materials specified will maintain their positive attributes for defensibly long periods.

A1.2 Longevity

Longevity of materials is considered within the site geologic and hydrologic setting as summarized in the main body of this report (Permit Attachment G2) and described in the Seal System Design Report (DOE, 1995). A major environmental advantage of the WIPP locality is an overall lack of groundwater to seal against. In terms of sealing the WIPP site, the stratigraphy can be conveniently divided into the Salado Formation and the superincumbent formations comprising primarily the Rustler Formation and the Dewey Lake Redbeds. The Salado Formation, composed mainly of evaporite sequences dominated by halite, is nearly impermeable. Transmissivity of engineering importance in the Salado Formation is lateral along anhydrite interbeds, basal clays, and fractured zones near underground openings. Neither the Dewey Lake Redbeds nor the Rustler Formation contains regionally productive sources of water, although seepage near the surface in the Exhaust Shaft has been observed. Permeability of materials placed in the Salado below the contact with the Rustler, and their effects on the surrounding disturbed rock zone, are the primary engineering properties of concern. Even though very little regional water is present in the geologic setting, the seal system reflects great concern for groundwater's potential influence on materials comprising the shaft seal system.

Shaft seal materials have been selected in part because of their exceptional durability. However, it is recognized that brine chemistry *could* impact engineered materials if conditions permitted. Highly concentrated saline solutions can, under severe circumstances, affect performance of cementitious materials and clay. Concrete has been shown to degrade under certain conditions, and clays can be more transmissive to brine than to potable water. Asphalt and compacted salt are essentially chemically inert to brine. Although stable in naturally occurring seeps such as those in the Santa Barbara Channel (California), asphalt can degrade when subjected to ultraviolet light or through microbial activity. Brine would not chemically change the compacted salt column, but mechanical effects of pore pressure are of concern to reconsolidation. Mechanical influences of brine on the reconsolidating salt column are discussed in Sections 7 and 8 of the main report (Permit Attachment G2), which summarize Appendices D and C, respectively (Appendices C and D are not included in the Permit, but are contained in *Waste Isolation Pilot Plant Shaft Sealing System Compliance Submittal Design Report* ("Compliance Submittal Design Report") (Sandia, 1996)).

Because of limited volumes of brine, low hydraulic gradients, and low permeability materials, the geochemical setting will have little influence on shaft seal materials. Each material is durable, though the potential exists for degradation or alteration under extreme conditions. For example, the three major components of portland cement concrete, portlandite ($\text{Ca}(\text{OH})_2$), calcium-aluminate-hydrate (CAH) and calcium-silicate-hydrate (CSH), are not thermodynamically compatible with WIPP brines. If large quantities of high ionic strength brine were available and transport of mass was possible, degradation of cementitious phases would certainly occur. Such a localized phenomenon was observed on a construction joint in the liner of the Waste Handling Shaft at the WIPP site. Within the shaft seal system, however, the hydrologic setting does not support such a scenario. Locally brine will undoubtedly contact the surface of mass placements of concrete. A low hydrologic gradient will limit mass transport, although degradation of paste constituents is expected where brine contacts concrete.

Among longevity concerns, degradation of concrete is the most recognized. At this stage of the design, it is established that only small volumes of brine ever reach the concrete elements (see Section 8). Further analysis concerned with borehole plugging using cementitious materials shows that at least 100 pore volumes of brine in an open system would be needed to begin degradation processes. In a closed system, such as the hydrologic setting in the WIPP shafts, phase transformations create a degradation product of increased volume. Net volume increase owing to phase transformation in the absence of mass transport would decrease rather than increase permeability of concrete seal elements.

Mechanical and chemical stability of clays, in this case the emphasis is on bentonitic clay, is particularly favorable in the WIPP geochemical and hydrological environment. A compendium of recent work associated with the Stripa project in Sweden (Gray, 1993) provides field-scale testing results, supportive laboratory experimental data, and thermodynamic modeling that lead to a conclusion that negligible transformation of the bentonite structure will occur over the regulatory period of the WIPP. In fact, very little brine penetration into clay components is expected, based on intermediate-scale experiments at WIPP. Any wetting of bentonite will result in development of swelling pressure, a favorable situation that would accelerate return to a uniform stress state within the clay component.

Natural bentonite is a stable material that generally will not change significantly over a period of ten thousand years. Bentonitic clays have been widely used in field and laboratory experiments concerned with radioactive waste disposal. As noted by Gray (1993), three internal

mechanisms, illitization, silicification and charge change, could affect sealing properties of bentonite. Illitization and silicification are thermally driven processes and, following discussion by Gray (1993), are not possible in the environment or time-frame of concern at the WIPP. The naturally occurring Wyoming bentonite which is the specified material for the WIPP shaft seal is well over a million years old. It is, therefore, highly unlikely that metamorphism of bentonite enters as a design concern.

Asphalt has existed for thousands of years as natural seeps. Longevity studies specific to DOE's Hanford site have utilized asphalt artifacts buried in ancient ceremonies to assess long-term stability (Wing and Gee, 1994). Asphalt used as a seal component deep in the shaft will inhabit a benign environment, devoid of ultraviolet light or an oxidizing atmosphere. Additional assurance against possible microbial degradation in asphalt elements is mitigated with addition of lime. For these reasons, it is thought that design characteristics of asphalt components will endure well beyond the regulatory period.

Materials being used to form the shaft seals are the same as those being suggested in the scientific and engineering literature as appropriate for sealing deep geologic repositories for radioactive wastes. This fact was noted during independent technical review. Durability or longevity of seal components is a primary concern for any long-term isolation system. Issues of possible degradation have been studied throughout the international community and within waste isolation programs in the USA. Specific degradation studies are not detailed in this document because longevity is one of the over-riding attributes of the materials selected and degradation is not perceived to be likely. However, it is acknowledged here that microbial degradation, seal material interaction, mineral transformation, such as silicification of bentonite, and effects of a thermal pulse from asphalt or hydrating concrete remain areas of continued study.

A2. MATERIAL SPECIFICATIONS

The WIPP shaft seal system plays an important role in meeting regulatory requirements such as 20.4.1.500 NMAC (incorporating 40 CFR §§264.111 and 264.601) and 40 CFR 191. A combination of available, durable materials which can be emplaced with low permeability is proposed as the seal system. Components include mass concrete, asphalt waterstops sandwiched between concrete plugs, a column of asphalt, long columns of compacted clay, and a column of compacted crushed WIPP salt. The design is based on common materials and construction technologies that could be implemented using today's technology. In choosing materials, emphasis was given to permeability characteristics and mechanical properties. The function, constitution, construction, performance, and verification of each material are given in the following sections.

A2.1 Mass Concrete

Concrete has exceptionally low permeability and is widely used for hydraulic applications such as water storage tanks, water and sewer systems, and massive dams. Salt-saturated concrete has been used successfully as a seal material in potash and salt mining applications. Upon hydration, unfractured concrete is nearly impermeable, having a permeability less than 10^{-20} m². In addition, concrete is a primary structural material used for compression members in countless applications. Use of concrete as a shaft seal component takes advantage of its many attributes and the extensive documentation of its use.

This specification for mass concrete will discuss a special design mixture of a salt-saturated concrete called Salado Mass Concrete or SMC (Wakeley et al., 1995). Performance of SMC and similar salt-saturated mixtures is established and will be completely adequate for concrete applications within the WIPP shafts. Because concrete is such a widely used material, it has been written into specifications many times. Therefore, the specification for SMC contains recognized standard practices, established test methods, quality controls, and other details that are not available at a similar level for other seal materials. Use of salt-saturated concrete, especially SMC, is backed by extensive laboratory and field studies that establish performance characteristics far exceeding requirements of the WIPP shaft seal system.

A2.1.1 Functions

The function of the concrete is to provide a durable component with small void volume, adequate structural compressive strength, and low permeability. Concrete components appear within the shaft seal system at the very bottom, the very top, and several locations in between where they provide a massive plug that fills the opening and a tight interface between the plug and host rock. In addition, concrete is a rigid material that will support overlying seal components while promoting natural healing processes within the salt disturbed rock zone (the DRZ is discussed further in Appendix D of the Compliance Submittal Design Report (Sandia, 1996)).

Concrete is one of the redundant components that protects the reconsolidating salt column. Since the salt column will achieve low permeabilities in fewer than 100 years (see Section 2.4.4 of this specification), concrete would no longer be needed after that time. For purposes of performance assessment calculations, a change in concrete permeability to degraded values is "allowed" to occur. However, concrete within the Salado Formation is likely to endure throughout the regulatory period with sustained engineering properties.

All concrete sealing elements, with the exception of a possible concrete cap, are unreinforced. In conventional civil engineering design, reinforcement is used to resist tensile stresses since concrete is weak in tension and reinforcement bar (rebar) balances tensile stresses in the steel with compressive stresses in concrete. However, concrete has exceptional compressive strength, and all the states of stress within the shaft will be dominated by compressive stress. Mass concrete, by definition, is related to any volume of concrete where heat of hydration is a design concern. SMC is tailored to minimize heat of hydration and overall differential temperature. An analysis of hydration heat distribution is included in Appendix D of the Compliance Submittal Design Report (Sandia, 1996). Boundary conditions are favorable for reducing any possible thermally induced tensile cracking during the hydration process.

A2.1.2 Material Characteristics

Salt-saturated concrete contains sufficient salt as an aggregate to saturate hydration water with respect to NaCl. Salt-saturated concrete is required for all uses within the Salado Formation because fresh water concrete would dissolve part of the host rock. Dissolution would cause a poor bond and perhaps a more porous interface, at least initially.

Dry materials for SMC include cementitious materials, fine and coarse aggregates, and sodium chloride. Concrete mixture proportions of materials for one cubic yard of concrete appear in Table A-1.

**Table A-1
 Concrete Mixture Proportions**

Material	lb/yd ³
Portland cement	278
Class F fly ash	207
Expansive cement	134
Fine aggregate	1292
Coarse aggregate	1592
Sodium chloride	88
Water	225

kg/m³ = (lb/yd³) * (0.59). Water: Cement Ratio is weight of water divided by all cementitious materials.

Table A-2 is a summary of standard specifications for concrete materials. Further discussion of each specification is presented in subsequent text, where additional specifications pertinent to particular concrete components are also given.

**Table A-2
 Standard Specifications for Concrete Materials**

Material	Applicable Standard Tests and Specifications	Comments
Class H oilwell cement	American Petroleum Institute Specification 10	Chemical composition determined according to ASTM C 114
Class F fly ash	ASTM C 618, Standard Specification for Fly Ash	Composition and properties determined according to ASTM C 311
Expansive cement	Similar to ASTM C 845	Composition determined according to ASTM C 114
Salt	ASTM E 534, Chemical Analysis of Sodium Chloride	Batched as dry ingredient, not as an admixture
Coarse and fine aggregates	ASTM C 33, Standard Specification for Concrete Aggregates; ASTM C 294 and C 295 also applied	Moisture content determined by ASTM C 566

Portland cement shall conform to American Petroleum Institute (API) Specification 10 Class G or Class H. Additional requirements for the cement are that the fineness as determined according to ASTM C 204 shall not exceed 300 m²/kg, and the cement must meet the requirement in ASTM C 150 for moderate heat of hydration.

Fly Ash shall conform to ASTM C 618, Class F, with the additional requirement that the percentage of Ca cannot exceed 10 %.

Expansive cement for shrinkage-compensation shall have properties so that, when used with portland cement, the resulting blend is shrinkage compensating by the mechanism described in ASTM C 845 for Type K cement. Additional requirements for chemical composition of the shrinkage compensating cement appear in Table A-3.

**Table A-3
 Chemical Composition of Expansive Cement**

Chemical composition	Weight %
Magnesium oxide, max	1.0
Calcium oxide, min	38.0
Sulfur trioxide, max	28.0
Aluminum trioxide (AL ₂ O ₃), min	7.0
Silicon dioxide, min	7.0
Insoluble residue, max	1.0
Loss on ignition, max	12.0

Sodium Chloride shall be of a technical grade consisting of a minimum of 99.0 % sodium chloride as determined according to ASTM E 534, and shall have a maximum particle size of 600 µm.

Aggregate proportions are reported here on saturated surface-dry basis. Specific gravity of coarse and fine aggregates used in these proportions were 2.55 and 2.58, respectively. Absorptions used in calculations were 2.25 (coarse) and 0.63 (fine) % by mass. Concrete mixture proportions will be adjusted to accommodate variations in the materials selected, especially differences in specific gravity and absorptions of aggregates. Fine aggregate shall consist of natural silica sand. Coarse aggregate shall consist of gravel. The quantity of flat and elongated particles in the separate size groups of coarse aggregates, as determined by ASTM D 4791, using a value of 3 for width-thickness ratio and length-width ratio, shall not exceed 25 % in any size group. Moisture in the fine and coarse aggregate shall not exceed 0.1 % when determined in accordance with ASTM C 566. Aggregates shall meet the requirements listed in Table A-4.

A2.1.3 Construction

Construction techniques include surface preparation of mass concrete and slickline (a drop pipe from the surface) placement at depth within the shaft. A batching and mixing operation on the surface will produce a wet mixture having initial temperatures not exceeding 20°C. Placement uses a tremie line, where the fresh concrete exits the slickline below the surface level of the concrete being placed. This procedure will minimize entrained air. Placement requires no vibration and, except for the large concrete monolith at the base of each shaft, no form work. No special curing is required for the concrete because its natural environment ensures retention of humidity and excellent hydration conditions. It is desired that each concrete pour be continuous, with the complete volume of each component placed without construction joints. However, no perceivable reduction in performance is anticipated if, for any reason, concrete placement is interrupted. A free face or cold joint could allow lateral flow but would remain perpendicular to flow down the shaft. Further discussion of concrete construction is presented in Permit Attachment G2, Appendix B.

Table A-4
Requirements for Salado Mass Concrete Aggregates

Property	Fine Aggregate	Coarse Aggregate
Specific Gravity (ASTM C 127, ASTM C 128)	2.65, max	2.80, max
Absorption (ASTM C 127, ASTM C 128)	1.5 percent, max	3.5 percent, max
Clay Lumps and Friable Particles (ASTM C 142)	3.0 percent, max	3.0 percent, max
Material Finer than 75- μ m (No. 200) Sieve (ASTM C 117)	3.0 percent, max	1.0 percent, max
Organic Impurities (ASTM C 40)	No. 3, max	N/A
L.A. Abrasion (ASTM C 131, ASTM C 535)	N/A	50 percent, max
Petrographic Examination (ASTM C 295)	Carbonate mineral aggregates shall not be used	Carbonate rock aggregates shall not be used
Coal and Lignite, less than 2.00 specific gravity (ASTM C 123)	0.5 percent, max	0.5 percent, max

A2.1.4 Performance Requirements

Specifications of concrete properties include characteristics in the green state as well as the hardened state. Properties of hydrated concrete include conventional mechanical properties and projections of permeabilities over hundreds of years, a topic discussed at the end of this section. Table A-5 summarizes target properties for SMC. Attainment of these characteristics has been demonstrated (Wakeley et al., 1995). SMC has a strength of about 40 MPa at 28 days and continues to gain strength after that time, as is typical of hydrating cementitious materials. Concrete strength is naturally much greater than required for shaft seal elements because the state of stress within the shafts is compressional with little shear stress developing. In addition, compressive strength of SMC increases as confining pressure increases (Pfeifle et al., 1996). Volume stability of the SMC is also excellent, which assures a good bond with the salt.

Thermal and constitutive models for the SMC are described in Appendix D of the Compliance Submittal Design Report (Sandia, 1996). Thermal properties are fit to laboratory data and used to calculate heat distribution during hydration. An isothermal creep law and an increasing modulus are used to represent the concrete in structural calculations. The resistance established by concrete to inward creep of the Salado Formation accelerates healing of microcracks in the salt. The state of stress impinging on concrete elements within the Salado Formation will approach a lithostatic condition.

**Table A-5
Target Properties for Salado Mass Concrete**

Property	Comment
Initial slump 10 ± 1.0 in. Slump at 2 hr 8 ± 1.5 in.	ASTM C 143, high slump needed for pumping and placement
Initial temperature ≤ 20°C	ASTM C 1064, using ice as part of mixing water
Air content ≤ 2.0%	ASTM C 231 (Type B meter), tight microstructure and higher strength
Self-leveling	Restrictions on underground placement may preclude vibration
No separately batched admixtures	Simple and reproducible operations
Adiabatic temperature rise ≤ 16°C at 28 days	To reduce thermally induced cracking
30 MPa (4500 psi) compressive strength	ASTM C 39, at 180 days after placement
Volume stability	ASTM C 157, length change between +0.05 and -0.02% through 180 days

Permeability of SMC is very low, consistent with most concretes. Owing to a favorable state of stress and isothermal conditions, the SMC will remain intact. Because little brine is available to alter concrete elements, minimal degradation is possible. Resistance to phase changes of salt-saturated concretes and mortars within the WIPP setting has been excellent. These favorable attributes combine to assure concrete elements within the Salado will remain structurally sound and possess very low permeability for exceedingly long periods.

Permeabilities of SMC and other salt-saturated concretes have been measured in Small-Scale Seal Performance Tests (SSSPT) and Plug Test Matrix (PTM) at the WIPP for a decade and are corroborated by laboratory measurements (e.g., Knowles and Howard, 1996; Pfeifle et al., 1996). From these tests, values and ranges of concrete permeability have been developed. For performance assessments calculations, permeability of SMC seal components is treated as a random variable defined by a log triangular distribution with a best estimator of $1.78 \times 10^{-19} \text{ m}^2$ and lower and upper limits of 2.0×10^{-21} and $1.0 \times 10^{-17} \text{ m}^2$, respectively.

The probability distribution function is shown in Figure G2A-2. Further, it is recognized that concrete function is required for only a relatively short-term period as salt reconsolidates. Concrete is expected to function adequately beyond its design life. For calculational expediency, a higher, very conservative permeability of 1.0×10^{-14} is assigned to concrete after 400 years. This abrupt change in permeability does not imply degradation, but rather reflects system redundancy and the fact that concrete is no longer relied on as a seal component.

A2.1.5 Verification Methods

The concrete supplier shall perform the inspection and tests described below (Tables A-6 and A-7) and, based on the results of these inspections and tests, shall take appropriate action. The laboratory performing verification tests shall be on-site and shall conform with ASTM C 1077. Individuals who sample and test concrete or the constituents of concrete as required in this specification shall have demonstrated a knowledge and ability to perform the necessary test procedures equivalent to the ACI minimum guidelines for certification of Concrete Laboratory Testing Technicians, Grade I. The Buyer will inspect the laboratory, equipment, and test

procedures for conformance with ASTM C 1077 prior to start of dry materials batching operations and prior to restarting operations.

A2.1.5.1 Fine Aggregate

(A) *Grading*. Dry materials will be sampled while the batch plant is operating; there shall be a sieve analysis and fineness modulus determination in accordance with ASTM C 136.

(B) *Fineness Modulus Control Chart*. Results for fineness modulus shall be grouped in sets of three consecutive tests, and the average and range of each group shall be plotted on a control chart. The upper and lower control limits for average shall be drawn 0.10 units above and below the target fineness modulus, and the upper control limit for range shall be 0.20 units above the target fineness modulus.

**Table A-6
 Test Methods Used for Measuring Concrete Properties During and After Mixing**

Property	Test Method	Title
Slump	ASTM C 143	Slump of Portland Cement Concrete
Unit weight	ASTM C 138	Unit Weight, Yield, and Air Content (Gravimetric) of Concrete
Air content	ASTM C 231	Air Content of Freshly Mixed Concrete by the Pressure Method
Mixture temperature	ASTM C 1064	Temperature of Freshly Mixed Concrete

**Table A-7
 Test Methods Used for Measuring Properties of Hardened Concrete**

Property	Test Method	Title
Compressive strength	ASTM C 39	Compressive Strength of Cylindrical Concrete Specimens
Modulus of elasticity	ASTM C 469	Static Modulus of Elasticity and Poisson's Ratio of Concrete in Compression
Volume stability	ASTM C 157	Length Change of Hardened Cement Mortar and Concrete

(C) *Corrective Action for Fine Aggregate Grading*. When the amount passing any sieve is outside the specification limits, the fine aggregate shall be immediately resampled and retested. If there is another failure for any sieve, the fact shall be immediately reported to the Buyer. Whenever a point on the fineness modulus control chart, either for average or range, is beyond one of the control limits, the frequency of testing shall be doubled. If two consecutive points are beyond the control limits, the process shall be stopped and stock discarded if necessary.

(D) *Moisture Content Testing*. There shall be at least two tests for moisture content in accordance with ASTM C 566 during each 8-hour period of dry materials batch plant operation.

(E) *Moisture Content Corrective Action*. Whenever the moisture content of fine aggregate exceeds 0.1 % by weight, the fine aggregate shall be immediately resampled and retested. If there is another failure the batching shall be stopped.

A2.1.5.2 Coarse Aggregate

(A) *Grading.* Coarse aggregate shall be analyzed in accordance with ASTM C 136.

(B) *Corrective Action for Grading.* When the amount passing any sieve is outside the specification limits, the coarse aggregate shall be immediately resampled and retested. If the second sample fails on any sieve, that fact shall be reported to the Buyer. Where two consecutive averages of five tests are outside specification limits, the dry materials batch plant operation shall be stopped, and immediate steps shall be taken to correct the grading.

(C) *Moisture Content Testing.* There shall be at least two tests for moisture content in accordance with ASTM C 566 during each 8-hour period of dry materials batch plant operation.

(D) *Moisture Content Corrective Action.* Whenever the moisture content of coarse aggregate exceed 0.1 % by weight, the coarse aggregate shall be immediately resampled and retested. If there is another failure, batching shall be stopped.

A2.1.5.3 Batch-Plant Control

The measurement of all constituent materials including cementitious materials, each size of aggregate, and granular sodium chloride shall be continuously controlled. The aggregate batch weights shall be adjusted as necessary to compensate for their nonsaturated surface-dry condition.

A2.1.5.4 Concrete Products

Concrete products will be tested during preparation and after curing as summarized in Tables A-6 and A-7 for preparation and hydrated concrete, respectively.

A2.2 Compacted Clay

Compacted clays are commonly proposed as primary sealing materials for nuclear waste repositories and have been extensively investigated (e.g., Gray, 1993). Compacted clay as a shaft sealing component provides a barrier to brine and possibly to gas flow into or out of the repository and supports the shaft with a high density material to minimize subsidence. In the event that brine does contact the compacted clay columns, bentonitic clay can generate a beneficial swelling pressure. Swelling would increase internal supporting pressure on the shaft wall and accelerate healing of any disturbed rock zone. Wetted, swelling clay will seal fractures as it expands into available space and will ensure tightness between the clay seal component and the shaft walls.

A2.2.1 Functions

In general, clay is used to prevent fluid flow either down or up the shaft. In addition, clay will stabilize the shaft opening and provide a backstress within the Salado Formation that will enhance healing of microfractures in the disturbed rock. Bentonitic clays are specified for Components 4, 8, and 12. In addition to limiting brine migration down the shafts, a primary function of a compacted clay seal through the Rustler Formation (Component 4) is to provide separation of water bearing units. The primary function of the upper Salado clay column (Component 8) is to limit groundwater flow down the shaft, thereby adding assurance that the

reconsolidating salt column is protected. The lower Salado compacted clay column (Component 12) will act as a barrier to brine and possibly to gas flow (see construction alternatives in Appendix B) soon after placement and remain a barrier throughout the regulatory period.

A2.2.2 Material Characteristics

The Rustler and Salado compacted clay columns will be constructed of a commercial well-sealing grade sodium bentonite blocks compacted to between 1.8 and 2.0 g/cm³. An extensive experimental data base exists for the permeability of sodium bentonites under a variety of conditions. Many other properties of sodium bentonite, such as strength, stiffness, and chemical stability also have been thoroughly investigated. Advantages of clays for sealing purposes include low permeability, demonstrated longevity in many types of natural environments, deformability, sorptive capacity, and demonstrated successful utilization in practice for a variety of sealing purposes.

A variety of clays could be considered for WIPP sealing purposes. For WIPP, as for most if not all nuclear waste repository projects, bentonite has been and continues to be a prime candidate as the clay sealing material. Bentonite clay is chosen here because of its overwhelming positive sealing characteristics. Bentonite is a highly plastic swelling clay material (e.g., Mitchell, 1993), consisting predominantly of smectite minerals (e.g., IAEA, 1990). Montmorillonite, the predominant smectite mineral in most bentonites, has the typical plate-like structure characteristic of most clay minerals.

The composition of a typical commercially available sodium bentonite (e.g. Volclay, granular sodium bentonite) contains over 90% montmorillonite and small portions of feldspar, biotite, selenite, etc. A typical sodium bentonite has the chemical composition summarized in Table A-8 (American Colloid Company, 1995). This chemical composition is close to that reported for MX-80 which was used successfully in the Stripa experiments (Gray, 1993). Sodium bentonite has a tri-layer expanding mineral structure of approximately $(Al Fe_{1.67} Mg_{0.33}) Si_4O_{10} (OH)_2 Na^+Ca^{++0.33}$. Specific gravity of the sodium bentonite is about 2.5. The dry bulk density of granular bentonite is about 1.04 g/cm³.

Densely compacted bentonite (of the order of 1.75 g/cm³), when confined, can generate a swelling pressure up to 20 MPa when permeated by water (IAEA, 1990). The magnitude of the swelling pressure generated depends on the chemistry of the permeating water. Laboratory and field measurements suggest that the bentonite specified for shaft seal materials in the Salado may achieve swell pressures of 3 to 4 MPa, and likely substantially less. Swelling pressure in the bentonite column is not expected to be appreciable because little contact with brine fluids is conceivable. Further considerations of potential swelling of bentonite within the Rustler Formation may be appropriate, however.

**Table A-8
 Representative Bentonite Composition.**

Chemical Compound	Weight %
SiO ₂	63.0
Al ₂ O ₃	21.1
Fe ₂ O ₃	3.0
FeO	0.4
MgO	2.7
Na ₂ O	2.6
CaO	0.7
H ₂ O	5.6
Trace Elements	0.7

Mixtures of bentonite and water can range in rheological characteristics from a virtually Newtonian fluid to a stiff solid, depending on water content. Bentonite can form stiff seals at low moisture content, and can penetrate fractures and cracks when it has a higher water content. Under the latter conditions it can fill void space in the seal itself and disturbed rock zones. Bentonite with dry density of 1.75 g/cm³ has a cohesion of 5-50 kPa, and a friction angle of 5 to 15° (IAEA, 1990). At density greater than 1.6-1.7 g/cm³, swelling pressure of bentonite is less affected by the salinity of groundwater providing better chemical and physical stabilities.

A2.2.3 Construction

Seal performance within the Salado Formation is far more important to regulatory compliance than is performance of earthen fill in the overlying formations. Three potential construction methods might be used to place clay in the shaft, as discussed in Appendix B. Construction of bentonite clay components specifies block assembly procedures demonstrated successfully at the WIPP site (Knowles and Howard, 1996) and in a considerable body of work by Roland Pusch (see summary in Gray, 1993). To achieve low permeabilities, dry density of the bentonite blocks should be about 2.0 g/cm³, although a range of densities is discussed in Section 2.2.4. A high density of clay components is also desirable to carry the weight of overlying seal material effectively and to minimize subsidence.

Placement of clay in the shaft is one area of construction that might be made more cost and time effective through optimization studies. An option to construct clay columns using dynamic compaction will likely prove to be efficient, so it is specified for earthen fill in the Dewey Lake Redbeds (as discussed later) and may prove to be an acceptable placement method for other components. Dynamic compaction would use equipment developed for placement of crushed salt. The Canadian nuclear waste program has conducted extensive testing, both in situ and in large scale laboratory compaction of clay-based barrier materials with dynamic hydraulically powered impact hammers (e.g., Kjartanson et al, 1992). The Swedish program similarly has investigated field compaction of bentonite-based tunnel backfill by means of plate vibrators (e.g., Nilsson, 1985). Both studies demonstrated the feasibility of in situ compaction of bentonite-based materials to a high density. Near surface, conventional compaction methods

will be used because insufficient space remains for dynamic compaction using the multi-deck work stage.

A2.2.4 Performance Requirements

The proven characteristics of bentonite assure attainment of very low permeability seals. It is recognized that the local environment contributes to the behavior of compacted clay components. Long-term material stability is a highly desired sealing attribute. Clay components located in brine environments will have to resist cation exchange and material structure alteration. Clay is geochemically mature, reducing likelihood of alteration and imbibition of brine is limited to isolated areas. Compacted clay is designed to withstand possible pressure gradients and to resist erosion and channeling that could conceivably lead to groundwater flow through the seal. Compacted clay seal components support the shaft walls and promote healing of the salt DRZ. Volume expansion or swelling would accelerate healing in the salt. A barrier to gas flow could be constructed if moisture content of approximately 85% of saturation could be achieved.

Permeability of bentonite is inversely correlated to dry density. Figure G2A-3 plots bentonite permeability as a function of reported sample density for sodium bentonite samples. The permeability ranges from approximately 1×10^{-21} to 1×10^{-17} m². In all cases, the data in Figure G2A-3 are representative of low ionic strength permeant waters. Data provided in this figure are limited to sodium bentonite and bentonite/sand mixtures with clay content greater than or equal to 50 %. Cheung et al. (1987) report that in bentonite/sand mixtures, sand acts as an inert fraction which does not alter the permeability of the mixture from that of a 100 % bentonite sample at the same equivalent dry density. Also included in Figure G2A-3 are the three point estimates of permeability at dry densities of 1.4, 1.8, and 2.1 g/cm³ provided by Jaak Daemen of the University of Nevada, Reno, who is actively engaged in WIPP-specific bentonite testing.

A series of in situ tests (SSSPTs) that evaluated compacted bentonite as a sealing material at the WIPP site corroborate data shown in Figure G2A-3. Test Series D tested two 100 % bentonite seals in vertical boreholes within the Salado Formation at the repository horizon. The diameter of each seal was 0.91 m, and the length of each seal was 0.91 m. Cores of the two bentonite seals had initial dry densities of 1.8 and 2.0 g/cm³. Pressure differentials of 0.72 and 0.32 MPa were maintained across the bentonite seals with a brine reservoir on the upstream (bottom) of the seals for several years.

Over the course of the seal test, no visible brine was observed at the downstream end of the seals. Upon decommissioning the SSSPT, brine penetration was found to be only 15 cm. Determination of the absolute permeability of the bentonite seal was not precise; however, a bounding calculation of 1×10^{-19} m² was made by Knowles and Howard (1996).

Beginning with a specified dry density of 1.8 to 2.0 g/cm³ and Figure G2A-3, a distribution function for clay permeability was developed and is provided in Figure G2A-4. Parameter distribution reflects some conservative assumptions pertaining to WIPP seal applications. The following provide rationale behind the distribution presented in Figure G2A-4.

1. A practical minimum for the distribution can be specified at 1×10^{-21} m².

2. If effective dry density of the bentonite emplaced in the seals only varies from 1.8 to 2.0 g/cm³, then a maximum expected permeability can be extrapolated from Figure G2A-3 as 1×10^{-19} m².
3. Uncertainty exists in being able to place massive columns of bentonite to design specifications. To address this uncertainty in a conservative manner, it is assumed that the compacted clay be placed at a dry density as low as 1.6 g/cm³. At 1.6 g/cm³, the maximum permeability for the clay would be approximately 5×10^{-19} m². Therefore, neglecting salinity effects, a range of permeability from 1×10^{-21} to 5×10^{-19} m² with a best estimate of less than 1×10^{-19} m² could be reasonably defined (assuming a best estimate emplacement density of 1.8 g/cm³). It could be argued, based on Figure G2A-3, that a best estimate could be as low as 2×10^{-20} m².

Salinity increases bentonite permeability; however, these effects are greatly reduced at the densities specified for the shaft seal. At seawater salinity, Pusch et al. (1989) report the effects on permeability could be as much as a factor of 5 (one-half order of magnitude). To account for salinity effects in a conservative manner, the maximum permeability is increased from 5×10^{-19} to 5×10^{-18} m². The best estimate permeability is increased by one-half order of magnitude to 5×10^{-19} m². The lower limit is held at 1×10^{-21} m². Because salinity effects are greatest at lower densities, the maximum is adjusted one full order of magnitude while the best estimate (assumed to reside at a density of 1.8 g/cm³) is adjusted one-half of an order.

The four arguments presented above give rise to the permeability cumulative frequency distribution plotted in Figure G2A-4, which summarizes the performance specification for bentonite columns.

A2.2.5 Verification Methods

Verification of specified properties such as density, moisture content or strength of compacted clay seals can be determined by direct access during construction. However, indirect methods are preferred because certain measurements, such as permeability, are likely to be time consuming and invasive. Methods used to verify the quality of emplaced seals will include quality of block production and field measurements of density. As a minimum, standard quality control procedures recommended for compaction operations will be implemented including visual observation, in situ density measurements, and moisture content measurements. Visual observation accompanied by detailed record keeping will assure design procedures are being followed. In situ testing will confirm design objectives are accomplished in the field.

Density measurements of compacted clay shall follow standard procedures such as ASTM D 1556, D 2167, and D 2922. The moisture content of clay blocks shall be calculated based on the water added during mixing and can be confirmed by following ASTM Standard procedures D 2216 and D 3017. It is probable that verification procedures will require modifications to be applicable within the shaft. As a minimum, laboratory testing to certify the above referenced quality control measures will be performed to assure that the field measurements provide reliable results.

A2.3 Asphalt Components

Asphalt is used to prevent water migration down the shaft in two ways: an asphalt column bridging the Rustler/Salado contact and a "waterstop" sandwiched between concrete plugs at

three locations within the Salado Formation, two above the salt column and one below the salt column. An asphalt mastic mix (AMM) that contains aggregate is specified for the column while the specification for the waterstop layer is pure asphalt.

Asphalt is a widely used construction material with many desirable properties. Asphalt is a strong cement, is readily adhesive, highly waterproof, and durable. Furthermore, it is a plastic substance that provides controlled flexibility to mixtures of mineral aggregates with which it is usually combined. It is highly resistant to most acids, salts, and alkalis. A number of asphalts and asphalt mixes are available that cover a wide range of viscoelastic properties which allows the properties of the mixture to be designed for a wide range of requirements for each application. These properties are well suited to the requirements of the WIPP shaft seal system.

A2.3.1 Functions

The generic purpose of asphalt seal components above the salt column is to eliminate water migration downward. The asphalt waterstops above the salt column are designed to intersect the DRZ and limit fluid flow. Asphalt is not the lone component preventing flow of brine downward; it functions in tandem with concrete and a compacted clay column. Waterstop Component # 11 located below the salt column would naturally limit upward flow of brine or gas. Concrete abutting the asphalt waterstops provides a rigid element that creates a backstress upon the inward creeping salt, promoting healing within the DRZ. Asphalt is included in the WIPP shaft seal system to reduce uncertainty of system performance by providing redundancy of function while using an alternative material type. The combination of shaft seal components restricts fluid flow up or down to allow time for the salt column to reconsolidate and form a natural fluid-tight seal.

The physical and thermal attributes of asphalt combine to reduce fluid flow processes. The placement fluidity permits asphalt to flow into uneven interstices or fractures along the shaft wall. Asphalt will self-level into a nearly voidless mass. As it cools, the asphalt will eventually cease flowing. The elevated temperature and thermal mass of the asphalt will enhance creep deformation of the salt and promote healing of the DRZ surrounding the shaft. Asphalt adheres tightly to most materials, eliminating flow along the interface between the seal material and the surrounding rock.

A2.3.2 Material Characteristics

The asphalt column specified for the WIPP seal system is an AMM commonly used for hydraulic structures. The AMM is a mixture of asphalt, sand, and hydrated lime. The asphalt content of AMM is higher than those used in typical hot mix asphalt concrete (pavements). High asphalt contents (10-20% by weight) and fine, well-graded aggregate (sand and mineral fillers) are used to obtain a near voidless mix. A low void content ensures a material with extremely low water permeability because there are a minimum number of connected pathways for brine migration.

A number of different asphaltic construction materials, including hot mix asphalt concrete (HMAC), neat asphalt, and AMMs, were evaluated for use in the WIPP seal design. HMAC was eliminated because of construction difficulty that might have led to questionable performance. An AMM is selected as a preferred alternative for the asphalt columns because it has economic and performance advantages over the other asphaltic options. Aggregate and mineral fines in the AMM increase rigidity and strength of the asphalt seal component, thereby enhancing the potential to heal the DRZ and reducing shrinkage relative to neat asphalt.

Viscosity of the AMM is an important physical property affecting construction and performance. The AMM is designed to have low enough viscosity to be pumpable at application temperatures and able to flow readily into voids. High viscosity of the AMM at operating temperatures prevents long-term flow, although none is expected. Hydrated lime is included in the mix design to increase the stability of the material, decrease moisture susceptibility, and act as an anti-microbial agent. Table A-9 details the mix design specifications for the AMM.

The asphalt used in the waterstop is AR-4000, a graded asphalt of intermediate viscosity. The waterstop uses pure, or neat, asphalt because it is a relatively small volume when compared to the column.

A2.3.3 Construction

Construction of asphalt seal components can be accomplished using a slickline process where the molten material is effectively pumped into the shaft. The AMM will be mixed at ground level in a pug mill at approximately 180°C. At this temperature the material is readily pourable. The AMM will be slicklined and placed using a heated and insulated tremie line. The AMM will easily flow into irregularities in the surface of the shaft or open fractures until the AMM cools. After cooling, flow into surface irregularities in the shaft and DRZ will slow considerably because of the sand and mineral filler components in the AMM and the temperature dependence of the viscosity of the asphalt. AMM requires no compaction in construction. Neat asphalt will be placed in a similar fashion.

The technology to pump AMM is available as described in the construction procedures in Appendix B. One potential problem with this method of construction is ensuring that the slickline remains heated throughout the construction phase. Impedance heating (a current construction technique) can be used to ensure the pipe remains at temperatures sufficient to promote flow. The lower section (say 10 m) of the pipe may not need to be heated, and it may not be desirable to heat it as it is routinely immersed in the molten asphalt during construction to minimize air entrainment. Construction using large volumes of hot asphalt would be facilitated by placement in sections. After several meters of asphalt are placed, the slickline would be retracted by two lengths of pipe and pumping resumed. Once installed, the asphalt components will cool; the column will require several months to approach ambient conditions. Calculations of cooling times and plots of isotherms for the asphalt column are given in Appendix D of the Compliance Submittal Design Report (Sandia, 1996). It should be noted that a thermal pulse into the surrounding rock salt could produce positive rock mechanics conditions. Fractures will heal much faster owing to thermally activated dislocation motion and diffusion. Salt itself will creep inward at a much greater rate as well.

**Table A-9
 Asphalt Component Specifications**

AMM Composition:		20 wt% asphalt (AR-4000 graded asphalt) 70 wt% aggregate (silicate sand) 10 wt% hydrated lime
Aggregate (% passing by weight)		
US Sieve Size		Specification Limits
2.36 mm	(No. 8)	100
1.18 mm	(No. 16)	90
600	(No. 30)	55-75
300	(No. 50)	35-50
150	(No. 100)	15-30
75	(No. 200)	5-15
Mineral Filler: Hydrated Lime Chemical Composition:		
Total active lime content (% by weight)		min. 90.0%
Unhydrated lime weight (% by weight CaO)		max. 5.0%
Free water (% by weight H ₂ O)		max. 4.0%
Residue Analysis:		
Residue retained on No. 6 sieve		max. 0.1%
Residue retained on No. 30 sieve		max. 3.0%

A2.3.4 Performance Requirements

Asphalt components are required to endure for about 100 years as an interim seal while the compacted salt component reconsolidates to create a very low permeability seal component. Since asphalt will not be subjected to ultraviolet light or an oxidizing environment, it is expected to provide an effective brine seal for several centuries. Air voids should be less than 2% to ensure low permeability. Asphalt mixtures do not become measurably permeable to water until voids approach 8% (Brown, 1990).

At Hanford, experiments are ongoing on the development of a passive surface barrier designed to isolate wastes (in this case to prevent downward flux of water and upward flux of gases) for 1000 years with no maintenance. The surface barrier uses asphalt as one of many horizontal components because low-air-void, high-asphalt-content materials are noted for low permeability and improved mechanically stable compositions. The design objective of this asphalt concrete was to limit infiltration to 1.6×10^{-9} cm/s (1.6×10^{-11} m/s, or for fresh water, an intrinsic permeability of 1.6×10^{-18} m²). The asphalt component of the barrier is composed of a 15 cm layer of asphaltic concrete overlain with a 5-mm layer of fluid-applied asphalt. The reported hydraulic conductivity of the asphalt concrete is estimated to be 1×10^{-9} m/s (equivalent to an intrinsic permeability of approximately 1×10^{-16} m² assuming fresh water). Myers and Duranceau (1994) report that the hydraulic conductivity of fluid-applied asphalt is estimated to be 1.0×10^{-11} to 1.0×10^{-10} cm/s (equivalent to an intrinsic permeability of approximately 1.0×10^{-20} to 1.0×10^{-19} m² assuming fresh water).

Consideration of published values results in a lowest practical permeability of 1×10^{-21} m². The upper limit of the asphalt seal permeability is assumed to be 1×10^{-18} m². Intrinsic permeability of the asphalt column is defined as a log triangular distributed parameter, with a best estimate value of 1×10^{-20} m², a minimum value of 1×10^{-21} m², and a maximum value of 1×10^{-18} m², as shown in Figure G2A-5. It is recognized that the halite DRZ in the uppermost portion of the Salado Formation is not likely to heal because creep of salt is relatively slow.

These values are used in performance assessment of regulatory compliance analyses and in fluid flow calculations (Appendix C of the Compliance Submittal Design Report (Sandia, 1996)) pertaining to seal system functional evaluation. Other calculations pertaining to rock mechanics and structural considerations of asphalt elements are discussed in Appendix D of the Compliance Submittal Design Report (Sandia, 1996).

A2.3.5 Verification Methods

Viscosity of the AMM must be low enough for easy delivery through a heated slickline. Sufficient text book information is available to assure performance of the asphalt component; however, laboratory validation tests may be desirable before installation. There are no plans to test asphalt components after they are placed. With that in mind, some general tests identified below would add quantitative documentation to expected performance values and have direct application to WIPP. The types and objectives of the verification tests are:

Mix Design. A standard mix design which evaluates a combination of asphalt and aggregate mixtures would quantify density, air voids, viscosity, and permeability. Although the specified mixture will function adequately, studies could optimize the mix design.

Viscoelastic Properties at Service Temperatures. Viscoelastic properties over the range of expected service temperatures would refine the rheological model.

Accelerated Aging Analysis. Asphalt longevity issues could be further addressed by using the approach detailed in PNL-Report 9336 (Freeman and Romine, 1994).

Brine Susceptibility Analysis. The presumed inert nature of the asphalt mix can be demonstrated through exposure to groundwater brine solutions found in the Salado Formation. Potential for degradation will be characterized by monitoring the presence of asphalt degradation products in WIPP brine or brine simulant as a function of time. Effects on hydraulic conductivity can be measured during these experiments.

A2.4 Compacted Salt Column

A reconstituted salt column has been proposed as a primary means to isolate for several decades those repositories containing hazardous materials situated in evaporite sequences. Reuse of salt excavated in the process of creating the underground openings has been advocated since the initial proposal by the NAS in the 1950s. Replacing the natural material to its original setting ensures physical, chemical, and mechanical compatibility with the host formation. Recent developments in support of the WIPP shaft seal system have produced confirming experimental results, constitutive material laws, and construction methods that substantiate use of a salt column for a low permeability, perfectly compatible seal component.

Numerical models of the shaft and seal system have been used to provide information on the mechanical processes that affect potential pathways and overall performance of the seal system. Several of these types of analyses are developed in Appendix D of the Compliance Submittal Design Report (Sandia, 1996). Simulations of the excavated shaft and the compacted salt seal element behavior after placement show that as time passes, the host salt creeps inward, the compacted salt is loaded by the host formation and consolidates, and a back pressure is developed along the shaft wall. The back pressure imparted to the host formation by the compacted salt promotes healing of any microcracks in the host rock. As compacted salt consolidates, density and stiffness increase and permeability decreases.

A2.4.1 Functions

The function of the compacted and reconsolidated salt column is to limit transmission of fluids into or out of the repository for the statutory period of 10,000 years. The functional period starts within a hundred years and lasts essentially forever. After a period of consolidation, the salt column will almost completely retard gas or brine migration within the former shaft opening. A completely consolidated salt column will achieve flow properties indistinguishable from natural Salado salt.

A2.4.2 Material Characteristics

The salt component comprises crushed Salado salt with addition of small amounts of water. No admixtures other than water are needed to meet design specifications. Natural Salado salt (also called WIPP salt) is typical of most salts in the Permian Basin: it has an overall composition approaching 90-95 % halite with minor clays, carbonate, anhydrite, and other halite minerals. Secondary minerals and other impurities are of little consequence to construction or performance of the compacted salt column as long as the halite content is approximately 90 %.

The total water content of the crushed salt should be approximately 1.5 wt% as it is tamped into place. Field and laboratory testing verified that natural salt can be compacted to significant density ($\rho \geq 0.9$) with addition of these modest amounts of water. In situ WIPP salt contains approximately 0.5 wt% water. After it is mined, transported, and stored, some of the connate water is lost to evaporation and dehydration. Water content of the bulk material that would be used for compaction in the shaft is normally quite small, on the order of 0.25 wt%, as measured during compaction demonstrations (Hansen and Ahrens, 1996). Measurements of water content of the salt will be necessary periodically during construction to calibrate the proper amount of water to be added to the salt as it is placed.

Water added to the salt will be sprayed in a fine mist onto the crushed salt as it is cast in each lift. Methods similar to those used in the large-scale compaction demonstration will be developed such that the spray visibly wets the salt grain surfaces. General uniformity of spray is desired. The water has no special chemical requirements for purity. It can be of high quality (drinkable) but need not be potable. Brackish water would suffice because water of any quality would become brackish upon application to the salt.

The mined salt will be crushed and screened to a nominal maximum diameter of 5 mm. Gradation of particles smaller than 5 mm is not of concern because the crushing process will create relatively few fines compared to the act of dynamic compaction. Based on preliminary large-scale demonstrations, excellent compaction was achieved without optimization of particle sizes. It is evident from results of the large compaction demonstration coupled with laboratory

studies that initial density can be increased and permeability decreased beyond existing favorable results. Further demonstrations of techniques, including crushing and addition of water may be undertaken in ensuing years between compliance certification and beginning of seal placement.

A2.4.3 Construction

Dynamic compaction is the specified procedure to tamp crushed salt in the shaft. Other techniques of compaction have potential, but their application has not been demonstrated. Deep dynamic compaction provides the greatest energy input to the crushed salt, is easy to apply, and has an effective depth of compactive influence far greater than lift thickness. Dynamic compaction is relatively straightforward and requires a minimal work force. If the number of drops remains constant, diameter and weight of the tamper increases in proportion to the diameter of the shaft. The weight of the tamper is a factor in design of the infrastructure supporting the hoisting apparatus. Larger, heavier tampers require equally stout staging. The construction method outlined in Appendix B balances these opposing criteria. Compaction itself will follow the successful procedure developed in the large-scale compaction demonstration (Hansen and Ahrens, 1996).

Transport of crushed salt to the working level can be accomplished by dropping it down a slickline. As noted, additional water will be sprayed onto the crushed salt at the bottom of the shaft as it is placed. Lift heights of approximately 2 m are specified, though greater depths could be compacted effectively using dynamic compaction. Uneven piles of salt can be hand leveled.

A2.4.4 Performance Requirements

Compacted crushed salt is a unique seal material because it consolidates naturally as the host formation creeps inward. As the crushed salt consolidates, void space diminishes, density increases, and permeability decreases. Thus, sealing effectiveness of the compacted salt column will improve with time. Laboratory testing over the last decade has shown that pulverized salt specimens can be compressed to high densities and low permeabilities (Brodsky et al., 1996). In addition, consolidated crushed salt uniquely guarantees chemical and mechanical compatibility with the host salt formation. Therefore, crushed salt will provide a seal that will function essentially forever once the consolidation process is completed. Primary performance results of these analyses include plots of fractional density as a function of depth and time for the crushed salt column and permeability distribution functions that will be used for performance assessment calculations. These performance results are summarized near the end of this section, following a limited background discussion.

To predict performance, a constitutive model for crushed salt is required. To this end, a technical evaluation of potential crushed salt constitutive models was completed (Callahan et al., 1996). Ten potential crushed salt constitutive models were identified in a literature search to describe the phenomenological and micromechanical processes governing consolidation of crushed salt. Three of the ten potential models were selected for rigorous comparisons to a specially developed, although somewhat limited, database. The database contained data from hydrostatic and shear consolidation laboratory experiments. The experiments provide deformation (strain) data as a function of time under constant stress conditions. Based on volumetric strain measurements from experiments, change in crushed salt density and porosity are known. In some experiments, permeability was also measured, which provides a relationship between density and permeability of crushed salt. Models were fit to the

experimental database to determine material parameter values and the model that best represents experimental data.

Modeling has been used to predict consolidating salt density as a function of time and position in the shaft. Position or depth of the calculation is important because creep rates of intact salt and crushed salt are strong functions of stress difference. Analyses made use of a "pineapple" slice structural model at the top (430 m), middle (515 m), and bottom (600 m) of the compacted salt column. Initial fractional density of the compacted crushed salt was 0.90 (1944 kg m⁻³). The structural model, constitutive material models, boundary conditions, etc. are described in Appendix D of the Compliance Submittal Design Report (Sandia, 1996). Modeling results coupled with laboratory-determined relationships between density and permeability were used to develop distribution functions for permeability of the compacted crushed salt column for centuries after seal emplacement.

Analyses used reference engineering values for parameters in the constitutive models (e.g., the creep model for intact salt and consolidation models for crushed salt). Some uncertainty associated with model parameters exists in these constitutive models. Consolidating salt density was quantified by predicting density at specific times using parameter variations. Many of these types of calculations comparing three models for consolidation of crushed salt were performed to quantify performance of the salt column, and the reader is referred to Appendix D of the Compliance Submittal Design Report (Sandia, 1996) for more detail.

Predictions of fractional density as a function of time and depth are shown in Figure G2A-6. Performance calculations of the seal system require quantification of the resultant salt permeability. The permeability can be derived from the experimental data presented in Figure G2A-7. This plot depicts probabilistic lines through the experimental data. From these lines, distribution functions can be derived. Permeability of the compacted salt column is treated as a transient random variable defined by a log triangular distribution. Distribution functions were provided for 0, 50, 100, 200, and 400 years after seal emplacement, assuming that fluids in the salt column pores spaces would not produce a backstress. The resultant cumulative frequency distribution for seal permeability at the seal mid-height is shown in Figure G2A-8. This method predicts permeabilities ranging from 1×10^{-23} m² to 1×10^{-16} m². Because crushed salt consolidation will be affected by both mechanical and hydrological processes, detailed calculations were performed. These calculations are presented in Appendices C and D.

Numerical models of the shaft provide density of the compacted salt column as a function of depth and time. From the density-permeability relationship, permeability of the compacted salt seal component can be calculated. Similarly, the extent of the disturbed rock zone around the shaft is provided by numerical models. From field measurements of the halite DRZ, permeability of the DRZ is known as a function of depth and time. These spatial and temporal permeability values provide information required to assess the potential for brine and gas movement in and around the consolidating salt column.

A2.4.5 Verification Methods

Results of the large-scale dynamic compaction demonstration suggest that deep dynamic compaction will produce a dense starting material, and laboratory work and modeling show that compacted salt will reconsolidate within several decades to an essentially impermeable mass. As with other seal components, testing of the material in situ will be difficult and probably not the best way to ensure quality of the seal element. This is particularly apparent for the compacted

salt component because the compactive effort produces a finely powdered layer on the top of each lift. It turns out that the fine powder compacts into a very dense material when the next lift is compacted. The best way to ensure that the crushed salt element functions properly is to establish performance through QA/QC procedures. If crushed salt is placed with a reasonable uniformity of water and is compacted with sufficient energy, long-term performance can be assured.

Periodic measurements of the water content of loose salt as it is placed in lifts will be used for verification and quality control. Thickness of lifts will be controlled. Energy imparted to each lift will be documented by logging drop patterns and drop height. If deemed necessary, visual inspection of the tamped salt can be made by human access. The powder layer can be shoveled aside and hardness of underlying material can be qualitatively determined or tested. Overall geometric measurements made from the original surface of each lift could be used to approximate compacted density.

A2.5 Cementitious Grout

Cementitious grouting is specified for all concrete members in response to external review suggestions. Grouting is also used in advance of liner removal to stabilize the ground. Cementitious grout is specified because of its proven performance, nontoxicity, and previous use at the WIPP.

A2.5.1 Functions

The function of grout is to stabilize the surrounding rock before existing concrete liners are removed. Grout will fill fractures within adjacent lithologies, thereby adding strength and reducing permeability. Grout around concrete members of the concrete asphalt waterstop will be employed in an attempt to tighten the interface and fill microcracks in the DRZ. Efficacy of grouting will be determined during construction. In addition, reduction of local permeability will further limit groundwater influx into the shaft during construction. Concrete plugs are planned for specific elevations in the lined portion of each shaft. The formation behind the concrete liner will be grouted from approximately 3 m below to 3 m above the plug positions to ensure stability of any loose rock.

A2.5.2 Material Characteristics

The grout developed for use in the shaft seal system has the following characteristics:

- no water separation upon hydration,
- low permeability paste,
- fine particle size,
- low hydrational heat,
- no measurable agglomeration subsequent to mixing,
- two hours of injectability subsequent to mixing,
- short set time,
- high compressive strength, and
- competitive cost.

A cementitious grout developed by Ahrens and coworkers (Ahrens et al., 1996) is specified for application in the shaft seal design. This grout consists of portland cement, pumice as a pozzolanic material, and superplasticizer in the proportions listed in Table A-10. The ultrafine grout is mixed in a colloidal grout mixer, with a water to components ratio (W:C) of 0.6:1. Grout has been produced with 90 % of the particles smaller than 5 microns and an average particle size of 2 microns. The extremely small particle size enables the grout to penetrate fractures with apertures as small as 6 microns.

Table A-10
Ultrafine Grout Mix Specification

Component	Weight Percent (wt%)
Type 5 portland cement	45
Pumice	55
Superplasticizer	1.5

A2.5.3 Construction

Grout holes will be drilled in a spin pattern that extends from 3 m below to 3 m above that portion of the lining to be removed. The drilling and grouting sequence will be defined in the workmanship specifications prior to construction. Grout will be mixed on surface and transferred to the work deck via the slick line. Maximum injection pressure will be lithostatic, less 50 psig. It is estimated that four holes can be drilled and grouted per shift.

A2.5.4 Performance Requirements

Performance of grout is not a consideration for compliance issues. Grouting is used to facilitate construction by stabilizing any loose rock behind the concrete liner. If the country rock is fractured, grouting will reduce the permeability of the DRZ significantly. Application at the WIPP demonstrated permeability reduction in an anhydrite marker bed of two to three orders of magnitude (Ahrens et al., 1996). Reduction of local permeability adds to longevity of the grout itself and reduces the possibility of brine contacting seal elements. Because grout does not influence compliance issues, a model for it is not used and has not been developed. General performance achievements are:

- filled fractures as small as 6 microns,
- no water separation upon hydration,
- no evidence of halite dissolution,
- no measurable agglomeration subsequent to mixing,
- one hour of injectability,
- initial Vicat needle set in 2.5 hours,
- compressive strength 40 MPa at 28 days, and
- competitive cost.

A2.5.5 Verification Methods

No verification of the effectiveness of grouting is currently specified. If injection around concrete plugs is possible, an evaluation of quantities and significance of grouting will be made during

construction. Procedural specifications will include measurements of fineness and determination of rheology in keeping with processes established during the WIPP demonstration grouting (Ahrens et al., 1996).

A2.6 Earthen Fill

Compacted earthen fill comprise approximately 150 m of shaft fill in the Dewey Lake Redbeds and near surface stratigraphy.

A2.6.1 Functions

There are minimal performance requirements imposed for Components 1 and 3 and none that affect regulatory compliance of the site. Specifications for Components 1 and 3 are general: fill the shaft with relatively dense material to reduce subsidence.

A2.6.2 Material Characteristics

Fill can utilize material that was excavated during shaft sinking and stored at the WIPP site, or a borrow pit may be excavated to secure fill material. The bulk fill material may include bentonite additive, if deemed appropriate.

A2.6.3 Construction

Dynamic compaction is specified for the clay column in the Dewey Lake Formation because of its perceived expediency. Vibratory compaction will be used near surface when there is no longer space for the three stage construction deck.

A2.6.4 Performance Requirements

Care will be taken to compact the earthen fill with an energy of twice Modified Proctor energy, which has been shown to produce a dense, uniform fill.

A2.6.6 Verification

Materials placed will be documented, with density measurements as appropriate.

A3. CONCLUDING REMARKS

Material specifications in this appendix provide descriptions of seal materials along with reasoning about why they are expected to function well in the WIPP setting. The specification follows a framework that states the function of the seal component, a description of the material, and a summary of construction techniques that could be implemented without resorting to extensive development efforts. Discussion of performance requirements for each material is the most detailed section because design of the seal system requires analysis of performance to ascertain compliance with regulations. Successful design of the shaft seal system is demonstrated by an evaluation of how well the design performs, rather than by comparison with a predetermined quantity.

Materials chosen for use in the shaft seal system have several common desirable attributes: low permeability, availability, high density, longevity, low cost, constructability, and supporting

Waste Isolation Pilot Plant
Hazardous Waste Facility Permit
Attachment G2, Appendix G2-A
October 2023

documentation. Functional redundancy using different materials provides an economically and technologically feasible shaft seal system that limits fluid transport.

A4. REFERENCES

Ahrens, E.H., T.F. Dale, and R.S. Van Pelt. 1996. *Data Report on the Waste Isolation Pilot Plant Small-Scale Seal Performance Test, Series F Grouting Experiment*. SAND93-1000. Albuquerque, NM: Sandia National Laboratories. (Copy on file in the Sandia WIPP Central Files, Sandia National Laboratories, Albuquerque, NM [SWCF] as WPO37355.)

American Colloid Company. 1995. "Technical Data Sheet. Volclay GPG 30." Arlington Heights, IL: Industrial Chemical Division, American Colloid Company. 1 p. (Copy on file in the SWCF as WPO39636.)

American Petroleum Institute. 1990. "Specification for Materials and Testing for Well Cements." API Specification 10. 5th ed. Washington, DC: American Petroleum Institute. (Available from American Petroleum Institute, 1220 L St. NW, Washington, DC 20005, 202/682-8375.)

ASTM C 33 - 93. "Specification for Concrete Aggregates," *Annual Book of ASTM Standards, Volume 04.02, Concrete and Aggregates*. Philadelphia, PA: American Society for Testing and Materials. (Available from American Society for Testing and Materials, 1916 Race Street, Philadelphia, PA 19103-1187, 215/299-5400.)

ASTM C 39 - 94. "Test Method for Compressive Strength of Cylindrical Concrete Specimens," *Annual Book of ASTM Standards, Volume 04.02, Concrete and Aggregates*. Philadelphia, PA: American Society for Testing and Materials. (Available from American Society for Testing and Materials, 1916 Race Street, Philadelphia, PA 19103-1187, 215/299-5400.)

ASTM C 40 - 92. "Test Method for Organic Impurities in Fine Aggregates for Concrete," *Annual Book of ASTM Standards, Volume 04.02, Concrete and Aggregates*. Philadelphia, PA: American Society for Testing and Materials. (Available from American Society for Testing and Materials, 1916 Race Street, Philadelphia, PA 19103-1187, 215/299-5400.)

ASTM C 114 - 94. "Test Methods for Chemical Analysis of Hydraulic Cement," *Annual Book of ASTM Standards, Volume 04.01, Cement, Lime, Gypsum*. Philadelphia, PA: American Society for Testing and Materials. (Available from American Society for Testing and Materials, 1916 Race Street, Philadelphia, PA 19103-1187, 215/299-5400.)

ASTM C 117 - 95. "Test Method for Material Finer Than 75- μ m (No. 200) Sieve in Mineral Aggregates by Washing," *Annual Book of ASTM Standards, Volume 04.02, Concrete and Aggregates*. Philadelphia, PA: American Society for Testing and Materials. (Available from American Society for Testing and Materials, 1916 Race Street, Philadelphia, PA 19103-1187, 215/299-5400.)

ASTM C 123 - 94. "Test Method for Lightweight Pieces in Aggregate," *Annual Book of ASTM Standards, Volume 04.02, Concrete and Aggregates*. Philadelphia, PA: American Society for Testing and Materials. (Available from American Society for Testing and Materials, 1916 Race Street, Philadelphia, PA 19103-1187, 215/299-5400.)

ASTM C 127 - 88 (1993). "Test Method for Specific Gravity and Absorption of Coarse Aggregate," *Annual Book of ASTM Standards, Volume 04.02, Concrete and Aggregates*. Philadelphia, PA: American Society for Testing and Materials. (Available from American Society for Testing and Materials, 1916 Race Street, Philadelphia, PA 19103-1187, 215/299-5400.)

ASTM C 128 - 93. "Test Method for Specific Gravity and Absorption of Fine Aggregate," *Annual Book of ASTM Standards, Volume 04.02, Concrete and Aggregates*. Philadelphia, PA: American Society for Testing and Materials. (Available from American Society for Testing and Materials, 1916 Race Street, Philadelphia, PA 19103-1187, 215/299-5400.)

ASTM C 131 - 89. "Test Method for Resistance to Degradation of Small-Size Coarse Aggregate by Abrasion and Impact in the Los Angeles Machine," *Annual Book of ASTM Standards, Volume 04.02, Concrete and Aggregates*. Philadelphia, PA: American Society for Testing and Materials. (Available from American Society for Testing and Materials, 1916 Race Street, Philadelphia, PA 19103-1187, 215/299-5400.)

ASTM C 136 - 95a. "Test Method for Sieve Analysis of Fine and Coarse Aggregates," *Annual Book of ASTM Standards, Volume 04.02, Concrete and Aggregates*. Philadelphia, PA: American Society for Testing and Materials. (Available from American Society for Testing and Materials, 1916 Race Street, Philadelphia, PA 19103-1187, 215/299-5400.)

ASTM C 138 - 92. "Test Method for Unit Weight, Yield, and Air Content (Gravimetric) of Concrete," *Annual Book of ASTM Standards, Volume 04.02, Concrete and Aggregates*. Philadelphia, PA: American Society for Testing and Materials. (Available from American Society for Testing and Materials, 1916 Race Street, Philadelphia, PA 19103-1187, 215/299-5400.)

ASTM C 142 - 78 (1990). "Test Method for Clay Lumps and Friable Particles in Aggregates," *Annual Book of ASTM Standards, Volume 04.02, Concrete and Aggregates*. Philadelphia, PA: American Society for Testing and Materials. (Available from American Society for Testing and Materials, 1916 Race Street, Philadelphia, PA 19103-1187, 215/299-5400.)

ASTM C 143 - 90a. "Test Method for Slump of Hydraulic Cement Concrete," *Annual Book of ASTM Standards, Volume 04.02, Concrete and Aggregates*. Philadelphia, PA: American Society for Testing and Materials. (Available from American Society for Testing and Materials, 1916 Race Street, Philadelphia, PA 19103-1187, 215/299-5400.)

ASTM C 150 - 95. "Specification for Portland Cement," *Annual Book of ASTM Standards, Volume 04.01, Cement, Lime, Gypsum*. Philadelphia, PA: American Society for Testing and Materials. (Available from American Society for Testing and Materials, 1916 Race Street, Philadelphia, PA 19103-1187, 215/299-5400.)

ASTM C 157 - 93. "Test Method for Length Change of Hardened Hydraulic-Cement Mortar and Concrete," *Annual Book of ASTM Standards, Volume 04.02, Concrete and Aggregates*. Philadelphia, PA: American Society for Testing and Materials. (Available from American Society for Testing and Materials, 1916 Race Street, Philadelphia, PA 19103-1187, 215/299-5400.)

ASTM C 204 - 94a. "Test Method for Fineness of Hydraulic Cement by Air Permeability Apparatus," *Annual Book of ASTM Standards, Volume 04.01, Cement, Lime, Gypsum*. Philadelphia, PA: American Society for Testing and Materials. (Available from American Society for Testing and Materials, 1916 Race Street, Philadelphia, PA 19103-1187, 215/299-5400.)

ASTM C 231 - 91b. "Test Method for Air Content of Freshly Mixed Concrete by the Pressure Method," *Annual Book of ASTM Standards, Volume 04.02, Concrete and Aggregates*. Philadelphia, PA: American Society for Testing and Materials. (Available from American Society for Testing and Materials, 1916 Race Street, Philadelphia, PA 19103-1187, 215/299-5400.)

ASTM C 294 - 86 (1991). "Descriptive Nomenclature for Constituents of Natural Mineral Aggregates," *Annual Book of ASTM Standards, Volume 04.02, Concrete and Aggregates*. Philadelphia, PA: American Society for Testing and Materials. (Available from American Society for Testing and Materials, 1916 Race Street, Philadelphia, PA 19103-1187, 215/299-5400.)

ASTM C 295 - 90. "Guide for Petrographic Examination of Aggregates for Concrete," *Annual Book of ASTM Standards, Volume 04.02, Concrete and Aggregates*. Philadelphia, PA: American Society for Testing and Materials. (Available from American Society for Testing and Materials, 1916 Race Street, Philadelphia, PA 19103-1187, 215/299-5400.)

ASTM C 311 - 94b. "Test Methods for Sampling and Testing Fly Ash or Natural Pozzolans for Use as a Mineral Admixture in Portland-Cement Concrete," *Annual Book of ASTM Standards, Volume 04.02, Concrete and Aggregates*. Philadelphia, PA: American Society for Testing and Materials. (Available from American Society for Testing and Materials, 1916 Race Street, Philadelphia, PA 19103-1187, 215/299-5400.)

ASTM C 469 - 94. "Test Method for Static Modulus of Elasticity and Poisson's Ratio of Concrete in Compression," *Annual Book of ASTM Standards, Volume 04.02, Concrete and Aggregates*. Philadelphia, PA: American Society for Testing and Materials. (Available from American Society for Testing and Materials, 1916 Race Street, Philadelphia, PA 19103-1187, 215/299-5400.)

ASTM C 534 - 94. "Specification for Preformed Flexible Elastomeric Cellular Thermal Insulation in Sheet and Tubular Form," *Annual Book of ASTM Standards, Volume 04.06, Thermal Insulation; Environmental Acoustics*. Philadelphia, PA: American Society for Testing and Materials. (Available from American Society for Testing and Materials, 1916 Race Street, Philadelphia, PA 19103-1187, 215/299-5400.)

ASTM C 535 - 89. "Test Method for Resistance to Degradation of Large-Size Coarse Aggregate by Abrasion and Impact in the Los Angeles Machine," *Annual Book of ASTM Standards, Volume 04.02, Concrete and Aggregates*. Philadelphia, PA: American Society for Testing and Materials. (Available from American Society for Testing and Materials, 1916 Race Street, Philadelphia, PA 19103-1187, 215/299-5400.)

ASTM C 566 - 95. "Test Method for Total Moisture Content of Aggregate by Drying," *Annual Book of ASTM Standards, Volume 04.02, Concrete and Aggregates*. Philadelphia, PA: American Society for Testing and Materials. (Available from American Society for Testing and Materials, 1916 Race Street, Philadelphia, PA 19103-1187, 215/299-5400.)

ASTM C 618 - 95. "Specification for Coal Fly Ash and Raw or Calcined Natural Pozzolan for Use as a Mineral Admixture in Portland Cement Concrete," *Annual Book of ASTM Standards, Volume 04.02, Concrete and Aggregates*. Philadelphia, PA: American Society for Testing and Materials. (Available from American Society for Testing and Materials, 1916 Race Street, Philadelphia, PA 19103-1187, 215/299-5400.)

ASTM C 845 - 90. "Specification for Expansive Hydraulic Cement," *Annual Book of ASTM Standards, Volume 04.01, Cement; Lime; Gypsum*. Philadelphia, PA: American Society for Testing and Materials. (Available from American Society for Testing and Materials, 1916 Race Street, Philadelphia, PA 19103-1187, 215/299-5400.)

ASTM C 1064 - 86 (1993). "Test Method for Temperature of Freshly Mixed Portland Cement Concrete," *Annual Book of ASTM Standards, Volume 04.02, Concrete and Aggregates*. Philadelphia, PA: American Society for Testing and Materials. (Available from American Society for Testing and Materials, 1916 Race Street, Philadelphia, PA 19103-1187, 215/299-5400.)

ASTM C 1077 - 95a. "Practice for Laboratories Testing Concrete and Concrete Aggregates for Use in Construction and Criteria for Laboratory Evaluation," *Annual Book of ASTM Standards, Volume 04.02, Concrete and Aggregates*. Philadelphia, PA: American Society for Testing and Materials. (Available from American Society for Testing and Materials, 1916 Race Street, Philadelphia, PA 19103-1187, 215/299-5400.)

ASTM D 1556 - 90. "Test Method for Density and Unit Weight of Soil in Place by the Sand-Cone Method," *Annual Book of ASTM Standards, Volume 04.08, Soil and Rock*. Philadelphia, PA: American Society for Testing and Materials. (Available from American Society for Testing and Materials, 1916 Race Street, Philadelphia, PA 19103-1187, 215/299-5400.)

ASTM D 2167 - 94. "Test Method for Density and Unit Weight of Soil in Place by the Rubber Balloon Method," *Annual Book of ASTM Standards, Volume 04.08, Soil and Rock*. Philadelphia, PA: American Society for Testing and Materials. (Available from American Society for Testing and Materials, 1916 Race Street, Philadelphia, PA 19103-1187, 215/299-5400.)

ASTM D 2216 - 92. "Test Method for Laboratory Determination of Water (Moisture) Content of Soil and Rock," *Annual Book of ASTM Standards, Volume 04.08, Soil and Rock*. Philadelphia, PA: American Society for Testing and Materials. (Available from American Society for Testing and Materials, 1916 Race Street, Philadelphia, PA 19103-1187, 215/299-5400.)

ASTM D 2922 - 91. "Test Methods for Density of Soil and Soil-Aggregate in Place by Nuclear Methods (Shallow Depth)," *Annual Book of ASTM Standards, Volume 04.08, Soil and Rock*. Philadelphia, PA: American Society for Testing and Materials. (Available from American Society for Testing and Materials, 1916 Race Street, Philadelphia, PA 19103-1187, 215/299-5400.)

ASTM D 3017 - 88 (1993). "Test Method for Water Content of Soil and Rock in Place by Nuclear Methods (Shallow Depth)," *Annual Book of ASTM Standards, Volume 04.08, Soil and Rock*. Philadelphia, PA: American Society for Testing and Materials. (Available from American Society for Testing and Materials, 1916 Race Street, Philadelphia, PA 19103-1187, 215/299-5400.)

ASTM D 4791 - 95. "Test Method for Flat or Elongated Particles in Coarse Aggregate," *Annual Book of ASTM Standards, Volume 04.03, Road and Paving Materials; Pavement Management Technologies*. Philadelphia, PA: American Society for Testing and Materials. (Available from American Society for Testing and Materials, 1916 Race Street, Philadelphia, PA 19103-1187, 215/299-5400.)

ASTM E 534 - 91. "Test Methods for Chemical Analysis of Sodium Chloride," *Annual Book of ASTM Standards, Volume 15.05, Engine Coolants; Halogenated Organic Solvents; Industrial Chemicals*. Philadelphia, PA: American Society for Testing and Materials. (Available from American Society for Testing and Materials, 1916 Race Street, Philadelphia, PA 19103-1187, 215/299-5400.)

Brodsky, N.S., F.D. Hansen, and T.W. Pfeifle. 1996. "Properties of Dynamically Compacted WIPP Salt," *4th International Conference on the Mechanical Behavior of Salt, Montreal*,

Quebec, June 17-18, 1996. SAND96-0838C. Albuquerque, NM: Sandia National Laboratories. (Copy on file at the Technical Library, Sandia National Laboratories, Albuquerque, NM.)

Brown, E.R. 1990. "Density of Asphalt Concrete--How Much is Needed?," *Transportation Research Record No. 1282*. Washington, DC: Transportation Research Board. 27-32. (Copy on file in the SWCF.)

Callahan, G.D., M.C. Loken, L.D. Hurtado, and F.D. Hansen. 1996. "Evaluation of Constitutive Models for Crushed Salt," *4th International Conference on the Mechanical Behavior of Salt, Montreal, Quebec, June 17-18, 1996*. SAND96-0791C. Albuquerque, NM: Sandia National Laboratories. (Copy on file in the SWCF as WPO36449.)

Cheung, S.C.H., M.N. Gray, and D.A. Dixon. 1987. "Hydraulic and Ionic Diffusion Properties of Bentonite-Sand Buffer Materials," *Coupled Processes Associated with Nuclear Waste Repositories, Proceedings of the International Symposium on Coupled Processes Affecting the Performance of a Nuclear Waste Repository, Berkeley, CA, September 18-20, 1985*. Ed. C-F. Tsang. Orlando, FL: Academic Press, Inc. 383-407. (Copy on file in the SWCF.)

CRD-C 38 - 73. "Method of Test for Temperature Rise in Concrete," *Handbook for Concrete and Cement*. Vicksburg, MS: U.S. Army Corps of Engineers, Waterways Experiment Station. (Copy on file in the SWCF as WPO39656.)

DOE (U.S. Department of Energy). 1995. *Waste Isolation Pilot Plant Sealing System Design Report*. DOE/WIPP-95-3117. Carlsbad, NM: U.S. Department of Energy, Waste Isolation Pilot Plant. (Copy on file in the SWCF as WPO29062.)

EPA (Environmental Protection Agency). 1996a. *Criteria for the Certification and Re-Certification of the Waste Isolation Pilot Plant's Compliance with the 40 CFR Part 191 Disposal Regulations. Response to Comments Document for 40 CFR Part 194*. EPA 402-R-96-001. Washington, DC: Environmental Protection Agency, Office of Radiation and Indoor Air. (Copy on file in the Nuclear Waste Management Library, Sandia National Laboratories, Albuquerque, NM.)

EPA (Environmental Protection Agency). 1996b. *Criteria for the Certification and Re-Certification of the Waste Isolation Pilot Plant's Compliance with the 40 CFR Part 191 Disposal Regulations. Background Information Document for 40 CFR Part 194*. EPA 402-R-96-002. Washington, DC: Environmental Protection Agency, Office of Radiation and Indoor Air. (Copy on file in the Nuclear Waste Management Library, Sandia National Laboratories, Albuquerque, NM.)

Freeman, H.D., and R.A. Romine. 1994. *Hanford Permanent Isolation Barrier Program: Asphalt Technology Test Plan*. PNL-9336. Richland, WA: Pacific Northwest Laboratories. (Copy available from National Technical Information Service, 5285 Port Royal Road, Springfield, VA, 22161, 703/487-4650. Order number: DE94013454.)

Gray, M.N. 1993. *OECD/NEA International Stripa Project. Overview Volume III: Engineered Barriers*. Stockholm, Sweden: SKB, Swedish Nuclear Fuel and Waste Management Company. (Copy on file in the Nuclear Waste Management Library, Sandia National Laboratories, Albuquerque, NM as TD898.2 .G73 1993.)

Hansen, F.D., and E.H. Ahrens. 1996. "Large-Scale Dynamic Compaction of Natural Salt," *4th International Conference on the Mechanical Behavior of Salt, Montreal, Quebec, June 17-18, 1996*. SAND96-0792C. Albuquerque, NM: Sandia National Laboratories. (Copy on file in the SWCF as WPO39544.)

IAEA (International Atomic Energy Agency). 1990. *Sealing of Underground Repositories for Radioactive Wastes*. STI/DOC/10/319. Technical Reports Series No. 319. Vienna, Austria: International Atomic Energy Agency; Lanham, MD: Unipub. (Copies on file at the Technical Library, Sandia National Laboratories, Albuquerque, NM and at Centennial Science and Engineering Library, University of New Mexico, Albuquerque, NM.)

Kjartanson, B.H., N.A. Chandler, A.W.L. Wan, C.L. Kohle, and P.J. Roach. 1992. "Use of a Method Specification for In Situ Compaction of Clay-Based Barrier Materials," *High Level Radioactive Waste Management, Proceedings of the Third International Conference, Las Vegas, NV, April 12-16, 1992*. La Grange Park, IL: American Nuclear Society, Inc.; New York, NY: American Society of Civil Engineers. Vol. 1, 1129-1136. (Copy on file in the SWCF.)

Knowles, M.K., and C.L. Howard. 1996. "Field and Laboratory Testing of Seal Materials Proposed for the Waste Isolation Pilot Plant," *Proceedings of the Waste Management 1996 Symposium, Tucson, AZ, February 25-29, 1996*. SAND95-2082C. Albuquerque, NM: Sandia National Laboratories. (Copy on file in the SWCF as WPO30945.)

Mitchell, J.K. 1993. *Fundamentals of Soil Behavior*. 2nd ed. New York, NY: John Wiley & Sons, Inc.

Myers, D.R., and D.A. Duranceau. 1994. *Prototype Hanford Surface Barrier: Design Basis Document*. BHI-00007, Rev. 00. Richland, WA: Bechtel Hanford, Inc. for the U.S. Department of Energy, Office of Environmental Restoration and Waste Management. (Copy on file at the Nuclear Waste Management Library, Sandia National Laboratories, Albuquerque, NM.)

Nilsson, J. 1985. "Field Compaction of Bentonite-Based Backfilling," *Engineering Geology*. Vol. 21, no. 3-4, 367-376. (Copy on file in the SWCF.)

Onofrei, M., M.N. Gray, W.E. Coons, and S.R. Alcorn. 1992. "High Performance Cement-Based Grouts for Use in a Nuclear Waste Disposal Facility," *Waste Management*. Vol. 12, no. 2/3, 133-154. (Copy on file in the SWCF.)

Pfeifle, T.W., F.D. Hansen, and M.K. Knowles. 1996. "Salt-Saturated Concrete Strength and Permeability," *4th Materials Engineering Conference, ASCE Materials Engineering Division, Washington, DC, November 11-18, 1996*. Albuquerque, NM: Sandia National Laboratories.)

Pusch, R. 1982. "Mineral-Water Interactions and Their Influence on the Physical Behavior of Highly Compacted Na Bentonite," *Canadian Geotechnical Journal*. Vol. 19, no. 3, 381-387. (Copy on file in the SWCF.)

Pusch, R., and L. Börgesson. 1989. "Bentonite Sealing of Rock Excavations," *Sealing of Radioactive Waste Repositories, Proceedings of an NEA/CEC Workshop, Braunschweig, Germany, May 22-25, 1989*. EUR 12298. Paris: Organisation for Economic Co-Operation and Development. 297-308. (Copy on file in the SWCF.)

Waste Isolation Pilot Plant
Hazardous Waste Facility Permit
Attachment G2, Appendix G2-A
October 2023

Pusch, R., M. Gray, F. Huertas, M. Jorda, A. Barbreau, and R. Andre-Jehan. 1989. "Sealing of Radioactive Waste Repositories in Crystalline Rock," *Sealing of Radioactive Waste Repositories, Proceedings of an NEA/CEC Workshop, Braunschweig, Germany, May 22-25, 1989*. EUR 12298. Paris: Organisation for Economic Co-Operation and Development. 214-228. (Copy on file in the SWCF.)

Sandia (Repository Isolation Systems Department 6121). 1996. *Waste Isolation Pilot Plant Shaft Sealing System Compliance Submittal Design Report*. SAND96-1326/1&2. Albuquerque, NM: Sandia National Laboratories.

Wakeley, L.D., P.T. Harrington, and F.D. Hansen. 1995. *Variability in Properties of Salado Mass Concrete*. SAND94-1495. Albuquerque, NM: Sandia National Laboratories. (Copy on file in the SWCF as WPO22744.)

Wing, N.R., and G.W. Gee. 1994. "Quest for the Perfect Cap," *Civil Engineering*. Vol. 64, no. 10, 38-41. (Copy on file in the SWCF as WPO21158.)

FIGURES

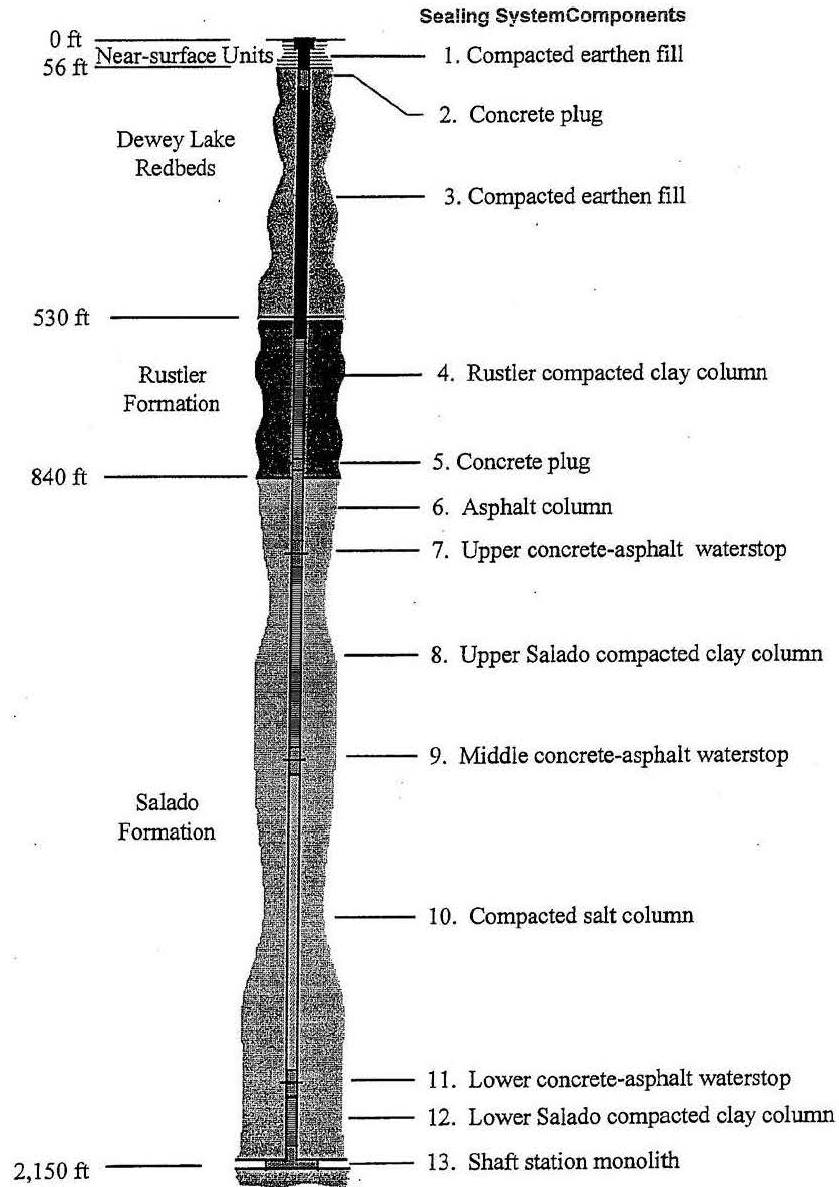

Figure G2A-1
Schematic of the WPP Shaft Seal Design

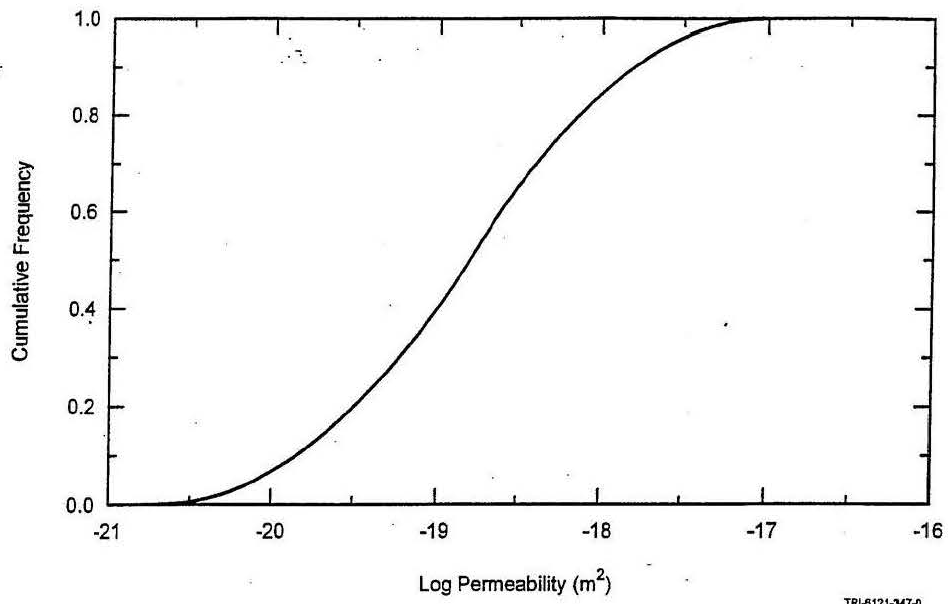
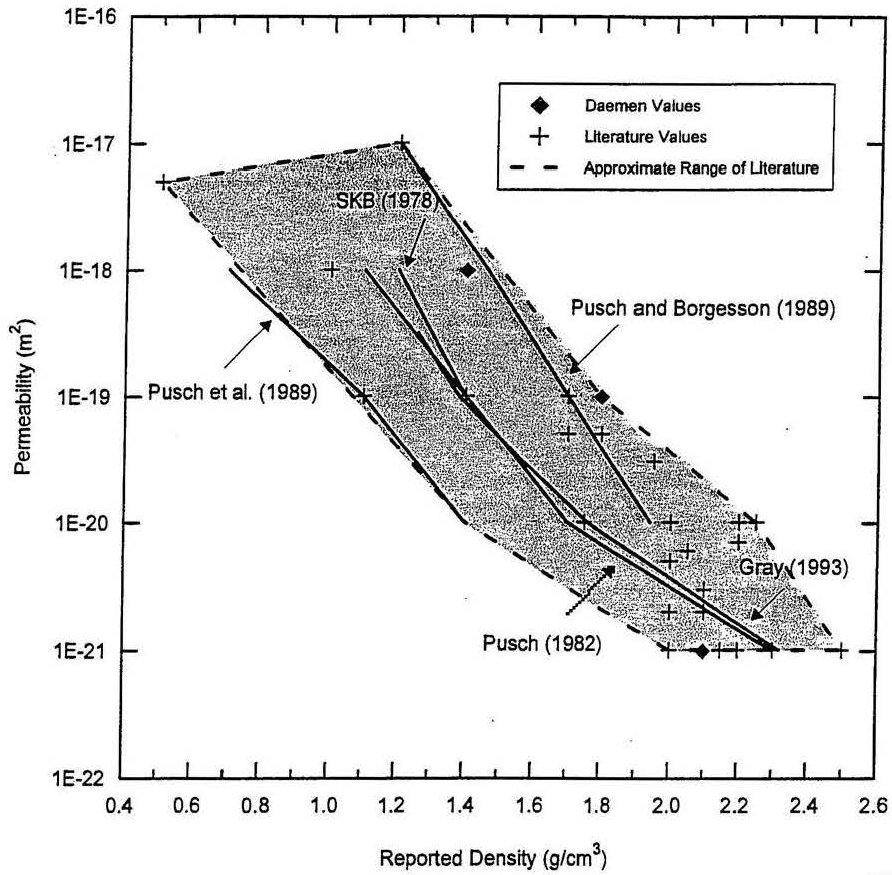

Figure G2A-2
Cumulative Distribution Function for SMC



TRI-6121-360-1

Figure G2A-3
Sodium Bentonite Permeability Versus Density

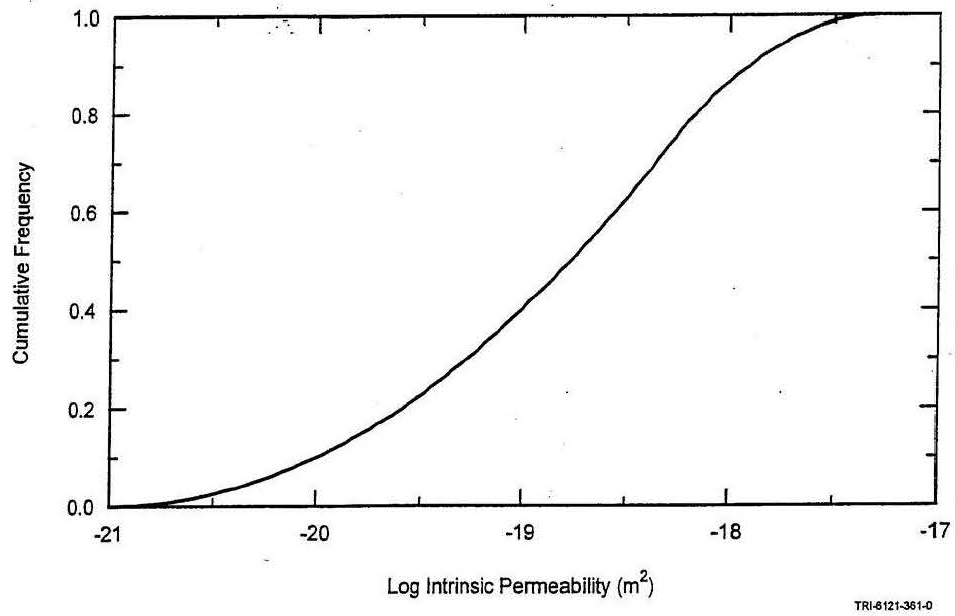

Figure G2A-4
Cumulative Frequency Distribution for Compacted Bentonite

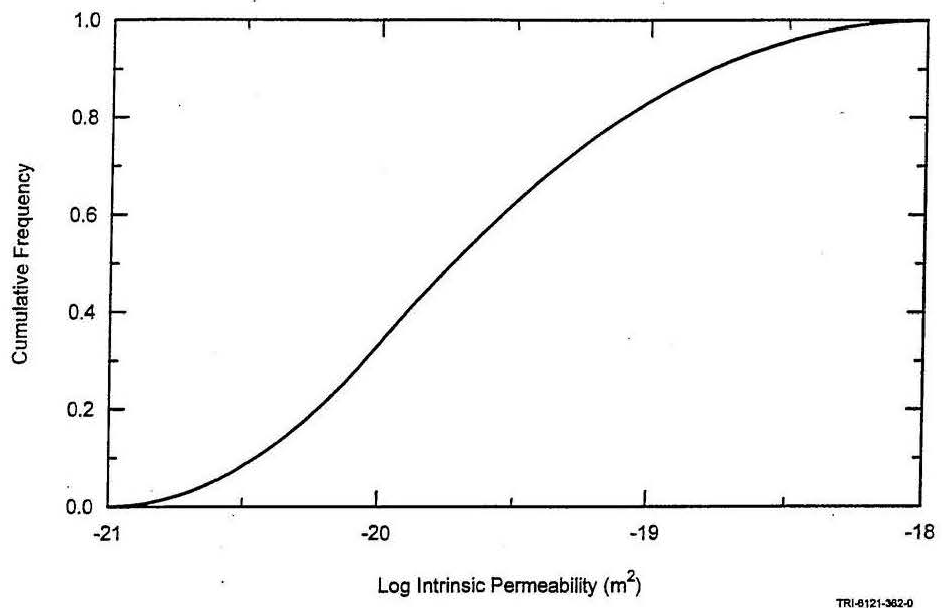

Figure G2A-5
Asphalt Permeability Cumulative Frequency Distribution Function

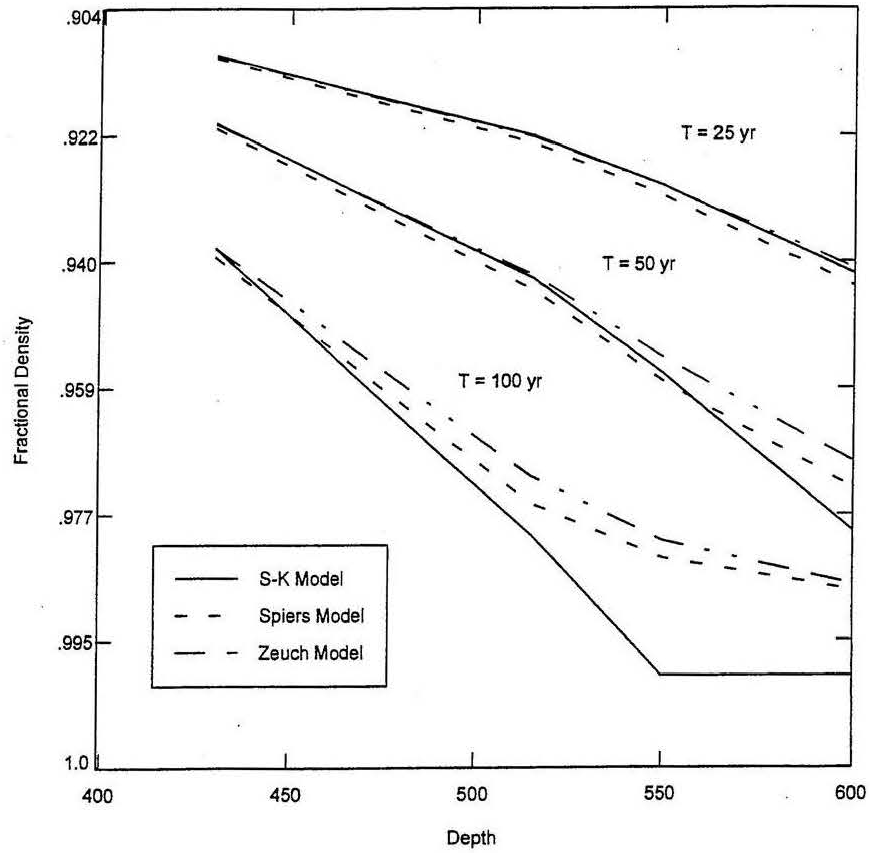

Figure G2A-6
Fractional Density of the Consolidating Salt Column

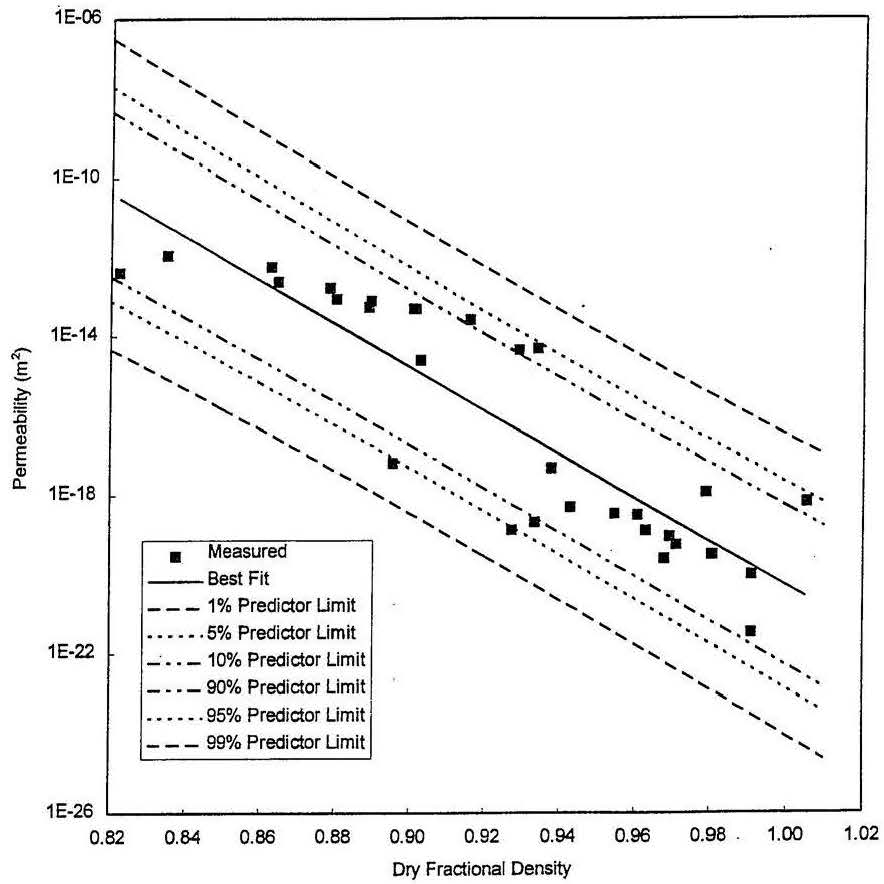
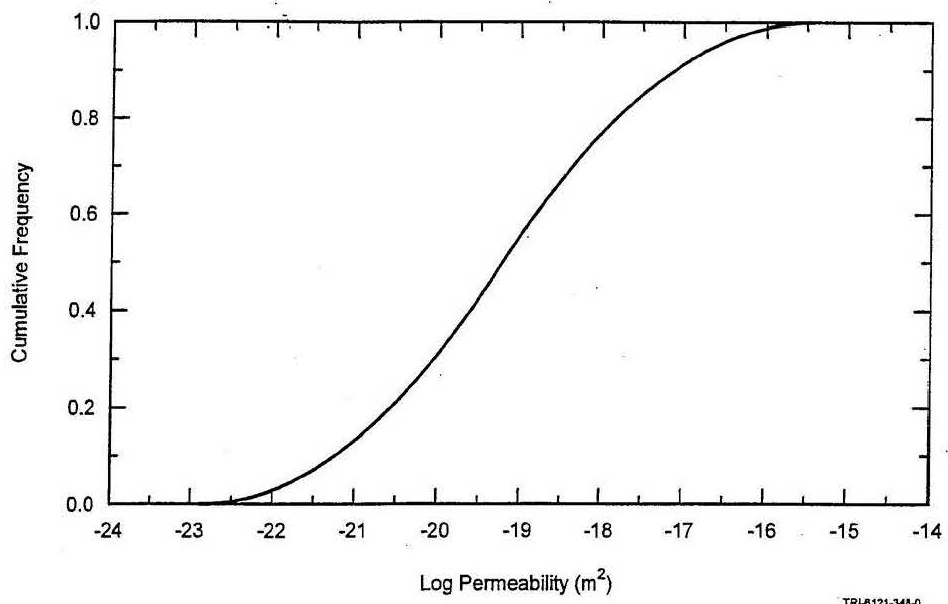

Figure G2A-7
Permeability of Consolidated Crushed Salt as a Function of Fractional Density



TRI-6121-348-0

Figure G2A-8
Compacted Salt Column Permeability Cumulative Frequency Distribution Function at Seal
Midpoint 100 Years Following Closure

**ATTACHMENT G2
APPENDIX G2-B**

SHAFT SEALING CONSTRUCTION PROCEDURES

**SHAFT SEALING SYSTEM
COMPLIANCE SUBMITTAL DESIGN REPORT**

**ATTACHMENT G2
APPENDIX G2-B**

SHAFT SEALING CONSTRUCTION PROCEDURES

**SHAFT SEALING SYSTEM
COMPLIANCE SUBMITTAL DESIGN REPORT**

Appendix B Abstract

This appendix describes equipment and procedures used to construct the shaft seals as specified in Permit Attachment G2. Existing or reasonably modified construction equipment is specified, standard mining practices are applied, and a general schedule is provided at the end of this appendix. This appendix describes the following activities:

- pre-sealing activities for the sub-surface and surface,
- construction and operation of a multi-deck stage,
- installation of special concrete (sumps, shaft station monoliths, and concrete plugs),
- installation of compacted clay columns,
- emplacement and dynamic compaction of WIPP salt,
- installation of neat asphalt and asphaltic mastic mix,
- grouting of concrete plugs and the country rock behind existing shaft liners,
- removal of portions of the existing shaft liners, and
- emplacement of compacted earthen fill.

TABLE OF CONTENTS

B1.	Introduction	4
B2.	Project Mobilization	5
	B2.1 Subsurface	5
	B2.2 Surface	5
	B2.3 Installation of Utilities	6
B3.	Multi-Deck Stage	7
B4.	Placement of Sealing Materials	8
	B4.1 Concrete	9
	B4.1.1 Shaft Station Monolith	9
	B4.1.2 Concrete-Asphalt Waterstops	10
	B4.1.3 Concrete Plugs	10
	B4.2 Clay	10
	B4.2.1 Salado and Rustler Compacted Clay Column	10
	B4.3 Asphalt	11
	B4.3.1 Concrete-Asphalt Waterstops	11
	B4.3.2 Asphaltic Mastic Mix Column	13
	B4.4 Compacted Salt Column	14
	B4.5 Grout	16
	B4.6 Compacted Earthen Fill	17
	B4.6.1 Lower Section	17
	B4.6.2 Upper Section	18
	B4.7 Schedule	18
B5.	References	45

FIGURES

Figure	Title
Figure G2B-1	Multi-Deck Stage Illustrating Dynamic Compaction
Figure G2B-2	Multi-Deck Stage Illustrating Excavation for Asphalt Waterstop
Figure G2B-3	Typical Fibercrete at Top of Asphalt
Figure G2B-4	Drop Pattern for 6-m-Diameter Shaft Using a 1.2-m-Diameter Tamper
Figure G2B-5	Plan and Section Views of Downward Spin Pattern of Grout Holes
Figure G2B-6	Plan and Section Views of Upward Spin Pattern of Grout Holes

B1. Introduction

This appendix describes construction specifications for placement of shaft seal materials. Flexibility is incorporated in construction specifications to facilitate placement of several different material types. Engineering materials used to seal the full length of the shaft include earthen fill, compacted clay, tamped crushed salt, asphalt, concrete, and a combination of concrete and asphalt in concrete-asphalt waterstops. Appendix A of Permit Attachment G2 provides details of the materials. A full-length shaft seal of this type has never before been constructed; however, application of available technology and equipment, standard construction practices, and common materials provides confidence that the system can be placed to satisfy the design requirements.

A primary feature of the construction specification is development of a work platform from which seal materials are placed. Although the proposed multi-deck stage (galloway) proposed here is engineered specifically for shaft sealing operations, it is similar to stages used for construction of shafts. Inherently flexible, the multi-deck stage facilitates several construction methods required for the various materials specified for the shaft seal system. It provides an assembly of a slickline and header for transport of flowable materials from the surface to the placement horizon. A crane device is attached to the base of the stage to facilitate compaction, and an avenue through the stage provides a means to transport bulk material. It is understood that procedures specified here may change during the tens of years preceding construction as a result of equipment development, additional testing, or design changes. Further, it is acknowledged that the construction methods specified are not the only methods that could place the seal materials successfully.

A few assumptions are made for purposes of evaluating construction activities. These assumptions are not binding, but are included to assist discussion of general operational scenarios. For example, four multi-deck stages are specified, one for each shaft. This specification is based on shaft-sinking experience, which indicates that because of the wear encountered, it is advisable to replace rather than rebuild stages. However, much of the equipment on the multi-deck stage is reused. For scheduling purposes, it is assumed that sealing operations are conducted in two of the four shafts simultaneously. The Air Intake and Exhaust Shafts are sealed first, and the Waste and Salt Handling Shafts are sealed last. With this approach, shaft sealing will require about six and a half years, excluding related work undertaken by the WIPP Management and Operating Contractor (MOC). Sealing the shafts sequentially would require approximately eleven and a half years. To facilitate discussion of scheduling and responsibilities, it is assumed that sealing operations will be conducted by a contractor other than the MOC.

Years from now, when actual construction begins, it is probable that alternatives may be favored. Therefore, construction procedures note alternative methods in recognition that changes are likely and that the construction strategy is sufficiently robust to accommodate alternatives. This appendix contains both general and very specific information. It begins with a discussion of general mobilization in Section 2. Details of the multi-deck construction stage are provided in Section 3. Section 4 contains descriptions of the construction activities. Information presented here is supplemented by several engineering drawings and sketches contained in Permit Attachment G2, Appendix E. The topical information and the level of provided detail substantiate the theory that reliable shaft seal construction is possible using available technology and materials.

B2. Project Mobilization

The duty descriptions that follow are for discussion purposes. The discussions do not presuppose contractual arrangements, but simply identify tasks necessary for shaft seal construction.

B2.1 Subsurface

Prior to initiation of sealing activities, the MOC will remove installations and equipment on the repository level. A determination of items removed will be made before construction begins. Such removal would include, but is not limited to, gates and fences at the shaft; equipment such as winches, ventilation fans, pipelines; and communication and power cables. Additionally, the following items will be removed from the shafts:

- cables, counterweights, and sheaves;
- existing waterlines; and
- electrical cables not required for sealing operations.

The following equipment will be stored near the shaft on the repository level by the Sealing Contractor prior to initiation of sealing activities:

- a concrete header, hopper, and pump;
- a concrete pump line to distribute concrete; and
- an auxiliary mine fan and sufficient flexible ventilation tubing to reach work areas required for installation of the shaft station concrete monolith.

The subsurface will be prepared adequately for placement of the shaft station monolith. Determination of other preparatory requirements may be necessary at the time of construction.

B2.2 Surface

The MOC will remove surface facilities such as headframes, hoists, and buildings to provide clear space for the Sealing Contractor. Utilities required for sealing activities (e.g., air compressors, water, electrical power and communication lines) will be preserved. The Sealing Contractor will establish a site office and facilities required to support the construction crews, including a change house, lamp room, warehouse, maintenance shop, and security provisions. Locations will be selected and foundations constructed for headframes, multi-deck stage winches, man/equipment hoist, and exhaust fan. A drawing in Permit Attachment G2, Appendix E (Sketch E-4) depicts a typical headframe and associated surface facilities. The hoist and winches will be enclosed in suitable buildings; utilities and ventilation ducting will be extended to the shaft collar. The large ventilation fan located near the collar is designed to exhaust air through the rigid ventilation duct, resulting in the movement of fresh air down the shaft. Air flow will be sufficient to support eight workers to the depth of the repository level. The following facilities will be procured and positioned near the shaft collar:

- a concrete batch plant capable of weighing, batching, and mixing the concrete to design specifications;

- a crushing and screening plant to process WIPP salt and local soil;
- an insulated and heated pug mill, asphalt pump, asphalt storage tank, and other auxiliary equipment; and
- pads, silos, and structures to protect sealing materials from the weather.

The Sealing Contractor will construct a temporary structural steel bulkhead over the shaft at the surface. The bulkhead will be sufficiently strong to support the weight of the multi-deck stage, which will be constructed on it. When the multi-deck stage is completed, the headframe will be erected. The headframe (depicted in Permit Attachment G2, Appendix E, Sketch E-3) will be built around the multi-deck stage, and a mobile crane will be required during fabrication. When the headframe is completed, cables for hoisting and lowering the multi-deck stage will be installed. Cables will run from the three winches, over the sheaves in the headframe, down and under the sheaves on the multi-deck stage, and up to anchors in the headframe. The headframe will be sufficiently high to permit the multi-deck stage to be hoisted until the lowest component is 3.05 m (10 ft) above surface. This will facilitate slinging equipment below the multi-deck stage and lowering it to the work surface, as well as activities required at the collar during asphalt emplacement.

The multi-deck stage will be lowered to clear the collar, allowing the installation of compressed-air-activated steel shaft collar doors, which will serve as a safety device, permitting safe access to the man cage and bucket, while preventing objects from falling down the shaft. Following installation of these doors, workers will utilize the multi-deck stage to traverse the shaft from the collar to the repository horizon, inspecting it for safety hazards and making any necessary repairs. After this inspection, the multi-deck stage will return to the surface.

B2.3 Installation of Utilities

In preparation for placement of shaft seal materials, requisite utilities will be outfitted for operations. The multi-deck stage will descend from the collar to the repository horizon. As added assurance against unwanted water, a gathering system similar to the one currently in place at the bottom of the concrete liner will be installed and moved upward as seal emplacement proceeds. Water collected will be hoisted to the surface for disposal. Additionally, any significant inflow will be located and minimized by grouting. After installation of the water gathering system, the following utilities will be installed from surface to the repository horizon by securely fastening them to the shaft wall:

- 5.1-cm steel waterline with automatic shut-off valves every 60 m;
- 10.2-cm steel compressed-air line;
- power, signal, and communications cables;
- 15.2 cm steel slickline and header; and
- a rigid, cylindrical, ventilation duct, which would range from 107 cm in diameter in the three largest shafts to 91 cm in diameter in the Salt Handling Shaft.

B3. Multi-Deck Stage

The multi-deck stage (galloway) provides a work platform from which all sealing operations except placement of asphalt are conducted. The concept of using a multi-deck stage is derived from similar equipment commonly employed during shaft sinking operations. Plan and section views of conceptual multi-deck stages are shown in Permit Attachment G2, Appendix E, Sketches E-1 and E-2. The construction decks specified here are modified from typical shaft sinking configurations in two important ways to facilitate construction. Conceptual illustrations of these two modifications are displayed in Figures G2B-1 and G2B-2. Figure G2B-1 illustrates the multi-deck performing dynamic compaction of salt. Figure G2B-2 illustrates the multi-deck stage configured for excavation of the kerf required for the asphalt waterstop in Salado salt.

A device called a polar crane mounted below the lower deck can be configured for either dynamic compaction or salt excavation. The crane can rotate 360° horizontally by actuating its geared track drive. Its maximum rotational speed will be approximately two revolutions per minute. The crane can be controlled manually or by computer (computerized control will swiftly position the tamper in the numerous drop positions required for dynamic compaction). When excavation for the concrete-asphalt waterstops is required, the tamper, electromagnet, and cable used for dynamic compaction will be removed, and a custom salt undercutter will be mounted on the polar crane trolley. Geared drives on the crane, trolley, and undercutter will supply the force required for excavation. In addition to the special features noted above and shown in Figures G2B-1 and G2B-2, the multi-deck stage has the following equipment and capabilities:

- Maximum hoisting/lowering speed is approximately 4.6 m (15 ft) per minute.
- A cable, electromagnet, and tamper will be attached to the polar crane during dynamic compaction. The cylindrical tamper consists of A-36 carbon steel plates bolted together with high-tensile-strength steel bolts. It is hoisted and dropped by the polar crane using the electromagnet. The tamper will be mechanically secured to the polar crane before personnel are allowed under it.
- Range-finding lasers will facilitate the accurate positioning of the multi-deck stage above the work surface and allow the operator to determine when the surface is sufficiently level. The distance indicated by each laser will be displayed on a monitor at the crane control station.
- Flood lights and remotely controlled closed-circuit television equipment will enable the crane operator to view operations below the multi-deck stage on a monitor.
- Fold-out floor extensions that accommodate the variance in shaft diameter between the unlined and lined portions of the shaft will be provided for safety.
- A cutout in each deck, combined with a removable section of the polar crane track, will permit stage movement without removal of the rigid ventilation duct (which is fastened to the shaft wall).

The multi-deck stage is equipped with many of the features found on conventional shaft sinking stages, such as:

- three independent hoisting/lowering cables,
- man and material conveyances capable of passing through the multi-deck stage and accessing the working surface below,
- a jib crane that can be used to service the working surface below,
- removable safety screens and railings, and
- centering devices.

Three sets of double locking devices are provided to secure the multi-deck stage to the shaft wall. A suitable factor of safety for these locking devices is judged to be 4. The area of the grips securing the deck is calculated from static principles:

$$FS = \mu(Co)(A)/W \quad (B-1)$$

where:

- FS* = factor of safety
μ = steel/salt friction coefficient = 0.15 (see Table 20.1 in McClintock and Aragon, 1966; and Van Sambeek, 1988)
Co = compressive strength of WIPP salt, which varies from 172 kg/cm² to 262 kg/cm² (Van Sambeek, 1988)
W = total vertical weight
A = total gripper pad surface area.

Manipulating the equation to solve for required area, applying a factor of safety of 4, selecting the heaviest work stage (753,832 kg) and the minimum compressive strength value for salt (assuming that the locking pressure equals the minimum compressive strength of salt), the following gripper surface area (*A*) is:

$$A = 4(753,832 \text{ kg})/0.15(172 \text{ kg/cm}^2) = 11,416.5 \text{ cm}^2, \text{ and each of the six gripper pads would be } 1902.8 \text{ cm}^2.$$

As designed, each gripper pad area is 2167.2 cm², resulting in a factor of safety (*FS*) of 4.56. Additionally, although tension in the hoisting cables is relaxed while the multi-deck stage is in the locked configuration, the cables are still available to hold the work-deck, should the locking devices fail.

B4. Placement of Sealing Materials

Construction activities include placement of materials in three basic ways: (1) by slickline (e.g., concrete and asphalt), (2) by compaction (e.g., salt and earthen fill), and (3) by physical placement (e.g., clay blocks). Materials will be placed at various elevations using identical procedures. Because placement procedures generally are identical regardless of elevation, they

will be described only once. Where differences occur, they will be identified and described. In general, placement of shaft seal elements is described from bottom to top.

B4.1 Concrete

Concrete is used as a seal material for several different components, such as the existing sumps in the Salt Handling Shaft and the Waste Shaft, the shaft station monoliths, concrete plugs, and concrete-asphalt waterstops. Existing sumps are shown in Permit Attachment G2, Appendix E, Drawings SNL-007, Sheets 6 and 21. Shaft station monoliths are shown in Drawings SNL-007, Sheets 6, 11, 16, and 21. Concrete plugs are depicted on Drawings SNL-007, Sheets 4, 5, 9, 10, 14, 15, 19, and 20. Lower, middle, and upper concrete-asphalt waterstops are shown in Drawing SNL-007, Sheet 22. Construction material for all concrete members will be Salado Mass Concrete (SMC).

As specified, all SMC will be mixed on surface to produce a product possessing the characteristics defined in Permit Attachment G2, Appendix A. Concrete will be transferred to its placement location within the shaft via slickline and header. The slickline (shown in Figure G2B-1) is a steel pipe fastened to the shaft wall. Vertical drops as great as 656 m to the repository horizon are required. Such concrete transport and construction are common in mining applications. For example, a large copper mine in Arizona is placing concrete at a depth of 797 m using this procedure. A header attached to the bottom of the slickline is designed to absorb kinetic energy generated by the falling material. The header, a steel pipe slightly larger in diameter than the slickline and made of thicker steel, diverts the flow 45°, absorbing most of the impact. Because the drop generates considerable force, the header will be securely supported by a reinforced steel shelf bolted to the shaft wall. A flexible hose, in sections approximately 3 m long and joined by quick-connect fittings, will be attached to the header.

B4.1.1 Shaft Station Monolith

Construction of the shaft station monoliths is preceded by filling two existing sumps with SMC. Initially, sufficient hose will be used to convey the concrete to the bottom of the sump. The discharge will remain below the concrete surface during placement to minimize air entrainment. Sections of hose will be withdrawn and removed as the SMC rises to the floor of the repository horizon in a continuous pour. Subsequent to filling the sump, arrangements will be made to place the concrete monolith.

A small mine fan will be located above the rigid suction-duct inlet to ensure a fresh air base. Masonry block forms will be constructed at the extremities of the shaft station monolith in the drifts leading from the station. Temporary forms, partially filling the opening, will be erected at the shafts to facilitate the placement of the outermost concrete. These temporary forms will permit access necessary to ensure adequate concrete placement. SMC will be transported via the slickline to the header, which will discharge into a hopper feeding the concrete pump, and the pump will be attached to the pumpcrete line. The pumpcrete line, suspended in cable slings near the back of the drifts, will be extended to the outer forms. A flexible hose, attached to the end of the pumpcrete line, will be used by workers to direct emplacement. The pumpcrete line will be withdrawn as emplacement proceeds toward the shaft.

When the concrete has reached the top of the temporary forms, they will be extended to seal the openings completely, and two 5-cm-diameter polyvinyl chloride (PVC) pipes will be incorporated in the upper portion of each form. Both pipes will be situated in a vertical plane

oriented on the long axis of the heading and inclined away from the station at approximately 70° to the horizontal. The upper end of the top pipe will extend to just below the back, and the upper end of the lower pipe will be located just below that of the top pipe. SMC will be injected through the lower pipe until return is obtained from the upper pipe, ensuring that the heading has been filled to the back. The header will then be moved to a position in the shaft above the designed elevation at the top of the shaft station monolith and supported by a bracket bolted to the shaft wall. After the outer concrete has achieved stability, the temporary interior forms may be removed. Equipment no longer required will be slung below the multi-deck stage and hoisted to surface for storage and later use. The station and shaft will be filled to design elevation with concrete via the slickline, header, and flexible hose. The slickline is cleaned with spherical, neoprene swabs ("pigs") that are pumped through the slickline, header, and hose.

B4.1.2 Concrete-Asphalt Waterstops

Lower, middle, and upper concrete-asphalt waterstops in a given shaft are identical and consist of two SMC sections separated by an asphalt waterstop. Before the bottom member of the lower concrete component is placed, the multi-deck stage will be raised into the headframe; the polar crane will be mounted below the lower deck; and the salt undercutter will be mounted on the crane trolley. The multi-deck stage will then return to the elevation of the concrete component. Two undercutter bars will be used to make the necessary excavations for upper, middle, and lower asphalt-concrete waterstops and the concrete plug above the Salado Formation. Notches for the plugs will be excavated using a short, rigid cutter bar (length less than half the radius). The kerf for the asphalt waterstop will be excavated using a long cutter bar that can excavate the walls to a depth of one shaft radius. These operations will be conducted as required as seal placement proceeds upward.

The lower concrete member (and all subsequent concrete entities) will be placed via the slickline, header, and flexible hose, using the procedure outlined for the shaft station monolith. Construction of vertical shaft seals provides the ideal situation for minimizing interface permeability between the rock and seal materials. Concrete will flow under its own weight to provide intimate contact. A tight cohesive interface was demonstrated for concrete in the small-scale seal performance tests (SSSPTs). The SSSPT concrete plugs were nearly impermeable without grouting. However, interface grouting is usually performed in similar construction, and it will be done here in the appropriate locations.

B4.1.3 Concrete Plugs

An SMC plug, keyed into the shaft wall, is situated a few meters above the upper Salado contact in the Rustler Formation. A final SMC plug is located a few meters below surface in the Dewey Lake Redbeds. This plug is emplaced within the existing shaft liner using the same construction technique employed for the concrete-asphalt waterstops.

B4.2 Clay

B4.2.1 Salado and Rustler Compacted Clay Column

Blocks of sodium bentonite clay, precompacted to a density of 1.8 to 2.0 g/cm³, will be the sealing material. This density has been achieved at the WIPP using a compaction pressure of 492.2 kg/cm² in a machine designed to produce adobe blocks (Knowles and Howard, 1996). Blocks are envisioned as cubes, 20.8 cm on the edge, weighing approximately 18 kg, a

reasonable weight for workers to handle. The bentonite blocks will be compacted at the WIPP in a new custom block-compacting machine and will be stored in controlled humidity to prevent desiccation cracking. Blocks will be transported from surface in the man cage, which will be sized to fit through the circular "bucket hole" in the multi-deck stage. The conveyance will be stacked with blocks to a height of approximately 1.8 m.

Installation will consist of manually stacking individual blocks so that all interfaces are in contact. Block surfaces will be moistened with a spray of potable water as the blocks are placed to initiate a minor amount of swelling, which will ensure a tight fit and a decrease in permeability. Peripheral blocks will be trimmed to fit irregularities in the shaft wall and placed as close to the wall as possible. Trimmed material will be manually removed with a vacuum. Dry bentonite will be manually tamped into remaining voids in each layer of blocks. This procedure will be repeated throughout the clay column. The multi-deck stage will, in all cases, be raised and utilities removed to the surface as emplacement of sealing materials proceeds upward.

Dynamic compaction construction is an alternative method of clay emplacement that could be considered in the detailed design. Dynamic compaction materials being considered are:

- sodium bentonite/fine silica sand, and
- highly compressed bentonite pellets.

Boonsinsuk et al. (1991) developed and tested a dynamic (drop hammer) method for a relatively large diameter (0.5-m) hole, simulated with a steel cylinder, that gave very good results on 1 : 1 dry mass mixtures of sodium bentonite and sand, at a moisture content of 17% to 19%. The alternatives have the advantages of simplifying emplacement.

B4.3 Asphalt

Asphalt, produced as a distillate of petroleum, is selected as the seal material because of its longevity, extremely low permeability, history of successful use as a shaft lining material, and its ability to heal if deformed. Shielded from ultraviolet radiation and mixed with hydrated lime to inhibit microbial degradation, the longevity of the asphalt will be great. Emplaced by tremie line at the temperature specified, the material will be fluid and self-leveling, ensuring complete contact with the salt.

Construction of an asphalt column using heated asphalt will introduce heat to the surrounding salt. The thermal shock and heat dissipation through the salt has not been studied in detail. Performance of the asphalt column may be enhanced by the introduction of the heat that results from acceleration of creep and healing of microfractures. If, upon further study, the thermomechanical effects are deemed undesirable or if an alternative construction method is preferred at a later date, asphalt can readily be placed as blocks. Asphalt can "cold flow" to fill gaps, or the seams between blocks can be filled with low-viscosity material.

B4.3.1 Concrete-Asphalt Waterstops

Electrically insulated, steel grating flooring will be constructed over the shaft at the surface. A second, similar flooring will be built in the shaft 3 m below the first. These floors will be used only during the emplacement of asphalt and asphaltic mastic mix (AMM) and will be removed at all other times. A 12.7-cm ID/14-cm OD, 4130 steel pipe (tremie line) in 3-m lengths will be electrically equipped for impedance heating, then insulated and suspended in the shaft from

slips (pipe holding devices) situated on the upper floor. The tremie line cross-sectional area is smallest at the shoulder of the top thread, where tensional yield is 50,000 kg; the line weight is 20.8 kg/m. Heavier weights are routinely suspended in this manner in the petroleum and mining industries.

Neat, AR-4000-graded petroleum-based asphalt cement will be the sealing material for asphalt waterstops. Neat asphalt from the refinery will be delivered to the WIPP at approximately 80°C in conventional, insulated refinery trucks and pumped into a heated and insulated storage tank located near the shaft. The multi-deck stage will be hoisted into the headframe and mechanically secured for safety. Asphalt, heated to 180°C ±5°, will be pumped down the shaft to the fill elevation through the heated tremie line. Viscosity of the neat asphalt for the waterstops will be sufficiently low to allow limited penetration of the DRZ. Installation of asphalt in each of the concrete-waterstops is identical.

As the pipe is lowered, workers on the lower deck will attach the wiring required for heating circuits and apply insulation. Workers on the top deck will install flanged and electrically insulated couplings as required (the opening in the slip bowl will be large enough to permit the passage of these couplings). Properly equipping and lowering the pipe should progress at the rate of one section every 10 minutes. The lower asphalt waterstop requires approximately 607 m of pipe for a casing weight of 12,700 kg. Additionally, electrical wire and insulation will weigh about 7250 kg for a total equipped tremie line weight of 20,000 kg. Therefore, the safety factor for the tremie line is 50,000 kg/20,000 kg, or 2.5.

To minimize air entrainment, the lower end of the tremie line will be immersed as much as 1 m during hot asphalt emplacement. Therefore, the lower 3 m of casing will be left bare (to simplify cleaning when emplacement has been completed).

Initially the tremie line will be lowered until it contacts the concrete plug (immediately underlying the excavation for the waterstop) and then raised approximately 0.3 m. Asphalt emplacement will proceed as follows:

- The impedance heating system will be energized, heating the tremie line to 180°C ±5°, and the asphalt in the storage tank will be heated to approximately 180°C ±5°.
- Heated, neat asphalt will be pumped down the tremie line at a rate approximating 13 L/min. This low rate will ensure that the asphalt flows across the plug from the insertion point, completely filling the excavation and shaft to the design elevation.
- The tremie line will be raised 3 m and cleaned by pumping a neoprene swab through it with air pressure. Impedance heating will be stopped, and the line will be allowed to cool. When cool, the line will be hoisted, stripped, cleaned, disassembled, and stored for future use.

Sealing operations will be suspended until the air temperature at the top of the asphalt has fallen to approximately 50°C for the comfort of the workers when they resume activity at the fill horizon. Temperature will be determined by lowering a remotely read thermometer to an elevation approximately 3 m above the asphalt at the center of the shaft. The temperature of the asphalt at the center of the shaft will be 50°C in about a month, but active ventilation should permit work to resume in about two weeks (see calculations in Appendix D of *Waste Isolation*

Pilot Plant Shaft Sealing System Compliance Submittal Design Report ("Compliance Submittal Design Report") (Sandia, 1996)).

When sufficient cooling has occurred, workers will descend in the multi-deck stage and cover the hot asphalt with an insulating and structural material such as fiber-reinforced shotcrete, as illustrated in Figure G2B-3. To accomplish this, they will spray cementitious shotcrete containing fibrillated polypropylene fibers (for added tensional strength), attaining a minimum thickness of approximately 0.6 m.

B4.3.2 Asphaltic Mastic Mix Column

Asphaltic mastic mix (AMM) for the column will be prepared on surface in a pug mill. Viscosity of the AMM can be tailored to provide desired properties such as limited migration into large fractures.

- AMM will be prepared by mixing the ingredients in the pug mill, which has been heated to $180^{\circ}\text{C} \pm 5^{\circ}$. The mix will be pumped from the pug mill through the tremie line to the emplacement depth. AMM is self-leveling at this temperature, and its hydrostatic head will ensure intimate contact with the shaft walls.
- Pumping rate will be approximately 200 L/min for efficiency, because of the larger volume (approximately 1,224,700 L in the Air Intake Shaft). To facilitate efficient emplacement and avoid air entrainment, the tremie line will not be shortened until the mix has filled 6 vertical meters of the shaft. Back pressure (approximately 0.84 kg/cm^2) resulting from 6 m of AMM above the discharge point will be easily overcome from surface by the hydraulic head.

After 6 vertical meters of AMM have been placed:

- Impedance heating current will be turned off and locked out (the hot line will drain completely).
- To prevent excessive back pressure resulting from AMM above the insertion point, the line will be disconnected from the pump and hoisted hot. Two sections will be stripped, removed, cleaned with a "pig," and stacked near the shaft.
- Electrical feed will be adjusted (because of the decreased resistance of the shortened line).
- The tremie line will be reconnected to the pump.
- The impedance heating system will be energized.
- When the temperature of the line has stabilized at $180^{\circ}\text{C} \pm 5^{\circ}$, pumping will resume.

This procedure will be followed until the entire column, including the volume computed to counteract 0.9 m of vertical shrinkage (calculations in Appendix D of the Compliance Submittal Design Report (Sandia, 1996)), has been placed. The line will be disconnected from the pump and cleaned by pumping "pigs" through it with air pressure. It will then be hoisted, stripped, removed in 3-m sections, and stacked on surface for reuse.

Sealing operations will be suspended following removal of the tremie line, and ventilation will be continuous to speed cooling. The column will shrink vertically but maintain contact with the shaft walls as it cools. When the air temperature at 3 m above the asphalt has cooled sufficiently, workers will descend on the multi-deck stage and cover the hot asphalt with fibercrete as described for the concrete-asphalt waterstop (Permit Attachment G2, Appendix B, Section B4.3.1) and illustrated in Figure G2B-3.

Note: Near the top of the Salado Formation, portions of the concrete liner key, chemical seal rings, and concrete and steel shaft liners will be removed. Liner removal will occur before emplacement of AMM. For safety, exposed rock will be secured with horizontal, radial rock bolts and cyclone steel mesh. A range-finding device, fastened to the shaft wall approximately 3 m above the proposed top of the asphaltic column, will indicate when the hot AMM reaches the desired elevation. A remotely read thermometer, affixed to the shaft wall approximately 2 m above the proposed top of the column, will show when the air temperature has fallen sufficiently to resume operations. The intake of the rigid ventilation duct will be positioned approximately 3 m above the proposed top of the column, and ventilation will be continuous throughout emplacement and cooling of the asphaltic column. After the multi-deck stage has been hoisted into the headframe and mechanically secured for safety, emplacement of AMM will proceed.

B4.4 Compacted Salt Column

Crushed, mine-run salt, dynamically compacted against intact Salado salt, is the major long-term shaft seal element. As-mined WIPP salt will be crushed and screened to a maximum particle dimension of 5 mm. The salt will be transferred from surface to the fill elevation via the slickline and header. A flexible hose attached to the header will be used to emplace the salt, and a calculated weight of water will be added. After the salt has been nominally leveled, it will be dynamically compacted. Dynamic compaction consists of compacting material by dropping a tamper on it and delivering a specified amount of energy. The application of three times Modified Procter Energy (MPE) to each lift (one MPE equals 2,700,000 Joules/m³) will result in compacting the salt to 90% of the density of in-place rock salt.

Approximately 170 vertical meters of salt will be dynamically compacted. Dynamic compaction was validated in a large-scale demonstration at Sandia National Laboratories during 1995. As-mined WIPP salt was dynamically compacted to 90% density of in-place rock salt in a cylindrical steel chamber simulating the Salt Handling Shaft (Ahrens and Hansen, 1995). Depth of compaction is greater than that achieved by most other methods, allowing the emplacement of thicker lifts. For example, dropping the 4.69 metric ton tamper 18 m (as specified below) results in a compaction depth of approximately 4.6 m, allowing emplacement of lifts 1.5-m high. Most other compaction methods are limited to lifts of 0.3 m or less. Lift thickness will be increased and drop height decreased for the initial lift above the concrete plug at the base of the salt column to ensure that the concrete is not damaged. Drop height for the second and third lifts will be decreased as well. Although the tamper impact is thereby reduced, three MPE will be delivered to the entire salt column.

If lifts are 1.5-m thick, the third lift below the surface will receive additional densification during compaction of overlying lifts, and this phenomenon will proceed up the shaft. Construction will begin by hoisting the multi-deck stage to the surface and attaching the cable, electromagnet, and tamper to the hoist on the polar crane. The multi-deck assembly will be lowered to the placement elevation, and moisture content of the crushed and screened salt will be calibrated. Then the salt will be conveyed at a measured rate via a weighbelt conveyor to a vibrator-

equipped hopper overlying the 15.2-cm ID slickline. The salt will pass down the slickline and exit a flexible hose connected to the header. A worker will direct the discharge so that the upper surface of the lift is nominally level and suitable for dynamic compaction. A second worker will add potable water, in the form of a fine spray, to the salt as it exits the hose. Water volume will be electronically controlled and coordinated with the weight of the salt to achieve the desired moisture content.

The initial lift above the SMC will be 4.6 m, and drop height will be 6 m. This increased lift thickness and reduced drop height are specified to protect the underlying SMC plug from damage and/or displacement from tamper impact. Compaction depth for a drop height of 6 m is approximately 3.7 m. Ultimately, the tamper will be dropped six times in each position, resulting in a total of 132 drops per lift in the larger shafts. The drop pattern is shown in Figure G2B-4. A salt lift 1.5 m high will then be placed and leveled. Following compaction of the initial lift, the multi-deck stage will be positioned so the base of the hoisted tamper is 10 m above the surface of the salt.

The multi-deck stage will then be secured to the shaft walls by activating hydraulically powered locking devices. Hydraulic pressure will be maintained on these units when they are in the locked position; in addition, a mechanical pawl and ratchet on each pair will prevent loosening. The safety factor for the locking devices has been calculated to be approximately 4.5. After locking, tension in the hoisting cables will be relaxed, and centering rams will be activated to level the decks. Prior to positioning the stage, tension will be applied to the hoisting cables; the centering rams will be retracted; and the locking devices will be disengaged.

The work deck will be hoisted until the base of the retracted tamper is 23 m above the surface of the salt, where it will be locked into position and leveled as described above. This procedure, repeated throughout the salt column, allows emplacement and compaction of three lifts (1.5-m thick) per multi-deck stage move. Depth of compaction for a drop height of 18 m is approximately 4.6 m. Therefore the third lift below the fill surface will receive a total of 9 MPE (274,560 m kg/m³), matching the energy applied in the successful, large-scale demonstration.

The compactive effect expands laterally as it proceeds downward from the base of the tamper and will effectively compact the salt into irregularities in the shaft wall, as demonstrated in the large-scale demonstration. Although other techniques could be used, dynamic compaction was selected because it is simple, can be used in the WIPP shafts, and has been demonstrated (Hansen and Ahrens, 1996).

The tamper will be dropped from the hoisted position by turning off the power to the electromagnet. Immediately upon release, the crane operator will "chase" the tamper by lowering the electromagnet at twice hoisting speed; the magnet will engage the tamper, allowing it to be hoisted for the subsequent drop. Initially, the tamper will be dropped in positions that avoid impact craters caused by preceding drops. The surface will then be leveled manually and the tamper dropped in positions omitted during the previous drop series.

Experience gained during the large-scale salt compaction demonstration indicated that a considerable volume of dust is generated during the emplacement of the salt, but not during dynamic compaction. However, because the intake of the rigid vent duct is below the multi-deck stage, workers below the stage will wear respirators during emplacement. They will be the only workers affected by dust during dynamic compaction.

The Air Intake Shaft will require 22 drop positions (Figure G2B-4). Application of one MPE requires six drops in each position, for a total of 132 drops per lift. Three MPE, a total of 396 drops per lift, will be applied to all salt. After each compaction cycle, the salt surface will be leveled manually and the tamper will be dropped in positions omitted in the preceding drop series. Two lifts, each 1.8 m high, will then be sequentially placed, leveled, and compacted with two MPE, using a 6-m drop height.

Dynamic compaction ensures a tight interface. Salt compacted during the large-scale dynamic compaction demonstration adhered so tenaciously to the smooth interior walls of the steel compaction chamber that grinders with stiff wire wheels were required for its removal.

B4.5 Grout

Ultrafine sulfate-resistant cementitious grout (Ahrens et al., 1996) is selected as the sealing material. Specifically developed for use at the WIPP, and successfully demonstrated in an in situ test, the hardened grout has a permeability of 1×10^{-21} m². It has the ability to penetrate fractures smaller than 6 microns and is being used for the following purposes:

- to seal many of the microfractures in the DRZ and ensure a tight interface between SMC and the enclosing rock, and
- to solidify fractured rock behind existing concrete shaft liners, prior to removal of the liner (for worker safety).

The interface between concrete plugs in the Salado Formation (and one in the Rustler Formation, a short distance above the Salado) will be grouted. A 45° downward-opening cone of reverse circulation diamond drill holes will be collared in the top of the plugs, drilled in a spin pattern (see Figure G2B-5), and stage grouted with ultrafine cementitious grout at 3.5 kg/cm² below lithostatic pressure. Stage grouting consists of:

- drilling and grouting primary holes, one at a time;
- drilling and grouting secondary holes, one at a time, on either side of the primary holes that accepted grout; and
- (if necessary) drilling and grouting tertiary holes on either side of secondary holes that accepted grout.

Note: For safety, all liner removal tasks will be accomplished from the bottom deck. In areas where the steel liner is removed, it will be cut into manageable pieces with a cutting torch and hoisted to the surface for disposal. Mechanical methods will be employed to clean and roughen the existing concrete shaft liner before placing the Dewey Lake SMC plug in the shafts.

The work sequence will start 3 m below the lower elevation of liner removal. A 45° upward-opening cone of grout injection holes, drilled in a "spin" pattern (Figure G2B-6), will be drilled to a depth subtending one shaft radius on a horizontal plane. These holes will be stage grouted as described in Section 4.5. Noncoring, reverse circulation, diamond drill equipment will be used to avoid plugging fractures with fine-grained diamond drill cuttings. Ultrafine cementitious grout will be mixed on the surface, transferred via the slickline to the upper deck of the multi-deck stage, and injected at 3.5 kg/cm² gage below lithostatic pressure to avoid hydrofracturing the rock.

Grout will be transferred in batches, and after each transfer, a "pig" will be pumped through the slickline and header to clean them. Grouting will proceed upward from the lowest fan to the highest. Recent studies conducted in the Air Intake Shaft (Dale and Hurtado, 1996) show that this hole depth exceeds that required for complete penetration of the Disturbed Rock Zone (DRZ). Maximum horizontal spacing at the ends of the holes will be 3 m.

The multi-deck stage will then be raised 3 m and a second fan, identical to the first, will be drilled and grouted. This procedure will continue, with grout fans 3 m apart vertically, until the highest fan, located 3 m above the highest point of liner removal, has been drilled and grouted. Ultrafine cementitious grout was observed to penetrate more than 2 m in the underground grouting experiment conducted at the WIPP in Room L-3 (Ahrens and Onofrei, 1996).

When grouting is completed, the multi-deck stage will be lowered to the bottom of the liner removal section and a hole will be made through the concrete liner. This hole, approximately 30 cm in diameter, will serve as "free-face" to which the liner will be broken. Similar establishment and utilization of free face is a common practice in hard rock mining (e.g., the central drill hole in a series drilled into the rock to be blasted is left empty and used as free-face to which explosives in adjacent holes break the rock). Radial, horizontal percussion holes will be drilled on a 30-cm grid (or less, if required), covering the liner to be removed. Hydraulic wedges, activated in these holes, will then break out the liner, starting adjacent to the free face and progressing away from it, from the bottom up. Broken fragments of the concrete liner will fall to the fill surface below.

A mucking "claw," suspended from the trolley of the polar crane, will collect the broken concrete and place it in the bucket for removal to the surface. As many as three buckets can be used to speed this work.

B4.6 Compacted Earthen Fill

Local soil, screened to a maximum particle dimension of 13 mm, will be placed and compacted to inhibit the migration of surficial water into the shaft cross section. Such movement is further decreased by a 12-m high SMC plug at the top of the Dewey Lake Redbeds.

B4.6.1 Lower Section

Emplacement of the compacted earthen fill will proceed as follows:

- Moisture content of the screened soil will be determined.
- The soil will then be transferred via the slickline, header, and flexible hose from surface to the fill elevation. The moisture content optimal for compaction will be achieved using the same procedure as described for compacted salt (Permit Attachment G2, Appendix B, Section B4.4). The soil will be emplaced in lifts 1.2 m high (depth of compaction is approximately 3.7 m) and dynamically compacted using a drop height of 18.3 m.
- The fill will be dynamically compacted until its hydraulic conductivity to water is nominally equivalent to that of the surrounding formation.

This procedure will continue until the lower section has been emplaced and compacted. Care will be exercised at the top of the column to ensure that all soil receives sufficient compaction.

B4.6.2 Upper Section

The upper section contains insufficient room to employ dynamic compaction. Therefore the screened soil, emplaced as described above, will be compacted by vibratory-impact sheepsfoot roller, vibratory sheepsfoot roller, or a walk-behind vibratory-plate compactor. Because of the limited compaction depth of this equipment, lifts will be 0.3 m high. The top of the fill will be coordinated with the MOC to accommodate plans for decommissioning surface facilities and placing markers.

B4.7 Schedule







Preliminary construction schedules are included on the following pages. The first schedule is a concise outline of the total construction schedule. It is followed by individual schedules for each shaft. The first schedule in each shaft series is a truncated schedule showing the major milestones. The truncated schedules are followed by detailed construction schedules for each shaft. These schedules indicate that it will take approximately six and a half years to complete the shaft sealing operations, assuming two shafts are simultaneously sealed.

Waste Isolation Pilot Plant
Hazardous Waste Facility Permit
Attachment G2, Appendix G2-B
October 2023

SEALING SCHEDULE - ALL SHAFTS

SEALING SCHEDULE - AIR INTAKE SHAFT

ID	Task Name	Duration	Year 1				Year 2				Year 3			
			Qtr 1	Qtr 2	Qtr 3	Qtr 4	Qtr 1	Qtr 2	Qtr 3	Qtr 4	Qtr 1	Qtr 2	Qtr 3	Qtr 4
1	Mobilization	4w	■											
3	Plant Set-up	12w	■	■										
5	Inspect & Scale Shaft-2151'	1w		■										
7	Install Construction Utilities	7.17w		■										
9	Drill & Grout Lining	11.5w			■									
11	Shaft Station Monolith-37'	4.78w			■									
15	Lower Salado Compacted Clay Column-93.5'	4.96w				■								
17	Lower Concrete-Asphalt Waterstop-50'	8.25w				■								
26	Compacted Salt Column-563.5'	23.58w					■							
28	Middle Concrete-Asphalt Waterstop-50'	8.25w					■							
37	Upper Salado Compacted Clay Column-344'	18.24w						■						
39	Upper Concrete-Asphalt Waterstop-50'	10.25w						■						
48	Asphalt Column-138.3'	19.41w							■					
56	Concrete Plug-20'	5.99w								■				
61	Remove Concrete Shaft Lining	5.71w									■			
63	Rustler Compacted Clay Column-234.7'	8.36w										■		
65	Compacted Earthen Fill-473'	7.59w											■	
67	Concrete Plug-40'	2.98w												■
71	Compacted Earthen Fill-57'	0.65w												■
73	Demobilization	3.2w												■

Project: AIR INTAKE SHAFT SEALING SCHEDULE Date: Tue 7/9/96	Task  Summary  Rolled Up Progress  Progress  Rolled Up Task  Milestone  Rolled Up Milestone 
---	---

ID	Task Name	Duration	Year 1				Year 2				Year 3			
			Qtr 1	Qtr 2	Qtr 3	Qtr 4	Qtr 1	Qtr 2	Qtr 3	Qtr 4	Qtr 1	Qtr 2	Qtr 3	Qtr 4
1	Mobilization	4w	█											
2	Mobilize	4w		█										
3	Plant Set-up	12w	█	█	█									
4	Plant Set-up	12w	█	█	█									
5	Inspect & Scale Shaft-2151'	1w												
6	Inspect & Scale Shaft	1w												
7	Install Construction Utilities	7.17w		█										
8	Install Utilities	7.17w		█										
9	Drill & Grout Lining	11.5w			█	█								
10	Drill & Grout Lining	11.5w			█	█								
11	Shaft Station Monolith-37'	4.78w					█							
12	Construct Bulkheads	0.8w						█						
13	Pour Concrete (37' high)	0.98w							█					
14	Cure Concrete	3w								█				
15	Lower Salado Compacted Clay Column-93.5'	4.98w									█			
16	Emlace Bentonite Blocks (93.5' high)	4.98w										█		
17	Lower Concrete-Asphalt Waterstop-50'	8.25w											█	
18	Excavate for Lower Plug	1.67w												█
19	Pour Concrete-Lower Plug (23' high typ.)	0.28w												█
20	Excavate Waterstop	0.63w												█
21	Place Asphalt (4' high typ.)	0.72w												█
22	Cool-down Asphalt	1w												█







Project: AIR INTAKE SHAFT SEALING SCHEDULE Date: Tue 7/9/96	Task Summary Progress Rolled Up Task Milestone Rolled Up Milestone	Rolled Up Progress
---	--	---

Page 1

ID	Task Name	Duration	Year 1				Year 2				Year 3			
			Qtr 1	Qtr 2	Qtr 3	Qtr 4	Qtr 1	Qtr 2	Qtr 3	Qtr 4	Qtr 1	Qtr 2	Qtr 3	Qtr 4
23	Excavate for Upper Plug	1.67w												
24	Pour Concrete-Upper Plug (23' high typ.)	0.26w												
25	Cure Concrete	2w												
26	Compacted Salt Column-563.5'	23.56w												
27	Emlace & Compact Crushed/Screened Salt	23.56w												
28	Middle Concrete-Asphalt Waterstop-50'	8.25w												
29	Excavate for Lower Plug	1.67w												
30	Pour Concrete-Lower Plug	0.26w												
31	Excavate Waterstop	0.63w												
32	Place Asphalt	0.72w												
33	Cool-down Asphalt	1w												
34	Excavate for Upper Plug	1.67w												
35	Pour Concrete-Upper Plug	0.26w												
36	Cure Concrete	2w												
37	Upper Salado Compacted Clay Column-344'	18.24w												
38	Emlace Bentonite Blocks	18.24w												
39	Upper Concrete-Asphalt Waterstop-50'	10.25w												
40	Excavate for Lower Plug	1.67w												
41	Pour Concrete-Lower Plug	0.26w												
42	Excavate Waterstop	0.63w												
43	Place Asphalt	0.72w												
44	Cool-down Asphalt	1w												

Project: AIR INTAKE SHAFT SEALING SCHEDULE Date: Tue 7/9/96	Task		Summary		Rolled Up Progress	
	Progress		Rolled Up Task			
	Milestone		Rolled Up Milestone			

ID	Task Name	Duration	Year 1				Year 2				Year 3			
			Qtr 1	Qtr 2	Qtr 3	Qtr 4	Qtr 1	Qtr 2	Qtr 3	Qtr 4	Qtr 1	Qtr 2	Qtr 3	Qtr 4
45	Excavate for Upper Plug	1.67w												
46	Pour Concrete-Upper Plug	0.28w												
47	Cure Concrete	4w												
48	Asphalt Column-138.3'	19.41w												
49	Remove Lining in Key	3.76w												
50	Remove Chemical Seal Rings	0.6w												
51	Mobilize to Emplace Asphalt	0.3w												
52	Asphalt in Salt Section	3.62w												
53	Asphalt in Lower Lined Section	1.93w												
54	Complete Asphalt Emplacement	2.77w												
55	Cool-down Asphalt	6.43w												
56	Concrete Plug-20'	5.99w												
57	Remove Concrete Lining & Rock	1.65w												
58	Remove Liner Plate	0.13w												
59	Pour Concrete(20' high)	0.21w												
60	Cure Concrete	4w												
61	Remove Concrete Shaft Lining	5.71w												
62	Remove 86' of lining-4 zones	5.71w												
63	Rustler Compacted Clay Column-234.7'	8.36w												
64	Emplace & Compact Bentonite(234.7' high)	8.36w												
65	Compacted Earthen Fill-473'	7.59w												
66	Emplace & Compact Earthen Fill(473' high)	7.59w												

Project: AIR INTAKE SHAFT SEALING SCHEDULE Date: Tue 7/9/96	Task  Summary  Rolled Up Progress  Progress  Rolled Up Task  Milestone  Rolled Up Milestone 
---	--

Page 3





ID	Task Name	Duration	Year 1				Year 2				Year 3			
			Qtr 1	Qtr 2	Qtr 3	Qtr 4	Qtr 1	Qtr 2	Qtr 3	Qtr 4	Qtr 1	Qtr 2	Qtr 3	Qtr 4
67	Concrete Plug-40'	2.96w												
68	Clean Existing Surface	0.6w												
69	Pour Concrete(40' high)	0.36w												
70	Cure Concrete	2w												
71	Compacted Earthen Fill-57'	0.65w												
72	Emlace & Compact Earthen Fill (57' high)	0.65w												
73	Demobilization	3.2w												
74	Demob	3.2w												

Project: AIR INTAKE SHAFT SEALING SCHEDULE Date: Tue 7/9/96	Task	Summary	Rolled Up Progress
	Progress	Rolled Up Task	
	Milestone	Rolled Up Milestone	◇

14

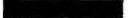
SEALING SCHEDULE - SALT HANDLING SHAFT

ID	Task Name	Duration	Year 1				Year 2				Qtr 1	
			Qtr 1	Qtr 2	Qtr 3	Qtr 4	Qtr 1	Qtr 2	Qtr 3	Qtr 4		
1	Mobilization	4w	■									
3	Plant Set-up	12w	■	■								
5	Inspect & Scale Shaft-2164.5'	1.06w		■								
7	Install Construction Utilities	7.6w		■	■							
9	Drill & Grout Lining	5.35w			■							
12	Shaft Station Monolith-37'	4.44w			■							
16	Lower Salado Compacted Clay Column-107'	3.06w				■						
18	Lower Concrete-Asphalt Waterstop-50'	8.74w				■	■					
27	Compacted Salt Column-550'	12.67w					■	■				
29	Middle Concrete-Asphalt Waterstop-50'	6.74w						■	■			
38	Upper Salado Compacted Clay Column-335'	9.58w						■	■			
40	Upper Concrete-Asphalt Waterstop-50'	8.74w							■	■		
49	Asphalt Column-140'	15.33w								■	■	
57	Concrete Plug-20'	5.32w									■	■
61	Remove Concrete Shaft Lining	1.9w										■
63	Rustler Compacted Clay Column-234'	4.81w										■
65	Compacted Earthen Fill-449'	3.65w										■
67	Concrete Plug-40'	2.45w										■
71	Compacted Earthen Fill-92.5'	0.65w										■
73	Demobilization	3w										■

Project: SALT HANDLING SHAFT SEALING SCHEDULE Date: Tue 7/9/96	Task  Summary  Rolled Up Progress  Progress  Rolled Up Task Milestone  Rolled Up Milestone
---	---

ID	Task Name	Duration	Year 1				Year 2							
			Qtr 1	Qtr 2	Qtr 3	Qtr 4	Qtr 1	Qtr 2	Qtr 3	Qtr 4	Qtr 1			
1	Mobilization	4w	■											
2	Mobilize	4w	■											
3	Plant Set-up	12w	■	■										
4	Plant Set-up	12w	■	■										
5	Inspect & Scale Shaft-2164.5'	1.06w		■										
6	Inspect & Scale Shaft	1.06w		■										
7	Install Construction Utilities	7.6w		■										
8	Install Utilities	7.6w		■										
9	Drill & Grout Lining	5.35w			■									
10	Drill Grout Holes	2.14w			■									
11	Grout Lining	3.21w			■									
12	Shaft Station Monolith-37'	4.44w			■									
13	Construct Bulkheads	0.8w			■									
14	Pour Concrete (37' high)	0.64w			■									
15	Cure Concrete	3w			■									
16	Lower Salado Compacted Clay Column-107'	3.06w			■									
17	Emplace Bentonite Blocks (107.0' high)	3.06w			■									
18	Lower Concrete-Asphalt Waterstop-50'	8.74w			■	■								
19	Excavate for Lower Plug	1.38w			■									
20	Pour Concrete-Lower Plug (23' high-tp)	0.17w			■									
21	Excavate Waterstop	0.34w			■									
22	Place Asphalt (4' high-tp)	0.3w			■									





Project: SALT HANDLING SHAFT SEALING SCHEDULE Date: Tue 7/9/98	Task	■	Summary	■	Rolled Up Progress	■
	Progress	■	Rolled Up Task	■		
	Milestone	■	Rolled Up Milestone	◇		

Page 1

ID	Task Name	Duration	Year 1				Year 2				
			Qtr 1	Qtr 2	Qtr 3	Qtr 4	Qtr 1	Qtr 2	Qtr 3	Qtr 4	
23	Cool-down Asphalt	1w									
24	Excavate for Upper Plug	1.38w									
25	Pour Concrete-Upper Plug (23' high-ty)	0.17w									
26	Cure Concrete	4w									
27	Compacted Salt Column-580'	12.67w									
28	Emlace & Compact Crushed/Screened Salt	12.67w									
29	Middle Concrete-Asphalt Waterstop-50'	6.74w									
30	Excavate for Lower Plug	1.38w									
31	Pour Concrete-Lower Plug	0.17w									
32	Excavate Waterstop	0.34w									
33	Place Asphalt	0.3w									
34	Cool-down Asphalt	1w									
35	Excavate for Upper Plug	1.38w									
36	Pour Concrete-Upper Plug	0.17w									
37	Cure Concrete	2w									
38	Upper Salado Compacted Clay Column-335'	9.58w									
39	Emlace Bentonite Blocks	9.58w									
40	Upper Concrete-Asphalt Waterstop-50'	8.74w									
41	Excavate for Lower Plug	1.38w									
42	Pour Concrete-Lower Plug	0.17w									
43	Excavate Waterstop	0.34w									
44	Place Asphalt	0.3w									





Project: SALT HANDLING SHAFT SEALING SCHEDULE Date: Tue 7/9/96	Task		Summary		Rolled Up Progress	
	Progress		Rolled Up Task			
	Milestone		Rolled Up Milestone			

ID	Task Name	Duration	Year 1				Year 2				Qtr 1
			Qtr 1	Qtr 2	Qtr 3	Qtr 4	Qtr 1	Qtr 2	Qtr 3	Qtr 4	
45	Cool-down Asphalt	1w									
46	Excavate for Upper Plug	1.38w									
47	Pour Concrete-Upper Plug	0.17w									
48	Cure Concrete	4w									
49	Asphalt Column-140'	15.33w									
50	Remove Lining in Key	2.02w									
51	Remove Chemical Seal Rings	0.4w									
52	Mobilize to emplace asphalt	2w									
53	Asphalt in Salt Section	2.73w									
54	Asphalt in Lower Lined Section	0.25w									
55	Complete Asphalt Emplacement	1.5w									
56	Cool-down Asphalt	6.43w									
57	Concrete Plug-20'	5.32w									
58	Remove Concrete Lining & Rock	1.11w									
59	Pour Concrete (20' high)	0.21w									
60	Cure Concrete	4w									
61	Remove Concrete Shaft Lining	1.9w									
62	Remove 72' of lining-4 zones	1.9w									
63	Rustler Compacted Clay Column-234'	4.81w									
64	Emplace & Compact Bentonite (234' high)	4.81w									
65	Compacted Earthen Fill-449'	3.65w									
66	Emplace & Compact Earthen Fill (449' high)	3.65w									

Project: SALT HANDLING SHAFT SEALING SCHEDULE Date: Tue 7/9/96	Task  Summary  Rolled Up Progress  Progress  Rolled Up Task Milestone  Rolled Up Milestone
---	---

Page 3





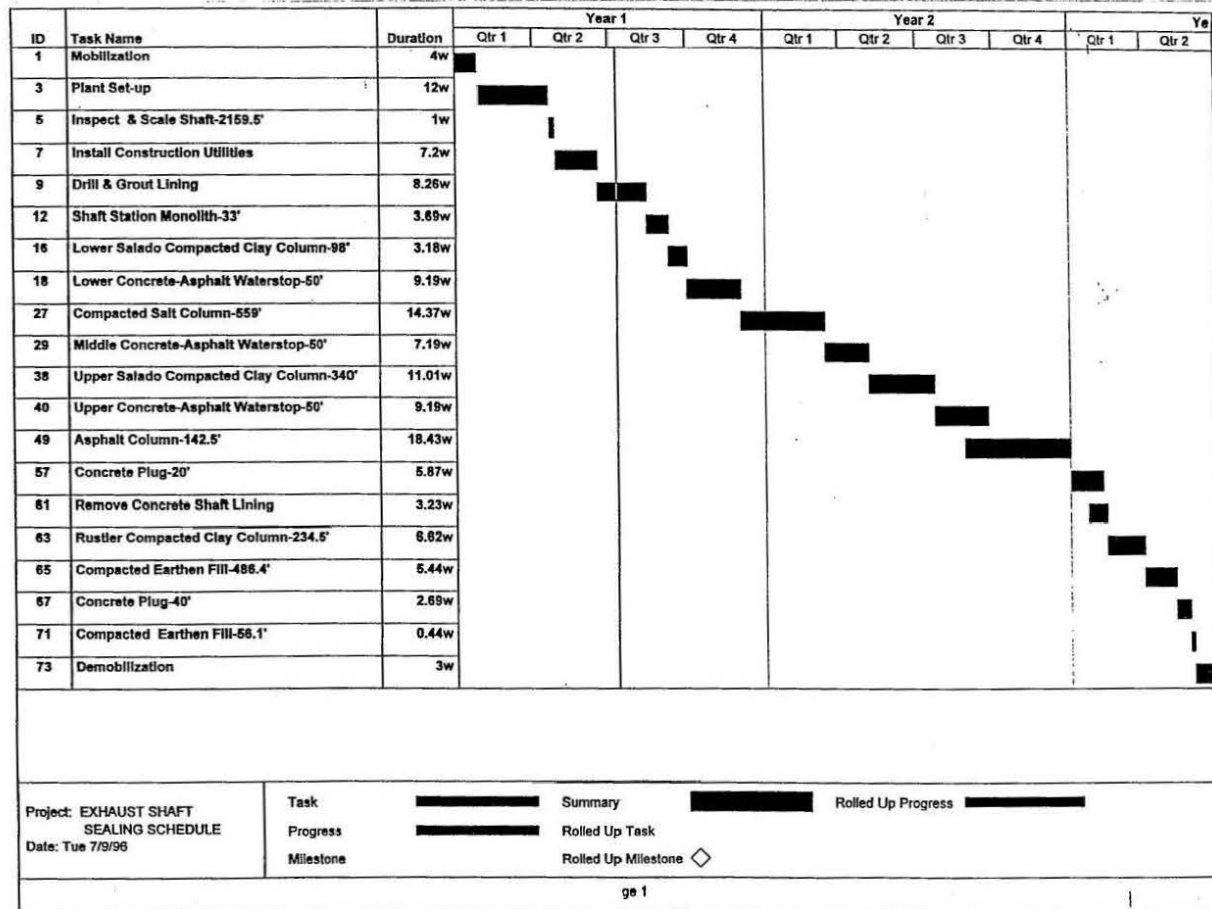

ID	Task Name	Duration	Year 1				Year 2				Qtr 1	
			Qtr 1	Qtr 2	Qtr 3	Qtr 4	Qtr 1	Qtr 2	Qtr 3	Qtr 4		
67	Concrete Plug-40'	2.45w										■
68	Clean Existing Surface	0.34w										
69	Pour Concrete	0.11w										
70	Cure Concrete	2w										■
71	Compacted Earthen Fill-92.5'	0.85w										■
72	Emplace & Compact Earthen Fill (92.5'high)	0.65w										■
73	Demobilization	3w										■
74	Demob	3w										■

Project: SALT HANDLING SHAFT SEALING SCHEDULE Date: Tue 7/9/96	Task  Summary  Rolled Up Progress  Progress  Rolled Up Task Milestone  Rolled Up Milestone
--	---

SEALING SCHEDULE - EXHAUST SHAFT



ID	Task Name	Duration	Year 1				Year 2				Year 3	
			Qtr 1	Qtr 2	Qtr 3	Qtr 4	Qtr 1	Qtr 2	Qtr 3	Qtr 4	Qtr 1	Qtr 2
1	Mobilization	4w	█									
2	Mobilize	4w	█									
3	Plant Set-up	12w	█	█								
4	Plant Set-up	12w	█	█								
5	Inspect & Scale Shaft-2159.5'	1w			█							
6	Inspect & Scale Shaft	1w			█							
7	Install Construction Utilities	7.2w		█								
8	Install Utilities	7.2w		█								
9	Drill & Grout Lining	8.26w			█							
10	Drill Grout Holes	3.3w			█							
11	Grout Lining	4.96w			█							
12	Shaft Station Monolith-33'	3.69w				█						
13	Construct Bulkheads	0.4w					█					
14	Pour Concrete (33' high)	0.29w						█				
15	Cure Concrete	3w							█			
16	Lower Salado Compacted Clay Column-98'	3.18w								█		
17	Emlace Bentonite Blocks (98' high)	3.18w									█	
18	Lower Concrete-Asphalt Waterstop-50'	9.19w										█
19	Excavate for Lower Plug	1.45w										█
20	Pour Concrete-Lower Plug (23' high-ty)	0.22w										█
21	Excavate Waterstop	0.47w										█
22	Place Asphalt (4' high-ty)	0.36w										█

Project: EXHAUST SHAFT SEALING SCHEDULE Date: Tue 7/9/95	Task  Summary  Rolled Up Progress  Progress  Rolled Up Task  Milestone  Rolled Up Milestone 
--	--

Page 1

ID	Task Name	Duration	Year 1				Year 2				Year 3		
			Qtr 1	Qtr 2	Qtr 3	Qtr 4	Qtr 1	Qtr 2	Qtr 3	Qtr 4	Qtr 1	Qtr 2	
23	Cool-down Asphalt	1w											
24	Excavate for Upper Plug	1.45w											
25	Pour Concrete-Upper Plug (23' high-tp)	0.22w											
26	Cure Concrete	4w											
27	Compacted Salt Column-559'	14.37w											
28	Eplace & Compact Crushed/Screened Salt	14.37w											
29	Middle Concrete-Asphalt Waterstop-50'	7.19w											
30	Excavate for Lower Plug	1.45w											
31	Pour Concrete-Lower Plug	0.22w											
32	Excavate Waterstop	0.47w											
33	Place Asphalt	0.38w											
34	Cool-down Asphalt	1w											
35	Excavate for Upper Plug	1.45w											
36	Pour Concrete-Upper Plug	0.22w											
37	Cure Concrete	2w											
38	Upper Salado Compacted Clay Column-340'	11.01w											
39	Eplace Bentonite Blocks(340' high)	11.01w											
40	Upper Concrete-Asphalt Waterstop-50'	9.19w											
41	Excavate for Lower Plug	1.45w											
42	Pour Concrete-Lower Plug	0.22w											
43	Excavate Waterstop	0.47w											
44	Place Asphalt	0.38w											

Project: EXHAUST SHAFT SEALING SCHEDULE Date: Tue 7/9/96	Task Summary Rolled Up Progress	Progress Rolled Up Task
	Milestone Rolled Up Milestone	

12

ID	Task Name	Duration	Year 1				Year 2				Year 3	
			Qtr 1	Qtr 2	Qtr 3	Qtr 4	Qtr 1	Qtr 2	Qtr 3	Qtr 4	Qtr 1	Qtr 2
45	Cool-down Asphalt	1w										
46	Excavate for Upper Plug	1.45w										
47	Pour Concrete-Upper Plug	0.22w										
48	Cure Concrete	4w										
49	Asphalt Column-142.5'	18.43w										
50	Remove Lining in Key	3.15w										
51	Remove Chemical Seal Rings	0.5w										
52	Mobilize to Emerge Asphalt	2w										
53	Asphalt in Salt Section	2.64w										
54	Asphalt in Lower Lined Section	1.44w										
55	Complete Asphalt Emplacement	2.27w										
56	Cool-down Asphalt	6.43w										
57	Concrete Plug-20'	5.87w										
58	Remove Concrete Lining & Rock	1.7w										
59	Pour Concrete (20' high)	0.17w										
60	Cure Concrete	4w										
61	Remove Concrete Shaft Lining	3.23w										
62	Remove 84' of lining-4 zones	3.23w										
63	Rustler Compacted Clay Column-234.5'	6.62w										
64	Emerge & Compact Bentonite(234.5' high)	6.62w										
65	Compacted Earthen Fill-486.4'	5.44w										
66	Emerge & Compact Earthen Fill(486.4' high)	5.44w										

Project: EXHAUST SHAFT SEALING SCHEDULE Date: Tue 7/9/96	Task Progress Milestone	Summary Rolled Up Task Rolled Up Milestone	Rolled Up Progress
--	-------------------------------	--	--------------------

Page 3

ID	Task Name	Duration	Year 1				Year 2				Year 3		
			Qtr 1	Qtr 2	Qtr 3	Qtr 4	Qtr 1	Qtr 2	Qtr 3	Qtr 4	Qtr 1	Qtr 2	
67	Concrete Plug-40'	2.69w											
68	Clean Existing Surface	0.47w											■
69	Pour Concrete	0.22w											
70	Cure Concrete	2w											■
71	Compacted Earthen Fill-56.1'	0.44w											
72	Emlace & Compact Earthen Fill (56.1'high)	0.44w											
73	Demobilization	3w											■
74	Demob	3w											■

Project: EXHAUST SHAFT SEALING SCHEDULE Date: Tue 7/9/96	Task Summary Progress Rolled Up Task Milestone Rolled Up Milestone	Rolled Up Progress
--	---	--------------------

SEALING SCHEDULE - WASTE SHAFT

ID	Task Name	Duration	Year 1				Year 2				Year 3				Ye	
			Qtr 1	Qtr 2	Qtr 3	Qtr 4	Qtr 1	Qtr 2	Qtr 3	Qtr 4	Qtr 1	Qtr 2	Qtr 3	Qtr 4	Qtr 1	Qtr 2
1	Mobilization	4w	■													
3	Plant Set-up	12w	■	■												
5	Inspect & Scale Shaft-2159.5'	1w		■												
7	Install Construction Utilities	7.2w		■												
9	Drill & Grout Lining	11.21w			■											
12	Shaft Station Monolith-37'	5.17w				■										
16	Lower Salado Compacted Clay Column-96'	5.01w					■									
18	Lower Concrete-Asphalt Waterstop-50'	12.57w					■									
27	Compacted Salt Column-555.5'	22.87w						■								
29	Middle Concrete-Asphalt Waterstop-50'	10.57w						■								
38	Upper Salado Compacted Clay Column-351.5'	17.86w							■							
40	Upper Concrete-Asphalt Waterstop-50'	12.57w							■							
49	Asphalt Column-142.3'	20.71w								■						
57	Concrete Plug-20'	5.98w									■					
61	Remove Concrete Shaft Lining	5.07w										■				
63	Rustler Compacted Clay Column-234.7'	10.99w											■			
65	Compacted Earthen Fill-447'	8.25w												■		
67	Concrete Plug-40'	3.04w													■	
71	Compacted Earthen Fill-51.5'	1.14w														■
73	Demobilization	3.5w														■

Project: WASTE HANDLING SHAFT SEALING SCHEDULE Date: Tue 7/9/96	Task Progress Milestone	Summary Rolled Up Task Rolled Up Milestone ◊	Rolled Up Progress
---	-------------------------------	--	--------------------

ID	Task Name	Duration	Year 1				Year 2				Year 3				Ye	
			Qtr 1	Qtr 2	Qtr 3	Qtr 4	Qtr 1	Qtr 2	Qtr 3	Qtr 4	Qtr 1	Qtr 2	Qtr 3	Qtr 4	Qtr 1	Qtr 2
1	Mobilization	4w	■													
2	Mobilize	4w	■													
3	Plant Set-up	12w	■	■												
4	Plant Set-up	12w	■	■												
5	Inspect & Scale Shaft-2159.5'	1w			■											
6	Inspect & Scale Shaft	1w			■											
7	Install Construction Utilities	7.2w		■												
8	Install Utilities	7.2w		■												
9	Drill & Grout Lining	11.21w			■	■										
10	Drill Grout Holes	4.48w			■											
11	Grout Lining	6.73w			■											
12	Shaft Station Monolith-37'	5.17w				■										
13	Construct Bulkheads	1w				■										
14	Pour Concrete (37' high)	1.17w				■										
15	Cure Concrete	3w				■										
16	Lower Salado Compacted Clay Column-96'	5.01w					■									
17	Eplace Bentonite Blocks (96' high)	5.01w					■									
18	Lower Concrete-Asphalt Waterstop-50'	12.57w						■	■							
19	Excavate for Lower Plug	2.72w						■								
20	Pour Concrete-Lower Plug (23' high-ty)	0.27w						■								
21	Excavate Waterstop	0.84w						■								
22	Place Asphalt (4' high-ty)	0.75w						■								





Project: WASTE HANDLING SHAFT SEALING SCHEDULE Date: Tue 7/9/96	Task	■	Summary	■	Rolled Up Progress	■
	Progress	■	Rolled Up Task	■		
	Milestone	◇	Rolled Up Milestone	◇		

Page 1

ID	Task Name	Duration	Year 1				Year 2				Year 3				Year 4	
			Qtr 1	Qtr 2	Qtr 3	Qtr 4	Qtr 1	Qtr 2	Qtr 3	Qtr 4	Qtr 1	Qtr 2	Qtr 3	Qtr 4	Qtr 1	Qtr 2
23	Cool-down Asphalt	1w														
24	Excavate for Upper Plug	2.72w														
25	Pour Concrete-Upper Plug (23' high-ty)	0.27w														
26	Cure Concrete	4w														
27	Compacted Salt Column-555.5'	22.87w														
28	Emplace & Compact Crushed/Screened Salt	22.87w														
29	Middle Concrete-Asphalt Waterstop-50'	10.57w														
30	Excavate for Lower Plug	2.72w														
31	Pour Concrete-Lower Plug	0.27w														
32	Excavate Waterstop	0.84w														
33	Place Asphalt	0.75w														
34	Cool-down Asphalt	1w														
35	Excavate for Upper Plug	2.72w														
36	Pour Concrete-Upper Plug	0.27w														
37	Cure Concrete	2w														
38	Upper Salado Compacted Clay Column-351.5'	17.86w														
39	Emplace Bentonite Blocks(351.5' high)	17.86w														
40	Upper Concrete-Asphalt Waterstop-50'	12.57w														
41	Excavate for Lower Plug	2.72w														
42	Pour Concrete-Lower Plug	0.27w														
43	Excavate Waterstop	0.84w														
44	Place Asphalt	0.75w														





Project: WASTE HANDLING SHAFT SEALING SCHEDULE Date: Tue 7/9/96	Task		Summary		Rolled Up Progress	
	Progress		Rolled Up Task			
	Milestone		Rolled Up Milestone			

ID	Task Name	Duration	Year 1				Year 2				Year 3				Ye	
			Qtr 1	Qtr 2	Qtr 3	Qtr 4	Qtr 1	Qtr 2	Qtr 3	Qtr 4	Qtr 1	Qtr 2	Qtr 3	Qtr 4	Qtr 1	Qtr 2
45	Cool-down Asphalt	1w														
46	Excavate for Upper Plug	2.72w														
47	Pour Concrete-Upper Plug	0.27w														
48	Cure Concrete	4w														
49	Asphalt Column-142.3'	20.71w														
50	Remove Lining in Key	3.8w														
51	Remove Chemical Seal Rings	0.6w														
52	Mobilize to emplace asphalt	0.3w														
53	Asphalt in Salt Section	4.01w														
54	Asphalt in Lower Lined Section	2.33w														
55	Complete Asphalt Emplacement	3.24w														
56	Cool-down Asphalt	6.43w														
57	Concrete Plug-20'	5.98w														
58	Remove Concrete Lining & Rock	1.73w														
59	Pour Concrete (20' high)	0.25w														
60	Cure Concrete	4w														
61	Remove Concrete Shaft Lining	5.07w														
62	Remove 64' of lining-4 zones	5.07w														
63	Rustler Compacted Clay Column-234.7'	10.99w														
64	Eplace & Compact Bentonite (234.7' high)	10.99w														
65	Compacted Earthen Fill-447'	8.25w														
66	Eplace & Compact Earthen Fill (447' high)	8.25w														

Project: WASTE HANDLING SHAFT SEALING SCHEDULE Date: Tue 7/9/96	Task  Summary  Rolled Up Progress  Progress  Rolled Up Task Milestone  Rolled Up Milestone
--	---

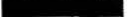
Page 3

ID	Task Name	Duration	Year 1				Year 2				Year 3				Year
			Qtr 1	Qtr 2	Qtr 3	Qtr 4	Qtr 1	Qtr 2	Qtr 3	Qtr 4	Qtr 1	Qtr 2	Qtr 3	Qtr 4	
67	Concrete Plug-40'	3.04w													
68	Clean Existing Surface	0.64w													
69	Pour Concrete	0.4w													
70	Cure Concrete	2w													
71	Compacted Earthen Fill-61.5'	1.14w													
72	Emlace & Compact Earthen Fill (61.5' high)	1.14w													
73	Demobilization	3.5w													
74	Demob	3.5w													

Project: WASTE HANDLING SHAFT SEALING SCHEDULE Date: Tue 7/9/98	Task  Summary  Rolled Up Progress 
	Progress  Rolled Up Task
	Milestone  Rolled Up Milestone 

B5. References

Ahrens, E.H., and F.D. Hansen. 1995. *Large-Scale Dynamic Compaction Demonstration Using WIPP Salt: Fielding and Preliminary Results*. SAND95-1941. Albuquerque, NM: Sandia National Laboratories. (Copy on file in the Sandia WIPP Central Files, Sandia National Laboratories, Albuquerque, NM [SWCF] as WPO31104.)

Ahrens, E.H., and M. Onofrei. 1996. "Ultrafine Cement Grout for Sealing Underground Nuclear Waste Repositories," *2nd North American Rock Mechanics Symposium (NARMS 96), Montreal, Quebec, June 19-21, 1996*. SAND96-0195C. Albuquerque, NM: Sandia National Laboratories. (Copy on file in the SWCF as WPO31251.)

Ahrens, E.H., T.F. Dale, and R.S. Van Pelt. 1996. *Data Report on the Waste Isolation Pilot Plant Small-Scale Seal Performance Test, Series F Grouting Experiment*. SAND93-1000. Albuquerque, NM: Sandia National Laboratories. (Copy on file in the SWCF as WPO37355.)

Boonsinsuk, P., B.C. Pulles, B.H. Kjartanson, and D.A. Dixon. 1991. "Prediction of Compactive Effort for a Bentonite-Sand Mixture," *44th Canadian Geotechnical Conference, Preprint Volume, Calgary, Alberta, September 29-October 2, 1991*. Paper No. 64. Waterloo, Ontario: Canadian Geotechnical Society. Pt. 2, 64/1 through 64/12. (Copy on file in the SWCF.)

Dale, T., and L.D. Hurtado. 1996. "WIPP Air-Intake Shaft Disturbed-Rock Zone Study," *4th International Conference on the Mechanical Behavior of Salt, Montreal, Quebec, June 17-18, 1996*. SAND96-1327C. Albuquerque, NM: Sandia National Laboratories. (Copy on file in the SWCF.)

Hansen, F.D., and E.H. Ahrens. 1996. "Large-Scale Dynamic Compaction of Natural Salt," *4th International Conference on the Mechanical Behavior of Salt, Montreal, Quebec, June 17-18, 1996*. SAND96-0792C. Albuquerque, NM: Sandia National Laboratories. (Copy on file in the SWCF as WPO39544.)

Knowles, M.K., and C.L. Howard. 1996. "Field and Laboratory Testing of Seal Materials Proposed for the Waste Isolation Pilot Plant," *Proceedings of the Waste Management 1996 Symposium, Tucson, AZ, February 25-29, 1996*. SAND95-2082C. Albuquerque, NM: Sandia National Laboratories. (Copy on file in the SWCF as WPO30945.)

McClintock, F.A., and A.S. Aragon. 1996. *Mechanical Behavior of Materials*. Reading MA: Addison-Wesley.

Sandia (Repository Isolation Systems Department 6121). 1996. *Waste Isolation Pilot Plant Shaft Sealing System Compliance Submittal Design Report*. SAND96-1326/1&2. Albuquerque, NM: Sandia National Laboratories.

Van Sambeek, L.L. 1988. *Considerations for the Use of Quarried Salt Blocks in Seal Components at the WIPP*. Topical Report RSI-0340. Rapid City, SD: RE/SPEC Inc. (Copy on file in the SWCF as WPO9233.)

FIGURES

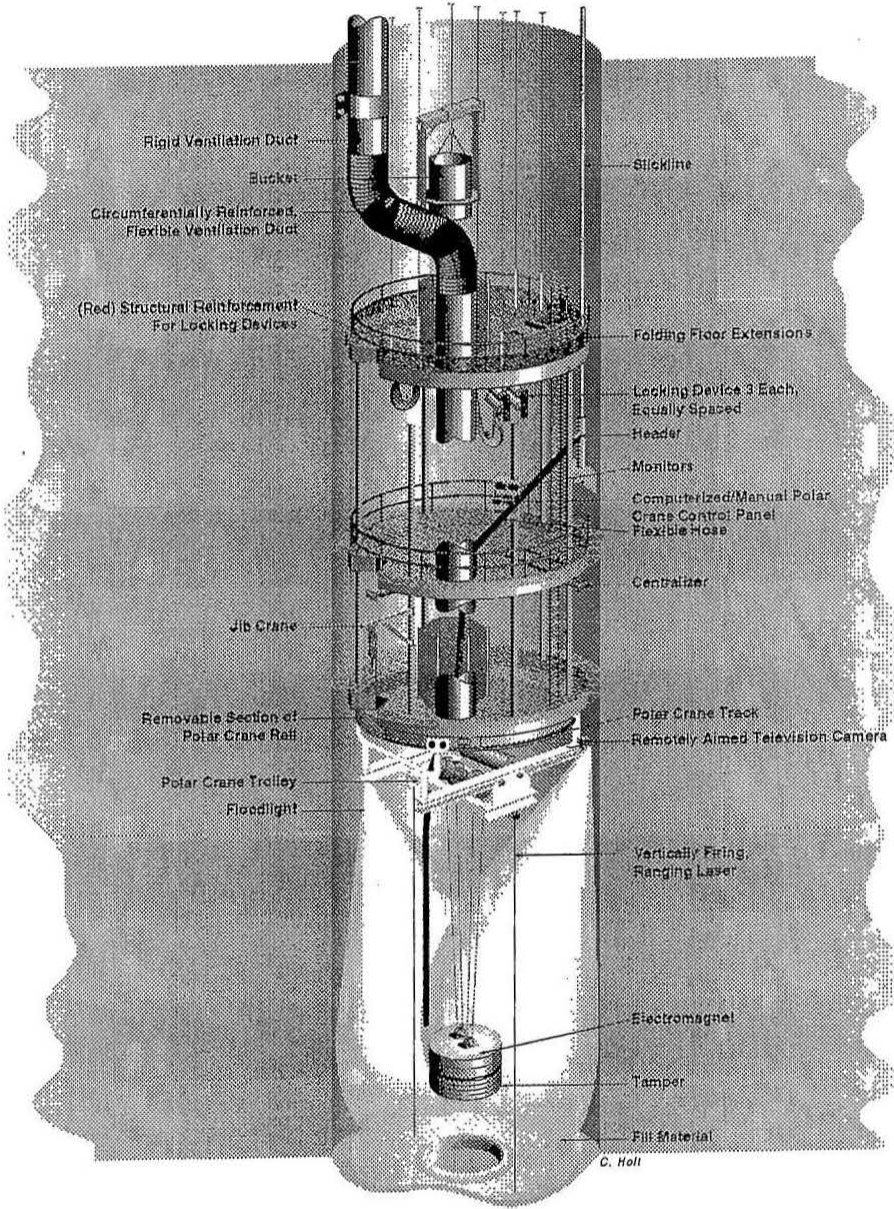

Figure G2B-1
Multi-Deck Stage Illustrating Dynamic Compaction

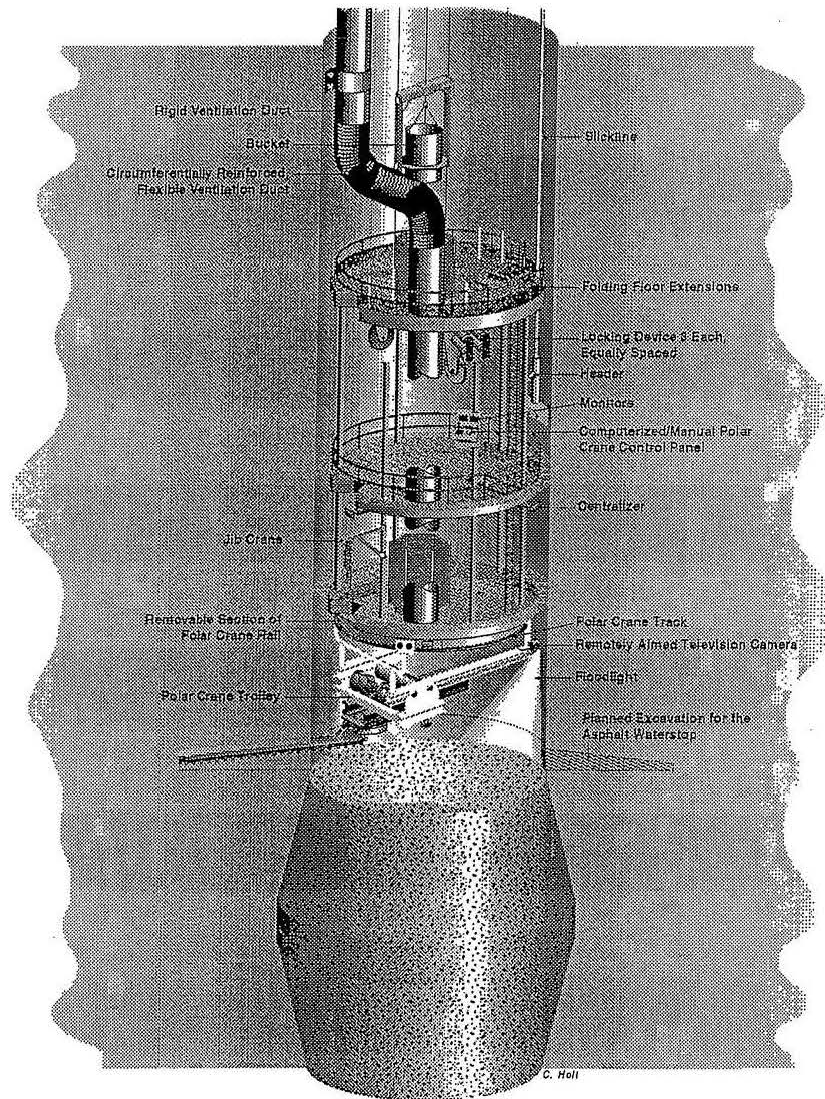
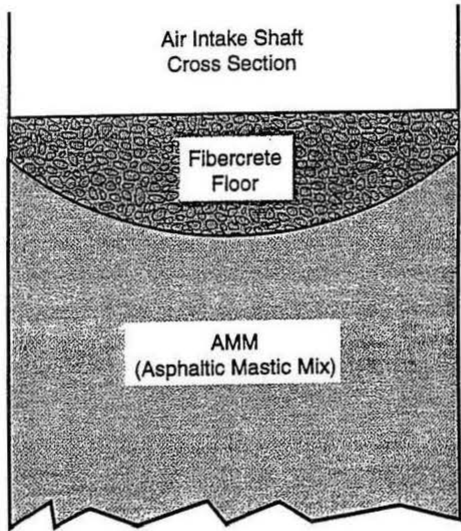
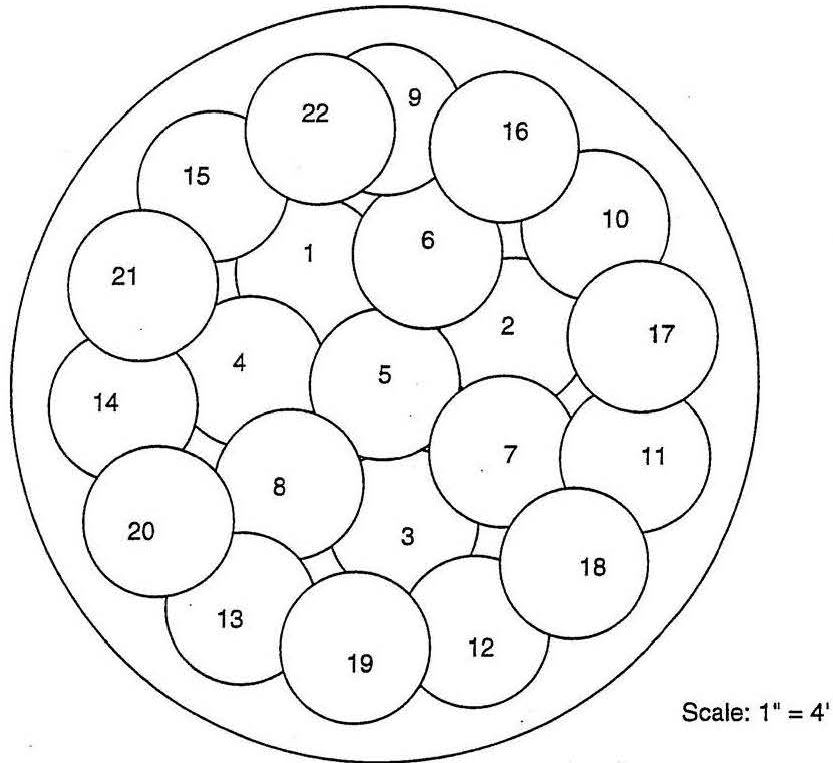

Figure G2B-2
Multi-Deck Stage Illustrating Excavation for Asphalt Waterstop



TRI-6121-375-0

Figure G2B-3
Typical Fibercrete at Top of Asphalt



TRI-6121-376-0

Figure G2B-4
Drop Pattern for 6-m-Diameter Shaft Using a 1.2-m-Diameter Tamper

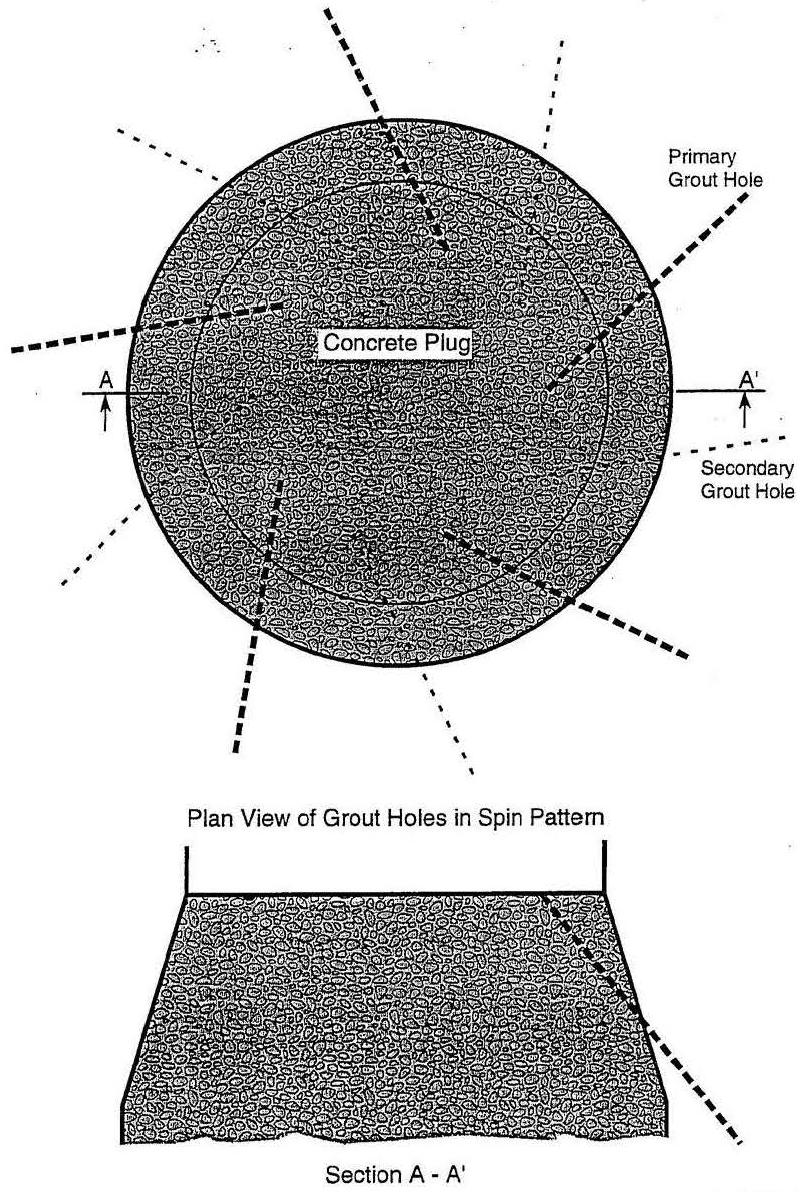

TRI-6121-373-0

Figure G2B-5
Plan and Section Views of Downward Spin Pattern of Grout Holes

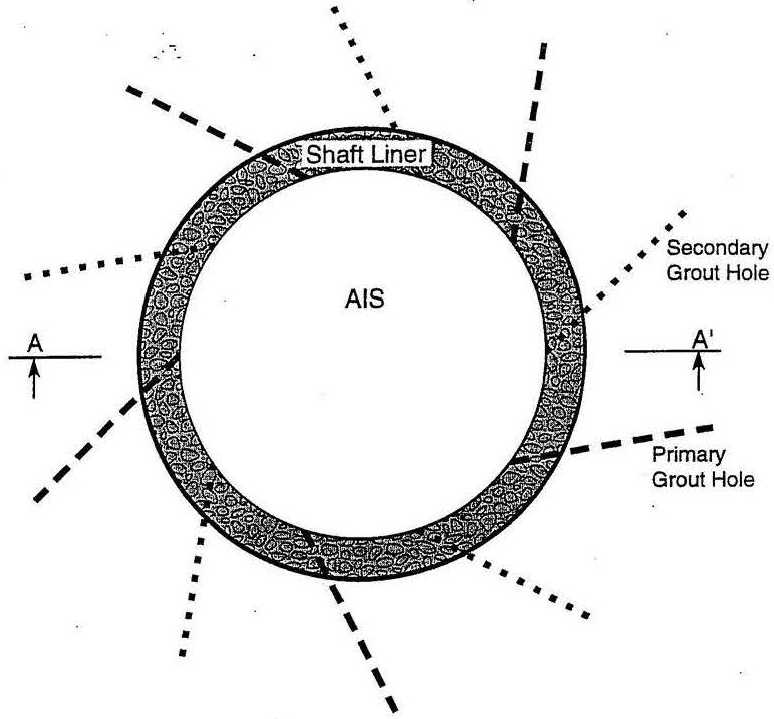

Plan View of Grout Holes in Spin Pattern



Section A - A'

TRI-6121-374-0

Figure G2B-6
Plan and Section Views of Upward Spin Pattern of Grout Holes

**ATTACHMENT G2
APPENDIX G2-E**

DESIGN DRAWINGS

**SHAFT SEALING SYSTEM
COMPLIANCE SUBMITTAL DESIGN REPORT**

SAND96-1326/2
Unlimited Release
Printed August 1996

Distribution
Category UC-721

**Waste Isolation Pilot Plant
Shaft Sealing System
Compliance Submittal Design Report**

**Volume 2 of 2:
Appendix E**

Repository Isolation Systems Department
Sandia National Laboratories
Albuquerque, NM 87185

ABSTRACT

This is the second volume of a two-volume report describing a shaft sealing system design for the Waste Isolation Pilot Plant. This appendix contains detailed drawings of the shaft sealing system and its components.

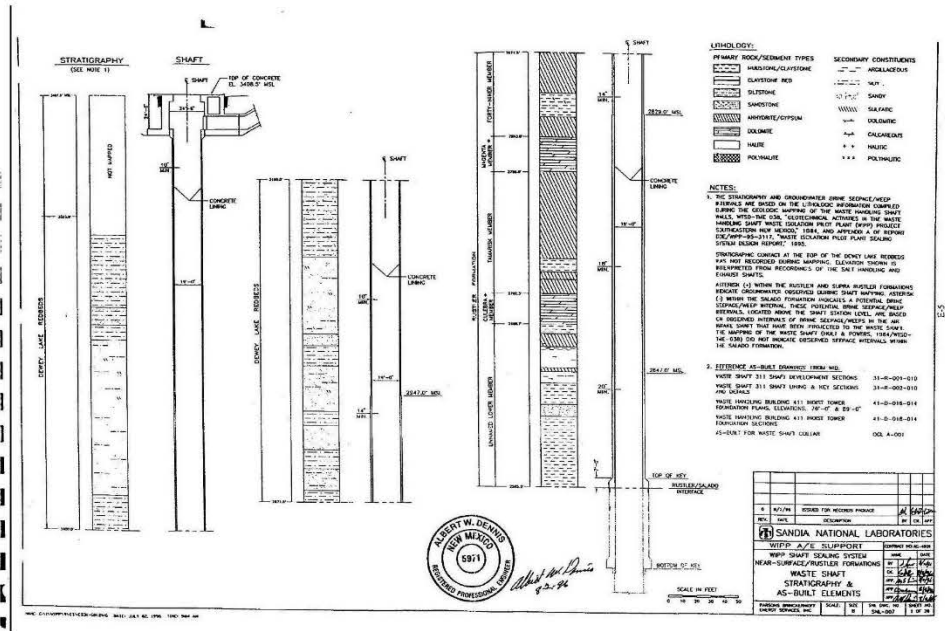

Near-Surface/Rustler Formations Waste Shaft Stratigraphy and AS-Built Elements

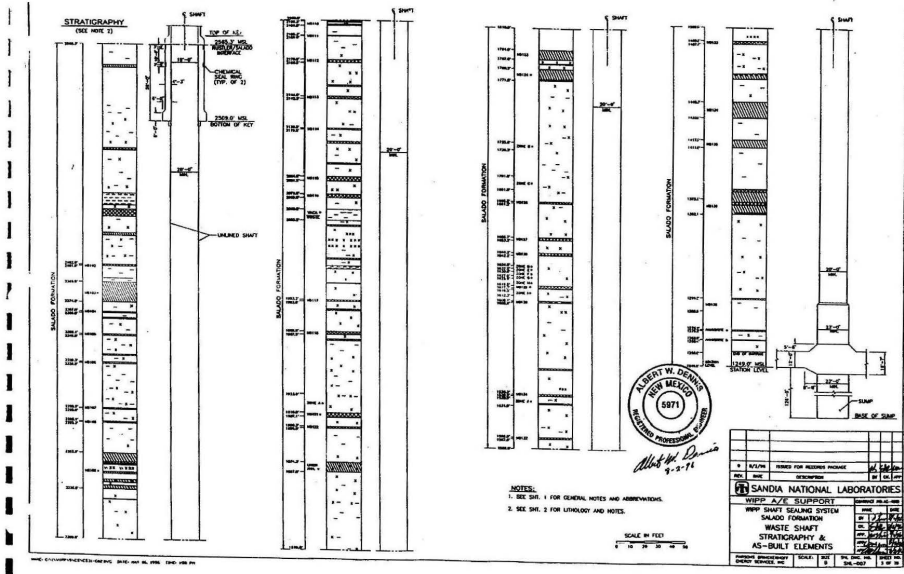

Salado Formation Waste Shaft Stratigraphy and AS-Built Elements

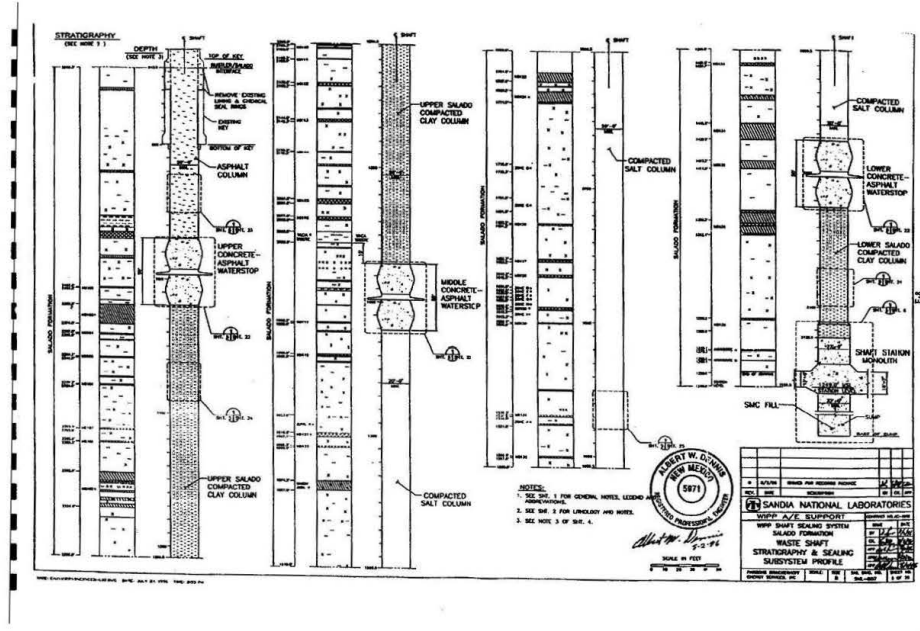

Salado Formation Waste Shaft Stratigraphy and Sealing Subsystem Profile

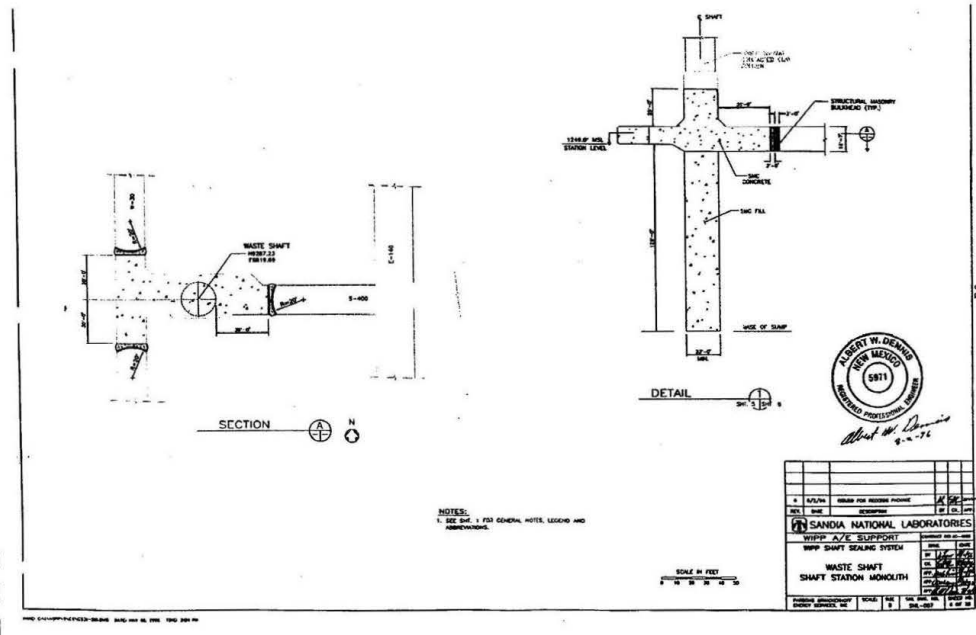

Waste Shaft Station Monolith

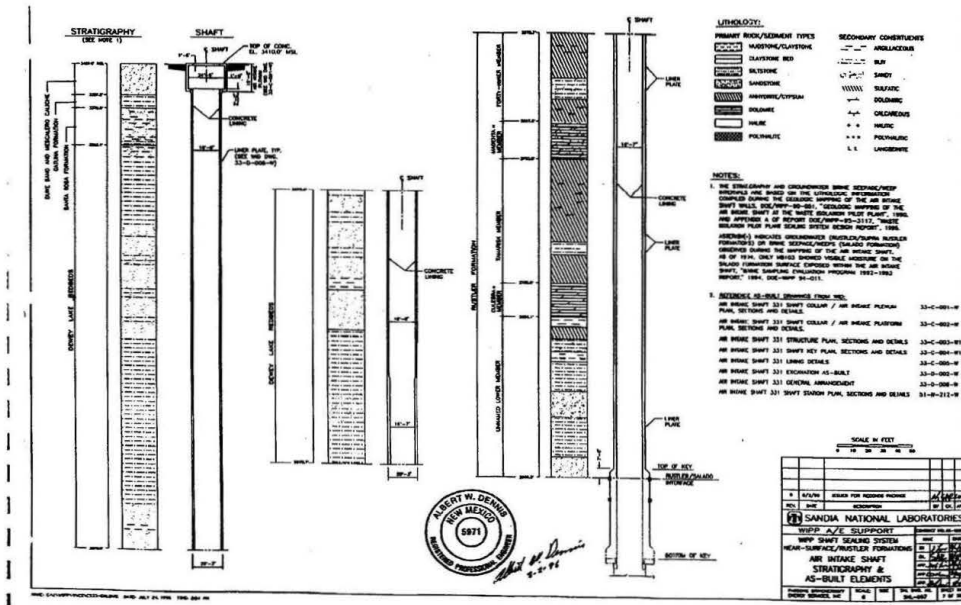

Near-Surface / Rustler Formations Air Intake Shaft Stratigraphy and AS-Built Elements

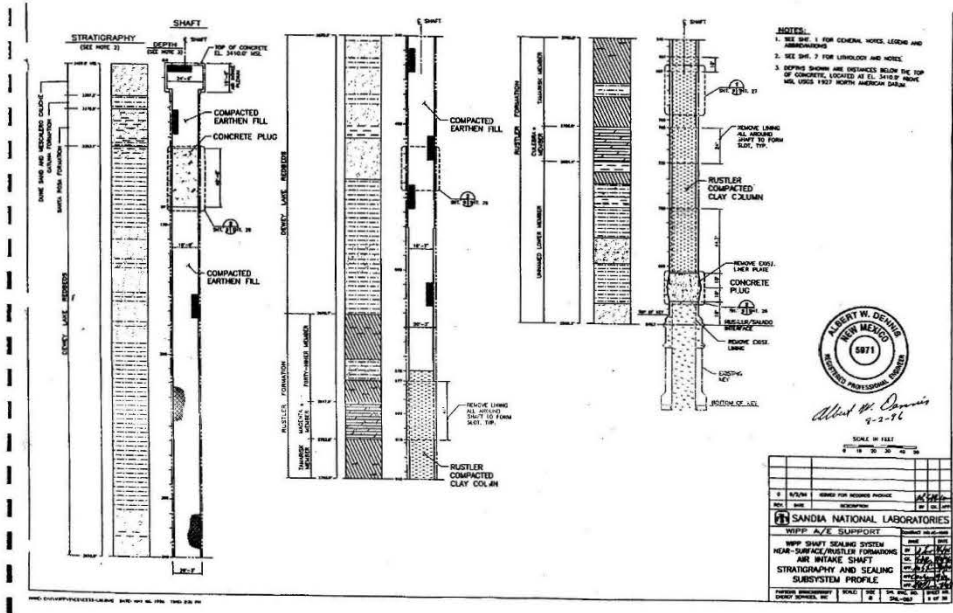

Near-Surface / Rustler Formations Air Intake Shaft Stratigraphy and Sealing Subsystem Profile

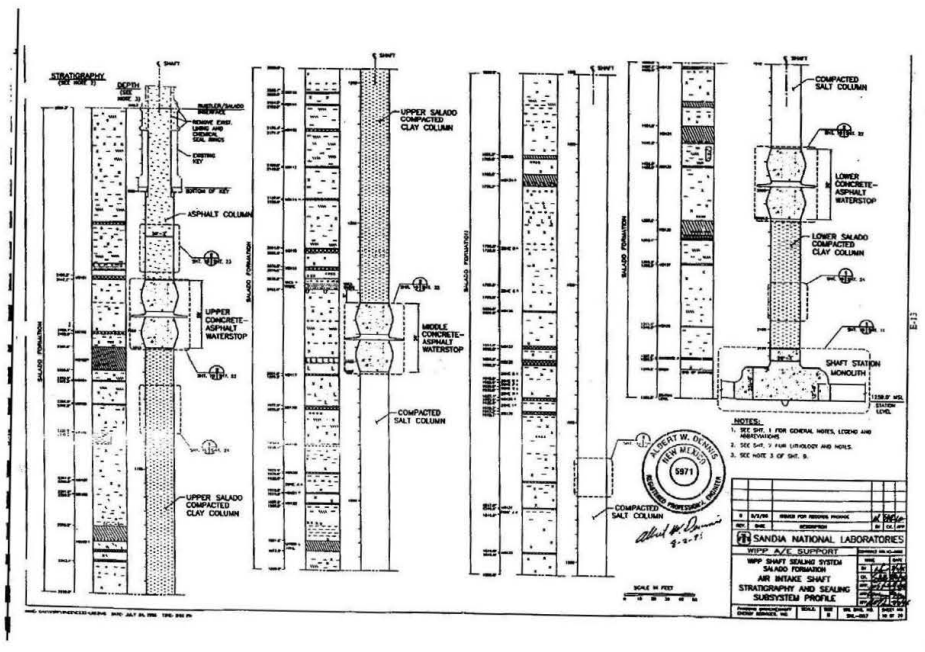

Salado Formation Air Intake Shaft Stratigraphy and Sealing Subsystem Profile

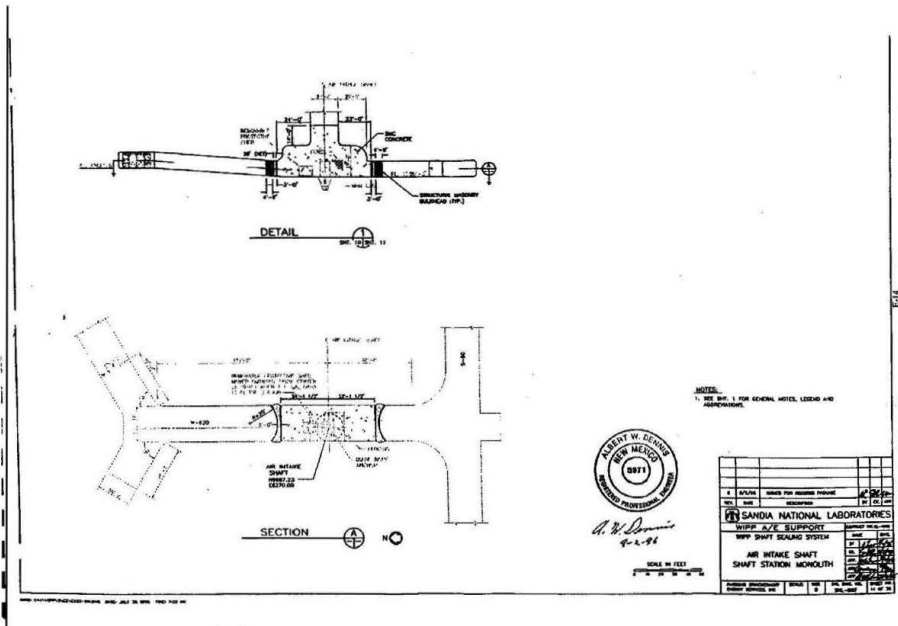

Air Intake Shaft Station Monolith

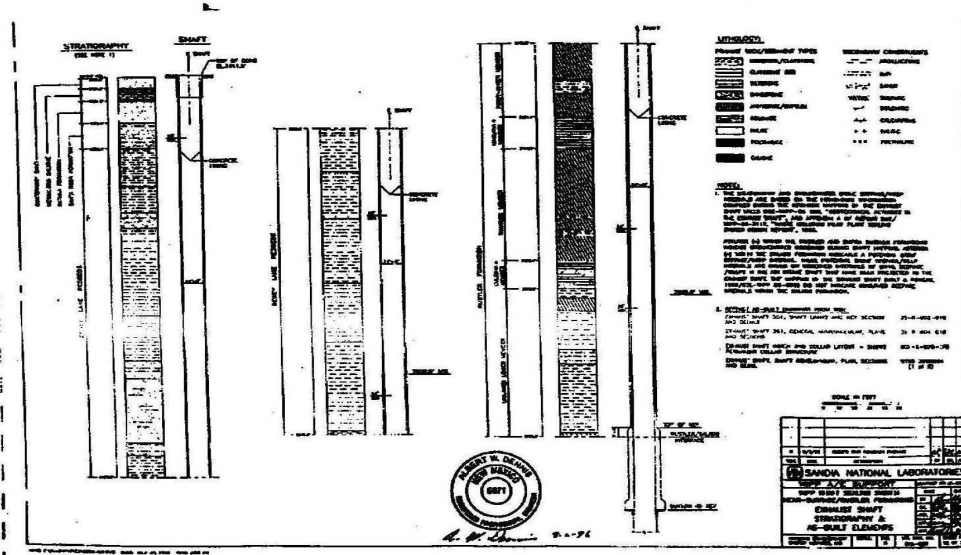

Near-Surface / Rustler Formations Exhaust Shaft Stratigraphy and AS-Built Elements Sheet 12 of 28

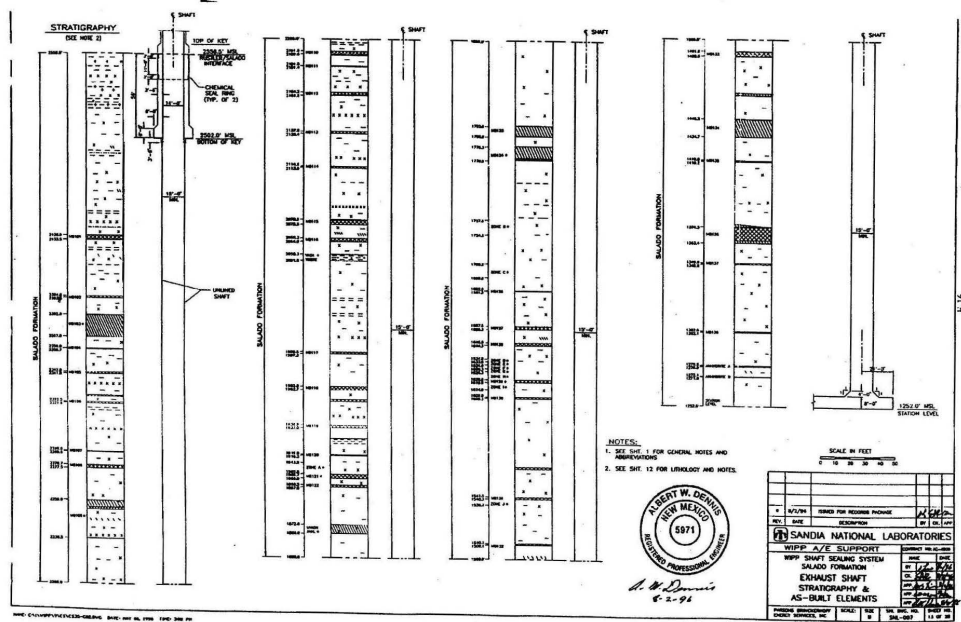

Salado Formation Exhaust Shaft Stratigraphy and AS-Built Elements

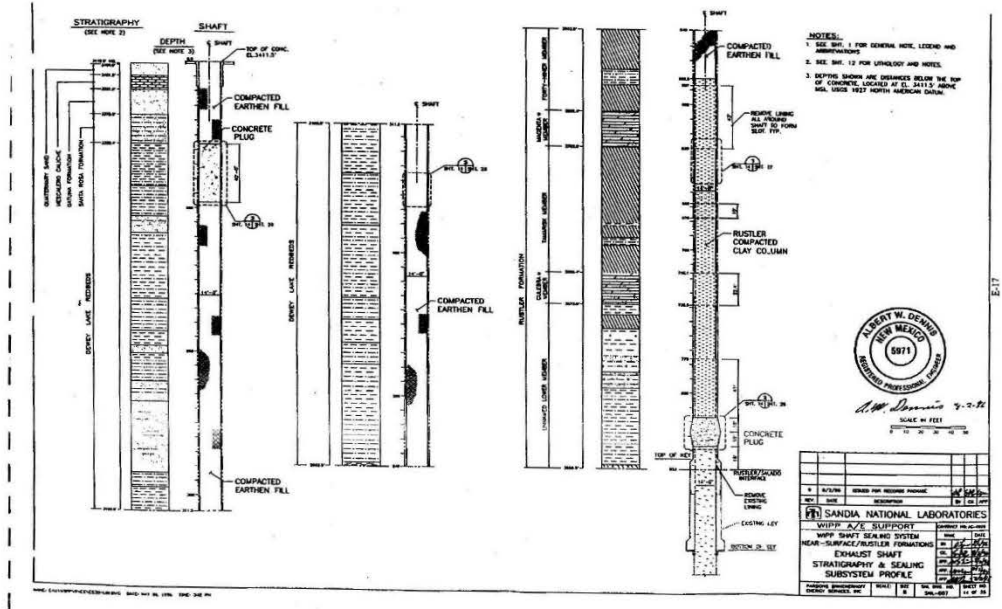

Near-Surface / Rustler Formations Exhaust Shaft Stratigraphy and Sealing Subsystem Profile

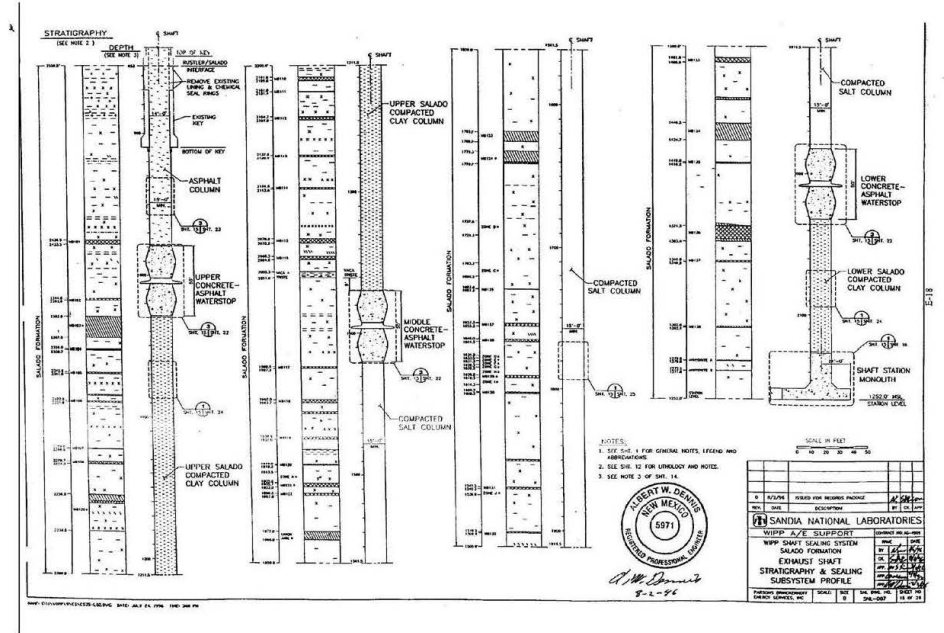

Salado Formation Exhaust Shaft Stratigraphy and Sealing Subsystem Profile

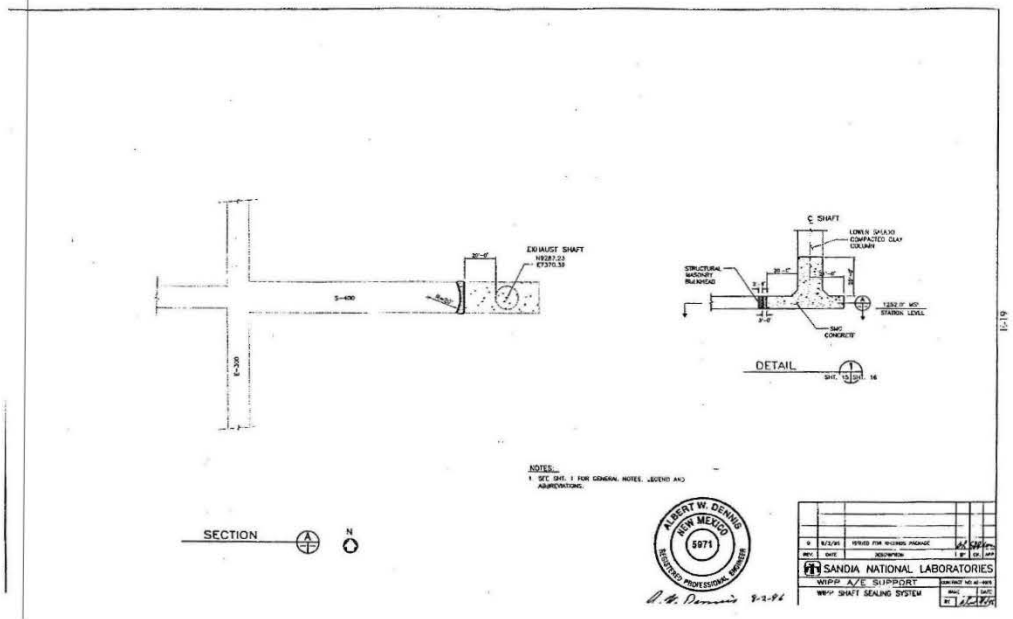

Exhaust Shaft Station Monolith

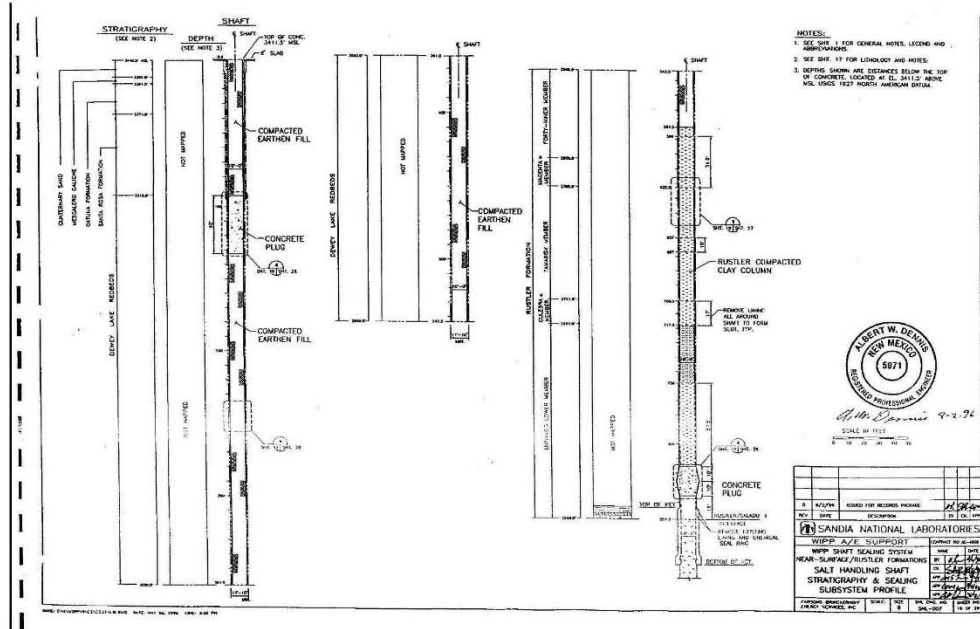

Near-Surface / Ruster Formations Salt Handling Shaft Stratigraphy and Sealing Subsystem Profile

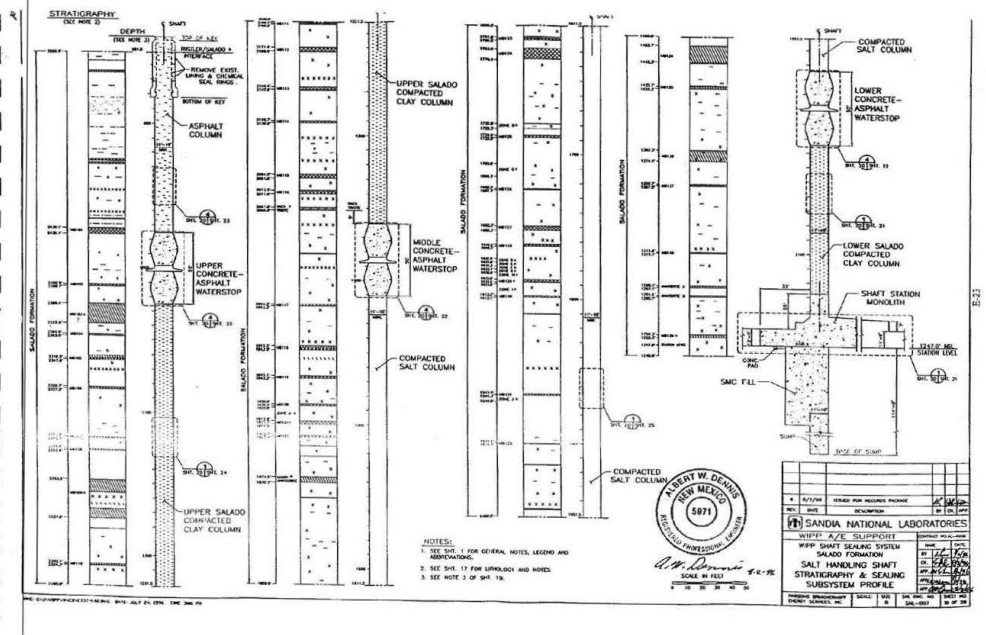

Salado Formation Salt Handling Shaft Stratigraphy and Sealing Subsystem Profile

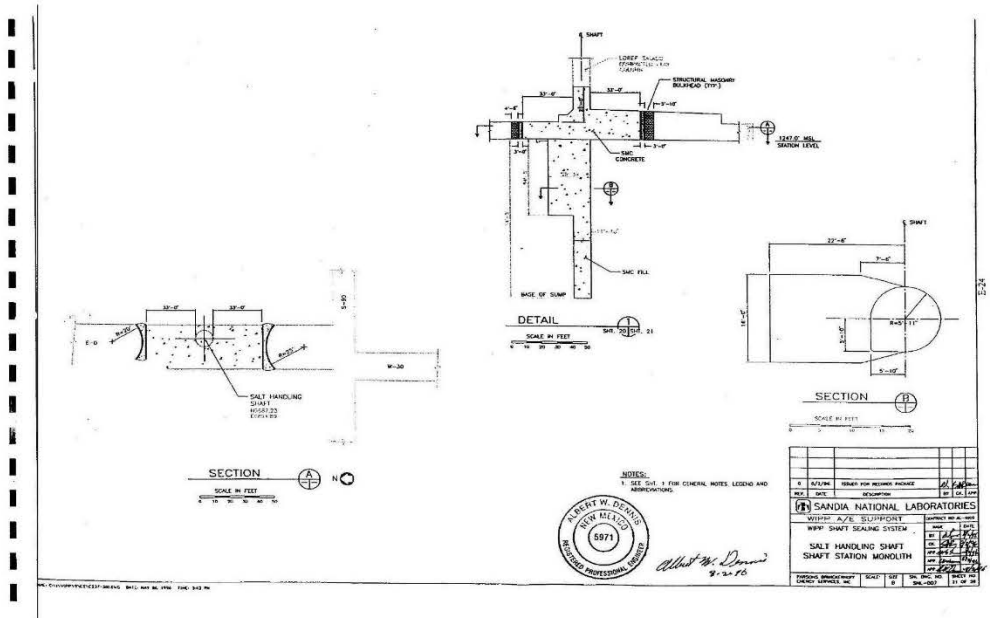

Salt Handling Shaft Shaft Station Monolith

Sheet 21 of 28

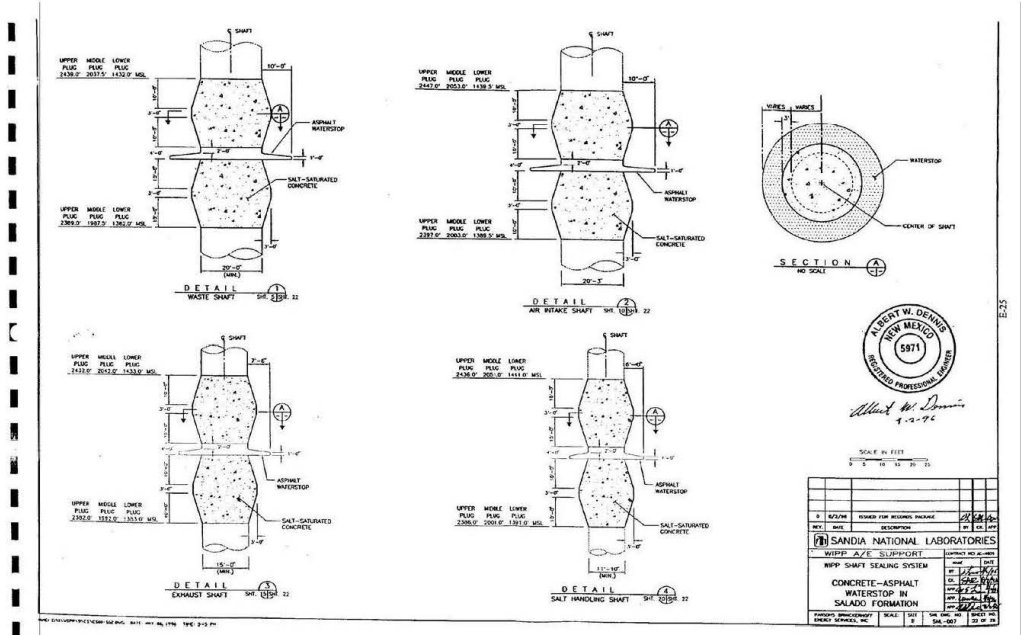

Concrete-Asphalt Water Stop in Salado Formation

Sheet 22 of 28

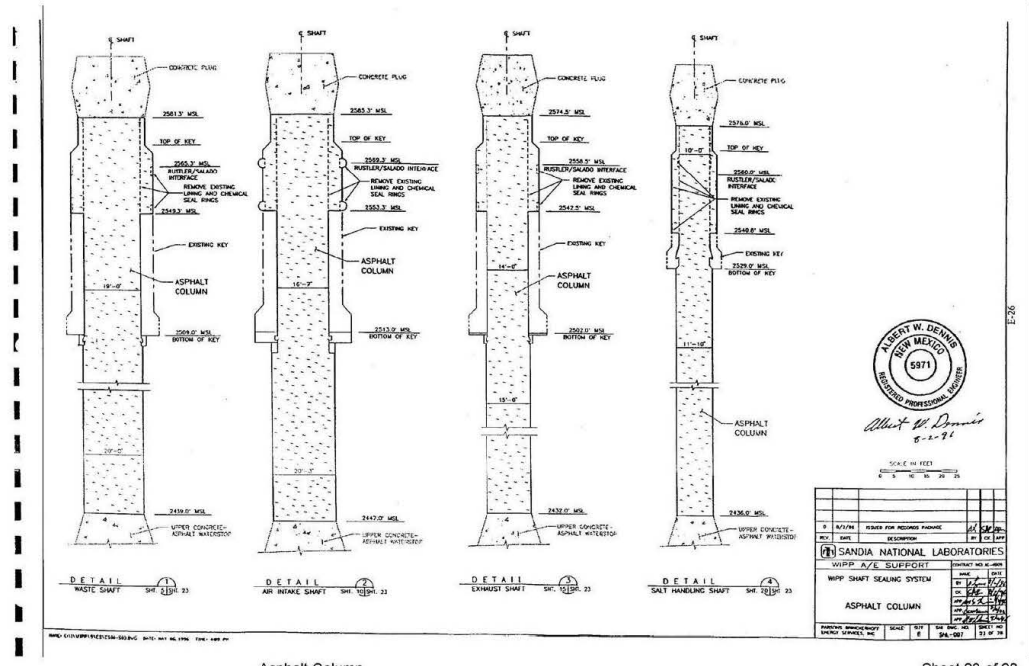

Asphalt Column

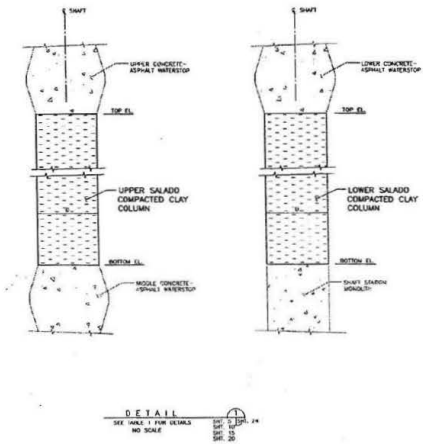

TABLE 1

SHAFT	NORMAL SHAFT DIAMETER D	UPPER SALADO COMPACTED CLAY COLUMN			LOWER SALADO COMPACTED CLAY COLUMN		
		TOP EL. (FT. MSL.)	BOTTOM EL. (FT. MSL.)	TOTAL HT. (FT.)	TOP EL. (FT. MSL.)	BOTTOM EL. (FT. MSL.)	TOTAL HT. (FT.)
WASTE	20'-0"	2389.0	2037.5	351.5	1382.0	1286.0	96.0
AIR INTAKE	20'-3"	2397.0	2053.0	344.0	1389.5	1296.0	93.5
EXHAUST	15'-0"	2382.0	2042.0	340.0	1383.0	1285.0	98.0
SALT HANDLING	11'-10"	2386.0	2051.0	335.0	1391.0	1284.0	107.0

DETAIL
 SEE DRAWING FOR DETAILS
 NO SCALE



Albert W. Dennis
 9-2-76

REVISION	DATE	DESCRIPTION
1	10/20/23	ISSUED FOR PERMIT
2	10/20/23	ISSUED FOR PERMIT
3	10/20/23	ISSUED FOR PERMIT
4	10/20/23	ISSUED FOR PERMIT
5	10/20/23	ISSUED FOR PERMIT
6	10/20/23	ISSUED FOR PERMIT
7	10/20/23	ISSUED FOR PERMIT
8	10/20/23	ISSUED FOR PERMIT
9	10/20/23	ISSUED FOR PERMIT
10	10/20/23	ISSUED FOR PERMIT

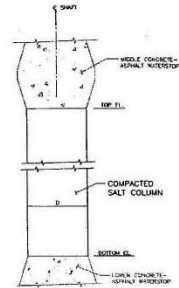

TABLE 1

SHAFT	NOMINAL SHAFT DIAMETER D	COMPACTED SALT COLUMN		
		TOP EL. (FT. MSG.)	BOTTOM EL. (FT. MSG.)	TOTAL HT. (FT.)
WASTE	20'-0"	1987.5	1432.0	555.5
AIR INTAKE	20'-3"	2003.0	1439.5	563.5
EXHAUST	15'-0"	1992.0	1435.0	559.0
SALT HANDLING	11'-10"	2001.0	1441.0	560.0

DETAIL
 SEE TABLE 1 FOR DETAILS
 NO SCALE
 DATE: 10/10/23
 SHEET: 25 OF 28



Albert W. Dennis
 9-2-76

DATE	10/10/23
BY	AWD
FOR	WIPP A/E SUPPORT
PROJECT NO.	WIPP A/E SUPPORT
PROJECT NAME	WIPP SHAFT SEALING SYSTEM
PROJECT LOCATION	COMPACTED SALT COLUMN
PROJECT NUMBER	100-100-100-100
PROJECT DATE	10/10/23
PROJECT SCALE	AS SHOWN
PROJECT SHEET NO.	25 OF 28

WIPP Shaft Sealing System Concrete Plug

Drawing SNL 007 26 of 28 not currently available. Drawing is not displayed in the Permit.

WIPP Shaft Sealing System Plug

Sheet 26 of 28

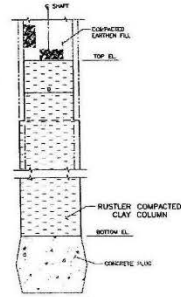

TABLE 1

SHAFT	NOMINAL SHAFT DIAMETER D	RUSTLER COMPACTED CLAY COLUMN		
		TOP EL. (FT. MSL)	BOTTOM EL. (FT. MSL)	TOTAL HT. (FT.)
WASTE	19'-0"	2836.0	2601.3	234.7
AIR INTAKE	16'-0"	2840.0	2005.3	234.7
EXHAUST	14'-0"	2829.0	2594.5	234.5
SALT HANDLING	10'-0"	2830.0	2596.0	234.0



Albert W. Dennis
 7-9-96

DETAIL
 SEE TABLE FOR DETAILS
 BY SCALE
 1/8" = 1'-0"
 1/4" = 1'-0"
 1/2" = 1'-0"
 3/4" = 1'-0"
 1" = 1'-0"

NO.	DATE	DESCRIPTION	BY	CHECKED
1	8/1/94	ISSUED FOR RECORDING PURPOSE	AWD	AWD
2	8/1/94	REVISION	AWD	AWD
SANDIA NATIONAL LABORATORIES				
WIPP A/E SUPPORT				
WIPP SHAFT SEALING SYSTEM				
RUSTLER COMPACTED CLAY COLUMN				
APPROVED	DATE	BY	DATE	BY

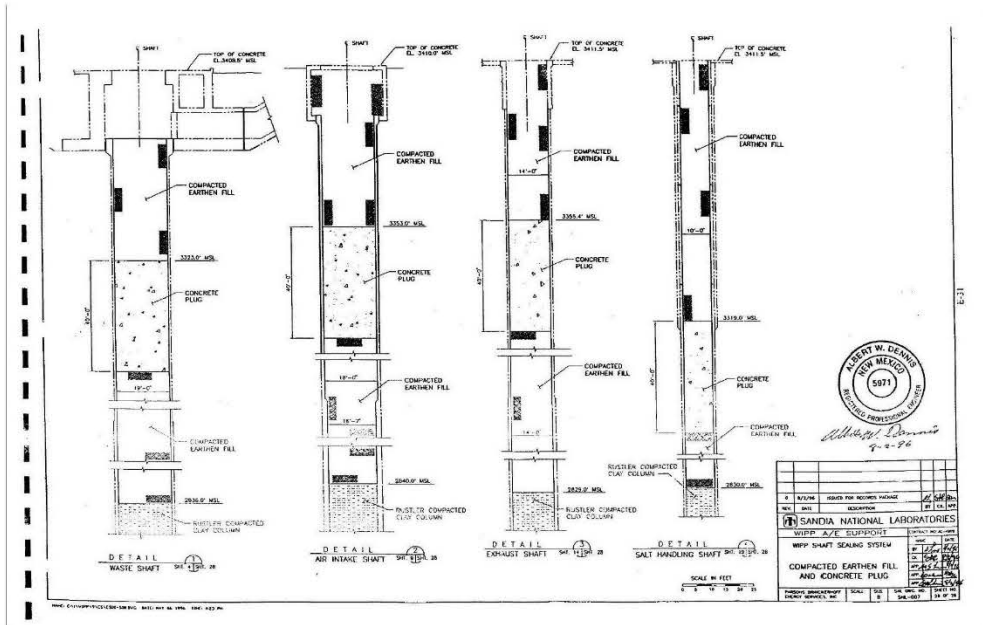

Compacted Earthen Fill and Concrete Plug

WASTE ISOLATION PILOT PLANT
CARLSBAD, NM
SHAFT SEALING SYSTEM DESIGN
EQUIPMENT AND CONSTRUCTION SKETCHES

DRAWING NUMBER	TITLE
SKETCH E-1	WPP SHAFT SEALING SYSTEM SMALLER GALLOWAY GENERAL ARRANGEMENT PLANS AND SECTIONS
SKETCH E-2	WPP SHAFT SEALING SYSTEM LARGER GALLOWAY GENERAL ARRANGEMENT PLANS AND SECTIONS
SKETCH E-3	WPP SHAFT SEALING SYSTEM TYPICAL HEADFRAME PLANS AND SECTIONS
SKETCH E-4	WPP SHAFT SEALING SYSTEM PERSPECTIVE HEADFRAME AND ASSOCIATED SURFACE FACILITIES

E-2

List of Sketches

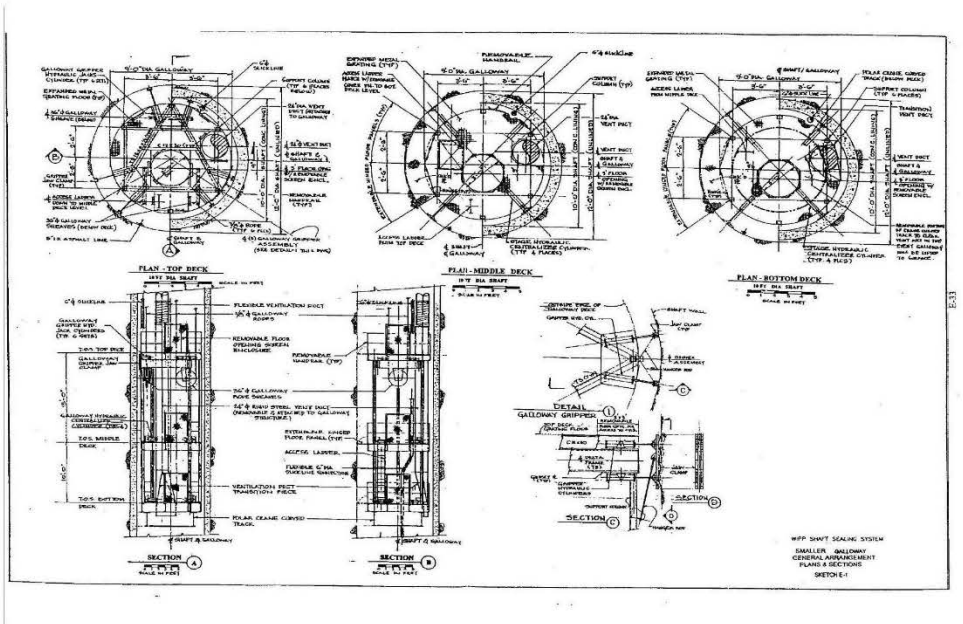

WIPP Shaft Sealing System Smaller Galloway Genral Arrangement Plans and Sections

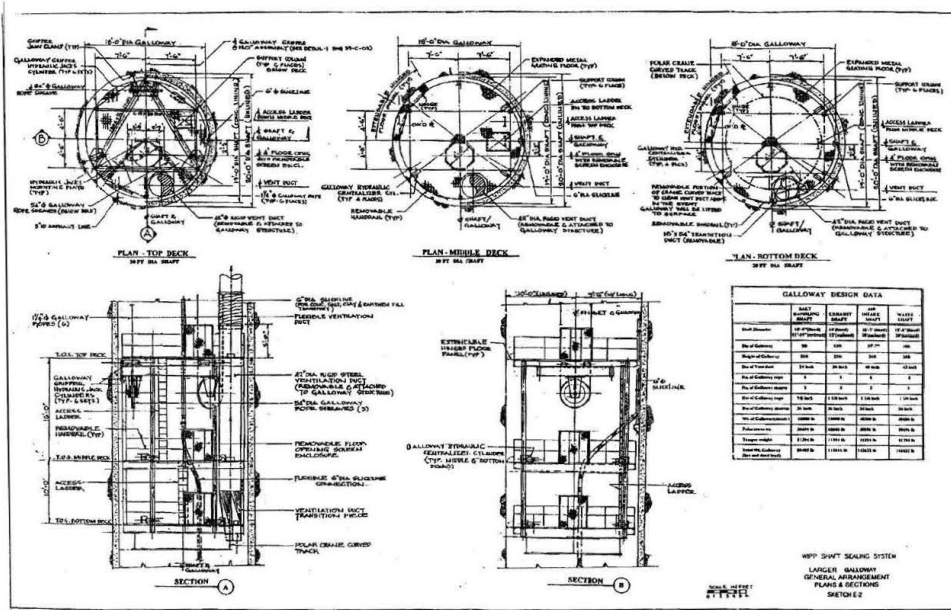

WIPP Shaft Sealing System Larger Galloway General Arrangement Plans and Sections

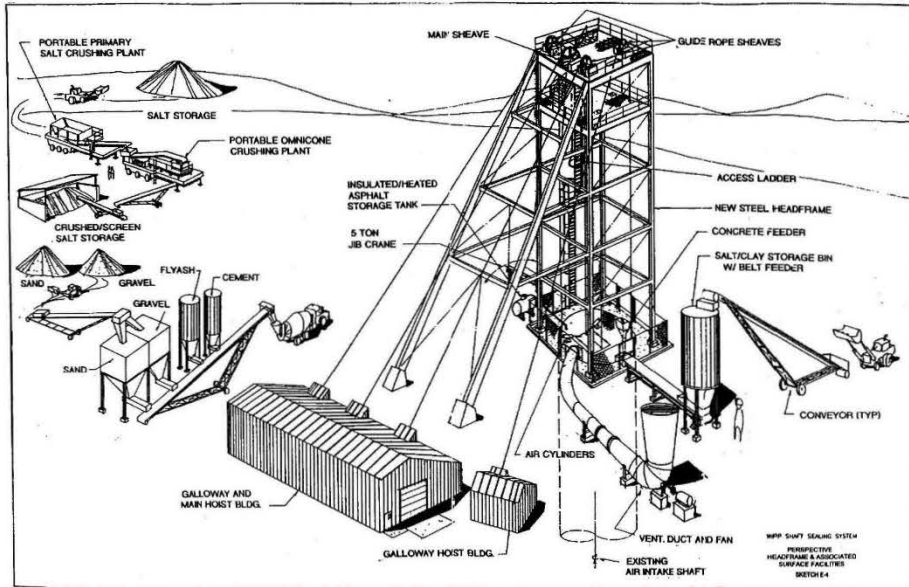

WPP Shaft Sealing System Typical Headframe and Associated Surface Facilities

WIPP
 UC721 Distribution List

Federal Agencies

US Department of Energy (4)
 Office of Civilian Radioactive Waste Mgmt.
 Attn: Deputy Director, RW-2
 Acting Director, RW-10
 Office of Human Resources & Admin.
 Director, RW-30
 Office of Program Mgmt. & Integ.
 Director, RW-40
 Office of Waste Accept., Stor., & Trans.
 Forrestal Building
 Washington, DC 20585

Attn: Project Director (2)
 Yucca Mountain Site Characterization Office
 Director, RW-3
 Office of Quality Assurance
 101 Convocation Center Drive, Suite #P-110
 Las Vegas, NV 89199

US Department of Energy
 Albuquerque Operations Office
 Attn: National Atomic Museum Library
 P.O. Box 5400
 Albuquerque, NM 87185-5400

US Department of Energy
 Research & Waste Management Division
 Attn: Director
 P.O. Box E
 Oak Ridge, TN 37831

US Department of Energy (5)
 Carlsbad Area Office
 Attn: G. Dialo
 D. Galbreath (3)
 M. Matthews
 M. McFadden
 R. Lark
 J. A. Mewhinney
 P.O. Box 3090
 Carlsbad, NM 88221-3090

US Department of Energy
 Office of Environmental Restoration and
 Waste Management
 Attn: J. Lytle, EM-10
 Forrestal Building
 Washington, DC 20585-0002

US Department of Energy (2)
 Office of Environmental Restoration and
 Waste Management
 Attn: M. Frei, EM-14, Trevino II
 Washington, DC 20585-0002

US Department of Energy
 Office of Environmental Restoration and
 Waste Management
 Attn: S. Schneider, EM-342, Trevino II
 Washington, DC 20585-0002

US Department of Energy (2)
 Office of Environment, Safety & Health
 Attn: C. Bergstrom, ES-25
 R. Pelletier, ES-23
 Washington, DC 20585

US Department of Energy (2)
 Idaho Operations Office
 Fuel Processing & Waste Mgmt. Division
 785 DOE Place
 Idaho Falls, ID 83402

US Environmental Protection Agency (2)
 Radiation Protection Programs
 Attn: M. Oge
 ANR-460
 Washington, DC 20460

Boards

Defense Nuclear Facilities Safety Board
 Attn: D. Winters
 625 Indiana Ave. NW, Suite 700
 Washington, DC 20004

Nuclear Waste Technical Review Board (2)
 Attn: Chairman
 S. J. S. Parry
 1100 Wilson Blvd., Suite 910
 Arlington, VA 22209-2297

State Agencies

Attorney General of New Mexico
 P.O. Drawer 1508
 Santa Fe, NM 87504-1508

Environmental Evaluation Group (3)

Attn: Library
 7007 Wyoming NE, Suite F-2
 Albuquerque, NM 87109

Metropolitan Water District of Southern Calif.
 Attn: J. Narvalz
 P.O. Box 54152
 Los Angeles, CA 90071-3123

NM Energy, Minerals, and Natural
 Resources Department
 Attn: Library
 2040 S. Pacheco
 Santa Fe, NM 87505

NM Environment Department (3)
 Secretary of the Environment
 Attn: Mark Welder
 1190 S. Francis Drive
 Santa Fe, NM 87503-0968

NM Bureau of Mines & Mineral Resources
 Socorro, NM 87901

NM Environment Department
 WIPP Project Site
 Attn: P. McCreeland
 P.O. Box 3690
 Carlsbad, NM 88221

Laboratories/Cooperations

Battelle Pacific Northwest Laboratories (2)
 Attn: R. E. Westerman
 R. Roman, MS P8-34
 P.O. Box 999
 900 Battelle Blvd
 Richland, WA 99352

Brookhaven National Laboratory
 Attn: P. D. Moskowitz
 Environmental & Waste Technology
 Center

Building 430
 Upton, NY 11973

Hansford/Gen Corp.
 Fluores Engineering Services
 Attn: R. Laebke
 7969 S. Chase Avenue
 Milwaukee, WI 53207-6401

Ian Clelland
 4656 N. Amalham Dr.
 Tucson, AZ 85704

INTERA, Inc.

Attn: G. A. Frooms
 1650 University Blvd. NE, Suite 300
 Albuquerque, NM 87102

INTERA, Inc. (6)
 Attn: J. F. Pickens
 V. Kelley
 M. Barnes
 W. Stachem
 J. Beach
 D. Fryer
 INTERA WIPP Library
 6850 Admin Center Blvd., Suite 300
 Austin, TX 78731

INTERA, Inc.
 Attn: J. Lee, YMP PA Dept.
 1261 Town Center Drive
 Las Vegas, NV 89134

INTERA, Inc.
 Attn: W. Starnad
 P.O. Box 2123
 Carlsbad, NM 88221

Innova Consulting Group, Inc.
 Attn: John Timoci
 Thrasher Square East
 708 South Third Street, Suite 210
 Minneapolis, MN 55415

Los Alamos National Laboratory
 Attn: B. Edgel, DMC-12
 P.O. Box 1663
 Los Alamos, NM 87544

Morcon International, Morcon Salt
 Attn: H. W. Diamond
 Morcon International Building
 100 N. Riverside Plaza,
 Randolph Street at the River
 Chicago, IL 60606-1597

Parsons Brinckerhoff Energy Services, Inc.
 Attn: W. S. Roman
 One Penn Plaza
 New York, NY 10119

Parsons Brinckerhoff Energy Services, Inc. (2)
 Attn: B. W. Lawrence
 C. D. Mann
 M. S. Liu
 303 Second Street
 Suite 810 North
 San Francisco, CA 94107

Distributions - 1

Waste Isolation Pilot Plant
 Hazardous Waste Facility Permit
 Attachment G2, Appendix G2-E
 October 2023

Parsons Brinckerhoff International, Inc.
 Attn: Mary Ann Novak
 700 11th Street, NW, Suite 710
 Washington, DC 20001

Phillips Mining, Geological & Georing
 Attn: Stephen Phillips
 8640 Herb Cleburne Place
 Tucson, AZ 85704

RESPEC, Inc. (5)
 Attn: L. Van Sankstek (3)
 G. Callahan
 M. Loken
 J. Raigien
 T. Ploffe
 324 4th Drive
 P.O. Box 725
 Rapid City, SD 57709

RESPEC, Inc.
 Attn: Angus Robb
 4775 Indian School NE, Suite 300
 Albuquerque, NM 87116-3927

Science Applications International Corp.
 Attn: W. Thompson
 15000 W. 6th Avenue, Suite 202
 Golden, CO 80401

Tech Apps, Inc. (3)
 Attn: J. Chapman (1)
 L. Reblinda (2)
 5000 Marble NE, Suite 222
 Albuquerque, NM 87110

Westinghouse Electric Corporation (5)
 Attn: Libby
 J. Epstein
 J. Lee
 B.A. Howard
 R. Kelsman
 P.O. Box 2078
 Carlsbad, NM 88221

S. Cohen & Associates
 Attn: Bill Thayer
 1355 Beverly Road
 McLean, VA 22101

National Academy of Sciences,
 WIPP Panel

Howard Adir
 Olympe, Incorporated
 7327 Oak Ridge Highway
 Knoxville, TN 37931

Bob Andrews
 Board of Radioactive Waste Management
 GFR-56
 2101 Constitution Ave.
 Washington, DC 20418

Robbery C. Ewing
 Department of Geology
 University of New Mexico
 Albuquerque, NM 87131

Charles Fairhurst
 Department of Civil
 and Mineral Engineering
 University of Minnesota
 500 Pillsbury Dr. SE
 Minneapolis, MN 55455-0220

B. John Gerrick
 PLO Incorporated
 4590 MacArthur Blvd., Suite 400
 Newport Beach, CA 92660-2027

Leonard F. Konikow
 US Geological Survey
 43 National Center
 Reston, VA 22092

Carl A. Anderson, Director
 Board of Radioactive Waste Management
 National Research Council
 JA 456
 2101 Constitution Ave. NW
 Washington, DC 20418

Christopher G. Whipple
 ICF Kaiser Engineers
 1800 Harrison St., 7th Floor
 Oakland, CA 94612-3430

John O. Blomeste
 720 Chubbouse Way
 Knoxville, TN 37909

Sue B. Clark
 University of Georgia
 Savannah River Ecology Lab
 P.O. Drawer E
 Aiken, SC 29802

Konrad B. Krauskopf
 Department of Geology
 Stanford University
 Stanford, CA 94305-2115

Della Rey
 Pennsylvania State University
 217 Materials Research Lab
 Hastings Road
 University Park, PA 16802

David A. Waite
 City of Hill
 P.O. Box 91300
 Bellevue, WA 98009-2050

Thomas A. Zordon
 Zordon Associates, Inc.
 3807 Edinburg Drive
 Marysville, PA 15668

Universities

Harvey Mudd College
 Attn: M. Cardenas
 Department of Engineering
 Claremont, CA 91711

New Mexico State University
 Waste-management Education & Research
 Corporation.
 Attn: B. Rhada
 P.O. Box 3083
 Las Cruces, NM 88003-8001

University of California
 Department of Mechanical and Environmental
 Engineering
 Attn: E. Marshall
 University of California
 Santa Barbara, CA 93106

University of Nevada-Reno
 Department of Mining Engineering
 Mackay School of Mines
 Attn: J. Dawson
 Reno, NV 89557

University of New Mexico
 Center for Radioactive Waste Management
 Attn: W. Lister
 209 Fels Engineering Building
 Albuquerque, NM 87131-1341

University of New Mexico
 Department of Civil Engineering
 Attn: J. C. Stormon
 Albuquerque, NM 87131-1351

University of New Mexico
 Geology Department
 Attn: Library
 141 Northrup Hall
 Albuquerque, NM 87131

University of Washington
 College of Ocean & Fishery Sciences
 Attn: G. R. Heath
 583 Henderson Hall, NW-15
 Seattle, WA 98195

Libraries

Thomas Bannigan Library
 Attn: D. DEMP
 366 W. Hadley St.
 Las Cruces, NM 88001

Government Publications Department
 Zimmerman Library
 University of New Mexico
 Albuquerque, NM 87131

New Mexico Junior College
 Powell Library
 Attn: R. Hill
 Lovington Highway
 Hobbs, NM 88240

New Mexico State Library
 Attn: N. McCallan
 325 Don Gaspar
 Santa Fe, NM 87503

New Mexico Tech
 Maria Spores Memorial Library
 Campus Street
 Socorro, NM 87810

WIPP Public Reading Room
 Carlsbad Public Library
 101 S. Hagadone St.
 Carlsbad, NM 88220

Foreign Addresses

Atomic Energy Canada Ltd. (5)
 Whiteshell Laboratory
 Attn: Neil Chamberlay
 Glen McCrack
 B. Goodwin
 Malcolm Gray
 Maria Onofrei
 Paines Manitoba, CANADA ROE 1L0

Distribution 2

Waste Isolation Pilot Plant
 Hazardous Waste Facility Permit
 Attachment G2, Appendix G2-E
 October 2023

Organization	MS	Org.	Internal
Francis Chacovier (2) ANDRA Route de Panorana Robert Schumann U. P. 38 F2266 Fontenay-aux-Roses, Cedex FRANCE			
Claude Sombret Centre d'Etudes Nucleaires de la Vallee Rhone CENVALRHO S.D.H.A. B.P. 171 30201 Bagnols-Sur-Ceze, FRANCE			
Commissariat a L'Energie Atomique Atm: D. Alexandre Centre d'Etudes de Cadarache 11108 Saint Paul Les Drennes Cedex FRANCE			
Bundesanstalt für Geowissenschaften und Kohle (2) Atm: M. Langer M. Wallner Postfach 510 153 D-30631 Hannover, GERMANY			
Bundesministerium für Forschung und Technologie Postfach 806 106 3300 Bonn 2, GERMANY			
Forschungszentrum Karlsruhe GmbH Institut für Nukleare Energiewirtschaft Atm: E. Korhous Postfach 3640, D-76021 Karlsruhe Bundesrepublik Deutschland GERMANY			
Gesellschaft für Anlagen und Reaktorsicherheit (GRS) Atm: B. Baltes Schwergasse 1 D-50667 Cologne, GERMANY			
Grundbau und Feldbau GmbH Atm: W. Wäke Herzestraße 50 50673 Aachen, GERMANY			
Institut für Gebirgsmechanik Atm: W. Winkler Friedrichstraße 60 04179 Leipzig, GERMANY			
Institut für Tieftragung Atm: K. Kuhn Theodor-Lieszt-Strasse 4 D-3300 Braunschweig, GERMANY			
Shiga Tsukuba Japan Atomic Energy Research Institute Tokai-Mura, Ibaraki-Ken, 319-11 JAPAN			
Netherlands Energy Research Foundation ECN Atm: J. Puij 3 Westerduinweg P.O. Box 1 1752 ZG Petten THE NETHERLANDS			
Universiteit Utrecht Department of Geology (HPT-lab) Atm: C. J. Spiers PO Box 80021 NL-3508 TA Utrecht Boulevard 4 THE NETHERLANDS			
Svensk Kärnbränsleforsörjning AB Atm: F. Karlsson Project KBS (Kärnbränsleäkerhet) Box 5164 S-102 48 Stockholm SWEDEN			
Nationale Genossenschaft für die Lagerung Radioaktiver Abfälle (2) Atm: S. Vovrova P. Zulkarna Hardenstrasse 73 CH-5430 Wetztingen SWITZERLAND			
AEA Technology Atm: J. H. Rees DOW79 Culham Laboratory Abingdon, Oxon OX14 3DB UNITED KINGDOM			
AEA Technology Atm: W. R. Redwell 944/A31 Winfrith Technical Centre Dorchester, Dorset DT2 8DH UNITED KINGDOM			
AEA Technology Atm: J. E. Timson 84244 Harwell Laboratory Didcot, Oxon OX11 0RA UNITED KINGDOM			
	0483	2165	R. E. Stinebaugh
	0706	6113	J. K. Lass
	1320	6719	E. J. Nowak
	1322	6121	J. R. Tillerson (10)
	1322	6121	E. H. Ahrens (2)
	1322	6121	A. W. Dennis (16)
	1322	6121	F. D. Hansen
	1322	6121	L. D. Harada
	1322	6121	M. K. Kavelos
	1324	6115	P. B. Davies
	1325	6832	L. S. Costin
	1325	6832	R. E. Finsky
	1328	6749	D. R. Anderson
	1328	6749	H. N. Jow
	1328	6849	M. F. Powell
	1328	6849	P. Vaughan
	1335	6705	M. Chu
	1341	6748	J. T. Holmes
	1395	6900	L. Shephard
	1395	6707	M. Marletta
	1395	6841	V. H. Shobonovics
	1330	6752	B. J. Pierson (2)
	1330	6752	NWML Library (100)
	5018	6323-2	Central Technical Files
	6899	4414	Technical Library (5)
	0619	12630	Review and Approval Desk, For DOBOSTI (2)

Distribution - 3

ATTACHMENT G3

**RADIOLOGICAL SURVEYS TO INDICATE POTENTIAL HAZARDOUS WASTE
RELEASES**

ATTACHMENT G3

RADIOLOGICAL SURVEYS TO INDICATE POTENTIAL HAZARDOUS WASTE RELEASES

TABLE OF CONTENTS

G3-1	Purpose	3
G3-2	Definition.....	3
G3-3	Discussion	3
	G3-3a Nature of the Hazardous Waste Portion of TRU Mixed Waste	3
	G3-3b Nature of the TRU Mixed Waste	4
	G3-3c Nature of the Releases.....	5
G3-4	Application of Radiological Surveys.....	5
	G3-4a TRU Mixed Waste Processing	6
	G3-4b TRU Mixed Waste Releases.....	6
	G3-4c Decontamination Activities at Closure	6

LIST OF TABLES

Table	Title
Table G3-1	Summary of Waste Generation Processes and Waste Forms
Table G3-2	Radiological Surveys During CH TRU Mixed Waste Processing (TRUPACT-II/HalfPACT)
Table G3-2a	Radiological Surveys During CH TRU Mixed Waste Processing (TRUPACT-III)
Table G3-3	Radiological Surveys During RH TRU Mixed Waste Processing

ATTACHMENT G3

RADIOLOGICAL SURVEYS TO INDICATE POTENTIAL HAZARDOUS WASTE RELEASES

G3-1 Purpose

Within the Resource Conservation and Recovery Act (RCRA) Permit for the Waste Isolation Pilot Plant (WIPP), detection of radiological contamination on surfaces is used to indicate whether a potential release of hazardous constituents has occurred. This method is used in addition to the visual examinations and container inspections mandated by the Permit.

G3-2 Definition

This Permit Attachment describes the principle of co-detection. Co-detection is defined as the process of identifying hazardous waste releases from containers of transuranic (TRU) mixed waste by performing radiological surveys on surfaces and assuming the release of a radioactive constituent indicates the concurrent release of a hazardous waste constituent. Co-detection does not apply to the gaseous release of volatile organic compounds (VOC) from TRU mixed waste containers nor does it apply to the detection of radioactive constituents in water. Radiological surveys are used to indicate the potential presence or absence of hazardous waste constituents based on the presence or absence of radioactive constituents on surfaces. Radiological surveys do not provide an assessment with regard to the concentrations of hazardous waste constituents since these surveys do not actually detect hazardous waste constituents.

G3-3 Discussion

Radiological surveys provide the Permittees with a very sensitive method of indicating the potential spill or release of hazardous waste constituents through the use of surface sampling (swipes) and radioactivity counting. This approach depends on the nature of the hazardous waste portion of the TRU mixed waste, the nature of the TRU mixed waste, and the nature of the spill or release. The sections below discuss each of these factors.

G3-3a Nature of the Hazardous Waste Portion of TRU Mixed Waste

The hazardous waste constituents in TRU mixed waste are mainly U.S. Environmental Protection Agency (EPA) F-coded solvents and metals that exhibit the toxicity characteristic. The TRU mixed wastes that are to be shipped to the WIPP facility for disposal have been placed into waste categories based on their physical and chemical properties. Waste category information is summarized in Table G3-1 with emphasis on the process that generated the waste. The waste generating processes can be described in five general categories:

1. Wastes (such as combustible waste) that result from cleaning and decontamination activities in which items such as towels and rags become contaminated simultaneously with hazardous and radioactive constituents. In these cases, the hazardous constituent and the radioactive constituent are intimately mixed, both on the rag or towel used for cleaning and as residuals on the surface of the object being cleaned. These waste forms

are not homogeneous in nature; however, they are generated in a fashion that distributes the hazardous and radioactive contaminants throughout the waste matrix.

2. Wastes generated when materials that contain metals that exhibit the toxicity characteristic become contaminated with radioactive constituents as the result of plutonium operations (leaded rubber, some glass, and metal waste are typical examples). These materials may also become contaminated with solvents during decontamination or plutonium recovery activities.
3. A class of processes where objects that are not metals are used in plutonium processes and become contaminated with radioactive constituents. They are subsequently cleaned with solvents to recover plutonium. Surfaces of these objects (such as graphite, filters, and glass) may be contaminated with both radioactive constituents and hazardous constituents.
4. Waste generating processes involving foundry operations where impurities are removed from plutonium. These impurities may result in the deposition of toxicity characteristic metals on the surfaces of objects, such as firebrick, ceramic crucibles, pyrochemical salts, and graphite, which are contaminated with residual quantities of radioactive constituents.
5. In all of the process waste categories in the second half of Table G3-1, the hazardous constituent and the radioactive constituents are physically mixed together as a result of the treatment process. In these wastes, the spill or release of the waste matrix may involve both the hazardous waste and the radioactive waste components, because the treatment process generates a relatively homogeneous waste form.

Based on the information in the attached table and the discussion above, hazardous constituent releases could potentially occur in either of two forms: 1) VOCs or 2) particulate resulting from the failure of the confinement capability of a container. Mechanisms that can initiate releases in these forms are discussed subsequently. Regardless of how the release occurs, the nature of the waste and the processes that generated it is such that the radioactive and hazardous components are assumed to be intimately mixed; a release of one without the other is not likely, except for releases of VOCs from containers.

G3-3b Nature of the TRU Mixed Waste

TRU mixed waste is defined as transuranic waste which is also a hazardous waste. The processes responsible for the radioactive constituents in the waste are, for the most part, the same processes responsible for making it a hazardous waste. Therefore, the TRU mixed waste forms are described in terms of both radioactive and hazardous waste. The Treatment, Storage, and Disposal Facility Waste Acceptance Criteria (**TSDF-WAC**) places limits on the characteristics of the waste that can be shipped to the WIPP facility based on the waste form. According to the TSDF-WAC, certain waste forms with specific characteristics are not allowed at the WIPP facility. Waste with liquid in excess of the TSDF-WAC limits is one waste form that is not allowed. Other limitations include, but are not limited to, a prohibition on pyrophoric materials, corrosive materials, ignitable waste, and compressed gases. Furthermore, payload containers of TRU waste must contain 100 nanocuries or more of transuranic elements per gram of waste, which means that the radioactive component of the waste will always be present within the waste in significant concentrations. The TSDF-WAC limitations and restrictions are

provided to ensure that any waste form received at the WIPP facility is stable and can be managed safely.

One benefit of waste form restrictions, such as no liquid in excess of the TSDF-WAC limits, is that they limit the kinds of releases that could occur to those that would be readily detectable through visual inspection (i.e., large objects that fall out of ruptured containers) or through the use of radiological detection either locally or within the adjacent area to detect materials that have escaped from containers.

G3-3c Nature of the Releases

The WIPP facility personnel will handle only sealed containers of TRU mixed waste and derived waste. The practice of handling sealed containers minimizes the opportunity for releases or spills. For the purposes of safety analysis (DOE 2018) ¹, it was assumed that releases and spills during operations occur by either of two mechanisms: 1) surface contamination and 2) accidents.

Radioactive materials releases resulting from unique and representative hazard evaluation events are documented in the WIPP Documented Safety Analysis (DSA) (DOE 2018). Surface contamination of a waste container is considered to be a credible source of contamination external to the containers during normal operations. Surface contamination is assumed to be caused by waste management activities at the generator site that result in the contamination of the outside of a waste container. Contamination would most likely be particulates (dirt or dust) that would be deposited during generator-site handling/loading activities. This contamination may not be detected by visible inspections. Surface contamination is detected after arrival at the WIPP facility through the use of swipes and radiation surveying equipment, as specified in radiological control procedures pursuant to 10 CFR Part 835. Surveying for radioactive constituents allows for the detection of contamination that may not be visible on the surface of the container. This exceeds the capability required by the RCRA, which is generally limited to inspections that detect only visible evidence of spills or leaks. RCRA-required inspections are specified in Permit Attachment E.

Releases due to accidents are modeled in the WIPP DSA. For the purposes of co-detection, releases are detectable using surface-contamination detection techniques.

G3-4 Application of Radiological Surveys

Radiological surveys apply to many situations calling for surveying to indicate the potential for releases. This includes initial sampling for surface radiological contamination upon receipt, sampling for contamination during waste handling activities, sampling for contamination during decommissioning, sampling for contamination during packaging for off-site shipment, and sampling to demonstrate the effectiveness of decontamination activities that follow a release or spill and retrieval. Radiological surveying is mandated by DOE Orders and provide an immediate indication of a radiological release or spill, even when there are no visibly detectable indications. A release or spill involving hazardous constituents will also likely involve a release or spill of radioactive constituents, based on the processes that generated the waste and the physical form of the waste. These processes mixed the hazardous and radioactive components,

¹ DOE 2018, Waste Isolation Pilot Plant Documented Safety Analysis, DOE/WIPP 07-3372, REV. 6a, February 2018.

as described in Table G3-1, to the extent that detection of the radioactive component can indicate the potential that the hazardous component is also present on a contaminated surface. Radiological surveys to indicate the potential for hazardous waste releases will be performed as specified in the following sections.

G3-4a TRU Mixed Waste Processing

Tables G3-2, G3-2a, and G3-3 specify the various steps in the process of receiving and disposing containers of CH TRU mixed waste, including RH TRU mixed waste in shielded containers and RH TRU mixed waste, respectively, where radiological surveys will be performed by the Permittees in accordance with radiological control procedures pursuant to 10 CFR Part 835.

G3-4b TRU Mixed Waste Releases

The RCRA Contingency Plan (Permit Attachment D) specifies actions required by the Permittees in the event of spills or leaking or punctured containers of CH and RH TRU mixed waste. Following completion of decontamination efforts, the Permittees will perform hazardous material sampling to confirm the removal of hazardous waste constituents from contaminated surfaces.

G3-4c Decontamination Activities at Closure

The Closure Plan (Permit Attachment G, Section G-1e(2)) specifies decontamination activities required by the Permittees at closure. Following completion of decontamination efforts, the Permittees will perform hazardous material sampling to confirm removal of hazardous waste constituents from contaminated surfaces.

Waste Isolation Pilot Plant
Hazardous Waste Facility Permit
Attachment G3
October 2023

TABLES

**Table G3-1
Summary of Waste Generation Processes and Waste Forms**

Waste Category	Hazardous Waste Codes	Description of Processes	Description of Waste Forms
Combustibles	F001, F002, F003, D008, D019	Cloth and paper wipes are used to clean parts and wash down gloveboxes. Wood and plastic parts are removed from gloveboxes after they are cleaned. Lead may occur as shielding tape or as minor noncombustible waste in this category.	Materials such as metals may retain traces of organics left on surfaces that were cleaned. Waste may remain on the cloth and paper that was used for cleaning or for wiping up spills.
Graphite		Graphite molds, which may contain impurities of metals, are scraped and cleaned with solvents to remove the recoverable plutonium.	Surfaces may retain residual solvents. Lead may be used as shielding or may be an impurity in the graphite.
Filters	F001, F002	Filters are used to capture radioactive particulate in air streams associated with numerous plutonium operations and to filter particulate from aqueous streams.	Filter media may retain organic solvents that were present in the air or liquid streams.
Benelex® and Plexiglas®	F001, F002, D008	Materials are used in gloveboxes as neutron absorbers. The glovebox assembly often includes leaded glass. All surfaces may be wiped down with solvents to remove residual plutonium.	Surfaces may retain residual solvents from wiping operations. Leaded glass may also be present.
Firebrick and Ceramic Crucibles	F001, F002, F005, D006, D007, D008	Firebrick is used to line plutonium processing furnaces. Ceramic crucibles are used in plutonium analytical laboratories. Both may contain metals as surface contaminants.	Metals deposited during plutonium refining or analytical operations could remain as residuals on surfaces. Surfaces may retain residual solvents.
Leaded Rubber	D008	Leaded rubber includes lead oxide impregnated materials such as gloves and aprons.	The leaded rubber could potentially exhibit the toxicity characteristic.
Metal	F001, F002, D008	Metals range from large pieces removed from equipment and structures to nuts, bolts, wire, and small parts. Many times, metal parts will be cleaned with solvents to remove residual plutonium.	Solvents may exist on the surfaces of metal parts. The metals themselves potentially exhibit the toxicity characteristic.
Glass	F001, F002, D006, D007, D008, D009	Glass includes Raschig rings removed from processing tanks, leaded glass removed from gloveboxes, and miscellaneous laboratory glassware.	Solvents may exist as residuals on glass surfaces and in empty containers. The leaded glass may exhibit the toxicity characteristic.
Inorganic Wastewater Treatment Sludge	F001-F003, D006-D009, P015	Sludge is vacuum filtered and stabilized with cement or other appropriate sorbent prior to packaging.	Traces of solvents and heavy metals may be contained in the treated sludge which is in the form of a solid dry monolith, highly viscous gel-like material, or dry crumbly solid.

Waste Isolation Pilot Plant
 Hazardous Waste Facility Permit
 Attachment G3
 October 2023

Waste Category	Hazardous Waste Codes	Description of Processes	Description of Waste Forms
Organic Liquid and Sludge	F001, F003	Organic liquids such as oils, solvents, and lathe coolants are immobilized through the use of various solidification agents or sorbent materials.	Solvents and metals may be present within the matrix of the solids created through the immobilization process.
Solidified Liquid	F001, F003, D006, D008	Liquids that are not compatible with the primary treatment processes and have to be batched. Typically these liquids are solidified with portland or magnesium cement.	Solvents and metals may be present within the matrix of the solids created through the immobilization process.
Inorganic Process Solids and Soil	F001, F002, F003, D008	Solids that cannot be reprocessed or process residues from tanks, firebrick fines, ash, grit, salts, metal oxides, and filter sludge. Typically solidified with portland or gypsum-based cements.	Solvents and metals may be present within the matrix of the solids created through the immobilization process.
Pyrochemical Salts	D007	Molten salt is used to purify plutonium and americium. After the radioactive metals are removed, the salt is discarded.	Residual metals may exist in the salt depending on impurities in the feedstock.
Cation and Anion Exchange Resins	D008	Plutonium is sorbed on resins and is eluted and precipitated.	Feed solutions may contain traces of solvents or metals depending on the preceding process.

**Table G3-2
 Radiological Surveys During CH TRU Mixed Waste Processing (TRUPACT-II/HalfPACT)**

Step in CH TRU Mixed Waste Processing	Surface Contamination Survey	Dose Rate Survey	Large Area Wipes ^a
Exterior of CH package after arrival at the WIPP facility	X	X	
CH package outer confinement assembly (OCA) lid interior and top of inner containment vessel (ICV) lid	X		X
CH package quick connect and vent port	X		
As ICV lid is raised		X	
ICV lid interior and top of payload	X		X
Payload assembly, guide tubes, standard waste box (SWB) and ten-drum overpack (TDOP) connecting devices	X		
As payload assembly is raised, including bottom of payload	X	X	
After placement of payload on facility pallet	X	X	X

^a Surface contamination surveys of CH packages are performed in accordance with radiological control procedures pursuant to 10 CFR Part 835.

Table G3-2a
Radiological Surveys During CH TRU Mixed Waste Processing (TRUPACT-III)

Step in CH TRU Mixed Waste Processing	Surface Contamination Survey	Dose Rate Survey	Large Area Wipes ^a
Exterior of TRUPACT-III after arrival at the WPP facility	X	X	
Interior of overpack cover and exterior of containment lid	X	X	X
TRUPACT-III vent port tool assembly quick connect	X		
Interior of containment lid and front of SLB2	X	X	X
As SLB2 is removed from TRUPACT-III		X	
After placement of SLB2 on facility pallet	X		X

^a Surface contamination surveys of CH packages are performed in accordance with radiological control procedures pursuant to 10 CFR Part 835.

**Table G3-3
 Radiological Surveys During RH TRU Mixed Waste Processing**

Step in RH TRU Mixed Waste Processing	Surface Contamination Survey	Dose Rate Survey
Exterior of cask after arrival at the WPP facility	X	X
After removal of impact limiters on RH-TRU 72-B cask	X	X
During removal of outer lid closure from RH-TRU 72-B cask	X	X
During removal of inner lid closure from RH-TRU 72-B cask	X	
During removal of upper impact limiter on the CNS 10-160B cask		X
After removal of upper impact limiter on the CNS 10-160B cask	X	X
After removal of the CNS 10-160B cask from the lower impact limiter	X	X
After transfer of the CNS 10-160B cask lid into the Hot Cell	X	
After transfer of waste drum carriages into the Hot Cell	X	
During transfer of waste into the facility canister in the Hot Cell	X	
During transfer of the waste canister from the RH-TRU 72-B cask to the facility cask	X	
Interior of shipping cask inside the RH Bay after unloading of waste canister or drums	X	
Exterior of shield plug subsequent to final canister emplacement		X
Interior of facility cask after completion of waste emplacement	X	

APPENDIX 3 – TRAINING PLAN (REFERENCED FROM ATTACHMENT F IN HWFP)

Waste Isolation Pilot Plant
Hazardous Waste Facility Permit
Attachment F
October 2023

**ATTACHMENT F
FACILITY PERSONNEL PERMIT TRAINING PROGRAM**

TABLE OF CONTENTS

F-0 Introduction.....3
F-1 Outline of the Facility Personnel Permit Training Program.....4
F-1a Facility Personnel Permit Training Program Design4
F-1b Job Title/Job Description5
 F-1b(1) Training Content6
 F-1b(2) Training Frequency6
 F-1b(3) Training Techniques.....6
F-1c Technical Training Manager (RCRA Training Director)7
F-1d Relevance of Training to Job Position.....8
F-2 Implementation of Facility Personnel Permit Training Program.....8
F-3 References.....9

LIST OF TABLES

Table	Title
Table F-1	TRU Mixed Waste Management and Emergency Response Job Titles and Descriptions
Table F-2	Permit-Required Training Courses

ATTACHMENT F

FACILITY PERSONNEL PERMIT TRAINING PROGRAM

F-0 Introduction

This attachment describes the *Facility Personnel Permit Training Program* for the Waste Isolation Pilot Plant (WIPP) facility in accordance with the requirements of the Resource Conservation and Recovery Act (RCRA) and the New Mexico Hazardous Waste Act as described in 20.4.1.500 New Mexico Administrative Code (NMAC) (incorporating Title 40 of the Code of Federal Regulations (CFR) §264.16), and 20.4.1.900 NMAC (incorporating 40 CFR §270.14(b)(12)).

The primary objective of the *Facility Personnel Permit Training Program* is to prepare facility personnel to operate and maintain the WIPP facility in a safe and environmentally sound manner in compliance with 20.4.1.500 NMAC (incorporating 40 CFR §264.16). To achieve this objective, the program provides WIPP facility employees with training relevant to their positions.

Waste Isolation Pilot Plant facility employees, including those not directly involved in transuranic (TRU) mixed waste handling activities or emergency response, receives an introduction to the RCRA regulations and emergency preparedness in their General Employee Training (GET) class. General Employee Training emphasizes that WIPP facility personnel and site visitors are required to comply with directions from emergency personnel and alarm system notifications and to follow instructions concerning emergency equipment, shutdown procedures, signage, and emergency evacuation routes and exits. In this way employees at the WIPP facility are given, at a minimum, a basic understanding of the regulatory requirements and emergency procedures. This ensures that facility employees know how to respond effectively to emergencies through familiarization with emergency procedures, emergency equipment, and emergency systems. Facility employees in TRU mixed waste management or emergency response positions receive additional classroom and on-the-job training designed specifically to teach them how to perform their duties safely and in conformance with regulatory requirements of 20.4.1.500 NMAC (incorporating 40 CFR Part 264). Transuranic mixed waste management personnel receive the required training before being allowed to work unsupervised, and emergency response personnel receive appropriate training before being called upon to respond to actual emergencies.

The training requirements of the *Facility Personnel Permit Training Program* are implemented via the WIPP Training Program and apply to appropriate facility personnel of the U.S. Department of Energy (DOE) and contractors, subcontractors, and bargaining-unit members who;

- Regularly work at the facility that may come in contact with and/or manage TRU mixed waste, or
- Oversee the operations of the facility that may come in contact with and/or manage TRU mixed waste, or

- Supervise individuals who may come in contact with and/or manage TRU mixed waste, or
- Provide emergency response capabilities.

This *Facility Personnel Permit Training Program* describes the introductory and continuing training provided to personnel at the WIPP facility, with emphasis on those facility personnel and their supervisors whose jobs are such that their actions or failure to act could result in a spill or release, or the immediate threat of a spill or release of TRU mixed waste.

This *Facility Personnel Permit Training Program* does not apply to facility employees who manage site-generated hazardous waste, low-level waste, universal waste, or other forms of hazardous waste that are not categorized as TRU mixed waste.

F-1 Outline of the Facility Personnel Permit Training Program

Employee training for the purpose of TRU mixed waste management and emergency response at the WIPP facility is the overall responsibility of the Management and Operating Contractor Project Manager, with responsibility for implementation delegated to Technical Training. Technical Training is managed by the Technical Training Manager. The Technical Training Manager (or designee) has the responsibility for directing the *Facility Personnel Permit Training Program*. The list of job titles in Table F-1 identifies the jobs at the WIPP facility that include responsibilities for TRU mixed waste management and emergency response.

F-1a Facility Personnel Permit Training Program Design

In developing the *WIPP Training Program*, Technical Training has used a modified version of the Systematic Approach to Training (SAT) which has five distinct phases to develop training programs. These phases are:

- Analysis
- Design
- Development
- Implementation
- Evaluation

Technical Training utilizes guidance provided within the DOE Handbooks, "Training Program Handbook: A Systematic Approach to Training (DOE-HDBK-1078-94)," and "Alternative Systematic Approaches to Training (DOE-HDBK-1074-95)" to direct these five phases.

Technical Training ensures that Permit-required training is conducted by qualified instructors as indicated in the *WIPP Training Program*.

Cognizant line managers provide significant input on training requirements for WIPP facility personnel to qualified instructors who develop the following, as required:

- Classroom Instruction
- Required reading, structured self-study, eLearning, computer-based training
- On-the-Job Training

Upon completion of the specific classroom, computer-based training, eLearning or structured self-study technical training courses, trainees must successfully complete written (includes in person examinations, computer, and web based training examinations) or oral examinations to demonstrate competency.

Technical training documentation and records are maintained by Technical Training located at the WIPP facility. Documents and records required by 20.4.1.500 NMAC (incorporating 40 CFR §264.16(d)(1), (2), (3), and (4) are maintained in WIPP facility files and include the following:

- Job titles for positions related to TRU mixed waste management and emergency response and names of the employee filling those positions
- Written job descriptions for the applicable positions
- Written description of the type and amount of introductory and continuing training given for each applicable position
- Records documentation that the training or job experience required has been given to or completed by facility personnel include as appropriate:
 - Course Attendance
 - Completed Qualification Cards
 - Off-Site Training Documentation
 - Training or job experience given and completed for each position

Documentation is maintained which includes records of training qualifications, and course attendance. The documentation is used to identify course refresher and requalification dates. Training records on current personnel are kept in the Technical Training files until facility closure. Technical training records on former employees are kept by Technical Training for at least three years from the date of employment termination from the WIPP facility. Training documentation for emergency response training received by personnel called out in the *RCRA Contingency Plan* (Permit Attachment D) is also maintained by Technical Training.

F-1b Job Title/Job Description

Facility personnel who are involved in TRU mixed waste management and emergency response activities receive the same core RCRA training. A list of TRU mixed waste management and emergency response job titles and position descriptions is provided in Table F-1. An up-to-date list of personnel assigned to these positions is maintained in WIPP facility files by the Permittees in accordance with 20.4.1.500 NMAC (incorporating 40 CFR §264.16(d)(1)). The core TRU mixed waste management and emergency response training courses are indicated in Table F-2. Any changes to the Facility Personnel Permit Training Program specified training course materials (contained in WIPP facility files) that affect the Table F-2 training course content will be evaluated to determine if a permit modification is required, as specified in 20.4.1.900 NMAC (incorporating 40 CFR §270.42). The job titles listed in Tables F-1 include:

- Emergency Coordinator
- TRU Mixed Waste Worker
- TRU Mixed Waste Worker Supervisor
- Inspector
- RCRA Training Director

- Emergency Responder

F-1b(1) Training Content

To ensure that facility personnel are knowledgeable in responding effectively to emergency situations, every employee, regardless of whether they hold a position in TRU mixed waste management or emergency response, receives GET and the annual GET refresher training on topics relevant to the management of TRU mixed waste and emergency response that include:

- Emergency Preparedness and Response
- RCRA (including the Permit and the RCRA Contingency Plan)
- Fire Protection
- Safety Signage

Training course updates are identified by periodically reviewing the Table F-2 Permit-required training courses to ensure the content remains consistent with applicable Federal and State regulations. This review will be performed in accordance with the *WIPP Training Program* and the review will be documented in the WIPP facility files.

To facilitate identification of changes to Table F-2 Permit-required training courses, changes to training course materials, which will be maintained in the WIPP facility files, will have revision numbers and a change history summary. This training course information will be available for NMED inspection upon request.

F-1b(2) Training Frequency

Transuranic mixed waste management and emergency response courses are offered at a frequency that ensures new hires or transfers can receive Permit-specified training within six months of assuming their new position. Annual refresher training is required for each Permit course. Employees do not work unsupervised in TRU mixed waste management positions until they have completed the Permit-required initial training. In cases where an employee's annual refresher training has lapsed, that employee cannot work unsupervised until the initial training has been repeated. The cognizant manager notifies the Human Resources Department who notifies the training staff when any employee is transferred into or out of a position associated with TRU mixed waste management or emergency response.

F-1b(3) Training Techniques

A variety of instructional techniques are used at the WIPP facility depending on the subject matter and the techniques that best suit the learning objectives. Many courses may include a combination of classroom, on-the-job training, computer-based training, eLearning, self-paced study, laboratory work, and/or comprehensive examinations. Most equipment operation courses include hands-on practical instruction.

Written examinations (includes in person examinations, computer, and web based training examinations) are used as a technique to test and document the knowledge level of individuals participating in classroom training courses. The length and content of each exam varies according to its objective. If individuals fail a written examination, in accordance with WIPP training procedures, they are disqualified from working unsupervised for the role or task

associated with the failed training until the training course examination has been successfully completed.

On-the-job training at the WIPP facility follows a prescribed set of standards specific to the job to be performed. Typically, to become qualified to operate a piece of equipment or system, employees must be able to demonstrate the location and purpose of specified controls and gauges, describe proper startup and shutdown procedures, describe specific safety features and limitations of the equipment, and, in some cases, perform maintenance functions. They must also demonstrate the ability to operate the equipment or system. On-the-job training may also be function specific, such as performing a specific administrative function that is regulated. The terms "on-the-job-training," "on-the-job-evaluation," and "job performance measures" are considered equivalent with respect to training courses or qualification cards in accordance with DOE-HDBK-1074-95.

In addition to on-the-job training, some positions require the trainee to attend an oral board. The oral board is given upon completion of on-the-job training and prior to operating any equipment unsupervised. In the oral board, the trainee is quizzed on knowledge learned in on-the-job training. The purpose of the oral board is to determine if the trainee fully understands and can apply the knowledge learned in the training process.

Individuals who provide evidence of equivalency for specific requirements or prerequisites identified in the Table F-2 Permit-required training courses may be granted an exception from further training to those requirements in accordance with the *WIPP Training Program*. Requests for exceptions/equivalences are made and evaluated in accordance with the *WIPP Training Program*. Training exceptions/equivalences must be approved by the RCRA Training Director with concurrence of the Environmental Compliance Manager or his/her designee. Each exception/equivalency request is evaluated per specific criteria, such as 1) completion of previous training (transcripts, training completion records), 2) previous experience (résumé) that demonstrates the application of knowledge and/or skills presented by course objectives, and 3) satisfactory completion of an examination having equivalent course objectives. Each exception/equivalency will be granted in writing and documented in the individual's training record.

F-1c Technical Training Manager (RCRA Training Director)

The Technical Training Manager (or designee) directs the *Facility Personnel Permit Training Program*, implemented via the *WIPP Training Program*, and is responsible for establishing technical training requirements in cooperation with the line managers. Specifically, this includes analysis, design, development, implementation, and evaluation of technical training. The Technical Training Manager (or designee) is trained in hazardous waste management procedures. The Technical Training Manager (or designee) is also required to be knowledgeable of the applicable regulations, orders, guidelines, and the specific training process employed at the WIPP facility.

The name and qualifications of the current Technical Training Manager are documented in WIPP facility files.

F-1d Relevance of Training to Job Position

The *WIPP Training Program* provides employees and their supervisors with training relevant to their positions. The SAT process mentioned in Section F-1a is a systematic method for determining the proper training for each TRU mixed waste management position. It compels managers and training staff to look critically at each position and determine the necessary training program for each employee to perform their work in a manner that protects human health and the environment and complies with the Permit.

Several training topics are considered relevant for all WIPP facility personnel. The basic philosophy at the WIPP facility is that, as a RCRA-regulated facility, facility personnel must understand the basic regulatory requirements under which the WIPP facility must operate as well as emergency actions required of facility personnel. Therefore, WIPP facility personnel receive an introduction to the RCRA during their GET.

Beyond these universal topics, training is designed and implemented relevant to the specific job functions being performed. For example, employees who operate key pieces of equipment necessary to manage contact-handled (CH) or remote-handled (RH) TRU mixed waste (e.g., forklifts, hoists, bridge cranes, cask transfer cars) must be trained to perform their duties in a way that ensures the WIPP facility is operated in compliance with the Permit. These employees receive on-the-job training and demonstrate the ability to operate the equipment, as appropriate, and must at a minimum be able to respond effectively to emergencies that might arise while performing their duties. Emergency response personnel receive training, commensurate with their duties, that ensures their familiarity with emergency procedures, emergency equipment, and emergency systems including, but not limited to:

- Procedures for using and inspecting facility emergency equipment;
- Communications and alarm systems; and
- Response to fires or explosions.

As there are no automatic waste feed systems at the WIPP facility, training on parameters for waste feed cut-off systems is not required. Similarly, as there is no potential for groundwater contamination incidents at the WIPP facility, training for responding to such incidents is not required.

F-2 Implementation of Facility Personnel Permit Training Program

The *WIPP Training Program* has been formulated to implement the requirements of this *Facility Personnel Permit Training Program*, thereby ensuring TRU mixed waste management and emergency response personnel employed at the facility receive the training necessary to comply with the requirements of 20.4.1.500 NMAC (incorporating 40 CFR Part 264.16).

Newly hired employees, whose job positions are listed in Table F-2, receive the indicated training within six months of their date of hire or their transfer to a new position pursuant to 20.4.1.500 NMAC (incorporating 40 CFR §264.16(b)). Personnel do not work unsupervised in TRU mixed waste management or emergency response positions until they successfully complete the Permit-indicated training requirements. TRU mixed waste management and emergency response personnel attend annual refresher courses that review the initial training received and document knowledge transfer. Per the *WIPP Training Program*, annual Permit

refresher training is to be completed within 30 calendar days of an employee's training anniversary date. If an employee's annual refresher training has lapsed, they do not work unsupervised in TRU mixed waste management or emergency response positions until they have successfully repeated the Permit-required initial training.

Records relating to the *Facility Personnel Permit Training Program* for TRU mixed waste management and emergency response personnel are maintained by WIPP Technical Training as personally identifiable information. These records are located at the WIPP facility and include a roster of employees in hazardous waste management positions; a list of courses required for each position; course descriptions; documentation when each employee has received and completed appropriate training. Training records of current personnel are kept by Technical Training until closure of the WIPP facility. Records of former employees are kept by Technical Training for at least three years from the date the employee last worked at the facility.

F-3 References

Nuclear Waste Partnership LLC, "WIPP Training Program," WP 14-TR.01

Nuclear Waste Partnership LLC, "WIPP Fire Department Training Plan," WP 12-FP.04

U.S. Department of Energy, "Training Program Handbook: A Systematic Approach to Training (DOE-HDBK-1078- 94)"

U.S. Department of Energy, "Alternative Systematic Approaches to Training (DOE-HDBK-1074 95)"

TABLES

**Table F-1
 TRU Mixed Waste Management and Emergency Response Job Titles and Descriptions**

JOB TITLE	POSITION DESCRIPTION
TRU Mixed Waste Worker	<p>Responsible for or involved in the surface processing, transport, and underground emplacement of CH and RH TRU mixed waste. May come into contact with TRU mixed waste while carrying out job duties, actions or failure to act could result in a spill or release of TRU mixed waste at the WPP facility, and job is important for operating the facility safely and in compliance with the hazardous waste regulations. Depending upon the TRU Mixed Waste Worker's specific job position, this may involve one or more of the following:</p> <ul style="list-style-type: none"> • Operating waste handling equipment and support systems to unload, handle, and emplace TRU mixed waste into the repository • Performing spot decontamination of shipping casks, waste containers, and waste handling equipment • Performing waste container overpacking operations • Conducting routine inspections of incoming shipping containers for contamination and damage • Conducting routine contamination surveys during waste handling activities • Operating the Waste Shaft Hoist • Loading and unloading of the Waste Shaft Conveyance above and below ground • Managing and dispositioning of waste resulting from releases of TRU mixed waste or TRU mixed waste constituents • Cleaning and restoring emergency response equipment after a release of TRU mixed waste or TRU mixed waste constituents and prior to resumption of normal operations
TRU Mixed Waste Worker Supervisor	<p>Supervisors of TRU Mixed Waste Workers are directly responsible for day-to-day operations related to TRU mixed waste. Depending upon the TRU Mixed Waste Worker Supervisor's specific job position, job duties may involve one or more of the following:</p> <ul style="list-style-type: none"> • Overseeing TRU mixed waste management activities performed by TRU Mixed Waste Workers • Coordinating and directing the daily operation and maintenance of the Waste Shaft Hoist and Waste Shaft
Emergency Responder	<p>Emergency responders provide expertise and support to the Incident Command. Depending upon the Emergency Responder's specific job position, job duties may involve one or more of the following:</p> <ul style="list-style-type: none"> • Responding to fires, explosions, or emergencies involving releases of TRU mixed waste or TRU mixed waste constituents • Performing technical rescue operations • Performing emergency medical response • Operating emergency vehicles and equipment • Establishing conditions at the incident scene • Managing incident operations, personnel, and resources • Ensuring that fires, explosions, and releases of TRU mixed waste do not occur, recur, or spread to other hazardous waste at the facility by stopping processes and operations, collecting and containing released TRU mixed waste, and removing or isolating containers, as applicable • Performing decontamination of contaminated personnel and providing oversight to emergency medical response personnel, if injured person is contaminated

JOB TITLE	POSITION DESCRIPTION
	<ul style="list-style-type: none"> • Conducting contamination surveys, establishing hot lines/cold zones, and performing decontamination following a release of TRU mixed waste or TRU mixed waste constituents • Overpacking or plugging/patching of waste containers associated with release of TRU mixed waste or TRU mixed waste constituents • Performing containerization of released TRU mixed waste or TRU mixed waste constituents • Terminating field emergency response
Emergency Coordinator	<p>In the event of a fire, explosion, release of TRU mixed waste or TRU mixed waste constituents that could threaten human health or the environment, the Emergency Coordinator is responsible for carrying out the implementation of the <i>RCRA Contingency Plan</i>. Emergency Coordinators ensure emergency responders have current and specific information to properly address the incident and minimize hazards to human health and the environment. Emergency Coordinators implement measures and procedures to ensure the safety of personnel, such as ensuring that alarms have been activated, personnel have been accounted for, and evacuation of personnel has occurred, if necessary. Upon implementation of the <i>RCRA Contingency Plan</i>, depending upon the Emergency Coordinator's specific job position, the job duties may involve one or more of the following:</p> <ul style="list-style-type: none"> • Providing notification to emergency response personnel • Ensuring that alarms have been activated, personnel have been accounted for, any injuries have been attended to, and evacuation of personnel has occurred, if necessary • Restricting personnel not needed for response activities from the scene of the incident and curtailing nonessential activities in the area • Identifying released material and assessing the extent of the emergency • Assessing any hazards to human health or the environment associated with a fire, explosion, or release of TRU mixed waste or TRU mixed waste constituents • Notifying appropriate State and local agencies with designated response roles if their help is needed • Ensuring that fires, explosions, and releases do not occur, recur, or spread to other hazardous waste at the facility by taking measures such as stopping processes and operations, collecting and containing released waste, and removing or isolating containers • Documenting the implementation of the <i>RCRA Contingency Plan</i> • Ensuring immediate notification to the New Mexico Environment Department is provided for incidents requiring implementation of the <i>RCRA Contingency Plan</i> • Making post-assessment notifications if it has been determined that the incident could threaten human health or the environment outside the facility • Providing for treating, storing, or disposing of recovered waste, contaminated soil or surface water, or any other material that results from a release, fire, or explosion at the facility • Ensuring that no waste that may be incompatible with the released material is treated, stored, or disposed of until cleanup procedures are completed • Ensuring that emergency equipment listed in the <i>RCRA Contingency Plan</i> is cleaned and fit for its intended use before operations are resumed

JOB TITLE	POSITION DESCRIPTION
Inspector	<p>Responsible for routine inspection and maintenance (including repairing and replacement, as appropriate) of equipment instrumental in preventing, detecting, or responding to environmental or human health hazards, such as monitoring equipment, safety and emergency equipment, and operating or structural equipment. Inspections are performed at the facility to detect malfunctions, deterioration, operator errors, and discharges that may cause or lead to releases of TRU mixed waste or TRU mixed waste constituents to the environment or that could be a threat to human health. Depending on the Inspector's specific job position, job duties may involve one or more of the following:</p> <ul style="list-style-type: none"> • Performing functional and operational checks of waste handling equipment and support systems as well as conducting waste container storage inspections • Conducting routine inspections of emergency response equipment and vehicles, on site • Performing routine inspections of the hoisting equipment for the Air Intake Shaft, Salt Handling Shaft, and Waste Shaft • Conducting routine inspections and testing of facility fire suppression and detection systems • Inspecting and testing of communication systems, site notification system, the public address system, and alarm systems for proper function • Performing routine inspections of the backup power supply diesel generators • Performing routine inspections of the eye wash and shower equipment • Performing routine inspections of the underground geomechanical instrumentation system • Performing routine inspections of the central uninterruptible power supply • Performing routine inspections of the fire water storage tank • Performing routine inspections of the ventilation exhaust fans
RCRA Training Director	<p>Responsible for directing the hazardous waste management training at the WIPP facility. To meet the 20.4.1.500 NMAC (incorporating 40 CFR §264.16(a)(2)) requirements, the RCRA Training Director must be a person trained in hazardous waste management procedures.</p>

Table F-2
Permit-Required Training Courses

Course	TRU Mixed Waste Worker	TRU Mixed Waste Worker Supervisor	Inspector	Emergency Responder	Emergency Coordinator	RCRA Training Director
General Employee Training – WIPP facility employees must be escorted at the WIPP facility until this course has been completed. Course content contains information on RCRA, the Permit, the WIPP <i>RCRA Contingency Plan</i> , emergency preparedness, emergency response and evacuation procedures, fire protection, and safety signage. There is an annual refresher required for this course.	X	X	X	X	X	X
RCRA Regulations/Hazardous Waste Facility Permit Overview – This course includes an overview of 40 CFR Parts 260-282; <i>New Mexico Hazardous Waste Act</i> (Title 20 of the NMAC, Part 4.1); protocol for facility and waste handling equipment inspections; overview of communication systems; overview of security systems; overview of <i>RCRA Contingency Plan</i> ; overview of WIPP emergency equipment use, inspection, and repair; overview of training requirements; overview of Permit recordkeeping requirements; overview of NMED facility inspections; and consequences of Permit noncompliance. This course also provides an overview of the screening process (for procedures, facility configuration changes, training program changes, etc.) to ensure compliance with the Permit, along with an overview of the Permit modification process. There is an annual refresher required for this course.	X	X	X	X	X	X

Course	TRU Mixed Waste Worker	TRU Mixed Waste Worker Supervisor	Inspector	Emergency Responder	Emergency Coordinator	RCRA Training Director
Hazardous Waste Worker – This course addresses regulatory requirements for personnel who manage hazardous waste, including an in-depth review of the Hazard Communication Standard, principles of toxicology, hazard identification, and an overview of personal protective equipment for work activities associated with TRU mixed waste management. It also prepares emergency response personnel for hazardous waste handling, containment, and decontamination. There is an annual refresher required for this course.	X	X		X		X
Hazardous Waste Responder – Employees must complete Hazardous Waste Worker training before taking this course. Upon successful completion of the course and its prerequisites, a trainee will be able to respond to emergencies involving TRU mixed waste. Course curriculum includes an overview of the regulatory requirements, incident evaluation, overview of response operations, maintaining safety during an emergency response, and an overview of the Incident Command System at the WIPP facility. There is an annual refresher required for this course.				X		
Hazardous Waste Worker Supervisor – This course addresses manager and/or supervisor responsibilities for TRU mixed waste management. It addresses individual and corporate liability under applicable hazardous waste regulations. Course discusses impacts that decisions made during emergency situations may have, some with serious legal and safety consequences directly impacting the entities involved. There is an annual refresher required for this course.		X				

Waste Isolation Pilot Plant
 Hazardous Waste Facility Permit
 Attachment F
 October 2023

Course	TRU Mixed Waste Worker	TRU Mixed Waste Worker Supervisor	Inspector	Emergency Responder	Emergency Coordinator	RCRA Training Director
<p>Permit Inspections/Recordkeeping – These technical work documents are under the purview of the responsible organization identified in Table E-1 of Permit Attachment E, <i>Inspection Schedule, Process and Forms</i>. This course addresses protocols for conducting Permit-specified inspections to detect malfunctions, deterioration, operator errors, and discharges; completion of inspection records; Permit-specified inspection frequencies; and corrective actions, including notifications and establishment of compensatory measures. This course also addresses review of the completed inspection record for completeness and accuracy; and the Permit-specified recordkeeping requirements. There is an annual refresher required for this course.</p>			X			
<p>RCRA Contingency Plan – This course provides an in-depth review of the WIPP <i>RCRA Contingency Plan</i> addressing when the Plan is to be implemented, appropriate emergency response actions, required notifications, evacuation plan details, and post-emergency RCRA-required activities. This course also addresses where copies of the Plan are required to be located and when the Plan must be amended. There is an annual refresher required for this course.</p>					X	

APPENDIX 4 – CONTINGENCY PLAN (REFERENCED FROM ATTACHMENT D IN HWFP)

Waste Isolation Pilot Plant
Hazardous Waste Facility Permit
Attachment D
October 2023

ATTACHMENT D RCRA CONTINGENCY PLAN TABLE OF CONTENTS

Introduction	4
D-1 Scope and Applicability.....	4
D-2 Emergency Response Personnel and Training.....	6
D-2a Emergency Response Personnel.....	6
D-2b Emergency Response Training.....	7
D-3 Criteria for Implementation of the <i>RCRA Contingency Plan</i>	8
D-4 Emergency Response Method	10
D-4a Immediate Notifications	10
D-4a(1) Initial Emergency Response and Alerting the RCRA Emergency Coordinator	10
D-4a(2) Communication of Emergency Conditions to Facility Employees	11
D-4b Identification of Released Materials and Assessment of the Extent of the Emergency.....	12
D-4c Assessment of the Potential Hazards	13
D-4d Post-Assessment Notifications.....	13
D-4e Control and Containment of the Emergency	15
D-4e(1) Fires	17
D-4e(2) Explosions	17
D-4e(3) Unplanned Sudden/Non-Sudden Releases	18
D-4e(4) Other Occurrences.....	19
D-4f Post-Emergency Activities	21
D-4f(1) Management and Disposition of Released Material	21
D-4f(2) Incompatible Waste.....	22
D-4f(3) Cleaning and Restoration of Equipment	22
D-5 Required Reporting.....	22
D-6 Emergency Equipment.....	23
D-7 Emergency Response Agreements.....	23
D-8 Evacuation Plan.....	24
D-8a Surface Evacuation On-site Assembly and Off-site Staging Areas	24
D-8b Underground Assembly Areas and Egress Hoist Stations.....	25
D-8c Plan for Surface Evacuation	25
D-8d Plan for Underground Evacuation.....	25
D-8e Further Site Evacuation.....	26

LIST OF TABLES

Table	Title
Table D-1	Resource Conservation and Recovery Act Emergency Coordinators ¹
Table D-2	Emergency Equipment Maintained at the Waste Isolation Pilot Plant

LIST OF FIGURES

Figure	Title
Figure D-1	WIPP Surface Structures
Figure D-1-NFB	WIPP Surface Structures with Building 416
Figure D-2	Spatial View of the WIPP Facility
Figure D-3	Underground Escape and Evacuation Map
Figure D-4	Fire-Water Distribution System
Figure D-4-NFB	Fire-Water Distribution System with Building 416
Figure D-4-S#5	Fire-Water Distribution System (with S#5)
Figure D-5	RH Bay Evacuation Routes
Figure D-6	RH Bay Hot Cell Evacuation Route
Figure D-7	Evacuation Routes in the Waste Handling Building
Figure D-8	WIPP Site Evacuation Map
Figure D-8a	WIPP Site Evacuation Routes

ATTACHMENT D

RCRA CONTINGENCY PLAN

Introduction

This attachment contains the *RCRA Contingency Plan* prepared in accordance with the Resource Conservation and Recovery Act (**RCRA**) requirements codified in 20.4.1.300 New Mexico Administrative Code (**NMAC**) (incorporating Title 40 of the Code of Federal Regulations (**CFR**) Part 262, Subpart M) and 20.4.1.500 NMAC (incorporating 40 CFR Part 264, Subpart D), "Contingency Plan and Emergency Procedures." The purpose of this document is to define responsibilities and to describe the coordination of activities necessary to minimize hazards to human health and the environment from fires, explosions, or any sudden or non-sudden release of hazardous waste, or hazardous waste constituents to air, soil, or surface water in accordance with 20.4.1.300 NMAC (incorporating 40 CFR §262.260(a)) and 20.4.1.500 NMAC (incorporating 40 CFR §264.51(a)). This plan consists of descriptions of emergency responses specific to contact-handled (**CH**) and remote-handled (**RH**) transuranic (**TRU**) mixed waste and site-generated hazardous waste handled at the WIPP facility.

Pursuant to 20.4.1.300 NMAC (incorporating 40 CFR §262.262(b)), the Permittees ensure that a copy of the *Quick Reference Guide to the WIPP Facility RCRA Contingency Plan* is maintained on file at the facility and is available to the emergency response organizations listed in Section D-2a, *Emergency Response Personnel*, and Section D-9, *Location of the RCRA Contingency Plan and Plan Revision*. Whenever the *RCRA Contingency Plan* is revised, the Permittees will update, if necessary, the quick reference guide and redistribute it in accordance with 20.4.1.300 NMAC (incorporating 40 CFR §262.262(c)).

D-1 Scope and Applicability

The regulated units at the WIPP facility subject to this permit include the hazardous waste management units (**HWMUs**) including the Waste Handling Building (**WHB**) Container Storage Unit (i.e., **WHB Unit**) and the Parking Area Container Storage Unit (i.e., **Parking Area Unit**), and the hazardous waste disposal units (**HWDUs**) in the underground disposal panels.

Pursuant to 20.4.1.500 NMAC (incorporating 40 CFR §264.51(a)), owners/operators of treatment, storage, and disposal facilities are required to have formal contingency plans in place that describe actions that facility personnel will take in response to any fire, explosion, or release of hazardous waste or hazardous waste constituents which could threaten human health or the environment. The contingency plan must meet the requirements of NMAC 20.4.1.500 NMAC (incorporating 40 CFR Part 264, Subpart D). The provisions of the *RCRA Contingency Plan* apply to HWDUs in the underground waste disposal panels, HWMUs in the WHB Unit and the Parking Area Unit, the Waste Shaft, and supporting TRU mixed waste handling areas. These areas are shown in Figures D-1 through D-3.

The WIPP facility is a large quantity generator of hazardous waste pursuant to 20.4.1.300 NMAC (incorporating 40 CFR Part 262, "Standards Applicable to Generators of Hazardous Waste"). 20.4.1.300 NMAC (incorporating 40 CFR §262.261(a)) requires that a contingency plan be in place that describes actions that facility personnel will take in response to any fire, explosion, or release of hazardous waste or hazardous waste constituents which could threaten

human health or the environment. The provisions of this *RCRA Contingency Plan* also apply to the site-generated hazardous waste accumulation areas (both the central accumulation areas (CAAs), also referred to as the less-than-90-day areas, and satellite accumulation areas (SAAs)), the locations of which are specified in the *Quick Reference Guide to the WIPP Facility RCRA Contingency Plan*. For the remainder of this document, the term "site-generated hazardous waste" will mean waste accumulated in both the CAAs and SAAs.

Wastes may also be generated at the WIPP facility as a direct result of managing the TRU and TRU mixed wastes received from the off-site generators. Throughout the remainder of this plan, this waste is referred to as "derived waste." Derived waste will be managed as TRU mixed waste and emplaced in the rooms in HWDUs along with the TRU mixed waste for disposal. Every reasonable effort to minimize the amount of derived waste, while providing for the health and safety of personnel, will be made.

Wastes generated as a result of emergency response actions will be categorized into one of three groups and disposed of accordingly. These are: 1) nonhazardous wastes to be disposed of at an appropriate disposal facility (e.g., low-level waste facility or approved landfill), 2) hazardous nonradioactive wastes (site-generated hazardous waste) to be disposed of at an off-site RCRA permitted facility, and 3) derived waste to be disposed of in the underground HWDUs as TRU mixed waste. Hazardous liquid wastes that may be generated as a result of emergency response actions will be managed as follows:

- Non-Mixed—Accumulated liquids contaminated only with hazardous constituents will be placed into containers and managed in accordance with 20.4.1.300 NMAC (incorporating 40 CFR §262.17) requirements. The waste will be shipped to an approved off-site treatment, storage, or disposal facility.
- Mixed—Accumulated liquids contaminated with TRU mixed waste will be solidified and the solidified materials will be disposed of in the underground WIPP repository as TRU mixed waste.

Waste containing liquid in excess of treatment, storage, or disposal facility Waste Acceptance Criteria (TSD-F-WAC) limits shall not be emplaced in the underground HWDUs (See Permit Attachment C, Section C-1c).

Off-site waste managed and disposed of at the WIPP facility is radioactive mixed waste, and as a result, response to emergencies must consider the dual hazard associated with this waste. In responding to emergencies involving TRU mixed waste, the actions necessary to protect human health and the environment from the effects of radioactivity may be similar to those actions necessary to provide protection from hazardous waste and hazardous waste constituents. Such responses may require the use of equipment and processes specific to events resulting in radiological contamination (e.g., continuous air monitors, decontamination shower equipment, HEPA vacuums, paint/fixatives) and are not included in the *RCRA Contingency Plan*. Furthermore, the *RCRA Contingency Plan* may require additional actions to be taken to mitigate the hazards associated with the hazardous component of the waste. These measures are not intended to replace actions required to protect human health and the environment in response to radiological emergencies. In this manner, the *RCRA Contingency Plan* complements the radiological response activities.

D-2 Emergency Response Personnel and Training

D-2a Emergency Response Personnel

A RCRA Emergency Coordinator will be on-site at the WIPP facility 24 hours a day, seven days a week, with the responsibility for coordinating emergency response measures. In accordance with 20.4.1.300 NMAC (incorporating 40 CFR §262.261(d)) and 20.4.1.500 NMAC (incorporating 40 CFR §264.52(d)), qualified RCRA Emergency Coordinators are listed in Table D-1 and are trained to the requirements found in Permit Attachment F, Table F-2, under "Emergency Coordinator."

Persons qualified to act as the RCRA Emergency Coordinator have the authority to commit the necessary resources to implement this *RCRA Contingency Plan*.

During emergencies, the RCRA Emergency Coordinator has three primary responsibilities:

- **Assess the Situation**—The RCRA Emergency Coordinator shall gather information relevant to the incident, such as the type of event, quantity and type of released waste, and existing or potential hazards to human health and the environment.
- **Protect Personnel**—The RCRA Emergency Coordinator shall take reasonable measures to ensure the safety of personnel, such as ensuring that alarms have been activated, personnel have been accounted for, any injuries have been attended to, and evacuation of personnel has occurred, if necessary.
- **Contain the Release**—The RCRA Emergency Coordinator shall take reasonable measures to ensure that fires, explosions, or releases of hazardous waste or hazardous waste constituents do not occur, recur, or spread.

In addition to the RCRA Emergency Coordinator, the following individuals, groups, and organizations have responsibilities during a WIPP facility emergency, which may include the following:

- **WIPP Fire Department**—The primary providers of fire suppression, technical rescue, Emergency Medical Services (EMS), and hazardous materials response for the protection of personnel in both surface and underground facilities. The WIPP Fire Department personnel serve as an Industrial Fire Brigade and are trained to respond to surface and underground emergencies on site, including fires, medical emergencies, and releases of hazardous materials.
- **Facility Shift Manager (FSM)**—A member of the Facility Operations organization who is in charge of plant operations and is the senior shift representative responsible for maintaining the facility in a safe configuration during normal and abnormal conditions. The FSM can concurrently serve as the RCRA Emergency Coordinator, if trained to the requirements of Permit Attachment F (*Facility Personnel Permit Training Program*) or provide support to the qualified RCRA Emergency Coordinator on shift.
- **Central Monitoring Room Operator (CMRO)**—An on-shift operator responsible for Central Monitoring Room (CMR) operations, including coordination of facility communications. The CMRO documents these activities (e.g., communications,

notifications) in a facility log. The CMRO is a member of Facility Operations, and during emergencies, the CMRO supports the RCRA Emergency Coordinator.

- Firefighter—A WIPP Fire Department member who serves as a primary responder to surface and underground emergencies, including fires, medical emergencies, and releases of hazardous materials. Firefighters assigned to the underground will not perform any coordinated firefighting underground and will only respond to incipient-stage fires that threaten TRU mixed waste, if it is safe to do so.
- Fire Department Incident Commander—Upon delegation by the RCRA Emergency Coordinator, and once incident command has been established, the Incident Commander is responsible for direction and supervision of emergency responders during an incident resulting in implementation of the *RCRA Contingency Plan*. The Incident Commander will be a member of the WIPP Fire Department. For security-related incidents that invoke implementation of the *RCRA Contingency Plan*, the Fire Department Incident Commander will establish a unified command with the WIPP Protective Force.
- Mine Rescue Team (MRT)— The MRT emergency response capabilities include search, rescue, reentry, and recovery operations. The MRT responds in accordance with the requirements of 30 CFR Part 49. The MRT emergency response actions include extinguishing incipient stage fires, if encountered, and immediately reporting uncontrolled fires.
- Emergency Operations Center (EOC) Staff- Upon activation, the EOC supports the RCRA Emergency Coordinator and Incident Commander with emergency management decision-making and associated notifications. Since EOC staff performs duties similar to their normal job functions during an emergency response and provides support related to their area(s) of expertise, no specific RCRA training is required.

D-2b Emergency Response Training

The WIPP Fire Department personnel are trained in accordance with the *WIPP Fire Department Training Plan*, which is kept on file at the WIPP facility. The training plan incorporates current National Fire Protection Association (NFPA) standards for training Firefighters.

Fire Department Incident Commanders are also trained in accordance with the *WIPP Fire Department Training Plan*, which incorporates the Federal Emergency Management Agency (FEMA), Incident Command System (ICS), and the National Incident Management System (NIMS) standards.

WIPP personnel who perform EMS duties are licensed through the State of New Mexico Emergency Medical Systems Bureau. Licensure requirements for training, continuing education, and skills maintenance are set forth through state requirements. Licenses are maintained by attending training seminars or conferences.

As described above, emergency response training is conducted in accordance with the *WIPP Fire Department Training Plan*, which is updated whenever the applicable standards are revised. In addition to the emergency response training, WIPP Fire Department personnel are

required to complete applicable site-specific training, which is described in Permit Attachment F, *Facility Personnel Permit Training Program*.

D-3 Criteria for Implementation of the RCRA Contingency Plan

The provisions of the *RCRA Contingency Plan* shall be implemented immediately whenever there is a fire, an explosion, or a release of hazardous wastes or hazardous waste constituents that could threaten human health or the environment, or whenever the potential for such an event exists as determined by the RCRA Emergency Coordinator, as required under 20.4.1.300 NMAC (incorporating 40 CFR §262.260(b)) and 20.4.1.500 NMAC (incorporating 40 CFR §264.51(b)).

There may be situations that do not readily lend themselves to an immediate assessment of the possible hazards to human health and the environment. In these cases, the RCRA Emergency Coordinator will implement the *RCRA Contingency Plan* as a precautionary measure, regardless of the emergency situation or occurrence, if the RCRA Emergency Coordinator has reason to believe that a fire, explosion, or release of hazardous waste or hazardous waste constituents has occurred that could threaten human health or the environment.

In accordance with 20.4.1.300 NMAC (incorporating 40 CFR §262.265(i)) and 20.4.1.500 NMAC (incorporating 40 CFR §264.56(i)), the RCRA Emergency Coordinator, on behalf of the Permittees, will record the time, date, and details of the incident that required implementation of the *RCRA Contingency Plan*. The Secretary of the NMED will be immediately notified by the Permittees. Additionally, the Permittees shall submit a written report to the NMED within 15 days of the incident, as specified in Section D-5. The following emergency situations, as they pertain to TRU mixed waste and generated hazardous wastes, warrant immediate implementation of the *RCRA Contingency Plan* by the RCRA Emergency Coordinator in accordance with standard operating procedures on file at the WIPP facility:

- Fires
 - If a fire involving TRU mixed waste or site-generated hazardous waste occurs
 - If a fire (e.g., building, grass, nonhazardous waste fire) occurs within or near a CAA or SAA that threatens to involve site-generated hazardous waste
 - If a fire (e.g., building, grass, nonhazardous waste fire) occurs within or near the permitted HWMUs that threatens to involve TRU mixed waste
 - If a fire occurs in the underground that results in immediate personnel evacuation or prevents normal personnel access to the underground

For any fire that does not meet the above criteria, the RCRA Emergency Coordinator shall document the rationale for not implementing the *RCRA Contingency Plan* (e.g., there is no threat to human health or the environment).

- Explosions
 - If an explosion involving TRU mixed waste or site-generated hazardous waste occurs

- If an explosion occurs within or near a CAA or SAA that threatens to involve site-generated hazardous waste
- If an explosion occurs within or near the permitted HWMUs that threatens to involve TRU mixed waste
- If an explosion occurs in the underground that results in immediate personnel evacuation or prevents normal personnel access to the underground
- If there is an imminent danger of an explosion occurring (e.g., gas leak with an ignition source nearby) which could involve TRU mixed or site-generated hazardous waste

For any explosion that does not meet the above criteria, the RCRA Emergency Coordinator shall document the rationale for not implementing the *RCRA Contingency Plan* (e.g., there is no threat to human health or the environment).

- **Unplanned Sudden/Non-Sudden Releases**
 - If, prior to waste emplacement, one or more containers of TRU mixed waste has spilled or been breached due to dropping, puncturing, container failure or degradation, or any other physical or chemical means, resulting in a release
 - If, after waste emplacement, one or more containers of TRU mixed waste in an active room has been breached
 - If a continuous air monitor confirms a release of radioactive particulates to the ambient atmosphere, indicating a possible release of TRU mixed waste constituents from the permitted facility
 - If a spill of site-generated hazardous waste occurs in a CAA or SAA and cannot be contained with secondary containment methods or absorbents, thereby threatening a release to air, soil, or surface water
 - If a site-generated hazardous waste spill occurs in a CAA or SAA and results in the release of potentially flammable material, thereby threatening to create a fire or explosion hazard
 - If a site-generated hazardous waste spill occurs in a CAA or SAA and results in the release of potentially toxic fumes that could threaten human health

For any release of hazardous waste or hazardous waste constituents that does not meet the above criteria, the RCRA Emergency Coordinator shall document the rationale for not implementing the *RCRA Contingency Plan* (e.g., there is no threat to human health or the environment).

- **Other Occurrences**

- If a natural phenomenon (e.g., earthquake, flood, lightning strike, tornado) occurs that involves TRU mixed waste or site-generated hazardous waste or threatens to involve TRU mixed waste or site-generated hazardous waste
- If an underground structural integrity emergency (e.g., roof fall in an active room) occurs that involves TRU mixed waste or site-generated hazardous waste, threatens to involve TRU mixed waste or site-generated hazardous waste, results in immediate personnel evacuation, or prevents normal personnel access to the underground

For any natural phenomenon or underground structural emergency that does not meet the above criteria, the RCRA Emergency Coordinator shall document the rationale for not implementing the *RCRA Contingency Plan* (e.g., there is no threat to human health or the environment).

D-4 Emergency Response Method

Methods that describe implementation of the *RCRA Contingency Plan* cover the following six areas:

1. *Immediate Notifications* (Section D-4a)
2. *Identification of Released Materials and Assessment of Extent of the Emergency* (Section D-4b)
3. *Assessment of the Potential Hazards* (Section D-4c)
4. *Post-Assessment Notifications* (Section D-4d)
5. *Control and Containment of the Emergency* (Section D-4e)
6. *Post-Emergency Activities* (Section D-4f)

D-4a Immediate Notifications

Notification requirements in the event of implementation of the *RCRA Contingency Plan* are defined by 20.4.1.300 NMAC (incorporating 40 CFR §262.265(a)) and 20.4.1.500 NMAC (incorporating 40 CFR §§264.56(a)). Personnel at the WIPP facility are trained to respond to emergency notifications.

Whenever an emergency situation occurs that warrants implementation of this *RCRA Contingency Plan*, as described in Section D-3, the Permittees will immediately notify the Secretary of the NMED.

D-4a(1) Initial Emergency Response and Alerting the RCRA Emergency Coordinator

The first person to become aware of an incident shall immediately report the situation to the CMRO and, as requested by the CMRO, provide the relevant information. Facility personnel are trained in the process for notifying the CMRO as part of General Employee Training (GET).

In addition to receiving incident reports from facility personnel, the CMRO monitors the status of alarms 24 hours a day, takes telephone calls and radio messages, initiates calls to emergency staff, and initiates emergency response procedures regarding evacuation, if needed.

Once the CMRO is notified of a fire, explosion, or a release anywhere in the facility (either by eyewitness notification or an alarm), the RCRA Emergency Coordinator is immediately notified. The RCRA Emergency Coordinator ensures that the emergency responders, including the WIPP Fire Department and the MRT, have been notified, as needed. Once incident command has been established, the RCRA Emergency Coordinator has the authority to delegate the responsibilities for mitigation of the incident to the Incident Commander.

The response to an unplanned event will be performed in accordance with standard operating procedures and guides based on the applicable federal, state, or local regulations and/or guidelines for that response. These include DOE Order 151.1D, *Comprehensive Emergency Management System*; the U.S. Mine Safety and Health Administration (MSHA); the NMAC; the Comprehensive Environmental Response, Compensation, and Liability Act; Chapter 74, Article 4B, New Mexico Statutes Annotated 1978; and the New Mexico Emergency Management Act.

If needed, the RCRA Emergency Coordinator will immediately notify the appropriate federal, state, and local agencies and mining companies in the vicinity of the WIPP facility, listed in Section D-7, with designated response roles.

Depending on the emergency, the EOC may be activated for additional support. In the event that the EOC is activated, decision-making responsibilities related to emergency management and associated notifications may be delegated to the EOC by the RCRA Emergency Coordinator. The EOC will assist in the mitigation of the incident with the use of appropriate communications equipment and technical expertise from available resources. During the emergency, the RCRA Emergency Coordinator will remain in contact with and advise the EOC of the known hazards.

The EOC staff assesses opportunities for coordination and the use of mutual-aid agreements with local agencies making additional emergency personnel and equipment available (Section D-7), as well as the use of specialized response teams available through various state and federal agencies. Because the WIPP facility is a DOE-owned facility, the Permittees may also use the resources available from the *National Response Framework*.

D-4a(2) Communication of Emergency Conditions to Facility Employees

Procedures for immediately notifying facility personnel of emergencies are as follows:

- Local Fire Alarms

The local fire alarms sound an audible tone and may be activated automatically or manually in the event of a fire.

- Surface Evacuation Signal

The evacuation signal is a yelp tone and is manually activated by the CMRO when needed. The CMRO follows the evacuation signal with verbal instructions and ensures the Site Notification System has been activated.

- **Underground Evacuation Warning System**

The underground evacuation signal is a yelp tone and flashing strobe light. In the event of an evacuation signal, underground personnel will follow escape routes to egress hoist stations. Underground personnel are trained to report to the underground assembly areas and await further instruction if power fails or if ventilation stops. If evacuation of underground personnel is required due to a power failure, a backup generator is available to power the hoisting equipment. Evacuation will be in accordance with the applicable requirements of MSHA.

WIPP facility personnel are trained and given instruction during GET to recognize the various alarm signals and the significance of each alarm. WIPP facility employees and site visitors are required to comply with directions from emergency personnel and alarm system notifications and to follow instructions concerning emergency equipment, shutdown procedures, and emergency evacuation routes and exits.

D-4b Identification of Released Materials and Assessment of the Extent of the Emergency

The identification of hazardous wastes or hazardous waste constituents involved in a fire, an explosion, or a release to the environment is a necessary part of the RCRA Emergency Coordinator's assessment of an incident, as described in 20.4.1.300 NMAC (incorporating 40 CFR §262.265(b)) and 20.4.1.500 NMAC (incorporating 40 CFR §264.56(b)). Immediately after alarms have been activated and required notifications have been made, the RCRA Emergency Coordinator shall direct an investigation to determine pertinent information relevant to the actual or potential threat posed to human health or the environment. The information will include the character, exact source, amount, and areal extent of any released material. This may be done by observation or review of facility records or manifests and, if necessary, by chemical analysis.

The identification of the character and source of released materials at any location is enhanced because hazardous wastes are stored, managed, or disposed at specified locations throughout the WIPP facility.

Sources of information available to identify the hazardous wastes involved in a fire, an explosion, or a release at the WIPP facility include operator/supervisor knowledge of their work areas, materials used, and work activities underway; the WIPP Waste Information System (WWIS), which identifies the location within the facility of emplaced TRU mixed waste, including emplaced derived waste; and waste manifests and other waste characterization information in the Operating Record. The WWIS also includes information on wastes that are in the waste handling process. Also available are Safety Data Sheets (SDSs) for hazardous materials in the various user areas throughout the facility, waste acceptance records, and materials inventories for buildings and operating groups at the WIPP facility. Information or data from the derived waste accumulation areas, the site-generated hazardous waste accumulation areas, and nonregulated waste accumulation areas are included. It is anticipated that this information is sufficient for identifying the nature and extent of the released materials. The RCRA Emergency Coordinator has access to this information when needed.

The waste received at the WIPP facility must meet the TSDF-WAC (e.g., no more than one percent liquid), which minimizes the possibility of waste container degradation and liquid spills. Should a spill or release occur from a container of site-generated hazardous or TRU mixed waste, following an initial assessment of the event, the RCRA Emergency Coordinator will

ensure that the following actions are immediately taken, consistent with radiological control procedures, in compliance with 20.4.1.300 NMAC (incorporating 40 CFR §262.261(a)) and 20.4.1.500 NMAC (incorporating 40 CFR §264.52(a) and §264.171):

- Assemble the required response equipment, such as protective clothing and gear, heavy equipment, empty drums, overpack drums, hand tools, and absorbent materials
- Transfer the released material to a container that is in good condition and patch or overpack the leaking container into another container that is in good condition
- Once the release has been contained, determine the areal extent of the release and proceed with appropriate cleanup action, such as chemical neutralization, vacuuming, or excavation

D-4c Assessment of the Potential Hazards

Concurrent with the actions described in Sections D-4a and D-4b, and in accordance with 20.4.1.300 NMAC (incorporating 40 CFR §262.265(c)) and 20.4.1.500 NMAC (incorporating 40 CFR §264.56(c)), the RCRA Emergency Coordinator shall assess possible hazards to human health or the environment that may result from the release, fire, or explosion. This assessment will consider both direct and indirect effects of the release, fire, or explosion (e.g., the effects of any toxic, irritating, or asphyxiating gases that are generated, or the effects of any hazardous surface water run-off from water or chemical agents used to control fire and heat-induced explosions). The RCRA Emergency Coordinator will be responsible for identifying and responding to immediate and potential hazards, using the services of trained personnel.

After the materials involved in an emergency are identified, the specific information (e.g., associated hazards, appropriate personal protective equipment (PPE), decontamination) may be obtained from SDSs and from appropriate chemical reference materials at the same location. These information sources are available to the RCRA Emergency Coordinator or may be accessed through several WIPP facility organizations.

If, upon completion of the hazards assessment, the RCRA Emergency Coordinator determines that there are no actual or potential hazards to human health or the environment present, this *RCRA Contingency Plan* may be terminated. The RCRA Emergency Coordinator will record the time, date, and details of the incident in the Operating Record, and the Permittees will ensure that the reporting requirements of Section D-5 are fulfilled.

D-4d Post-Assessment Notifications

Upon *RCRA Contingency Plan* implementation, post-assessment notifications may be necessary in order to satisfy 20.4.1.300 NMAC (incorporating 40 CFR §262.265(d)) and 20.4.1.500 NMAC (incorporating 40 CFR §264.56(d)). If it has been determined that the facility has had a fire, an explosion, or a release of hazardous waste or hazardous waste constituents that could threaten human health or the environment outside the facility (i.e., outside the Land Withdrawal Boundary), the RCRA Emergency Coordinator, after consultation with the DOE as the owner of the facility, will ensure that the appropriate local authorities are immediately notified by telephone and/or radio in the event that evacuation is needed. The following notifications satisfy the requirements of 20.4.1.300 NMAC (incorporating 40 CFR §262.265(d)(1)) and 20.4.1.500 NMAC (incorporating 40 CFR §264.56(d)(1)):

- New Mexico Department of Homeland Security and Emergency Management
(telephone number: (505) 476-9635)
- Eddy County via the Regional Emergency Dispatch Authority
(telephone number: (575) 616-7155)
- Lea County via the Regional Emergency Dispatch Authority
(telephone number: (575) 397-9265)

The RCRA Emergency Coordinator must be available to help appropriate officials decide whether local areas should be evacuated.

After local authorities are notified, the RCRA Emergency Coordinator must immediately notify either the government official designated as the on-scene coordinator for that geographical area, or the National Response Center. For the purposes of the *RCRA Contingency Plan*, the following notifications satisfy the requirements of 20.4.1.300 NMAC (incorporating 40 CFR §262.265(d)(2)) and 20.4.1.500 NMAC (incorporating 40 CFR §264.56(d)(2)):

- New Mexico Environment Department (NMED)
Department of Public Safety
24-Hour Emergency Reporting Telephone Number: (505) 827-9329
FAX number: (505) 827-9368
- National Response Center
Telephone number: 1-800-424-8802
FAX number: (202) 479-7181

This notification shall include the following information:

- The name and phone number of the reporter
- The name and address of the facility
- The type of incident (fire, explosion, or release)
- The date and time of the incident
- The name and quantity of material(s) involved, to the extent known
- The extent of injuries, if any
- Possible hazards to human health and the environment (air, soil, water, wildlife, etc.) outside the facility

Communications beyond those required by the *RCRA Contingency Plan* are the responsibility of the Permittees in accordance with plans and policies on file at the WIPP facility.

D-4e Control and Containment of the Emergency

The RCRA Emergency Coordinator is required to ensure control of an emergency and to minimize the potential for the occurrence, recurrence, or spread of releases due to the emergency situation, as described in 20.4.1.300 NMAC (incorporating 40 CFR §262.265(e) and (f)) and 20.4.1.500 NMAC (incorporating 40 CFR §264.56(e) and (f)). Standard operating procedures and guides are used to implement initial response measures with priority being control of the emergency, and those actions necessary to ensure confinement and containment in the early, critical stages of a spill or leak. The RCRA Emergency Coordinator, in conjunction with the Incident Commander, is responsible for implementing the following measures:

- Stopping processes and operations
- Collecting and containing released wastes and materials
- Removing or isolating containers of hazardous waste posing a threat
- Ensuring that wastes managed during an emergency are handled, stored, or treated with due consideration for compatibility with other wastes and materials on site and with containers utilized (Section D-4f(2))
- Restricting personnel not needed for response activities from the scene of the incident
- Evacuating the area
- Curtailing nonessential activities in the area
- Conducting preliminary inspections of adjacent facilities and equipment to assess damage
- Maintaining fire equipment on standby at the incident site in cases where ignitable liquids have been or may be released and ensuring that ignition sources are kept out of the area. Ignitable liquids will be segregated, contained, confined, diluted, or otherwise controlled to preclude inadvertent explosion or detonation.

No operation that has been shut down in response to the incident will be restarted until authorized by the RCRA Emergency Coordinator. If a release occurs that involves radioactivity, the RCRA Emergency Coordinator actions will be consistent with radiation control policies and practices.

The standard operating procedures for emergency response may include, but are not limited to, the following actions appropriate for control of releases:

1. Isolating the area from unauthorized entry by fences, barricades, warning signs, or other security and site control precautions. Isolation and evacuation distances vary, depending upon the chemical/product, fire, and weather situations.
2. Establishing drainage controls.
3. Stabilizing physical controls (such as dikes or impoundment[s]).

4. Capping contaminated soils to reduce migration.
5. Using chemicals and other materials to retard the spread of the release or to mitigate its effects.
6. Excavating, consolidating, or removing contaminated soils.
7. Removing wastes containers to reduce exposure risk during situations such as fires.

If the facility stops operations in response to a fire, explosion, or release, the RCRA Emergency Coordinator shall ensure continued monitoring for leaks, pressure buildup, gas generation, or ruptures in valves, pipes, or other equipment, wherever appropriate.

Natural and/or synthetic methods will be employed to limit the releases of hazardous wastes or hazardous waste constituents so that effective recovery and treatment can be accomplished with minimal additional risk to human health or the environment.

Emergency response actions taken to mitigate releases may include, but are not limited to, the following:

1. Physical methods of control may involve any of several processes to reduce the area of the spill/leak, or other release mechanism (such as fire suppression).
 - a. Absorption (e.g., absorbent sheets; spill control bucket materials specifically for solvents, neutralization, or acids/caustics; and absorbent socks for general liquids or oils)
 - b. Dikes or Diversions (e.g., absorbent socks or earth)
 - c. Overpacking
 - d. Plug and Patch
 - e. Transfers from leaking container to new container
 - f. Vapor Suppression (e.g., aqueous foam blanket)
2. Chemical methods of mitigation may include the following:
 - a. Neutralization
 - b. Solidification

Once the Incident Commander informs the RCRA Emergency Coordinator that the emergency scene is stable, the release has been stopped, any reactions have been controlled, the released hazardous materials have been contained within a localized area, and the area of contamination has been secured from unauthorized entry, the field emergency response activity can be terminated.

D-4e(1) Fires

In the event of a fire that involves or threatens TRU mixed waste or site-generated hazardous waste, emergency response actions may include, but are not limited to, the following:

1. The RCRA Emergency Coordinator will remain in contact with and advise the Incident Commander of the known hazards.
2. The Incident Commander will maintain overall control of the emergency and may accept and evaluate the advice of WIPP facility personnel and emergency response organization members but retains overall responsibility until the emergency is terminated.
3. Only fire extinguishing materials that are compatible with the materials involved in the fire will be used to extinguish fires. Water and dry chemical materials in use at the WIPP facility have been determined to be compatible with components of the TRU mixed waste and site-generated hazardous waste.
4. In order to ensure that storm drains and/or sewers do not receive potentially hazardous runoff, dikes will be built around storm drains to control discharge as needed. Collected waste will be sampled and analyzed for hazardous constituents, and appropriately disposed.
5. The RCRA Emergency Coordinator will ensure that measures are taken to shut down operational units (e.g., process equipment and ventilation equipment) that have been affected directly or indirectly by the fire.
6. Fire suppression materials used in response to incidents will be retained on-scene, where an evaluation will be performed to determine appropriate recovery and disposal methods.
7. Upon underground evacuation due to a fire in the underground that involves or threatens to involve TRU mixed waste or site-generated hazardous waste, a response plan will be developed depending on the status of the fire. The plan may include ventilation control, barrier erection, and/or waiting for the fire to self-extinguish or implement active ventilation.

D-4e(2) Explosions

In the event of an explosion that involves or threatens TRU mixed waste or site-generated hazardous waste, emergency response actions may include, but are not limited to, the following:

1. The RCRA Emergency Coordinator will remain in contact with and advise the Incident Commander of the known hazards.
2. The Incident Commander will maintain overall control of the emergency and may accept and evaluate the advice of WIPP facility personnel and emergency response organization members but retains overall responsibility until the emergency is terminated.

3. The RCRA Emergency Coordinator will ensure measures are taken to shut down operational units (e.g., process equipment and ventilation equipment) that have been affected directly or indirectly by the explosion.
4. If, following an explosion, there is an ensuing fire, see Section D-4e(1).
5. If, following an explosion, there is an underground structural integrity emergency, see Section D-4e(4).

D-4e(3) Unplanned Sudden/Non-Sudden Releases

Spills of Site-Generated Hazardous Waste

If a spill of site-generated hazardous waste has occurred, and 1) the spill cannot be contained with secondary containment methods or absorbents, 2) the spill causes a release of flammable material, or 3) the spill results in toxic fumes, the RCRA Emergency Coordinator will ensure implementation of measures that may include, but are not limited to, the following actions:

1. The RCRA Emergency Coordinator will remain in contact with and advise the Incident Commander of the known hazards.
2. The Incident Commander will maintain overall control of the emergency and may accept and evaluate the advice of WIPP facility personnel and emergency response organization members but retains overall responsibility until the emergency is terminated.
3. The immediate area will be evacuated.
4. The source of the release will be mitigated, if possible.
5. A dike to contain runoff will be built, if necessary.
6. Dikes around storm drains to control discharge will be built, as needed, to ensure that storm drains and/or sewers do not receive potentially hazardous runoff.
7. Fire equipment will be maintained on standby at the incident site in cases where ignitable liquids have been or may be released, and ignition sources will be kept out of the area of ignitable liquids.
8. Released waste and contaminated media will be collected and placed into drums or other appropriate containers.

Releases of TRU Mixed Waste

If a release of TRU mixed waste has occurred, the emergency will be managed as a potential radiological release, and radiological control measures will determine the activities that can be performed safely, which may include the following:

1. The RCRA Emergency Coordinator will remain in contact with and advise the Incident Commander of the known hazards.
2. The Incident Commander will maintain overall control of the emergency and may accept and evaluate the advice of WIPP facility personnel and emergency response organization members but retains overall responsibility until the emergency is terminated.
3. Prior to the re-entry following an event involving containers that are managed as TRU mixed waste, a Radiological Work Permit (RWP) will be prepared.
4. During the re-entry phase, the extent of radiological contamination will be determined. This information is used by the RCRA Emergency Coordinator to determine an appropriate course of action to recover the area.
5. During the recovery phase, the resources to conduct decontamination and/or overpacking operations will be used as needed.
6. Prior to returning the affected area and/or equipment to normal activities, the RCRA Emergency Coordinator will determine if additional measures are required by the *RCRA Contingency Plan* (e.g., characterization and disposal of contaminated media).
7. The recovery phase will include activities (e.g., placing the waste material in another container, vacuuming the waste material, overpacking or plugging/patching the affected waste container(s), decontaminating or covering the affected area), as specified in the RWP, to minimize the spread of contamination to other areas.
8. The RWPs and other administrative controls will provide protective measures to help ensure that new hazardous constituents will not be added during decontamination activities.

D-4e(4) Other Occurrences

Natural Phenomena

In the event of a natural phenomenon (e.g., earthquake, flood, lightning strike, tornado) that involves hazardous waste or has threatened to cause a release of hazardous waste or hazardous waste constituents, emergency response actions may include, but are not limited to, the following:

1. The RCRA Emergency Coordinator will remain in contact with and advise the Incident Commander of the known hazards.
2. The Incident Commander will maintain overall control of the emergency and may accept and evaluate the advice of WIPP facility personnel and emergency response organization members but retains overall responsibility until the emergency is terminated.
3. Containers that have not been disposed will be inspected for signs of leakage or damage, and containment systems will be inspected for deterioration.

4. Affected equipment or areas associated with hazardous waste management activities will be inspected, and the operability of monitoring systems will be ensured.
5. Affected electrical equipment and lines will be inspected for damage.
6. Affected buildings and fencing directly related to hazardous waste management activities will be inspected for damage.
7. A general survey of the site will be conducted to check for signs of physical damage.
8. The RCRA Emergency Coordinator will ensure that measures are taken to shut down operational units (e.g., process equipment and ventilation equipment) that have been affected by the natural phenomenon.

Underground Structural Integrity Emergencies

In the event of an underground structural integrity emergency that involves or threatens TRU mixed waste (i.e., occurs in an active disposal room) or site-generated hazardous waste, the emergency will be managed as a potential radiological release, and radiological control measures will determine the activities that can be performed safely, and may include the following:

1. The RCRA Emergency Coordinator will remain in contact with and advise the Incident Commander of the known hazards.
2. The Incident Commander will maintain overall control of the emergency and may accept and evaluate the advice of WIPP facility personnel and emergency response organization members but retains overall responsibility until the emergency is terminated.
3. The RCRA Emergency Coordinator will ascertain whether the roof conditions allow for safe entry and if the waste container or containers in question are accessible.
4. The RCRA Emergency Coordinator may recommend closing the entire panel, or the affected room of waste containers, based on the location of the event and the stability of the roof and walls in the panel as a method to ensure that measures are taken to shut down affected operational units.
5. Access to the ventilation flow path downstream of the incident will be restricted, as appropriate.
6. Ventilation to the affected room will be restricted to ensure that there is no spread of contamination that may have been released, as appropriate.
7. Accessible containers will be inspected for signs of leakage or damage.

8. The spill area will be covered with material (e.g., plastic, fabric sheets) in a manner that safely isolates the contamination in the area.
9. The RCRA Emergency Coordinator will determine if the covered spill area safely allows for continued waste disposal operations or whether further action is required to reinstate operations.

D-4f Post-Emergency Activities

Immediately after the emergency, and once initial release or spill control and containment have been completed, the RCRA Emergency Coordinator will ensure that necessary decontamination occurs and that recovered hazardous waste is properly managed, stored, and/or disposed, as required by 20.4.1.300 NMAC (incorporating 40 CFR §262.265(g)) and 20.4.1.500 NMAC (incorporating 40 CFR §264.56(g)). As required by 20.4.1.300 NMAC (incorporating 40 CFR §262.265(h)) and 20.4.1.500 NMAC (incorporating 40 CFR §264.56(h)), the RCRA Emergency Coordinator will ensure that incompatibility of waste and restoration of emergency equipment are addressed.

D-4f(1) Management and Disposition of Released Material

When a release of TRU mixed waste has occurred, priority is given to actions required to minimize radiological exposure to workers and the public. If the release is TRU mixed waste, decontamination and disposition will be in accordance with the RWP. If a release of site-generated hazardous waste occurs, the contaminated surface will be cleaned, and decontamination materials will be placed in containers and dispositioned appropriately. In most cases, actions taken to address a radiological contamination are sufficient to mitigate any health effects associated with contamination by hazardous waste or hazardous waste constituents.

If radioactive contamination is detected on equipment or on structures, radiological cleanup standards will be used to determine the effectiveness of decontamination efforts and/or the final disposition of the equipment or structures. Many types of equipment are difficult to decontaminate and may have to be discarded as derived waste. Fixatives (e.g., paint or water spray on salt in the underground) may be used on contaminated structures if the contamination cannot be safely removed.

Following decontamination, the RCRA Emergency Coordinator will ensure that nonradioactive hazardous waste resulting from the cleanup of a fire, an explosion, or a release involving a nonradioactive hazardous waste at the WIPP facility will be contained and managed as a hazardous waste until such time as the waste is disposed of, or determined to be nonhazardous, as defined in 20.4.1.200 NMAC (incorporating 40 CFR Part 261, Subparts C and D). In most cases, knowledge of the material inventories for the various buildings and areas at the facility will allow a hazardous waste determination for the material resulting from the cleanup of a release. When knowledge of the material inventories is not sufficient, samples of the waste will be collected and analyzed using U.S. Environmental Protection Agency (EPA)-approved methods to determine the presence of any hazardous characteristics and/or hazardous waste constituents.

D-4f(2) Incompatible Waste

The RCRA Emergency Coordinator will ensure, in accordance with 20.4.1.300 NMAC (incorporating 40 CFR §262.262(h)(1)) and 20.4.1.500 NMAC (incorporating 40 CFR §264.56(h)(1)), that in the affected area(s) of the facility, no waste that may be incompatible with the released material is treated, stored, or disposed of until cleanup has been completed. The RCRA Emergency Coordinator will not allow hazardous or TRU mixed waste operations to resume in a building or area in which incompatible materials have been released prior to completion of necessary post-emergency cleanup operations to remove potentially incompatible materials. In making the determination of compatibility, the RCRA Emergency Coordinator will have available the resources and information described in Section D-4b, *Identification of Released Materials and Assessment of the Extent of the Emergency*.

D-4f(3) Cleaning and Restoration of Equipment

The RCRA Emergency Coordinator will take measures to ensure, in accordance with 20.4.1.300 NMAC (incorporating 40 CFR §262.262(h)(2)) and 20.4.1.500 NMAC (incorporating 40 CFR §264.56(h)(2)), that in the affected area(s) of the facility, emergency equipment listed in the *RCRA Contingency Plan*, and used in the emergency response, is cleaned and fit for its intended use or replaced before operations are resumed.

Any equipment that cannot be decontaminated will be discarded as waste (e.g., hazardous, mixed, solid), as appropriate. After the equipment has been cleaned, repaired, or replaced, a post-emergency facility and equipment inspection will be performed, and the results will be documented.

D-5 Required Reporting

The RCRA Emergency Coordinator, on behalf of the Permittees, will note in the Operating Record the time, date, and details of the incident that required implementation of the *RCRA Contingency Plan*. In compliance with 20.4.1.300 NMAC (incorporating 40 CFR §262.265(i)) and 20.4.1.500 NMAC (incorporating 40 CFR §264.56(i)), within 15 days after the incident, the Permittees will ensure that a written report on the incident will be submitted to the Secretary of the NMED. The report will include:

- The name, address, and telephone number of the Owner/Operator
- The name, address, and telephone number of the facility
- The date, time, and type of incident (e.g., fire, explosion, or release)
- The name and quantity of material(s) involved
- The extent of injuries, if any
- An assessment of actual or potential hazards to human health or the environment, where this is applicable
- The estimated quantity and disposition of recovered material that resulted from the incident

D-6 Emergency Equipment

A variety of equipment is available at the facility for emergency response, containment, and cleanup operations in the surface HWMUs, the underground HWDUs, and the WIPP facility in general. This includes equipment for spill control, fire control, personnel protection, monitoring, first aid and medical attention, communications, and alarms. This equipment is immediately available to emergency response personnel. A listing of major emergency equipment available at the WIPP facility, as required by 20.4.1.300 NMAC (incorporating 40 CFR §262.261(e)) and 20.4.1.500 NMAC (incorporating 40 CFR §264.52(e)), is shown in Table D-2. Table D-2 also includes the location and a physical description of each item on the list along with a brief outline of its capabilities. The fire-water distribution system map is shown in Figure D-4/Figure D-4-NFB. Equipment specified at the locations listed in Table D-2 are inspected in accordance with the inspection schedule specified in Attachment E, Table E-1, as required by 20.4.1.500 NMAC (incorporating 40 CFR §264.15(b)).

D-7 Emergency Response Agreements

The Permittees have established agreements with federal, state, and local emergency response agencies and mining companies in the vicinity of the WIPP facility for firefighting, medical assistance, hazardous materials response, and law enforcement. In the event that on-site response resources are unable to provide the needed response actions during a medical, fire, hazardous materials, or security emergency, the RCRA Emergency Coordinator will notify appropriate emergency response agencies and request assistance. Once on site, emergency response agency personnel will perform emergency response activities under the direction of the Incident Commander.

The agreements with federal, state, and local agencies and mining companies in the vicinity of the WIPP facility for emergency response capabilities are on file at the WIPP facility. Additional agreements may be established when needed. Descriptions of the agreements with federal, state, and local agencies and mining operations in the vicinity of the WIPP facility, as required by 20.4.1.300 NMAC (incorporating 40 CFR §§262.256 and 262.261(c)) and 20.4.1.500 NMAC (incorporating 40 CFR §264.37 and §264.52(c)), include, but is not limited to, the following:

- Agreements with local mining companies, including Intrepid Potash NM LLC, White Marble Mine, and Mosaic Potash Carlsbad Inc. provide for mutual aid and assistance, in the form of MRTs, in the event of a mine disaster or other circumstance at either of the facilities. This provision ensures that the WIPP MOC will have two MRTs available at all times when miners are underground.
- An agreement with the U.S. Department of Interior (DOI), represented by the Bureau of Land Management (BLM), Roswell District, for wildland firefighting support within the WIPP Land Withdrawal Area.
- Agreements for mutual-aid firefighting with Eddy County, the City of Hobbs, and the City of Carlsbad for assistance, including equipment and personnel.
- Mutual-aid Agreements with the City of Hobbs and the City of Carlsbad for mutual ambulance, medical, rescue, and hazardous material response services; for use of WIPP facility radio frequencies during emergencies; and for mutual security and law enforcement services, within the appropriate jurisdiction limits of each party.

- Agreements with the Covenant Health Hobbs Hospital and the Carlsbad Medical Center for the treatment of persons with radiological contamination who have incurred injuries beyond the treatment capabilities at the WIPP facility. The WIPP facility provides transport of the patient(s) to these facilities.
- Agreements with the Sheriff of Eddy County and the Sheriff of Lea County for mutual law enforcement services support.
- An agreement with the New Mexico Department of Homeland Security and Emergency Management for mutual emergency management support, access to state law enforcement, public works, and transportation assets.

D-8 Evacuation Plan

If it becomes necessary to evacuate all or part of the WIPP facility, on-site assembly and off-site staging areas have been established. The off-site staging areas are outside the security fence. The Permittees have plans and implementation procedures for both surface and underground evacuations. Drills are performed on these procedures at the WIPP facility at least annually. The following sections describe the evacuation plan for the WIPP facility, as required under 20.4.1.300 NMAC (incorporating 40 CFR §262.261(f)) and 20.4.1.500 NMAC (incorporating 40 CFR §264.52(f)).

D-8a Surface Evacuation On-site Assembly and Off-site Staging Areas

Figures D-1/Figure D-1-NFB show the surface assembly and staging areas and the evacuation gates. Security officers remain at the WIPP facility main gate 24 hours a day, and the vehicle trap is opened for personnel during emergency evacuations. The north gate has a single-person gate and a large gate that can be opened, similar to the main gate, for the primary staging area. Alternative evacuation route exit points are located at the east and south gates. The east and south gates are turnstile gates. Upon notification, security personnel will respond, open gates, and facilitate egress for evacuation.

If a building or area evacuation is necessary, the RCRA Emergency Coordinator, in conjunction with the Incident Commander, will determine which assembly area is to be used and will communicate the selection to facility personnel. The preferred evacuation route is determined based on the nature of the event, prevailing weather conditions, and actual or potential radiological release. If site evacuation is necessary, the RCRA Emergency Coordinator, in conjunction with the Incident Commander, will decide which staging area is to be used and will communicate the selection to facility personnel. The WIPP site evacuation routes are shown in Figure D-8. The surface evacuation alarm and public address system are used to direct personnel evacuation. Persons responsible for surface accountability will direct personnel to the selected staging area outside the security fence.

Personnel report to the designated assembly or staging area where accountability is conducted (Figure D-1/Figure D-1-NFB). Personnel who are working in a contaminated area when site evacuation is announced will assemble at specific staging areas for potentially contaminated personnel in order to minimize contact with other personnel during the evacuation.

D-8b Underground Assembly Areas and Egress Hoist Stations

Depending upon the type of emergency and level of response, it may be necessary for personnel in the underground to shelter in place, report to designated assembly areas (Figure D-3), or to evacuate the underground. Underground personnel are trained to immediately report to assembly areas under specific circumstances (i.e., loss of underground power or ventilation). Underground accountability is taken when the underground is sheltered in place or evacuated. The Underground Controller is responsible for underground personnel accountability. Each assembly area contains a mine pager phone, miner's aid station, and evacuation maps.

In accordance with 30 CFR §57.11050, the mine maintains two escapeways. These escapeways are designated as Egress Hoist Stations. When the need for an underground evacuation has been determined, underground personnel report to the Egress Hoist Stations.

Decontamination of underground personnel will be conducted consistent with radiological control procedures pursuant to 10 CFR Part 835. Contaminated personnel are trained to remain segregated from other personnel until radiological contamination control personnel can respond.

D-8c Plan for Surface Evacuation

Surface evacuation notification is initiated by the CMRO, as directed by the RCRA Emergency Coordinator, via sounding of the surface evacuation alarm and providing incident information via the public address system. The persons responsible for surface accountability assist personnel in evacuation from their areas. Egress routes from buildings and site evacuation routes and instructions are posted in designated areas throughout the site. Egress routes from the WHB Unit are shown in Figures D-5 through D-7.

D-8d Plan for Underground Evacuation

Notification for underground evacuation will be made using the underground evacuation alarm and strobe light signals.

Personnel will evacuate to the nearest Egress Hoist Station. Primary underground escape routes (identified by green reflectors on the rib) will be used, if possible. Secondary underground escape routes (identified by red reflectors on the rib) will be used if necessary (Figure D-3). Detailed descriptions of escapeways and an underground escape map are included in the *Underground Escape and Evacuation Plan* on file at the WIPP facility, as required by MSHA, 30 CFR §57.11053, for underground mining situations. The MSHA required map takes precedence over Figure D-3, *Underground Escape and Evacuation Map*, should an underground mine related event occur necessitating a change to the evacuation routes. The Underground Controller is responsible for underground personnel accountability and for reporting accountability to the RCRA Emergency Coordinator.

Upon reaching the surface, personnel will report to their on-site surface assembly or off-site staging area, as directed, to receive further instructions.

Members of the WIPP Fire Department and the MRT who may be underground, will assist in the evacuation of the underground when an underground evacuation is called for. A reentry by the MRT will be performed according to 30 CFR Part 49 and MSHA regulations for reentry into a

mine. The MRTs are trained in compliance with 30 CFR Part 49 in mine mapping, mine gases, ventilation, exploration, mine fires, rescue, and recovery.

D-8e Further Site Evacuation

In the event of an evacuation involving the need to transport employees, the following transportation will be available:

- Buses/vans—WIPP facility buses/vans will be available for evacuation of personnel. The buses/vans are stationed in the employee parking lot.
- Privately Owned Vehicles—Because many employees drive to work in their own vehicles, these vehicles may be used in an emergency. Personnel will be provided routes to be taken when leaving the facility.

These vehicles may be used to transport personnel who have been released from the site by the RCRA Emergency Coordinator.

The primary evacuation route for the WIPP facility is Louis Whitlock Road, which connects to U.S. Highway 62/180 to the north and State Highway 128 via the South Access Road. Alternate evacuation routes from the facility are provided at the south side and the east side of the facility. Utilization of the alternate evacuation routes leads to either the main DOE north/south access road or Campbell Road, which travels north and intersects with U.S. Highway 62/180. The primary and alternate evacuation routes are depicted in Figures D-8 and D-8a.

D-9 Location of the RCRA Contingency Plan and Plan Revision

In accordance with 20.4.1.300 NMAC (incorporating 40 CFR §§262 and 262.262(a)) and 20.4.1.500 NMAC (incorporating 40 CFR §264.53(a)), the owner/operator of the WIPP facility will ensure that copies of this *RCRA Contingency Plan* are maintained at the WIPP facility and are available to the emergency personnel and organizations described in Section D-2. When the *RCRA Contingency Plan* is revised, updated copies are distributed (electronically or via site mail) or hand delivered to applicable WIPP facility emergency personnel and Emergency Operations Centers. In addition, the Permittees will make copies available to the following federal, state, and local agencies and mining companies in the vicinity of the WIPP facility, as required by 20.4.1.300 (incorporating 40 CFR §262.262(a)) and 20.4.1.500 NMAC (incorporating 40 CFR §264.53(b)):

- Intrepid Potash New Mexico LLC
- White Marble Mine
- Mosaic Potash Carlsbad Inc.
- City of Carlsbad
- Carlsbad Medical Center, Carlsbad
- Covenant Health Hobbs Hospital, Hobbs
- City of Hobbs
- BLM, Carlsbad
- New Mexico State Police
- New Mexico Department of Homeland Security and Emergency Management
- Eddy County Commission

Waste Isolation Pilot Plant
Hazardous Waste Facility Permit
Attachment D
October 2023

- Sheriff of Eddy County
- Sheriff of Lea County
- Eddy County Fire and Rescue
- Eddy County Emergency Management
- Lea County Emergency Management

In accordance with 20.4.1.300 NMAC (incorporating 40 CFR §262.263) and 20.4.1.500 NMAC (incorporating 40 CFR §264.54), the Permittees will ensure that this plan is reviewed and amended whenever:

- The Permit for the WIPP facility is revised in any way that would affect the *RCRA Contingency Plan*;
- This plan fails in an emergency;
- The WIPP facility design, construction, operation, maintenance, or other circumstances change in a way that materially increases the potential for fires, explosions, or releases of hazardous waste or hazardous constituents or change the response necessary in an emergency;
- The list of RCRA Emergency Coordinators changes; or
- The list of WIPP facility emergency equipment changes.

Waste Isolation Pilot Plant
Hazardous Waste Facility Permit
Attachment D
October 2023

TABLES

**Table D-1
 Resource Conservation and Recovery Act Emergency Coordinators¹**

Name	Address*	Office Phone	Personal Phone*	24-Hour Emergency Phone
J.E. (Joseph) Bealler		(575) 234-8276 or (575) 234-8916		(575) 234-8111
M.G. (Mike) Proctor		(575) 234-8276 or (575) 234-8143		(575) 234-8111
P.J. (Paul) Paneral		(575) 234-8498		(575) 234-8111
A.C. (Andy) Cooper		(575) 234-8197		(575) 234-8111
C.J. (Chris) Belis		(575) 628-5851		(575) 234-8111
B.R. (Bobby) Franco		(575) 234-8163		(575) 234-8111
G.W. (Gregory) Brown		(575) 234-5862		(575) 234-8111
R.E. (Eric) Chavez		(575) 234-5831		(575) 234-8111
D.L. (Donald) Journey		(575) 234-8216		(575) 234-8111
R.H. (Robert) Valenzuela		(575) 234-8799		(575) 234-8111
J.R. (James) Bailey		(575) 234-8276		(575) 234-8111
M.L. (Martin) Mendes		(575) 234-5822		(575) 234-8111
D.J. (Derek) Tweedy		(575) 234-8272		(575) 234-8111
J.W. (Justin) Bailey		(575) 234-8276		(575) 234-8111

* NOTE: Personal information (home addresses and personal phone numbers) has been removed from informational copies of this Permit.

¹ For every shift, one qualified RCRA Emergency Coordinator serves as the primary, and a second qualified RCRA Emergency Coordinator is available to serve as the alternate.

**Table D-2
Emergency Equipment Maintained at the Waste Isolation Pilot Plant**

Equipment	Description and Capabilities	Location
Communications		
Building Fire Alarms	Fire alarm panels, fire alarm transmitter, audible alarm devices (e.g., horns, bells, tones) that provide notification of fires; transmitted to the CMR	Guard and Security Building (Building 458), Water Pumphouse (Building 456), Warehouse/Shops Building (Building 453), Exhaust Shaft Filter Building (Building 413), New Filter Building (NFB) (Building 416), Salt Reduction Building (SRB) (Building 417), Support Building (Building 451), CMR/Computer Room, Waste Handling Building (Building 411), TRUPACT Maintenance Building (Building 412), Salt Handling (SH) Shaft Hoisthouse (Building 384), Auxiliary Warehouse Building (Building 455), Engineering Building (Building 486), Training Building (Building 489), Safety and Emergency Services Facility (Building 452), and CAAs (Buildings 474A and 474B)
Underground Fire Alarms	Fire alarm panels, fire alarm transmitter, and audible/visual alarm devices (e.g., horns, bells, strobes) that provide notification of fires; transmitted to the CMR	Fire detection and control panel locations: Waste Shaft Underground Station, SH Shaft Underground Station, Between E-140 and E-300 in S-2180 Drift, Fuel Station (N150/W170)
Site Notification System; Underground Evacuation Alarm System	For surface, alarms and notifications transmitted over paging channel of the public address system, manually initiated; for underground, audible alarm	Site-wide
Public Address System	Includes intercom phones; handset stations and loudspeaker assemblies	Site-wide

Waste Isolation Pilot Plant
Hazardous Waste Facility Permit
Attachment D
October 2023

Equipment	Description and Capabilities	Location
Mine Pager Phones	Battery-operated paging system	Underground at E300 Maintenance Shop, S550/W30, S700/W30, S1600/E140, SH Shaft Collar and Underground Station Waste Shaft Collar and Underground Station; – surface at Support Building (Building 451, FSM desk, CMR, lamproom), Safety and Emergency Services Facility (Building 452, Fire Department workstation area, Mine Rescue Room)
Portable Radios	Two-way, portable; transmits and monitors information to/from other transmitters	Issued to individuals
Plant-Based Radios	Two-way, stationary; transmits and monitors information to/from other radios	Safety and Emergency Services Facility (Building 452), Guard and Security Building (Building 458), Support Building (Building 451, CMR, FSM desk)
Mobile Phones	Provide communications link between emergency response personnel, as needed	Issued to individuals plus emergency vehicles
Spill Response Equipment and Materials		
HAZMAT Equipment	Spill response equipment and supplies, PPE, and decontamination supplies stored and maintained in accordance with NFPA 1901 and as documented in WIPP facility files	Surface, in designated areas near Safety and Emergency Services Facility (Building 452)
Absorbent Materials	Containment or cleanup of spills, including: Pressurized spill-response gun; Absorbent sheets and/or dikes for containment or cleanup of spills of oil, petroleum-based chemicals, and general liquids; Spill-control material for solvents and neutralizing absorbents and for acids/caustics	Surface, in designated areas near Safety and Emergency Services Facility (Building 452)
Medical Resources		
Ambulance	A minimum of one ambulance, maintained and equipped in accordance with the New Mexico Ambulance Standard, 18.3.14 NMAC, and as documented in WIPP facility files	Surface at Safety and Emergency Services Facility (Building 452, Vehicle Bay)
Medical Cart	A minimum of one medical cart, equipped to provide basic life support operations, as documented in WIPP facility files	Underground (Emergency Vehicle Parking/Charging Area at S700/E140)
Miners First Aid Stations	Equipped per 30 CFR 57.15001	Underground (Salt Shaft Area, Waste Shaft Area, E300 Maintenance Shop, and at S700/W30, S1300/W30, and S1600/E140)

Equipment	Description and Capabilities	Location
Fire Detection and Fire Suppression Equipment		
Building Smoke, Thermal Detectors, or Manual Pull Stations	Devices that trigger an alarm and/or fire suppression system	Guard and Security Building (Building 458), Warehouse/Shops Building (Building 453), Support Building (Building 451, CMR/Computer Room), Waste Handling Building (Building 411), TRUPACT Maintenance Building (Building 412), Underground Fuel Station (N150/W170), SH Shaft Hoisthouse (Building 384), Engineering Building (Building 486), Safety and Emergency Services Facility (Building 452), and Training Building (Building 489)
Fire Trucks	A minimum of two fire trucks with rescue equipment to assist in fighting fires and emergency rescue; firefighter equipped in accordance with NFPA 1901 and/or 1906 and as documented in WIPP facility files	Surface at Safety and Emergency Services Facility (Building 452, Vehicle Bay)
Rescue Cart	A minimum of one light rescue unit, equipped in accordance with the NFPA 1901 and as documented in WIPP facility files	Underground (Emergency Vehicle Parking/Charging Area at S700/E140)
Fire Suppression Cart	A minimum of one special-purpose electric cart to assist in fighting fires; equipped with a minimum of one fire extinguisher	Underground (Emergency Vehicle Parking/Charging Area at S700/E140)
Fire Extinguishers	Hand-held fire extinguishers; located throughout the facility in accordance with NFPA 10	Surface and underground locations used for hazardous waste management, as documented in WIPP facility files
Automatic Dry Chemical Extinguishing Systems	Automatic; actuated by thermal detectors or by manual pull stations	Underground fuel station (N150/W170)
Automatic Fire Suppression Systems on liquid fueled vehicles	Individual automatic fire suppression systems installed on applicable liquid-fueled vehicles, as determined by a fire risk assessment performed in accordance with NFPA 122	Surface and underground locations used for hazardous waste management, as documented in WIPP facility files

Waste Isolation Pilot Plant
Hazardous Waste Facility Permit
Attachment D
October 2023

Equipment	Description and Capabilities	Location
Sprinkler Systems	NFPA water-based fire suppression systems	Water Pumphouse (Building 456), Guard and Security Building (Building 458), Waste Handling Building (Building 411, CH Bay, RH Bay, and Overpack Repair Areas only), TRUPACT Maintenance Building (Building 412), Exhaust Shaft Filter Building (Building 413), NFB (Building 416), SRB (Building 417), and CAAs (Buildings 474A and 474B)
Water Tanks, Hydrants	Fire suppression water supply; one 180,000-gallon capacity tank, plus a second tank with 100,000-gallon reserve	Tanks are at southwestern edge of WIPP facility; pipelines and hydrants are throughout the surface
Fire Water Pumps	Fire suppression water supply; pumps are minimally rated at 125 pounds per square inch, 1,500 gallons per minute centrifugal pump, one with electric motor drive, the other with diesel engine; pressure maintenance jockey pump	Water Pumphouse (Building 456)
Personal Protection Equipment		
Head Lamps	Mounted on hard hat; battery operated	Each person underground
Underground Self-Rescuer Units	Short-term self-rescue devices per 30 CFR 57.15030	Each person underground
Self-Contained Self-Rescuer	Air supply; a minimum of 12 caches in the underground; self-contained rescue units shall be adequate to protect an individual for one hour or longer or, alternatively, sufficient to allow the employee time to reach an additional self-contained self-rescue device in the underground per NMSA 69-8-16	Cached throughout the underground
Mine Rescue Self-Contained Breathing Apparatus (SCBA)	Oxygen supply; 4-hour closed circuit units consistent with 30 CFR 49.6; a minimum of 12 units, one for each Mine Rescue Team member	Safety and Emergency Services Facility (Building 452, Mine Rescue Training Room)
Fire Department Self-Contained Breathing Apparatus (SCBA)	Air supply; a minimum of 12 units; SCBAs shall meet the minimum requirements established per NFPA 1981	Surface Fire Trucks; Underground Rescue Cart
General Plant Emergency Equipment		
Emergency Lighting	For employee evacuation, and fire/spill containment; linked to main power supply, and selectively linked to back up diesel power supply and/or battery-backed power supply	Waste Handling Building (Building 411); TRUPACT Maintenance Building (Building 412), Exhaust Shaft Filter Building (Building 413) NFB (Building 416), and SRB (Building 417)
Backup Power Sources	A minimum of two diesel generators, and battery-powered uninterruptible power supply (UPS)	Generators are located on the surface. UPS is located at the essential loads

Waste Isolation Pilot Plant
Hazardous Waste Facility Permit
Attachment D
October 2023

Equipment	Description and Capabilities	Location
Emergency Hoist	Hoist in Air Intake Shaft	Air Intake Shaft (Building 361)
Emergency Showers	For emergency flushing of chemical contact or injury	Waste Handling Building (Building 411) is served by the decontamination shower trailer located north of Building 411, in front of Building 952, between Buildings 243 and 455; and CAAs (Building 474A)
Emergency Eyewash Equipment	For emergency flushing of affected eyes	Waste Handling Building (Building 411, RH Bay, Site Derived Waste Area, Waste Shaft Collar, and Room 108 TRUPACT III only), TRUPACT Maintenance Building (Building 412), Exhaust Shaft Filter Building (Building 413), NFB (Building 416), SRB (Building 417), CAAs, and SAAs
Overpack containers for TRU Mixed Waste	85 Gallon drums SWBs TDOP	Warehouse Annex (Building 481)
Aquaset or Cement	Material for solidification of liquid waste generated as a result of firefighting water or decontamination solutions	Surface Connex A, located south of Waste Handling Building (Building 411)
TDOP Upender	Upender facilitates overpacking standard waste boxes into TDOPs	Waste Handling Building (Building 411)
Nonhazardous Decontaminating Agents	For decontamination of surfaces, equipment, and personnel	Waste Handling Building (Building 411); Surface Connex A, located south of Building 411

FIGURES

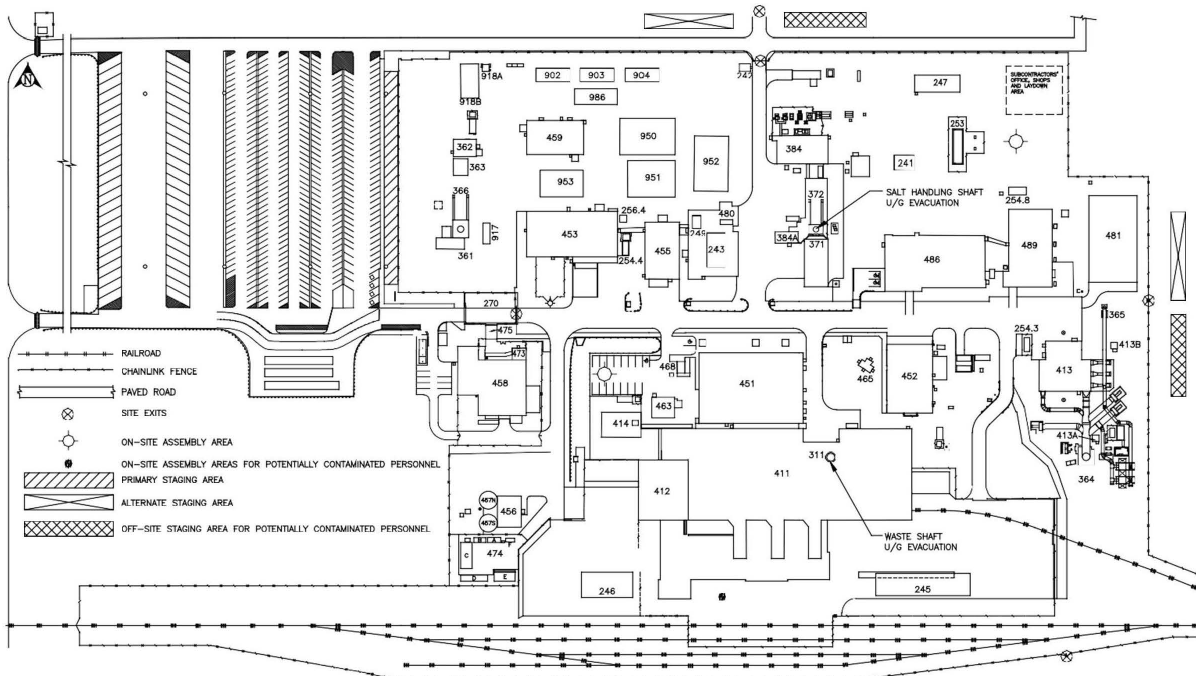

Figure D-1
 WIPP Surface Structures

BLDG./FAC. #	DESCRIPTION	BLDG./FAC. #	DESCRIPTION	BLDG./FAC. #	DESCRIPTION	BLDG./FAC. #	DESCRIPTION
#241	EQUIPMENT SHED	#362	AIR INTAKE SHAFT/HOIST HOUSE	#457S	WATER TANK 25-D-001A	#903	TRAILER
#242	GUARDSHACK	#363	AIR INTAKE SHAFT/WINCH HOUSE	#458	GUARD AND SECURITY BUILDING	#904	TRAILER
#243	SALT HAULING TRUCKS SHELTER	#364	EFFLUENT MONITORING INSTRUMENT SHED A	#459	CORE STORAGE BUILDING	#917	AIS MONITORING
#244	TRUPAC TRAILER SHELTER	#365	EFFLUENT MONITORING INSTRUMENT SHED B	#463	COMPRESSOR BUILDING	#918A	VOC AIR MONITORING STATION
#245	MoO STORAGE SHELTER	#366	AIR INTAKE SHAFT HEADFRAME	#465	AUXILIARY AIR INTAKE	#918B	VOC LAB TRAILER
#246	MoO STORAGE SHELTER	#371	SALT HANDLING SHAFT	#468	TELEPHONE HUT	#950	WORK CONTROL TRAILER
#251	15.9 KV SWITCHGEAR 25P-SWG15/1	#372	SALT HANDLING SHAFT HEADFRAME	#473	ARMORY BUILDING	#951	PROCUREMENT/PURCHASING TRAILER
#254.1	AREA SUBSTATION NO.1 25P-SW15.1	#373	SALT HANDLING SHAFT HOISTHOUSE	#474	HAZARDOUS WASTE STORAGE FACILITY	#952	TRAILER
#254.2	AREA SUBSTATION NO.2 25P-SW15.2	#384A	MINING OPERATIONS	#474A	HAZARDOUS WASTE STORAGE BUILDING	#953	MODULAR OFFICE COMPLEX
#254.3	AREA SUBSTATION NO.3 25P-SW15.3	#411	WASTE HANDLING BUILDING	#474B	HAZARDOUS WASTE STORAGE BUILDING	#986	PUBLICATIONS & PROCEDURES TRAILER
#254.4	AREA SUBSTATION NO.4 25P-SW15.4	#412	TRUPAC MAINTENANCE BUILDING	#474C	OIL & GREASE STORAGE BUILDING	SWR NO.6	SWITCHRACK NO. 6
#254.5	AREA SUBSTATION NO.5 25P-SW15.5	#413	EXHAUST SHAFT FILTER BUILDING	#474D	GAS BOTTLE STORAGE BUILDING	SWR NO.7,7A,7E	SWITCHRACK NO. 7, 7A, 7B
#254.6	AREA SUBSTATION NO.6 25P-SW15.6	#413A	MONITORING STATION A	#474E	HAZARD MATERIAL STORAGE BUILDING	SWR NO.7C	SWITCHRACK NO. 7C
#254.7	AREA SUBSTATION NO.7 25P-SW15.7	#413B	MONITORING STATION B	#474F	WASTE OIL RETAINER	SWR NO.10	SWITCHRACK NO. 10
#254.8	AREA SUBSTATION NO.8 25P-SW15.8	#414	WATER CHILLER FACILITY & BLDG	#475	GATEHOUSE	SWR NO.11	SWITCHRACK NO. 11
#254.9	480V SWITCHGEAR (25P-SWG04/9)	#451	SUPPORT BUILDING	#480	VEHICLE FUEL STATION	SWR NO.12	SWITCHRACK NO. 12
#255.1	BACK-UP DIESEL GENERATOR #1 25-PE 503	#452	SAFETY & EMERGENCY SERVICES FACILITY	#481	WAREHOUSE ANNEX	SWR NO.15	SWITCHRACK NO. 15
#255.2	BACK-UP DIESEL GENERATOR #2 25-PE 504	#453	WAREHOUSE/SHOPS BUILDING	#489	ENGINEERING BUILDING		
#256.4	SWITCHBOARD #4 (25P-SB004/4)	#455	AUXILIARY WAREHOUSE BUILDING	#H-16	TRAINING BUILDING		
#270	ACCESS CONTROL POINT SHELTER	#456	WATER PUMPHOUSE	#902	SANDIA TEST WELL		
#311	WASTE SHAFT	#457N	WATER TANK 25-D-001B		TRAILER		
#351	EXHAUST SHAFT						
#361	AIR INTAKE SHAFT						

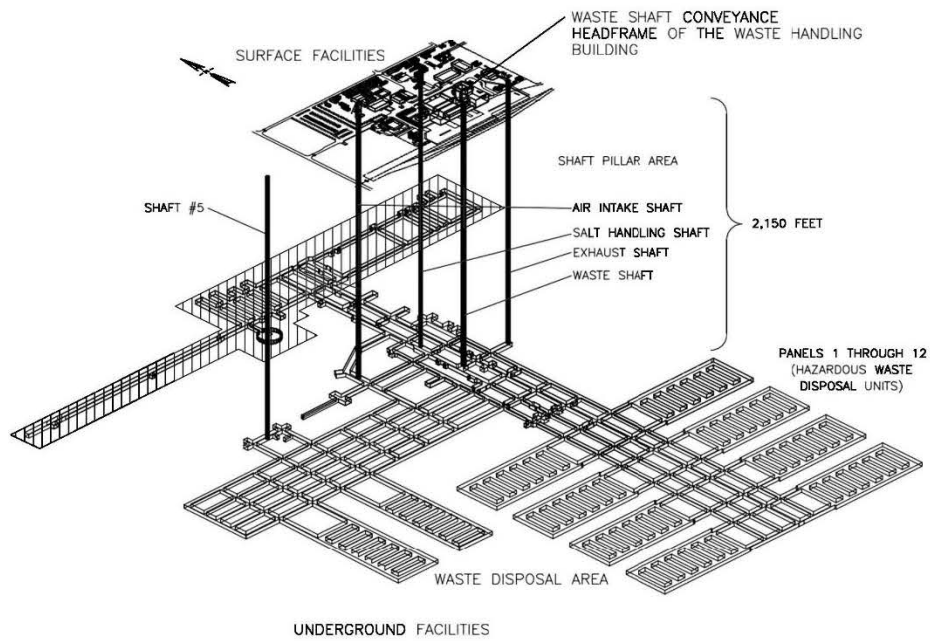

Figure D-2
Spatial View of the WIPP Facility

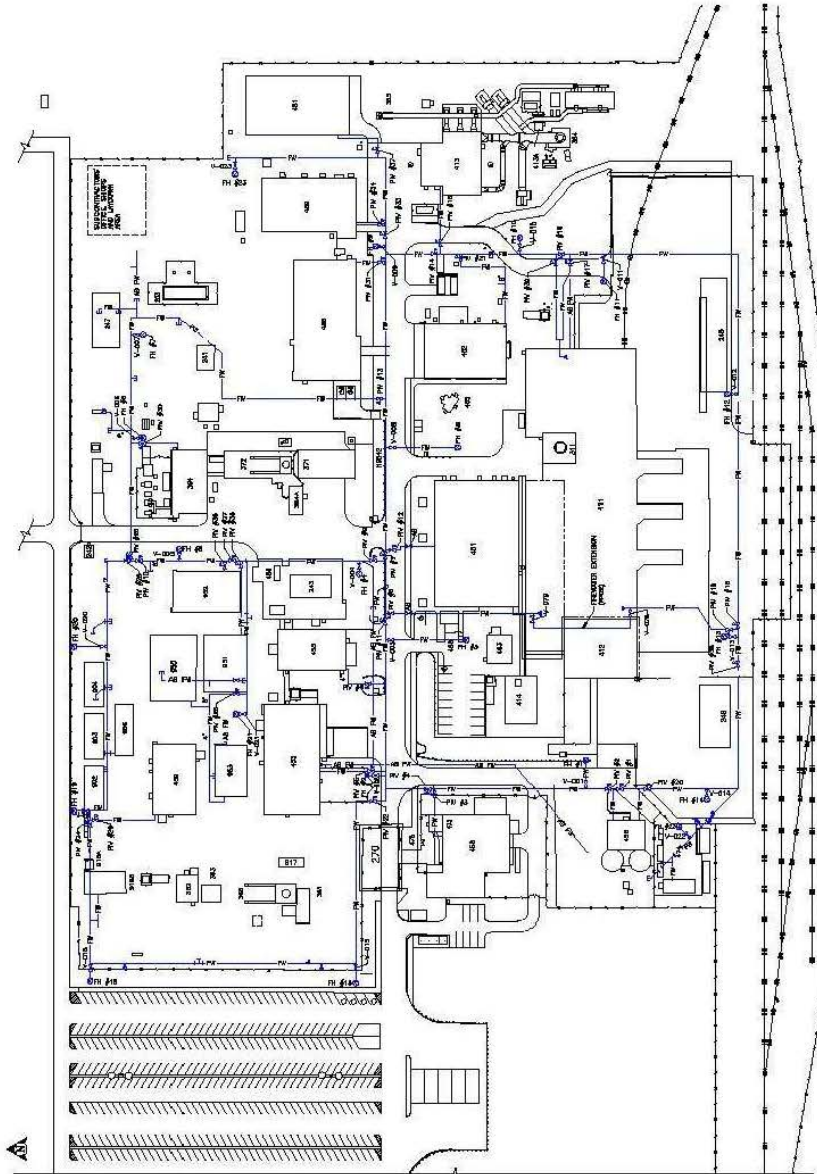

Figure D-4
Fire-Water Distribution System

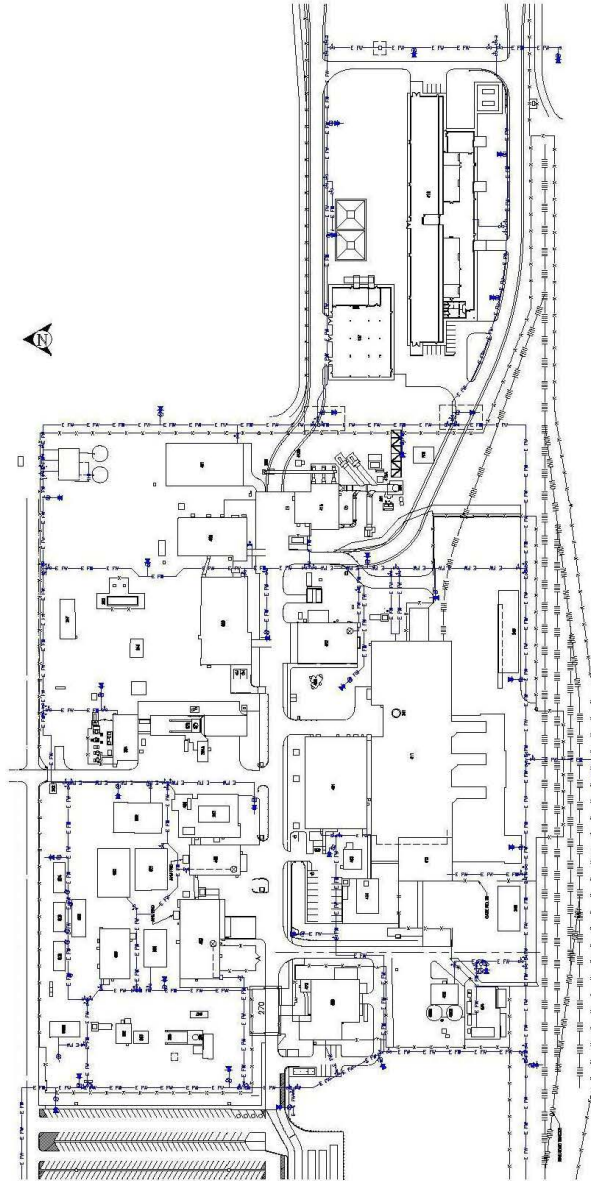

Figure D-4-NFB
Fire-Water Distribution System with Building 416

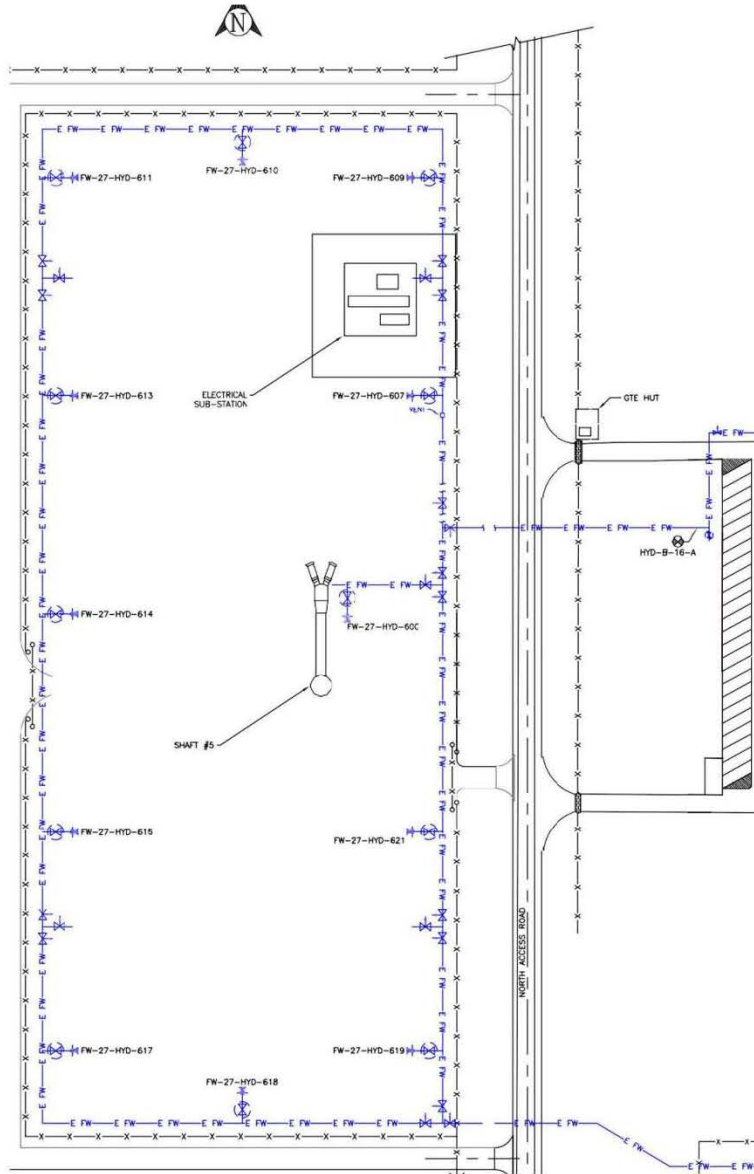
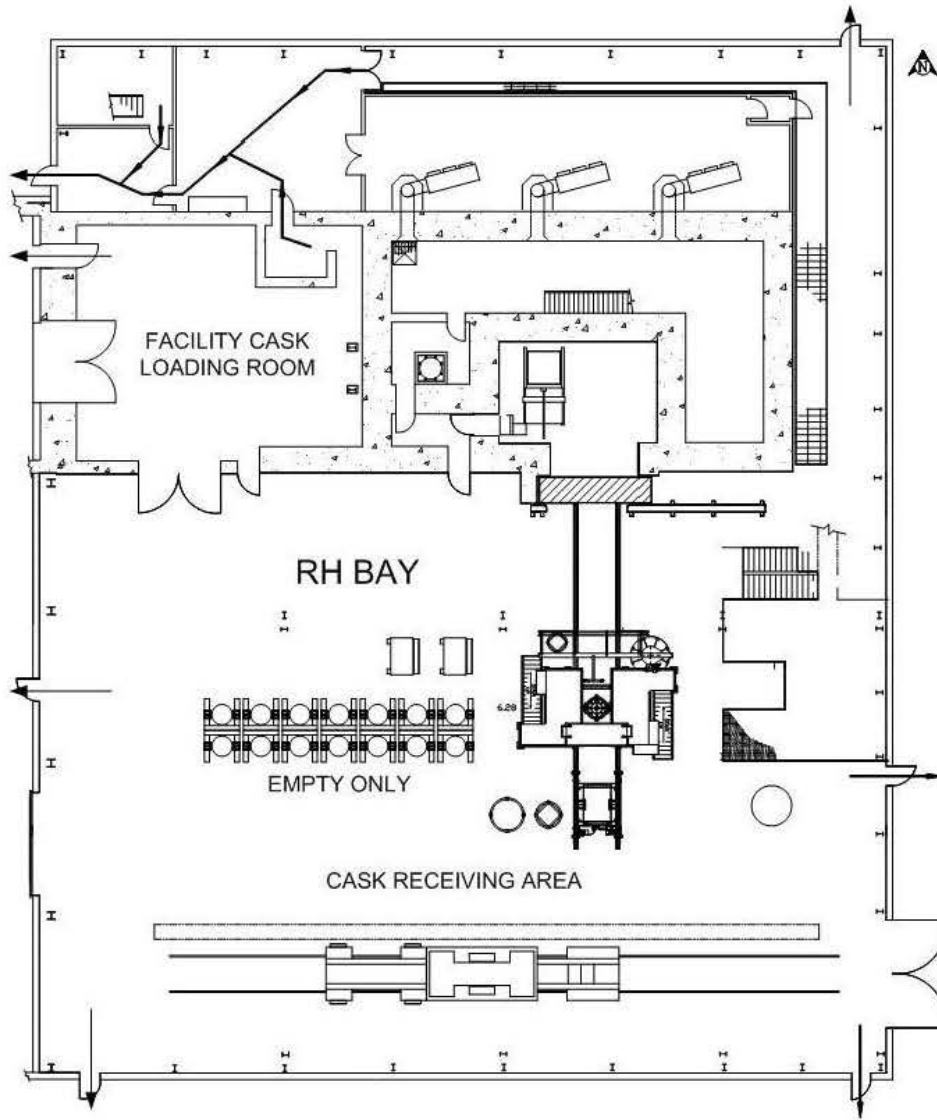

Figure D-4-S#5
Fire-Water Distribution System (with S#5)



This illustration for
Information Purposes Only

Figure D-5
RH Bay Evacuation Routes

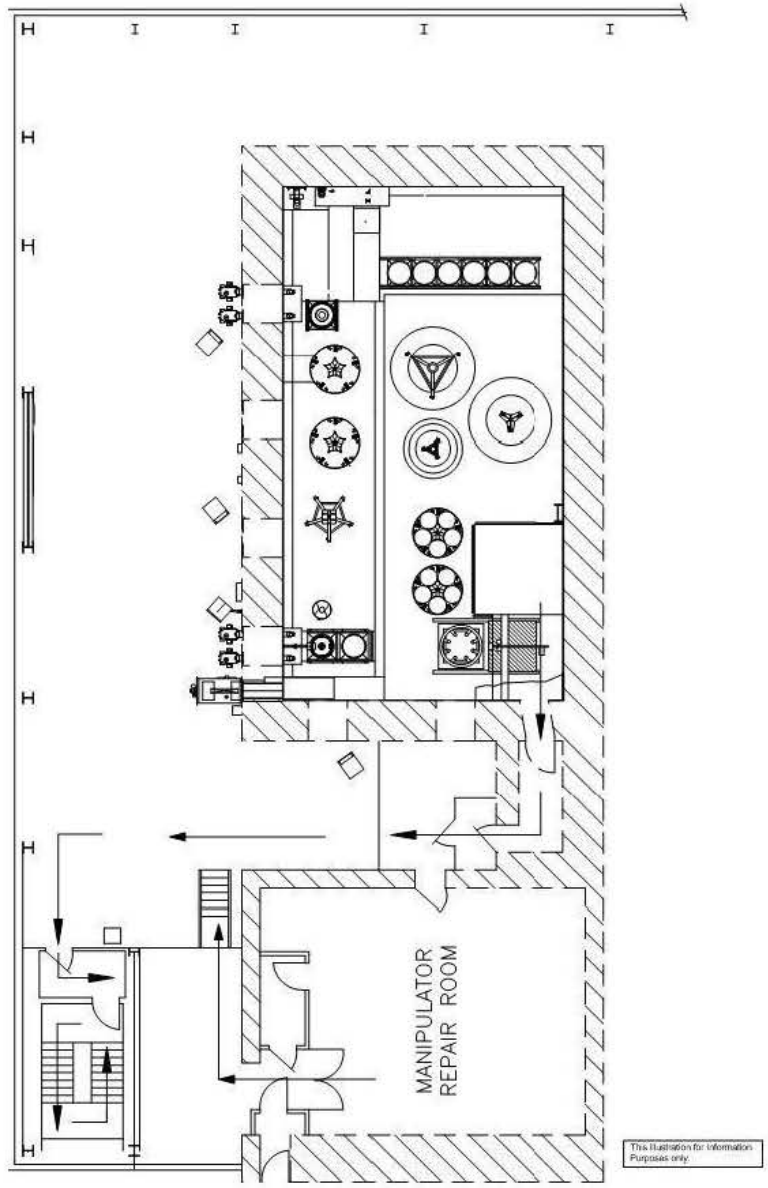

Figure D-6
RH Bay Hot Cell Evacuation Route

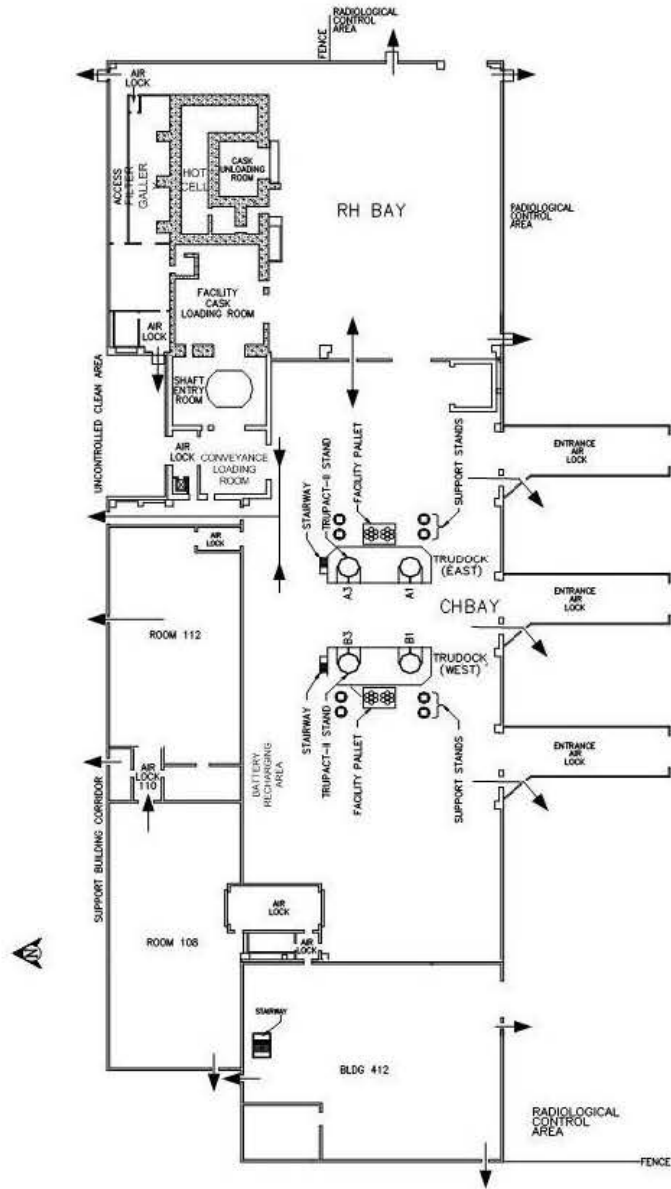

Figure D-7
Evacuation Routes in the Waste Handling Building

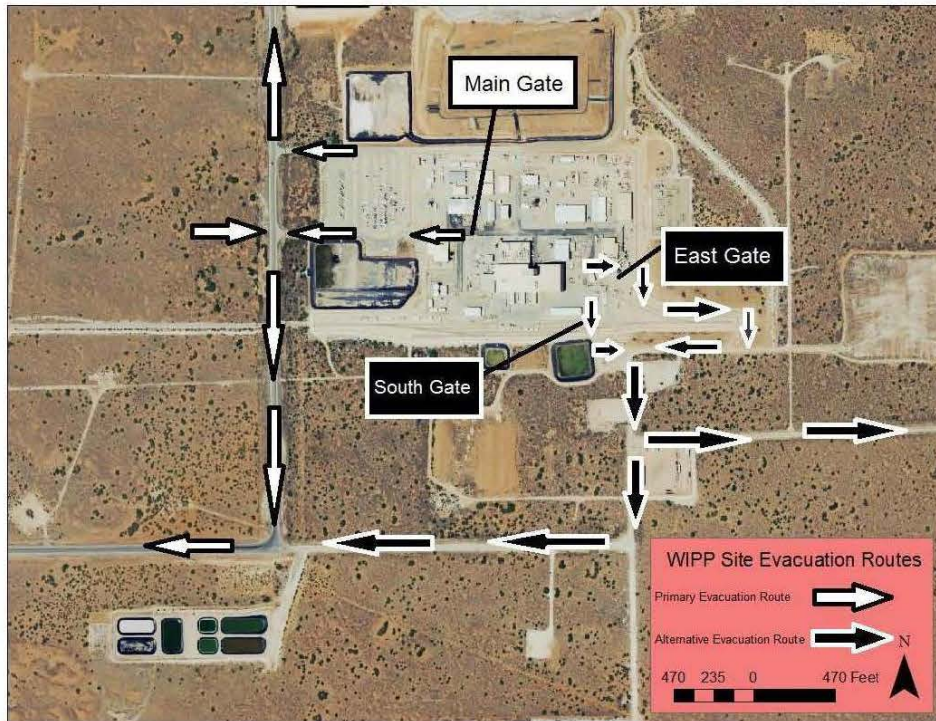

Figure D-8
WIPP Site Evacuation Map

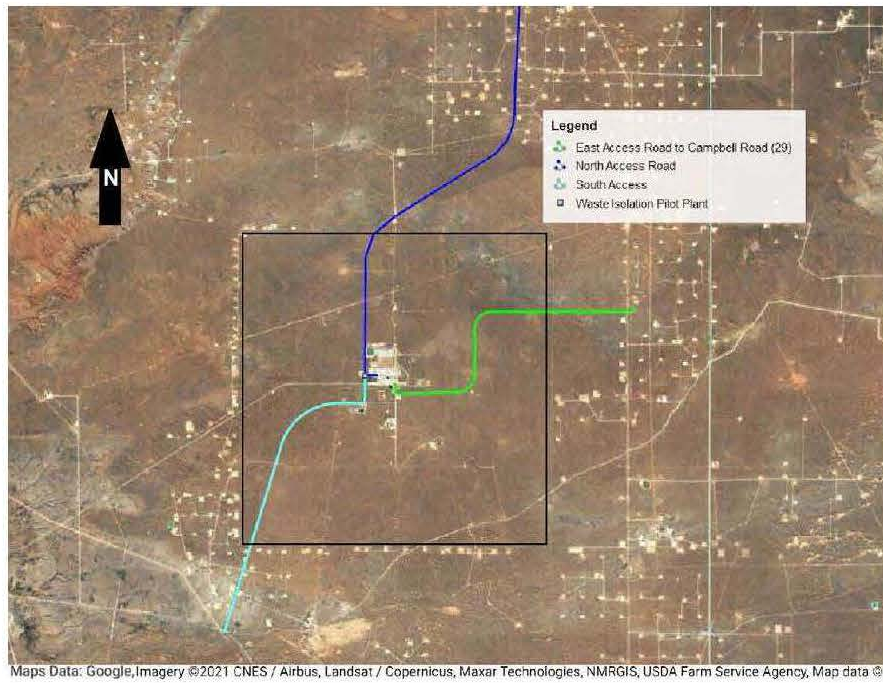

Figure D-8a
WIPP Site Evacuation Routes