

For assistance in accessing this document, please contact ghgreporting@epa.gov.

Technical Review of Subpart RR MRV Plan for Aker Plant

December 2025

Contents

1	Overview of Project	3
2	Evaluation of the Delineation of the Maximum Monitoring Area (MMA) and Active Monitoring Area (AMA)	4
3	Identification of Potential Surface Leakage Pathways	5
4	Strategy for Detecting and Quantifying Surface Leakage of CO ₂ and for Establishing Expected Baselines for Monitoring.....	9
5	Considerations Used to Calculate Site-Specific Variables for the Mass Balance Equation.....	14
6	Summary of Findings	17

Appendices

Appendix A: Submissions and Responses to Requests for Additional Information

This document summarizes the U.S. Environmental Protection Agency's (EPA's) technical evaluation of the Greenhouse Gas Reporting Program (GHGRP) subpart RR Monitoring, Reporting, and Verification (MRV) plan submitted by Midcoast G&P (East Texas) L.P. (Midcoast G&P) for Aker Plant (Aker) located in Freestone County, Texas. Note that this evaluation pertains only to the subpart RR MRV plan for Aker, and does not in any way replace, remove, or affect Underground Injection Control (UIC) permitting obligations. Furthermore, this decision is applicable only to the MRV plan and does not constitute an EPA endorsement of the project, technologies, or parties involved.

1 Overview of Project

The introduction of the MRV plan states that Midcoast G&P operates an acid gas injection well in Aker (Woodbine H₂S Disposal) Field. The Aker Gas Injection No. 1 well (Aker No. 1) API No. 42-161-34475 received its UIC Class II injection permit from the Texas Railroad Commission (TRRC) on June 22, 2010, with a Permit Amendment (Permit No. 13099 Amendment) approved November 15, 2023. Aker states that Aker No. 1 has injected into the Woodbine Formation since April 2012.

The MRV plan explains that Aker No. 1 was developed to dispose of oil and gas waste from Aker Plant in Freestone County, Texas. Located in a rural agricultural area, the plant is approximately 6.2 miles northeast of Streetman, TX. Aker No. 1 is permitted for 9 million standard cubic feet per day (MMscf/d) of treated acid gas (TAG) from Aker Plant with a maximum allowable surface injection pressure (MASIP) of 1,800 pounds per square inch gauge (psig). Aker states that it intends to inject into Aker No. 1 for approximately 12 years at up to a maximum rate of 9 MMscf/d.

Section 2 of the MRV plan outlines the geologic context, planned injection volumes, and reservoir modeling conducted by Lonquist Sequestration, LLC (Lonquist), for Aker No. 1. Aker injects an acid gas mixture of CO₂ and H₂S into the Woodbine Formation by way of Aker No. 1 for sequestration. Aker Plant and Aker No. 1 are designed and operated to prevent leaks from mechanical systems and the injection zone, safeguarding the Underground Source of Drinking Water (USDW) and preventing surface releases. The Woodbine Formation, the designated injection zone, is protected by multiple overlying formations that ensure subsurface containment. The Eagle Ford Shale serves as the Upper Confining Zone (UCZ), with the Maness Shale providing the Lower Confining Zone (LCZ).

The acid gas stream injected into Aker No. 1 is separated from the production gas stream from the amine unit at Aker Plant in Freestone County, TX. The acid gas stream is measured, sampled, and pumped from the amine unit to the nearby Aker No. 1 well and injected into the disposal formation. The acid gas stream from Aker Plant is the only source of CO₂ injected into Aker No. 1. An image of Aker and the surrounding facilities is presented in Figure 2 in the MRV plan.

The description of the project provides the necessary information for 40 CFR 98.448(a)(6).

2 Evaluation of the Delineation of the Maximum Monitoring Area (MMA) and Active Monitoring Area (AMA)

As part of the MRV plan, the reporter must identify and delineate both the maximum monitoring area (MMA) and active monitoring area (AMA), pursuant to 40 CFR 98.448(a)(1). Subpart RR defines the maximum monitoring area as “the area that must be monitored under this regulation and is defined as equal to or greater than the area expected to contain the free phase CO₂ plume until the CO₂ plume has stabilized plus an all-around buffer zone of at least one-half mile.” Subpart RR defines the active monitoring area as “the area that will be monitored over a specific time interval from the first year of the period (n) to the last year in the period (t). The boundary of the active monitoring area is established by superimposing two areas: (1) the area projected to contain the free phase CO₂ plume at the end of year t, plus an all-around buffer zone of one-half mile or greater if known leakage pathways extend laterally more than one-half mile; (2) the area projected to contain the free phase CO₂ plume at the end of year t + 5.” See 40 CFR 98.449.

Regarding the reservoir modeling that was conducted for Aker, Section 2.14 of the MRV plan states that dynamic plume modeling was performed in Rock Flow Dynamic’s (RFD) tNavigator version 24.4. The model was created using a structure contour map of the top of the Woodbine injection interval and a type log of the injection well to support the permitting of Aker No. 1 for acid gas injection. The modeling predicts well injectivity, pressure response, and acid gas plume migration. The target injection zone is the Woodbine Formation, located at a depth between 3,903 feet (ft) to 4,337 ft true vertical depth (TVD). Aker states that the Petra software package was used to construct a geologic model for the target formation. Within Petra, formation top contours were generated for the Woodbine Formation and subsequently brought into tNavigator to depict the geological structure.

Section 2.15 of the MRV plan explains that the simulation model, which began in April 2012, was run for 49.667 years, comprising 12.667 years of historical injection and 12 years of anticipated injection, and was then succeeded by 25 years of density drift. Throughout the historical 12.667-year injection period, a variable injection rate is injected based on the reported monthly injection from the annually submitted H-10 forms. Then, a maximum rate of 9 MMscf/d is injected for 12 years of anticipated injection, yielding the largest estimate of the plume size. After the 24.667-year injection period, when Aker No. 1 ceases injection, the density drift of the plume continues until the plume stabilizes 25 years later. The maximum plume extent during the 24.667-year injection period is shown in Figure 27 of the MRV plan and the final extent after 25 years of density drift after injection ceases is shown in Figure 28 of the MRV plan.

Section 3.1 of the MRV plan states that the MMA is defined as equal to or greater than the area expected to contain the free-phase CO₂ plume until the plume has stabilized, plus a surrounding buffer zone of at least one-half mile, as shown in Figure 32 of the MRV plan. Numerical simulation was used to predict the size and drift of the plume. Reservoir modeling was used to determine the areal extent and density drift of the plume, as described previously. The model considers the following:

- Offset well logs to estimate geologic properties
- Petrophysical analysis to calculate the heterogeneity of the rock
- Geological interpretations to determine faulting and geologic structure
- Offset injection history to adequately predict the density drift of the plume

Aker states that plume stabilization is deemed to have occurred when the rate of growth or positional change of the plume size year after year becomes indiscernible. The stabilization of the plume is determined by the model output, when the areal growth rate drops below 0.25% in size per year.

Section 3.2 of the MRV plan states that the AMA boundary is established by superimposing two areas: (1) the anticipated plume boundary at the end of injection operations, which is year 12 (t), plus a buffer zone of one half mile, with (2) the area projected to contain the free-phase CO₂ plume at the end of year (t + 5). The AMA is represented by the dashed green boundary in Figure 32 of the MRV plan.

Aker states that at cessation of injection operations in year 12, the anticipated areal extent of the plume will be approximately 3,263 acres, and the AMA's extent is 6,417 acres. After an additional 25 years of density drift when the plume has stabilized, the predicted areal extent of the MMA is 8,364 acres. Figure 32 of the MRV plan shows the plume area at the end of 25 years (stabilization) represented by the red line area, plus a one-half mile buffer represented by the dashed red line (MMA). As a result of the small difference between the AMA and the MMA, Aker has elected to set the AMA equal to the MMA.

The delineations of the MMA and AMA are acceptable per the requirements in 40 CFR 98.448(a)(1). The MMA and AMA described in the MRV plan are clearly delineated in the plan and are consistent with the definitions in 40 CFR 98.449.

3 Identification of Potential Surface Leakage Pathways

As part of the MRV plan, the reporter must identify potential surface leakage pathways for CO₂ in the MMA and the likelihood, magnitude, and duration of surface leakage of CO₂ through these pathways pursuant to 40 CFR 98.448(a)(2). Aker identified the following as potential leakage pathways in Section 5 of their MRV plan that required consideration:

- Surface equipment
- Existing wells within the MMA
- Future drilling in the MMA
- Faults and fractures
- Confining zones
- Natural or induced seismicity

A summary table of Aker's characterization of the likelihood, magnitude, and timing of surface leakage through the potential leakage pathways can be found in Table 12 of the MRV plan and is copied below.

Potential Leakage Pathway	Likelihood	Magnitude	Timing
Surface Equipment	Possible during injection operations.	Low. SCADA systems will detect leaks and execute safety shutdown procedures.	During active injection.
Existing wells within the MMA	Low. Twenty-seven wells penetrate the Upper Confinement within the MMA. Only seven of these wells are within the stabilized plume.	Low. Multiple upper confining intervals and the TRRC SWR 13 completion requirements mitigate the risk of CO ₂ migration to USDW and surface releases.	During active injection and until the plume stabilizes 25 years after injection ceases.
Future wells within the MMA	Low. The area is active with oil and gas production. Most well locations within the MMA have already been drilled.	Low. TRRC requires that any new wells penetrating the injection intervals be constructed in compliance with SWR 13 to prevent migration of CO ₂ . Additionally, there are multiple confining zones above the injection zone.	During active injection and until the plume stabilizes 25 years after injection ceases.
Faults and fractures	Low. No faults or fractures were identified in the Area of Review.	Low. Multiple Confining Zones should contain any leakage that would migrate through faulting.	During active injection and until the plume stabilizes 25 years after injection ceases.
Confining Zones	Low. The Confining Zones have sufficient thickness, continuity, and confining characteristics.	Low. Leakage out of the injection interval is unlikely due to multiple Confining Zones.	During active injection and until the plume stabilizes 25 years after injection ceases.
Natural or induced seismicity	Low. A review of seismic data shows no earthquakes of magnitude 2.0 or greater within a 9.08 km radius, indicating a low probability of a seismic event.	Low. The Confining Zones should prevent migration out of the injection intervals in the event of induced seismicity.	During active injection and until the plume stabilizes 25 years after injection ceases.

Magnitude Assessment Description
Low - categorized as little to no impact to safety, health and the environment and the costs to mitigate are minimal.
Medium - potential risks to USDW and for surface releases do exist, but circumstances can be easily remediated.
High - danger to USDW and significant surface release may exist, and if occurs this would require significant costs to remediate.

3.1 Leakage from Surface Equipment

Section 4.1 of the MRV plan states that Aker Plant and Aker No. 1 have been in operation since 2010. The pipeline and wellhead are potential sources of leakage during injection operations, as the flanged connections and valves are the most likely failure points of the surface equipment. Additionally, Aker states that damage may occur if any of the surface equipment is compromised due to an accident, corrosion, or a natural disaster, resulting in the release of the injectate. Aker also states that gas detectors for H₂S are installed at key locations within the facility, as shown in the site plan in Figures 41 and 42 and Appendix B of the MRV plan.

Thus, the MRV plan provides an acceptable characterization of CO₂ leakage that could be expected from surface equipment.

3.2 Leakage through Wells within the MMA

Existing Wells Within the MMA

Section 4.2 of the MRV plan states that Aker No. 1 is designed to prevent migration from the injection interval to the surface through a special casing and cementing design. The annular spaces between the injection tubing and the long string casing are filled with an inert corrosion-inhibiting fluid as a further safety measure. A successful mechanical integrity test (MIT) is required under TRRC's 16 Texas Administrative Code (TAC) §3.9 and §3.46 before injection operations can begin. To maintain compliance, Class II AGI wells must undergo an MIT at least once every five years. A successful MIT demonstrates that there are no significant leaks in the casing, tubing, or packer and that the well is properly isolated from the USDWs. An unsuccessful MIT would indicate the potential of a leak; the well would be isolated, and the leak mitigated to prevent leakage of the injectate into another formation or to the atmosphere.

The MRV plan asserts that research of the MMA yielded 35 oil and gas wells in the area. In review of these wells, 27 penetrate the upper confinement. The remaining 8 wells were either too shallow to penetrate the upper confinement or had expired permits and were never drilled. Furthermore, the plan maintains that most of the drilling activity targets the Cotton Valley, Bossier, and Rodessa formations, which occur at depths of between 10,000 ft and 11,500 ft, which is significantly deeper than the Woodbine Formation. Aker states that well completions at this depth will typically have two casing strings cemented through the Woodbine, providing an additional layer of safety against possible corrosion.

Future Drilling

The MRV plan states that new wells drilled within the MMA will be required to comply with TAC Title 16, Part 1, Chapter 3, Section 3.13. For any wells drilled for oil or gas with surface and intermediate casing, the regulations require casing to be set at specific depths and cemented adequately to isolate productive zones, unusable water zones, and other subsurface formations. Aker will monitor any new

permits and coordinate with the operator to ensure that if a proposed well will intersect the CO₂ plume that it will be constructed in a manner to prevent migration above the injection interval.

Freshwater Wells

The MRV plan states that a groundwater well search in the area identified 16 groundwater wells within the MMA, identified by the Texas Water Development Board (TWDB). The deepest of these wells has a total depth of 163 ft, which is significantly shallower than the UCZ of the Woodbine injection interval.

Aker states that the surface casing for Aker No. 1 is set at a depth of 506 ft and is cemented to surface, sufficiently below the Base of Usable Quality Water at 425 ft, designed to isolate and protect the shallow freshwater aquifers, consistent with applicable TRRC regulations for this area. The wellbore casings and cement also prevent CO₂ leakage to the surface along the borehole. Aker believes that leakage of CO₂ from the Woodbine Formation to the groundwater wells is unlikely.

Thus, the MRV plan provides an acceptable characterization of CO₂ leakage that could be expected through wells in the MMA.

3.3 Leakage through Faults and Fractures

Section 4.3 of the MRV plan states that no faults were identified within the confinement or injection zones in the MMA. With more than 10 years of operating history in the area, without incident, Aker believes that leakage of CO₂ from the Woodbine Formation to the groundwater wells is unlikely.

Thus, the MRV plan provides an acceptable characterization of the likelihood of CO₂ leakage that could be expected through faults and fractures.

3.4 Leakage through the Confining Layers

Section 4.4 of the MRV plan states the Eagle Ford Shale, a well-known competent barrier, provides upper confinement for the Woodbine interval, preventing CO₂ leakage. Its regional continuity, high clay content, and effective sealing properties make it an ideal upper confining layer.

Additionally, the MRV plan states that Maness Shale underlies and confines the Woodbine. It is stratigraphically equivalent to the Eagle Ford Shale in areas where the Woodbine is absent. Like the Eagle Ford Shale, the Maness Shale has robust sealing properties that effectively prevent fluid migration or leakage.

Thus, the MRV plan provides an acceptable characterization of CO₂ leakage that could be expected through the confining layers.

3.5 Leakage from Natural or Induced Seismicity

The MRV plan states that the USGS indicates that Aker No. 1 lies in a seismically quiet region of the U.S. A review of the Bureau of Economic Geology's (BEG) TexNet catalog and the USGS Advanced National Seismic System websites showed no natural or induced seismic activity within 25 km (15.5 miles) of Aker No. 1.

Although the well is outside the area of review, a search was conducted using a 100 km (62.1 mi) radius in the USGS database to return the closest recorded seismic events for reference purposes. The closest occurrence was 83 km (51.6 mi) west-northwest from Aker No. 1. Therefore, Aker concluded that its injection operations have not yielded any observable seismic events in the past, nor would ongoing operations be expected to induce any seismic events.

Thus, the MRV plan provides an acceptable characterization of CO₂ leakage that could be expected from natural or induced seismicity. In summary, the MRV plan provides an acceptable characterization of potential CO₂ leakage pathways as required by 40 CFR 98.448(a)(2).

4 Strategy for Detecting and Quantifying Surface Leakage of CO₂ and for Establishing Expected Baselines for Monitoring

40 CFR 98.448(a)(3) requires that an MRV plan contains a strategy for detecting and quantifying any surface leakage of CO₂, and 40 CFR 98.448(a)(4) requires that an MRV plan includes a strategy for establishing the expected baselines for monitoring potential CO₂ leakage. Sections 5 and 7 of the MRV plan discuss the strategies that Aker will employ for detecting and quantifying surface leakage of CO₂ through the pathways identified in the previous section to meet the requirements of 40 CFR §98.448(a)(3). Aker states that as the injectate stream contains both H₂S and CO₂, the H₂S will be a proxy for CO₂ leakage; therefore, the monitoring systems in place to detect H₂S will also indicate the release of CO₂. Monitoring will occur during the planned 12-year injection period or cessation of injection operations, plus a proposed 25-year post-injection period until the plume has stabilized. A summary table of Aker's detection strategies can be found in Table 13 of the MRV plan and is reproduced below.

Leakage Pathway	Monitoring Method	Frequency
Surface Equipment	Fixed H ₂ S monitors throughout the Aker Plant and Aker No. 1 well	Continuous
	Visual inspections	Daily
	SCADA continuous monitoring of the Aker Plant and Aker No. 1 well	Continuous
Existing Wells	SCADA Continuous Monitoring at the Aker No. 1 well	Continuous
	Mechanical Integrity Test of the Aker No. 1 well	Annually
	Visual Inspections	As needed
	Annual soil gas sampling at well locations within the MMA	Annually
Drilling through MMA	Compliance with TRRC regulations	During operations
	Monitor Drilling Activity	During operations
Faults and Fractures	SCADA Monitoring at the Aker No. 1 well (volumes and pressures)	Continuous
Upper Confining Zone	SCADA Monitoring at the Aker No. 1 well (volumes and pressures)	Continuous
Natural or induced seismicity	Seismic monitoring station	Continuous

4.1 Detection of Leakage from Surface Equipment

The plan states that Aker Plant and Aker No. 1 are designed and constructed to inject CO₂ and H₂S according to industry best practices and standards to minimize potential leakage points. Operations at Aker Plant are monitored and controlled with Distributed Control Systems (DCS) and Supervisory Control and Data Acquisition (SCADA) systems providing 24/7 operational supervision. Baseline atmospheric H₂S/CO₂ concentrations are to be established prior to commencing injection volumes reported under this MRV plan. Ambient H₂S detectors are located throughout Aker Plant and near Aker No. 1 with local alarms. They are connected to the SCADA system for continuous monitoring.

The MRV plan also states that Aker field personnel are to conduct routine inspections of detectors, gauges, and leak indicators, such as vapor plumes and ice formations. In addition, the fixed in-field H₂S-specific devices have a high (Hi) alarm setpoint at 10 ppm and a Hi-Hi setpoint at 20 ppm. In the event of an alarm, personnel are trained to follow the H₂S Contingency Plan for safety and operational matters.

Pressures, temperatures, and flow rates through the surface equipment are continuously monitored during operations.

Table 13 of the MRV plan provides a detailed characterization of detecting CO₂ leakage that could be expected from surface equipment. Thus, the MRV plan provides adequate characterization of Aker's approach to detect potential leakage from surface equipment as required by 40 CFR 98.448(a)(3).

4.2 Detection of Leakage through Existing Wells within the MMA

The MRV plan states that Aker will continuously monitor and collect injection volumes, pressures, and temperatures through their SCADA systems for Aker No. 1. This data will be reviewed by qualified personnel and will follow response and reporting procedures when the data is outside of the normal operating range. A change of injection or annular pressure would indicate the presence of a possible leak and would be thoroughly investigated. Additionally, an unsuccessful MIT would indicate the potential of a leak. Upon an unsuccessful MIT, the well would be isolated, the circumstance would be investigated, and the leak would be mitigated.

Aker No. 1 Injection Well

The MRV plan states that, under Permit Amendment 13099, Aker agreed to perform an annual MIT on Aker No. 1. Monitoring equipment will be installed in the well, including traditional surface-pressure monitoring on the tubing, casing, and surface casing. Additionally, the operator will ensure the continuous monitoring and collection of data, including injection volume, temperature, pressure, and gas composition data for Aker No. 1. The data will be recorded via SCADA systems and reviewed by qualified personnel who will respond according to designated response and reporting procedures if set performance limits are exceeded. A temperature and pressure gauge will be placed at the wellhead in the injection stream, and a pressure gauge will be placed on the casing annulus. Changes in annular pressure would signal the presence of a possible leak. The Aker No. 1 wellsite will also be equipped with a volumetric flow meter, ESD valve, and gas monitors.

Oil and Gas Wells in the MMA

The MRV plan states that there are 35 oil and gas wells within the MMA, of which 27 penetrate the upper confining zone (UCZ). The remaining 8 wells were either too shallow to penetrate the UCZ or had expired permits or were never drilled. Aker operates two observation wells within the injection plume that are completed in the Woodbine Formation. Aker will monitor these two observation wells for wellhead pressure and any irregularities.

Groundwater Wells within the MMA

The MRV plan states that Aker will perform baseline and annual groundwater sampling from well No. 3907403 in the northern portion of the stabilized plume. These water samples will be analyzed by a third-party laboratory for key constituents specific to the acid gas stream, such as CO₂, H₂S, pH,

temperature, and other standard laboratory measurements. Aker states that any significant variances found in future samples will be evaluated to identify the possible leakage of CO₂.

Future Wells within the MMA

According to the MRV plan, Aker will routinely monitor the TRRC site for permits and drilling activities in the MMA, and for operators' compliance with TRRC SWR Rule 13 (Casing, Cementing, Drilling, Well Control, and Completion Requirements), 16 TAC §3.13. Aker states that operators in Freestone and Navarro Counties and Districts 5 and 6, where Aker No. 1 is located, must comply with TRCC SWR Rule 13, which requires that oil and gas operators set steel casing and cement the well as follows:

- Above and across all formations permitted for injection under TRRC Rule 9.
- Immediately above all formations permitted for injection under TRRC Rule 46 for any proposed well within a ¼ mi radius of an injection well.

Additionally, SWR Rule 13 also requires operators to case and cement both above and across all potential flow zones and zones containing corrosive formation fluids, which makes the likelihood of leakage from possible new wells low.

Table 13 of the MRV plan provides a detailed characterization of detecting CO₂ leakage that could be expected through existing wells within the MMA. Thus, the MRV plan provides adequate characterization of Aker's approach to detect potential leakage through existing wells within the MMA as required by 40 CFR 98.448(a)(3).

4.3 Detection of Leakage through Faults, Fractures, and Confining Zones

The MRV plan states that Aker is operating and will continue to operate Aker No. 1 at injection pressures below the permit limits approved by the TRRC, thereby minimizing the potential for induced seismicity. Aker will use its SCADA systems to monitor these operating set points. If those limits are exceeded, alerts are to be triggered to note the operating events. Field personnel will review the data associated with the alert and determine if there has been a risk to the confining seal of the sequestering formation and will take prudent actions as necessary based on the findings.

Table 13 of the MRV plan provides a detailed characterization of detecting CO₂ leakage that could be expected through faults, fractures, and confining zones. Thus, the MRV plan provides adequate characterization of Aker's approach to detect potential leakage through faults, fractures, and confining zones as required by 40 CFR 98.448(a)(3).

4.4 Detection of Leakage from Natural or Induced Seismicity

The MRV plan states that Aker will monitor the TexNet and USGS earthquake catalogs. If a seismic event of 2.0 magnitude or greater is detected, Aker will investigate the injection volumes and pressures by way of continuous monitoring systems at Aker No. 1, to determine if any significant changes occurred that would indicate potential leakage.

Table 13 of the MRV plan provides a detailed characterization of detecting CO₂ leakage that could be expected from natural or induced seismicity. Thus, the MRV plan provides adequate characterization of Aker's approach to detect potential leakage from natural or induced seismicity as required by 40 CFR 98.448(a)(3).

4.5 Quantifying CO₂ Leakage

The plan states that, given the possibility of uncertainty around the cause of a leakage pathway, Aker believes the most appropriate method to quantify the mass of CO₂ released will be determined on a case-by-case assessment of the circumstances. Any mass of CO₂ detected leaking to the surface will be quantified by using industry-proven engineering methods, including but not limited to engineering analysis on surface and subsurface measurement data, dynamic reservoir modeling, and history-matching of the sequestering reservoir performance. Aker states that in the unlikely event a leak occurs, it will be addressed, quantified, and documented within the appropriate timeline, and records of leakage events will be kept and retained for at least three years.

4.6 Determination of Baselines

Section 6 of the MRV plan identifies the strategies that Aker will use to establish the expected baselines for monitoring CO₂ surface leakage per §98.448(a)(4). The MRV plan states that Aker will use its SCADA system to identify changes from the expected baseline performance that may indicate leakage and quantify the corresponding amounts of CO₂.

Visual Inspections

The MRV plan states that regular inspections are to be conducted by field personnel at Aker Plant, Aker No. 1, and the Aker monitoring wells. If any issues are identified, corrective actions are to be taken in accordance with the H₂S Contingency Plan's safety practices.

CO₂/H₂S Detection

The MRV plan states that because of the presence of H₂S in the acid gas stream, Aker has an H₂S Contingency Plan in place as is required by the TRRC to monitor for releases. The H₂S detection is used as a proxy for identifying the release of CO₂.

In addition to the H₂S monitors, the MRV plan states that Aker will establish and operate a soil gas monitoring program to detect leakage of CO₂ within the MMA. Soil gas samples will be collected from select artificial penetration locations within the MMA and analyzed by a third-party laboratory to establish baseline values. Aker states that soil gas sampling will be performed annually thereafter.

Operational Data

The MRV plan states that Aker will record various pressure measurements related to Aker No. 1 before starting injection under this MRV plan. These measurements could include wellhead, annular, and

bottom hole pressures, for example. Aker states that the recorded pressures will establish baseline measurements for reference to future operating pressures. Any significant deviations over time will be analyzed for any indication of leakage of acid gas and the corresponding component quantities of CO₂.

Continuous Monitoring

The MRV plan states that the total mass of CO₂ emitted by surface leakage and equipment leaks will not be measured directly, as the injection stream for this project is well beyond the Occupational Safety and Health Administration (OSHA) Permissible Exposure Limit (PEL) 8-hour Time Weighted Average (TWA) of 5,000 ppm. Continuous monitoring systems are designed to trigger an alarm if there is a release. The mass of the CO₂ released would be calculated based on the operating conditions, including pressure, flow rate, percentage of CO₂, size of the leak-point opening, and duration.

Groundwater Monitoring

The plant states that Aker will perform baseline and annual groundwater sampling from well No. 3907403 in the northern portion of the stabilized plume. This location is updip of Aker No. 1 and is in an advantageous position to provide an early indication of leakage, should any CO₂ migrate from the Woodbine Formation into shallow surface water zones. A third-party laboratory will be used to analyze the samples and establish the baseline properties of the groundwater. The parameters to be measured will include pH, total dissolved solids, total inorganic and organic carbons, density, temperature, and other standard laboratory measurements. Aker states that any significant variances found in future annual samples will be evaluated for possible leakage of CO₂.

Thus, Aker provides an acceptable approach for detecting and quantifying surface leakage and for establishing the expected baselines for monitoring CO₂ surface leakage in accordance with 40 CFR 98.448(a)(3) and 40 CFR 98.448(a)(4).

5 Considerations Used to Calculate Site-Specific Variables for the Mass Balance Equation

Section 7 of the MRV plan presents the calculation methods that Aker will employ to determine the mass of CO₂ injected, emitted, and sequestered. Site-specific variables for calculating CO₂ emissions from equipment leaks and vented emissions of CO₂ between the injection well and injection volumetric flow meter, in accordance with 40 CFR §98.448(a)(5), are also stated.

5.1 Calculation of Mass of CO₂ Received

Section 7.1 of the MRV plan states that the CO₂ received for Aker No. 1 is to be wholly injected and not combined with any other supply source; the annual mass of CO₂ injected is to be equal to the amount received. Aker states that any additional future streams are to be separately metered before being combined into the calculated injection stream.

Aker provides an acceptable approach for calculating the mass of CO₂ received under subpart RR.

5.2 Calculation of Mass of CO₂ Injected

Section 7.2 of the MRV plan states that in accordance with 40 CFR §98.444(b), because a volumetric flow meter is to be used to measure the flow rate of CO₂ injected, the total annual mass of CO₂ in metric tons is to be calculated by multiplying the volumetric flow at standard conditions by the CO₂ concentration in the flow and the density of CO₂ at standard conditions according to Equation RR-5.

$$CO_{2,u} = \sum_{p=1}^4 Q_{p,u} * D * C_{CO_2,p,u} \quad \text{(Equation RR-5)}$$

where:

CO_{2,u} = Annual CO₂ mass injected (metric tons) as measured by flow meter u.

Q_{p,u} = Quarterly volumetric flow rate measurement for flow meter u in quarter p at standard conditions (standard cubic meters per quarter).

D = Density of CO₂ at standard conditions (metric tons per standard cubic meter): 0.0018682.

C_{CO₂,p,u} = CO₂ concentration measurement in flow for flow meter u in quarter p (vol. percent CO₂, expressed as a decimal fraction).

p = Quarter of the year.

u = Flow meter.

Aker provides an acceptable approach for calculating the mass of CO₂ injected under subpart RR.

5.3 Calculation of Mass of CO₂ Produced

Section 7.3 of the MRV plan states that Aker only processes hydrocarbons and associated CO₂ from deeper formations such as the Sligo and Cotton Valley. There is no production from the Woodbine Formation where the CO₂ is injected. As such, Aker states that no CO₂ will be produced from these injection facilities.

Aker provides an acceptable approach for calculating the mass CO₂ produced under subpart RR.

5.4 Calculation of Mass of CO₂ Emitted by Surface Leakage

Section 7.4 of the MRV plan states that the mass of CO₂ emitted by surface leakage will not be measured directly due to the presence of H₂S in the injection stream and the safety risk that direct leak surveys present for personnel. Because no venting is expected to occur, the calculations would be

based on an unusual blowdown event, with those gas volumes being sent to a flare stack and reported as part of Aker’s reporting requirements. Aker states that any leakage would be detected and managed as an upset event. SCADA continuous monitoring systems would trigger an alarm upon the release of H₂S and CO₂. The mass of the CO₂ released would be calculated based on the operating conditions, including pressure, flow rate, size of the leak-point opening, and duration of the leak.

Additionally, the MRV plan states that in the unlikely event CO₂ is released due to a surface leak, the mass emitted would be calculated for each surface pathway according to methods outlined in the plan and totaled using Equation RR-10 as follows.

$$CO_{2E} = \sum_{x=1}^X CO_{2,x} \quad \text{(Equation RR-10)}$$

where:

CO_{2E} = Total annual CO₂ mass emitted by surface leakage (metric tons) in the reporting year.

CO_{2,x} = Annual CO₂ mass emitted (metric tons) at leakage pathway x in the reporting year.

x = Leakage pathway.

Aker states that methods from Subpart W will be used to calculate CO₂ emissions from equipment located on the surface between the volumetric flow meter and the Aker No. 1 wellhead, and these emissions will be included in the term CO_{2FI} in Equation RR-12.

Aker provides an acceptable approach for calculating the mass of CO₂ emitted by surface leakage under subpart RR.

5.5 Calculation of Mass of CO₂ Sequestered in Subsurface Geologic Formations

Section 7.5 of the MRV plan states that Aker plans to begin injecting in the third quarter of 2025, at which time data collection will begin for calculating sequestered amounts. The mass of CO₂ sequestered will be calculated based on Equation RR-12.

$$CO_2 = CO_{2I} - CO_{2E} - CO_{2FI} \quad \text{(Equation RR-12)}$$

where:

CO₂ = Total annual CO₂ mass sequestered in subsurface geologic formations (metric tons) at the facility in the reporting year.

CO_{2i} = Total annual CO_2 mass injected (metric tons) in the well or group of wells covered by this source category in the reporting year.

CO_{2E} = Total annual CO_2 mass emitted (metric tons) by surface leakage in the reporting year.

CO_{2Fi} = Total annual CO_2 mass emitted (metric tons) from equipment leaks and vented emissions of CO_2 from equipment located on the surface between the flow meter used to measure injection quantity and the injection wellhead, for which a calculation procedure is provided in subpart W of this part.

The MRV plan also states that equations from Subpart W – Petroleum and Natural Gas Systems §98.232 will be used to calculate CO_2 emissions from equipment located on the surface between the flow meter used to measure injection quantities and the injection wellhead.

Aker provides an acceptable approach for calculating the mass of CO_2 sequestered in subsurface geologic formations under subpart RR.

6 Summary of Findings

The subpart RR MRV plan for Aker Plant meets the requirements of 40 CFR 98.448. The regulatory provisions of 40 CFR 98.448(a), which specify the requirements for MRV plans, are summarized below along with a summary of relevant provisions in Aker’s MRV plan.

Subpart RR MRV Plan Requirement	Aker Plant MRV Plan
40 CFR 98.448(a)(1): Delineation of the maximum monitoring area (MMA) and the active monitoring areas (AMA).	Section 3 of the MRV plan delineates the MMA and AMA. The MMA is defined by the stabilized plume after 25 years of density drift plus a one-half mile buffer following the 12-year injection period, which was preceded by 12.667 years of historical injection. The MRV plan defines the AMA as the same area as the MMA.
40 CFR 98.448(a)(2): Identification of potential surface leakage pathways for CO_2 in the MMA and the likelihood, magnitude, and timing, of surface leakage of CO_2 through these pathways.	Section 4 of the MRV plan identifies the following potential surface leakage pathways and evaluates the likelihood, magnitude, and timing of surface leakage through each: surface equipment, existing wells within the MMA, future drilling in the MMA, faults and fractures, confining zones, and natural or induced seismicity.

<p>40 CFR 98.448(a)(3): A strategy for detecting and quantifying any surface leakage of CO₂.</p>	<p>Section 5 of the MRV plan discusses the strategy that Aker will use to detect and quantify any surface leakage of CO₂. The MRV plan states that any mass of CO₂ detected leaking to the surface will be quantified by using industry-proven engineering methods, including but not limited to engineering analysis on surface and subsurface measurement data, dynamic reservoir modeling, and history-matching of the sequestering reservoir performance.</p>
<p>40 CFR 98.448(a)(4): A strategy for establishing the expected baselines for monitoring CO₂ surface leakage.</p>	<p>Section 6 of the MRV plan describes the strategy that Aker will use for establishing the expected baselines for monitoring CO₂ surface leakage. Aker will use its SCADA system to identify changes from the expected baseline performance that may indicate leakage and to quantify the corresponding amounts of CO₂. Additionally, Aker's strategy includes visual inspections, CO₂/H₂S detection, operational data, continuous monitoring, and groundwater monitoring.</p>
<p>40 CFR 98.448(a)(5): A summary of the considerations you intend to use to calculate site-specific variables for the mass balance equation.</p>	<p>Section 7 of the MRV plan summarizes the considerations that Aker intends to use to calculate site-specific variables for the mass balance equation.</p>
<p>40 CFR 98.448(a)(6): For each injection well, report the well identification number used for the UIC permit (or the permit application) and the UIC permit class.</p>	<p>Section 1 of the MRV plan identifies the well identification number (000101798) used for the UIC permit and the UIC class for the Aker No. 1. The well was issued a Class II permit under the TRRC.</p>
<p>40 CFR 98.448(a)(7): Proposed date to begin collecting data for calculating total amount sequestered according to equation RR-11 or RR-12 of this subpart.</p>	<p>Section 8 of the MRV plan states that the MRV plan is to be implemented upon receiving EPA approval. It also states that Aker completed the baseline surveys in July 2025.</p>

Appendix A: Submissions and Responses to Requests for Additional Information



**Subpart RR Monitoring, Reporting, and
Verification Plan
Aker Gas Injection No. 1**

Freestone County, Texas

Prepared for Midcoast G&P (East Texas) L.P.
Houston, Texas

By

Lonquist Sequestration, LLC
Austin, Texas

Revised - August 2025



INTRODUCTION

Midcoast G&P (East Texas) L.P. (Midcoast G&P) operates an acid gas injection well in the Aker (Woodbine H₂S Disposal) Field. The Aker Gas Injection No. 1 (Aker No. 1) API No. 42-161-34475 received its Class II injection permit from the Texas Railroad Commission (TRRC) on June 22, 2010, with a Permit Amendment (Permit No. 13099 Amendment) approved November 15, 2023. The Aker No. 1 has been injecting into the Woodbine Formation since April 2012.

The Aker No. 1 was developed to dispose of oil and gas waste from its Aker Plant in Freestone County, Texas. Located in a rural agricultural area, the plant is approximately 6.2 miles (mi) Northeast of Streetman, TX (Figure 1). The Aker No. 1 is permitted for 9 million standard cubic feet per day (MMscf/d) of treated acid gas (TAG) from the Aker Plant with a maximum allowable surface injection pressure (MASIP) of 1,800 pounds per square inch gauge (psig).

Midcoast G&P is submitting this Monitoring, Reporting, and Verification (MRV) Plan to the Environmental Protection Agency (EPA) for approval under Title 40, U.S. Code of Federal Regulations (40 CFR) **§98.440(a)**, under Subpart RR of the Greenhouse Gas Reporting Program (GHGRP). Midcoast G&P intends to inject into the Aker No. 1 for approximately 12 years at up to a maximum of 9 MMscf/d. The primary source of this injected CO₂ gas is the Aker Plant. Table 1 shows the expected composition of the gas stream to be sequestered.

Table 1 – Expected Gas Composition

Component	Mol Percent
Carbon Dioxide (CO ₂)	98
Hydrogen Sulfide (H ₂ S)	2

Mol – molecular weight of a substance expressed in grams.

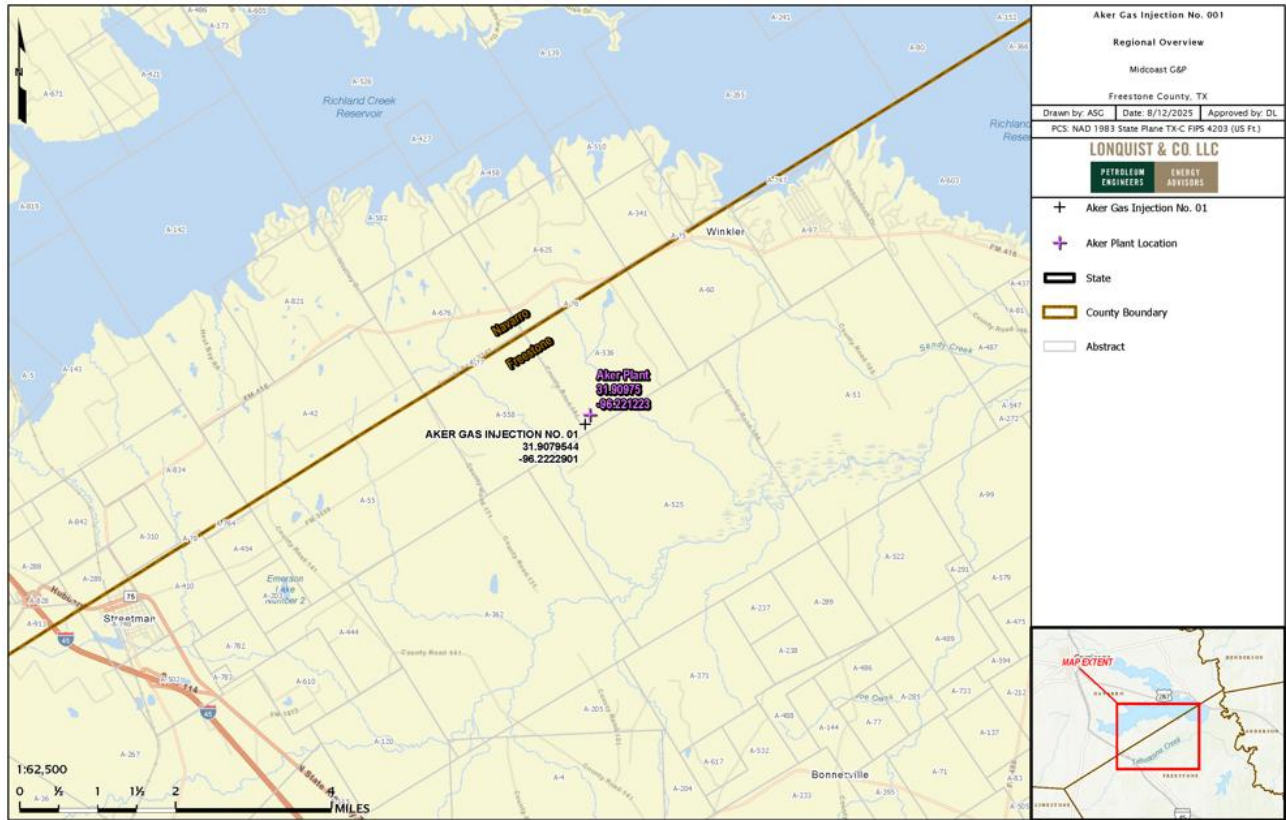

Figure 1 – Location of the Aker Plant and Aker Gas Injection No. 1

ACRONYMS AND ABBREVIATIONS

40 CFR	Title 40, U.S. Code of Federal Regulations
AAPG	American Association of Petroleum Geologists
AMA	active monitoring area
API	American Petroleum Institute
BEG	Bureau of Economic Geology
BHP	bottomhole pressure
BUQW	Base of Usable Quality Water
CFR	U.S. Code of Federal Regulations
CCS	Carbon Capture and Storage
DCSM	Distribution Control System Monitoring
EOS	equation of state
ESD	emergency shutdown (valve)
GAU	Groundwater Advisory Unit
GHG	greenhouse gas (emissions)
GHGRP	Greenhouse Gas Reporting Program
ILD	deep induction log
Ma	million years ago
mD	millidarcy
mg/L	milligrams per liter
MIT	mechanical integrity test
MMA	maximum monitoring area
MMscf/d	million standard cubic feet per day
MMT	million metric tons
MRV	Monitoring, Reporting, and Verification
NACE	National Association of Corrosion Engineers
NAD	North American Datum
NIST	National Institute of Standards and Technology
NSHM	National Seismic Hazard Model

OBG	overburden gradient
ppm	parts per million
psi/ft	pounds per square inch per foot
QA/QC	quality assurance/quality control
RSC	residual sodium carbonate
SAR	sodium-adsorption ratio
SAU	storage assessment unit
SCADA	Supervisory Control and Data Acquisition
SP	spontaneous potential
SWR	Statewide Rule
TAC	Texas Administrative Code
TDS	total dissolved solids
TEC	tubing encapsulated conductor
TRRC	Railroad Commission of Texas
TVD	true vertical depth
TVDSS	true vertical depth subsea
TWDB	Texas Water Development Board
UIC	Underground Injection Control
USDW	Underground Source of Drinking Water
USGS	U.S. Geological Survey
WHP	wellhead pressure
XRD	X-ray Diffraction

TABLE OF CONTENTS

INTRODUCTION	2
ACRONYMS AND ABBREVIATIONS.....	4
SECTION 1 – FACILITY INFORMATION	10
1.1 Reporter Number:	10
1.2 Underground Injection Control Permit Class: Class II	10
1.3 UIC Well Identification Number:	10
1.4 Facility Address	10
SECTION 2 – PROJECT DESCRIPTION	11
2.1 Sources of CO₂	11
2.2 Regional Geology	13
2.3 Structural Setting and Regional Faulting	16
2.4 Site Characterization	18
2.5 Stratigraphy and Lithologic Characteristics	18
2.6 Formation Top Depths	20
2.7 Injection Interval – Woodbine Formation (94 Ma to 96 Ma)	20
2.7.1 Porosity and Permeability Development.....	23
2.7.2 Woodbine Formation Fluid.....	26
2.7.3 Fracture Gradient Discussion.....	28
2.8 Upper Confining Zone – Eagle Ford Shale (89 Ma to 94 Ma)	29
2.9 Lower Confining Zone – Maness Shale (96 Ma to 97 Ma)	33
2.9.1 Injection and Confinement Summary.....	34
2.10 Local Structure	35
2.11 Groundwater Hydrology	37
2.12 Surface Water Hydrology	41
2.12.1 Richland-Chambers Reservoir.....	41
2.12.2 Fairfield Lake.....	41
2.12.3 Trinity River.....	41
2.13 Base of USDW Determination	41
2.14 Reservoir Characterization Modeling	43
2.14.1 Reservoir Modeling – Woodbine.....	43
2.15 Simulation Modeling	46
SECTION 3 – DELINEATION OF MONITORING AREA.....	55
3.1 Maximum Monitoring Area	55
3.2 Active Monitoring Area	55
SECTION 4 – POTENTIAL PATHWAYS FOR LEAKAGE.....	57
4.1 Leakage from Surface Equipment	58
4.2 Leakage from Wells in the MMA	59
4.2.1 Existing Wells Within the MMA.....	59
4.2.2 Future Drilling	62
4.2.3 Freshwater Wells.....	62
4.3 Leakage Through Faults or Fractures	64
4.4 Leakage Through Confining Layers	64
4.5 Leakage from Natural or Induced Seismicity	64
SECTION 5 – MONITORING FOR LEAKAGE.....	67

5.1	Leakage from Surface Equipment	68
5.2	Leakage from Existing Wells Within MMA	71
5.2.1	Aker No. 1 Injection Well	71
5.2.2	Leakage from Oil and Gas Wells in the MMA	72
5.2.3	Leakage Through Groundwater Wells Within MMA	72
5.2.4	Leakage from Future Wells within MMA	75
5.3	Leakage Through Faults, Fractures, or Confining Zones	75
5.4	Leakage Through Natural or Induced Seismicity	75
SECTION 6 – BASELINE DETERMINATIONS		77
6.1	Visual Inspections	77
6.2	CO₂/H₂S Detection	77
6.3	Operational Data	77
6.4	Continuous Monitoring	77
6.5	Groundwater Monitoring	78
SECTION 7 – SITE-SPECIFIC CONSIDERATIONS FOR MASS BALANCE EQUATION		79
7.1	Mass of CO₂ Received	79
7.2	Mass of CO₂ Injected	79
7.3	Mass of CO₂ Produced	80
7.4	Mass of CO₂ Emitted by Surface Leakage and Equipment Leaks	80
7.5	Mass of CO₂ Sequestered	81
7.6	Mass of CO₂ Emitted Due to Leaks Other Than Surface Equipment	81
SECTION 8 – IMPLEMENTATION SCHEDULE FOR MRV PLAN		83
SECTION 9 – QUALITY ASSURANCE		84
9.1	Monitoring Quality Assurance and Quality Control	84
9.2	Missing Data	84
9.3	MRV Plan Revisions	85
SECTION 10 – RECORDS RETENTION		86
REFERENCES		87

Figures

Figure 1 – Location of the Aker Plant and Aker Gas Injection No. 1	3
Figure 2 – Aker Plant and Aker Gas Injection No. 1	12
Figure 3 – Regional East Texas Basin Locator Map showing the location of Aker No. 1 (modified from Roberts-Ashby et al., 2012).	13
Figure 4– Cretaceous stratigraphic column of the East Texas Basin as encountered at the Aker No. 1 a) with the key confining and injection zones annotated (modified from Calavan, 1985), and b) in relation to the deeper geologic formations most targeted for oil and gas production in the surrounding area (modified from USGS).	14
Figure 5 – Formation thickness of the Woodbine in the East Texas Basin (modified from Calavan, 1985). ...	15
Figure 6– Regional type log cross section from west (left) to east (right) across the East Texas Basin (modified from Hentz and Ruppel, 2011). The location of the Aker No. 1 is indicated by the yellow star, near the western-most (far left) well on the cross section.	16
Figure 7 – Major structural features bounding the East Texas Basin with the location of the Aker No. 1 indicated by the yellow star (modified from Swanson et al., 2016).	17

Figure 8– Aker No. 1 (API No. 42-161-34475) open-hole log showing injection and confining zones. The left track has SP (black) and Gamma Ray (green); deep resistivity, AT90, is displayed on a logarithmic scale on the right track.19

Figure 9 – Schematic cross section illustrating regional lithostratigraphic and lithofacies relationships across the Eagle Ford Group (from Hentz et al., 2014).21

Figure 10 – Framework mineralogy of Woodbine sandstones plotted on the Folk (1974) ternary diagram (from Loucks et al., 2015).22

Figure 11– Cross section X-X' through the Aker Monitor Well No. 1, the Aker No. 1, and the Aker Monitor Well No. 2, from left to right, respectively.23

Figure 12 – Reference basemap showing the location of cross section X-X' through the Aker Monitor Well No. 1, the Aker No. 1, and the Aker Monitor Well No. 2, from NW-SE, respectively. The maximum monitoring area (MMA) of the 12-year plume at stabilization plus one half mile buffer (dashed red outline) and all the wells within those limits are displayed on the map.24

Figure 13 – Histogram showing porosity distribution from the three type logs. The average porosity of the injection zone was calculated to be 21.2% +/- 6.7% standard deviation.25

Figure 14 – Porosity versus permeability scatter plot for Woodbine sandstone samples from the East Texas Field. High- and low-end porosity range values as well as average porosity were projected onto the best-fit line (dashed pink) to estimate a permeability range and average (modified from Loucks et al., 2015).26

Figure 15 – Regional Woodbine Salinity Map with the location of the Aker No. 1 indicated by the yellow star, which falls within a salinity range of 60,000 ppm to 70,000 ppm (from Texas Water Development Board, Report 157).28

Figure 16 – Representative thin section photographs of Eagle Ford mudstones: (A) finely laminated, moderately silty, carbonaceous shale; (B) calcareous mudstone with calcite-cemented microfractures; (C) interlaminated very silty shale and argillaceous quartzose siltstone; (D) very silty mottled mudstone with authigenic pyrite nodules (lower left); (E) weakly laminated, carbonaceous and argillaceous, quartzose siltstone; and (F) finely laminated, very fossiliferous (foraminifers and phosphatic bioclasts), carbonaceous shale (from Dawson and Almon, 2010).30

Figure 17 – Representative mineralogical constituents of Eagle Ford shale across different oil and gas regions (Stoneburner, 2014).31

Figure 18 – Isochore map of the Eagle Ford shale, (UCZ).32

Figure 19 – Isochore map of the Maness shale, lower confining zone (LCZ).34

Figure 20 – TVD subsea structure map of the Top of the Woodbine Injection Zone (IZ).36

Figure 21 – Stratigraphic and hydrogeologic units near Freestone County, Texas.37

Figure 22 – Map showing the location of the Aker Gas Injection No. 1 relative to the major aquifers of Texas (modified from Bruun et al., 2016).38

Figure 23 – (a) Structural cross section of the Carrizo-Wilcox Aquifer and overlying strata with the location of the Aker No. 1 projected onto the cross section, and (b) reference map showing the location of the cross section line and Aker No. 1 (modified from Bruun et al., 2016).39

Figure 24 – Total Dissolved Solids (TDS) Map of the Carrizo-Wilcox Aquifer System, showing the location of the Aker No. 1, which is in a predominantly fresh water (< 1,000 mg/L) region.40

Figure 25 – Groundwater and USDW letter issued as part of the Aker No. 1 Class II permit (accessed from Texas Railroad Commission, February 25, 2025).42

Figure 26 – Two-Phase Relative Permeability Curves Used in the tNavigator Model.45

Figure 27 – Areal View of Woodbine Gas Saturation Plume at Shut-in (End of Injection).48

Figure 28 – Areal View of Woodbine Saturation Plume at 25 Years After Shut-in (Stabilized).49

Figure 29 – West-East Cross-Sectional View of Woodbine Gas Saturation Plume at Shut-in (End of Injection).50

Figure 30 – West-East Cross-Sectional View of Woodbine Gas Saturation Plume at 25 Years After Shut-in (Stabilized).	51
Figure 31 – Well Injection Rate and Bottomhole and Surface Pressures Over Time, Woodbine.	53
Figure 32 – Delineation of Maximum Monitoring Area.	56
Figure 33 – Aker No. 1 Process Flow Diagram	59
Figure 34 – Aker Gas Injection No. 1 Wellbore Schematic	60
Figure 35 – All Oil and Gas Wells Within the Maximum Monitoring Area	61
Figure 36 – Groundwater Wells within the MMA.	63
Figure 37 – Hazard map from the 2023 National Seismic Hazard Model Project with the approximate location of Akers No. 1 represented by the red star (modified from USGS, 2023).	64
Figure 38 – BEG TexNet Earthquake Catalog query within a 25 km (15.5 mi) radius of the Akers No. 1 location shown by the red star. The query returned zero (0) earthquakes within the queried radius.	65
Figure 39 – USGS Earthquake Catalog query within a 25 km (15.5 mi) radius of the Akers No. 1 location which returned zero (0) earthquakes within the queried radius.	65
Figure 40 – USGS Earthquake Catalog query within a 100 km (62.1 mi) radius of the Akers No. 1 location to identify the closest recorded seismic event(s). These occurrences are all well outside of the MMA and are only shown for informative purposes.	66
Figure 41 – Aker No. 1 Monitoring and Safety Equipment.	69
Figure 42 – Aker No. 1 Monitoring and Safety Equipment (Part 2).....	70
Figure 43 – Aker No. 1 Wellbore Schematic.....	73
Figure 44 – Oil and Gas Wells Within the MMA.....	74
Figure 45 – Map showing nearest TexNet monitoring station No. 237B, located 40 km east-northeast of Akers No. 1.	76

Tables

Table 1 – Expected Gas Composition	2
Table 2 – Formation Top Depths, as encountered in the Aker AGI No. 1.	20
Table 3 – Framework mineralogy constituents, by volume, of typical Woodbine sandstones.	22
Table 4 – Produced Woodbine Formation Water Characteristics for wells in Freestone, Texas, and surrounding counties (data from USGS National Produced Waters Database, v2.3, accessed Feb. 14, 2025).	27
Table 5 – Fracture Gradient calculation inputs and results for the Aker Gas Injection No. 01 well.	29
Table 6 – Numerical approximations of Eagle Ford shale mineral constituents (values approximated from Stoneburner, 2014).	31
Table 7 – Mineralogy by XRD of Maness Shale samples (Patterson and Denne, 2019).....	33
Table 8 – Modeled Initial Gas Composition.....	44
Table 9 – Key Inputs to Reservoir Model, Woodbine.....	44
Table 10 – tNavigator Model Layer Package Properties.	46
Table 11 – Historical and Future BHP	54
Table 12 – Potential Leakage Pathway Risk Assessment.....	57
Table 13 – Summary of Leakage Monitoring Methods.	67

SECTION 1 – FACILITY INFORMATION

Key information regarding the CO₂ injection facilities is described in this section.

1.1 Reporter Number:

- Greenhouse Gas Facility Name: Aker Plant
- Current Greenhouse Gas Reporting Program ID: 1003129 Subparts C-II, SS, and TT
 - Midcoast G&P will update its reporting information to include Subpart RR with the submittal of this Monitoring, Reporting, and Verification Plan
- Operator: Midcoast G&P (East Texas) L.P.
- Location: North American Datum of 1983 (NAD 83) 31.9079544, -96.2222901

1.2 Underground Injection Control Permit Class: Class II

The TRRC regulates oil and gas activities in Texas and has primacy to implement the Underground Injection Control (UIC) Class II program. On June 22, 2010, the TRRC issued a Class II oil and gas waste permit for Aker No. 1 in accordance with Statewide Rules 9 and 36, with a Permit Amendment (Permit No. 13099 Amendment) approved on November 15, 2023.

1.3 UIC Well Identification Number:

- 000101798

1.4 Facility Address

261 FCR 181
STREETMAN, TX, 75859

SECTION 2 – PROJECT DESCRIPTION

This section outlines the geologic context, planned injection volumes, and reservoir modeling conducted by Lonquist Sequestration, LLC, for the Aker Gas Injection No. 1 (Aker No. 1). Midcoast G&P injects an acid gas mixture of CO₂ and H₂S into the Woodbine Formation by way of Aker No. 1 for sequestration. The Aker Plant and Aker No. 1 are designed and operated to prevent leaks from mechanical systems and the injection zone, safeguarding the Underground Source of Drinking Water USDW and preventing surface releases. The Woodbine Formation, the designated injection zone, is protected by multiple overlying formations that ensure subsurface containment. The Eagle Ford shale serves as the Upper Confining Zone (UCZ), with the Maness Shale providing the Lower Confining Zone (LCZ).

2.1 Sources of CO₂

The acid gas stream injected into the Aker No. 1 well is separated from the production gas stream at the amine unit at the Aker Plant in Freestone County, Texas. From the amine unit, the acid gas stream is measured, sampled, and pumped to the nearby Aker No. 1 well and injected into the disposal formation. The acid gas stream from the Aker Plant is the only source of CO₂ to be injected into the Aker No. 1 well. An image of the Aker Plant and surrounding facilities is presented in Figure 2.



Figure 2 – Aker Plant and Aker Gas Injection No. 1.

2.2 Regional Geology

The Aker No. 1 site lies in Freestone County, Texas, within the East Texas basin, as depicted in Figure 3. This basin, one of three Mesozoic basins along the northern Gulf Coastal Plain, formed as complex rift systems on thinned continental crust during the Triassic Period (Foote et al., 1988). Initial rifting and crustal thinning, combined with later sediment loading, led to more than 23,000 feet (ft) of subsidence in the center of the basin (Jackson and Seni, 1984). The basin covers more than 68,000 square miles (Dolton et al., 1981) and is a major oil and gas producing basin from Cretaceous aged strata.

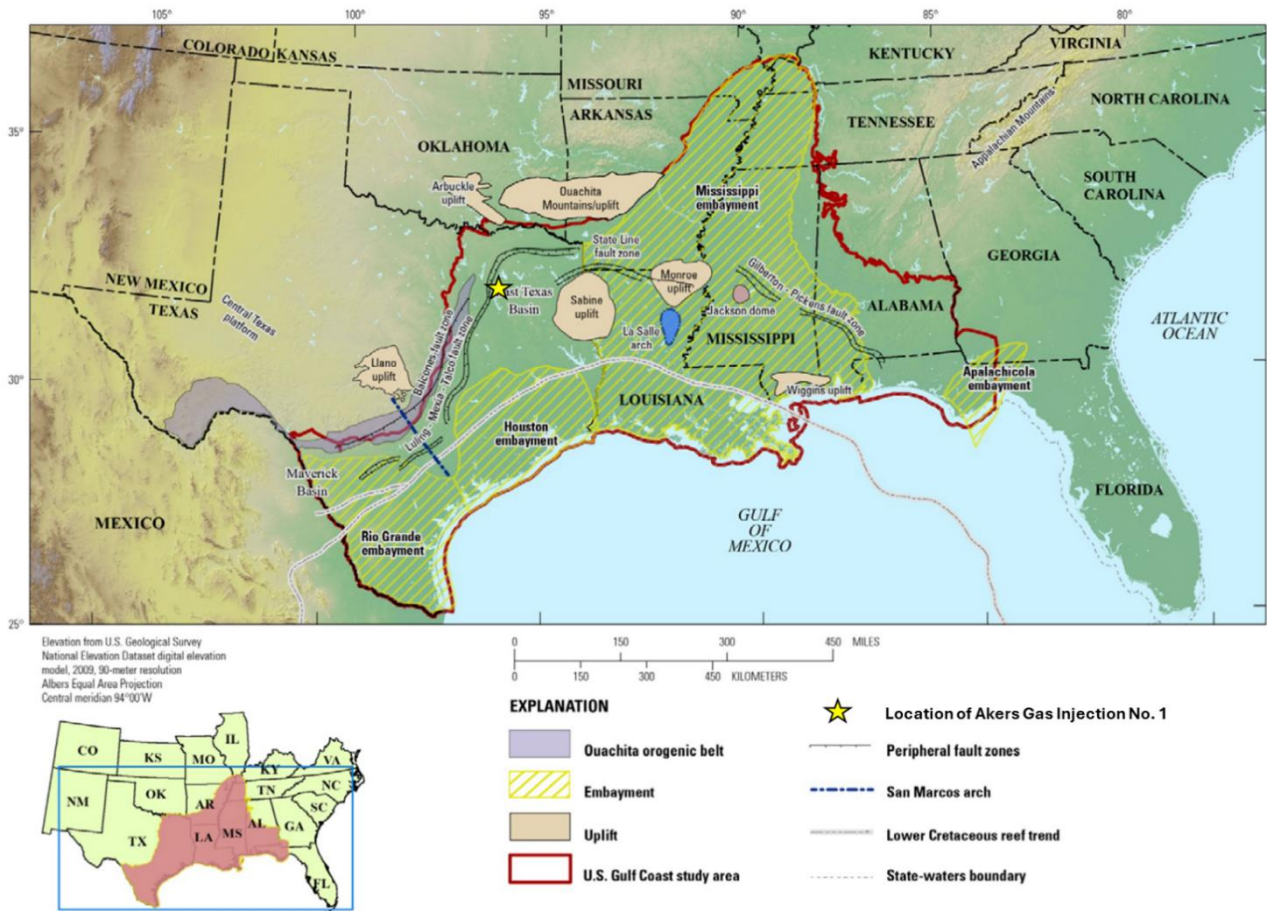

Figure 3 – Regional East Texas Basin Locator Map showing the location of Aker No. 1 (modified from Roberts-Ashby et al., 2012).

The Woodbine Formation, the primary injection zone, was laid down on the submerged Upper Cretaceous shelf before the Sabine Uplift's emergence. It rests atop the Buda Limestone and is erosionally overlain by the Eagle Ford Shale and Austin Chalk Formations, as illustrated in the stratigraphic columns in Figure 4. Figure 4a highlights key injection and confining zones of the Aker No. 1 site and Figure 4b depicts their position relative to the deeper oil and gas producing formations in the surrounding area.

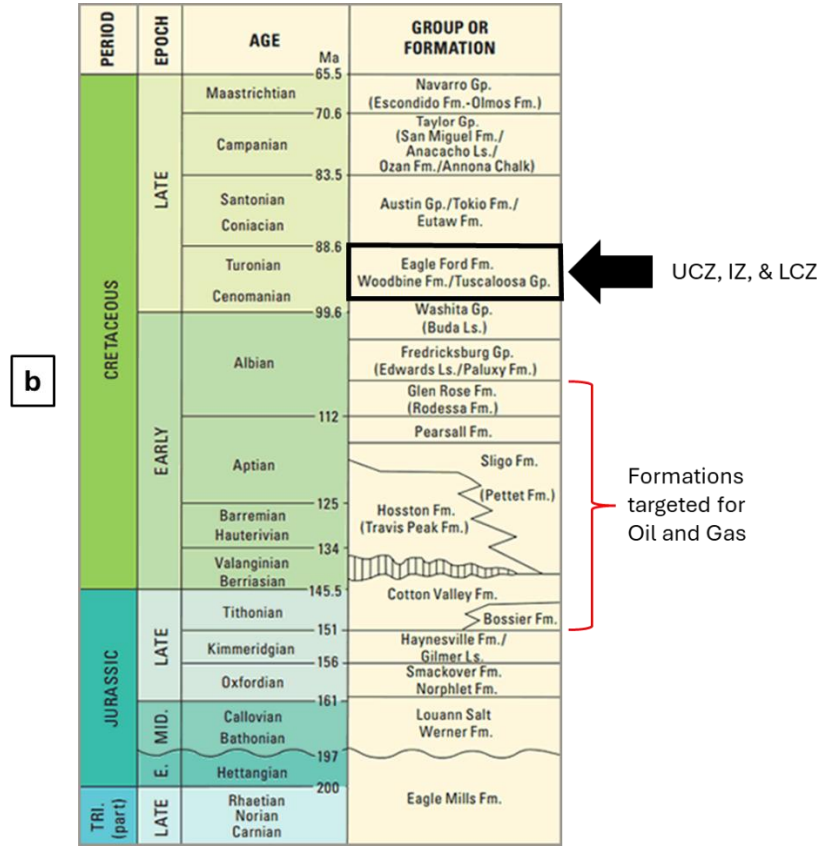
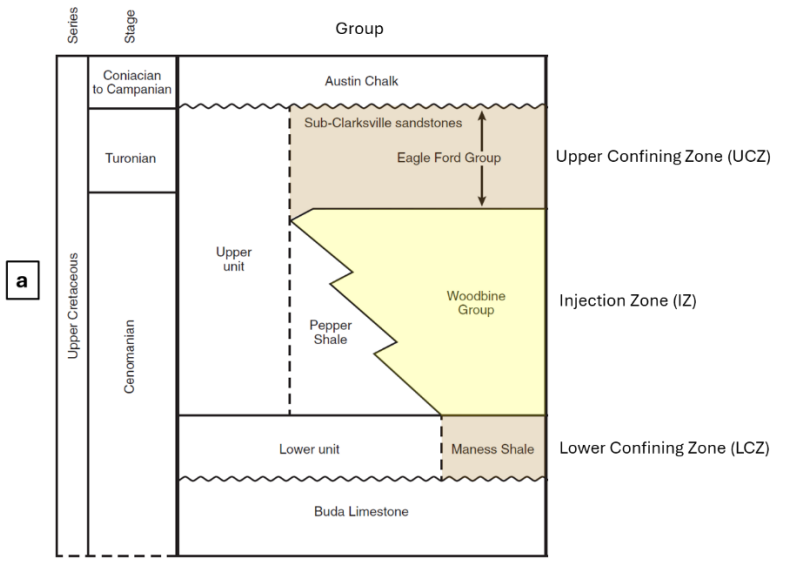

Figure 4– Cretaceous stratigraphic column of the East Texas Basin as encountered at the Aker No. 1 **a)** with the key confining and injection zones annotated (modified from Calavan, 1985), and **b)** in relation to the deeper geologic formations most targeted for oil and gas production in the surrounding area (modified from USGS).

The Woodbine is an unconformity-bounded unit recording numerous high-frequency sequences, composed predominantly of siliciclastic sediment delivered by the Woodbine delta system. Erosion of the Sabine uplift is commonly interpreted as the dominant sediment source for the Woodbine and Eagle Ford Groups in the East Texas Basin (Ewing, 2009). The Woodbine and Eagle Ford successions are unconformably bound by the Buda Limestone below and the Austin Chalk above, with both erosional surfaces representing significant hiatuses in sediment deposition (Meyer et al., 2021).

There is considerable variation in thickness and facies across the greater East Texas Basin, as shown in the regional isopach map in Figure 5 and regional cross section in Figure 6. While the axis of the Woodbine delta system is largely responsible for variations in thickness east-to-west across the basin, variations from north-to-south are controlled by other depositional factors. The typically much thicker northern parts of the basin are dominated by sandstone-prone shelf-margin-to-fluvial deposits (Ambrose et al., 2009). Whereas in the southern extension of the basin, referred to as the Brazos Basin, correlative Woodbine strata is commonly found on the order of 100 ft thick and is dominated by argillaceous, basinal mudstone. This north-to-south thickness variation and shelf, slope, and basin profile create relict physiography onto which depositional sequences in the Eagle Ford Group sequentially lap.

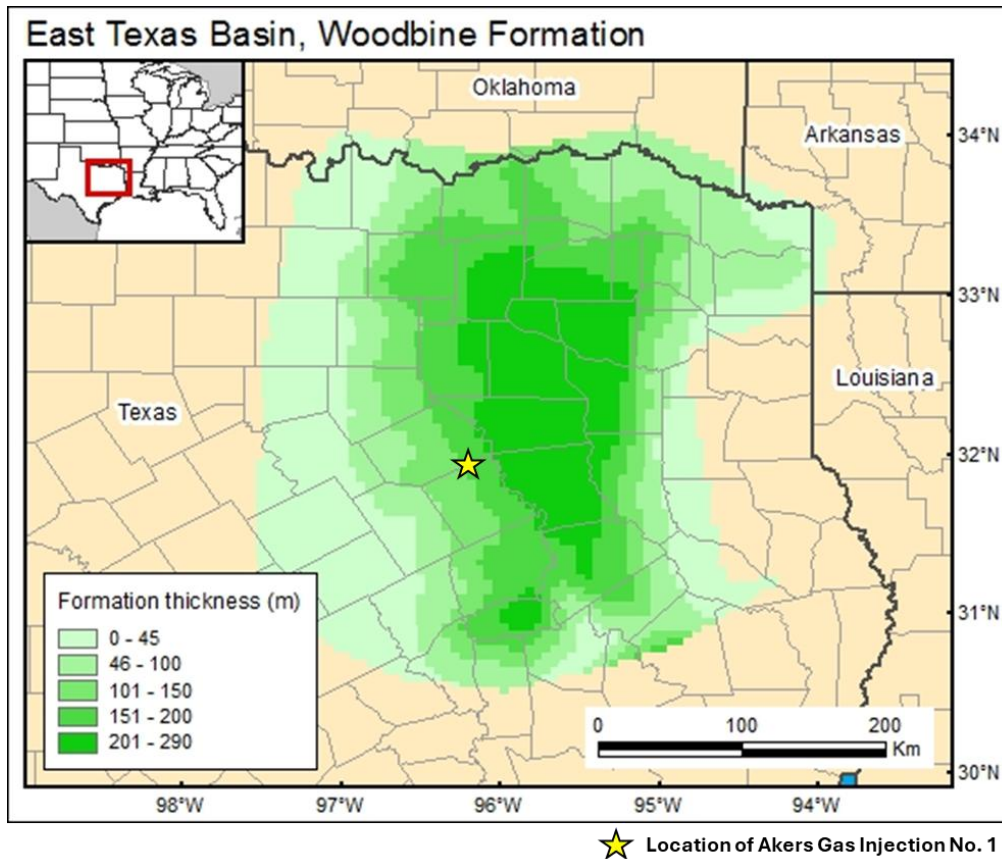

Figure 5 – Formation thickness of the Woodbine in the East Texas Basin (modified from Calavan, 1985).

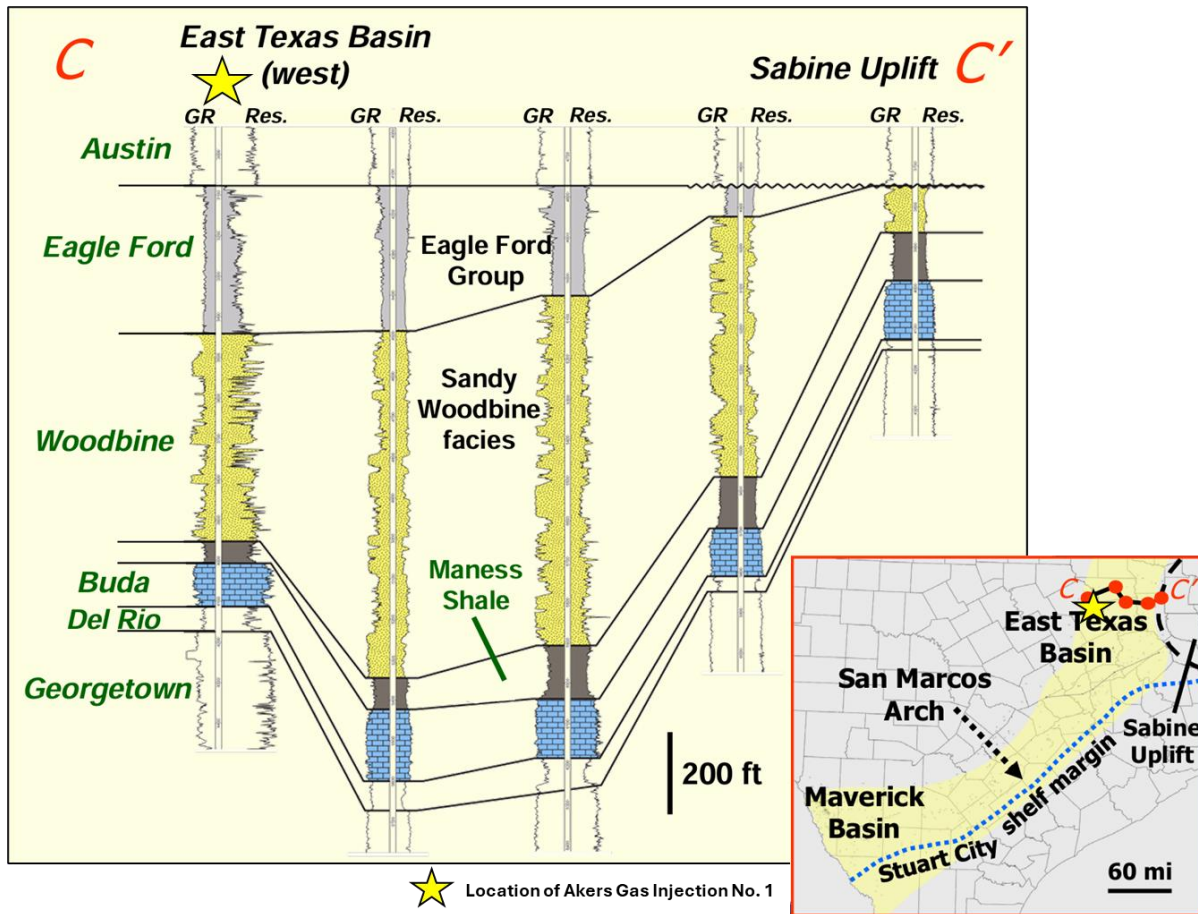

Figure 6– Regional type log cross section from west (left) to east (right) across the East Texas Basin (modified from Hentz and Ruppel, 2011). The location of the Aker No. 1 is indicated by the yellow star, near the western-most (far left) well on the cross section.

2.3 Structural Setting and Regional Faulting

The Gulf of Mexico basin was formed by crustal extension and seafloor spreading associated with the Mesozoic breakup of Pangea. Rifting of northwest to southeast (NW-SE) trending transfer faults during the Middle Jurassic lasted approximately 25 million years and resulted in a variable thickness of transcontinental crust underlying the region. By the Lower Cretaceous time, the general outline and morphology of the Gulf were similar to that of the present day (Galloway, 2008; Yurewicz et al., 1993).

Lower Cretaceous tectonic activity was limited to regional subsidence associated with areas of variable crustal thickness and local structuring caused by movement of the Louann Salt (Yurewicz et al., 1993). The combination of these processes resulted in the structural development of regional arches, grabens, uplifts, embayments, salt domes, and salt basins around the northern edge of the basin (Dennen and Hackley, 2012; Galloway, 2008). The locations of these structural features are displayed in Figure 7 relative to the Aker No. 1 location.

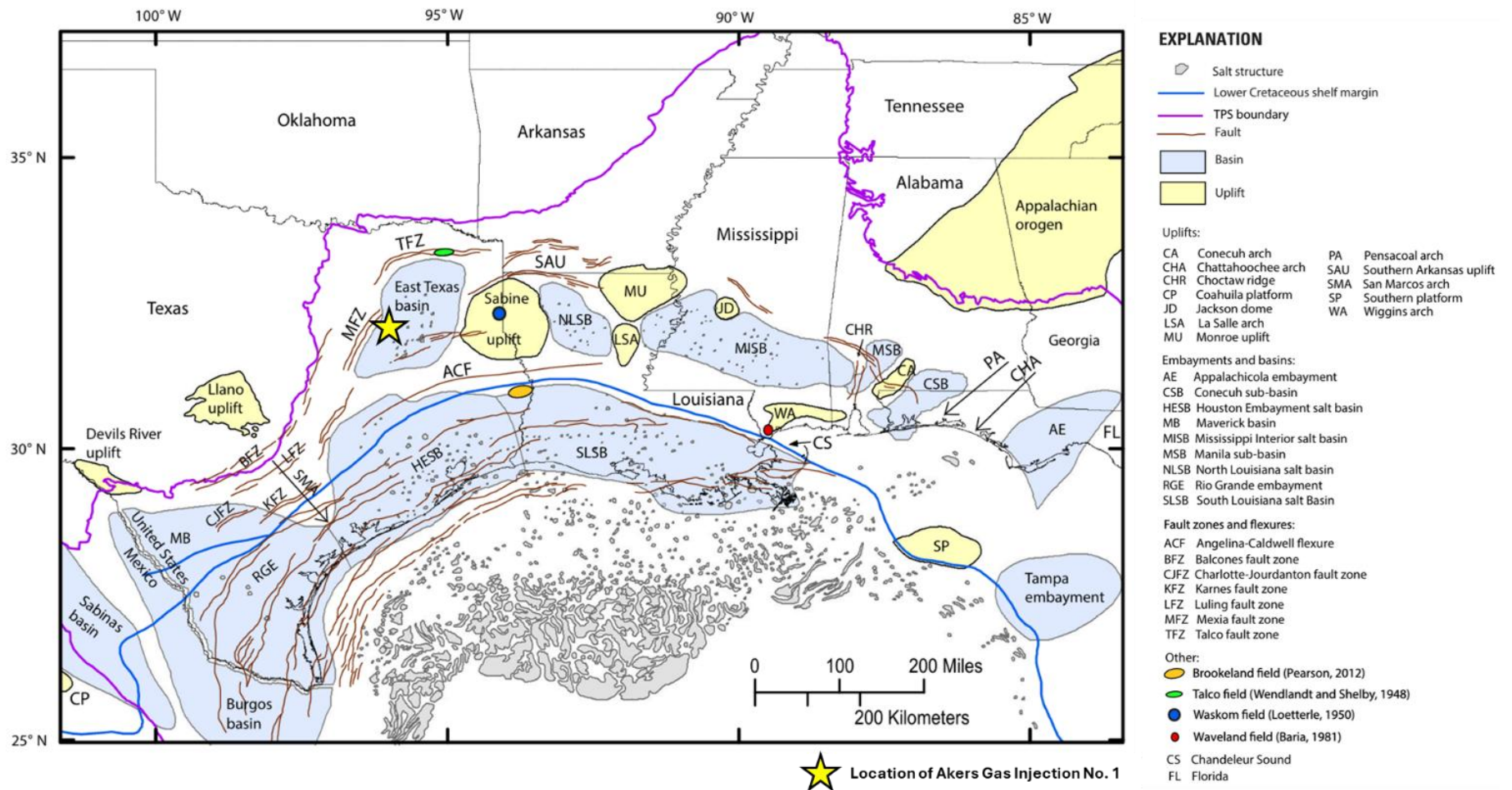

Figure 7 – Major structural features bounding the East Texas Basin with the location of the Aker No. 1 indicated by the yellow star (modified from Swanson et al., 2016).

The Sabine Arch forms the eastern boundary while a series of both normal and thrust fault systems—the Ouachita, Balcones, Luling, and Mexia-Talco Fault Zones—provide the western and northern boundaries of the East Texas basin. The mobilization of the Louann Salt is believed to be responsible for the initial movement of these major fault systems. The southern boundary is marked by the Angelina Caldwell Flexure.

2.4 Site Characterization

The Aker No. 1 is in Abstract A-536 of the J. Richards Survey in Freestone County, Texas. Midcoast G&P has a lease agreement with the landowners for the 5.17-acre tract where the Aker No. 1 is located. The following section discusses the geologic character of this site.

2.5 Stratigraphy and Lithologic Characteristics

Figure 8 shows an open-hole log from the Aker No. 1 (API No. 42-161-34475), with the injection and confining zones annotated on the log. The well was originally completed on June 27, 2011, through the perforations from 3,905 ft to 3,948 ft, from 4,056 ft to 4,061 ft, from 4,066 ft to 4,080 ft, and from 4,144 ft to 4,184 ft, which are plotted on the log image in Figure 8. These perforations are still active today for acid gas injection.

★
AKER GAS INJECTION 1
42161344750000

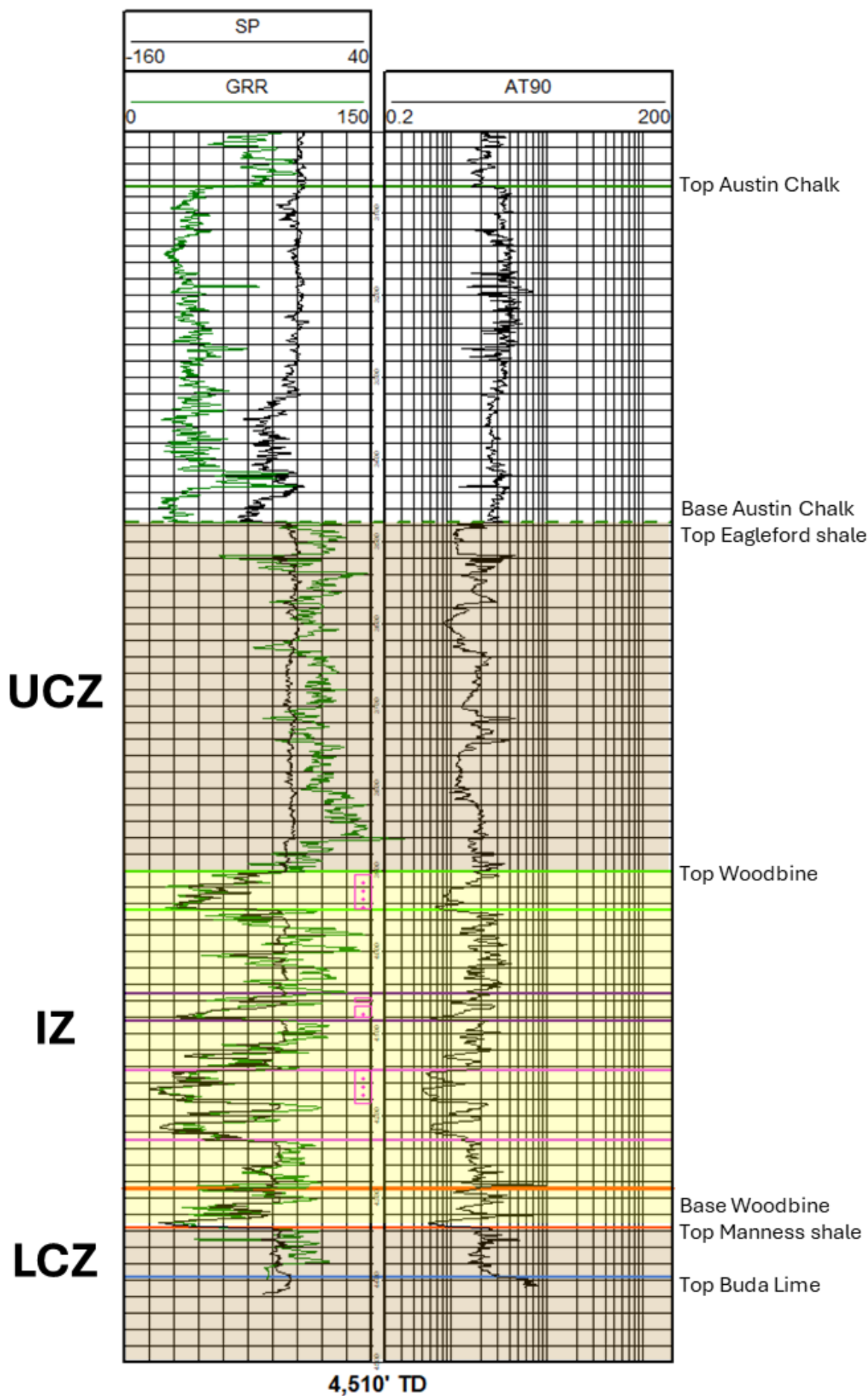

Figure 8– Aker No. 1 (API No. 42-161-34475) open-hole log showing injection and confining zones. The left track has SP (black) and Gamma Ray (green); deep resistivity, AT90, is displayed on a logarithmic scale on the right track.

2.6 Formation Top Depths

Key regional formation tops were picked and correlated across well logs within 5 mi of the Aker No. 1 AGI site. Structure maps were produced on these horizons to gain an understanding of bed dip and structural features within the Aker No. 1 AGI area. Table 2 lists the depths of key formation tops as encountered in the Aker No. 1 AGI well, along with relevant comments related to the ongoing acid gas injection operations.

Table 2 – Formation Top Depths, as encountered in the Aker AGI No. 1.

Formation Top	TVD (true vertical depth)	Notable Information
Base Wilcox	425'	-Base of usable-quality groundwater/freshwater aquifers
Top Pecan Gap	2,155'	
Top Austin Chalk	3,068'	
Base USDW	3,150'	-Potential USDW to protect (GAU letter)
Base Austin Chalk/Top Eagle Ford Shale	3,477'	-Top of UCZ
Base Eagle Ford Shale/Top Woodbine "A"	3,903'	-Base of UCZ/Top of IZ
Base Woodbine "A"	3,949'	
Top Woodbine "B"	4,051'	
Base Woodbine "B"	4,084'	
Top Woodbine "C"	4,144'	
Base Woodbine "C"	4,230'	-Base of IZ
Top Woodbine "D"	4,288'	
Base Woodbine "D"/Top Maness Shale	4,337'	-Top of LCZ
Top Buda Lime	4,397'	-Top of secondary LCZ

GAU – Groundwater Advisory Unit

IZ – injection Zone

LCZ – Lower Confining Zone

UCZ – Upper Confining Zone

USDW – Underground Source of Drinking Water

2.7 Injection Interval – Woodbine Formation (94 Ma to 96 Ma)

The proposed injection interval of the Aker No. 1 is the siliciclastic Upper Cretaceous, Woodbine Formation. The Woodbine is a fluvial and deltaic formation that prograded from the north into the East Texas Basin (Hovorka, 1999). The Aker No. 1 is located within what is referred to as the "Eaglebine" trend, which comprises of the Cenomanian Maness Shale (LCZ), Woodbine Group (IZ), and upper Cenomanian and Turonian Eagle Ford Group (UCZ), as shown in Figure 9. Aerially, the play is defined primarily by the subsurface distribution of Woodbine Group and Eagle Ford sandstones and equivalent mudrock facies; therefore, the name Eaglebine (Hentz et al., 2014).

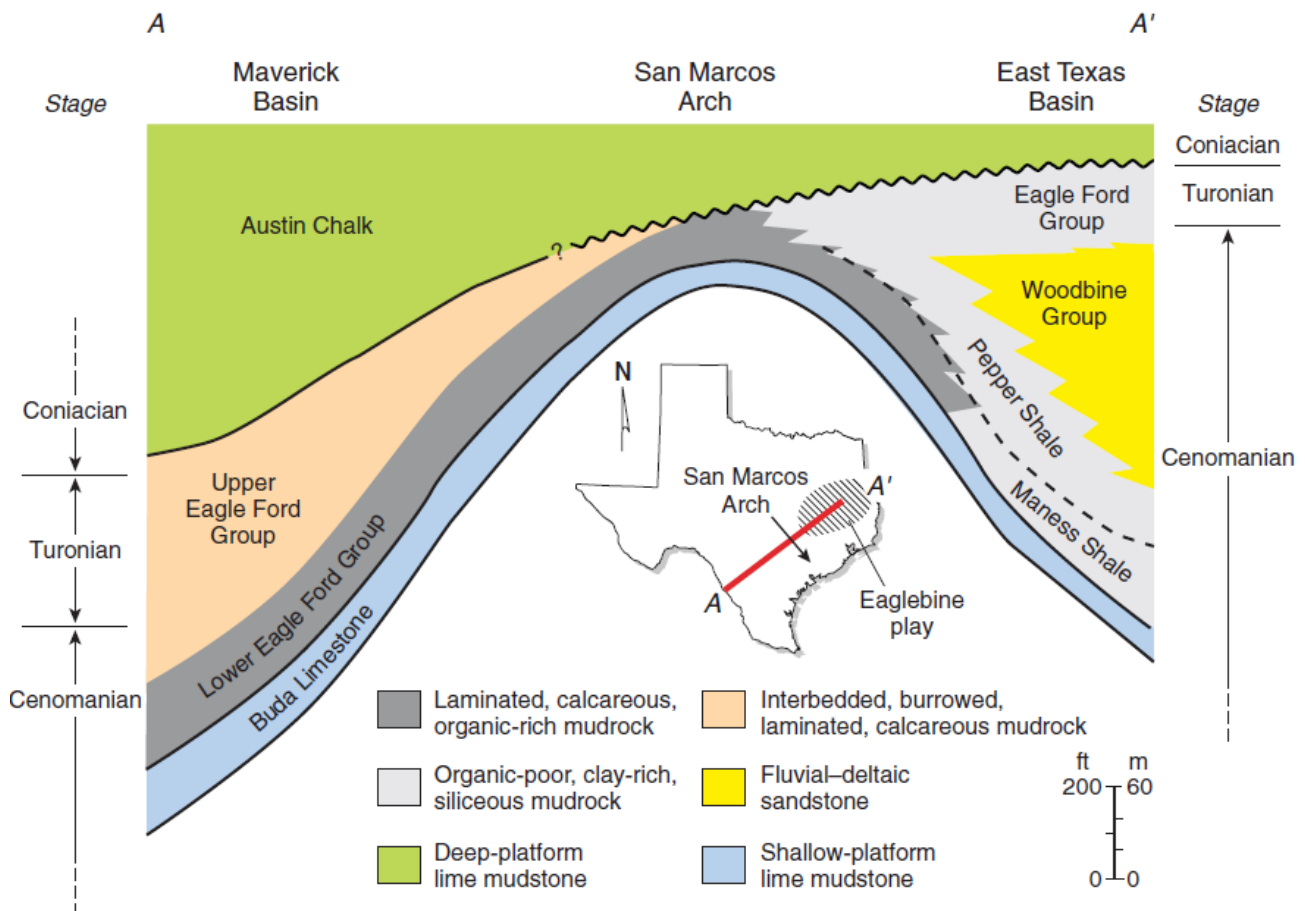

Figure 9 – Schematic cross section illustrating regional lithostratigraphic and lithofacies relationships across the Eagle Ford Group (from Hentz et al., 2014).

The Woodbine Formation is composed of arkosic quartzarenites having calcite, dolomite, ankerite, quartz, kaolinite, illite, and smectite as the dominant diagenetic phases, and contains sodium chloride (NaCl) brines (Hovorka, 1999). Woodbine sandstones commonly have more than 95% framework quartz with a few samples in the sublitharenite field using the classification of Folk (1974), as shown in Figure 10. Mineralogy constituents on average point-count data for Woodbine sandstones are presented in Table 3.

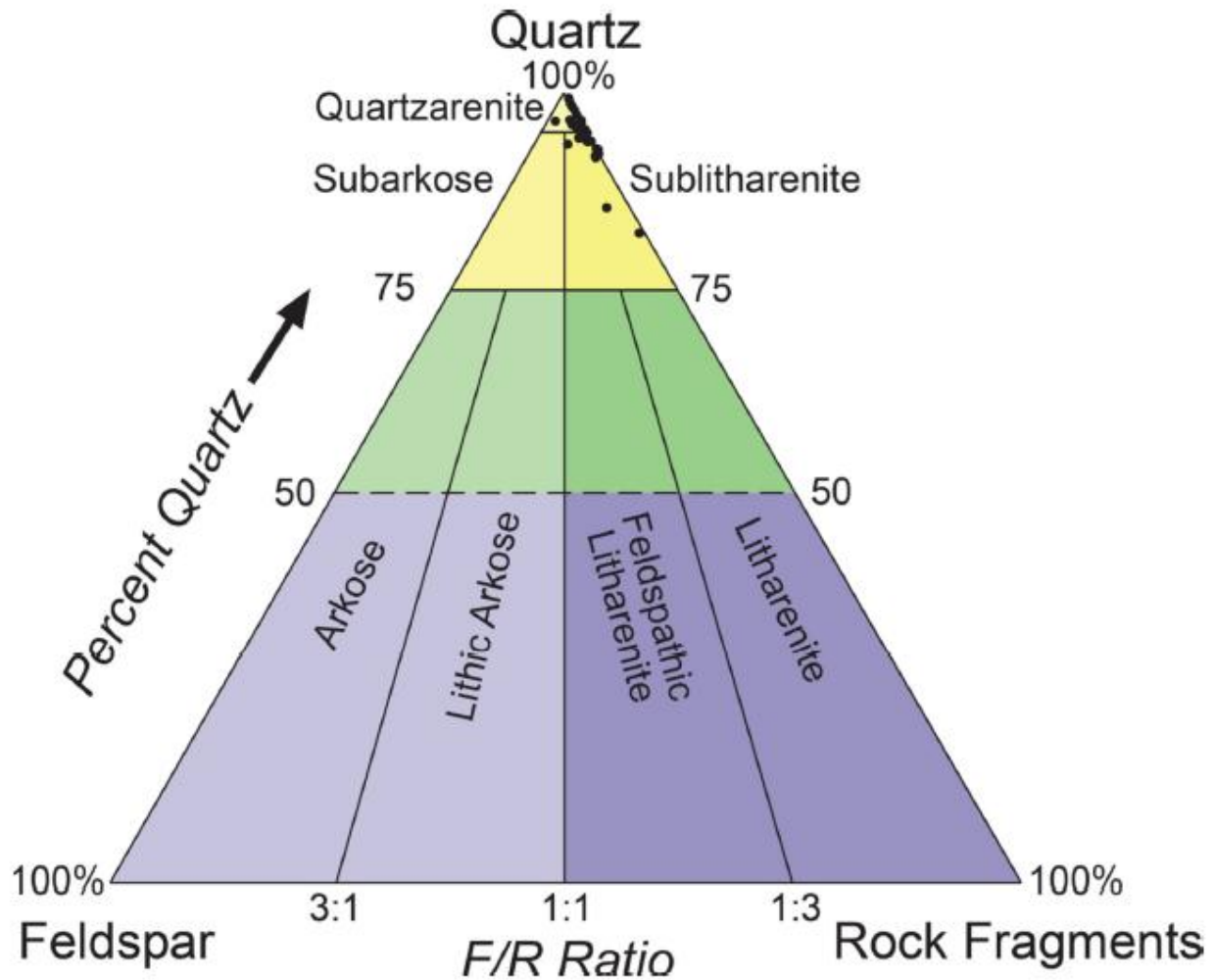

Figure 10 – Framework mineralogy of Woodbine sandstones plotted on the Folk (1974) ternary diagram (from Loucks et al., 2015).

Table 3 – Framework mineralogy constituents, by volume, of typical Woodbine sandstones.

Woodbine Sandstone (IZ)	
Mineral Constituent	% Framework (by volume)
Quartz	95%
K-feldspar	2%
Plagioclase feldspar	1%
Micas	1%
Rock fragments (volcanic/chert)	1%

The following subsections outline the porosity and permeability distributions, formation water geochemistry, and fracture gradient discussion of the Woodbine injection interval found between depths of 3,903 ft and 4,337 ft true vertical depth (TVD) in the Aker No. 1.

2.7.1 Porosity and Permeability Development

Three modern-type logs were selected to represent the rock properties of the injection and confining intervals. These logs include the Aker No. 1 and the two monitoring wells, which are shown in the NW-SE cross section in Figure 11. A larger image of Figure 11 is provided in Appendix A. A reference map showing the location of the cross section is shown in Figure 12. The Aker Monitoring Well No. 1 is located 4,150 ft northwest of the AGI well, and the Aker Monitoring Well No. 2 is located 4,285 ft southeast of the AGI well. These three wells were all drilled in April 2011 or May 2011, and open-hole triple combo logs were run by Schlumberger, thus providing consistent data points proximal to the actual Aker No. 1 location.

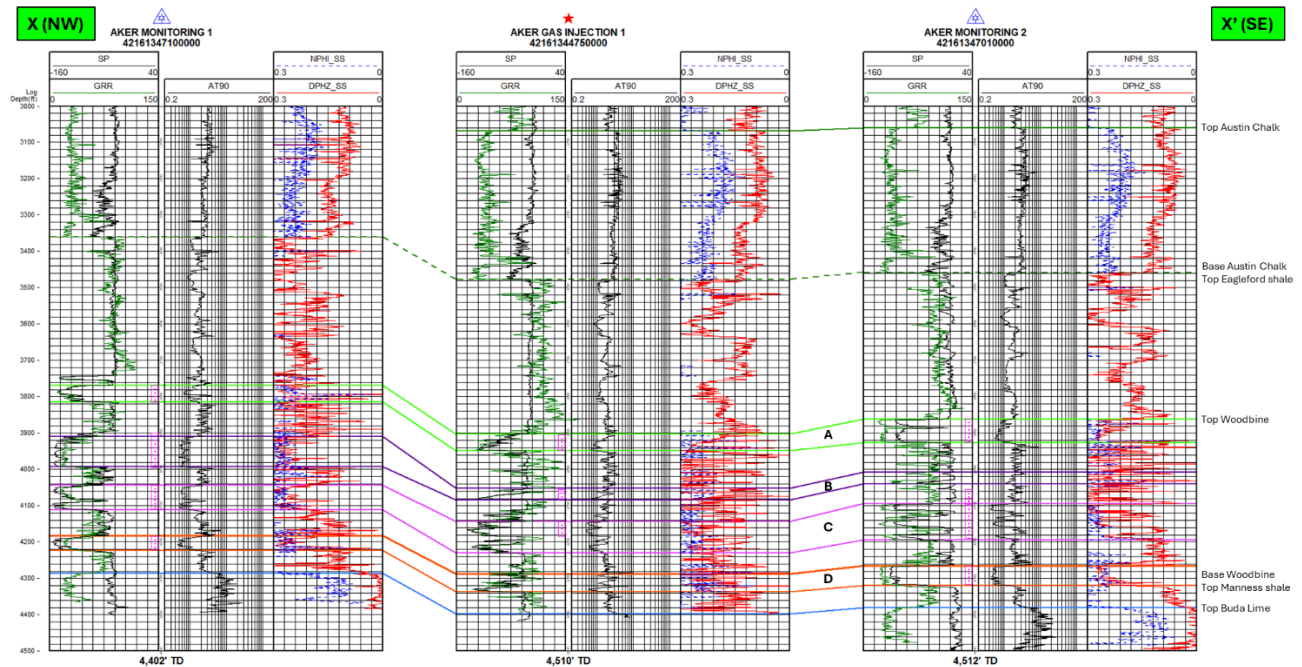

Figure 11– Cross section X-X' through the Aker Monitor Well No. 1, the Aker No. 1, and the Aker Monitor Well No. 2, from left to right, respectively.

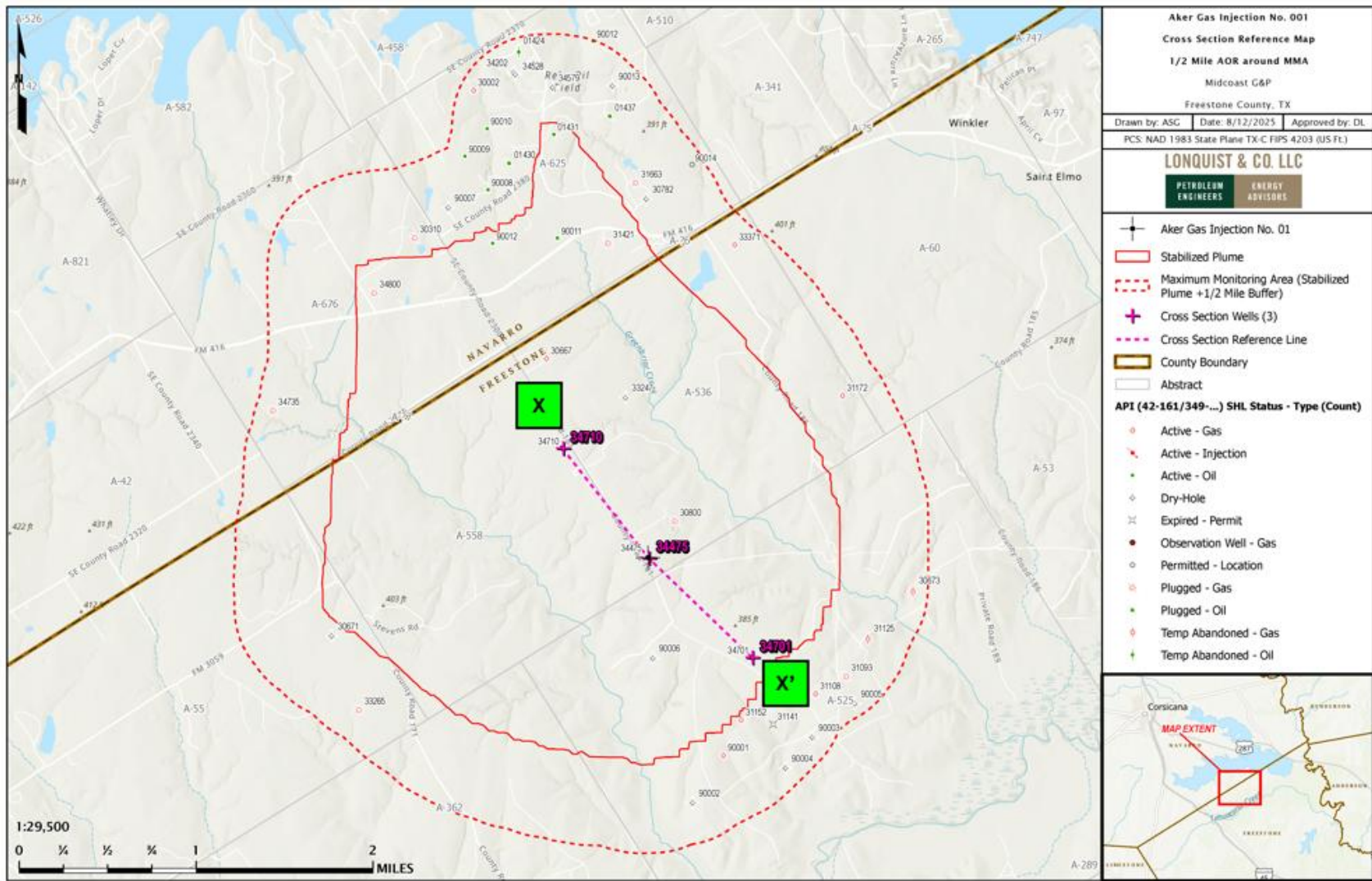

Figure 12 – Reference basemap showing the location of cross section X-X' through the Aker Monitor Well No. 1, the Aker No. 1, and the Aker Monitor Well No. 2, from NW-SE, respectively. The maximum monitoring area (MMA) of the 12-year plume at stabilization plus one half mile buffer (dashed red outline) and all the wells within those limits are displayed on the map.

Average porosity values of the different zones were calculated directly from the density porosity measurements in the three type logs. A histogram showing the distribution of porosity values within the injection zone from the three type logs is presented in Figure 13.

Porosities ranged from 14.5% to 27.9% across the three type logs, with an average porosity of 21.2% +/- 6.7% standard deviation. These values align with Woodbine porosity ranges represented in published research papers.

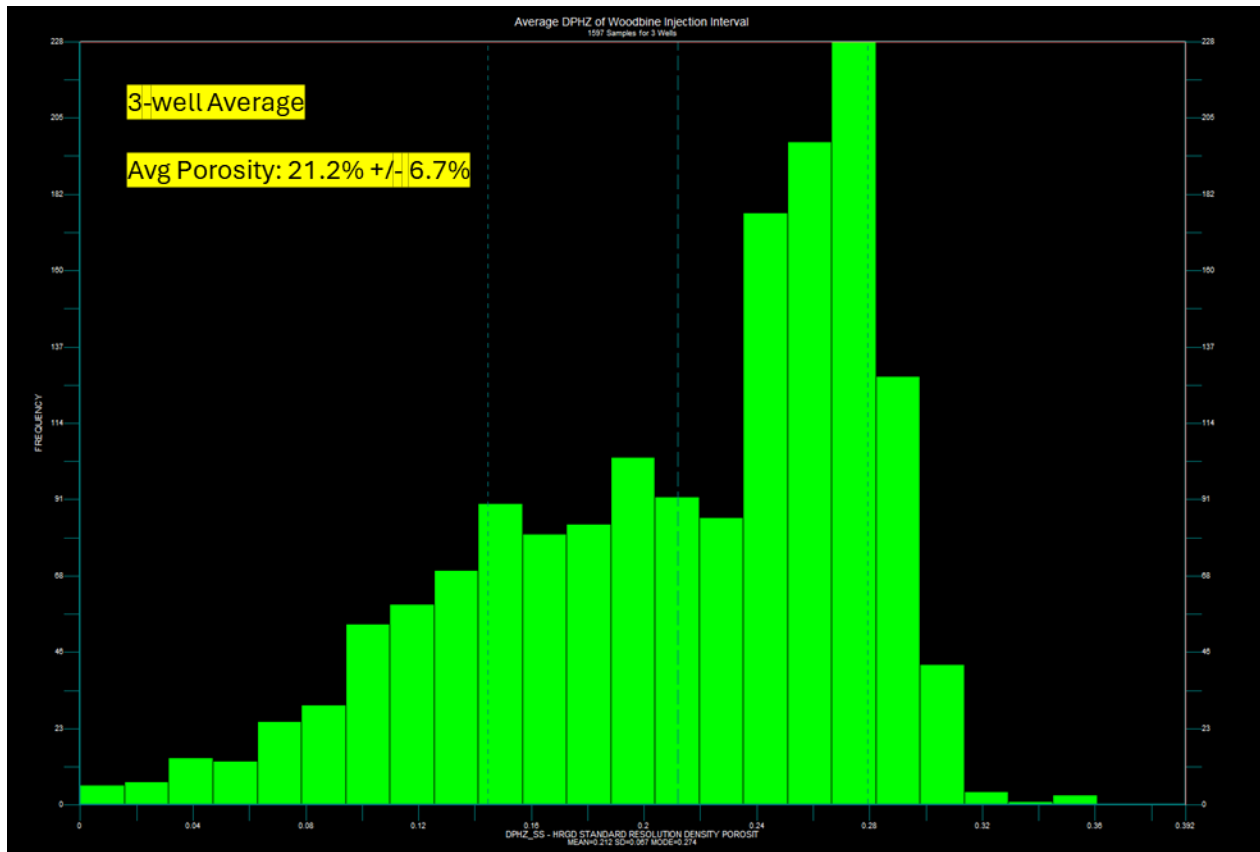

Figure 13 – Histogram showing porosity distribution from the three type logs. The average porosity of the injection zone was calculated to be 21.2% +/- 6.7% standard deviation.

Because of a lack of publicly available core data in the Woodbine formation proximal to the Maximum Monitoring Area (MMA), porosity-permeability relationships from published literature were reviewed for potential application. A crossplot by Loucks et al. (2015), shown in Figure 14, using core samples in the East Texas field, was selected to transform porosity to permeability.

The average porosity value (21.2%) was projected onto the best-fit line (dashed pink line in Figure 14) of the Loucks et al. (2015) crossplot to estimate an average permeability of 80 millidarcies (mD). Standard deviation lines (dashed gray) were drawn to bracket the best-fit line to estimate a permeability range of 2.5 mD to 1,600 mD. This permeability range aligns with the range generated

by projecting the minimum and maximum porosity range values (14.5% and 27.9%, respectively) onto the best-fit line, providing added confidence.

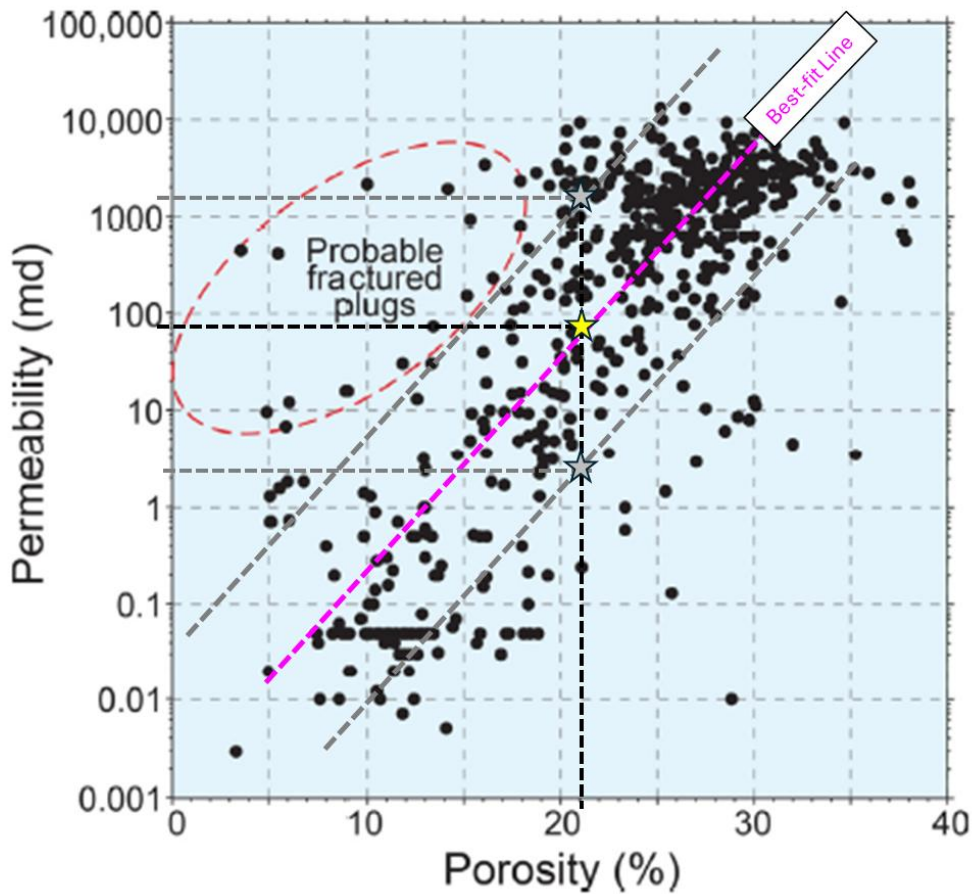

Figure 14 – Porosity versus permeability scatter plot for Woodbine sandstone samples from the East Texas Field. High- and low-end porosity range values as well as average porosity were projected onto the best-fit line (dashed pink) to estimate a permeability range and average (modified from Loucks et al., 2015).

2.7.2 Woodbine Formation Fluid

A review of formation water from the USGS National Produced Water Geochemical Database, v. 2.3 identified 18 samples with analyses collected from the Woodbine Formation in wells in Freestone County and neighboring counties (i.e., Navarro, Anderson, Henderson, and Limestone). A summary of formation fluid characteristics is presented in Table 4.

Table 4 – Produced Woodbine Formation Water Characteristics for wells in Freestone, Texas, and surrounding counties (data from USGS National Produced Waters Database, v2.3, accessed Feb. 14, 2025).

IDUSGS	API	DEPTH	PH	TDS	HCO3	Ca	Cl	Mg	Na	SO4
86291	42-001-01430	5831		85645	205	2950	51991	540	29895	265
86355	42-293-00355	2952		23644	488	464	14000	137	8481	24
86405	42-001-02207	4665	6.7	100000	281	3400	61200	850	34300	122
86410	42-001-00425		7.8		528	168	4020	19	2610	67
86429	42-001-02207		7.0	100300	186	3540	61200	523	34800	93
86430	42-001-01788	5811.5	6.3	120435	288	3920	73200	494	42268	265
86431	42-001-01788	5811.5	6.3	98079	300	3600	59640	481	33846	212
89619		4031		71138	421.30	1976.	42940.75	359.46	25033.58	204.36
90061		3020		28162	342	528	16900	171	10156	
92750		3077	7.8	13838	838.30	64.64	7696.20	34.34	5179.28	25.25
98232	42-349-00068	3300	7.90	20026.50	1232.01	95.32	11103.30	42.59	7501.57	51.71
99778			7.00	81593	305	2500	49620	375	28710	47
99779			7.02	63650	215	1930	38740	330	22330	37
99780			7.03	88835	350	2830	54050	485	31000	70
99781			7.11	79959	325	2400	48610	430	28100	60
99782			7.07	84504	360	2600	51360	410	29690	54
099783			7.85		225	185	3875	31	2320	15
100768		3583	7.10	29577		1445	14000	12	9380	
AVERAGE:			7.14	68,085	382	1,922	36,897	318	21,422	101

IDUSGS – United States Geological Society Identification

API – American Petroleum Institute

PH – potential of hydrogen

TDS – total dissolved solids

HCO3 – bicarbonate

Ca – calcium

Cl - chlorine

Mg - magnesium

Na - sodium

SO₄ - sulfate

The sampled locations contain a wide range of depths and ion concentrations with an average total dissolved solids (TDS) concentration of 68,085 parts per million (ppm). Salinity was calculated from calculating apparent water resistivity (R_{wa}) in the three type wells in conjunction with bottomhole temperature to derive a salinity range of 58,000 ppm to 75,000 ppm, with an average of 69,000 ppm. Additionally, the Texas Water Development Board (TWDB) Regional Woodbine Salinity Map shown in Figure 15 suggests an estimated salinity of 60,000 ppm to 70,000 ppm at the Aker No. 1 location. The three different methods of calculating salinity resulted in very consistent values providing confidence in their accuracy. A best-fit salinity of 69,000 ppm was selected for modeling purposes.

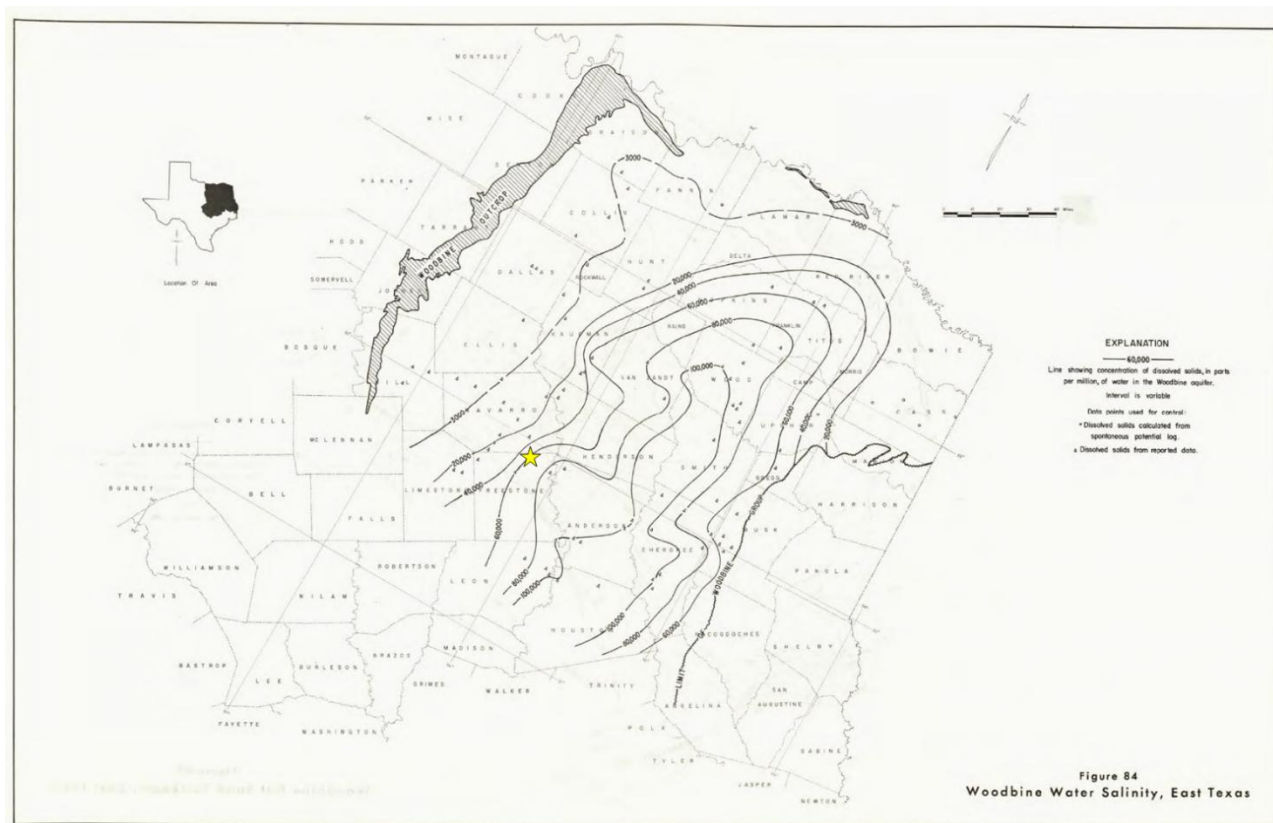

Figure 15 – Regional Woodbine Salinity Map with the location of the Aker No. 1 indicated by the yellow star, which falls within a salinity range of 60,000 ppm to 70,000 ppm (from Texas Water Development Board, Report 157).

The primary constituent of the Woodbine Formation fluid is chloride (Cl), with an average concentration of 36,897 ppm, followed by sodium (Na) with an average concentration of 21,422 ppm. Based on the data collected from offset wells, the Woodbine fluids are expected to be fully compatible with the acid gas injectate.

2.7.3 Fracture Gradient Discussion

For the Woodbine formation, a pressure gradient (PG) of 0.433 psi/ft was used in both simulation modeling and the fracture gradient (FG) calculation. This value is derived from the H-5 form for the Aker Gas Injection Well No. 01, dated November 29, 2024. The H-5 form states that an in-situ pressure gradient of 0.4125 psi/ft can be assumed at the injection well location. This value was increased to a normal PG of 0.433 psi/ft to be conservative in the simulation modeling and FG calculation. The overburden gradient (OBG) was chosen to be 1.05 psi/ft based on industry best practices when site-specific data is limited. Poisson’s ratio of 0.27 was assumed based on the literature of sandstone formations (Molina et al., 2017).

Using the variable values listed previously, an FG of 0.66 psi/ft was calculated, based on the equation shown following Table 5. A 10% safety factor was implemented, resulting in a maximum allowed bottomhole pressure (BHP) of 0.60 psi/ft. This safety factor was set to ensure that the injection pressure never exceeds the fracture pressure of the injection zone.

The Eagle Ford shale above the Woodbine and the Maness Shale below the Woodbine are the confinement zones for injection. For both the upper and lower confining intervals, a similar PG and OBG as the injection interval were assumed. Poisson’s ratio was chosen to be 0.3 for shale and carbonate formations. Shales and carbonates tend to have higher Poisson’s ratios compared to sandstone formations (Molina et al., 2017).

Table 5 provides the inputs and results of the FG calculations for the Aker Gas Injection No. 01 well.

Table 5 – Fracture Gradient calculation inputs and results for the Aker Gas Injection No. 01 well.

Depth (ft)	Zone	Member	Overburden Gradient (psi/ft)	Pore Gradient (psi/ft)	Poisson's Ratio	Fracture Gradient (psi/ft)	90% Fracture Gradient (psi/ft)
3,477	Upper Confining	Eagle Ford	1.05	0.433	0.3	0.70	0.63
3,903	Injection	Woodbine	1.05	0.433	0.27	0.66	0.60
4,397	Lower Confining	Maness	1.05	0.433	0.3	0.70	0.63

Example Fracture Gradient Calculation for Injection Zone of the Woodbine:

$$FG = \frac{\nu}{1 - \nu} (OBG - PG) + PG$$

$$FG = \frac{0.27}{1 - 0.27} (1.05 - 0.433) + 0.433 = 0.66 \text{ psi/ft}$$

$$FG \text{ with SF} = 0.66 \times 90\% = \mathbf{0.60 \text{ psi/ft}}$$

2.8 Upper Confining Zone – Eagle Ford Shale (89 Ma to 94 Ma)

The overlying Eagle Ford shale provides upper confinement of the Woodbine injection zone. The Eagle Ford shale sits immediately below the base of the Austin Chalk, between the depths of 3,477 ft and 3,903 ft in the Aker No. 1. The Eagle Ford/Austin Chalk contact represents a major unconformity at the Turonian/Coniacian (89 manganese [Ma]) boundary (Dawson and Almon, 2010).

In the last 20 years, the Eagle Ford group has been widely recognized as a self-sourcing, self-sealing petroleum system with the advent of modern horizontal drilling of resource plays. The Eagle Ford has historically been viewed as a high-quality source rock for Cretaceous petroleum systems. The excellent source rock character of the Eagle Ford, high organic content (2% to 6% total organic carbon), and cyclic environments of anoxic-to-oxic-to-dysaerobic allow the Eagle Ford shales to be capable of generating large quantities of hydrocarbons. These findings are consistent with other studies that concluded Eagle Ford strata are the principal source rocks for the East Texas Field (Wescott and Hood, 1994).

Regional lithofacies patterns and fossil content indicate a marginal to open marine depositional setting for the Eagle Ford Group; whereby deltas prograding southwestward delivered siliciclastic detritus to the basin. Eagle Ford strata record a mixed siliciclastic-bioclastic depositional system wherein sediments accumulated near and below a storm wave-base on a relatively shallow shelf (proximal setting), which deepened toward the south and southwest (distal setting) (Dawson and Almon, 2010). Figure 16 is a set of representative thin sections of Eagle Ford core samples showing numerous finely interstratified argillaceous, siltstone, and carbonate microfacies, which appear to record high-frequency stratigraphic cycles (Dawson, 1997).

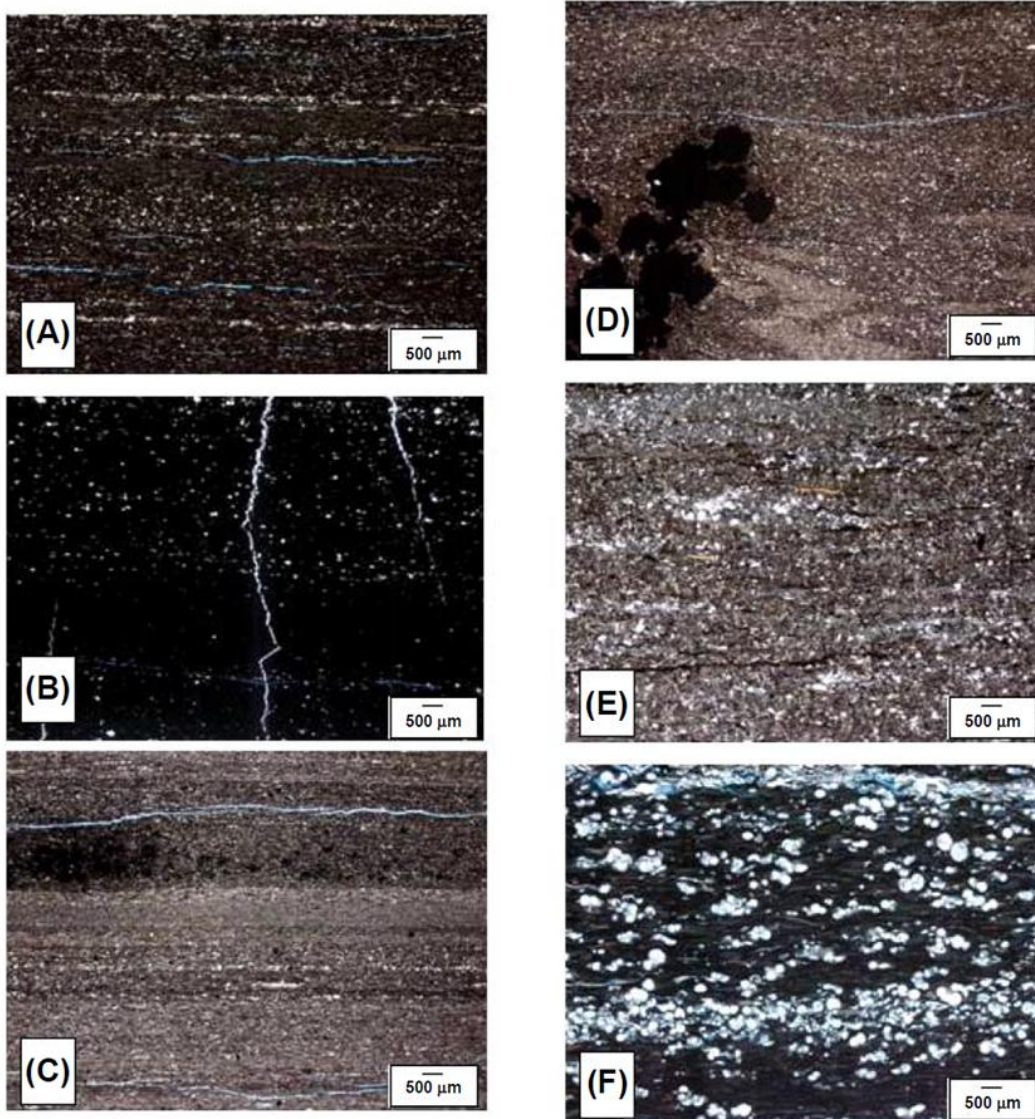

Figure 16 – Representative thin section photographs of Eagle Ford mudstones: (A) finely laminated, moderately silty, carbonaceous shale; (B) calcareous mudstone with calcite-cemented microfractures; (C) interlaminated very silty shale and argillaceous quartzose siltstone; (D) very silty mottled mudstone with authigenic pyrite nodules (lower left); (E) weakly laminated, carbonaceous and argillaceous, quartzose siltstone; and (F) finely laminated, very fossiliferous (foraminifers and phosphatic bioclasts), carbonaceous shale (from Dawson and Almon, 2010).

Figure 17 shows the mineralogical breakdown of Eagle Ford Shale from different oil and gas provinces of the present-day Gulf Coast, where the Eagle Ford is studied extensively for exploration and development purposes. Note the high carbonate (calcite)-to-shale ratio in the distal south-southwest parts of the basin (Maverick-Hawkville-San Marcos); which makes the Eagle Ford brittle in nature and susceptible to fracturing compared to the high clay concentration in the East Texas basin that causes the Eagle Ford to have more ductile characteristics similar to typical clastic shales. Table 6 numerically lists the approximate percentage of the four dominant constituents presented in Figure 17.

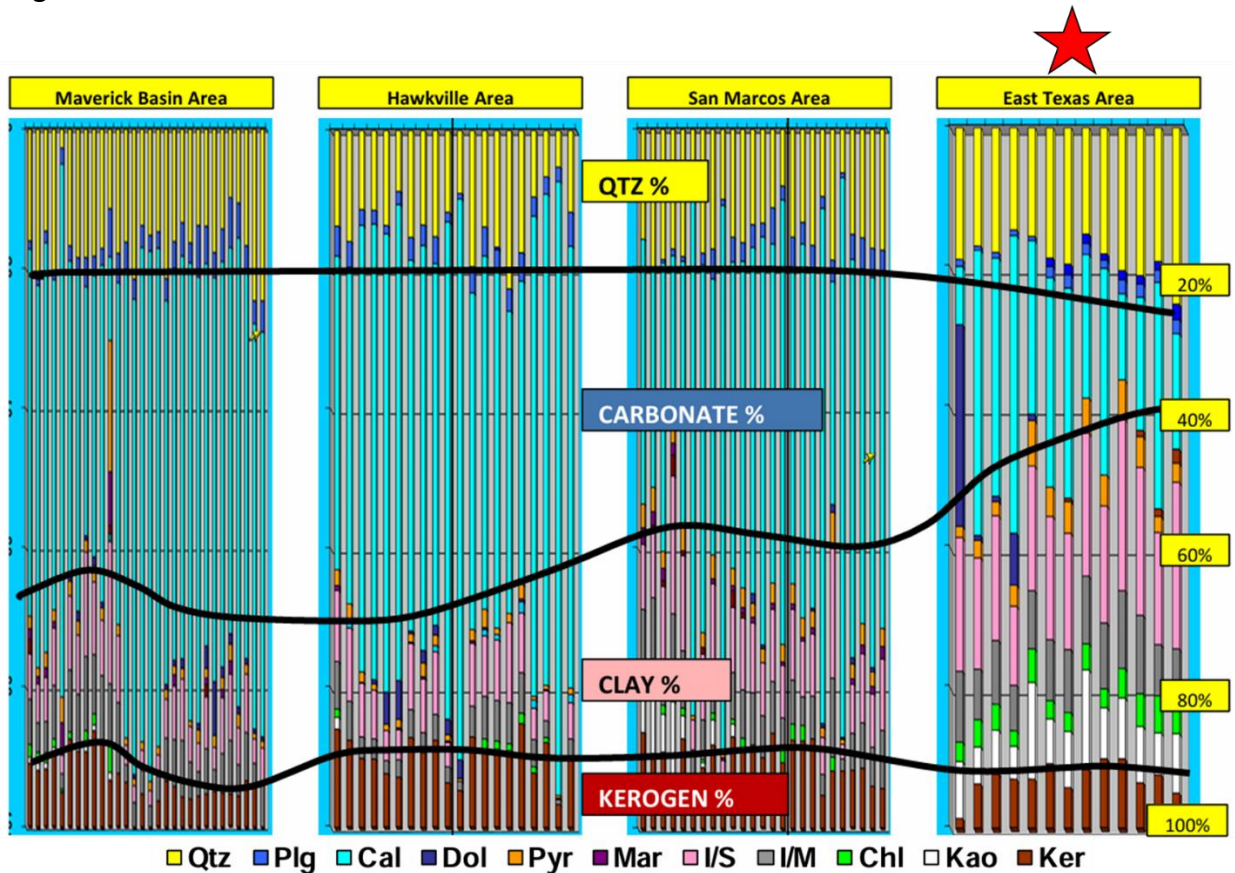

Figure 17 – Representative mineralogical constituents of Eagle Ford shale across different oil and gas regions (Stoneburner, 2014).

Table 6 – Numerical approximations of Eagle Ford shale mineral constituents (values approximated from Stoneburner, 2014).

Eagle Ford Shale (Upper Confining Zone)	
Mineral Constituent	% Framework (by volume)
Clays	50%
Calcite	20%
Quartz	20%
Kerogen	10%

The thickness of the Eagle Ford shale ranges from 372 ft to 426 ft, with an average thickness of 412 ft across the modeled plume area. An isochore map of the UCZ is presented in Figure 18, which shows a general trend of thickening to the east and a local maximum thickness at the Aker No. 1.

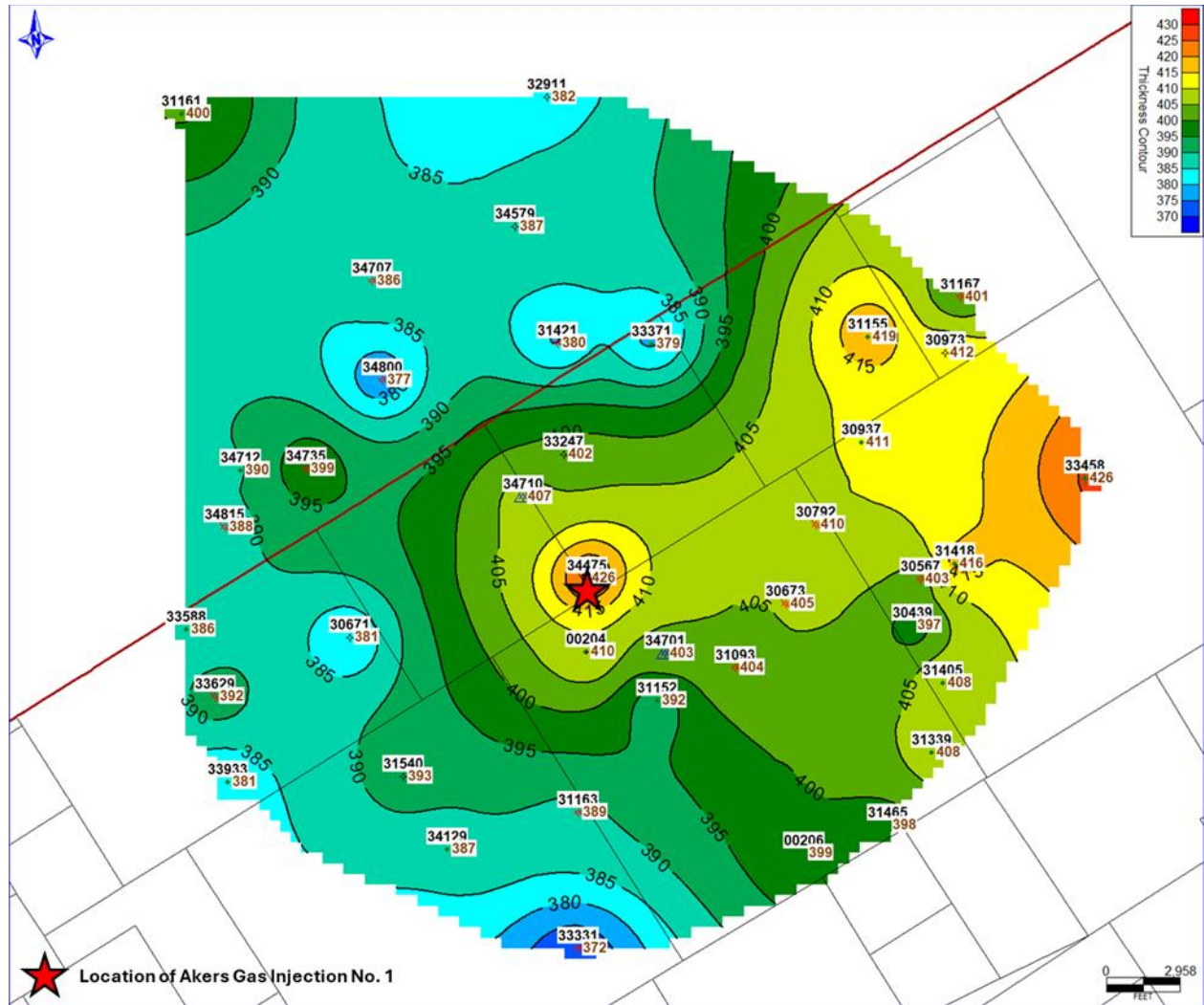

Figure 18 – Isochore map of the Eagle Ford shale, (UCZ).

Without publicly available core data, white paper research was relied on for porosity and permeability estimates of the Eagle Ford confining shale. Ramirez et al. (2016) found Eagle Ford porosities ranged between 0.3% to 10.3%, with an average porosity of 1.4%. A regional Eagle Ford study by Przywara et al. (2011) calculated an average Eagle Ford permeability of 0.0004 mD across 200+ samples. These average porosity and permeability values are in line with other public research papers.

2.9 Lower Confining Zone – Maness Shale (96 Ma to 97 Ma)

The Lower Cenomanian Maness Shale is a clay-rich mudrock originally identified in the East Texas Field, lying between the Woodbine and Buda Limestone, that has been correlated to the basal Lower Eagle Ford in the vicinity of the San Marcos Arch (Patterson and Denne, 2019). While the Maness Shale has the properties to serve as the sole, effective lower confinement, the Buda Limestone provides additional, secondary confinement.

The Maness Shale is black to dark gray, massive to indistinctly laminated mudstone, with sparse to nonexistent foraminiferal laminae (Patterson and Denne, 2019). Core samples of the Maness Shale have revealed encased ash beds that are typical of the interval, which has higher clay content than its shallower equivalent, the Eagle Ford Shale. According to X-ray Diffraction (XRD) mineralogy data published by Patterson and Denne (2019), the constituents of the Maness Shale from order of highest occurrence by weight to lowest include clays, carbonate-calcite, silica, feldspar-micas, and pyrite; specific constituent volumes from core samples can be found in Table 7. The predominant clay type is Illite and Mica (~82%), followed by Kaolinite (~15%), with minimal contribution from Smectite (< 3%).

Table 7 – Mineralogy by XRD of Maness Shale samples (Patterson and Denne, 2019).

Maness Shale (LCZ)	
Mineral Constituent	% Framework (by weight)
Clays	49%
Carbonate-Calcite	22%
Silica	18%
Feldspar-Micas	6%
Pyrite	4%
Ankerite	1%

The thickness of the Maness Shale ranges from 37 ft to 84 ft, with an average thickness of 61 ft across the modeled plume area. An isopach map of the LCZ is presented in Figure 19, which shows a strong trend of thickening to the east; the Maness Shale has a thickness of 60 ft at the Aker No. 1.

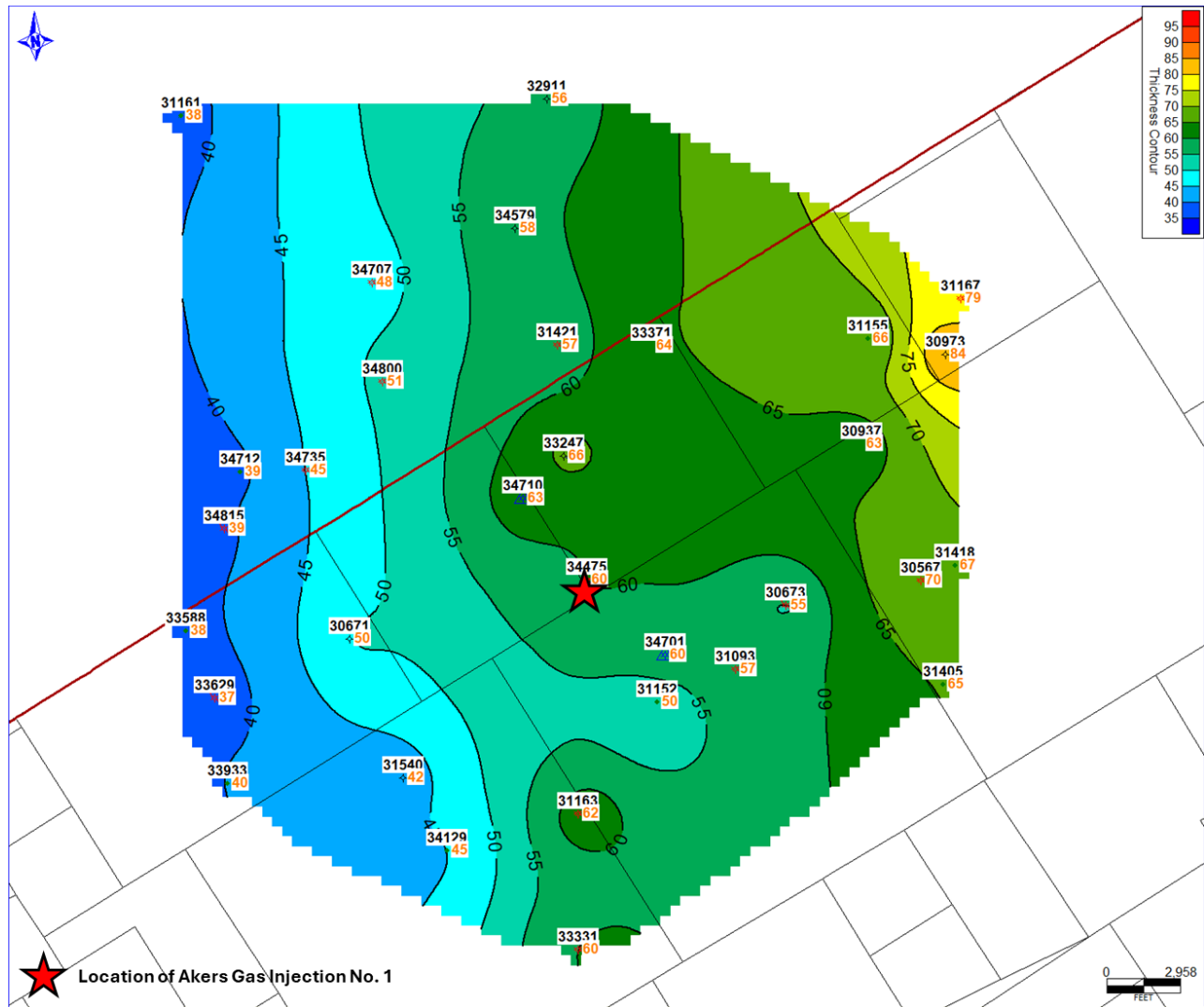

Figure 19 – Isochore map of the Maness shale, lower confining zone (LCZ).

Without publicly available core data, white paper research was relied on for porosity and permeability estimates of the Maness Shale. Because the Maness Shale is correlative to the basal Eagle Ford shale, the same 1.4% average porosity and 0.0004 mD average permeability values from white paper research were assumed for the lower confining shale. Additional confinement is provided from the Buda Limestone with an average computed porosity of 1.5%. The tight nature of the carbonate unit and the capillary pressure contrast with the encasing shales is more than sufficient for preventing fluid migration.

2.9.1 Injection and Confinement Summary

The modeled lithologic and petrophysical characteristics of the Woodbine Formation at the Aker No. 1 agree with findings of regionally published literature and suggest that the injection reservoir provides sufficient pore space required to store the modeled and proposed injection fluids. The

Eagle Ford shale is anticipated to exhibit low permeability throughout the gross overlying section, with sufficient thickness and lateral continuity to serve as the UCZ. Beneath the injection interval, the low permeability, low porosity Maness Shale serves as the LCZ.

Regionally published core data and white paper research were integrated with regional open-hole log data to approximate rock properties for the injection and confinement zones. Site-specific, modern log and historical pressure data at the injection and monitor well locations were also integrated into the reservoir plume modeling to further validate the rock properties from regional data sources. The modeling parameters and methodology are described in greater detail in *Sections 2.14 and 2.15*.

2.10 Local Structure

The Aker No. 1 well is located along the western flank of the East Texas Basin, immediately east of the regional Mexia-Talco Fault System. A TVD subsea (TVDSS) structure map on the top of the Woodbine Formation is provided in Figure 20. The map illustrates the gentle southeastern bed dip (0.7° to 1.1°) of the Woodbine Formation at the Aker No. 1 location. No faulting in the area was observed from the local subsurface data, nor were any regional faults found within the MMA from the publicly available structure maps that were reviewed.

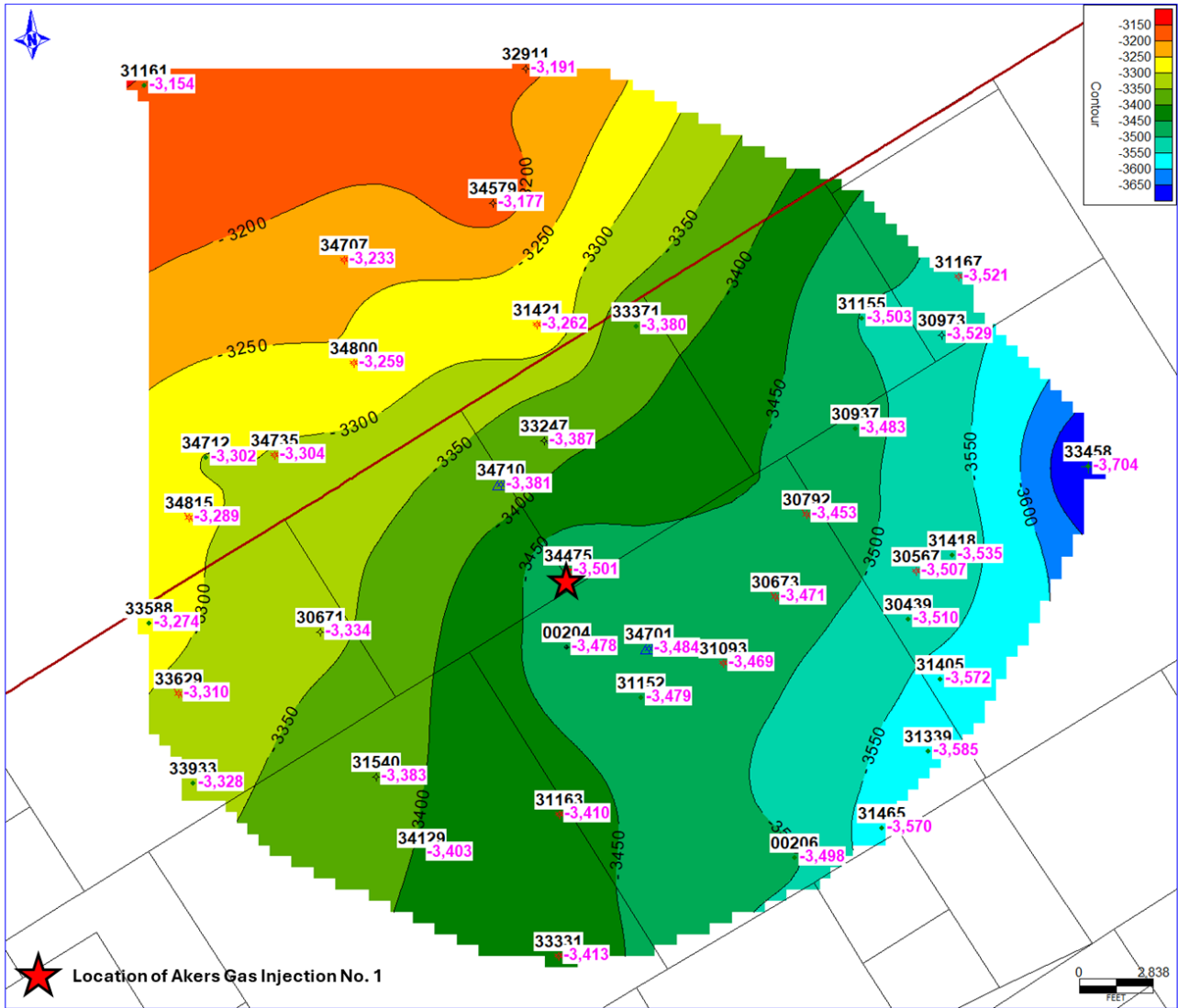

Figure 20 – TVD subsea structure map of the Top of the Woodbine Injection Zone (IZ).

2.11 Groundwater Hydrology

A Texas Aquifer Study published by the TWDB in 2016 identified only one potential major aquifer in the vicinity of the Aker No. 1 location—the Carrizo-Wilcox Aquifer (Bruun et al., 2016). The Carrizo-Wilcox Aquifer is Upper Paleocene to Lower Eocene in age and generally composed of sand with local interbeds of gravel, silt, clay, and lignite. The aquifer consists of the Calvert Bluff, Simsboro, and Hooper Formations of the Wilcox Group; and the Carrizo Formation of the overlying Claiborne Group. Nomenclature of specific sand members within the Wilcox Group varies by region but is clarified in the stratigraphic column provided in Figure 21, which shows the aquifer’s relative position in the geologic section.

		Series	South Texas	Central Texas	Sabine uplift	
Tertiary	Eocene	U	Jackson Group		Jackson Group	
		M	Claiborne Group	Yegua Fm.	Yegua Fm.	Yegua Fm.
				Cook Mountain Fm.	Cook Mountain Fm.	Cook Mountain Fm.
				Sparta Sand	Sparta Sand	Sparta Sand
				Weches Fm.	Weches Fm.	Weches Fm.
				Queen City sand	Queen City sand	Queen City sand
	L	Wilcox Group	Carrizo sand	Carrizo sand	Carrizo sand	
	Upper Wilcox		Calvert Bluff Fm.	Upper Wilcox		
	Paleocene	U	Wilcox Group	Middle Wilcox	Simsboro Fm.	Middle Wilcox
		L		Lower Wilcox	Hooper Fm.	Lower Wilcox
			Midway Formation	Midway Formation	Midway Formation	

Figure 21 – Stratigraphic and hydrogeologic units near Freestone County, Texas (modified from Bruun et al., 2016).

The Carrizo-Wilcox aquifer parallels the present-day coast of the Gulf of Mexico and extends across Texas, from Mexico into Louisiana. Figure 22 shows a statewide map of the major aquifer systems of Texas with the location of the Aker No. 1. Note that the location of the Aker No. 1 falls within an area where the Carrizo-Wilcox aquifer is outcropped at the land surface. Approximately 25% of streamflow in the Carrizo-Wilcox aquifer outcrop areas is attributable to groundwater (Bruun et al., 2016). The aquifer is unconfined to the north where it outcrops, and where confined, is overlain by the low permeability, semi-confining Reklaw Formation.

The aquifer has a general basinward dip to the southeast, and the down-dip extents of the aquifer are defined by the first appearance of regional Wilcox growth faults. The schematic cross section in Figure 23 illustrates the structure of the Carrizo-Wilcox Aquifer and overlying strata relative to the location of the Aker No. 1.

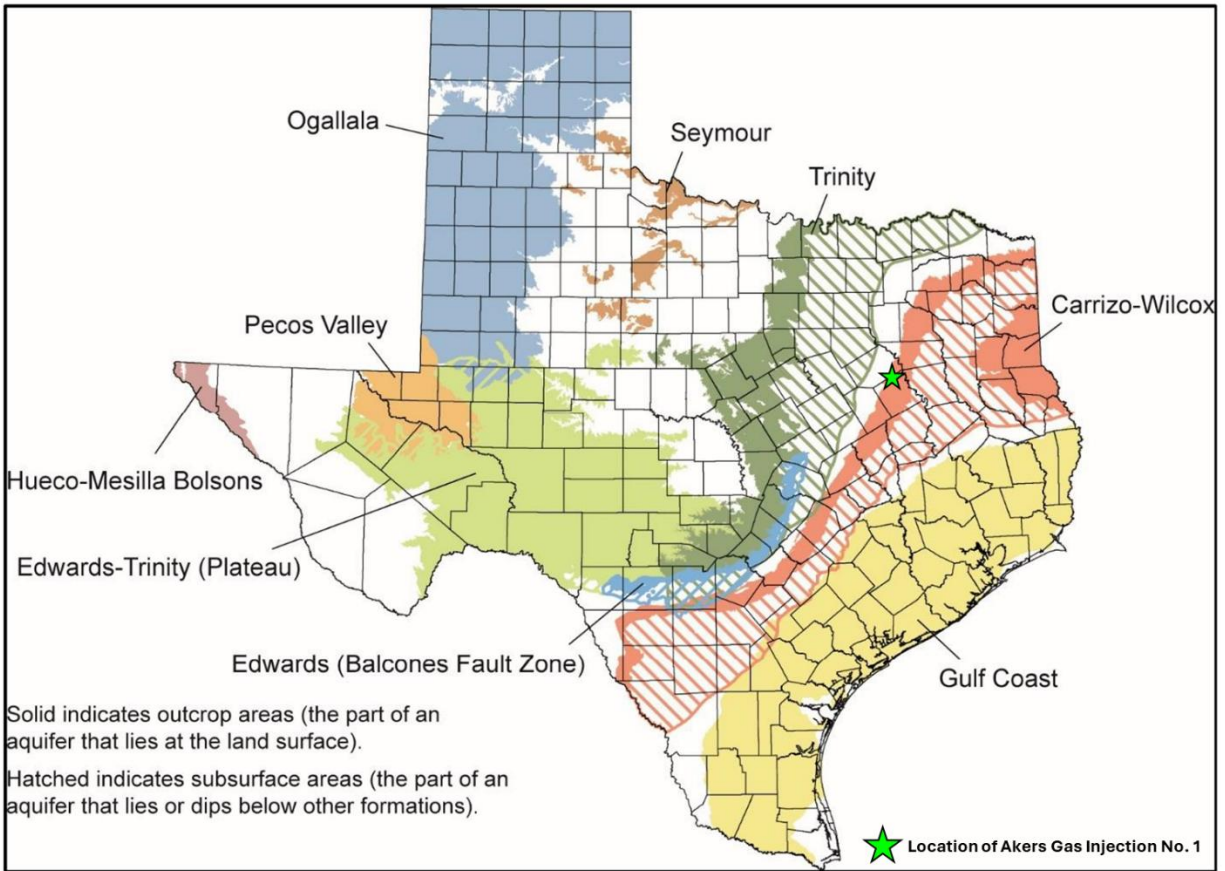

Figure 22 – Map showing the location of the Aker Gas Injection No. 1 relative to the major aquifers of Texas (modified from Bruun et al., 2016).

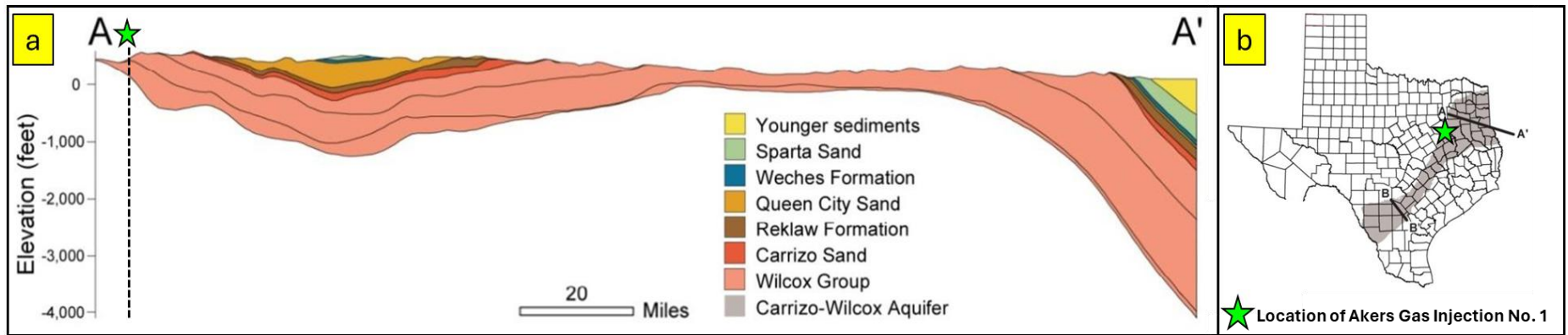

Figure 23 – (a) Structural cross section of the Carrizo-Wilcox Aquifer and overlying strata with the location of the Aker No. 1 projected onto the cross section, and (b) reference map showing the location of the cross section line and Aker No. 1 (modified from Bruun et al., 2016).

The water quality of the aquifer varies aerially as well as with depth, but tends to be brackish to saline in downdip regions of the aquifer and within deeper stratigraphic intervals. According to the TDS map of the Carrizo-Wilcox aquifer, shown in Figure 24, the TDS are approximately 1 milligram per liter (mg/L) to 1,000 mg/L near the Aker No. 1 location; however, concentrations between 1,000 mg/L to 3,000 mg/L are observed in the northeastern corner of Freestone County as well as the central portion of the Freestone-Limestone County border. Carrizo-Wilcox groundwater tends to be hard in unconfined areas and is generally softer where confined by the overlying Reklaw Formation. The primary recharge mechanism is surface recharge from precipitation, but groundwater also interacts with local creeks, streams, and rivers that flow through unconfined portions of the aquifer. This interaction can result in discharge or recharge of groundwater depending on the water level of the aquifer relative to the stage of the river.

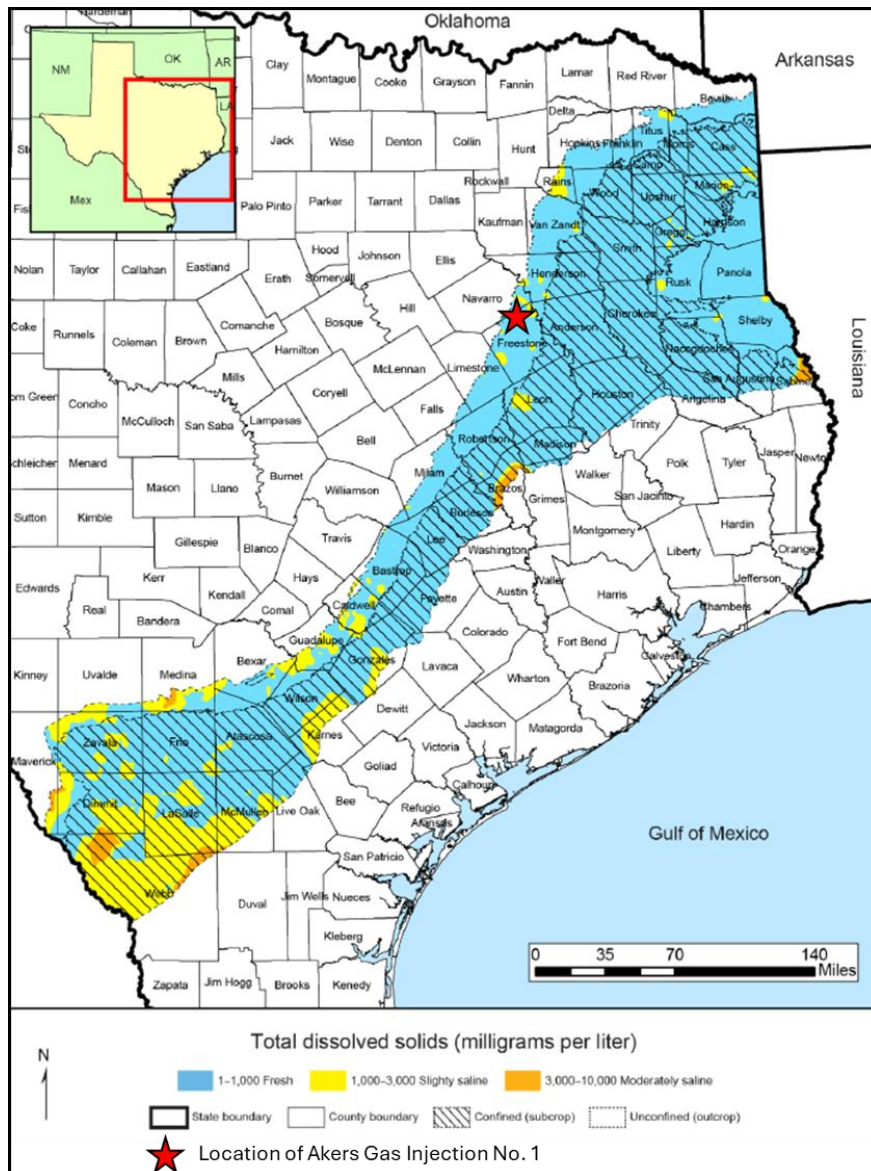

Figure 24 – Total Dissolved Solids (TDS) Map of the Carrizo-Wilcox Aquifer System, showing the location of the Aker No. 1, which is in a predominantly fresh water (< 1,000 mg/L) region.

2.12 Surface Water Hydrology

There are several surface water bodies in Freestone and Navarro Counties near the Aker Plant. These surface water bodies include the Richland-Chambers Reservoir, Fairfield Lake, and the Trinity River.

2.12.1 Richland-Chambers Reservoir

The Richland-Chambers Reservoir is located 3.5 mi north of the Aker No. 1 location. The lake has a surface area of 41,356 acres and a maximum depth of 75 ft, according to Texas Parks and Wildlife. The reservoir was formed by the impoundment of Richland Creek and Chambers Creek east-southeast of the town of Corsicana in 1987. The lake's primary purpose is as a water supply reservoir, with Tarrant Regional Water District (TRWD) having built the reservoir, retaining most of the water rights; the City of Corsicana also holds the rights to a large portion of water from the reservoir, with the right to purchase more. The lake is also used for fishing and recreational purposes.

2.12.2 Fairfield Lake

Fairfield Lake is located 11.5 mi southeast of the Aker No. 1 location and covers a surface area of approximately 2,159 acres. Until 2023, this area was a Texas State Park, but it was closed after several attempts were made by the State of Texas to purchase the park from a Dallas-based real estate developer. The lake is on Big Brown Creek, which is a tributary of the Trinity River that runs roughly north-south, approximately 4 mi east of Fairfield Lake. The lake has historically been used for industrial purposes, specifically thermal-electric power generation, since the authorization of a large dam to impound 50,600-acre/feet of water was issued to TXU Electric Company on May 9, 1968.

2.12.3 Trinity River

The Trinity River runs north-south roughly 12 mi east of the Aker No. 1 location. The river is approximately 710 mi long, which is the longest river with a watershed entirely in the State of Texas. It rises in the far north part of Texas, just a few miles south of the Red River, and flows southeast from Dallas across a fertile floodplain and the pine forests of eastern Texas. The river empties into Trinity Bay, an arm of Galveston Bay that is an inlet of the Gulf of Mexico.

2.13 Base of USDW Determination

The TRRC's Groundwater Advisory Unit (GAU) identified the base of usable-quality groundwater at a depth of 425 ft in the Aker No. 1 well, with the base of the Underground Sources of Drinking Water (USDW) at 3,150 ft. Approximately 3,480 ft of shales, sands, and carbonates separate the base of freshwater from the injection interval; 755 ft of shales, sands, and carbonates separate the lowermost USDW from the Woodbine injection interval, including the regionally continuous and clay-rich Eagle Ford shale (UCZ), which has an average thickness of > 400 ft in the MMA. A copy of

the GAU's Groundwater Protection Determination letter issued by the TRRC as part of the Class II permitting process for the Aker No. 1 well is shown in Figure 25.

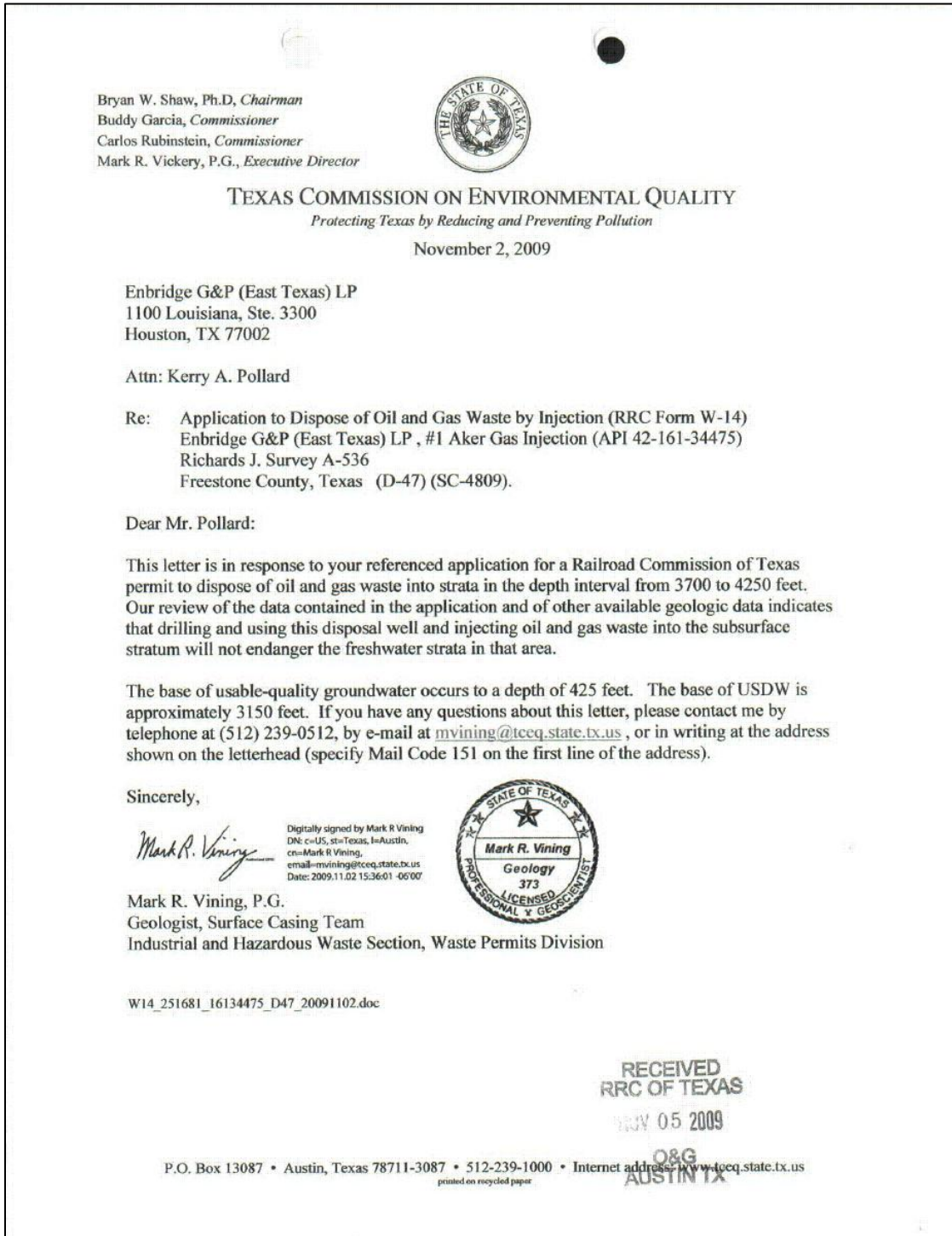

Figure 25 – Groundwater and USDW letter issued as part of the Aker No. 1 Class II permit (accessed from Texas Railroad Commission, February 25, 2025).

2.14 Reservoir Characterization Modeling

Dynamic plume modeling was performed in Rock Flow Dynamic's (RFD) tNavigator version 24.4 (tNav). The model was created using a structure contour map of the top of the Woodbine injection interval and a type log of the injection well to support the permitting of the Aker No. 1 for acid gas injection. The modeling predicts well injectivity, pressure response, and acid gas plume migration. The target injection zone is the Woodbine formation, located at a depth between 3,903 ft to 4,337 ft (TVD).

tNavigator is an advanced reservoir simulation software that seamlessly integrates essential tools for dynamic simulation, data analysis, and reservoir optimization within a single environment. Renowned for its capabilities in modeling compositional fluid flow in both conventional and unconventional reservoirs, its powerful simulator effectively models complex chemical and physical processes, making it a valuable tool for applications like Carbon Capture and Storage (CCS) and acid gas injection.

2.14.1 Reservoir Modeling – Woodbine

The Woodbine Formation is the target formation for Aker No. 1 well. The Petra software package was used to construct a geological model for this target formation. Within Petra, formation top contours were generated for the Woodbine Formation and subsequently brought into tNavigator to depict the geological structure.

Porosity and permeability were determined through analysis of the injector well type log and an extensive literature review (Loucks et al., 2015). The porosity was taken from the type log of the injector well. Each sand package was assigned an average porosity value. Because of a lack of permeability data, the permeability was used as the main variable for history matching the historical injection and pressure data of the injector well, as well as matching plume size based on when the acid gas plume contacted the monitoring well to the north. Permeability values used in the model fall into the range expected to be found in the injection interval. Both the porosity and permeability estimates from the type log and literature are incorporated into the model with the assumption that they exhibit lateral homogeneity for the given layer.

The reservoir is assumed to be at hydrostatic equilibrium. The well is perforated at depths according to the W-2 Completion Report. Each of the three sand packages within the injection interval has an assigned porosity and permeability value based on the type log and history matched permeability, backed by literature (Loucks et al., 2015). The modeled injection interval exhibits an average permeability of 300 mD and an average porosity of 21.2%. These values fall into the range expected back on the previously mentioned literature review. An infinite-acting reservoir has been created to simulate the boundary conditions.

The acid gas injectate is composed of CO₂, H₂S, and trace components of hydrocarbons (C1 – C7), as shown in Table 8. The modeled composition considers CO₂ and H₂S. The gas composition for the proposed injection period remains constant.

Table 8 – Modeled Initial Gas Composition.

Component	Expected Composition (mol %)	Modeled Composition (mol %)
Carbon Dioxide (CO ₂)	98.0	98.0
Hydrogen Sulfide (H ₂ S)	2.0	2.0
Nitrogen and C ₁ – C ₇	<1.0	0.0

Core data from the literature review (Holtz, 2005) was used to determine residual gas saturation and relative permeability curves between carbon dioxide and the connate brine from analogous formations to the Woodbine sandstones (Bachu, 2013). Relative permeability curves were created using the Corey-Brooks method. The key inputs used in the model are provided in Table 9. The relative permeability curves used for the tNavigator model are shown in Figure 26.

Table 9 – Key Inputs to Reservoir Model, Woodbine.

Parameter	Value
Corey exponent, brine	3.0
Corey exponent, gas	2.0
Irreducible brine saturation	60%
Gas permeability at irreducible brine saturation	20%
Maximum residual gas saturation	30%

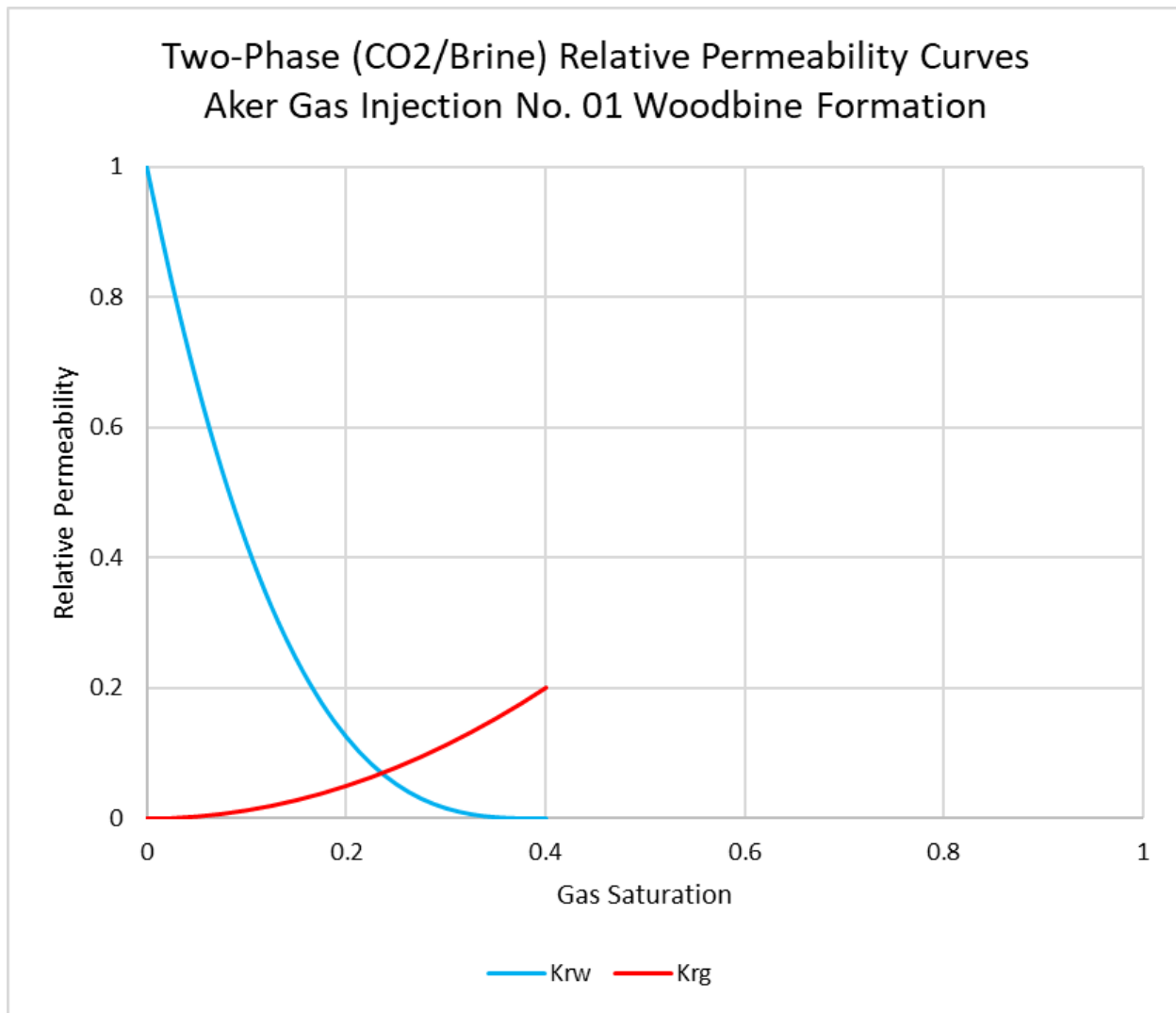

Figure 26 – Two-Phase Relative Permeability Curves Used in the tNavigator Model.

The grid contains 151 blocks in the x-direction (east to west) and 151 blocks in the y-direction (north to south), resulting in a total of 22,801 grid blocks per layer. Each grid block spans dimensions of 250 ft by 250 ft. This configuration yields a grid size measuring 37,750 ft by 37,750 ft, equating to a little more than 51 square miles in area.

In the model, each layer is characterized by homogeneous porosity and permeability values. These values are derived from a porosity log of the Aker No. 1 well and literature review (Loucks et al., 2015). The intervals of sand are assigned to the values from the porosity log and permeability values based on the history match. Values of 5% porosity and 0.001 mD permeability are assigned to shale intervals within the gross injection zone. Upscaled porosity and permeability values from the type log are used to define each layer in the model. These layers are implemented into the model and grouped as “packages,” as seen in Table 10. The model encompasses the entire injection interval, with the top layer being the top of the Woodbine and the bottom layer being the base of the Woodbine. A total of 29 layers are modeled. Sand layers have a thickness of 5 ft.

Table 10 – tNavigator Model Layer Package Properties.

Contour Package	No. of Layers	Top (TVD ft)	Thickness (ft)	Perm. (mD)	Porosity
Sand 1	9	3,903.0	45.0	300	0.20
Shale 1	2	3,948.0	108.0	0.001	0.05
Sand 2	5	4,056.0	26.5	300	0.16
Shale 2	2	4,081.5	62.5	0.001	0.05
Sand 3	8	4,144.0	40.0	300	0.25
Shale 3	3	4,184.0	15.5	0.001	0.05

2.15 Simulation Modeling

The primary objectives of the model simulations were as follows:

1. Estimate the maximum areal extent and density drift of the gas plume after injection.
2. Determine the ability of the target formation to handle the required injection rate without fracturing the injection zone.
3. Assess the likelihood of the gas plume migrating into potential leak pathways.

The reservoir is assumed to be an aquifer filled with 100% brine. The salinity of the formation is estimated to be 69,000 ppm, based on log analysis of the injector and two offset monitoring wells (API #: 42-161-34475, 42-161-34710, and 42-161-34701) and typical for the region and formation (Texas Water Development Board, 1972). The formation temperature gradient is assumed to be 2.7 degrees Fahrenheit (°F) per 100 ft, with an ambient surface temperature of 70°F, and is based on the bottomhole temperature reading at the injector and two offset monitoring wells (API #: 42-161-34475, 42-161-34710, and 42-161-34701). The acid gas stream is primarily composed of CO₂ and H₂S, as stated previously. A literature review was conducted to find a range of porosity and permeability values of the Woodbine that it would be reasonable to assume when conducting the history match (Loucks et al., 2015). As previously mentioned, cores that most closely represent the Woodbine sandstone in this region were identified from literature, and the Corey-Brooks equations were used to develop the curves (Bachu, 2013). A low and conservative residual gas saturation based on the cores from the literature review was then used to estimate the size of the plume (Holtz, 2005).

Because of a lack of permeability data, literature was relied upon to match historical injection and pressure data by adjusting the permeability within the range of possibilities. To achieve this lack of data, the historical gas injection rate was controlled, while historical wellhead pressure (WHP) was variable. After the model was built and all fluid properties listed previously were input, realizations were run, thereby changing permeability until the wellhead pressure was matched to

the best ability of the model. The model had to also take plume migration into account. It is known that the acid gas plume has reached the monitoring well to the north. Permeability within the sand packages were adjusted to best represent the acid gas plume coming into contact the northern monitoring well by time 0 (end of historical injection).

The model is initialized with a reference pressure of 1,691 psig at a subsea depth of 3,500 ft. This pressure, when a Kelly Bushing (KB) elevation of 406 ft is considered, correlates to a gradient of 0.433 psi/ft. Based on the latest H-5 form, dated November 29, 2024, the BHP gradient was calculated to be 0.4125 psi/ft at the Aker Monitor Well No. 02. The choice to use the freshwater gradient of 0.433 psi/ft as the in-situ reservoir pressure gradient was made to be a conservative estimate of the reservoir pressure. The reservoir pressure is directly correlated, along with injection rate, to the surface injection pressure. The FG of the injection zone was estimated to be 0.66 psi/ft, using Eaton's method. A 10% safety factor was then applied to this number, placing the maximum BHP allowed in the model at 0.60 psi/ft, which is equivalent to 2,324 psig at the top of the Woodbine injection interval. The maximum allowable surface injection pressure (MASIP) is 1,850 psig. By using an in-situ reservoir pressure gradient of 0.433 psi/ft, a conservative estimate of wellhead pressure is output during injection.

The model, which began in April 2012, runs for 49.667 years, comprising 12.667 years of historical injection and 12 years of anticipated injection, and is then succeeded by 25 years of density drift. Throughout the historical 12.667-year injection period, a variable injection rate is injected based on the reported monthly injection from the annually submitted H-10 forms. Then, a maximum rate of 9 MMscf/d is injected for 12 years of anticipated injection, yielding the largest estimate of the plume size. After the 24.667-year injection period, when Aker No. 1 ceases injection, the density drift of the plume continues until the plume stabilizes 25 years later. The maximum plume extent during the 24.667-year injection period is shown in Figure 27. The final extent after 25 years of density drift after injection ceases is shown in Figure 28.

The cross-sectional view of the Aker No. 1 shows the extent of the Woodbine plume from a side-view angle, cutting through the formation at the wellbore. Figure 29 shows the maximum plume extent during the 24.667-year injection period. During this time, gas is injected into the permeable layers of the formation and travels predominantly laterally. Figure 30 shows the final extent of the plume after 25 years of migration. At this point in time, the effects of residual gas saturation and migration caused by density drift are clearly shown. At least 25% of the injected gas that travels into each grid cell is residually trapped as the gas travels mostly vertically, because the gas is less dense than the formation brine, until an impermeable layer is reached. Because of the dense nature of the formation brine, the plume migrates vertically upward and less laterally. Both figures are shown in a west-east view.

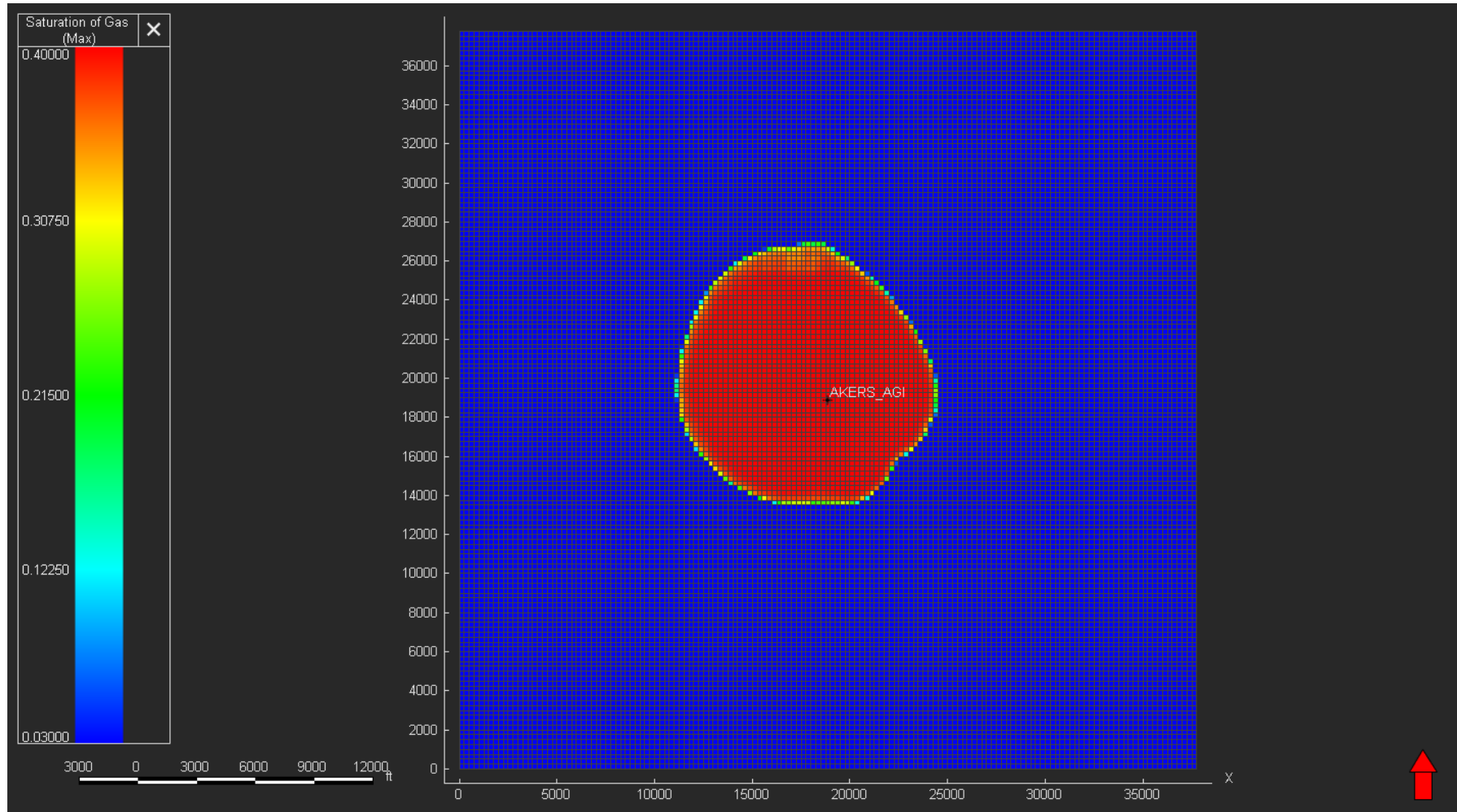

Figure 27 – Areal View of Woodbine Gas Saturation Plume at Shut-in (End of Injection).

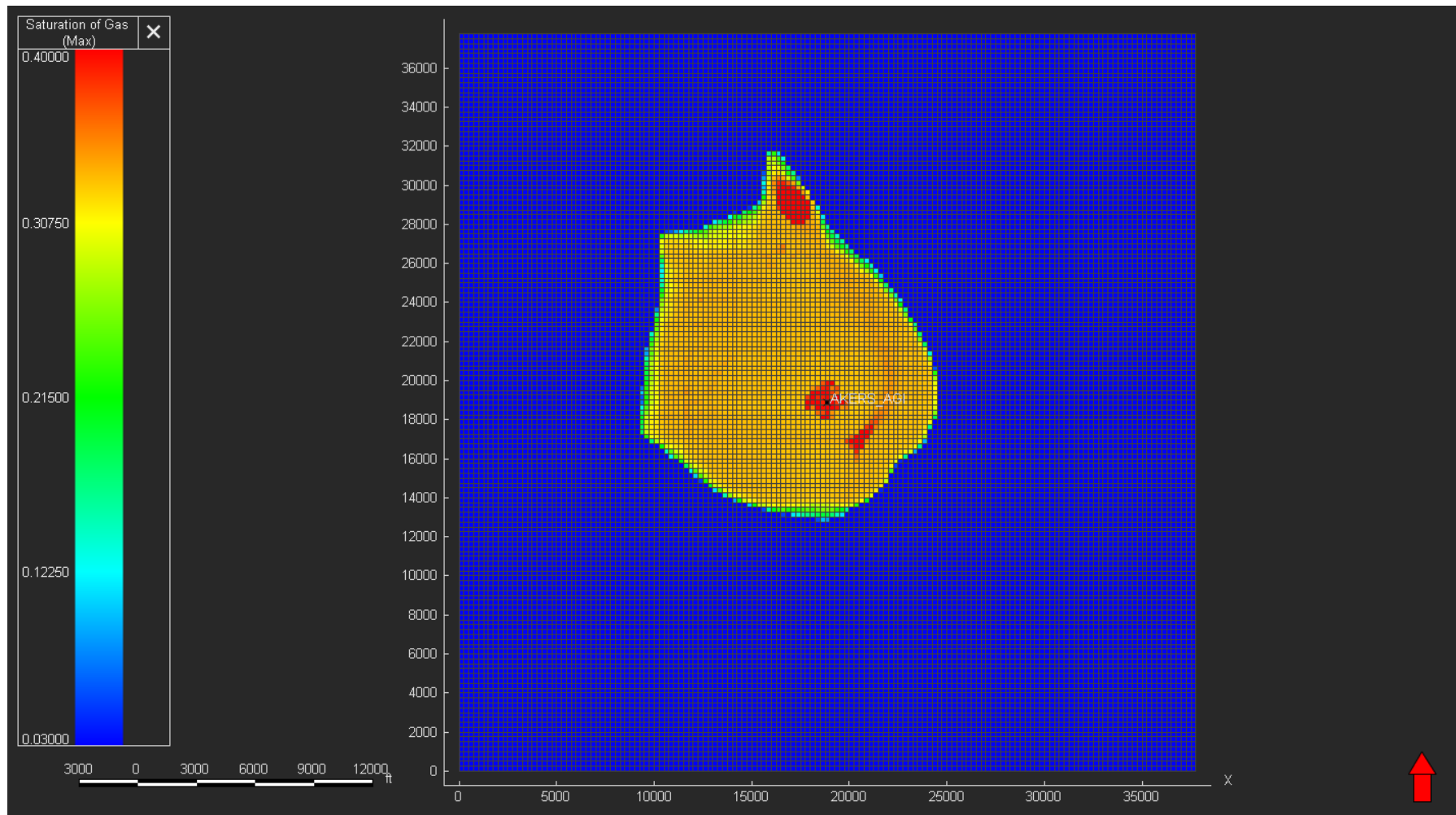

Figure 28 – Areal View of Woodbine Saturation Plume at 25 Years After Shut-in (Stabilized).

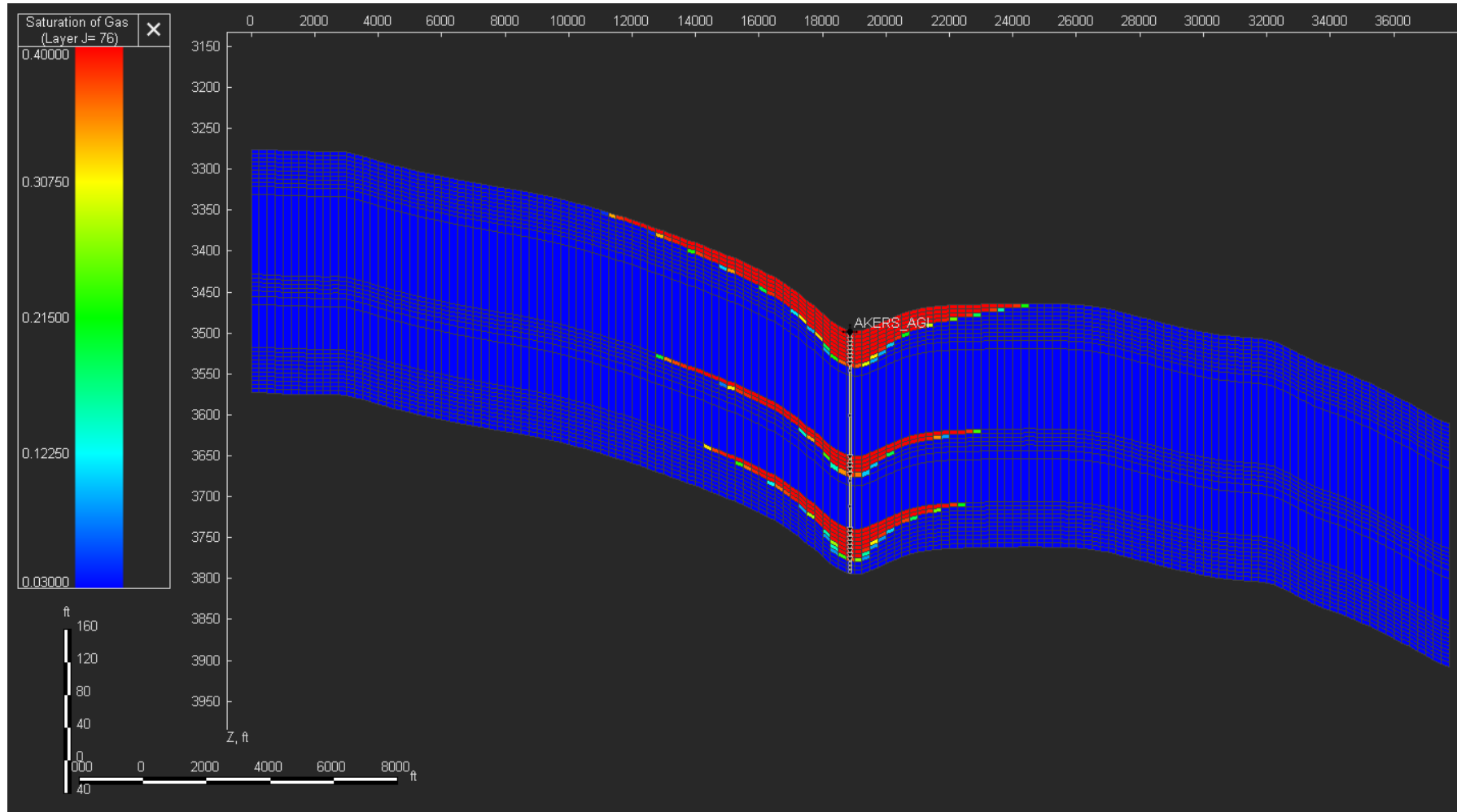

Figure 29 – West-East Cross-Sectional View of Woodbine Gas Saturation Plume at Shut-in (End of Injection).

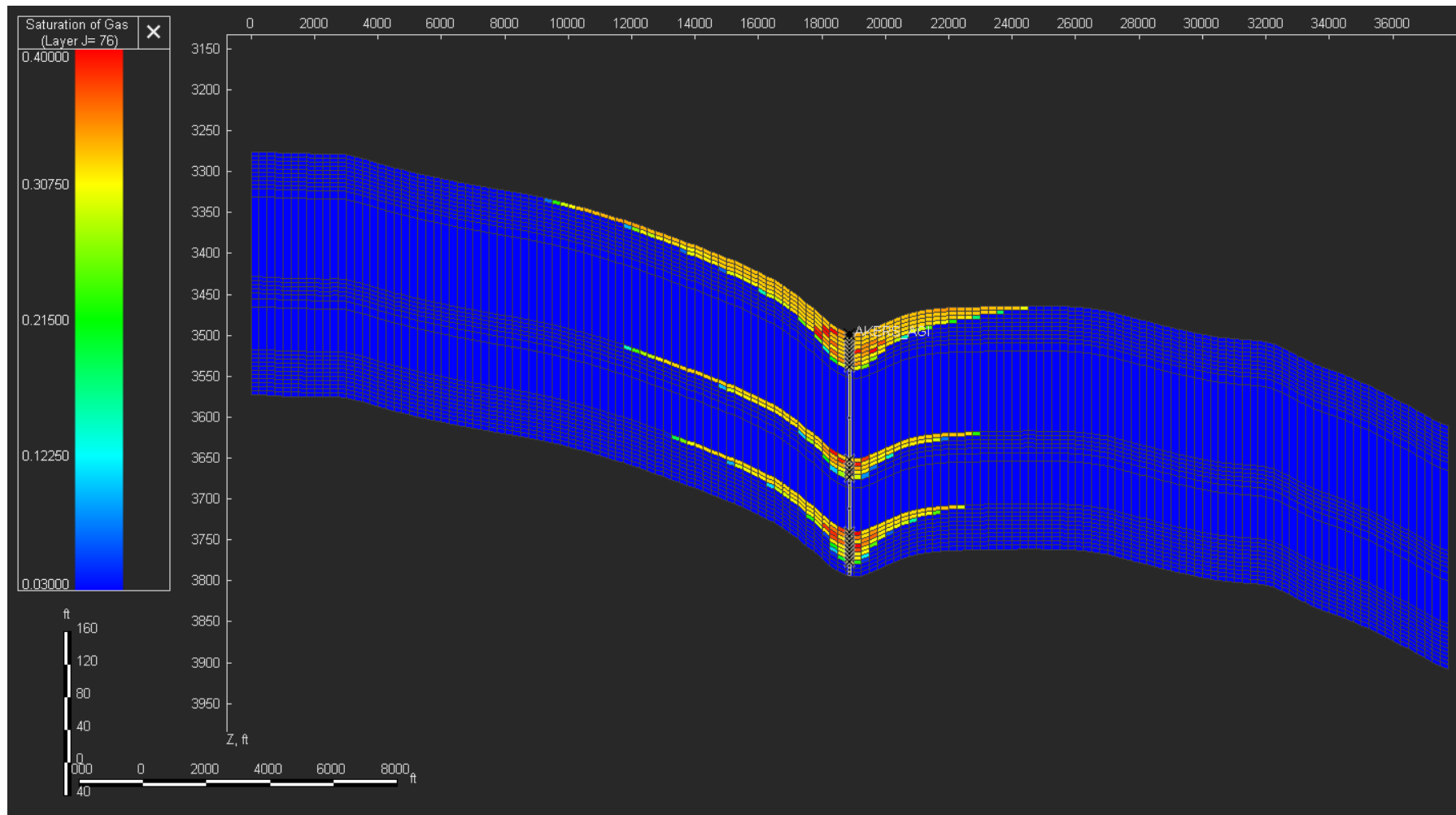

Figure 30 – West-East Cross-Sectional View of Woodbine Gas Saturation Plume at 25 Years After Shut-in (Stabilized).

Figure 31 shows the surface injection rate, BHP, and wellhead pressure (WHP) during the historical and future injection period. The modeled WHP was historically matched using permeability to resemble the historical WHP data. The BHP reaches a maximum of 1,866 psig at the end of injection. This buildup of 175 psig stays well below the 90% fracture pressure constraint of 2,324 psig. The maximum WHP associated with the maximum BHP reached is 1,075 psig, which is less than the maximum allowable 1,850 psig as set in the UIC permit application for this well. Table 11 shows the BHP during historical and future injection, as well as post-injection to show reservoir pressure stabilization.

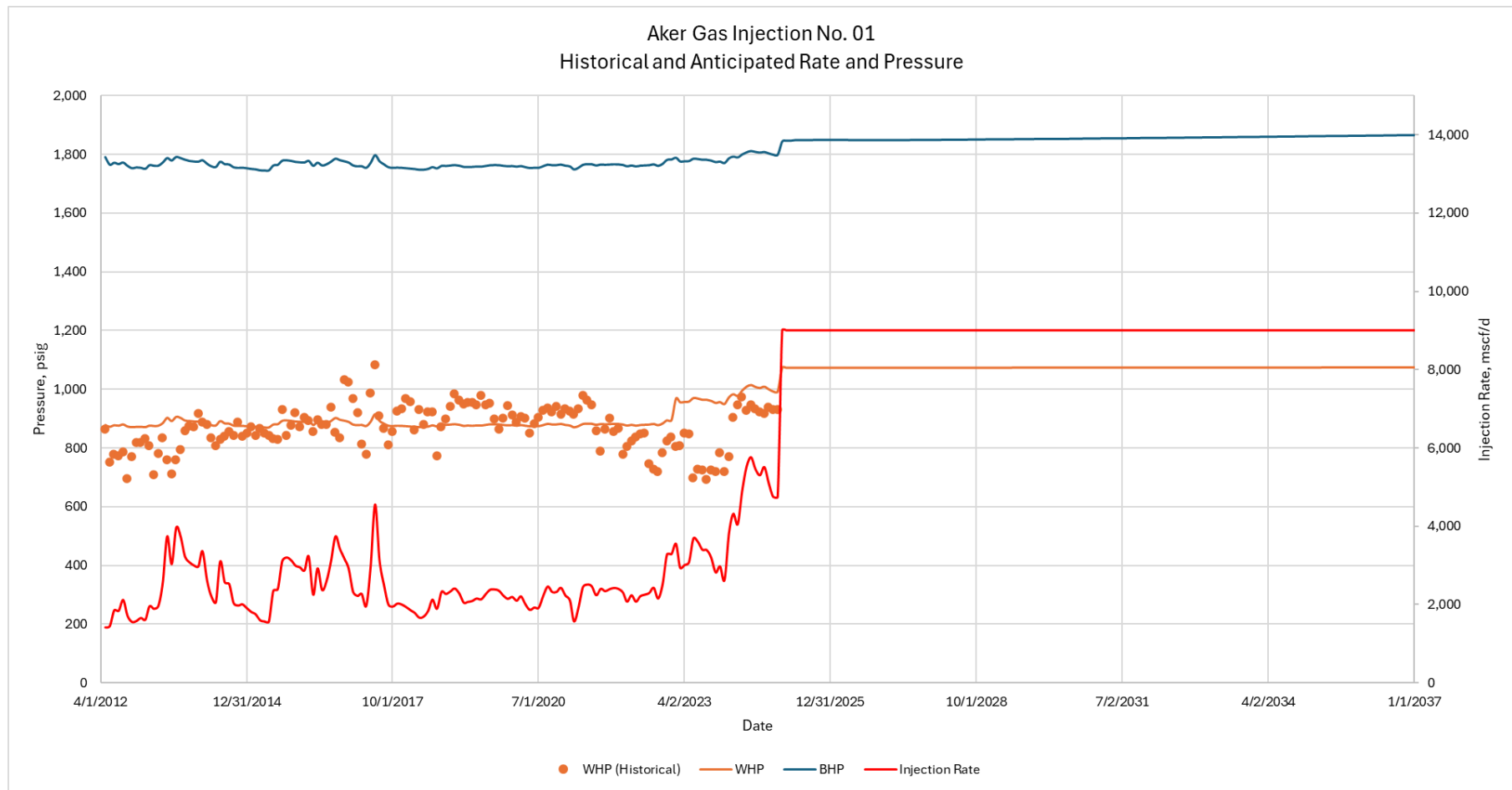

Figure 31 – Well Injection Rate and Bottomhole and Surface Pressures Over Time, Woodbine.

Table 11 – Historical and Future BHP

Time	Date	Bottomhole Pressure, psig
Start of Historical Injection	4/1/2012	1,690
	1/1/2015	1,753
	1/1/2020	1,761
Start of Maximum Permitted Injection	1/1/2025	1,800
	1/1/2028	1,851
	1/1/2031	1,855
	1/1/2034	1,860
End of Injection	1/1/2037	1,866
	1/1/2042	1,737
	1/1/2047	1,740
	1/1/2052	1,743
	1/1/2057	1,743
Plume Stabilization	1/1/2062	1,741

SECTION 3 – DELINEATION OF MONITORING AREA

The delineation of the Maximum Monitoring Area (MMA) and the Active Monitoring Area (AMA), as described in EPA 40 CFR §98.448(a)(1) is discussed in this section.

3.1 Maximum Monitoring Area

The MMA is defined as equal to or greater than the area expected to contain the free-phase CO₂ plume until the plume has stabilized, plus a surrounding buffer zone of at least one half mile, as shown in Figure 32. Numerical simulation was used to predict the size and drift of the plume. Reservoir modeling was used to determine the areal extent and density drift of the plume, as described in *Section 2.15*. The model considers the following:

- Offset well logs to estimate geologic properties
- Petrophysical analysis to calculate the heterogeneity of the rock
- Geological interpretations to determine faulting and geologic structure
- Offset injection history to adequately predict the density drift of the plume

Plume stabilization is deemed to have occurred when the rate of growth or positional change of the plume size year over year becomes indiscernible. The stabilization of the plume is determined by the model output, when the areal growth rate drops below 0.25% size per year.

3.2 Active Monitoring Area

The AMA boundary is established by superimposing two areas: (1) the anticipated plume boundary at the end of injection operations, which is year 12 (t), plus a buffer zone of one half mi, with (2) the area projected to contain the free-phase CO₂ plume at the end of year (t + 5). The AMA is represented by the dashed green boundary in Figure 32.

At cessation of injection operations in Year 12, the anticipated areal extent of the plume will be approximately 3,263 acres, and the AMA's extent is 6,417 acres. After an additional 25 years of density drift, and the plume has stabilized, the predicted areal extent of the MMA is 8,364 acres. Figure 32 shows the plume area at the end of 25 years (stabilization) represented by the red line area, plus a one half mile buffer represented by the dashed red line (MMA). As a result of the small difference between the AMA and the MMA, Midcoast G&P has elected to set the AMA equal to the MMA.

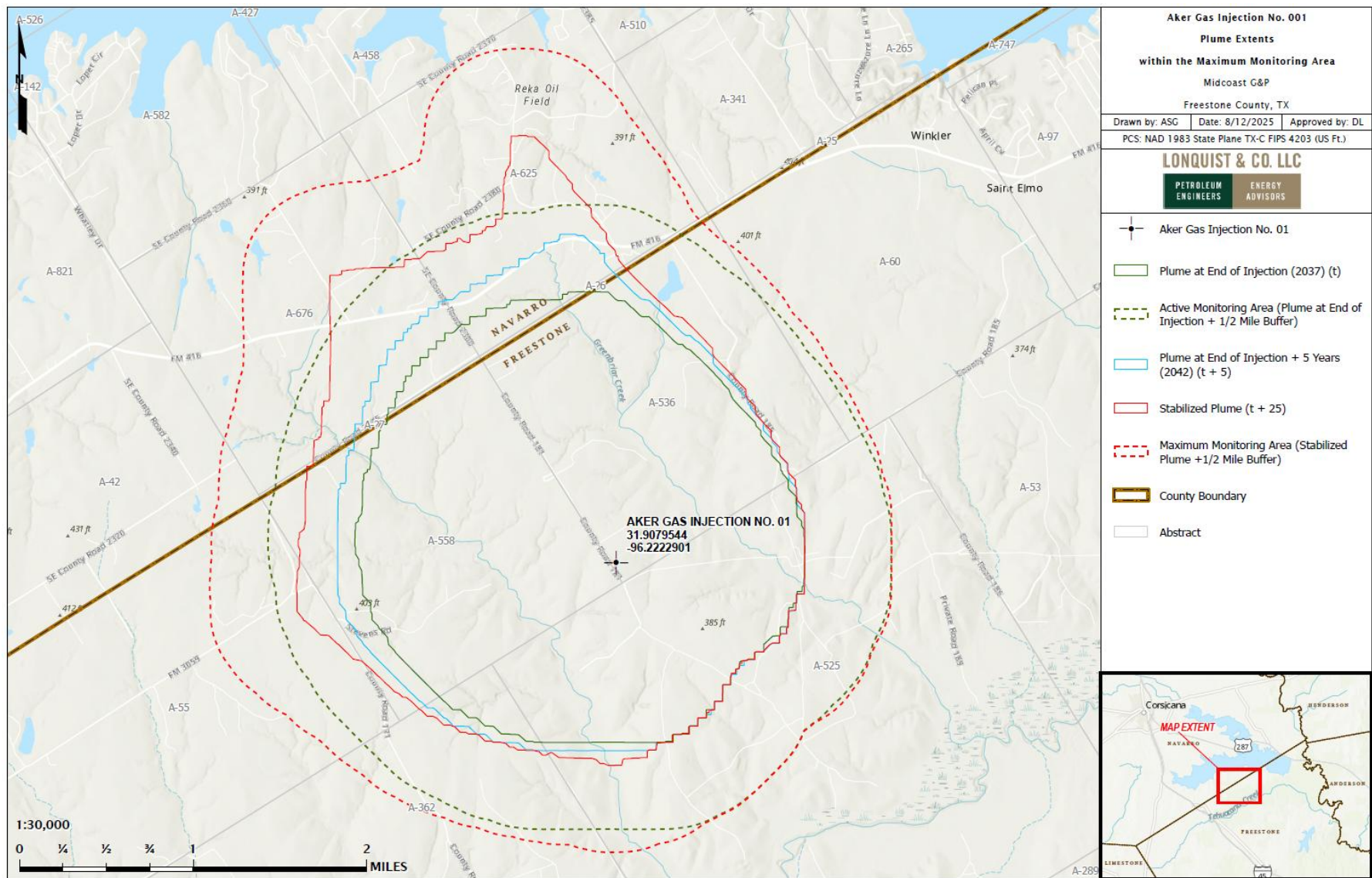

Figure 32 – Delineation of Maximum Monitoring Area.

SECTION 4 – POTENTIAL PATHWAYS FOR LEAKAGE

Potential CO₂ leakage pathways to the surface within the MMA are identified in this section and evaluated for likelihood, magnitude, and timing. A summary of these paths is provided in Table 12. The potential leakage pathways include the following:

- Leakage from surface equipment
- Leakage from existing wells within MMA
- Leakage from future drilling in MMA
- Leakage through faults and fractures
- Leakage through the Confining Zones
- Leakage from natural or induced seismicity

Table 12 – Potential Leakage Pathway Risk Assessment

Potential Leakage Pathway	Likelihood	Magnitude	Timing
Surface Equipment	Possible during injection operations.	Low. SCADA systems will detect leaks and execute safety shutdown procedures.	During active injection.
Existing wells within the MMA	Low. Twenty-seven wells penetrate the Upper Confinement within the MMA. Only seven of these wells are within the stabilized plume.	Low. Multiple upper confining intervals and the TRRC SWR 13 completion requirements mitigate the risk of CO ₂ migration to the USDW and surface releases.	During active injection and until the plume stabilizes 25 years after injection ceases.
Future wells within the MMA	Low. The area is active with oil and gas production. Most well locations within the MMA have already be drilled.	Low. TRRC requires that any new wells penetrating the injection intervals be constructed in compliance with SWR 13 to prevent migration of CO ₂ . Additionally, there are multiple confining zones above the injection zone.	During active injection and until the plume stabilizes 25 years after injection ceases.
Faults and fractures	Low. No faults or fractures were identified in the Area of Review.	Low. Multiple Confining Zones should contain any leakage that would migrate through faulting.	During active injection and until the plume stabilizes 25 years after injection ceases.
Confining Zones	Low. The Confining Zones have sufficient thickness, continuity, and confining characteristics.	Low. Leakage out of the injection interval is unlikely due to multiple Confining Zones.	During active injection and until the plume stabilizes 25 years after injection ceases.

Potential Leakage Pathway	Likelihood	Magnitude	Timing
Natural or induced seismicity	Low. A review seismic data shows no earthquakes of magnitude 2.0 or greater within 9.08 km radius, indicating a low probability of a seismic event.	Low. The Confining Zones should prevent migration out of the injection intervals in the event of induced seismicity.	During active injection and until the plume stabilizes 25 years after injection ceases.

Magnitude Assessment Description
Low - categorized as little to no impact to safety, health and the environment and the costs to mitigate are minimal.
Medium - potential risks to the USDW and for surface releases does exist, but circumstances can be easily remediated.
High - danger to the USDW and significant surface release may exist, and if occurs this would require significant costs to remediate.

These potential leakage pathways have the highest risk of leakage during the injection period. After the injection ceases in 2037, the risk of leakage from offset wells, fractures, etc., is reduced until the plume fully stabilizes in 2062 based on the plume model. The risks associated with leakage from the surface equipment are to be eliminated after the injection wells are plugged and the associated surface equipment is removed.

4.1 Leakage from Surface Equipment

The Aker Plant and the Aker No. 1 well are existing facilities that have been in operation since 2010. These facilities are well-maintained and have a positive operating history for compliance and safety.

The sour gas stream is treated in the amine unit and separated into a sweet gas stream and an acid gas stream as depicted in Figure 33. The acid gas stream is then compressed, measured with the gas meter, and transported to the Aker No. 1 via pipeline for injection. The pipeline and wellhead are potential sources of leakage during injection operations, as the flanged connections and valves are the most likely failure points of the surface equipment. Additionally, damage may occur if any of the surface equipment is compromised due to an accident, corrosion, or a natural disaster, resulting in the release of the injectate.

Gas detectors for H₂S are installed at key locations within the facility, as shown in the site plan in Figures 41 and 42 and Appendix B. These devices are continuously monitored by the Supervisory Control and Data Acquisition (SCADA) system and will alarm at set points based on H₂S exposure limits as recommended by the Occupational Safety and Health Administration (OSHA).

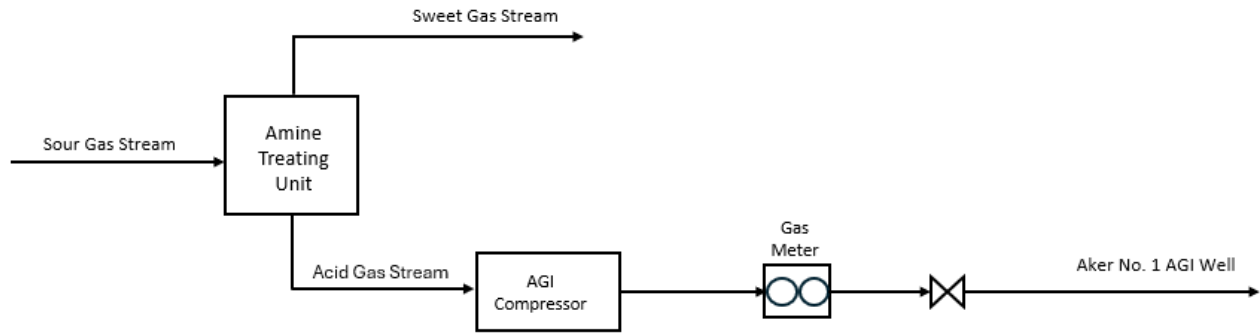

Figure 33 – Aker No. 1 Process Flow Diagram

4.2 Leakage from Wells in the MMA

4.2.1 Existing Wells Within the MMA

The Aker AGI wells are designed to prevent migration from the injection interval to the surface through a special casing and cementing design as depicted in the schematic provided in Figure 34. The annular spaces between the injection tubing and the long string casing are filled with an inert corrosion-inhibiting fluid as a further safety measure. A successful mechanical integrity test (MIT) is required under TRRC's 16 Texas Administrative Code (TAC) **§3.9** and **§3.46** before injection operations can begin. To maintain compliance, Class II AGI wells must undergo an MIT at least once every five years. Under Permit Amendment 13099, Midcoast G&P has agreed to perform an annual MIT on the Aker No. 1. A successful MIT demonstrates that there are no significant leaks in the casing, tubing, or packer and that the well is properly isolated from the USDWs. An unsuccessful MIT would indicate the potential of a leak; the well would be isolated, and the leak mitigated to prevent leakage of the injectate into another formation or to the atmosphere.

Research of the MMA yielded 35 oil and gas wells in the area. In review of these wells, 27 penetrate the upper confinement. The remaining 8 wells were either too shallow to penetrate the upper confinement or had expired permits and were never drilled. A map of all oil and gas wells found within the MMA is shown as Figure 35. The MMA review map and a summary list of the oil and gas wells in the MMA are provided in Appendix C.

In this area, most of the drilling activity targets the Cotton Valley, Bossier, and Rodessa formations, which occur at depths of between 10,000 ft and 11,500 ft; significantly deeper than the Woodbine Formation. Well completions to this depth will typically have two casing strings cemented through the Woodbine, providing an additional layer of safety against possible corrosion.

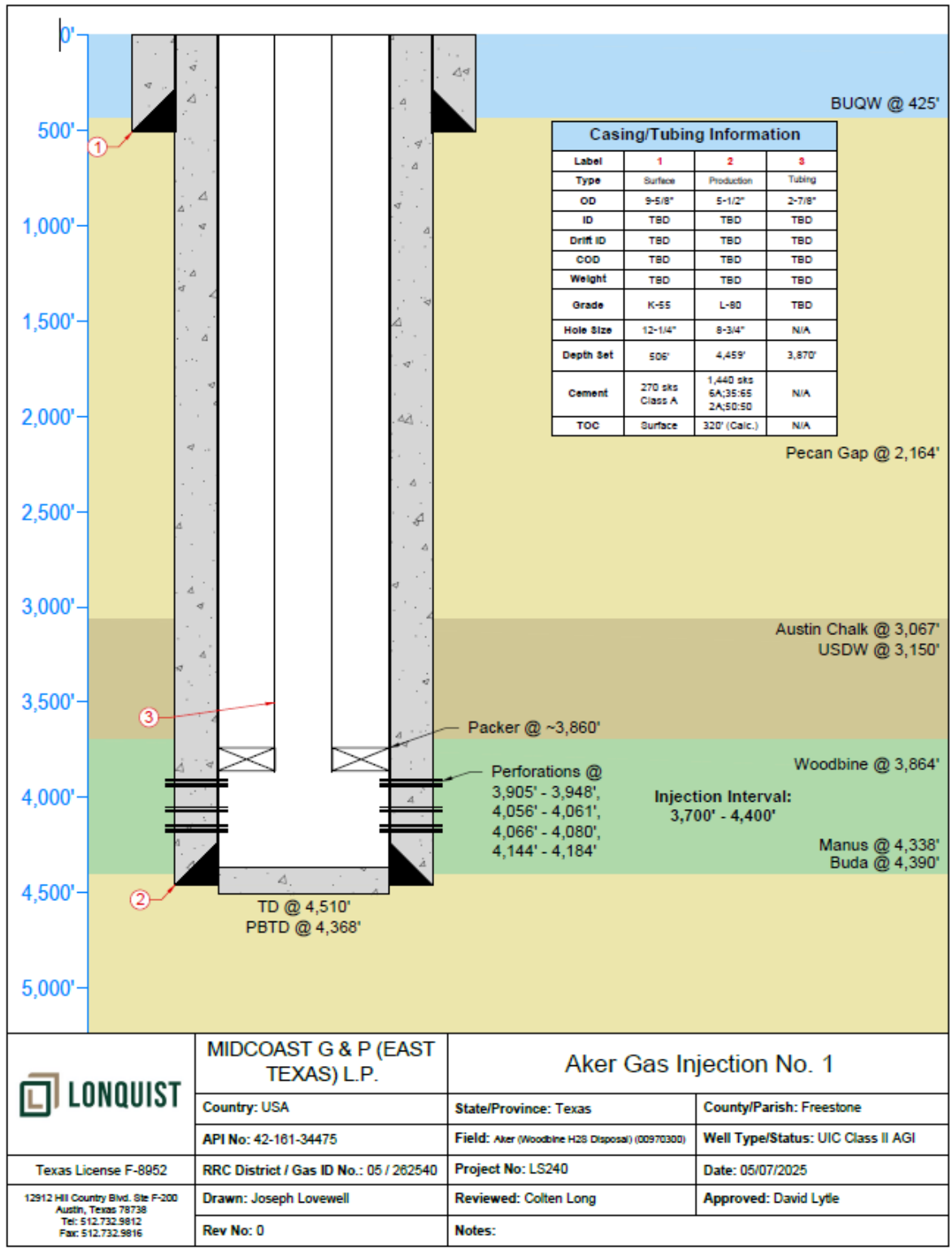

Figure 34 – Aker Gas Injection No. 1 Wellbore Schematic

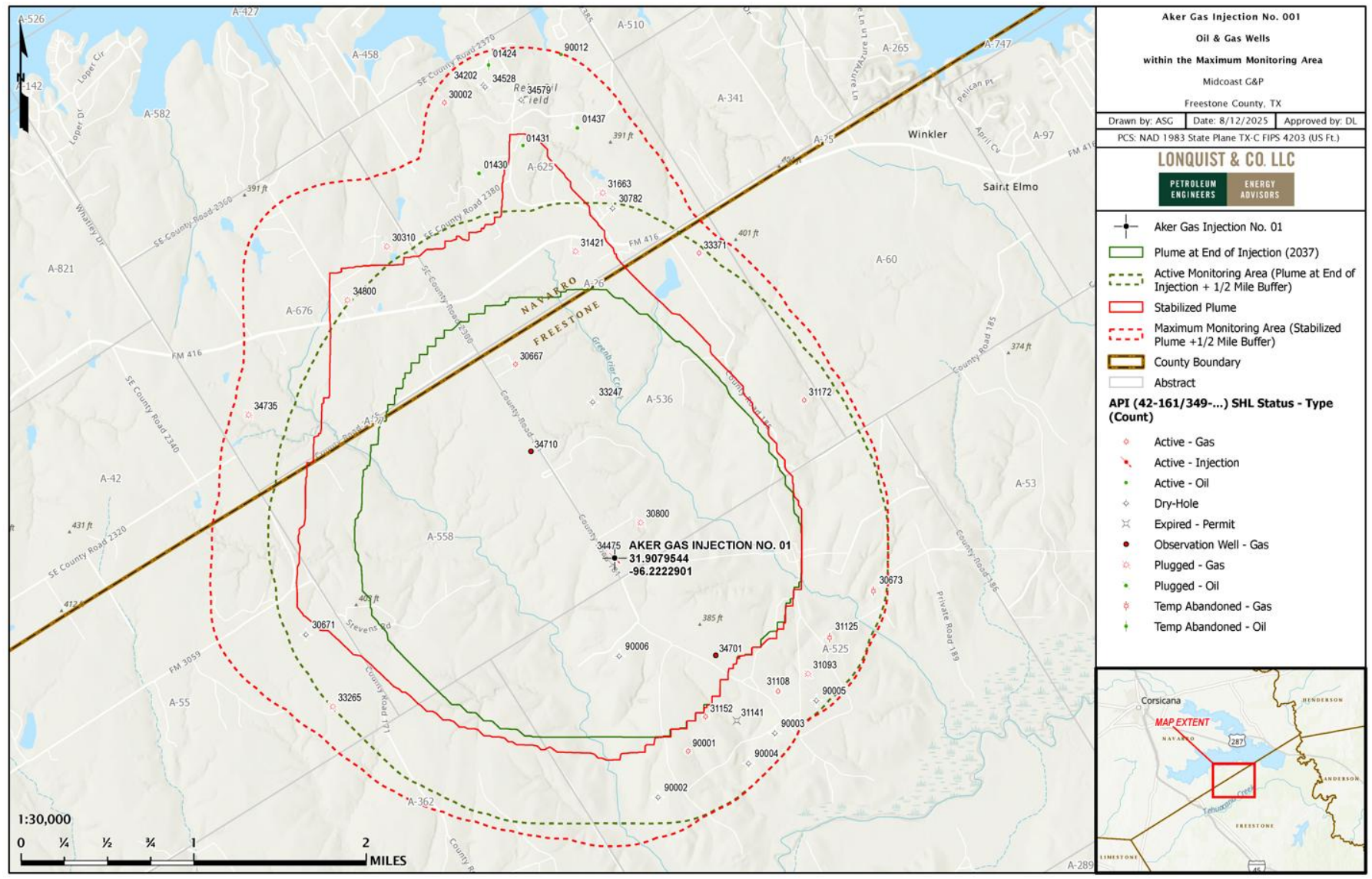

Figure 35 – All Oil and Gas Wells Within the Maximum Monitoring Area

4.2.2 Future Drilling

New wells drilled within the MMA will be required to comply with TAC Title 16, Part 1, Chapter 3, Section 3.13, which is titled (Casing, Cementing, Drilling, Well Control, and Completion Requirements). The rule establishes standards to prevent the waste of oil, gas, or geothermal resources and to protect usable quality water from contamination during drilling and production activities. For any wells drilled for oil or gas with surface and intermediate casing, the regulations require casing to be set at specific depths and cemented adequately to isolate productive zones, unusable water zones, and other subsurface formations. Midcoast G&P will monitor for any new permits and coordinate with the operator to ensure that if a proposed well may intersect the CO₂ plume that it will be constructed in a manner to prevent migration above the injection interval.

4.2.3 Freshwater Wells

A groundwater well search in the area identified 16 wells within the MMA, identified by the TWDB, shown in Figure 36, and a list of these wells is provided in Appendix C. The deepest of these wells has a total depth of 163 ft, which is significantly shallower than the UCZ of the Woodbine injection interval.

The surface casing for the Aker No. 1 is set at a depth of 506 ft and is cemented to surface, sufficiently below the Base of Usable Quality Water at 425 ft as shown in Figure 34, designed to isolate and protect the shallow freshwater aquifers, consistent with applicable TRRC regulations for this area. The wellbore casings and cement also prevent CO₂ leakage to the surface along the borehole. Midcoast G&P believes that leakage of CO₂ from the Woodbine Formation to the groundwater wells is unlikely.

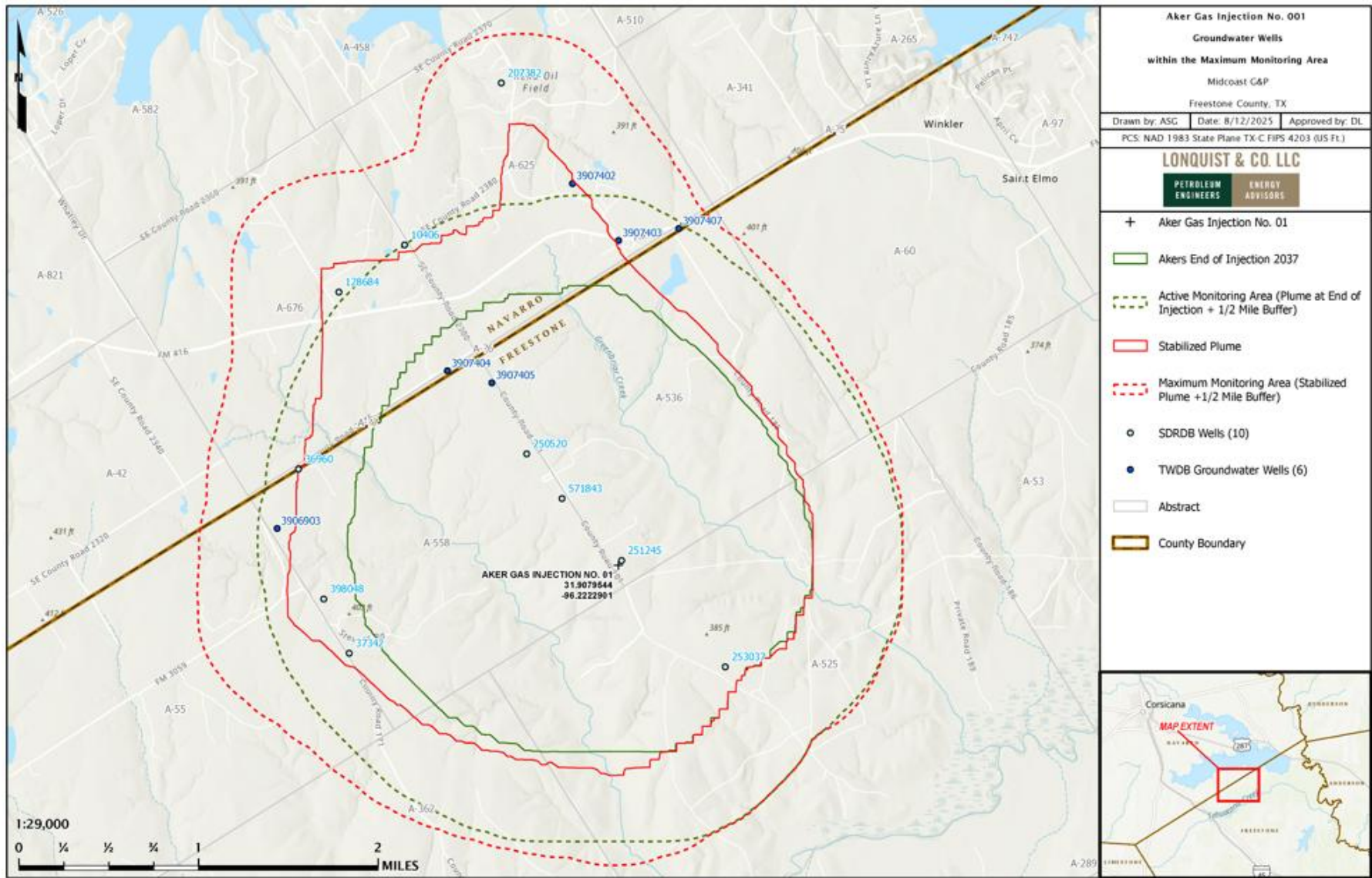

Figure 36 – Groundwater Wells within the MMA.

4.3 Leakage Through Faults or Fractures

No faults were identified within the confinement or injection zones in the MMA. With more than 10 years of operating history in the area, without incident, Midcoast G&P believes that leakage of CO₂ from the Woodbine Formation to the groundwater wells is unlikely.

4.4 Leakage Through Confining Layers

The Eagle Ford shale, a well-known competent barrier, provides upper confinement for the Woodbine interval, preventing CO₂ leakage. Its regional continuity, high clay content, and effective sealing properties, as detailed in Section 2.8, make it an ideal upper confining layer.

The Maness Shale underlies and confines the Woodbine. It is stratigraphically equivalent to the Eagle Ford Shale in areas where the Woodbine is absent. Similar to the Eagle Ford, the Maness Shale has robust sealing properties that effectively prevent fluid migration or leakage. Due to the competent barriers provided by both the upper and lower confining intervals, Midcoast G&P believes that leakage of CO₂ from the Woodbine formation is unlikely.

4.5 Leakage from Natural or Induced Seismicity

The USGS indicates that the Aker No. 1 site lies in a seismically quiet region of the U.S., as depicted in Figure 37. A review of the Bureau of Economic Geology's (BEG) TexNet catalog and the USGS Advanced National Seismic System websites showed no natural or induced seismic activity within 25 km (15.5 mi) of the Aker No. 1 injection site, as illustrated in Figures 38 and 39, respectively.

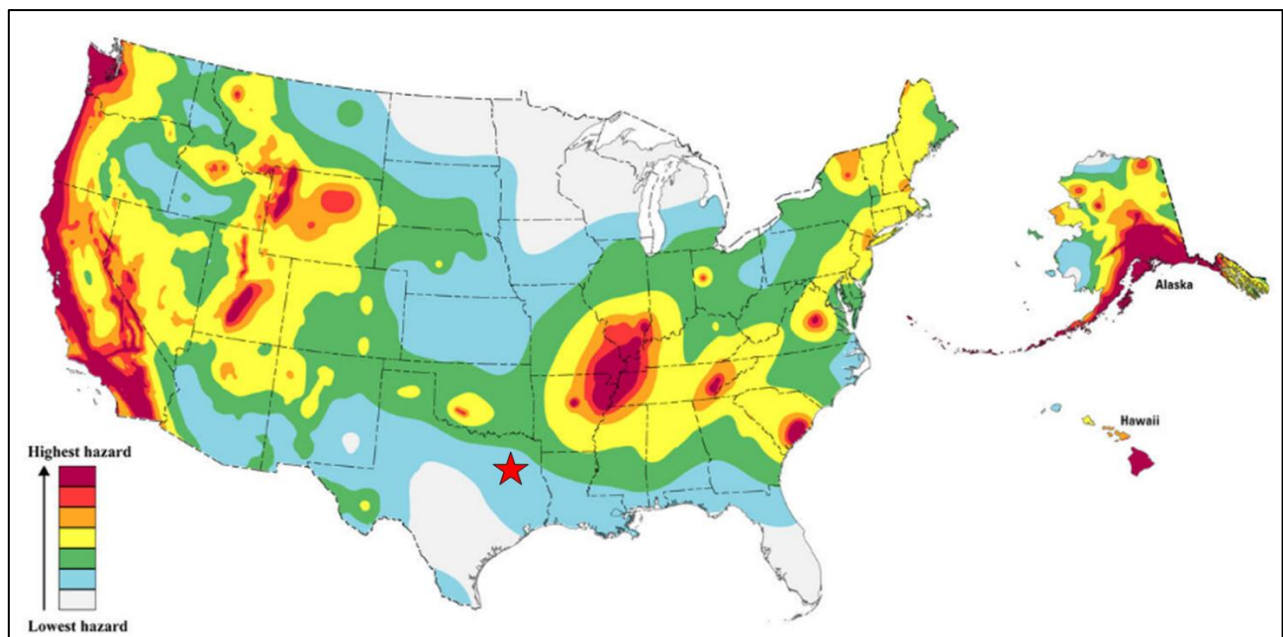

Figure 37 – Hazard map from the 2023 National Seismic Hazard Model Project with the approximate location of Akers No. 1 represented by the red star (modified from USGS, 2023).

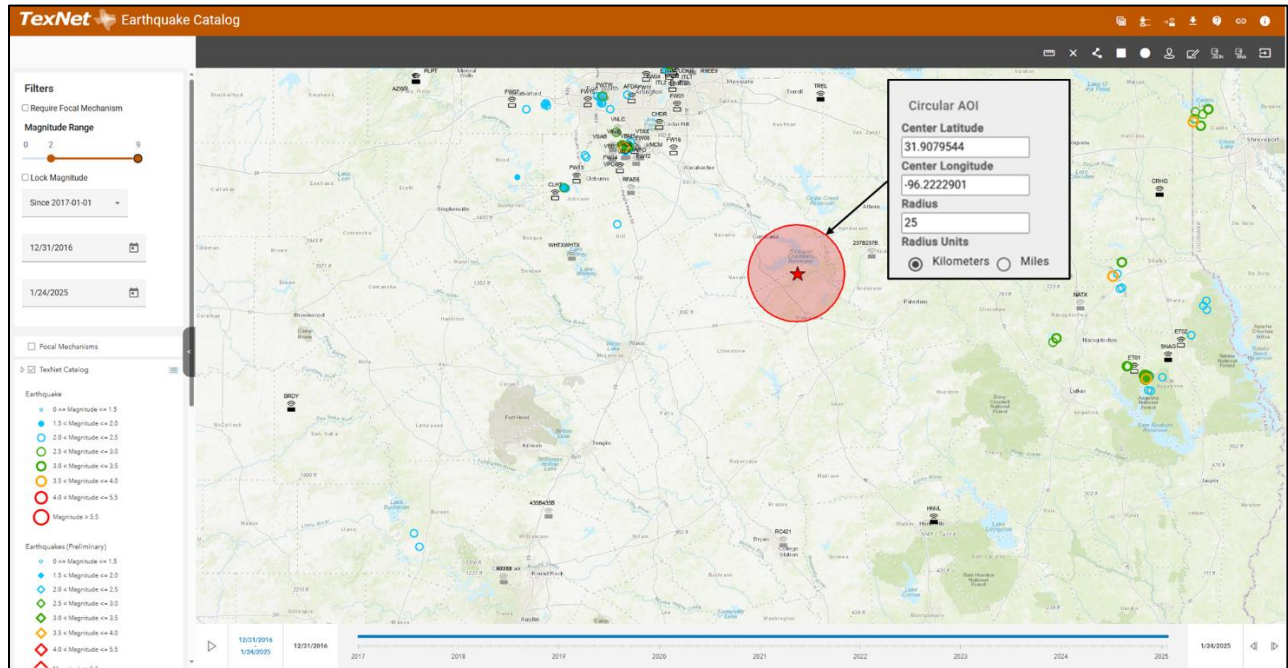

Figure 38 – BEG TexNet Earthquake Catalog query within a 25 km (15.5 mi) radius of the Akers No. 1 location shown by the red star. The query returned zero (0) earthquakes within the queried radius.

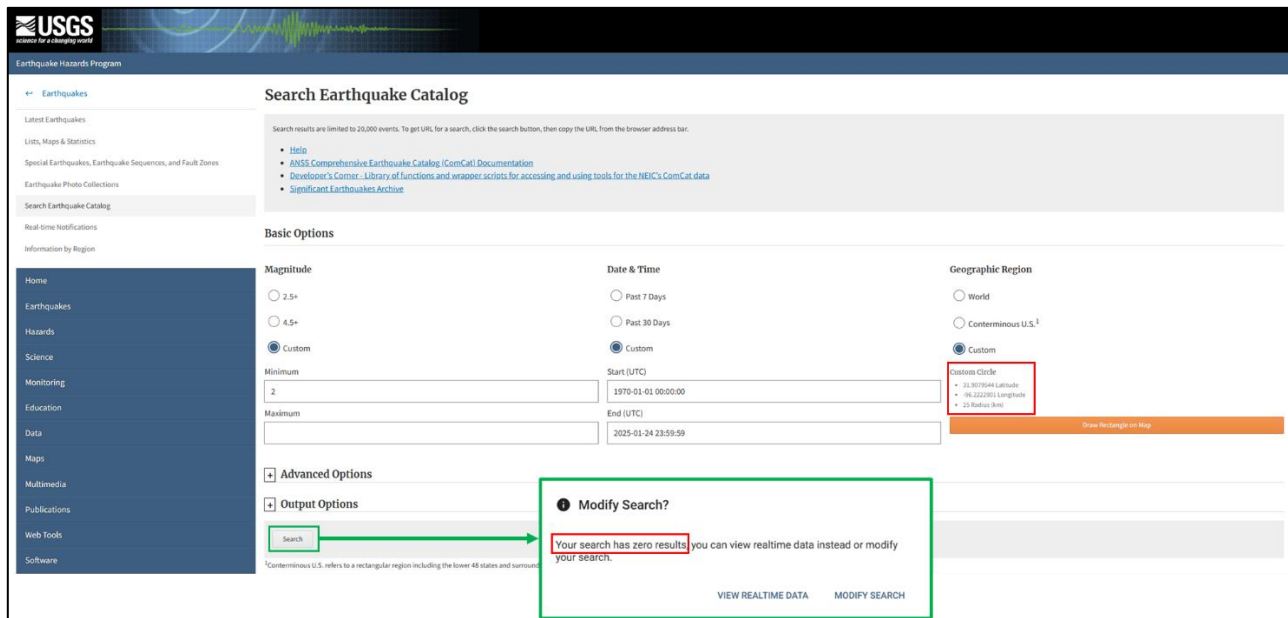

Figure 39 – USGS Earthquake Catalog query within a 25 km (15.5 mi) radius of the Akers No. 1 location which returned zero (0) earthquakes within the queried radius.

Although the well is outside the area of review, a search was conducted using a 100 km (62.1 mi) radius in the USGS database to return the closest recorded seismic events for reference purposes

only. Figure 40 shows the queried results. The closest occurrence was 83 km (51.6 mi) west-northwest from the Akers No. 1 injection site. Therefore, it is concluded that the Akers No. 1 injection operations have not yielded any observable seismic events in the past, nor would ongoing operations be expected to induce any seismicity events.

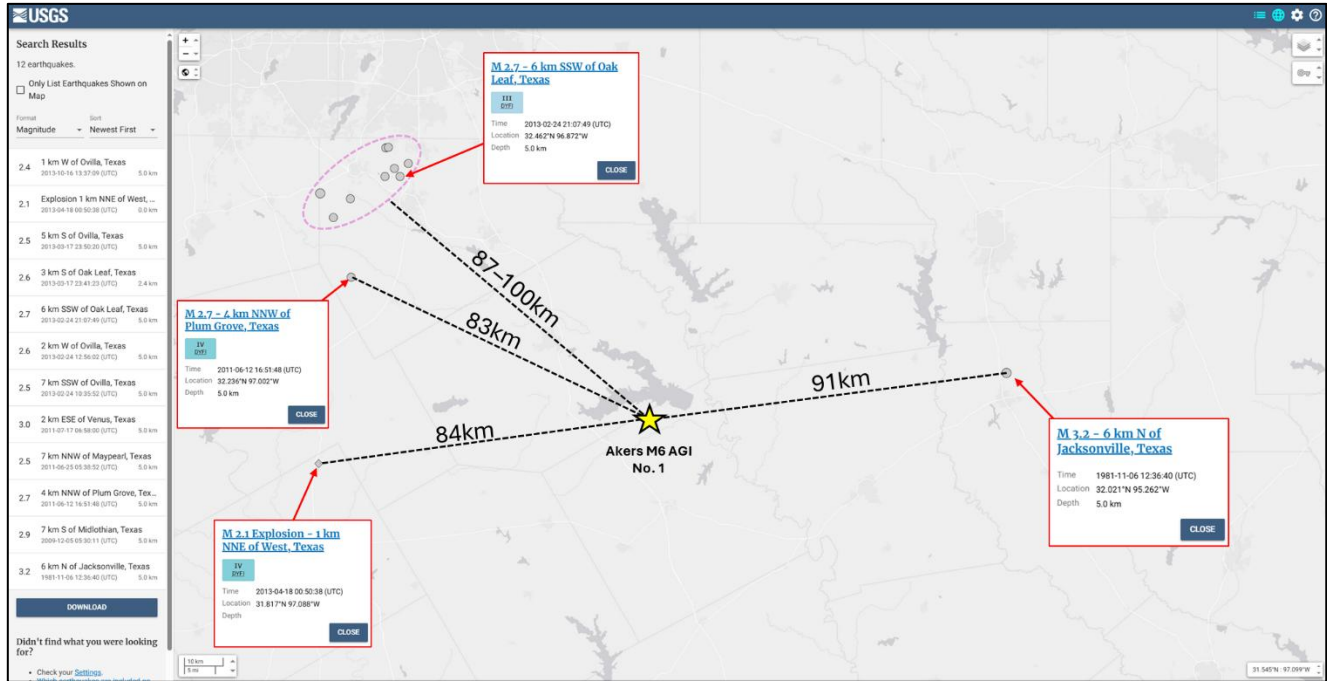

Figure 40 – USGS Earthquake Catalog query within a 100 km (62.1 mi) radius of the Akers No. 1 location to identify the closest recorded seismic event(s). These occurrences are all well outside of the MMA and are only shown for informative purposes.

SECTION 5 – MONITORING FOR LEAKAGE

This section discusses the monitoring strategy Midcoast G&P has designed in compliance with 40 CFR §98.448(a)(3). The strategy will be utilized to detect and quantify surface leakage of carbon dioxide through the pathways detailed in *Section 4*. The leakage pathways and monitoring methods are summarized in Table 13. This section discusses the strategy that Midcoast G&P has designed to meet the requirements of 40 CFR §98.448(a)(3) for detecting and quantifying surface leakage of CO₂ through the pathways identified in Section 4. As the injectate stream contains both H₂S and CO₂, the H₂S will be a proxy for CO₂ leakage; therefore, the monitoring systems in place to detect H₂S will also indicate the release of CO₂. Monitoring will occur during the planned 12-year injection period or cessation of injection operations, plus a proposed 25-year post-injection period until the plume has stabilized.

- Leakage from surface equipment
- Leakage through existing and future wells within the MMA
- Leakage through faults, fractures
- Leakage through the upper confining zone
- Leakage through natural or induced seismicity

Table 13 – Summary of Leakage Monitoring Methods.

Leakage Pathway	Monitoring Method	Frequency
Surface Equipment	Fixed H ₂ S monitors throughout the Aker Plant and Aker No. 1 well	Continuous
	Visual inspections	Daily
	SCADA continuous monitoring of the Aker Plant and Aker No. 1 well	Continuous
Existing Wells	SCADA Continuous Monitoring at the Aker No. 1 well	Continuous
	Mechanical Integrity Test of the Aker No. 1 well	Annually
	Visual Inspections	As needed
	Annual soil gas sampling at well locations within the MMA	Annually
Drilling through MMA	Compliance with TRRC regulations	During operations
	Monitor Drilling Activity	During operations

Faults and Fractures	SCADA Monitoring at the Aker No. 1 well (volumes and pressures)	Continuous
Upper Confining Zone	SCADA Monitoring at the Aker No. 1 well (volumes and pressures)	Continuous
Natural or induced seismicity	Seismic monitoring station	Continuous

5.1 Leakage from Surface Equipment

The Aker Plant and Aker No. 1 are designed and constructed to inject CO₂ and H₂S according to industry best practices and standards to minimize potential leakage points. Critical areas within the facility are constructed with materials that are National Association of Corrosion Engineers (NACE) and American Petroleum Institute (API) compliant. The Aker Plant operations are monitored and controlled with Distributed Control Systems (DCS) and Supervisory Control and Data Acquisition (SCADA) systems providing 24/7 operational supervision. Baseline atmospheric H₂S/CO₂ concentrations are to be established prior to commencing injection volumes reported under this MRV plan. Ambient H₂S detectors are located throughout the Aker Plant and near the Aker No. 1 well with local alarms. They are connected to the SCADA system for continuous monitoring.

Field personnel are to conduct routine inspections of detectors, gauges, and leak indicators, such as vapor plumes and ice formations. The internal and external corrosion control programs are to be monitored for effectiveness by way of periodic inspection of surface equipment, analysis of liquids collected directly from the piping, and cathodic protection system inspections.

Safety systems are to include emergency shutdown (ESD) valves that can isolate segments of the facility and the Aker No. 1 wellhead. A pressure relief valve is installed in the piping to prevent an overpressure event. The Aker Plant is equipped with a flare stack to allow for piping and equipment to be vented or depressurized under safe and controlled operating conditions. In addition, the fixed in-field H₂S-specific devices have a high (Hi) alarm setpoint at 10 ppm and a Hi-Hi setpoint at 20 ppm. In the event of an alarm, personnel are trained to follow the H₂S Contingency Plan for safety and operational matters. Subsequent actions are to be taken to secure the facility and mitigate potential leaks. A safety plot plan for the Aker Plant is provided, as shown in Figures 41 and 42, and is included in Appendix B.

Pressures, temperatures, and flow rates through the surface equipment are continuously monitored during operations. If a release occurred from surface equipment, the amount of CO₂ released is to be quantified based on the operating conditions, including pressure, flow rate, percentage of CO₂ in the acid gas stream, the size of the leak-point opening, and duration of the leak. In the unlikely event a leak occurs, Midcoast G&P will quantify the leak in accordance with the strategies discussed in *Section 7* and in accordance with 40 CFR **§98.448(a)(5)** and **§98.444(d)**.

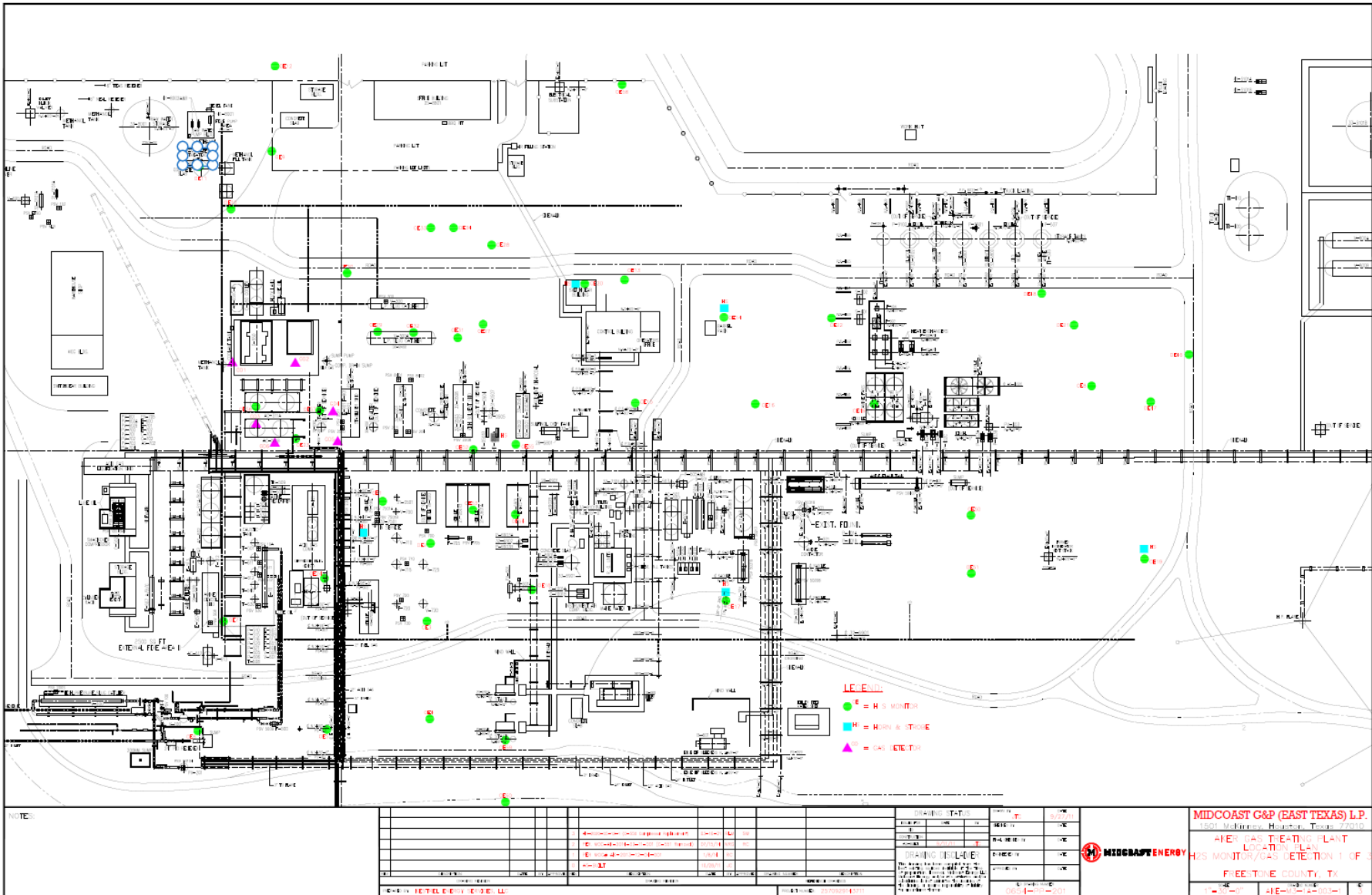

Figure 41 – Aker No. 1 Monitoring and Safety Equipment.

5.2 Leakage from Existing Wells Within MMA

Midcoast G&P will continuously monitor and collect injection volumes, pressures, and temperatures through their SCADA systems for the Aker No. 1 well. This data will be reviewed by qualified personnel and will follow response and reporting procedures when the data is outside of the normal operating range. A change of injection or annular pressure would indicate the presence of a possible leak and would be thoroughly investigated. In addition, an MIT (H-5) will be performed annually as required by Permit Amendment 13099. An unsuccessful MIT would indicate the potential of a leak. Upon an unsuccessful MIT, the well would be isolated, the circumstance would be investigated, and the leak would be mitigated.

In addition to the fixed monitors described previously, Midcoast G&P will establish and operate an in-field monitoring program to detect CO₂ leakage within the MMA. This program would include H₂S monitoring as a proxy for CO₂ at the Aker No. 1 wellsite and annual soil gas samples taken near identified wells within the MMA. The samples will be analyzed by a qualified third party and used to establish a monitoring baseline. Baseline samples will be taken by the end of July 2025, and annually thereafter through the injection period and through the post-injection site care period.

5.2.1 Aker No. 1 Injection Well

The Aker No. 1 was designed and constructed to prevent the migration of CO₂ from the injection interval to the surface. The casing strings for the proposed Aker No. 1 well were designed in accordance with the GAU letter issued for this site and applicable TRRC regulations to safeguard shallow freshwater aquifers and USDWs. The well construction contains premium materials. The well design is illustrated in Figure 43. The likelihood of leakage from the Aker No. 1 injection well is low.

Statewide Rule (SWR) **§3.46** [40 CFR **§146.23 (b)(3)**] requires mechanical integrity tests (MITs) to be run every 5 years to confirm that the well and wellhead can safely hold the appropriate amount of pressure. Under Permit Amendment 13099, Midcoast G&P has agreed to perform an annual MIT on the Aker No. 1. Should the Aker No. 1 fail an MIT, the well would be removed from service and isolated. A root cause analysis would be performed to determine the source of the leak and promptly be repaired to mitigate leakage. Monitoring equipment will be installed in the well, including traditional surface-pressure monitoring on the tubing, casing, and surface casing.

Midcoast G&P will ensure the continuous monitoring and collection of data, including injection volume, temperature, pressure, and gas composition data for the Aker No. 1. The data will be recorded via SCADA systems and reviewed by qualified personnel who will respond according to designated response and reporting procedures if set performance limits are exceeded. A temperature and pressure gauge will be placed at the wellhead in the injection stream, and a pressure gauge will be placed on the casing annulus. Changes in annular pressure would signal the presence of a possible leak.

The Aker No. 1 wellsite will be equipped with a volumetric flow meter, ESD valve, and gas monitors as illustrated in Figures 43 and 44.

5.2.2 Leakage from Oil and Gas Wells in the MMA

There are 35 oil and gas wells within the MMA outline as depicted in Figure 44, of which 27 of these wells penetrate the upper confining zone (UCZ). The remaining 8 wells were either too shallow to penetrate the UCZ or had expired permits or were never drilled. Midcoast G&P operates two observation wells within the injection plume that are completed in the Woodbine Formation. These wells are noted on the map by the red circles. Midcoast G&P will monitor these two observation wells for wellhead pressure and any irregularities. Additionally, Midcoast G&P will perform baseline and annual soil gas monitoring around select penetrators of the UCZ within the MMA.

5.2.3 Leakage Through Groundwater Wells Within MMA

Midcoast G&P will perform baseline and annual groundwater sampling from well No. 3907403 in the northern portion of the stabilized plume, as seen in Figure 36. These water samples will be analyzed by a third-party laboratory for key constituents specific to the acid gas stream, such as CO₂, H₂S, pH, temperature, and other standard laboratory measurements. Any significant variances found in future samples will be evaluated to identify the possible leakage of CO₂.

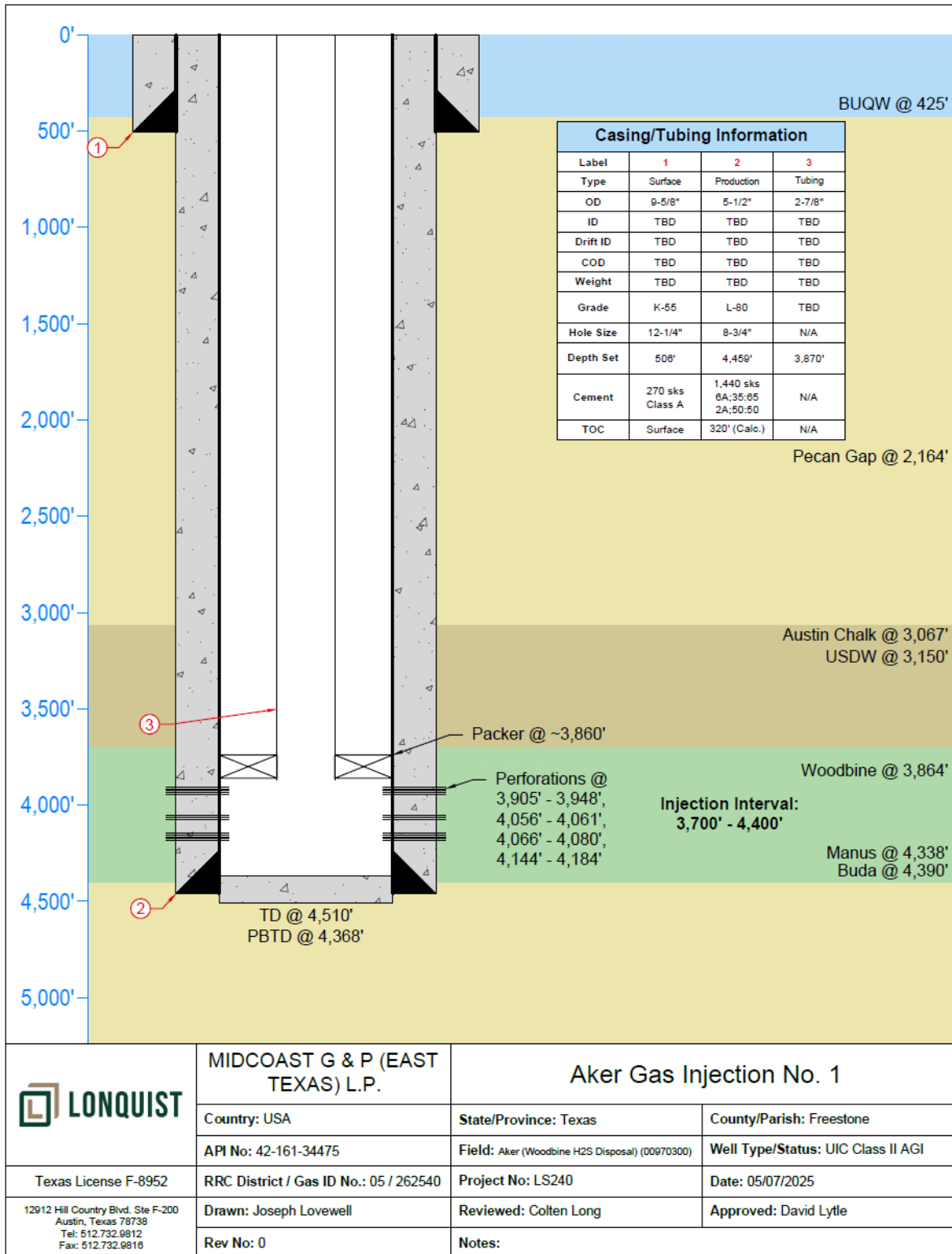

Figure 43 – Aker No. 1 Wellbore Schematic.

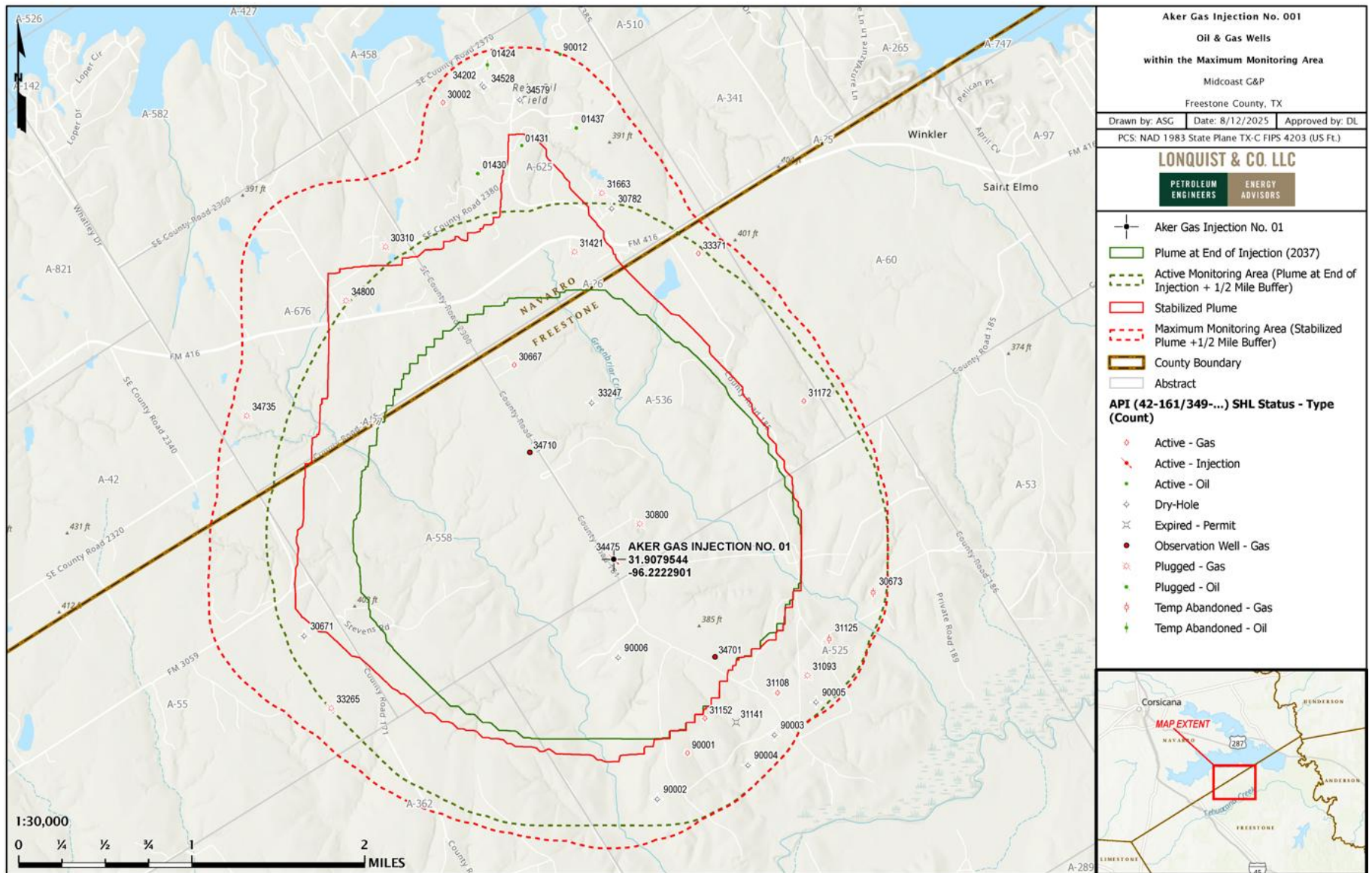

Figure 44 – Oil and Gas Wells Within the MMA.

5.2.4 Leakage from Future Wells within MMA

Midcoast G&P will routinely monitor the TRRC site for permits and drilling activities in the MMA, and for operators' compliance with TRRC SWR Rule 13 (Casing, Cementing, Drilling, Well Control, and Completion Requirements), 16 TAC §3.13. Operators in Freestone and Navarro Counties and Districts 5 and 6, where the Aker No. 1 is located, must comply with TRCC SWR Rule 13, which requires that oil and gas operators set steel casing and cement the well as follows:

- Above and across all formations permitted for injection under TRRC Rule 9
- Immediately above all formations permitted for injection under TRRC Rule 46 for any proposed well within a $\frac{3}{4}$ mi radius of an injection well

SWR Rule 13 also requires operators to case and cement both above and across all potential flow zones and zones containing corrosive formation fluids, which makes the likelihood of leakage from possible new wells low.

5.3 Leakage Through Faults, Fractures, or Confining Zones

Midcoast G&P is operating and will continue to operate Aker No. 1 at injection pressures below the permit limits approved by the TRRC, thereby minimizing the potential for induced seismicity. Midcoast G&P will use its SCADA systems to monitor these operating set points. If these limits are exceeded, alerts are to be triggered to note the operating events. Field personnel will review the data associated with the alert and determine if there has been a risk to the confining seal of the sequestering formation and will take prudent actions as necessary based on the findings.

The data reviewed in *Section 4 – Potential Pathways for Leakage* suggests there is a very low likelihood of potential for leakage through faults, fractures, or the confining layers at the Aker No. 1 location. The upper confining (Eagle Ford Shale) and lower confining (Maness Shale) zones exhibit low permeability and are of sufficient thickness and lateral continuity to serve as complete fluid flow barriers. No faulting was identified in the area by way of subsurface interpretation or white paper research, thus making leakage through faults unlikely.

5.4 Leakage Through Natural or Induced Seismicity

The BEG has established a seismic monitoring network (TexNet) to monitor seismic activity within the State of Texas. Currently, one TexNet monitoring station (No. 237B) exists approximately 40 km east-northeast of the Aker No. 1, as shown in Figure 45. Midcoast G&P will monitor the TexNet and USGS earthquake catalogs. If a seismic event of 2.0 magnitude or greater is detected, Midcoast G&P will investigate the injection volumes and pressures by way of continuous monitoring systems at the Aker No. 1, to determine if any significant changes occurred that would indicate potential leakage. The data reviewed in *Section 4.5* suggests seismicity will not pose a risk of CO₂ migration to the surface in the surrounding MMA around this location, as the nearest seismic activity was recorded

83 km away. The Aker No. 1 is in a relatively inactive portion of the United States from a regional seismic perspective.

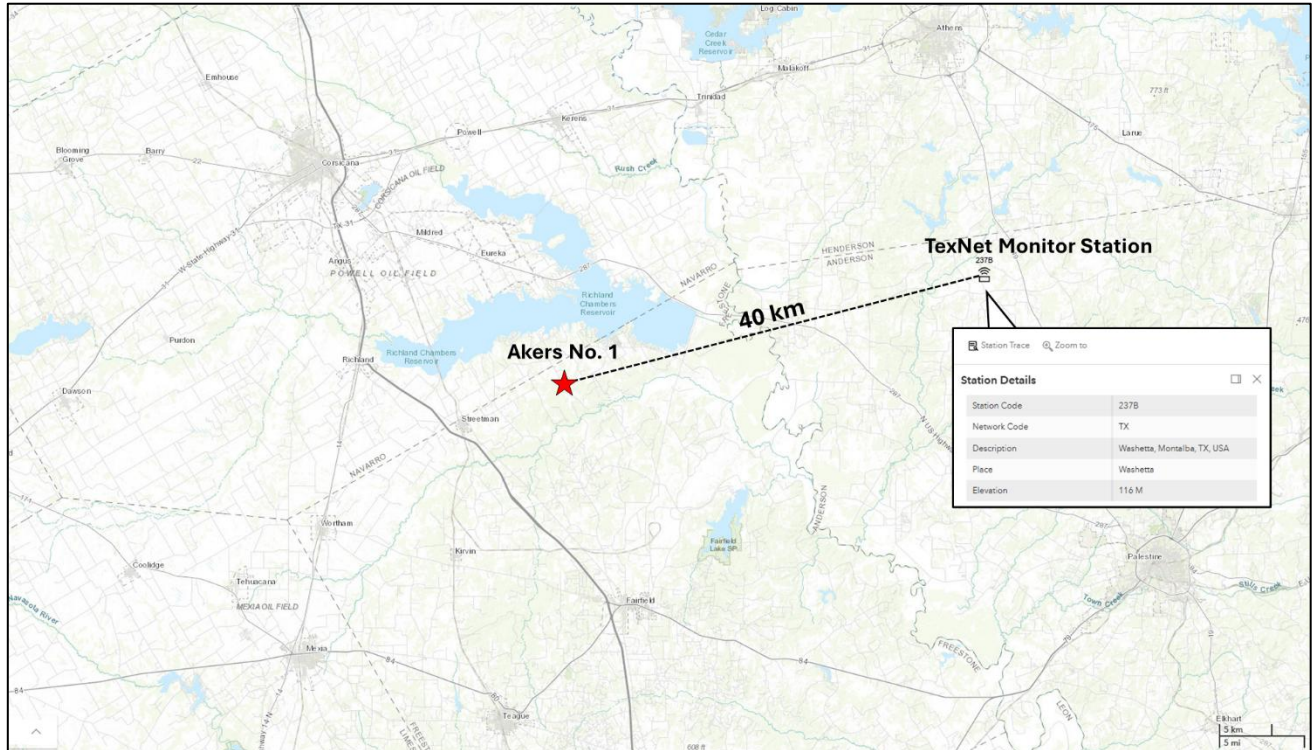

Figure 45 – Map showing nearest TexNet monitoring station No. 237B, located 40 km east-northeast of Akers No. 1.

SECTION 6 – BASELINE DETERMINATIONS

This section identifies the strategies Midcoast G&P will undertake to establish the expected baselines for monitoring CO₂ surface leakage in accordance with 40 CFR §98.448(a)(4). Midcoast G&P will use its SCADA system to identify changes from the expected baseline performance that may indicate leakage and quantify the corresponding amounts of CO₂.

6.1 Visual Inspections

Regular inspections are to be conducted by field personnel at the Aker Plant, the Aker No. 1, and the Aker monitoring wells. These inspections are to aid in identifying and addressing possible issues to minimize the risk of leakage. If any issues are identified, corrective actions are to be taken in accordance with the H₂S Contingency Plan's safety practices.

6.2 CO₂/H₂S Detection

Because of the presence of H₂S in the acid gas stream with the CO₂, Midcoast G&P has an H₂S Contingency Plan in place as is required by the TRRC to monitor for releases. The H₂S detection is used as a proxy for identifying the release of CO₂. Midcoast G&P has installed H₂S monitors throughout the facility, as discussed in Section 5.1.

In addition to the H₂S monitors, Midcoast G&P will establish and operate a soil gas monitoring program to detect leakage of CO₂ within the MMA. Soil gas samples will be collected from select artificial penetration locations within the MMA and analyzed by a third-party laboratory to establish baseline values. The soil gas sampling will be performed annually thereafter.

6.3 Operational Data

Midcoast G&P will record various pressure measurements relating to the Aker No. 1 well before starting injection under this MRV plan. These could include wellhead, annular, and bottom hole pressures, for example. These recorded pressures will establish baseline measurements for reference to future operating pressures. Any significant deviations over time will be analyzed for indication of leakage of acid gas and the corresponding component quantities of CO₂.

6.4 Continuous Monitoring

The total mass of CO₂ emitted by surface leakage and equipment leaks will not be measured directly, as the injection stream for this project is well beyond the Occupational Safety and Health Administration (OSHA) Permissible Exposure Limit (PEL) 8-hour Time Weighted Average (TWA) of 5,000 ppm. Direct leak surveys are dangerous and present a hazard to personnel because of the presence of H₂S in the gas stream. Continuous monitoring systems are designed to trigger an alarm if there is a release. The mass of the CO₂ released would be calculated based on the operating conditions, including pressure, flow rate, percentage of CO₂, size of the leak-point

opening, and duration. This method is consistent with 40 CFR **§98.448(a)(5) and §98.444(d)**, allowing the operator to calculate site-specific variables used in the mass balance equation.

In the case of an operational event, the acid gas stream will be diverted to a flare stack to be safely processed and vented. The event will be documented and reported as required by the TRRC and EPA.

6.5 Groundwater Monitoring

Midcoast G&P will perform baseline and annual groundwater sampling from well No. 3907403 in the northern portion of the stabilized plume. This location is updip of the Aker No. 1 and is in an advantageous position to provide an early indication, should any CO₂ migrate from the Woodbine formation into shallow surface water zones. A third-party laboratory will be used to analyze the samples and establish the baseline properties of the groundwater. The parameters to be measured will include pH, total dissolved solids, total inorganic and organic carbons, density, temperature, and other standard laboratory measurements. Any significant variances found in future annual samples will be evaluated for possible leakage of CO₂.

SECTION 7 – SITE-SPECIFIC CONSIDERATIONS FOR MASS BALANCE EQUATION

This section presents the calculation methods Midcoast G&P will employ to determine the mass of CO₂ injected, emitted, and sequestered. Site-specific variables for calculating CO₂ emissions from equipment leaks and vented emissions of CO₂ between the injection well and injection volumetric flow meter, in accordance with 40 CFR §98.448(a)(5), are also stated.

7.1 Mass of CO₂ Received

40 CFR §98.443 requires the mass of CO₂ received to be calculated using the specified CO₂ received equations “unless you follow the procedures in 40 CFR §98.444(a)(4).” According to 40 CFR §98.444(a)(4), “if the CO₂ you receive is wholly injected and is not mixed with any other supply of CO₂, you may report the annual mass of CO₂ injected that you determined following the requirements under paragraph (b) of this section as the total annual mass of CO₂ received instead of using Equation RR-1 or RR-2 of this subpart to calculate CO₂ received.” The CO₂ received for the Aker No. 1 well is to be wholly injected and not combined with any other supply source; the annual mass of CO₂ injected is to be equal to the amount received. Any additional future streams are to be separately metered before being combined into the calculated injection stream.

7.2 Mass of CO₂ Injected

In accordance with 40 CFR §98.444(b), because a volumetric flow meter is to be used to measure the flow rate of CO₂ injected, the total annual mass of CO₂ in metric tons is to be calculated by multiplying the volumetric flow at standard conditions by the CO₂ concentration in the flow and the density of CO₂ at standard conditions according to Equation RR-5:

$$CO_{2,u} = \sum_{p=1}^4 Q_{p,u} * D * C_{CO_2,p,u}$$

Where:

CO_{2,u} = Annual CO₂ mass injected (metric tons) as measured by flow meter u.

Q_{p,u} = Quarterly volumetric flow rate measurement for flow meter u in quarter p at standard conditions (standard cubic meters per quarter).

D = Density of CO₂ at standard conditions (metric tons per standard cubic meter):
0.0018682

C_{CO₂,p,u} = CO₂ concentration measurement in flow for flow meter u in quarter p (vol. percent CO₂, expressed as a decimal fraction).

p = Quarter of the year

u = Flow meter

7.3 Mass of CO₂ Produced

The Aker Plant only processes hydrocarbons and associated CO₂ from deeper formations such as the Sligo and Cotton Valley. There is no production from the Woodbine Formation, where the CO₂ is injected. As such, no CO₂ will be produced from these injection facilities.

7.4 Mass of CO₂ Emitted by Surface Leakage and Equipment Leaks

The mass of CO₂ emitted by surface leakage will not be measured directly due to the presence of H₂S in the injection stream and the safety risk that direct leak surveys present for personnel. Because no venting is expected to occur, the calculations would be based on an unusual blowdown event, with those gas volumes being sent to a flare stack and reported as part of the Aker Plant's reporting requirements. Any leakage would be detected and managed as an upset event. SCADA continuous monitoring systems would trigger an alarm upon a release of H₂S and CO₂. The mass of the CO₂ released would be calculated based on the operating conditions, including pressure, flow rate, size of the leak-point opening, and duration of the leak. This method is consistent with 40 CFR §98.448(a)(5) and allows the operator to calculate site-specific variables used in the mass balance equation.

In the unlikely event CO₂ is released due to a surface leak, the mass emitted would be calculated for each surface pathway according to methods outlined in the plan and totaled using Equation RR-10 as follows:

$$CO_{2E} = \sum_{x=1}^X CO_{2,x}$$

Where:

CO_{2E} = Total annual CO₂ mass emitted by surface leakage (metric tons) in the reporting year

CO_{2,x} = Annual CO₂ mass emitted (metric tons) at leakage pathway x in the reporting year

X = Leakage pathway

Calculation methods from Subpart W will be used to calculate CO₂ emissions from equipment located on the surface between the volumetric flow meter and the Aker No. 1 wellhead, and these emissions will be included in the term CO_{2FI} of equation RR-12.

Midcoast G&P believes the potential pathways for all previously mentioned forms of leakage are unlikely. Given the possibility of uncertainty around the cause of a leakage pathway, Midcoast G&P believes the most appropriate method to quantify the mass of CO₂ released will be determined on a case-by-case assessment of the circumstances. Any mass of CO₂ detected leaking to the surface

will be quantified by using industry-proven engineering methods, including but not limited to engineering analysis on surface and subsurface measurement data, dynamic reservoir modeling, and history-matching of the sequestering reservoir performance. In the unlikely event a leak occurs, it will be addressed, quantified, and documented within the appropriate timeline. Any records of leakage events will be kept and stored as stated in *Section 10*.

7.5 Mass of CO₂ Sequestered

Midcoast G&P plans to begin injections in the third quarter of 2025, at which time data collection will begin for calculating sequestered amounts. The mass of CO₂ sequestered will be calculated based on Equation RR-12. When injection operations commence, Midcoast G&P will begin collecting data for reporting under this plan based on the approval of this MRV plan and any applicable stipulations therein. The calculation of sequestered volumes will utilize the following equation because these wells will not actively produce oil, natural gas, or any other fluids:

$$CO_2 = CO_{2I} - CO_{2E} - CO_{2FI}$$

Where:

CO₂ = Total annual CO₂ mass sequestered in subsurface geologic formations (metric tons) at the facility in the reporting year

CO_{2I} = Total annual CO₂ mass injected (metric tons) in the well or group of wells covered by this source category in the reporting year

CO_{2E} = Total annual CO₂ mass emitted (metric tons) by surface leakage in the reporting year

CO_{2FI} = Total annual CO₂ mass emitted (metric tons) from equipment leaks and vented emissions of CO₂ from equipment located on the surface between the flow meter used to measure injection quantity and the injection wellhead, for which a calculation procedure is provided in subpart W of this part.

Because no venting will occur, the calculations would be made in case of an unusual event in which a blowdown is required. Those emissions sent to flares would be reported as part of the required GHGRP for the gas plant.

Equations from Subpart W – Petroleum and Natural Gas Systems **§98.232** will be used to calculate CO₂ emissions from equipment located on the surface between the flow meter used to measure injection quantities and the injection wellhead.

7.6 Mass of CO₂ Emitted Due to Leaks Other Than Surface Equipment

Given the uncertainty of sources other than surface equipment that may create leakage pathways, Midcoast G&P will quantify the mass of CO₂ released based on specific parameters at the time of

release. Any mass of CO₂ detected leaking to the surface will be quantified by using industry-proven methods such as engineering analysis of surface and subsurface measurement data, dynamic reservoir modeling, and history-matching of the sequestering reservoir performance. In the rare event a leak occurs, it will be addressed, quantified, and documented within an appropriate timeline. Records of leakage events will be kept and retained as stated in *Section 10*.

SECTION 8 – IMPLEMENTATION SCHEDULE FOR MRV PLAN

The Aker No. 1 well is also subject to reporting injected volumes and pressures under the TRRC Class II regulations. Midcoast G&P is submitting this MRV application to the GHGRP to comply with the requirements of Subpart RR. The MRV plan is to be implemented upon receiving EPA approval. The Annual Subpart RR Report is to be filed on March 31 of the year following the reporting year.

Midcoast G&P completed the baseline surveys, as discussed in Section 6, in July 2025. The analysis and results of these baseline surveys are still in process.

Midcoast G&P is currently injecting into the Aker No. 1 and recording injection data. Upon approval of this MRV plan by the GHGRP, MidCoast G&P will immediately track the data as required by 40 CFR **§98.448(a)(7)**.

SECTION 9 – QUALITY ASSURANCE

Midcoast G&P plans to manage quality assurance and quality control (QA/QC) under the requirements of 40 CFR **§98.444**, using the methods identified in this section.

9.1 Monitoring Quality Assurance and Quality Control

CO₂ Injected

- The flow rate of the acid gas being injected is to be measured with a volumetric flow meter, consistent with applicable industry standards in accordance with 40 CFR **§98.448**. These flow rates will be compiled quarterly.
- The composition of the acid gas stream will be measured downstream of the amine unit with either a continuous gas chromatograph or sampled regularly and analyzed by a qualified lab consistent with industry best practices. The analysis of the acid gas will be used with the volumetric flow meter data to calculate the volume of CO₂ in the acid gas stream.
- The composition of the measured acid gas stream will be averaged quarterly.
- The acid gas measurement equipment will be calibrated in accordance with the requirements of 40 CFR **§98.444(e)** and **98.3(i)** of the GHGRP in conjunction with manufacturer recommendations.

CO₂ Emissions from Leaks and Vented Emissions

- Gas monitors will be operated continuously, except for maintenance and calibration.
- Gas monitors will be calibrated according to manufacturer recommendations and the requirements of 40 CFR **§98.444(e)** and **98.3(i)**.
- Calculation methods using equations from Subpart W will be used to calculate CO₂ emissions due to any surface leakage between the volumetric flow meter used to measure injection quantities and the Aker No. 1 well.

Measurement Devices

- The flow meter will be continuously operated except for maintenance and calibration.
- The flow meter will be calibrated according to the requirements in 40 CFR **§98.3(i)**.
- The flow meter will be operated and maintained in accordance with applicable industry standards, as published by a consensus-based standards organization.

All quantities of CO₂ will be converted to standard cubic meters at an absolute pressure of 1 atmosphere and a temperature of 60°F.

9.2 Missing Data

In accordance with 40 CFR **§98.445**, Midcoast G&P will use the following procedures to estimate missing data if the data needed for the mass balance calculations was not collected:

- If a quarterly quantity of CO₂ injected is missing, the amount will be estimated using a representative quantity of CO₂ injected from the nearest previous period at a similar injection pressure.
- Fugitive CO₂ emissions from surface equipment leaks will be estimated and reported per the procedures specified in Subpart W of 40 CFR §98.

9.3 MRV Plan Revisions

If any changes outlined in 40 CFR §98.448(d) occur, Midcoast G&P will revise and submit an amended MRV plan to the Administrator for approval within 180 days. At least 180 days before the end of the initial 5 years of active injection, an amended MRV plan will be submitted for this facility with an updated plume extent based on measured conditions in the wells. At that time, the extent of the AMA and MMA will be revised.

SECTION 10 – RECORDS RETENTION

In adherence to the requirements of 40 CFR §98.3(g), Midcoast G&P will retain records for at least 3 years and include the following:

- Quarterly records of the CO₂ injected
 - Volumetric flow rates at standard conditions
 - Volumetric flow rates at operating conditions
 - Operating temperature and pressure
 - Concentration of the acid gas stream (CO₂, H₂S, and other) stream
- Annual records of the information used to calculate the CO₂ emitted by surface leakage from leakage pathways.
- Annual records of information used to calculate CO₂ emitted from equipment leaks and from equipment located on the surface between the gas meter used to measure injection quantity at the Aker Plant, and the injection volumetric flow meter at the Aker Well No. 1 wellhead.

REFERENCES

- Ambrose, W. A., Hentz, T. F., Bonnaffe, F. and others (2009). Sequence-stratigraphic controls on complex reservoir architecture of highstand fluvial-dominated deltaic and lowstand valley-fill deposits in the Upper Cretaceous (Cenomanian) Woodbine Group, East Texas field: Regional and local perspectives. *AAPG Bulletin*, Vol. 93, No. 2, p. 231-269.
- Bruun, B., Jackson, K., and Lake, P. (2016). Texas Aquifers Study: Groundwater Quantity, Quality, Flow, and Contributions to Surface Water. *KIP Articles*, No. 4891.
- Calavan, C. W. (1985). Depositional environments and basinal setting of the Cretaceous Woodbine Sandstone, Northeast Texas. *AAPG Bulletin*, Vol. 69, No. 1, 125 pp.
- Dawson, W. C. (1997). Limestone microfacies and sequence stratigraphy: Eagle Ford Group (Cenomanian-Turonian) north-central Texas outcrops. *Gulf Coast Association of Geological Societies Transactions*, Vol. 47, p. 99-105.
- Dawson, W. C., and Almon, W. R. (2010). Eagle Ford Shale Variability: Sedimentologic Influences on Source and Reservoir Character in an Unconventional Resource Unit. *Gulf Coast Association of Geological Societies Transactions*, Vol. 60, p. 181-190.
- Dennen, K.O., and Hackley, P.C. (2012). USGS Publications Warehouse: Definition of Greater Gulf Basin Lower Cretaceous and Upper Cretaceous Lower Cenomanian Shale Gas Assessment Unit, United States Gulf of Mexico basin onshore and state waters. <https://pubs.usgs.gov/publication/70176229>
- Dolton, G. L., Carlson, K. H., Charpentier, R. R., and others (1981). Estimates of Undiscovered Recoverable Conventional Resources of Oil and Gas in the United States. U.S. Geological Survey, Geological Circular 860, 87 pp.
- Ewing, T. E. (2009). The ups and downs of the Sabine Uplift and the northern Gulf of Mexico Basin: Jurassic basement blocks, Cretaceous thermal uplifts, and Cenozoic flexure. *GCAGS Transactions*, Vol. 59, p. 253-269.
- Foote, R. Q., Massingill, L. M., and Wells, R. H. (1988). Petroleum geology and the distribution of conventional crude oil, natural gas liquids, East Texas basin. U.S. Geological Survey, DOI Report 88-450K, 118 pp.
- Galloway, W.E. (2008). Sedimentary Basins of the World: Chapter 15, Depositional Evolution of the Gulf of Mexico Sedimentary Basin, Vol. 5: 505-549. [http://dx.doi.org/10.1016/S1874-5997\(08\)00015-4](http://dx.doi.org/10.1016/S1874-5997(08)00015-4)

- Hentz, T. F., and Ruppel, S. C. (2011). Regional Stratigraphic and Rock Characteristics of Eagle Ford Shale in Its Play Area: Maverick Basin to East Texas Basin. AAPG Search and Discovery Article #10325
- Hentz, T. F., Ambrose, W. A., and Smith, D. C. (2014). Eaglebine play of the southwestern East Texas basin: Stratigraphic and depositional framework of the Upper Cretaceous (Cenomanian-Turonian) Woodbine and Eagle Ford Groups. *AAPG Bulletin*, Vol. 98, No. 12, p. 2551-2580.
- Holtz, M. H., Nance, P. K., and Finley, R. J. (1999). Reduction of Greenhouse Gas Emissions through Underground CO₂ Sequestration in Texas Oil and Gas Reservoirs. The University of Texas at Austin, Bureau of Economic Geology, Final Report, 82 pp.
- Hovorka, S. D. (1999). Optimal Geological Environments for Carbon Dioxide Disposal in Saline Aquifers in the United States. Bureau of Economic Geology, The University of Texas at Austin.
- Jackson, M. P. A. (1982). Fault Tectonics of the East Texas Basin. Bureau of Economic Geology, The University of Texas at Austin, Geological Circular 82-4, 31 pp.
- Jackson, M. P. A., and Seni, S. J. (1984). Atlas of salt domes in the East Texas basin. Bureau of Economic Geology, The University of Texas at Austin Report of Investigation No. 140, 102 pp.
- Loucks, R. G., Reed, R. M., Ambrose, W. A. (2015). Analysis of Pore Networks and Reservoir Quality of the Upper Cretaceous Woodbine Sandstone in the High-Recovery-Efficiency, Giant East Texas Field. *GCAGS Journal*, Vol. 4, p. 88-108.
- Meyer, M. J., Donovan, A. D., and Pope, M. C. (2021). Depositional environment and source rock quality of the Woodbine and Eagle Ford Groups, southern East Texas (Brazos) Basin: An integrated geochemical, sequence stratigraphic, and petrographic approach. *AAPG Bulletin*, Vol. 105, No. 4, p. 809-843.
- Patterson, S., and Denne, R. (2019). The Maness Shale: A Comparison of the Geomechanical and Mineralogic Properties within the Lower Eagle Ford Near the San Marcos Arch. *AAPG Datapages, Search and Discovery Article No. 11240*.
- Przywara, M., Howard, A., Hernandez, R., and Brooks, D. (2011). Unconventional Reservoir Evaluation: Focus on the Eagle Ford. *Gulf Coast Association of Geological Societies Transactions*, Vol. 61, p. 625-629.
- Ramiro-Ramirez, S., Sonnenberg, S. A., and Santi, P. (2016). Petrographic and Petrophysical Characterization of the Eagle Ford Shale in La Salle and Gonzales Counties, Gulf Coast Region, Texas. *Colorado School of Mines, 2016 Thesis Paper*.
- Swanson, S.M., Enomoto, C.B., Dennen, K.O. et al. (2016). Geologic assessment of undiscovered oil and gas resources—Lower Cretaceous Albian to Upper Cretaceous Cenomanian carbonate

rocks of the Fredericksburg and Washita Groups, United States Gulf of Mexico Coastal Plain and State Waters: U.S. Geological Survey Open-File Report 2016–1199, 69 pp. <https://doi.org/10.3133/ofr20161199>

Wescott, W. A., and Hood, W. C. (1994). Hydrocarbon generation and migration routes in the East Texas Basin. *AAPG Bulletin*, Vol. 78, p. 287-307.

Yurewicz, D.A., Marler, T.B., Meyerholtz, K.A., and Siroky, F.X. (1993). Early Cretaceous Carbonate Platform, North Rim of the Gulf of Mexico, Mississippi and Louisiana, Chapter 8 of Cretaceous Carbonate Platforms. *AAPG Memoir* 56, J. A. Toni Simo, Robert W. Scott, Jean-Pierre Masse, 81-96. <https://doi.org/10.1306/M56578C8>

APPENDICES

APPENDIX A – GEOLOGY

APPENDIX A-1: Figure 1– Cross section X-X' through the Aker Monitor Well No. 1, the Aker No. 1, and the Aker Monitor Well No. 2, from left to right, respectively.

APPENDIX A-1: Figure 11 – Cross section X-X' through the Aker Monitor Well No. 1, the Aker No. 1, and the Aker Monitor Well No. 2, from left to right, respectively.

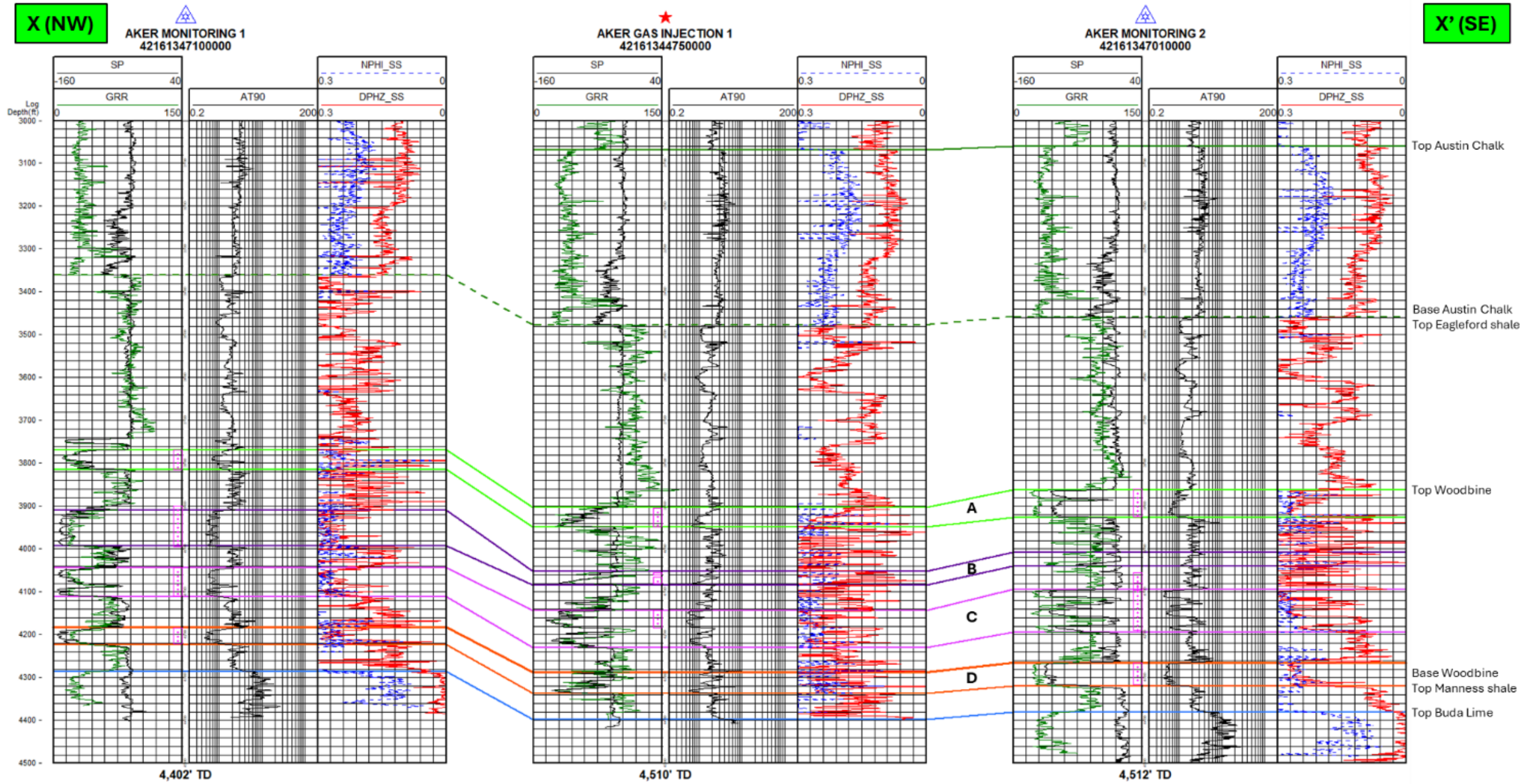

APPENDIX B – FACILITIES

APPENDIX B-1 – FACILITY SAFETY PLOT PLAN

APPENDIX B-1: FACILITY SAFETY PLOT PLAN

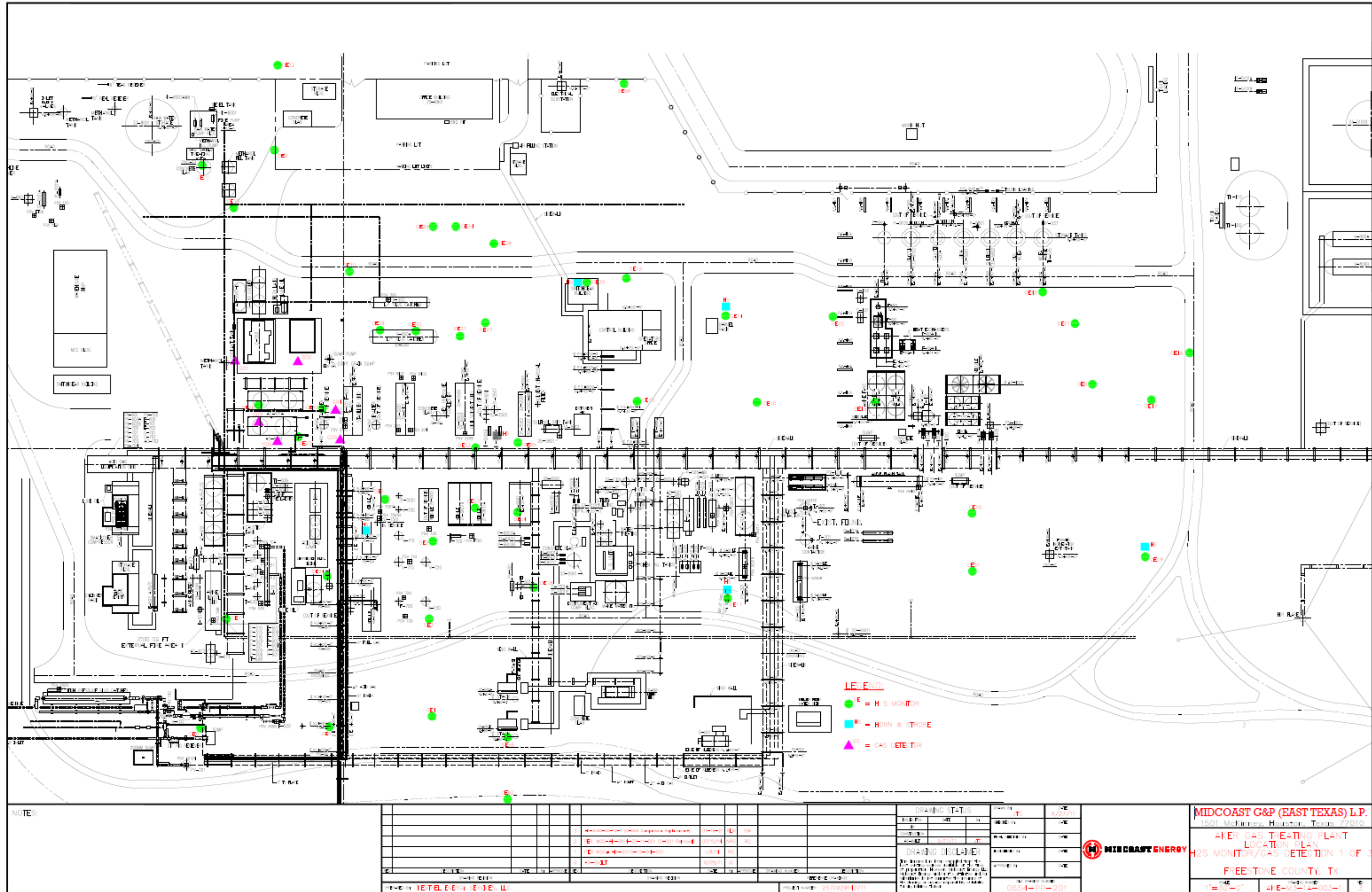

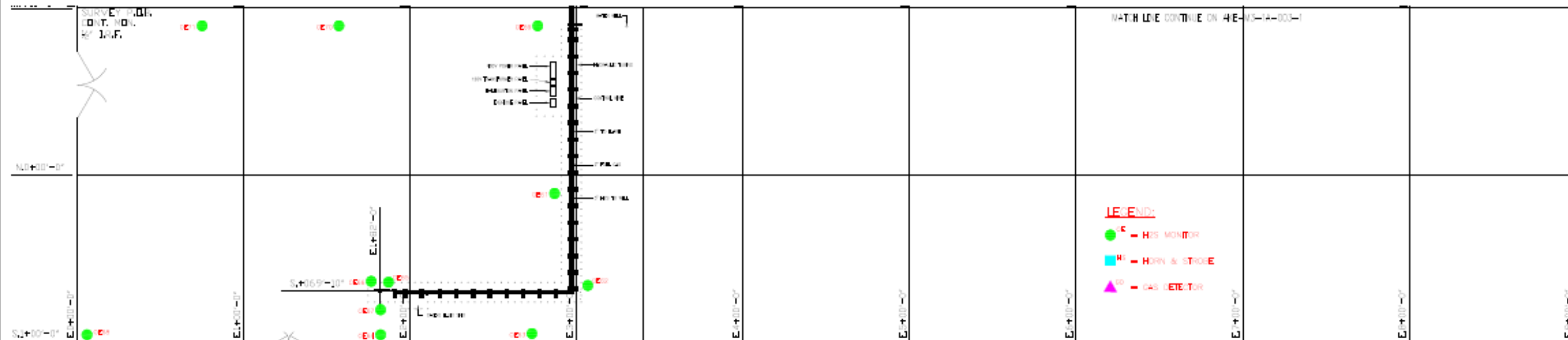
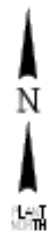

NOTES:

DATE	DESCRIPTION	BY	CHECKED

DRAWING STATUS: **REVISED** TO: 5/20/11
 DRAWING NUMBER: 4E-14-003-1
 DRAWING TITLE: H2S MONITOR/GAS DETECTION 3 OF 3
 PROJECT: MIDCOAST G&P (EAST TEXAS) L.P.
 1501 McMurree Highway, Houston, Texas 77010
HORN & STROKE ENERGY
 FREESTONE COUNTY, TX
 SHEET: 4E-14-003-1

APPENDIX C – MMA AOR REVIEW MAPS

APPENDIX C-1: Maximum Monitoring Area Map

APPENDIX C-2: Oil and Gas Wells Within the MMA Map

APPENDIX C-3: Oil and Gas Wells Within the MMA List

APPENDIX C-4: Groundwater Wells Within the MMA Map

APPENDIX C-5: Groundwater Wells Within MMA List

APPENDIX C-1: Maximum Monitoring Area Map

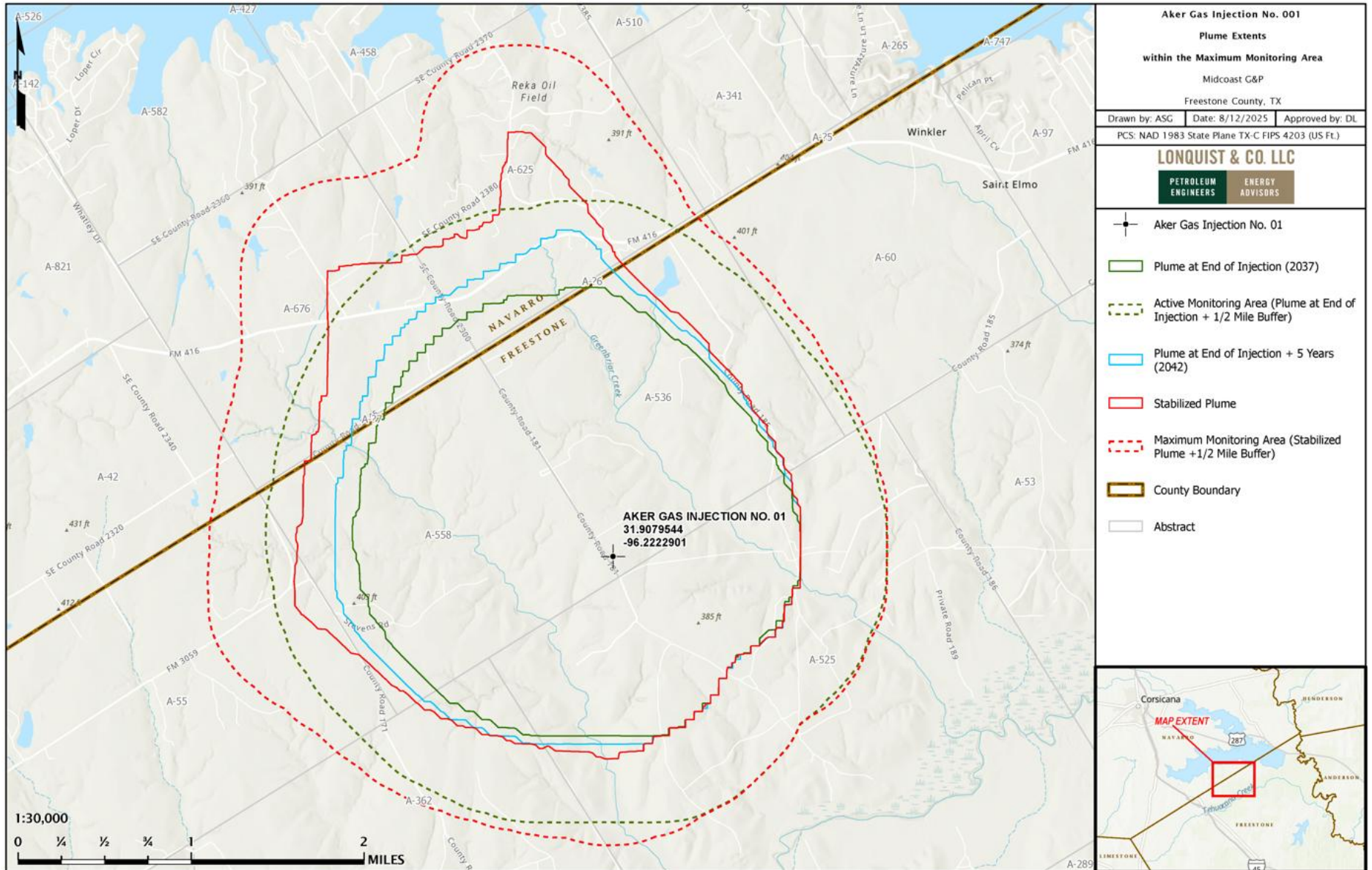

APPENDIX C-2: Oil and Gas Wells Within the MMA Map

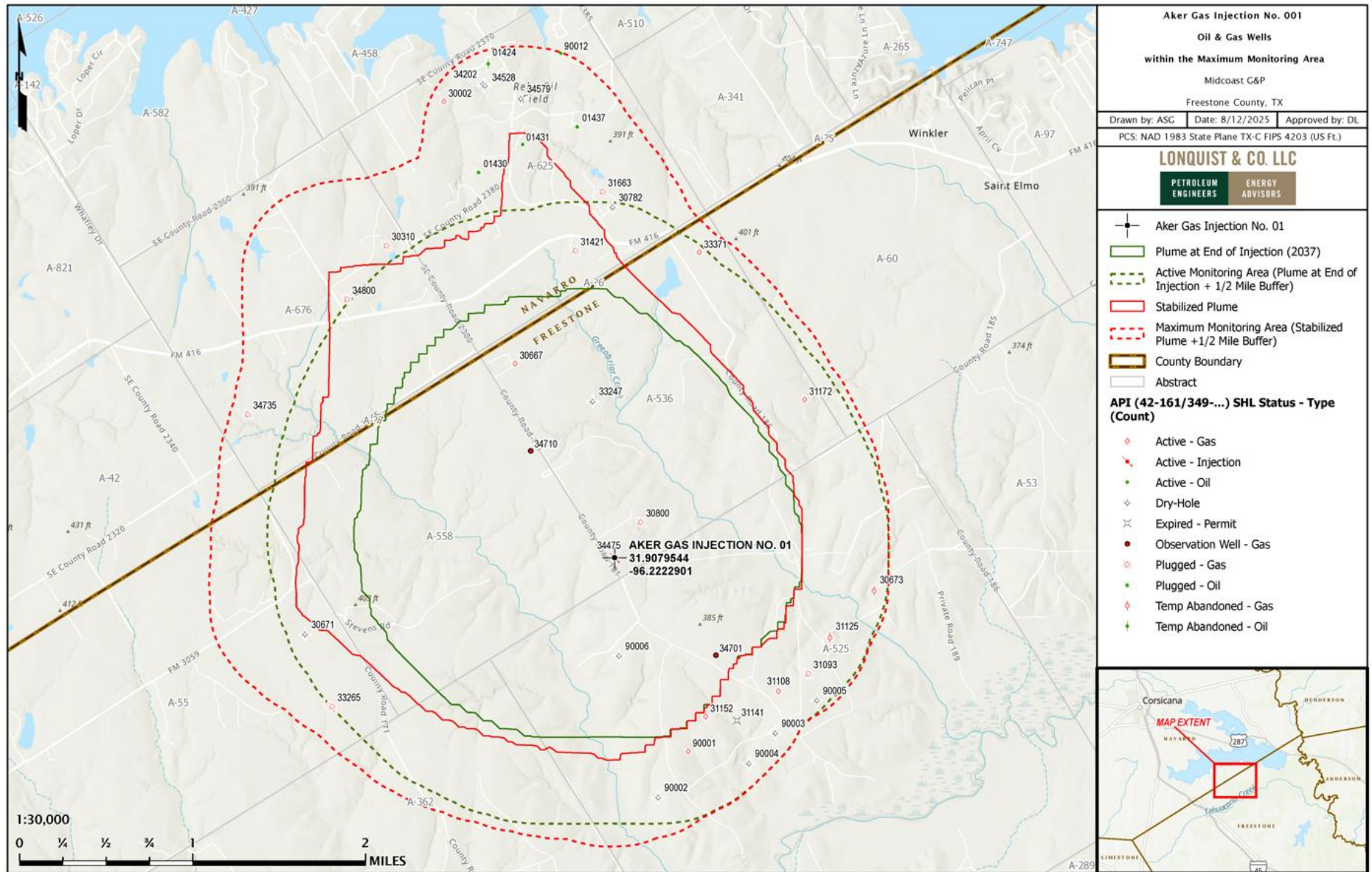

APPENDIX C-3: Oil and Gas Wells Within the MMA List

Aker Gas Injection No. 001

Area of Review: Penetrator List

API	WELL NAME	WELL NO.	CURRENT OPERATOR	ABSTRACT	LATITUDE (WGS84)	LONGITUDE (WGS84)	WELL STATUS	TOTAL DEPTH (FT.)	PERFORATED INTERVAL (FT.)	DATE DRILLED
4216130667	MCCONNICO, CORA ESTATE	1	REO OPERATING LLC	536	31.924561	-96.23136	Active - Gas	11770	11361-11672	7/28/1981
4216130671	ROBINSON, RUTH	1	AMERICAN PETROFINA CO. OF TEX.	55	31.902499	-96.252978	Dry-Hole	12346	6569-6581	9/4/1981
4216130673	FERGUSON, J. R. ESTATE	1	HRB OPERATING COMPANY, INC.	525	31.9043780	-96.1969340	Temp Abandoned - Gas	12200	2004-2014	8/10/1981
4216130800	AKER PLANT SWD	1	KOCH MIDSTREAM SERVICES CO LLC	536	31.910868	-96.219589	Plugged - Gas	4250	4190-4208	7/12/1983
4216131093	MUMBERSON ET AL	1	FAULCONER, VERNON E., INC.	525	31.897643	-96.203675	Plugged - Gas	10867	10738-10793	4/28/1989
4216131108	MUMBERSON ET AL	2	FAULCONER ENERGY, LLC	525	31.8962780	-96.2066710	Active - Gas	10966	10871-10893	10/31/1989
4216131125	FERGUSON, J. R. ESTATE	2	HRB OPERATING COMPANY, INC.	525	31.900609	-96.20143	Temp Abandoned - Gas	11000	10172-10200	6/5/1990
4216131141	MUMBERSON, ETAL	3	GOODRICH OIL COMPANY	525	31.89393	-96.210864	Expired - Permit	10950	0-0	-
4216131152	MUMBERSON ET AL	3	FAULCONER ENERGY, LLC	525	31.8943690	-96.2139070	Active - Gas	11039	10940-10948	2/4/1991
4216131172	HOWELL-ANDERSON	1	OLD UNION OPERATING COMPANY	536	31.9206260	-96.2030300	Active - Gas	11500	11172-11187	1/26/1992
4216133247	HOWELL, B.D. ET. AL.	1	REDMAN OPERATING COMPANY	536	31.9211470	-96.2238700	Dry-Hole	11350	0-0	7/20/2005
4216133265	ROBINSON HEIRS GAS UNIT	1	XTO ENERGY INC.	55	31.8963720	-96.2506030	Plugged - Gas	10896	10734-10736	5/30/2006
4216133371	SIMPSON	1	OLD UNION OPERATING COMPANY	536	31.9333110	-96.2128650	Active - Gas	11416	11064-11101	10/29/2005
4216134475	AKER GAS INJECTION	1	MIDCOAST G & P (EAST TEXAS) L.P.	536	31.9079540	-96.2222900	Active - Injection	4510	3905-4184	4/7/2011
4216134701	AKER MONITORING	2	MIDCOAST G & P (EAST TEXAS) L.P.	525	31.8994810	-96.2126880	Observation Well - Gas	4512	3861-4316	5/15/2011

Aker Gas Injection No. 001

4216134710	AKER MONITORING	1	MIDCOAST G & P (EAST TEXAS) L.P.	558	31.9171870	-96.2301470	Observation Well - Gas	4402	3769-4222	4/22/2011
4234901430	REDWINE, W.L. -A-	1	MILLER, MIKE / MILLER PROD. CO.	625	31.9406950	-96.2342490	Plugged - Oil	7342	7098-7306	-
4234930002	ANDERSON GAS UNIT	1	OLD UNION OPERATING COMPANY	625	31.9467510	-96.2374210	Active - Gas	12020	10196-10206	3/2/1969
4234930310	BEAUCHAMP, H. D. UNIT #1	1	KAISER-FRANCIS OIL COMPANY	676	31.9348490	-96.2435940	Plugged - Gas	10704	10318-10579	8/31/1975
4234930782	ANDERSON	1	UNIVERSAL RESOURCES CORP.	625	31.9373460	-96.2212050	Dry-Hole	10800	0-0	9/25/1978
4234931421	ANDERSON, JOE E.	1	MIDCOAST G & P (EAST TEXAS) L.P.	625	31.9338440	-96.2250260	Plugged - Gas	11784	11203-11460	11/22/1980
4234931663	ANDERSON, JOE E.	2	BROOKS PIPE & SUPPLY CO.	625	31.9386940	-96.2221380	Plugged - Gas	11841	11423-11710	3/11/1981
4234934202	ANDERSON GAS UNIT "B"	1	AMOCO PRODUCTION COMPANY	625	31.9480980	-96.2334790	Dry-Hole	11481	0-0	6/16/1988
4234934528	ANDERSON G/U	1	KEY PRODUCTION COMPANY, INC.	625	31.9479390	-96.2333400	Dry-Hole	7387	6827-7294	10/2/1995
4234934579	TROEGEL	1	SKLAR & PHILLIPS OIL CO.	625	31.9467500	-96.2298330	Dry-Hole	9730	0-0	2/26/1998
4234934735	SCAMMEL GAS UNIT II	1	XTO ENERGY INC.	676	31.9211380	-96.2578140	Plugged - Gas	10730	10491-10647	2/16/2007
4234934800	PORTER GAS UNIT	2	XTO ENERGY INC.	676	31.9304690	-96.2476610	Plugged - Gas	10818	10442-10613	10/17/2007

*Note: Well entries in red penetrate the upper confining layer.

APPENDIX C-4: Groundwater Wells Within the MMA Map

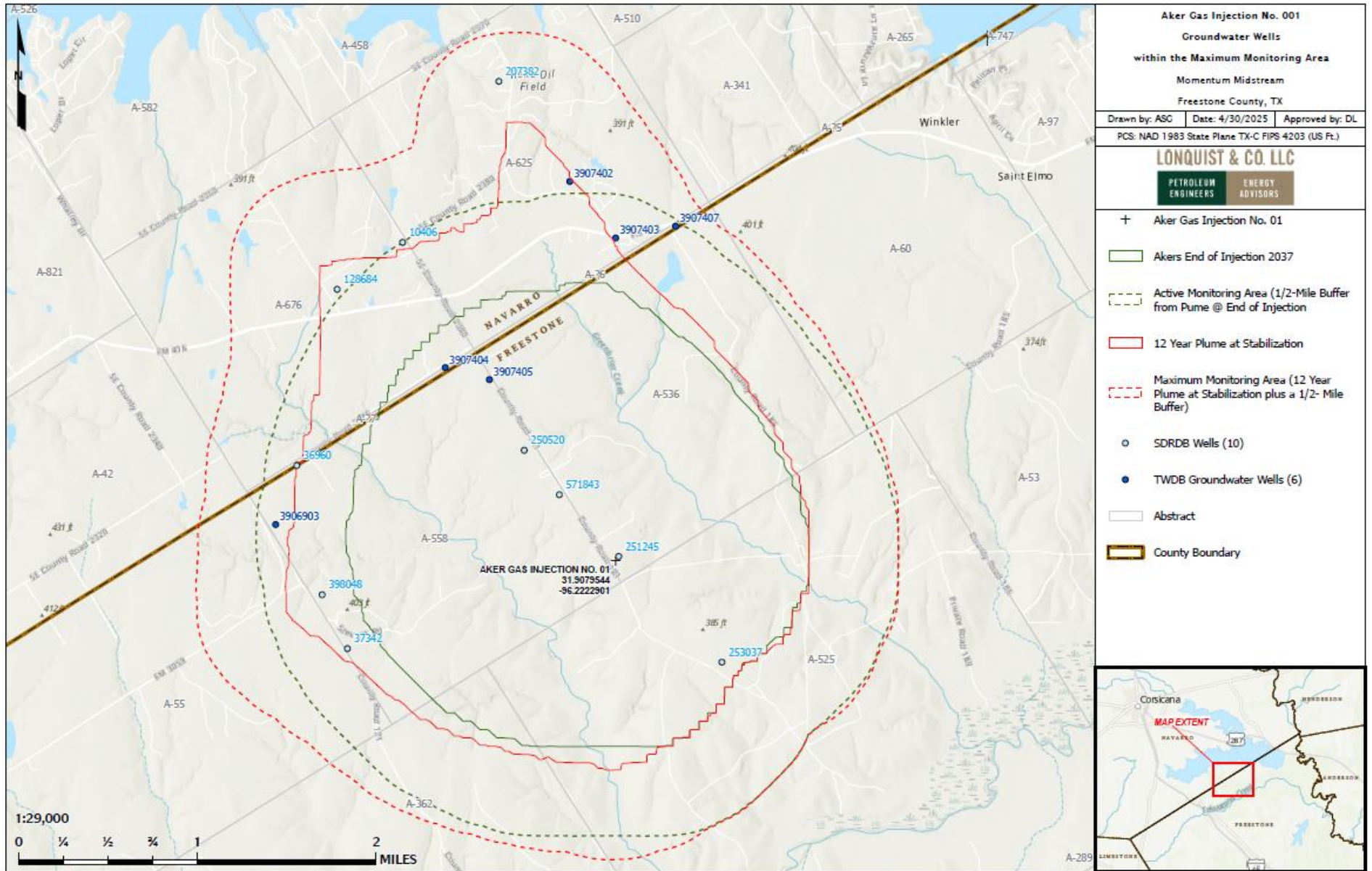

APPENDIX C-5: Groundwater Wells Within MMA List

Akers Gas Injection No. 001
Water Wells within Maximum Monitoring Area

	Well Report	Source	Well Type	Owner's Name	Lat. WGS 84	Lat. WGS 84	Well Use	County	Formation	Total Depth (Ft.)
1	10406	SDRDB	New Well	Neal & Co.	31.934445	-96.241389	Domestic	Navarro	-	63
2	36960	SDRDB	New Well	Justin Robinson	31.916667	-96.252223	Domestic	Freestone	-	61
3	37342	SDRDB	New Well	CHARLIE THOMPSON	31.901667	-96.248056	Domestic	Freestone	-	77
4	128684	SDRDB	New Well	XTO Energy, Inc.	31.930833	-96.247778	Rig Supply	Navarro	-	160
5	207382	SDRDB	New Well	Tina Stokes	31.947222	-96.231667	Irrigation	Freestone	-	53
6	250520	SDRDB	New Well	Enbridge	31.917222	-96.230555	Rig Supply	Freestone	-	140
7	251245	SDRDB	New Well	Enbridge G & P (East Texas) LP	31.908334	-96.221944	Rig Supply	Freestone	-	120
8	253037	SDRDB	New Well	Enbridge	31.899445	-96.212501	Rig Supply	Freestone	-	120
9	398048	SDRDB	New Well	Mark L. Meade	31.906112	-96.250278	Domestic	Navarro	-	120
10	371843	SDRDB	New Well	Brent Morgan	31.913514	-96.22737	Domestic	Freestone	-	135
	Well Report	Source	Well Type	Owner's Name	Lat. WGS 84	Lat. WGS 84	Well Use	County	Formation	Total Depth (Ft.)
1	3906903	TWDB	Withdrawal of Water	Lanelle Clark	31.91194500	-96.25444500	Domestic	Freestone	124WLCK - Wilcox Group	21
2	3907402	TWDB	Withdrawal of Water	-	31.93888900	-96.22527800	Unused	Navarro	124WLCK - Wilcox Group	38
3	3907403	TWDB	Withdrawal of Water	Joe Anderson	31.93416700	-96.22111100	Stock	Navarro	124WLCK - Wilcox Group	53
4	3907404	TWDB	Withdrawal of Water	Joe Anderson	31.92416700	-96.23777800	Stock	Navarro	124WLCK - Wilcox Group	30
5	3907405	TWDB	Withdrawal of Water	B. J. French	31.92305500	-96.23361100	Domestic	Freestone	124WLCK - Wilcox Group	40
6	3907407	TWDB	Withdrawal of Water	Winkler Water Supply Corp.	31.93494170	-96.21537220	Public Supply	Navarro	124WLCK - Wilcox Group	163

**Request for Additional Information: Aker Plant
July 30, 2025**

Instructions: Please enter responses into this table and make corresponding revisions to the MRV Plan as necessary. Any long responses, references, or supplemental information may be attached to the end of the table as an appendix. This table may be uploaded to the Electronic Greenhouse Gas Reporting Tool (e-GGRT) in addition to any MRV Plan resubmissions.

No.	MRV Plan		EPA Questions	Responses
	Section	Page		
1.	Cover	1	Section 1.0 of the MRV plan states that the facility's name is Aker Gas Plant, but the facility's name in e-GGRT is "Aker Plant". We recommend updating either the name in the MRV plan or the name in e-GGRT for consistency.	The MRV plan has been edited to reflect the Aker Plant.
2.	2.0	11-56	Note that there are two sections in the MRV plan titled "Section 2.1". We recommend reordering the subsections in Section 2.0.	Each section is consistently numbered. Only one section, titled 2.1 was found. Perhaps uploading through the e-GGRT caused a technical issue.
3.	2.0	35	<p>"According to X-ray Diffraction (XRD) mineralogy data published by Patterson and Denne (2019), the constituents of the Maness Shale from order of highest occurrence by volume to lowest include clays, silica, carbonate-calcite, feldspar-micas, and pyrite; specific constituent volumes from core samples can be found in Table 7."</p> <p>The order of mineral constituents identified in bold in the statement above from the MRV plan appears to be inconsistent with the order of the mineral constituents presented in Table 7. Please address this inconsistency.</p>	The text and table have been edited for consistency with Patterson and Denne (2019).

No.	MRV Plan		EPA Questions	Responses
	Section	Page		
4.	2.0	37	<p>“No faulting in the area was observed from the local subsurface data, nor were any regional faults found within the AOR from the publicly available structure maps that were reviewed.”</p> <p>Because the monitoring strategies should be based on the MMA, not the AoR, we recommend reviewing the MRV plan to ensure that the different leakage pathways discussed in the plan reflect the entire MMA.</p>	The MRV plan has been reviewed and edited to use consistent acronyms.
5.	2.0	45	<p>“The acid gas injectate is composed of CO₂, H₂S, and trace components of hydrocarbons (C1 – C7), as shown in Table 7.”</p> <p>While the statement above from the MRV plan references Table 7, the description matches the caption for Table 8. Please review the MRV plan to ensure that all references are correct.</p>	The plan has been edited for correct Table references.
6.	3.1	57	<p>Per 40 CFR 98.449, maximum monitoring area is defined as equal to or greater than the area expected to contain the free phase CO₂ plume until the CO₂ plume has stabilized plus an all-around buffer zone of at least one-half mile.</p> <p>While the MRV plan defines the MMA, please provide further explanation of whether the MMA meets the definitions in 40 CFR 98.449. For example, please explain how it was determined that the plume stabilizes after 25 years.</p>	<p>3.1 has been updated to with the following language.</p> <p>Plume stabilization is deemed to have occurred when the rate of growth or positional change of the plume size year over year becomes indiscernible. The stabilization of the plume is determined by the model output, when the areal growth rate drops below 0.25% size per year.</p>

No.	MRV Plan		EPA Questions	Responses
	Section	Page		
7.	3.2	57	<p>Per 40 CFR 98.449, the boundary of the active monitoring area is established by superimposing two areas:</p> <p>(1) The area projected to contain the free phase CO₂ plume at the end of year t, plus an all-around buffer zone of one-half mile or greater if known leakage pathways extend laterally more than one-half mile.</p> <p>(2) The area projected to contain the free phase CO₂ plume at the end of year t + 5.</p> <p>While the MRV plan explains that the MMA will be used as the AMA, please provide further explanation of whether this AMA meets the definitions in 40 CFR 98.449. For example, please specify whether CO₂ plume will remain in the AMA boundaries at year t and year t+5 as required in the above definitions. Does the MMA completely contain the AMA by these definitions?</p>	<p>Clarification to these points has been updated</p> <p>Clarification The application in Section 3 has been updated to clarify the points identified here. These clarifications include</p> <ul style="list-style-type: none"> - t is defined as 12 years - t + 5 = 17 years - Plume stabilization per the model occurs at 25 years after cessation of injection - Figure 32 has been updated to clarify these extents <p>To fully clarify, since the extents of t and t + 5 fall within the 37 year plume extent, and the MMA Extent (37 years + ½ mi.); and the MMA extent is not substantially greater than the AMA, the operator has defined the AMA equal to the MMA</p>
8.	3.2	58	<p>The legend in Figure 32 shows the MMA represented by the “12-year plume at stabilization” plus a one-half mile buffer. We recommend clarifying that the MMA is defined by the stabilized CO₂ plume following the 12-year injection period and 25 years of density drift. Please also review this in Figure 12.</p>	<p>The legends on maps related to this issue have been edited for clarity.</p>
9.	4.0	59	<p>“Leakage through the UCZ”.</p> <p>We recommend revising the header to also include the lower confining zone, since it is discussed in both sections 4.4 and 5.3. Please also review tables 12 and 13 accordingly.</p>	<p>The table was updated for consistency with sections 4.4 and 5.3.</p>

No.	MRV Plan		EPA Questions	Responses
	Section	Page		
10.	4.2	61	<p>“A map of the wells that penetrate the Upper Confinement within the MMA is shown in Figure 35.”</p> <p>Please clarify whether there are additional wells in the area that do not penetrate the Upper Confining Zone, and if so discuss their characteristics (e.g., depth) and potential for leakage in Section 4.</p>	<p>Section 4.2 has been edited to reflect a review of all wells within the MMA. Figure 35 has been updated to depict all oil and gas wells in the MMA.</p>
11.	4.2	61	<p>“In this area, most of the drilling activity targets the Cotton Valley, Bossier, and Rodessa formations, which occur at depths of between 10,000 ft and 11,500 ft; significantly deeper than the Woodbine Formation.”</p> <p>The formations identified in the statement above from the MRV plan were not included in Figure 4. We recommend showing the location of these formations relative to the injection interval in the plan.</p>	<p>Figure 4 has been updated with an (a) and (b) depiction of the stratigraphic column to provide additional detail.</p>
12.	5.0	69	<p>The MRV plan states, “Monitoring is planned until injection operations cease.”</p> <p>However, the MRV plan also states, “Monitoring will occur during the planned 12-year injection period or cessation of injection operations, plus a proposed 25-year post-injection period until the plume has stab.”</p> <p>The statements above from the MRV plan appear to contradict each other. We recommend reviewing the requirements at 40 CRR 98.441(b) and revising the statements above as necessary.</p>	<p>Section 5 has been edited to provide a consistent expectation on monitoring during the injection and post-injection period until the plume has stabilized.</p>

No.	MRV Plan		EPA Questions	Responses
	Section	Page		
13.	5.1	70	<p>“A safety plot plan for the Aker Gas Plant is provided, as shown in Figures 42 and 43, and is included in Appendix B.”</p> <p>While the statement above from the MRV plan references figures 42 and 43, the description matches the captions for figures 43 and 44. Please review all references in the MRV plan.</p>	The Figure references have been edited for consistency.
14.	5.2	73-78	<p>“The likelihood of leakage from the Aker No. 1 injection well is remote.”</p> <p>“SWR Rule 13 also requires operators to case and cement both above and across all potential flow zones and zones containing corrosive formation fluids, which makes the likelihood of leakage from possible new wells remote.”</p> <p>The statements above from the MRV plan characterize the likelihood of leakage through Aker No. 1 as “remote”. However, Table 12 characterizes the likelihood of leakage as “medium”. We recommend reviewing the MRV plan to ensure that the characterizations of the likelihood of leakage are consistent throughout the plan, and/or defining these terms for clarity.</p>	The plan has been edited for consistency. While there are 27 wells penetrating the upper confinement and ongoing drilling activity in the area. Most well locations within the MMA have already been drilled and the requirements of SWR 13 keep the likelihood and magnitude of an event “Low”.
15.			<p>“The Aker Gas Plant is not part of an enhanced oil recovery project; therefore, no CO2 will be produced from the Aker No. 1 well.”</p> <p>Please note that the requirement to calculate CO2 produced is not dependent on whether or not the facility is conducting enhanced oil recovery. See 40 CFR 98.443(d) for more information. In the MRV plan, please clarify whether any injected CO2 might be produced at this facility.</p>	The plan has been edited to clarify that there is no CO2 production from the Woodbine Formation. CO2 at the Aker Plant is only produced from much deeper hydrocarbon bearing formations.

No.	MRV Plan		EPA Questions	Responses
	Section	Page		
16.	7.4	83	<p>“Calculation methods from Subpart W will be used to calculate CO₂ emissions from equipment located on the surface between the volumetric flow meter and the Aker No. 1 wellhead.”</p> <p>The discussion above from the MRV plan occurs in conjunction with the discussion regarding the mass of CO₂ emitted by surface leakage (RR-10). Please note that equipment leaks and vented emissions between the flow meter and the wellhead are not included in equation RR-10, but rather as a separate term in equation RR-12.</p> <p>We recommend revising this statement to reflect this distinction, for example: “Calculation methods from Subpart W will be used to calculate CO₂ emissions from equipment located on the surface between the volumetric flow meter and the Aker No. 1 wellhead, and these emissions will be included in term CO_{2FI} of equation RR-12.”</p>	7.4 has been edited to include “ and these emissions will be included in the term CO _{2FI} of equation RR-12.”
17.	8	85	<p>“The MRV plan is to be implemented upon receiving EPA approval. The Annual Subpart RR Report is to be filed on March 31 of the year following the reporting year. Midcoast G&P will perform the baseline surveys, as discussed in Section 6, by the end of July 2025.”</p> <p>Please clarify whether the MRV plan includes a “proposed date to begin collecting data for calculating total amount sequestered according to equation RR-11 or RR-12 of this subpart” As required by <u>40 CFR 98.448(a)(7)</u>.</p>	The Operator is currently injecting into the Aker No. 1 and recording injection data. Upon approval of this MRV plan by the GHGRP, MidCoast G&P will immediately track the data as required by <u>40 CFR 98.448(a)(7)</u> .
18.	All			Various edits and clarifications throughout the document to further support and clarify the above responses.



**Subpart RR Monitoring, Reporting, and
Verification Plan
Aker No. 1**

Freestone County, Texas

Prepared for Midcoast G&P (East Texas) L.P.
Houston, Texas

By

Lonquist Sequestration, LLC
Austin, Texas

June 2025



INTRODUCTION

Midcoast G&P (East Texas) L.P. (Midcoast G&P) operates an acid gas injection well in the Aker (Woodbine H₂S Disposal) Field. The Aker Gas Injection Well No. 1 (Aker No. 1) API No. 42-161-34475 received its Class II injection permit from the Texas Railroad Commission (TRRC) on June 22, 2010, with a Permit Amendment (Permit No. 13099 Amendment) approved November 15, 2023. The Aker No. 1 has been injecting into the Woodbine Formation since April of 2012.

The Aker No. 1 was developed to dispose of oil and gas waste from its Aker Gas Plant in Freestone County, Texas. Located in a rural agricultural area, the plant is approximately 6.2 miles (mi) Northeast of Streetman, TX (Figure 1). The Aker No. 1 is permitted for 9 million standard cubic feet per day (MMscf/d) of treated acid gas (TAG) from the Aker Gas Plant with a maximum allowable surface injection pressure (MASIP) of 1,800 pounds per square inch gauge (psig).

Midcoast G&P is submitting this Monitoring, Reporting, and Verification (MRV) Plan to the Environmental Protection Agency (EPA) for approval under Title 40, U.S. Code of Federal Regulations (40 CFR) **98.440(a)**, under Subpart RR of the Greenhouse Gas Reporting Program (GHGRP). Midcoast G&P intends to inject into the Aker No. 1 for approximately 12 years at up to a maximum of 9 MMscf/d. The primary source of this injected CO₂ gas is the Aker Gas Plant. Table 1 shows the expected composition of the gas stream to be sequestered.

Table 1 – Expected Gas Composition

Component	Mol Percent
Carbon Dioxide (CO ₂)	98
Hydrogen Sulfide (H ₂ S)	2

Mol – molecular weight of a substance expressed in grams.

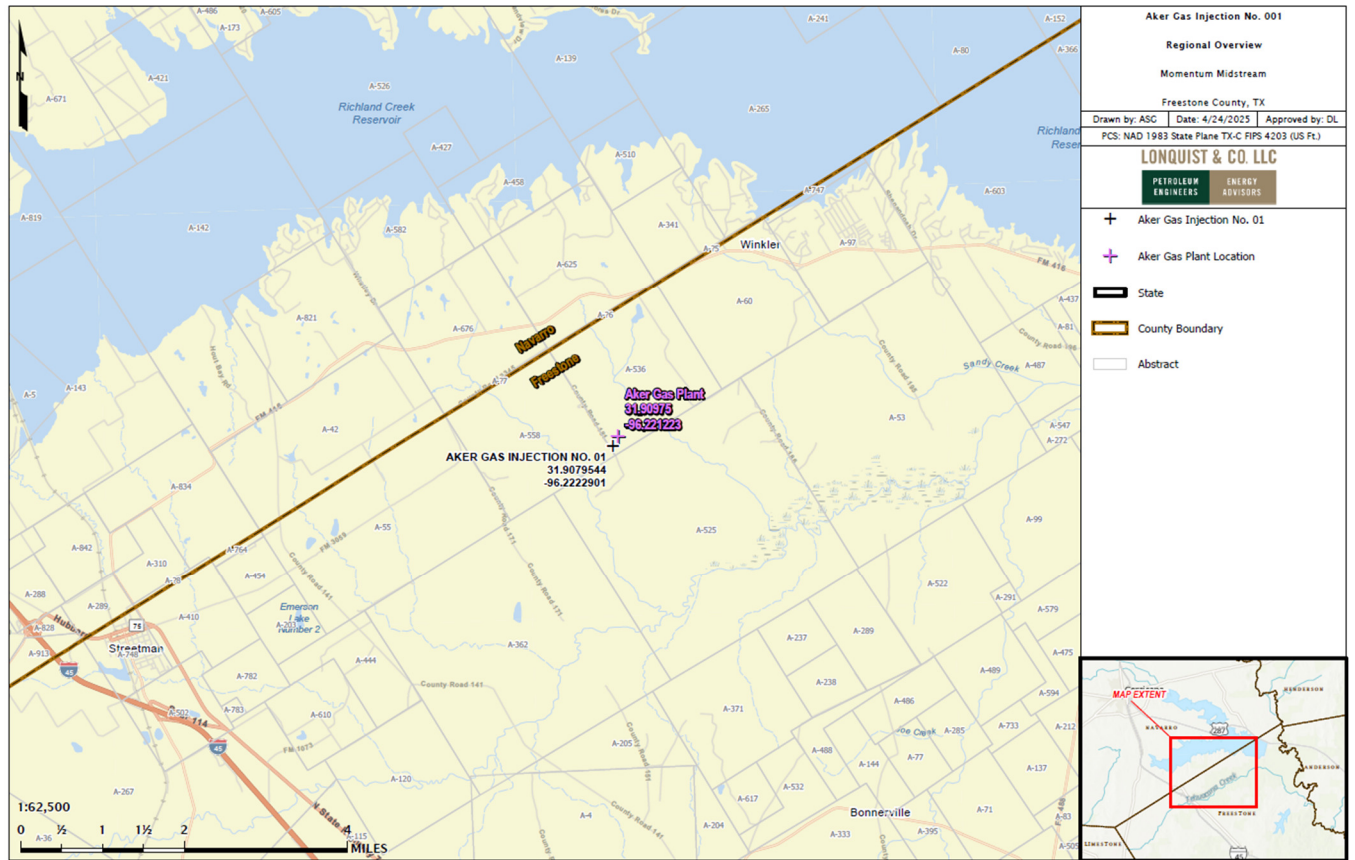

Figure 1 – Location of the Aker Gas Plant and Aker No. 1 Well

ACRONYMS AND ABBREVIATIONS

40 CFR	Title 40, U.S. Code of Federal Regulations
AAPG	American Association of Petroleum Geologists
AMA	active monitoring area
AOR	area of review
API	American Petroleum Institute
BEG	Bureau of Economic Geology
BHP	bottomhole pressure
BUQW	Base of Usable Quality Water
CFR	U.S. Code of Federal Regulations
CCS	Carbon Capture and Storage
DCSM	Distribution Control System Monitoring
EOS	equation of state
ESD	emergency shutdown (valve)
GAU	Groundwater Advisory Unit
GHG	greenhouse gas (emissions)
GHGRP	Greenhouse Gas Reporting Program
ILD	deep induction log
Ma	million years ago
mD	millidarcy
mg/L	milligrams per liter
MIT	mechanical integrity test
MMA	maximum monitoring area
MMscf/d	million standard cubic feet per day
MMT	million metric tons
MRV	Monitoring, Reporting, and Verification
NACE	National Association of Corrosion Engineers
NAD	North American Datum
NIST	National Institute of Standards and Technology
NSHM	National Seismic Hazard Model

OBG	overburden gradient
ppm	parts per million
psi/ft	pounds per square inch per foot
QA/QC	quality assurance/quality control
RSC	residual sodium carbonate
SAR	sodium-adsorption ratio
SAU	storage assessment unit
SCADA	Supervisory Control and Data Acquisition
SP	spontaneous potential
SWR	Statewide Rule
TAC	Texas Administrative Code
TDS	total dissolved solids
TEC	tubing encapsulated conductor
TRRC	Railroad Commission of Texas
TVD	true vertical depth
TVDSS	true vertical depth subsea
TWDB	Texas Water Development Board
UIC	Underground Injection Control
USDW	Underground Source of Drinking Water
USGS	U.S. Geological Survey
WHP	wellhead pressure
XRD	X-ray Diffraction

TABLE OF CONTENTS

INTRODUCTION	2
ACRONYMS AND ABBREVIATIONS.....	4
SECTION 1 – FACILITY INFORMATION	10
1.1 Reporter Number:	10
1.2 Underground Injection Control Permit Class: Class II	10
1.3 UIC Well Identification Number:	10
1.4 Facility Address	10
SECTION 2 – PROJECT DESCRIPTION	11
2.1 Sources of CO₂	11
2.2 Regional Geology	13
2.3 Structural Setting and Regional Faulting	16
2.4 Site Characterization	19
2.5 Stratigraphy and Lithologic Characteristics	19
2.6 Formation Top Depths	21
2.7 Injection Interval – Woodbine Formation (94 Ma to 96 Ma)	21
2.7.1 Porosity and Permeability Development.....	24
2.7.2 Woodbine Formation Fluid.....	27
2.7.3 Fracture Gradient Discussion.....	29
2.8 Upper Confining Zone – Eagle Ford Shale (89 Ma to 94 Ma)	30
2.9 Lower Confining Zone – Maness Shale (96 Ma to 97 Ma)	35
2.9.1 Injection and Confinement Summary.....	36
2.10 Local Structure	37
2.11 Groundwater Hydrology	39
2.12 Surface Water Hydrology	43
2.12.1 Richland-Chambers Reservoir.....	43
2.12.2 Fairfield Lake.....	43
2.12.3 Trinity River.....	43
2.13 Base of USDW Determination	43
2.14 Reservoir Characterization Modeling	45
2.14.1 Reservoir Modeling – Woodbine.....	45
2.15 Simulation Modeling	48
SECTION 3 – DELINEATION OF MONITORING AREA.....	57
3.1 Maximum Monitoring Area	57
3.2 Active Monitoring Area	57
SECTION 4 – POTENTIAL PATHWAYS FOR LEAKAGE.....	59
4.1 Leakage from Surface Equipment	60
4.2 Leakage from Wells in the MMA	61
4.2.1 Existing Wells Within the MMA.....	61
4.2.2 Future Drilling	64
4.2.3 Freshwater Wells	64
4.3 Leakage Through Faults or Fractures	66
4.4 Leakage Through Confining Layers	66
4.5 Leakage from Natural or Induced Seismicity	66
SECTION 5 – MONITORING FOR LEAKAGE.....	69

5.1	Leakage from Surface Equipment	70
5.2	Leakage from Wells Within MMA	71
5.2.1	Leakage from Wells that Penetrate the Upper Confinement	71
5.2.2	Leakage from Future Wells within MMA.....	73
5.2.3	Leakage Through Groundwater Wells Within MMA	78
5.3	Leakage Through Faults, Fractures, or Confining Layer	78
5.4	Leakage Through Natural or Induced Seismicity	78
SECTION 6 – BASELINE DETERMINATIONS		80
6.1	Visual Inspections	80
6.2	CO₂/H₂S Detection	80
6.3	Operational Data	80
6.4	Continuous Monitoring	80
6.5	Groundwater Monitoring	81
SECTION 7 – SITE-SPECIFIC CONSIDERATIONS FOR MASS BALANCE EQUATION		82
7.1	Mass of CO₂ Received	82
7.2	Mass of CO₂ Injected	82
7.3	Mass of CO₂ Produced	83
7.4	Mass of CO₂ Emitted by Surface Leakage and Equipment Leaks	83
7.5	Mass of CO₂ Sequestered	84
7.6	Mass of CO₂ Emitted Due to Leaks Other Than Surface Equipment	84
SECTION 8 – IMPLEMENTATION SCHEDULE FOR MRV PLAN		85
SECTION 9 – QUALITY ASSURANCE.....		86
9.1	Monitoring Quality Assurance and Quality Control	86
9.2	Missing Data	86
9.3	MRV Plan Revisions	87
SECTION 10 – RECORDS RETENTION		88
REFERENCES.....		89

Figures

Figure 1 – Location of the Aker Gas Plant and Aker No. 1 Well	3
Figure 2 – Aker Gas Plant and Aker No. 1.....	12
Figure 3 – Regional East Texas Basin Locator Map showing the location of Aker No. 1 (modified from Roberts-Ashby et al., 2012).	13
Figure 4– Cretaceous stratigraphic column of the East Texas Basin as encountered at the Aker No. 1 location (modified from Calavan, 1985).....	14
Figure 5 – Formation thickness of the Woodbine in the East Texas Basin (modified from Calavan, 1985). ...	15
Figure 6– Regional type log cross section from west (left) to east (right) across the East Texas Basin (modified from Hentz and Ruppel, 2011). The location of the Aker No. 1 is indicated by the yellow star, near the western-most (far left) well on the cross section.	16
Figure 7 – Major structural features bounding the East Texas Basin with the location of the Aker No. 1 indicated by the yellow star (modified from Swanson et al., 2016).	18
Figure 8– Aker No. 1 (API No. 42-161-34475) open-hole log showing injection and confining zones. The left track has SP (black) and Gamma Ray (green); deep resistivity, AT90, is displayed on a logarithmic scale on the right track.	20
Figure 9 – Schematic cross section illustrating regional lithostratigraphic and lithofacies relationships across the Eagle Ford Group (from Hentz et al., 2014).	22

Figure 10 – Framework mineralogy of Woodbine sandstones plotted on the Folk (1974) ternary diagram (from Loucks et al., 2015).23

Figure 11– Cross section X-X' through the Aker Monitor Well No. 1, the Aker No. 1, and the Aker Monitor Well No. 2, from left to right, respectively.24

Figure 12 – Reference basemap showing the location of cross section X-X' through the Aker Monitor Well No. 1, the Aker No. 1, and the Aker Monitor Well No. 2, from NW-SE, respectively. The maximum monitoring area (MMA) of the 12-year plume at stabilization plus one half mile buffer (dashed red outline) and all the wells within those limits are displayed on the map.25

Figure 13 – Histogram showing porosity distribution from the three type logs. The average porosity of the injection zone was calculated to be 21.2% +/- 6.7% standard deviation.26

Figure 14 – Porosity versus permeability scatter plot for Woodbine sandstone samples from the East Texas Field. High- and low-end porosity range values as well as average porosity were projected onto the best-fit line (dashed pink) to estimate a permeability range and average (modified from Loucks et al., 2015).27

Figure 15 – Regional Woodbine Salinity Map with the location of the Aker No. 1 indicated by the yellow star, which falls within a salinity range of 60,000 ppm to 70,000 ppm (from Texas Water Development Board, Report 157).29

Figure 16 – Representative thin section photographs of Eagle Ford mudstones: (A) finely laminated, moderately silty, carbonaceous shale; (B) calcareous mudstone with calcite-cemented microfractures; (C) interlaminated very silty shale and argillaceous quartzose siltstone; (D) very silty mottled mudstone with authigenic pyrite nodules (lower left); (E) weakly laminated, carbonaceous and argillaceous, quartzose siltstone; and (F) finely laminated, very fossiliferous (foraminifers and phosphatic bioclasts), carbonaceous shale (from Dawson and Almon, 2010).32

Figure 17 – Representative mineralogical constituents of Eagle Ford shale across different oil and gas regions (Stoneburner, 2014).33

Figure 18 – Isochore map of the Eagle Ford shale, upper confining zone (UCZ).34

Figure 19 – Isochore map of the Maness shale, lower confining zone (LCZ).36

Figure 20 – TVD subsea structure map of the Top of the Woodbine injection zone (IZ).38

Figure 21 – Stratigraphic and hydrogeologic units near Freestone County, Texas39

Figure 22 – Map showing the location of the Aker No. 1 in relation to the major aquifers of Texas (modified from Bruun et al., 2016).40

Figure 23 – (a) Structural cross section of the Carrizo-Wilcox Aquifer and overlying strata with the location of the Aker No. 1 projected onto the cross section, and (b) reference map showing the location of the cross section line and Aker No. 1 (modified from Bruun et al., 2016).41

Figure 24 – Total Dissolved Solids (TDS) Map of the Carrizo-Wilcox Aquifer System, showing the location of the Aker No. 1, which is in a predominantly fresh water (< 1,000 mg/L) region.42

Figure 25 – Groundwater and USDW letter issued as part of the Aker No. 1 Class II permit (accessed from Texas Railroad Commission, February 25, 2025).44

Figure 26 – Two-Phase Relative Permeability Curves Used in the tNavigator Model.47

Figure 27 – Areal View of Woodbine Gas Saturation Plume at Shut-in (End of Injection).50

Figure 28 – Areal View of Woodbine Saturation Plume at 25 Years After Shut-in (Stabilized).51

Figure 29 – West-East Cross-Sectional View of Woodbine Gas Saturation Plume at Shut-in (End of Injection).52

Figure 30 – West-East Cross-Sectional View of Woodbine Gas Saturation Plume at 25 Years After Shut-in (Stabilized).53

Figure 31 – Well Injection Rate and Bottomhole and Surface Pressures Over Time, Woodbine.55

Figure 32 – Delineation of Maximum Monitoring Area.58

Figure 33 – Aker No. 1 Process Flow Diagram61

Figure 34 – Aker No. 1 Wellbore Schematic62

Figure 35 – Wells That Penetrate the Upper Confinement Within the Maximum Monitoring Area.....	63
Figure 36 – Groundwater Wells within the MMA.	65
Figure 37 – Hazard map from the 2023 National Seismic Hazard Model Project with the approximate location of Akers No. 1 represented by the red star (modified from USGS, 2023).....	66
Figure 38 – BEG TexNet Earthquake Catalog query within a 25 km (15.5 mi) radius of the Akers No. 1 location shown by the red star. The query returned zero (0) earthquakes within the queried radius.	67
Figure 39 – USGS Earthquake Catalog query within a 25 km (15.5 mi) radius of the Akers No. 1 location which returned zero (0) earthquakes within the queried radius.	67
Figure 40 – USGS Earthquake Catalog query within a 100 km (62.1 mi) radius of the Akers No. 1 location to identify the closest recorded seismic event(s). These occurrences are all well outside of the AOR and are only shown for informative purposes.	68
Figure 41 – Wells that Penetrate the Upper Confinement Within the MMA.	72
Figure 42 – Aker No. 1 Wellbore Schematic.	74
Figure 43 – Aker No. 1 Monitoring and Safety Equipment.	76
Figure 44 – Aker No. 1 Monitoring and Safety Equipment (Part 2).....	77
Figure 45 – Map showing nearest TexNet monitoring station No. 237B, located 40 km east-northeast of Akers No. 1.	79

Tables

Table 1 – Expected Gas Composition	2
Table 2 – Formation Top Depths, as encountered in the Aker AGI No. 1.	21
Table 3 – Framework mineralogy constituents, by volume, of typical Woodbine sandstones.	23
Table 4 – Produced Woodbine Formation Water Characteristics for wells in Freestone, Texas, and surrounding counties (data from USGS National Produced Waters Database, v2.3, accessed Feb. 14, 2025).	28
Table 5 – Fracture Gradient calculation inputs and results for the Aker Gas Injection No. 01 well.	30
Table 6 – Numerical approximations of Eagle Ford shale mineral constituents (values approximated from Stoneburner, 2014).	33
Table 7 – Mineralogy by XRD of Maness Shale samples (Patterson and Denne, 2019).....	35
Table 8 – Modeled Initial Gas Composition.....	46
Table 9 – Key Inputs to Reservoir Model, Woodbine.....	46
Table 10 – tNavigator Model Layer Package Properties.	48
Table 11 – Historical and Future BHP	56
Table 12 – Potential Leakage Pathway Risk Assessment.....	59
Table 13 – Summary of Leakage Monitoring Methods.	69

SECTION 1 – FACILITY INFORMATION

Key information regarding the CO₂ injection facilities is described in this section.

1.1 Reporter Number:

- Greenhouse Gas Facility Name: Aker Gas Plant
- Current Greenhouse Gas Reporting Program ID: 1003129 Subparts C-II, SS, and TT
 - Midcoast G&P will update its reporting information to include Subpart RR with the submittal of this Monitoring, Reporting, and Verification Plan
- Operator: Midcoast G&P (East Texas) L.P.
- Location: North American Datum of 1983 (NAD 83) 31.9079544, -96.2222901

1.2 Underground Injection Control Permit Class: Class II

The TRRC regulates oil and gas activities in Texas and has primacy to implement the Underground Injection Control (UIC) Class II program. On June 22, 2010, the TRRC issued a Class II oil and gas waste permit for Aker No. 1 in accordance with Statewide Rules 9 and 36, with a Permit Amendment (Permit No. 13099 Amendment) approved on November 15, 2023.

1.3 UIC Well Identification Number:

- 000101798

1.4 Facility Address

261 FCR 181
STREETMAN, TX, 75859

SECTION 2 – PROJECT DESCRIPTION

This section outlines the geologic context, planned injection volumes, and reservoir modeling conducted by Lonquist Sequestration, LLC, for the Aker Gas Injection Well No. 1 (Aker No. 1). Midcoast G&P injects an acid gas mixture of CO₂ and H₂S into the Woodbine Formation by way of Aker No. 1 for sequestration. The Aker Gas Plant and Aker No. 1 are designed and operated to prevent leaks from mechanical systems and the injection zone, safeguarding the Underground Source of Drinking Water USDW and preventing surface releases. The Woodbine Formation, the designated injection zone, is protected by multiple overlying formations that ensure subsurface containment. The Eagle Ford shale serves as the upper confinement zone (UCZ), with the Maness Shale providing additional lower confinement.

2.1 Sources of CO₂

The acid gas stream injected into the Aker No. 1 well is separated from the production gas stream at the amine unit at the Aker Gas Plant in Freestone County, Texas. From the amine unit, the acid gas stream is measured, sampled, and pumped to the nearby Aker No. 1 well and injected into the disposal formation. The acid gas stream from the Aker Gas Plant is the only source of CO₂ to be injected into the Aker No. 1 well. An image of the Aker Plant and surrounding facilities is presented in Figure 2.



Figure 2 – Aker Gas Plant and Aker No. 1.

2.2 Regional Geology

The Aker No. 1 site lies in Freestone County, Texas, within the East Texas basin, as depicted in Figure 3. This basin, one of three Mesozoic basins along the northern Gulf Coastal Plain, formed as complex rift systems on thinned continental crust during the Triassic Period (Foote et al., 1988). Initial rifting and crustal thinning, combined with later sediment loading, led to more than 23,000 feet (ft) of subsidence in the center of the basin (Jackson and Seni, 1984). The basin covers more than 68,000 square miles (Dolton et al., 1981) and is a major oil and gas producing basin from Cretaceous aged strata.

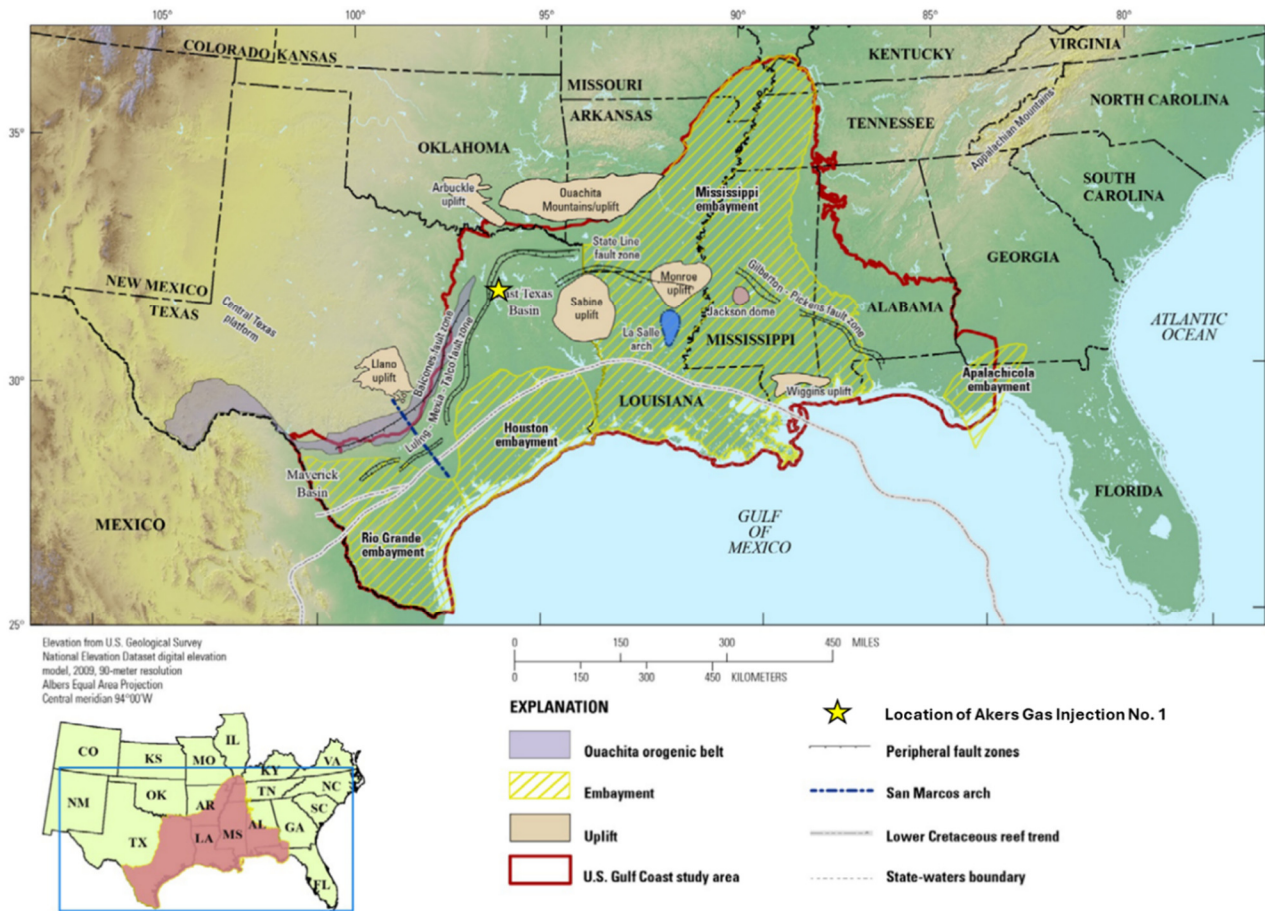

Figure 3 – Regional East Texas Basin Locator Map showing the location of Aker No. 1 (modified from Roberts-Ashby et al., 2012).

The Woodbine Formation, the primary injection zone, was laid down on the submerged Upper Cretaceous shelf before the Sabine Uplift's emergence. It rests atop the Buda Limestone and is erosionally overlain by the Eagle Ford Shale and Austin Chalk Formations, as illustrated in the stratigraphic column in Figure 4. The column highlights key injection and confining zones at the proposed Aker No. 1 site.

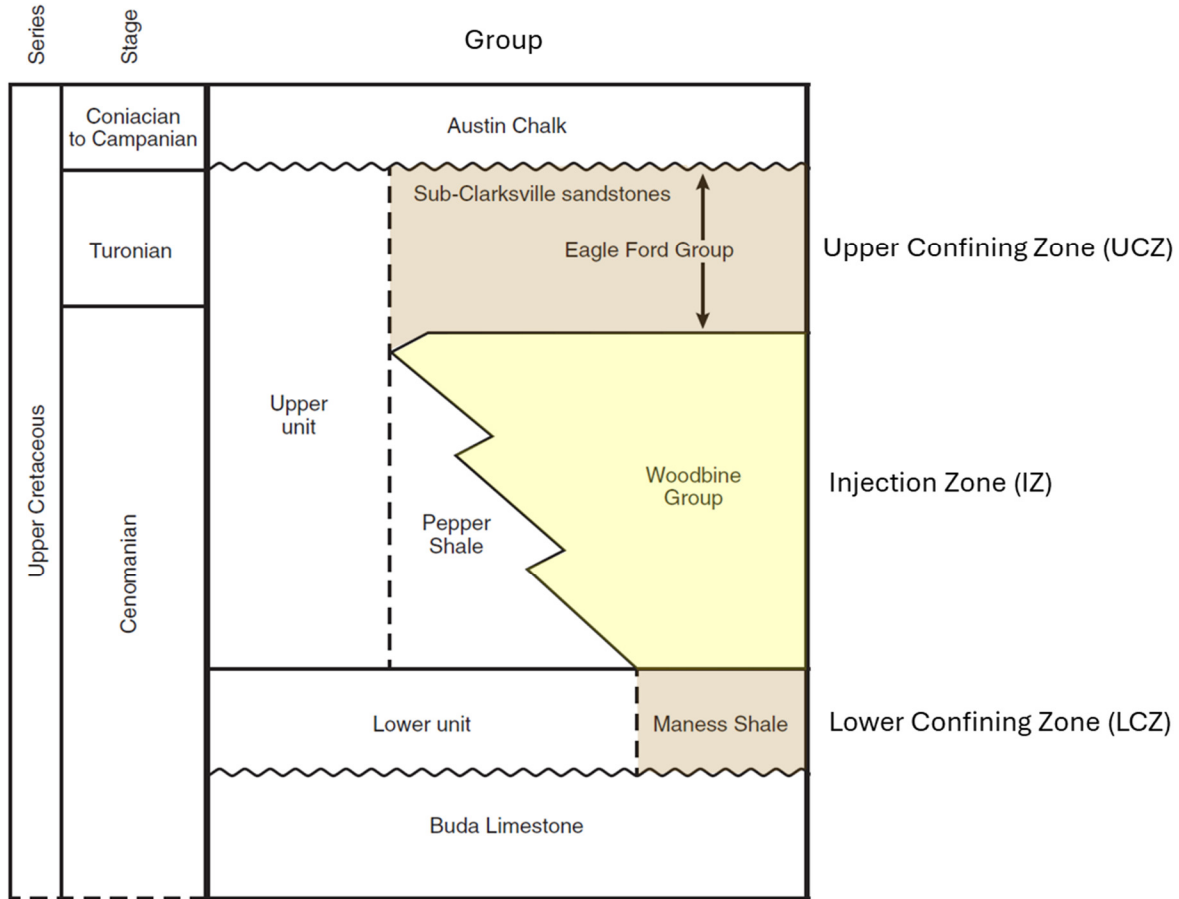

Figure 4– Cretaceous stratigraphic column of the East Texas Basin as encountered at the Aker No. 1 location (modified from Calavan, 1985).

The Woodbine is an unconformity-bounded unit recording numerous high-frequency sequences, composed predominantly of siliciclastic sediment delivered by the Woodbine delta system. Erosion of the Sabine uplift is commonly interpreted as the dominant sediment source for the Woodbine and Eagle Ford Groups in the East Texas Basin (Ewing, 2009). The Woodbine and Eagle Ford successions are unconformably bound by the Buda Limestone below and the Austin Chalk above, with both erosional surfaces representing significant hiatuses in sediment deposition (Meyer et al., 2021).

There is considerable variation in thickness and facies across the greater East Texas Basin, as shown in the regional isopach map in Figure 5 and regional cross section in Figure 6. While the axis of the Woodbine delta system is largely responsible for variations in thickness east-to-west across the basin, variations from north-to-south are controlled by other depositional factors. The typically much thicker northern parts of the basin are dominated by sandstone-prone shelf-margin-to-fluvial

deposits (Ambrose et al., 2009). Whereas in the southern extension of the basin, referred to as the Brazos Basin, correlative Woodbine strata is commonly found on the order of 100 ft thick and is dominated by argillaceous, basinal mudstone. This north-to-south thickness variation and shelf, slope, and basin profile create relict physiography onto which depositional sequences in the Eagle Ford Group sequentially lap.

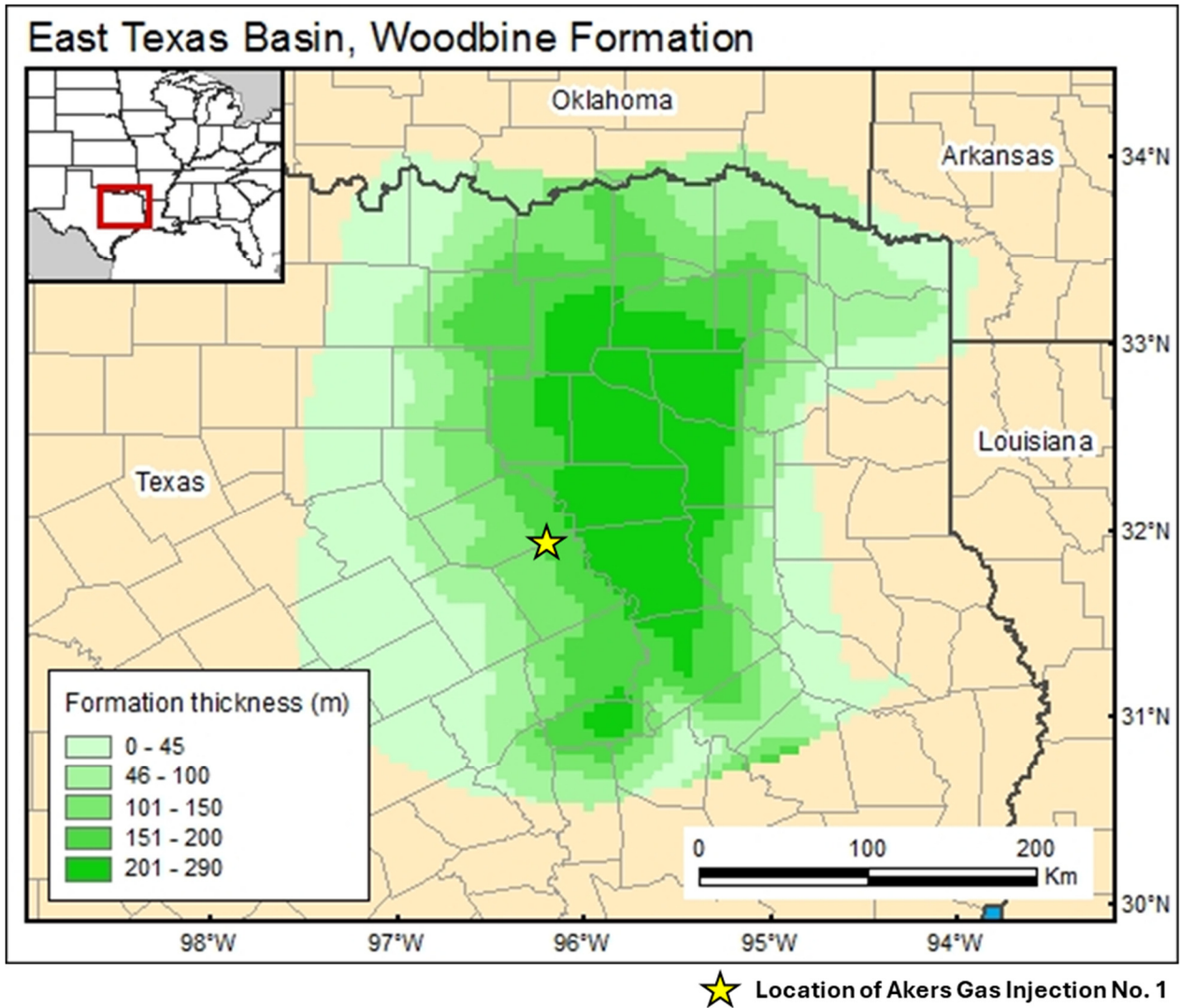

Figure 5 – Formation thickness of the Woodbine in the East Texas Basin (modified from Calavan, 1985).

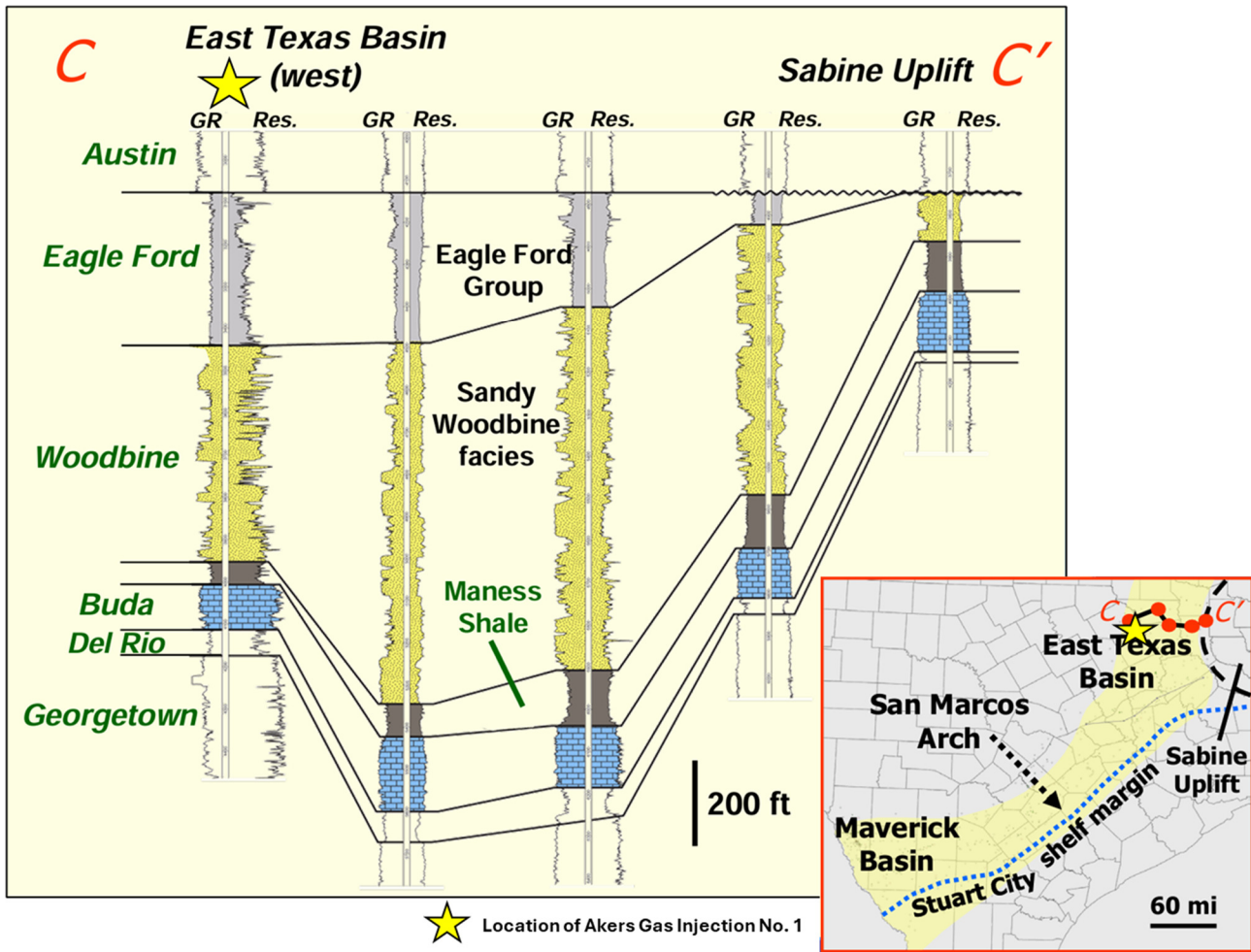

Figure 6— Regional type log cross section from west (left) to east (right) across the East Texas Basin (modified from Hentz and Ruppel, 2011). The location of the Aker No. 1 is indicated by the yellow star, near the western-most (far left) well on the cross section.

2.3 Structural Setting and Regional Faulting

The Gulf of Mexico basin was formed by crustal extension and seafloor spreading associated with the Mesozoic breakup of Pangea. Rifting of northwest to southeast (NW-SE) trending transfer faults during the Middle Jurassic lasted approximately 25 million years and resulted in a variable thickness of transcontinental crust underlying the region. By the Lower Cretaceous time, the general outline and morphology of the Gulf were similar to that of the present day (Galloway, 2008; Yurewicz et al., 1993).

Lower Cretaceous tectonic activity was limited to regional subsidence associated with areas of variable crustal thickness and local structuring caused by movement of the Louann Salt (Yurewicz et al., 1993). The combination of these processes resulted in the structural development of regional arches, grabens, uplifts, embayments, salt domes, and salt basins around the northern

edge of the basin (Dennen and Hackley, 2012; Galloway, 2008). The locations of these structural features are displayed in Figure 7 relative to the Aker No. 1 location.

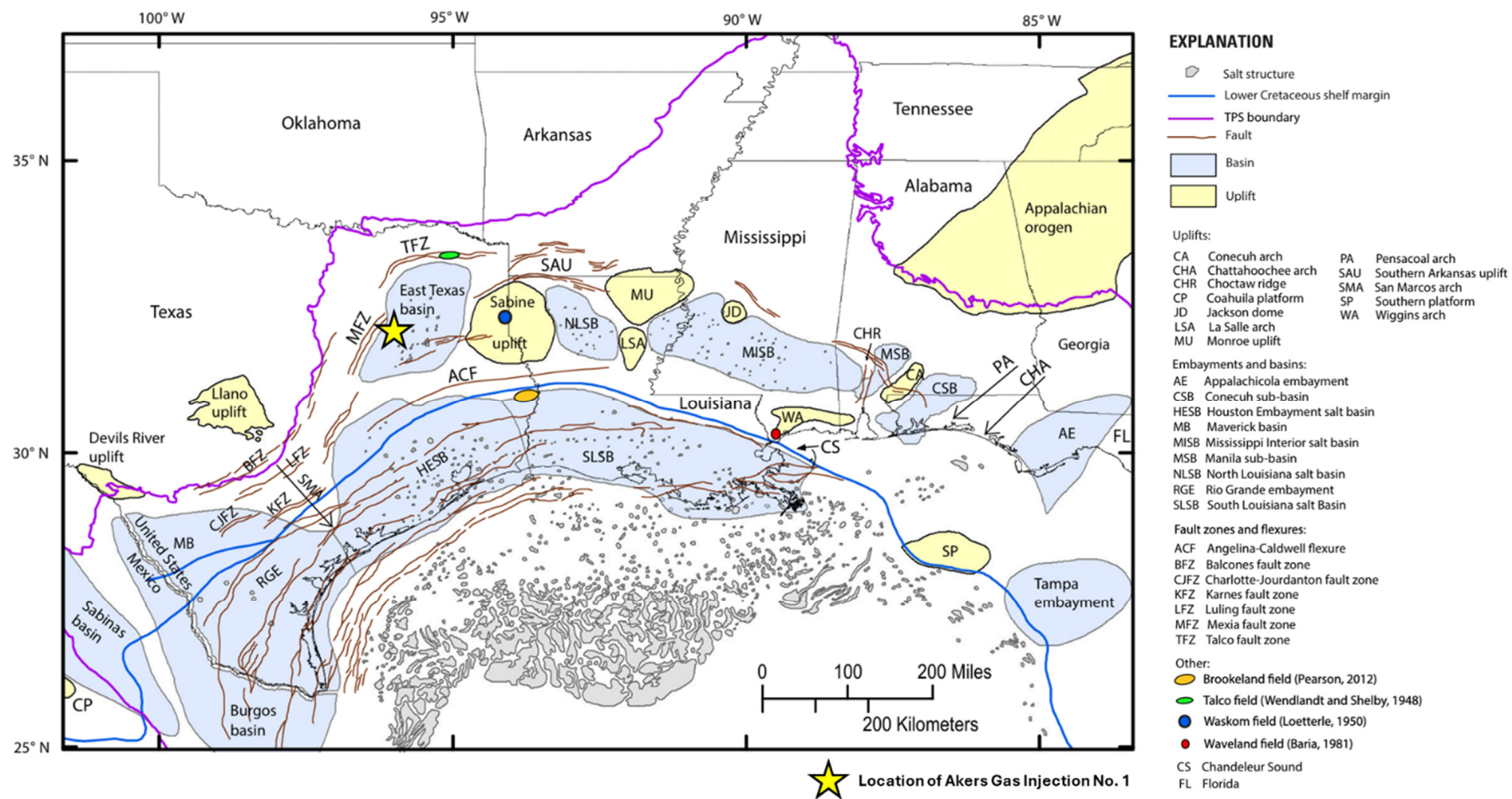

Figure 7 – Major structural features bounding the East Texas Basin with the location of the Aker No. 1 indicated by the yellow star (modified from Swanson et al., 2016).

The Sabine Arch forms the eastern boundary while a series of both normal and thrust fault systems—the Ouachita, Balcones, Luling, and Mexia-Talco Fault Zones—provide the western and northern boundaries of the East Texas basin. The mobilization of the Louann Salt is believed to be responsible for the initial movement of these major fault systems. The southern boundary is marked by the Angelina Caldwell Flexure.

2.4 Site Characterization

The Aker No. 1 is in Abstract A-536 of the J. Richards Survey in Freestone County, Texas. Midcoast G&P has a lease agreement with the landowners for the 5.17-acre tract where the Aker No. 1 is located. The following section discusses the geologic character of this site.

2.5 Stratigraphy and Lithologic Characteristics

Figure 8 shows an open-hole log from the Aker No. 1 (API No. 42-161-34475), with the injection interval and confining zones annotated on the log. The well was originally completed on June 27, 2011, through the perforations from 3,905 ft to 3,948 ft, from 4,056 ft to 4,061 ft, from 4,066 ft to 4,080 ft, and from 4,144 ft to 4,184 ft, which are plotted on the log image in Figure 8. These perforations are still active today for acid gas injection.

★
AKER GAS INJECTION 1
42161344750000

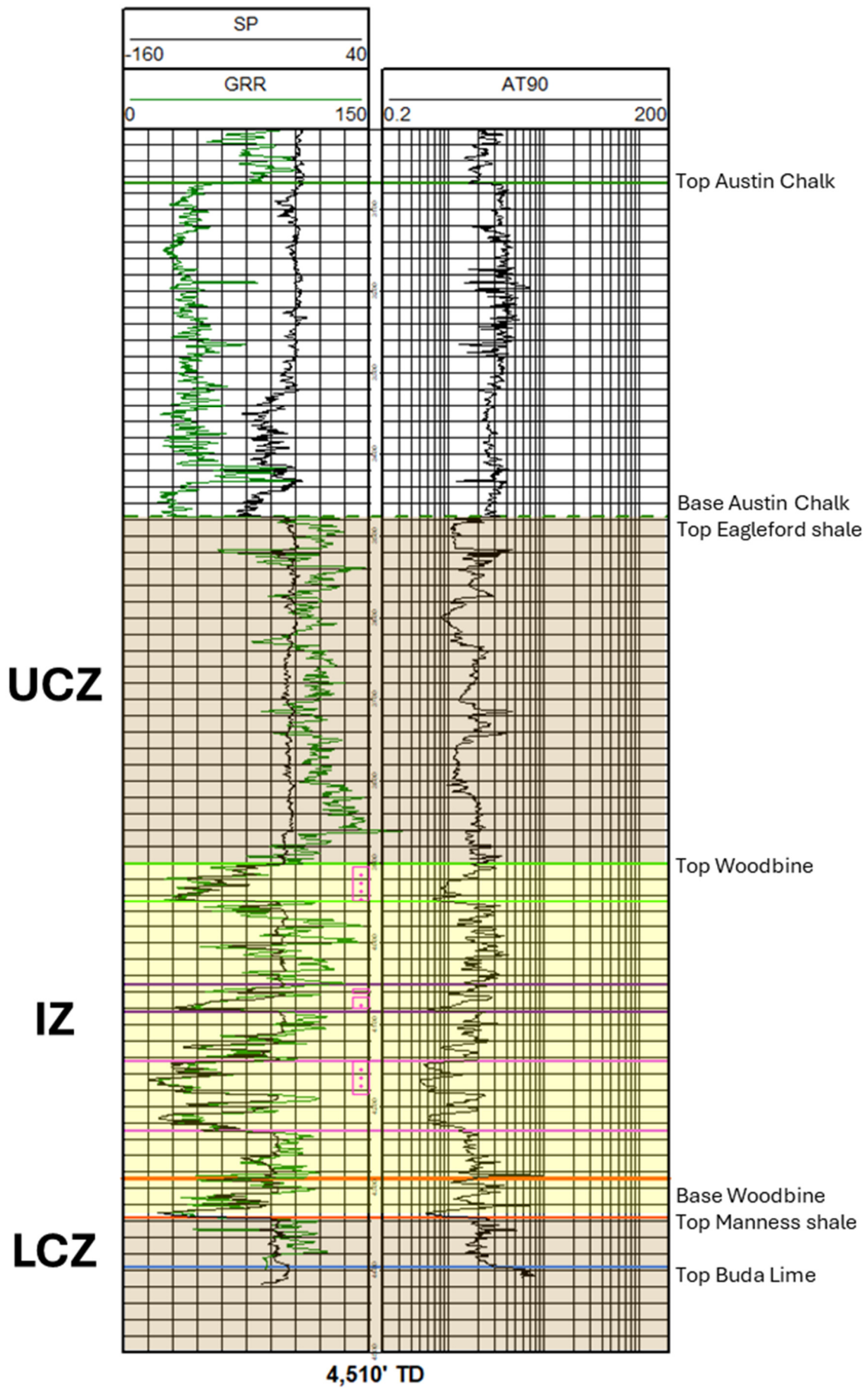

Figure 8– Aker No. 1 (API No. 42-161-34475) open-hole log showing injection and confining zones. The left track has SP (black) and Gamma Ray (green); deep resistivity, AT90, is displayed on a logarithmic scale on the right track.

2.6 Formation Top Depths

Key regional formation tops were picked and correlated across well logs within 5 mi of the Aker No. 1 AGI site. Structure maps were produced on these horizons to gain an understanding of bed dip and structural features within the Aker No. 1 AGI area. Table 2 lists the depths of key formation tops as encountered in the Aker No. 1 AGI well, along with relevant comments related to the ongoing acid gas injection operations.

Table 2 – Formation Top Depths, as encountered in the Aker AGI No. 1.

Formation Top	TVD (true vertical depth)	Notable Information
Base Wilcox	425'	-Base of usable-quality groundwater/freshwater aquifers
Top Pecan Gap	2,155'	
Top Austin Chalk	3,068'	
Base USDW	3,150'	-Potential USDW to protect (GAU letter)
Base Austin Chalk/Top Eagle Ford Shale	3,477'	-Top of UCZ
Base Eagle Ford Shale/Top Woodbine "A"	3,903'	-Base of UCZ/Top of IZ
Base Woodbine "A"	3,949'	
Top Woodbine "B"	4,051'	
Base Woodbine "B"	4,084'	
Top Woodbine "C"	4,144'	
Base Woodbine "C"	4,230'	-Base of IZ
Top Woodbine "D"	4,288'	
Base Woodbine "D"/Top Maness Shale	4,337'	-Top of LCZ
Top Buda Lime	4,397'	-Top of secondary LCZ

GAU – Groundwater Advisory Unit

IZ – injection Zone

LCZ – Lower Confining Zone

UCZ – Upper Confining Zone

USDW – Underground Source of Drinking Water

2.7 Injection Interval – Woodbine Formation (94 Ma to 96 Ma)

The proposed injection interval of the Aker No. 1 is the siliciclastic Upper Cretaceous, Woodbine Formation. The Woodbine is a fluvial and deltaic formation that prograded from the north into the East Texas Basin (Hovorka, 1999). The Aker No. 1 is located within what is referred to as the "Eaglebine" trend, which comprises of the Cenomanian Maness Shale (LCZ), Woodbine Group (IZ), and upper Cenomanian and Turonian Eagle Ford Group (UCZ), as shown in Figure 9. Aerially, the play is defined primarily by the subsurface distribution of Woodbine Group and Eagle Ford sandstones and equivalent mudrock facies; therefore, the name Eaglebine (Hentz et al., 2014).

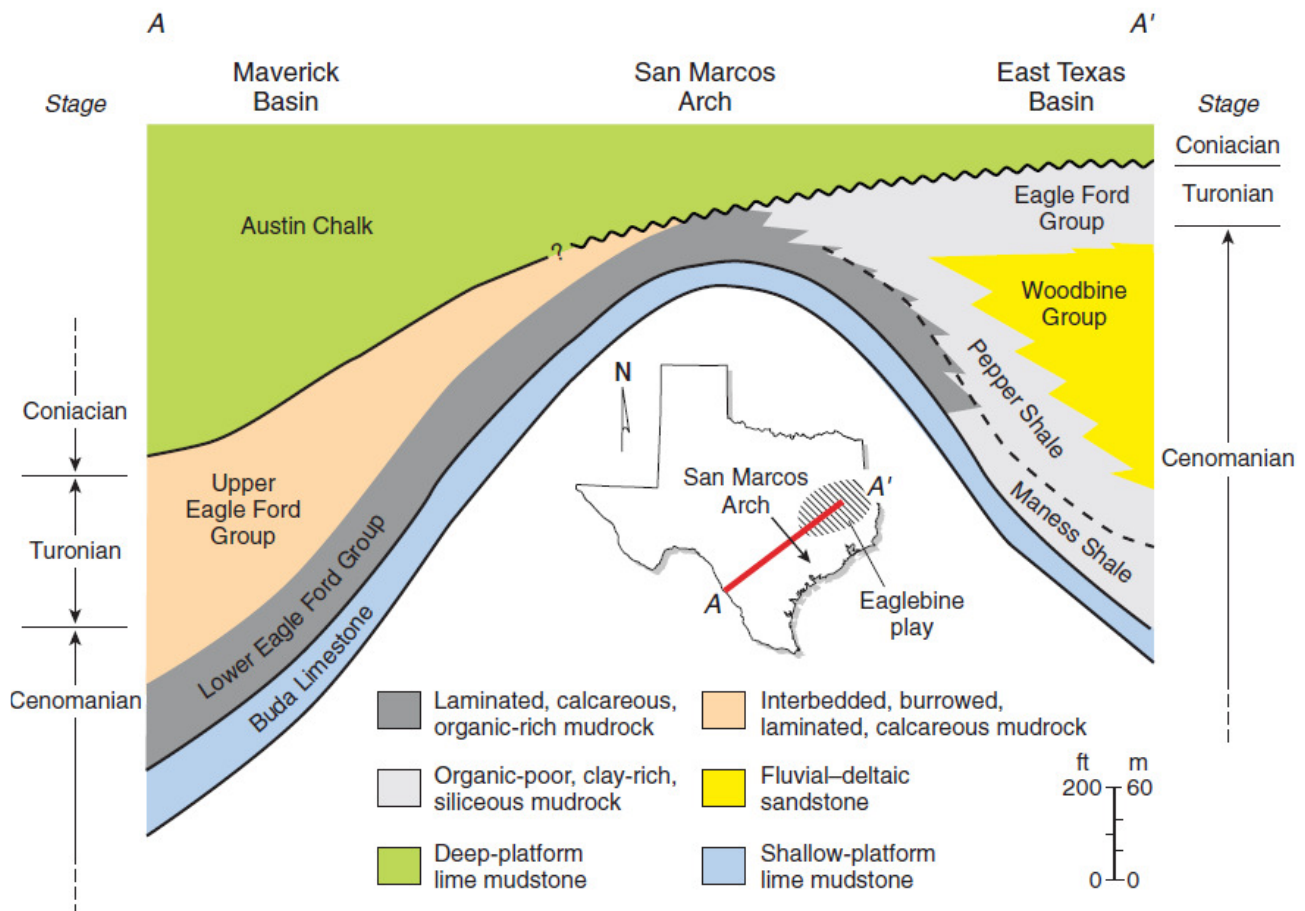

Figure 9 – Schematic cross section illustrating regional lithostratigraphic and lithofacies relationships across the Eagle Ford Group (from Hentz et al., 2014).

The Woodbine Formation is composed of arkosic quartzarenites having calcite, dolomite, ankerite, quartz, kaolinite, illite, and smectite as the dominant diagenetic phases, and contains sodium chloride (NaCl) brines (Hovorka, 1999). Woodbine sandstones commonly have more than 95% framework quartz with a few samples in the sublitharenite field using the classification of Folk (1974), as shown in Figure 10. Mineralogy constituents on average point-count data for Woodbine sandstones are presented in Table 3.

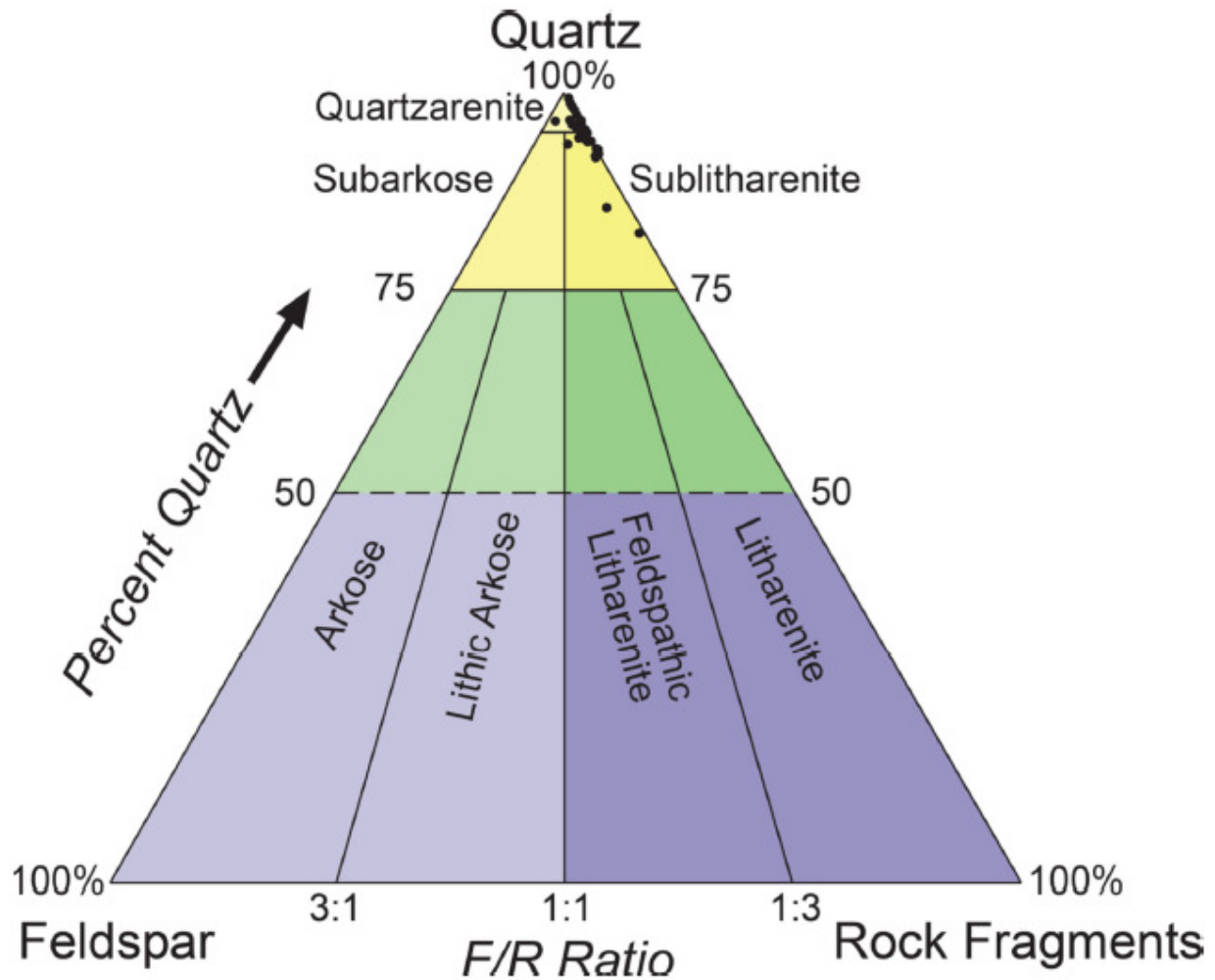

Figure 10 – Framework mineralogy of Woodbine sandstones plotted on the Folk (1974) ternary diagram (from Loucks et al., 2015).

Table 3 – Framework mineralogy constituents, by volume, of typical Woodbine sandstones.

Woodbine Sandstone (IZ)	
Mineral Constituent	% Framework (by volume)
Quartz	95%
K-feldspar	2%
Plagioclase feldspar	1%
Micas	1%
Rock fragments (volcanic/chert)	1%

The following subsections outline the porosity and permeability distributions, formation water geochemistry, and fracture gradient discussion of the Woodbine injection interval found between depths of 3,903 ft and 4,337 ft true vertical depth (TVD) in the Aker No. 1.

2.7.1 Porosity and Permeability Development

Three modern-type logs were selected to represent the rock properties of the injection and confining intervals. These logs include the Aker No. 1 and the two monitoring wells, which are shown in the NW-SE cross section in Figure 11. A larger image of Figure 11 is provided in Appendix A. A reference map showing the location of the cross section is shown in Figure 12. The Aker Monitoring Well No. 1 is located 4,150 ft northwest of the AGI well, and the Aker Monitoring Well No. 2 is located 4,285 ft southeast of the AGI well. These three wells were all drilled in April 2011 or May 2011, and open-hole triple combo logs were run by Schlumberger, thus providing consistent data points proximal to the actual Aker No. 1 location.

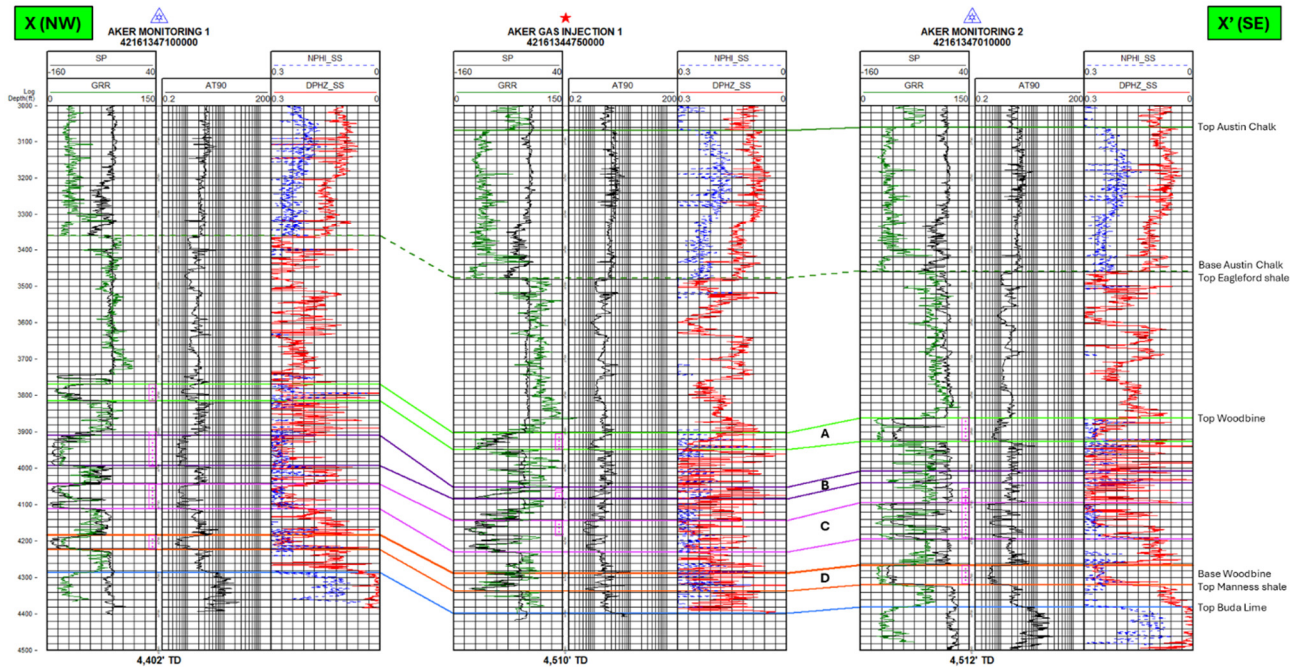

Figure 11– Cross section X-X' through the Aker Monitor Well No. 1, the Aker No. 1, and the Aker Monitor Well No. 2, from left to right, respectively.

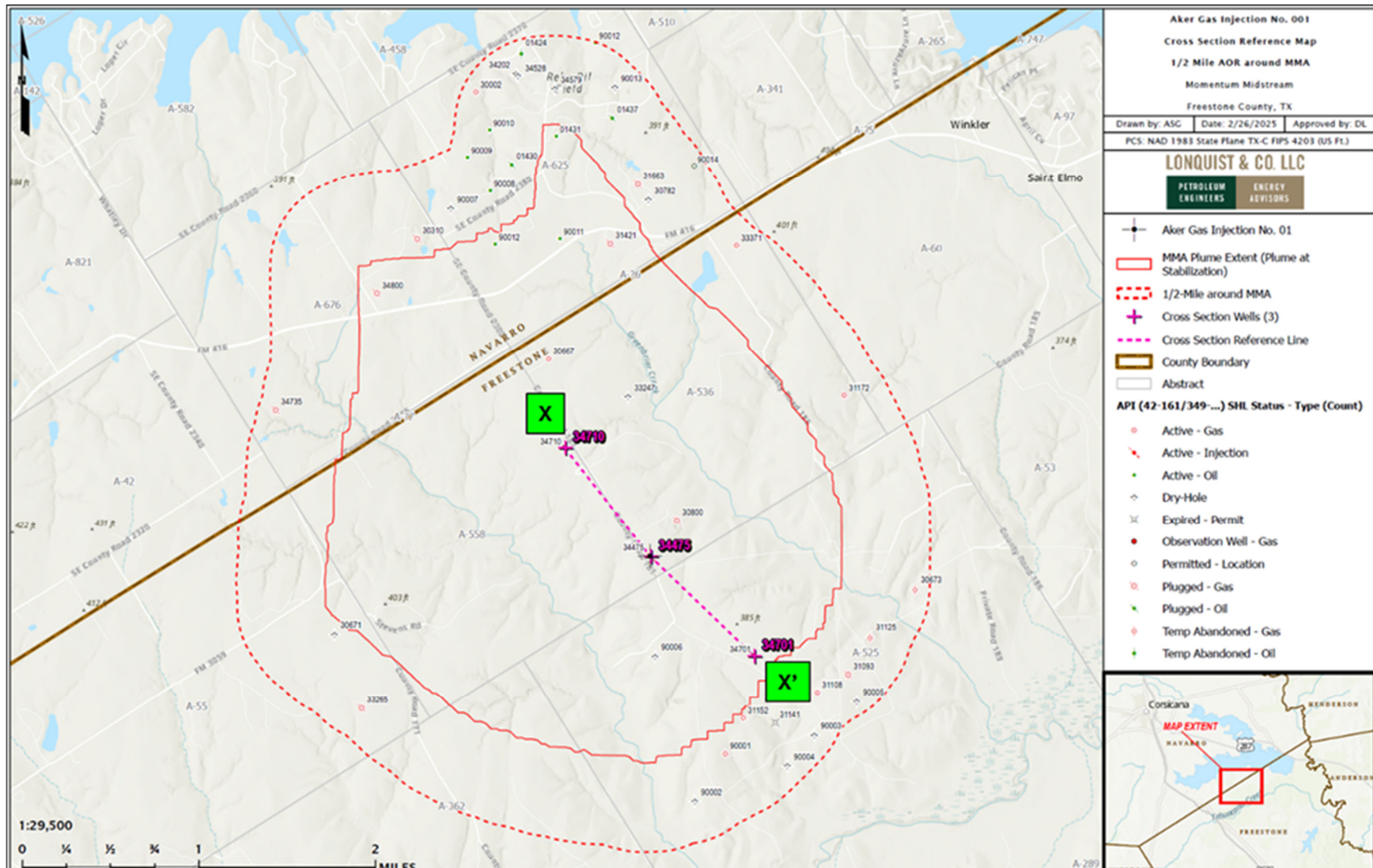

Figure 12 – Reference basemap showing the location of cross section X-X' through the Aker Monitor Well No. 1, the Aker No. 1, and the Aker Monitor Well No. 2, from NW-SE, respectively. The maximum monitoring area (MMA) of the 12-year plume at stabilization plus one half mile buffer (dashed red outline) and all the wells within those limits are displayed on the map.

Average porosity values of the different zones were calculated directly from the density porosity measurements in the three type logs. A histogram showing the distribution of porosity values within the injection zone from the three type logs is presented in Figure 13.

Porosities ranged from 14.5% to 27.9% across the three type logs, with an average porosity of 21.2% +/- 6.7% standard deviation. These values align with Woodbine porosity ranges represented in published research papers.

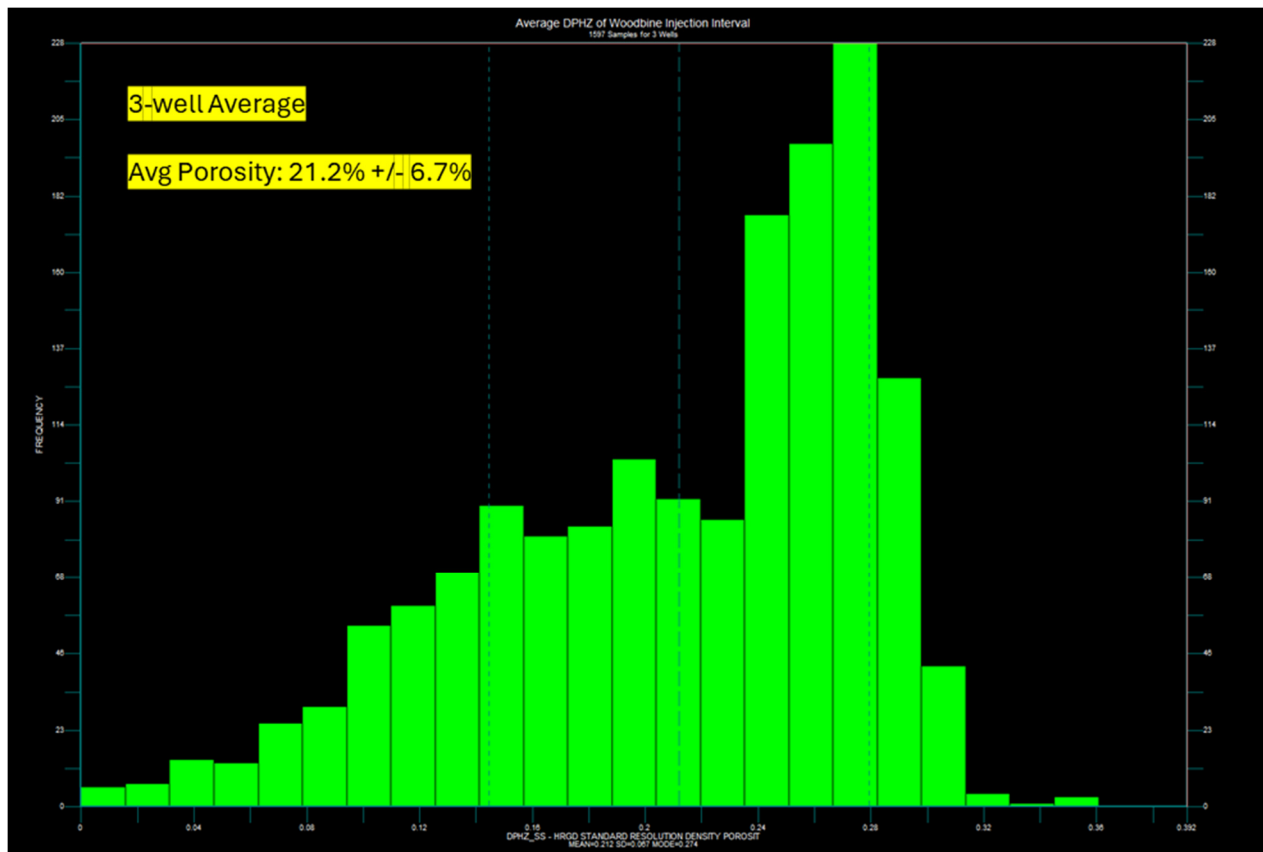

Figure 13 – Histogram showing porosity distribution from the three type logs. The average porosity of the injection zone was calculated to be 21.2% +/- 6.7% standard deviation.

Because of a lack of publicly available core data in the Woodbine formation proximal to the area of review (AOR), porosity-permeability relationships from published literature were reviewed for potential application. A crossplot by Loucks et al. (2015), shown in Figure 14, using core samples in the East Texas field, was selected to transform porosity to permeability.

The average porosity value (21.2%) was projected onto the best-fit line (dashed pink line in Figure 14) of the Loucks et al. (2015) crossplot to estimate an average permeability of 80 millidarcies (mD). Standard deviation lines (dashed gray) were drawn to bracket the best-fit line to estimate a permeability range of 2.5 mD to 1,600 mD. This permeability range aligns with the range generated

by projecting the minimum and maximum porosity range values (14.5% and 27.9%, respectively) onto the best-fit line, providing added confidence.

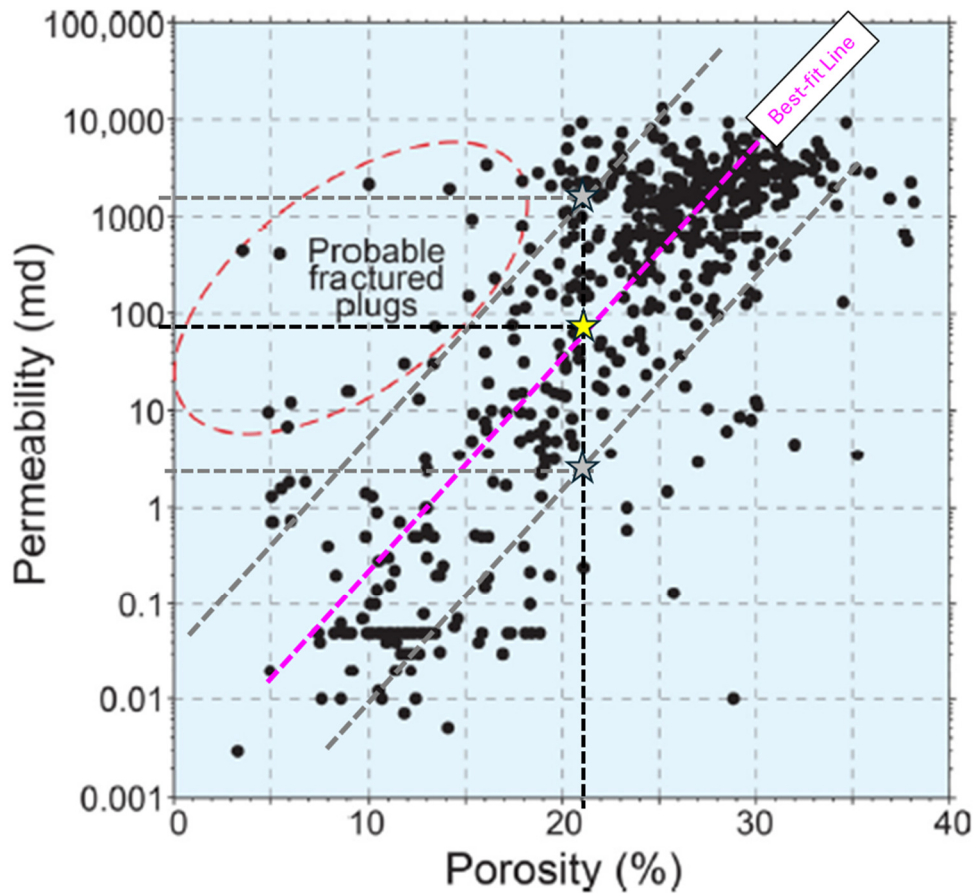

Figure 14 – Porosity versus permeability scatter plot for Woodbine sandstone samples from the East Texas Field. High- and low-end porosity range values as well as average porosity were projected onto the best-fit line (dashed pink) to estimate a permeability range and average (modified from Loucks et al., 2015).

2.7.2 Woodbine Formation Fluid

A review of formation water from the USGS National Produced Water Geochemical Database, v. 2.3 identified 18 samples with analyses collected from the Woodbine Formation in wells in Freestone County and neighboring counties (i.e., Navarro, Anderson, Henderson, and Limestone). A summary of formation fluid characteristics is presented in Table 4.

Table 4 – Produced Woodbine Formation Water Characteristics for wells in Freestone, Texas, and surrounding counties (data from USGS National Produced Waters Database, v2.3, accessed Feb. 14, 2025).

IDUSGS	API	DEPTH	PH	TDS	HCO3	Ca	Cl	Mg	Na	SO4
86291	42-001-01430	5831		85645	205	2950	51991	540	29895	265
86355	42-293-00355	2952		23644	488	464	14000	137	8481	24
86405	42-001-02207	4665	6.7	100000	281	3400	61200	850	34300	122
86410	42-001-00425		7.8		528	168	4020	19	2610	67
86429	42-001-02207		7.0	100300	186	3540	61200	523	34800	93
86430	42-001-01788	5811.5	6.3	120435	288	3920	73200	494	42268	265
86431	42-001-01788	5811.5	6.3	98079	300	3600	59640	481	33846	212
89619		4031		71138	421.30	1976.	42940.75	359.46	25033.58	204.36
90061		3020		28162	342	528	16900	171	10156	
92750		3077	7.8	13838	838.30	64.64	7696.20	34.34	5179.28	25.25
98232	42-349-00068	3300	7.90	20026.50	1232.01	95.32	11103.30	42.59	7501.57	51.71
99778			7.00	81593	305	2500	49620	375	28710	47
99779			7.02	63650	215	1930	38740	330	22330	37
99780			7.03	88835	350	2830	54050	485	31000	70
99781			7.11	79959	325	2400	48610	430	28100	60
99782			7.07	84504	360	2600	51360	410	29690	54
099783			7.85		225	185	3875	31	2320	15
100768		3583	7.10	29577		1445	14000	12	9380	
AVERAGE:			7.14	68,085	382	1,922	36,897	318	21,422	101

IDUSGS – United States Geological Society Identification

API – American Petroleum Institute

PH – potential of hydrogen

TDS – total dissolved solids

HCO3 – bicarbonate

Ca – calcium

Cl - chlorine

Mg - magnesium

Na - sodium

SO₄ - sulfate

The sampled locations contain a wide range of depths and ion concentrations with an average total dissolved solids (TDS) concentration of 68,085 parts per million (ppm). Salinity was calculated from calculating apparent water resistivity (R_{wa}) in the three type wells in conjunction with bottomhole temperature to derive a salinity range of 58,000 ppm to 75,000 ppm, with an average of 69,000 ppm. Additionally, the Texas Water Development Board (TWDB) Regional Woodbine Salinity Map shown in Figure 15 suggests an estimated salinity of 60,000 ppm to 70,000 ppm at the Aker No. 1 location. The three different methods of calculating salinity resulted in very consistent values providing confidence in their accuracy. A best-fit salinity of 69,000 ppm was selected for modeling purposes.

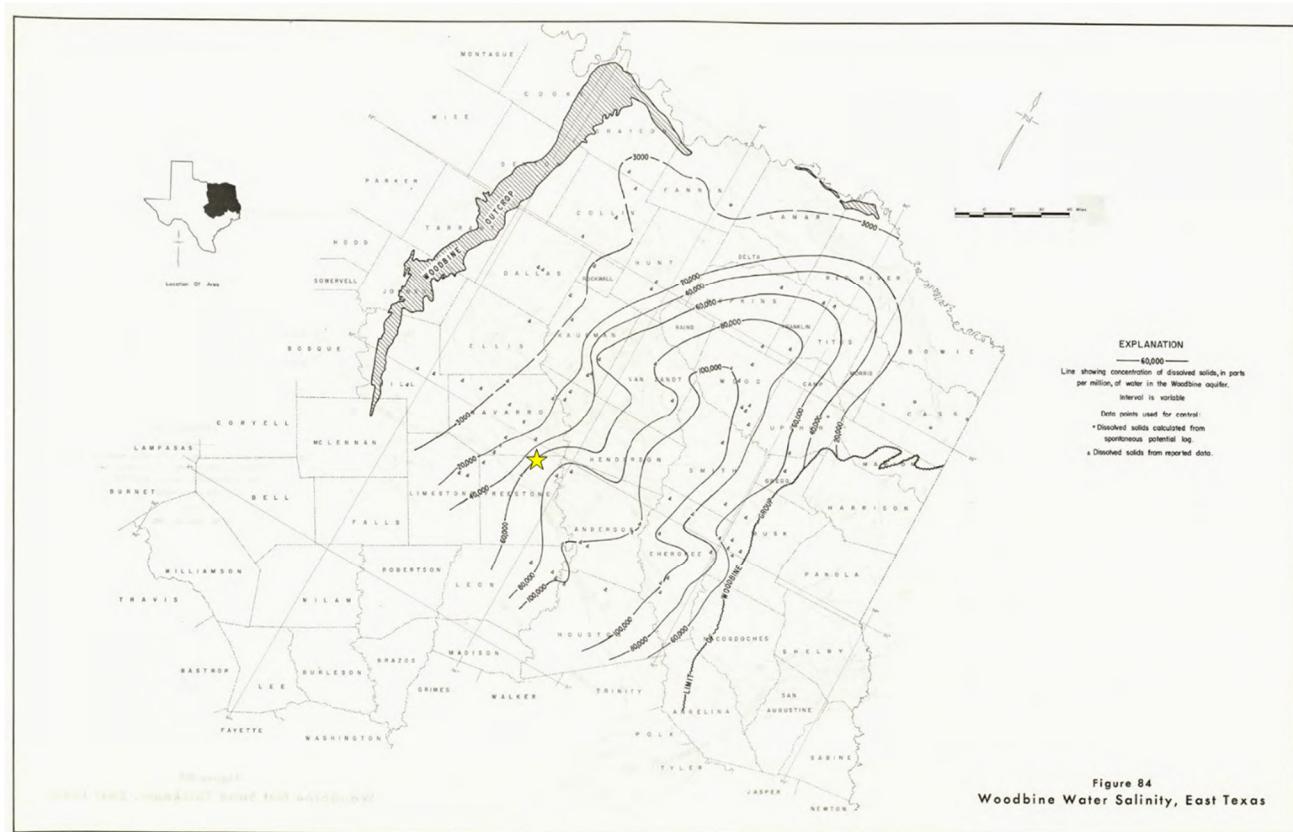

Figure 15 – Regional Woodbine Salinity Map with the location of the Aker No. 1 indicated by the yellow star, which falls within a salinity range of 60,000 ppm to 70,000 ppm (from Texas Water Development Board, Report 157).

The primary constituent of the Woodbine Formation fluid is chloride (Cl), with an average concentration of 36,897 ppm, followed by sodium (Na) with an average concentration of 21,422 ppm. Based on the data collected from offset wells, the Woodbine fluids are expected to be fully compatible with the acid gas injectate.

2.7.3 Fracture Gradient Discussion

For the Woodbine formation, a pressure gradient (PG) of 0.433 psi/ft was used in both simulation modeling and the fracture gradient (FG) calculation. This value is derived from the H-5 form for the Aker Gas Injection Well No. 01, dated November 29, 2024. The H-5 form states that an in-situ pressure gradient of 0.4125 psi/ft can be assumed at the injection well location. This value was increased to a normal PG of 0.433 psi/ft to be conservative in the simulation modeling and FG calculation. The overburden gradient (OBG) was chosen to be 1.05 psi/ft based on industry best practices when site-specific data is limited. Poisson’s ratio of 0.27 was assumed based on the literature of sandstone formations (Molina et al., 2017).

Using the variable values listed previously, an FG of 0.66 psi/ft was calculated, based on the equation shown following Table 5. A 10% safety factor was implemented, resulting in a maximum allowed

bottomhole pressure (BHP) of 0.60 psi/ft. This safety factor was set to ensure that the injection pressure never exceeds the fracture pressure of the injection zone.

The Eagle Ford shale above the Woodbine and the Maness Shale below the Woodbine are the confinement zones for injection. For both the upper and lower confining intervals, a similar PG and OBG as the injection interval were assumed. Poisson’s ratio was chosen to be 0.3 for shale and carbonate formations. Shales and carbonates tend to have higher Poisson’s ratios compared to sandstone formations (Molina et al., 2017).

Table 5 provides the inputs and results of the FG calculations for the Aker Gas Injection No. 01 well.

Table 5 – Fracture Gradient calculation inputs and results for the Aker Gas Injection No. 01 well.

Depth (ft)	Zone	Member	Overburden Gradient (psi/ft)	Pore Gradient (psi/ft)	Poisson's Ratio	Fracture Gradient (psi/ft)	90% Fracture Gradient (psi/ft)
3,477	Upper Confining	Eagle Ford	1.05	0.433	0.3	0.70	0.63
3,903	Injection	Woodbine	1.05	0.433	0.27	0.66	0.60
4,397	Lower Confining	Maness	1.05	0.433	0.3	0.70	0.63

Example Fracture Gradient Calculation for Injection Interval of the Woodbine:

$$FG = \frac{\nu}{1 - \nu} (OBG - PG) + PG$$

$$FG = \frac{0.27}{1 - 0.27} (1.05 - 0.433) + 0.433 = 0.66 \text{ psi/ft}$$

$$FG \text{ with SF} = 0.66 \times 90\% = \mathbf{0.60 \text{ psi/ft}}$$

2.8 Upper Confining Zone – Eagle Ford Shale (89 Ma to 94 Ma)

The overlying Eagle Ford shale provides upper confinement of the Woodbine injection zone. The Eagle Ford shale sits immediately below the base of the Austin Chalk, between the depths of 3,477 ft and 3,903 ft in the Aker No. 1. The Eagle Ford/Austin Chalk contact represents a major unconformity at the Turonian/Coniacian (89 manganese [Ma]) boundary (Dawson and Almon, 2010).

In the last 20 years, the Eagle Ford group has been widely recognized as a self-sourcing, self-sealing petroleum system with the advent of modern horizontal drilling of resource plays. The Eagle Ford has historically been viewed as a high-quality source rock for Cretaceous petroleum systems. The

excellent source rock character of the Eagle Ford, high organic content (2% to 6% total organic carbon), and cyclic environments of anoxic-to-oxic-to-dysaerobic allow the Eagle Ford shales to be capable of generating large quantities of hydrocarbons. These findings are consistent with other studies that concluded Eagle Ford strata are the principal source rocks for the East Texas Field (Wescott and Hood, 1994).

Regional lithofacies patterns and fossil content indicate a marginal to open marine depositional setting for the Eagle Ford Group; whereby deltas prograding southwestward delivered siliciclastic detritus to the basin. Eagle Ford strata record a mixed siliciclastic-bioclastic depositional system wherein sediments accumulated near and below a storm wave-base on a relatively shallow shelf (proximal setting), which deepened toward the south and southwest (distal setting) (Dawson and Almon, 2010). Figure 16 is a set of representative thin sections of Eagle Ford core samples showing numerous finely interstratified argillaceous, siltstone, and carbonate microfacies, which appear to record high-frequency stratigraphic cycles (Dawson, 1997).

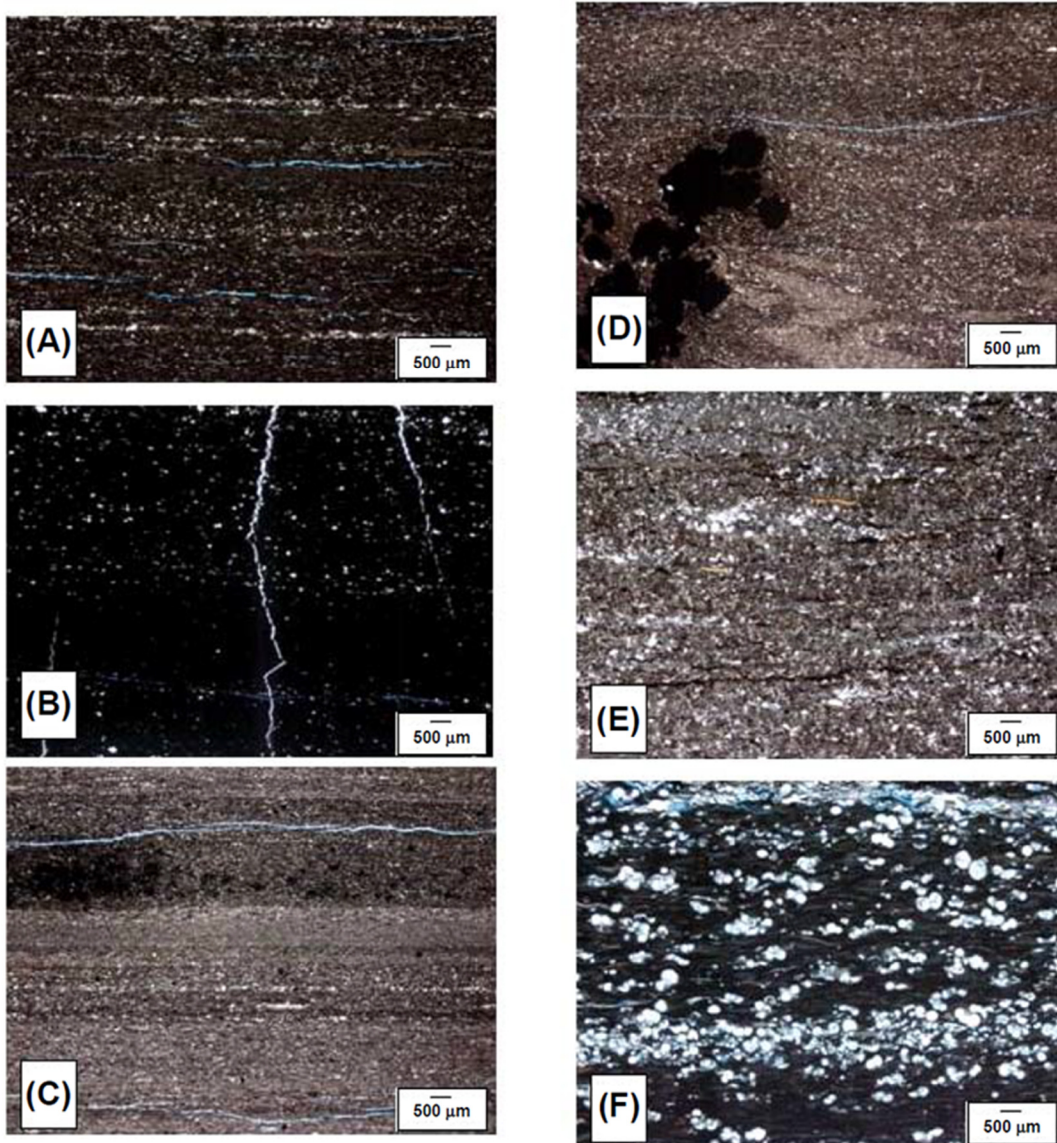

Figure 16 – Representative thin section photographs of Eagle Ford mudstones: (A) finely laminated, moderately silty, carbonaceous shale; (B) calcareous mudstone with calcite-cemented microfractures; (C) interlaminated very silty shale and argillaceous quartzose siltstone; (D) very silty mottled mudstone with authigenic pyrite nodules (lower left); (E) weakly laminated, carbonaceous and argillaceous, quartzose siltstone; and (F) finely laminated, very fossiliferous (foraminifers and phosphatic bioclasts), carbonaceous shale (from Dawson and Almon, 2010).

Figure 17 shows the mineralogical breakdown of Eagle Ford Shale from different oil and gas provinces of the present-day Gulf Coast, where the Eagle Ford is studied extensively for exploration and development purposes. Note the high carbonate (calcite)-to-shale ratio in the distal south-southwest parts of the basin (Maverick-Hawkkville-San Marcos); which makes the Eagle Ford brittle in nature and susceptible to fracturing compared to the high clay concentration in the East Texas basin that causes the Eagle Ford to have more ductile characteristics similar to typical clastic shales.

Table 5 numerically lists the approximate percentage of the four dominant constituents presented in Figure 17.

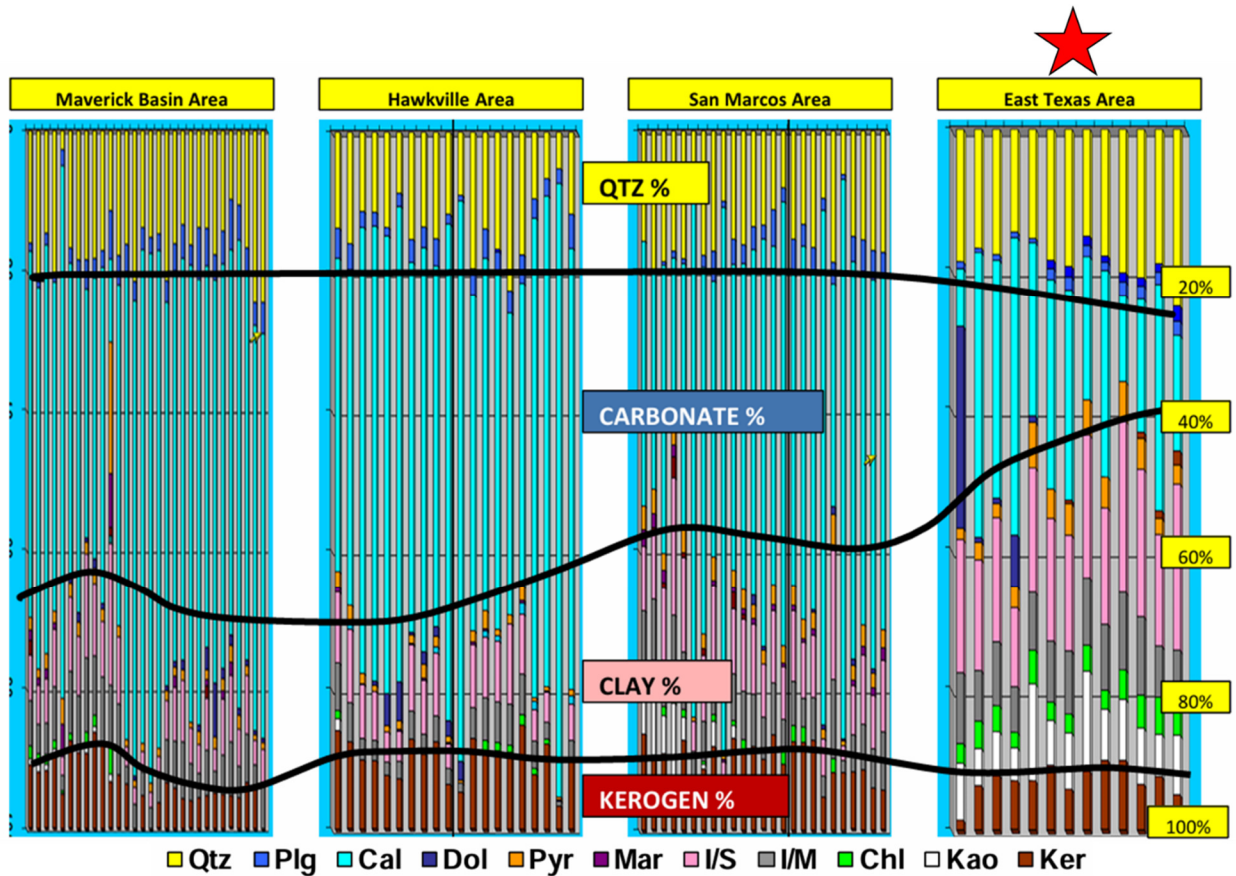

Figure 17 – Representative mineralogical constituents of Eagle Ford shale across different oil and gas regions (Stoneburner, 2014).

Table 6 – Numerical approximations of Eagle Ford shale mineral constituents (values approximated from Stoneburner, 2014).

Eagle Ford Shale (UCZ)	
Mineral Constituent	% Framework (by volume)
Clays	50%
Calcite	20%
Quartz	20%
Kerogen	10%

The thickness of the Eagle Ford shale ranges from 372 ft to 426 ft, with an average thickness of 412 ft across the modeled plume area. An isochore map of the UCZ is presented in Figure 18, which shows a general trend of thickening to the east and a local maximum thickness at the Aker No. 1 location.

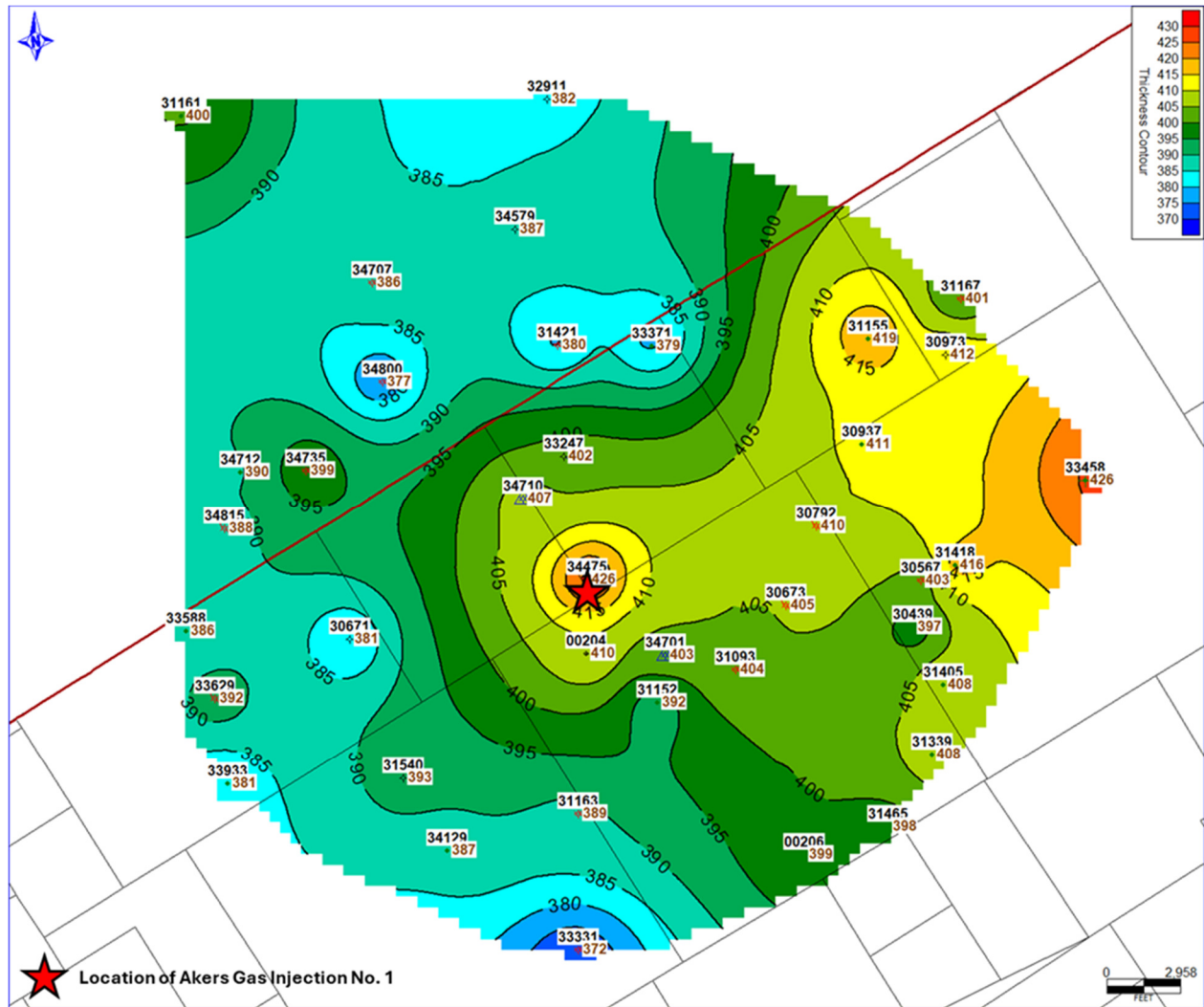

Figure 18 – Isochore map of the Eagle Ford shale, upper confining zone (UCZ).

Without publicly available core data, white paper research was relied on for porosity and permeability estimates of the Eagle Ford confining shale. Ramirez et al. (2016) found Eagle Ford porosities ranged between 0.3% to 10.3%, with an average porosity of 1.4%. A regional Eagle Ford study by Przywara et al. (2011) calculated an average Eagle Ford permeability of 0.0004 mD across 200+ samples. These average porosity and permeability values are in line with other public research papers.

2.9 Lower Confining Zone – Maness Shale (96 Ma to 97 Ma)

The Lower Cenomanian Maness Shale is a clay-rich mudrock originally identified in the East Texas Field, lying between the Woodbine and Buda Limestone, that has been correlated to the basal Lower Eagle Ford in the vicinity of the San Marcos Arch (Patterson and Denne, 2019). While the Maness Shale has the properties to serve as the sole, effective lower confinement, the Buda Limestone provides additional, secondary confinement.

The Maness Shale is black to dark gray, massive to indistinctly laminated mudstone, with sparse to nonexistent foraminiferal laminae (Patterson and Denne, 2019). Core samples of the Maness Shale have revealed encased ash beds that are typical of the interval, which has higher clay content than its shallower equivalent, the Eagle Ford Shale. According to X-ray Diffraction (XRD) mineralogy data published by Patterson and Denne (2019), the constituents of the Maness Shale from order of highest occurrence by volume to lowest include clays, silica, carbonate-calcite, feldspar-micas, and pyrite; specific constituent volumes from core samples can be found in Table 7. The predominant clay type is Illite and Mica (~82%), followed by Kaolinite (~15%), with minimal contribution from Smectite (< 3%).

Table 7 – Mineralogy by XRD of Maness Shale samples (Patterson and Denne, 2019).

Maness Shale (LCZ)	
Mineral Constituent	% Framework (by weight)
Clays	49%
Carbonate-Calcite	22%
Silica	18%
Feldspar-Micas	6%
Pyrite	4%
Ankerite	1%

The thickness of the Maness Shale ranges from 37 ft to 84 ft, with an average thickness of 61 ft across the modeled plume area. An isopach map of the LCZ is presented in Figure 19, which shows a strong trend of thickening to the east; the Maness Shale has a thickness of 60 ft at the Aker No. 1 location.

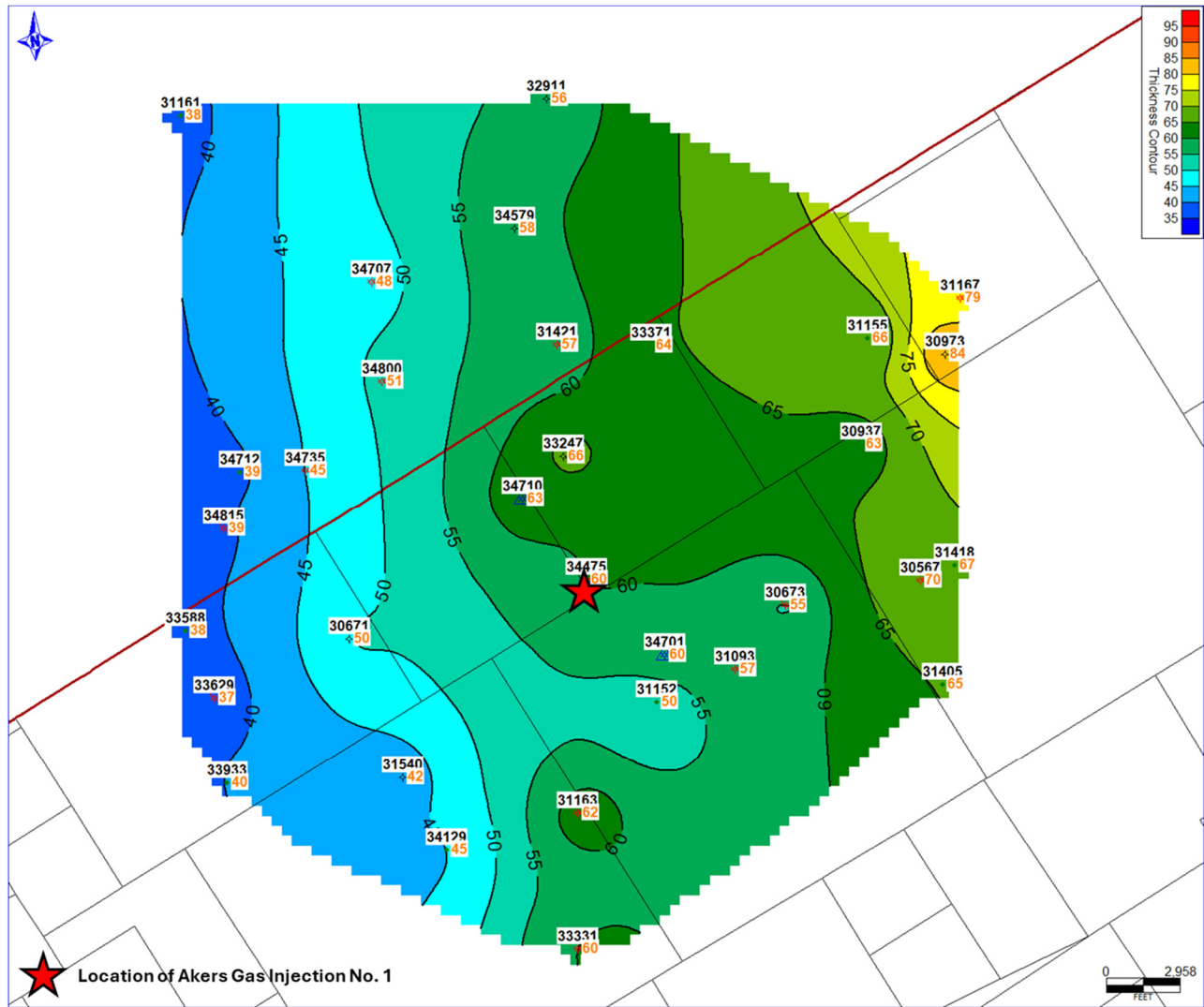

Figure 19 – Isochore map of the Maness shale, lower confining zone (LCZ).

Without publicly available core data, white paper research was relied on for porosity and permeability estimates of the Maness Shale. Because the Maness Shale is correlative to the basal Eagle Ford shale, the same 1.4% average porosity and 0.0004 mD average permeability values from white paper research were assumed for the lower confining shale. Additional confinement is provided from the Buda Limestone with an average computed porosity of 1.5%. The tight nature of the carbonate unit and the capillary pressure contrast with the encasing shales is more than sufficient for preventing fluid migration.

2.9.1 Injection and Confinement Summary

The modeled lithologic and petrophysical characteristics of the Woodbine Formation at the Aker No. 1 location agree with findings of regionally published literature and suggest that the injection reservoir provides sufficient pore space required to store the modeled and proposed injection fluids.

The Eagle Ford shale is anticipated to exhibit low permeability throughout the gross overlying section, with sufficient thickness and lateral continuity to serve as the UCZ. Beneath the injection interval, the low permeability, low porosity Maness Shale serves as the LCZ.

Regionally published core data and white paper research were integrated with regional open-hole log data to approximate rock properties for the injection and confinement zones. Site-specific, modern log and historical pressure data at the injection and monitor well locations were also integrated into the reservoir plume modeling to further validate the rock properties from regional data sources. The modeling parameters and methodology are described in greater detail in *Sections 2.14 and 2.15*.

2.10 Local Structure

The Aker No. 1 well is located along the western flank of the East Texas Basin, immediately east of the regional Mexia-Talco Fault System. A TVD subsea (TVDSS) structure map on the top of the Woodbine Formation is provided in Figure 20. The map illustrates the gentle southeastern bed dip (0.7° to 1.1°) of the Woodbine Formation at the Aker No. 1 location. No faulting in the area was observed from the local subsurface data, nor were any regional faults found within the AOR from the publicly available structure maps that were reviewed.

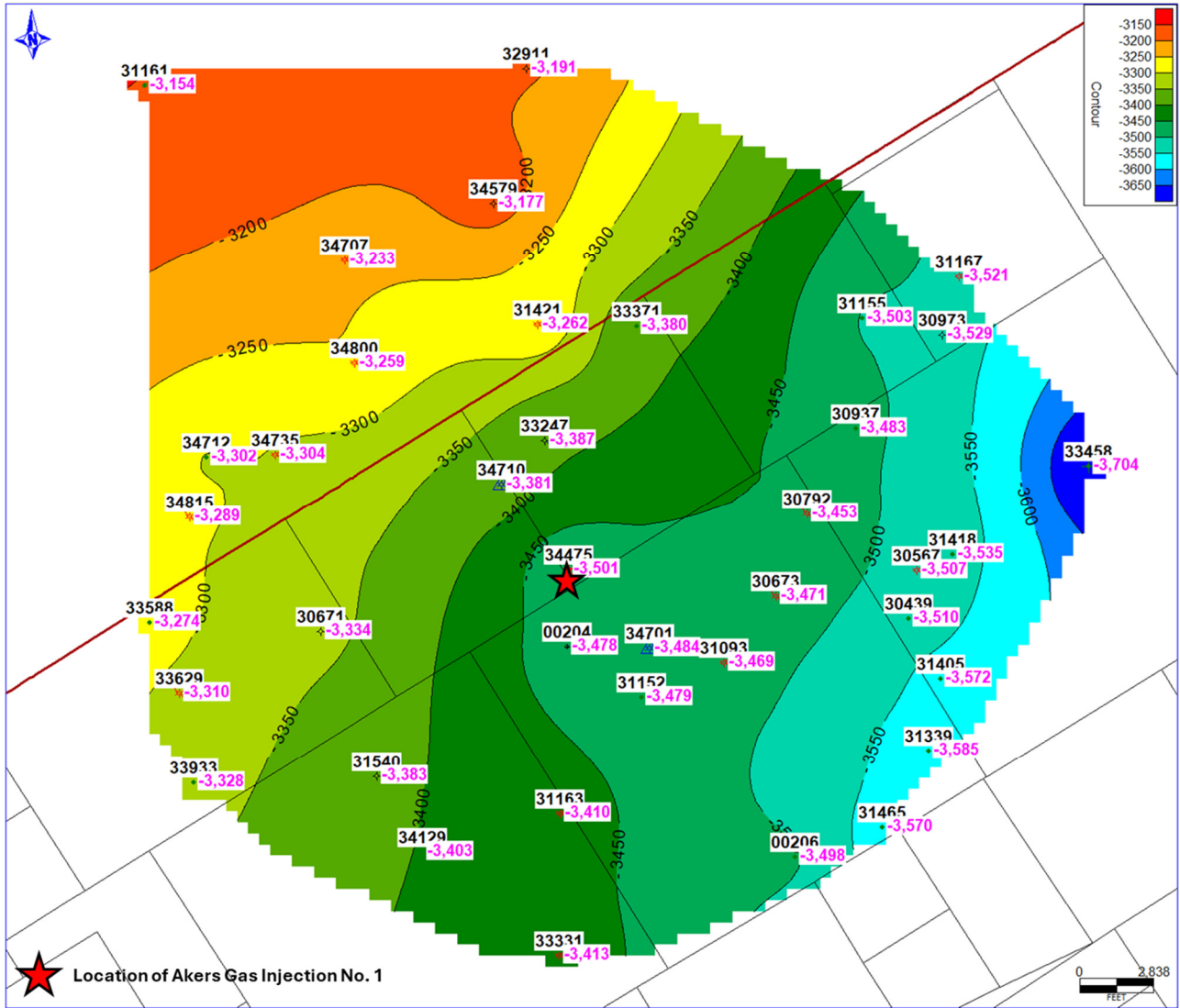

Figure 20 – TVD subsea structure map of the Top of the Woodbine injection zone (IZ).

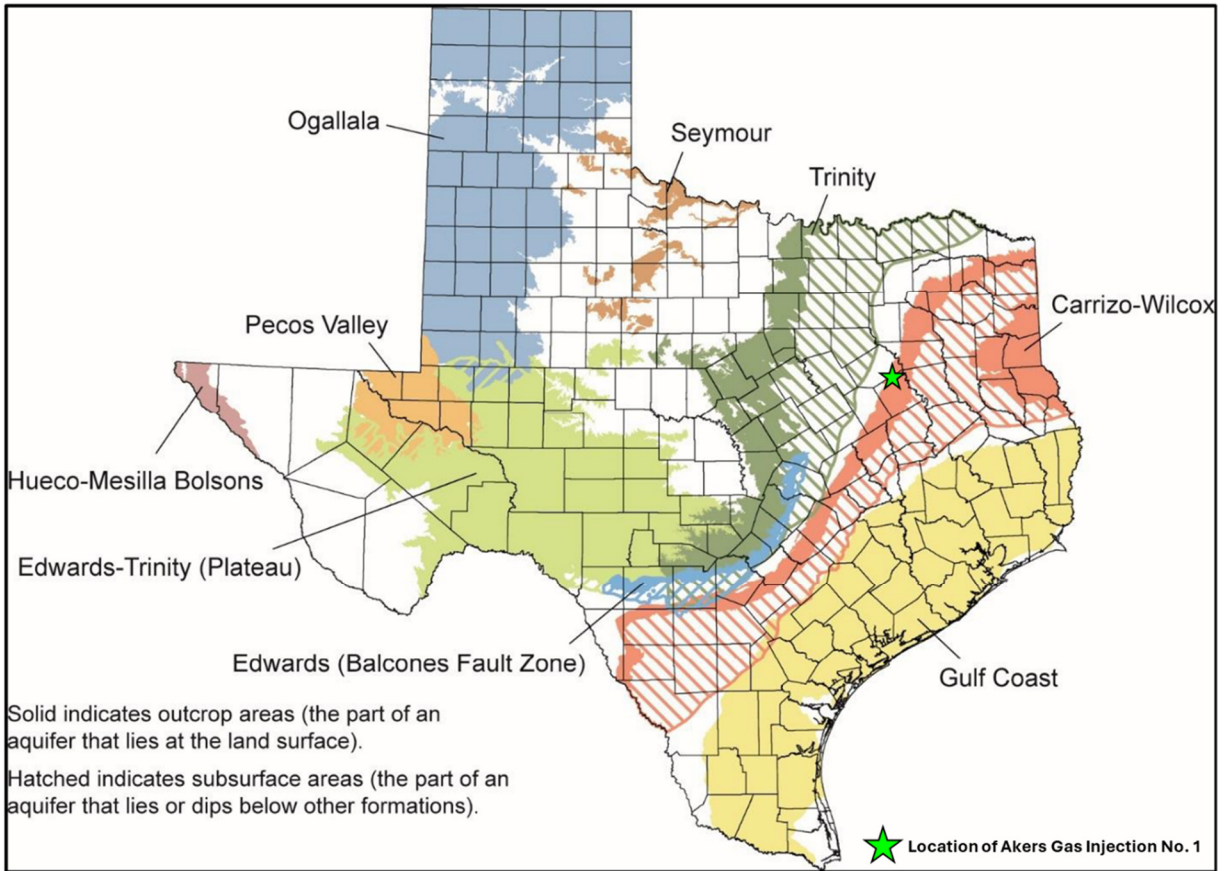

Figure 22 – Map showing the location of the Aker No. 1 in relation to the major aquifers of Texas (modified from Bruun et al., 2016).

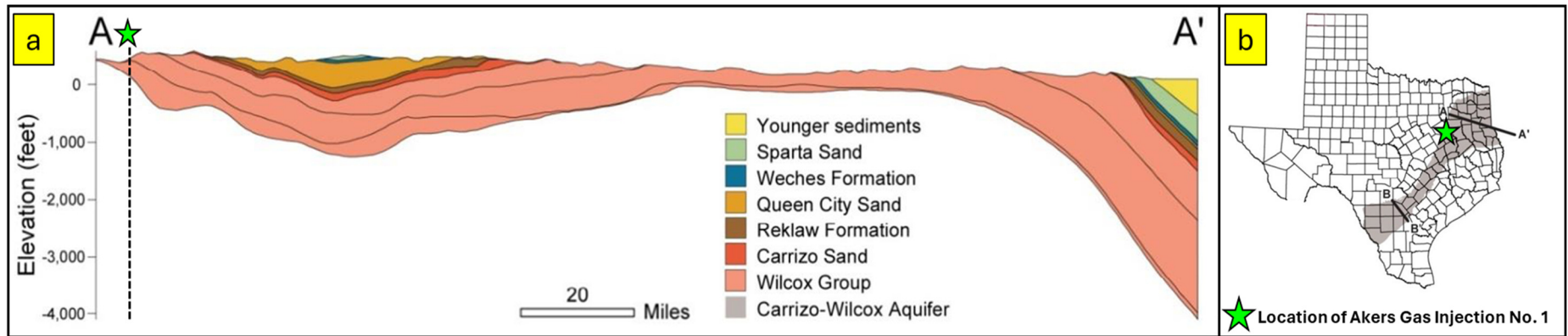

Figure 23 – (a) Structural cross section of the Carrizo-Wilcox Aquifer and overlying strata with the location of the Aker No. 1 projected onto the cross section, and (b) reference map showing the location of the cross section line and Aker No. 1 (modified from Bruun et al., 2016).

The water quality of the aquifer varies aerially as well as with depth, but tends to be brackish to saline in downdip regions of the aquifer and within deeper stratigraphic intervals. According to the TDS map of the Carrizo-Wilcox aquifer, shown in Figure 24, the TDS are approximately 1 milligram per liter (mg/L) to 1,000 mg/L near the Aker No. 1 location; however, concentrations between 1,000 mg/L to 3,000 mg/L are observed in the northeastern corner of Freestone County as well as the central portion of the Freestone-Limestone County border. Carrizo-Wilcox groundwater tends to be hard in unconfined areas and is generally softer where confined by the overlying Reklaw Formation. The primary recharge mechanism is surface recharge from precipitation, but groundwater also interacts with local creeks, streams, and rivers that flow through unconfined portions of the aquifer. This interaction can result in discharge or recharge of groundwater depending on the water level of the aquifer relative to the stage of the river.

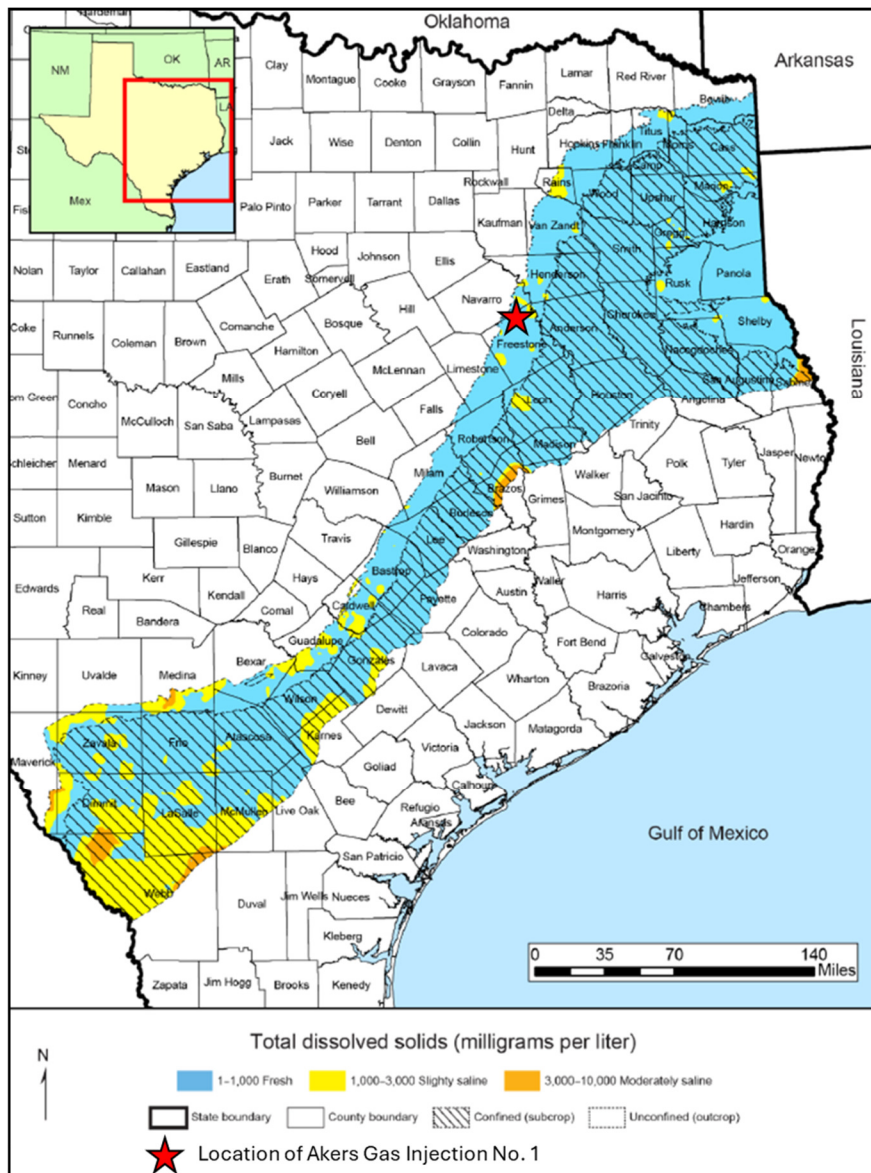

Figure 24 – Total Dissolved Solids (TDS) Map of the Carrizo-Wilcox Aquifer System, showing the location of the Aker No. 1, which is in a predominantly fresh water (< 1,000 mg/L) region.

2.12 Surface Water Hydrology

There are several surface water bodies in Freestone and Navarro Counties near the Aker Gas Plant. These surface water bodies include the Richland-Chambers Reservoir, Fairfield Lake, and the Trinity River.

2.12.1 Richland-Chambers Reservoir

The Richland-Chambers Reservoir is located 3.5 mi north of the Aker No. 1 location. The lake has a surface area of 41,356 acres and a maximum depth of 75 ft according to Texas Parks and Wildlife. The reservoir was formed by the impoundment of Richland Creek and Chambers Creek east-southeast of the town of Corsicana in 1987. The lake's primary purpose is as a water supply reservoir, with Tarrant Regional Water District (TRWD) having built the reservoir, retaining most of the water rights; the City of Corsicana also holds the rights to a large portion of water from the reservoir with the right to purchase more. The lake is also used for fishing and recreational purposes.

2.12.2 Fairfield Lake

Fairfield Lake is located 11.5 mi southeast of the Aker No. 1 location and covers a surface area of approximately 2,159 acres. Until 2023, this area was a Texas State Park, but it was closed after several attempts were made by the State of Texas to purchase the park from a Dallas-based real estate developer. The lake is on Big Brown Creek, which is a tributary of the Trinity River that runs roughly north-south approximately 4 mi east of Fairfield Lake. The lake has historically been used for industrial purposes, specifically thermal-electric power generation, since the authorization of a large dam to impound 50,600-acre/feet of water was issued to TXU Electric Company on May 9, 1968.

2.12.3 Trinity River

The Trinity River runs north-south roughly 12 mi east of the Aker No. 1 location. The river is approximately 710 mi long, which is the longest river with a watershed entirely in the State of Texas. It rises in the far north part of Texas, just a few miles south of the Red River and flows southeast from Dallas across a fertile floodplain and the pine forests of eastern Texas. The river empties into Trinity Bay, an arm of Galveston Bay that is an inlet of the Gulf of Mexico.

2.13 Base of USDW Determination

The TRRC's Groundwater Advisory Unit (GAU) identified the base of usable-quality groundwater at a depth of 425 ft in the Aker No. 1 well, with the base of the Underground Sources of Drinking Water (USDW) at 3,150 ft. Approximately 3,480 ft of shales, sands, and carbonates separate the base of freshwater from the injection interval; 755 ft of shales, sands and carbonates separate the lowermost USDW from the Woodbine injection interval, including the regionally continuous and clay-rich Eagle Ford shale (UCZ), which has an average thickness of > 400 ft in the AOR. A copy of

the GAU's Groundwater Protection Determination letter issued by the TRRC as part of the Class II permitting process for the Aker No. 1 well is shown in Figure 25.

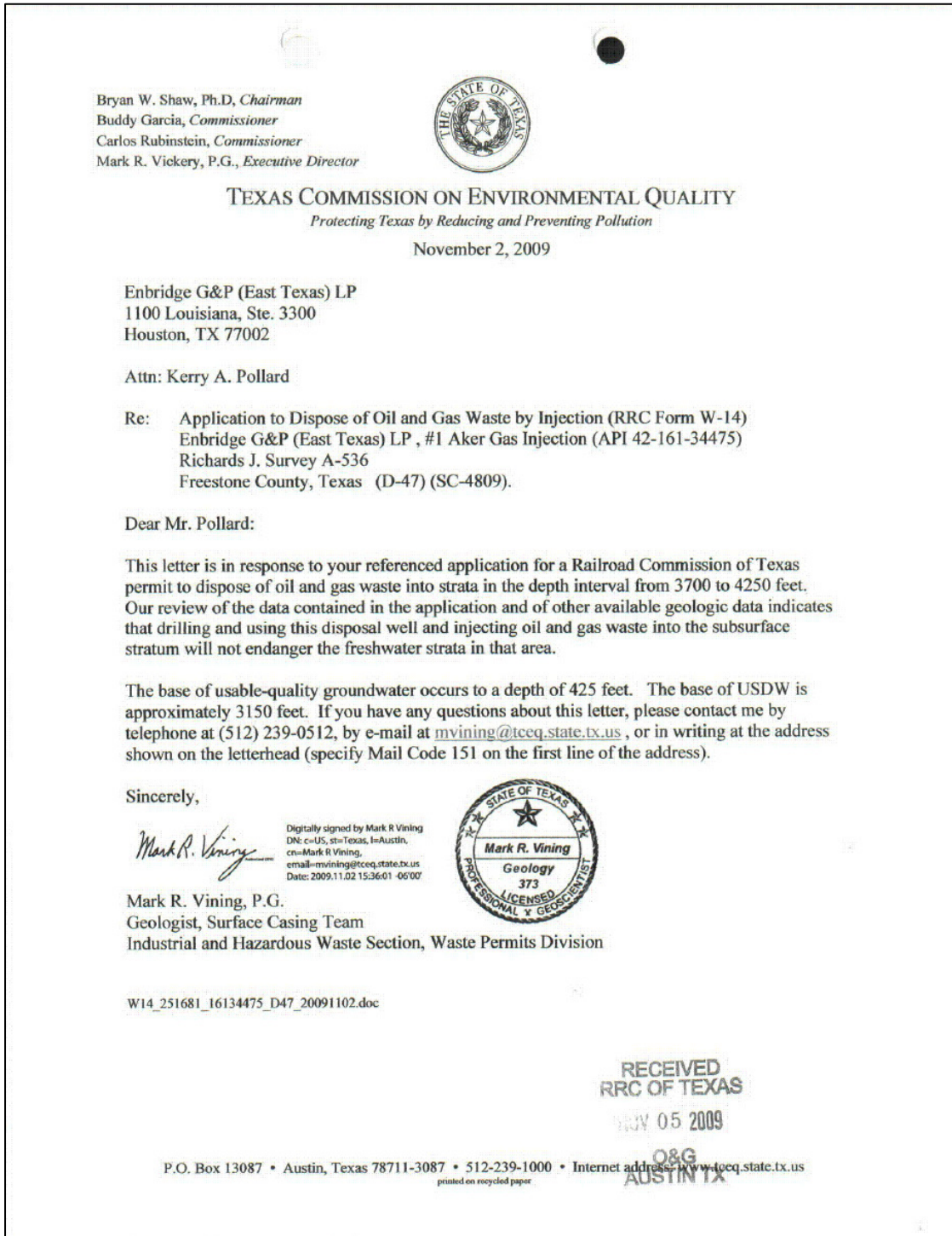

Figure 25 – Groundwater and USDW letter issued as part of the Aker No. 1 Class II permit (accessed from Texas Railroad Commission, February 25, 2025).

2.14 Reservoir Characterization Modeling

Dynamic plume modeling was performed in Rock Flow Dynamic's (RFD) tNavigator version 24.4 (tNav). The model was created using a structure contour map of the top of the Woodbine injection interval and a type log of the injection well to support the permitting of the Aker No. 1 for acid gas injection. The modeling predicts well injectivity, pressure response, and acid gas plume migration. The target injection zone is the Woodbine formation, located at a depth between 3,903 ft to 4,337 ft (TVD).

tNavigator is an advanced reservoir simulation software that seamlessly integrates essential tools for dynamic simulation, data analysis, and reservoir optimization within a single environment. Renowned for its capabilities in modeling compositional fluid flow in both conventional and unconventional reservoirs, its powerful simulator effectively models complex chemical and physical processes, making it a valuable tool for applications like Carbon Capture and Storage (CCS) and acid gas injection.

2.14.1 Reservoir Modeling – Woodbine

The Woodbine Formation is the target formation for Aker No. 1 well. The Petra software package was used to construct a geological model for this target formation. Within Petra, formation top contours were generated for the Woodbine Formation and subsequently brought into tNavigator to depict the geological structure.

Porosity and permeability were determined through analysis of the injector well type log and an extensive literature review (Loucks et al., 2015). The porosity was taken from the type log of the injector well. Each sand package was assigned an average porosity value. Because of a lack of permeability data, the permeability was used as the main variable for history matching the historical injection and pressure data of the injector well, as well as matching plume size based on when the acid gas plume contacted the monitoring well to the north. Permeability values used in the model fall into the range expected to be found in the injection interval. Both the porosity and permeability estimates from the type log and literature are incorporated into the model with the assumption that they exhibit lateral homogeneity for the given layer.

The reservoir is assumed to be at hydrostatic equilibrium. The well is perforated at depths according to the W-2 Completion Report. Each of the three sand packages within the injection interval has an assigned porosity and permeability value based on the type log and history matched permeability, backed by literature (Loucks et al., 2015). The modeled injection interval exhibits an average permeability of 300 mD and an average porosity of 21.2%. These values fall into the range expected back on the previously mentioned literature review. An infinite-acting reservoir has been created to simulate the boundary conditions.

The acid gas injectate is composed of CO₂, H₂S, and trace components of hydrocarbons (C1 – C7), as shown in Table 7. The modeled composition considers CO₂ and H₂S. The gas composition for the proposed injection period remains constant.

Table 8 – Modeled Initial Gas Composition.

Component	Expected Composition (mol %)	Modeled Composition (mol %)
Carbon Dioxide (CO ₂)	98.0	98.0
Hydrogen Sulfide (H ₂ S)	2.0	2.0
Nitrogen and C ₁ – C ₇	<1.0	0.0

Core data from the literature review (Holtz, 2005) was used to determine residual gas saturation and relative permeability curves between carbon dioxide and the connate brine from analogous formations to the Woodbine sandstones (Bachu, 2013). Relative permeability curves were created using the Corey-Brooks method. The key inputs used in the model are provided in Table 8. The relative permeability curves used for the tNavigator model are shown in Figure 26.

Table 9 – Key Inputs to Reservoir Model, Woodbine.

Parameter	Value
Corey exponent, brine	3.0
Corey exponent, gas	2.0
Irreducible brine saturation	60%
Gas permeability at irreducible brine saturation	20%
Maximum residual gas saturation	30%

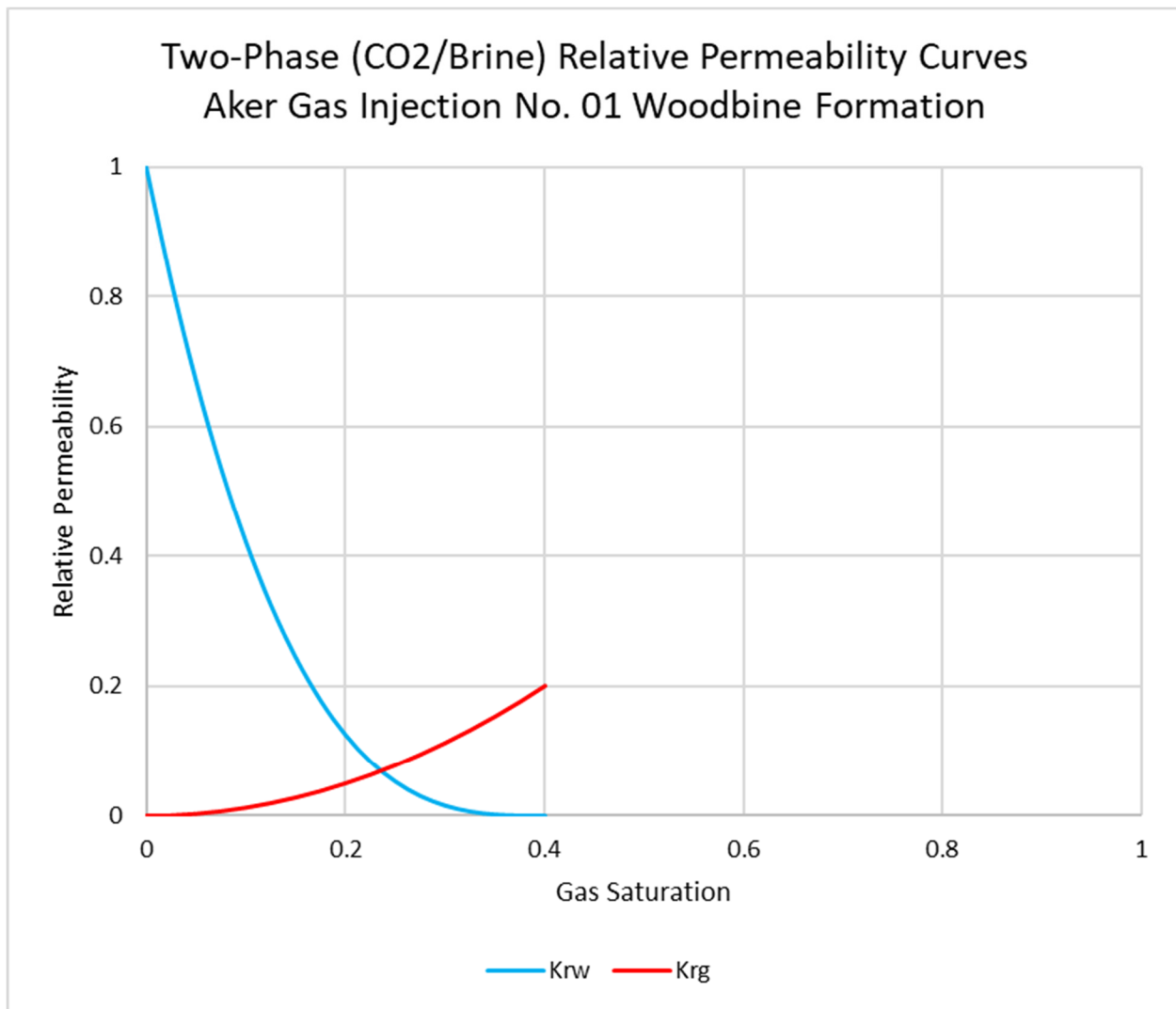

Figure 26 – Two-Phase Relative Permeability Curves Used in the tNavigator Model.

The grid contains 151 blocks in the x-direction (east to west) and 151 blocks in the y-direction (north to south), resulting in a total of 22,801 grid blocks per layer. Each grid block spans dimensions of 250 ft by 250 ft. This configuration yields a grid size measuring 37,750 ft by 37,750 ft, equating to a little more than 51 square miles in area.

In the model, each layer is characterized by homogeneous porosity and permeability values. These values are derived from a porosity log of the Aker No. 1 well and literature review (Loucks et al., 2015). The intervals of sand are assigned to the values from the porosity log and permeability values based on the history match. Values of 5% porosity and 0.001 mD permeability are assigned to shale intervals within the gross injection zone. Upscaled porosity and permeability values from the type log are used to define each layer in the model. These layers are implemented into the model and grouped as “packages,” as seen in Table 10. The model encompasses the entire injection interval, with the top layer being the top of the Woodbine and the bottom layer being the base of the Woodbine. A total of 29 layers are modeled. Sand layers have a thickness of 5 ft.

Table 10 – tNavigator Model Layer Package Properties.

Contour Package	No. of Layers	Top (TVD ft)	Thickness (ft)	Perm. (mD)	Porosity
Sand 1	9	3,903.0	45.0	300	0.20
Shale 1	2	3,948.0	108.0	0.001	0.05
Sand 2	5	4,056.0	26.5	300	0.16
Shale 2	2	4,081.5	62.5	0.001	0.05
Sand 3	8	4,144.0	40.0	300	0.25
Shale 3	3	4,184.0	15.5	0.001	0.05

2.15 Simulation Modeling

The primary objectives of the model simulations were as follows:

1. Estimate the maximum areal extent and density drift of the gas plume after injection.
2. Determine the ability of the target formation to handle the required injection rate without fracturing the injection zone.
3. Assess the likelihood of the gas plume migrating into potential leak pathways.

The reservoir is assumed to be an aquifer filled with 100% brine. The salinity of the formation is estimated to be 69,000 ppm, based on log analysis of the injector and two offset monitoring wells (API #: 42-161-34475, 42-161-34710, and 42-161-34701) and typical for the region and formation (Texas Water Development Board, 1972). The formation temperature gradient is assumed to be 2.7 degrees Fahrenheit (°F) per 100 ft, with an ambient surface temperature of 70°F, and is based on the bottomhole temperature reading at the injector and two offset monitoring wells (API #: 42-161-34475, 42-161-34710, and 42-161-34701). The acid gas stream is primarily composed of CO₂ and H₂S, as stated previously. A literature review was conducted to find a range of porosity and permeability values of the Woodbine that it would be reasonable to assume when conducting the history match (Loucks et al., 2015). As previously mentioned, cores that most closely represent the Woodbine sandstone in this region were identified from literature, and the Corey-Brooks equations were used to develop the curves (Bachu, 2013). A low and conservative residual gas saturation based on the cores from the literature review was then used to estimate the size of the plume (Holtz, 2005).

Because of a lack of permeability data, literature was relied upon to match historical injection and pressure data by adjusting the permeability within the range of possibilities. To achieve this lack of data, the historical gas injection rate was controlled, while historical wellhead pressure (WHP) was variable. After the model was built and all fluid properties listed previously were input, realizations were run, thereby changing permeability until the wellhead pressure was matched to

the best ability of the model. The model had to also take plume migration into account. It is known that the acid gas plume has reached the monitoring well to the north. Permeability within the sand packages were adjusted to best represent the acid gas plume coming into contact the northern monitoring well by time 0 (end of historical injection).

The model is initialized with a reference pressure of 1,691 psig at a subsea depth of 3,500 ft. This pressure, when a Kelly Bushing (KB) elevation of 406 ft is considered, correlates to a gradient of 0.433 psi/ft. Based on the latest H-5 form, dated November 29, 2024, the BHP gradient was calculated to be 0.4125 psi/ft at the Aker Monitor Well No. 02. The choice to use the freshwater gradient of 0.433 psi/ft as the in-situ reservoir pressure gradient was made to be a conservative estimate of the reservoir pressure. The reservoir pressure is directly correlated, along with injection rate, to the surface injection pressure. The FG of the injection zone was estimated to be 0.66 psi/ft, using Eaton's method. A 10% safety factor was then applied to this number, placing the maximum BHP allowed in the model at 0.60 psi/ft, which is equivalent to 2,324 psig at the top of the Woodbine injection interval. The maximum allowable surface injection pressure (MASIP) is 1,850 psig. By using an in-situ reservoir pressure gradient of 0.433 psi/ft, a conservative estimate of wellhead pressure is output during injection.

The model, which began in April 2012, runs for 49.667 years, comprising 12.667 years of historical injection and 12 years of anticipated injection, and is then succeeded by 25 years of density drift. Throughout the historical 12.667-year injection period, a variable injection rate is injected based on the reported monthly injection from the annually submitted H-10 forms. Then, a maximum rate of 9 MMscf/d is injected for 12 years of anticipated injection, yielding the largest estimate of the plume size. After the 24.667-year injection period, when Aker No. 1 ceases injection, the density drift of the plume continues until the plume stabilizes 25 years later. The maximum plume extent during the 24.667-year injection period is shown in Figure 27. The final extent after 25 years of density drift after injection ceases is shown in Figure 28.

The cross-sectional view of the Aker No. 1 shows the extent of the Woodbine plume from a side-view angle, cutting through the formation at the wellbore. Figure 29 shows the maximum plume extent during the 24.667-year injection period. During this time, gas is injected into the permeable layers of the formation and travels predominantly laterally. Figure 30 shows the final extent of the plume after 25 years of migration. At this point in time, the effects of residual gas saturation and migration caused by density drift are clearly shown. At least 25% of the injected gas that travels into each grid cell is residually trapped as the gas travels mostly vertically, because the gas is less dense than the formation brine, until an impermeable layer is reached. Because of the dense nature of the formation brine, the plume migrates vertically upward and less laterally. Both figures are shown in a west-east view.

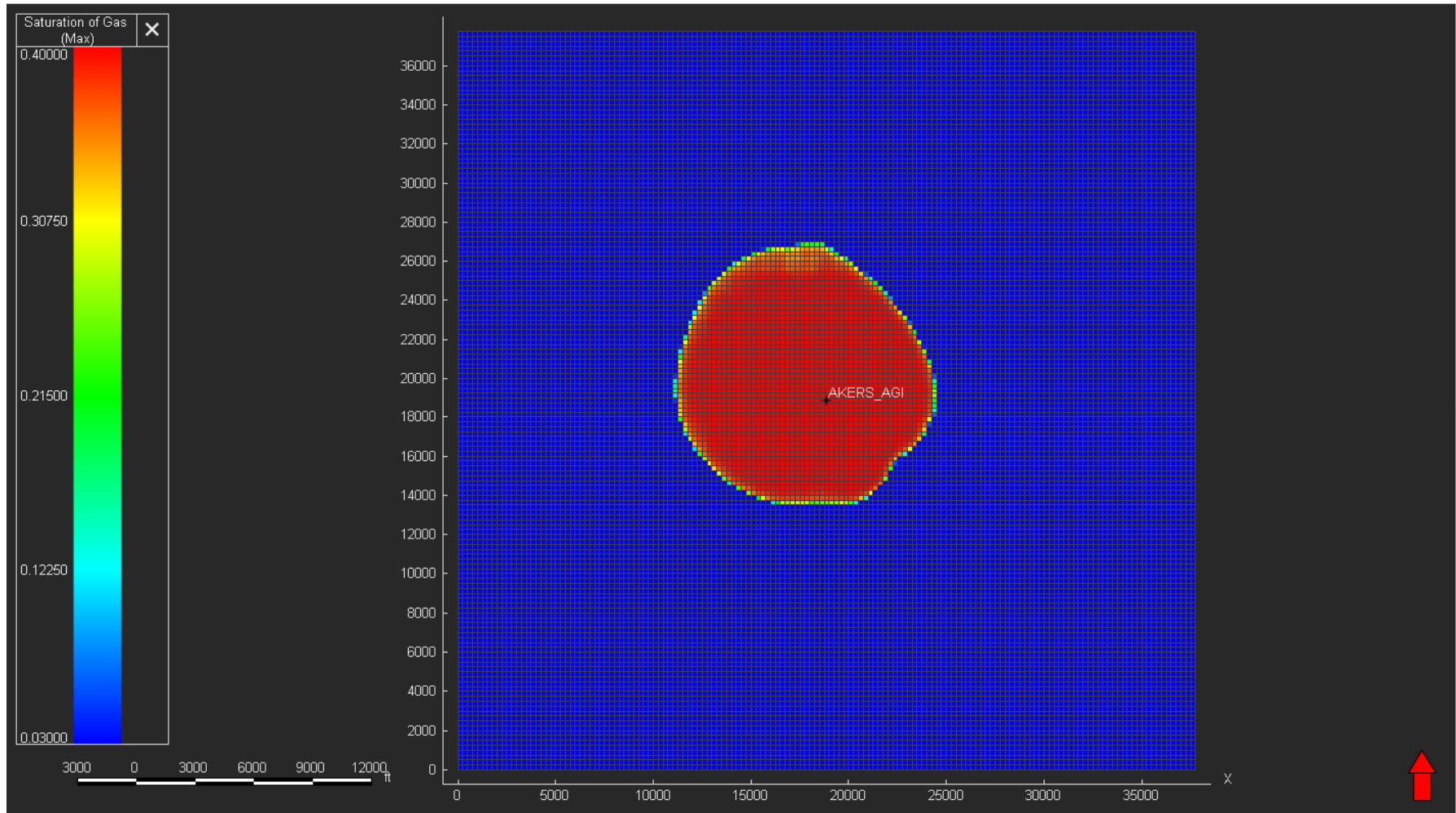

Figure 27 – Areal View of Woodbine Gas Saturation Plume at Shut-in (End of Injection).

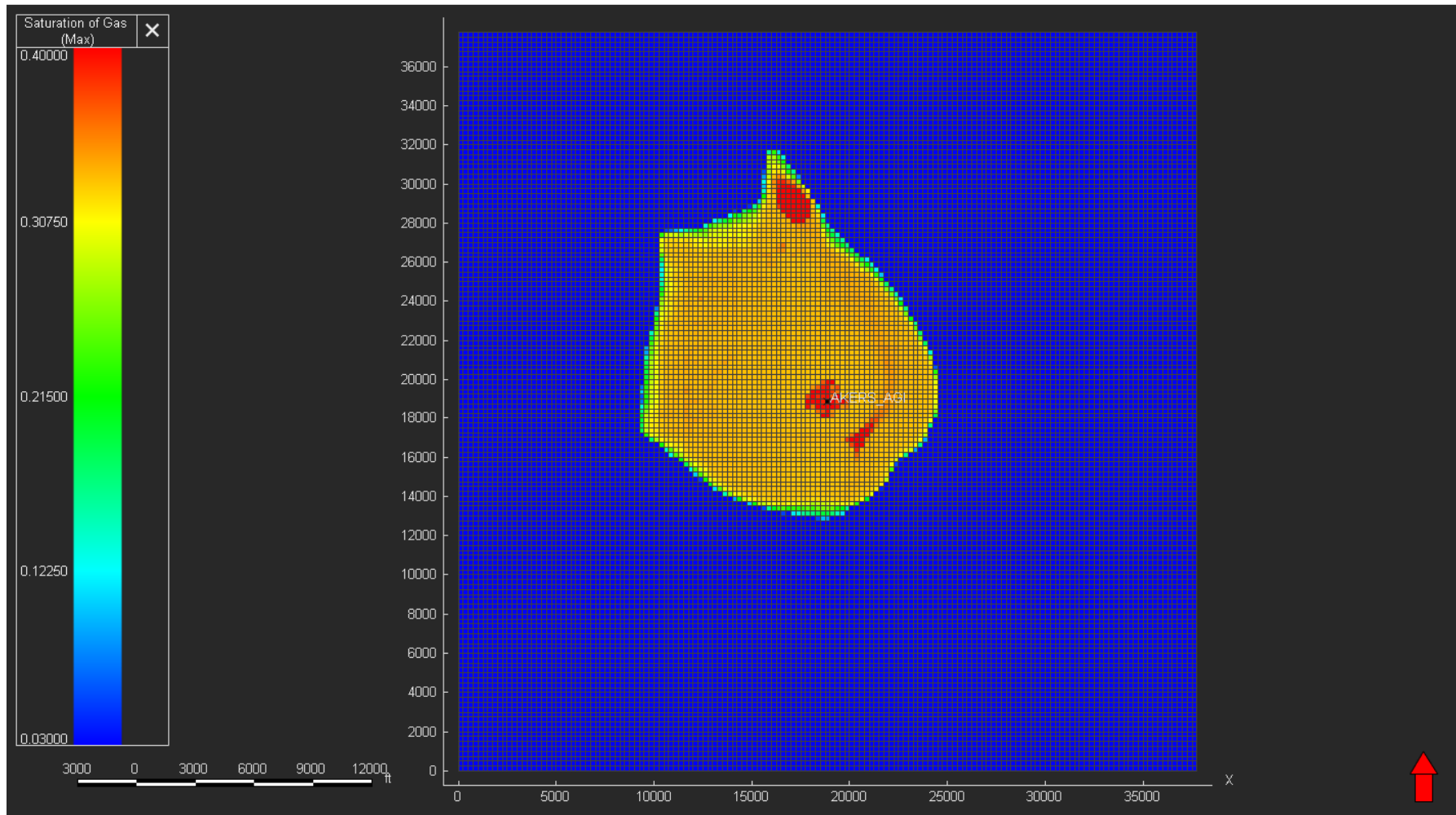

Figure 28 – Areal View of Woodbine Saturation Plume at 25 Years After Shut-in (Stabilized).

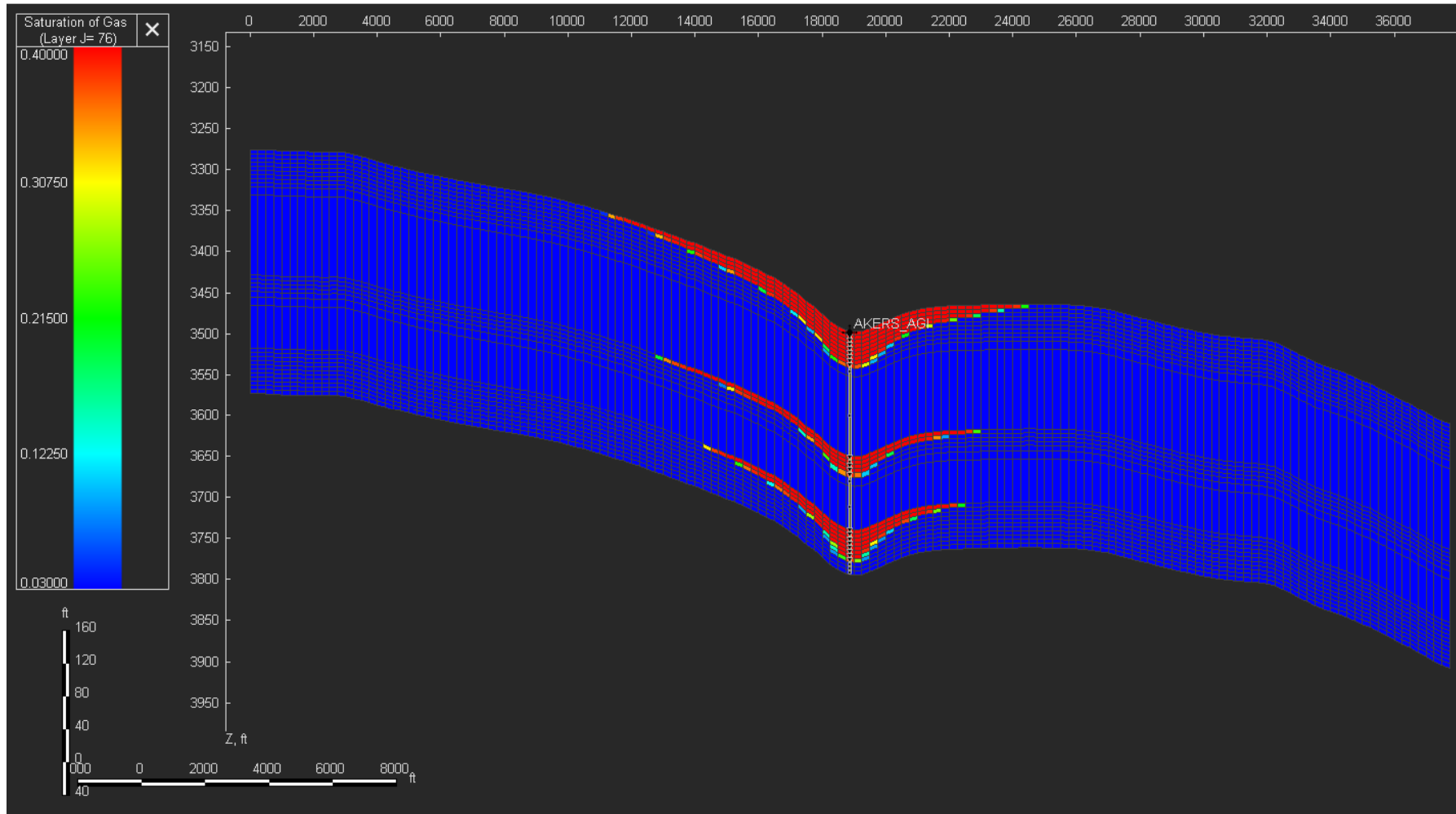

Figure 29 – West-East Cross-Sectional View of Woodbine Gas Saturation Plume at Shut-in (End of Injection).

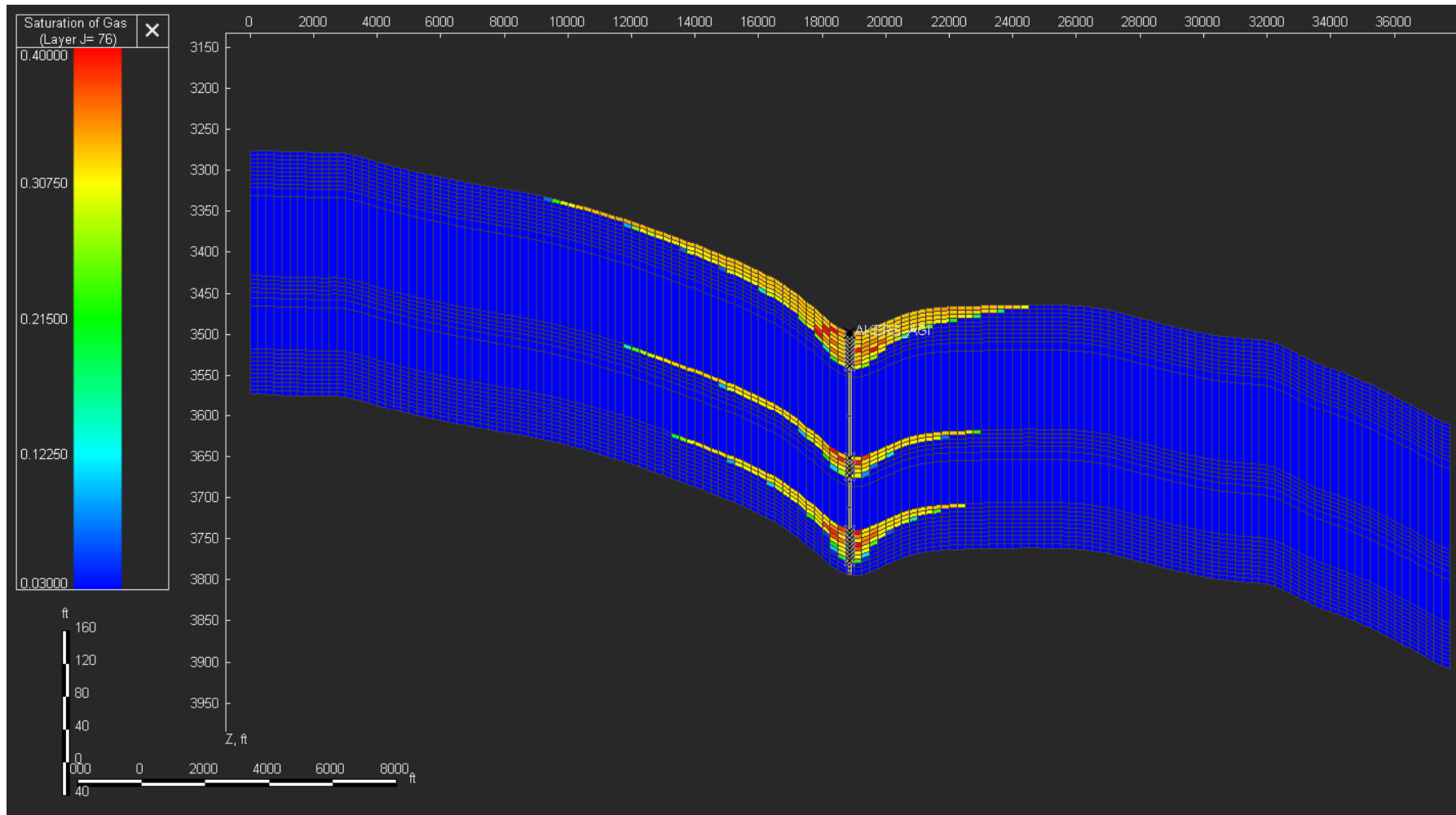

Figure 30 – West-East Cross-Sectional View of Woodbine Gas Saturation Plume at 25 Years After Shut-in (Stabilized).

Figure 31 shows the surface injection rate, BHP, and wellhead pressure (WHP) during the historical and future injection period. The modeled WHP was historically matched using permeability to resemble the historical WHP data. The BHP reaches a maximum of 1,866 psig at the end of injection. This buildup of 175 psig stays well below the 90% fracture pressure constraint of 2,324 psig. The maximum WHP associated with the maximum BHP reached is 1,075 psig, which is less than the maximum allowable 1,850 psig as set in the UIC permit application for this well. Table 11 shows the BHP during historical and future injection, as well as post-injection to show reservoir pressure stabilization.

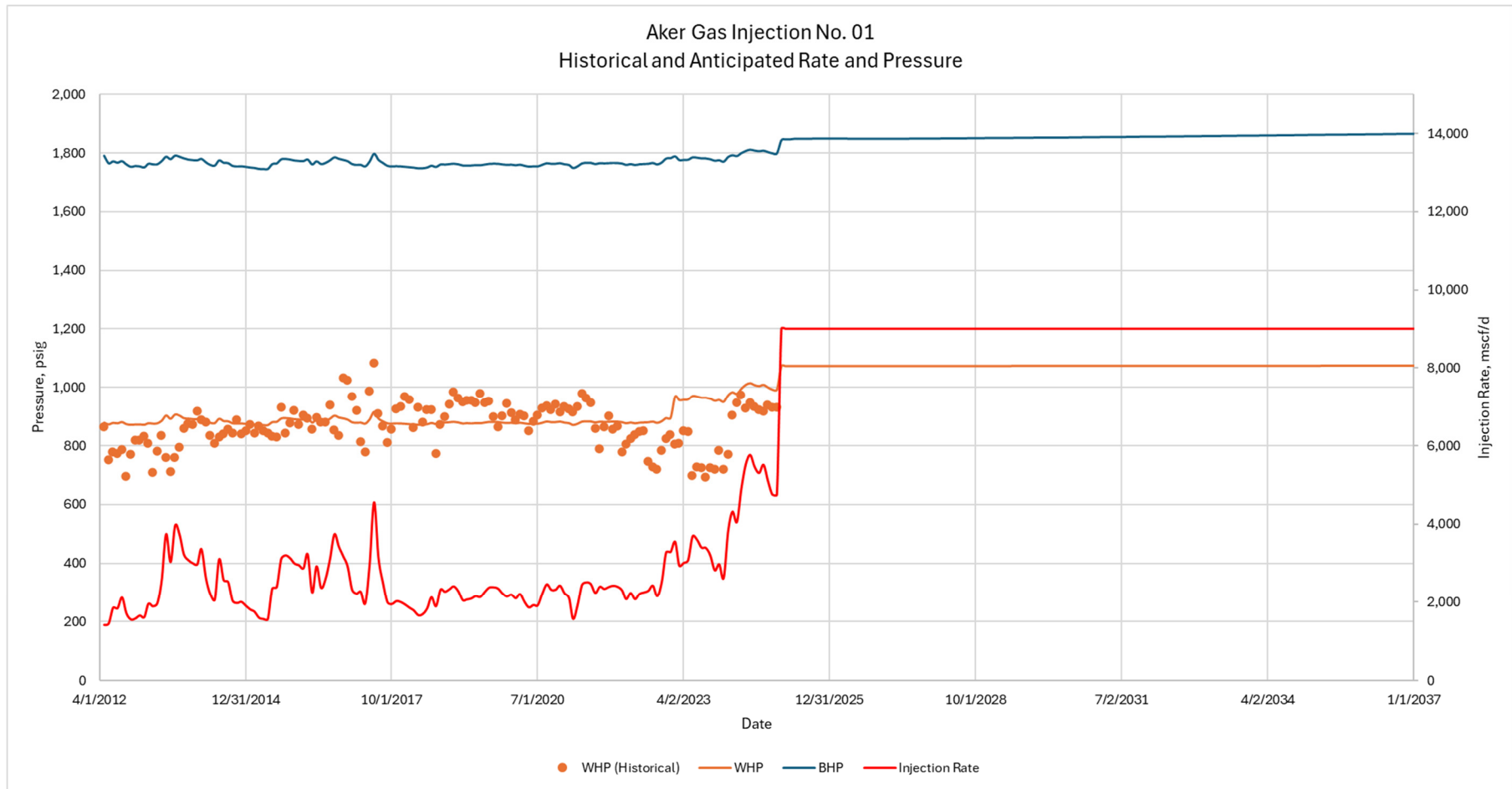

Figure 31 – Well Injection Rate and Bottomhole and Surface Pressures Over Time, Woodbine.

Table 11 – Historical and Future BHP

Time	Date	Bottomhole Pressure, psig
Start of Historical Injection	4/1/2012	1,690
	1/1/2015	1,753
	1/1/2020	1,761
Start of Maximum Permitted Injection	1/1/2025	1,800
	1/1/2028	1,851
	1/1/2031	1,855
	1/1/2034	1,860
End of Injection	1/1/2037	1,866
	1/1/2042	1,737
	1/1/2047	1,740
	1/1/2052	1,743
	1/1/2057	1,743
Plume Stabilization	1/1/2062	1,741

SECTION 3 – DELINEATION OF MONITORING AREA

The delineation of the Maximum Monitoring Area (MMA) and the Active Monitoring Area (AMA), as described in

3.1 Maximum Monitoring Area

The MMA is defined as equal to or greater than the area expected to contain the free-phase CO₂ plume until the plume has stabilized, plus a surrounding buffer zone of at least one half mile, as shown in Figure 32. Numerical simulation was used to predict the size and drift of the plume. Reservoir modeling was used to determine the areal extent and density drift of the plume, as described in *Section 2.15*. The model considers the following:

- Offset well logs to estimate geologic properties
- Petrophysical analysis to calculate the heterogeneity of the rock
- Geological interpretations to determine faulting and geologic structure
- Offset injection history to adequately predict the density drift of the plume

At the end of the injection period in Year 12, the areal extent of the plume covers 4,486 acres. The maximum distance between the wellbore and the edge of the plume is approximately 13,343 ft. After an additional 25 years of density drift and the plume has stabilized, and the areal extent of the plume covers 8,364 acres. The maximum distance to the edge of the plume at stabilization is approximately 15,982 ft. Figure 32 shows the plume area at the end of 25 years (stabilization) represented by the red line area, plus a one half mile buffer represented by the dashed red line (MMA).

3.2 Active Monitoring Area

The AMA boundary is established by superimposing the area based on (1) the anticipated plume location at the end of year (t), plus a buffer zone of one half mi, with (2) the area projected to contain the free-phase CO₂ plume at the end of year (t + 5). In this case, the value of (t) is set to equal the last year of the injection period, which is Year 12. The AMA is represented by the dashed green boundary in Figure 32 represents the AMA. However, for this MRV Plan, Midcoast G&P has set the AMA equal to the MMA.

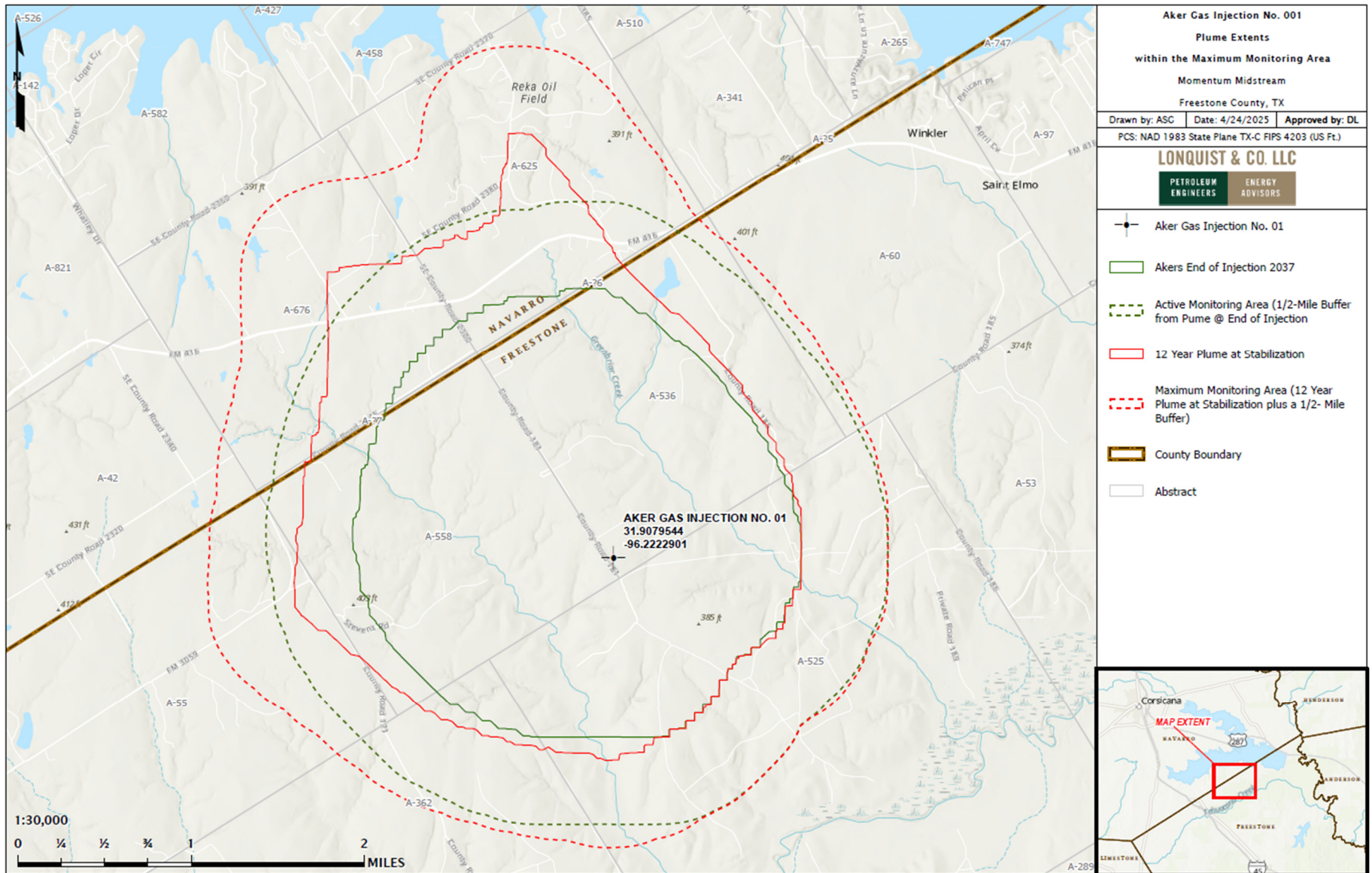

Figure 32 – Delineation of Maximum Monitoring Area.

SECTION 4 – POTENTIAL PATHWAYS FOR LEAKAGE

Potential CO₂ leakage pathways to the surface within the MMA are identified in this section and evaluated for likelihood, magnitude, and timing. A summary of these paths is provided in Table 12. The potential leakage pathways include the following:

- Leakage from surface equipment
- Leakage from existing wells within MMA
- Leakage from future drilling in MMA
- Leakage through faults and fractures
- Leakage through the UCZ
- Leakage from natural or induced seismicity

Table 12 – Potential Leakage Pathway Risk Assessment

Potential Leakage Pathway	Likelihood	Magnitude	Timing
Surface Equipment	Possible during injection operations.	Low. SCADA systems will detect leaks and execute safety shutdown procedures.	During active injection.
Existing wells within the MMA	Medium. Twenty-seven wells penetrate the Upper Confinement within the MMA. Only seven of these wells are within the stabilized plume.	Low. Multiple upper confining intervals and the TRRC SWR 13 completion requirements mitigate the risk of CO ₂ migration to the USDW and surface releases.	During active injection and until the plume stabilizes 25 years after injection ceases.
Future wells within the MMA	Medium. The area is active with oil and gas production. Any new wells in the MMA will drill through the plume, creating a risk.	Low. TRRC requires that any new wells penetrating the injection intervals be constructed in compliance with SWR 13 to prevent migration of CO ₂ . Additionally, there are multiple confining zones above the injection zone.	During active injection and until the plume stabilizes 25 years after injection ceases.
Faults and fractures	Low. No faults or fractures were identified in the Area of Review.	Low. Multiple UCZs should contain any leakage that would migrate through faulting.	During active injection and until the plume stabilizes 25 years after injection ceases.
Upper confining layers	Low. The UCZs have sufficient thickness, continuity, and confining characteristics.	Low. Leakage out of the injection interval is unlikely due to multiple UCZs.	During active injection and until the plume stabilizes 25 years after injection ceases.

Potential Leakage Pathway	Likelihood	Magnitude	Timing
Natural or induced seismicity	Low. A review seismic data shows no earthquakes of magnitude 2.0 or greater within 9.08 km radius, indicating a low probability of a seismic event.	Low. The UCZs should prevent migration out of the injection intervals in the event of induced seismicity.	During active injection and until the plume stabilizes 25 years after injection ceases.

Magnitude Assessment Description
Low - categorized as little to no impact to safety, health and the environment and the costs to mitigate are minimal.
Medium - potential risks to the USDW and for surface releases does exist, but circumstances can be easily remediated.
High - danger to the USDW and significant surface release may exist, and if occurs this would require significant costs to remediate.

These potential leakage pathways have the highest risk of leakage during the injection period. After the injection ceases in 2037, the risk of leakage from offset wells, fractures, etc., is reduced until the plume fully stabilizes in 2062 based on the plume model. The risks associated with leakage from the surface equipment are to be eliminated after the injection wells are plugged and the associated surface equipment is removed.

4.1 Leakage from Surface Equipment

The Aker Gas Plant and the Aker No. 1 well are existing facilities that have been in operation since 2010. These facilities are well-maintained and have a positive operating history for compliance and safety.

The sour gas stream is treated in the amine unit and separated into a sweet gas stream and an acid gas stream as depicted in Figure 33. The acid gas stream is then compressed, measured with the gas meter, and transported to the Aker No. 1 via pipeline for injection. The pipeline and wellhead are potential sources of leakage during injection operations, as the flanged connections and valves are the most likely failure points of the surface equipment. Additionally, damage may occur if any of the surface equipment is compromised due to an accident, corrosion, or a natural disaster, resulting in the release of the injectate.

Gas detectors for H₂S are installed at key locations within the facility, as shown in the site plan in Figures 43 and 44 and Appendix B. These devices are continuously monitored by the Supervisory Control and Data Acquisition (SCADA) system and will alarm at set points based on H₂S exposure limits as recommended by the Occupational Safety and Health Administration (OSHA).

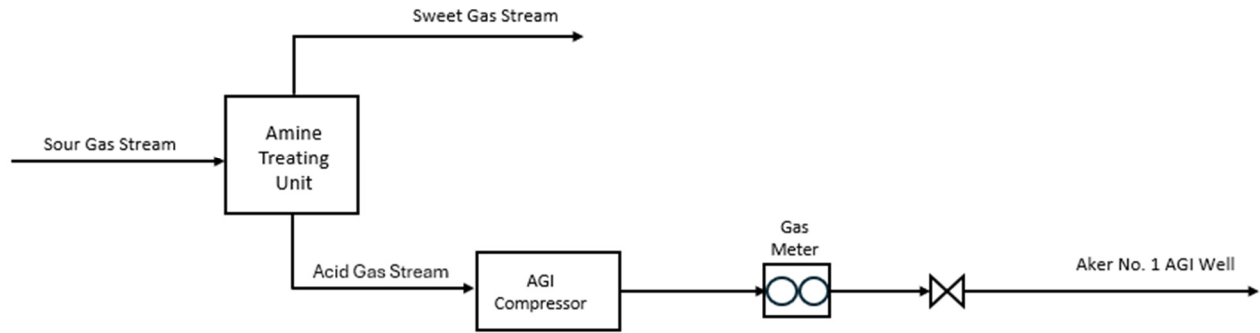

Figure 33 – Aker No. 1 Process Flow Diagram

4.2 Leakage from Wells in the MMA

4.2.1 Existing Wells Within the MMA

The Aker AGI wells are designed to prevent migration from the injection interval to the surface through a special casing and cementing design as depicted in the schematic provided in Figure 34. The annular spaces between the injection tubing and the long string casing are filled with an inert corrosion-inhibiting fluid as a further safety measure. A successful mechanical integrity test (MIT) is required under TRRC's 16 Texas Administrative Code (TAC) **§3.9** and **§3.46** before injection operations can begin. To maintain compliance, Class II AGI wells must undergo an MIT at least once every five years. Under Permit Amendment 13099, Midcoast G&P has agreed to perform an annual MIT on the Aker No. 1. A successful MIT demonstrates that there are no significant leaks in the casing, tubing, or packer and that the well is properly isolated from the USDWs. An unsuccessful MIT would indicate the potential of a leak; the well would be isolated, and the leak mitigated to prevent leakage of the injectate into another formation or to the atmosphere.

A map of the wells that penetrate the Upper Confinement within the MMA is shown in Figure 35. The MMA review map and a summary list of the wells that penetrate the Upper Confinement in the MMA are provided in Appendix C.

In this area, most of the drilling activity targets the Cotton Valley, Bossier, and Rodessa formations, which occur at depths of between 10,000 ft and 11,500 ft; significantly deeper than the Woodbine Formation. Well completions to this depth will typically have two casing strings cemented through the Woodbine, providing an additional layer of safety against possible corrosion.

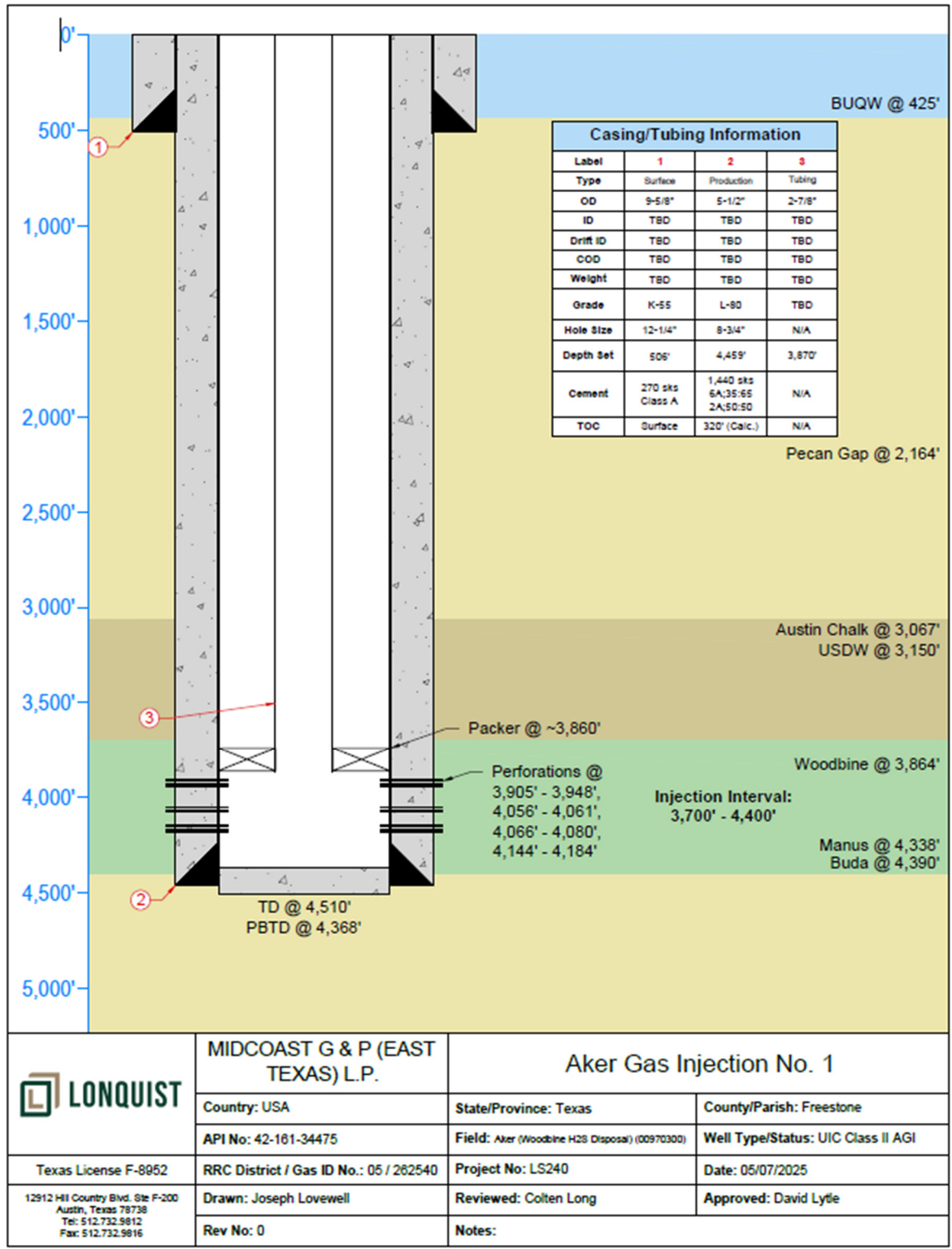

Figure 34 – Aker No. 1 Wellbore Schematic

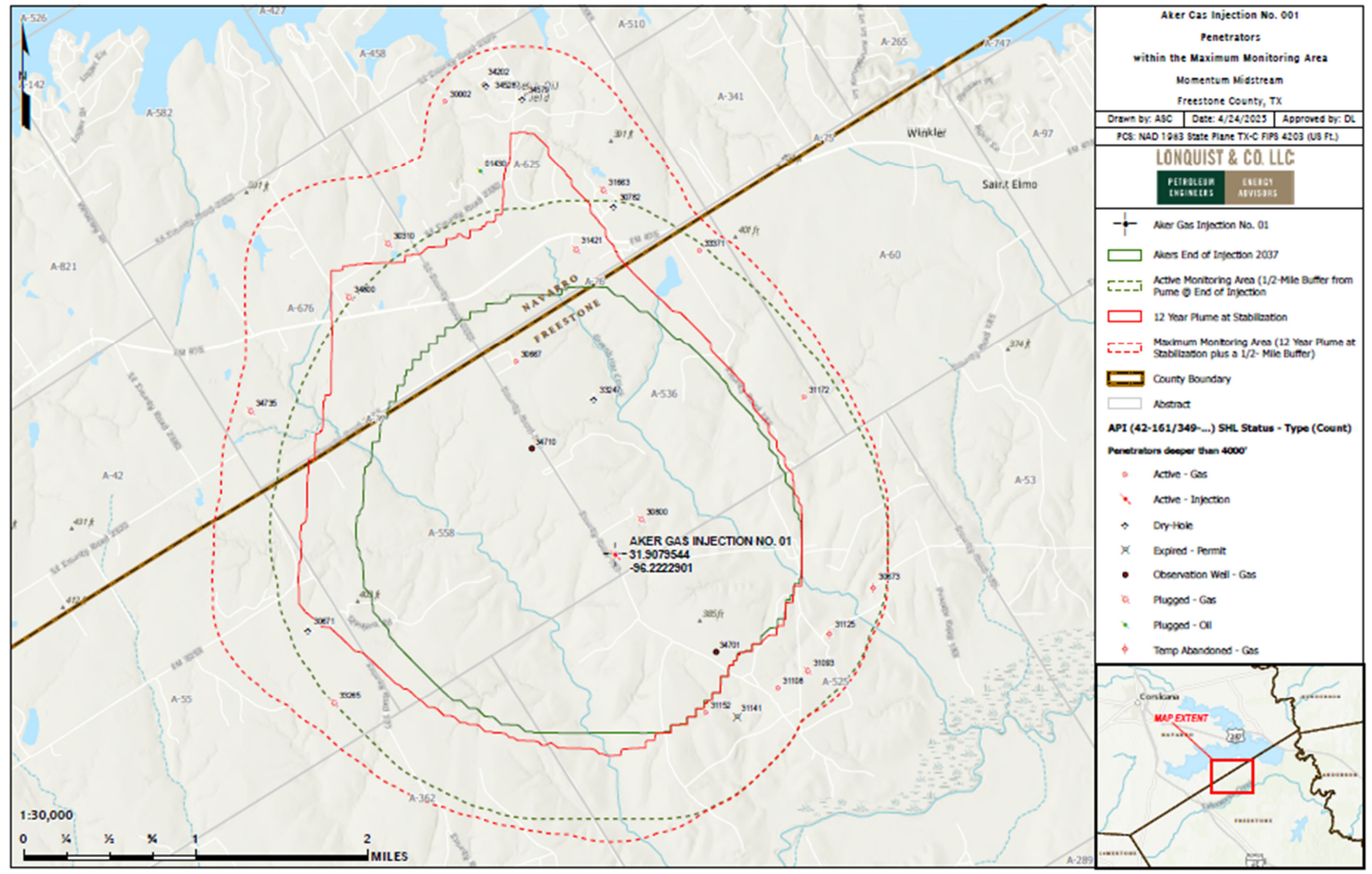

Figure 35 – Wells That Penetrate the Upper Confinement Within the Maximum Monitoring Area

4.2.2 Future Drilling

New wells drilled within the MMA will be required to comply with TAC Title 16, Part 1, Chapter 3, Section 3.13, which is titled (Casing, Cementing, Drilling, Well Control, and Completion Requirements). The rule establishes standards to prevent the waste of oil, gas, or geothermal resources and to protect usable quality water from contamination during drilling and production activities. For any wells drilled for oil or gas with surface and intermediate casing, the regulations require casing to be set at specific depths and cemented adequately to isolate productive zones, unusable water zones, and other subsurface formations. Midcoast G&P will monitor for any new permits and coordinate with the operator to ensure that if a proposed well may intersect the CO₂ plume that it will be constructed in a manner to prevent migration above the injection interval.

4.2.3 Freshwater Wells

A groundwater well search in the area identified 16 wells within the MMA, identified by the TWDB, shown in Figure 36, and a list of these wells is provided in Appendix C. The deepest of these wells has a total depth of 163 ft, which is significantly shallower than the UCZ of the Woodbine injection interval.

The surface casing is set at a depth of 506 ft and is cemented to surface, sufficiently below the Base of Usable Quality Water at 425 ft as shown in Figure 34, designed to isolate and protect the shallow freshwater aquifers, consistent with applicable TRRC regulations for this area. The wellbore casings and cement also prevent CO₂ leakage to the surface along the borehole. Midcoast G&P believes that leakage of CO₂ from the Woodbine Formation to the groundwater wells is unlikely.

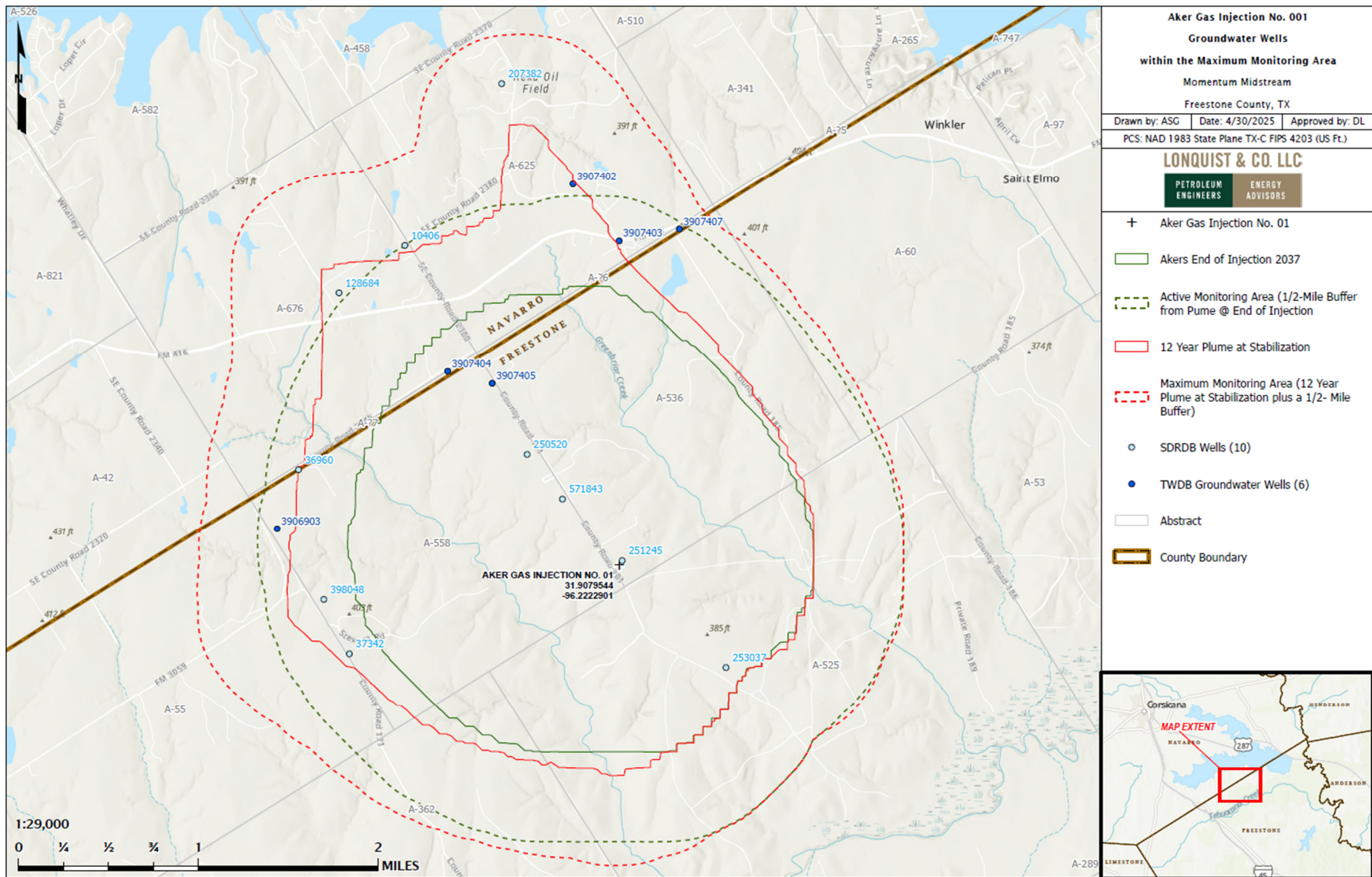

Figure 36 – Groundwater Wells within the MMA.

4.3 Leakage Through Faults or Fractures

No faults were identified within the confinement or injection zones in the AOR. With more than 10 years of operating history in the area, without incident, Midcoast G&P believes that leakage of CO₂ from the Woodbine Formation to the groundwater wells is unlikely.

4.4 Leakage Through Confining Layers

The Eagle Ford shale, a well-known competent barrier, provides upper confinement for the Woodbine interval, preventing CO₂ leakage. Its regional continuity, high clay content, and effective sealing properties, as detailed in Section 2.6, make it an ideal upper confining layer.

The Maness Shale underlies and confines the Woodbine. It is stratigraphically equivalent to the Eagle Ford Shale in areas where the Woodbine is absent. Similar to the Eagle Ford, the Maness Shale has robust sealing properties that effectively prevent fluid migration or leakage. Due to the competent barriers provided by both the upper and lower confining intervals, Midcoast G&P believes that leakage of CO₂ from the Woodbine formation is unlikely.

4.5 Leakage from Natural or Induced Seismicity

The USGS indicates that the Aker No. 1 site lies in a seismically quiet region of the U.S., as depicted in Figure 37. A review of the Bureau of Economic Geology's (BEG) TexNet catalog and the USGS Advanced National Seismic System websites showed no natural or induced seismic activity within 25 km (15.5 mi) of the Aker No. 1 injection site, as illustrated in Figures 38 and 39, respectively.

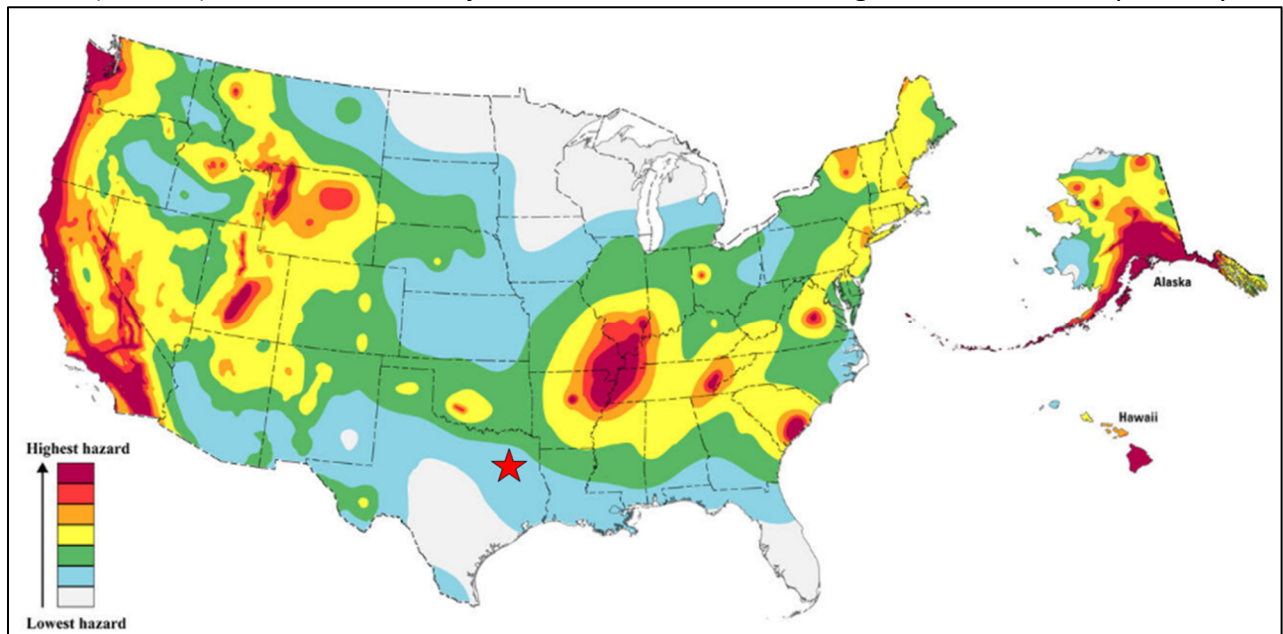

Figure 37 – Hazard map from the 2023 National Seismic Hazard Model Project with the approximate location of Akers No. 1 represented by the red star (modified from USGS, 2023).

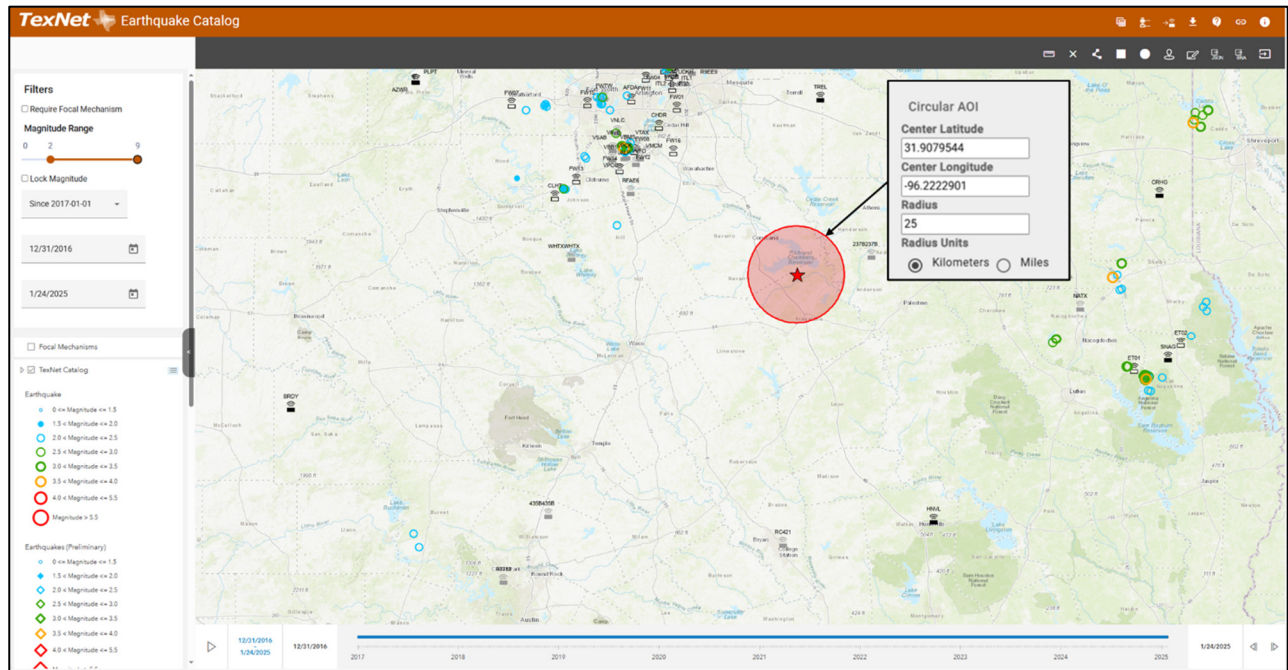

Figure 38 – BEG TexNet Earthquake Catalog query within a 25 km (15.5 mi) radius of the Akers No. 1 location shown by the red star. The query returned zero (0) earthquakes within the queried radius.

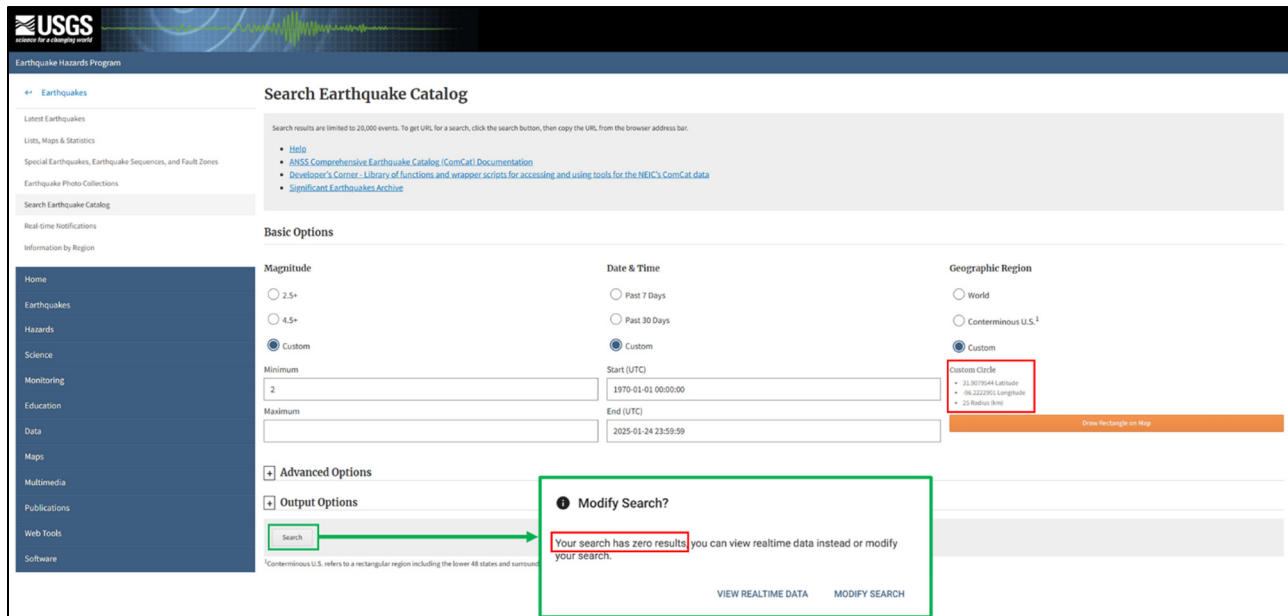

Figure 39 – USGS Earthquake Catalog query within a 25 km (15.5 mi) radius of the Akers No. 1 location which returned zero (0) earthquakes within the queried radius.

Although the well is outside the area of review, a search was conducted using a 100 km (62.1 mi) radius in the USGS database to return the closest recorded seismic events for reference purposes only. Figure 40 shows the queried results. The closest occurrence was 83 km (51.6 mi) west-

northwest from the Akers No. 1 injection site. Therefore, it is concluded that the Akers No. 1 injection operations have not yielded any observable seismic events in the past, nor would ongoing operations be expected to induce any seismicity events.

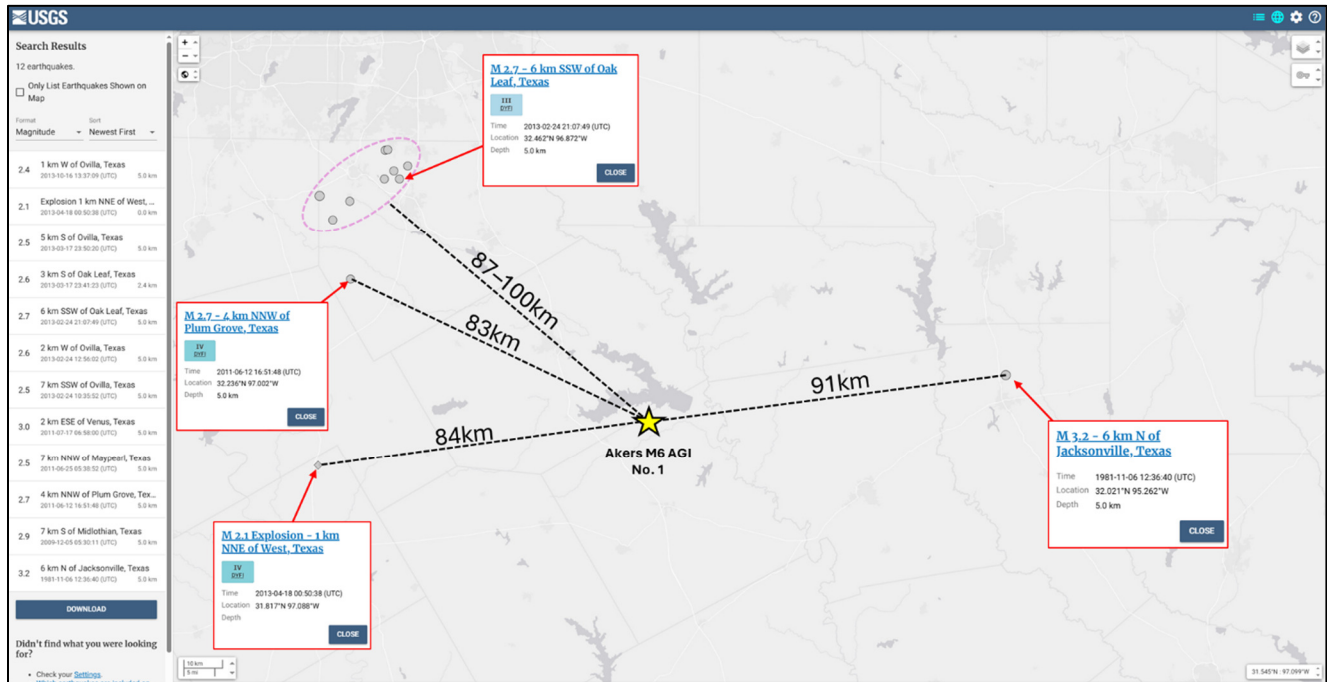

Figure 40 – USGS Earthquake Catalog query within a 100 km (62.1 mi) radius of the Akers No. 1 location to identify the closest recorded seismic event(s). These occurrences are all well outside of the AOR and are only shown for informative purposes.

SECTION 5 – MONITORING FOR LEAKAGE

This section discusses the monitoring strategy Midcoast G&P has designed in compliance with 40 CFR §98.448(a)(3). The strategy will be utilized to detect and quantify surface leakage of carbon dioxide through the pathways detailed in *Section 4*. The leakage pathways and monitoring methods are summarized in Table 13. Monitoring is planned until injection operations cease.

This section discusses the strategy that Midcoast G&P has designed to meet the requirements of 40 CFR §98.448(a)(3) for detecting and quantifying surface leakage of CO₂ through the pathways identified in Section 4. As the injectate stream contains both H₂S and CO₂, the H₂S will be a proxy for CO₂ leakage; therefore, the monitoring systems in place to detect H₂S will also indicate the release of CO₂. Monitoring will occur during the planned 12-year injection period or cessation of injection operations, plus a proposed 25-year post-injection period until the plume has stabilized.

- Leakage from surface equipment
- Leakage through existing and future wells within the MMA
- Leakage through faults, fractures
- Leakage through the upper confining layer
- Leakage through natural or induced seismicity

Table 13 – Summary of Leakage Monitoring Methods.

Leakage Pathway	Monitoring Method	Frequency
Surface Equipment	Fixed H ₂ S monitors throughout the Aker Gas Plant and Aker No. 1 well	Continuous
	Visual inspections	Daily
	SCADA continuous monitoring of the Aker Gas Plant and Aker No. 1 well	Continuous
Existing Wells	SCADA Continuous Monitoring at the Aker No. 1 well	Continuous
	Mechanical Integrity Test of the Aker No. 1 well	Annually
	Visual Inspections	As needed
	Annual soil gas sampling at well locations within the MMA	Annually
Drilling through MMA	Compliance with TRRC regulations	During operations
	Monitor Drilling Activity	During operations

Faults and Fractures	SCADA Monitoring at the Aker No. 1 well (volumes and pressures)	Continuous
Upper Confining Layer	SCADA Monitoring at the Aker No. 1 well (volumes and pressures)	Continuous
Natural or induced seismicity	Seismic monitoring station	Continuous

5.1 Leakage from Surface Equipment

The Aker Gas Plant and Aker No. 1 are designed and constructed to inject CO₂ and H₂S according to industry best practices and standards to minimize potential leakage points. Critical areas within the facility are constructed with materials that are National Association of Corrosion Engineers (NACE) and American Petroleum Institute (API) compliant. The Aker Gas Plant operations are monitored and controlled with Distributed Control Systems (DCS) and Supervisory Control and Data Acquisition (SCADA) systems providing 24/7 operational supervision. Baseline atmospheric H₂S/CO₂ concentrations are to be established prior to commencing injection volumes reported under this MRV plan. Ambient H₂S detectors are located throughout the Aker Gas Plant and near the Aker No. 1 well with local alarms. They are connected to the SCADA system for continuous monitoring.

Field personnel are to conduct routine inspections of detectors, gauges, and leak indicators, such as vapor plumes and ice formations. The internal and external corrosion control programs are to be monitored for effectiveness by way of periodic inspection of surface equipment, analysis of liquids collected directly from the piping, and cathodic protection system inspections.

Safety systems are to include emergency shutdown (ESD) valves that can isolate segments of the facility and the Aker No. 1 wellhead. A pressure relief valve is installed in the piping to prevent an overpressure event. The Aker Gas Plant is equipped with a flare stack to allow for piping and equipment to be vented or depressurized under safe and controlled operating conditions. In addition, the fixed in-field H₂S-specific devices have a high (Hi) alarm setpoint at 10 ppm and a Hi-Hi setpoint at 20 ppm. In the event of an alarm, personnel are trained to follow the H₂S Contingency Plan for safety and operational matters. Subsequent actions are to be taken to secure the facility and mitigate potential leaks. A safety plot plan for the Aker Gas Plant is provided, as shown in Figures 42 and 43, and is included in Appendix B.

Pressures, temperatures, and flow rates through the surface equipment are continuously monitored during operations. If a release occurred from surface equipment, the amount of CO₂ released is to be quantified based on the operating conditions, including pressure, flow rate, percentage of CO₂ in the acid gas stream, the size of the leak-point opening, and duration of the leak. In the unlikely event a leak occurs, Midcoast G&P will quantify the leak in accordance with the strategies discussed in *Section 7* and in accordance with 40 CFR **§98.448(a)(5)** and **§98.444(d)**.

5.2 Leakage from Wells Within MMA

Midcoast G&P will continuously monitor and collect injection volumes, pressures, and temperatures through their SCADA systems for the Aker No. 1 well. This data will be reviewed by qualified personnel and will follow response and reporting procedures when the data is outside of the normal operating range. A change of injection or annular pressure would indicate the presence of a possible leak and would be thoroughly investigated. In addition, an MIT (H-5) will be performed annually as required by Permit Amendment 13099. An unsuccessful MIT would indicate the potential of a leak. Upon an unsuccessful MIT, the well would be isolated, the circumstance would be investigated, and the leak would be mitigated.

In addition to the fixed monitors described previously, Midcoast G&P will establish and operate an in-field monitoring program to detect CO₂ leakage within the MMA. This program would include H₂S monitoring as a proxy for CO₂ at the Aker No. 1 wellsite and annual soil gas samples taken near identified wells within the MMA. The samples will be analyzed by a qualified third party and used to establish a monitoring baseline. Baseline samples will be taken by the end of July 2025, and annually thereafter through the injection period and through the post-injection site care period.

5.2.1 Leakage from Wells that Penetrate the Upper Confinement

There are 27 wells that penetrate the upper confining zone (UCZ) found within the MMA. Five of these wells are located within the Injection Plume noted by the green line in Figure 41, and there are four wells located within the modeled Stabilized Plume noted by the red line. Five of these wells are either dry holes or wells that have been plugged and abandoned. Midcoast G&P operates two observation wells within the injection plume that are completed in the Woodbine Formation. These wells are noted on the map by the red circles. Midcoast G&P will monitor these two observation wells for wellhead pressure and any irregularities. Additionally, Midcoast G&P will perform baseline and annual soil gas monitoring around select penetrators of the UCZ within the MMA.

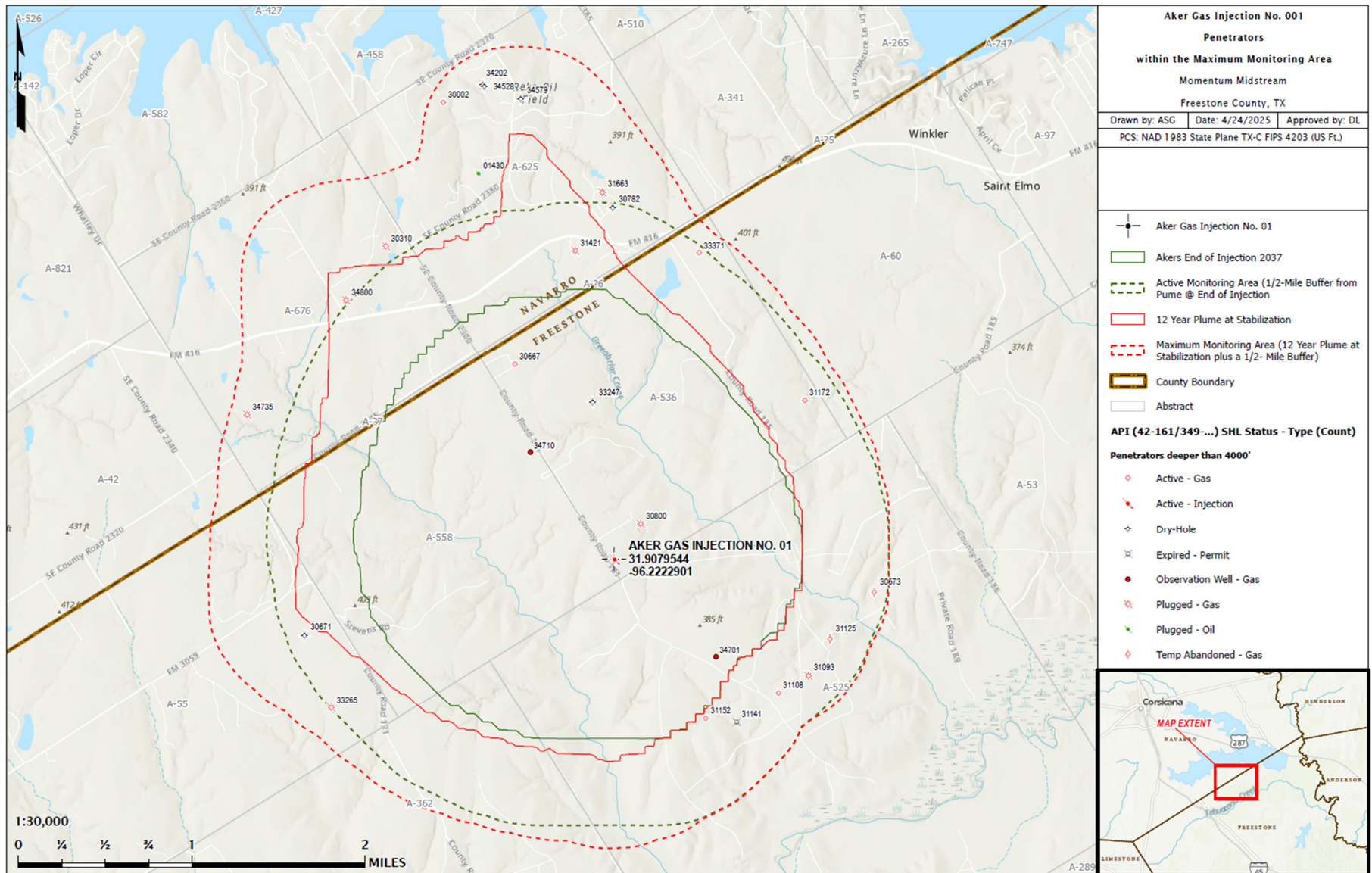

Figure 41 – Wells that Penetrate the Upper Confinement Within the MMA.

5.2.2 Leakage from Future Wells within MMA

5.2.2.1 Aker No. 1 Injection Well

The Aker No. 1 was designed and constructed to prevent the migration of CO₂ from the injection interval to the surface. The casing strings for the proposed Aker No. 1 well were designed in accordance with the GAU letter issued for this site and applicable TRRC regulations to safeguard shallow freshwater aquifers and USDWs. The well construction contains premium materials. The well design is illustrated in Figure 42. The likelihood of leakage from the Aker No. 1 injection well is remote.

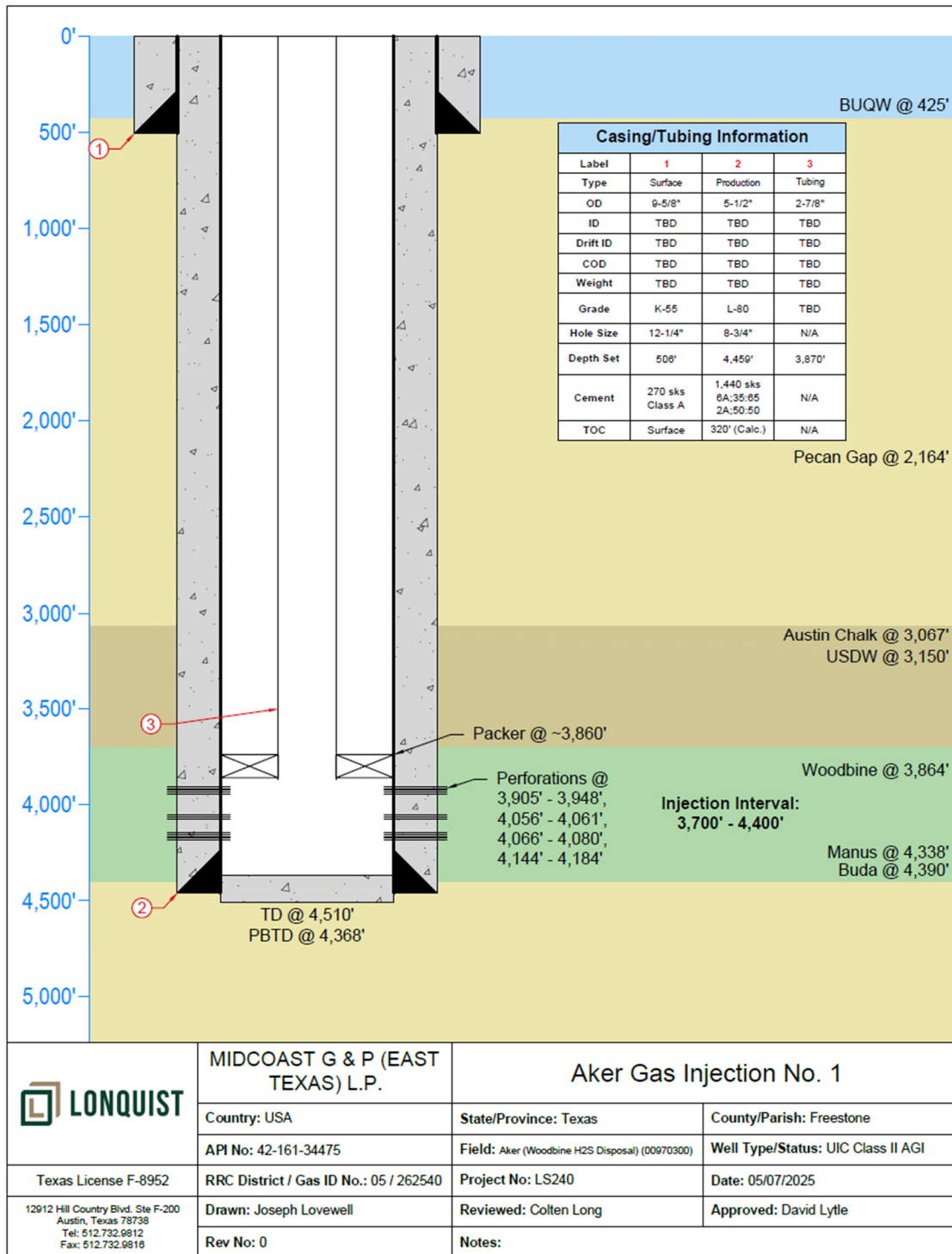

Figure 42 – Aker No. 1 Wellbore Schematic.

Statewide Rule (SWR) §3.46 [40 CFR §146.23 (b)(3)] requires mechanical integrity tests (MITs) to be run every 5 years to confirm that the well and wellhead can safely hold the appropriate amount of pressure. Under Permit Amendment 13099, Midcoast G&P has agreed to perform an annual MIT

on the Aker No. 1. Should the Aker No. 1 fail an MIT, the well would be removed from service and isolated. A root cause analysis would be performed to determine the source of the leak and promptly be repaired to mitigate leakage. Monitoring equipment will be installed in the well, including traditional surface-pressure monitoring on the tubing, casing, and surface casing.

Midcoast G&P will ensure the continuous monitoring and collection of data, including injection volume, temperature, pressure, and gas composition data for the Aker No. 1. The data will be recorded via SCADA systems and reviewed by qualified personnel who will respond according to designated response and reporting procedures if set performance limits are exceeded. A temperature and pressure gauge will be placed at the wellhead in the injection stream, and a pressure gauge will be placed on the casing annulus. Changes in annular pressure would signal the presence of a possible leak.

The Aker No. 1 wellsite will be equipped with a volumetric flow meter, ESD valve, and gas monitors as illustrated in Figures 43 and 44.

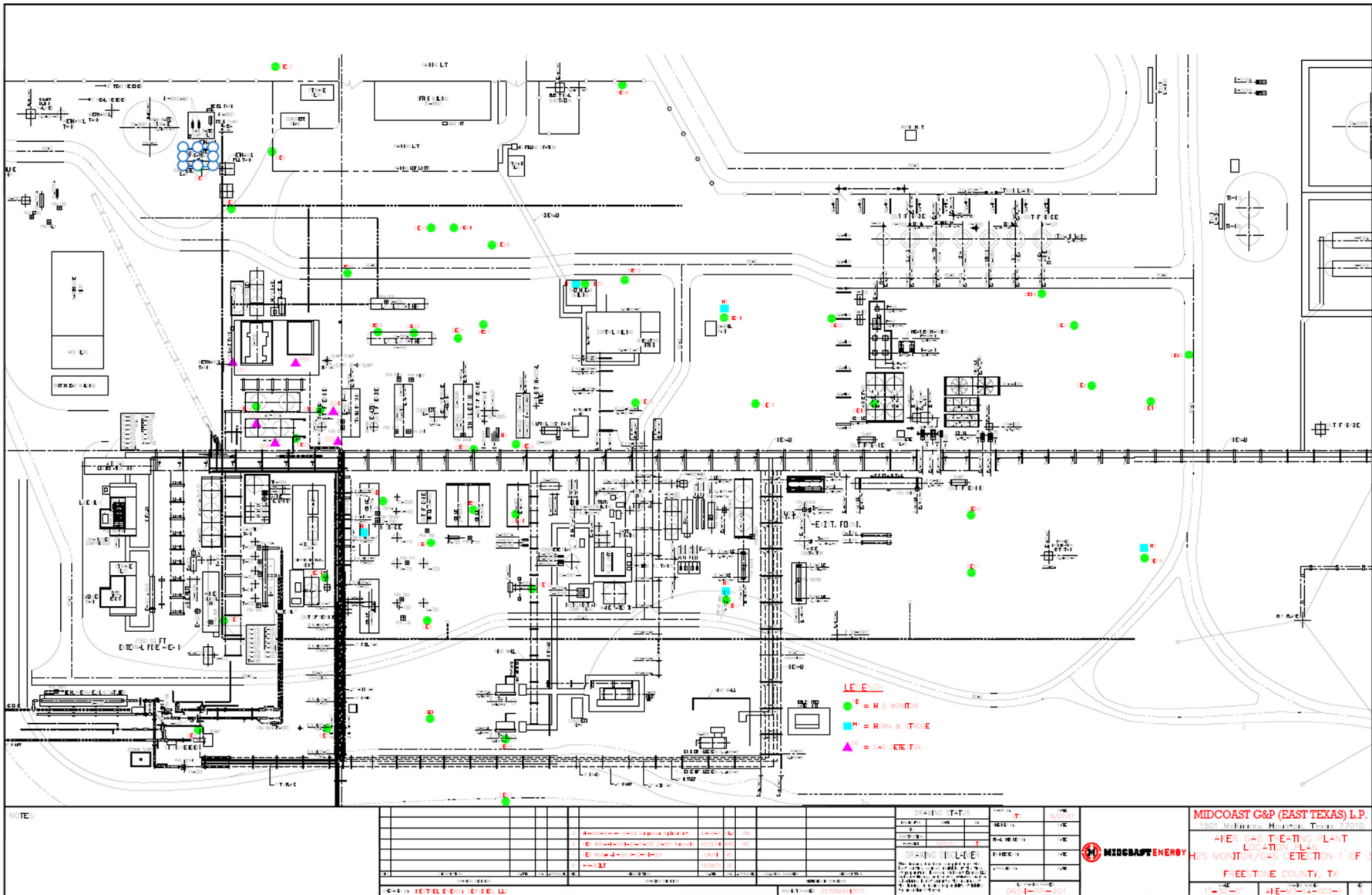

Figure 43 – Aker No. 1 Monitoring and Safety Equipment.

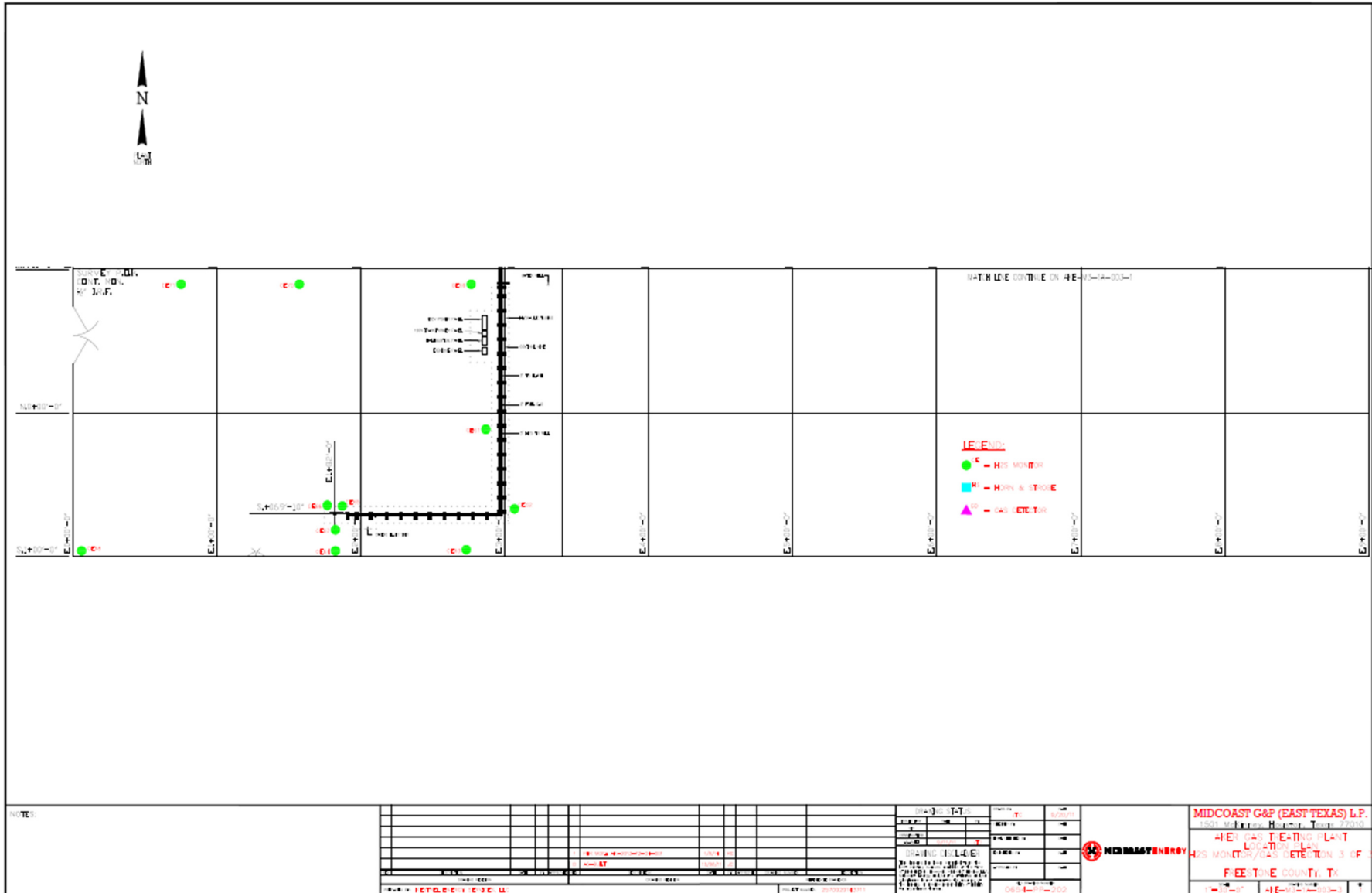

Figure 44 – Aker No. 1 Monitoring and Safety Equipment (Part 2).

5.2.2.2 Non-Midcoast G&P Operated Wells

Midcoast G&P will routinely monitor the TRRC site for permits and drilling activities in the AOR, and for operators' compliance with TRRC SWR Rule 13 (Casing, Cementing, Drilling, Well Control, and Completion Requirements), 16 TAC §3.13. Operators in Freestone and Navarro Counties and Districts 5 and 6, where the Aker No. 1 is located, must comply with TRCC SWR Rule 13, which requires that oil and gas operators set steel casing and cement the well as follows:

- Above and across all formations permitted for injection under TRRC Rule 9
- Immediately above all formations permitted for injection under TRRC Rule 46 for any proposed well within a $\frac{3}{4}$ mi radius of an injection well

SWR Rule 13 also requires operators to case and cement both above and across all potential flow zones and zones containing corrosive formation fluids, which makes the likelihood of leakage from possible new wells remote.

5.2.3 Leakage Through Groundwater Wells Within MMA

Midcoast G&P will perform baseline and annual groundwater sampling from well No. 3907403 in the northern portion of the stabilized plume, as seen in Figure 36. These water samples will be analyzed by a third-party laboratory for key constituents specific to the acid gas stream, such as CO₂, H₂S, pH, temperature, and other standard laboratory measurements. Any significant variances found in future samples will be evaluated to identify the possible leakage of CO₂.

5.3 Leakage Through Faults, Fractures, or Confining Layer

Midcoast G&P is operating and will continue to operate Aker No. 1 at injection pressures below the permit limits approved by the TRRC, thereby minimizing the potential for induced seismicity. Midcoast G&P will use its SCADA systems to monitor these operating set points. If these limits are exceeded, alerts are to be triggered to note the operating events. Field personnel will review the data associated with the alert and determine if there has been a risk to the confining seal of the sequestering formation and will take prudent actions as necessary based on the findings.

The data reviewed in *Section 4 – Potential Pathways for Leakage* suggests there is a very low likelihood of potential for leakage through faults, fractures, or the confining layers at the Aker No. 1 location. The upper confining (Eagle Ford Shale) and lower confining (Maness Shale) zones exhibit low permeability and are of sufficient thickness and lateral continuity to serve as complete fluid flow barriers. No faulting was identified in the area by way of subsurface interpretation or white paper research, thus making leakage through faults unlikely.

5.4 Leakage Through Natural or Induced Seismicity

The BEG has established a seismic monitoring network (TexNet) to monitor seismic activity within the State of Texas. Currently, one TexNet monitoring station (No. 237B) exists approximately 40 km

east-northeast of the Aker No. 1, as shown in Figure 45. Midcoast G&P will monitor the TexNet and USGS earthquake catalogs. If a seismic event of 2.0 magnitude or greater is detected, Midcoast G&P will investigate the injection volumes and pressures by way of continuous monitoring systems at the Aker No. 1, to determine if any significant changes occurred that would indicate potential leakage. The data reviewed in *Section 4.5* suggests seismicity will not pose a risk of CO₂ migration to the surface in the surrounding MMA around this location, as the nearest seismic activity was recorded 83 km away. The Aker No. 1 is in a relatively inactive portion of the United States from a regional seismic perspective.

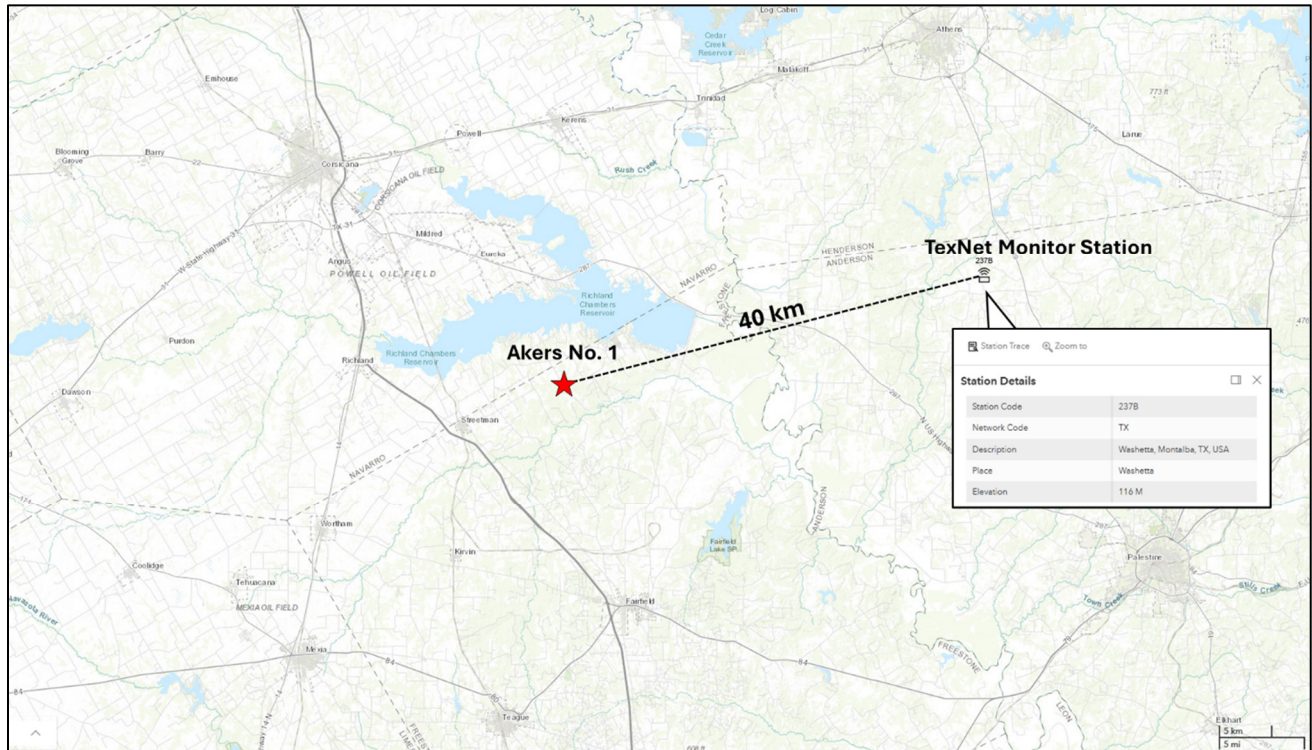

Figure 45 – Map showing nearest TexNet monitoring station No. 237B, located 40 km east-northeast of Aker No. 1.

SECTION 6 – BASELINE DETERMINATIONS

This section identifies the strategies Midcoast G&P will undertake to establish the expected baselines for monitoring CO₂ surface leakage in accordance with 40 CFR §98.448(a)(4). Midcoast G&P will use its SCADA system to identify changes from the expected baseline performance that may indicate leakage and quantify the corresponding amounts of CO₂.

6.1 Visual Inspections

Regular inspections are to be conducted by field personnel at the Aker Gas Plant, the Aker No. 1, and the Aker monitoring wells. These inspections are to aid in identifying and addressing possible issues to minimize the risk of leakage. If any issues are identified, corrective actions are to be taken in accordance with the H₂S Contingency Plan's safety practices.

6.2 CO₂/H₂S Detection

Because of the presence of H₂S in the acid gas stream with the CO₂, Midcoast G&P has an H₂S Contingency Plan in place as is required by the TRRC to monitor for releases. The H₂S detection is used as a proxy for identifying the release of CO₂. Midcoast G&P has installed H₂S monitors throughout the facility, as discussed in Section 5.1.

In addition to the H₂S monitors, Midcoast G&P will establish and operate a soil gas monitoring program to detect leakage of CO₂ within the MMA. Soil gas samples will be collected from select artificial penetration locations within the MMA and analyzed by a third-party laboratory to establish baseline values. The soil gas sampling will be performed annually thereafter.

6.3 Operational Data

Midcoast G&P will record various pressure measurements relating to the Aker No. 1 well before starting injection under this MRV plan. These could include wellhead, annular, and bottom hole pressures, for example. These recorded pressures will establish baseline measurements for reference to future operating pressures. Any significant deviations over time will be analyzed for indication of leakage of acid gas and the corresponding component quantities of CO₂.

6.4 Continuous Monitoring

The total mass of CO₂ emitted by surface leakage and equipment leaks will not be measured directly, as the injection stream for this project is well beyond the Occupational Safety and Health Administration (OSHA) Permissible Exposure Limit (PEL) 8-hour Time Weighted Average (TWA) of 5,000 ppm. Direct leak surveys are dangerous and present a hazard to personnel because of the presence of H₂S in the gas stream. Continuous monitoring systems are designed to trigger an alarm if there is a release. The mass of the CO₂ released would be calculated based on the operating conditions, including pressure, flow rate, percentage of CO₂, size of the leak-point opening, and duration. This method is consistent with 40 CFR §98.448(a)(5) and §98.444(d), allowing the operator to calculate site-specific variables used in the mass balance equation.

In the case of an operational event, the acid gas stream will be diverted to a flare stack to be safely processed and vented. The event will be documented and reported as required by the TRRC and EPA.

6.5 Groundwater Monitoring

Midcoast G&P will perform baseline and annual groundwater sampling from well No. 3907403 in the northern portion of the stabilized plume. This location is updip of the Aker No. 1 and is in an advantageous position to provide an early indication, should any CO₂ migrate from the Woodbine formation into shallow surface water zones. A third-party laboratory will be used to analyze the samples and establish the baseline properties of the groundwater. The parameters to be measured will include pH, total dissolved solids, total inorganic and organic carbons, density, temperature, and other standard laboratory measurements. Any significant variances found in future annual samples will be evaluated for possible leakage of CO₂.

SECTION 7 – SITE-SPECIFIC CONSIDERATIONS FOR MASS BALANCE EQUATION

This section presents the calculation methods Midcoast G&P will employ to determine the mass of CO₂ injected, emitted, and sequestered. Site-specific variables for calculating CO₂ emissions from equipment leaks and vented emissions of CO₂ between the injection well and injection volumetric flow meter, in accordance with 40 CFR §98.448(a)(5), are also stated.

7.1 Mass of CO₂ Received

40 CFR §98.443 requires the mass of CO₂ received to be calculated using the specified CO₂ received equations “unless you follow the procedures in 40 CFR §98.444(a)(4).” According to 40 CFR §98.444(a)(4), “if the CO₂ you receive is wholly injected and is not mixed with any other supply of CO₂, you may report the annual mass of CO₂ injected that you determined following the requirements under paragraph (b) of this section as the total annual mass of CO₂ received instead of using Equation RR-1 or RR-2 of this subpart to calculate CO₂ received.” The CO₂ received for the Aker No. 1 well is to be wholly injected and not combined with any other supply source; the annual mass of CO₂ injected is to be equal to the amount received. Any additional future streams are to be separately metered before being combined into the calculated injection stream.

7.2 Mass of CO₂ Injected

In accordance with 40 CFR §98.444(b), because a volumetric flow meter is to be used to measure the flow rate of CO₂ injected, the total annual mass of CO₂ in metric tons is to be calculated by multiplying the volumetric flow at standard conditions by the CO₂ concentration in the flow and the density of CO₂ at standard conditions according to Equation RR-5:

$$CO_{2,u} = \sum_{p=1}^4 Q_{p,u} * D * C_{CO_2,p,u}$$

Where:

CO_{2,u} = Annual CO₂ mass injected (metric tons) as measured by flow meter u.

Q_{p,u} = Quarterly volumetric flow rate measurement for flow meter u in quarter p at standard conditions (standard cubic meters per quarter).

D = Density of CO₂ at standard conditions (metric tons per standard cubic meter):
0.0018682

C_{CO₂,p,u} = CO₂ concentration measurement in flow for flow meter u in quarter p (vol. percent CO₂, expressed as a decimal fraction).

p = Quarter of the year

u = Flow meter

7.3 Mass of CO₂ Produced

The Aker Gas Plant is not part of an enhanced oil recovery project; therefore, no CO₂ will be produced from the Aker No. 1 well.

7.4 Mass of CO₂ Emitted by Surface Leakage and Equipment Leaks

The mass of CO₂ emitted by surface leakage will not be measured directly due to the presence of H₂S in the injection stream and the safety risk that direct leak surveys present for personnel. Because no venting is expected to occur, the calculations would be based on an unusual blowdown event, with those gas volumes being sent to a flare stack and reported as part of the Aker Gas Plant's reporting requirements. Any leakage would be detected and managed as an upset event. SCADA continuous monitoring systems would trigger an alarm upon a release of H₂S and CO₂. The mass of the CO₂ released would be calculated based on the operating conditions, including pressure, flow rate, size of the leak-point opening, and duration of the leak. This method is consistent with 40 CFR **§98.448(a)(5)** and allows the operator to calculate site-specific variables used in the mass balance equation.

In the unlikely event CO₂ is released due to a surface leak, the mass emitted would be calculated for each surface pathway according to methods outlined in the plan and totaled using Equation RR-10 as follows:

$$CO_{2E} = \sum_{x=1}^X CO_{2,x}$$

Where:

CO_{2E} = Total annual CO₂ mass emitted by surface leakage (metric tons) in the reporting year

CO_{2,x} = Annual CO₂ mass emitted (metric tons) at leakage pathway x in the reporting year

X = Leakage pathway

Calculation methods from Subpart W will be used to calculate CO₂ emissions from equipment located on the surface between the volumetric flow meter and the Aker No. 1 wellhead.

Midcoast G&P believes the potential pathways for all previously mentioned forms of leakage are unlikely. Given the possibility of uncertainty around the cause of a leakage pathway, Midcoast G&P believes the most appropriate method to quantify the mass of CO₂ released will be determined on a case-by-case assessment of the circumstances. Any mass of CO₂ detected leaking to the surface will be quantified by using industry-proven engineering methods, including but not limited to engineering analysis on surface and subsurface measurement data, dynamic reservoir modeling, and history-matching of the sequestering reservoir performance. In the unlikely event a leak occurs, it will be addressed, quantified, and documented within the appropriate timeline. Any records of leakage events will be kept and stored as stated in *Section 10*.

7.5 Mass of CO₂ Sequestered

Midcoast G&P plans to begin injections in the third quarter of 2025, at which time data collection will begin for calculating sequestered amounts. The mass of CO₂ sequestered will be calculated based on Equation RR-12. When injection operations commence, Midcoast G&P will begin collecting data for reporting under this plan based on the approval of this MRV plan and any applicable stipulations therein. The calculation of sequestered volumes will utilize the following equation because these wells will not actively produce oil, natural gas, or any other fluids:

$$CO_2 = CO_{2I} - CO_{2E} - CO_{2FI}$$

Where:

CO₂ = Total annual CO₂ mass sequestered in subsurface geologic formations (metric tons) at the facility in the reporting year

CO_{2I} = Total annual CO₂ mass injected (metric tons) in the well or group of wells covered by this source category in the reporting year

CO_{2E} = Total annual CO₂ mass emitted (metric tons) by surface leakage in the reporting year

CO_{2FI} = Total annual CO₂ mass emitted (metric tons) from equipment leaks and vented emissions of CO₂ from equipment located on the surface between the flow meter used to measure injection quantity and the injection wellhead, for which a calculation procedure is provided in subpart W of this part.

Because no venting will occur, the calculations would be made in case of an unusual event in which a blowdown is required. Those emissions sent to flares would be reported as part of the required GHGRP for the gas plant.

Equations from Subpart W – Petroleum and Natural Gas Systems **§98.232** will be used to calculate CO₂ emissions from equipment located on the surface between the flow meter used to measure injection quantities and the injection wellhead.

7.6 Mass of CO₂ Emitted Due to Leaks Other Than Surface Equipment

Given the uncertainty of sources other than surface equipment that may create leakage pathways, Midcoast G&P will quantify the mass of CO₂ released based on specific parameters at the time of release. Any mass of CO₂ detected leaking to the surface will be quantified by using industry-proven methods such as engineering analysis of surface and subsurface measurement data, dynamic reservoir modeling, and history-matching of the sequestering reservoir performance. In the rare event a leak occurs, it will be addressed, quantified, and documented within an appropriate timeline. Records of leakage events will be kept and retained as stated in *Section 10*.

SECTION 8 – IMPLEMENTATION SCHEDULE FOR MRV PLAN

The Aker No. 1 well is also subject to reporting injected volumes and pressures under the TRRC Class II regulations. Midcoast G&P is submitting this MRV application to the GHGRP to comply with the requirements of Subpart RR. The MRV plan is to be implemented upon receiving EPA approval. The Annual Subpart RR Report is to be filed on March 31 of the year following the reporting year.

Midcoast G&P will perform the baseline surveys, as discussed in Section 6, by the end of July 2025.

SECTION 9 – QUALITY ASSURANCE

Midcoast G&P plans to manage quality assurance and quality control (QA/QC) under the requirements of 40 CFR **§98.444**, using the methods identified in this section.

9.1 Monitoring Quality Assurance and Quality Control

CO₂ Injected

- The flow rate of the acid gas being injected is to be measured with a volumetric flow meter, consistent with applicable industry standards in accordance with 40 CFR **§98.448**. These flow rates will be compiled quarterly.
- The composition of the acid gas stream will be measured downstream of the amine unit with either a continuous gas chromatograph or sampled regularly and analyzed by a qualified lab consistent with industry best practices. The analysis of the acid gas will be used with the volumetric flow meter data to calculate the volume of CO₂ in the acid gas stream.
- The composition of the measured acid gas stream will be averaged quarterly.
- The acid gas measurement equipment will be calibrated in accordance with the requirements of 40 CFR **§98.444(e)** and **98.3(i)** of the GHGRP in conjunction with manufacturer recommendations.

CO₂ Emissions from Leaks and Vented Emissions

- Gas monitors will be operated continuously, except for maintenance and calibration.
- Gas monitors will be calibrated according to manufacturer recommendations and the requirements of 40 CFR **§98.444(e)** and **98.3(i)**.
- Calculation methods using equations from Subpart W will be used to calculate CO₂ emissions due to any surface leakage between the volumetric flow meter used to measure injection quantities and the Aker No. 1 well.

Measurement Devices

- The flow meter will be continuously operated except for maintenance and calibration.
- The flow meter will be calibrated according to the requirements in 40 CFR **§98.3(i)**.
- The flow meter will be operated and maintained in accordance with applicable industry standards, as published by a consensus-based standards organization.

All quantities of CO₂ will be converted to standard cubic meters at an absolute pressure of 1 atmosphere and a temperature of 60°F.

9.2 Missing Data

In accordance with 40 CFR **§98.445**, Midcoast G&P will use the following procedures to estimate missing data if the data needed for the mass balance calculations was not collected:

- If a quarterly quantity of CO₂ injected is missing, the amount will be estimated using a representative quantity of CO₂ injected from the nearest previous period at a similar injection pressure.
- Fugitive CO₂ emissions from surface equipment leaks will be estimated and reported per the procedures specified in Subpart W of 40 CFR **§98**.

9.3 MRV Plan Revisions

If any changes outlined in 40 CFR **§98.448(d)** occur, Midcoast G&P will revise and submit an amended MRV plan to the Administrator for approval within 180 days. At least 180 days before the end of the initial 5 years of active injection, an amended MRV plan will be submitted for this facility with an updated plume extent based on measured conditions in the wells. At that time, the extent of the AMA and MMA will be revised.

SECTION 10 – RECORDS RETENTION

In adherence to the requirements of 40 CFR §98.3(g), Midcoast G&P will retain records for at least 3 years and include the following:

- Quarterly records of the CO₂ injected
 - Volumetric flow rates at standard conditions
 - Volumetric flow rates at operating conditions
 - Operating temperature and pressure
 - Concentration of the acid gas stream (CO₂, H₂S, and other) stream
- Annual records of the information used to calculate the CO₂ emitted by surface leakage from leakage pathways.
- Annual records of information used to calculate CO₂ emitted from equipment leaks and from equipment located on the surface between the gas meter used to measure injection quantity at the Aker Gas Plant, and the injection volumetric flow meter at the Aker Well No. 1 wellhead.

REFERENCES

- Ambrose, W. A., Hentz, T. F., Bonnaffe, F. and others (2009). Sequence-stratigraphic controls on complex reservoir architecture of highstand fluvial-dominated deltaic and lowstand valley-fill deposits in the Upper Cretaceous (Cenomanian) Woodbine Group, East Texas field: Regional and local perspectives. *AAPG Bulletin*, Vol. 93, No. 2, p. 231-269.
- Bruun, B., Jackson, K., and Lake, P. (2016). Texas Aquifers Study: Groundwater Quantity, Quality, Flow, and Contributions to Surface Water. *KIP Articles*, No. 4891.
- Calavan, C. W. (1985). Depositional environments and basinal setting of the Cretaceous Woodbine Sandstone, Northeast Texas. *AAPG Bulletin*, Vol. 69, No. 1, 125 pp.
- Dawson, W. C. (1997). Limestone microfacies and sequence stratigraphy: Eagle Ford Group (Cenomanian-Turonian) north-central Texas outcrops. *Gulf Coast Association of Geological Societies Transactions*, Vol. 47, p. 99-105.
- Dawson, W. C., and Almon, W. R. (2010). Eagle Ford Shale Variability: Sedimentologic Influences on Source and Reservoir Character in an Unconventional Resource Unit. *Gulf Coast Association of Geological Societies Transactions*, Vol. 60, p. 181-190.
- Dennen, K.O., and Hackley, P.C. (2012). USGS Publications Warehouse: Definition of Greater Gulf Basin Lower Cretaceous and Upper Cretaceous Lower Cenomanian Shale Gas Assessment Unit, United States Gulf of Mexico basin onshore and state waters. <https://pubs.usgs.gov/publication/70176229>
- Dolton, G. L., Carlson, K. H., Charpentier, R. R., and others (1981). Estimates of Undiscovered Recoverable Conventional Resources of Oil and Gas in the United States. U.S. Geological Survey, Geological Circular 860, 87 pp.
- Ewing, T. E. (2009). The ups and downs of the Sabine Uplift and the northern Gulf of Mexico Basin: Jurassic basement blocks, Cretaceous thermal uplifts, and Cenozoic flexure. *GCAGS Transactions*, Vol. 59, p. 253-269.
- Foote, R. Q., Massingill, L. M., and Wells, R. H. (1988). Petroleum geology and the distribution of conventional crude oil, natural gas liquids, East Texas basin. U.S. Geological Survey, DOI Report 88-450K, 118 pp.
- Galloway, W.E. (2008). Sedimentary Basins of the World: Chapter 15, Depositional Evolution of the Gulf of Mexico Sedimentary Basin, Vol. 5: 505-549. [http://dx.doi.org/10.1016/S1874-5997\(08\)00015-4](http://dx.doi.org/10.1016/S1874-5997(08)00015-4)

- Hentz, T. F., and Ruppel, S. C. (2011). Regional Stratigraphic and Rock Characteristics of Eagle Ford Shale in Its Play Area: Maverick Basin to East Texas Basin. *AAPG Search and Discovery Article #10325*
- Hentz, T. F., Ambrose, W. A., and Smith, D. C. (2014). Eaglebine play of the southwestern East Texas basin: Stratigraphic and depositional framework of the Upper Cretaceous (Cenomanian-Turonian) Woodbine and Eagle Ford Groups. *AAPG Bulletin, Vol. 98, No. 12*, p. 2551-2580.
- Holtz, M. H., Nance, P. K., and Finley, R. J. (1999). Reduction of Greenhouse Gas Emissions through Underground CO₂ Sequestration in Texas Oil and Gas Reservoirs. The University of Texas at Austin, Bureau of Economic Geology, Final Report, 82 pp.
- Hovorka, S. D. (1999). Optimal Geological Environments for Carbon Dioxide Disposal in Saline Aquifers in the United States. Bureau of Economic Geology, The University of Texas at Austin.
- Jackson, M. P. A. (1982). Fault Tectonics of the East Texas Basin. Bureau of Economic Geology, The University of Texas at Austin, Geological Circular 82-4, 31 pp.
- Jackson, M. P. A., and Seni, S. J. (1984). Atlas of salt domes in the East Texas basin. Bureau of Economic Geology, The University of Texas at Austin Report of Investigation No. 140, 102 pp.
- Loucks, R. G., Reed, R. M., Ambrose, W. A. (2015). Analysis of Pore Networks and Reservoir Quality of the Upper Cretaceous Woodbine Sandstone in the High-Recovery-Efficiency, Giant East Texas Field. *GCAGS Journal, Vol. 4*, p. 88-108.
- Meyer, M. J., Donovan, A. D., and Pope, M. C. (2021). Depositional environment and source rock quality of the Woodbine and Eagle Ford Groups, southern East Texas (Brazos) Basin: An integrated geochemical, sequence stratigraphic, and petrographic approach. *AAPG Bulletin, Vol. 105, No. 4*, p. 809-843.
- Patterson, S., and Denne, R. (2019). The Maness Shale: A Comparison of the Geomechanical and Mineralogic Properties within the Lower Eagle Ford Near the San Marcos Arch. *AAPG Datapages, Search and Discovery Article No. 11240*.
- Przywara, M., Howard, A., Hernandez, R., and Brooks, D. (2011). Unconventional Reservoir Evaluation: Focus on the Eagle Ford. *Gulf Coast Association of Geological Societies Transactions, Vol. 61*, p. 625-629.
- Ramiro-Ramirez, S., Sonnenberg, S. A., and Santi, P. (2016). Petrographic and Petrophysical Characterization of the Eagle Ford Shale in La Salle and Gonzales Counties, Gulf Coast Region, Texas. *Colorado School of Mines, 2016 Thesis Paper*.
- Swanson, S.M., Enomoto, C.B., Dennen, K.O. et al. (2016). Geologic assessment of undiscovered oil and gas resources—Lower Cretaceous Albian to Upper Cretaceous Cenomanian carbonate

rocks of the Fredericksburg and Washita Groups, United States Gulf of Mexico Coastal Plain and State Waters: U.S. Geological Survey Open-File Report 2016–1199, 69 pp. <https://doi.org/10.3133/ofr20161199>

Wescott, W. A., and Hood, W. C. (1994). Hydrocarbon generation and migration routes in the East Texas Basin. *AAPG Bulletin*, Vol. 78, p. 287-307.

Yurewicz, D.A., Marler, T.B., Meyerholtz, K.A., and Siroky, F.X. (1993). Early Cretaceous Carbonate Platform, North Rim of the Gulf of Mexico, Mississippi and Louisiana, Chapter 8 of Cretaceous Carbonate Platforms. *AAPG Memoir* 56, J. A. Toni Simo, Robert W. Scott, Jean-Pierre Masse, 81-96. <https://doi.org/10.1306/M56578C8>